

F023 ALPHA ACER TENDL-2024 LIBRARY; T=0.K
Principal cross sections

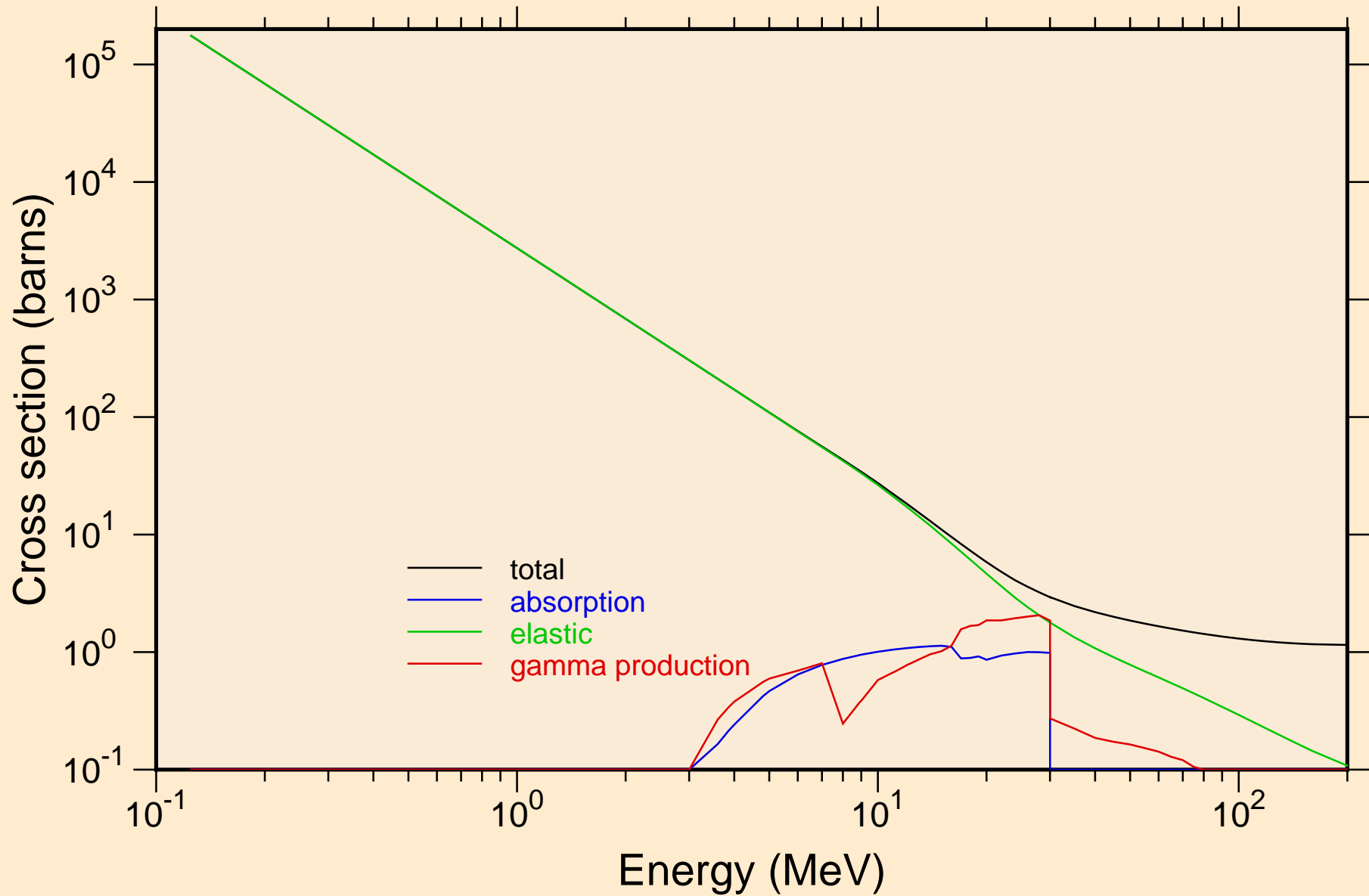

F023 ALPHA ACER TENDL-2024 LIBRARY; T=0.K

Heating

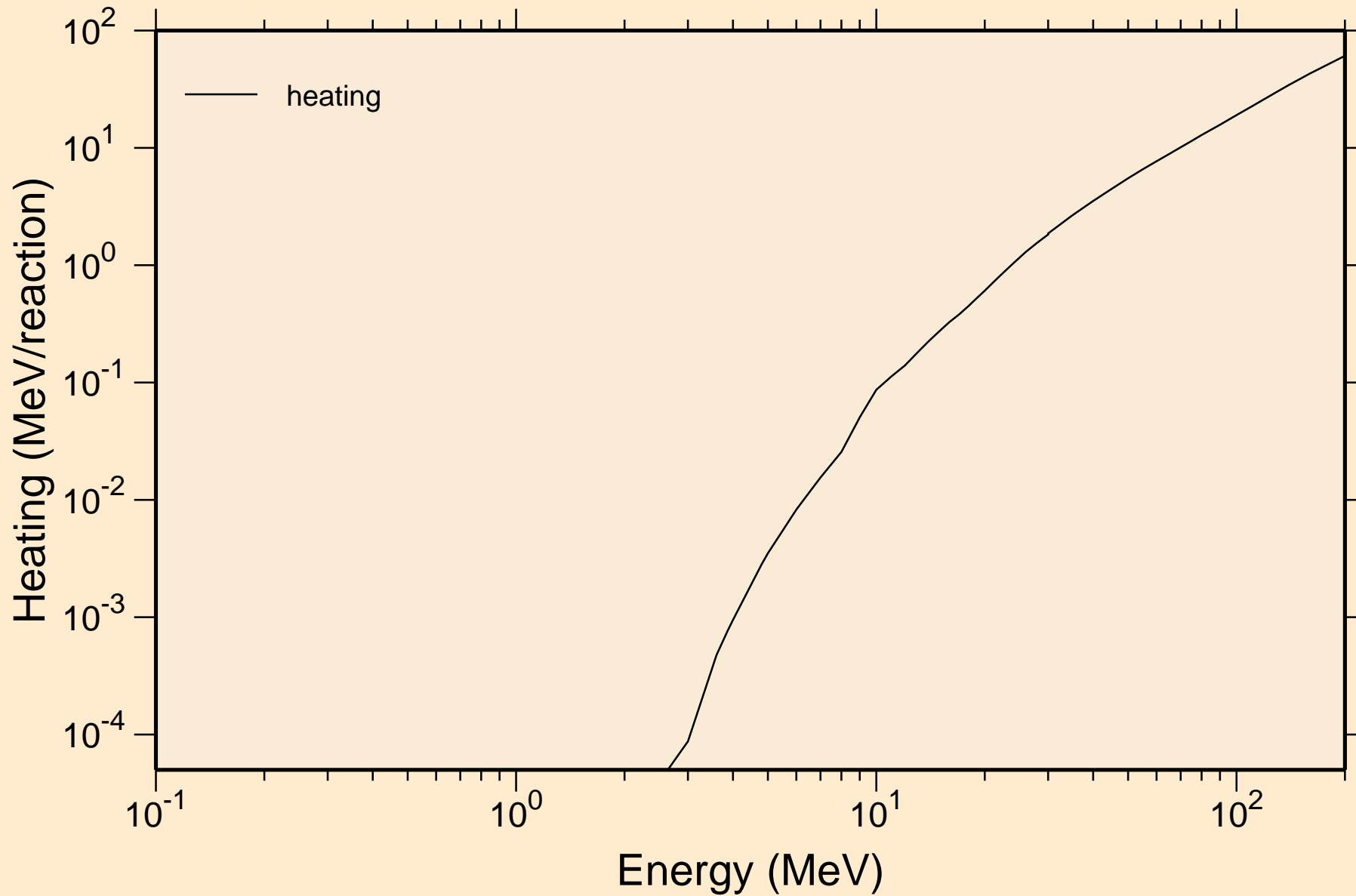

F023 ALPHA ACER TENDL-2024 LIBRARY; T=0.K

Principal cross sections

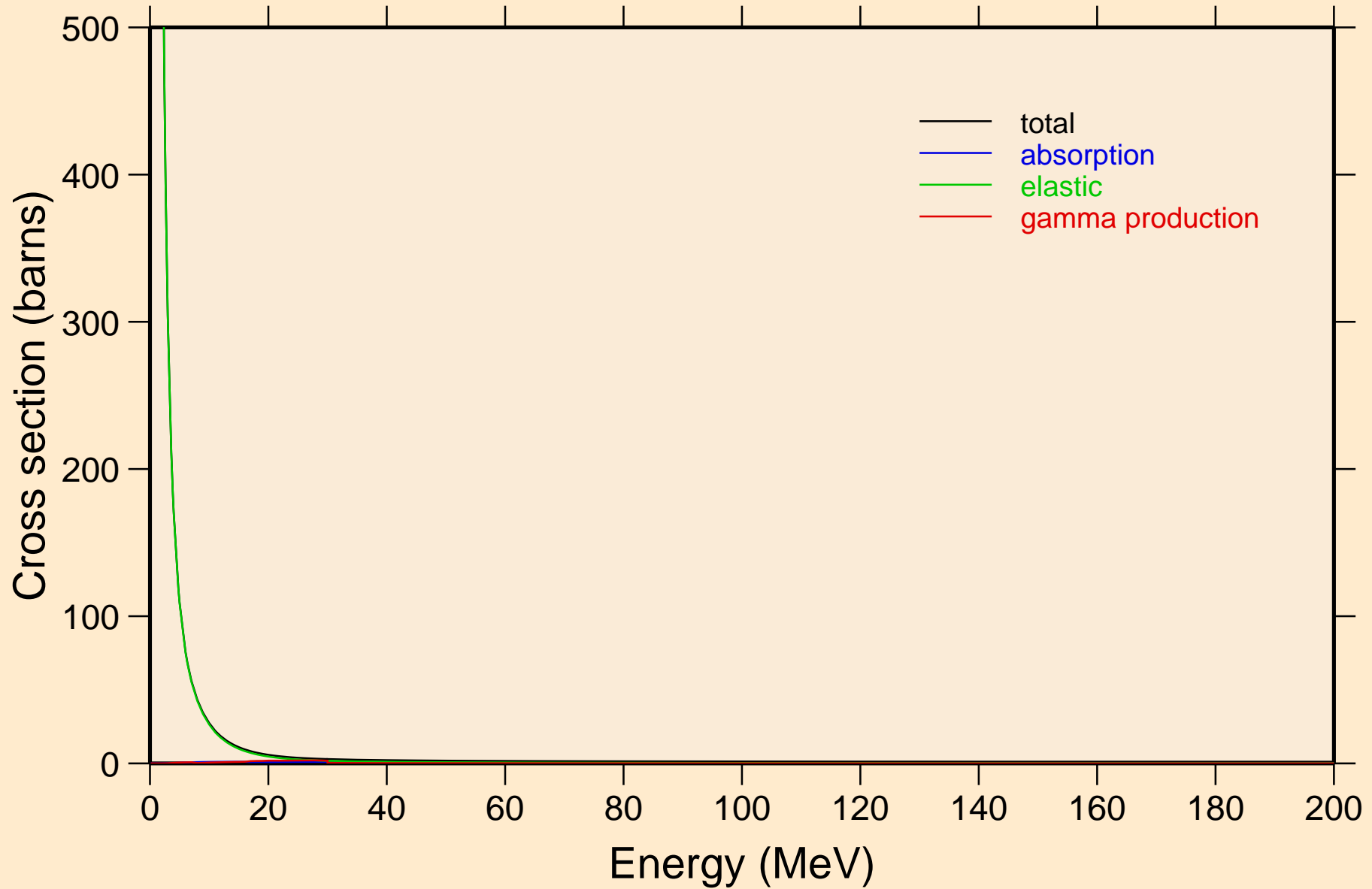

F023 ALPHA ACER TENDL-2024 LIBRARY; T=0.K

Heating

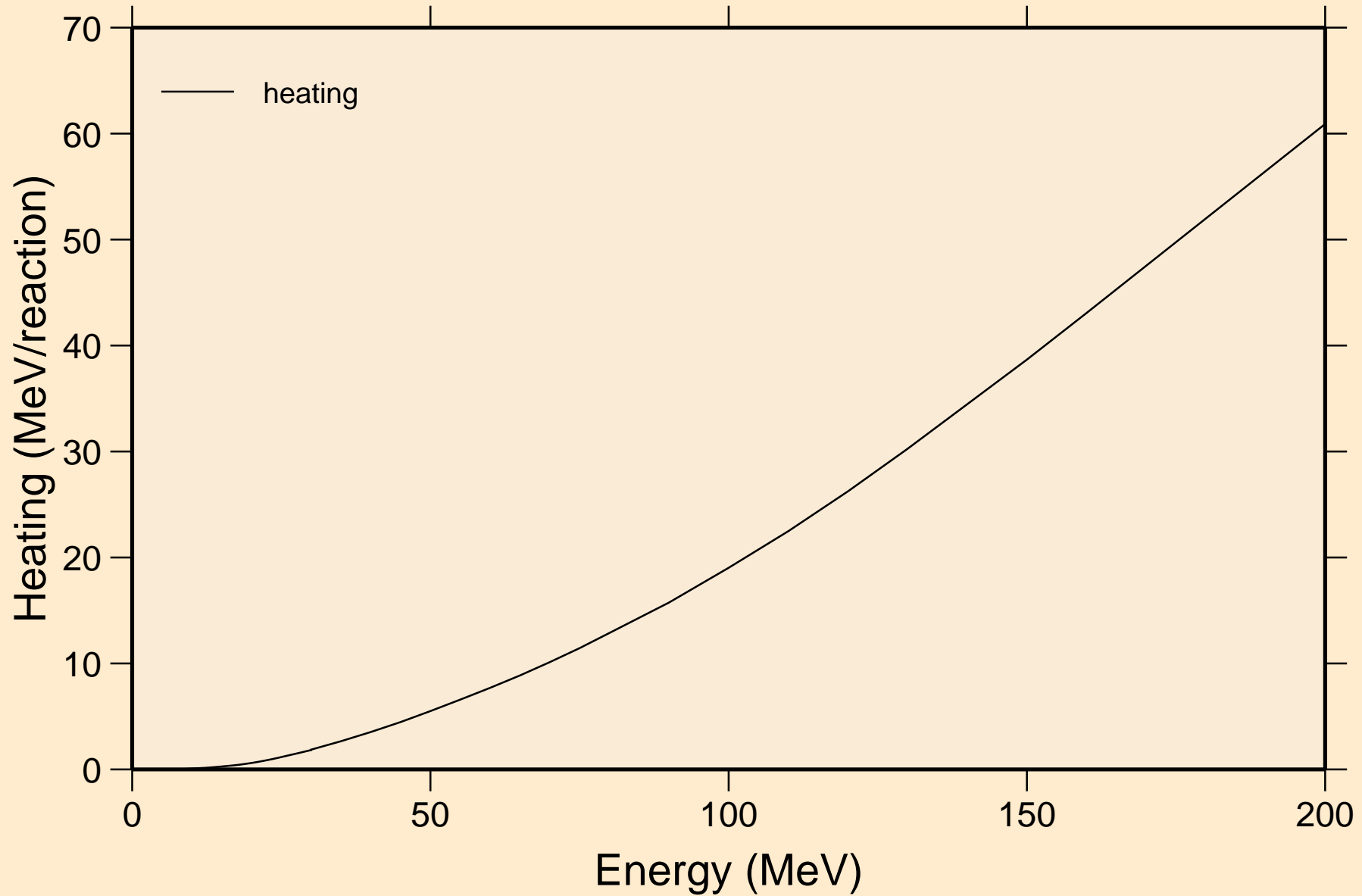

F023 ALPHA ACER TENDL-2024 LIBRARY; T=0.K
Threshold reactions

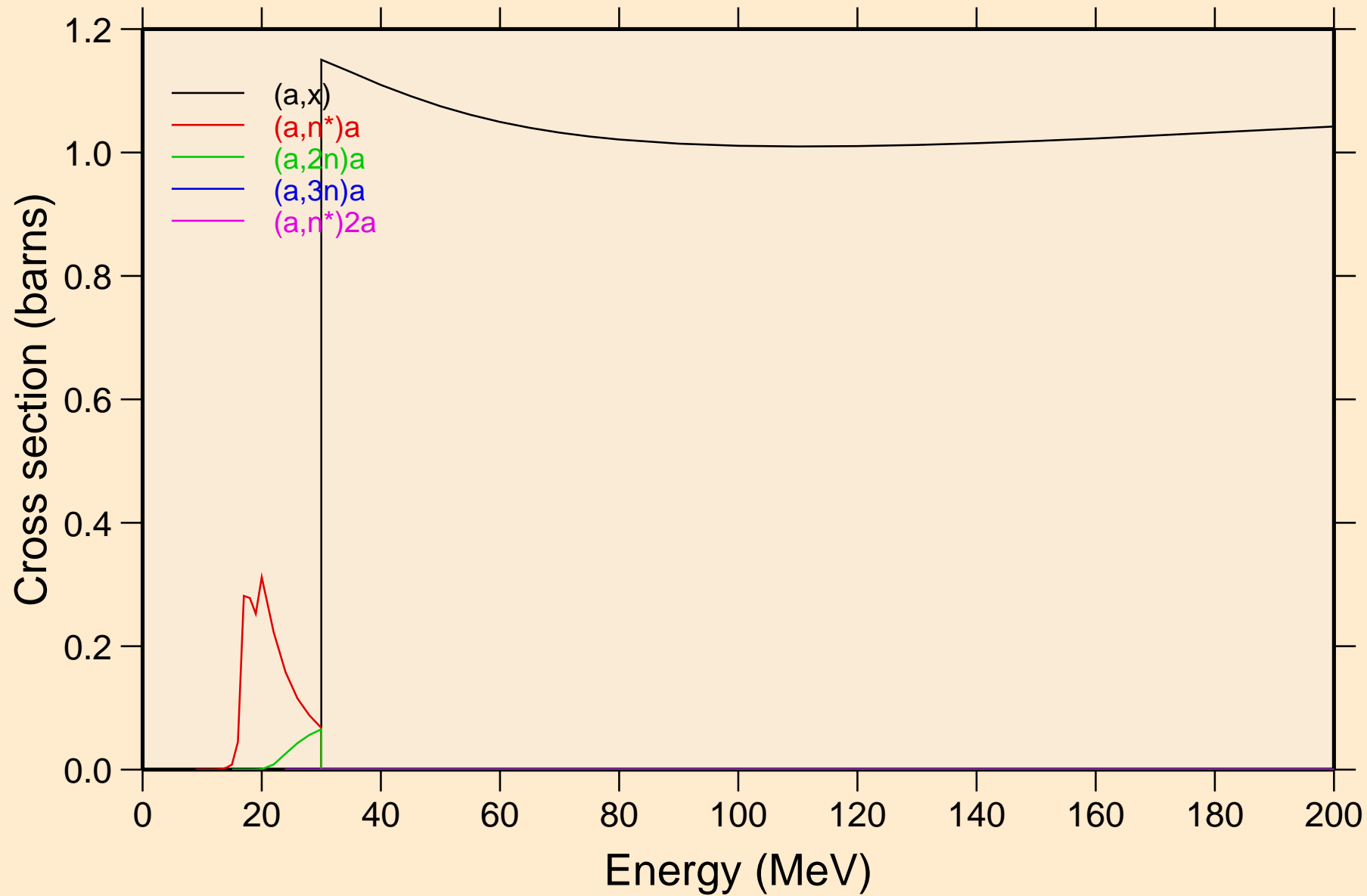

F023 ALPHA ACER TENDL-2024 LIBRARY; T=0.K
Threshold reactions

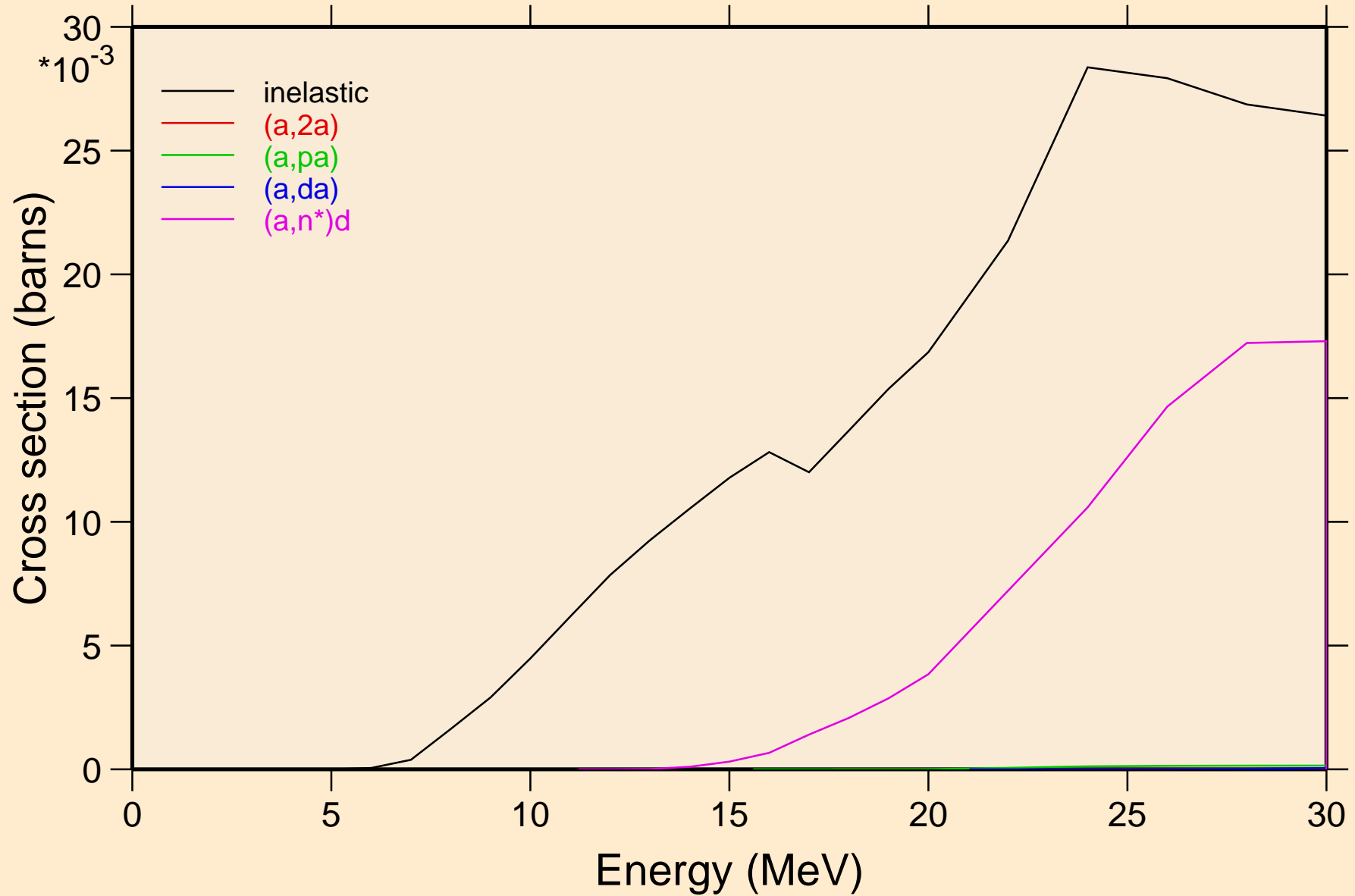

F023 ALPHA ACER TENDL-2024 LIBRARY; T=0.K

Threshold reactions

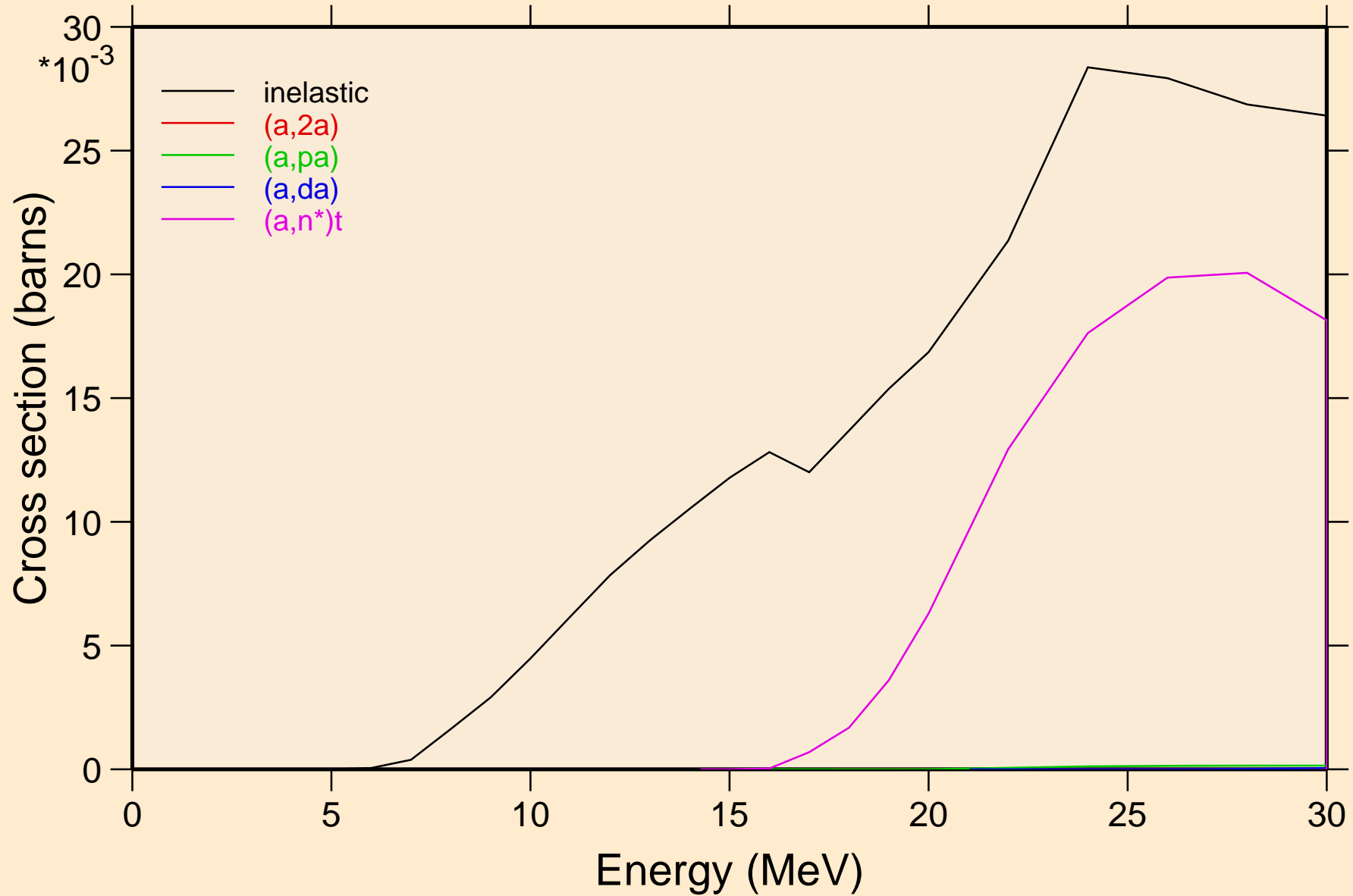

F023 ALPHA ACER TENDL-2024 LIBRARY; T=0.K
Threshold reactions

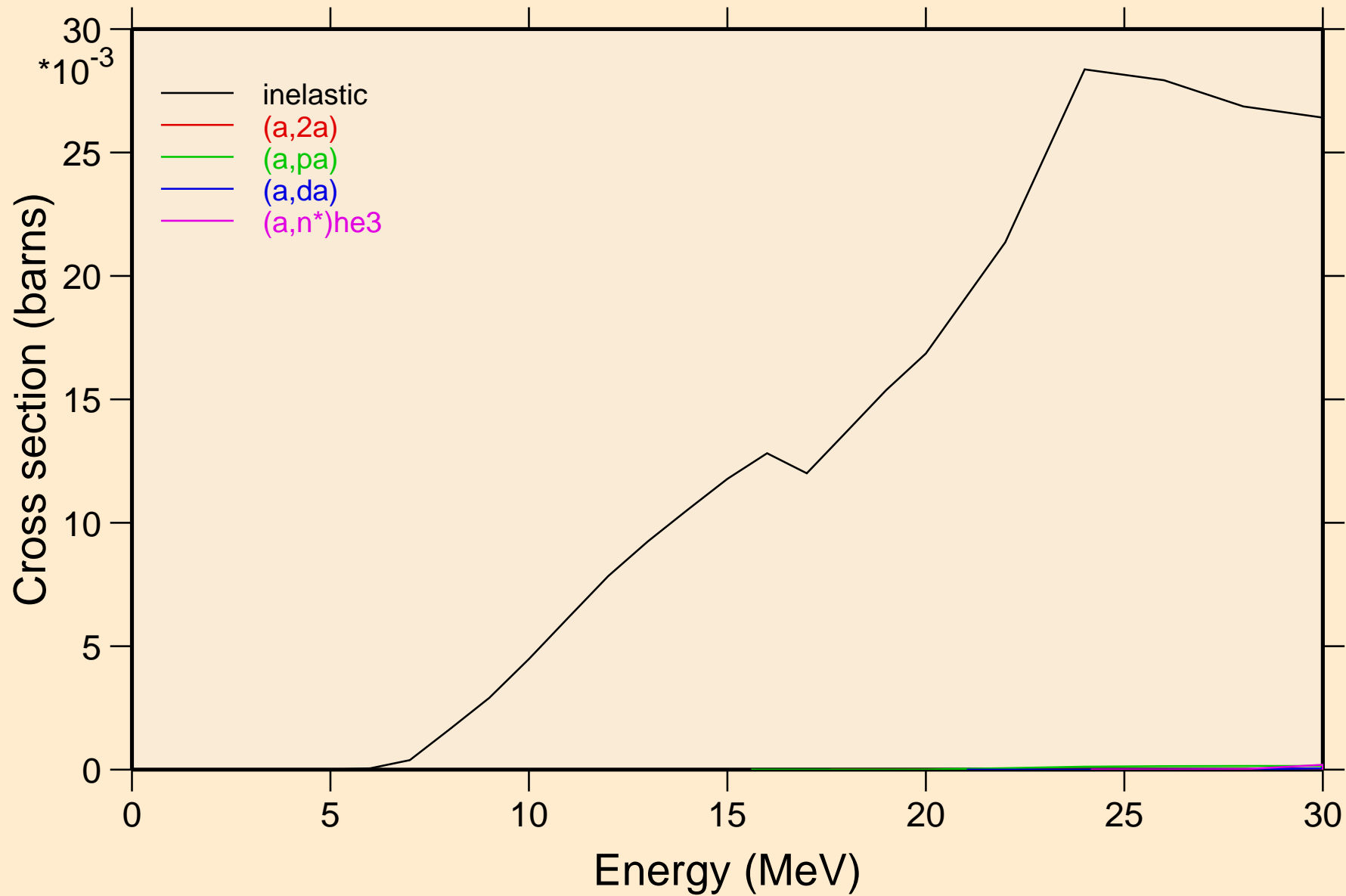

F023 ALPHA ACER TENDL-2024 LIBRARY; T=0.K
Threshold reactions

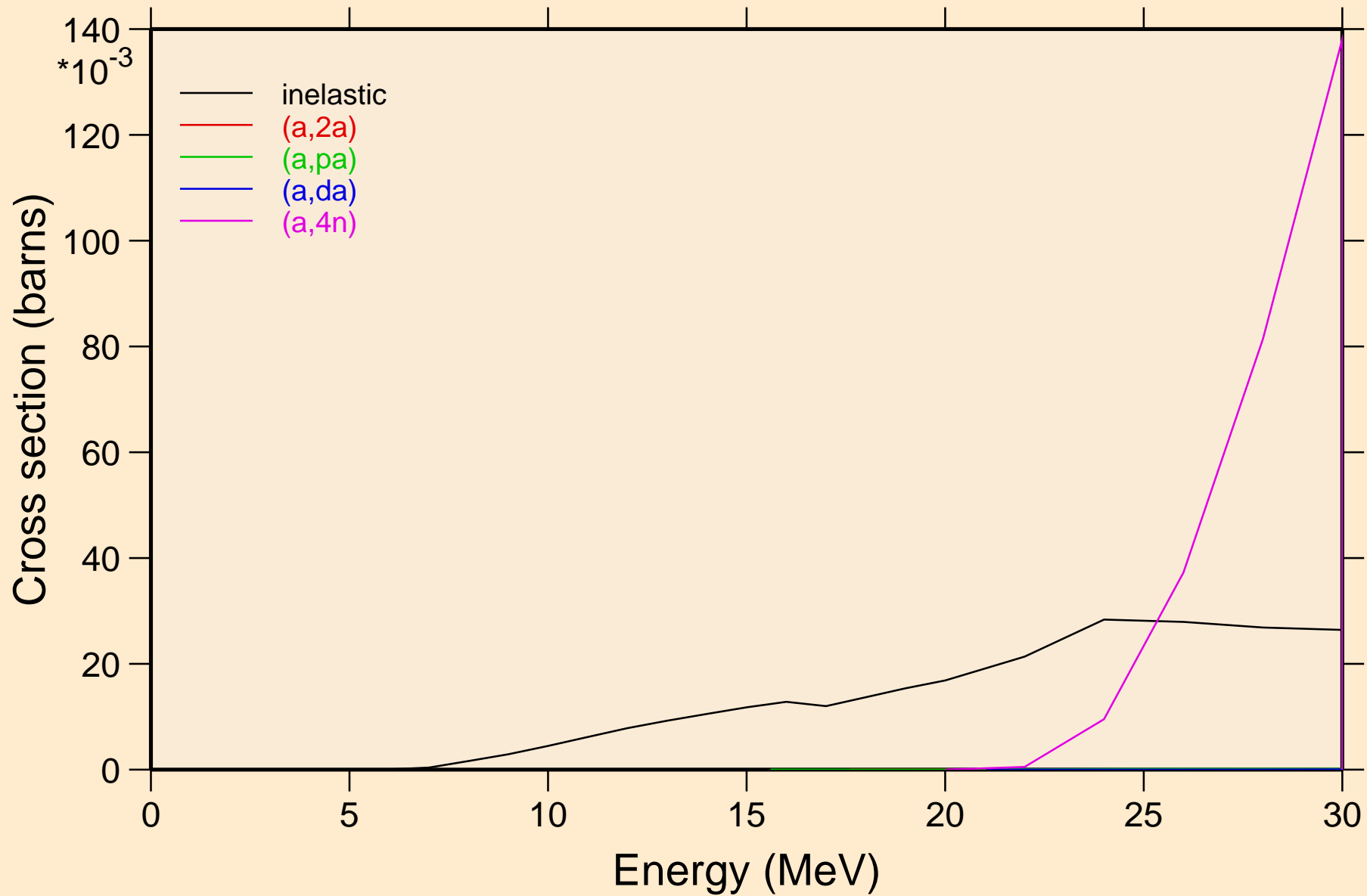

F023 ALPHA ACER TENDL-2024 LIBRARY; T=0.K
Threshold reactions

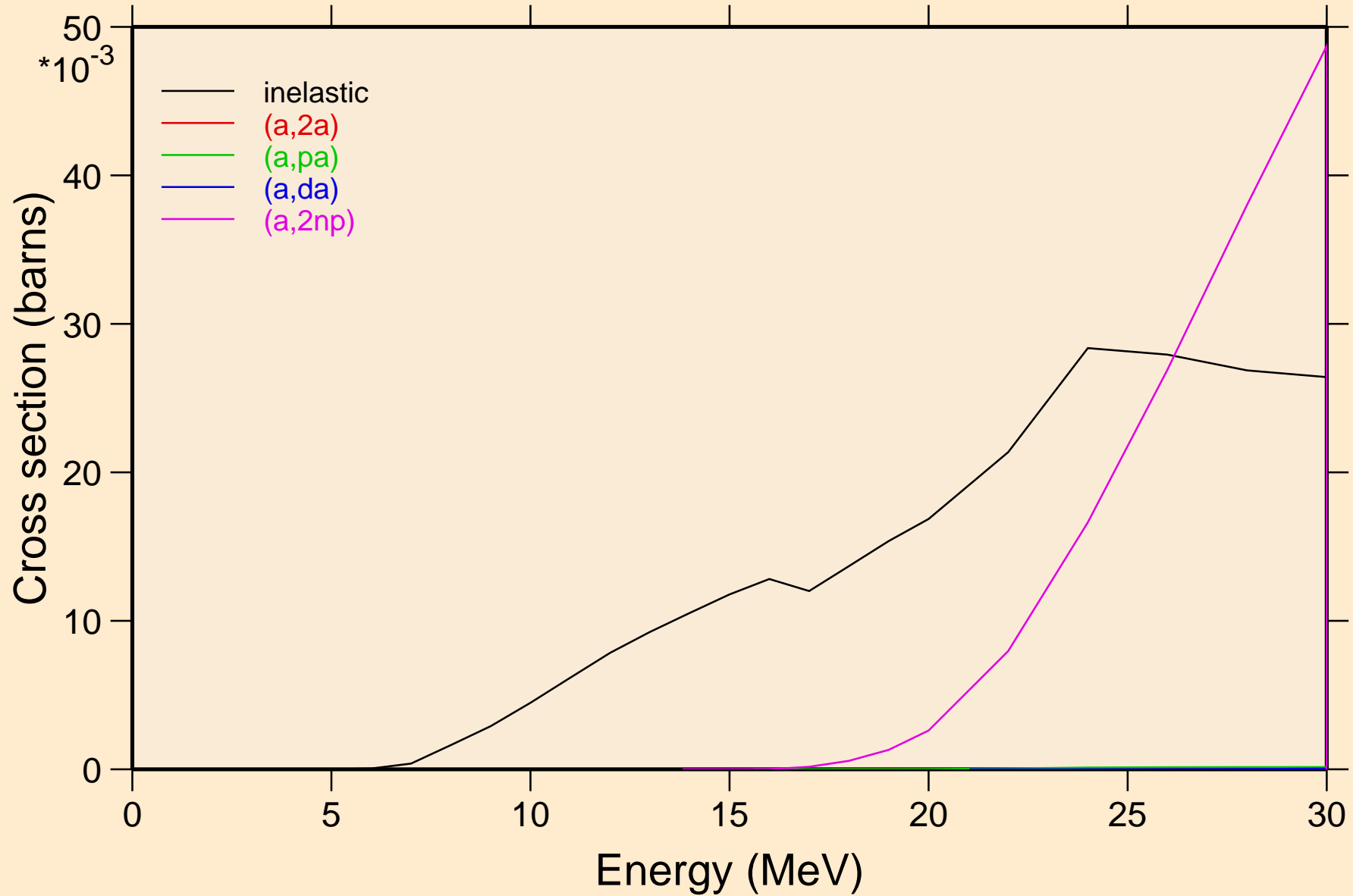

F023 ALPHA ACER TENDL-2024 LIBRARY; T=0.K
Threshold reactions

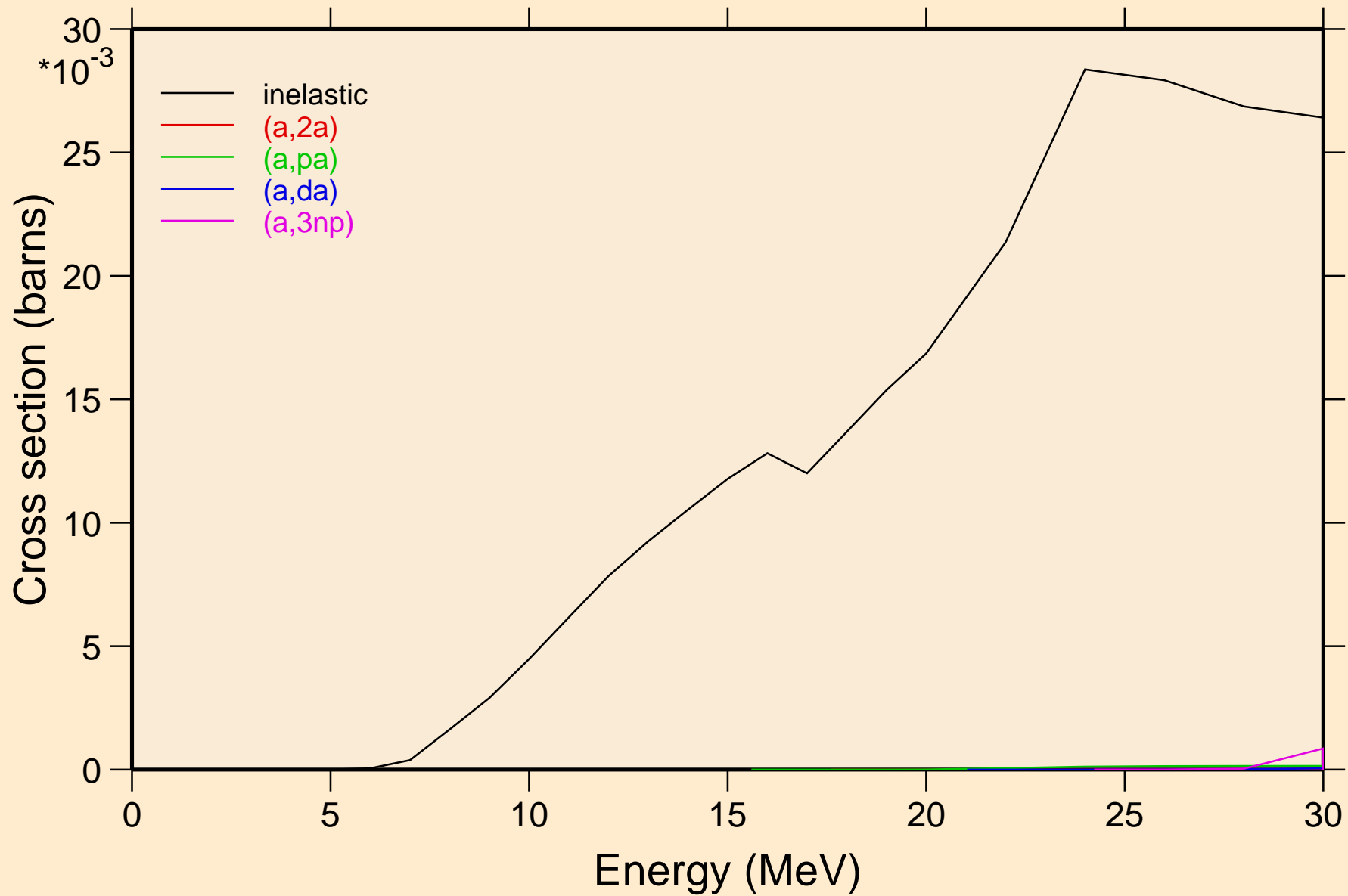

F023 ALPHA ACER TENDL-2024 LIBRARY; T=0.K
Threshold reactions

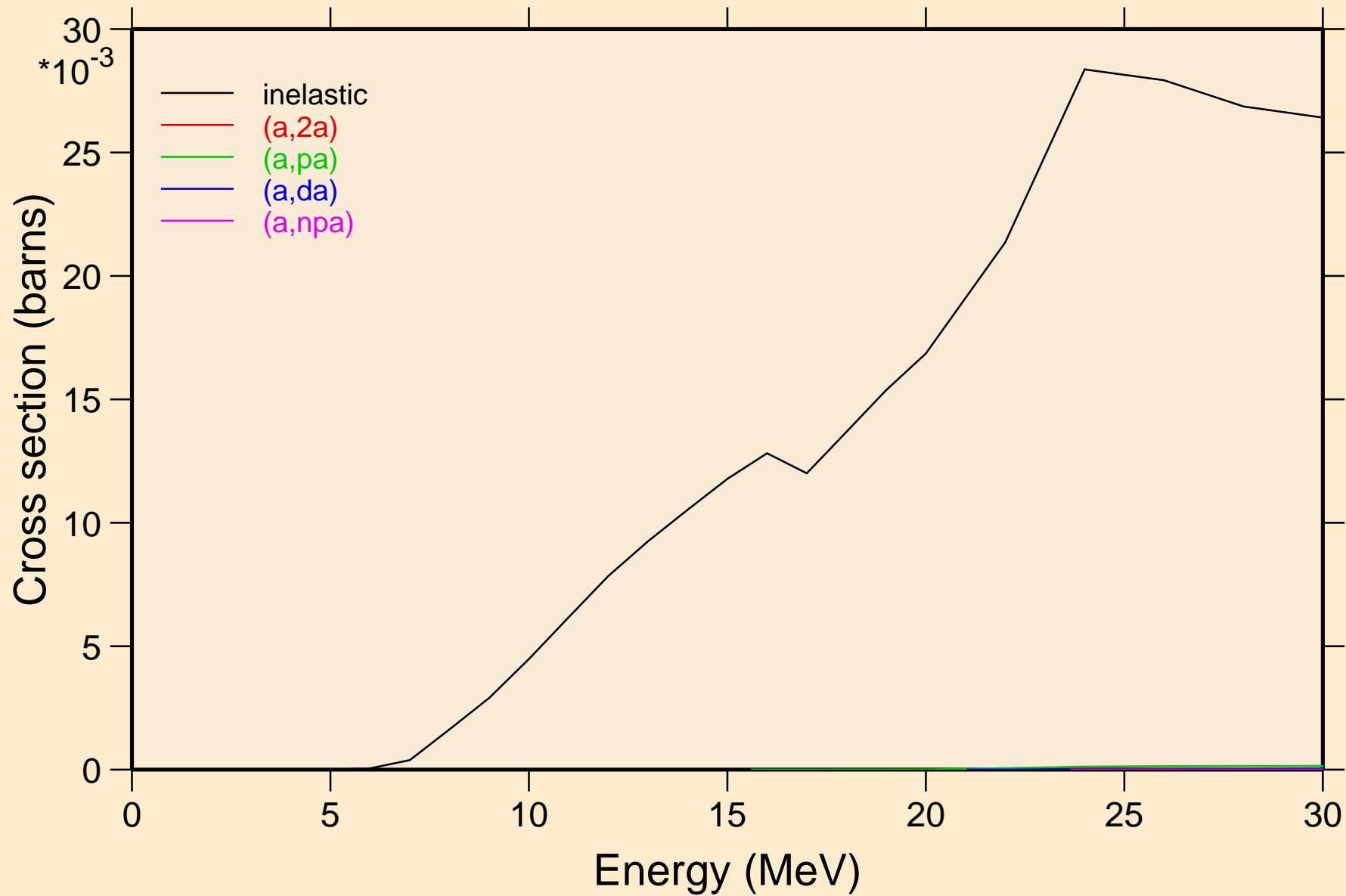

F023 ALPHA ACER TENDL-2024 LIBRARY; T=0.K
Threshold reactions

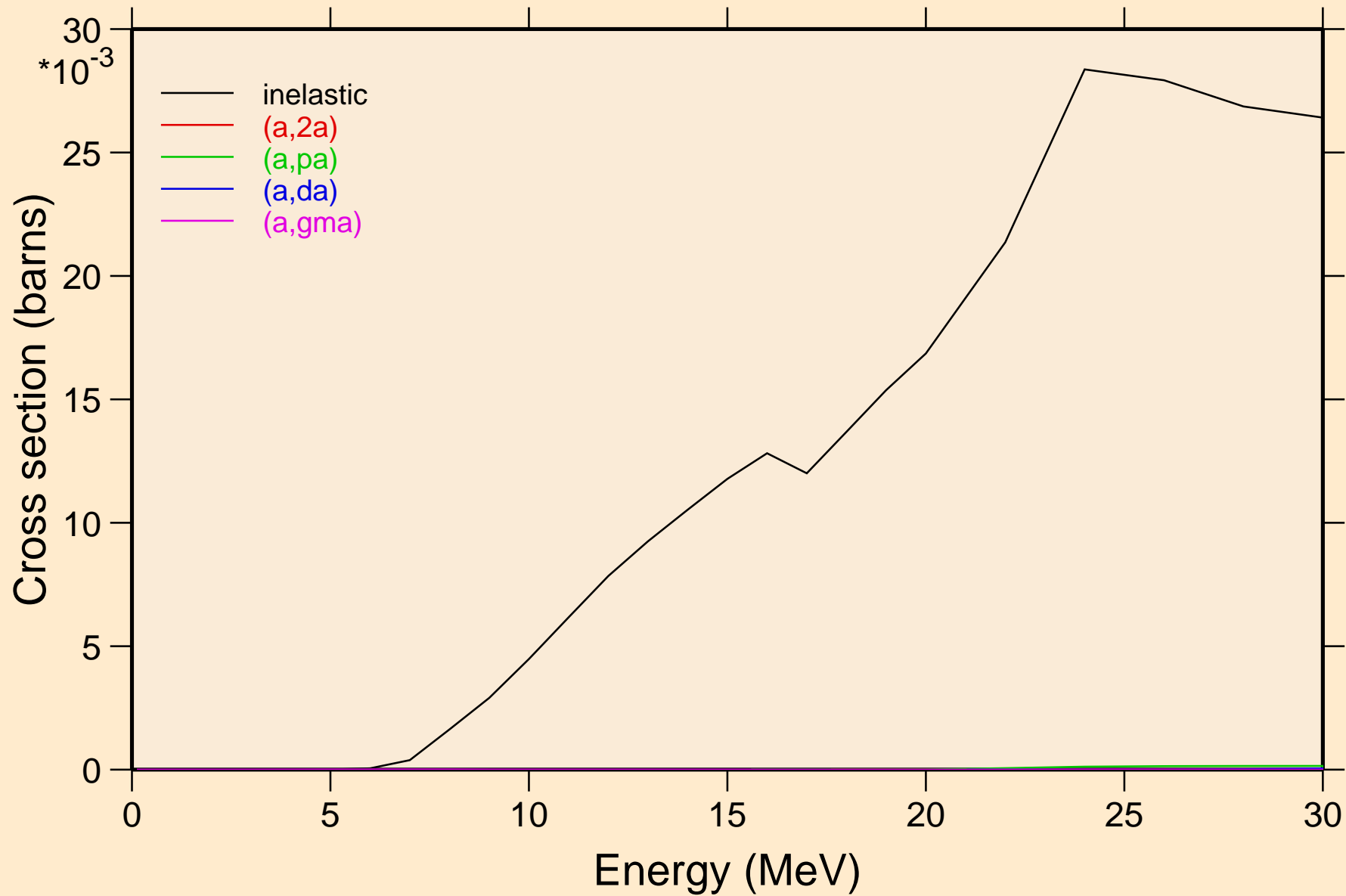

F023 ALPHA ACER TENDL-2024 LIBRARY; T=0.K
Threshold reactions

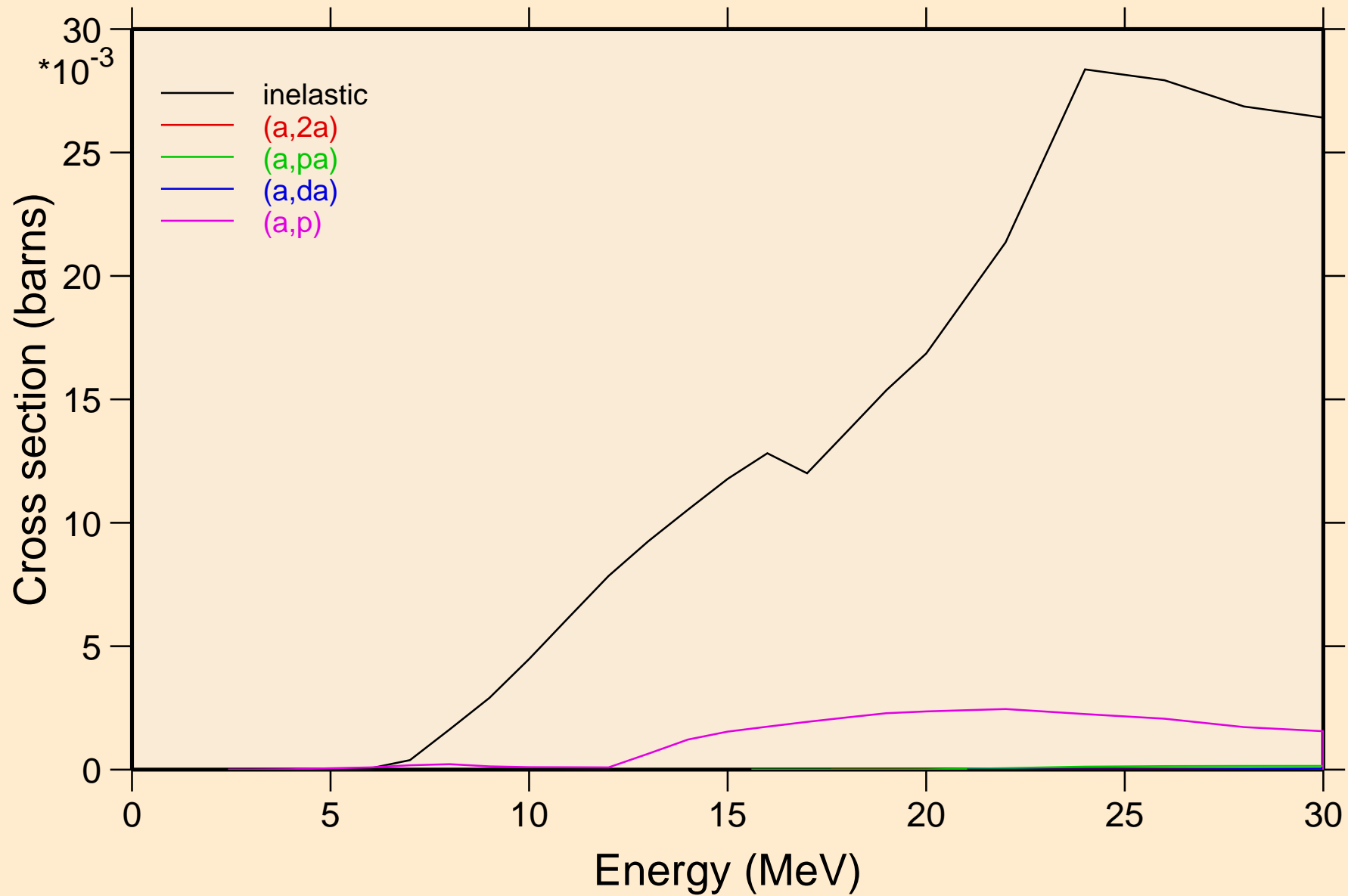

F023 ALPHA ACER TENDL-2024 LIBRARY; T=0.K
Threshold reactions

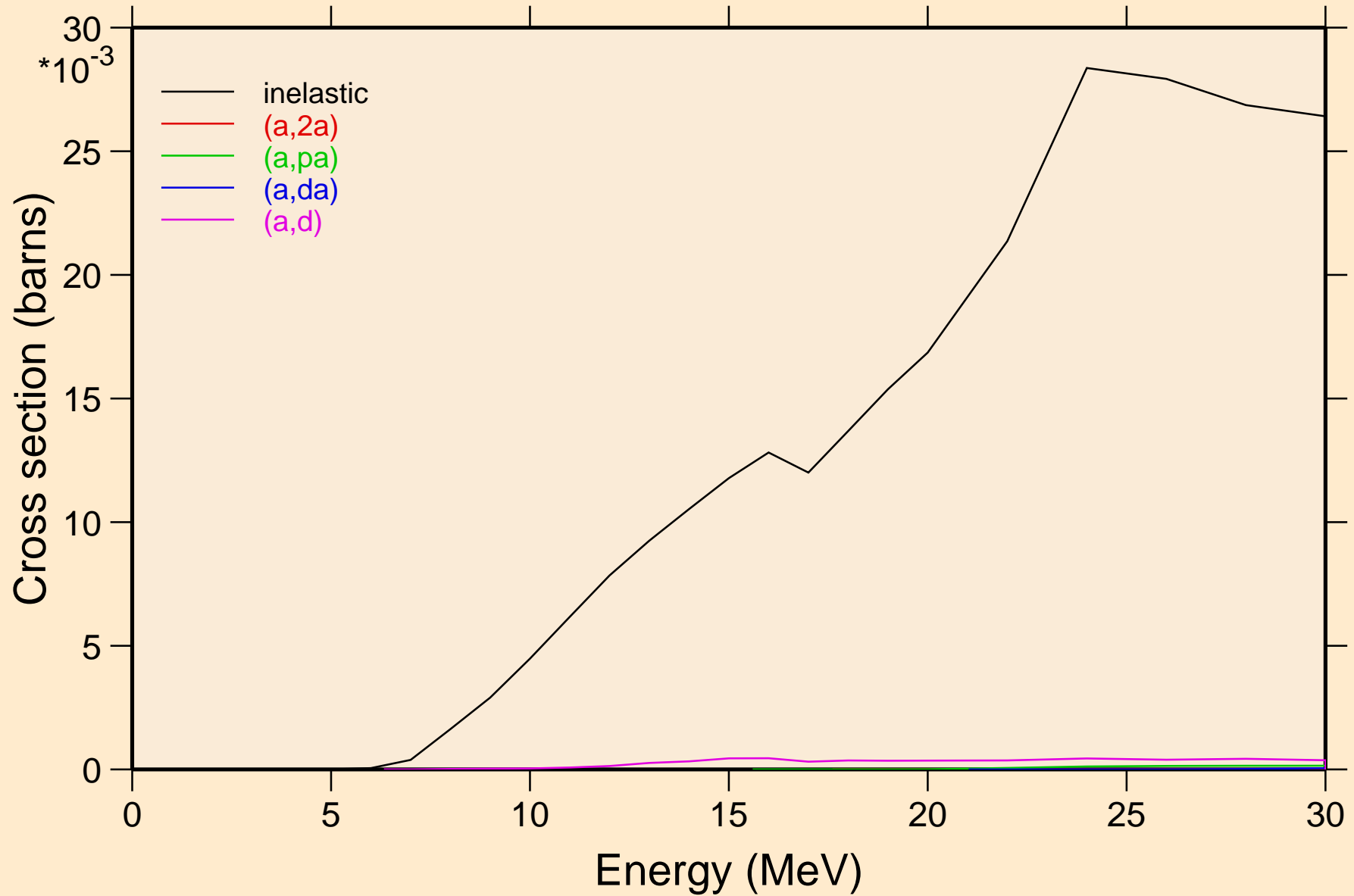

F023 ALPHA ACER TENDL-2024 LIBRARY; T=0.K

Threshold reactions

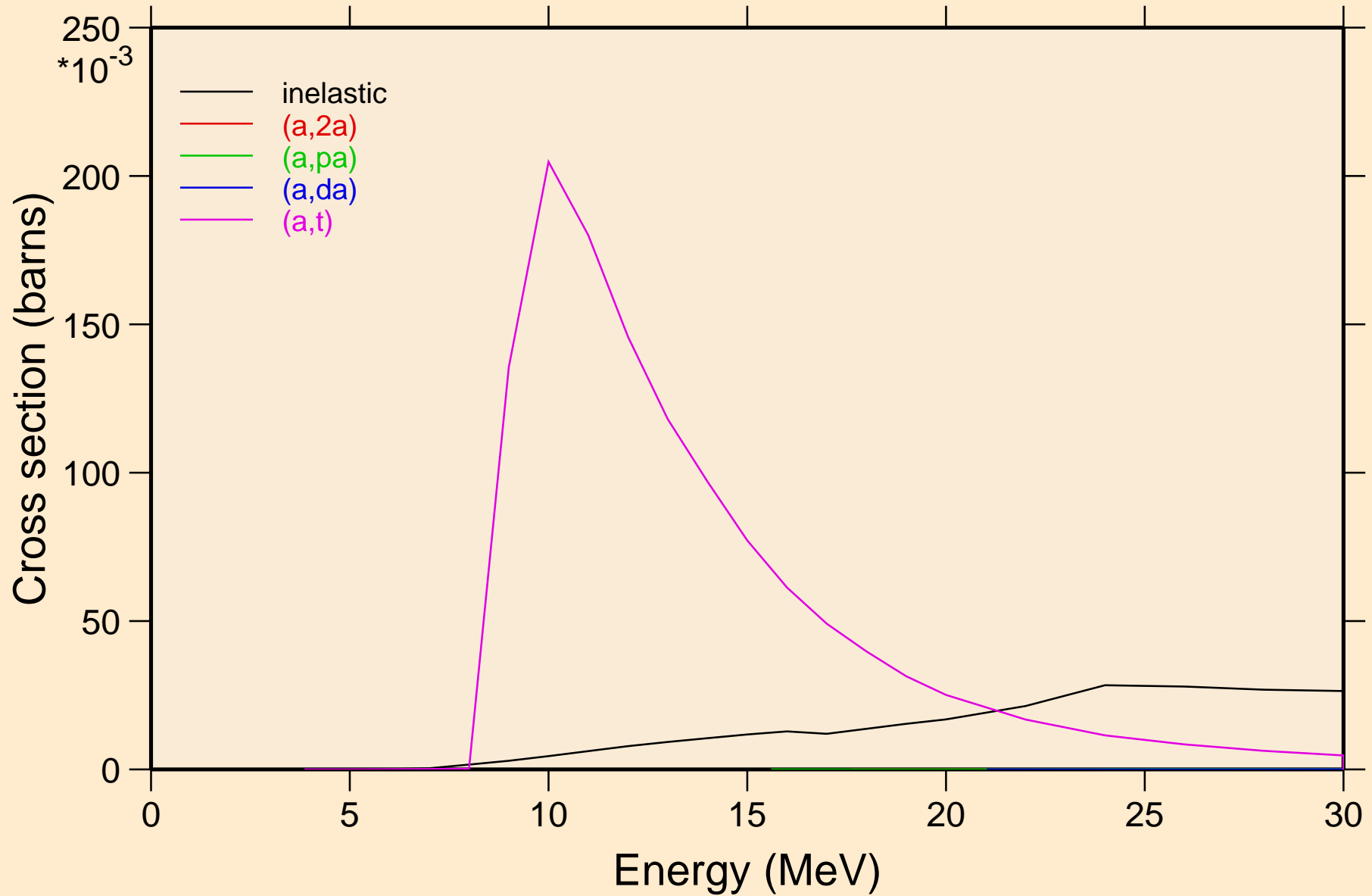

F023 ALPHA ACER TENDL-2024 LIBRARY; T=0.K
Threshold reactions

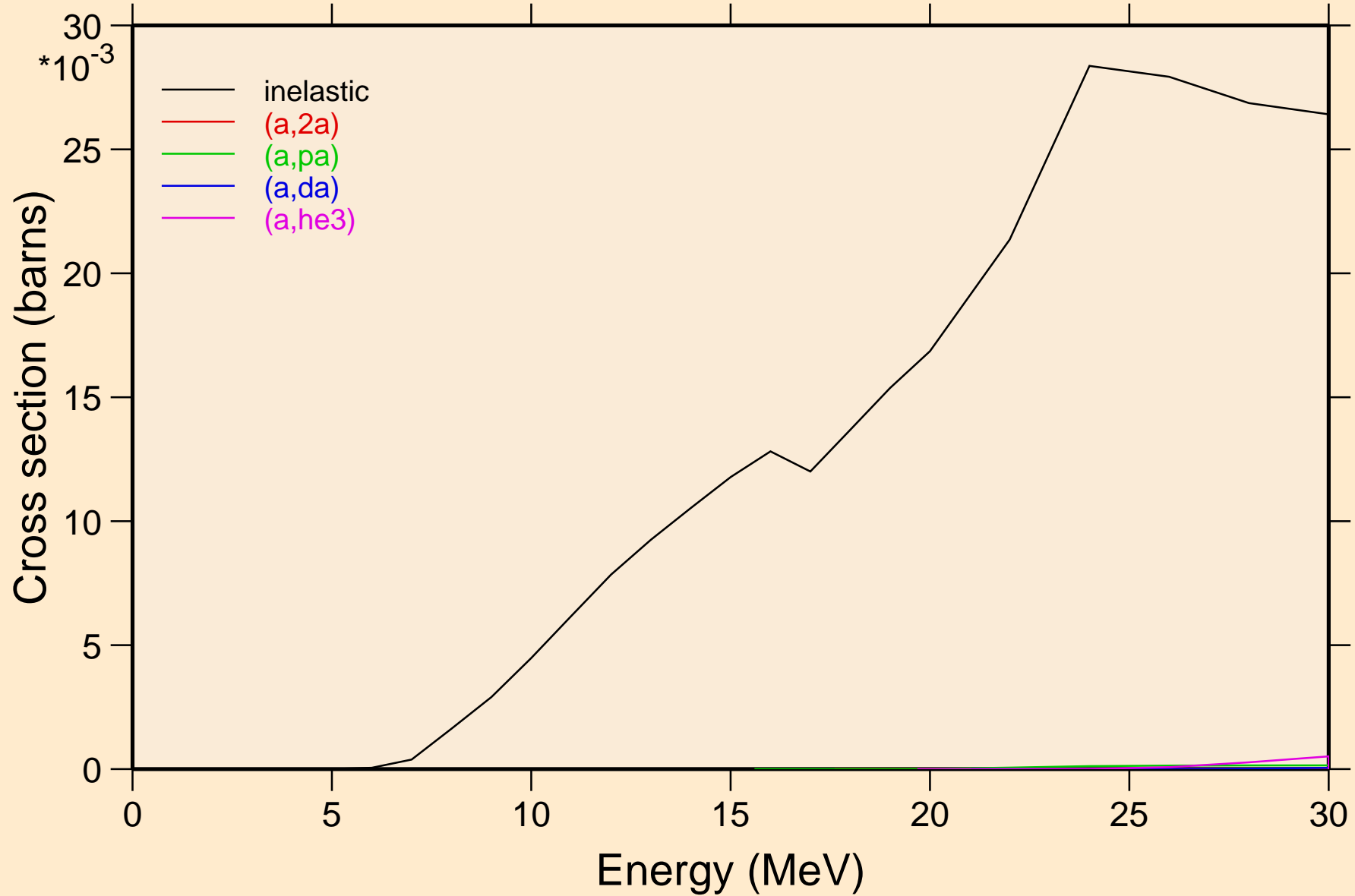

F023 ALPHA ACER TENDL-2024 LIBRARY; T=0.K
Threshold reactions

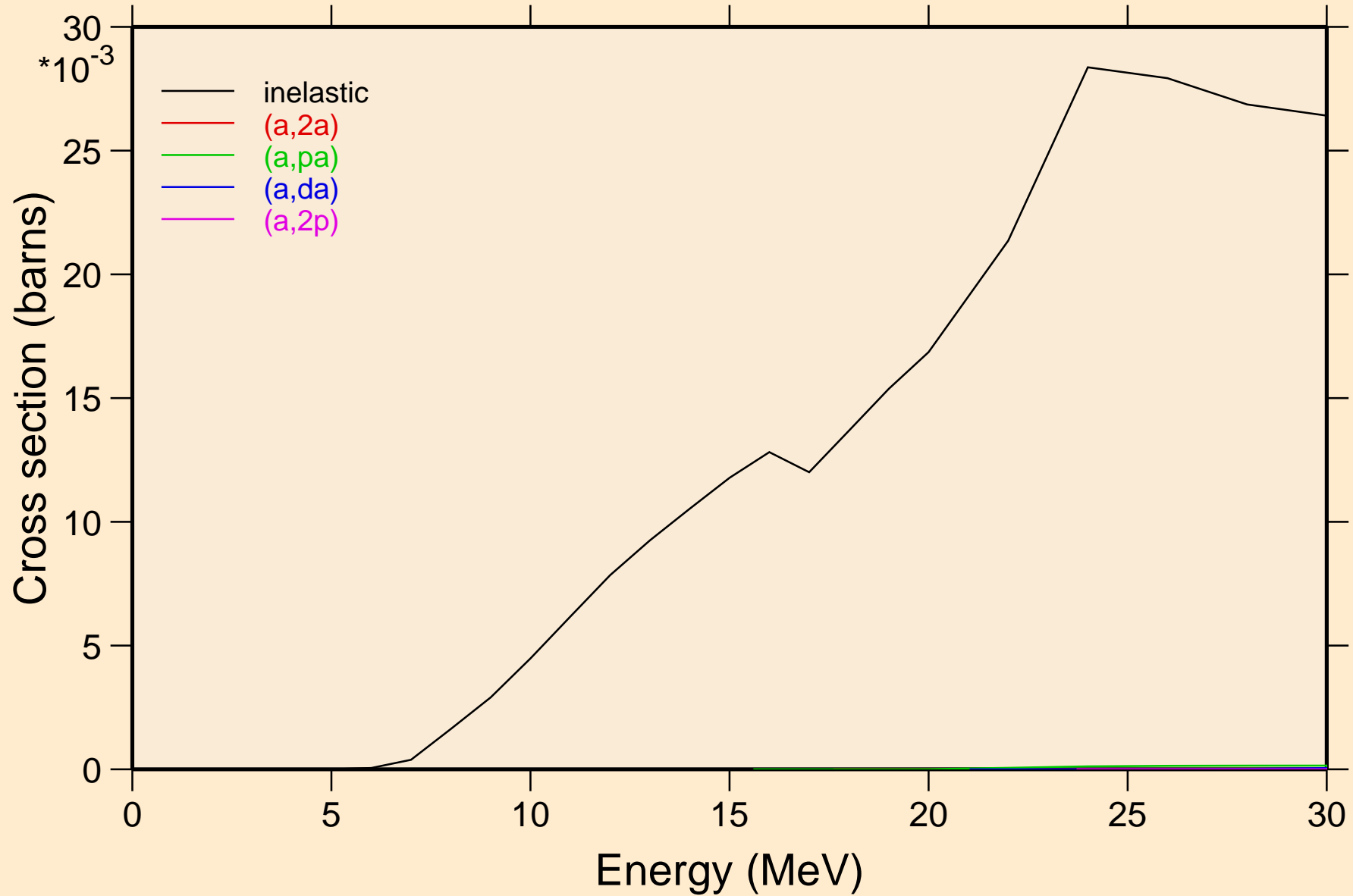

F023 ALPHA ACER TENDL-2024 LIBRARY; T=0.K
Threshold reactions

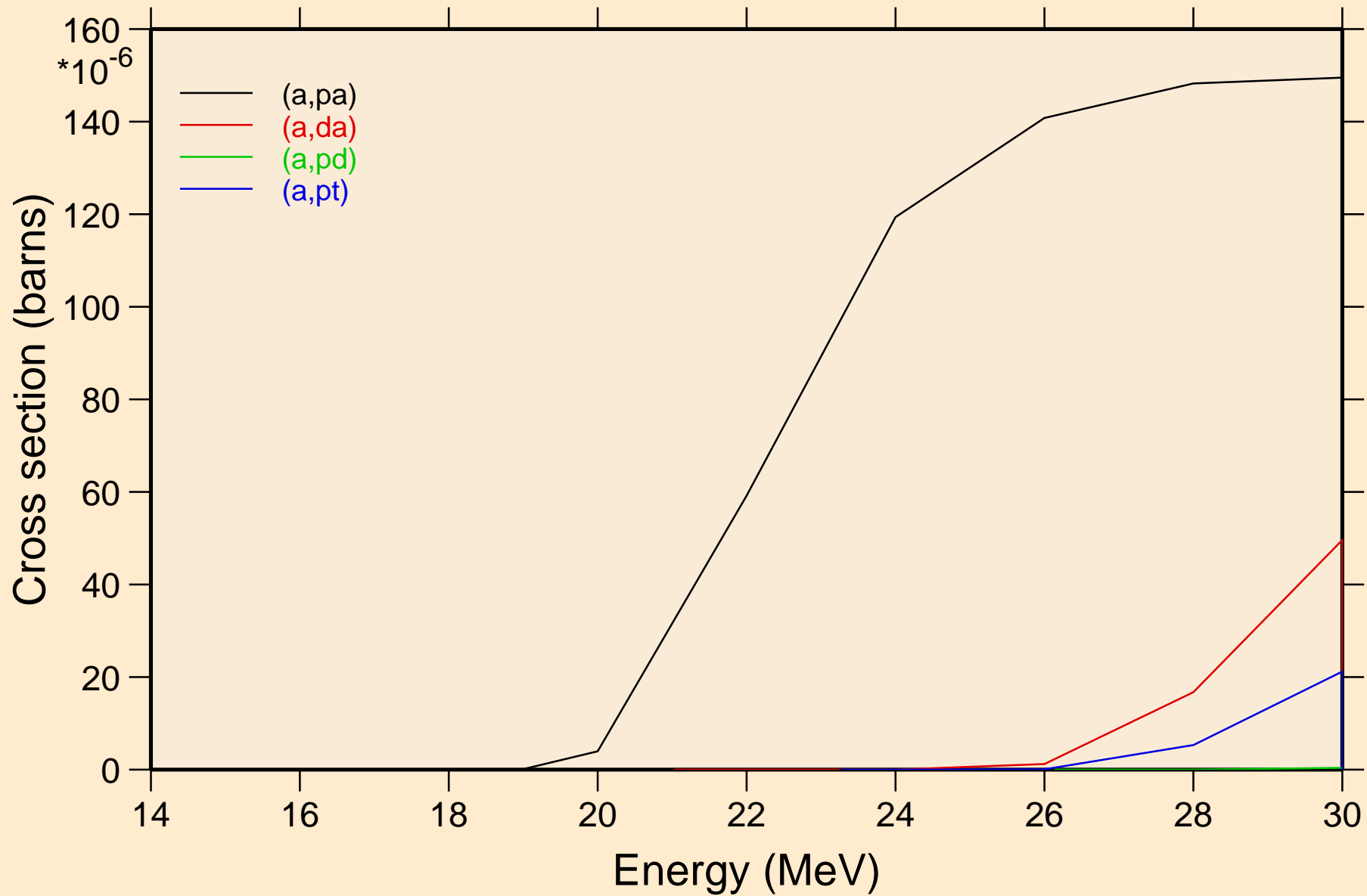

F023 ALPHA ACER TENDL-2024 LIBRARY; T=0.K
Threshold reactions

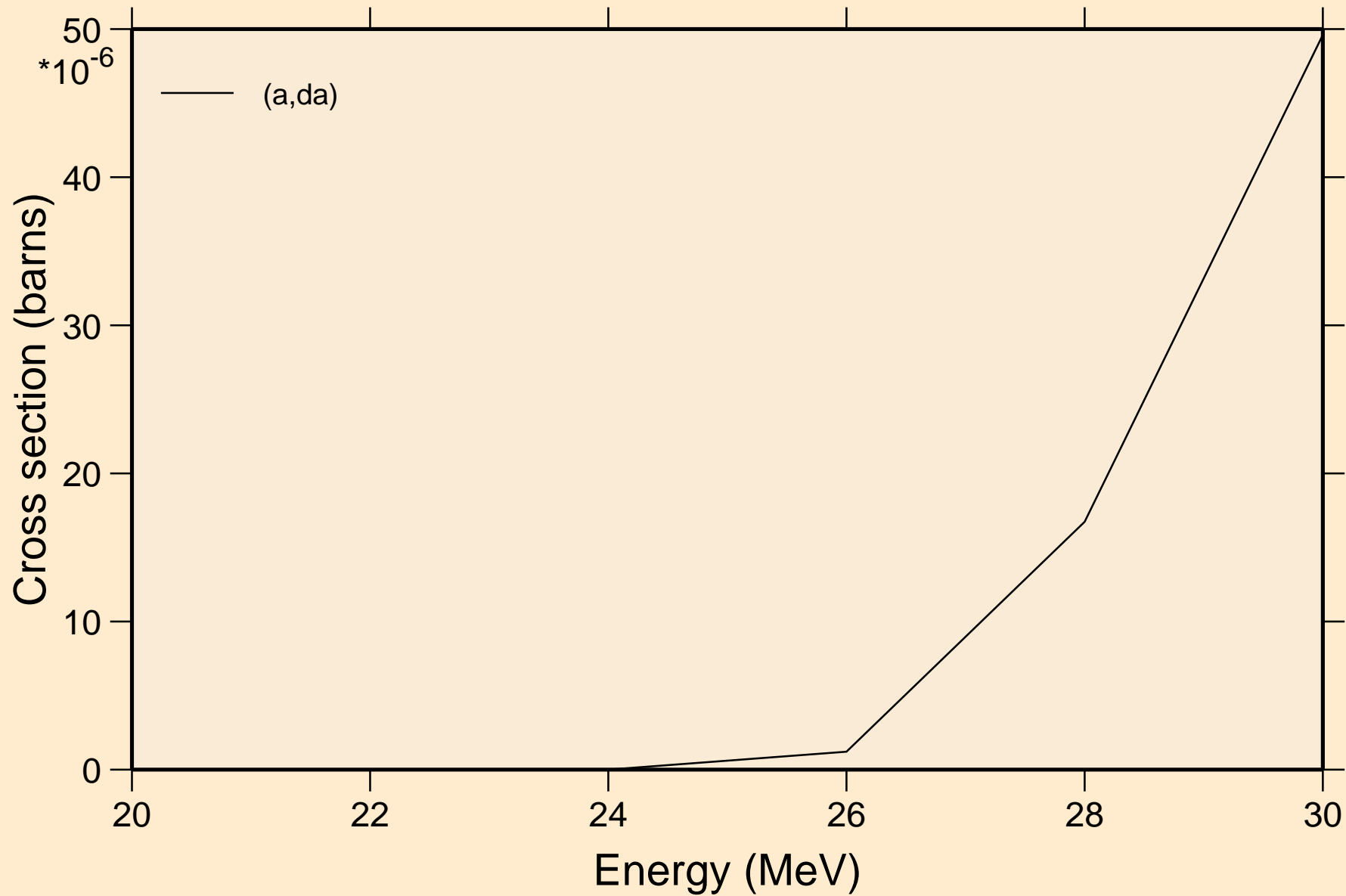

F023 ALPHA ACER TENDL-2024 LIBRARY: T=0.K
angular distribution for elastic

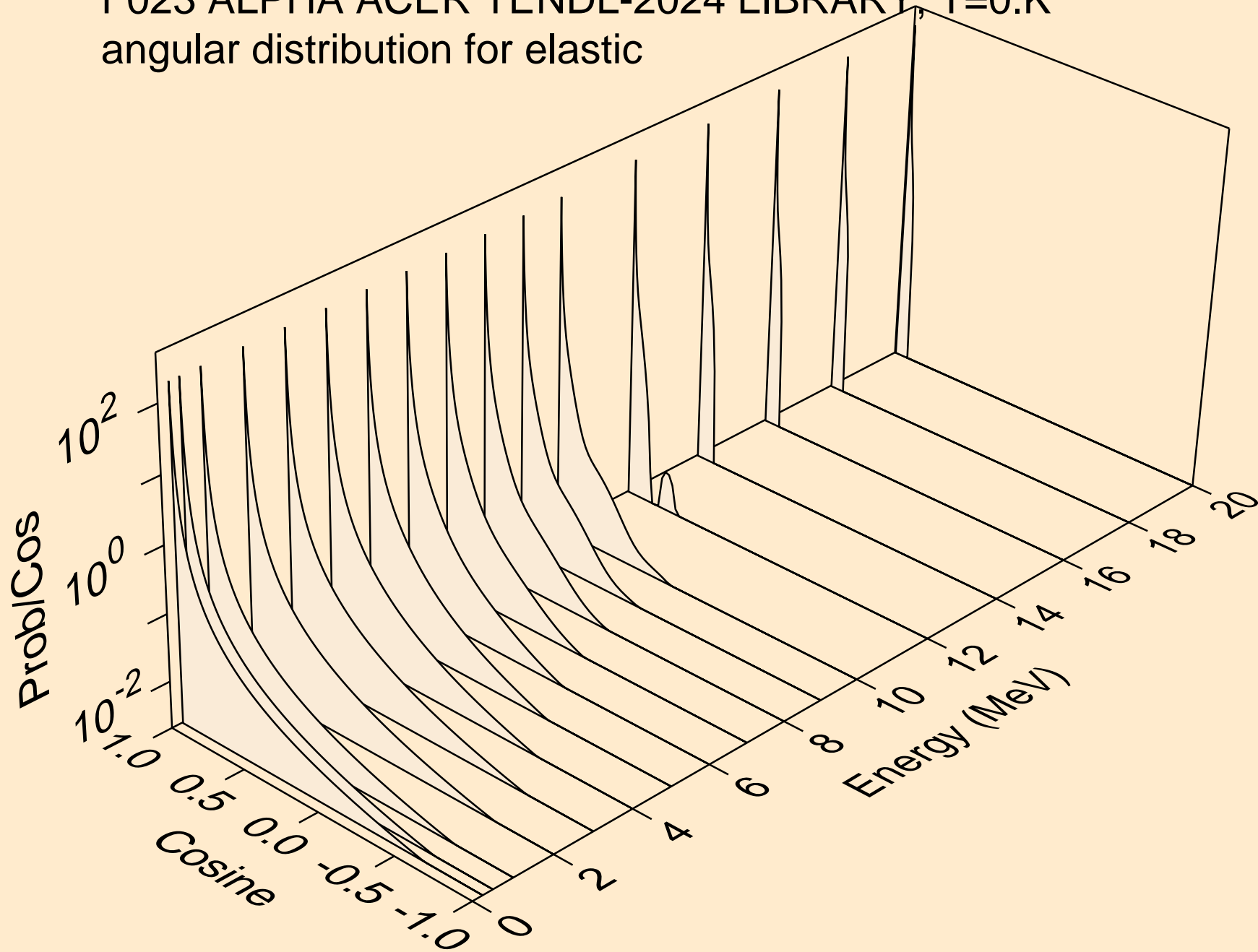

F023 ALPHA ACER TENDL-2024 LIBRARY: T=0.K
angular distribution for elastic

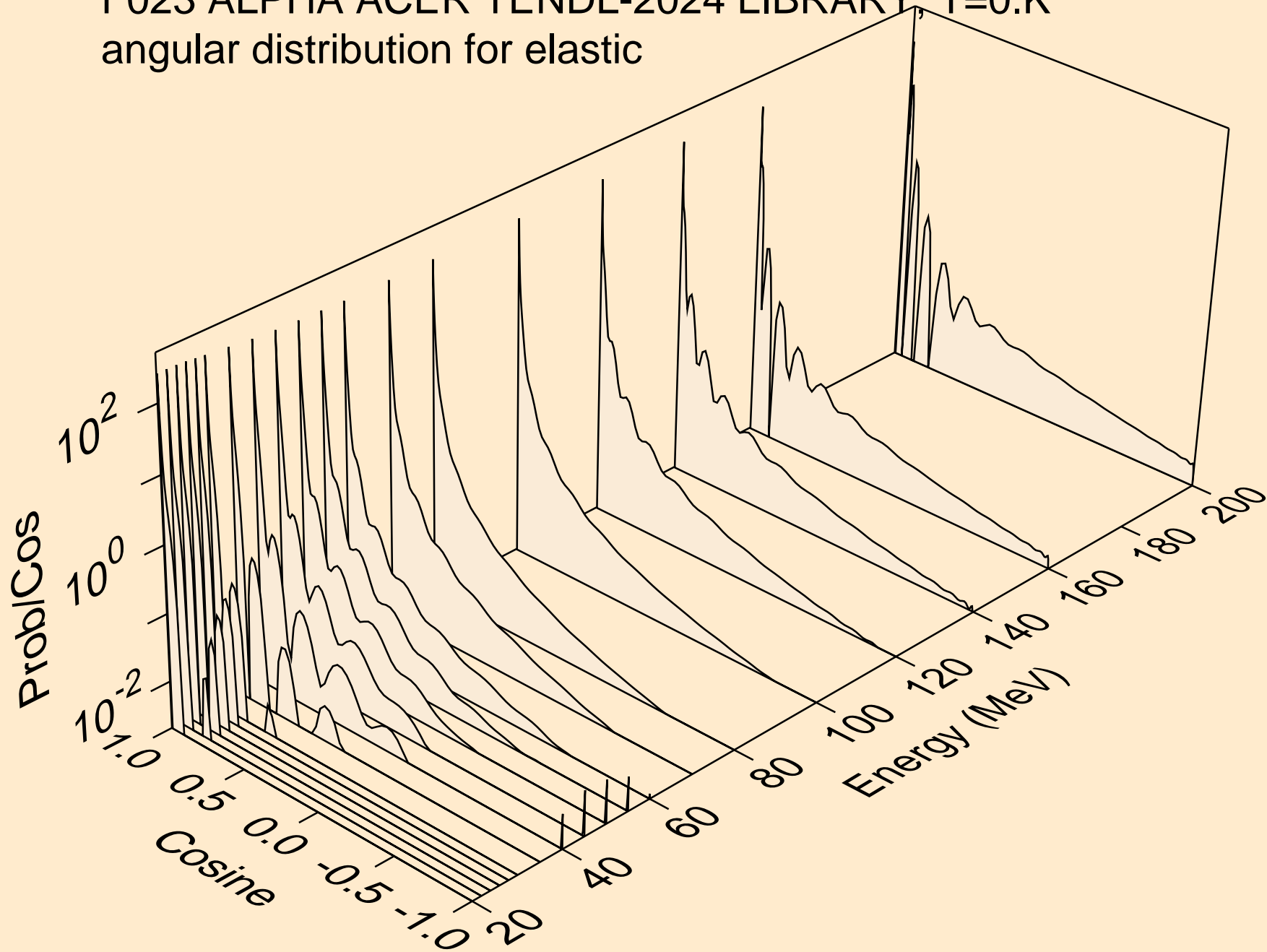

F023 ALPHA ACER TENDL-2024 LIBRARY; T=0.K
Alpha emission for (a,x)

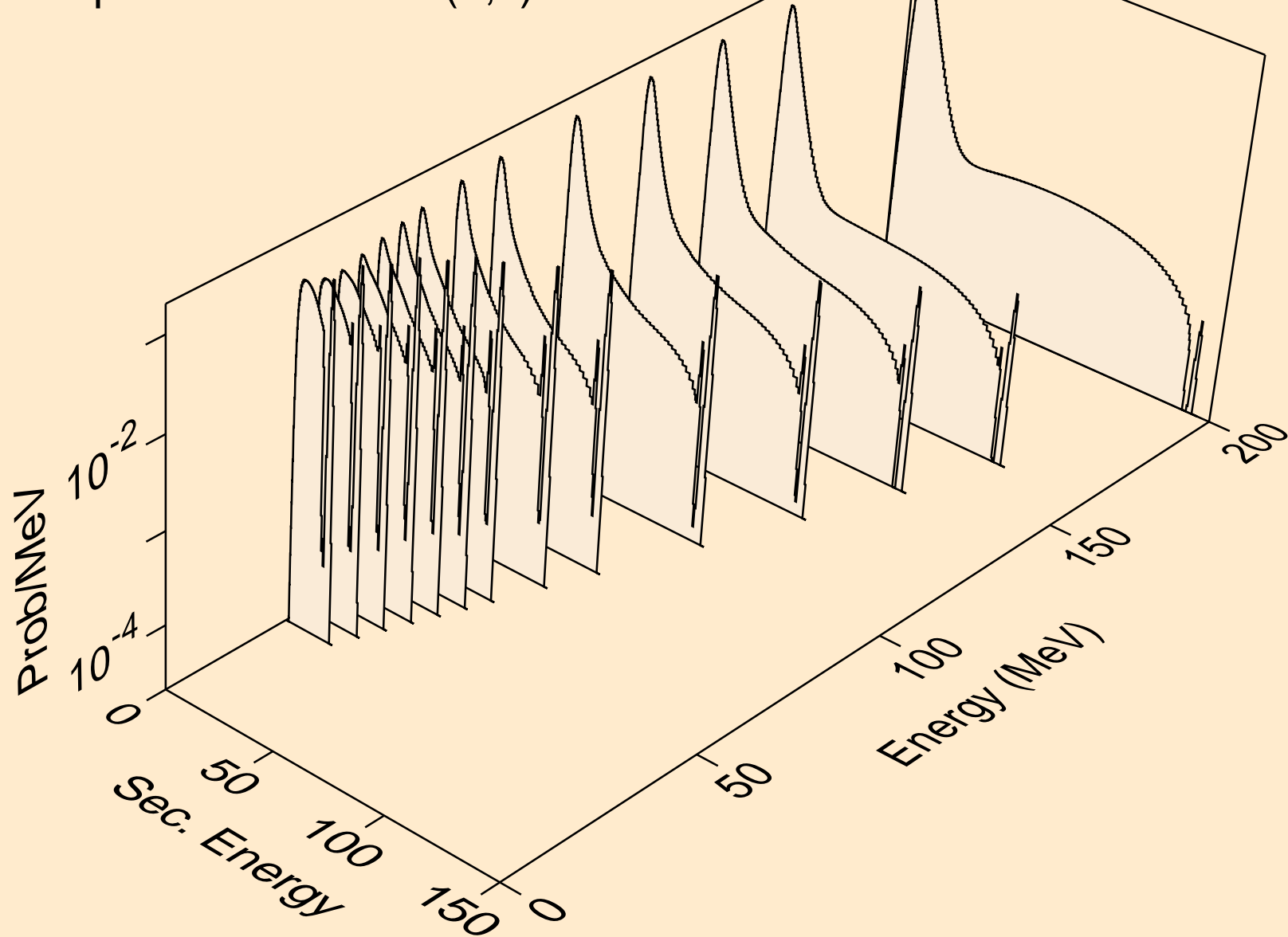

F023 ALPHA ACER TENDL-2024 LIBRARY; T=0.K
Alpha emission for (a,n*)a

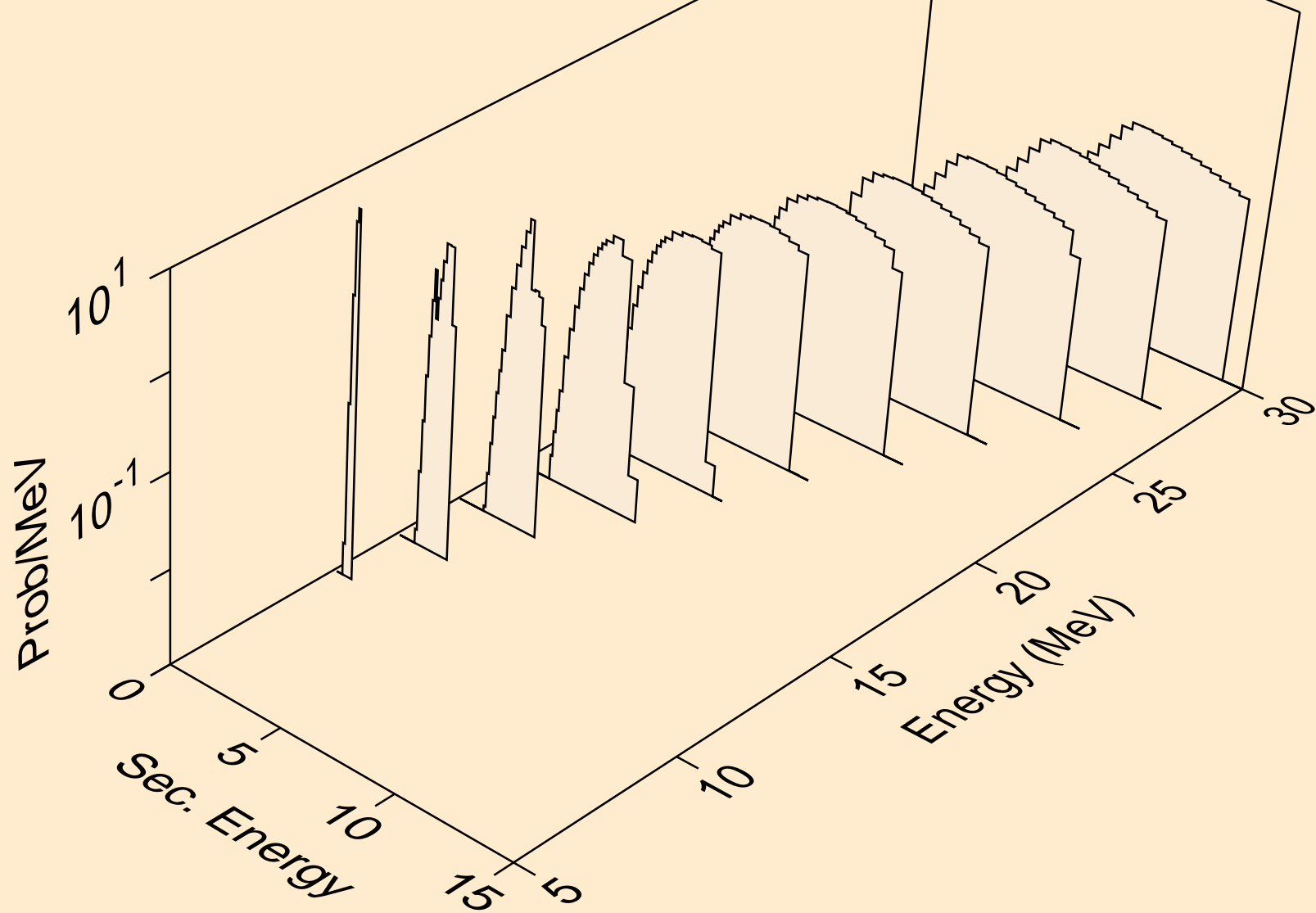

F023 ALPHA ACER TENDL-2024 LIBRARY; T=0.K
Alpha emission for (a,2n)a

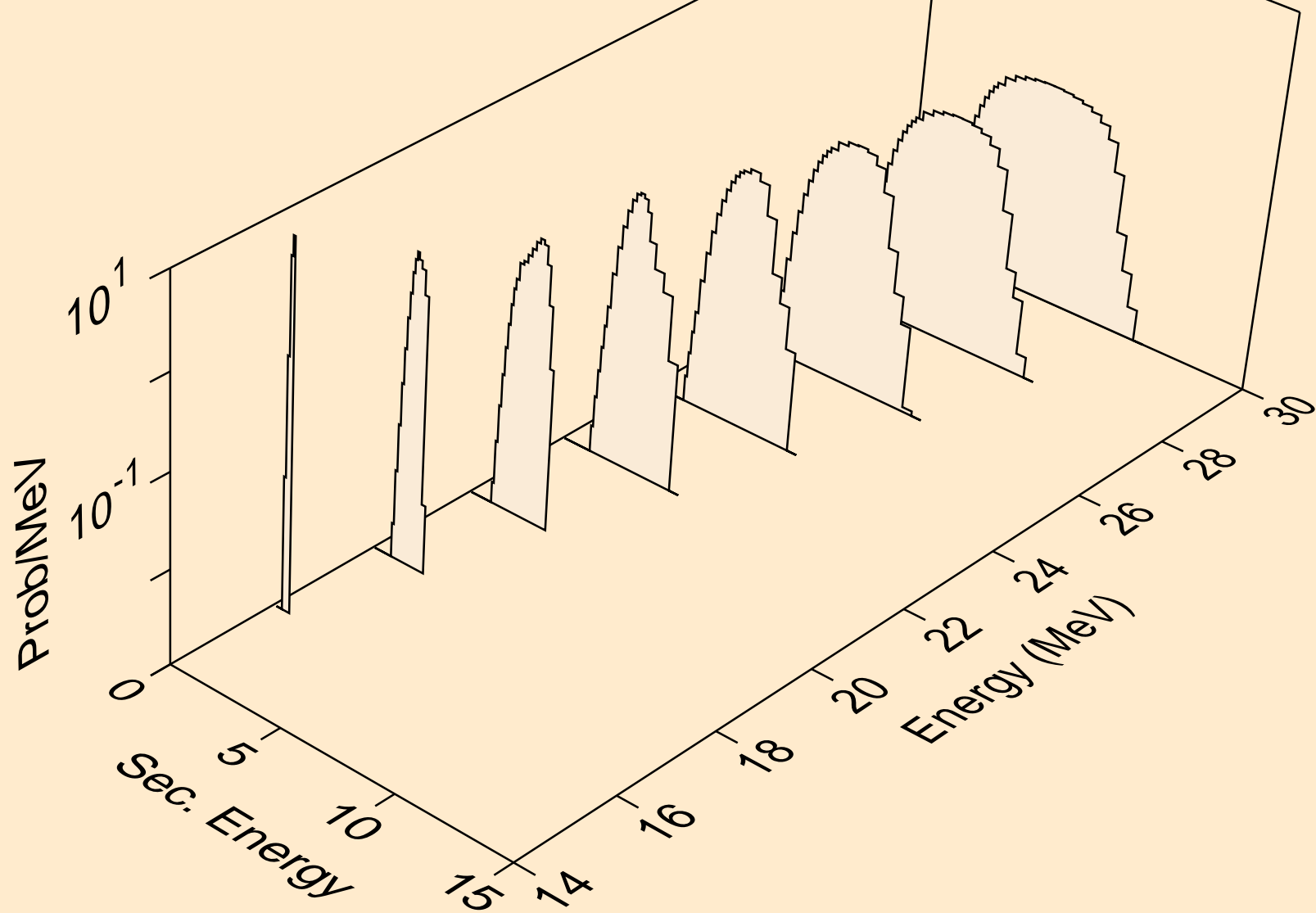

F023 ALPHA ACER TENDL-2024 LIBRARY; T=0.K
Alpha emission for (a,3n)a

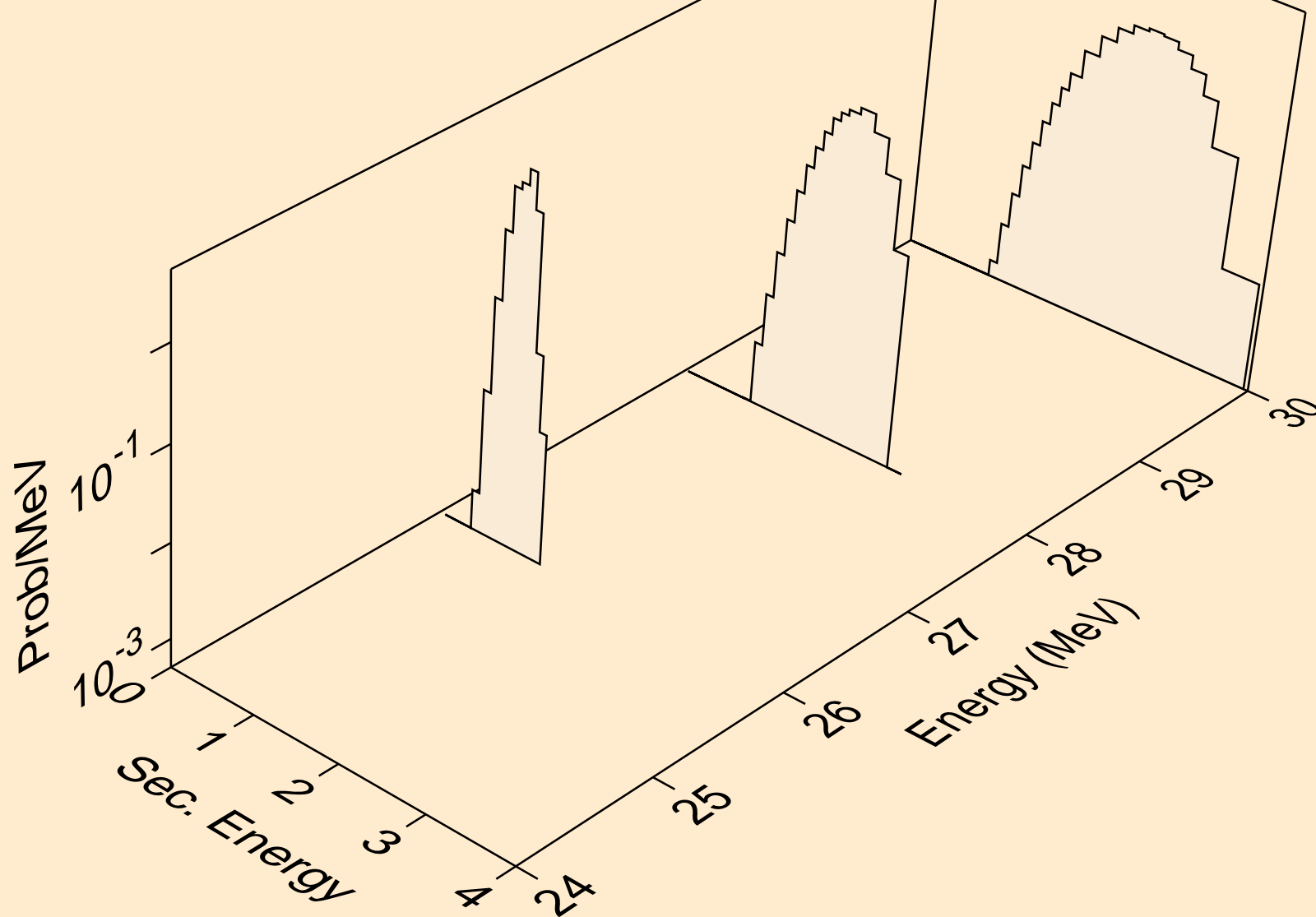

F023 ALPHA ACER TENDL-2024 LIBRARY; T=0.K
Alpha emission for (a,n*)2a

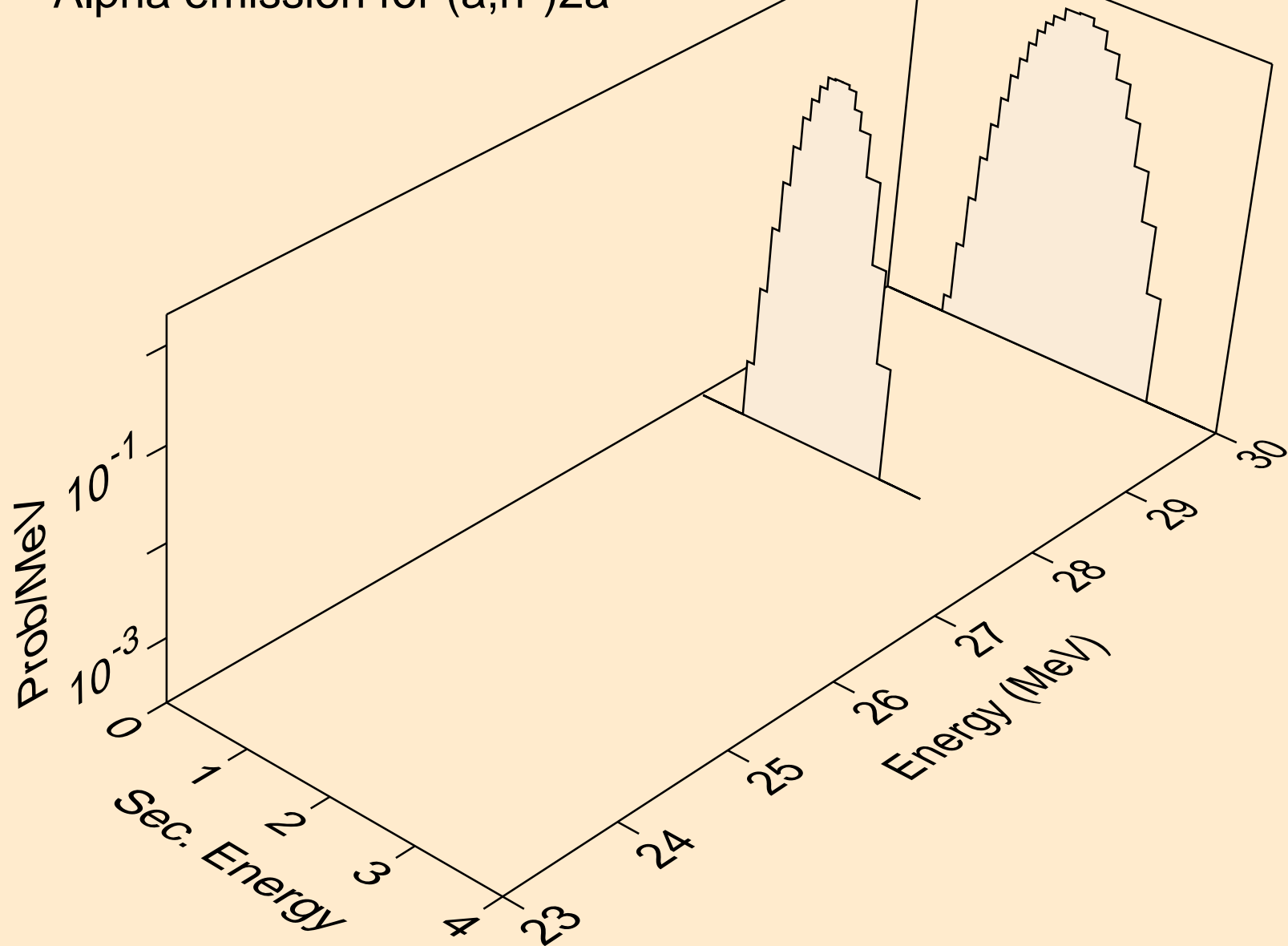

F023 ALPHA ACER TENDL-2024 LIBRARY; T=0.K
Alpha emission for inelastic

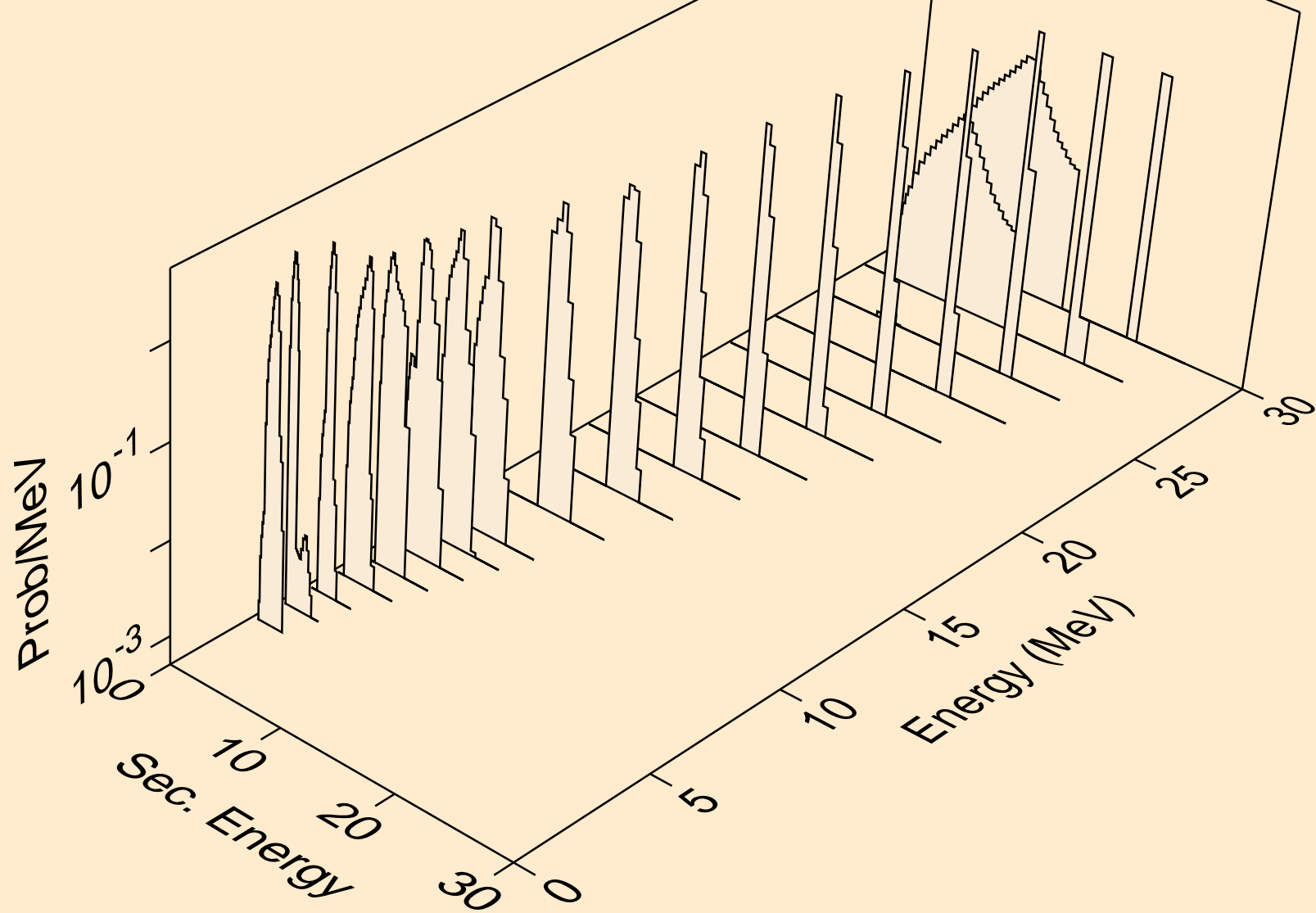

F023 ALPHA ACER TENDL-2024 LIBRARY; T=0.K
Alpha emission for (a,2a)

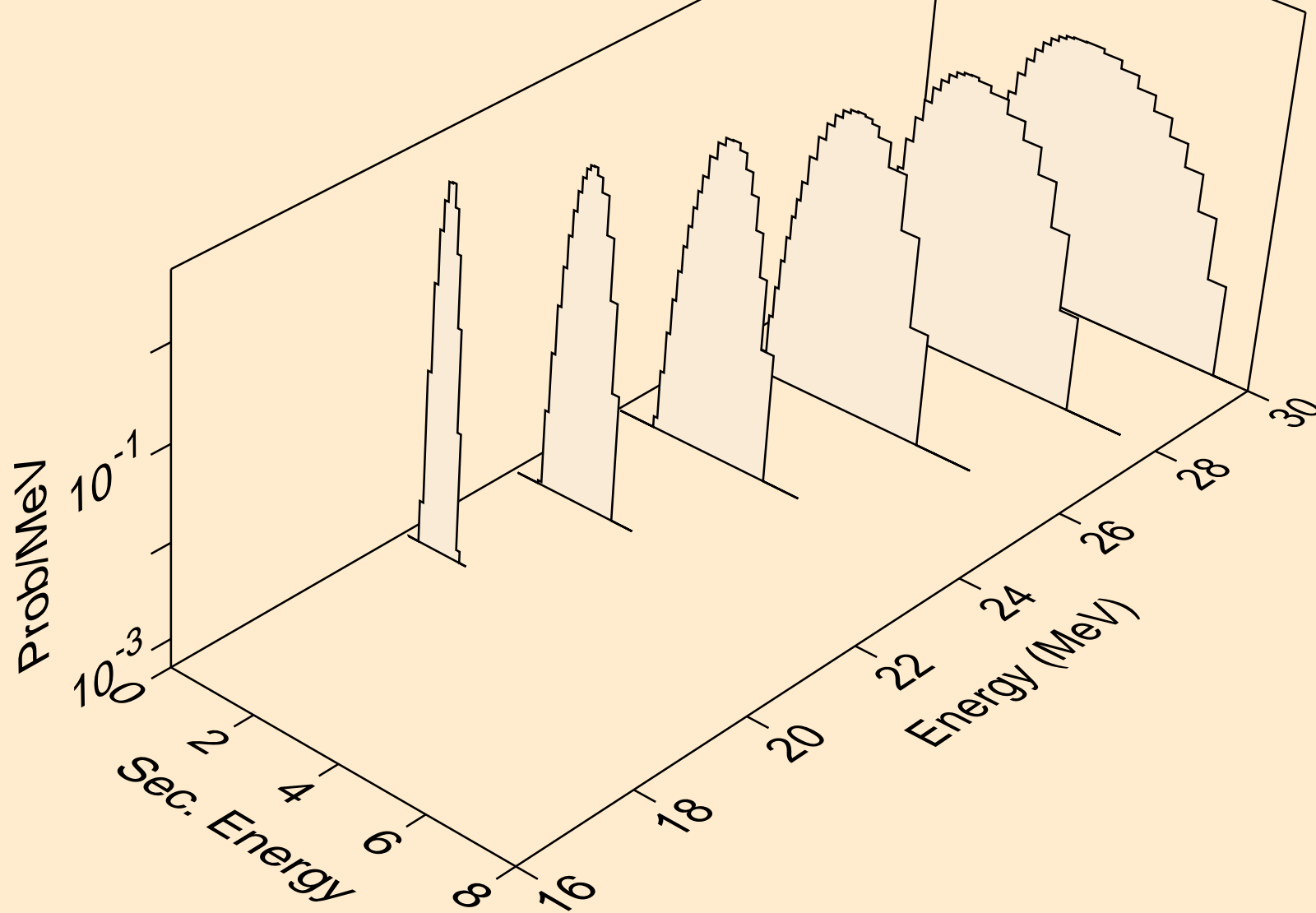

F023 ALPHA ACER TENDL-2024 LIBRARY; T=0.K
Alpha emission for (a,pa)

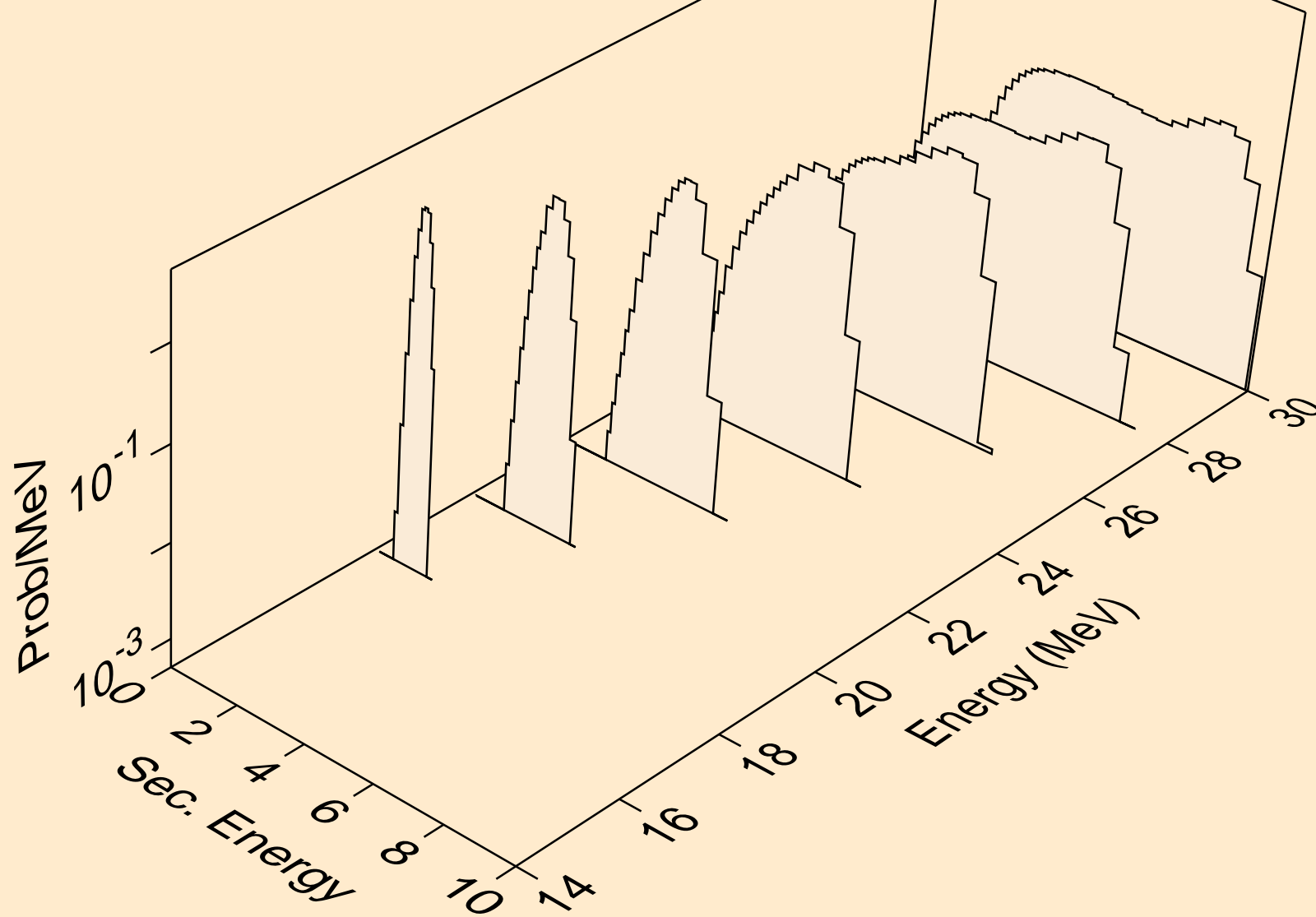

F023 ALPHA ACER TENDL-2024 LIBRARY; T=0.K
Alpha emission for (a,da)

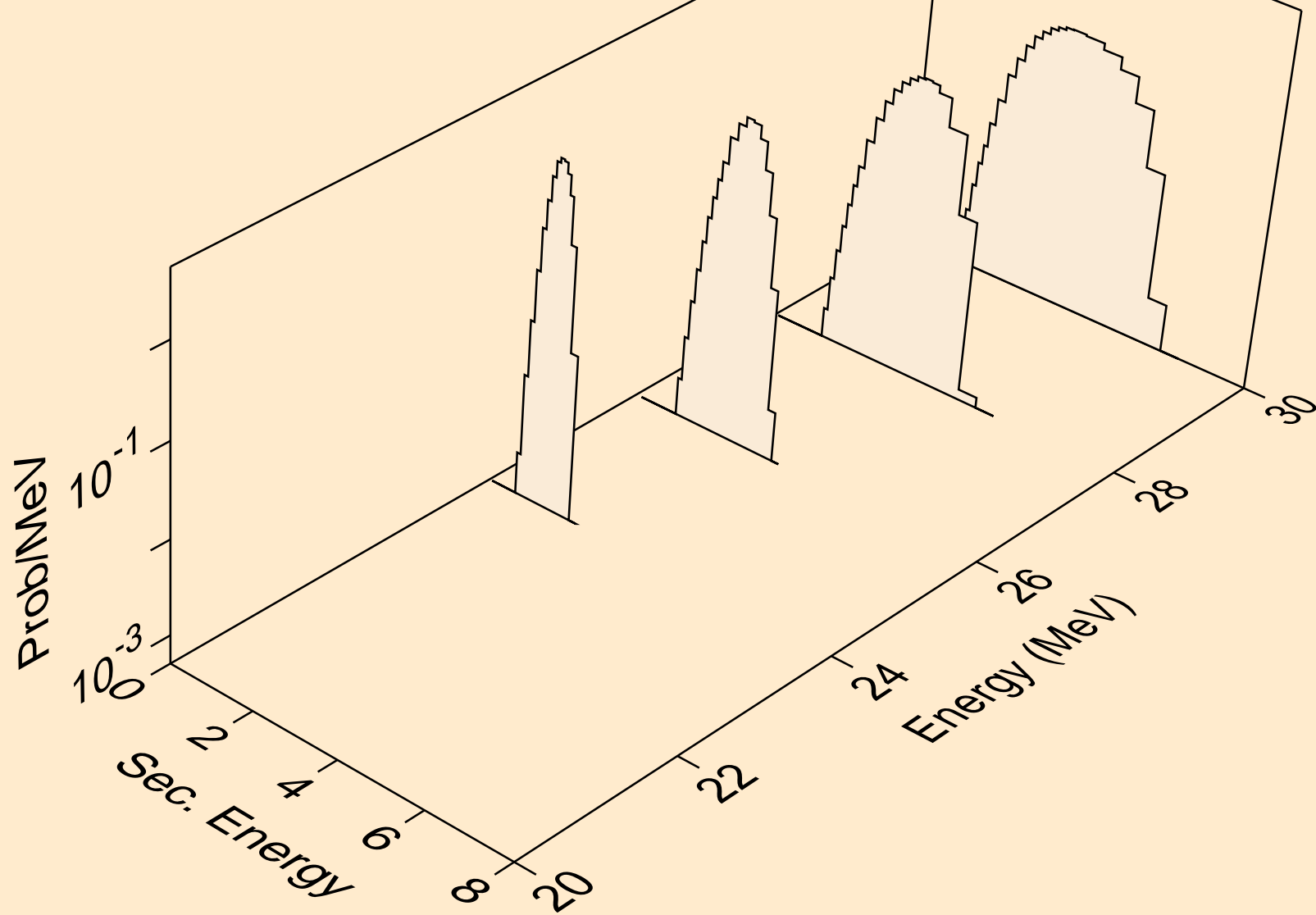

F023 ALPHA ACER TENDL-2024 LIBRARY; T=0.K
Photon emission for (z,n)

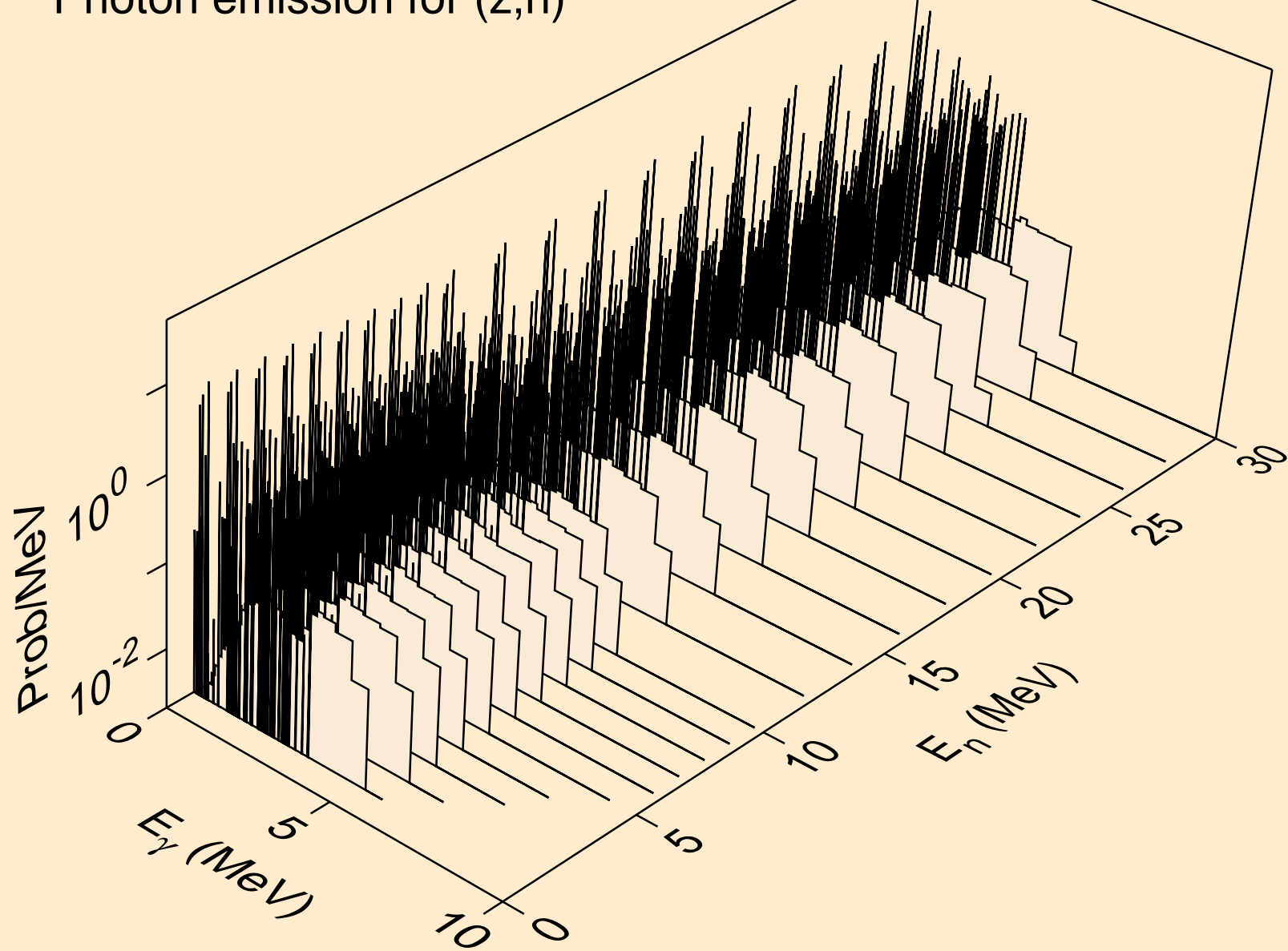

F023 ALPHA ACER TENDL-2024 LIBRARY; T=0.K
Photon emission for (z,x)

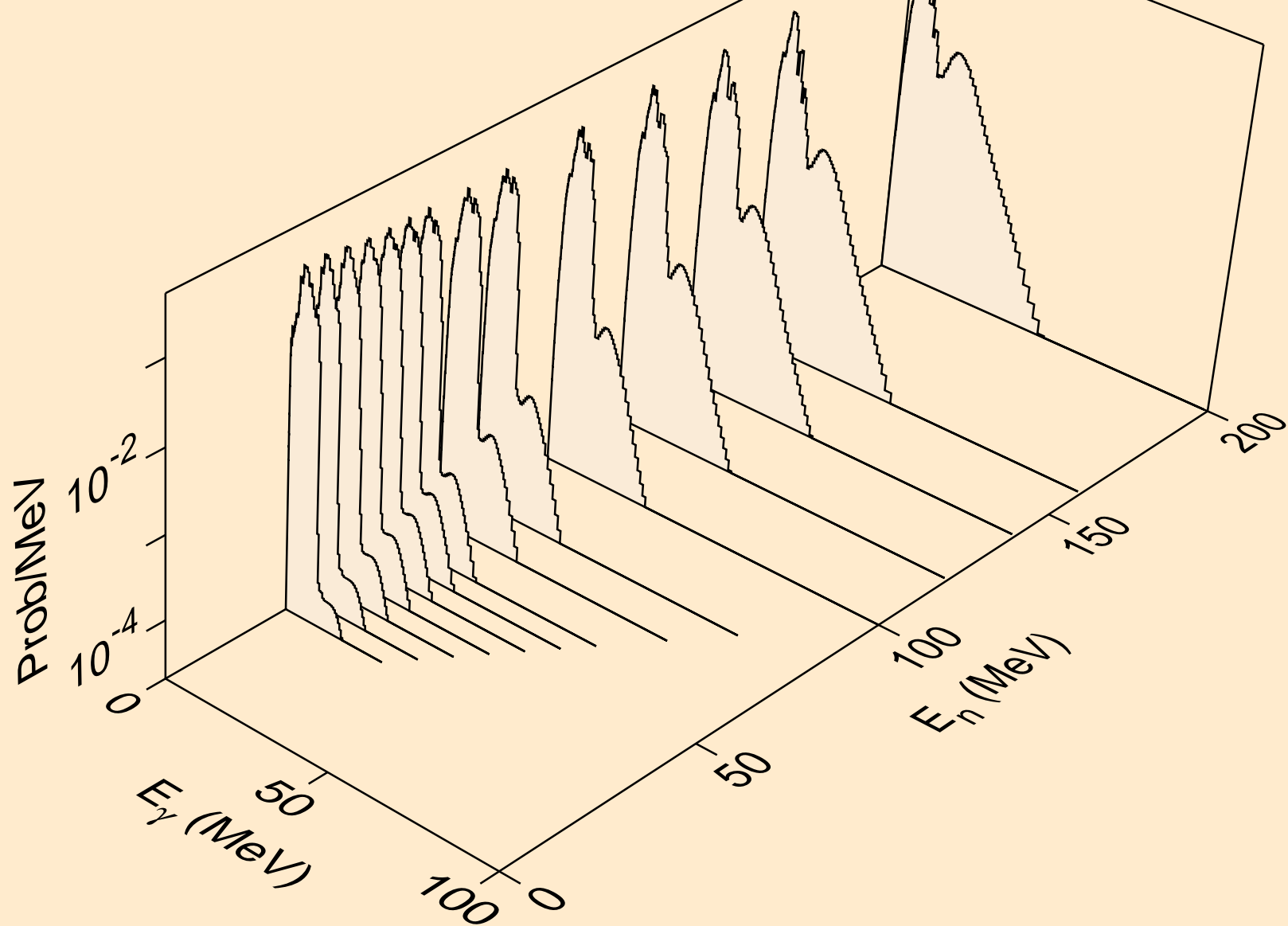

F023 ALPHA ACER TENDL-2024 LIBRARY; T=0.K
Photon emission for (n,2nd)

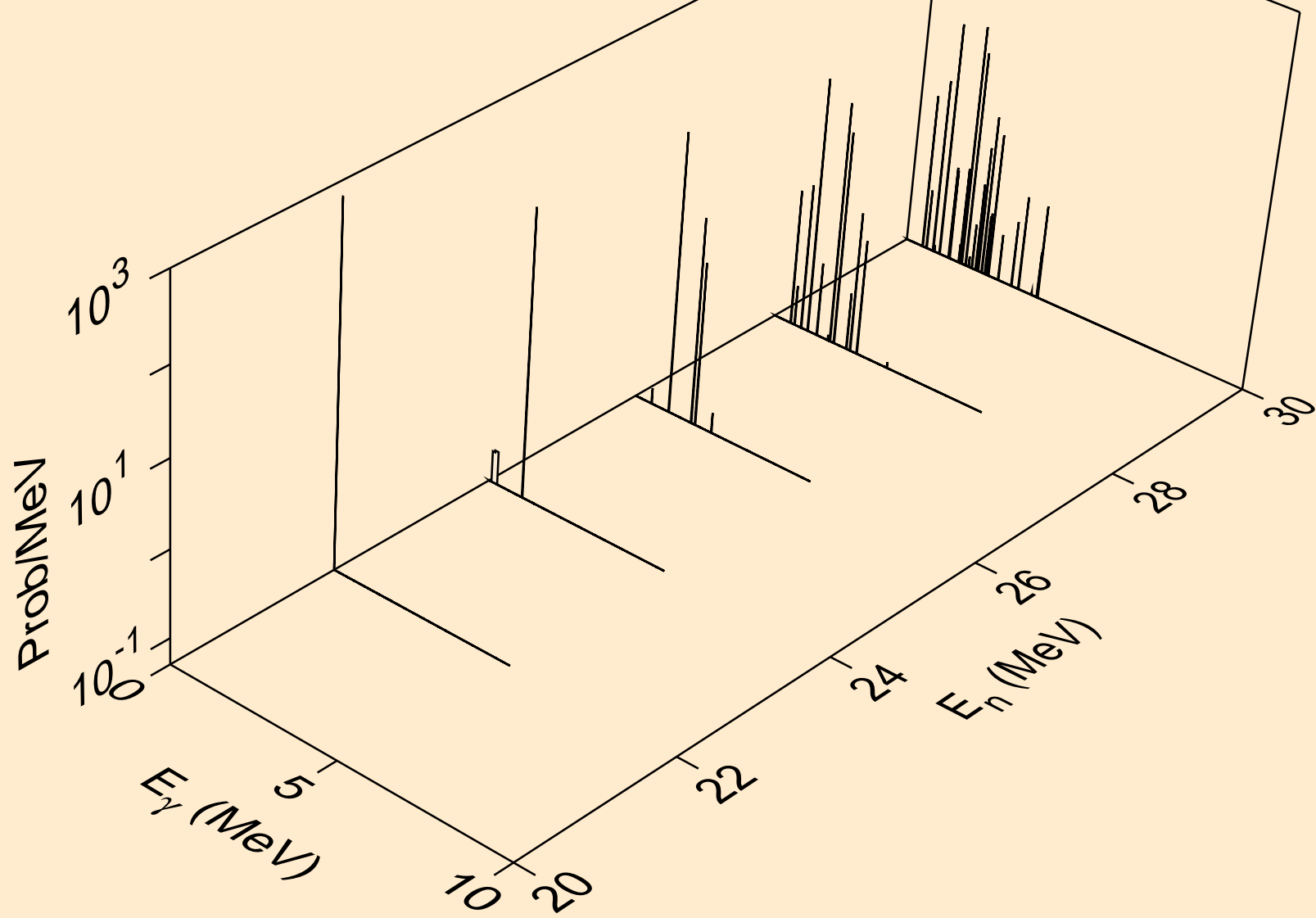

F023 ALPHA ACER TENDL-2024 LIBRARY; T=0.K
Photon emission for (n,2n)

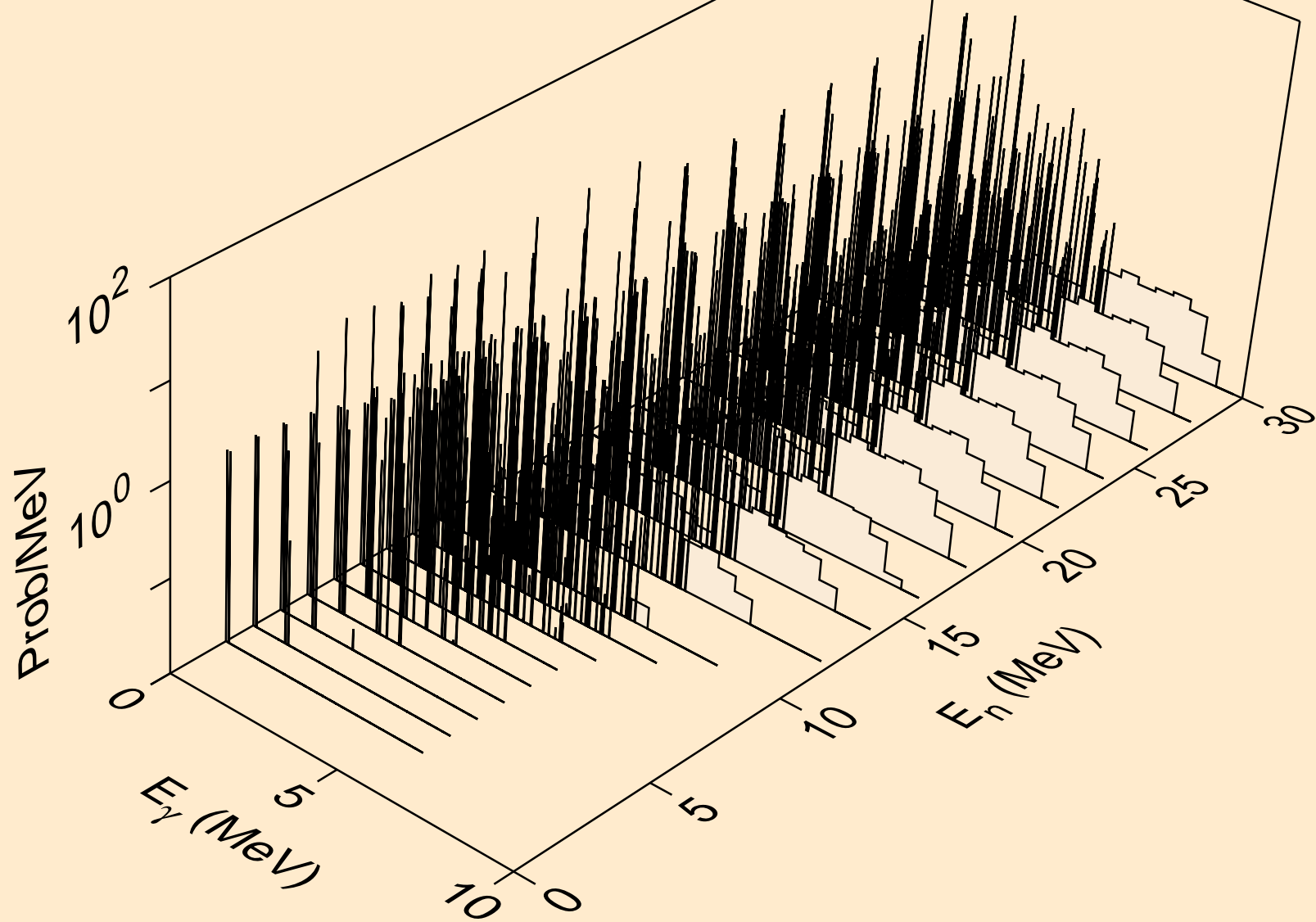

F023 ALPHA ACER TENDL-2024 LIBRARY; T=0.K
Photon emission for (n,3n)

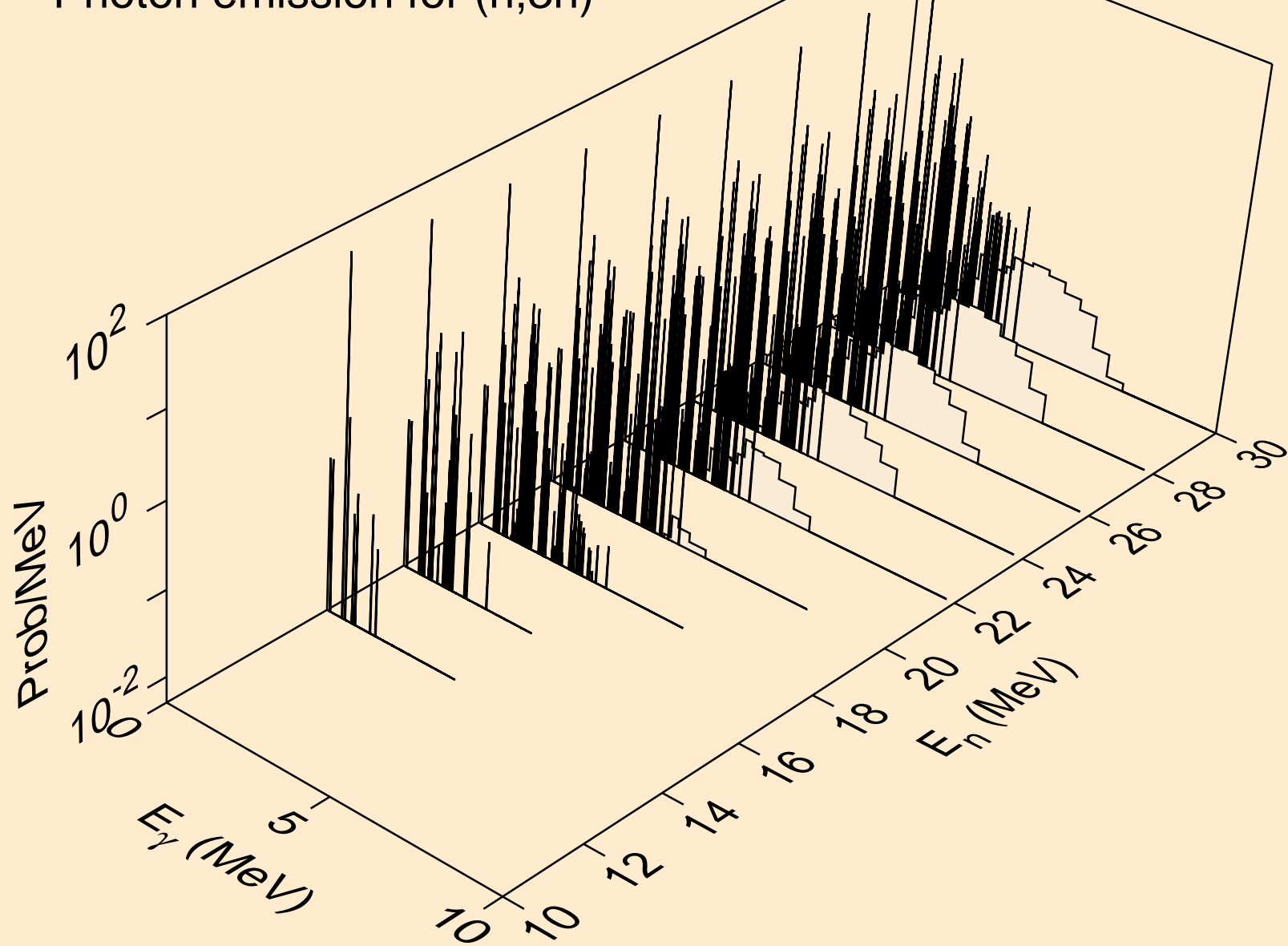

F023 ALPHA ACER TENDL-2024 LIBRARY; T=0.K
Photon emission for (n,n*)a

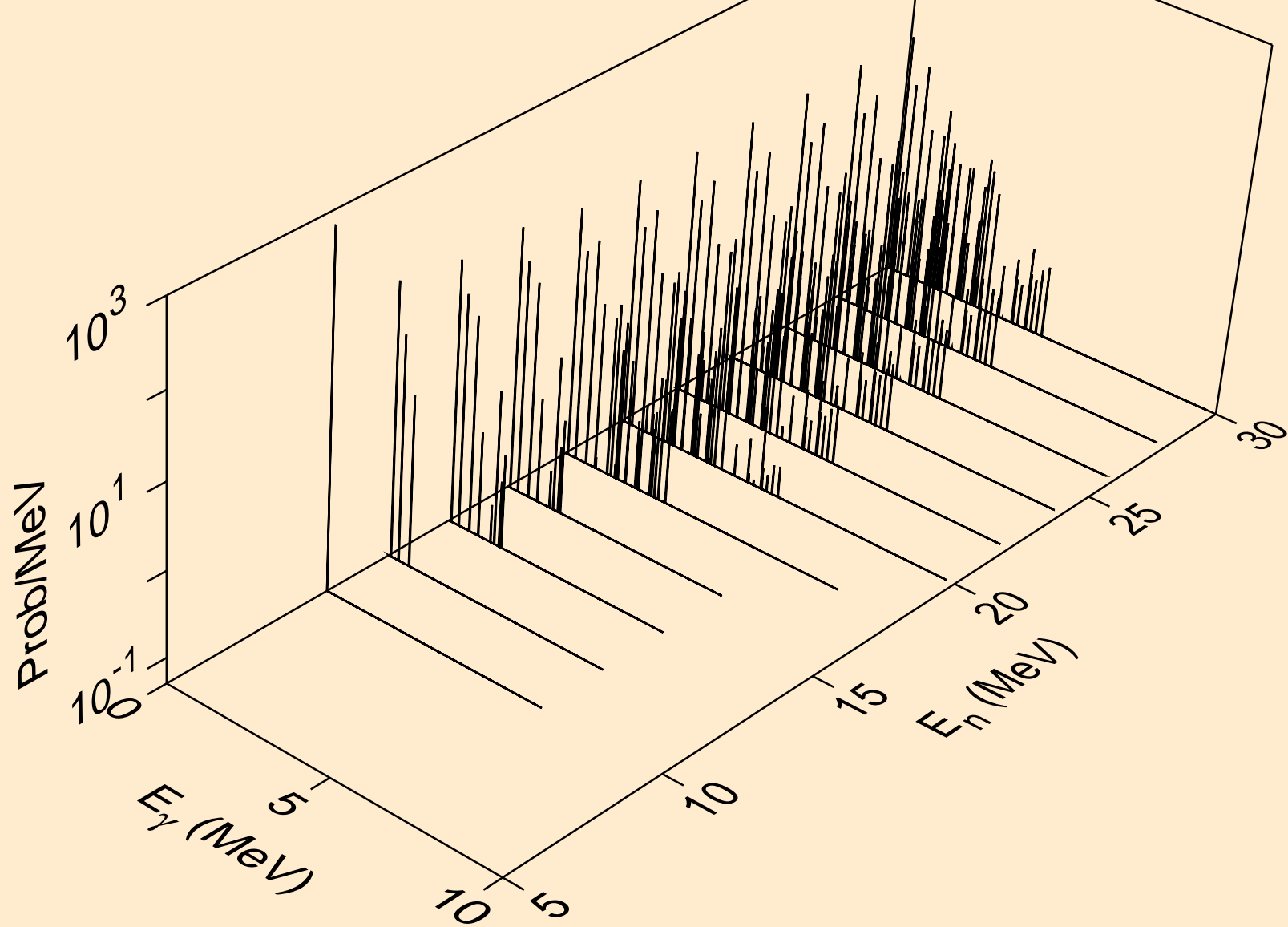

F023 ALPHA ACER TENDL-2024 LIBRARY; T=0.K
Photon emission for (n,2n)a

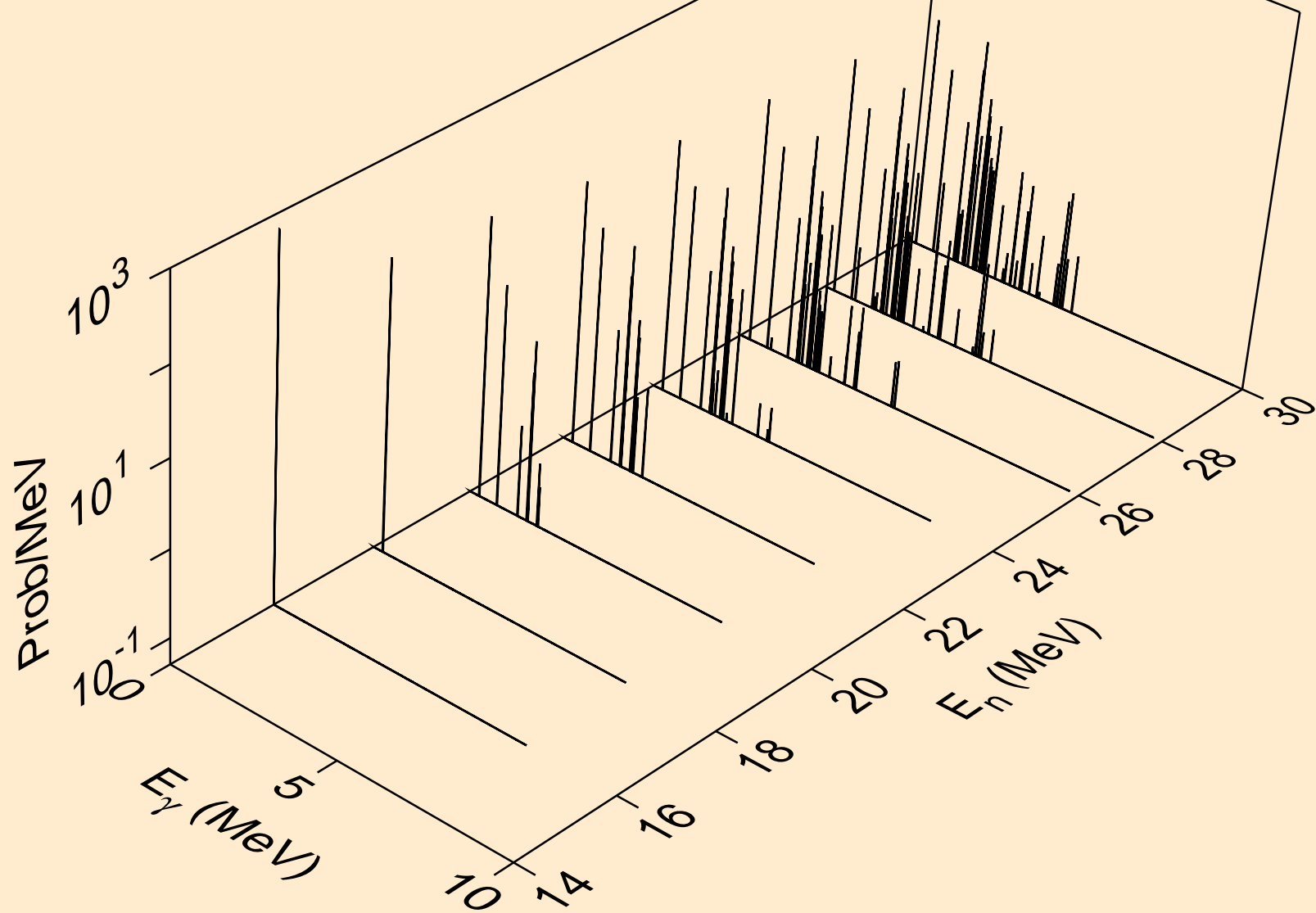

F023 ALPHA ACER TENDL-2024 LIBRARY; T=0.K
Photon emission for (n,3n)a

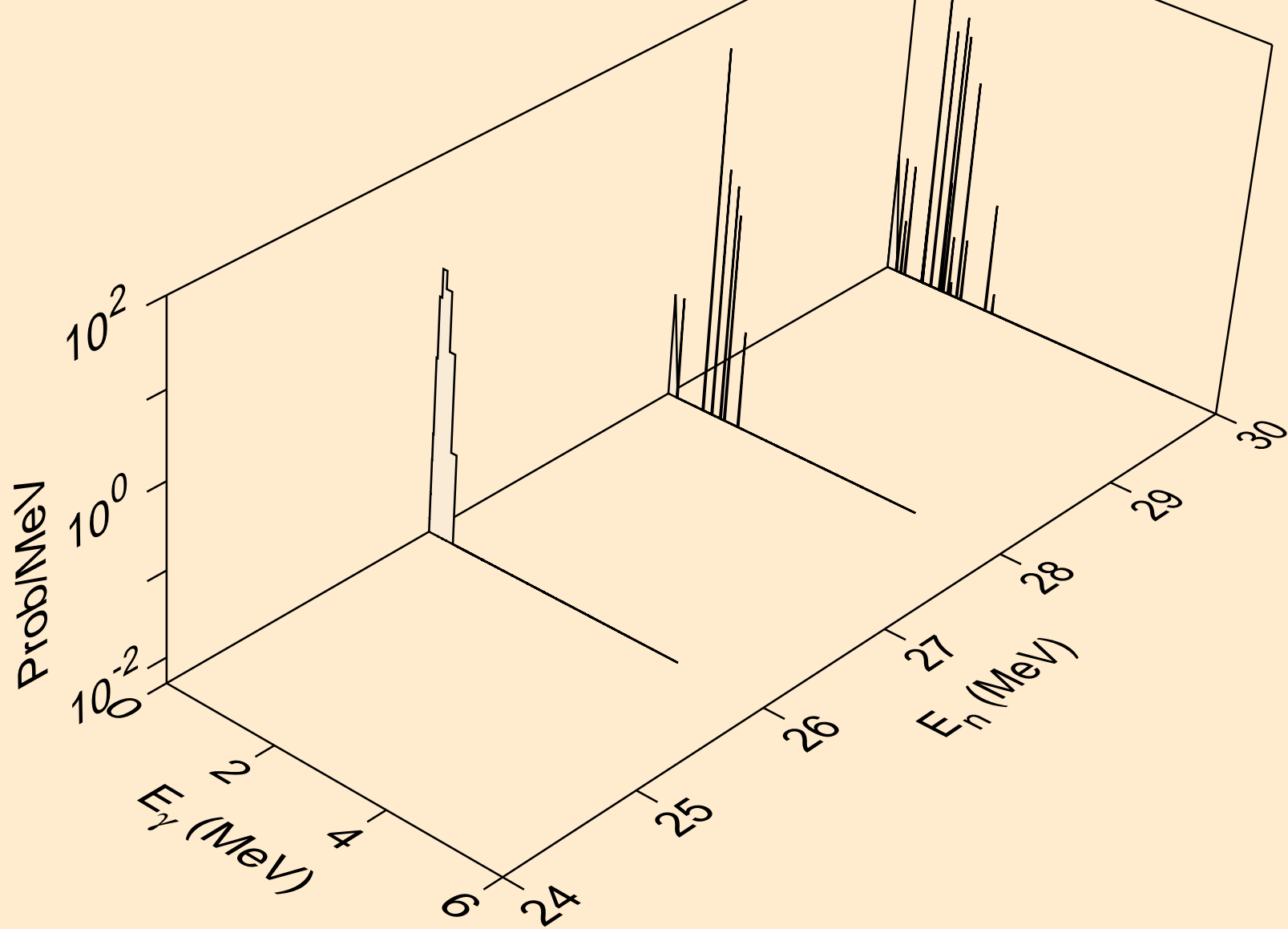

F023 ALPHA ACER TENDL-2024 LIBRARY; T=0.K
Photon emission for (n,n*)p

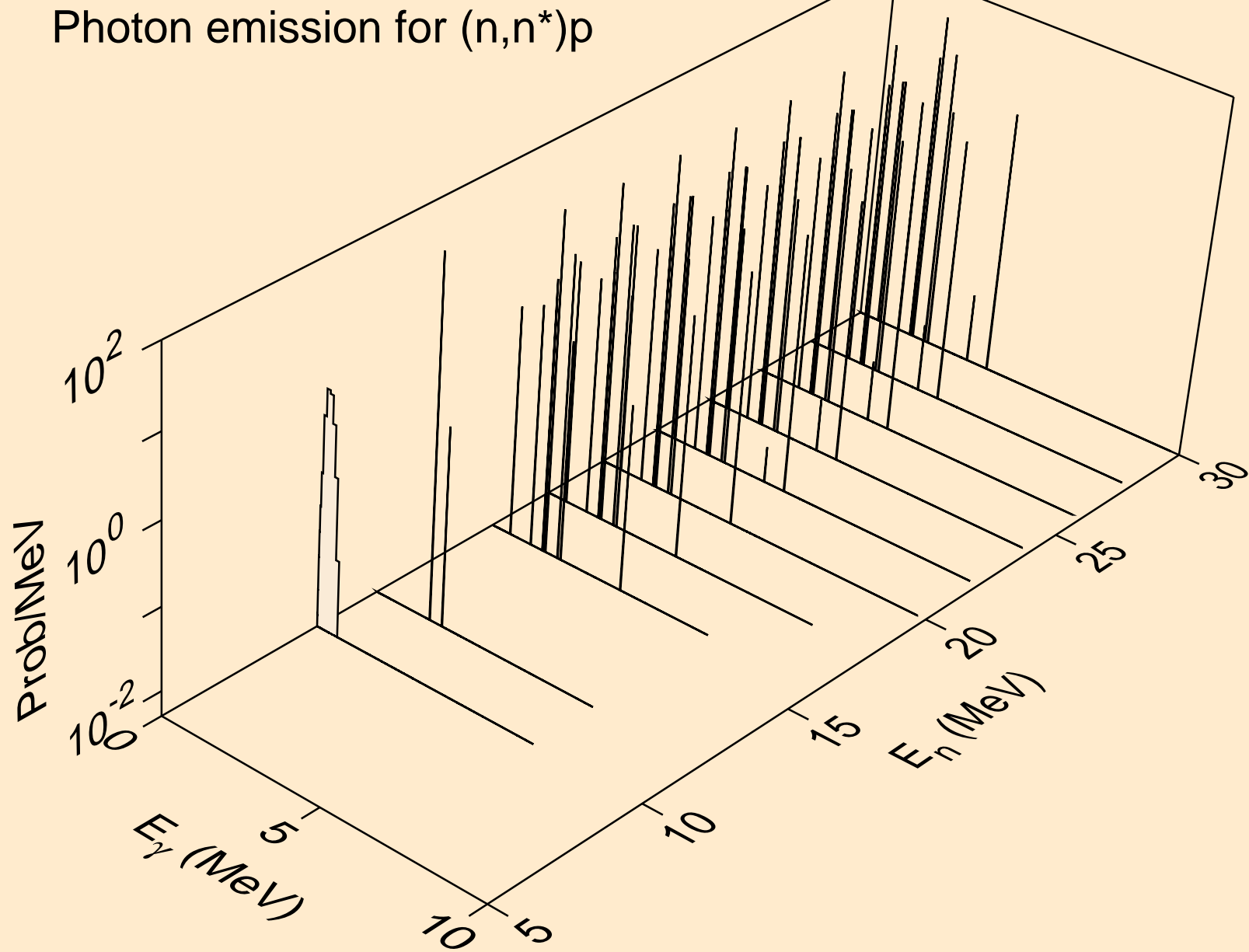

F023 ALPHA ACER TENDL-2024 LIBRARY; T=0.K
Photon emission for (n,n*)2a

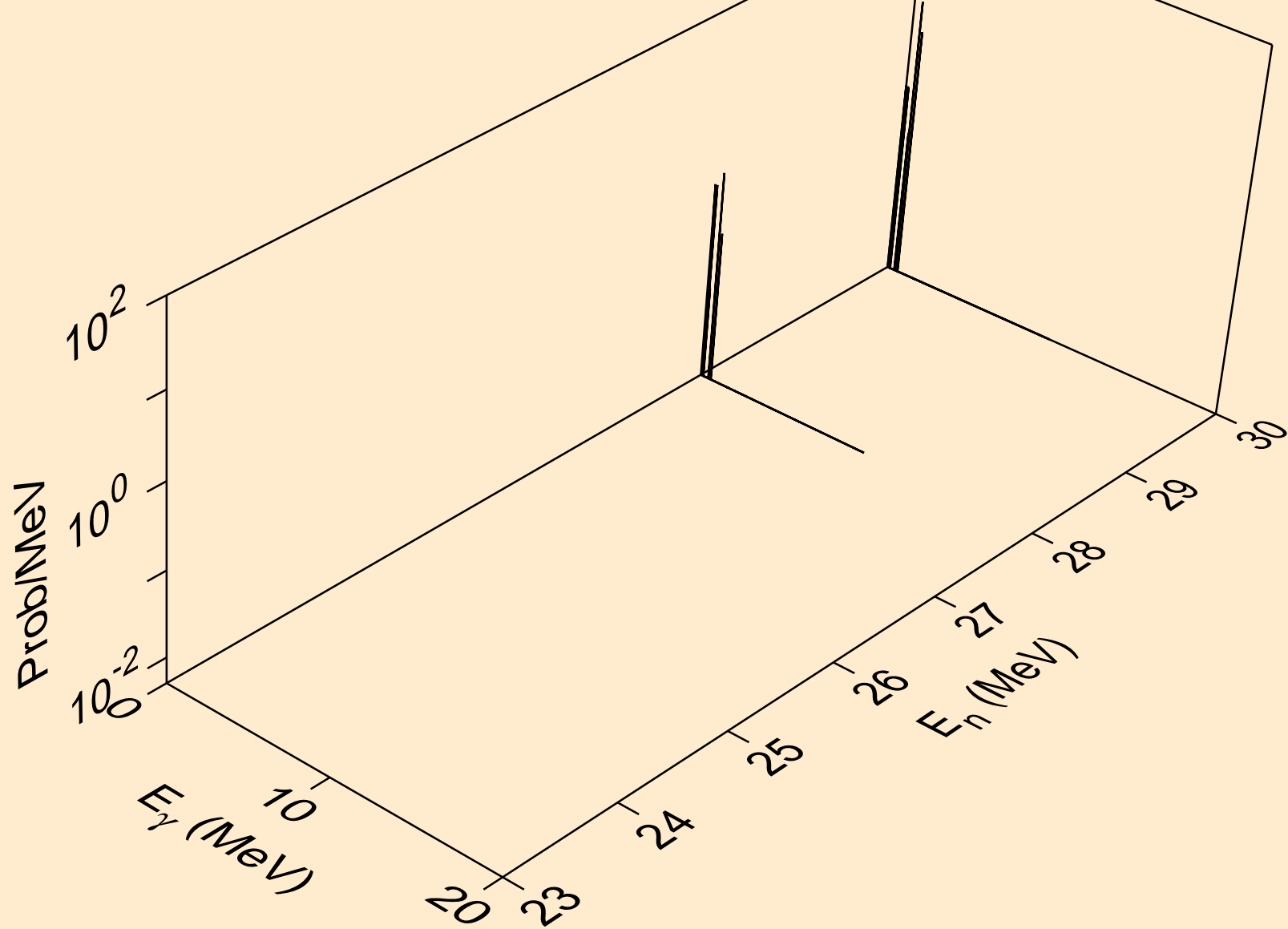

F023 ALPHA ACER TENDL-2024 LIBRARY; T=0.K
Photon emission for (n,n*)d

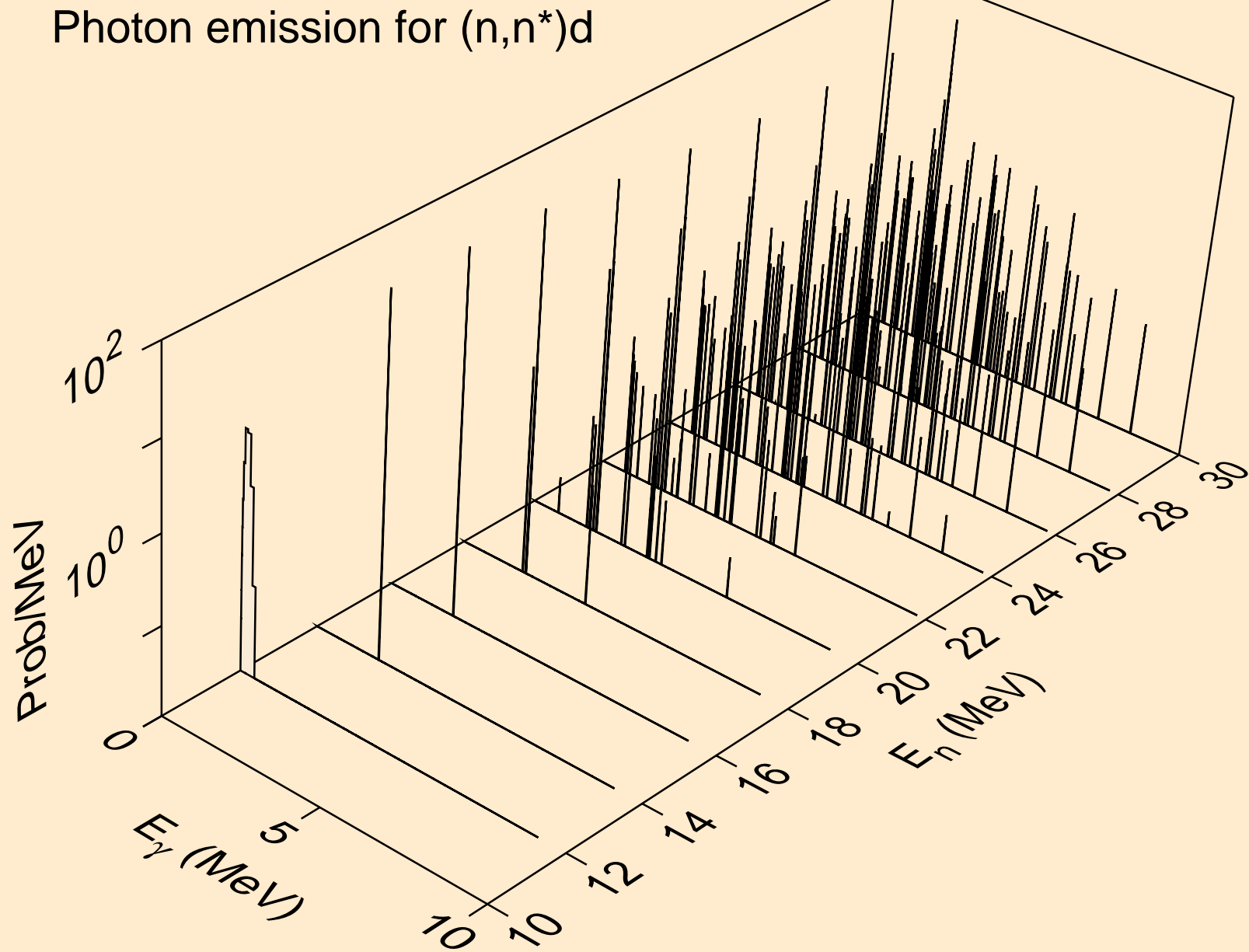

F023 ALPHA ACER TENDL-2024 LIBRARY; T=0.K
Photon emission for (n,n*)t

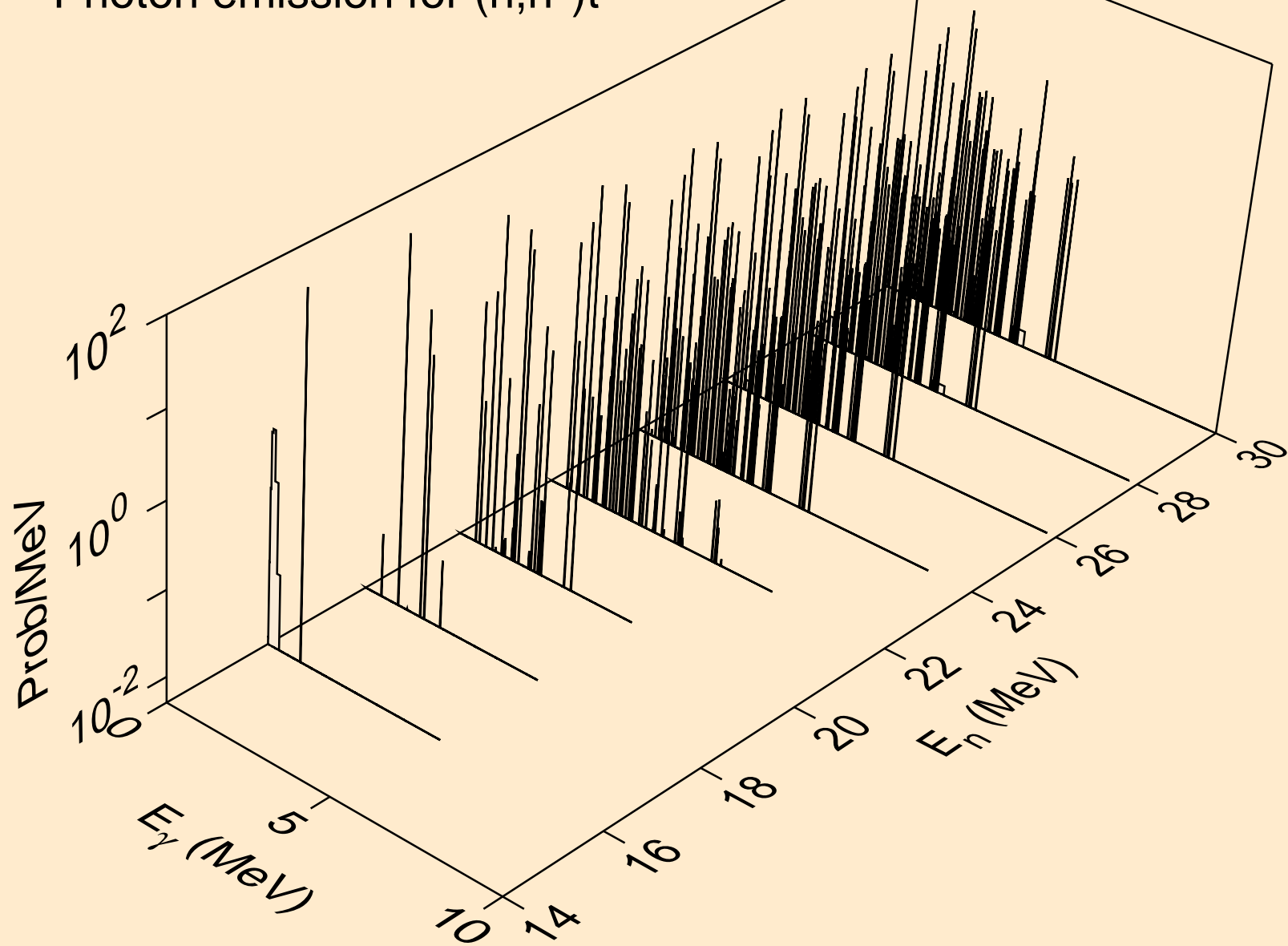

F023 ALPHA ACER TENDL-2024 LIBRARY; T=0.K
Photon emission for (n,n*)he3

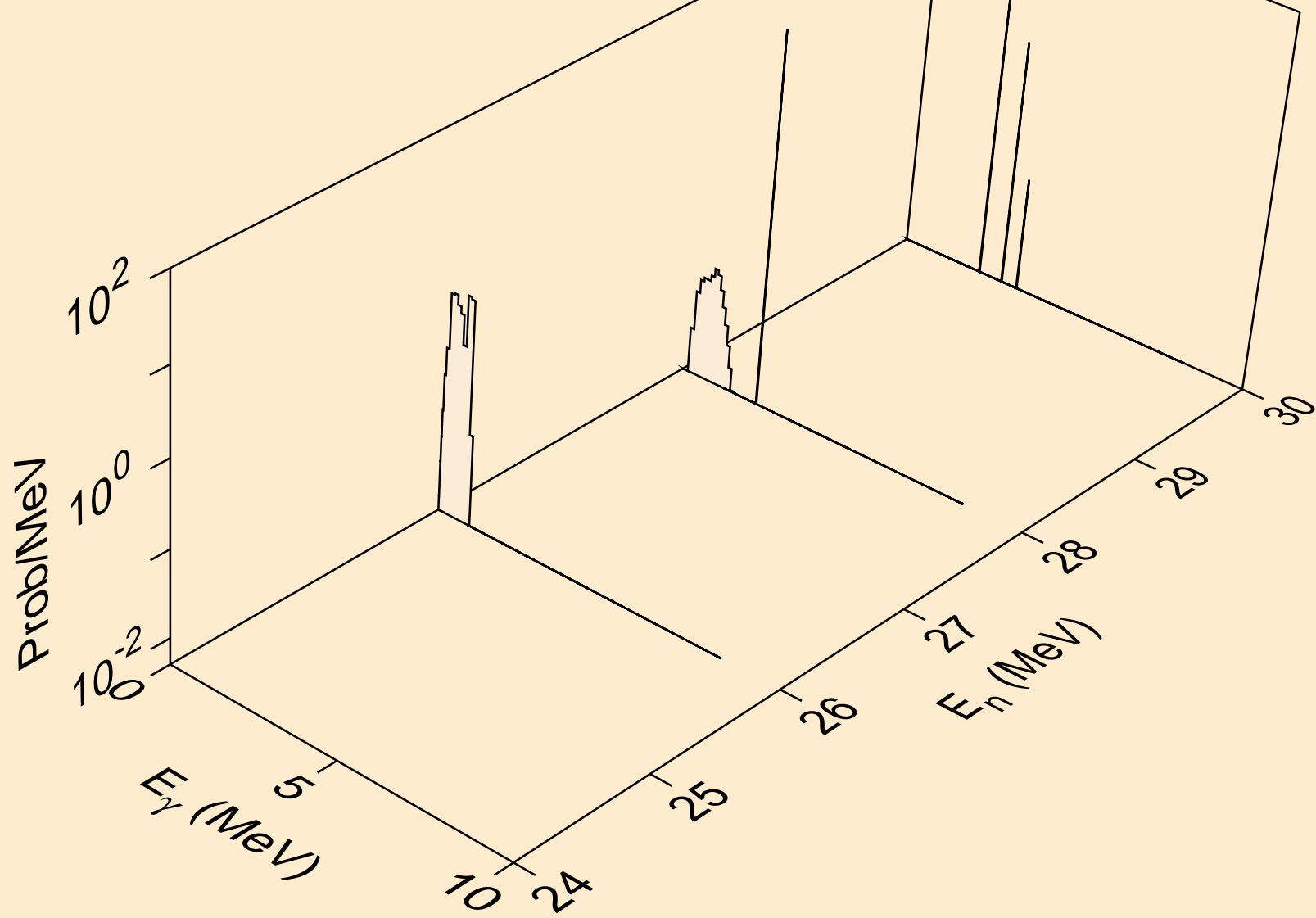

F023 ALPHA ACER TENDL-2024 LIBRARY; T=0.K
Photon emission for (n,4n)

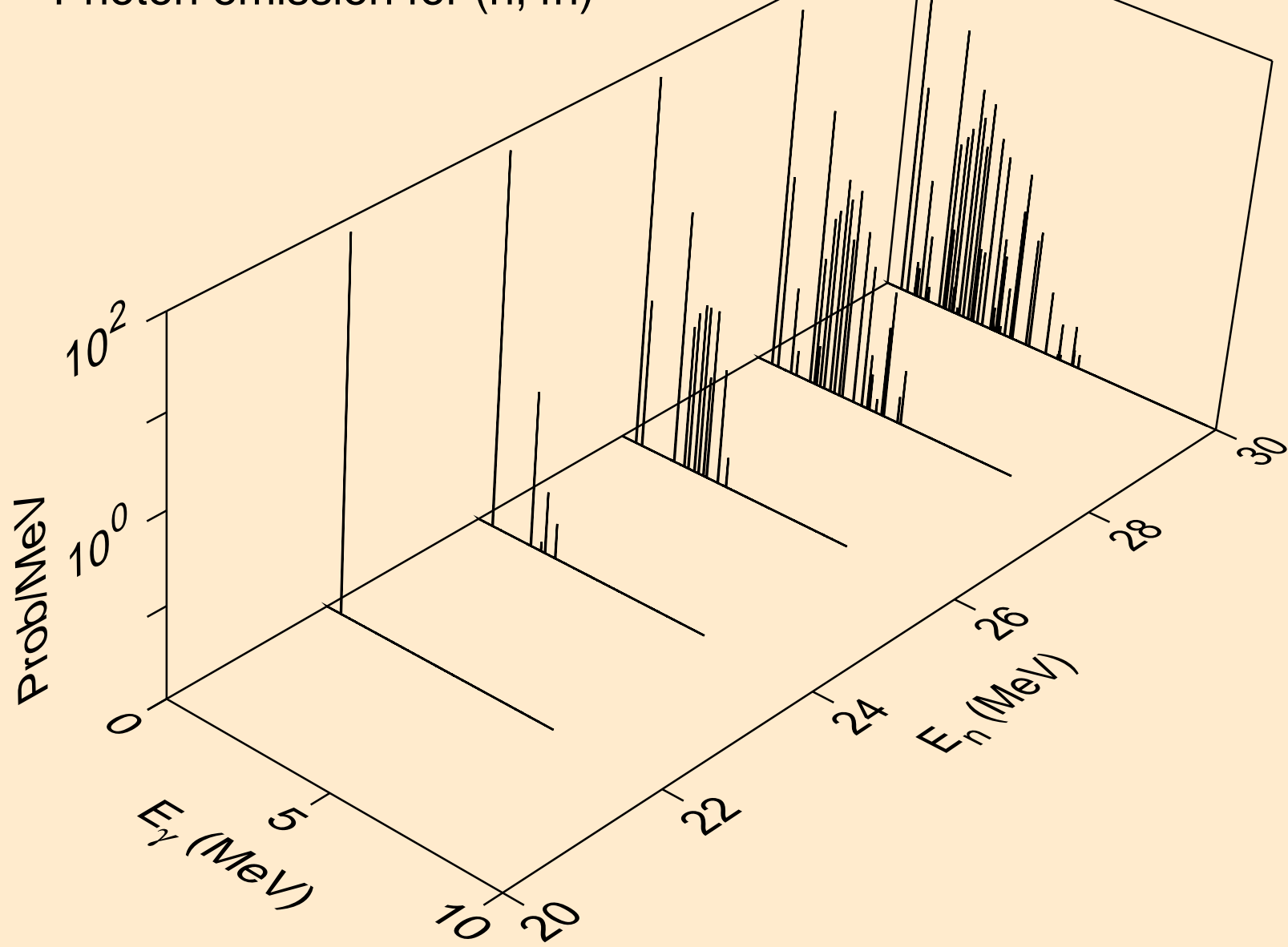

F023 ALPHA ACER TENDL-2024 LIBRARY; T=0.K
Photon emission for (n,2np)

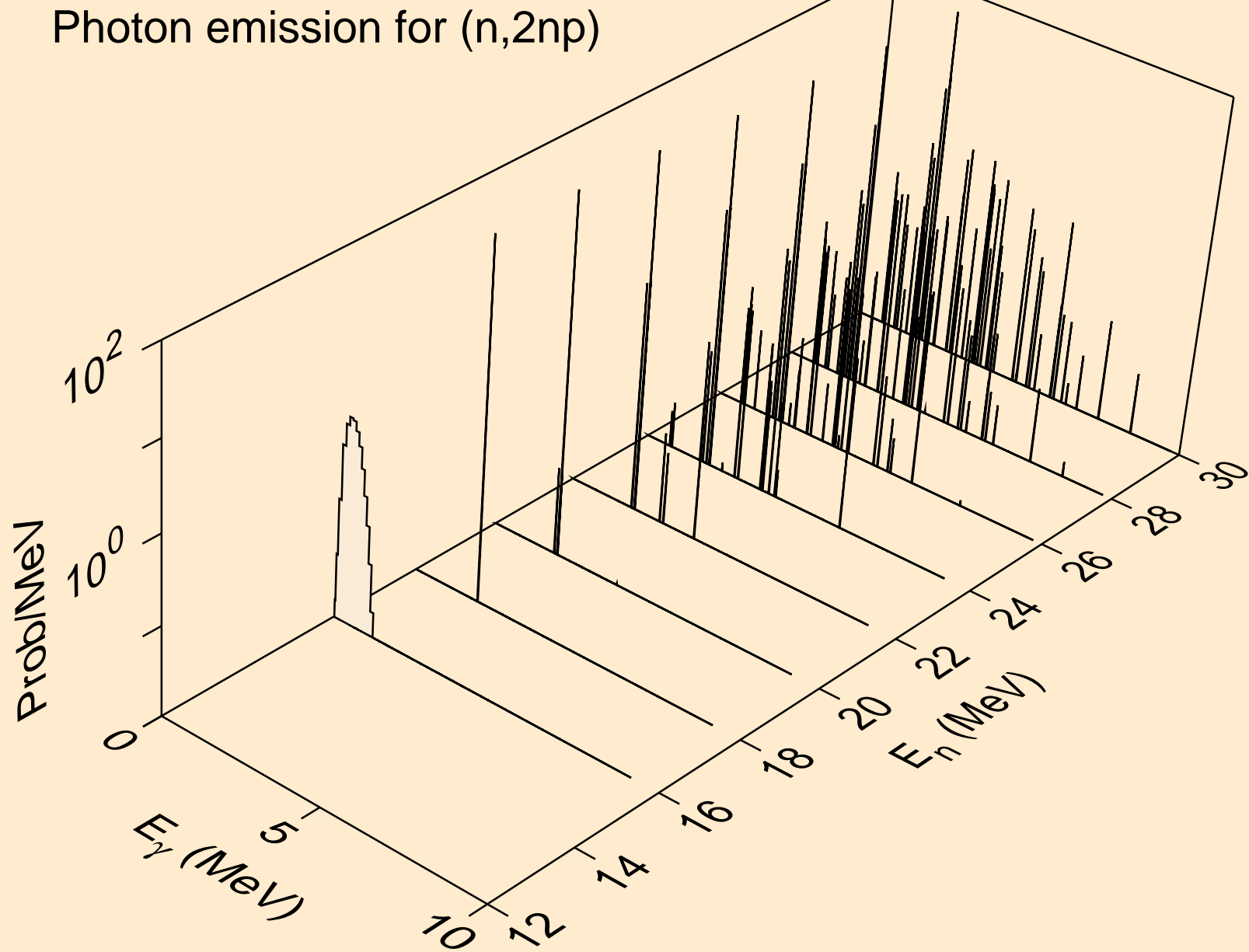

F023 ALPHA ACER TENDL-2024 LIBRARY; T=0.K
Photon emission for (n,3np)

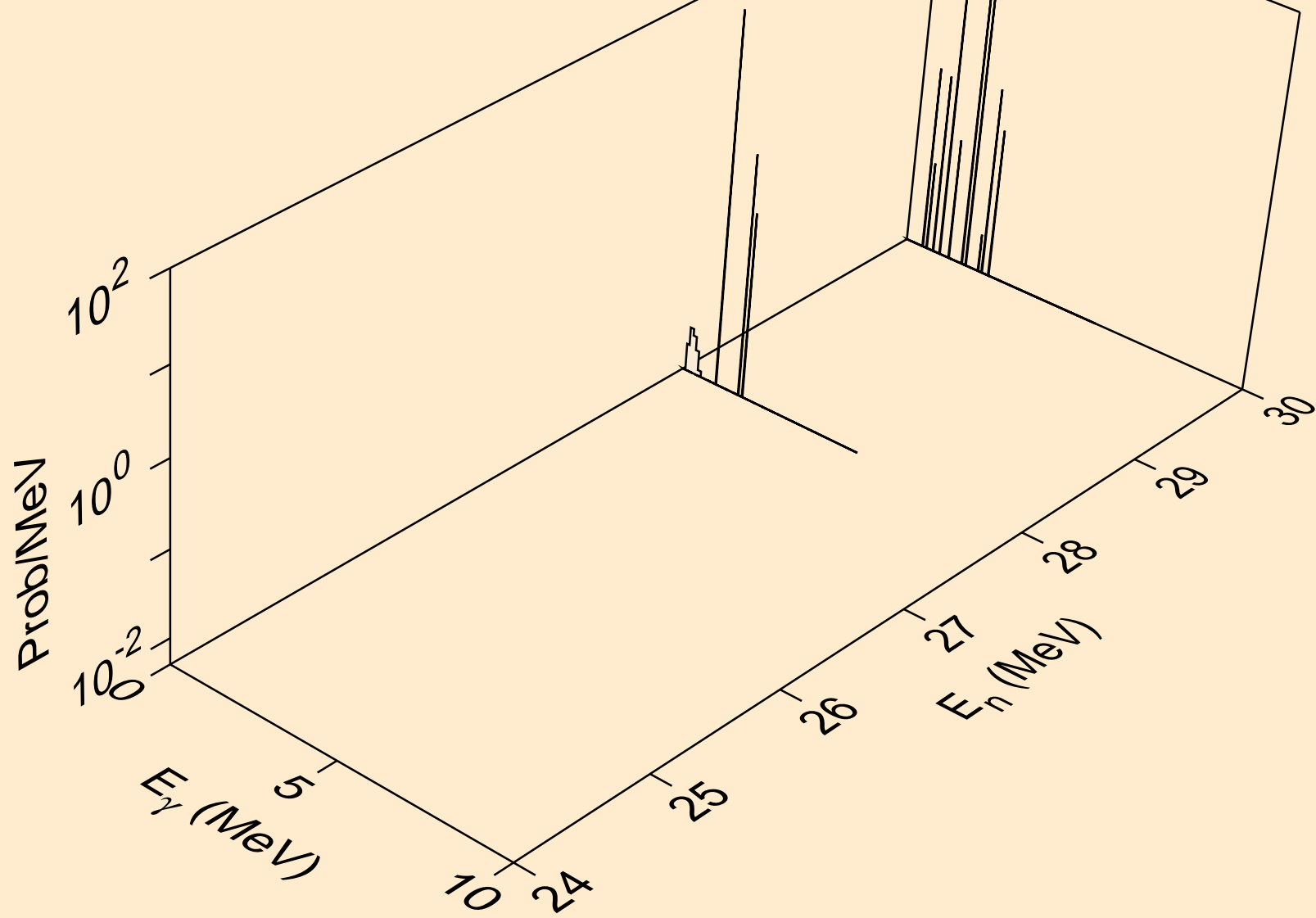

F023 ALPHA ACER TENDL-2024 LIBRARY; T=0.K
Photon emission for (n,npa)

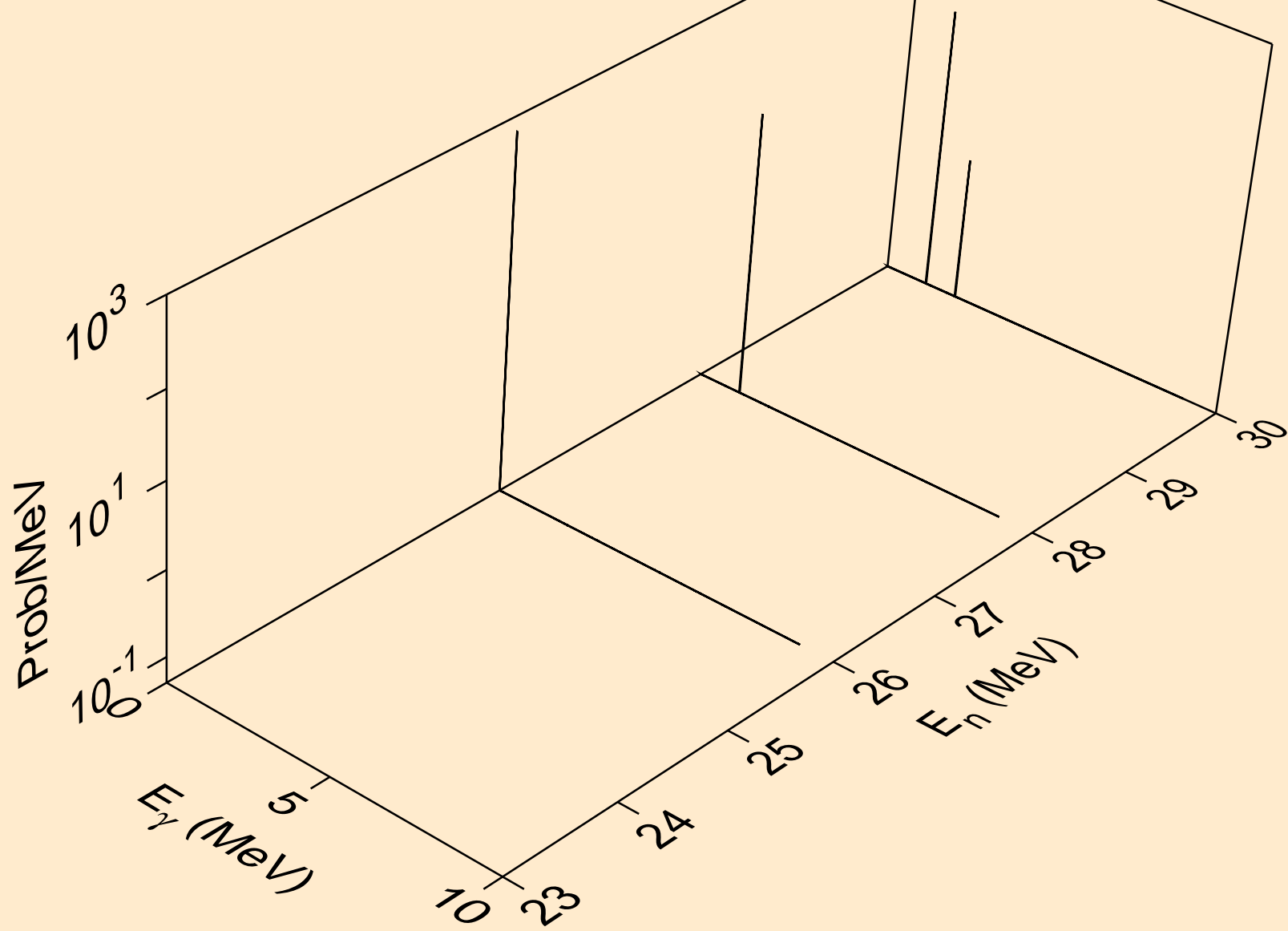

F023 ALPHA ACER TENDL-2024 LIBRARY; T=0.K
Photon emission for (n,gma)

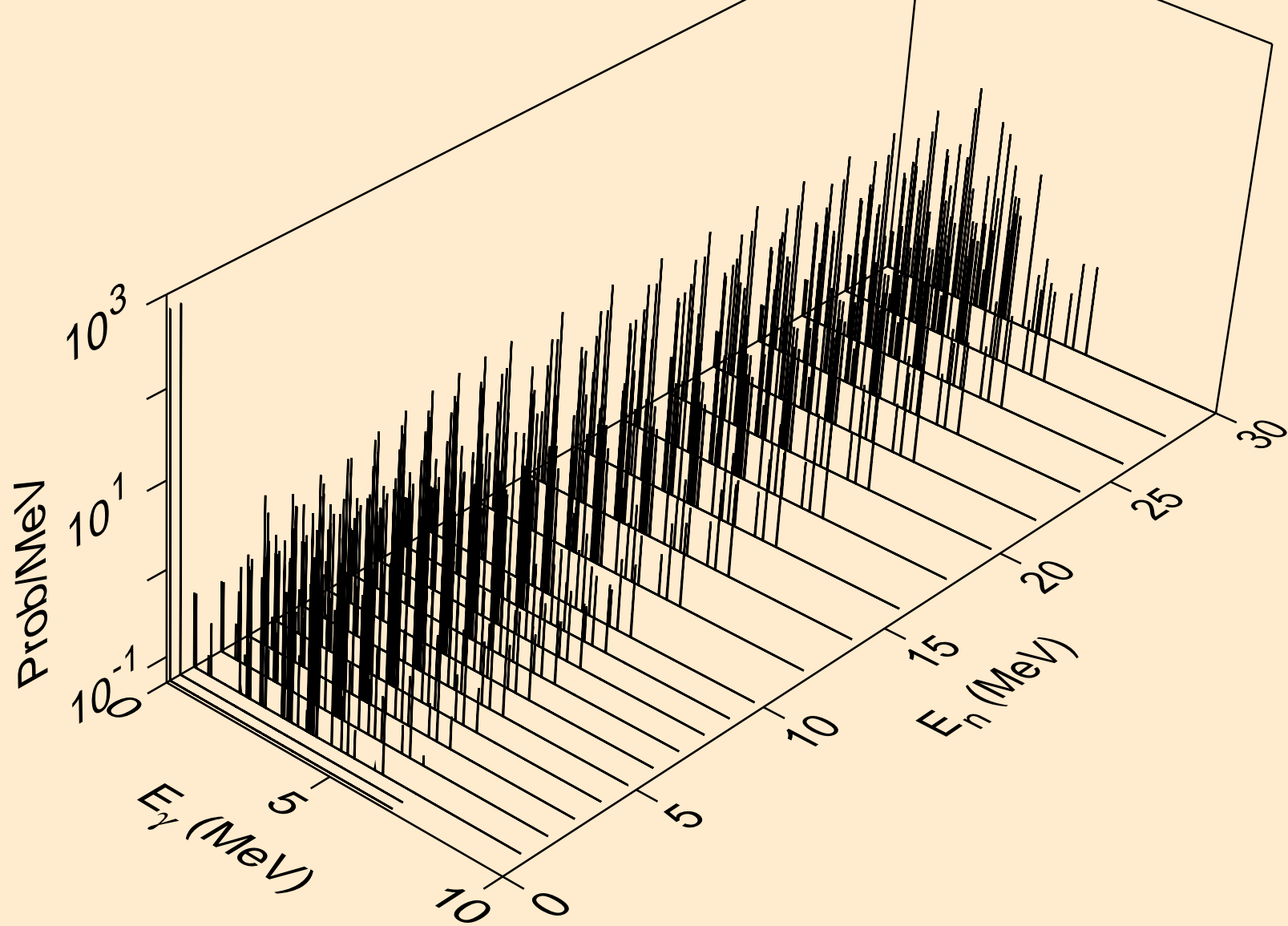

F023 ALPHA ACER TENDL-2024 LIBRARY; T=0.K
Photon emission for (n,p)

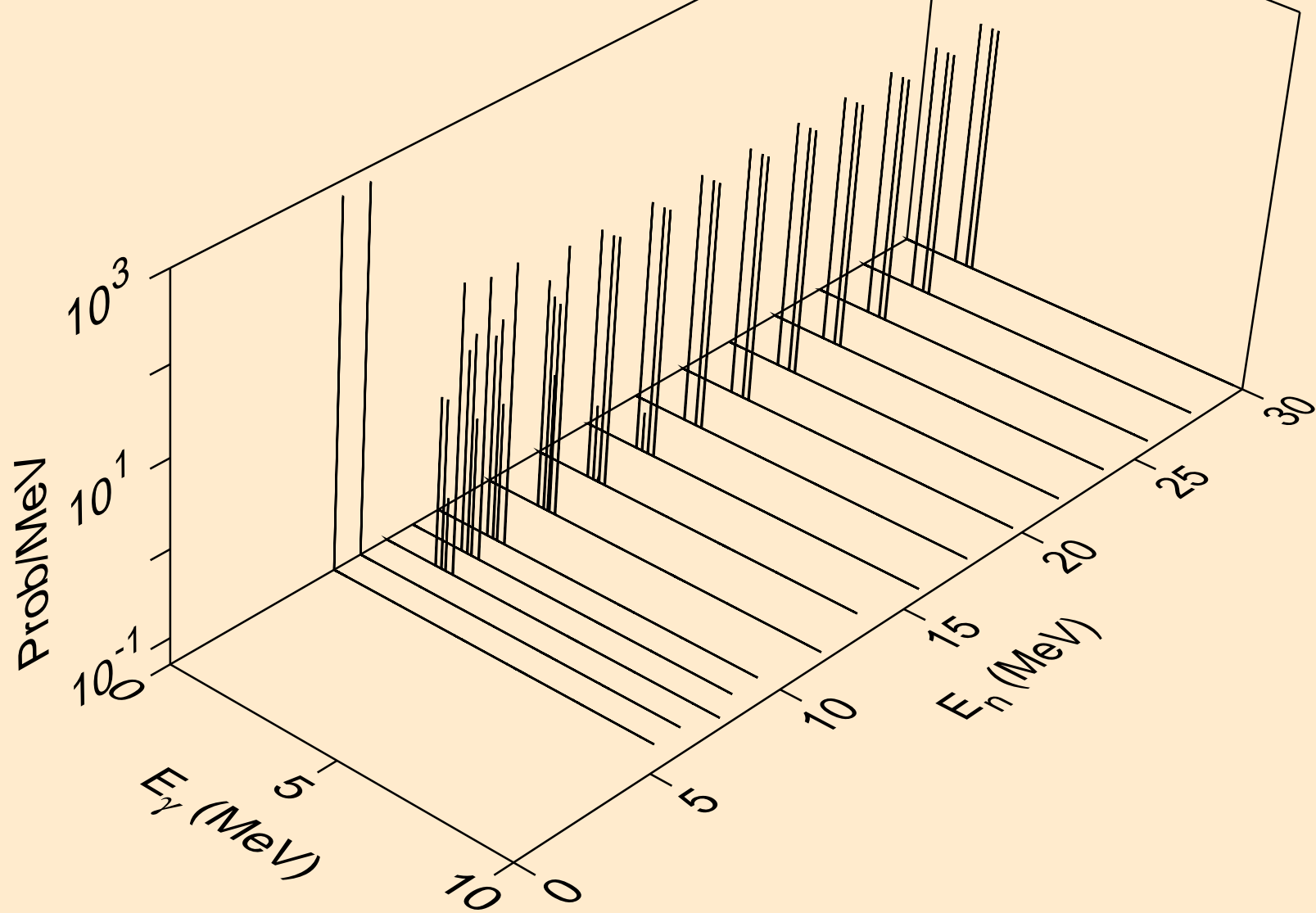

F023 ALPHA ACER TENDL-2024 LIBRARY; T=0.K
Photon emission for (n,d)

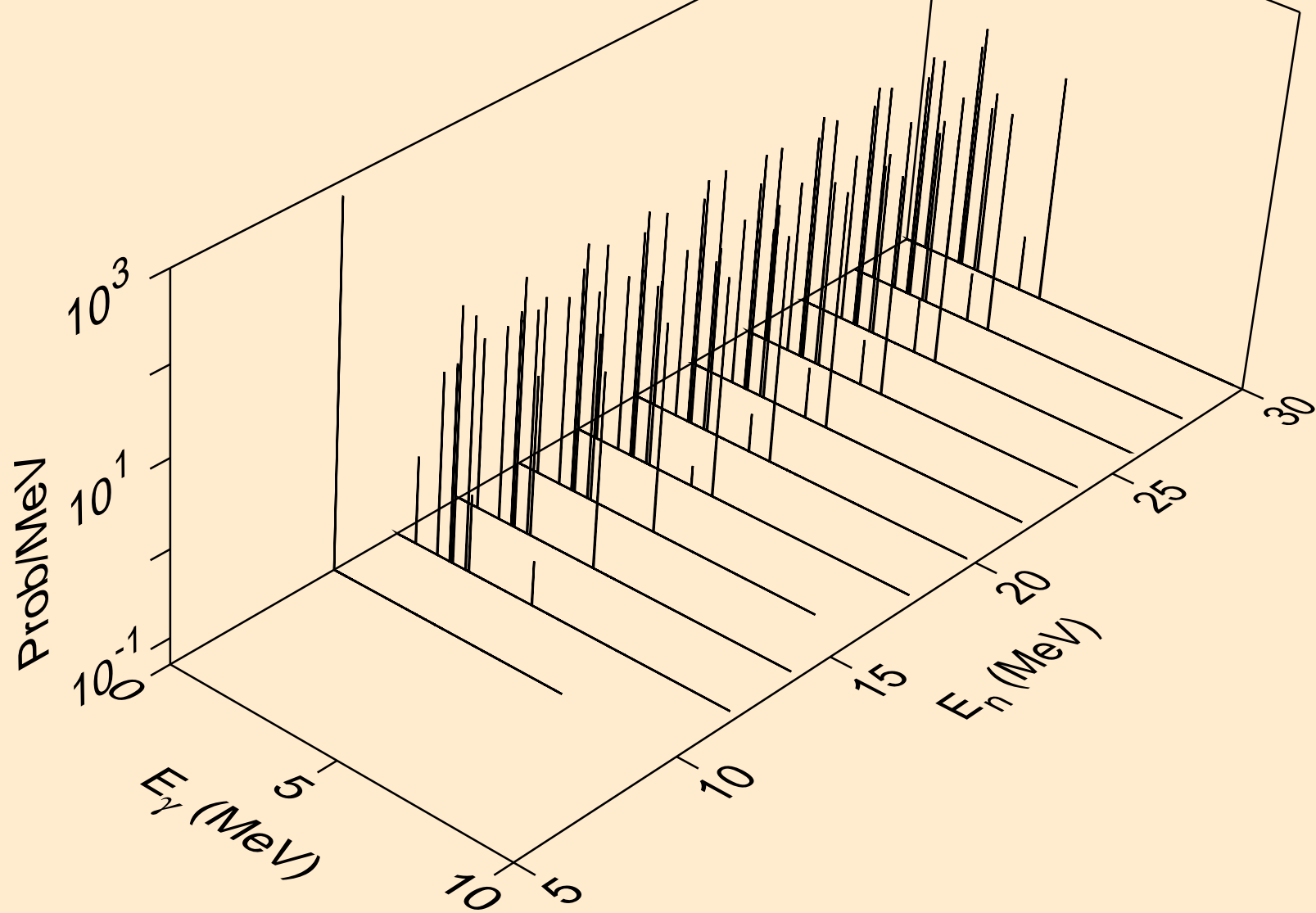

F023 ALPHA ACER TENDL-2024 LIBRARY; T=0.K
Photon emission for (n,t)

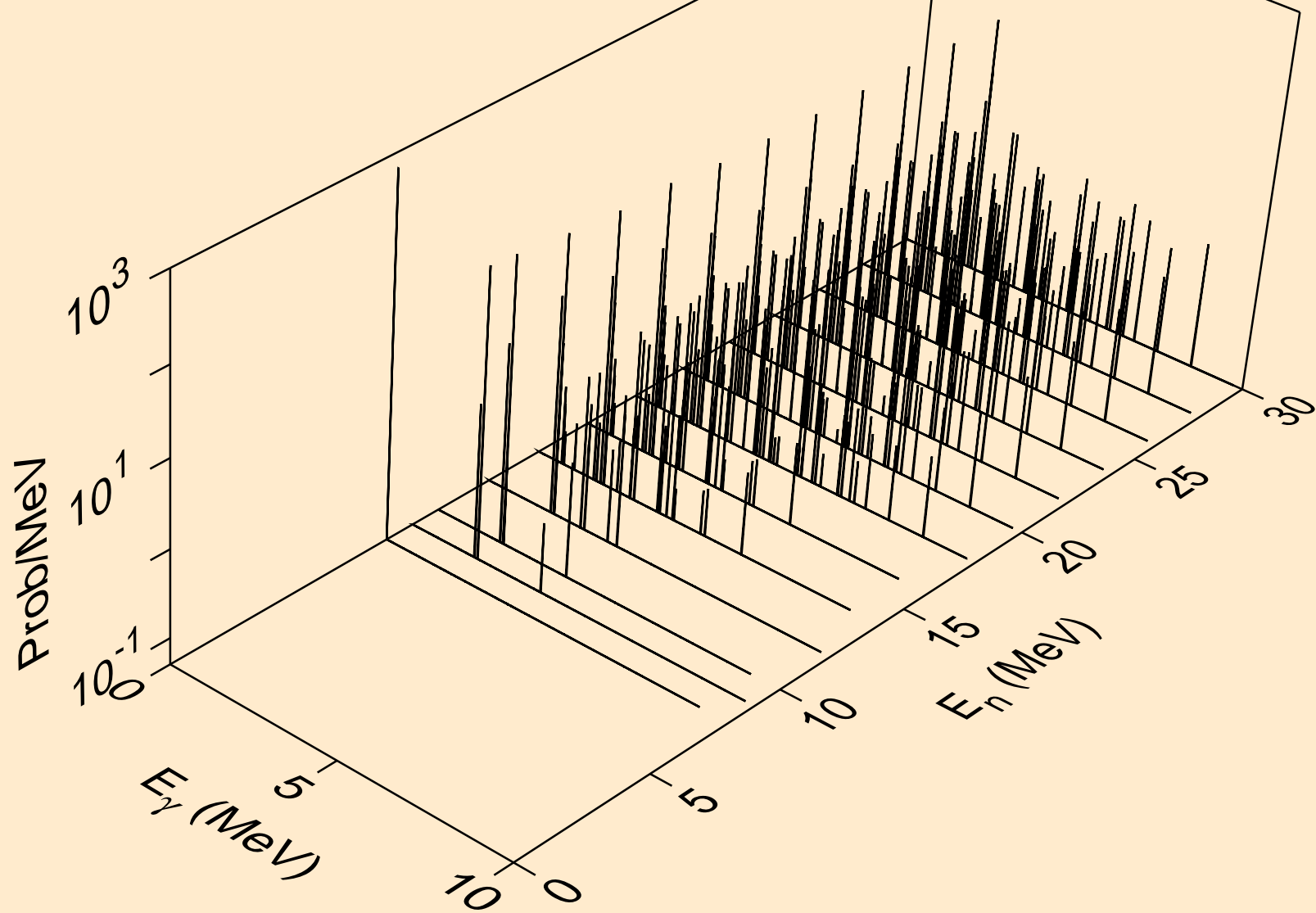

F023 ALPHA ACER TENDL-2024 LIBRARY; T=0.K
Photon emission for (n,he3)

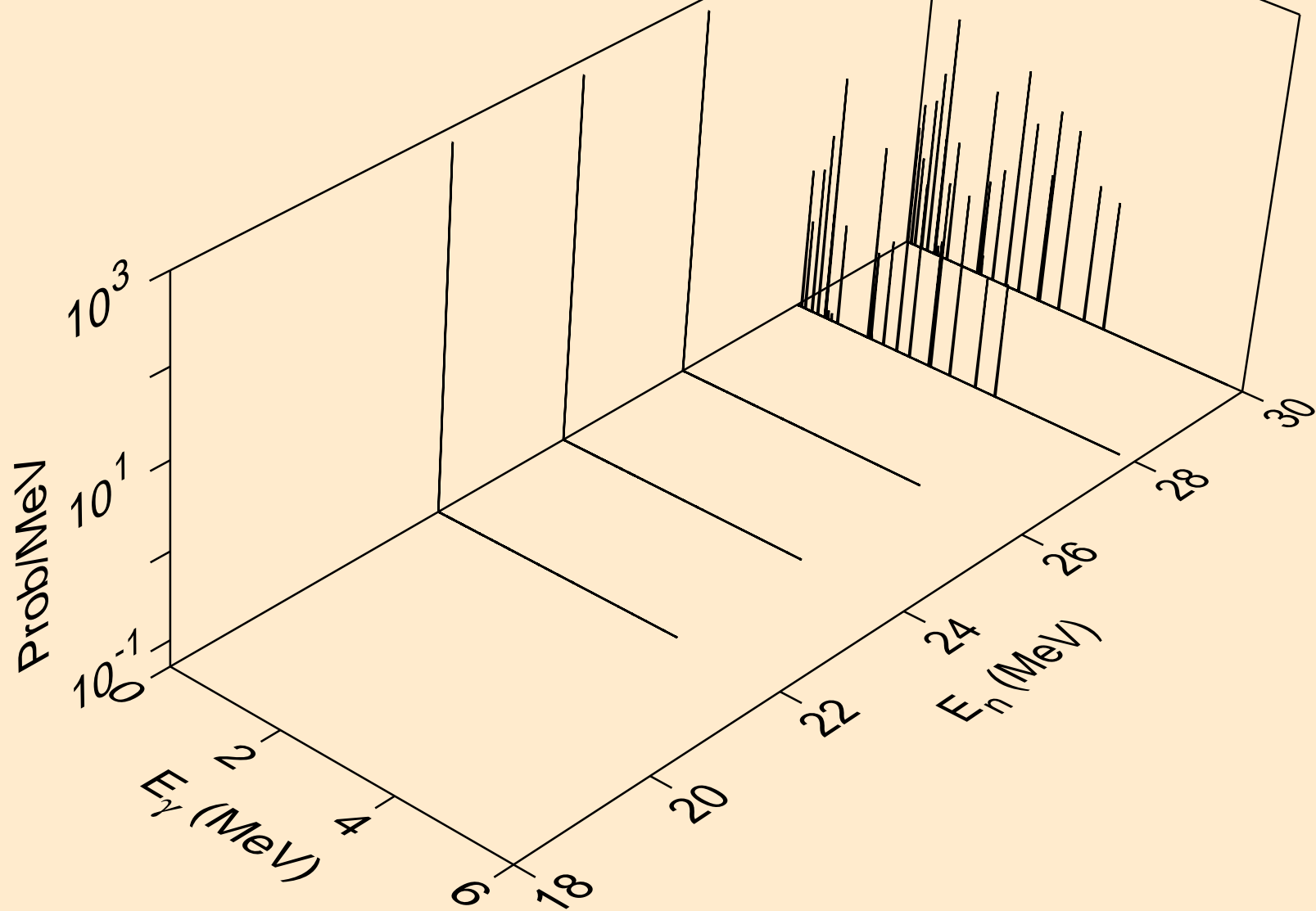

F023 ALPHA ACER TENDL-2024 LIBRARY; T=0.K
Photon emission for inelastic

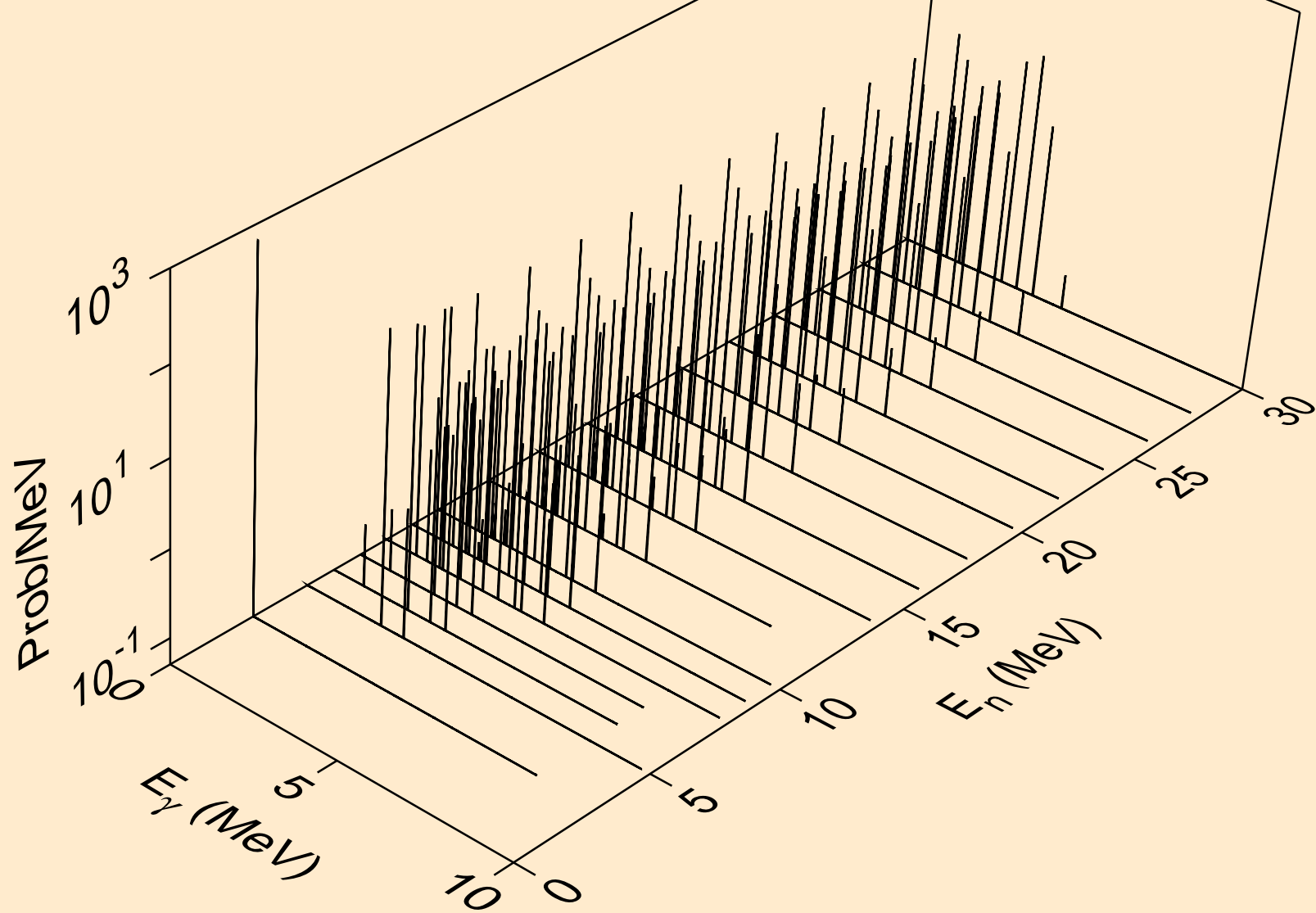

F023 ALPHA ACER TENDL-2024 LIBRARY; T=0.K
Photon emission for (n,2a)

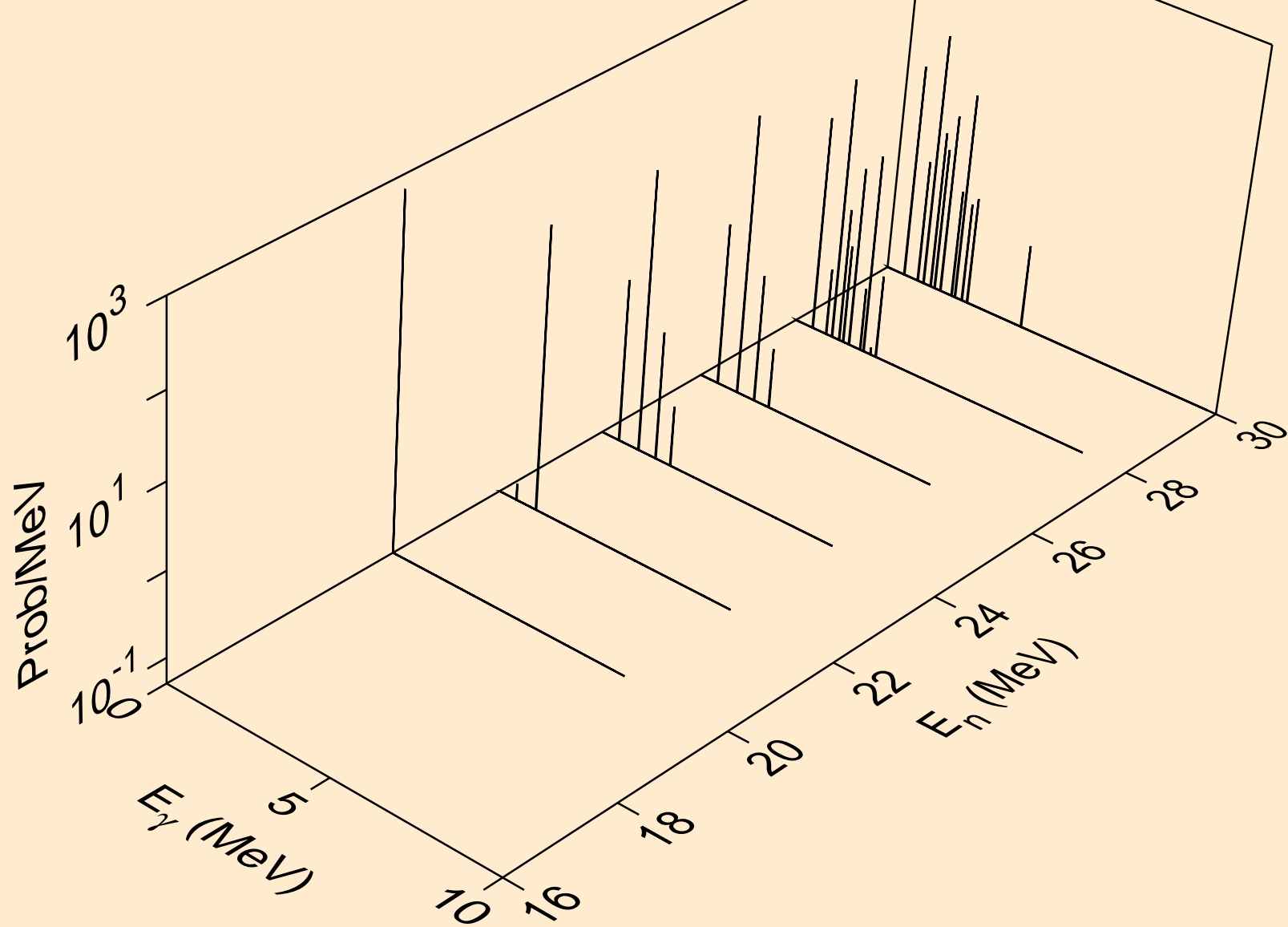

F023 ALPHA ACER TENDL-2024 LIBRARY; T=0.K
Photon emission for (n,2p)

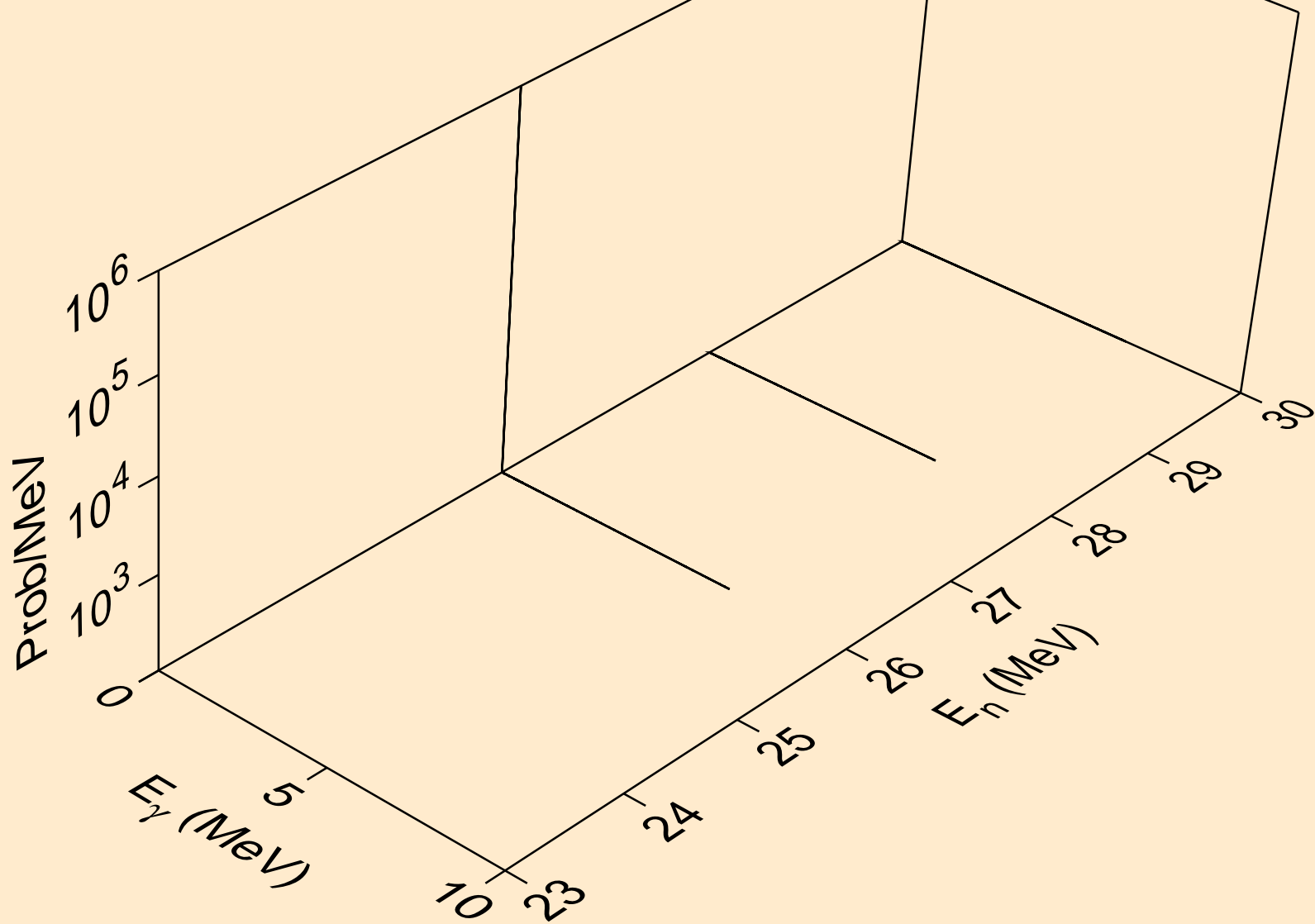

F023 ALPHA ACER TENDL-2024 LIBRARY; T=0.K
Photon emission for (n,pa)

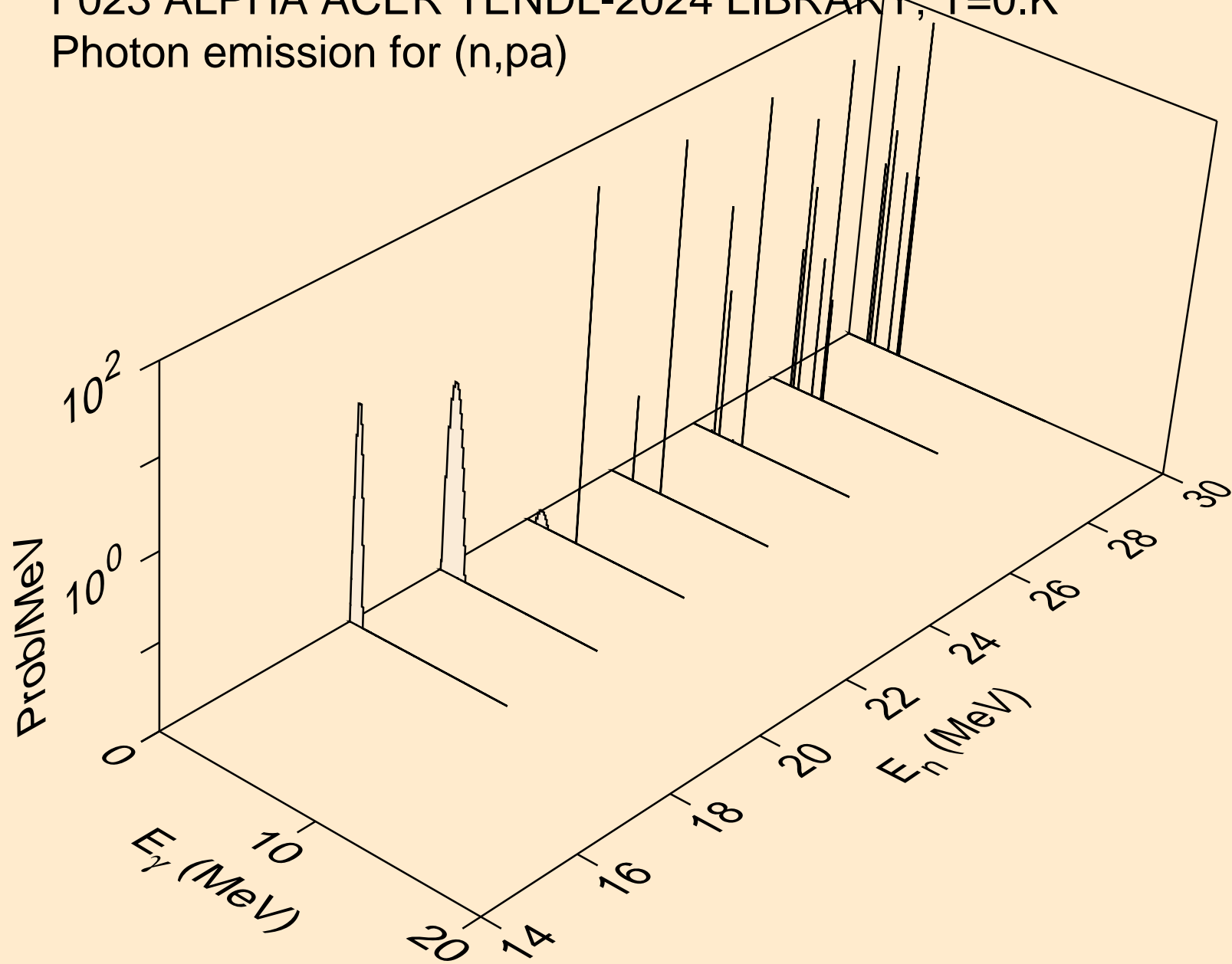

F023 ALPHA ACER TENDL-2024 LIBRARY; T=0.K
Photon emission for (n,pd)

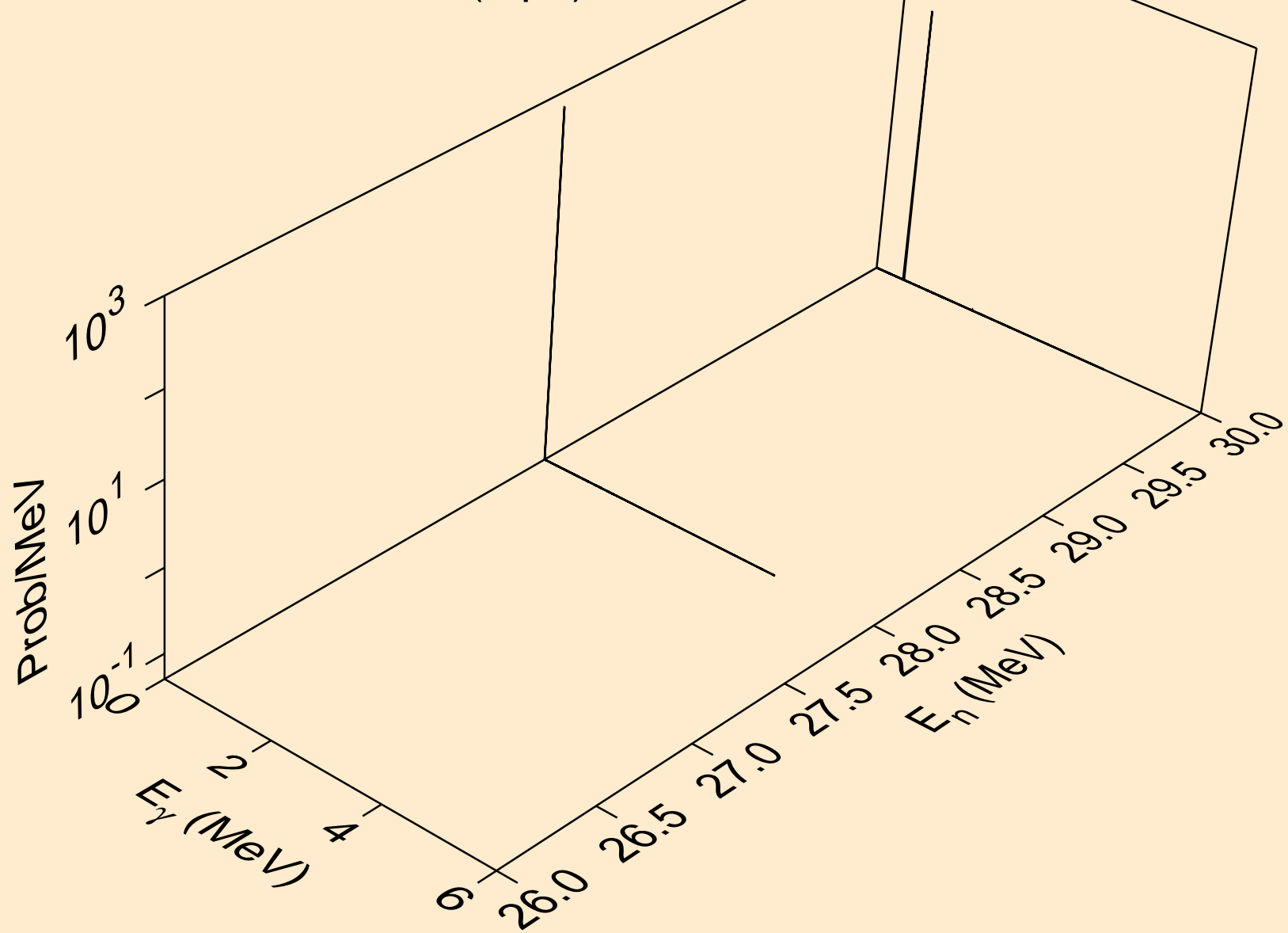

F023 ALPHA ACER TENDL-2024 LIBRARY; T=0.K
Photon emission for (n,pt)

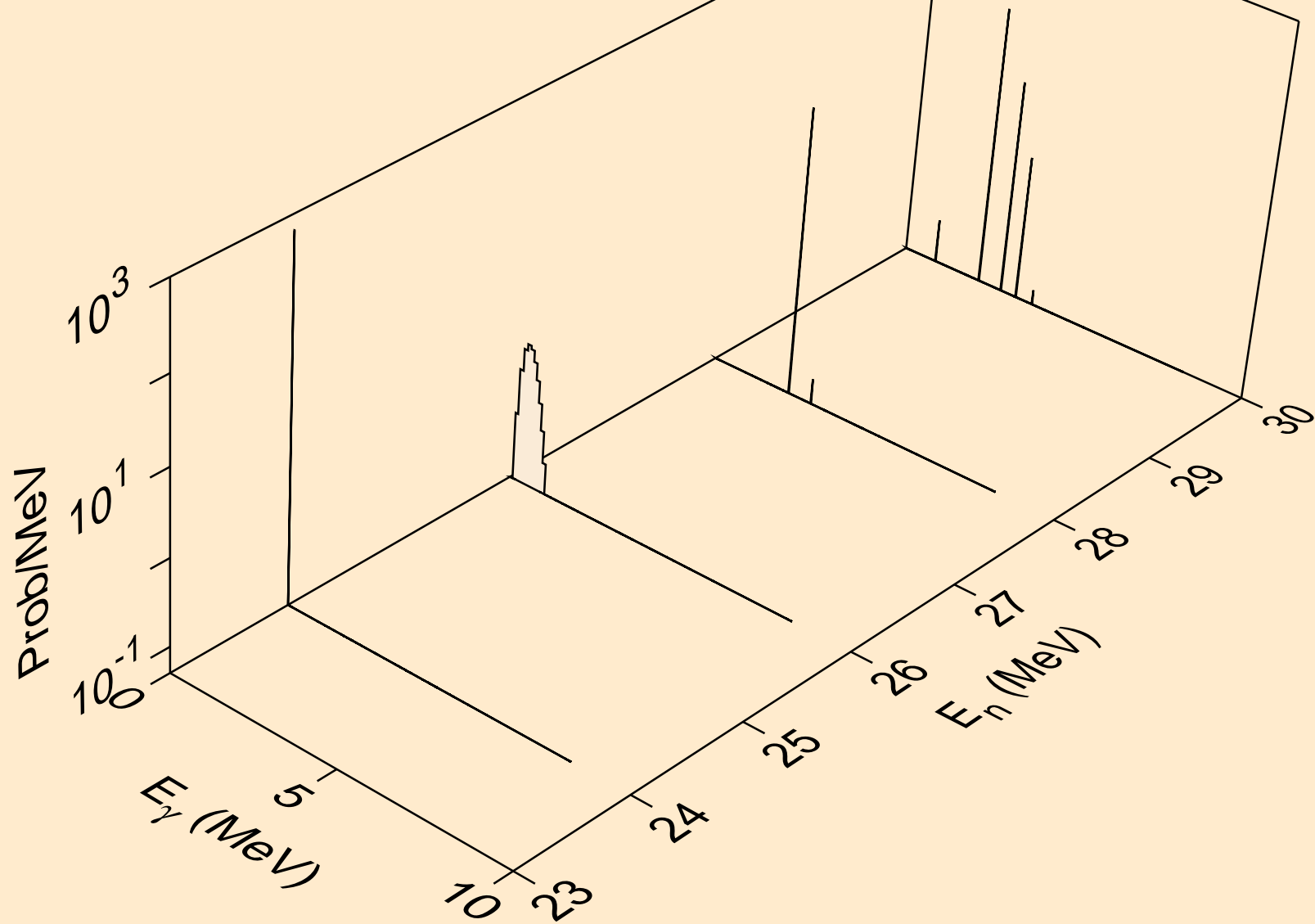

F023 ALPHA ACER TENDL-2024 LIBRARY; T=0.K
Photon emission for (n,da)

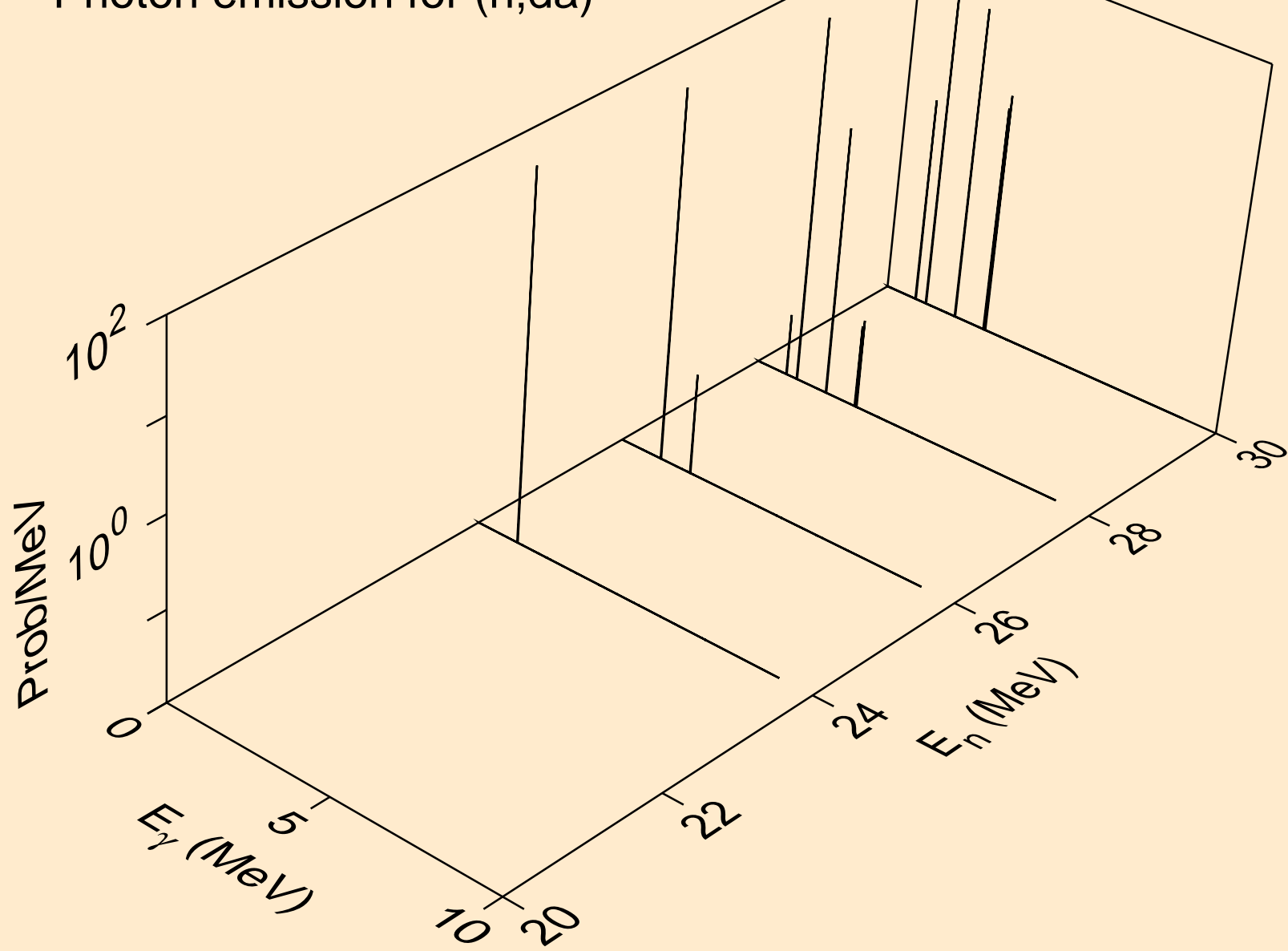

F023 ALPHA ACER TENDL-2024 LIBRARY; T=0.K
Particle heating contributions

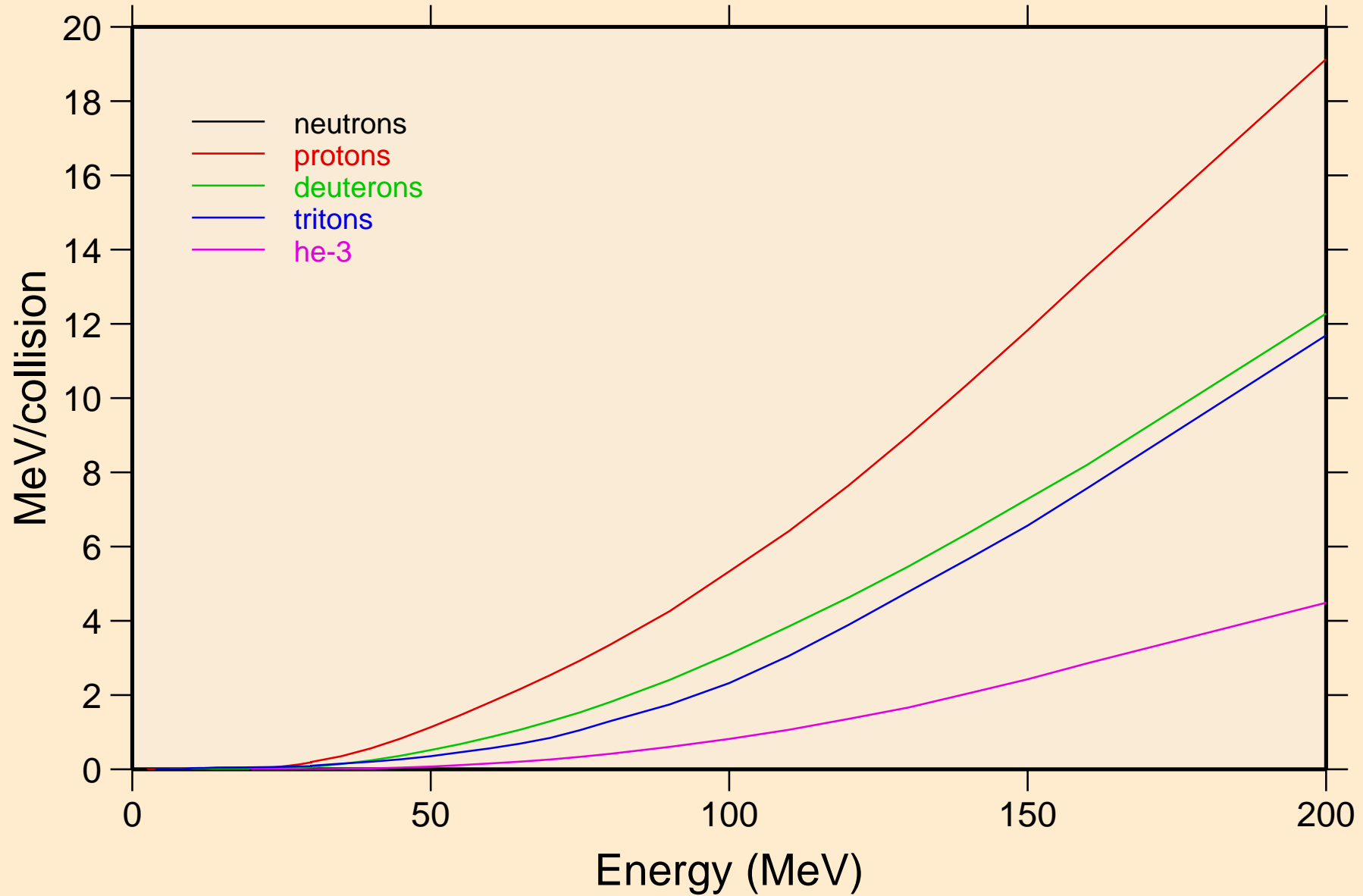

F023 ALPHA ACER TENDL-2024 LIBRARY; T=0.K
Recoil Heating

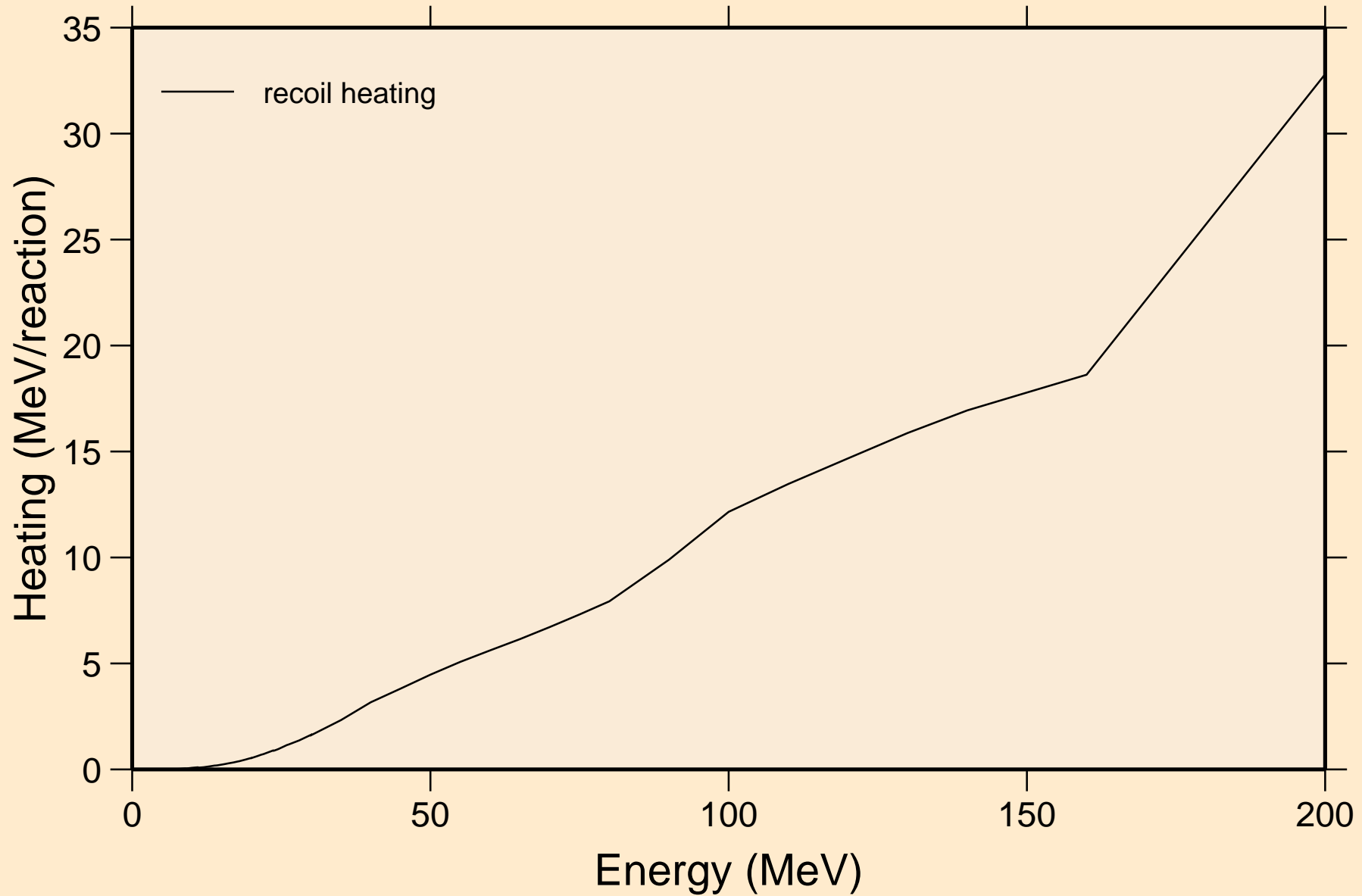

F023 ALPHA ACER TENDL-2024 LIBRARY; T=0.K
Particle production cross sections

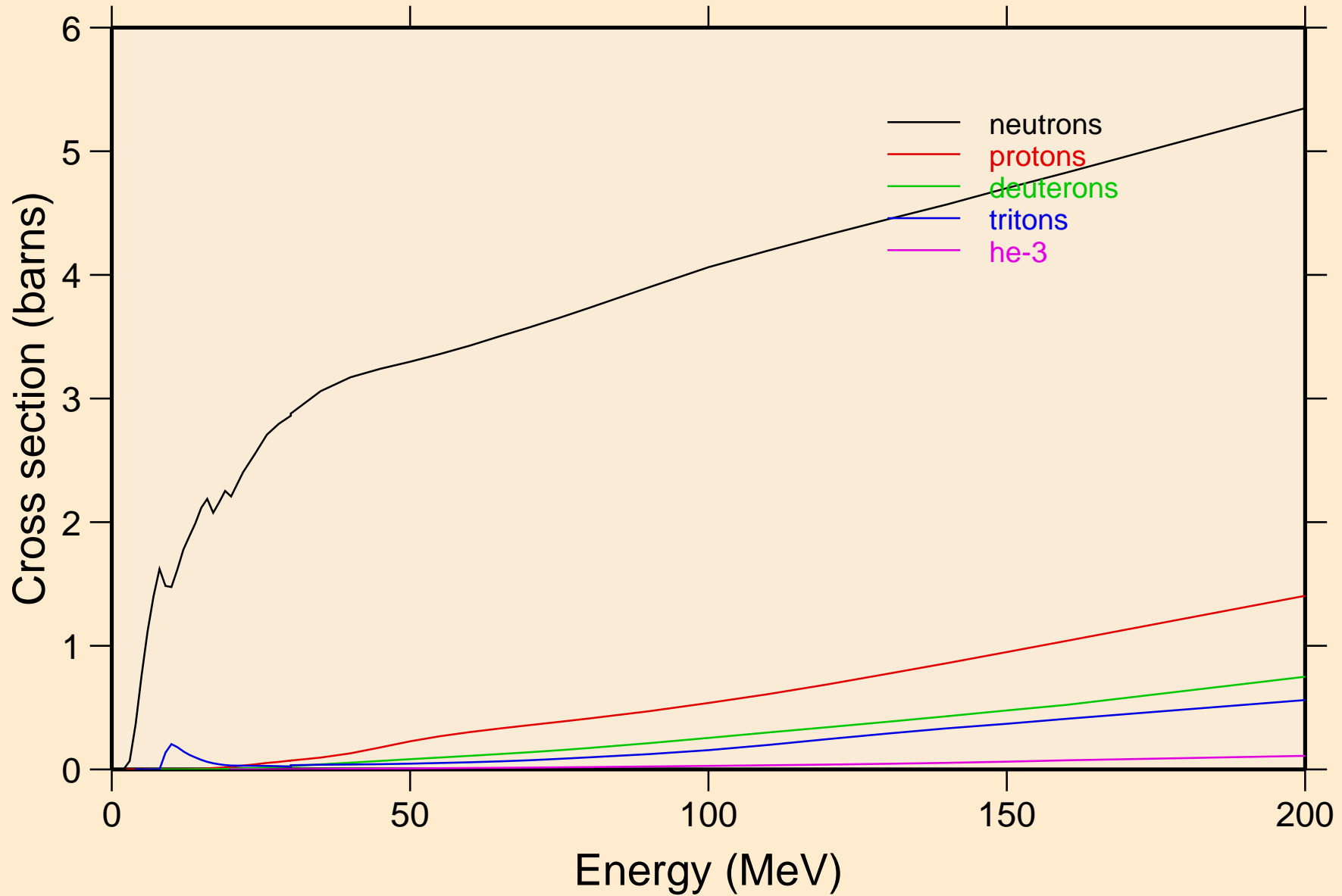

F023 ALPHA ACER TENDL-2024 LIBRARY; T=0.K
neutrons from (a,n)

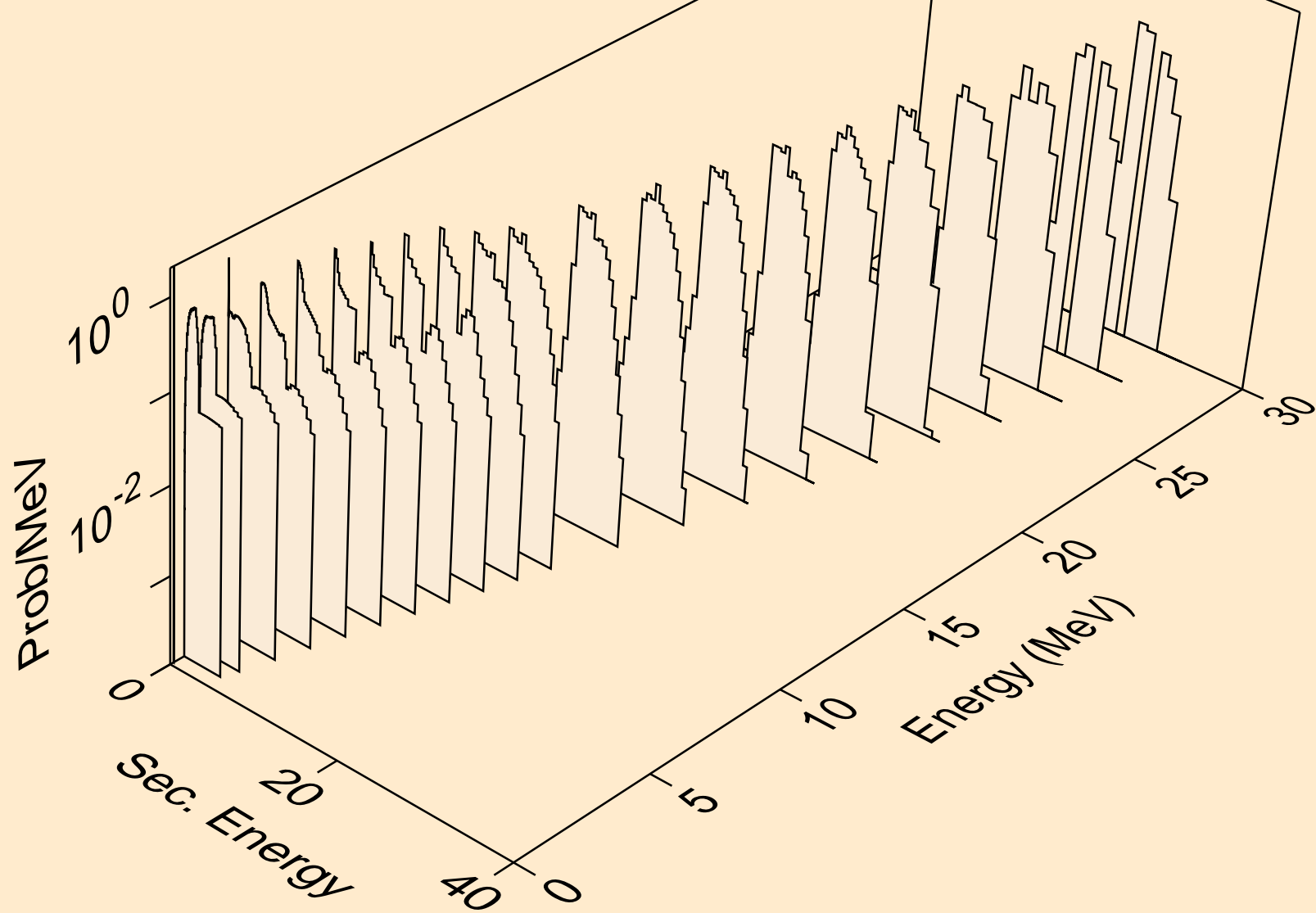

F023 ALPHA ACER TENDL-2024 LIBRARY; T=0.K
neutrons from (a,x)

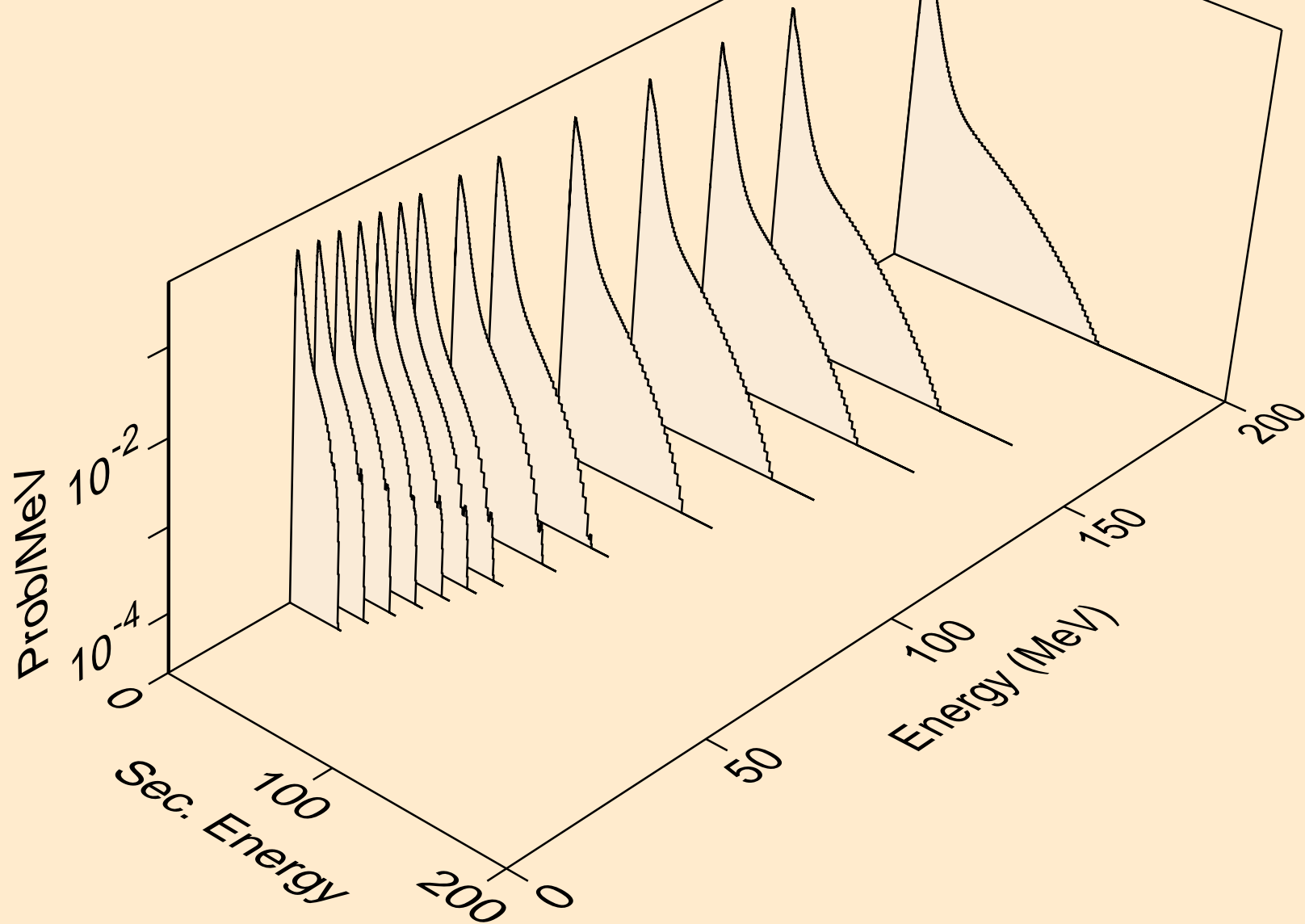

F023 ALPHA ACER TENDL-2024 LIBRARY; T=0.K
neutrons from (a,2nd)

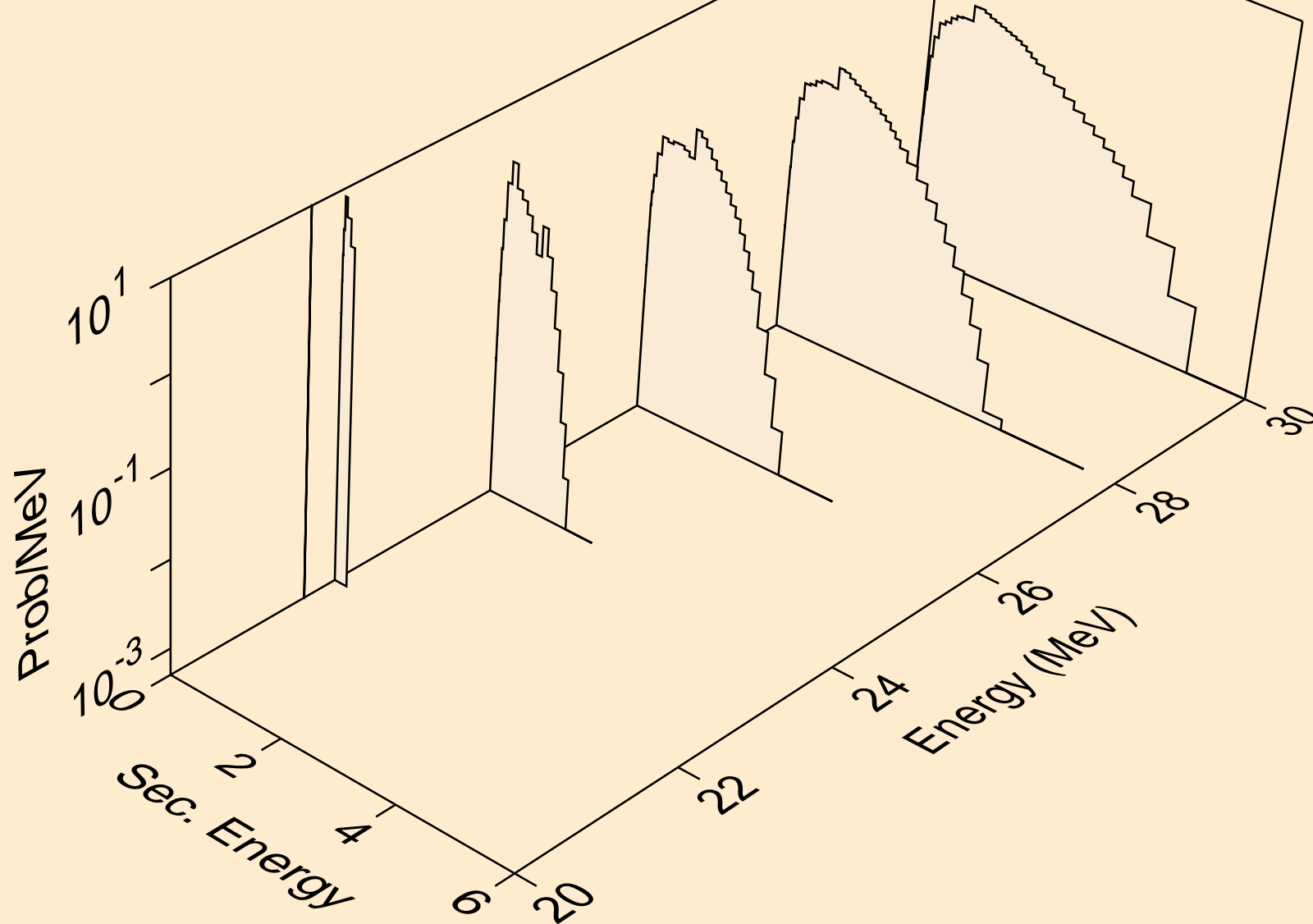

F023 ALPHA ACER TENDL-2024 LIBRARY; T=0.K
neutrons from (a,2n)

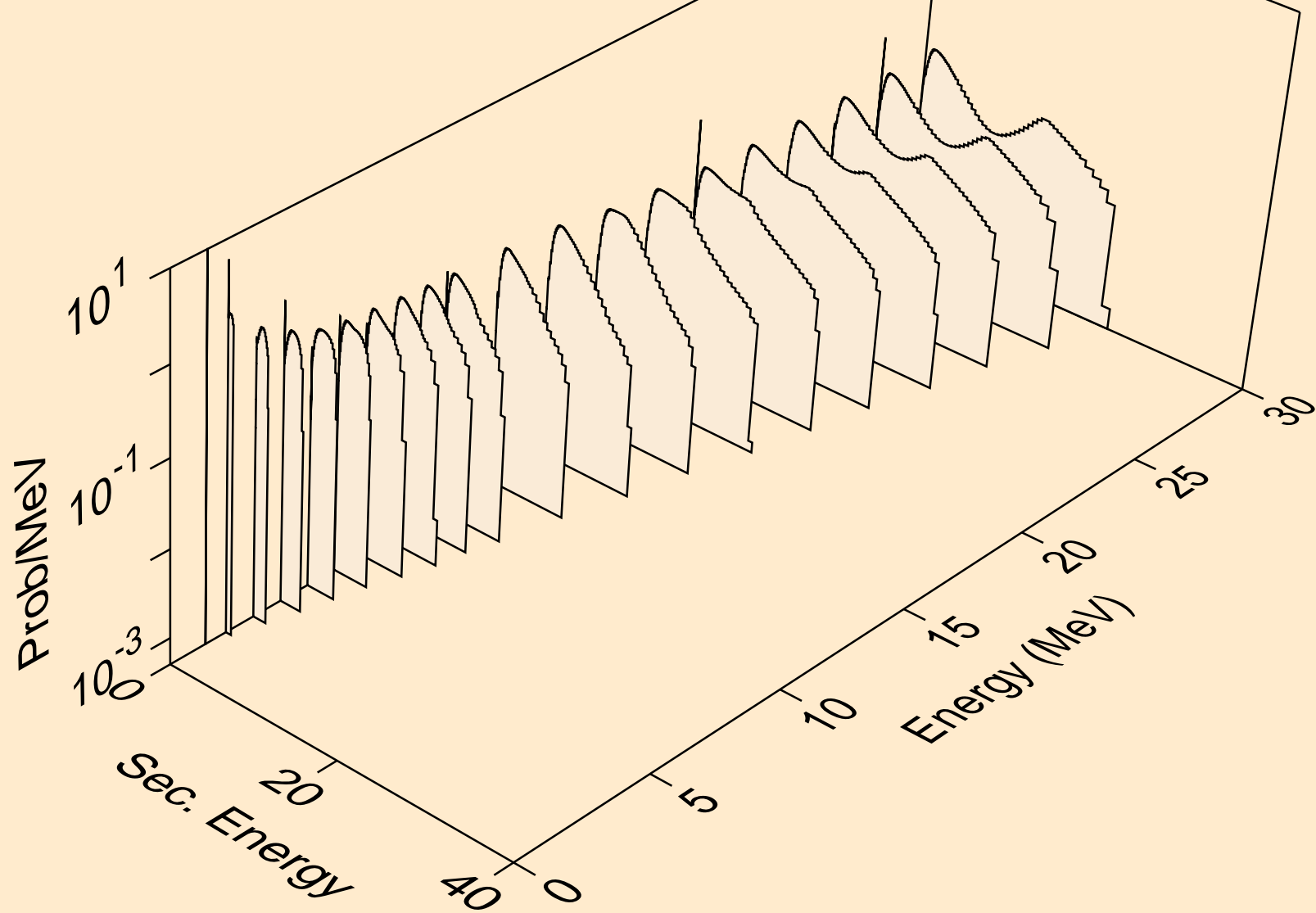

F023 ALPHA ACER TENDL-2024 LIBRARY; T=0.K
neutrons from (a,3n)

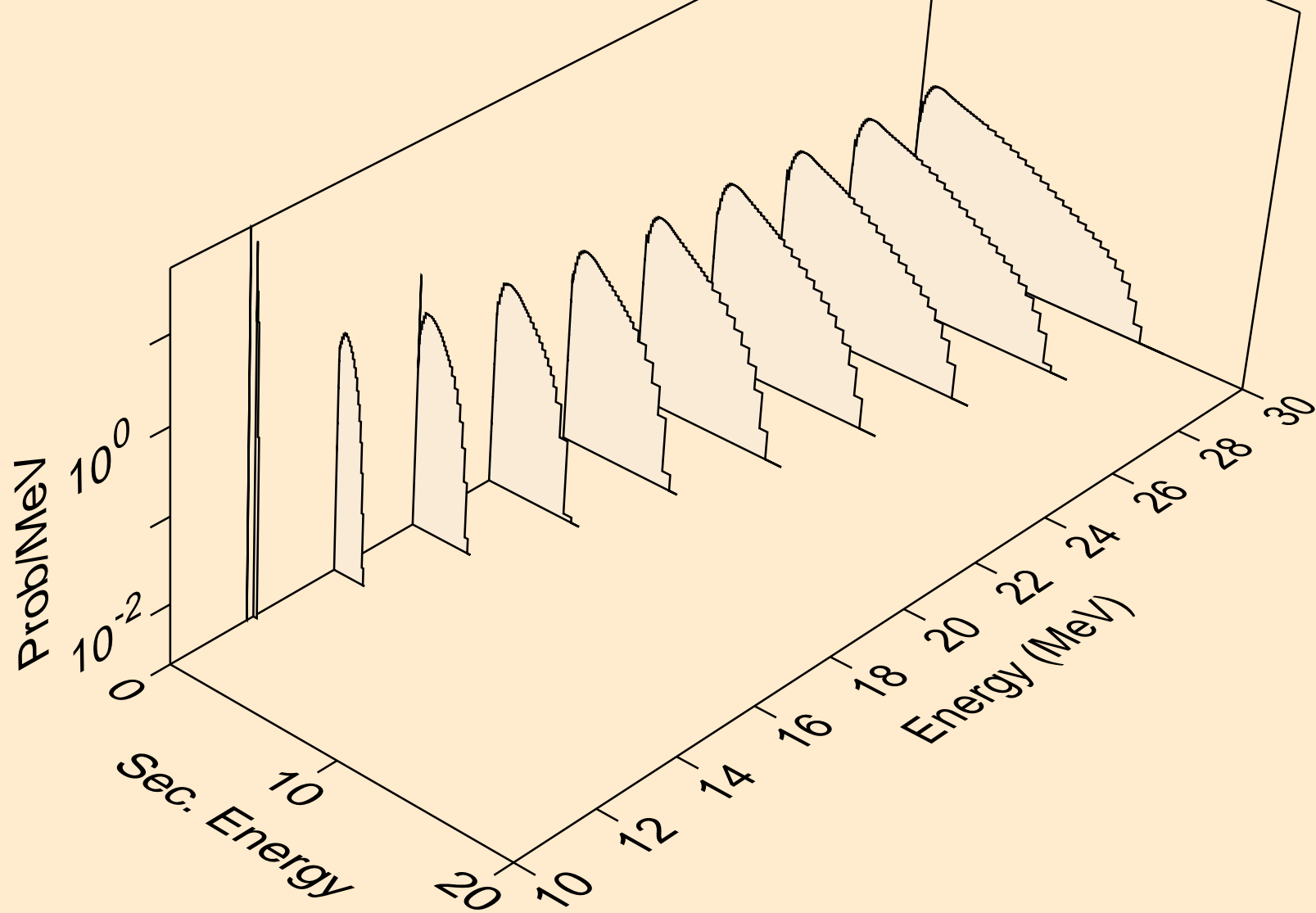

F023 ALPHA ACER TENDL-2024 LIBRARY; T=0.K
neutrons from (a,n*)a

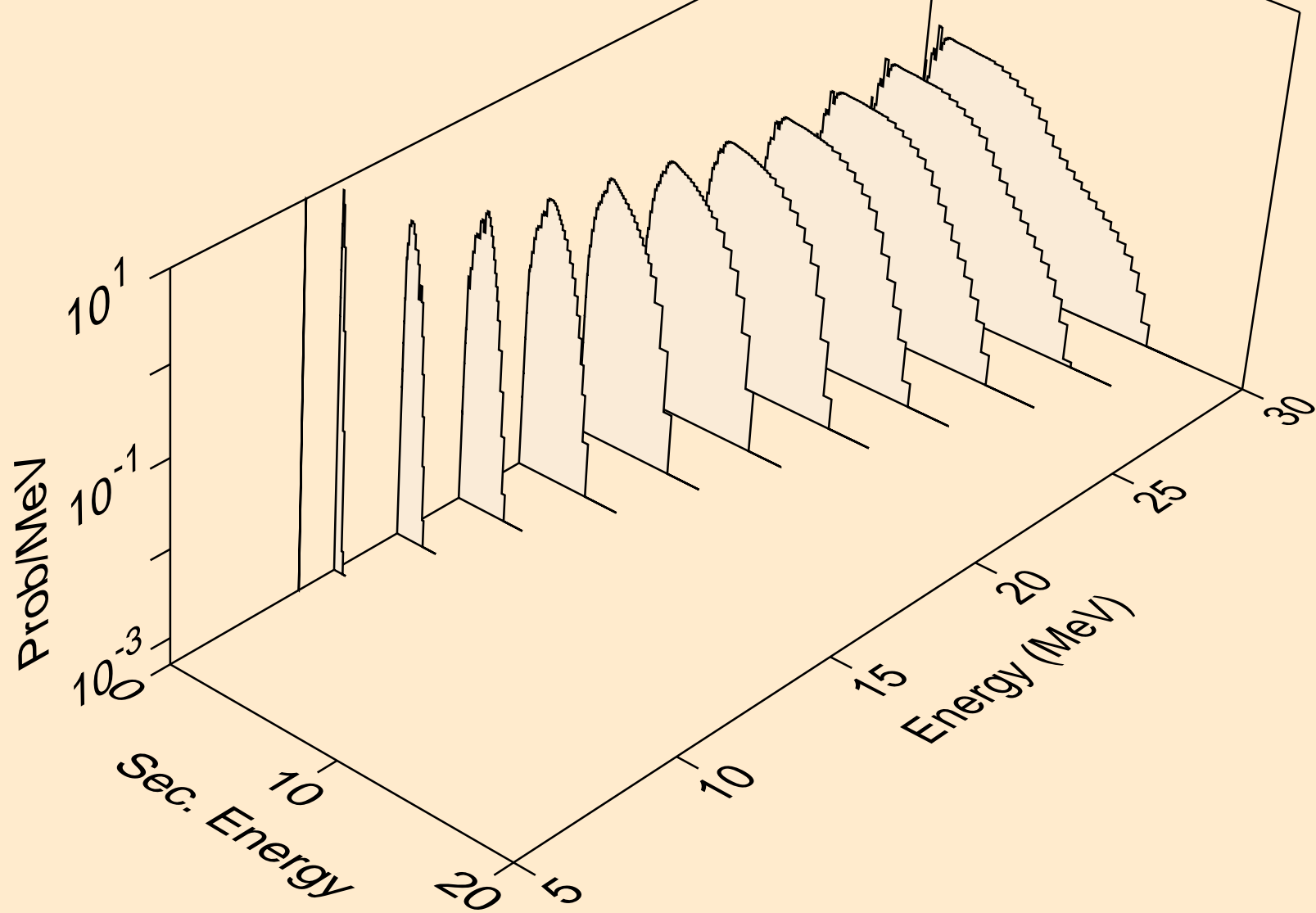

F023 ALPHA ACER TENDL-2024 LIBRARY; T=0.K
neutrons from (a,2n)a

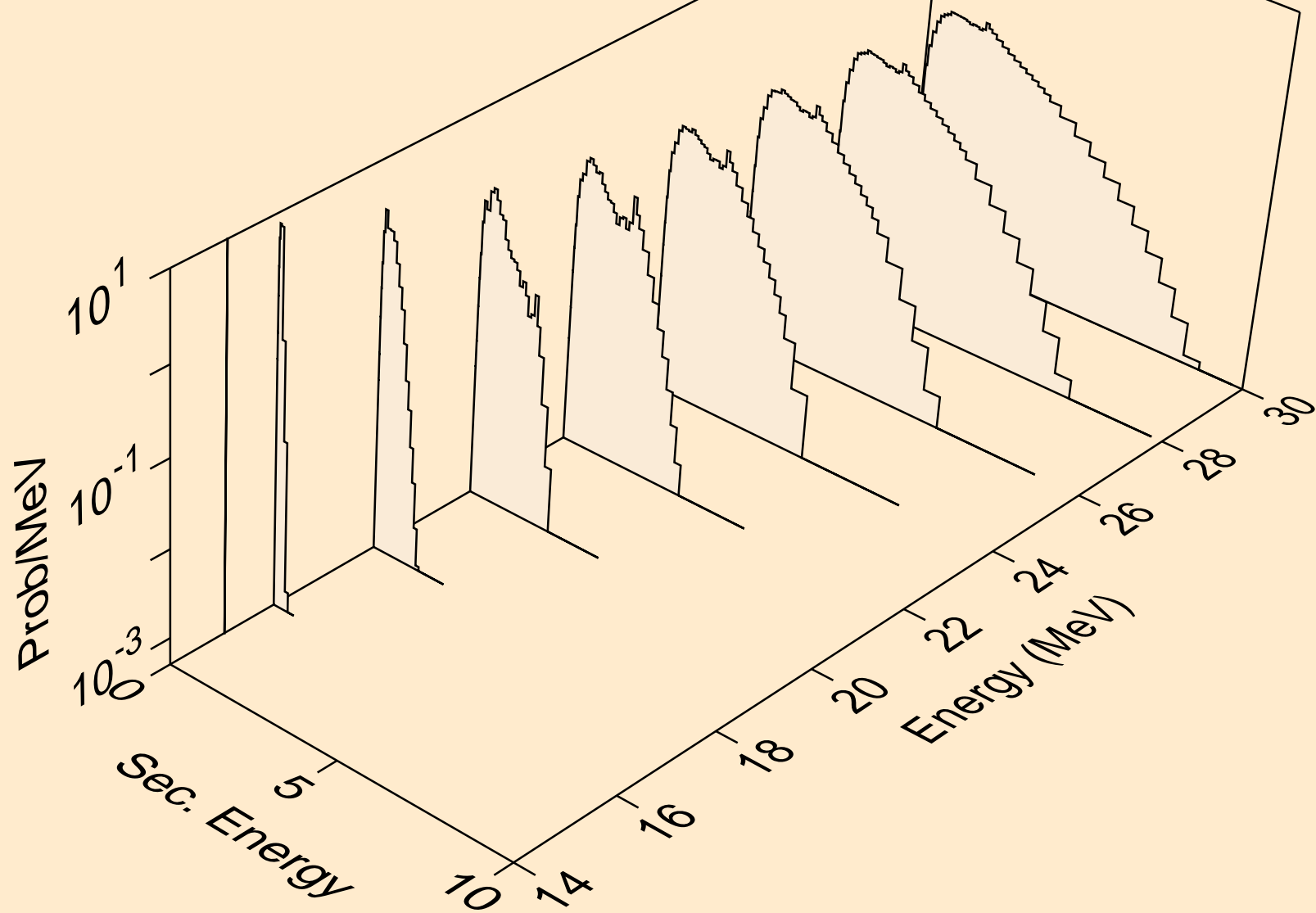

F023 ALPHA ACER TENDL-2024 LIBRARY; T=0.K
neutrons from (a,3n)a

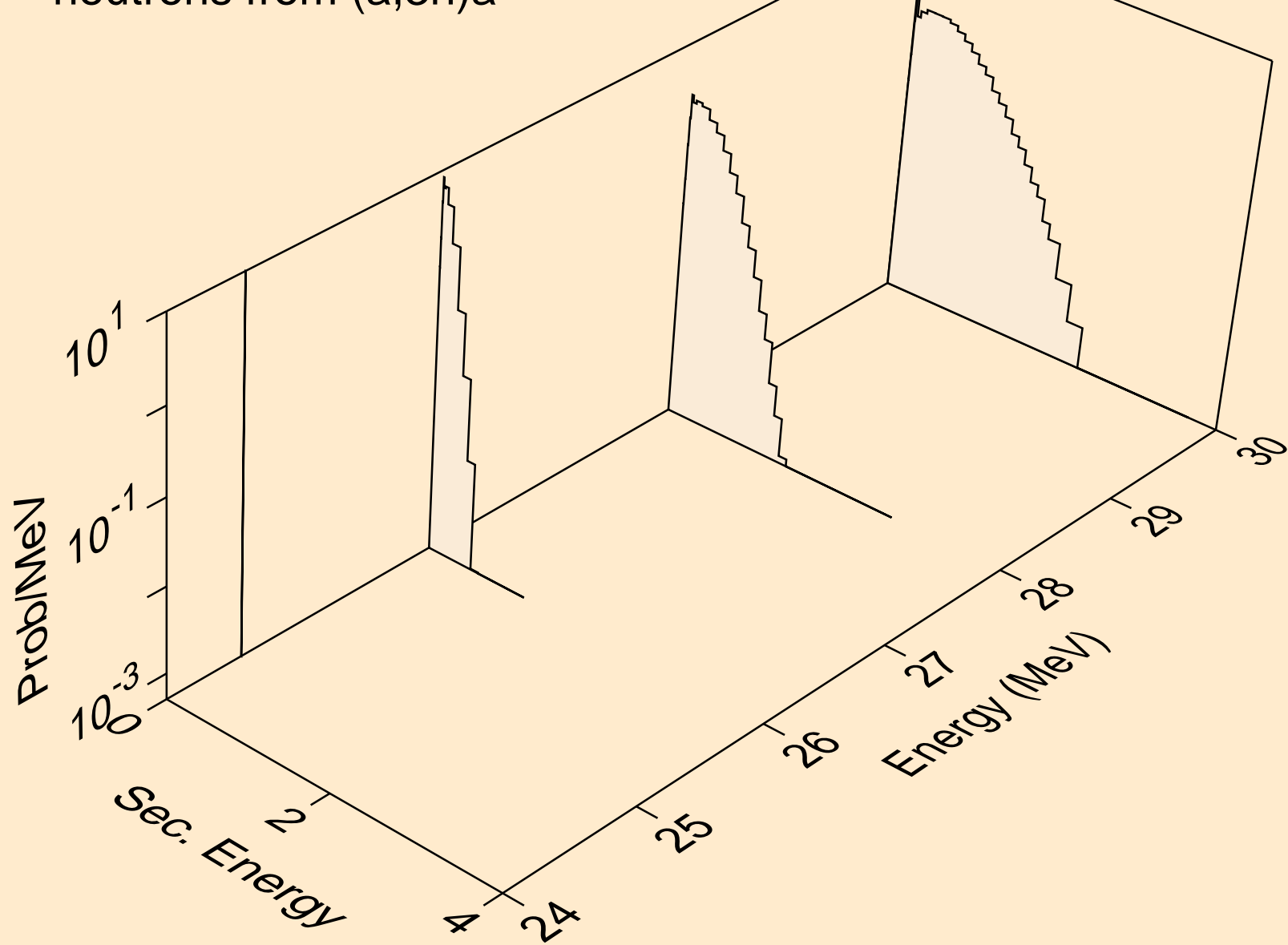

F023 ALPHA ACER TENDL-2024 LIBRARY; T=0.K
neutrons from (a,n*)p

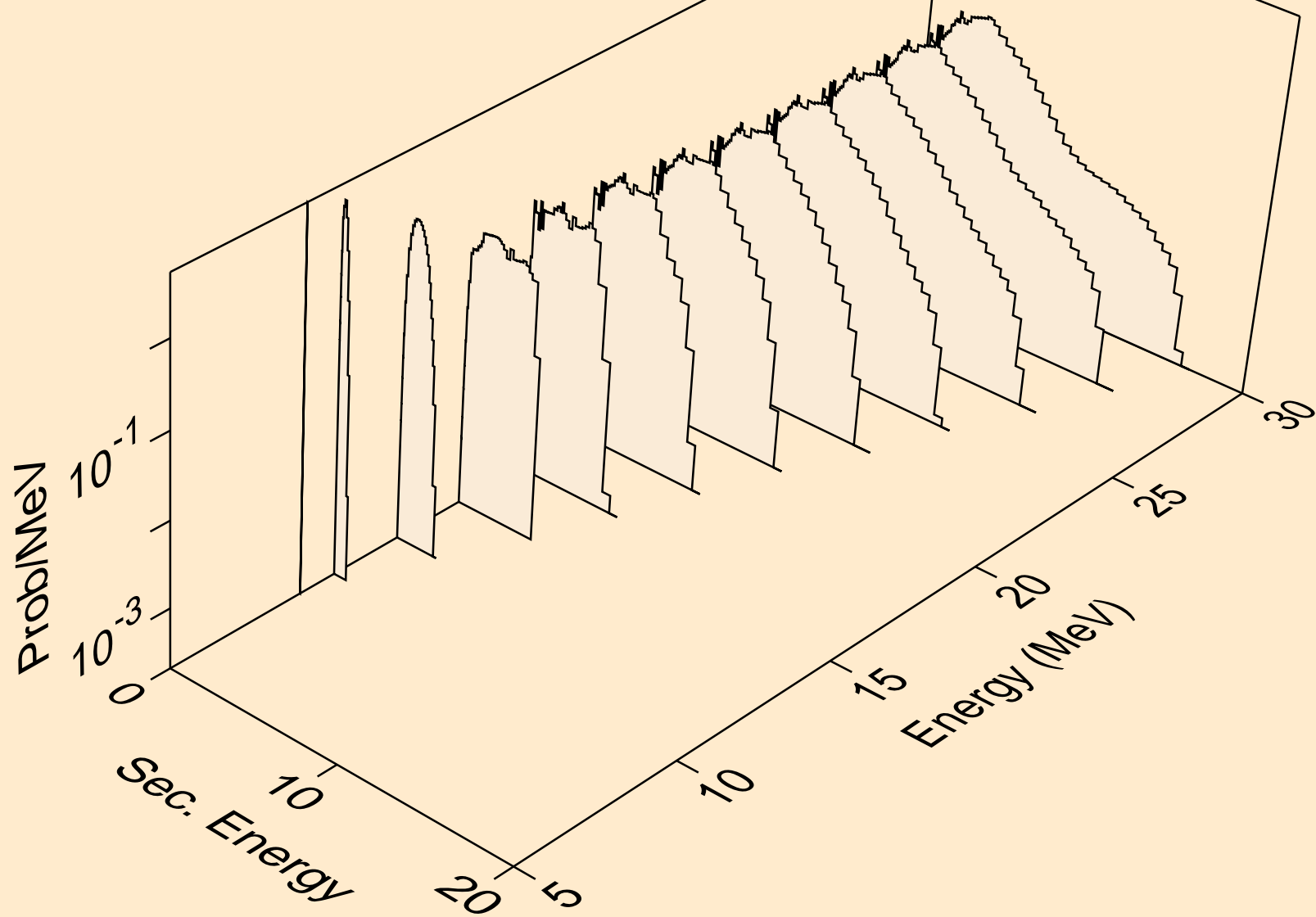

F023 ALPHA ACER TENDL-2024 LIBRARY; T=0.K
neutrons from (a,n*)2a

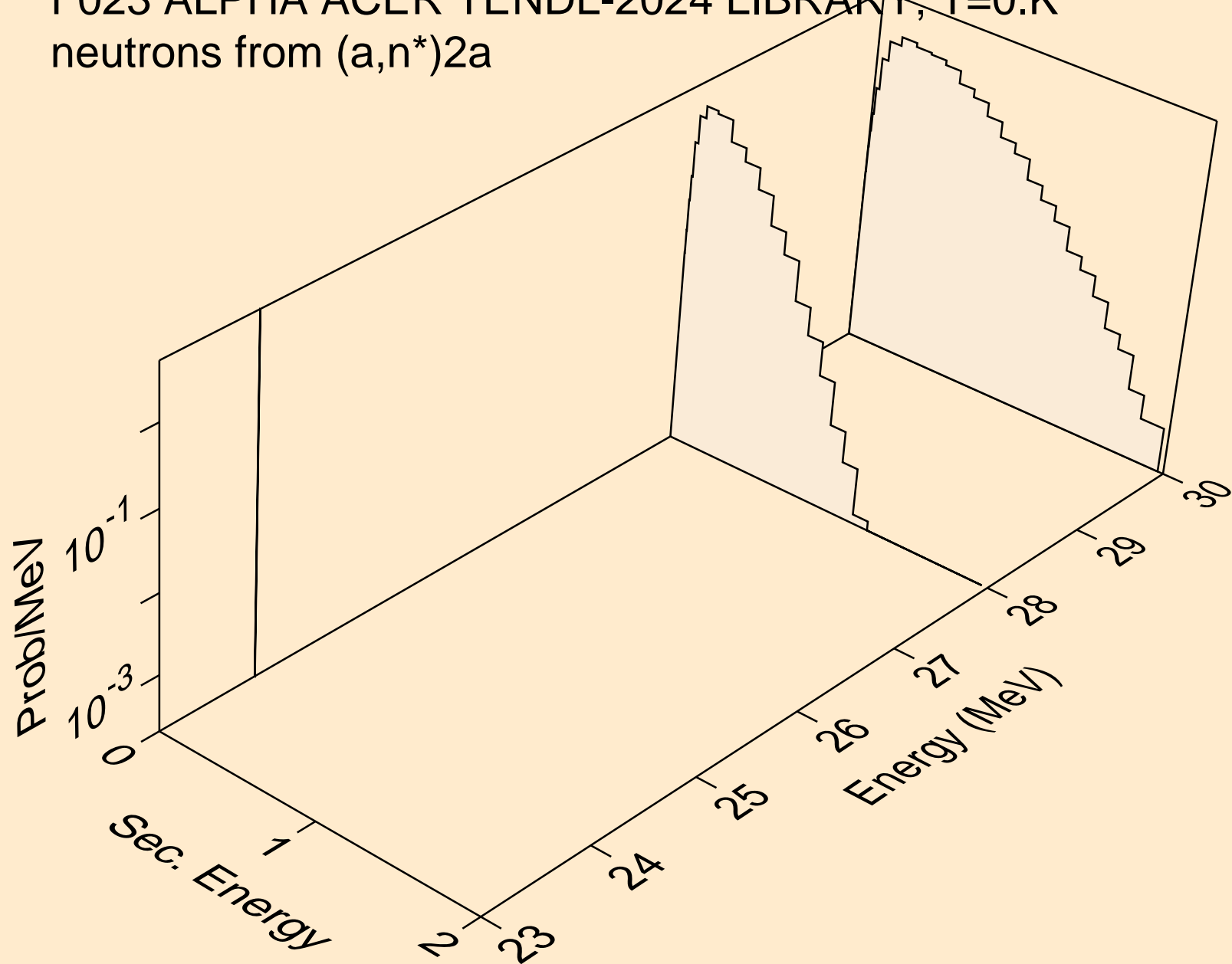

F023 ALPHA ACER TENDL-2024 LIBRARY; T=0.K
neutrons from (a,n*)d

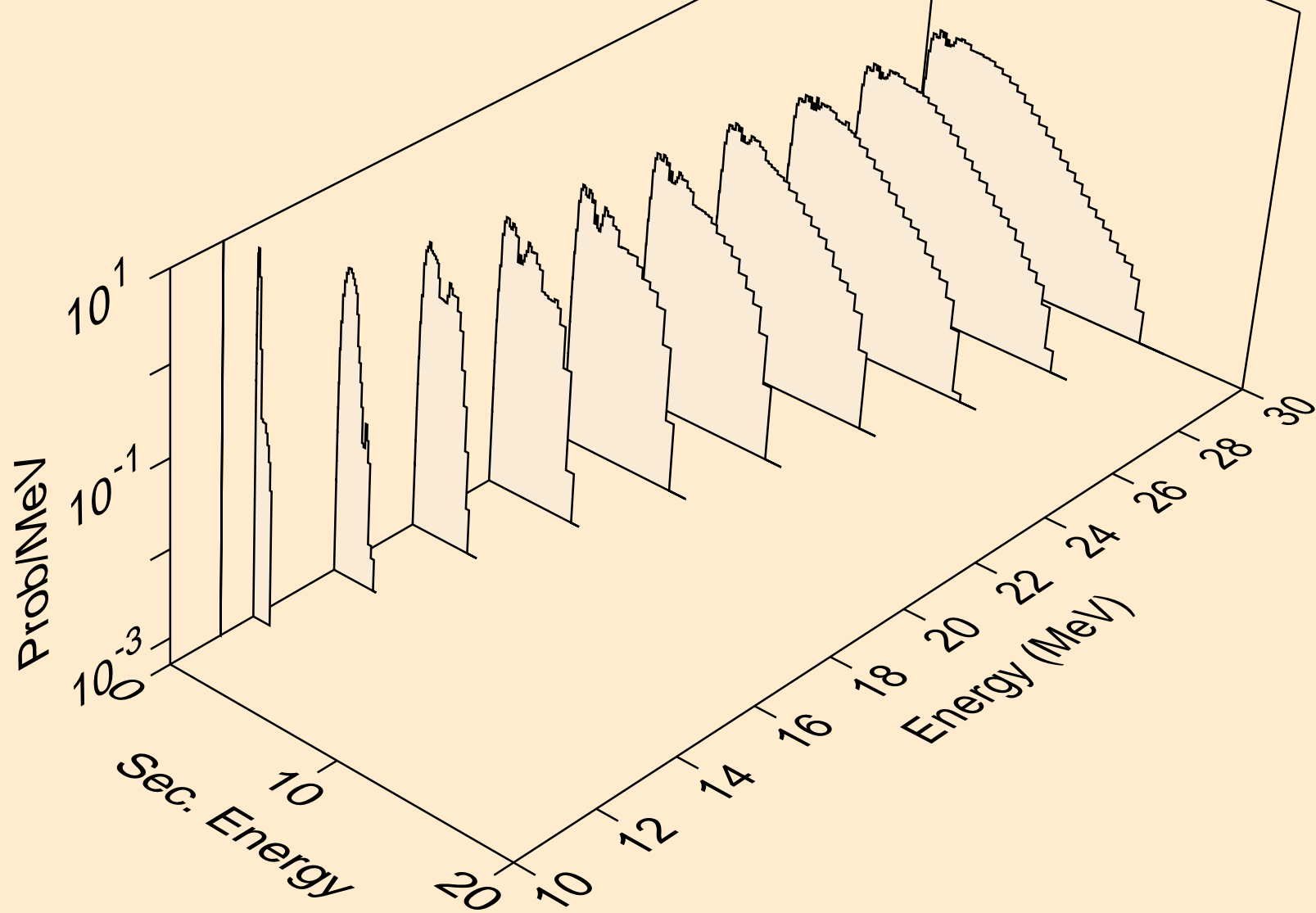

F023 ALPHA ACER TENDL-2024 LIBRARY; T=0.K
neutrons from (a,n*)t

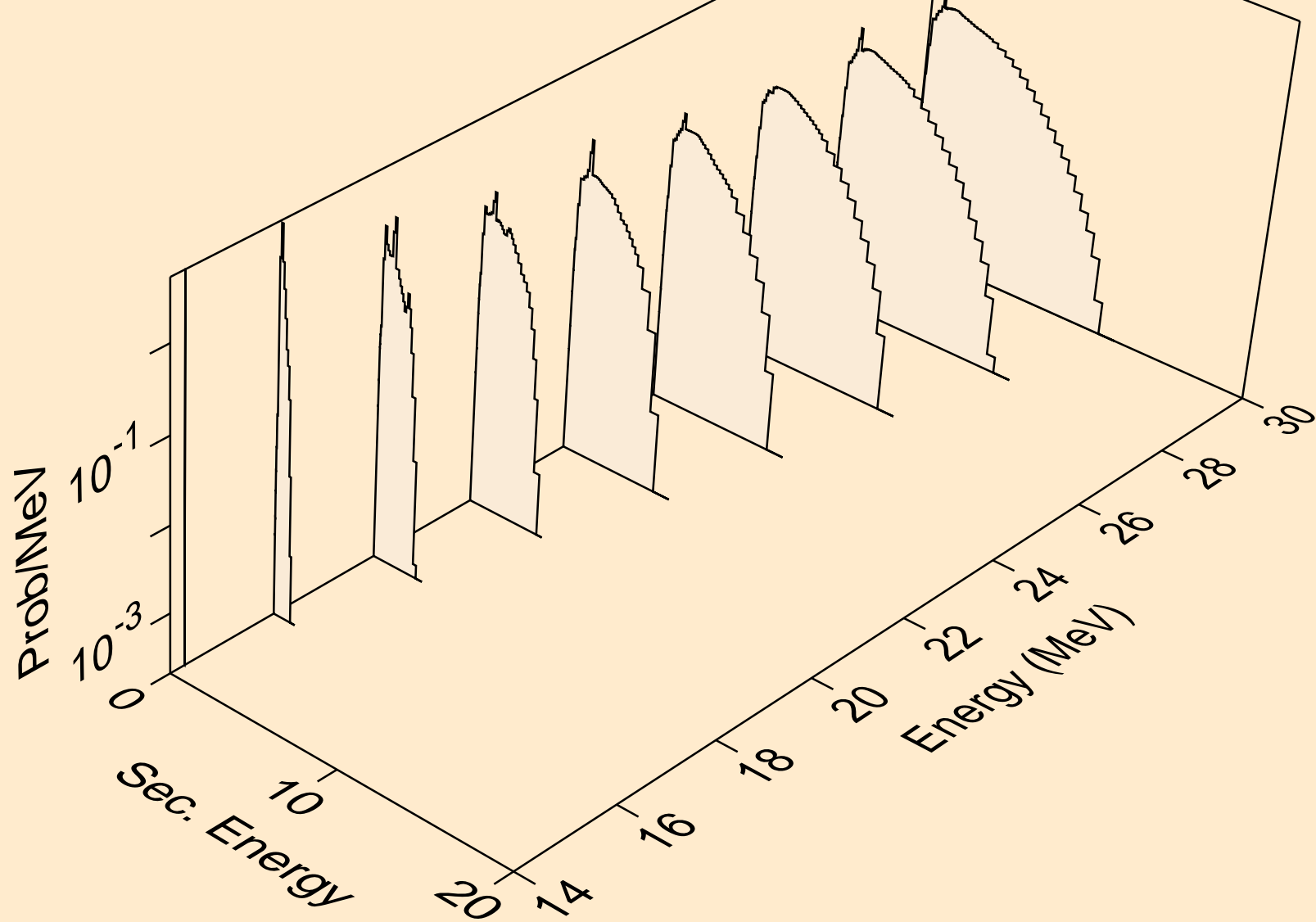

F023 ALPHA ACER TENDL-2024 LIBRARY; T=0.K
neutrons from (a,n*)he3

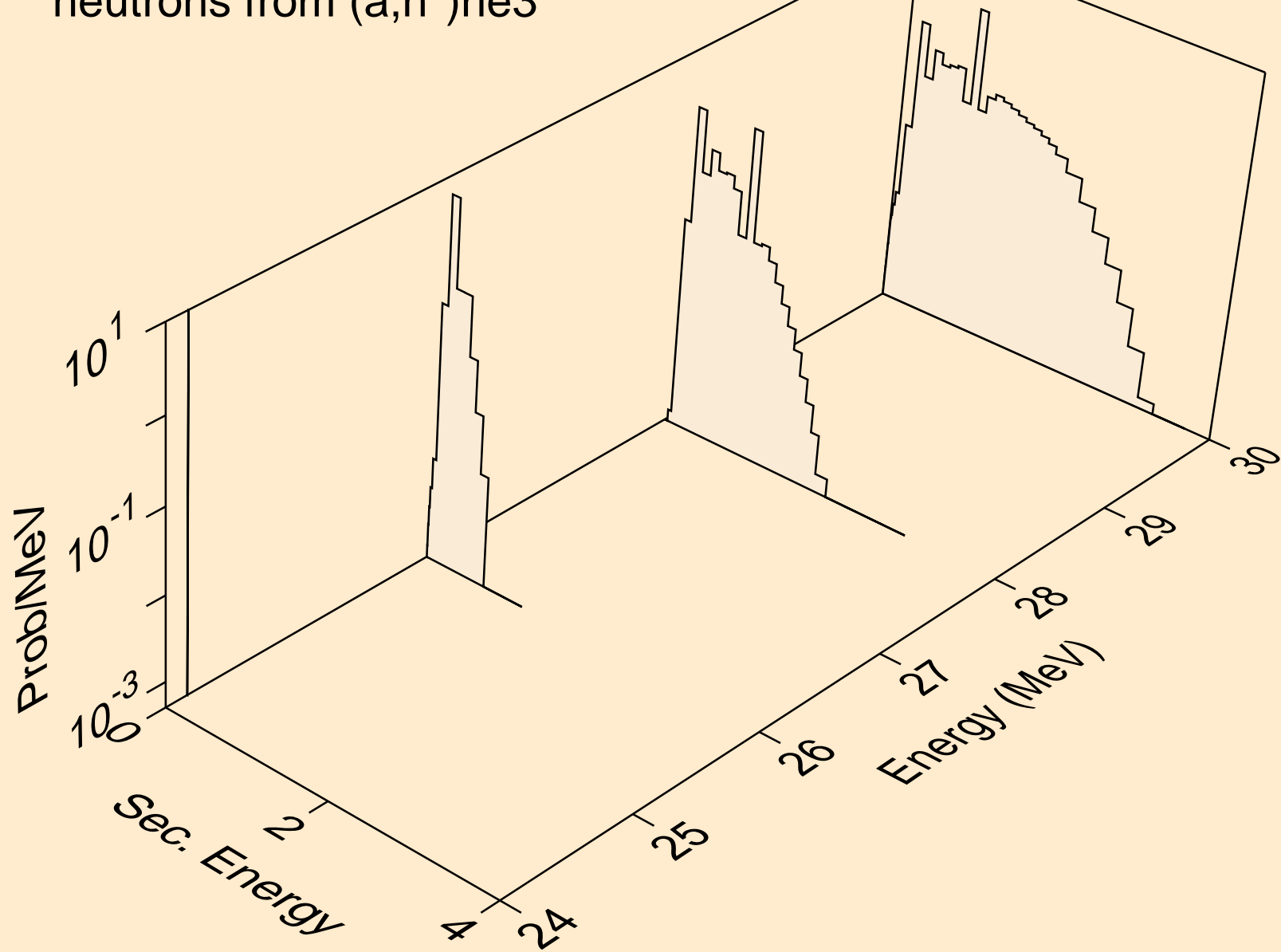

F023 ALPHA ACER TENDL-2024 LIBRARY; T=0.K
neutrons from (a,4n)

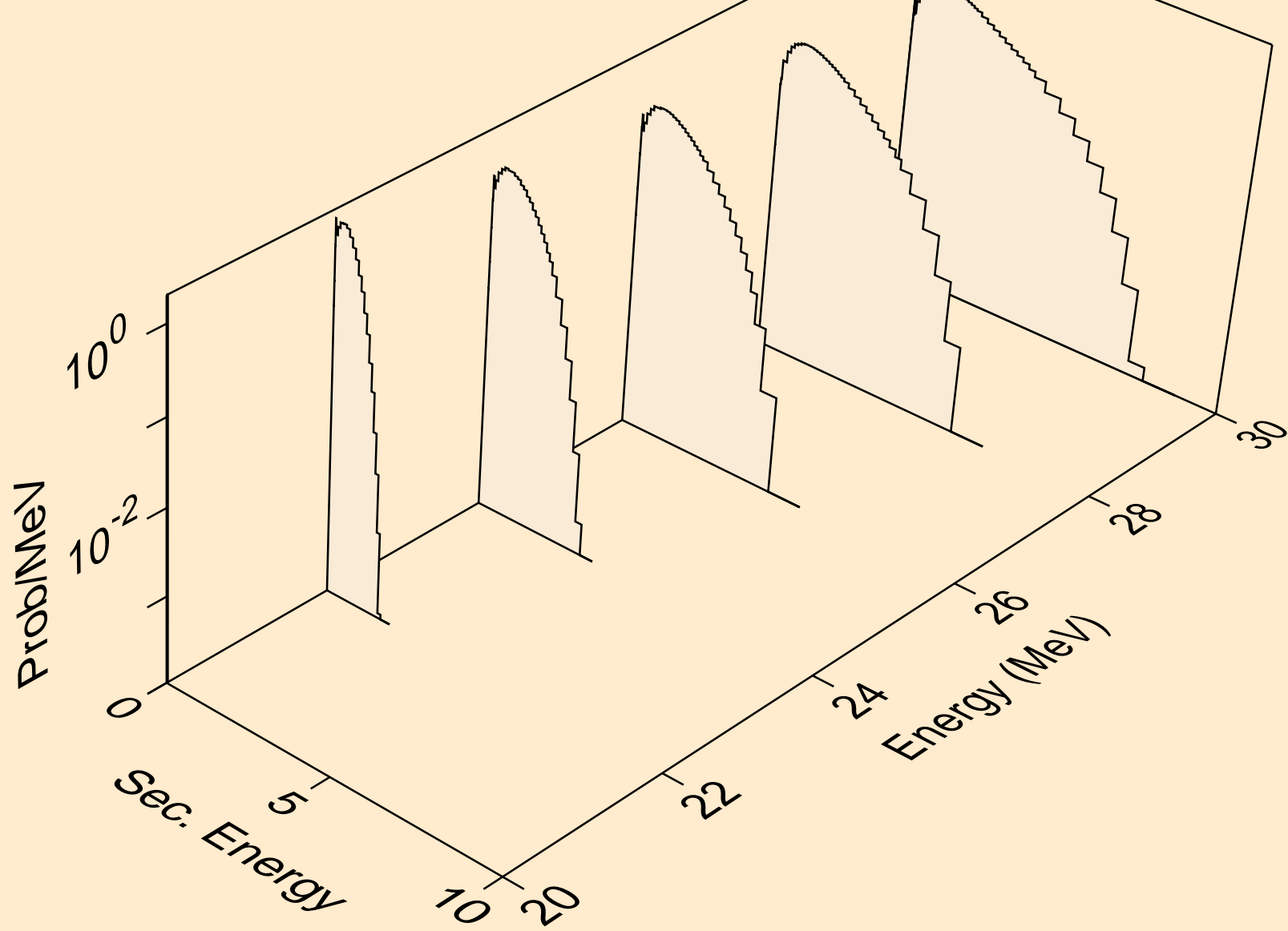

F023 ALPHA ACER TENDL-2024 LIBRARY; T=0.K
neutrons from (a,2np)

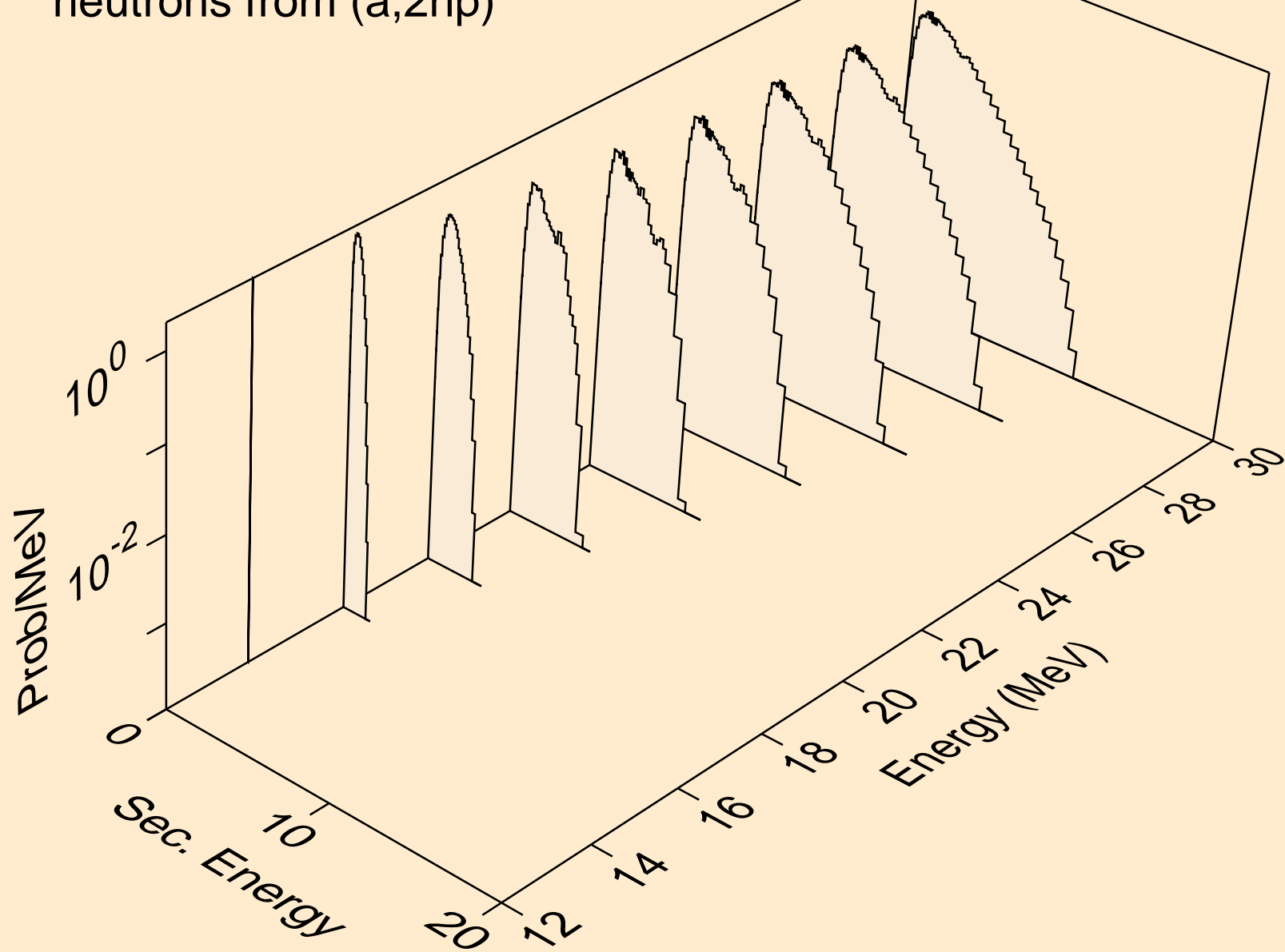

F023 ALPHA ACER TENDL-2024 LIBRARY; T=0.K
neutrons from (a,3np)

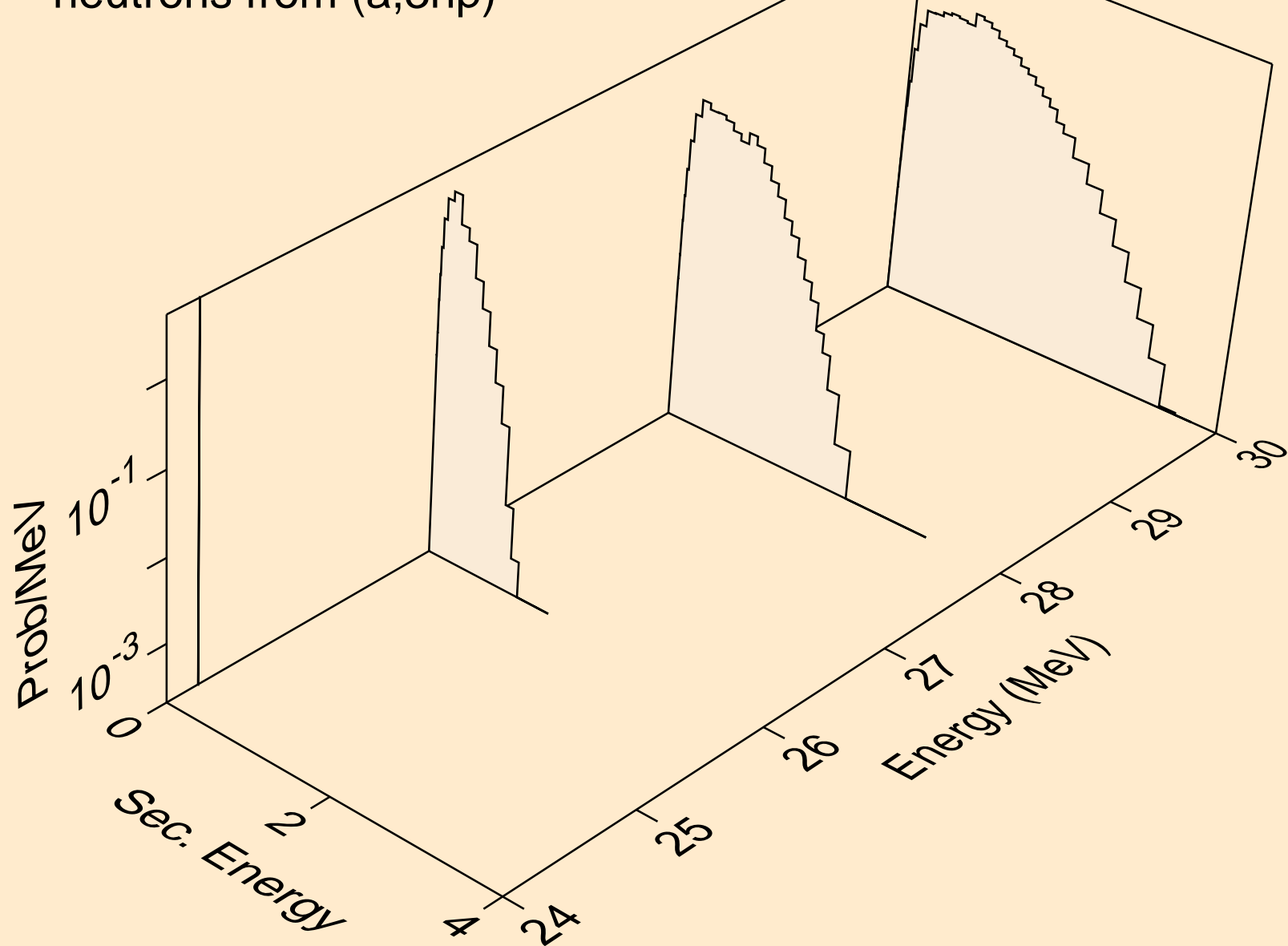

F023 ALPHA ACER TENDL-2024 LIBRARY; T=0.K
neutrons from (a,npa)

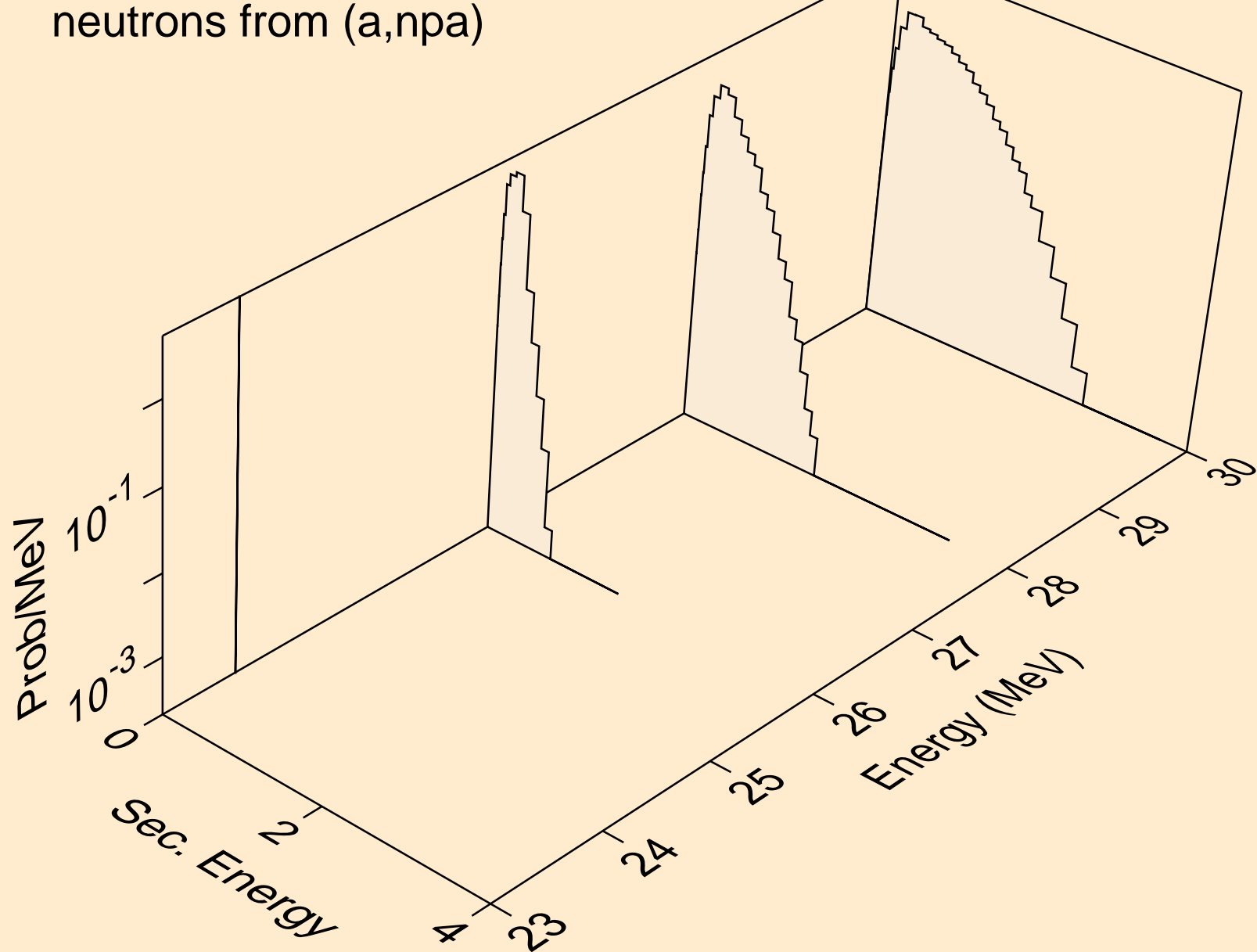

F023 ALPHA ACER TENDL-2024 LIBRARY; T=0.K
protons from (a,x)

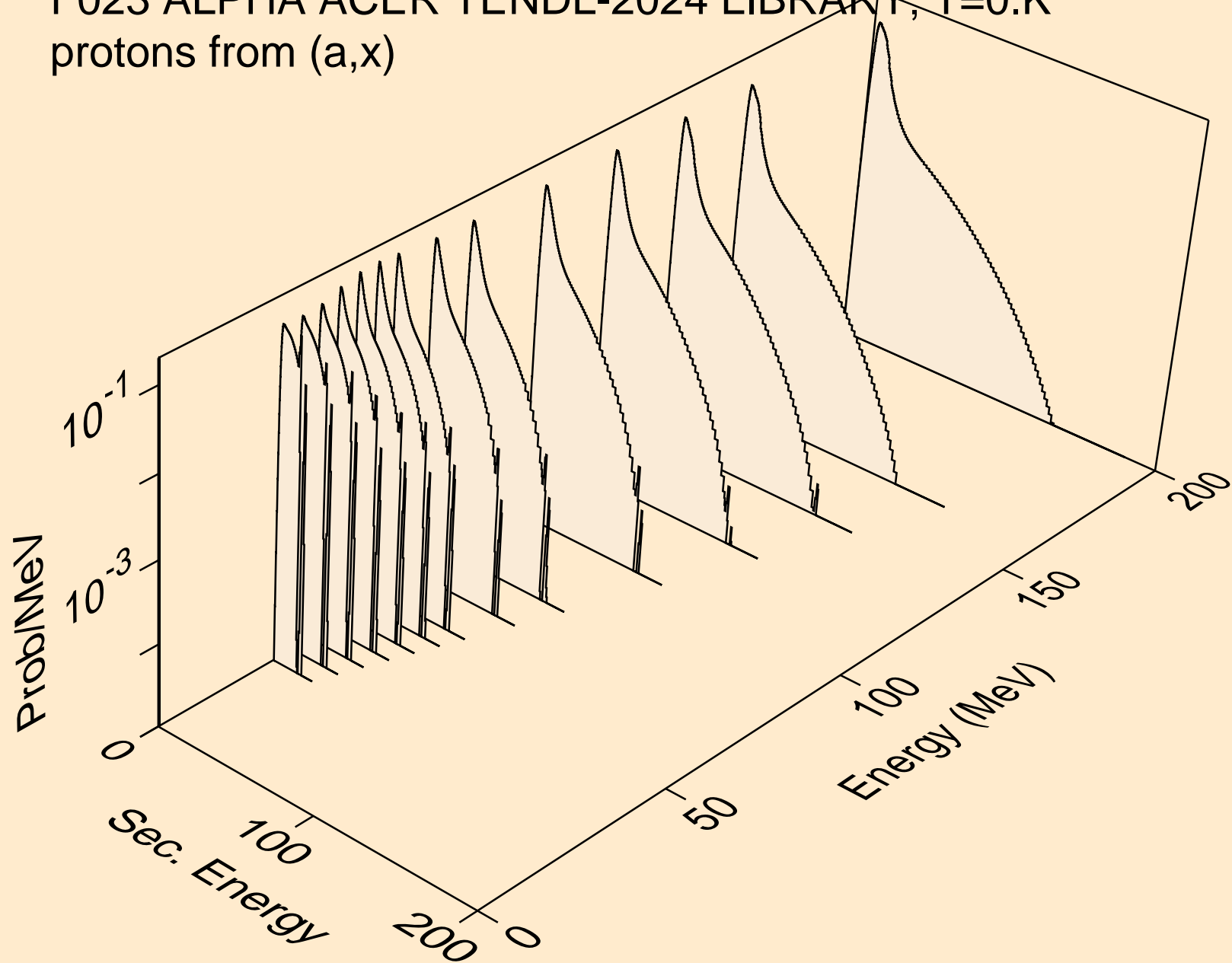

F023 ALPHA ACER TENDL-2024 LIBRARY; T=0.K
protons from (a,n*)p

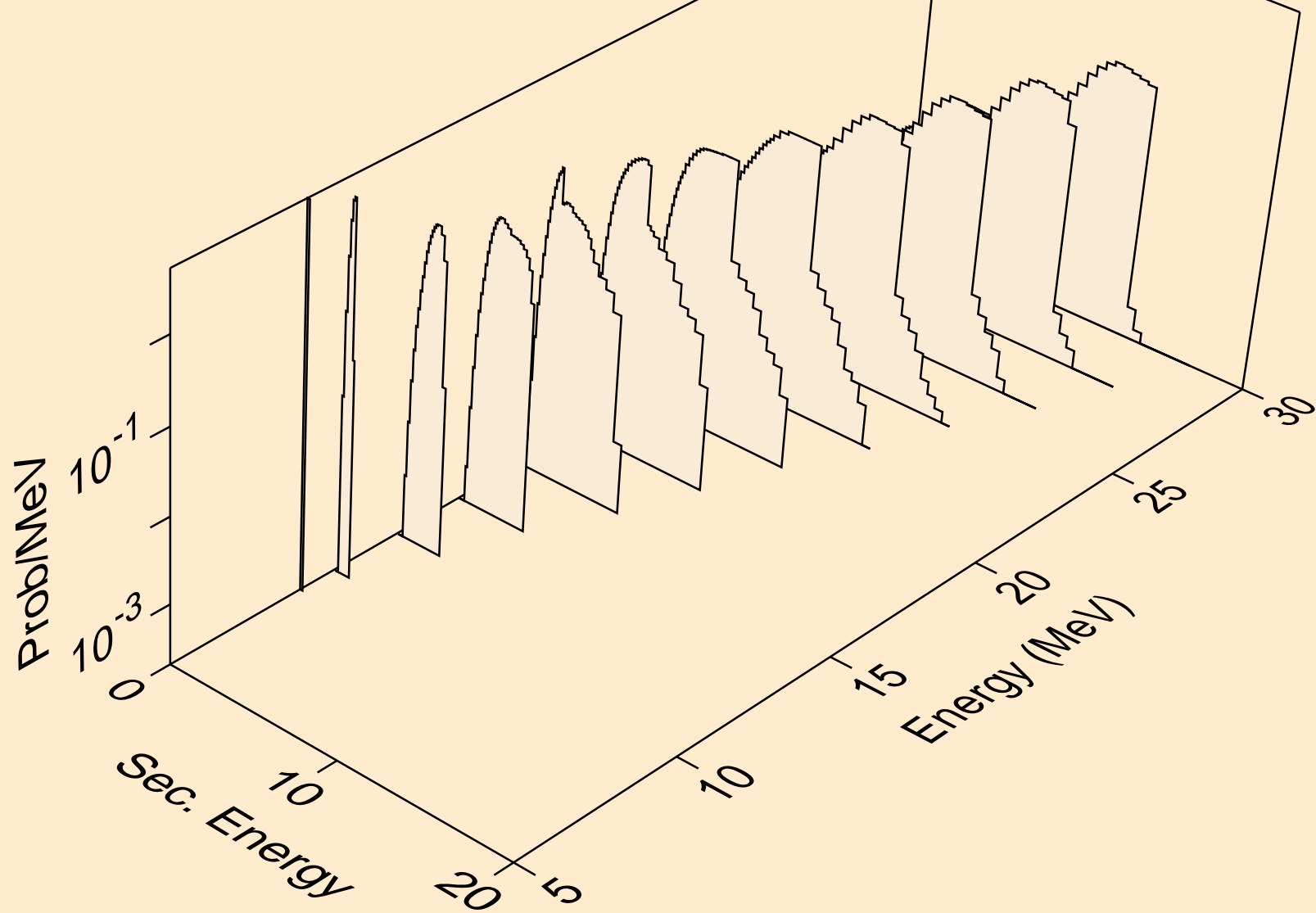

F023 ALPHA ACER TENDL-2024 LIBRARY; T=0.K
protons from (a,2np)

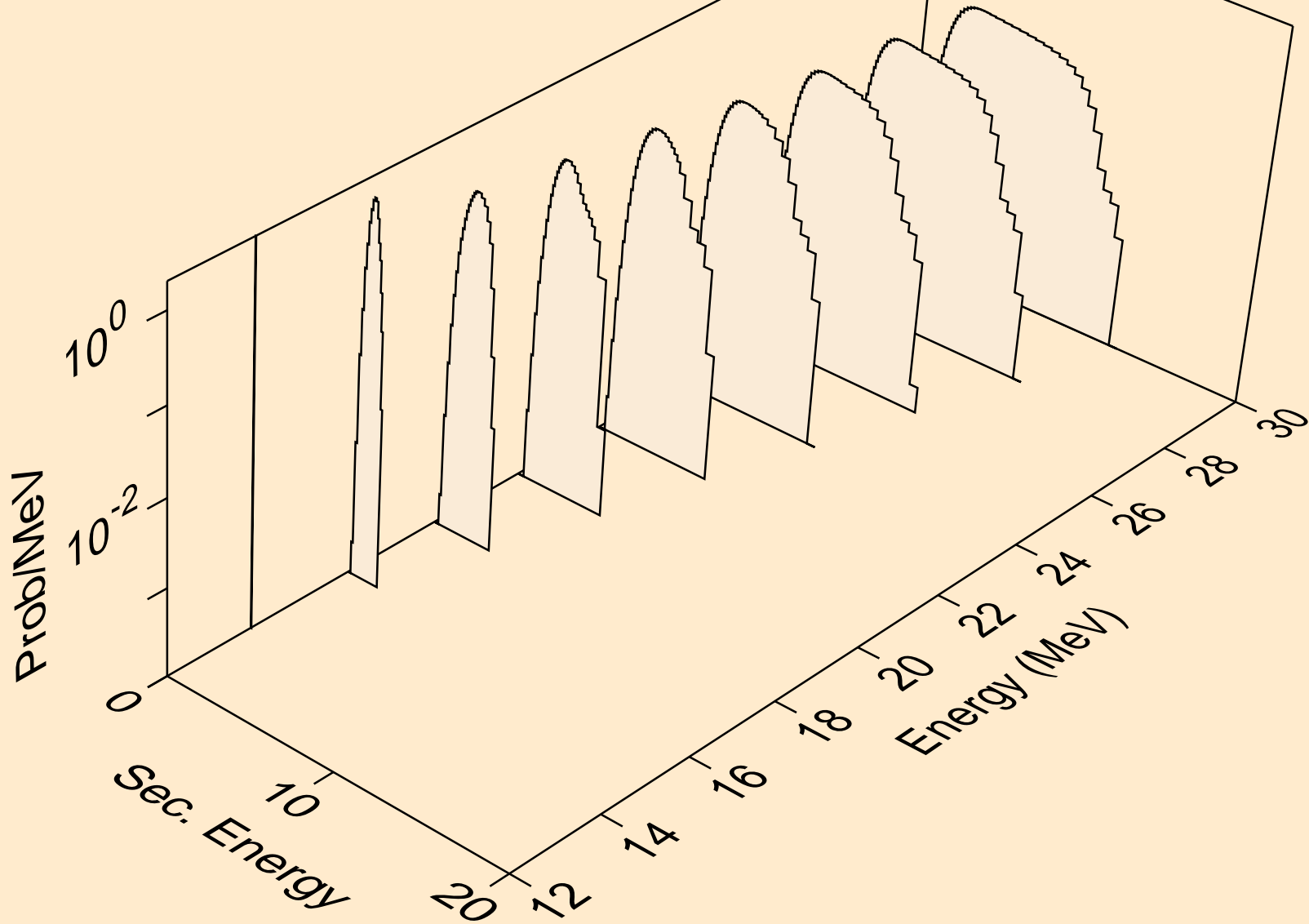

F023 ALPHA ACER TENDL-2024 LIBRARY; T=0.K
protons from (a,3np)

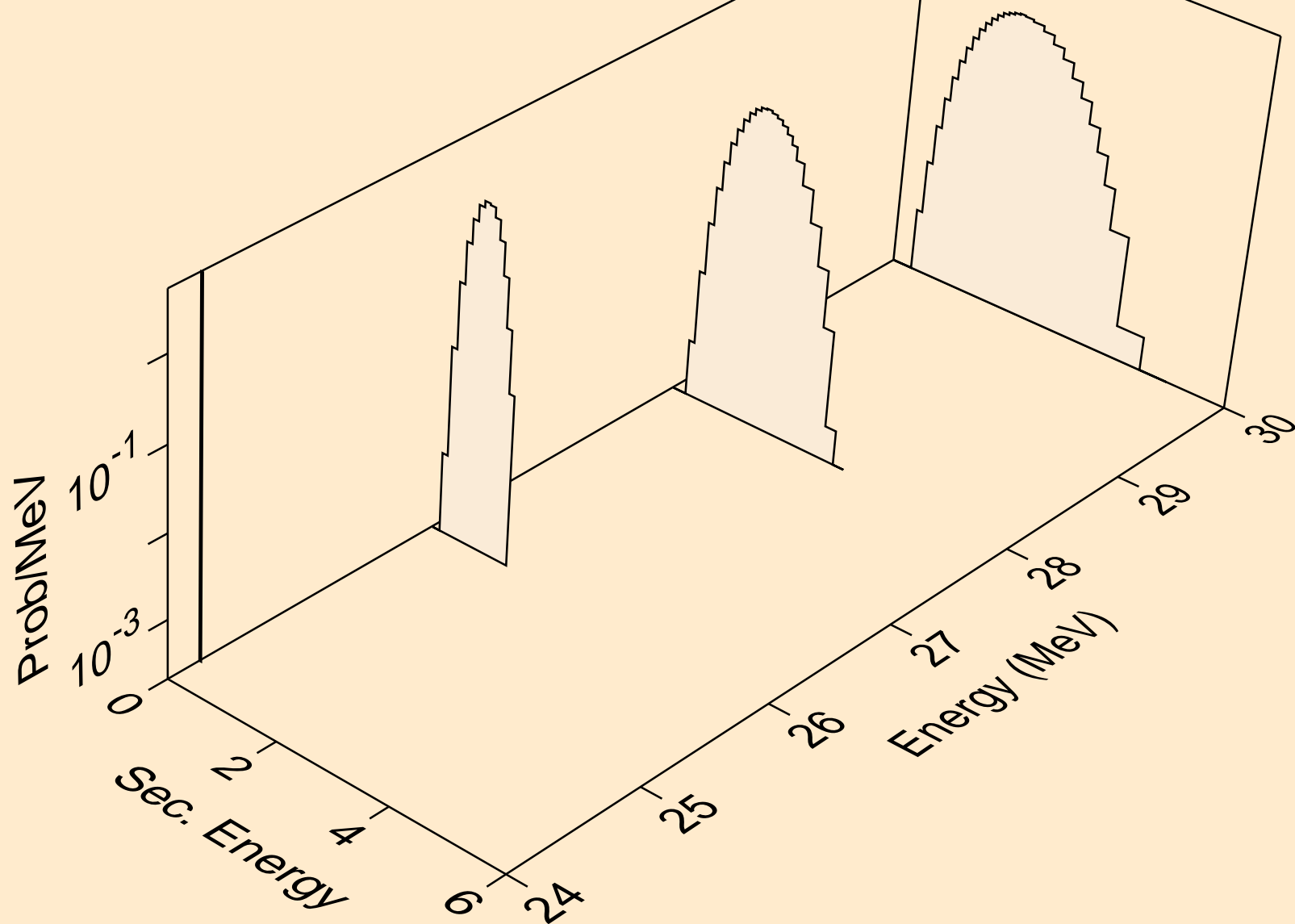

F023 ALPHA ACER TENDL-2024 LIBRARY; T=0.K
protons from (a,npa)

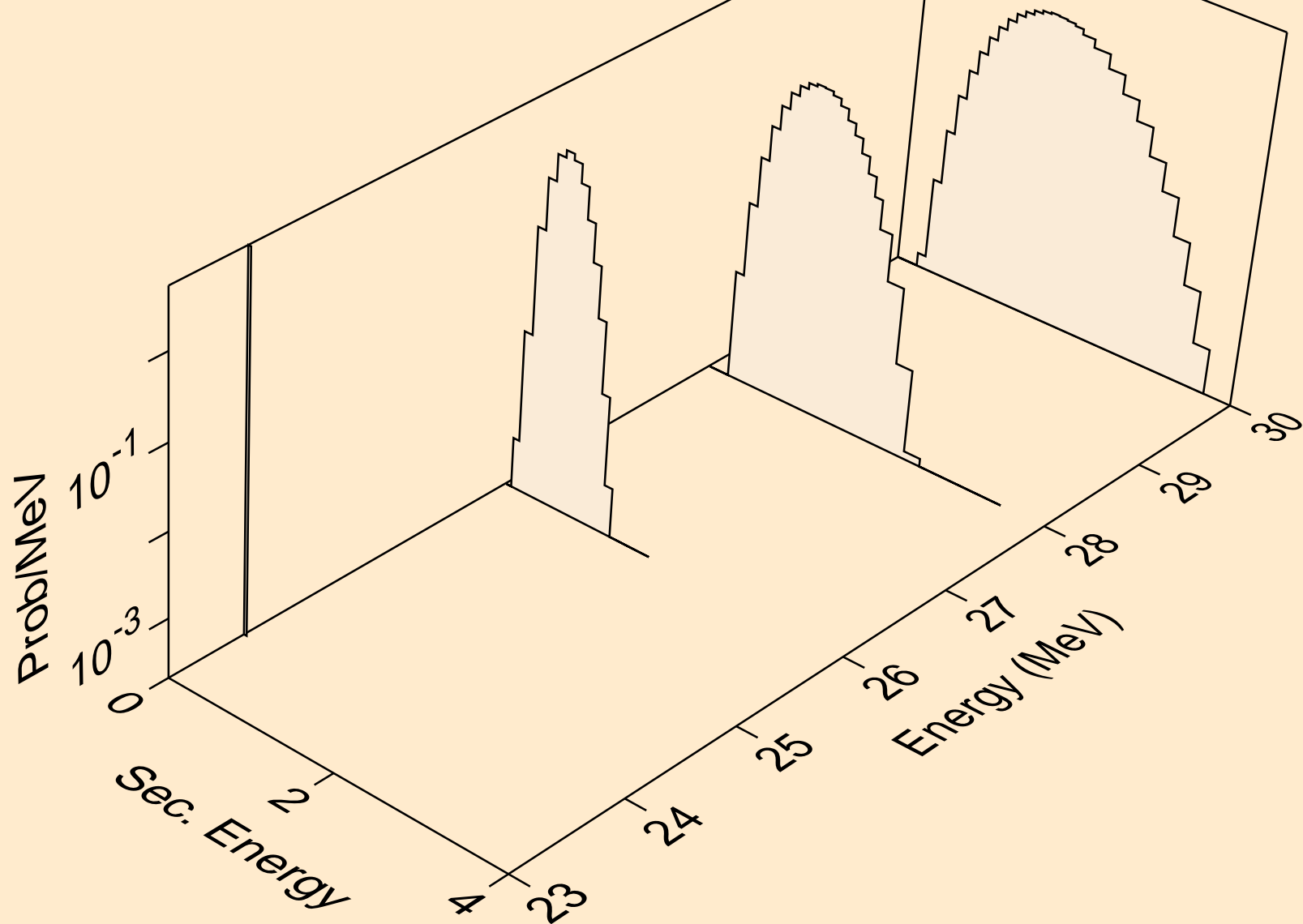

F023 ALPHA ACER TENDL-2024 LIBRARY; T=0.K
protons from (a,p)

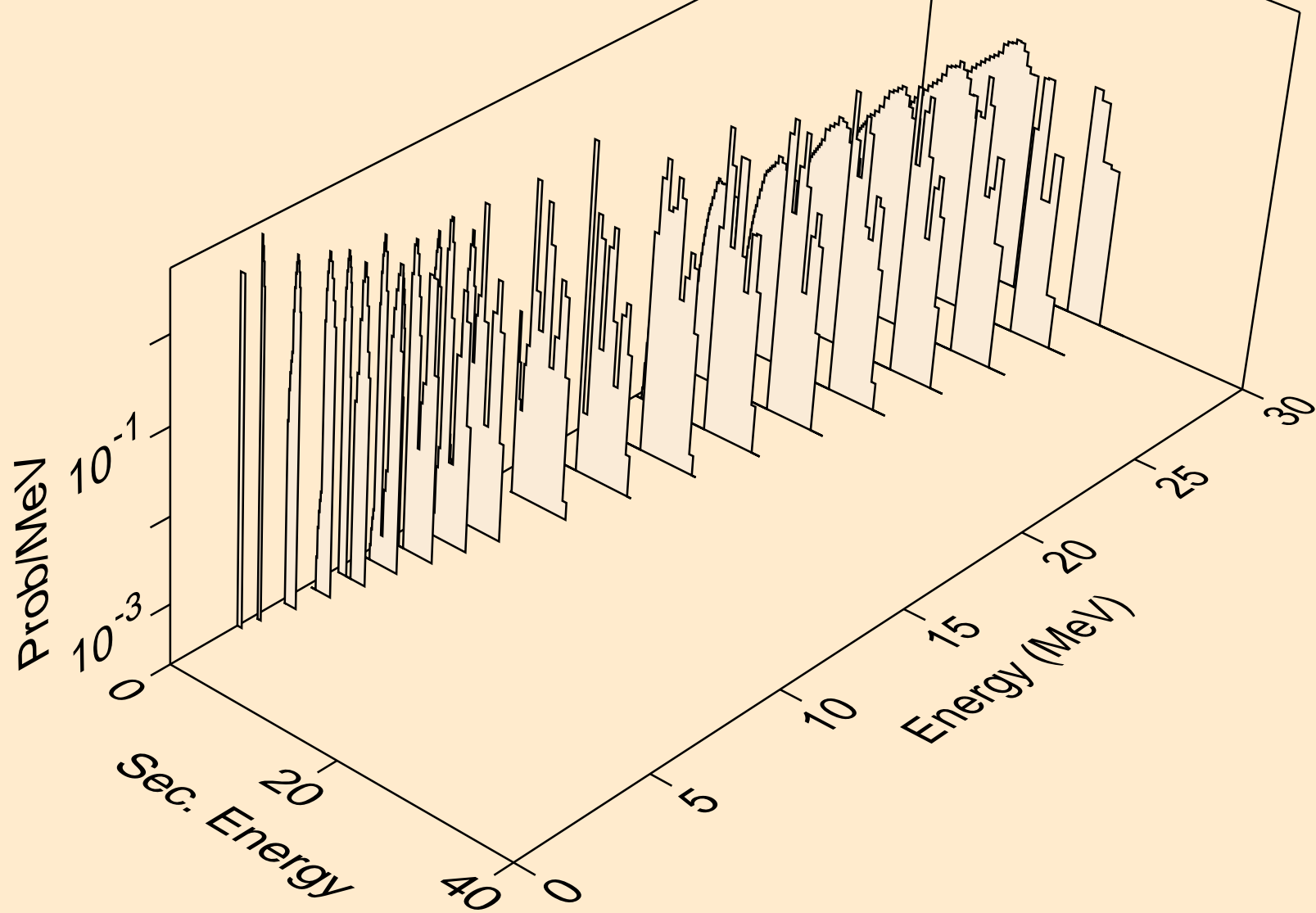

F023 ALPHA ACER TENDL-2024 LIBRARY; T=0.K
protons from (a,2p)

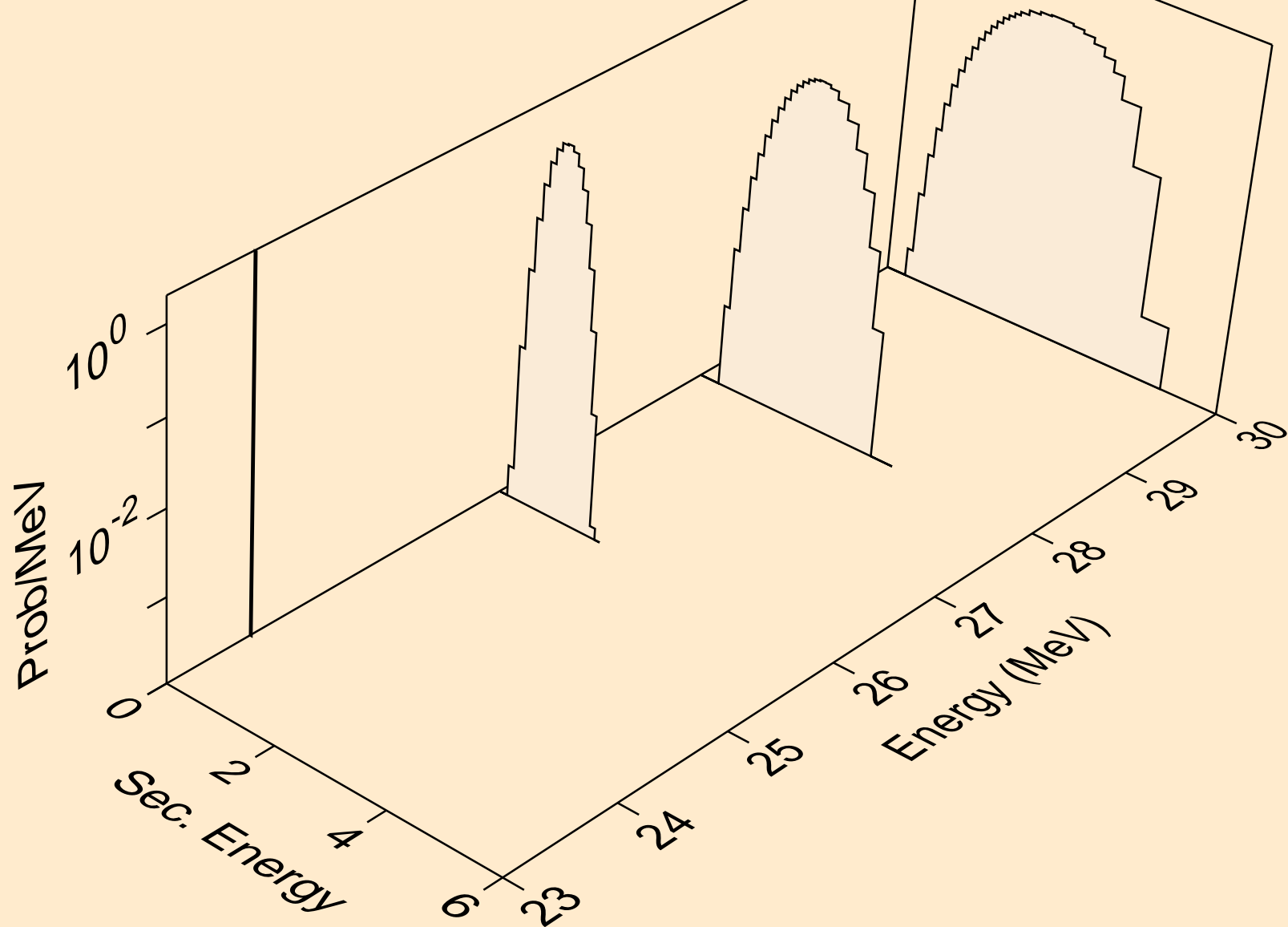

F023 ALPHA ACER TENDL-2024 LIBRARY; T=0.K
protons from (a,pa)

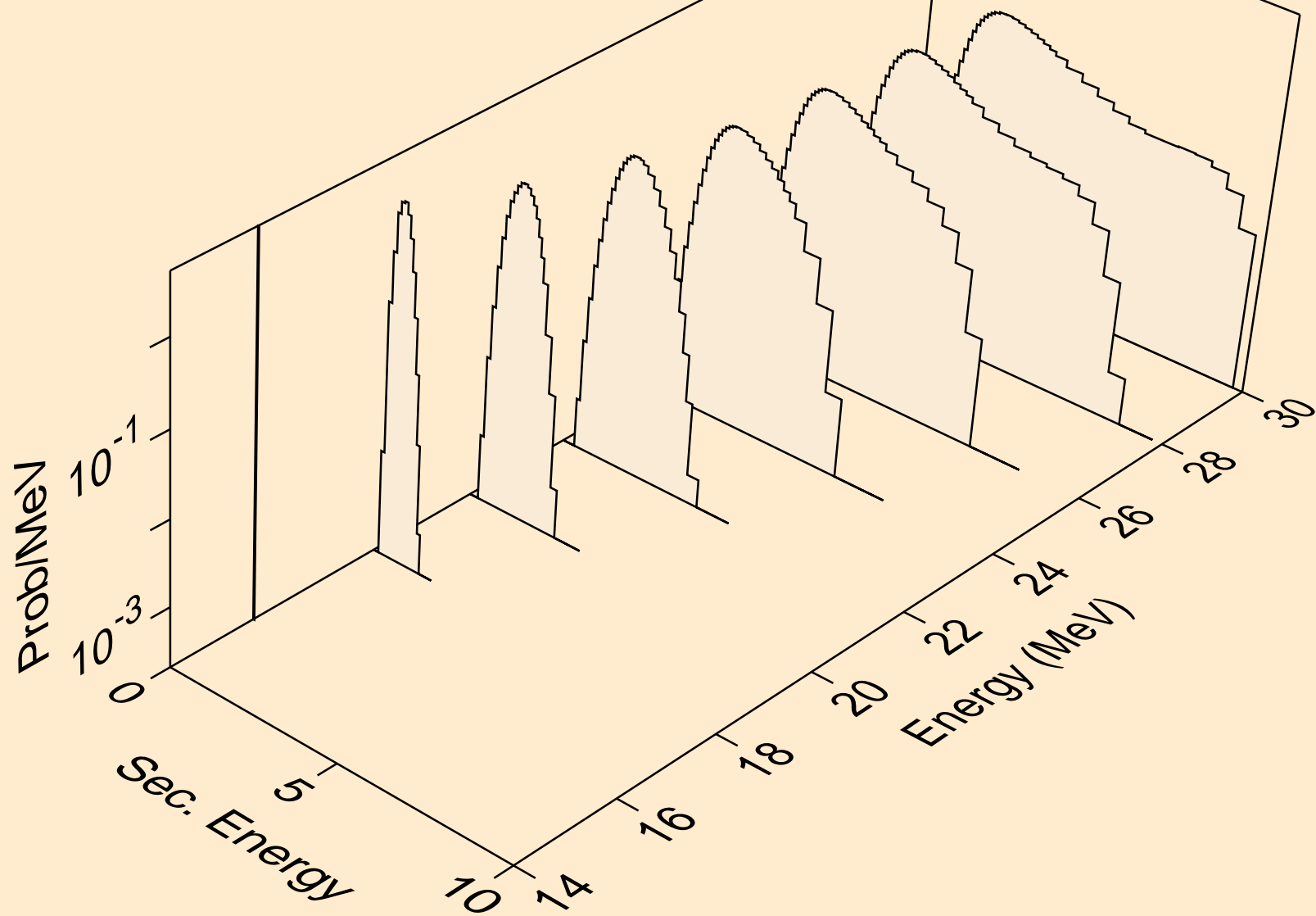

F023 ALPHA ACER TENDL-2024 LIBRARY; T=0.K
protons from (a,pd)

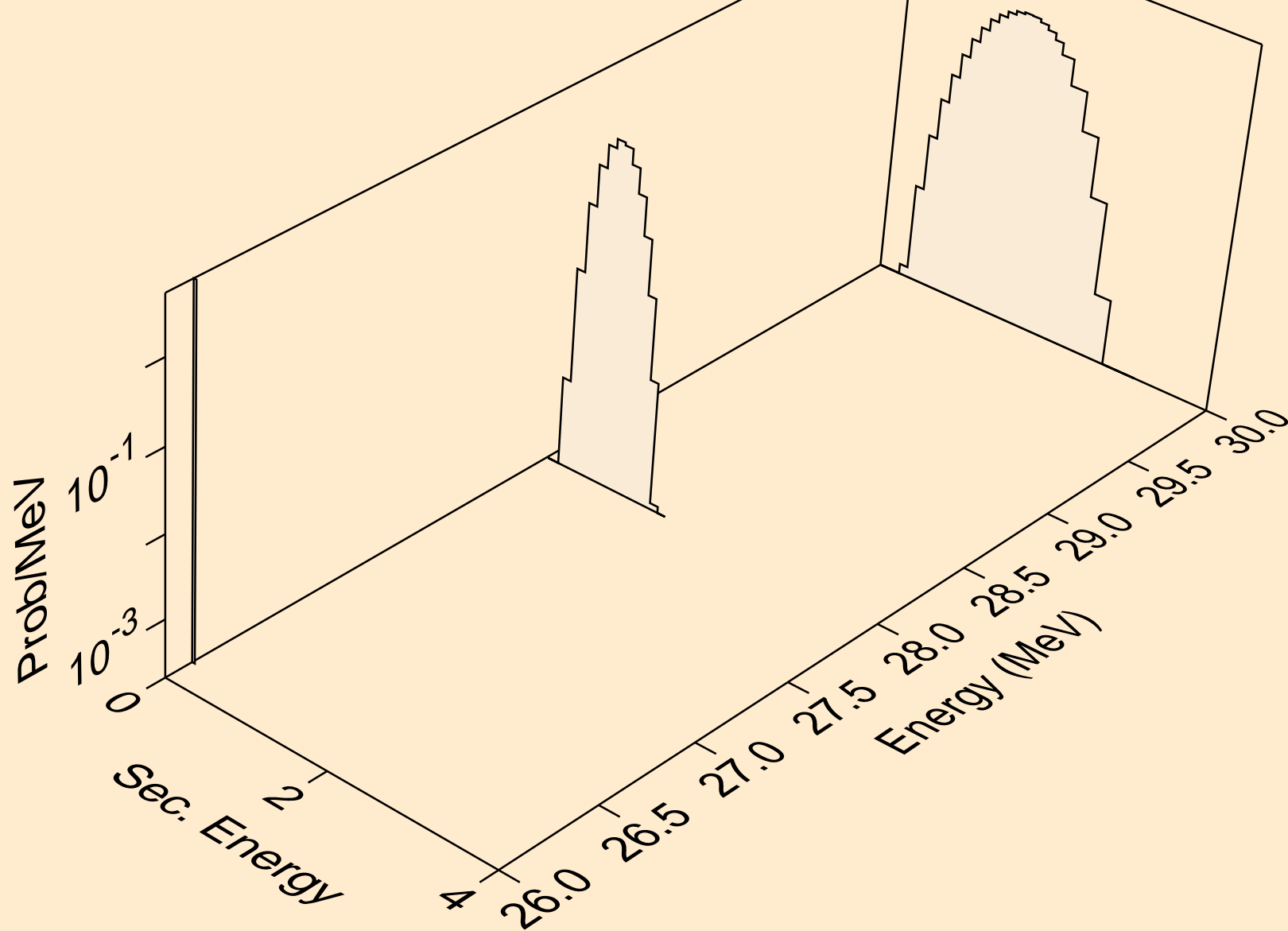

F023 ALPHA ACER TENDL-2024 LIBRARY; T=0.K
protons from (a,pt)

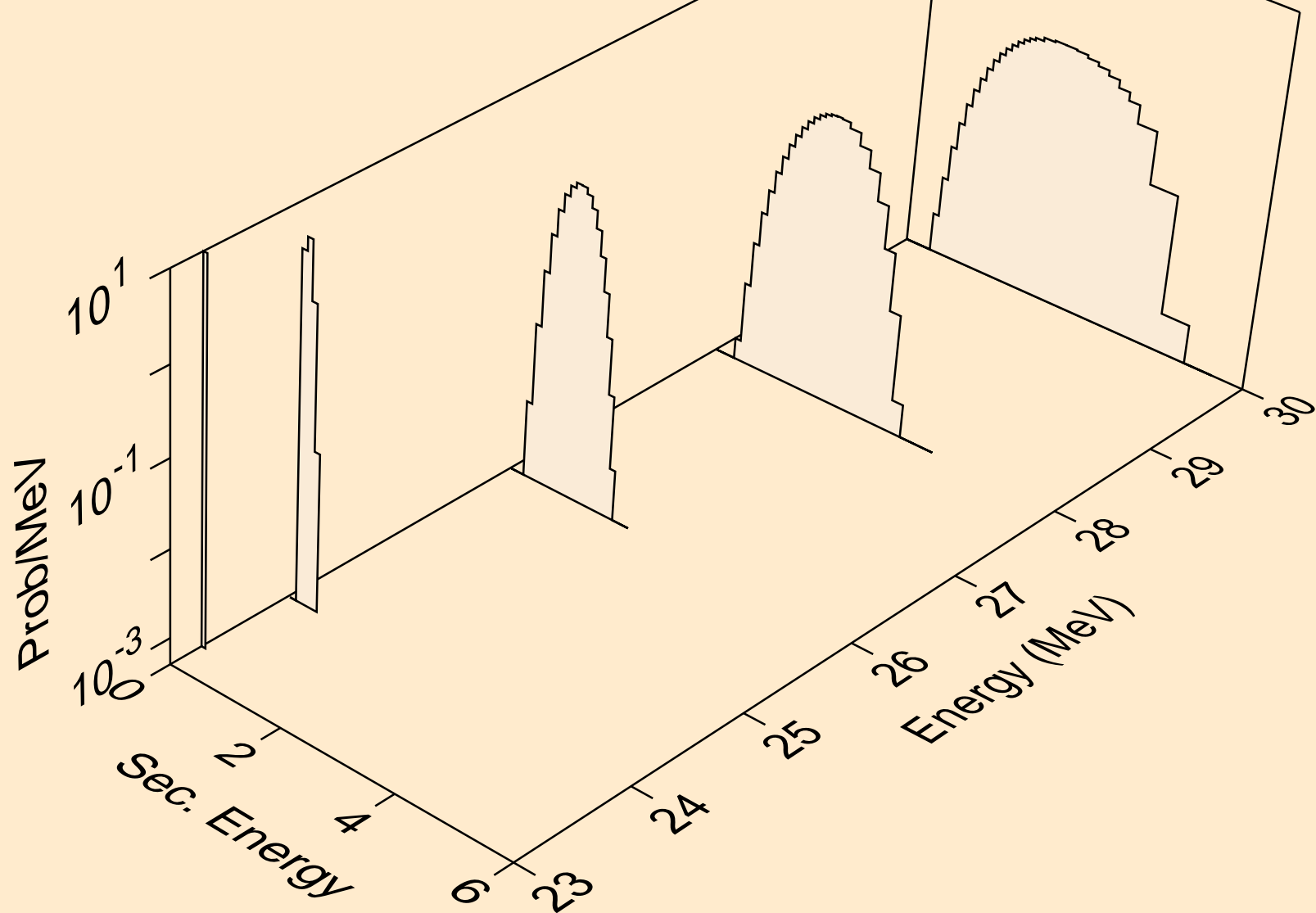

F023 ALPHA ACER TENDL-2024 LIBRARY; T=0.K
deuterons from (a,x)

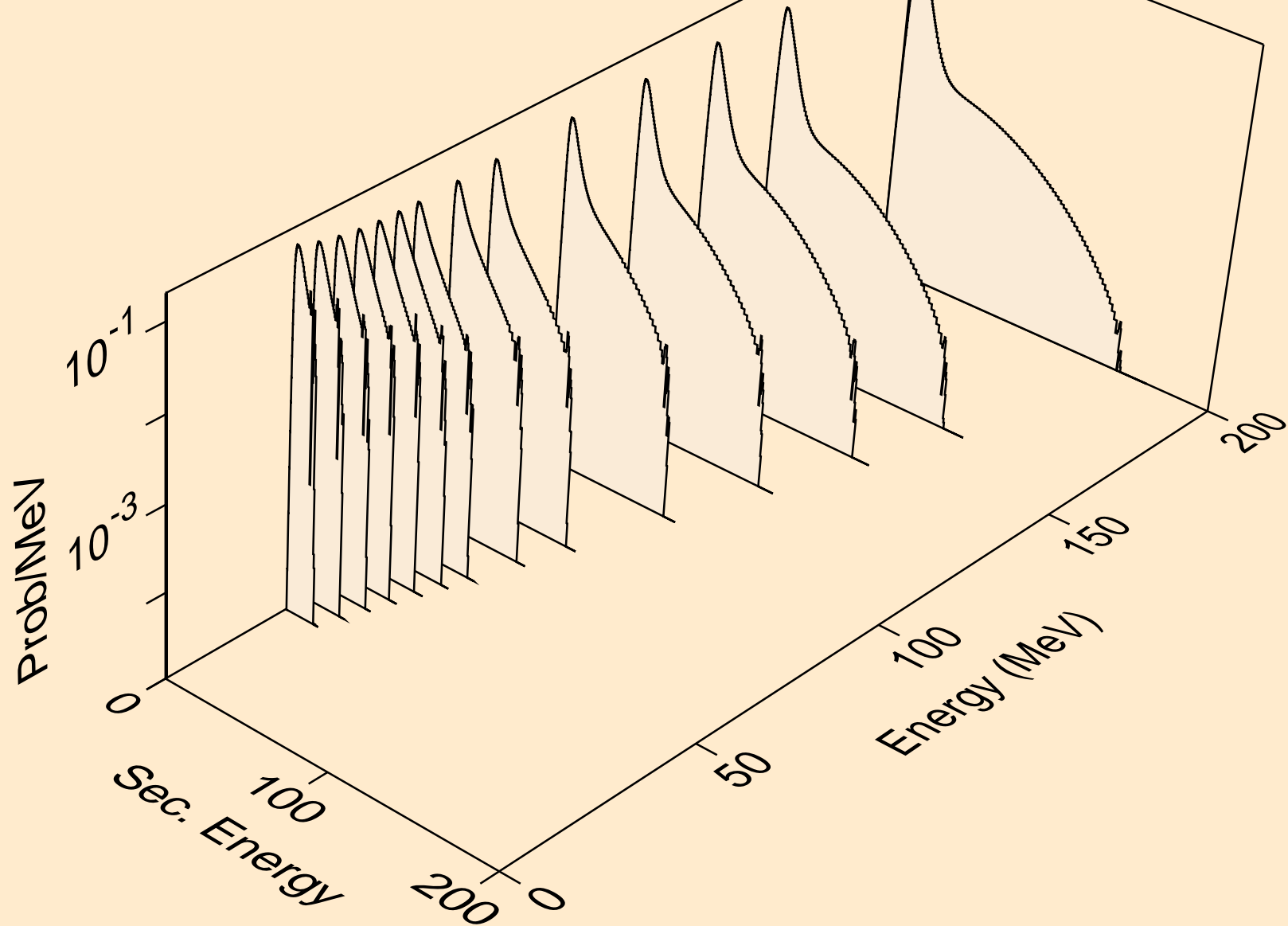

F023 ALPHA ACER TENDL-2024 LIBRARY; T=0.K
deuterons from (a,2nd)

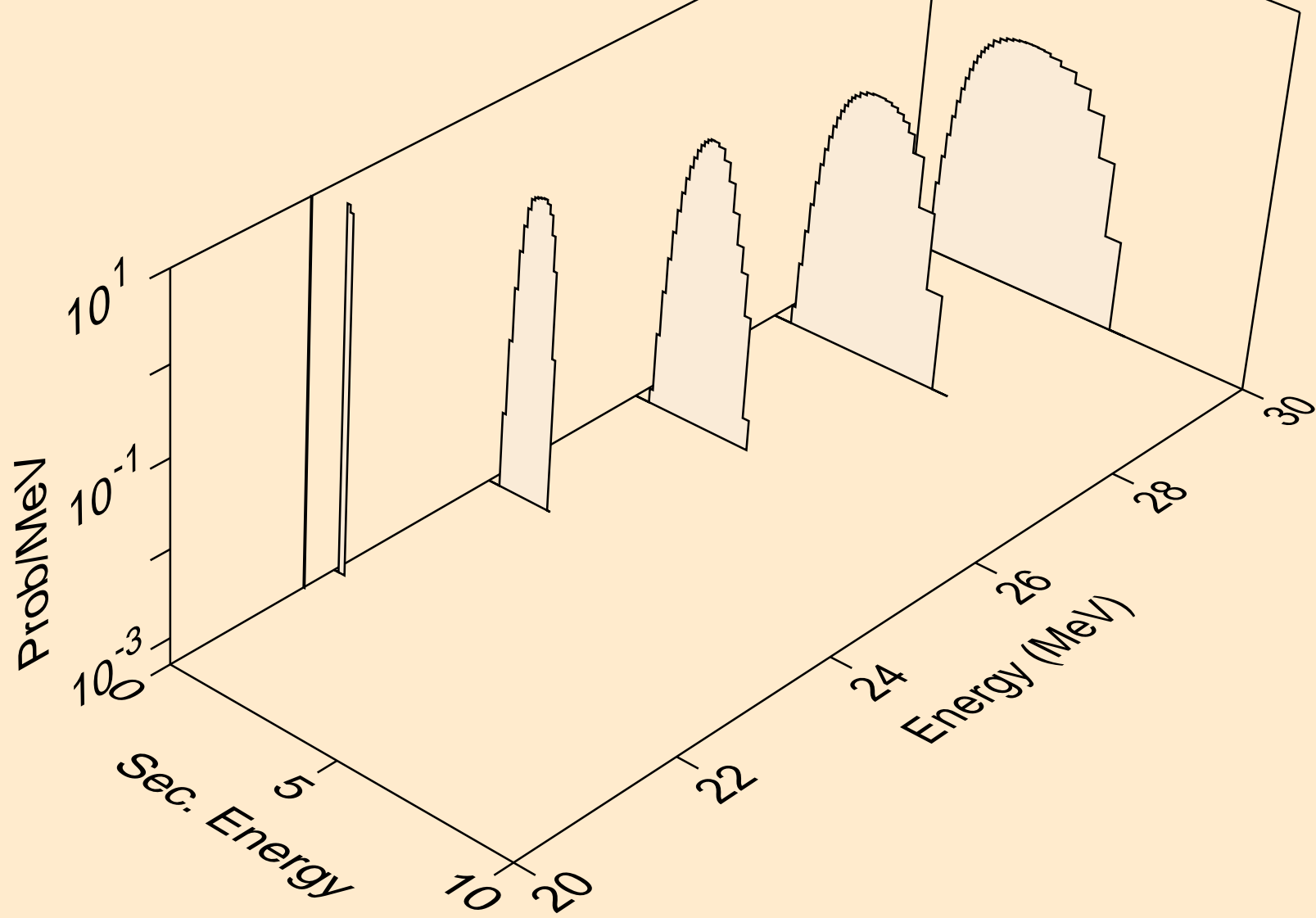

F023 ALPHA ACER TENDL-2024 LIBRARY; T=0.K
deuterons from (a,n*)d

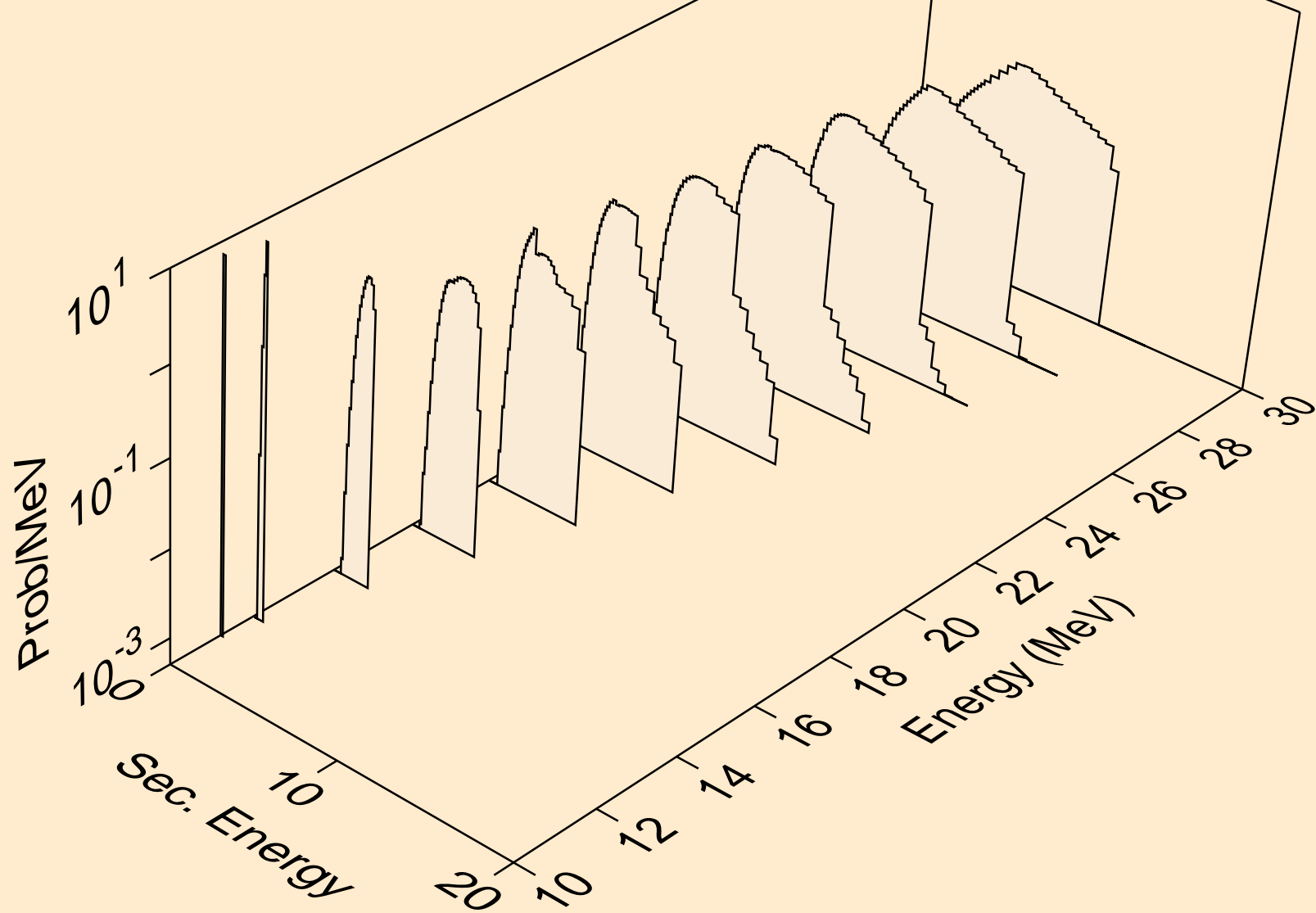

F023 ALPHA ACER TENDL-2024 LIBRARY; T=0.K
deuterons from (a,d)

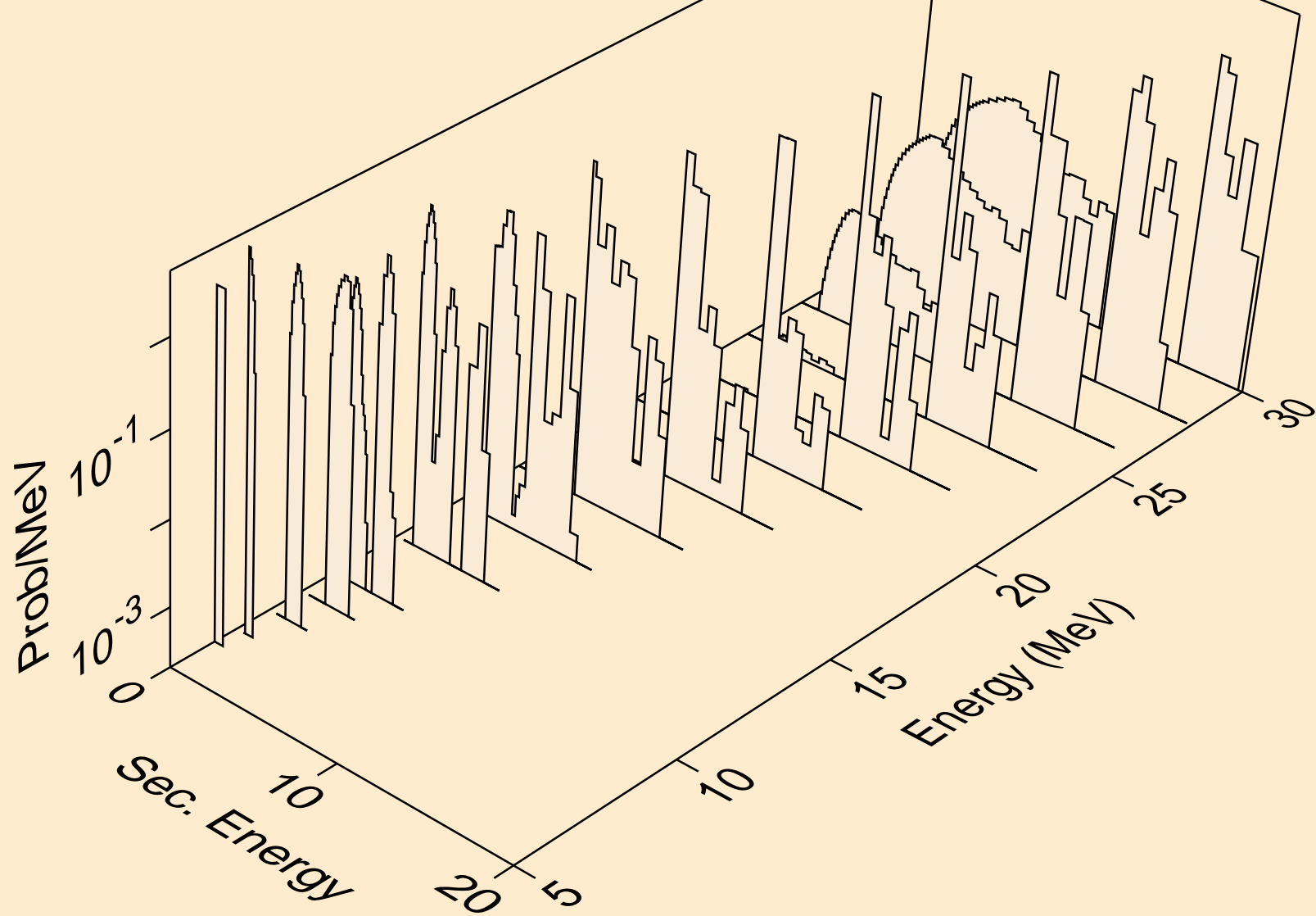

F023 ALPHA ACER TENDL-2024 LIBRARY; T=0.K
deuterons from (a,pd)

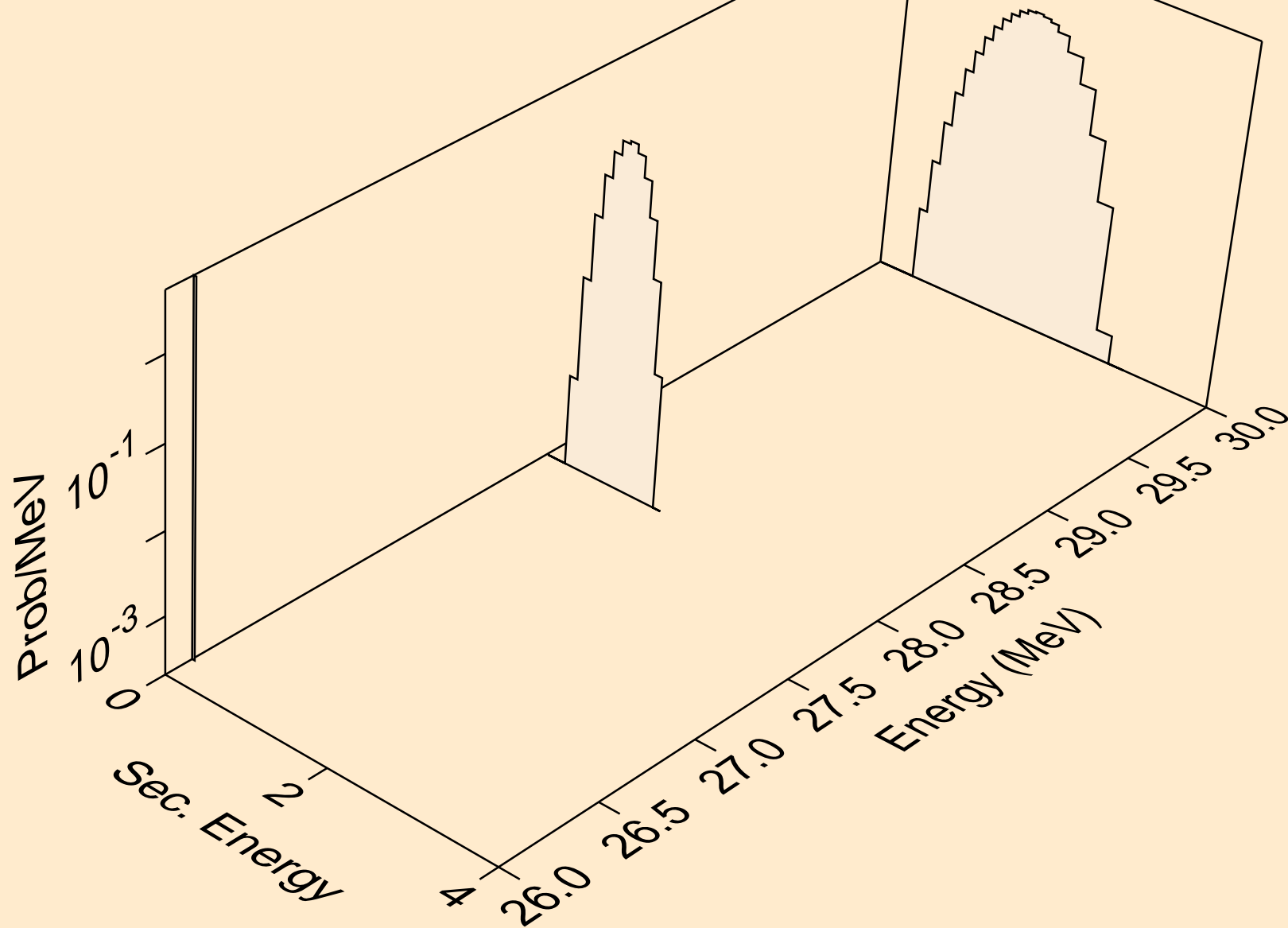

F023 ALPHA ACER TENDL-2024 LIBRARY; T=0.K
deuterons from (a,da)

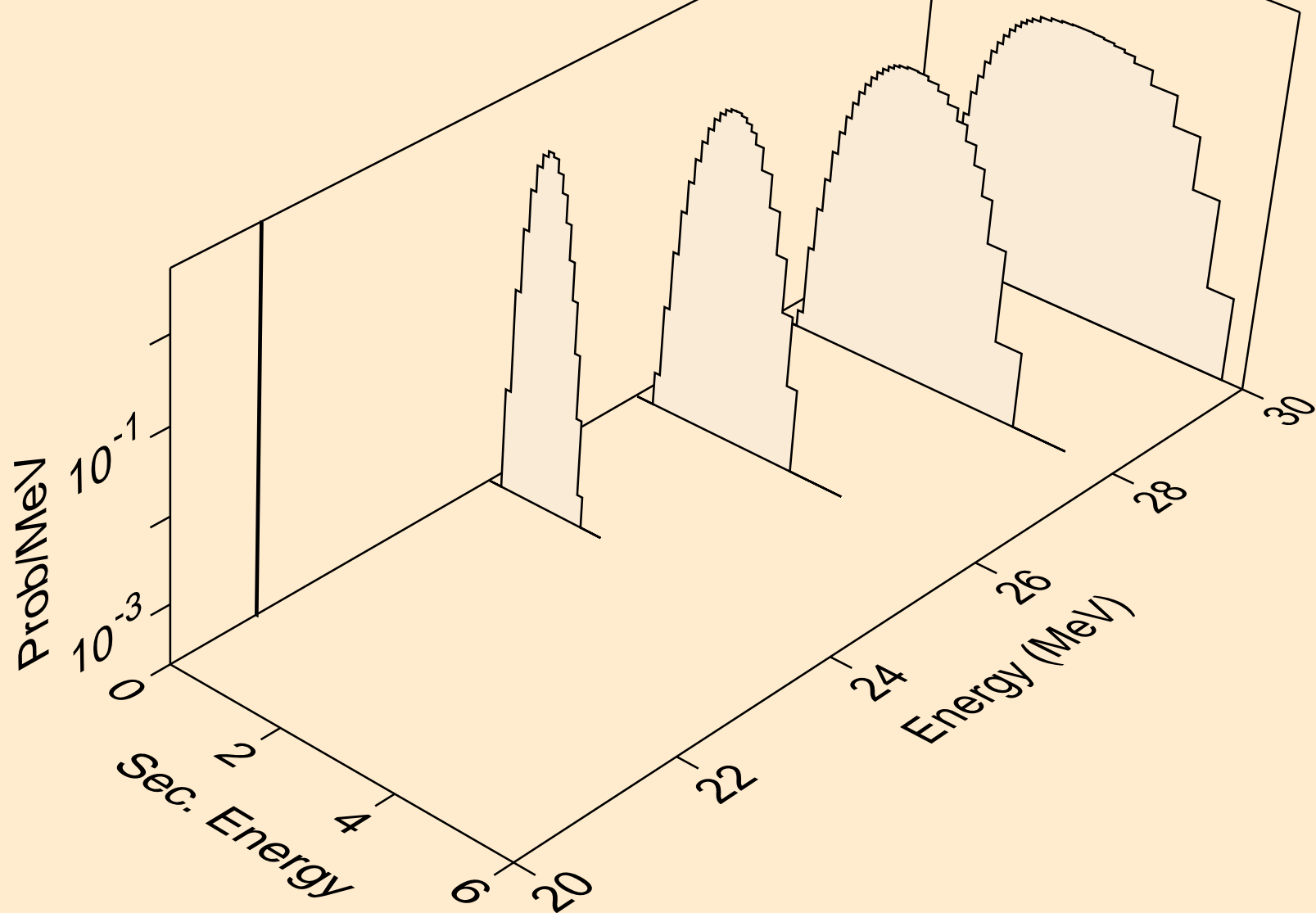

F023 ALPHA ACER TENDL-2024 LIBRARY; T=0.K
tritons from (a,x)

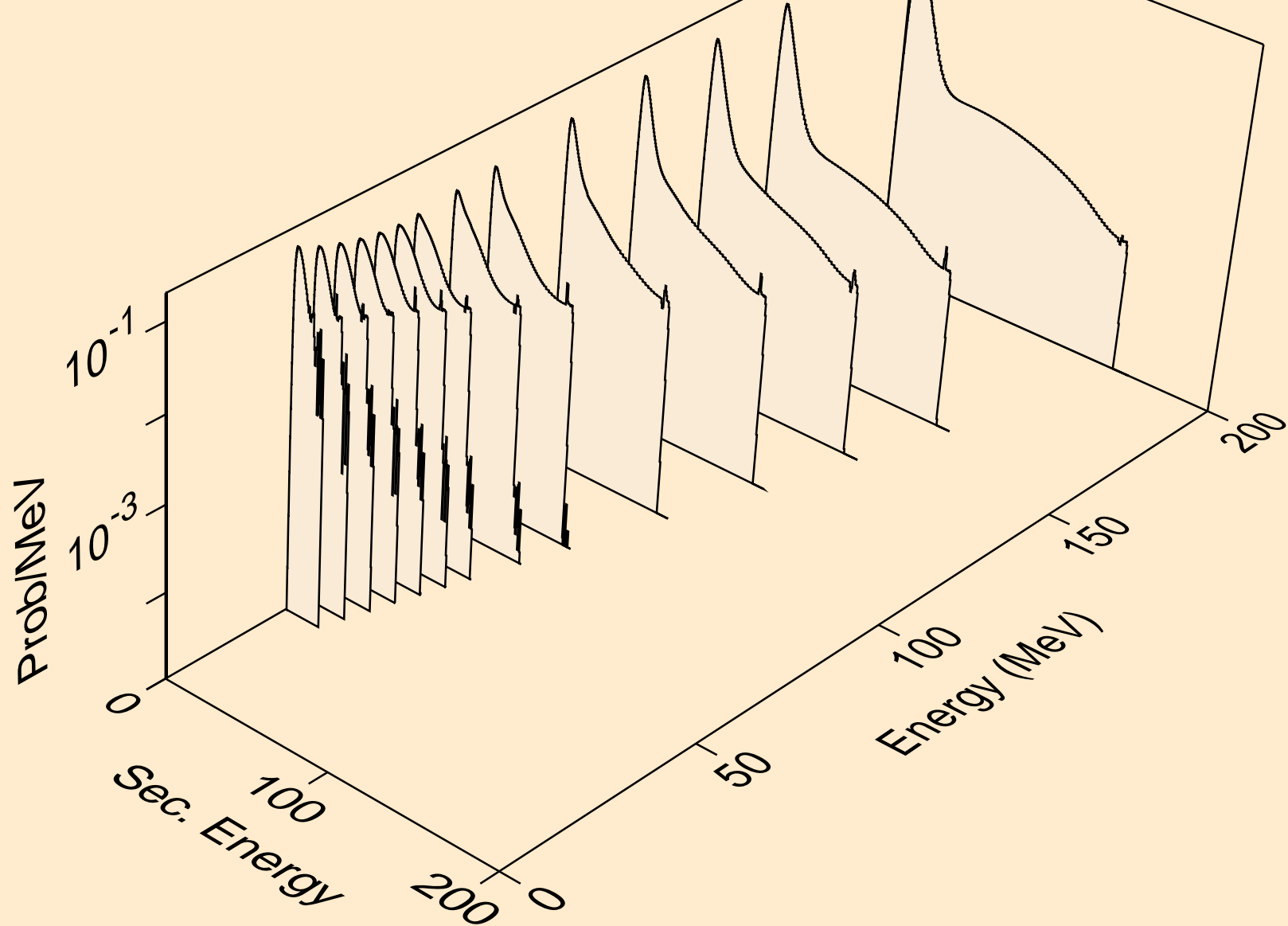

F023 ALPHA ACER TENDL-2024 LIBRARY; T=0.K
tritons from (a,n*)t

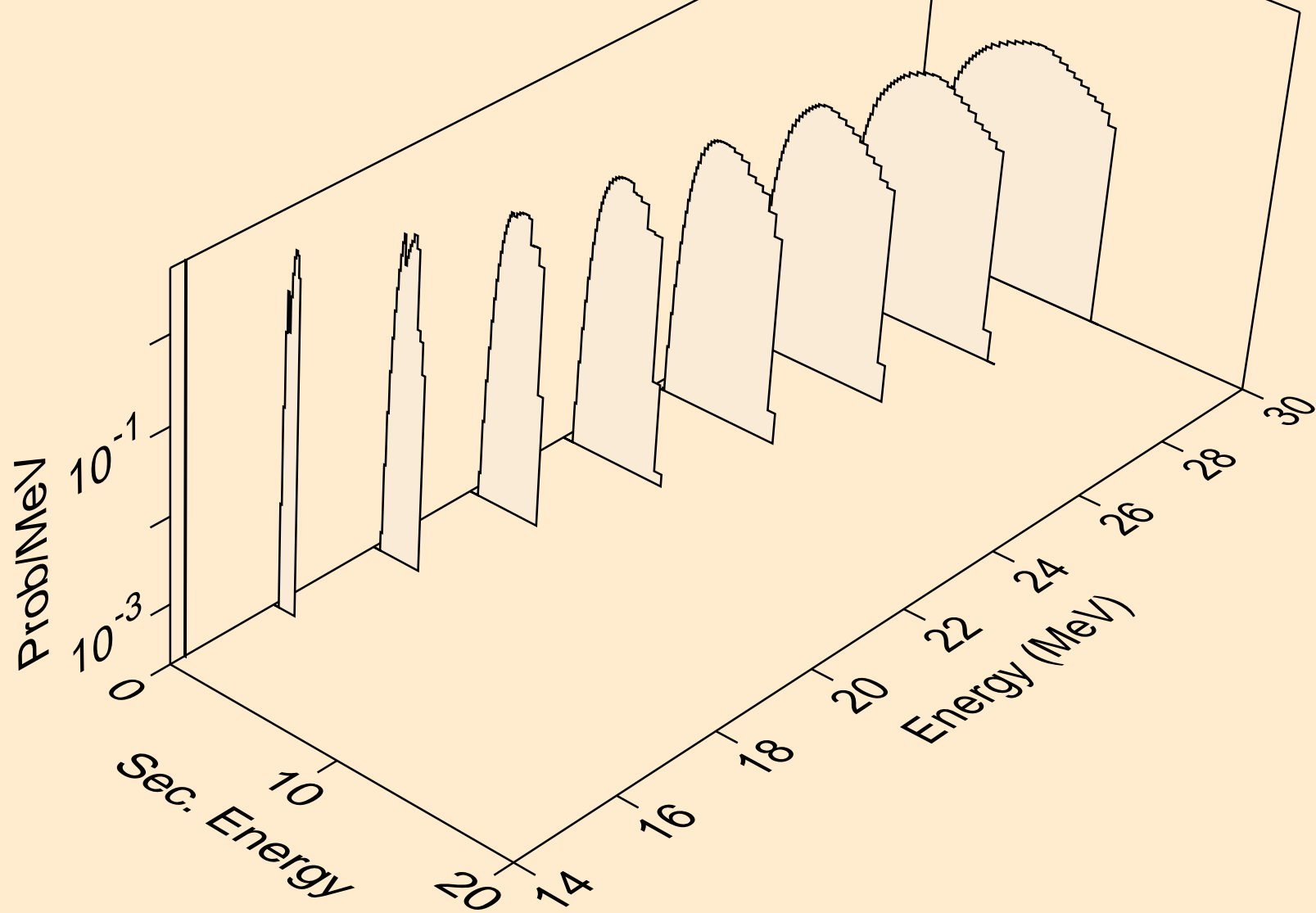

F023 ALPHA ACER TENDL-2024 LIBRARY; T=0.K
tritons from (a,t)

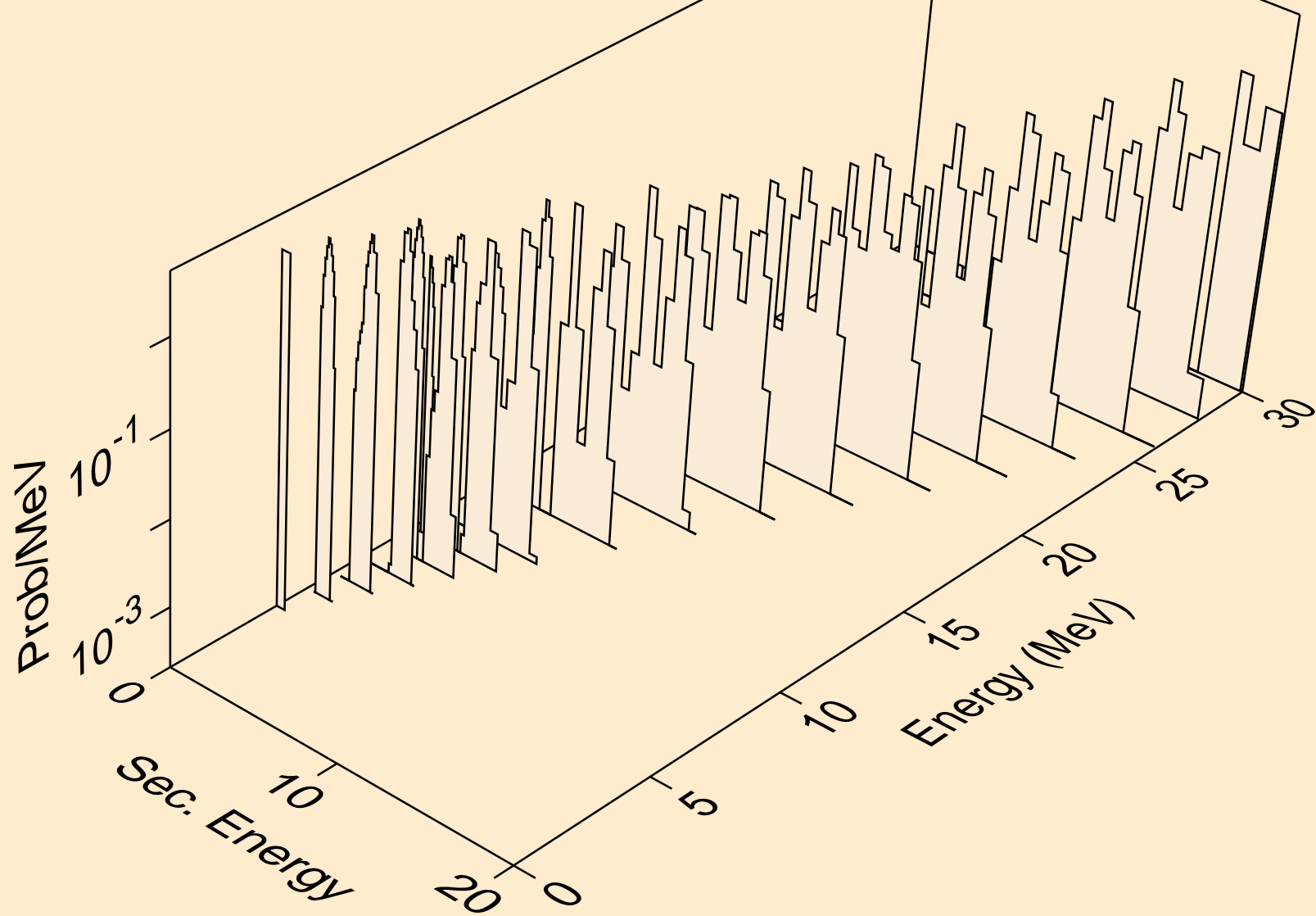

F023 ALPHA ACER TENDL-2024 LIBRARY; T=0.K
tritons from (a,pt)

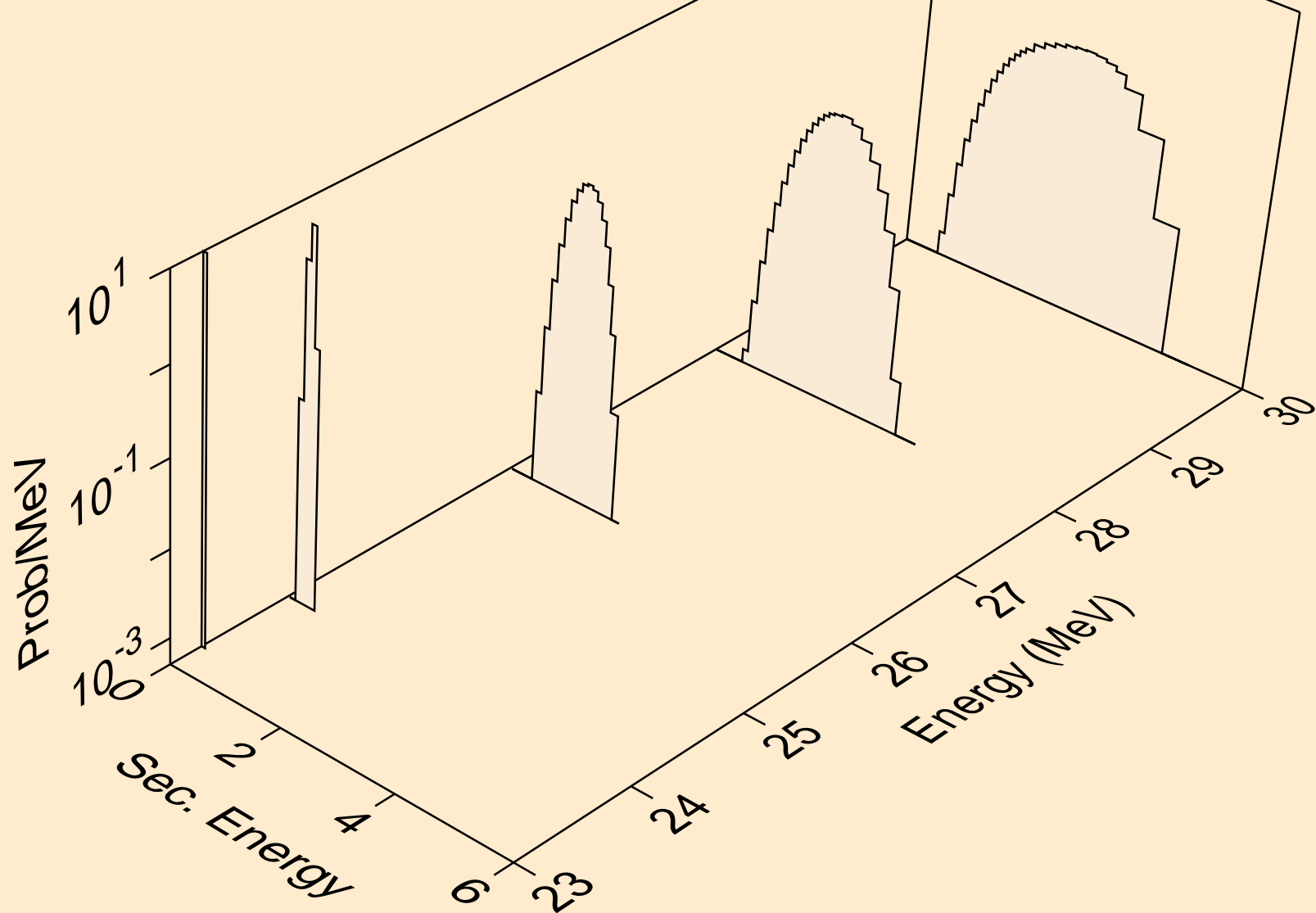

F023 ALPHA ACER TENDL-2024 LIBRARY; T=0.K
he3s from (a,x)

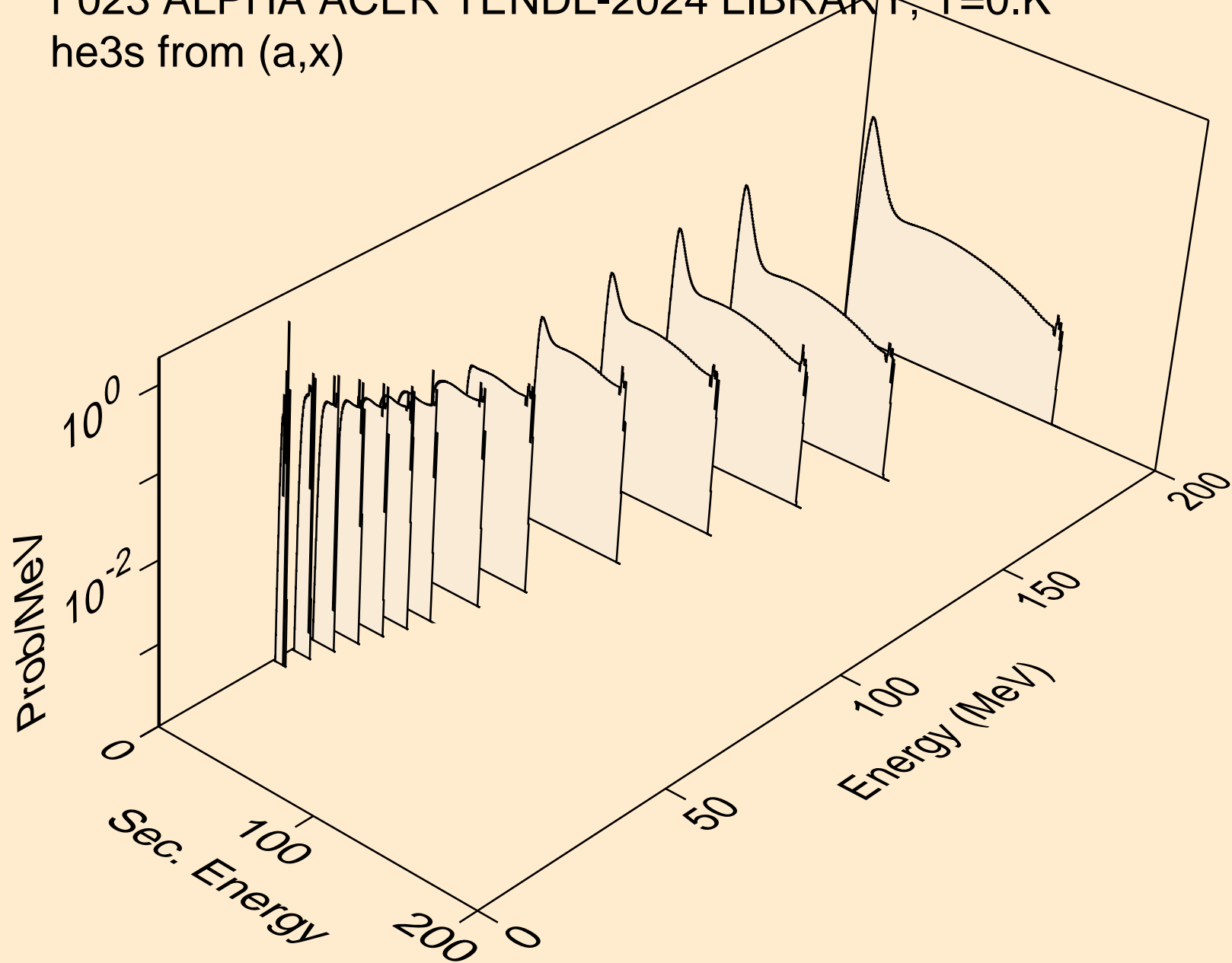

F023 ALPHA ACER TENDL-2024 LIBRARY; T=0.K
he3s from (a,n*)he3

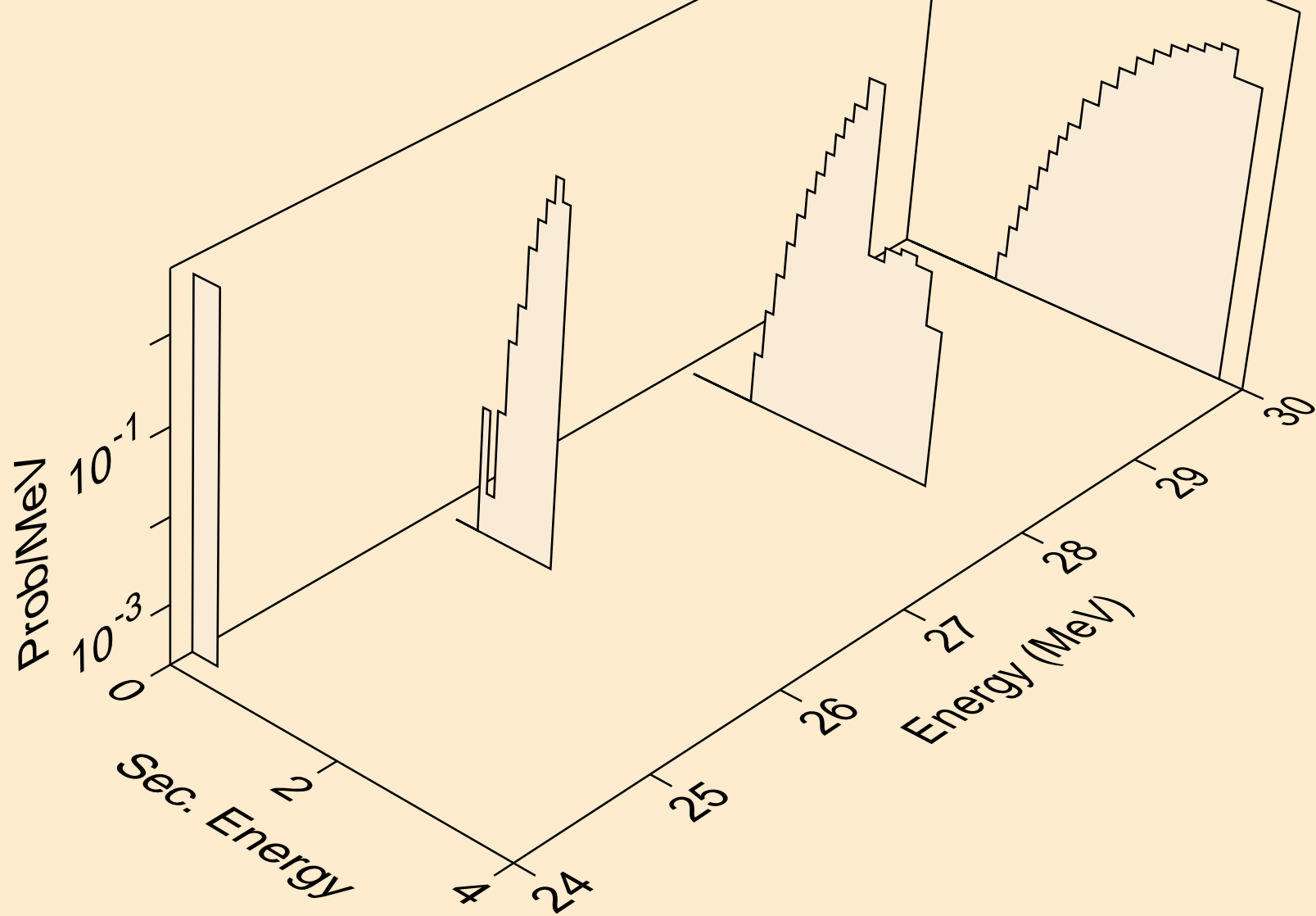

F023 ALPHA ACER TENDL-2024 LIBRARY; T=0.K
he3s from (a,he3)

