

IR190 ALPHA ACER TENDL-2024 LIBRARY; T=0.K
Principal cross sections

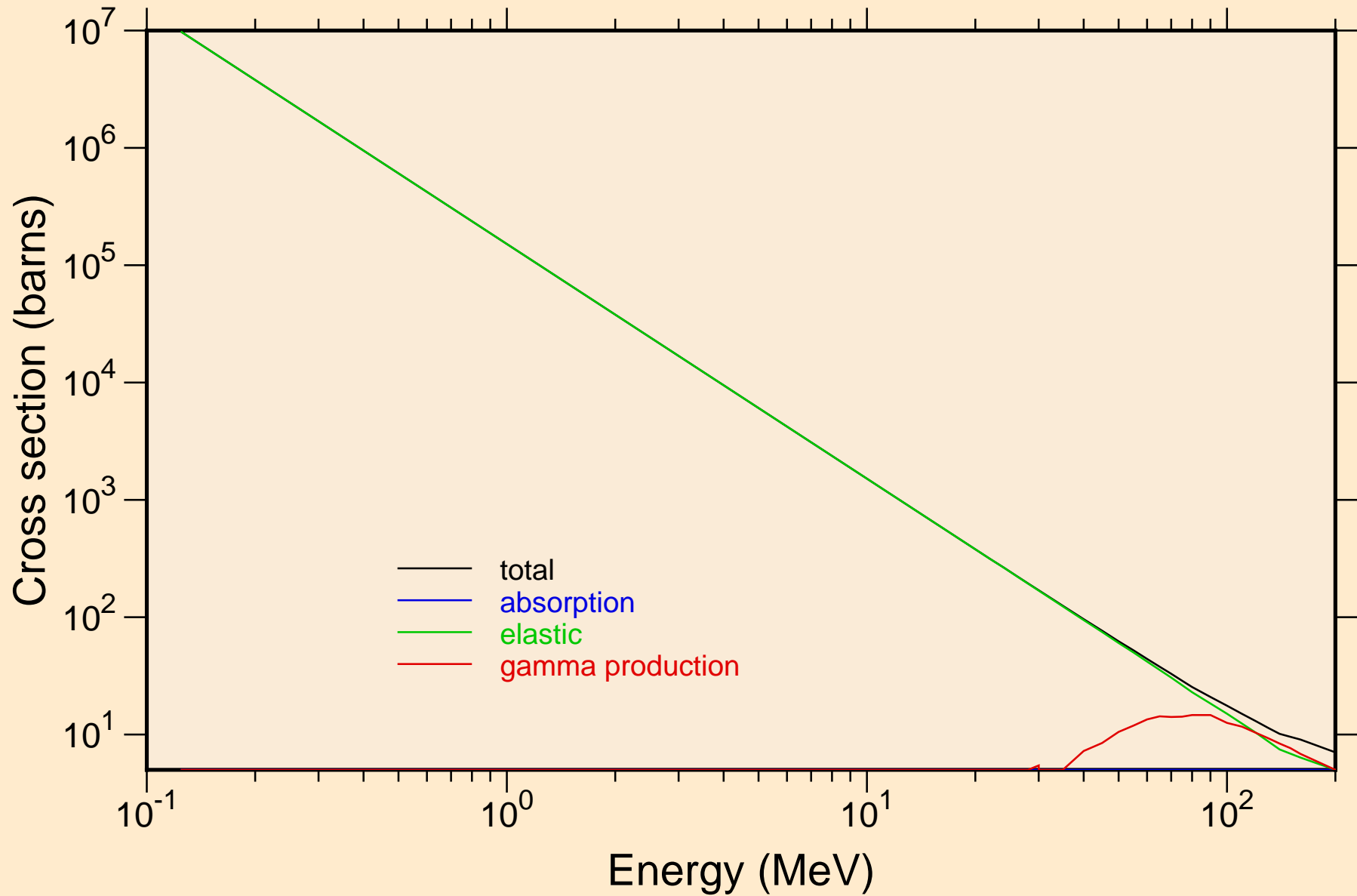

IR190 ALPHA ACER TENDL-2024 LIBRARY; T=0.K
Heating

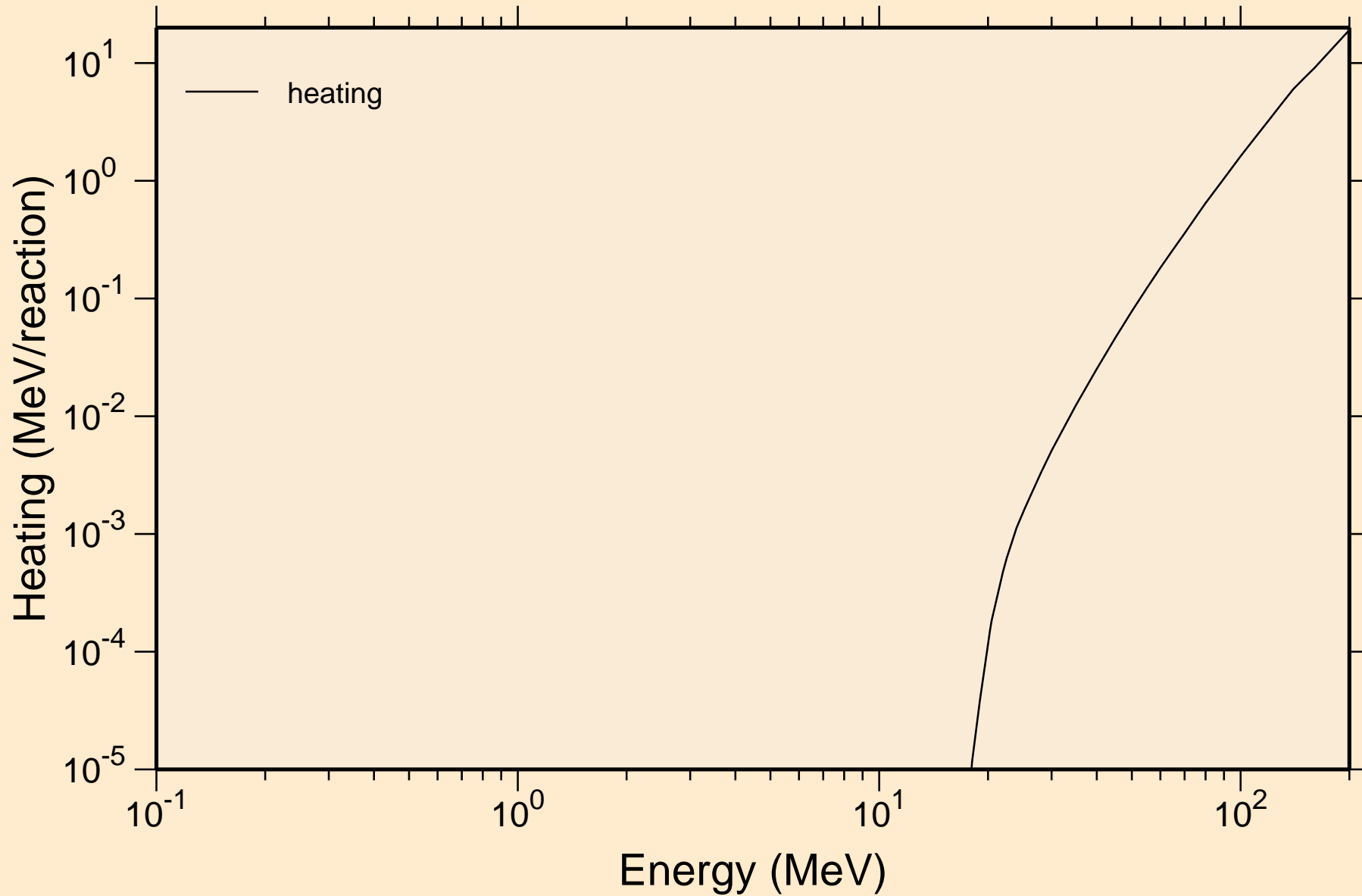

IR190 ALPHA ACER TENDL-2024 LIBRARY; T=0.K

Principal cross sections

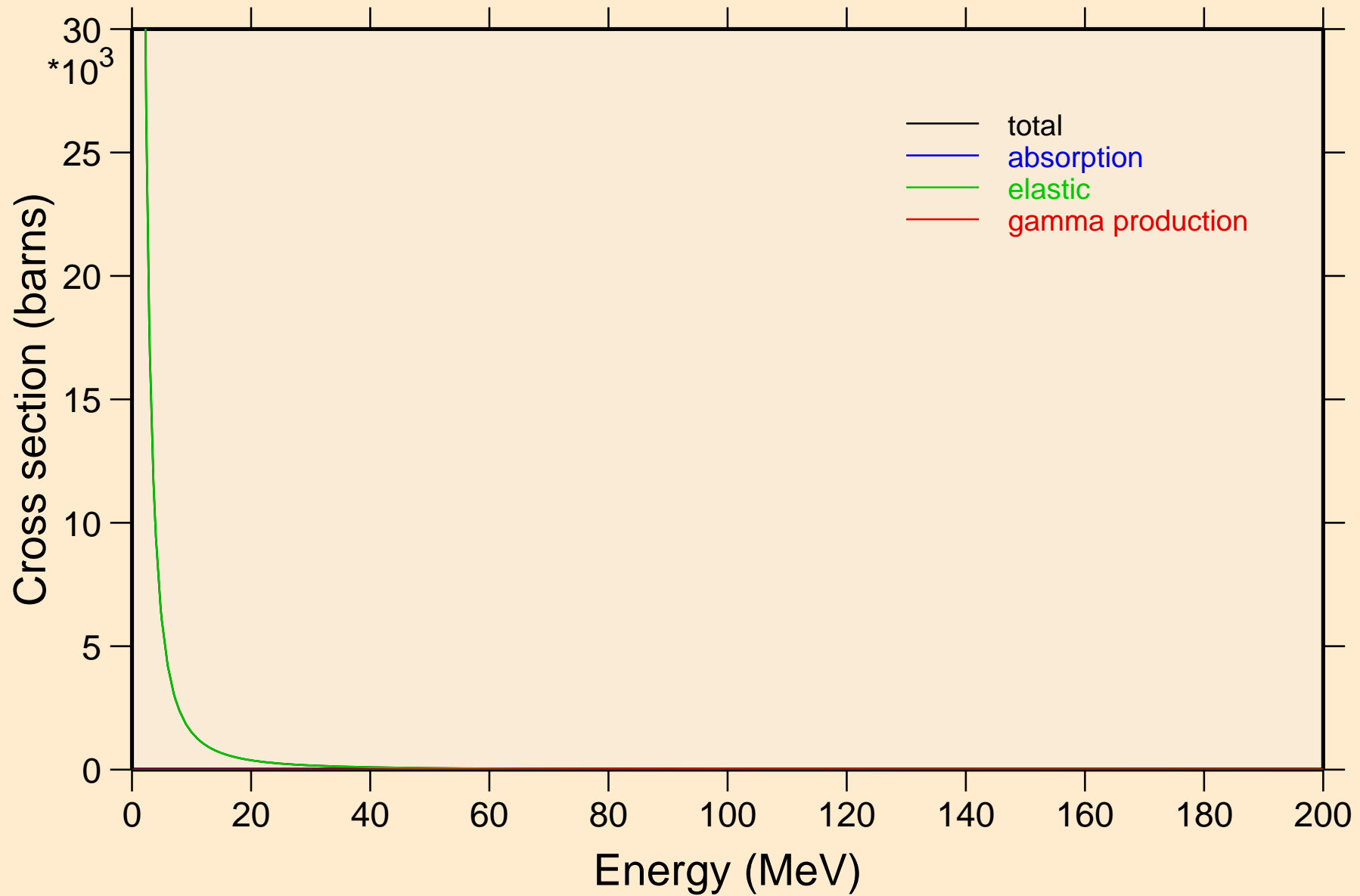

IR190 ALPHA ACER TENDL-2024 LIBRARY; T=0.K

Heating

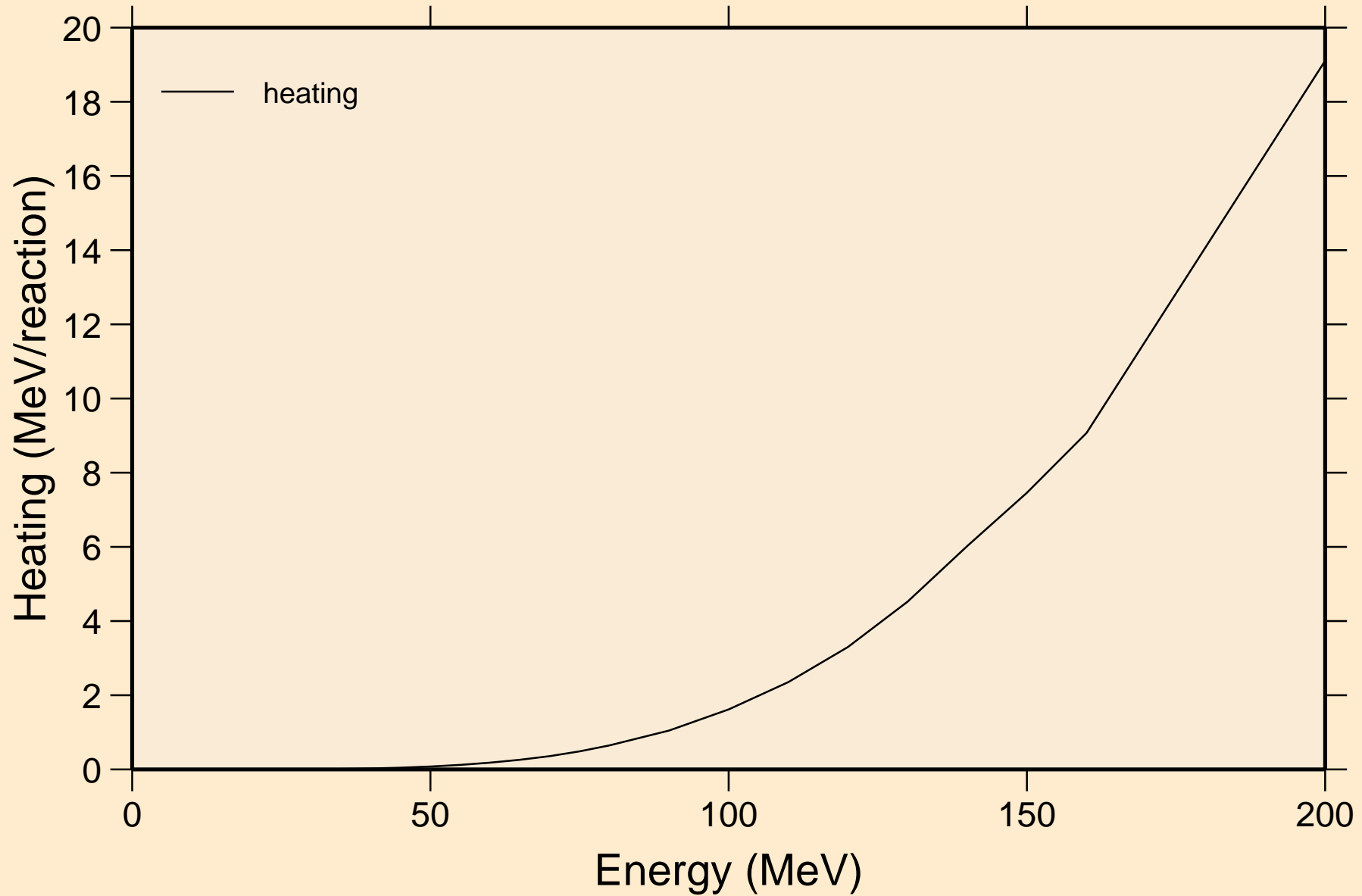

IR190 ALPHA ACER TENDL-2024 LIBRARY; T=0.K
Threshold reactions

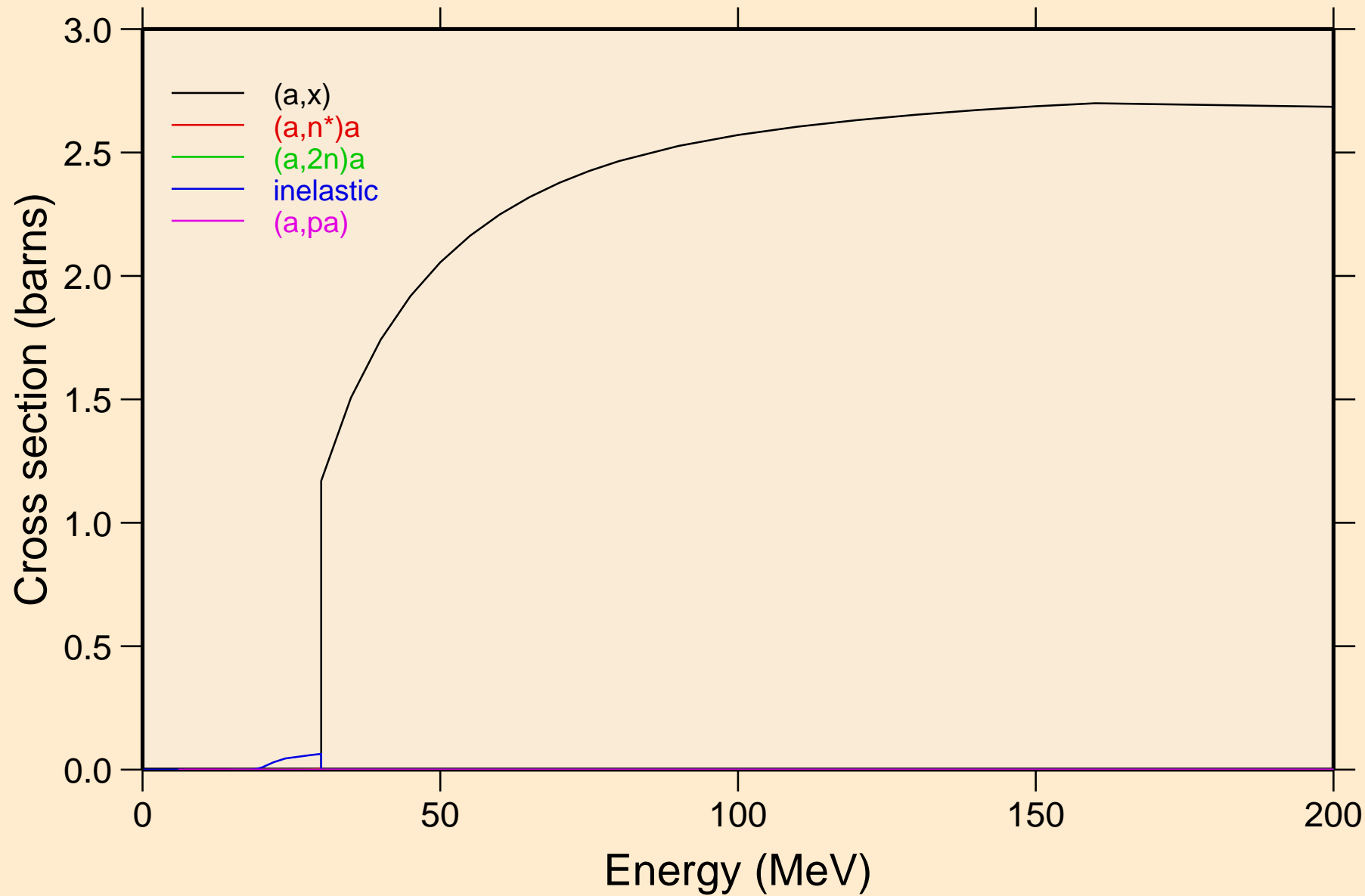

IR190 ALPHA ACER TENDL-2024 LIBRARY; T=0.K
angular distribution for elastic

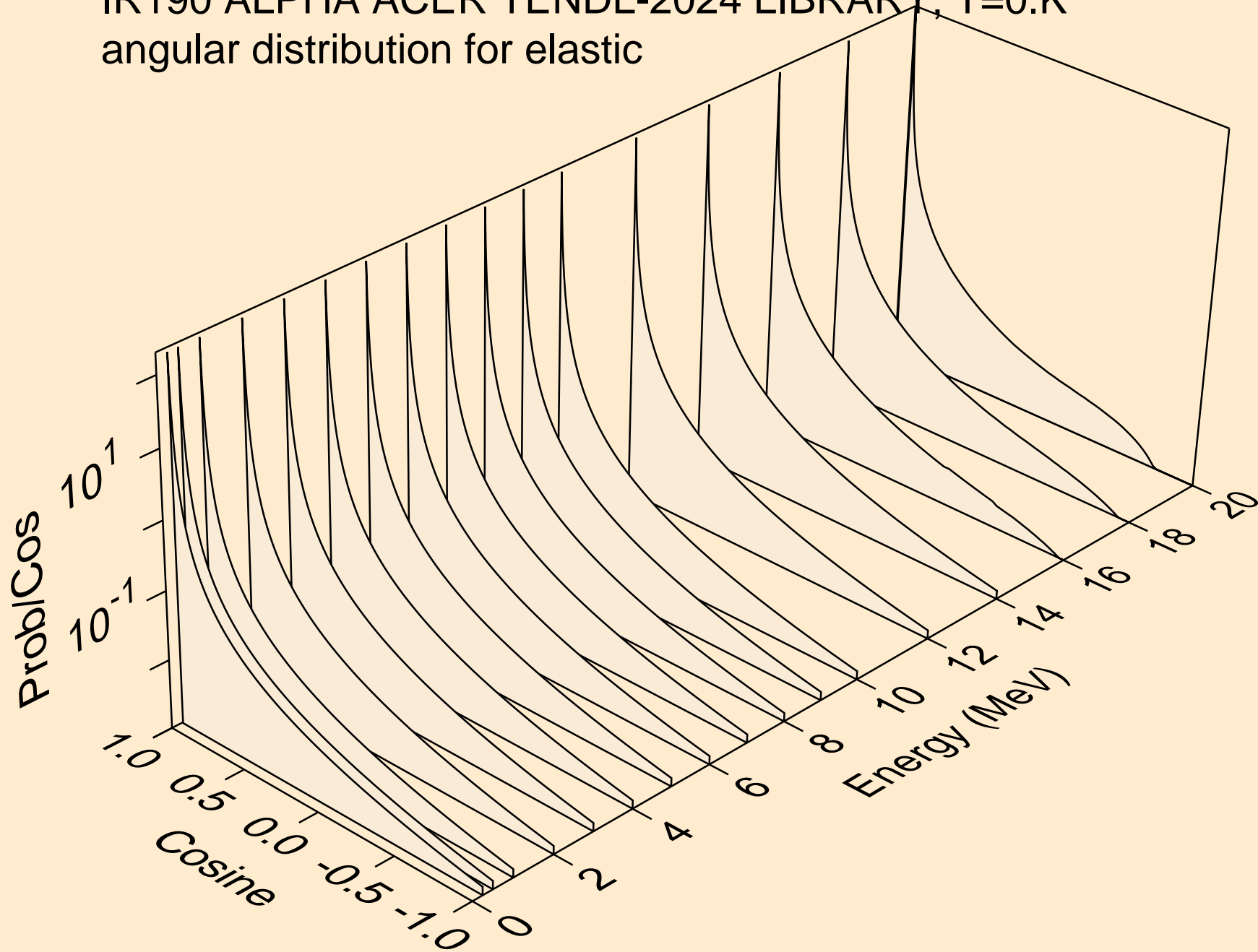

IR190 ALPHA ACER TENDL-2024 LIBRARY; T=0.K
angular distribution for elastic

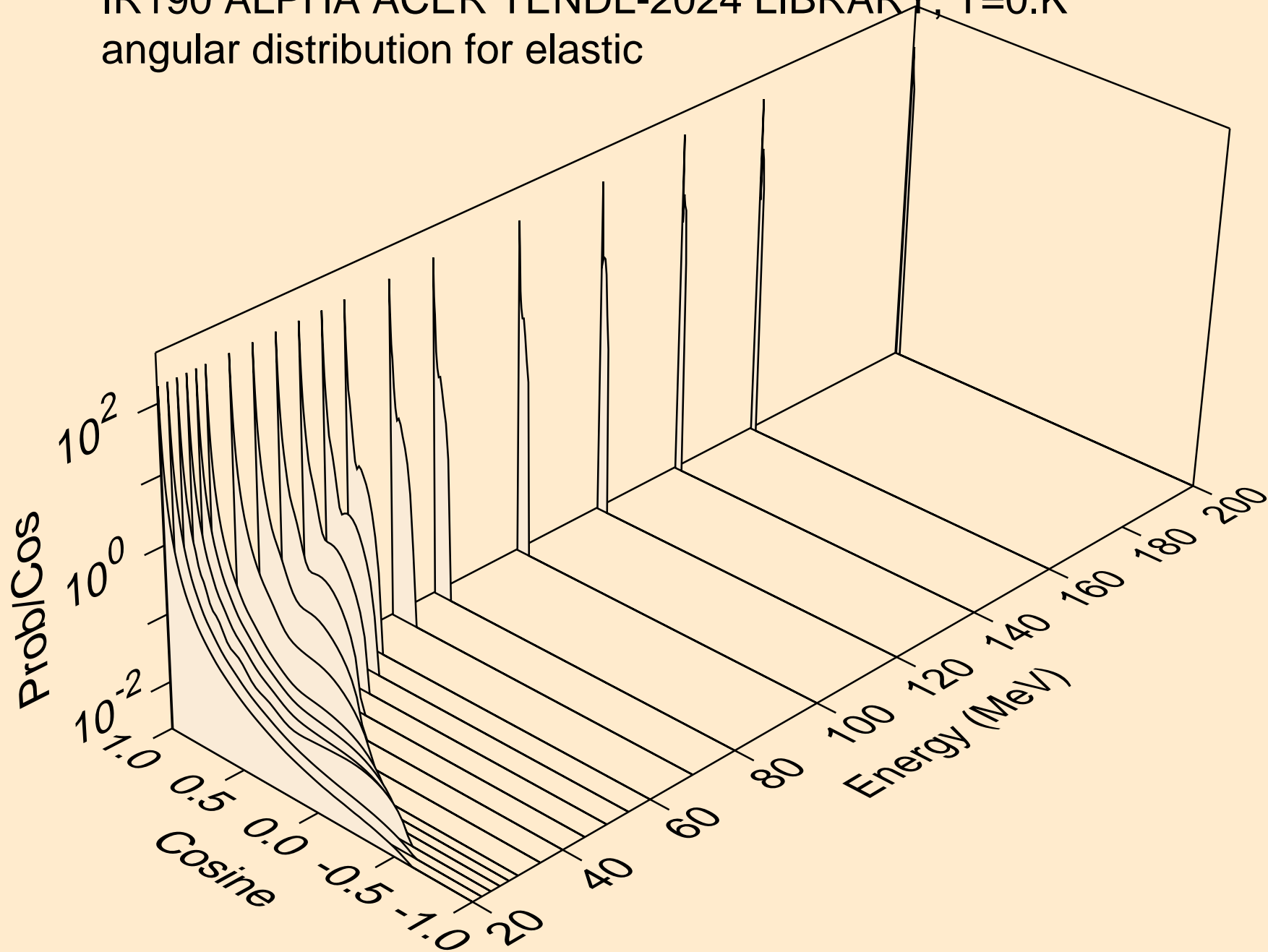

IR190 ALPHA ACER TENDL-2024 LIBRARY; T=0.K
Alpha emission for (a,x)

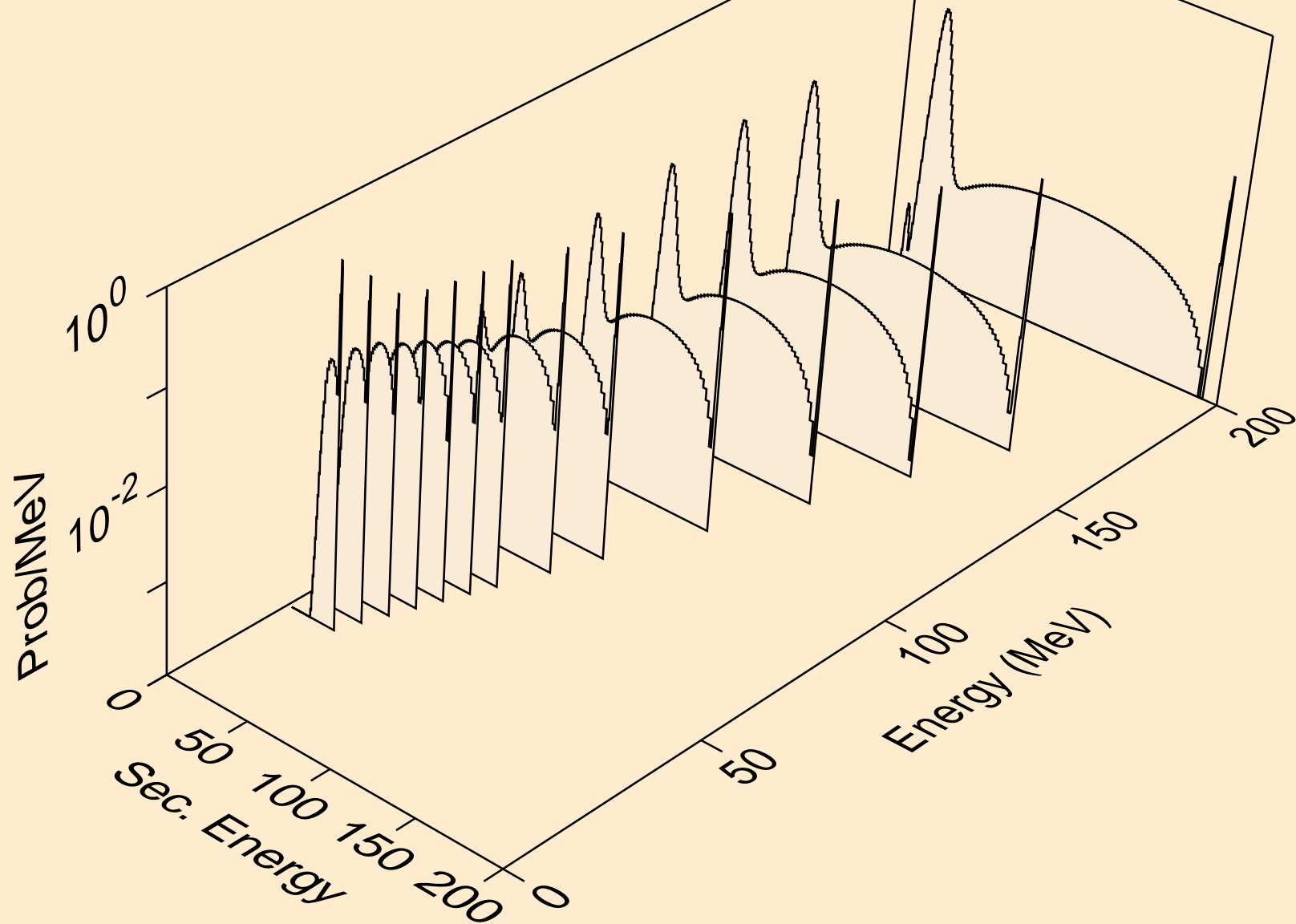

IR190 ALPHA ACER TENDL-2024 LIBRARY; T=0.K
Alpha emission for (a,n*)a

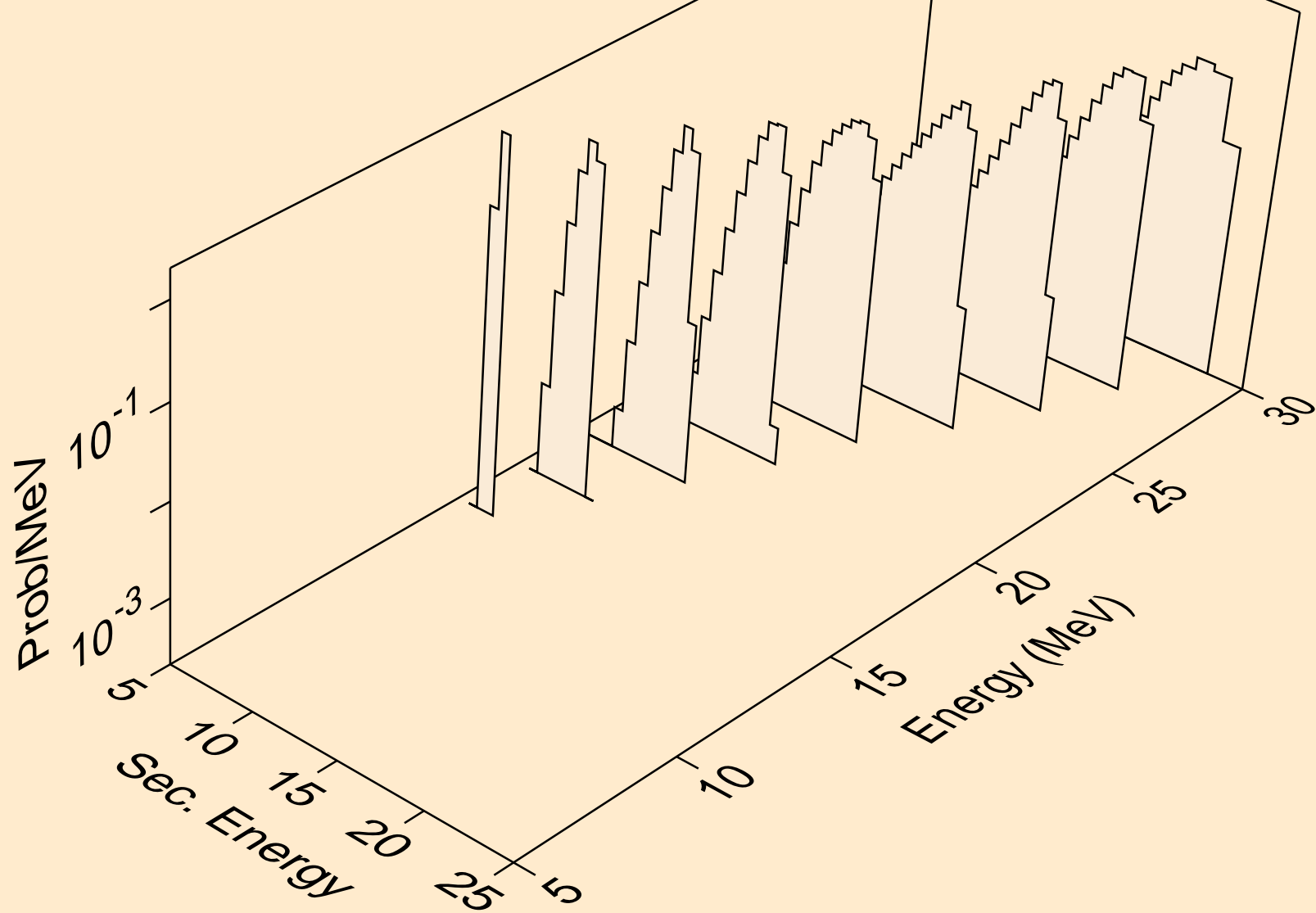

IR190 ALPHA ACER TENDL-2024 LIBRARY; T=0.K
Alpha emission for (a,2n)a

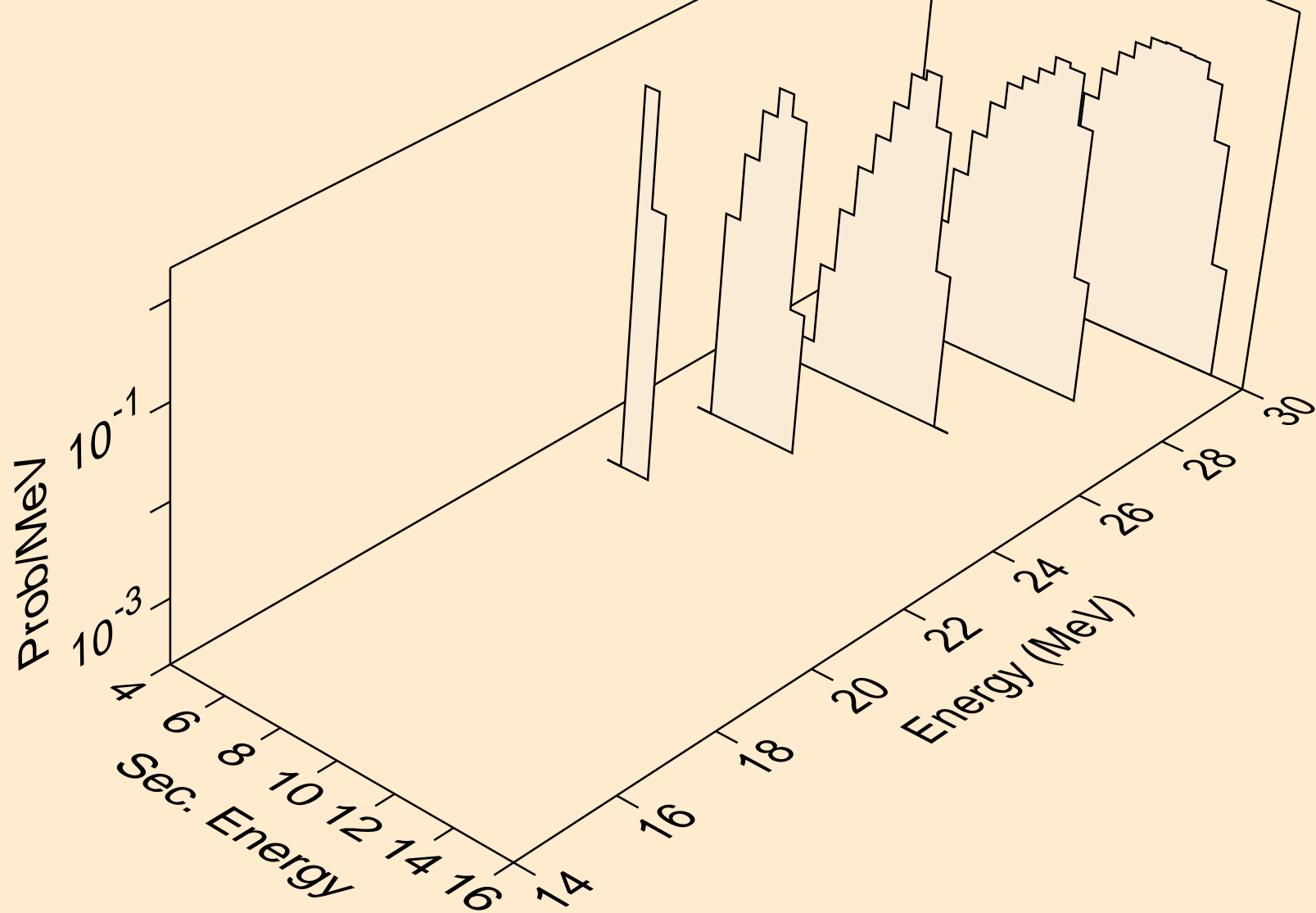

IR190 ALPHA ACER TENDL-2024 LIBRARY; T=0.K
Alpha emission for inelastic

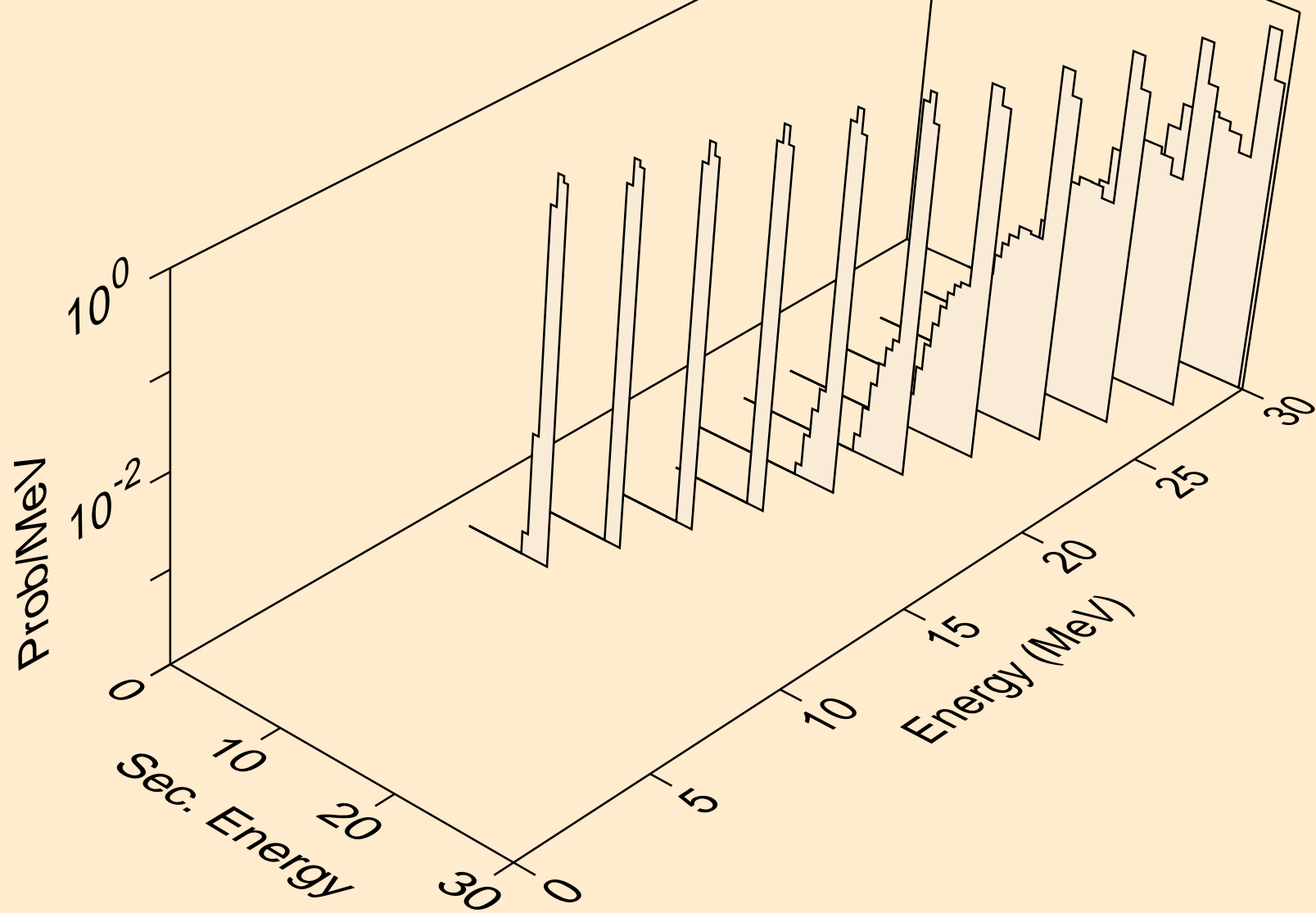

IR190 ALPHA ACER TENDL-2024 LIBRARY; T=0.K
Alpha emission for (a,pa)

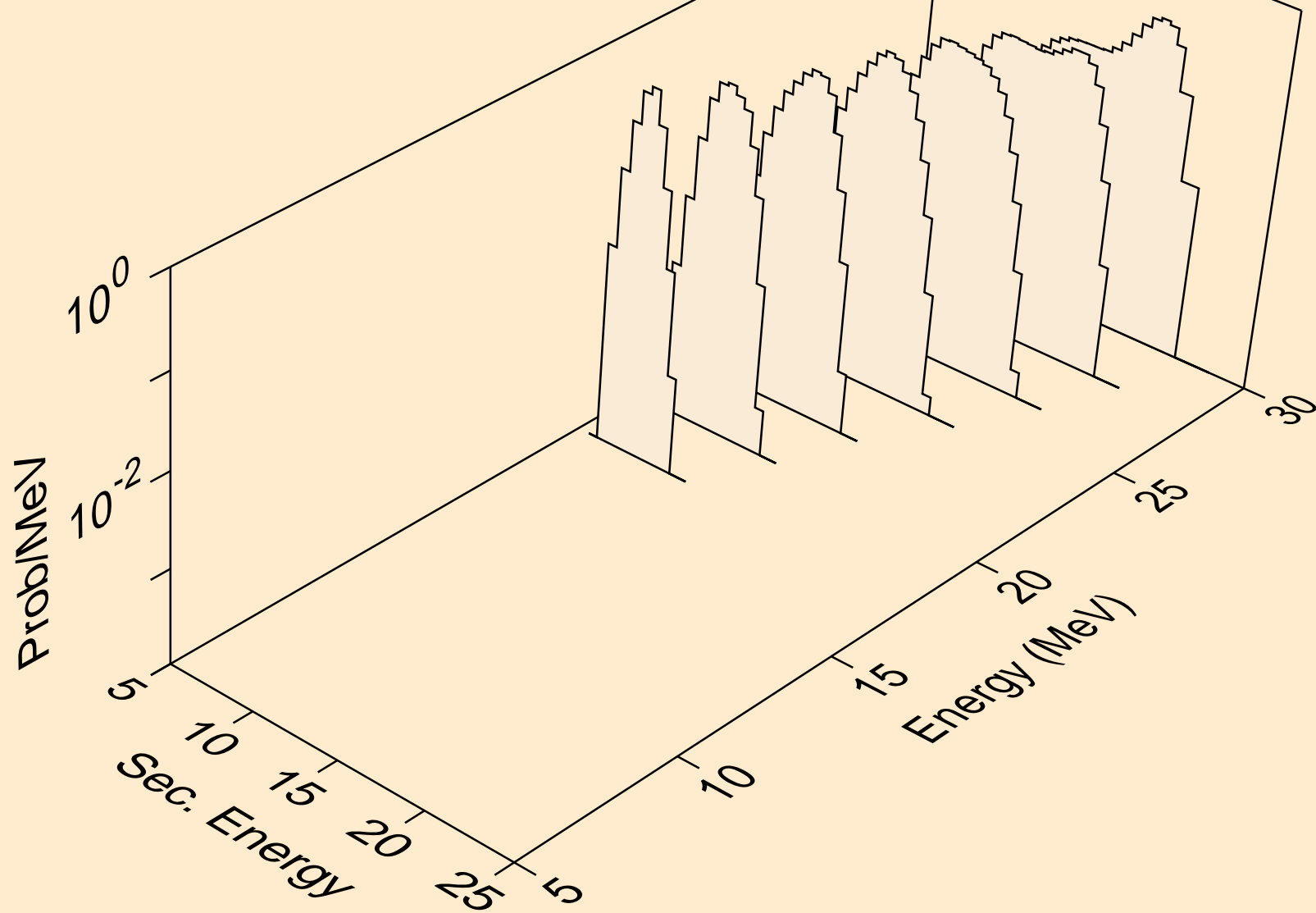

IR190 ALPHA ACER TENDL-2024 LIBRARY; T=0.K
Photon emission for (z,n)

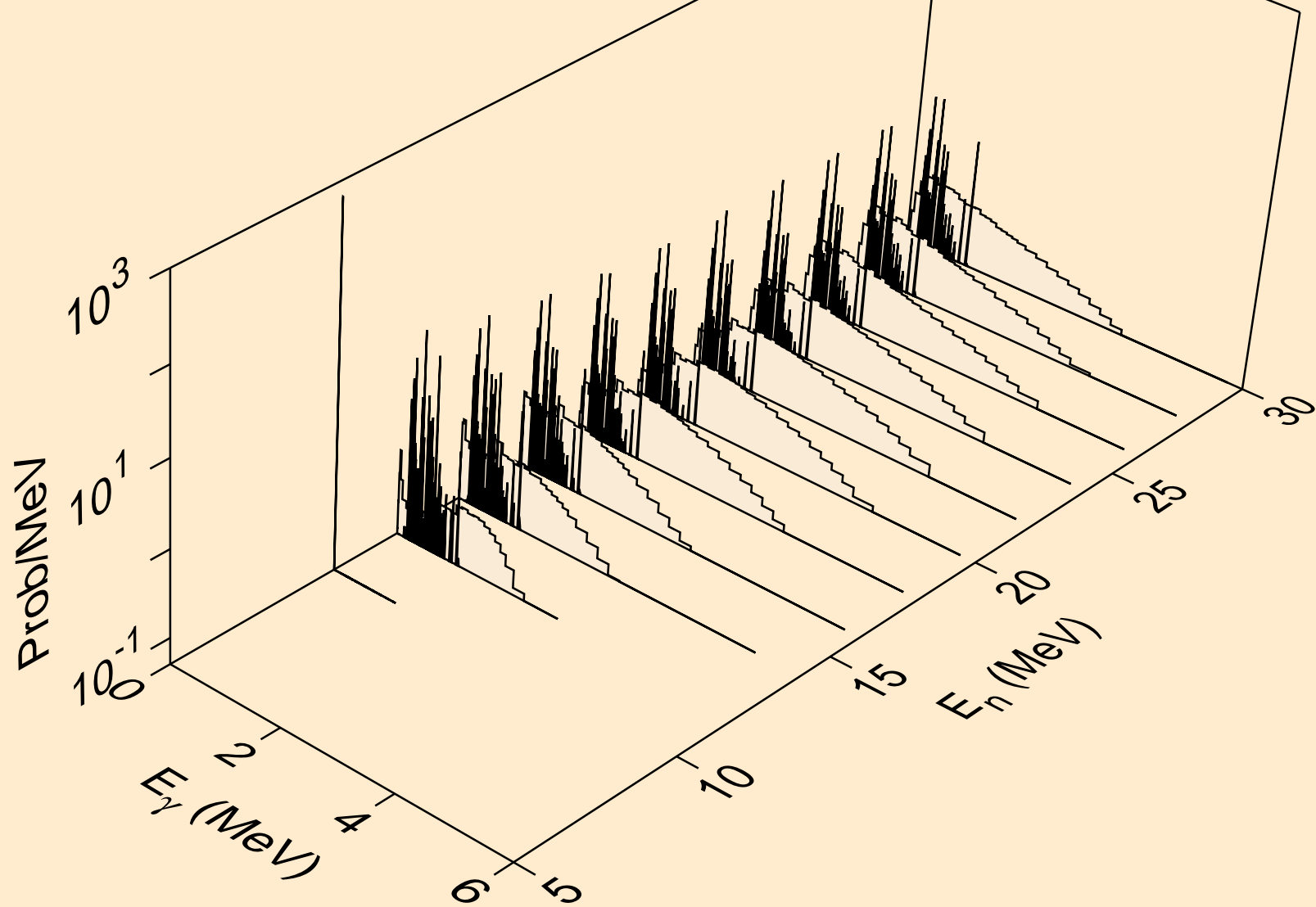

IR190 ALPHA ACER TENDL-2024 LIBRARY; T=0.K
Photon emission for (z,x)

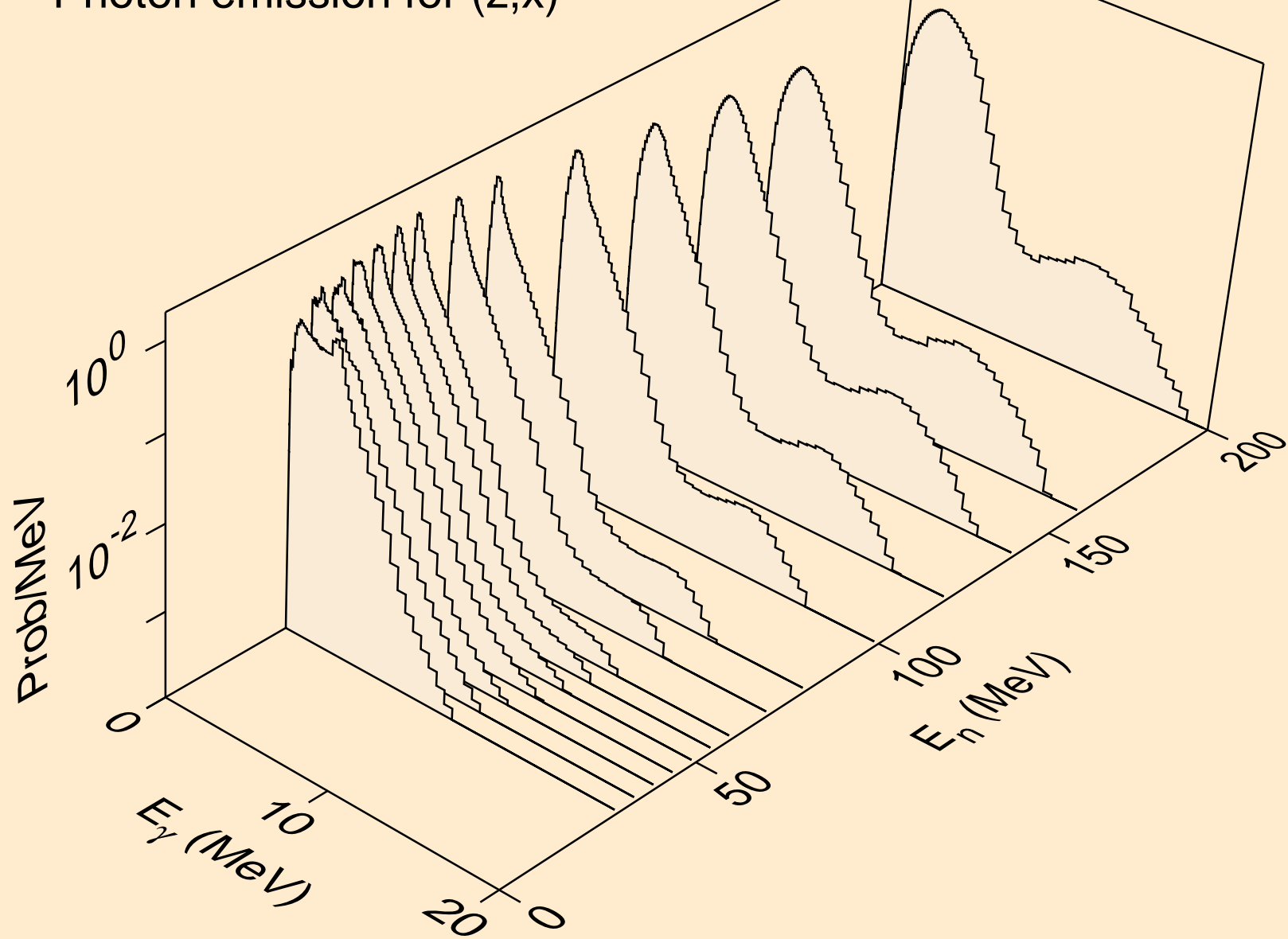

IR190 ALPHA ACER TENDL-2024 LIBRARY; T=0.K
Photon emission for (n,2n)

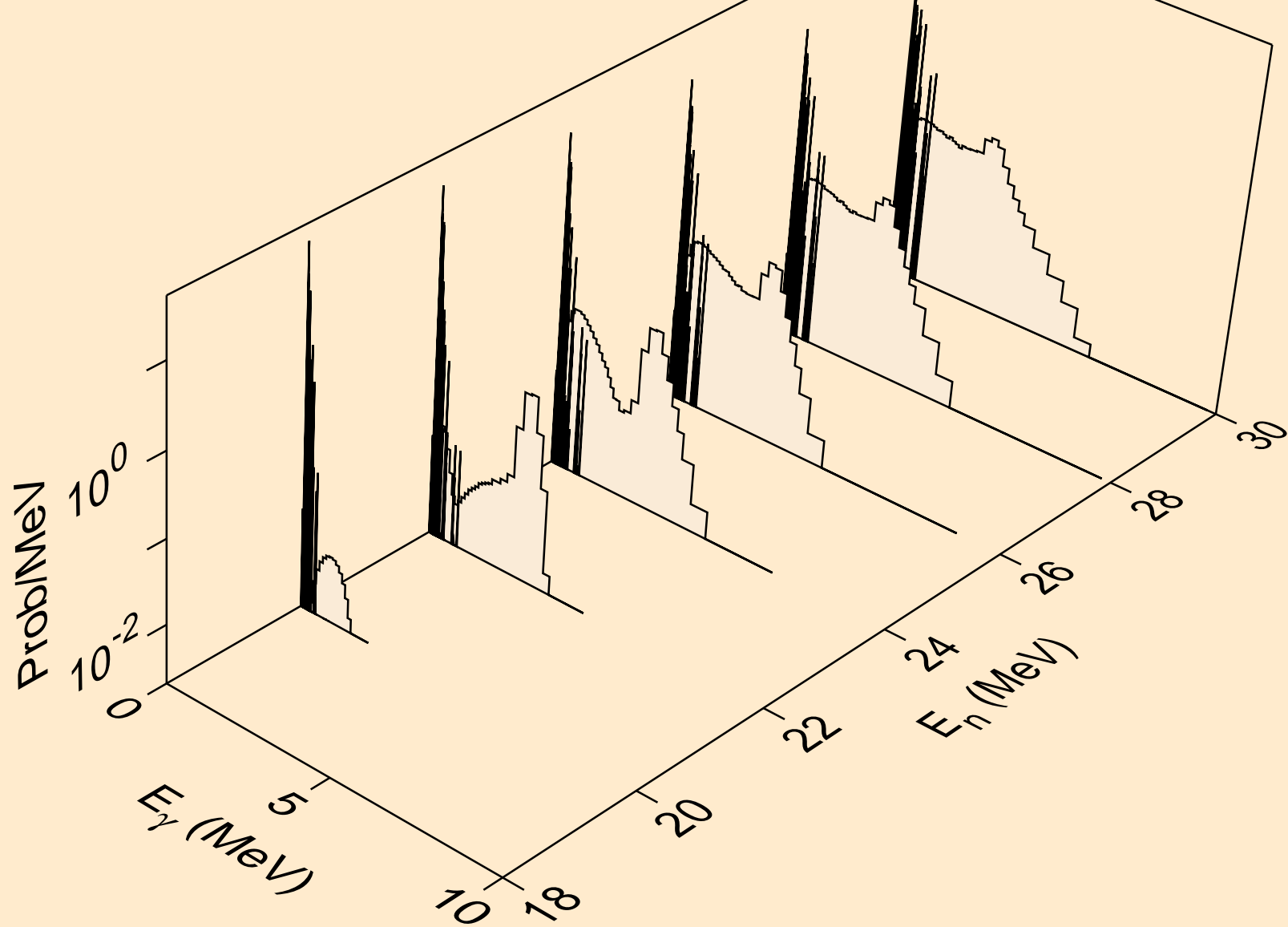

IR190 ALPHA ACER TENDL-2024 LIBRARY; T=0.K
Photon emission for (n,3n)

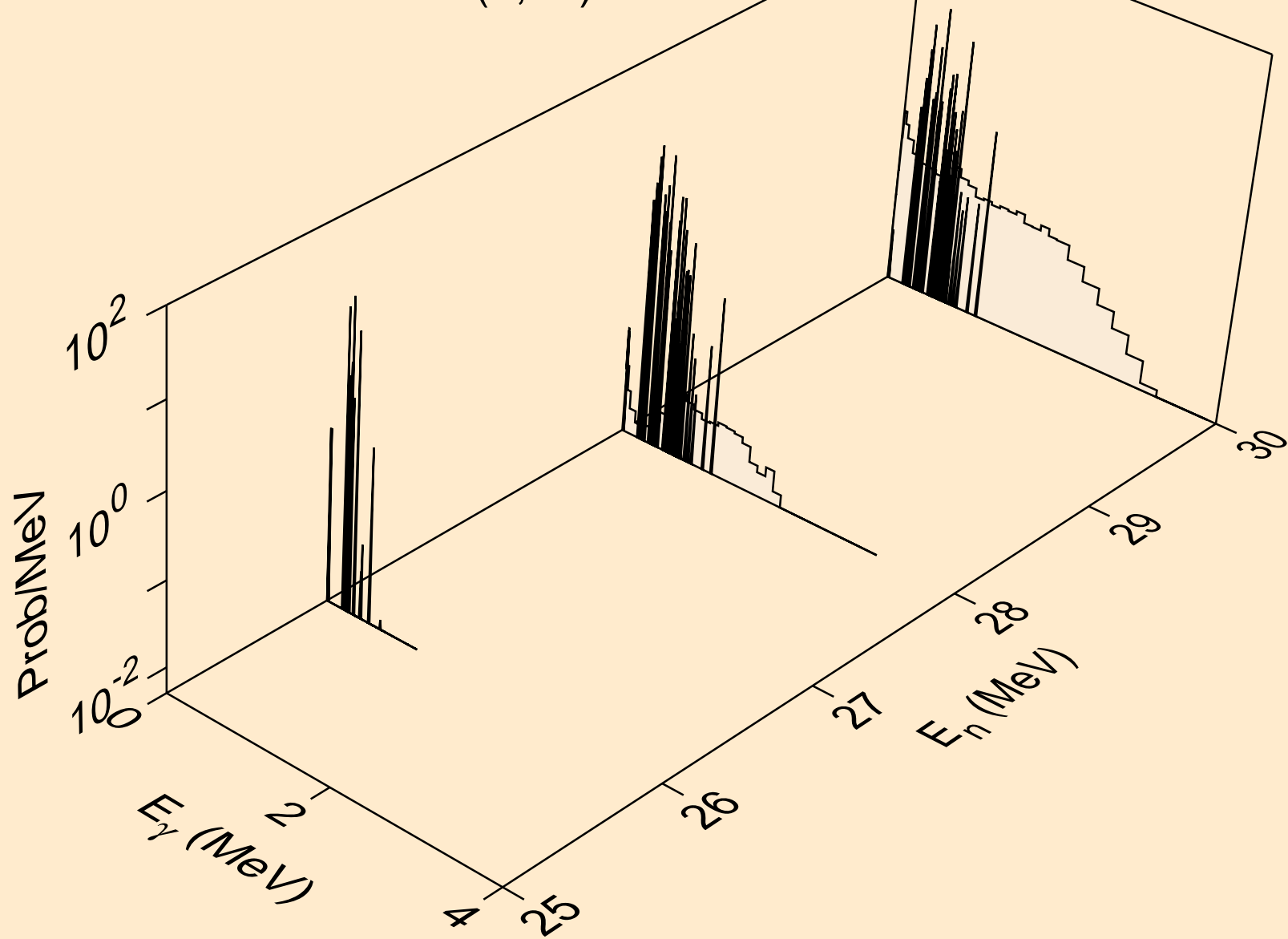

IR190 ALPHA ACER TENDL-2024 LIBRARY; T=0.K
Photon emission for (n,n*)a

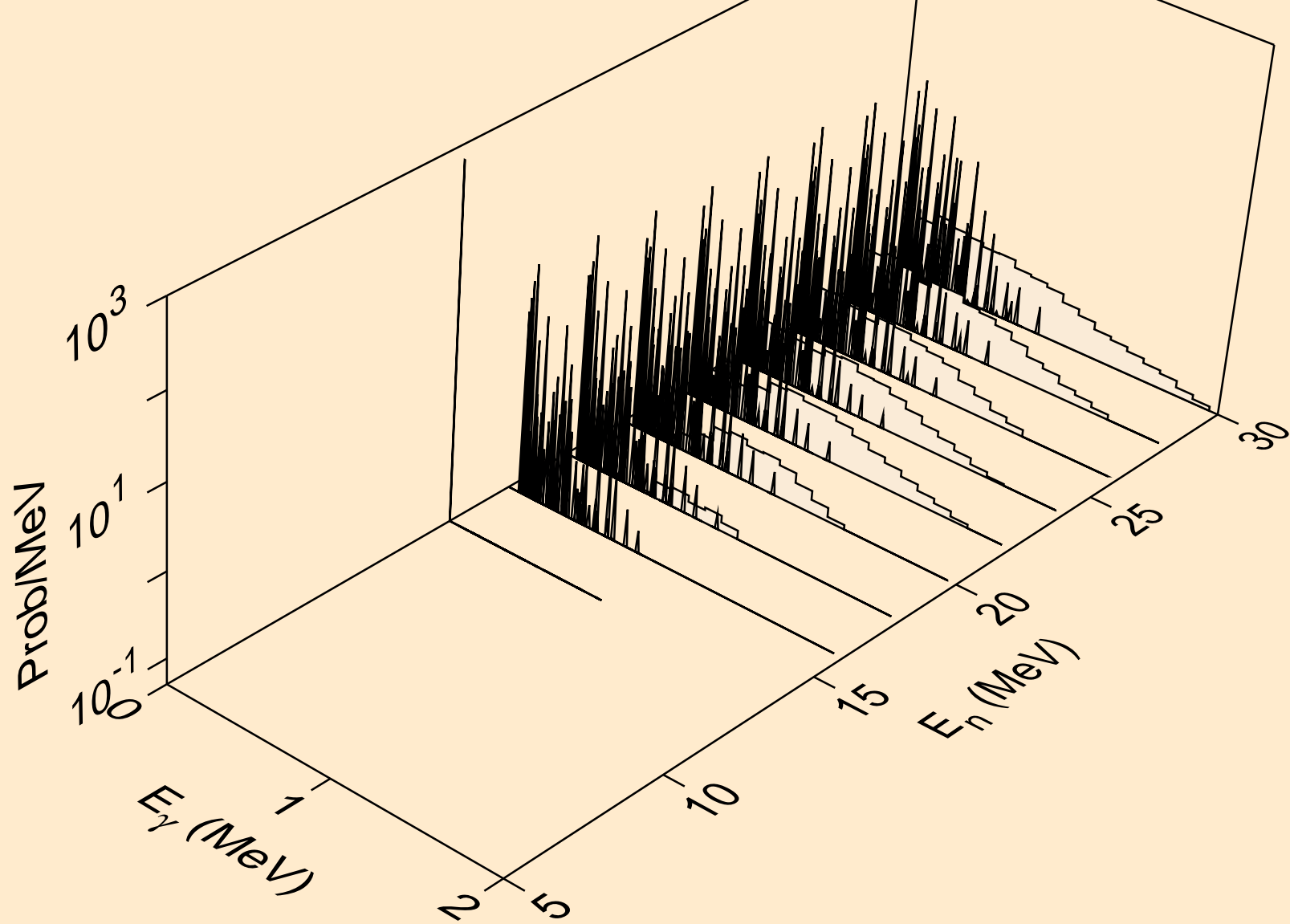

IR190 ALPHA ACER TENDL-2024 LIBRARY; T=0.K
Photon emission for (n,2n)a

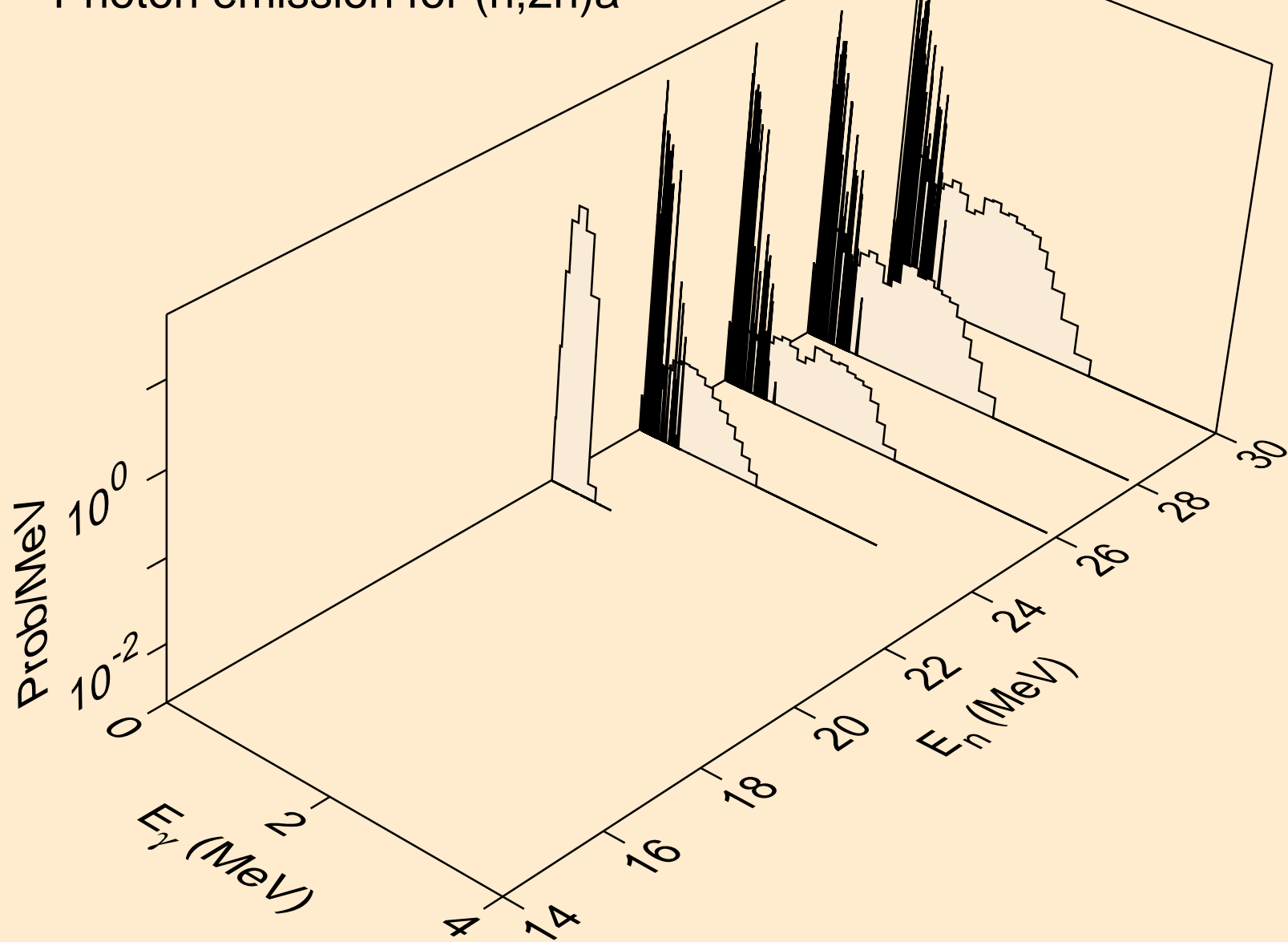

IR190 ALPHA ACER TENDL-2024 LIBRARY; T=0.K
Photon emission for (n,n*)p

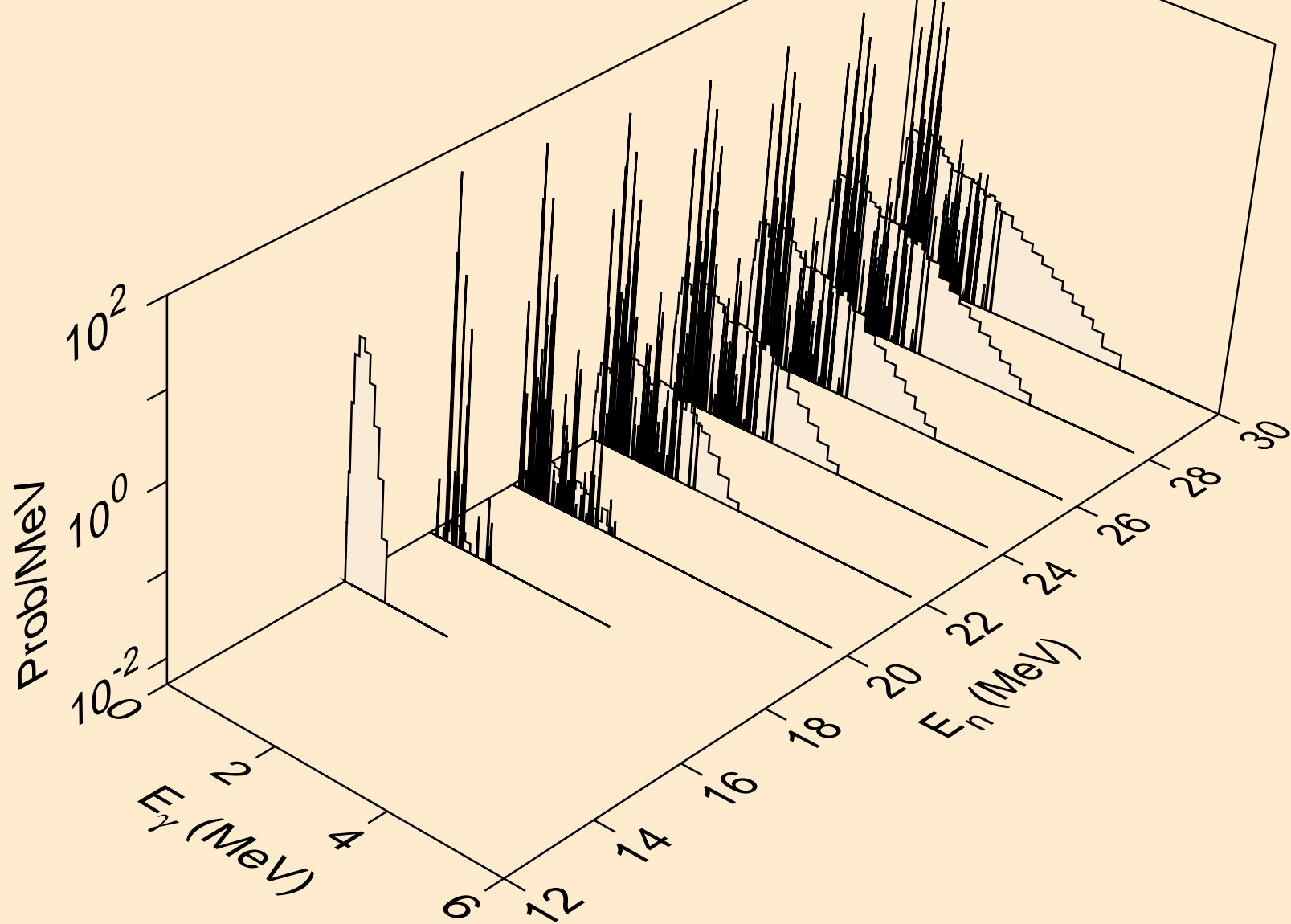

IR190 ALPHA ACER TENDL-2024 LIBRARY; T=0.K
Photon emission for (n,n*)d

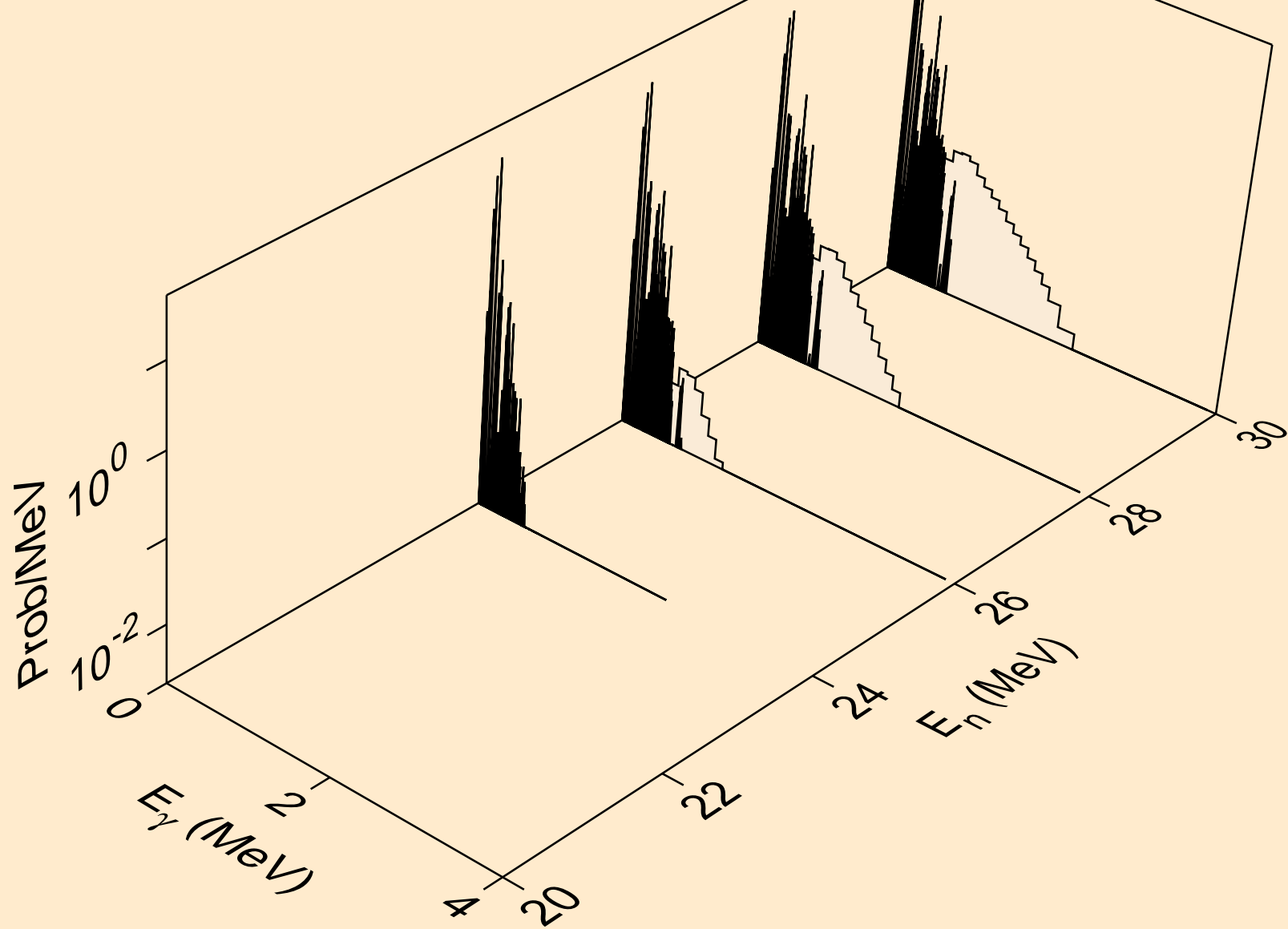

IR190 ALPHA ACER TENDL-2024 LIBRARY; T=0.K
Photon emission for (n,n*)t

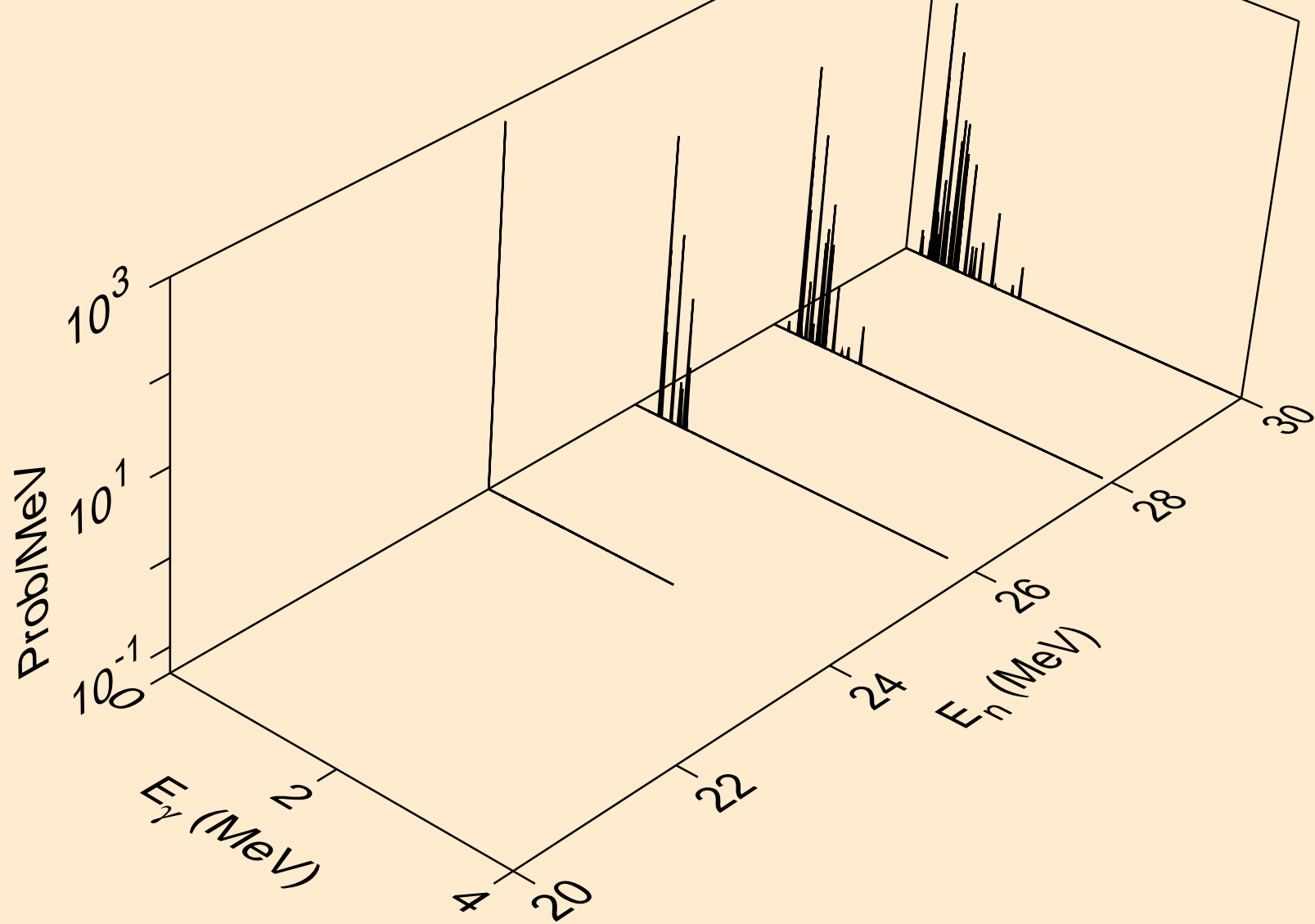

IR190 ALPHA ACER TENDL-2024 LIBRARY; T=0.K
Photon emission for (n,2np)

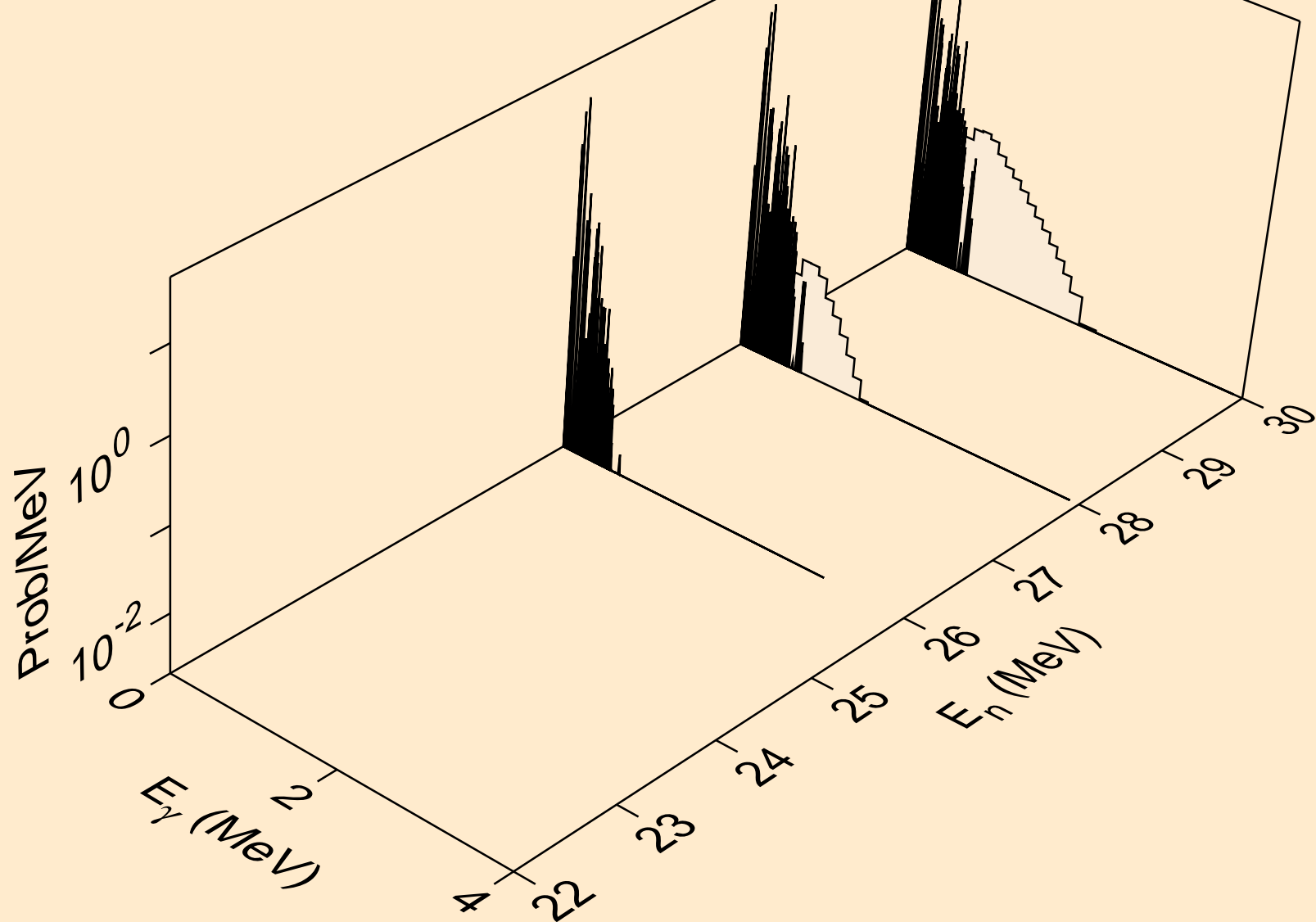

IR190 ALPHA ACER TENDL-2024 LIBRARY; T=0.K
Photon emission for (n,gma)

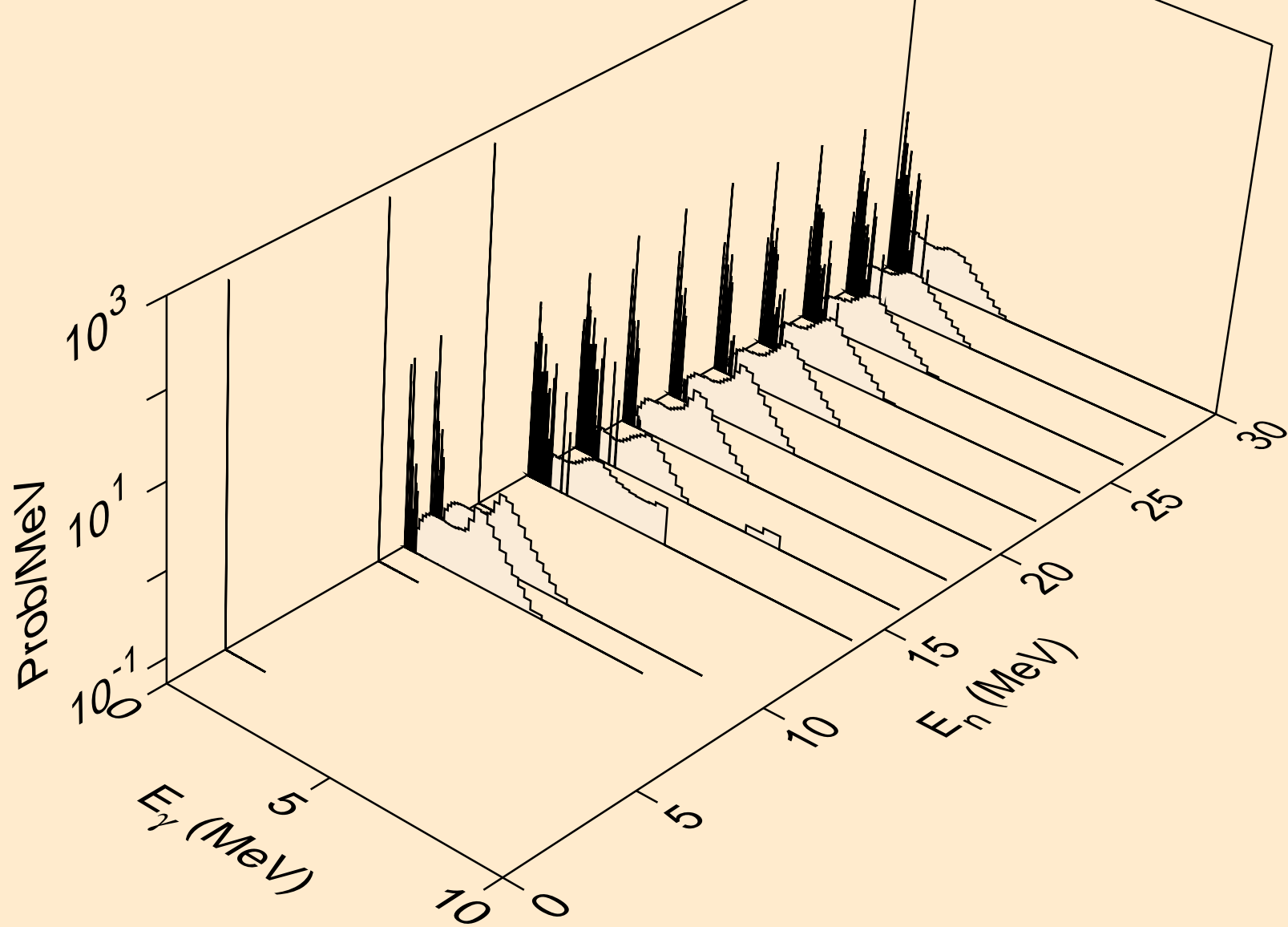

IR190 ALPHA ACER TENDL-2024 LIBRARY; T=0.K
Photon emission for (n,p)

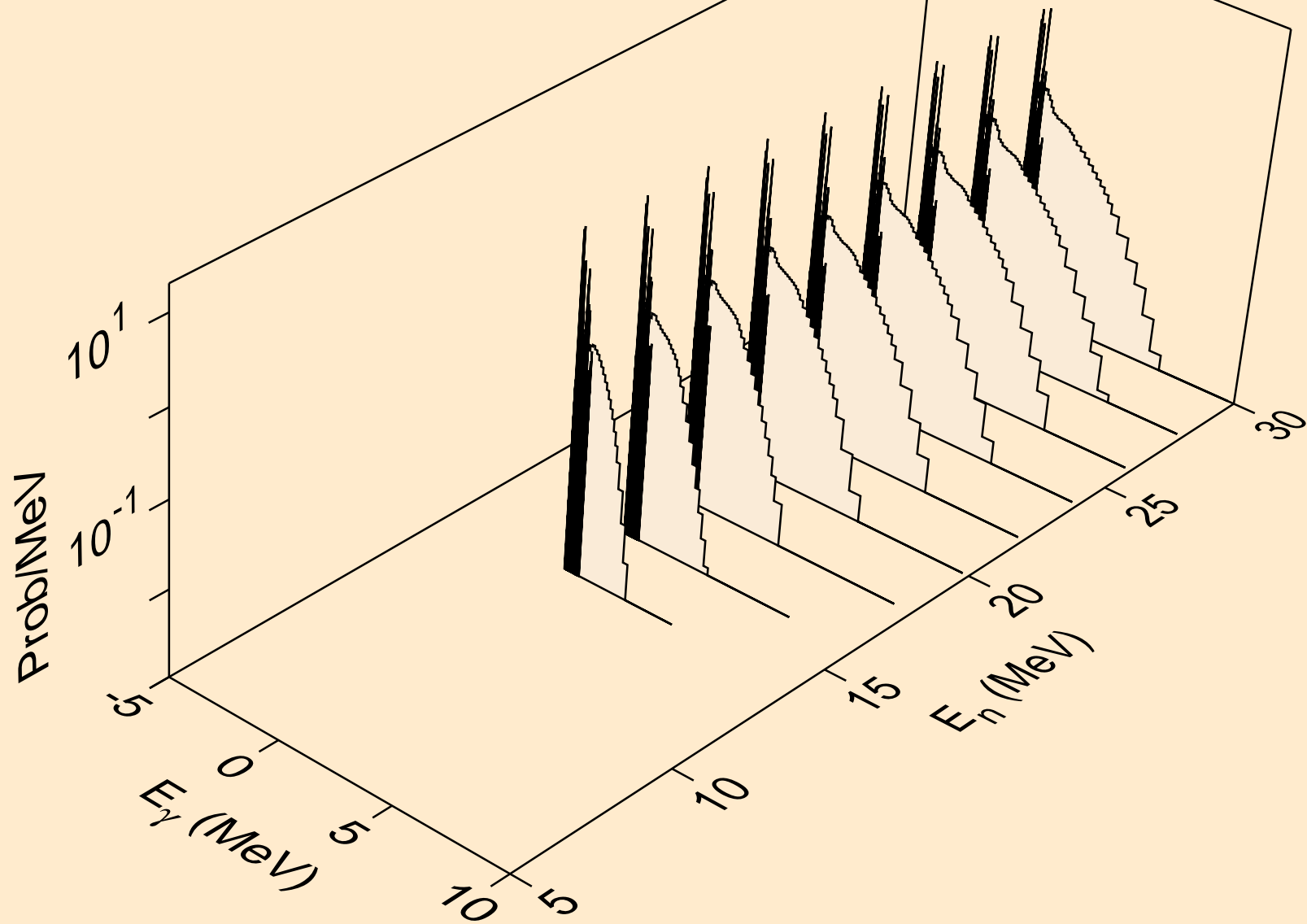

IR190 ALPHA ACER TENDL-2024 LIBRARY; T=0.K
Photon emission for (n,d)

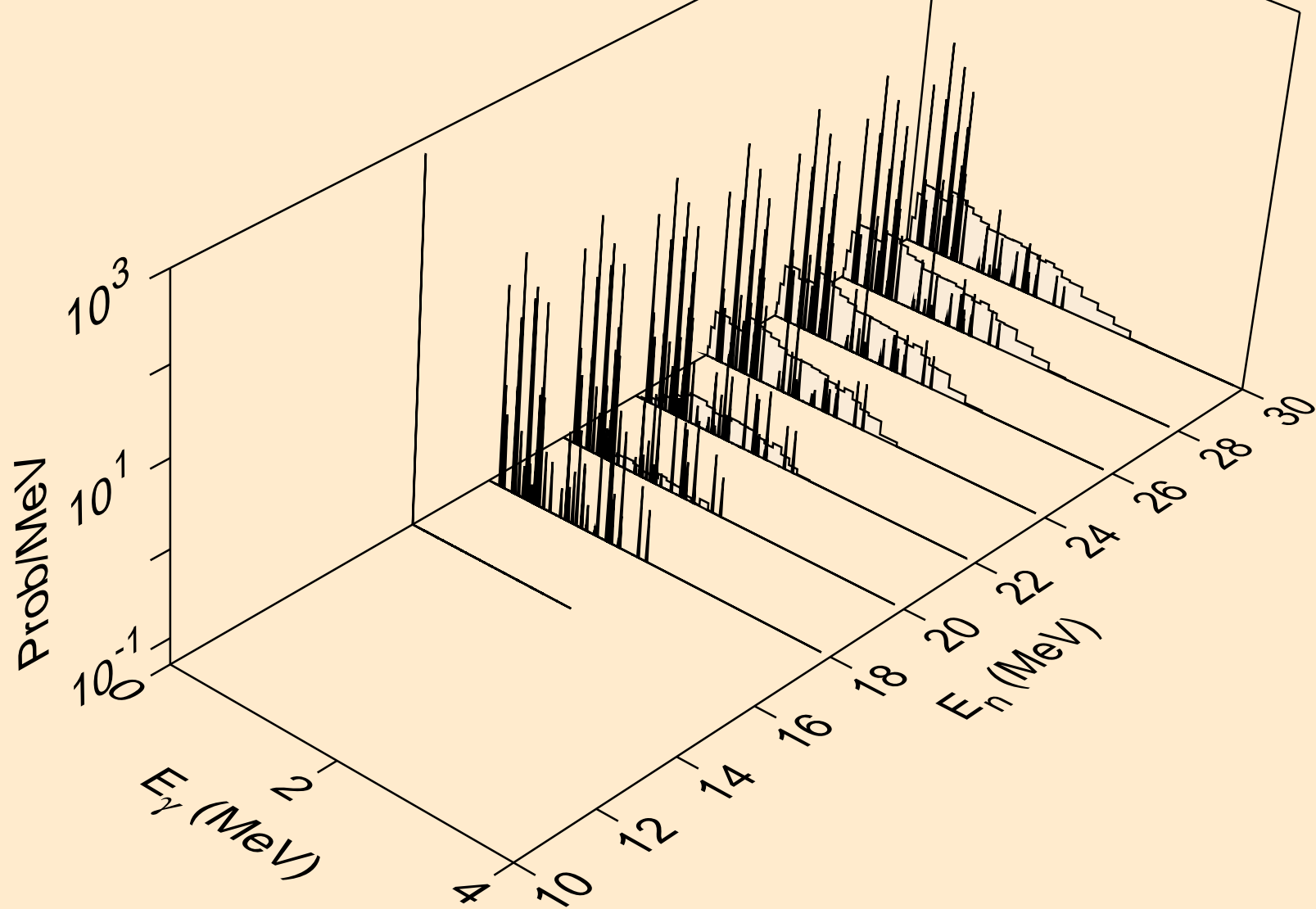

IR190 ALPHA ACER TENDL-2024 LIBRARY; T=0.K
Photon emission for (n,t)

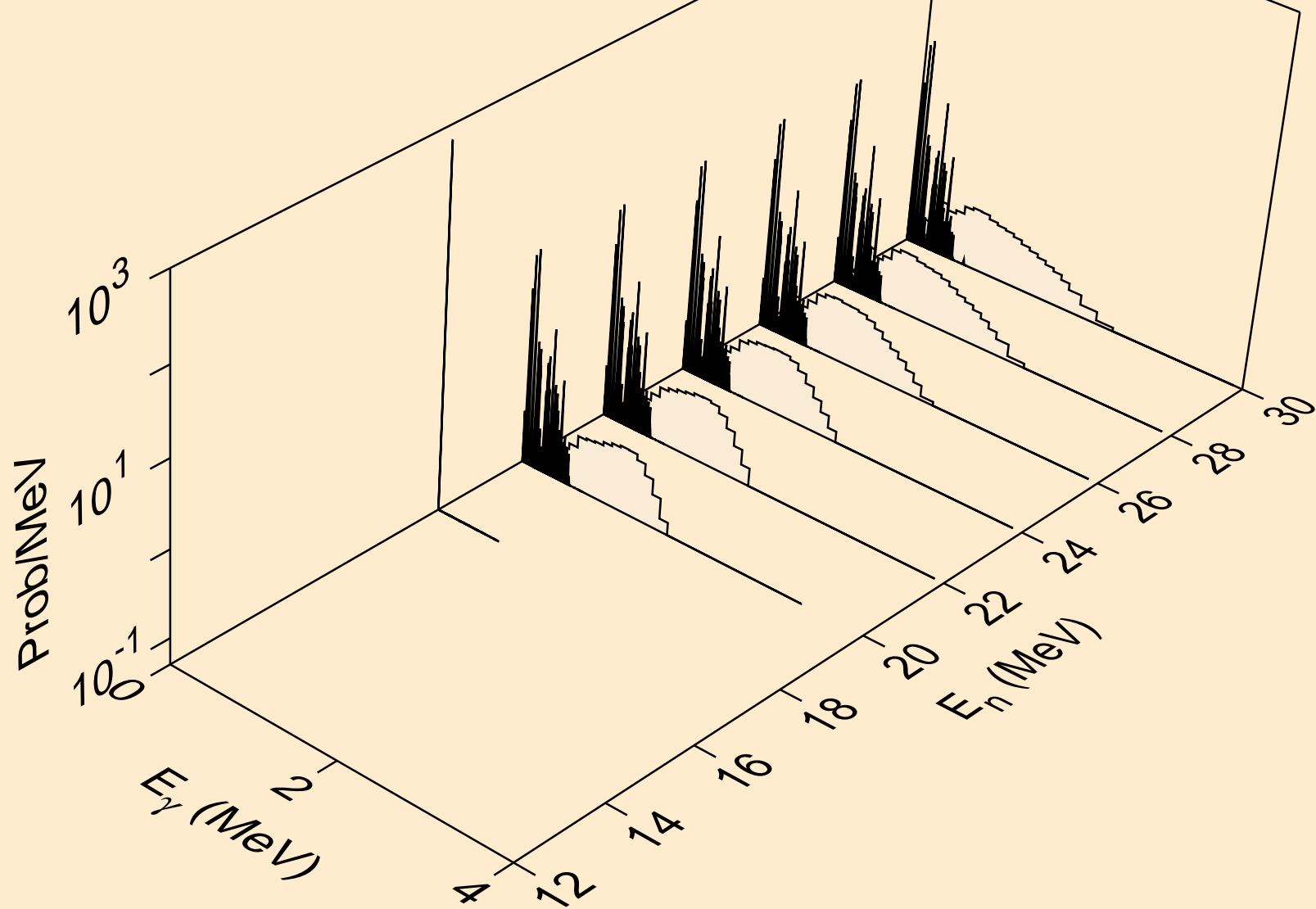

IR190 ALPHA ACER TENDL-2024 LIBRARY; T=0.K
Photon emission for (n,he3)

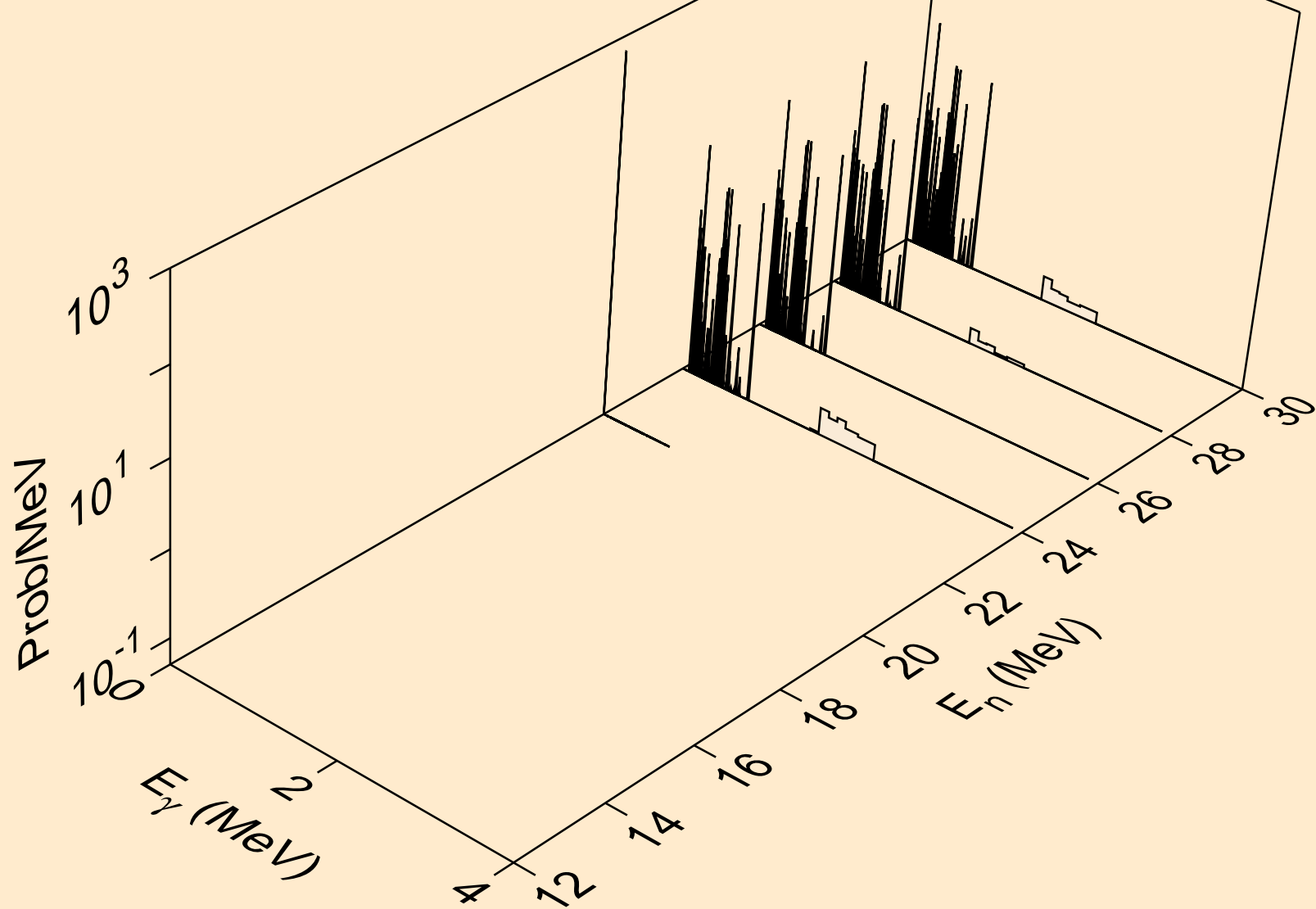

IR190 ALPHA ACER TENDL-2024 LIBRARY; T=0.K
Photon emission for inelastic

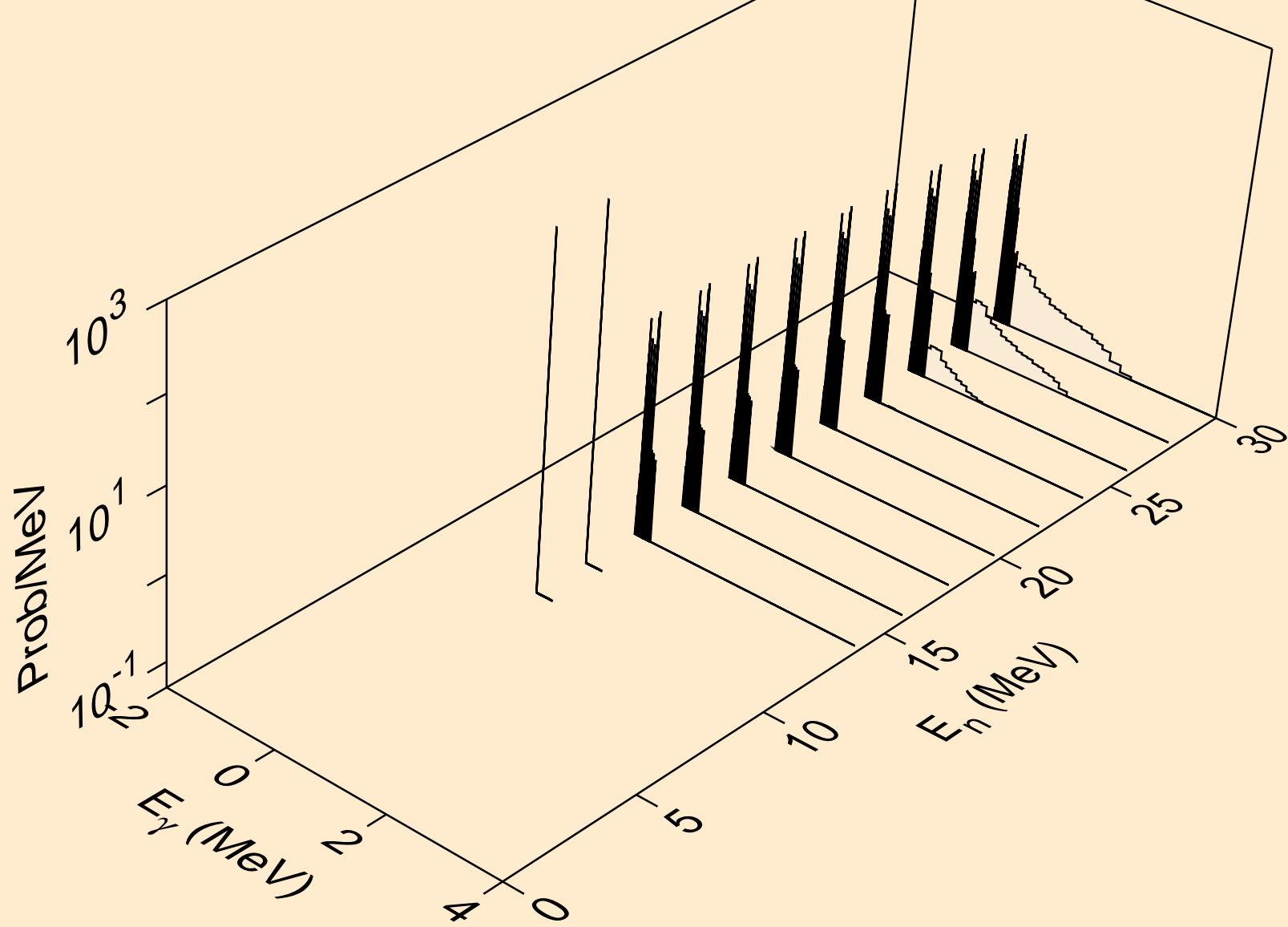

IR190 ALPHA ACER TENDL-2024 LIBRARY; T=0.K
Photon emission for (n,2p)

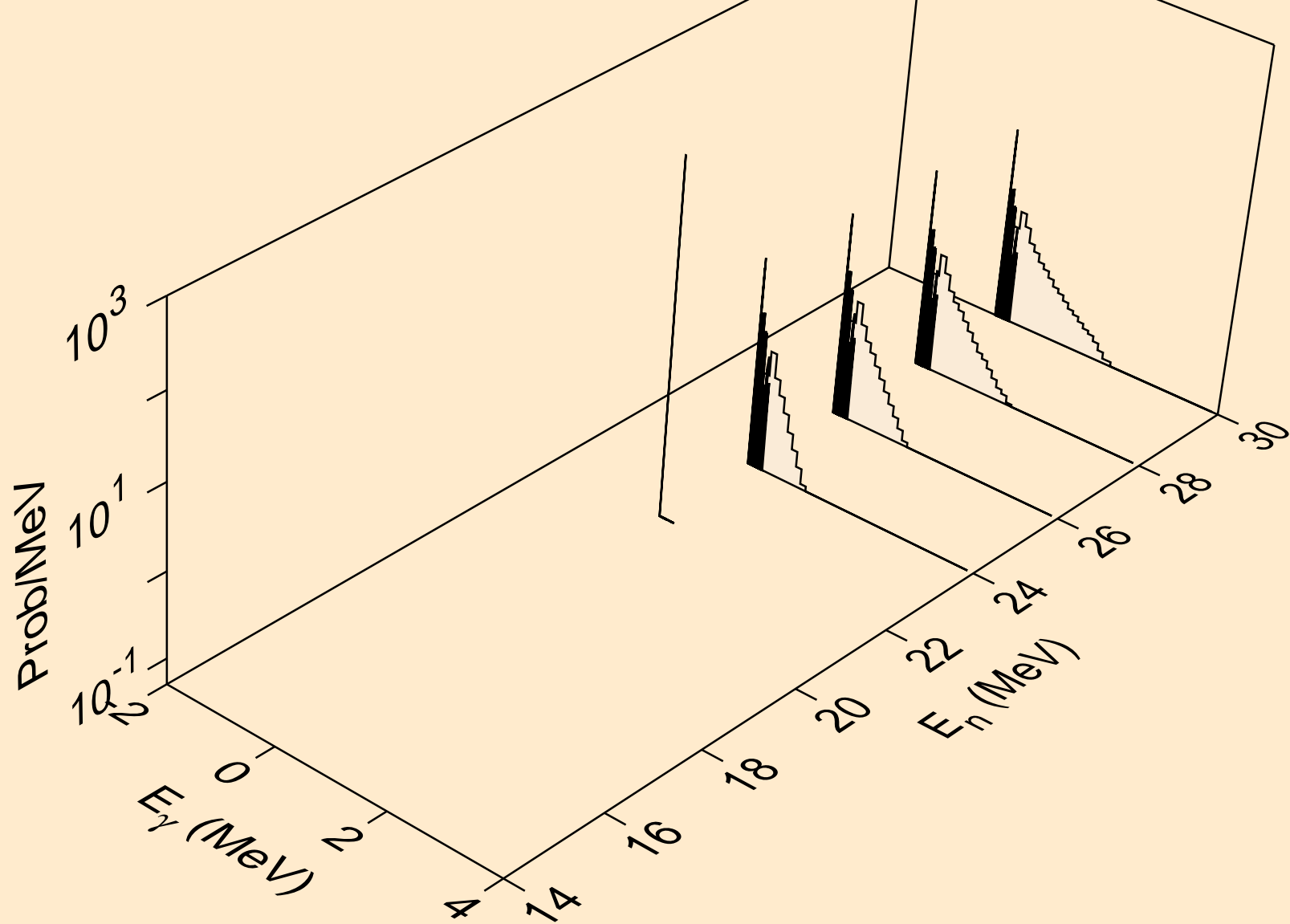

IR190 ALPHA ACER TENDL-2024 LIBRARY; T=0.K
Photon emission for (n,pa)

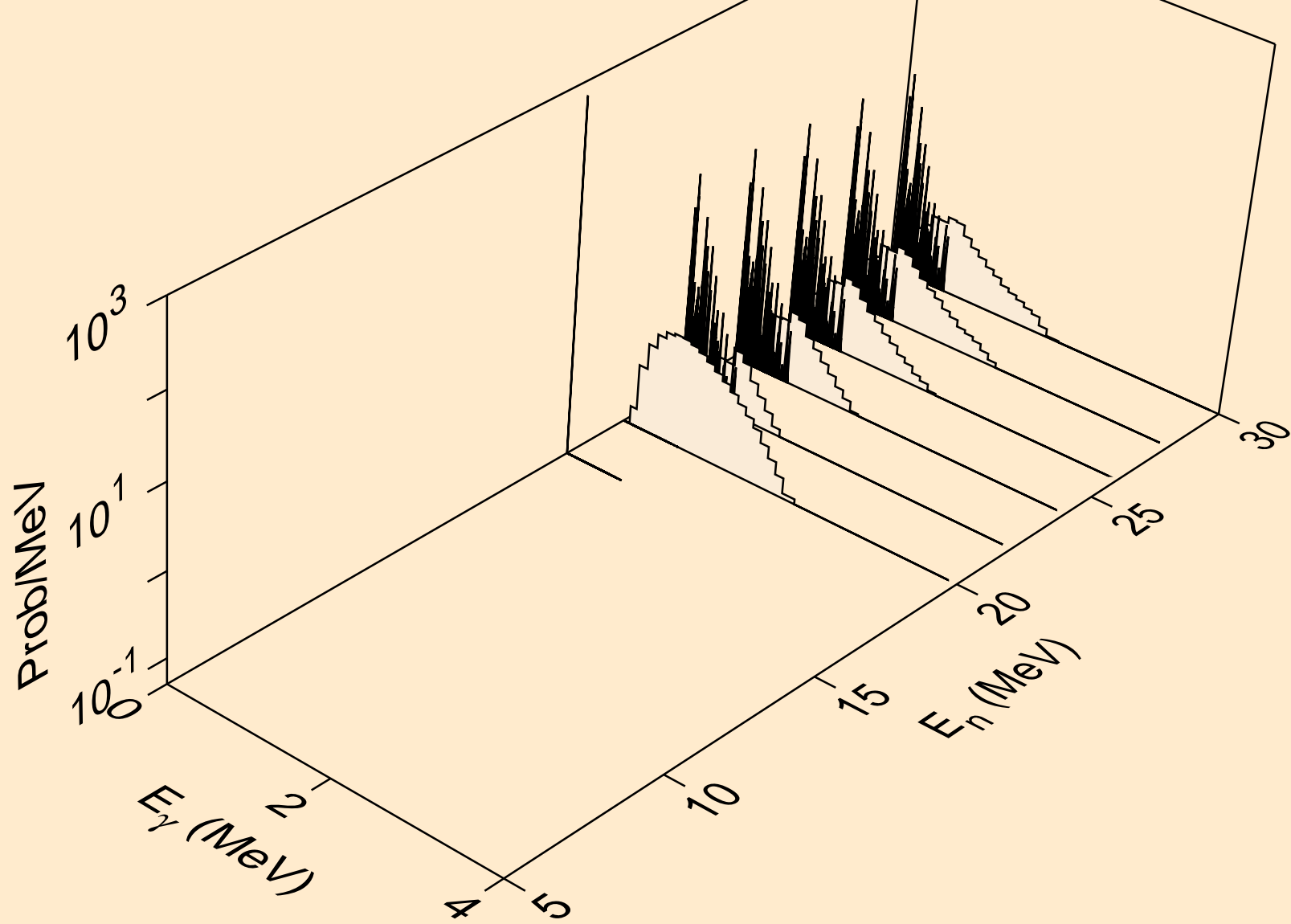

IR190 ALPHA ACER TENDL-2024 LIBRARY; T=0.K
Particle heating contributions

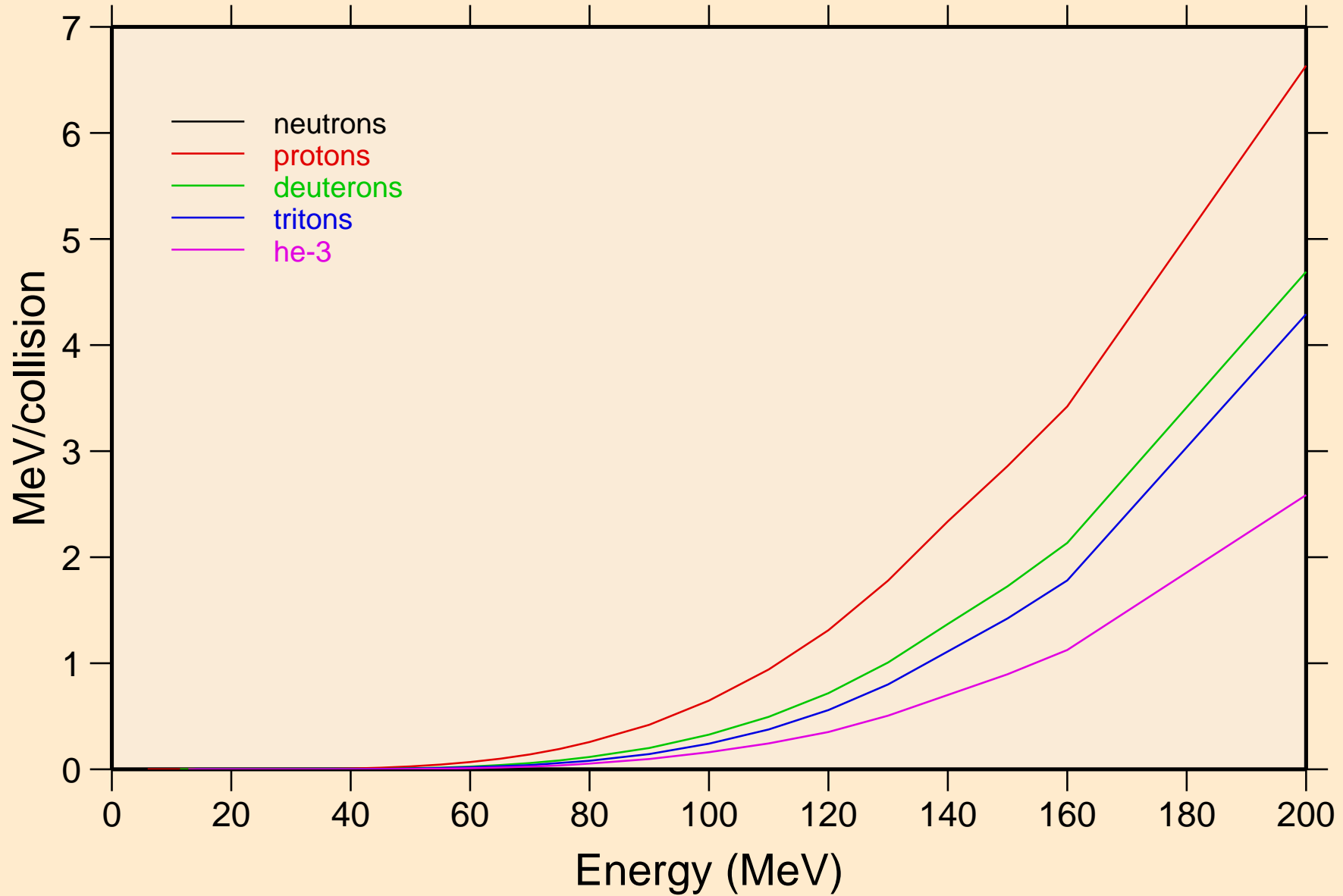

IR190 ALPHA ACER TENDL-2024 LIBRARY; T=0.K
Recoil Heating

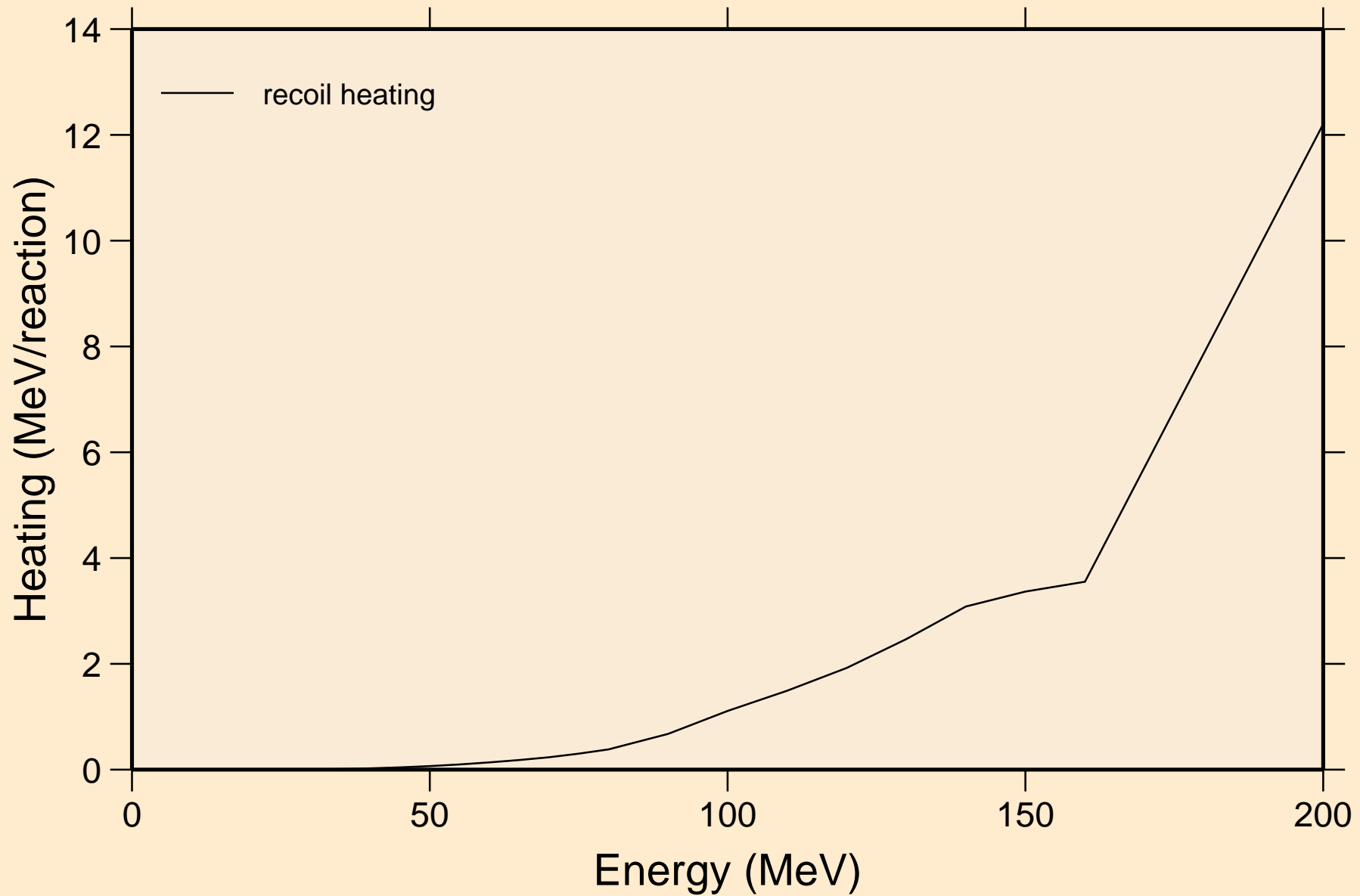

IR190 ALPHA ACER TENDL-2024 LIBRARY; T=0.K
Particle production cross sections

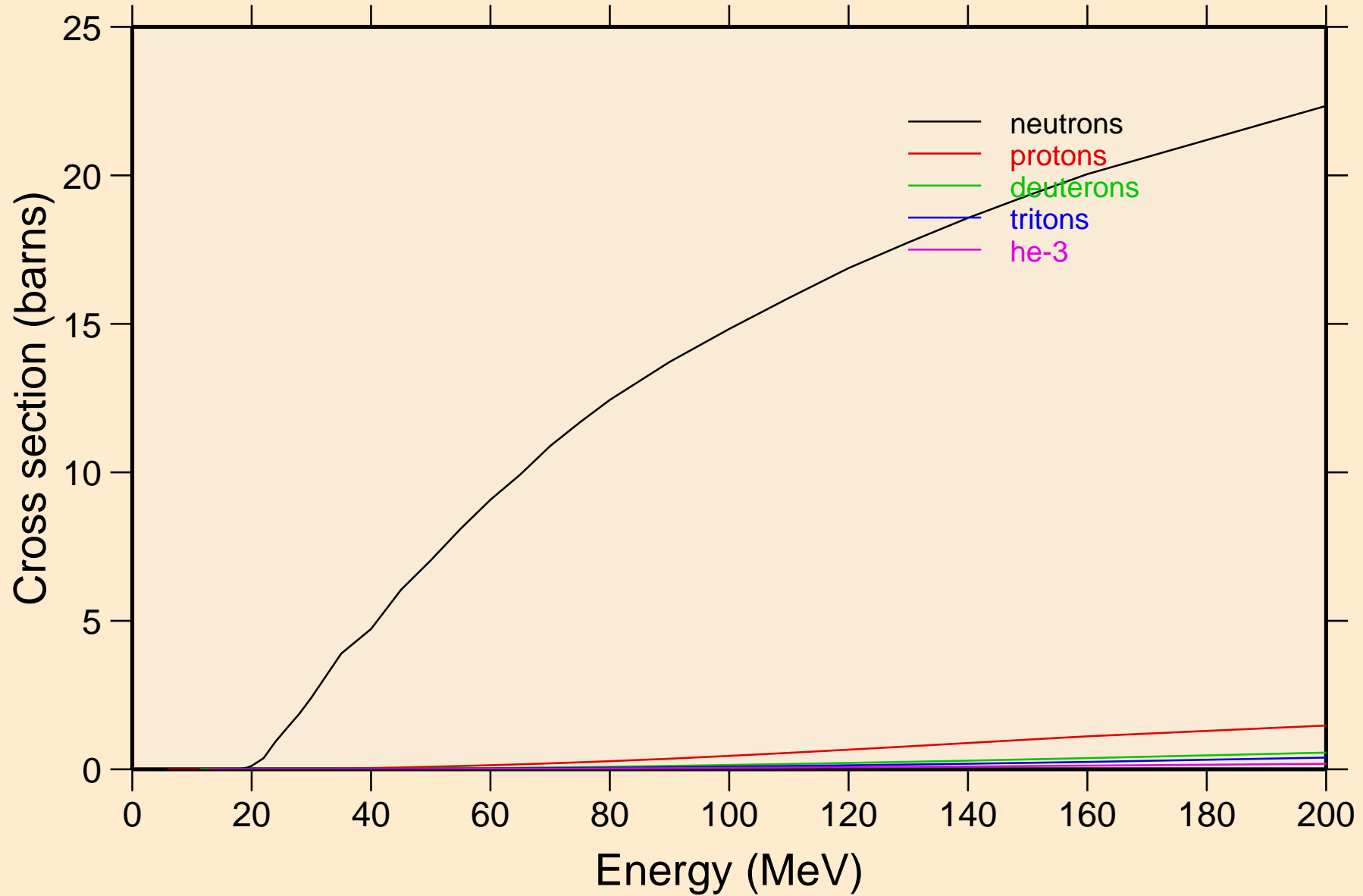

IR190 ALPHA ACER TENDL-2024 LIBRARY; T=0.K
neutrons from (a,n)

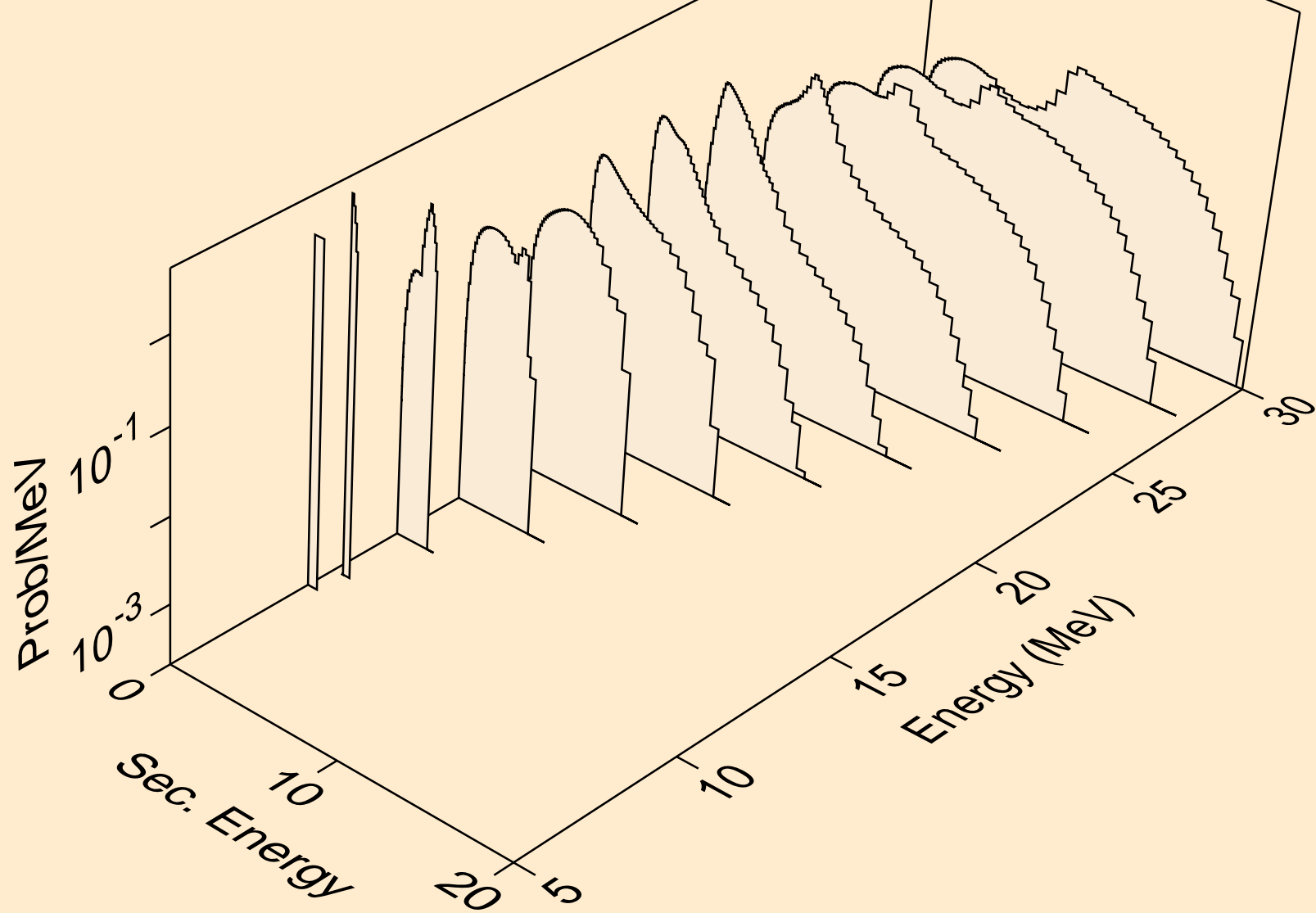

IR190 ALPHA ACER TENDL-2024 LIBRARY; T=0.K
neutrons from (a,x)

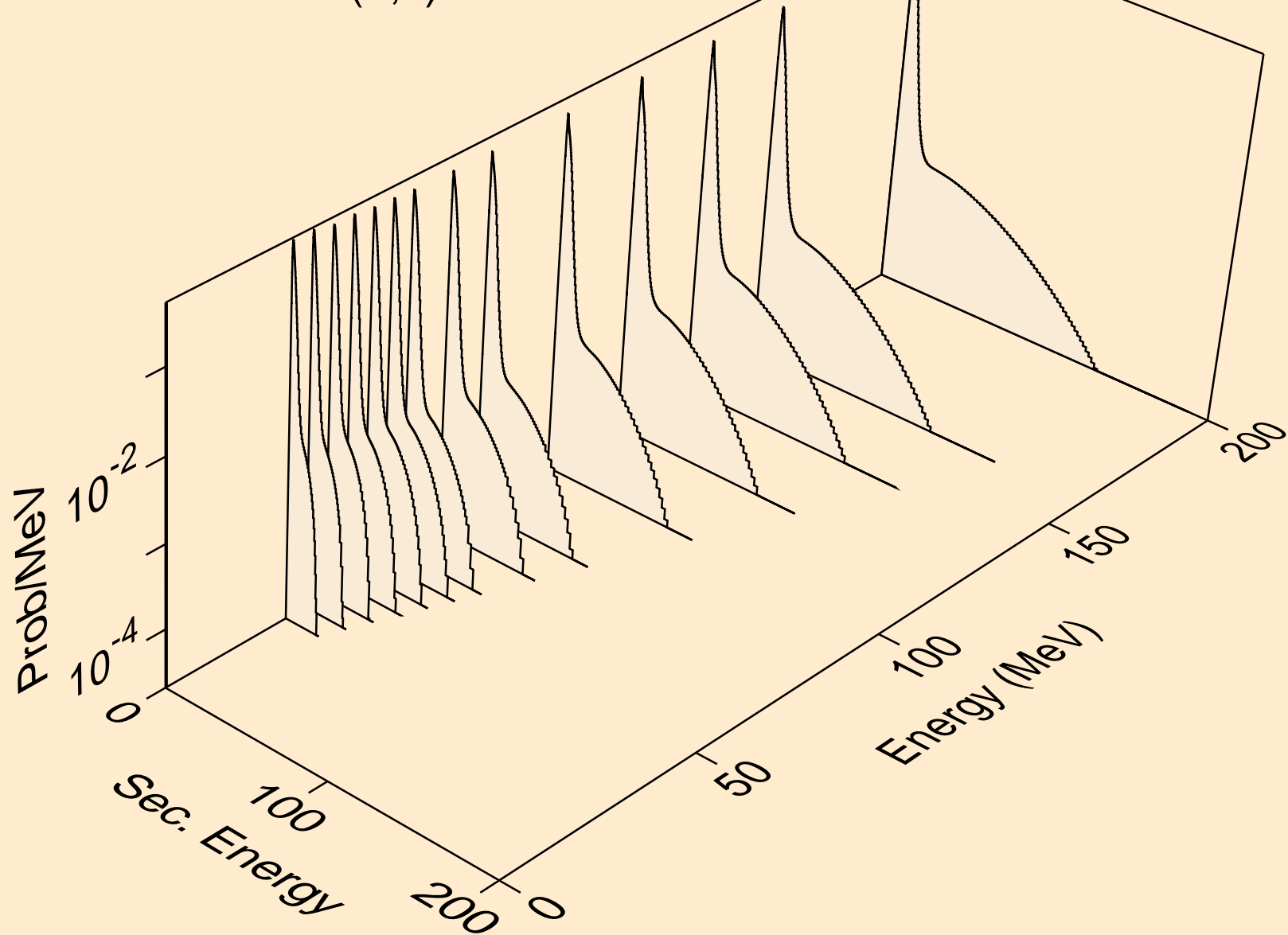

IR190 ALPHA ACER TENDL-2024 LIBRARY; T=0.K
neutrons from (a,2n)

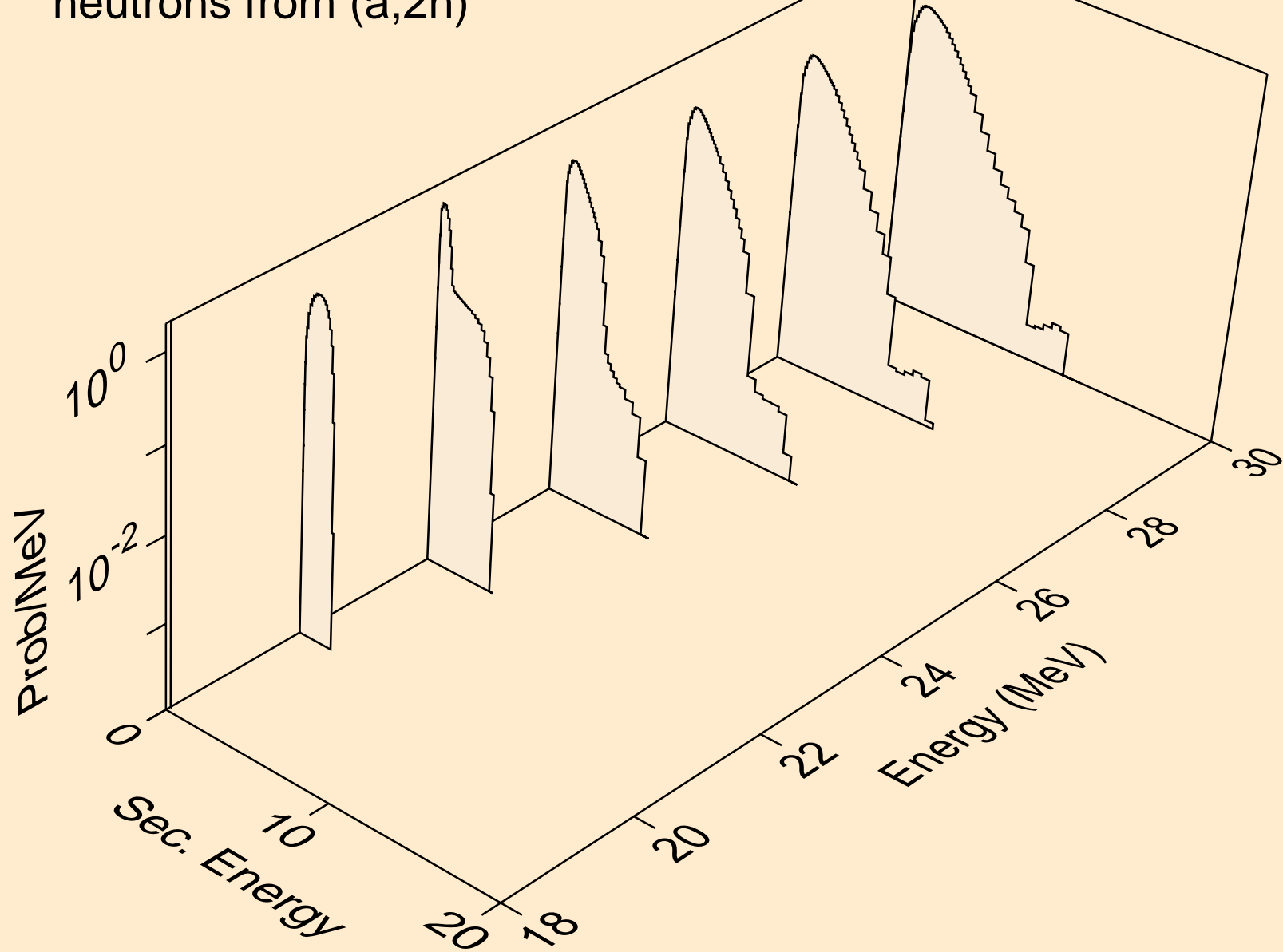

IR190 ALPHA ACER TENDL-2024 LIBRARY; T=0.K
neutrons from (a,3n)

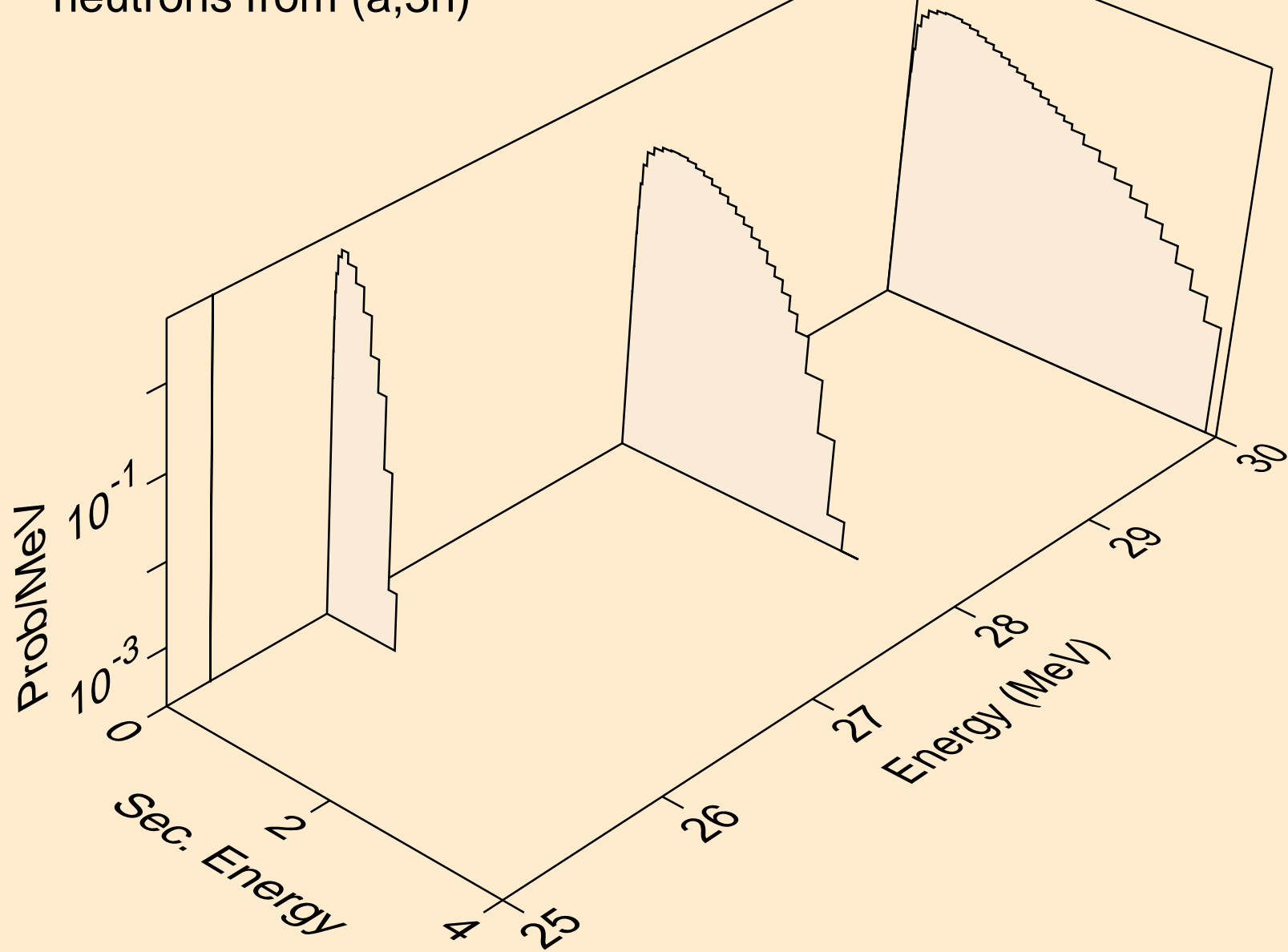

IR190 ALPHA ACER TENDL-2024 LIBRARY; T=0.K
neutrons from (a,n*)a

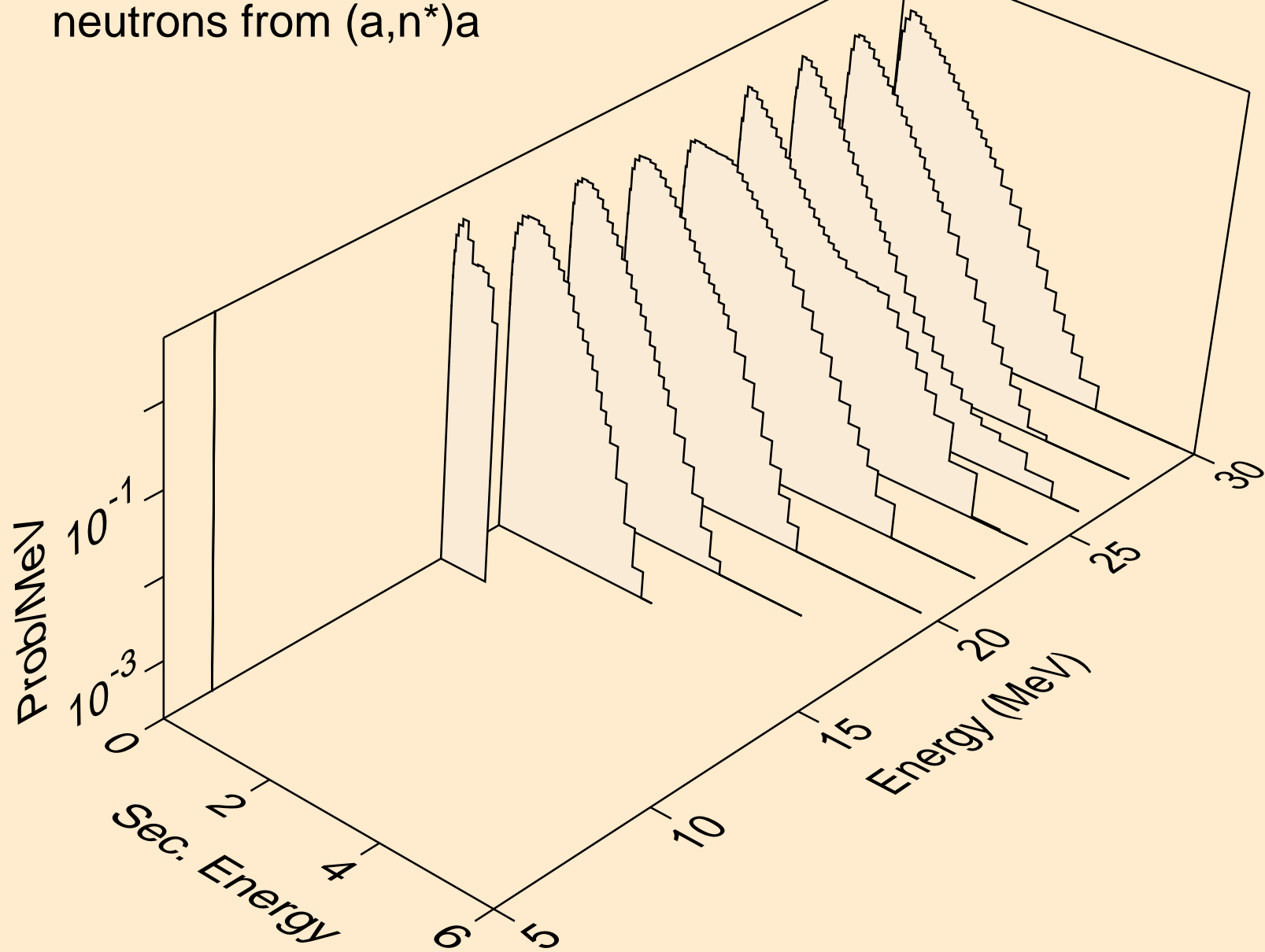

IR190 ALPHA ACER TENDL-2024 LIBRARY; T=0.K
neutrons from (a,2n)a

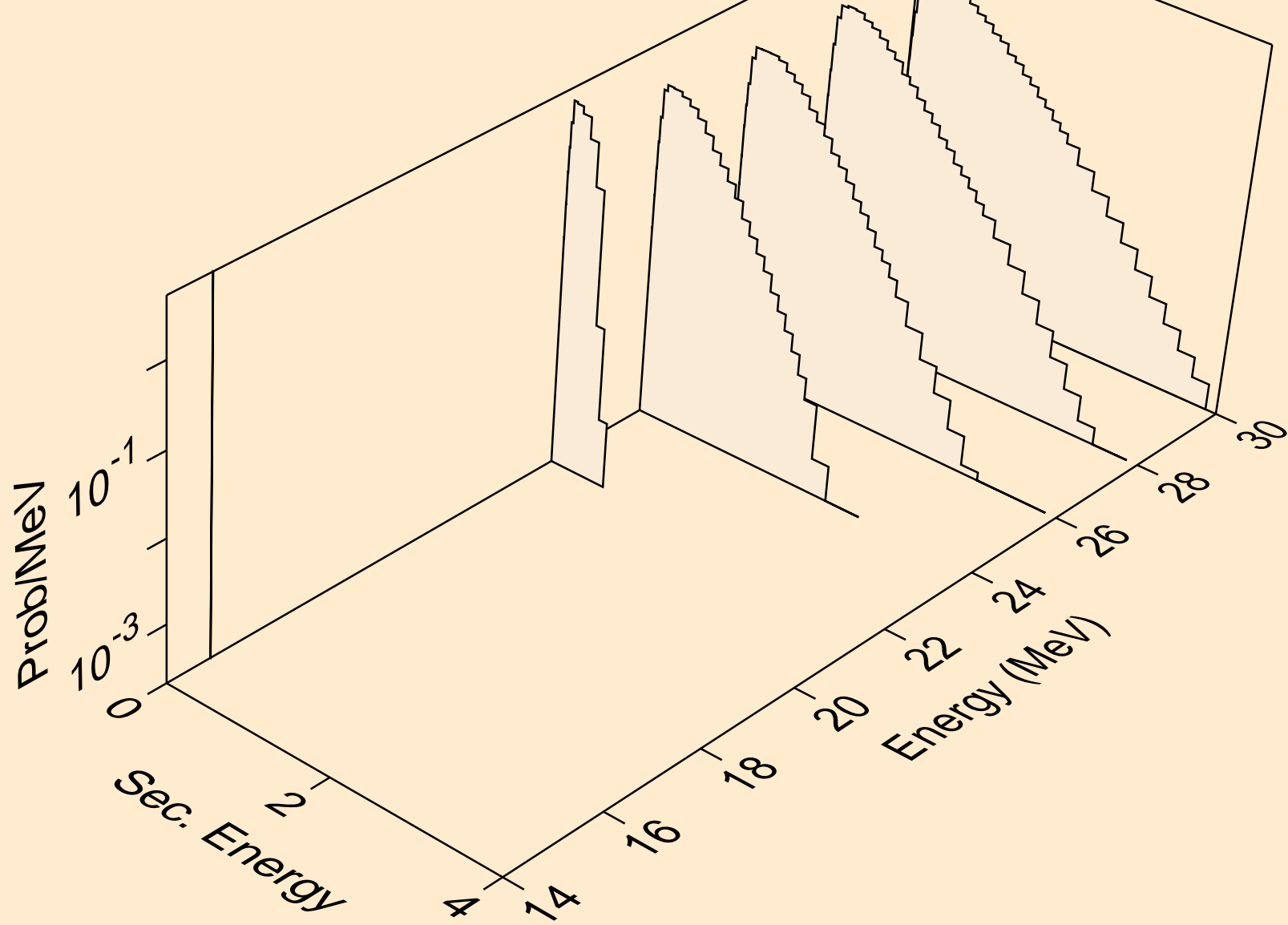

IR190 ALPHA ACER TENDL-2024 LIBRARY; T=0.K
neutrons from (a,n*)p

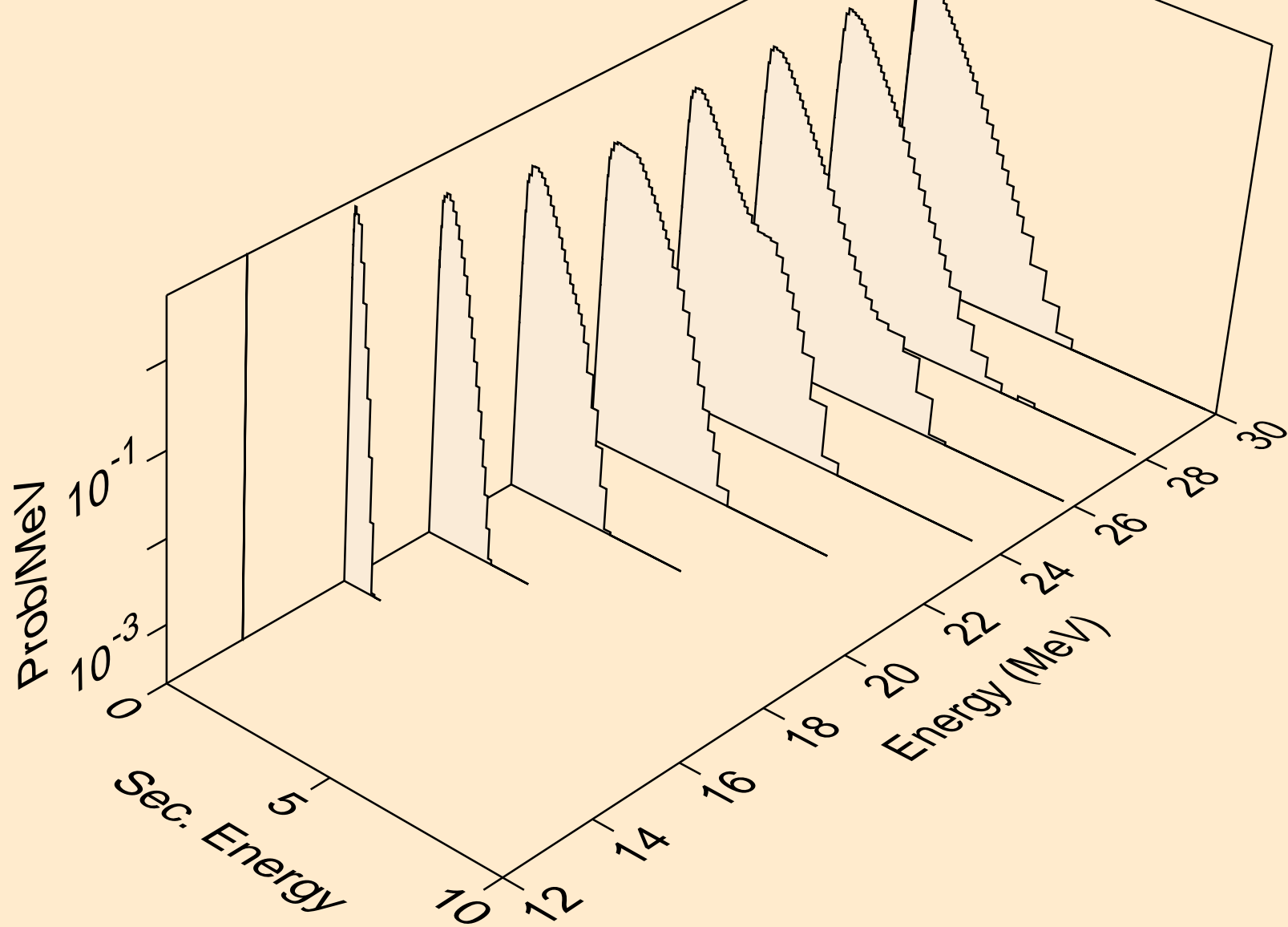

IR190 ALPHA ACER TENDL-2024 LIBRARY; T=0.K
neutrons from (a,n*)d

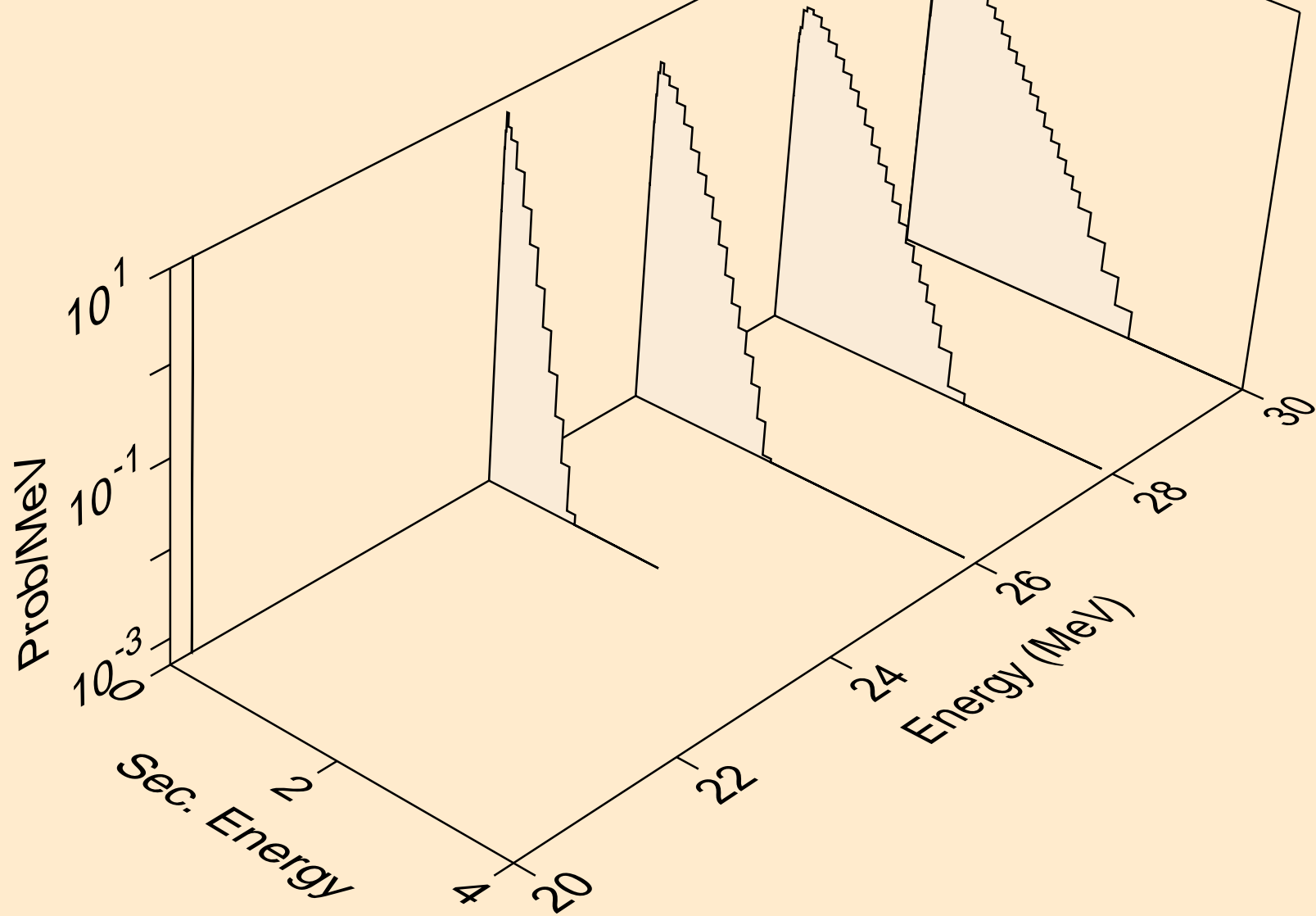

IR190 ALPHA ACER TENDL-2024 LIBRARY; T=0.K
neutrons from (a,n*)t

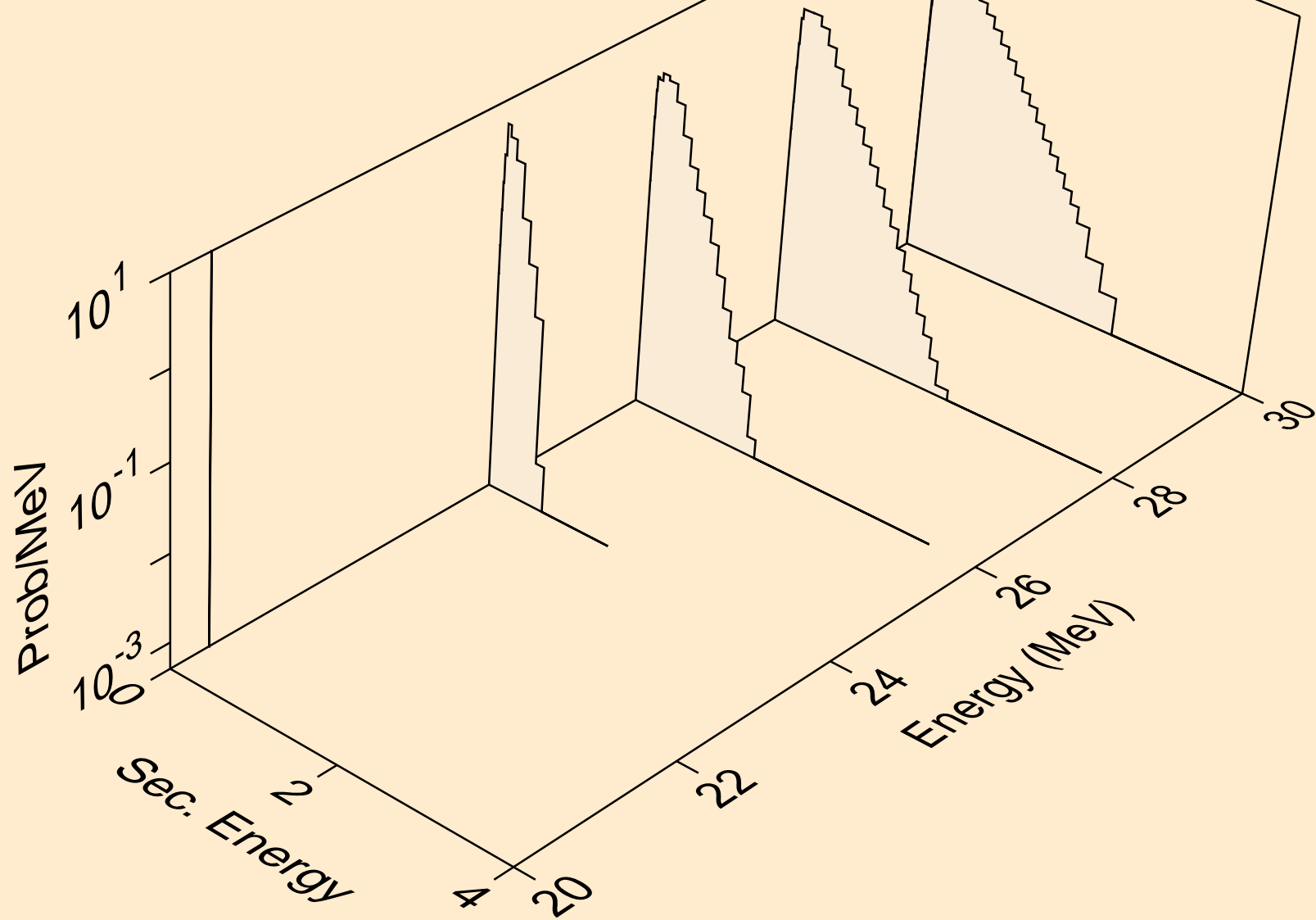

IR190 ALPHA ACER TENDL-2024 LIBRARY; T=0.K
neutrons from (a,2np)

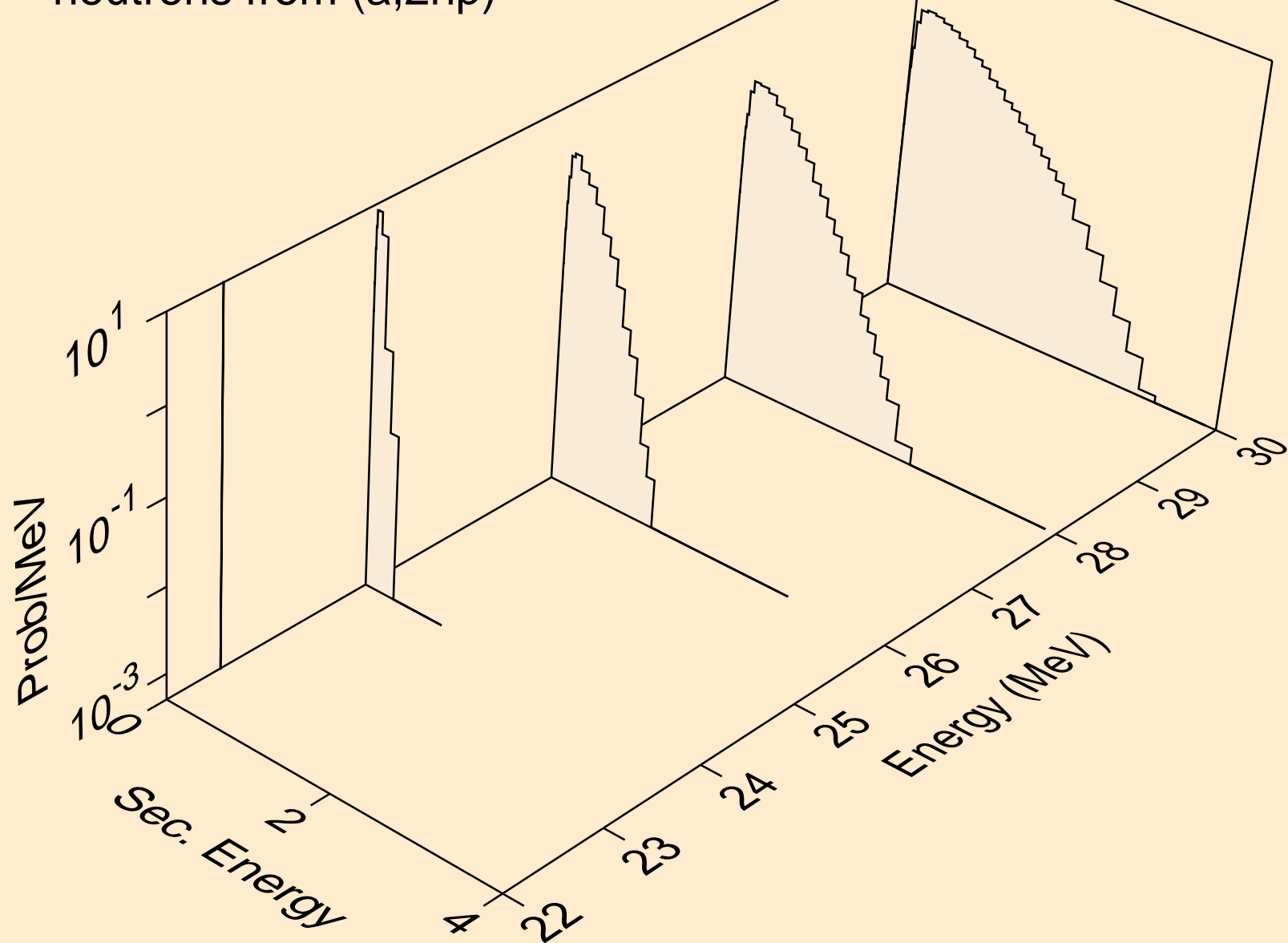

IR190 ALPHA ACER TENDL-2024 LIBRARY; T=0.K
protons from (a,x)

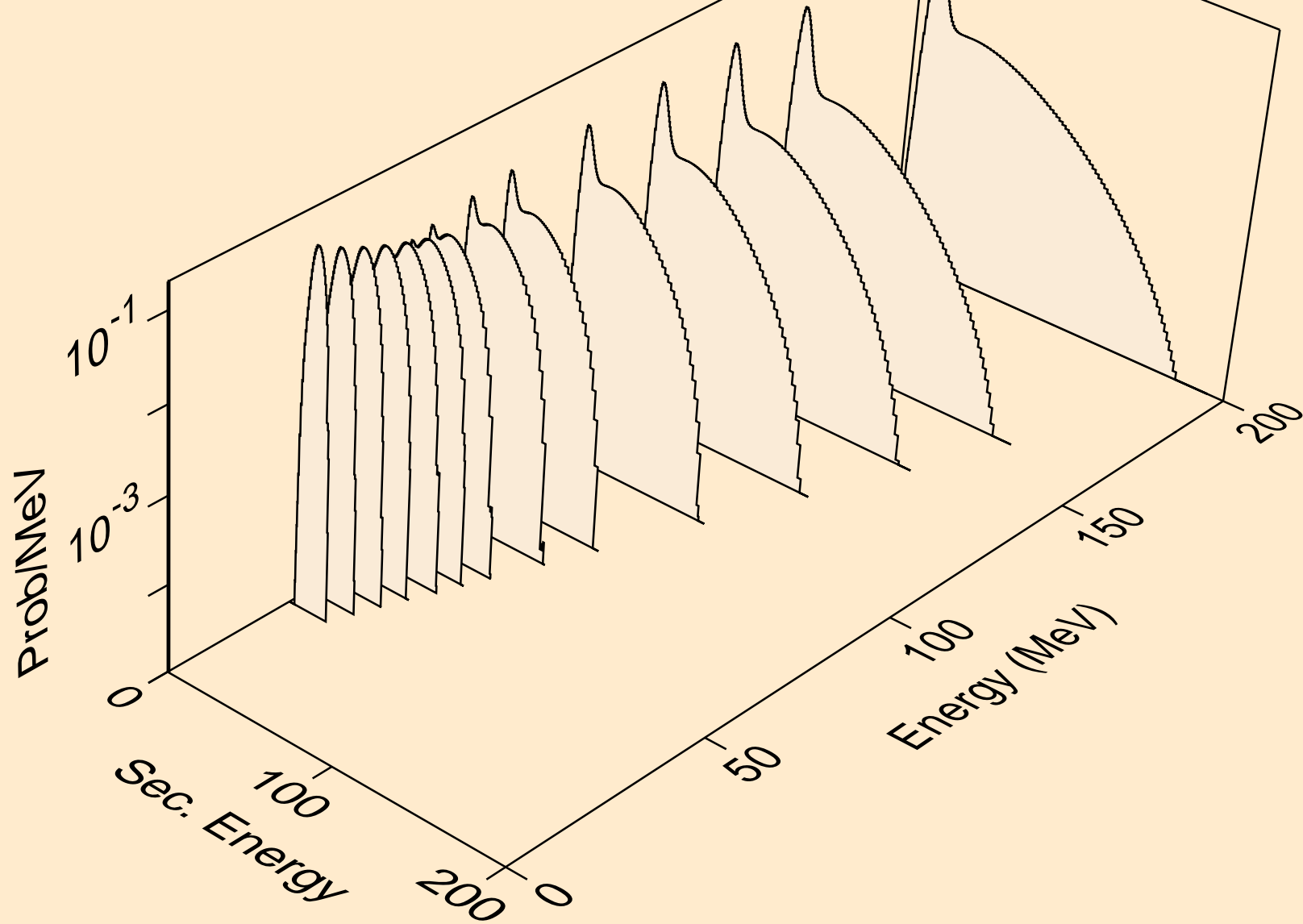

IR190 ALPHA ACER TENDL-2024 LIBRARY; T=0.K
protons from (a,n*)p

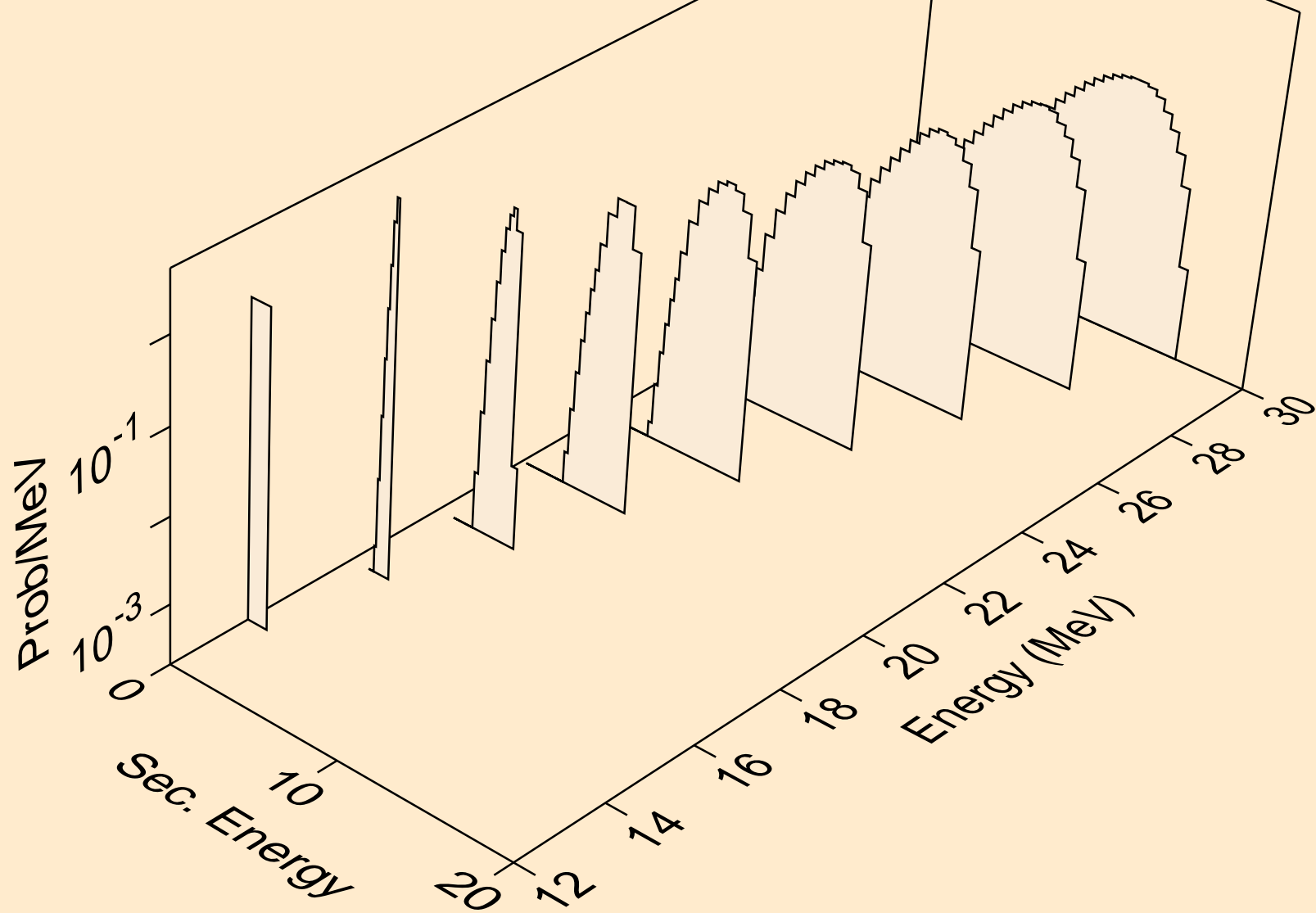

IR190 ALPHA ACER TENDL-2024 LIBRARY; T=0.K
protons from (a,2np)

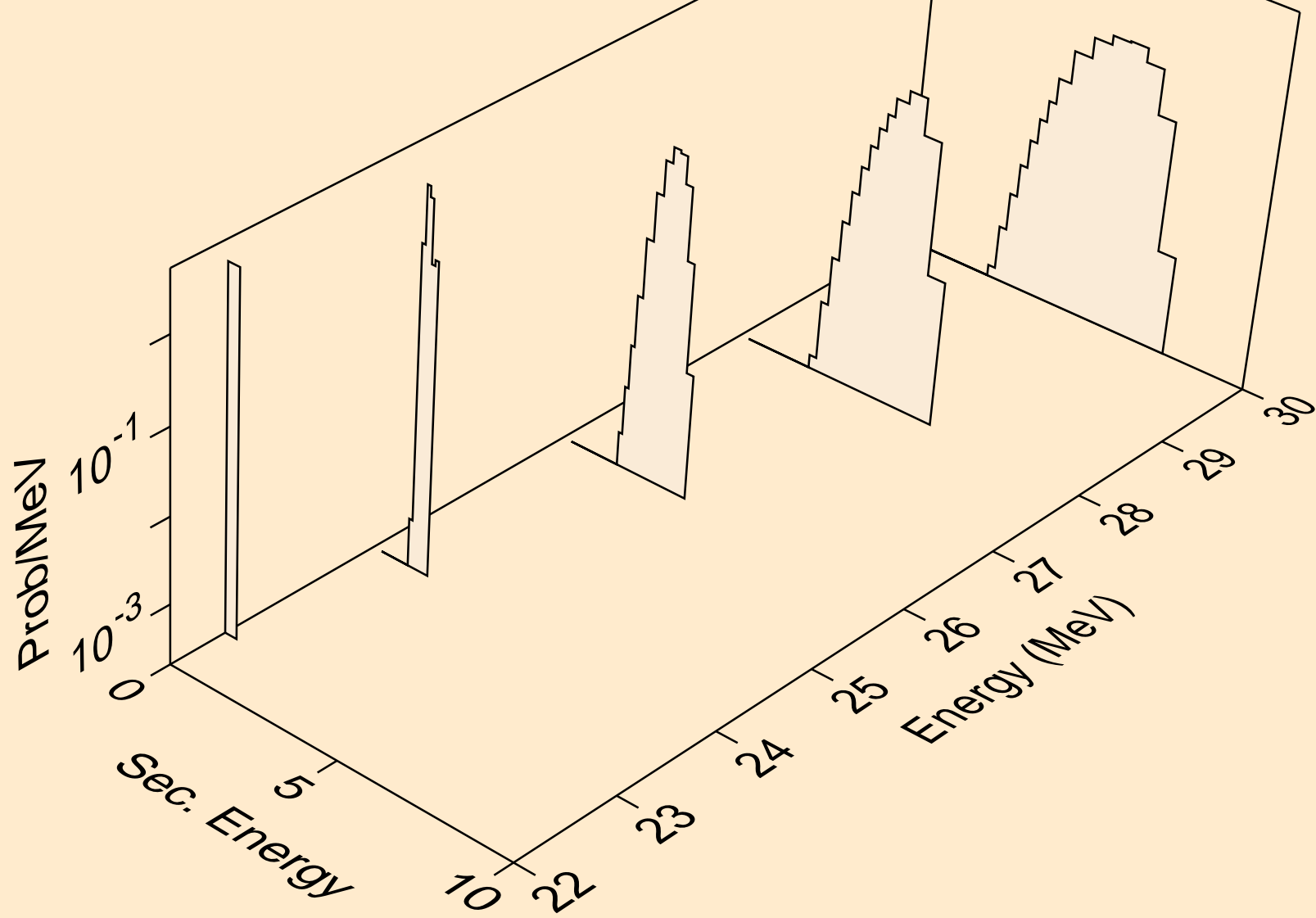

IR190 ALPHA ACER TENDL-2024 LIBRARY; T=0.K
protons from (a,p)

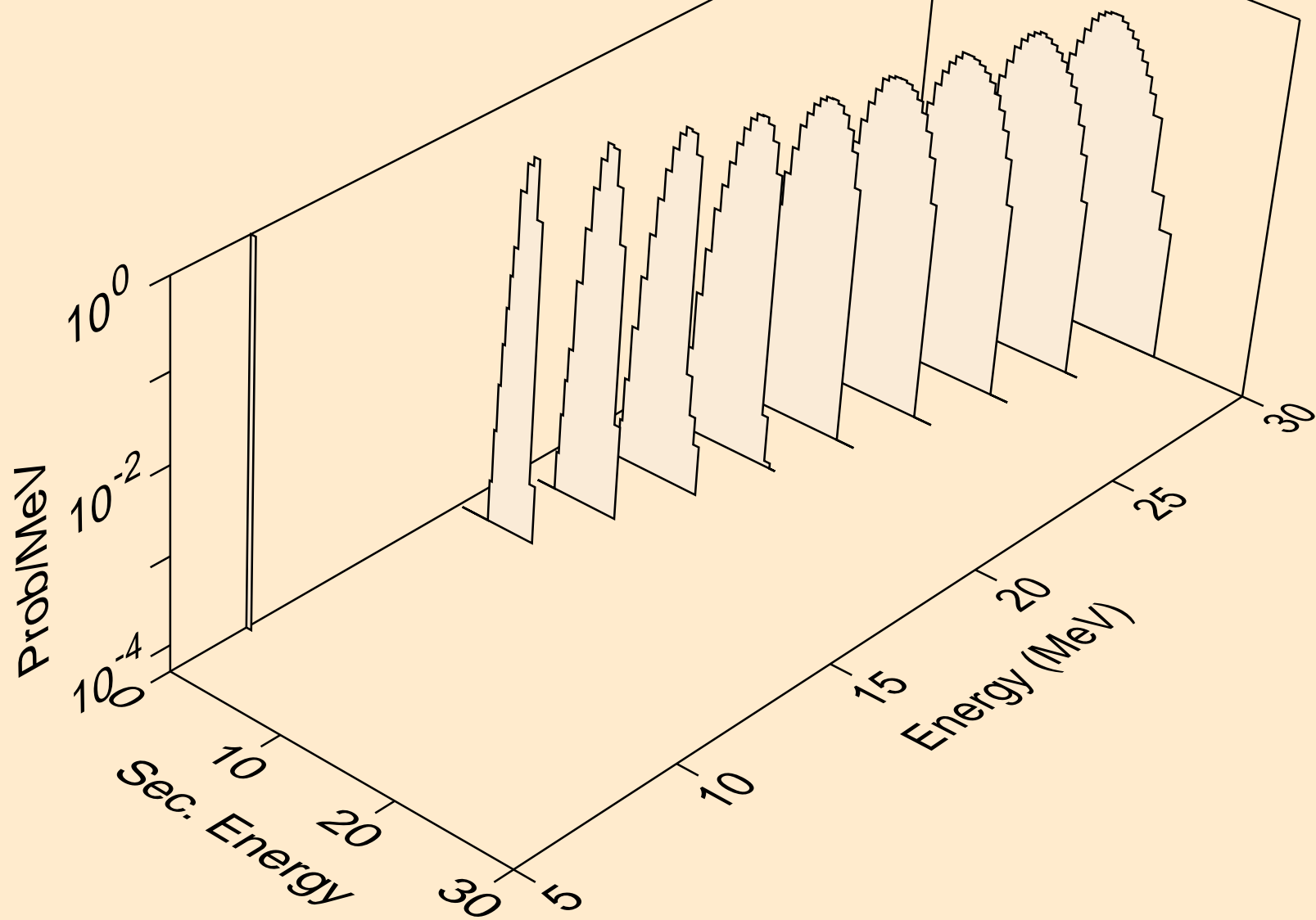

IR190 ALPHA ACER TENDL-2024 LIBRARY; T=0.K
protons from (a,2p)

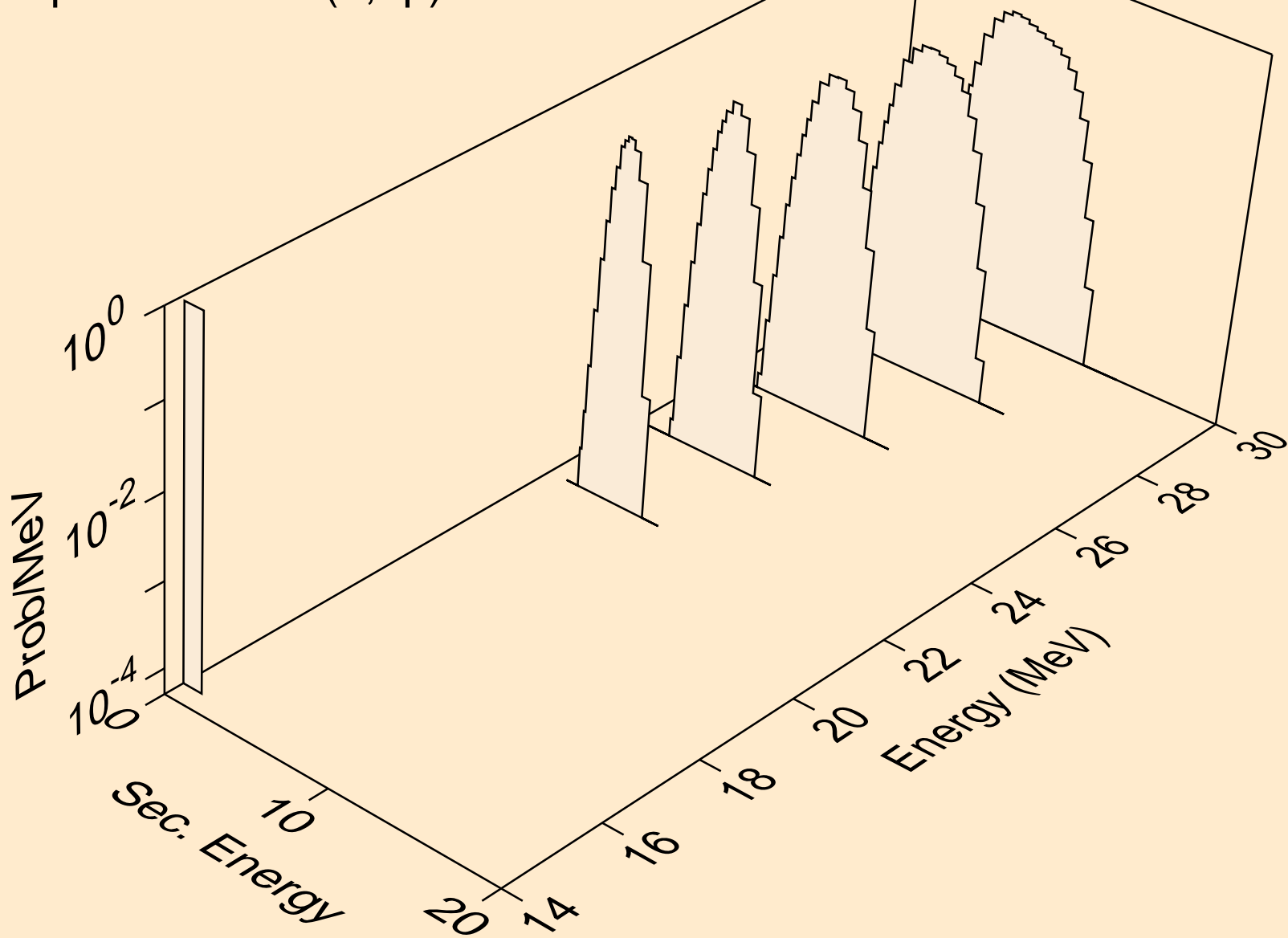

IR190 ALPHA ACER TENDL-2024 LIBRARY; T=0.K
protons from (a,pa)

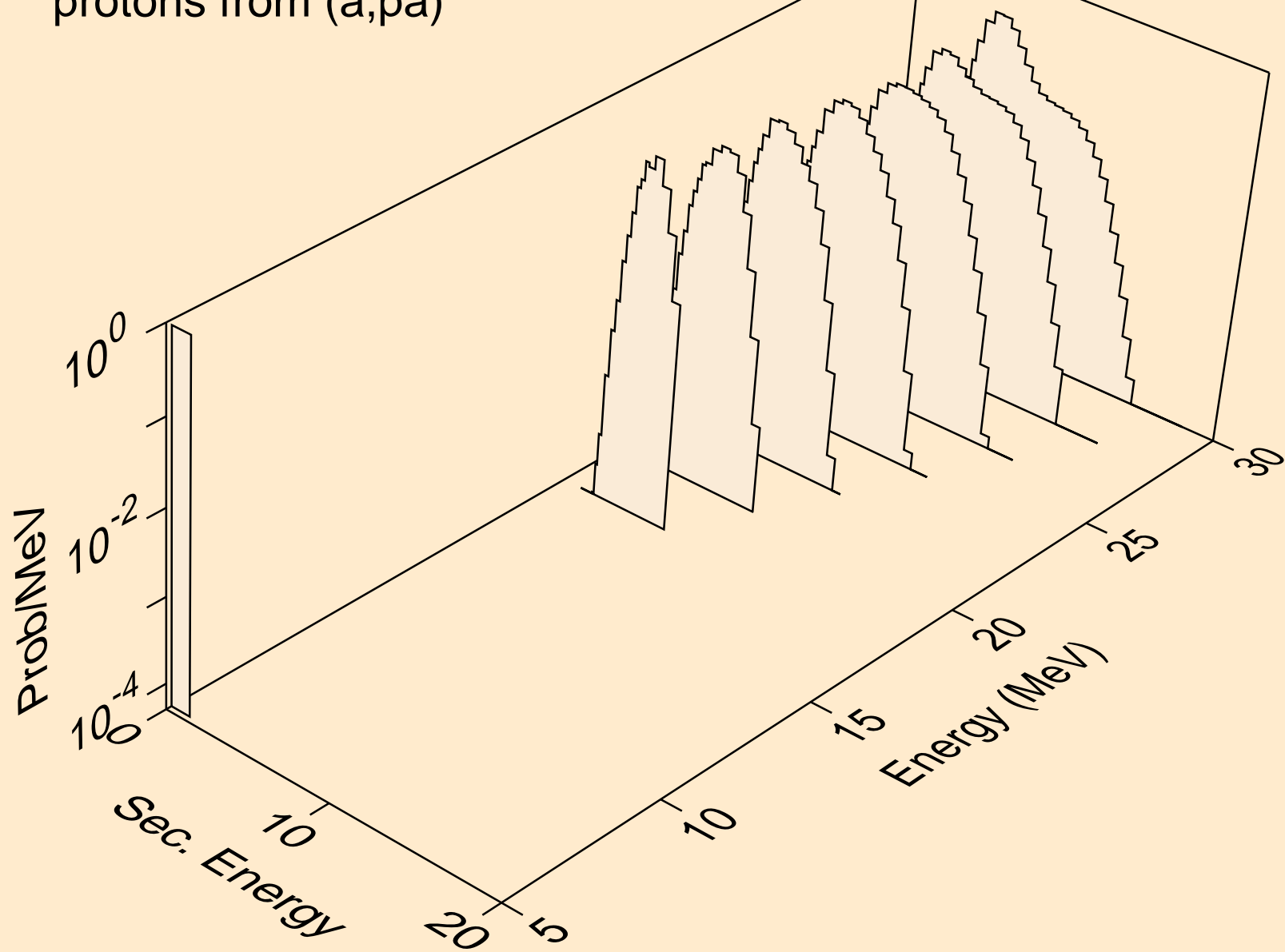

IR190 ALPHA ACER TENDL-2024 LIBRARY; T=0.K
deuterons from (a,x)

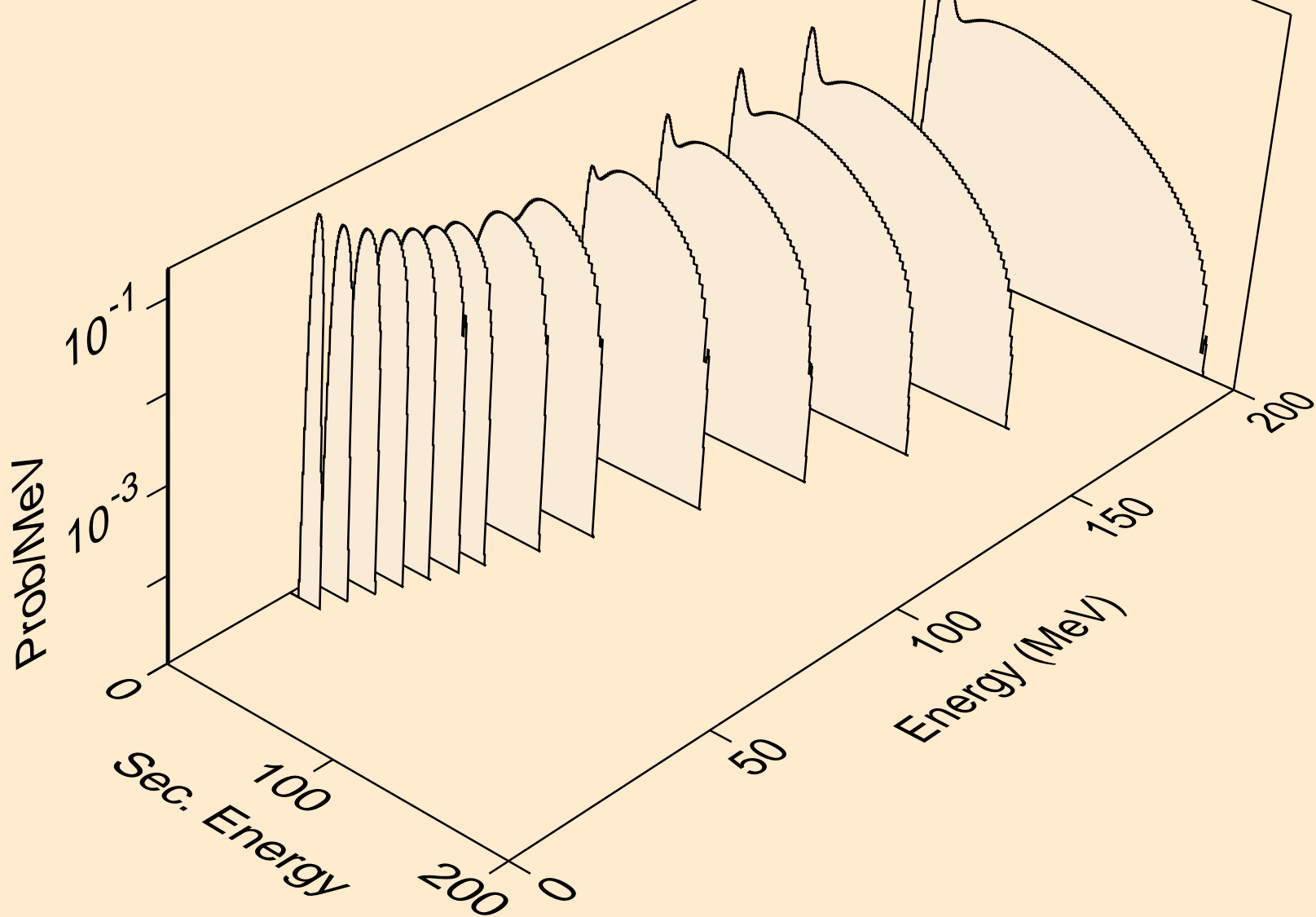

IR190 ALPHA ACER TENDL-2024 LIBRARY; T=0.K
deuterons from (a,n*)d

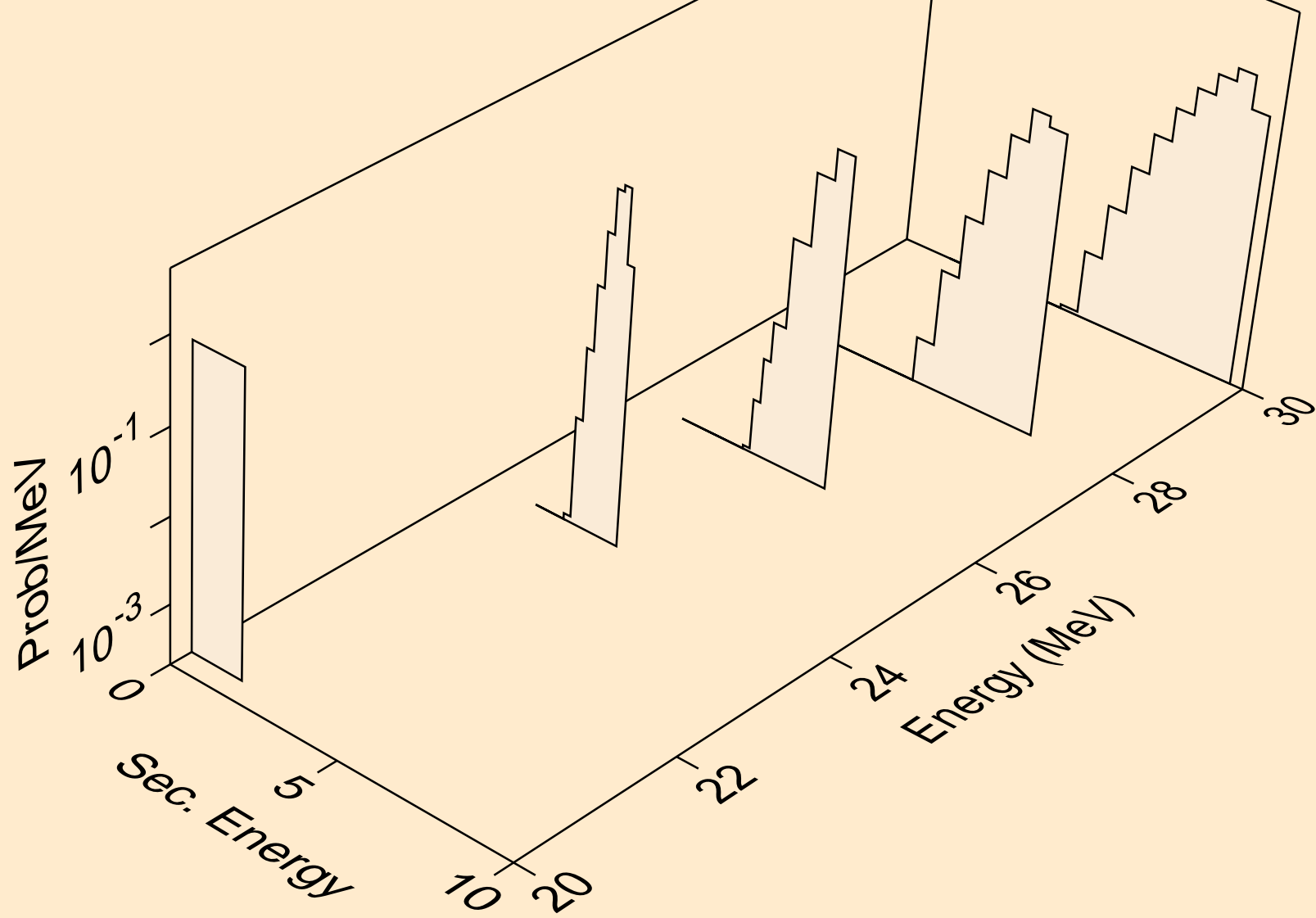

IR190 ALPHA ACER TENDL-2024 LIBRARY; T=0.K
deuterons from (a,d)

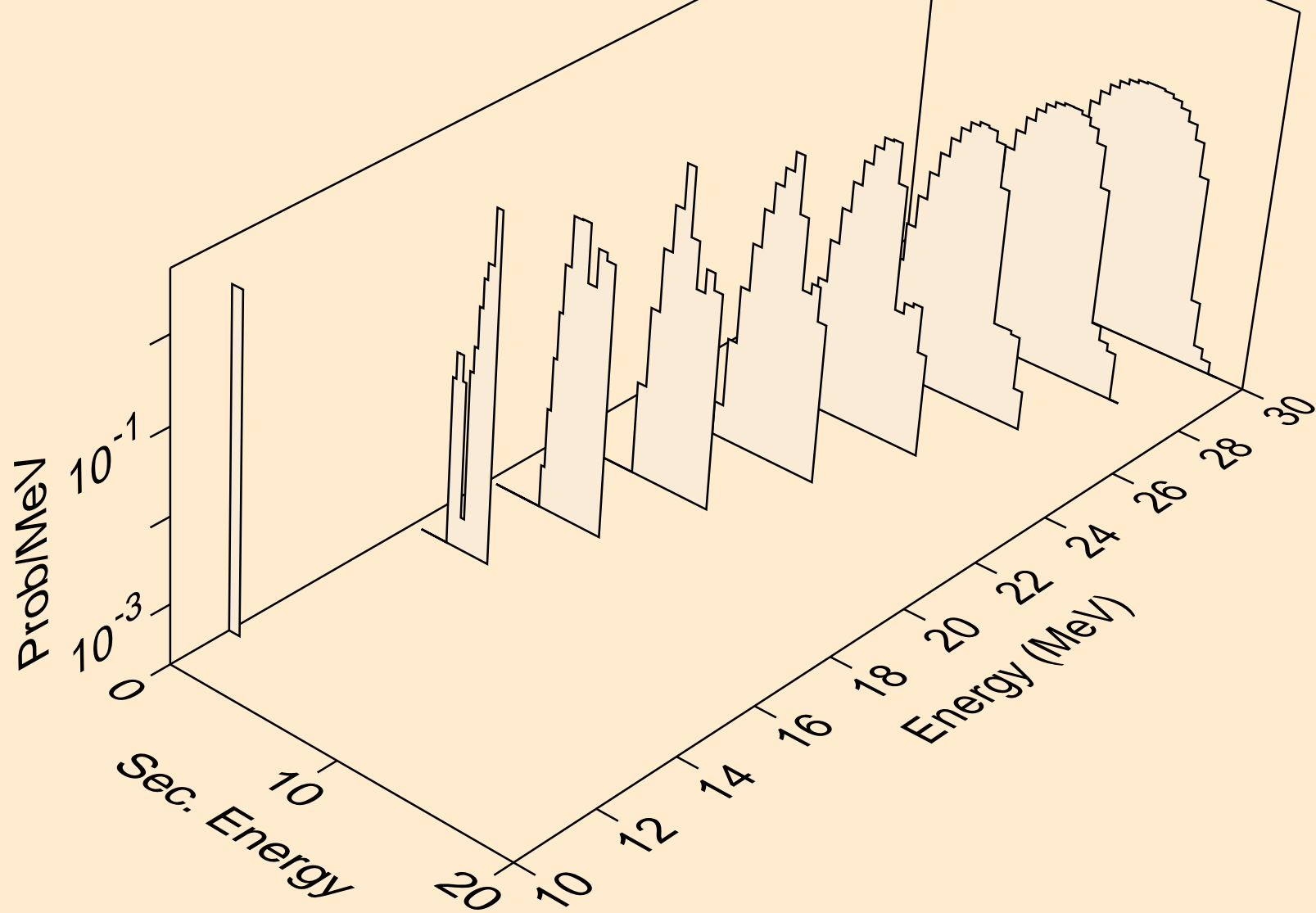

IR190 ALPHA ACER TENDL-2024 LIBRARY; T=0.K
tritons from (a,x)

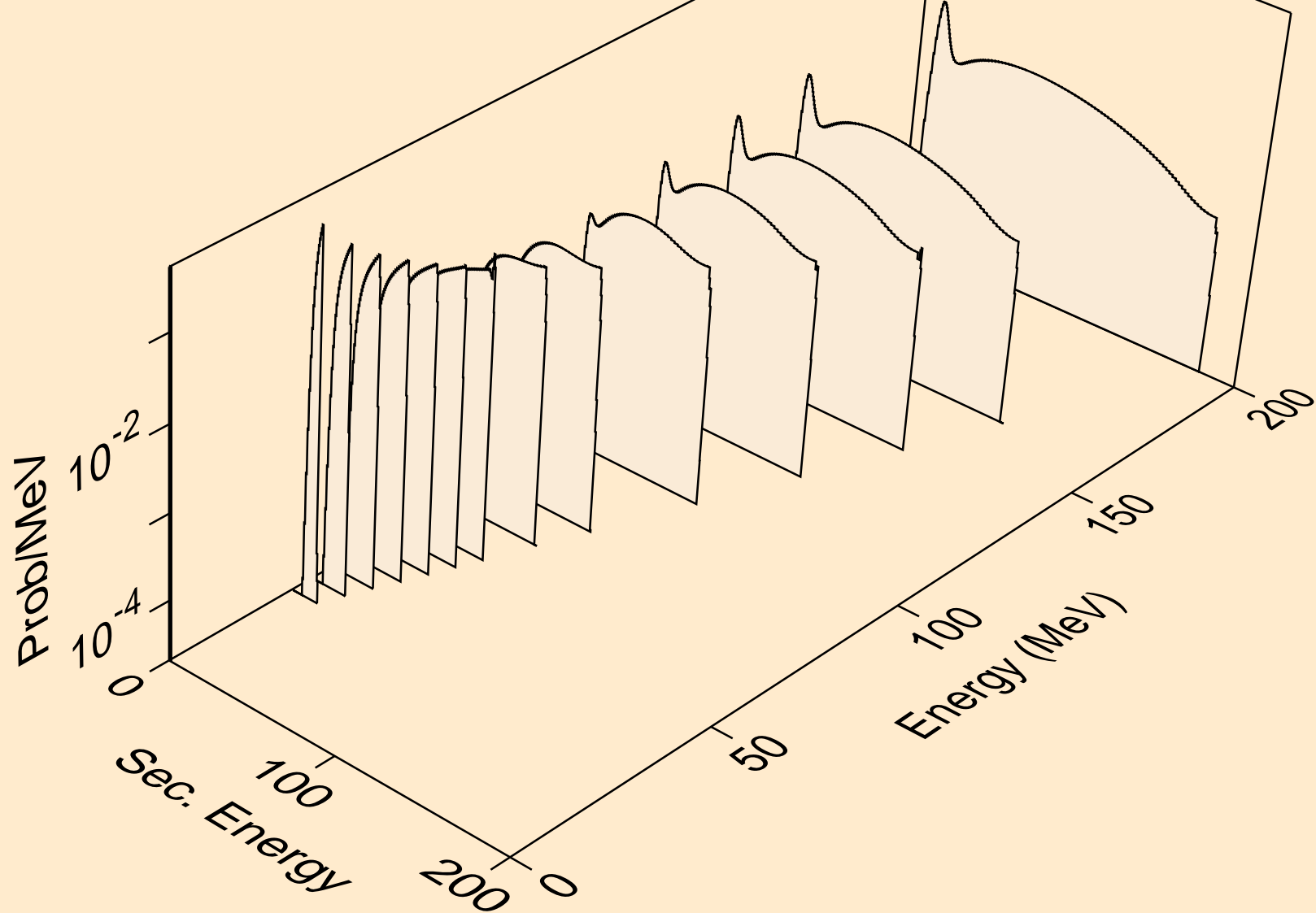

IR190 ALPHA ACER TENDL-2024 LIBRARY; T=0.K
tritons from (a,n*)t

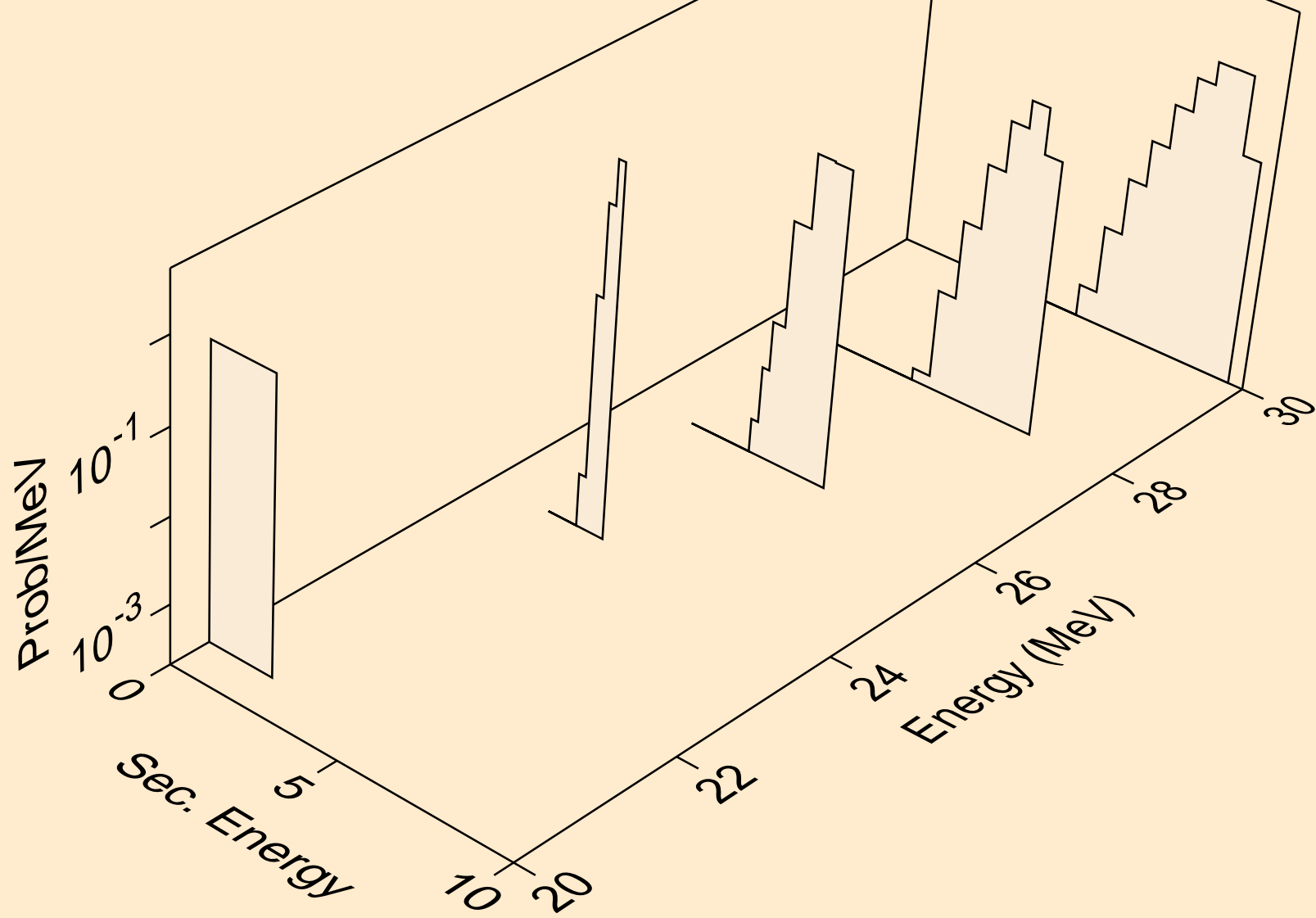

IR190 ALPHA ACER TENDL-2024 LIBRARY; T=0.K
tritons from (a,t)

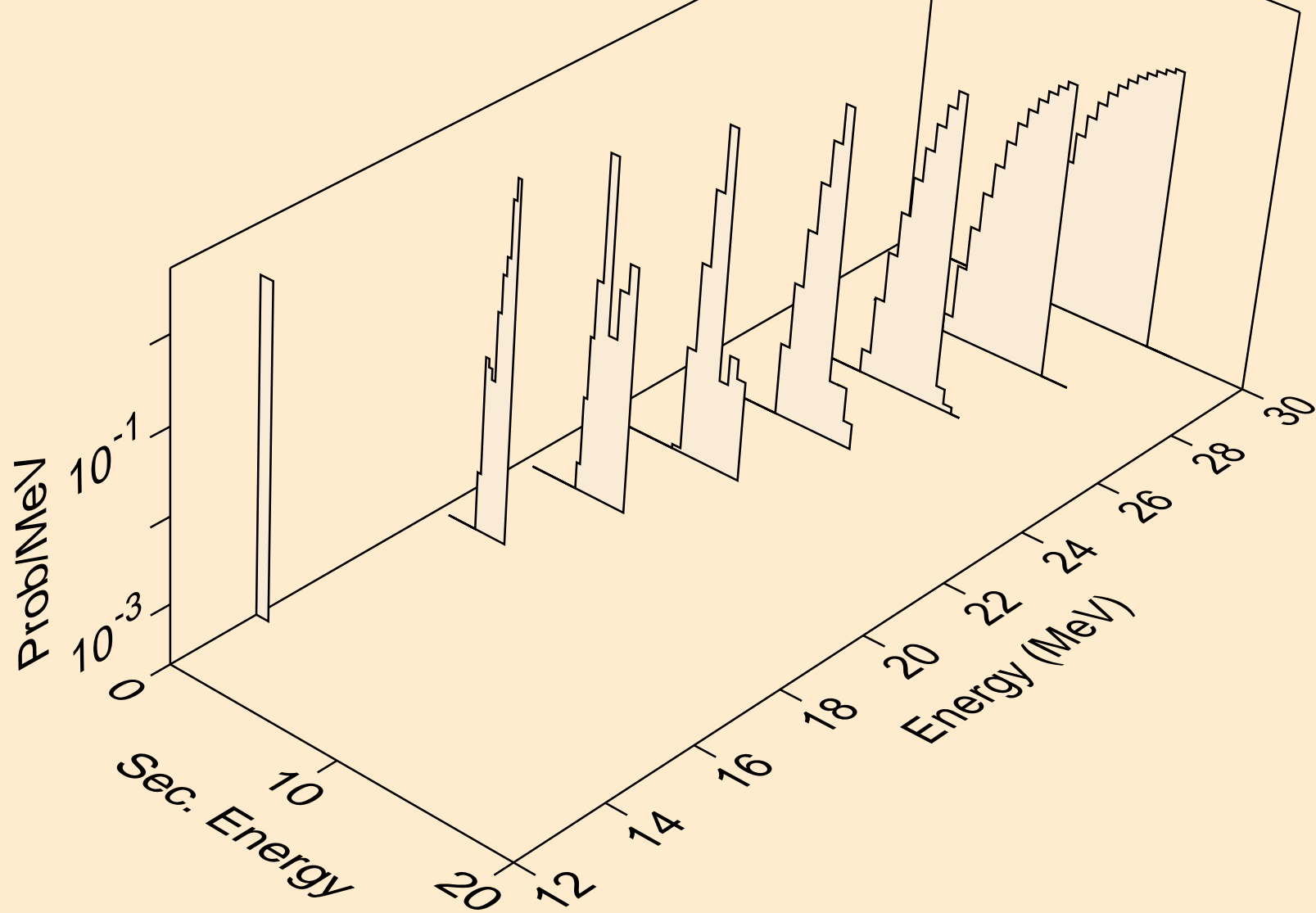

IR190 ALPHA ACER TENDL-2024 LIBRARY; T=0.K
he3s from (a,x)

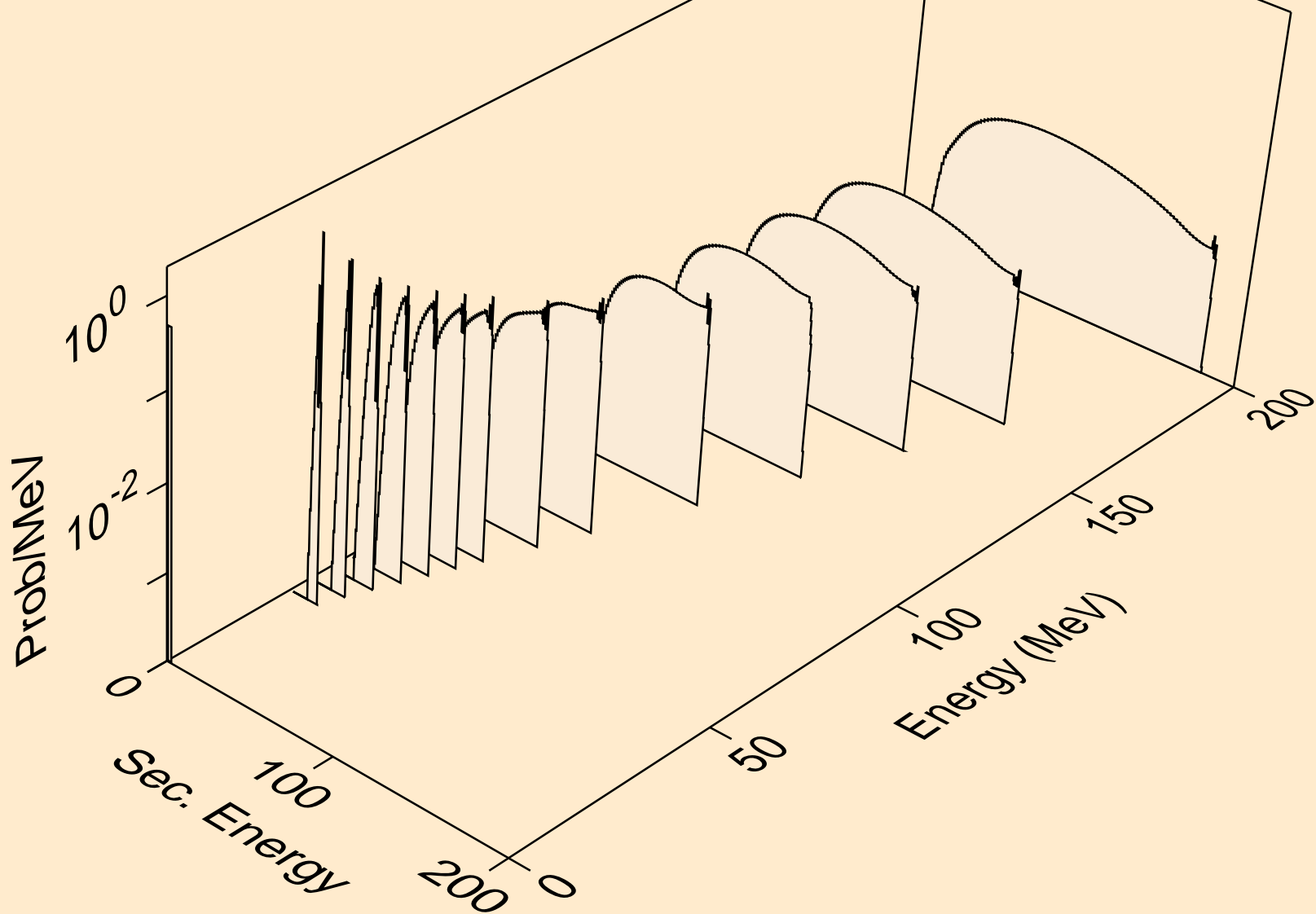

IR190 ALPHA ACER TENDL-2024 LIBRARY; T=0.K
he3s from (a,he3)

