

# K038 ALPHA ACER TENDL-2024 LIBRARY; T=0.K

## Principal cross sections

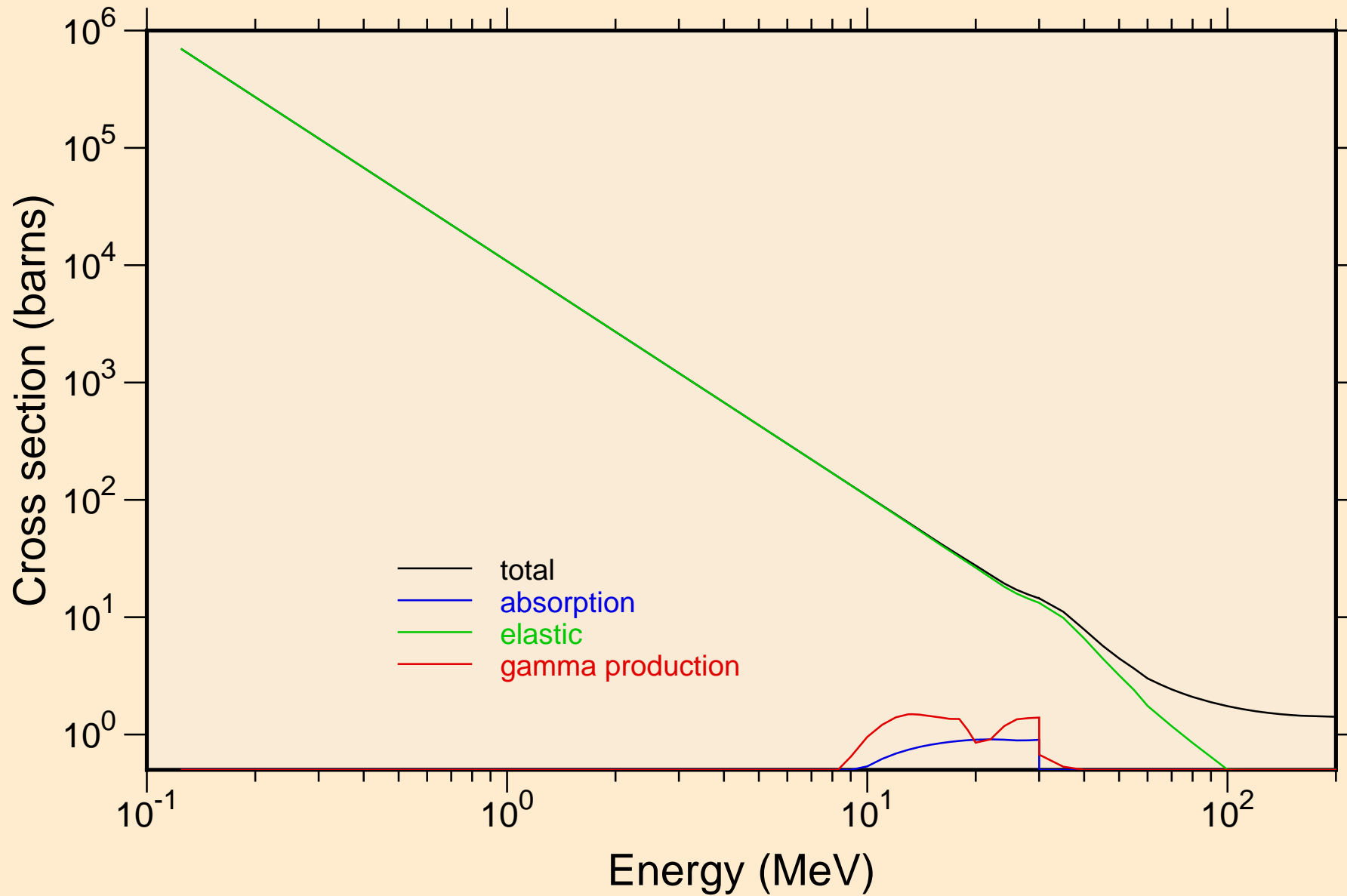

# K038 ALPHA ACER TENDL-2024 LIBRARY; T=0.K

## Heating

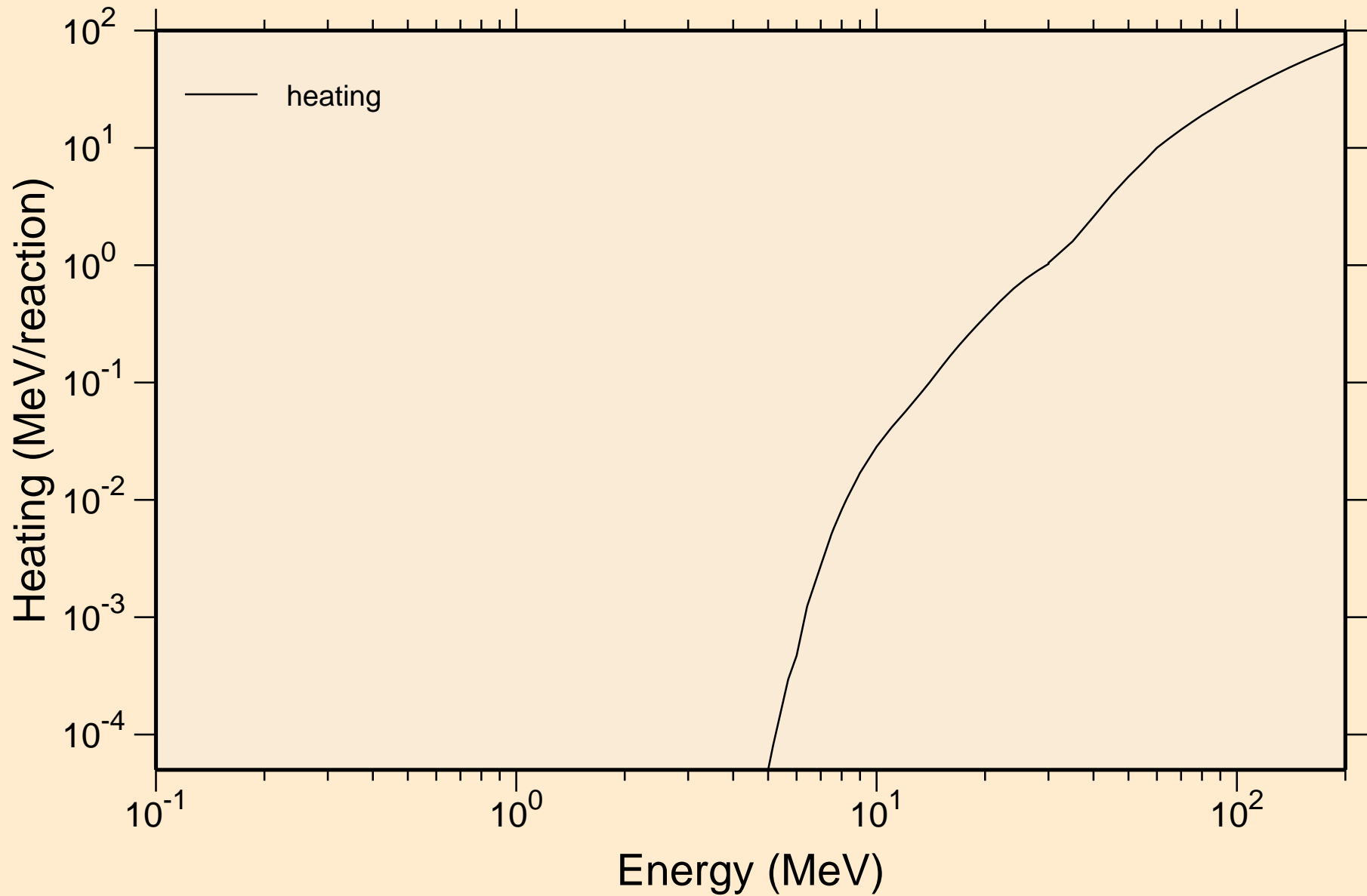

# K038 ALPHA ACER TENDL-2024 LIBRARY; T=0.K

## Principal cross sections

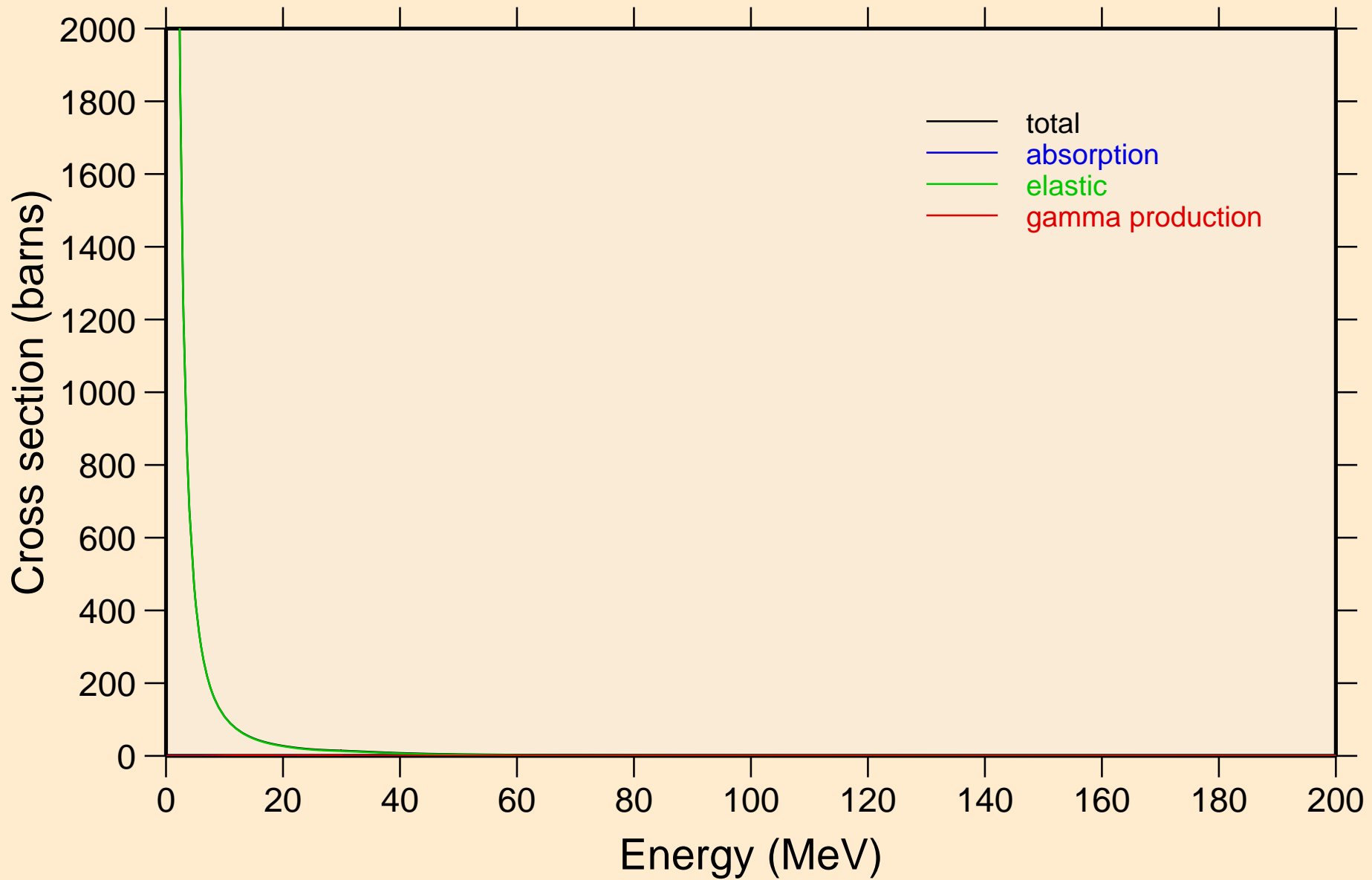

K038 ALPHA ACER TENDL-2024 LIBRARY; T=0.K

Heating

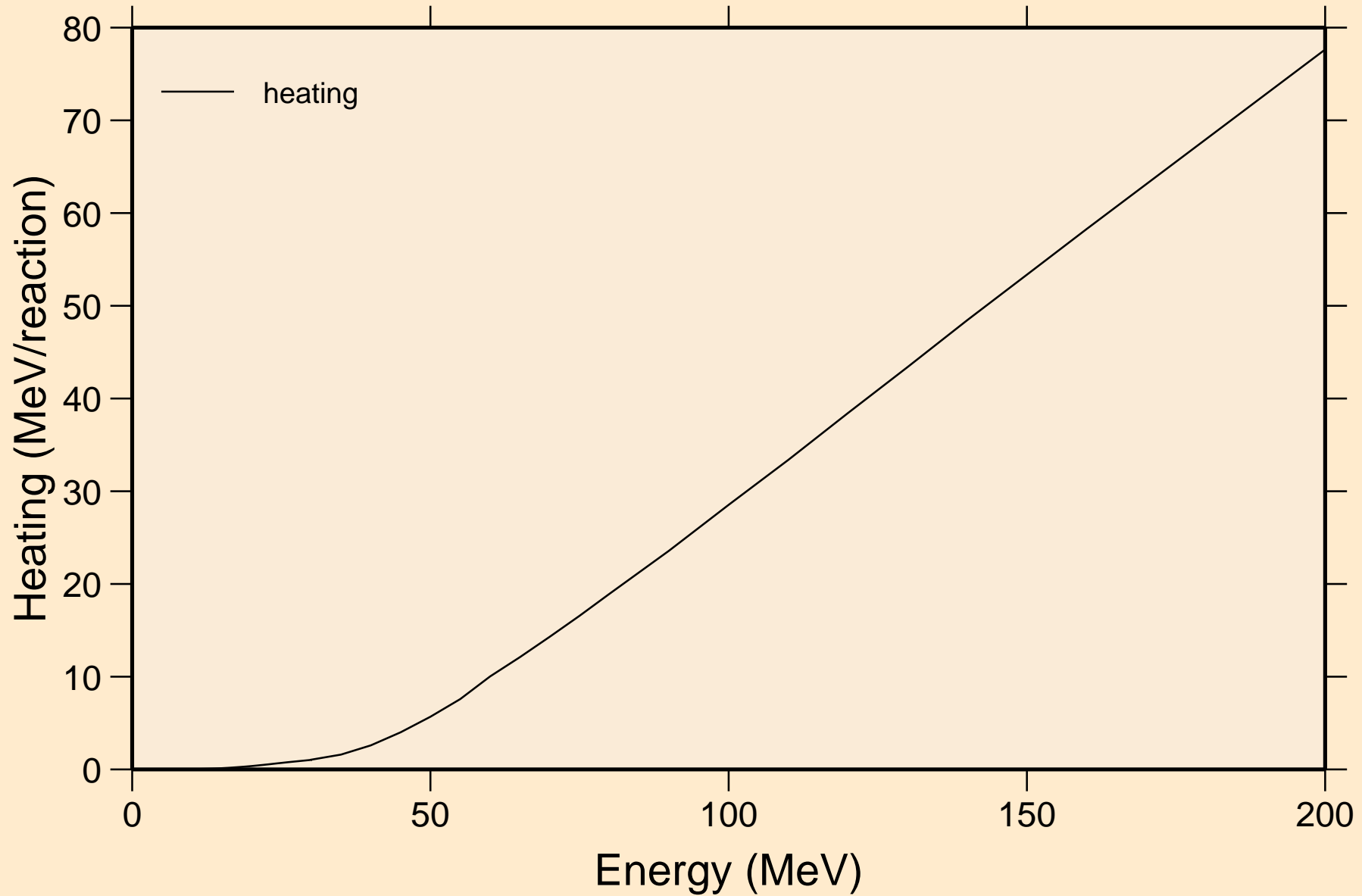

K038 ALPHA ACER TENDL-2024 LIBRARY; T=0.K  
Threshold reactions

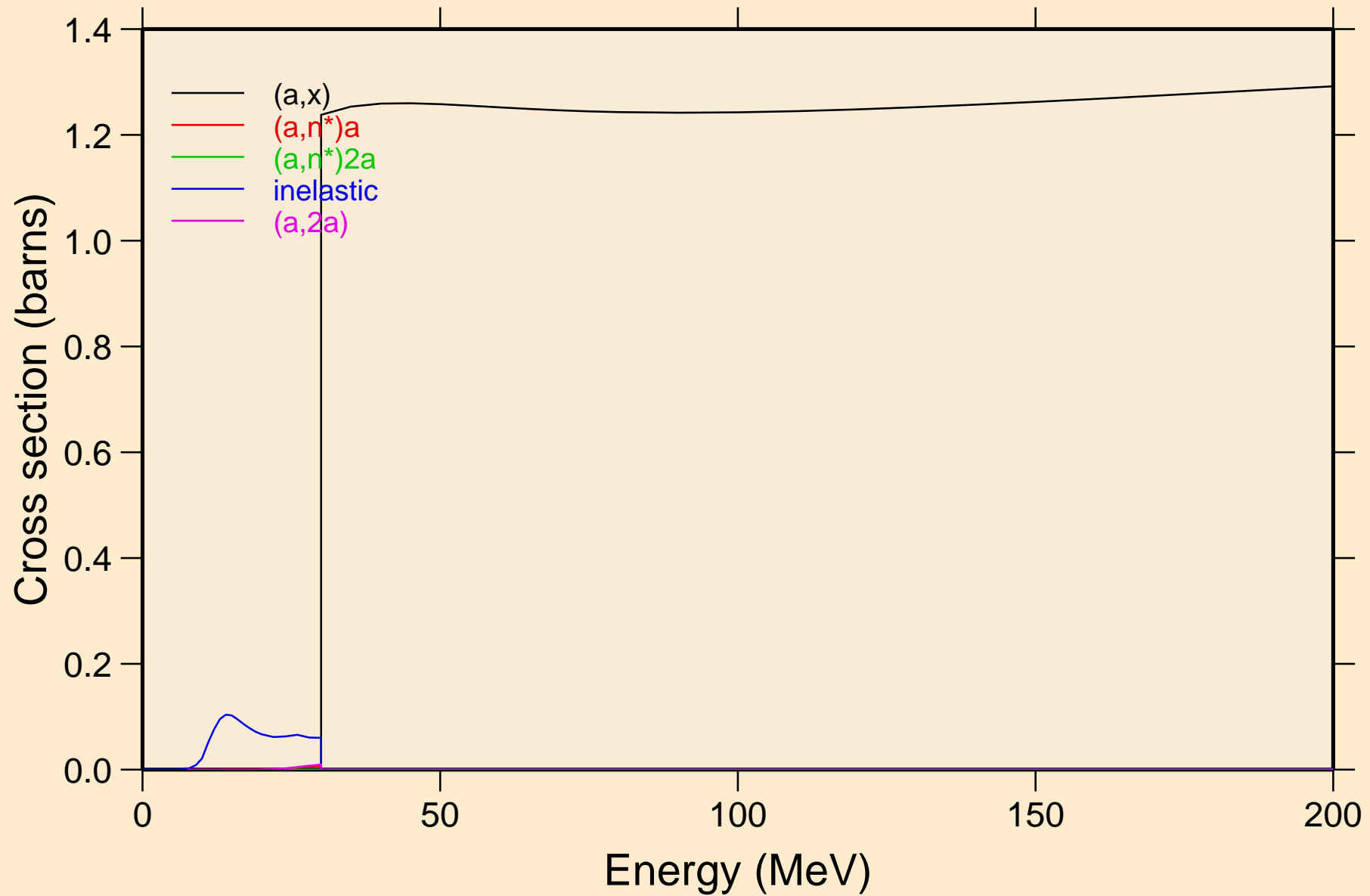

K038 ALPHA ACER TENDL-2024 LIBRARY; T=0.K  
Threshold reactions

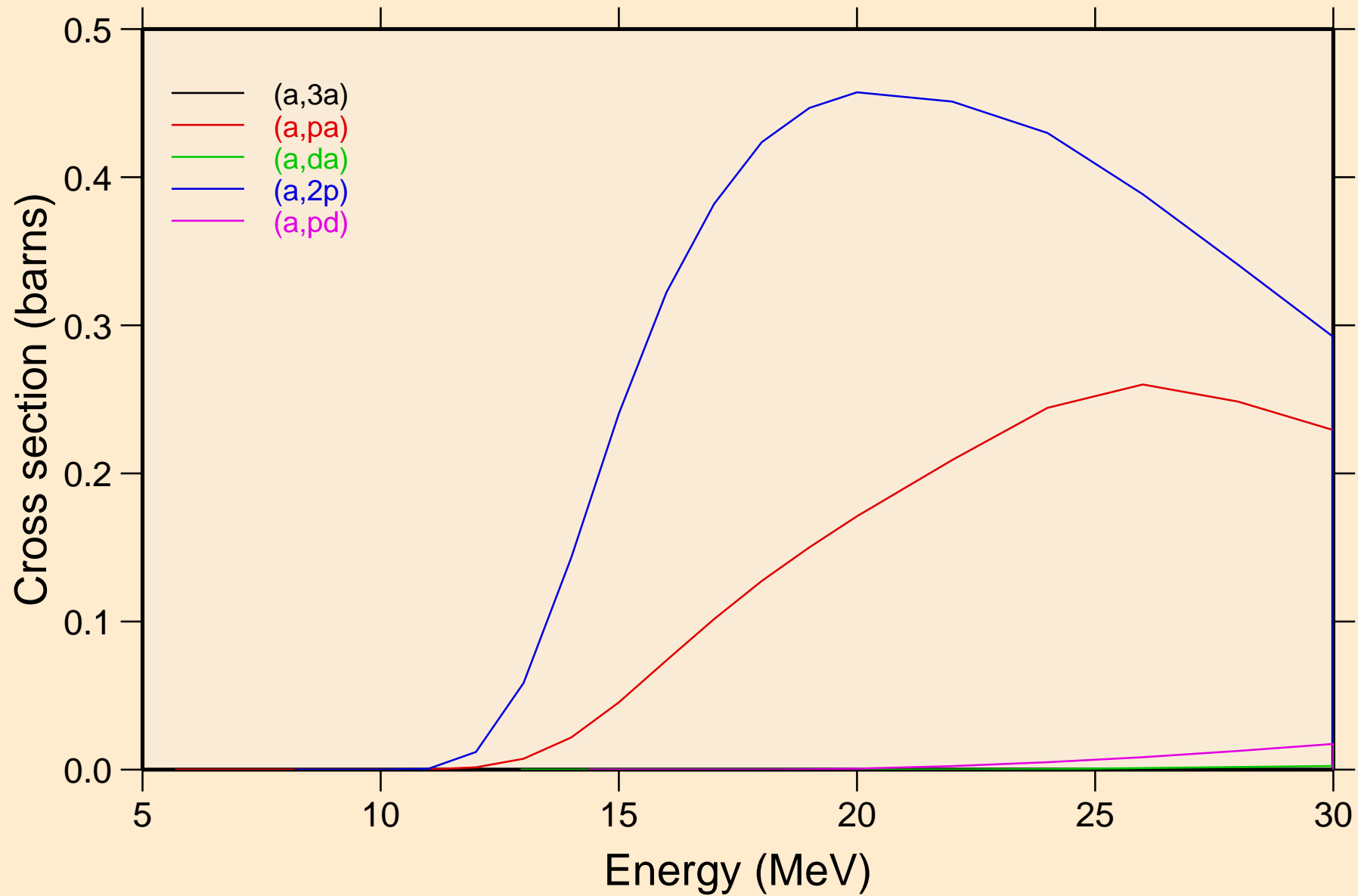

K038 ALPHA ACER TENDL-2024 LIBRARY; T=0.K  
Threshold reactions

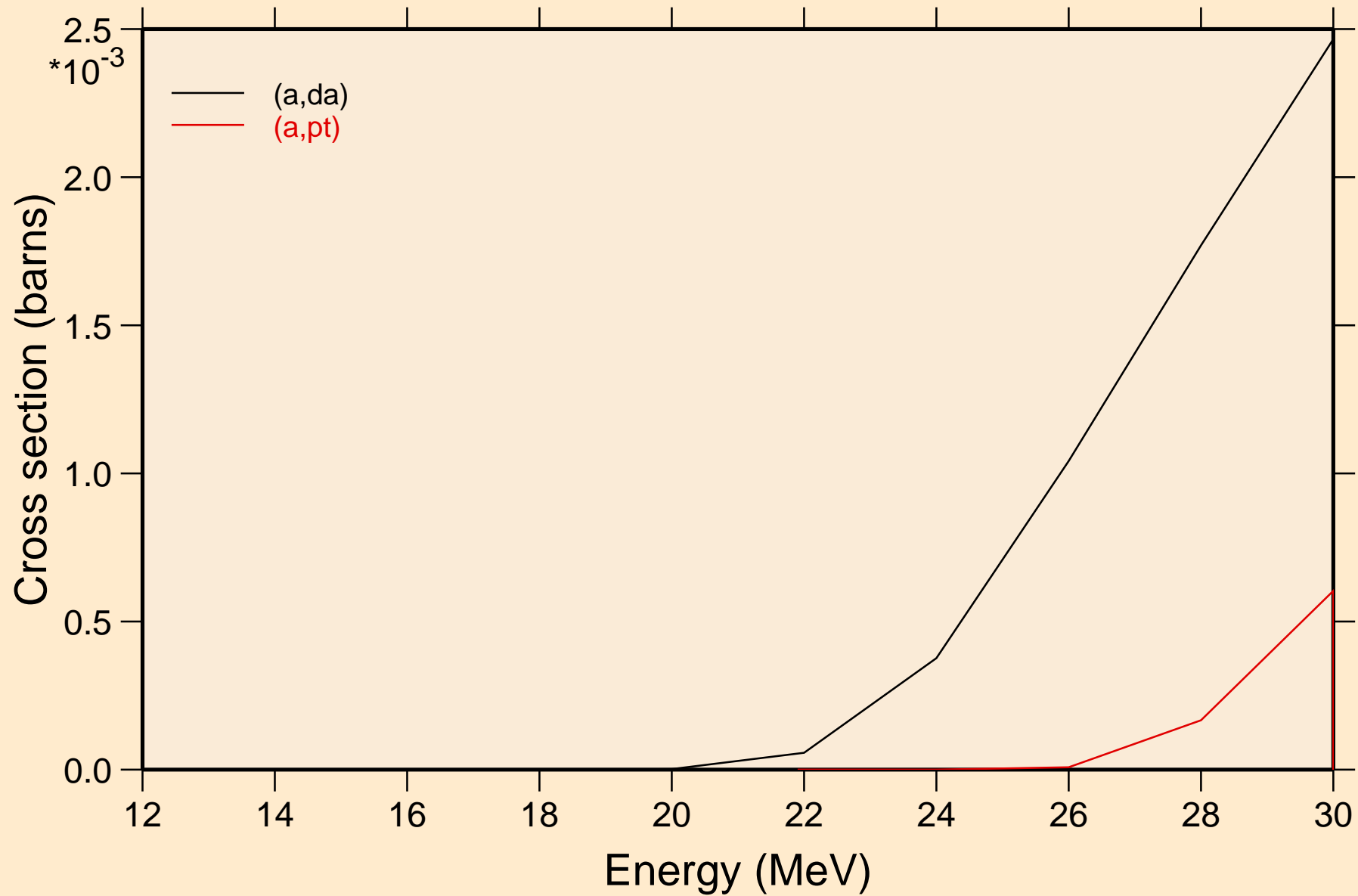

K038 ALPHA ACER TENDL-2024 LIBRARY; T=0.K  
Threshold reactions

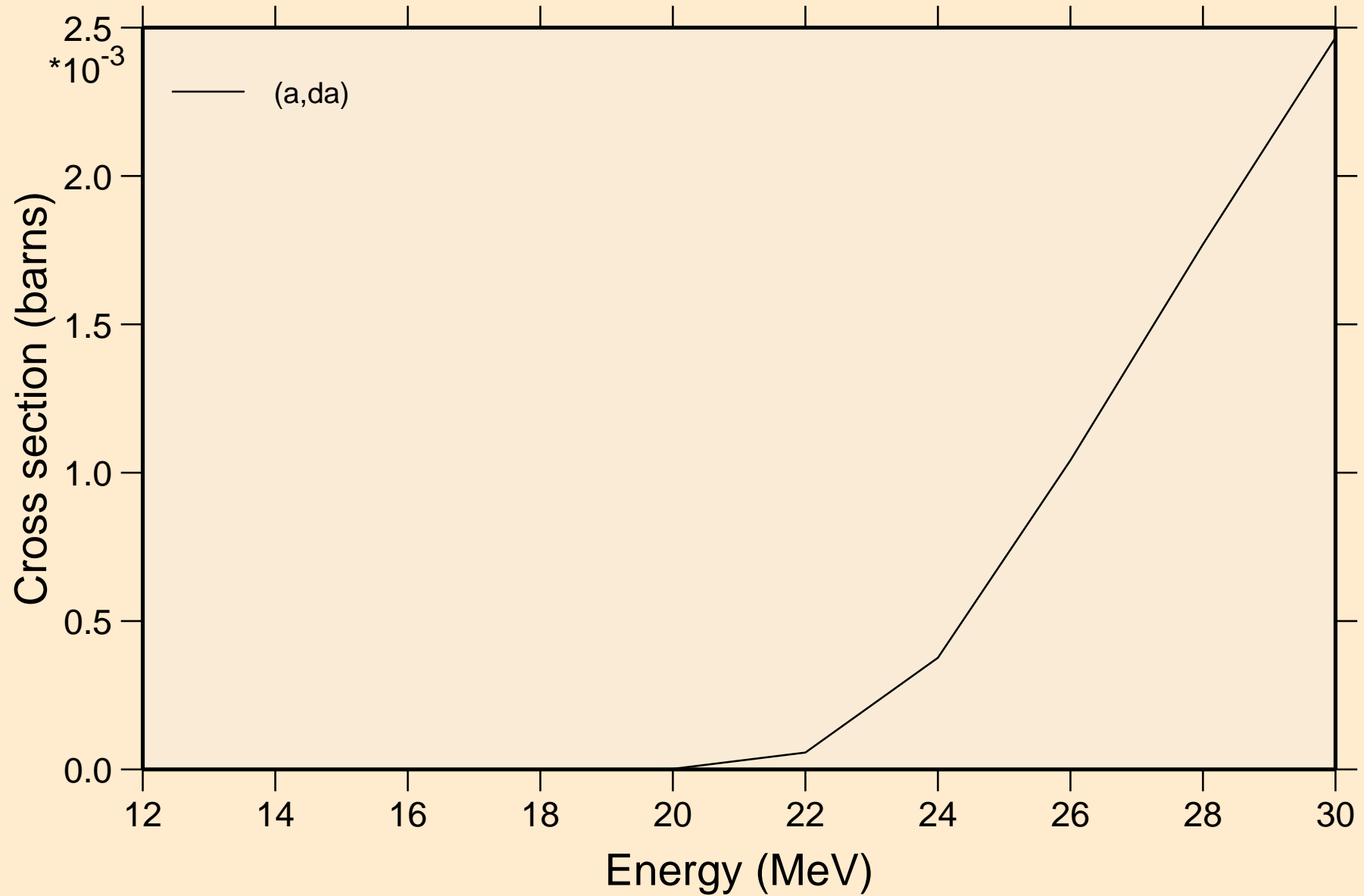

K038 ALPHA ACER TENDL-2024 LIBRARY; T=0.K  
angular distribution for elastic

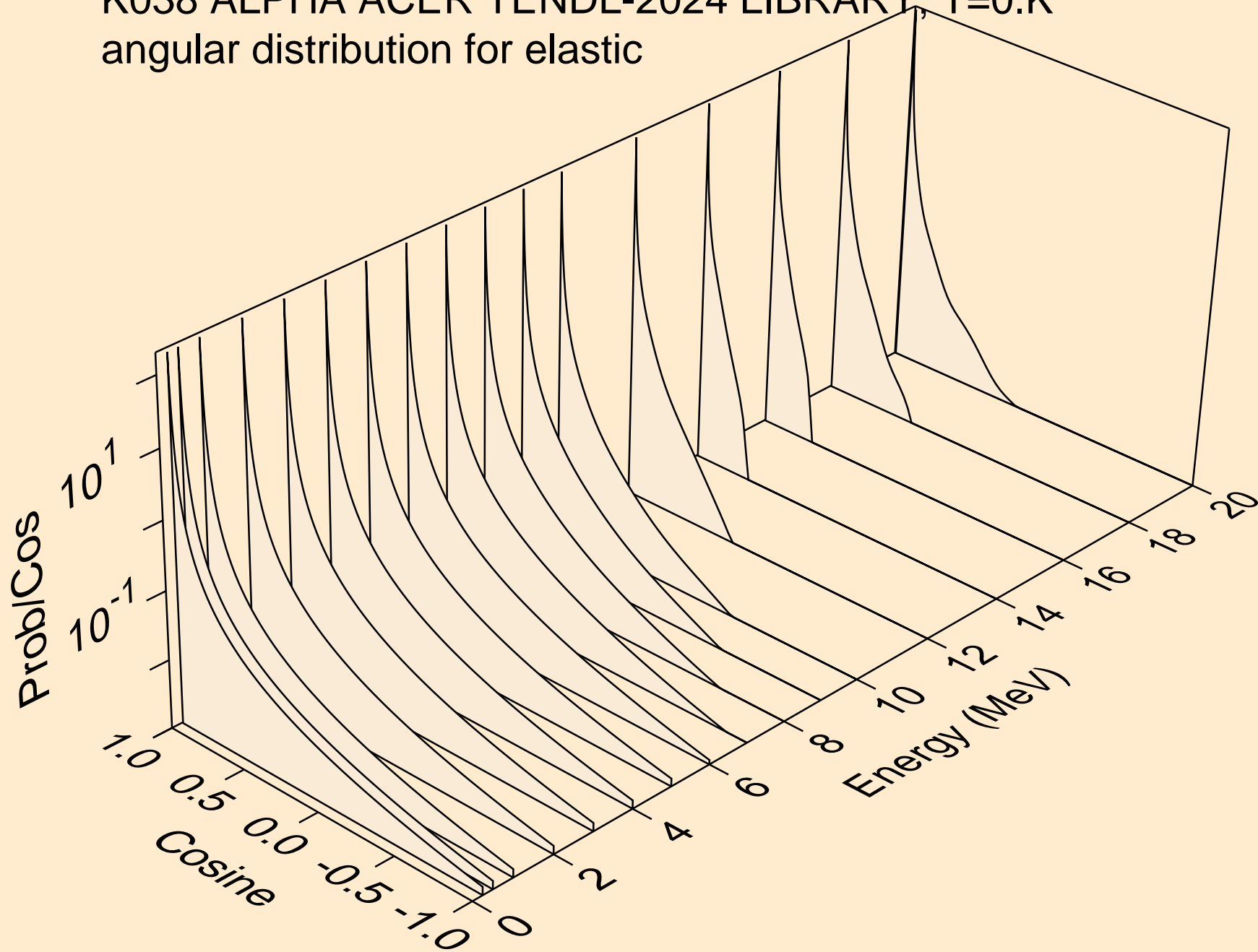

K038 ALPHA ACER TENDL-2024 LIBRARY: T=0.K  
angular distribution for elastic

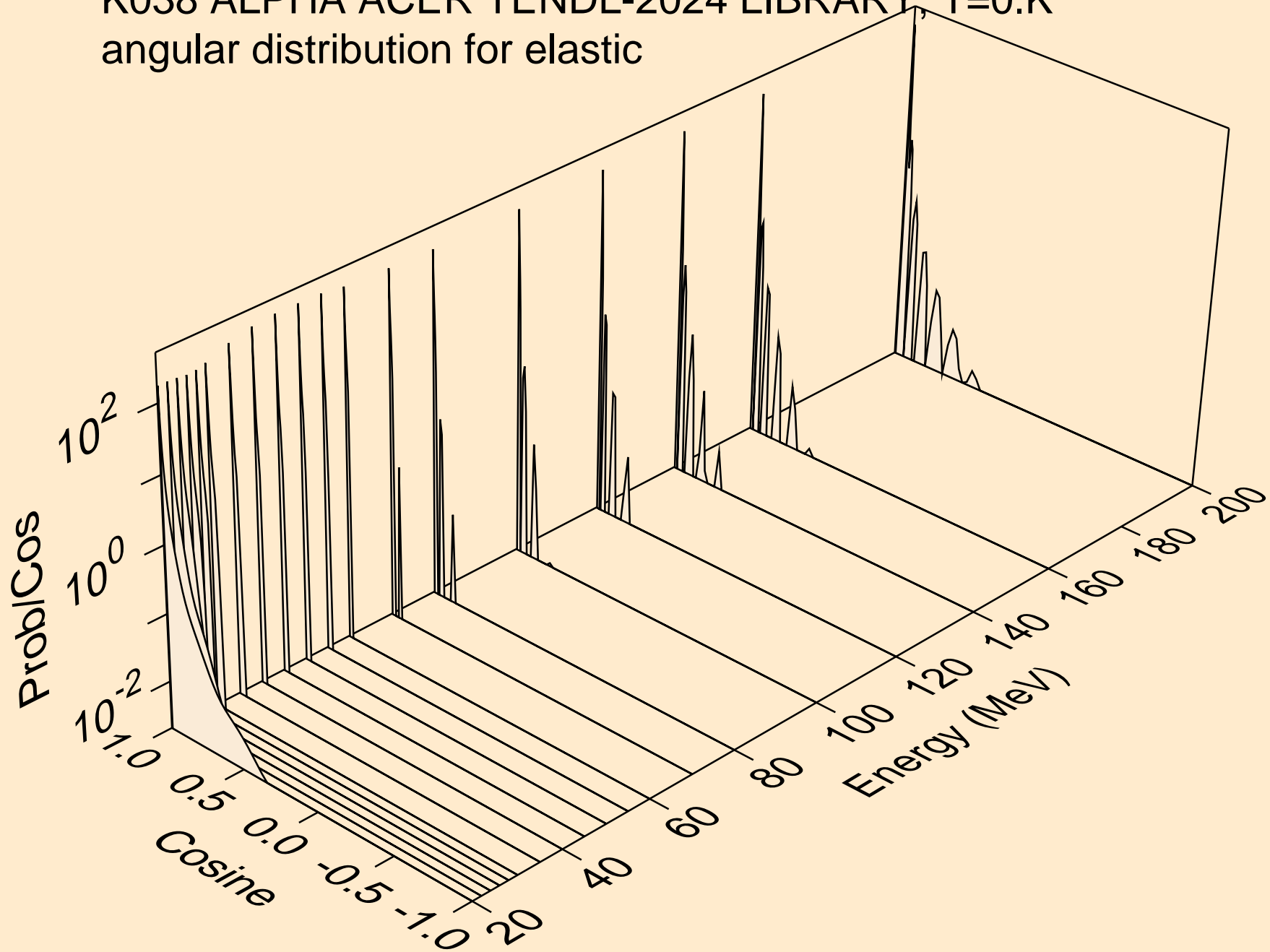

K038 ALPHA ACER TENDL-2024 LIBRARY; T=0.K  
Alpha emission for (a,x)

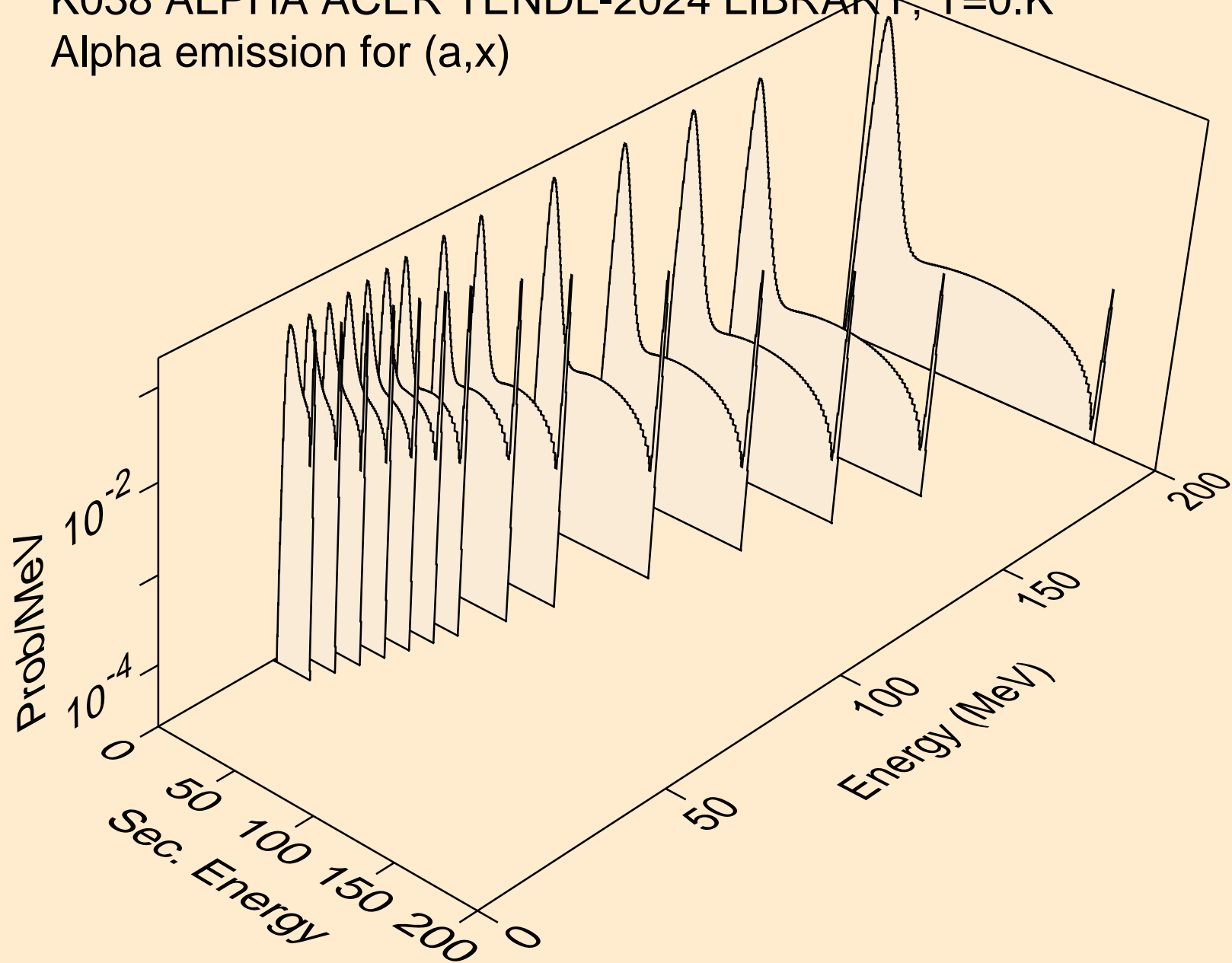

K038 ALPHA ACER TENDL-2024 LIBRARY; T=0.K  
Alpha emission for (a,n\*)a

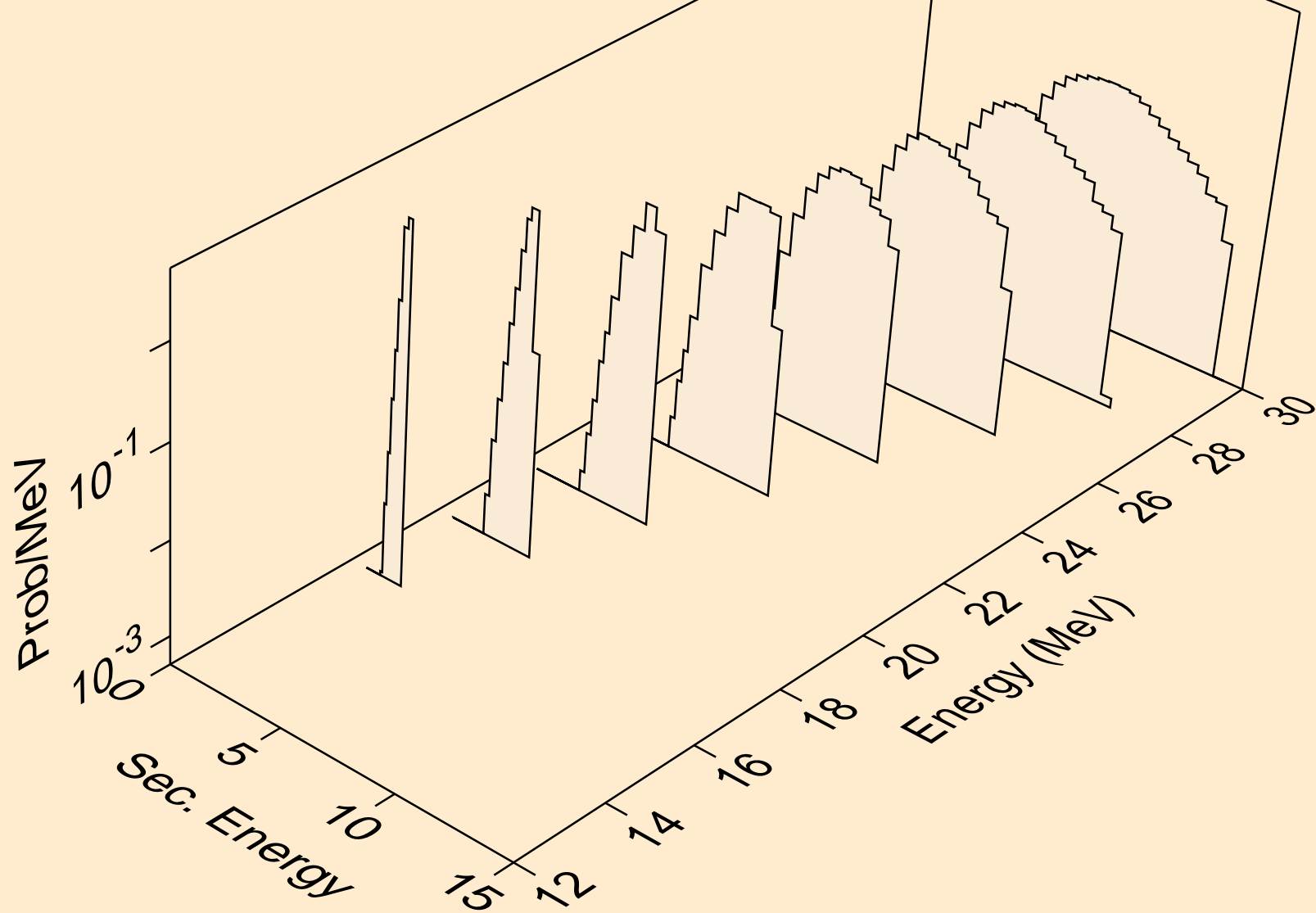

K038 ALPHA ACER TENDL-2024 LIBRARY; T=0.K  
Alpha emission for (a,n\*)2a

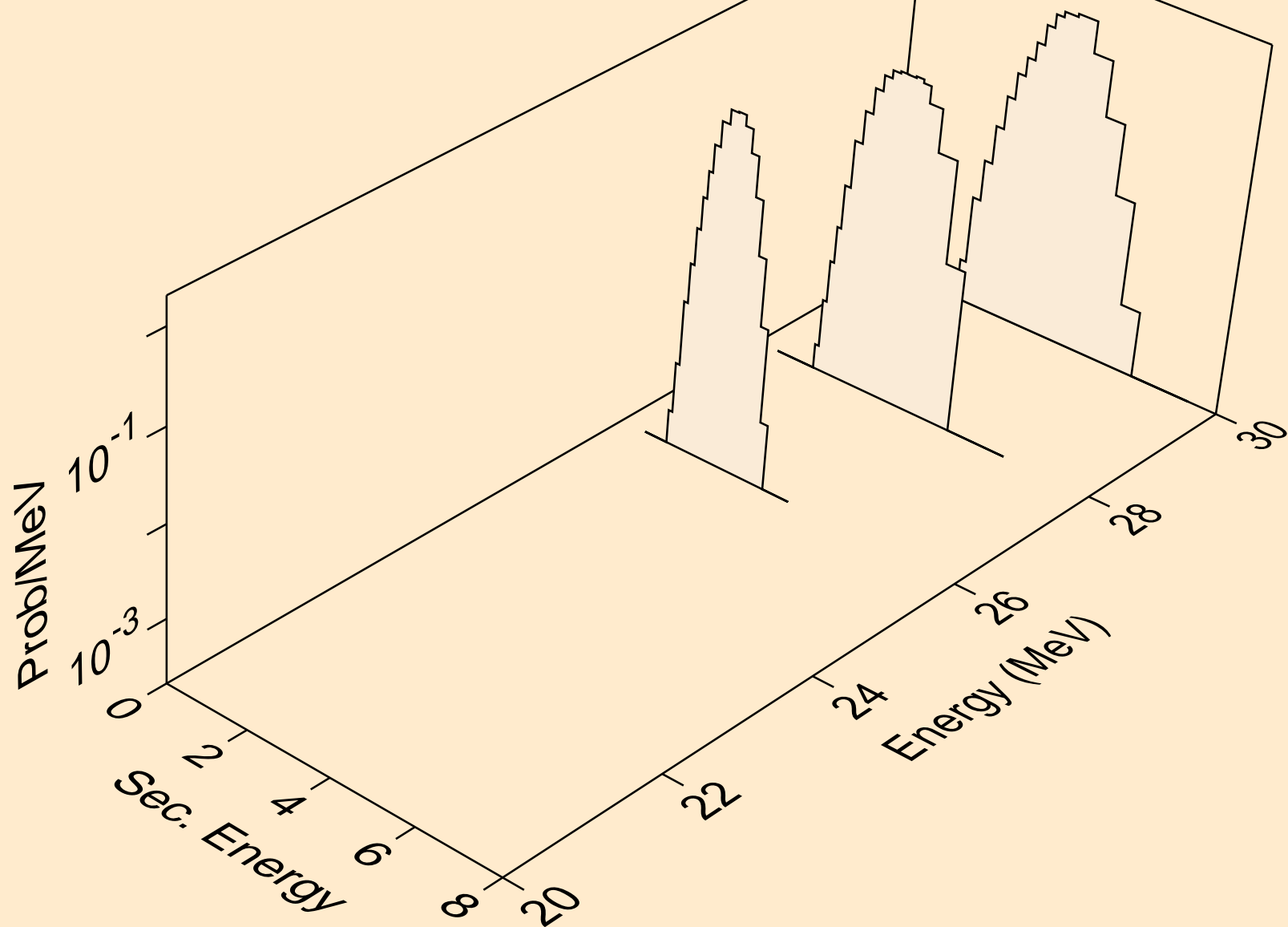

K038 ALPHA ACER TENDL-2024 LIBRARY; T=0.K  
Alpha emission for inelastic

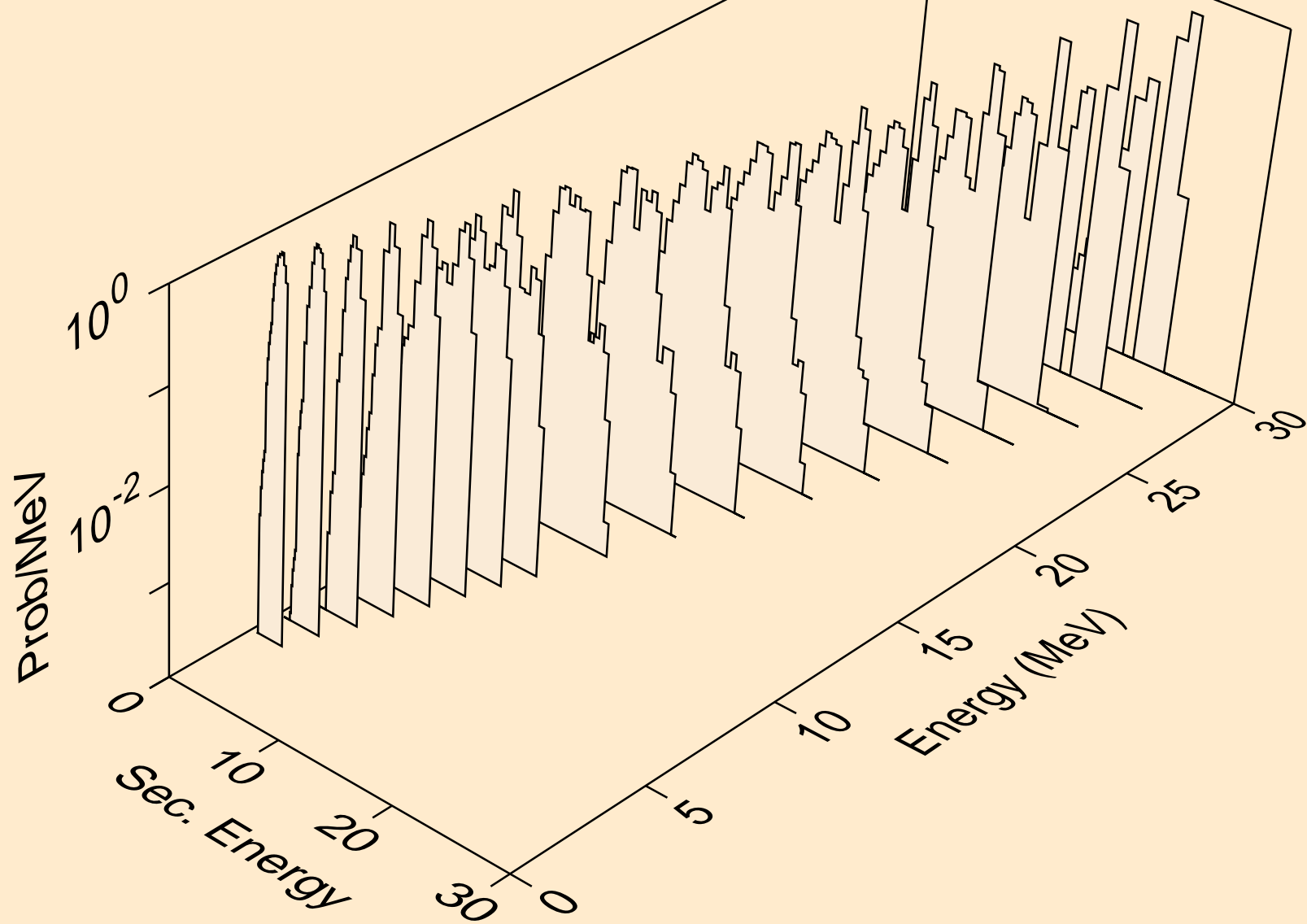

K038 ALPHA ACER TENDL-2024 LIBRARY; T=0.K  
Alpha emission for (a,2a)

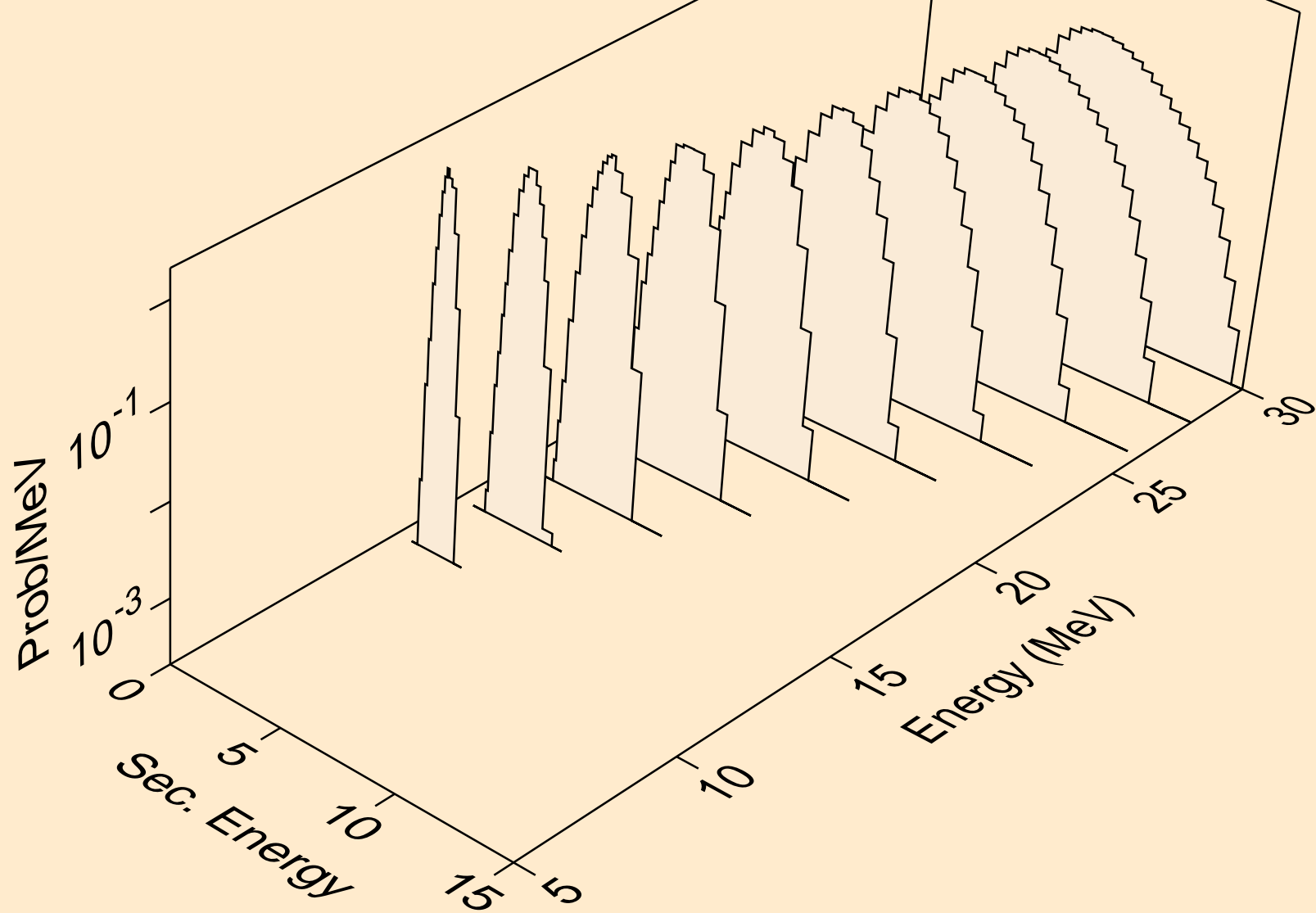

K038 ALPHA ACER TENDL-2024 LIBRARY; T=0.K  
Alpha emission for (a,3a)

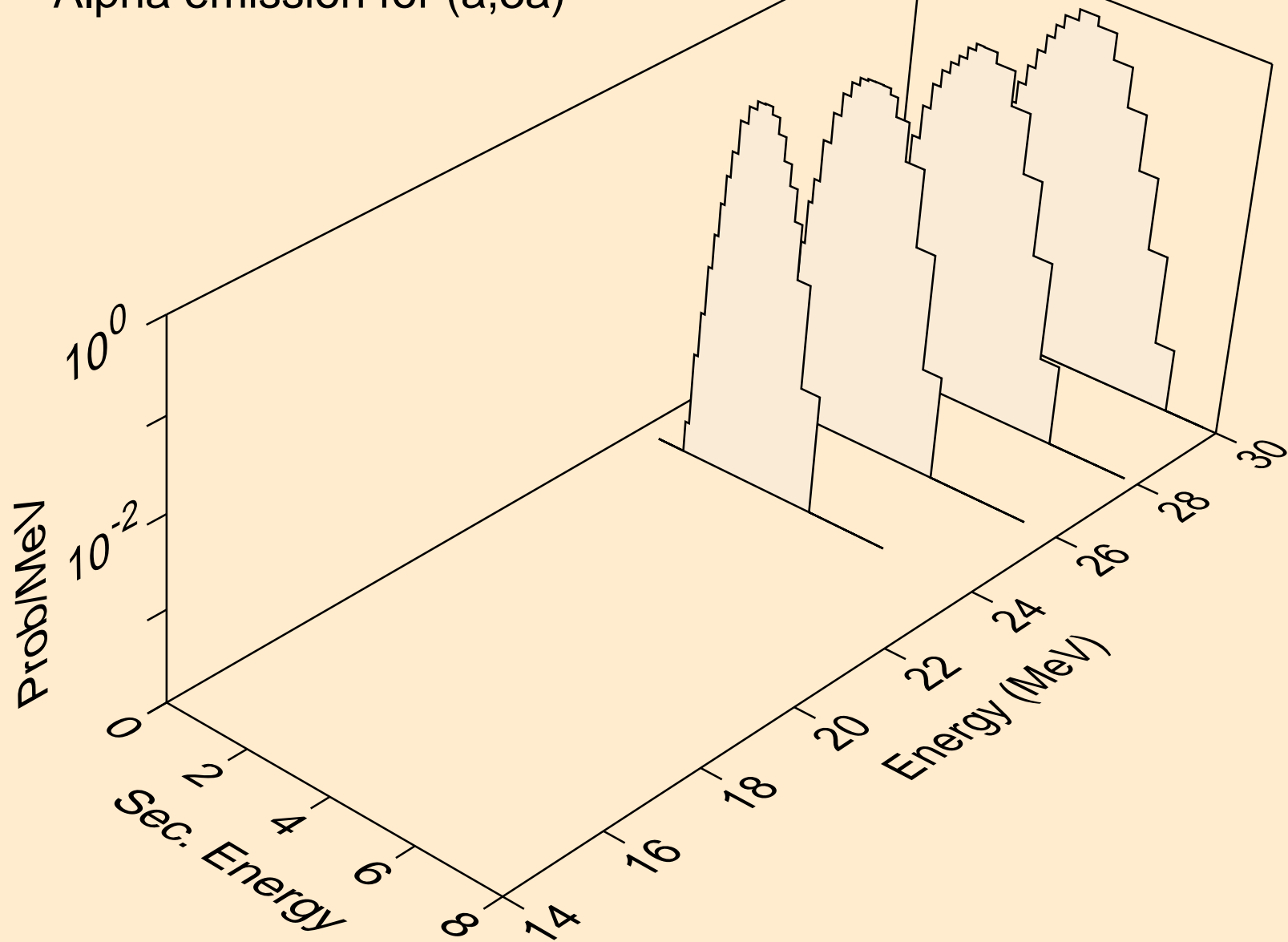

K038 ALPHA ACER TENDL-2024 LIBRARY; T=0.K  
Alpha emission for (a,pa)

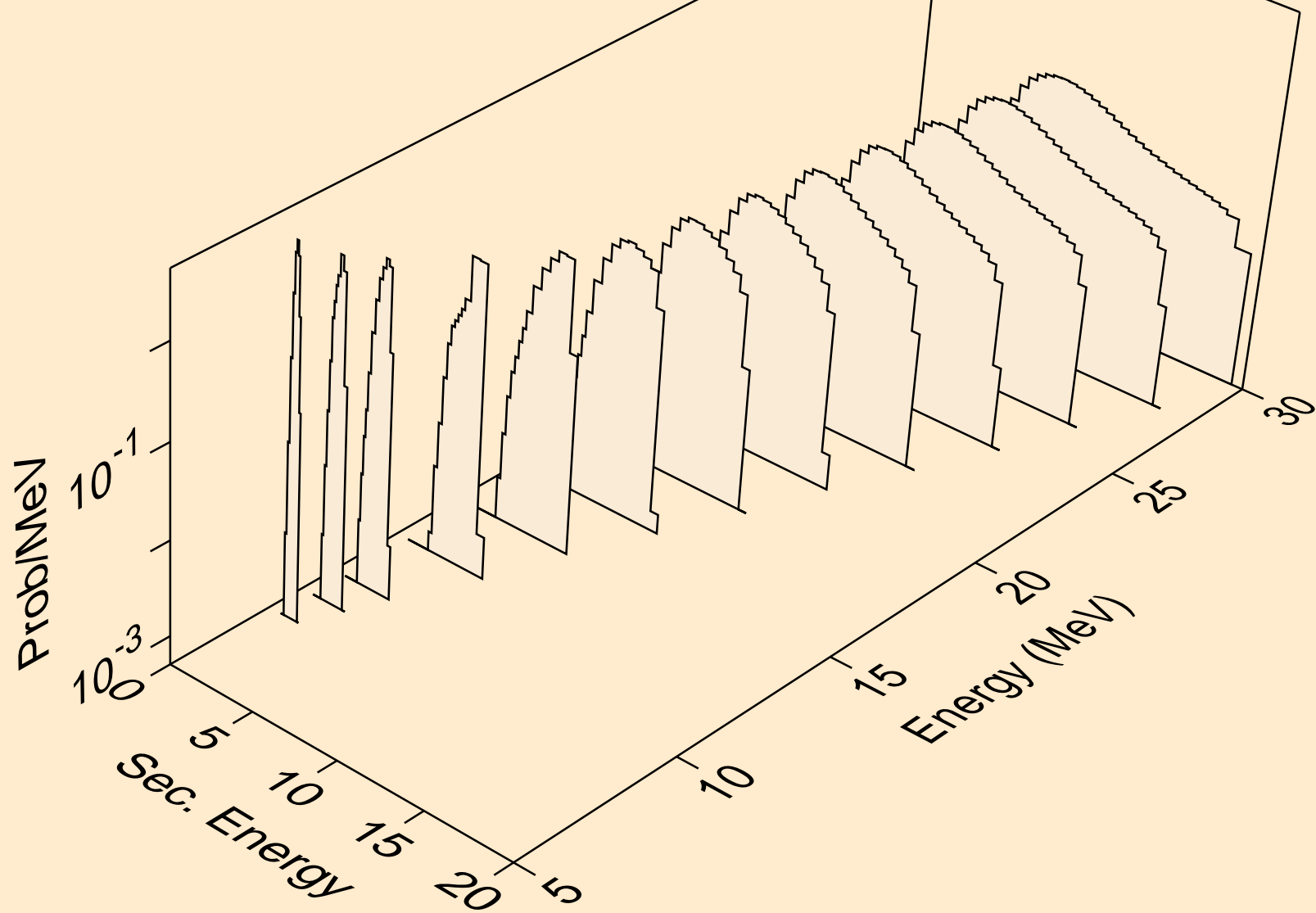

K038 ALPHA ACER TENDL-2024 LIBRARY; T=0.K  
Alpha emission for (a,da)

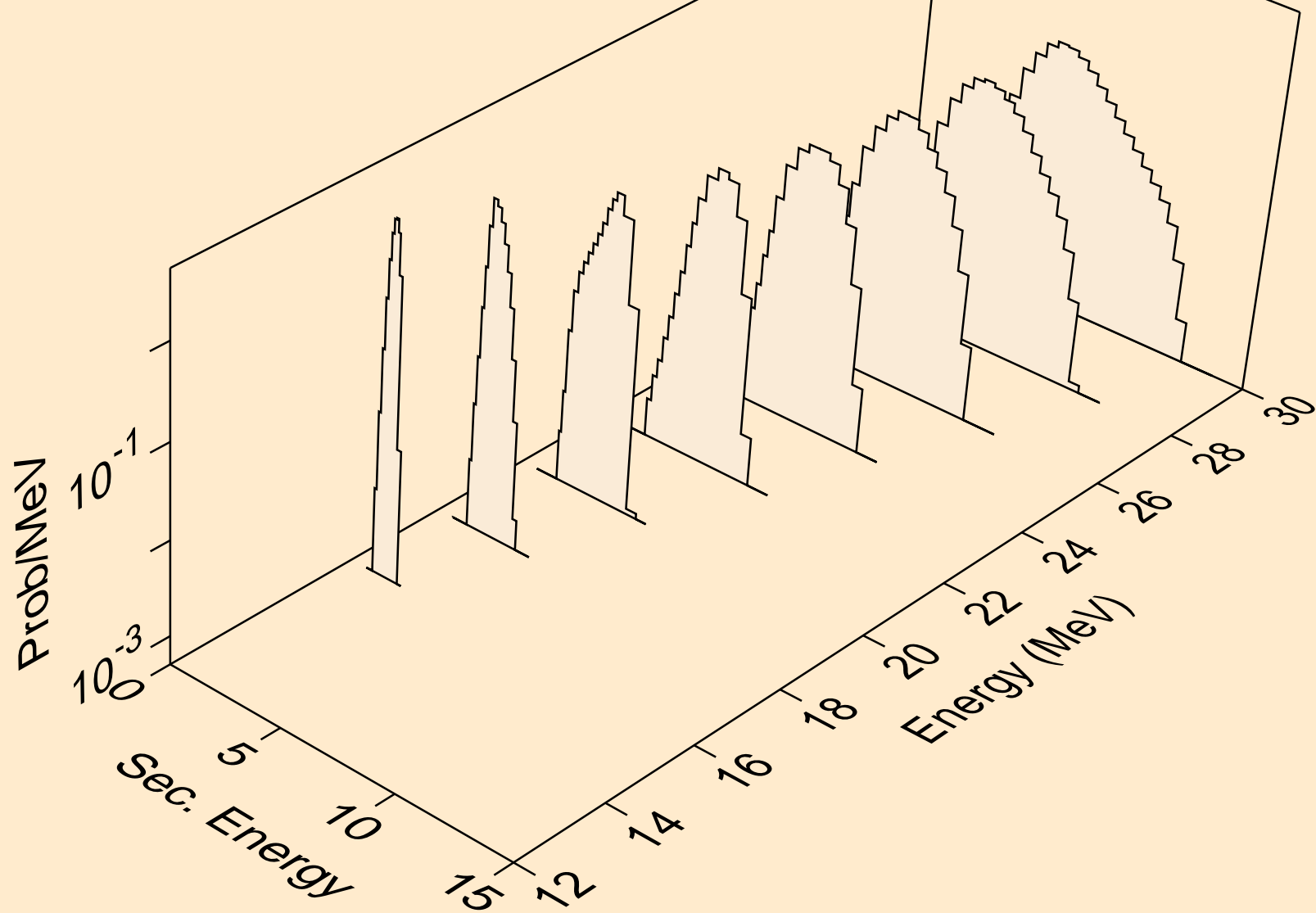

K038 ALPHA ACER TENDL-2024 LIBRARY; T=0.K  
Photon emission for (z,n)

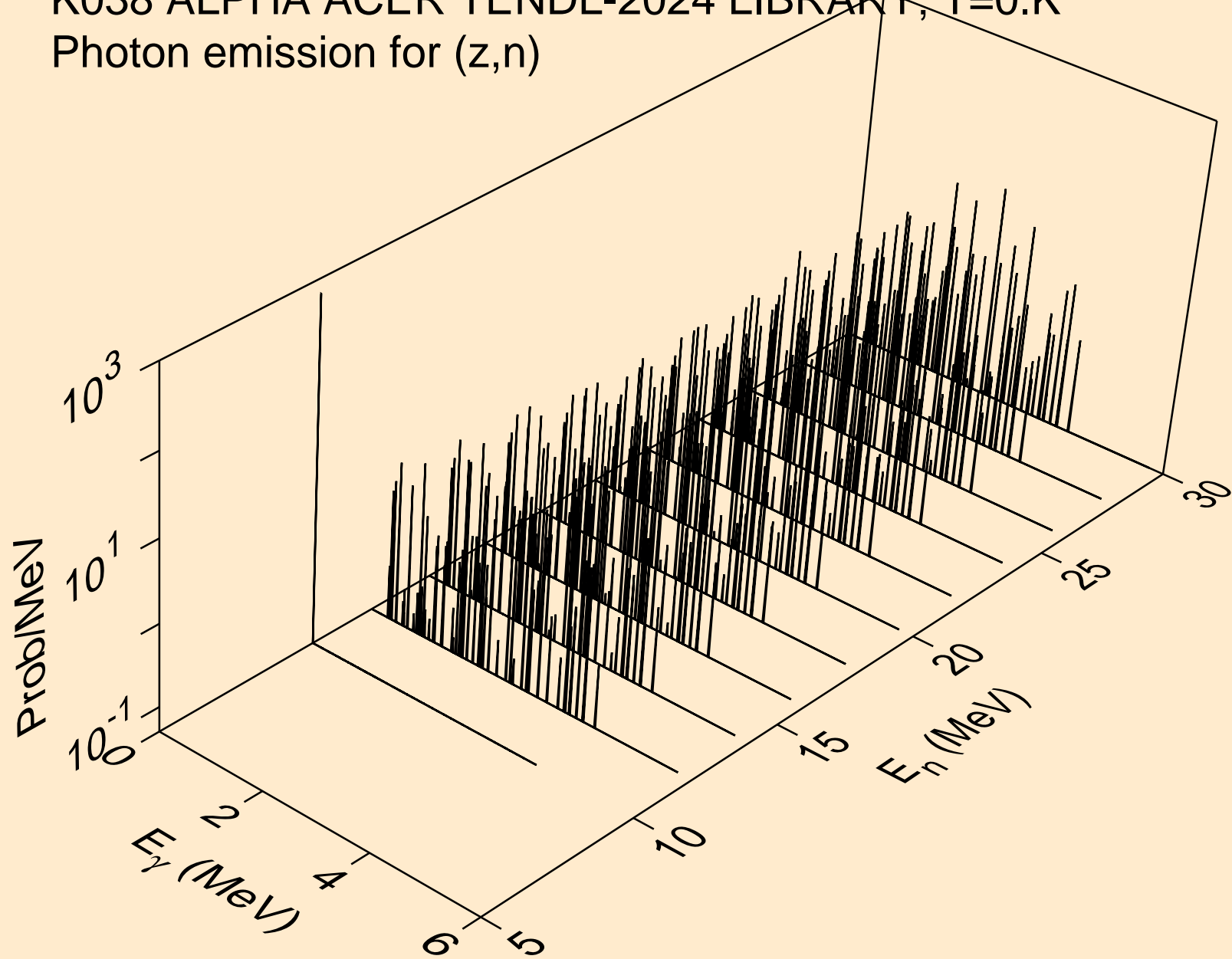

K038 ALPHA ACER TENDL-2024 LIBRARY; T=0.K  
Photon emission for (z,x)

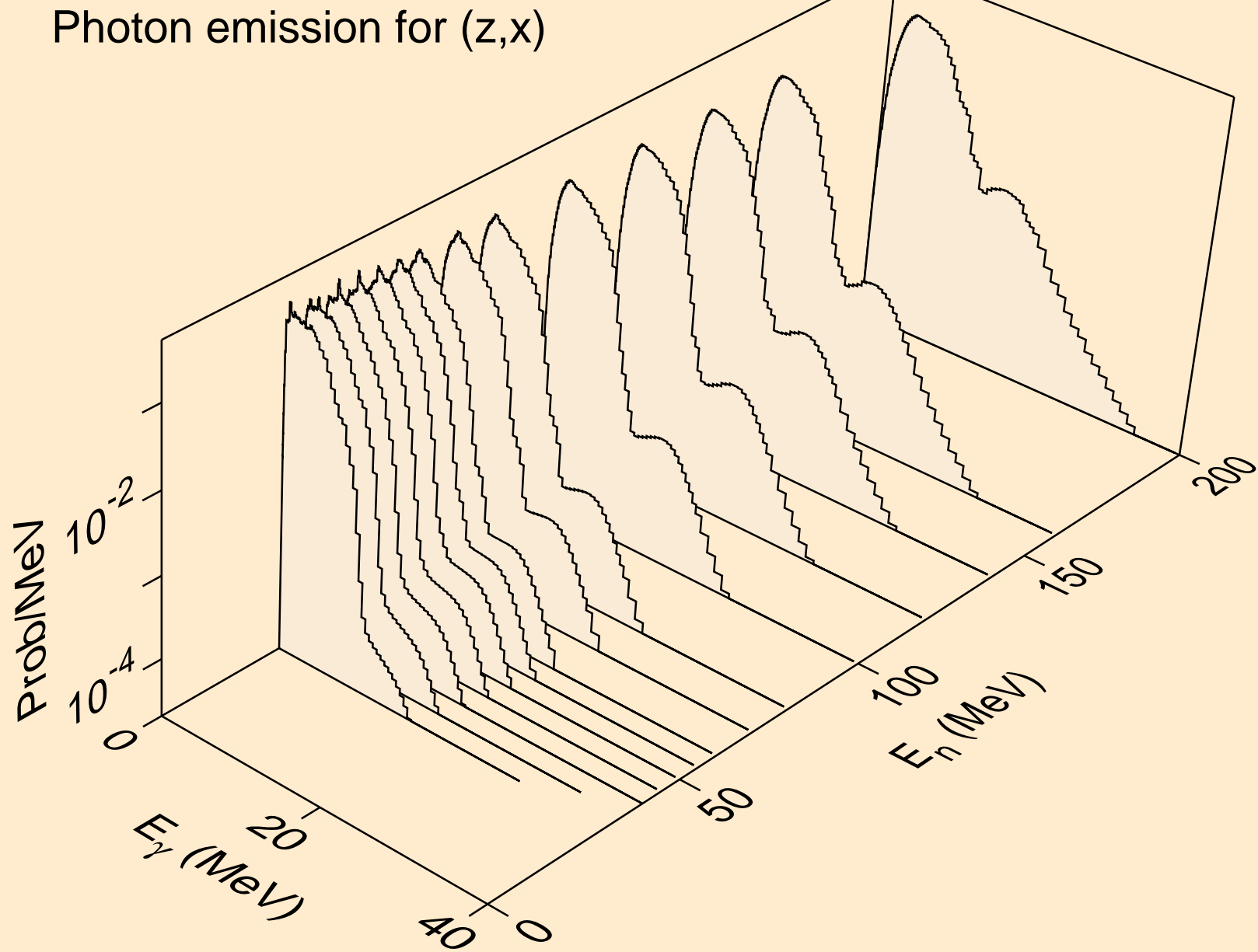

K038 ALPHA ACER TENDL-2024 LIBRARY; T=0.K  
Photon emission for (n,2n)

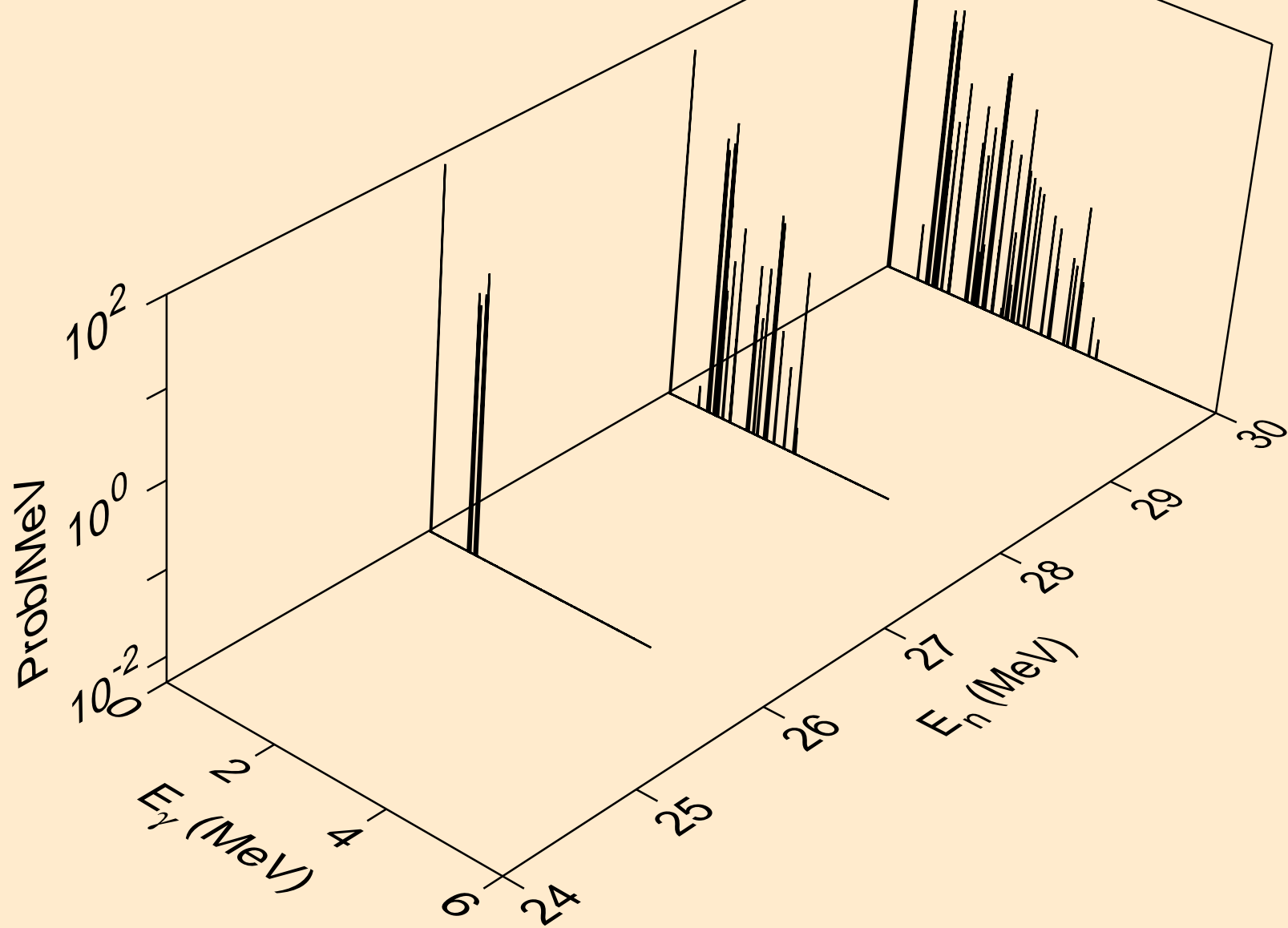

K038 ALPHA ACER TENDL-2024 LIBRARY; T=0.K  
Photon emission for (n,n\*)a

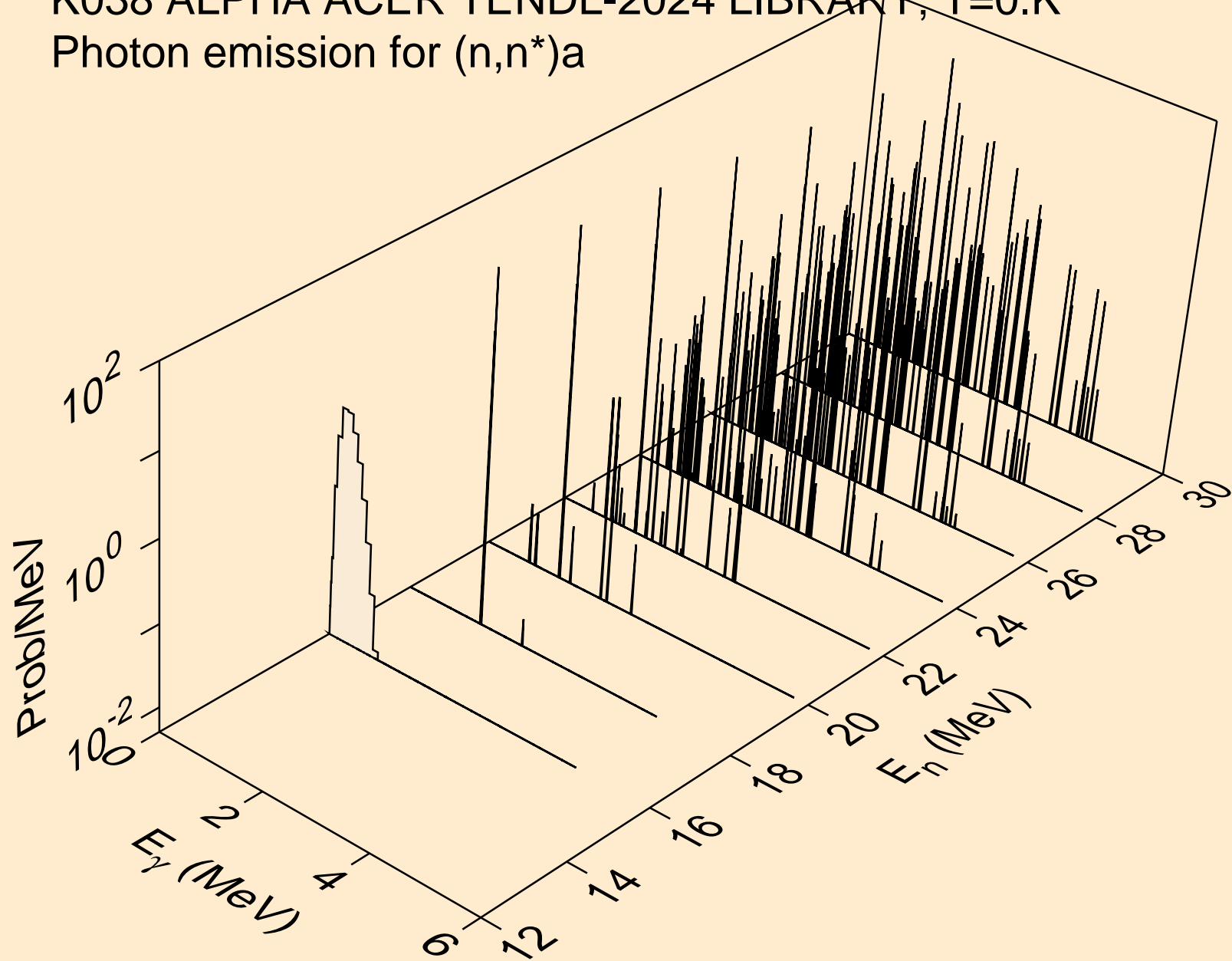

K038 ALPHA ACER TENDL-2024 LIBRARY; T=0.K  
Photon emission for (n,n\*)p

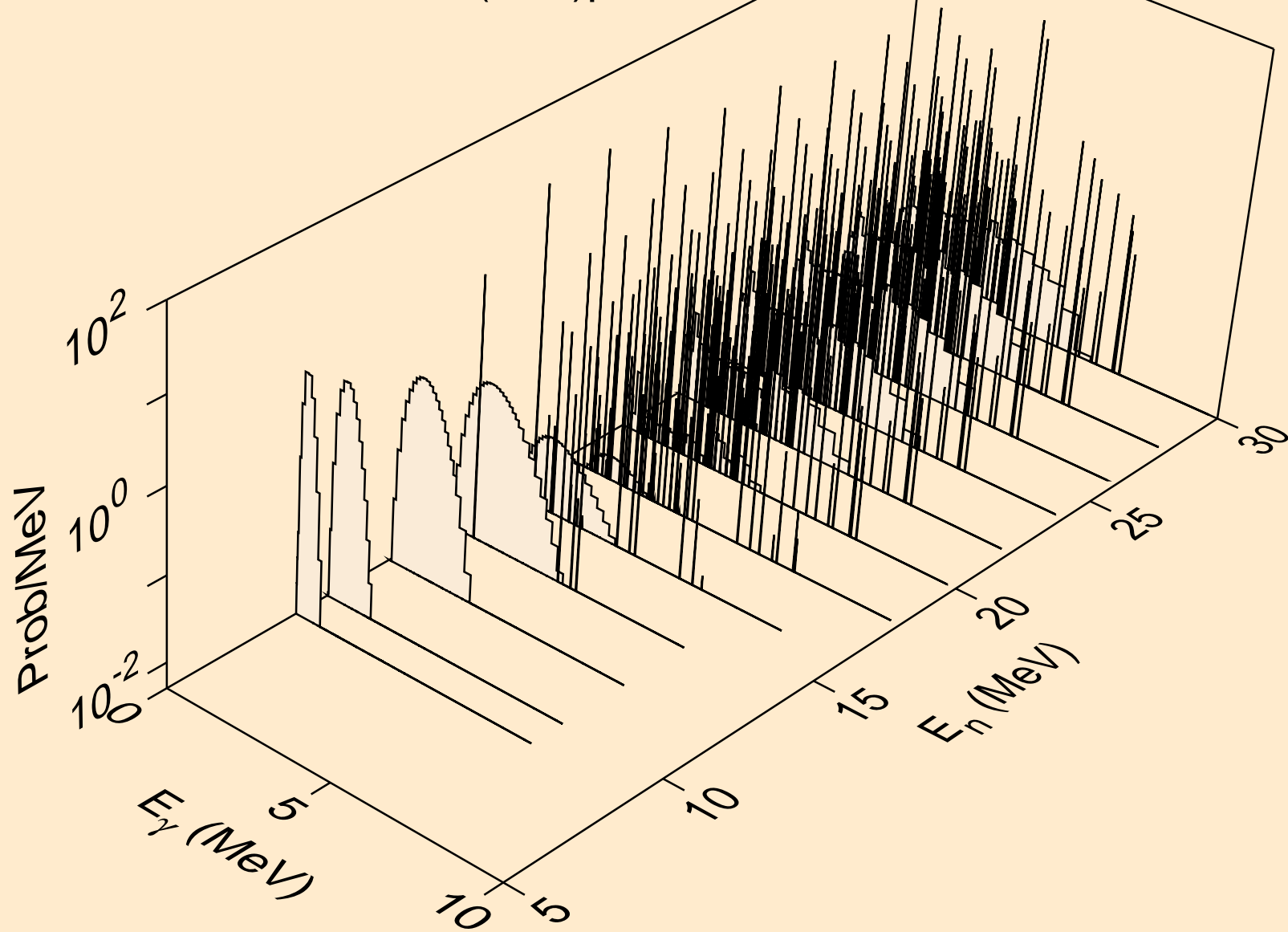

K038 ALPHA ACER TENDL-2024 LIBRARY; T=0.K  
Photon emission for (n,n\*)2a

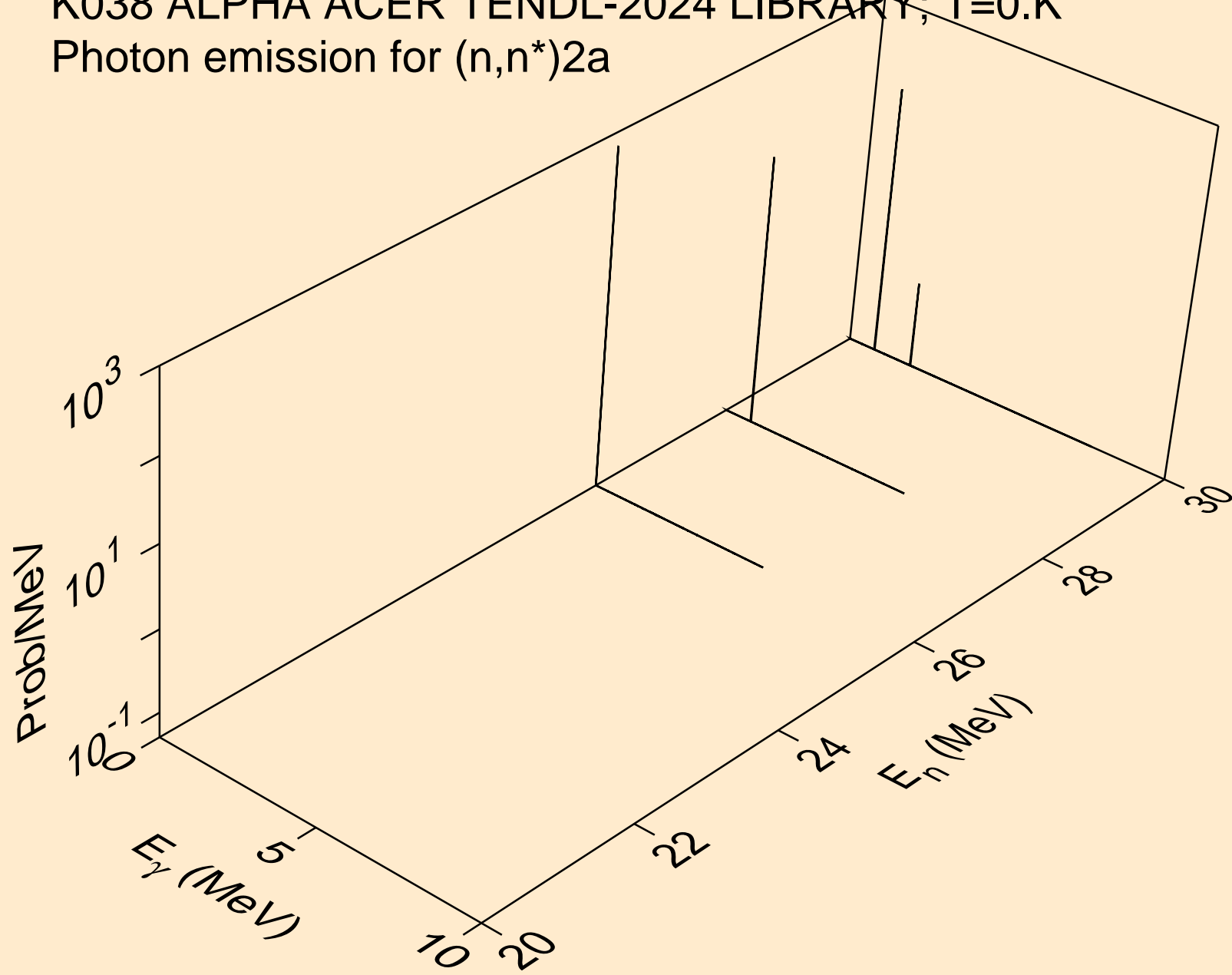

K038 ALPHA ACER TENDL-2024 LIBRARY; T=0.K  
Photon emission for (n,n\*)d

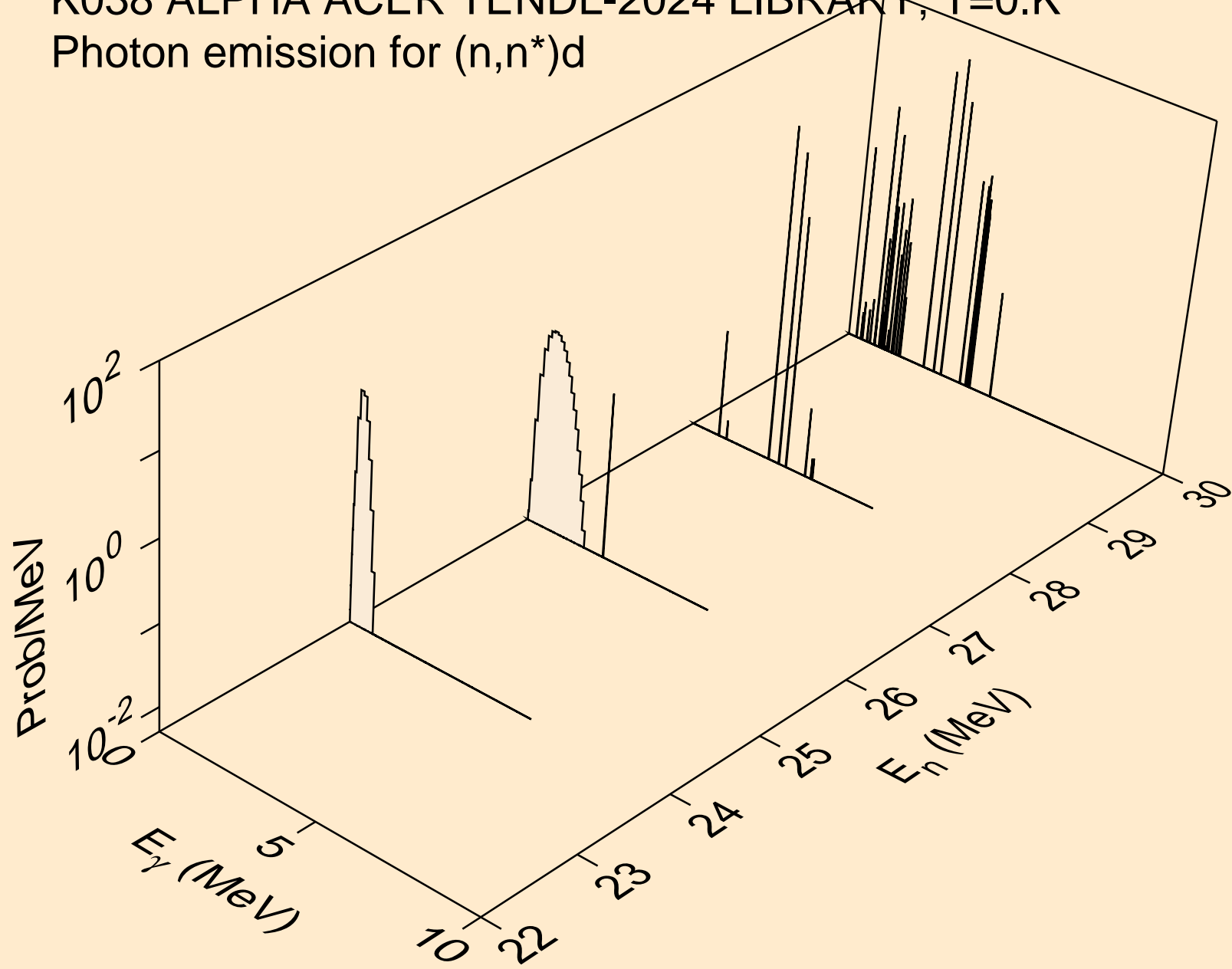

K038 ALPHA ACER TENDL-2024 LIBRARY; T=0.K  
Photon emission for (n,n\*)he3

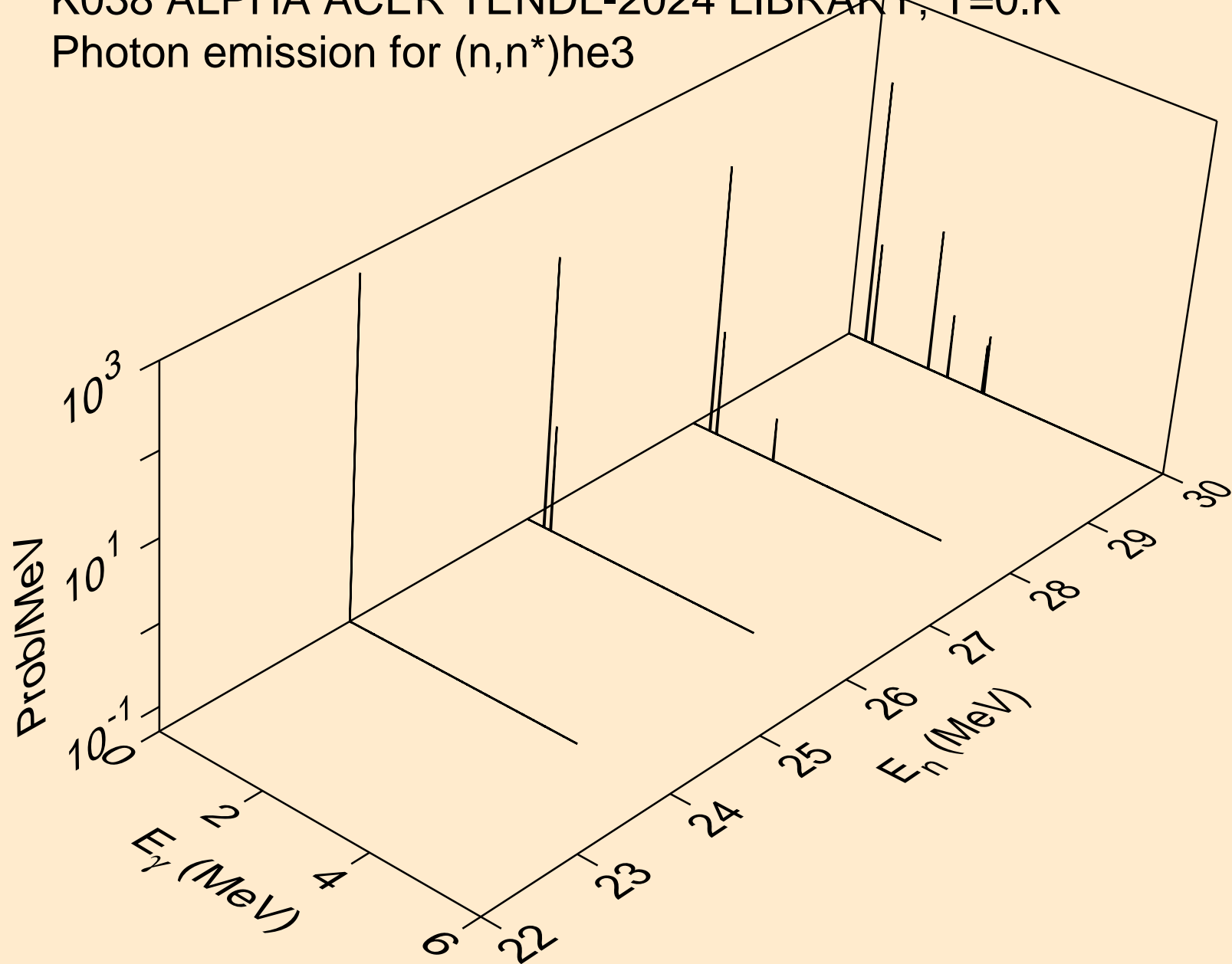

K038 ALPHA ACER TENDL-2024 LIBRARY; T=0.K  
Photon emission for (n,2np)

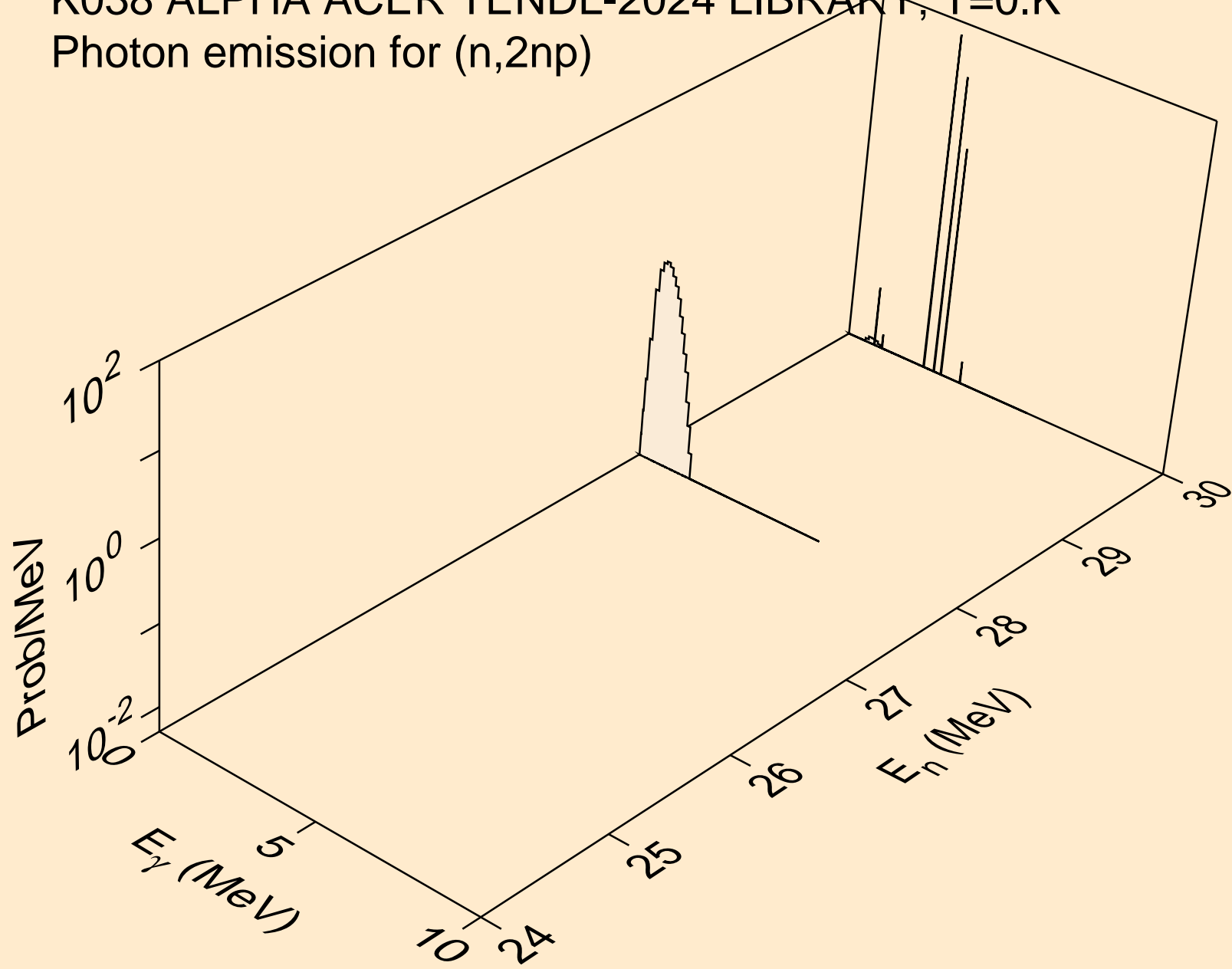

K038 ALPHA ACER TENDL-2024 LIBRARY; T=0.K  
Photon emission for (n,n2p)

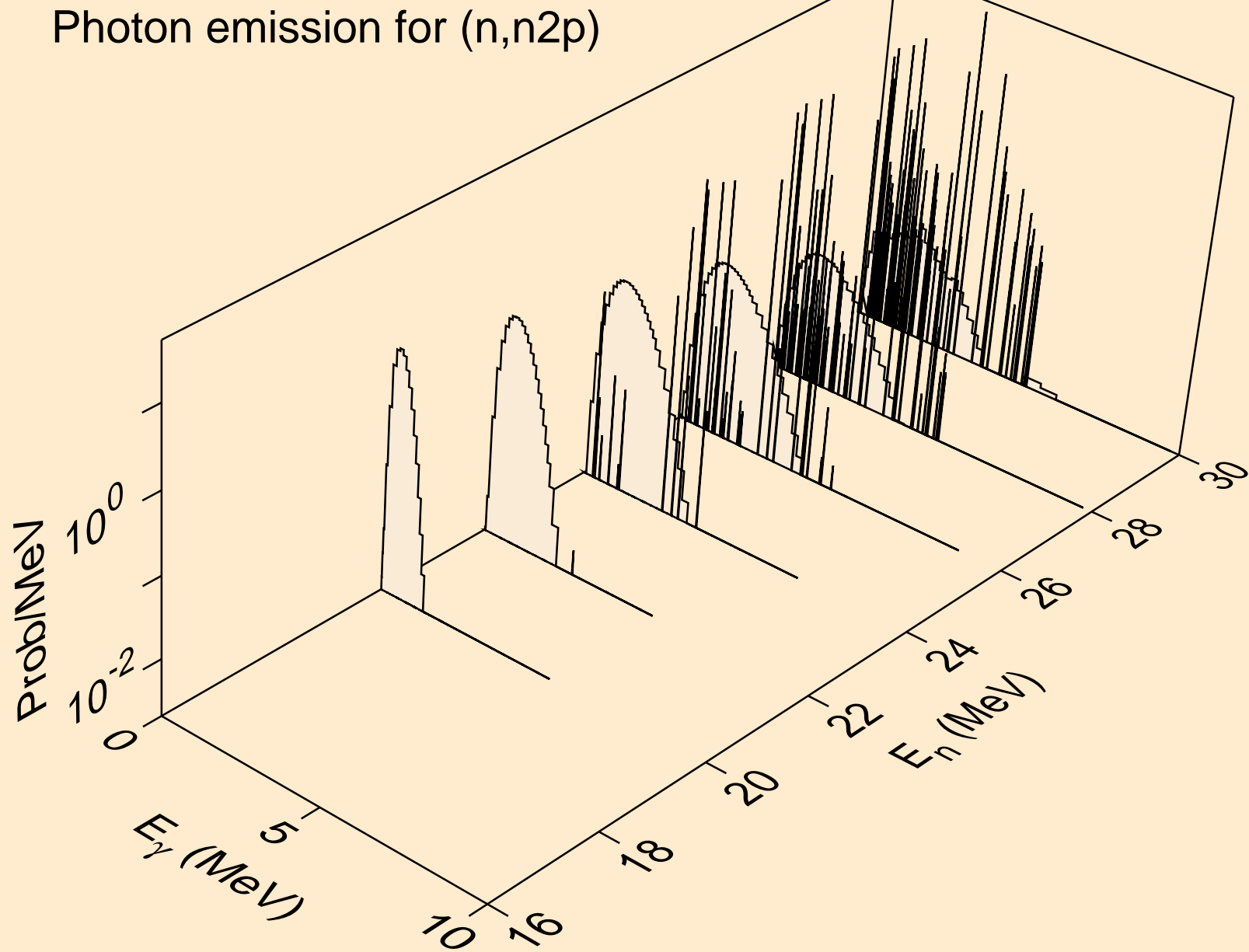

K038 ALPHA ACER TENDL-2024 LIBRARY; T=0.K  
Photon emission for (n,npa)

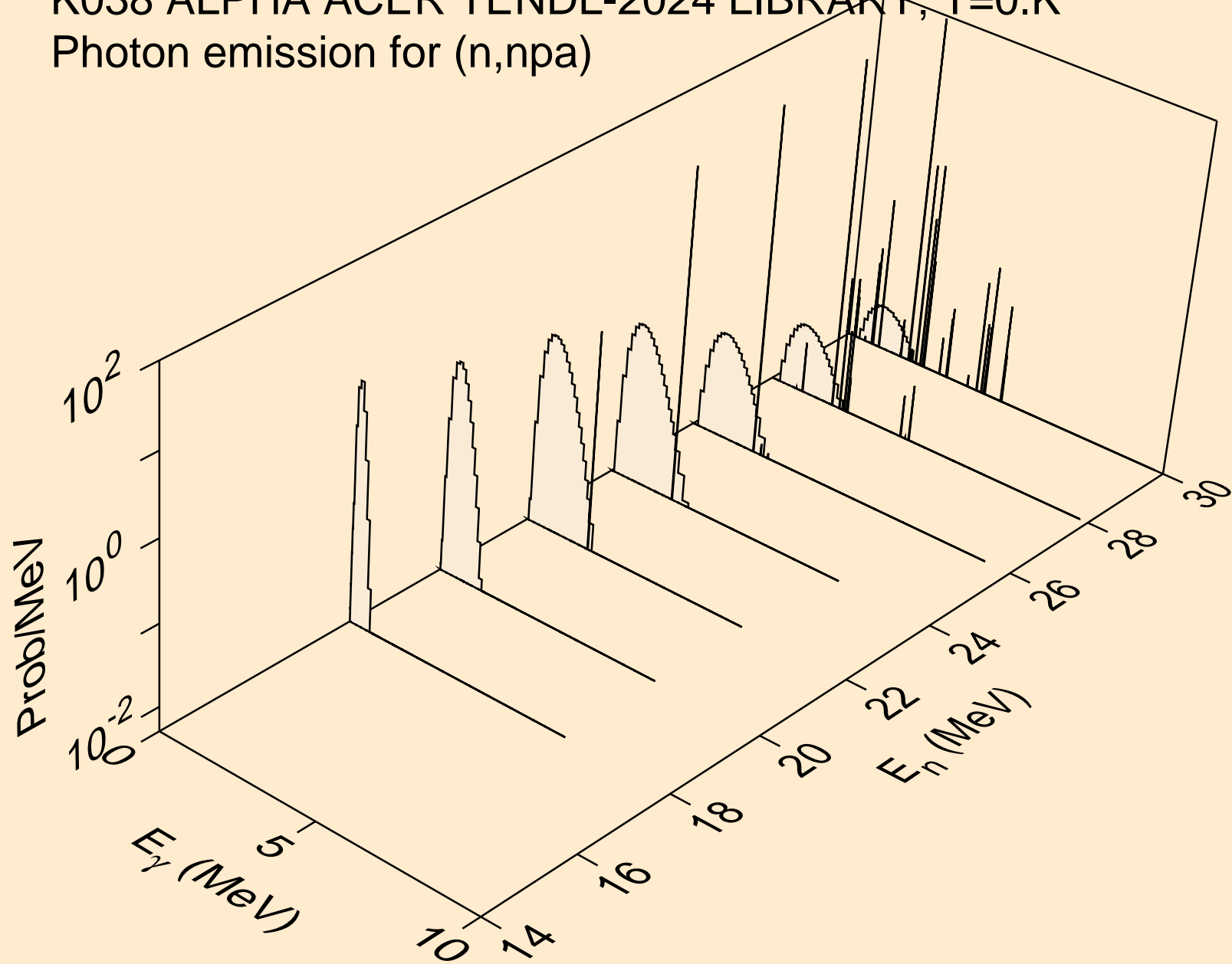

K038 ALPHA ACER TENDL-2024 LIBRARY; T=0.K  
Photon emission for (n,gma)

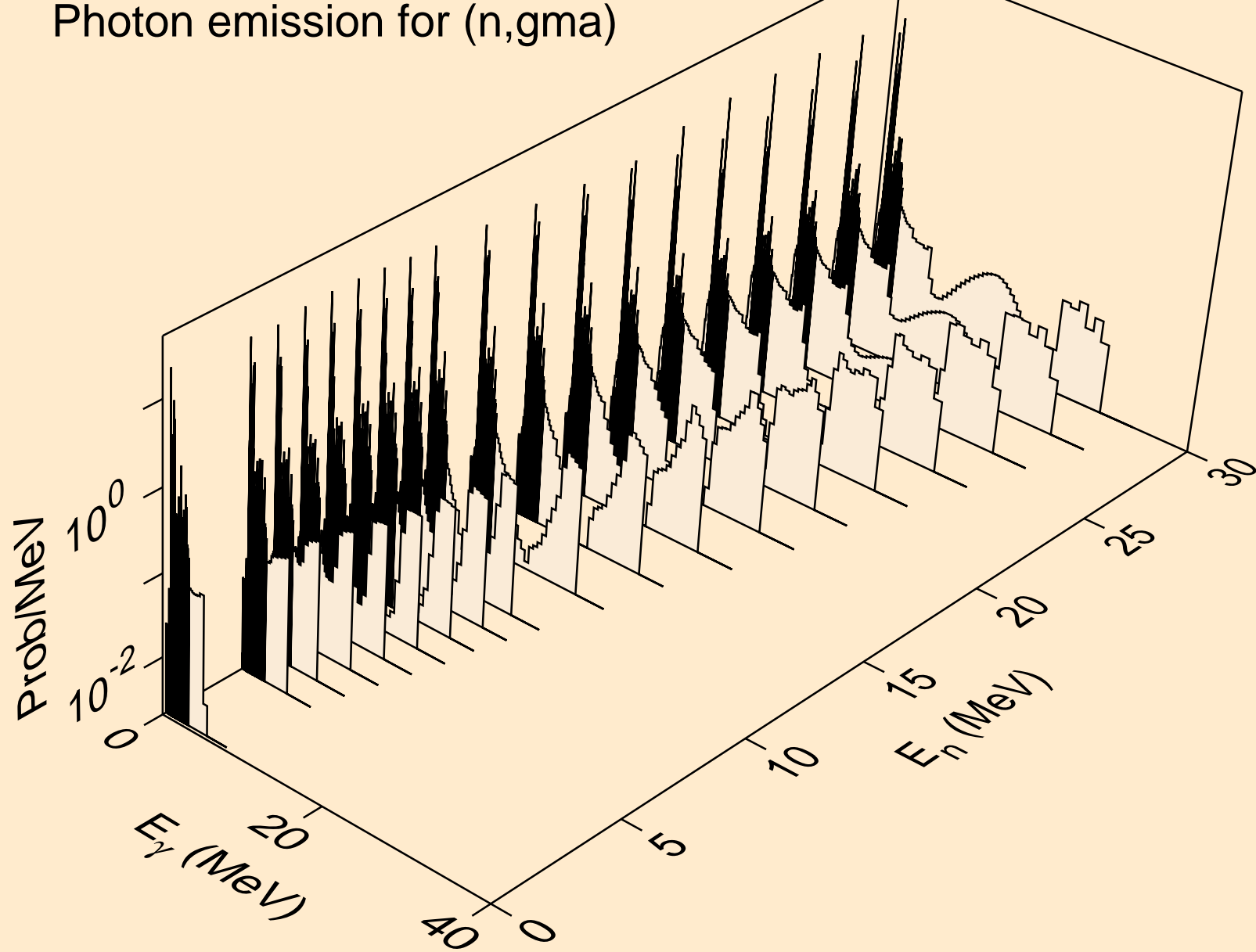

K038 ALPHA ACER TENDL-2024 LIBRARY; T=0.K  
Photon emission for (n,p)

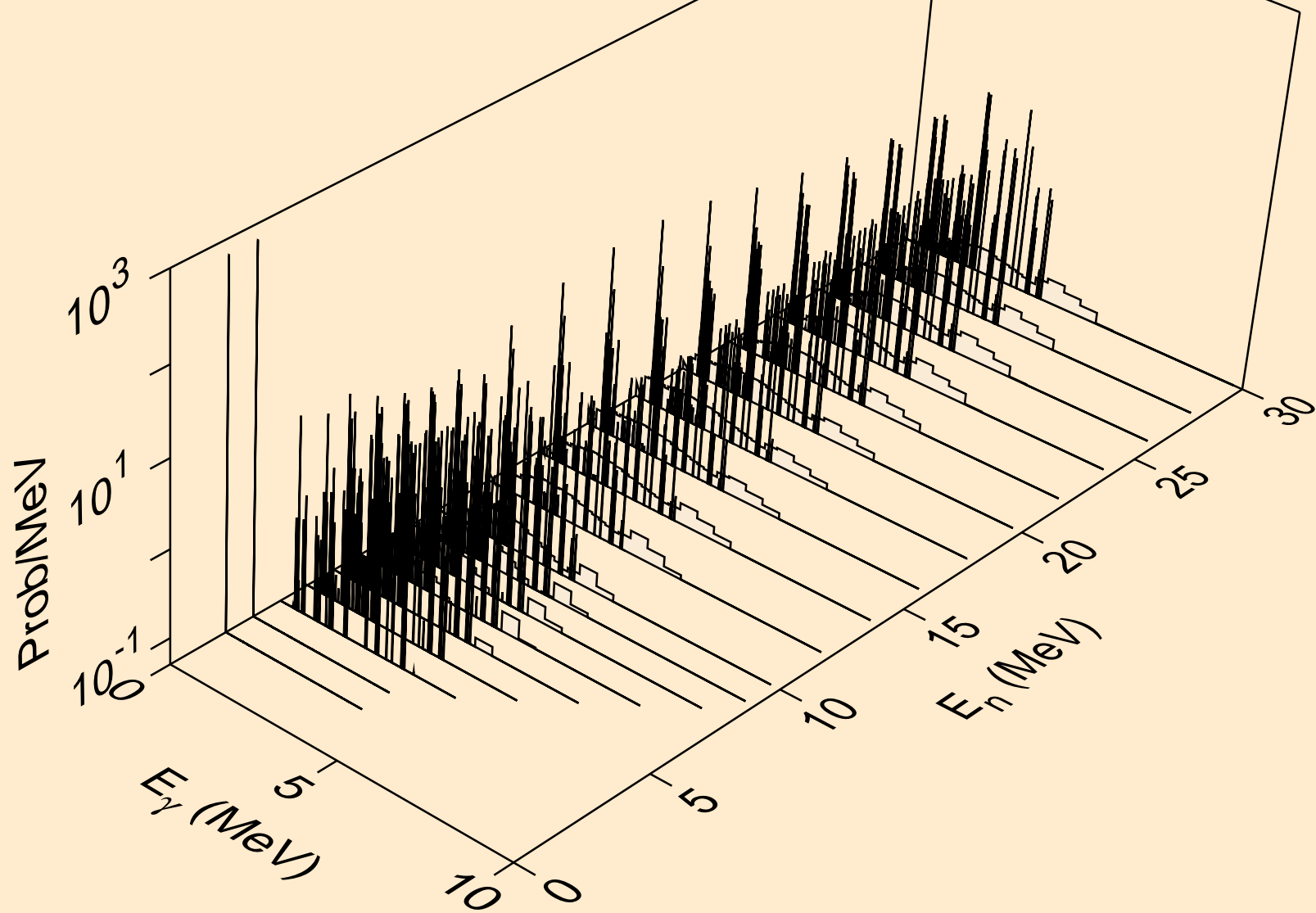

K038 ALPHA ACER TENDL-2024 LIBRARY; T=0.K  
Photon emission for (n,d)

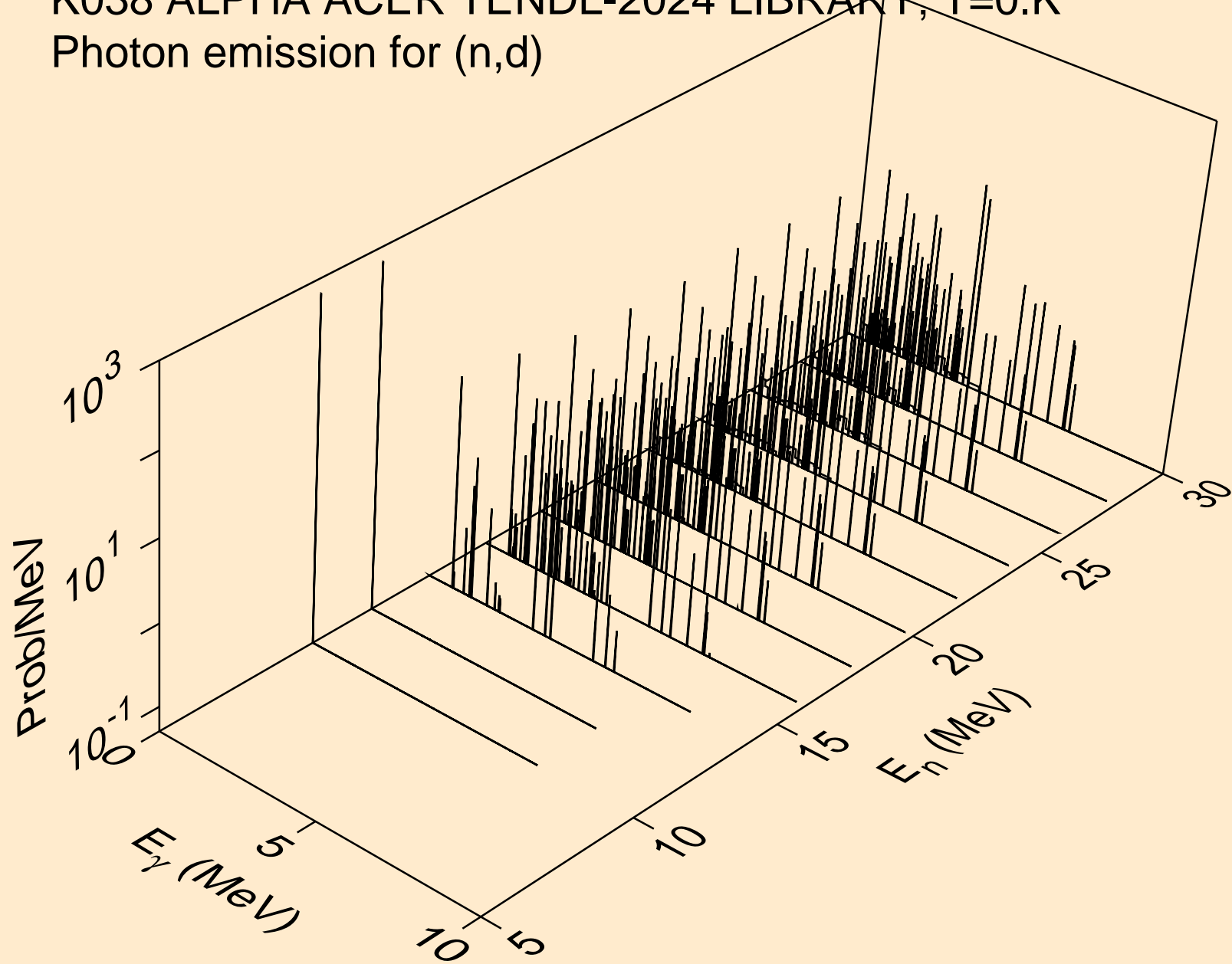

K038 ALPHA ACER TENDL-2024 LIBRARY; T=0.K  
Photon emission for (n,t)

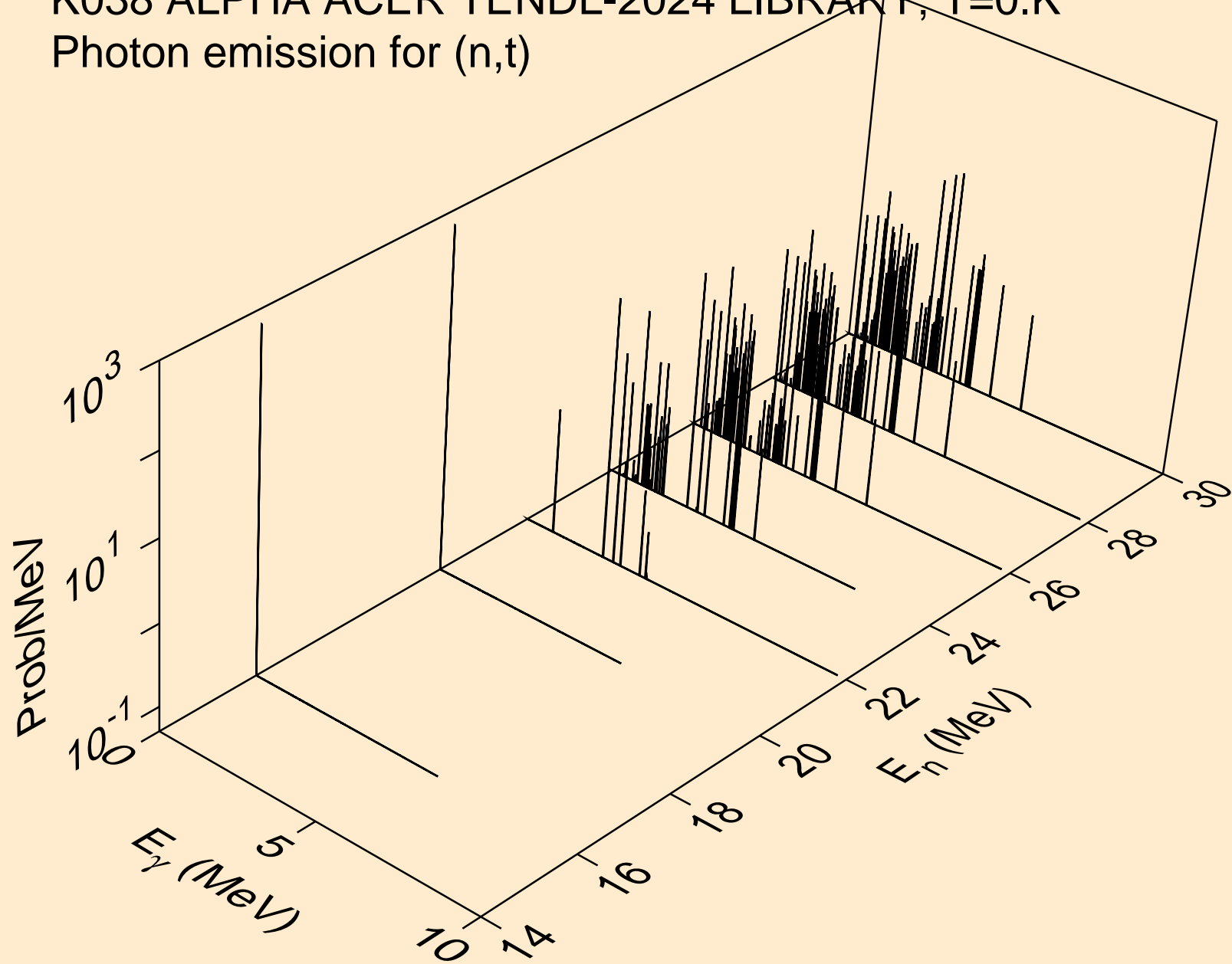

K038 ALPHA ACER TENDL-2024 LIBRARY; T=0.K  
Photon emission for (n,he3)

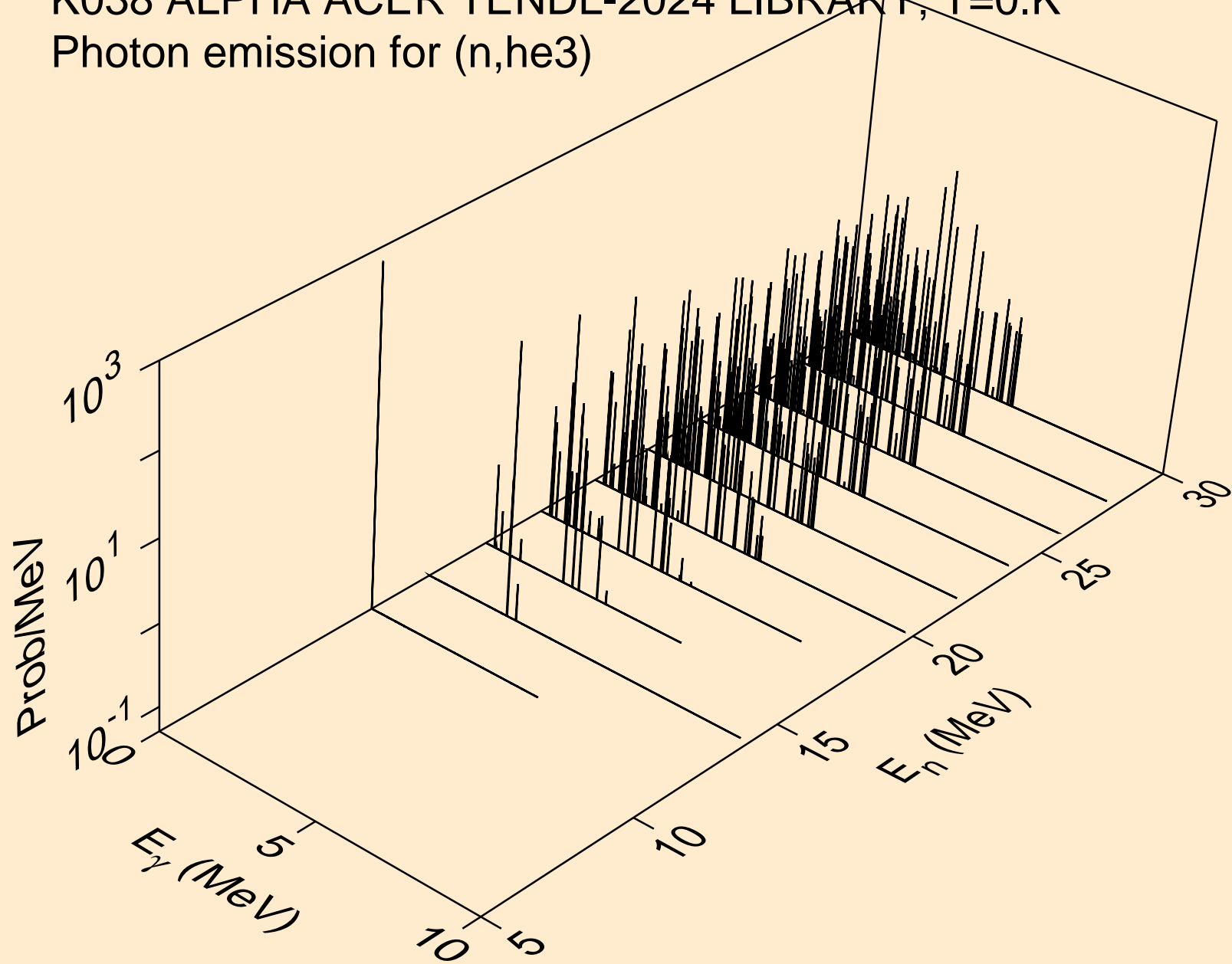

K038 ALPHA ACER TENDL-2024 LIBRARY; T=0.K  
Photon emission for inelastic

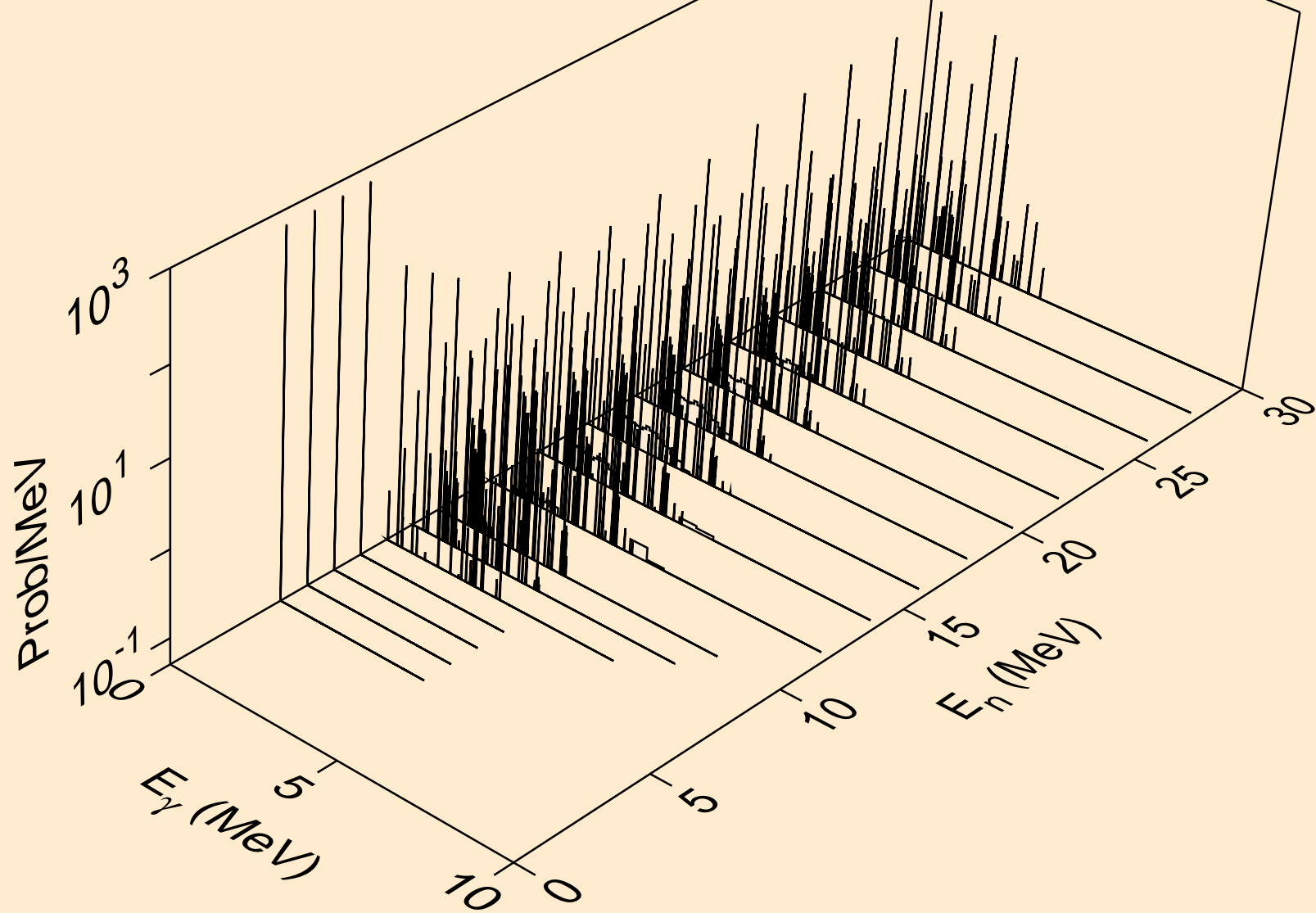

K038 ALPHA ACER TENDL-2024 LIBRARY; T=0.K  
Photon emission for (n,2a)

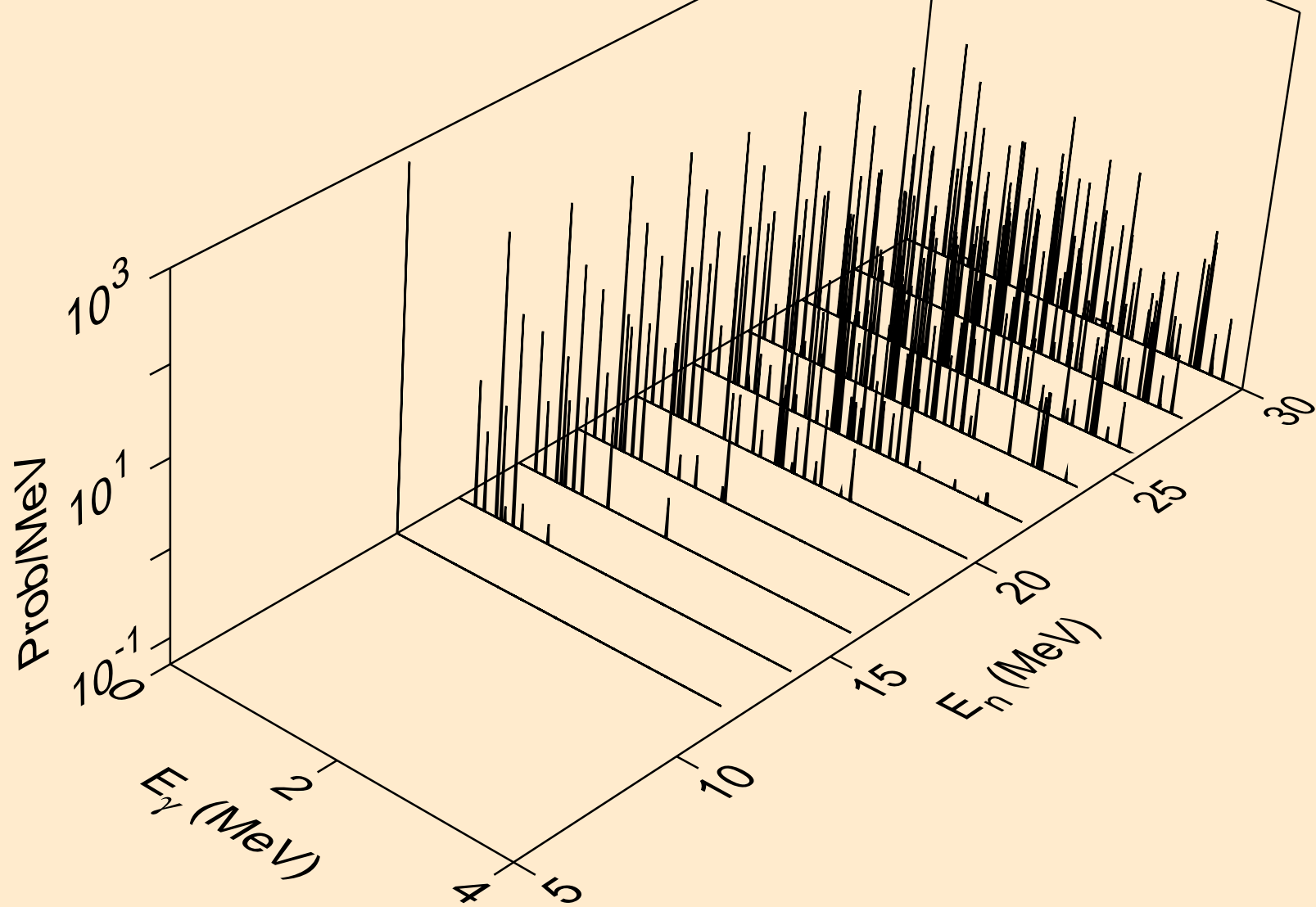

K038 ALPHA ACER TENDL-2024 LIBRARY; T=0.K  
Photon emission for (n,3a)

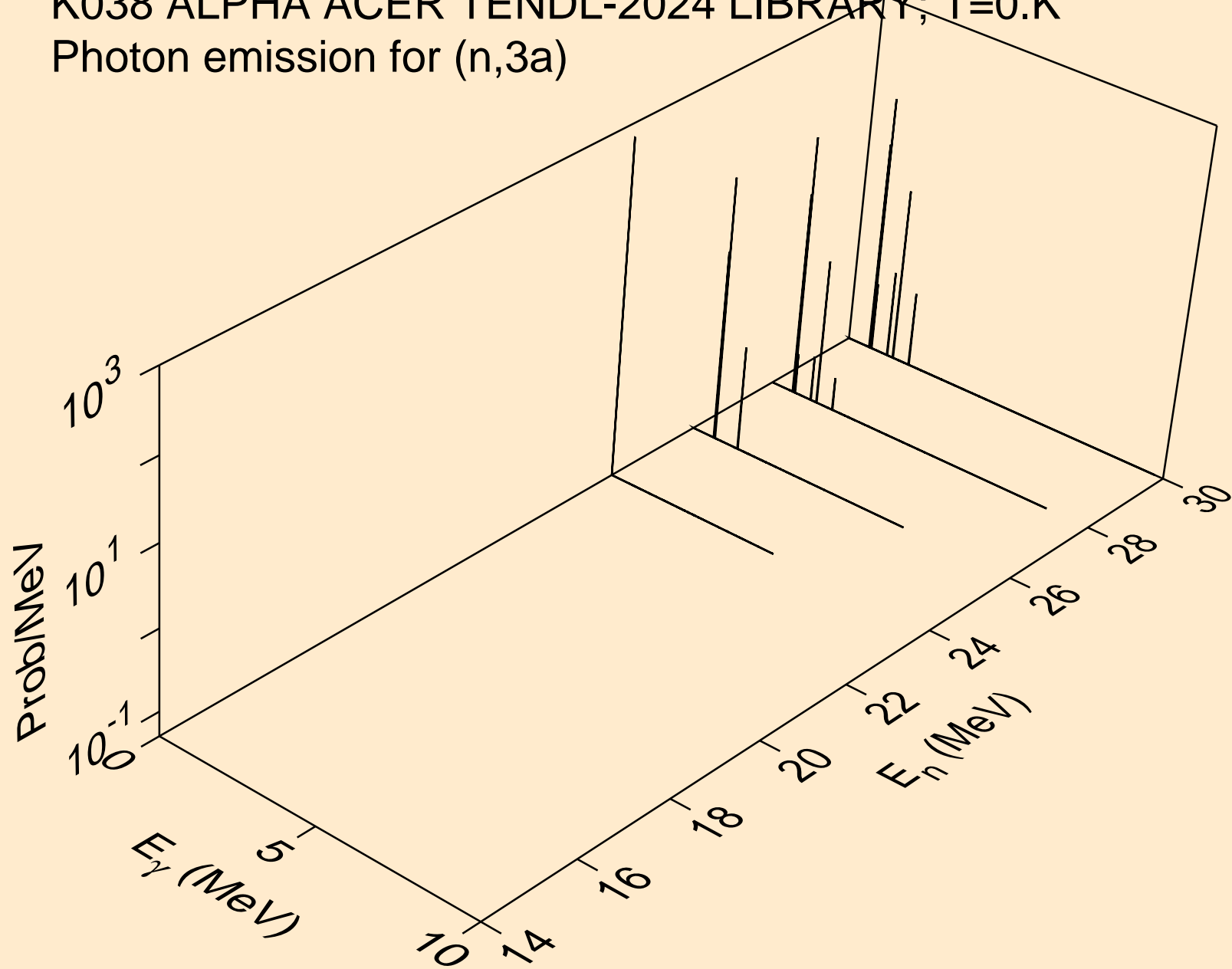

K038 ALPHA ACER TENDL-2024 LIBRARY; T=0.K  
Photon emission for (n,2p)

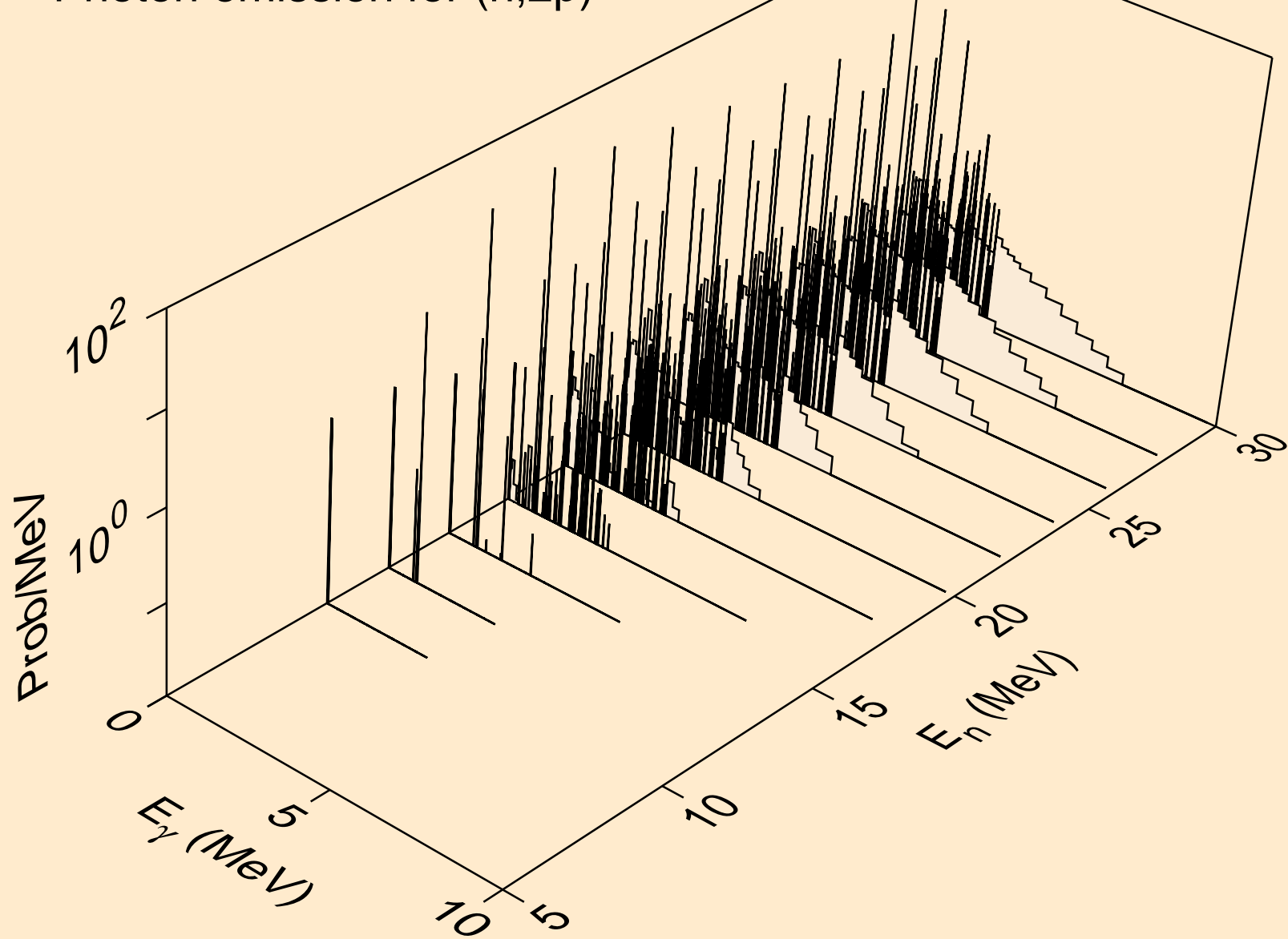

K038 ALPHA ACER TENDL-2024 LIBRARY; T=0.K  
Photon emission for (n,pa)

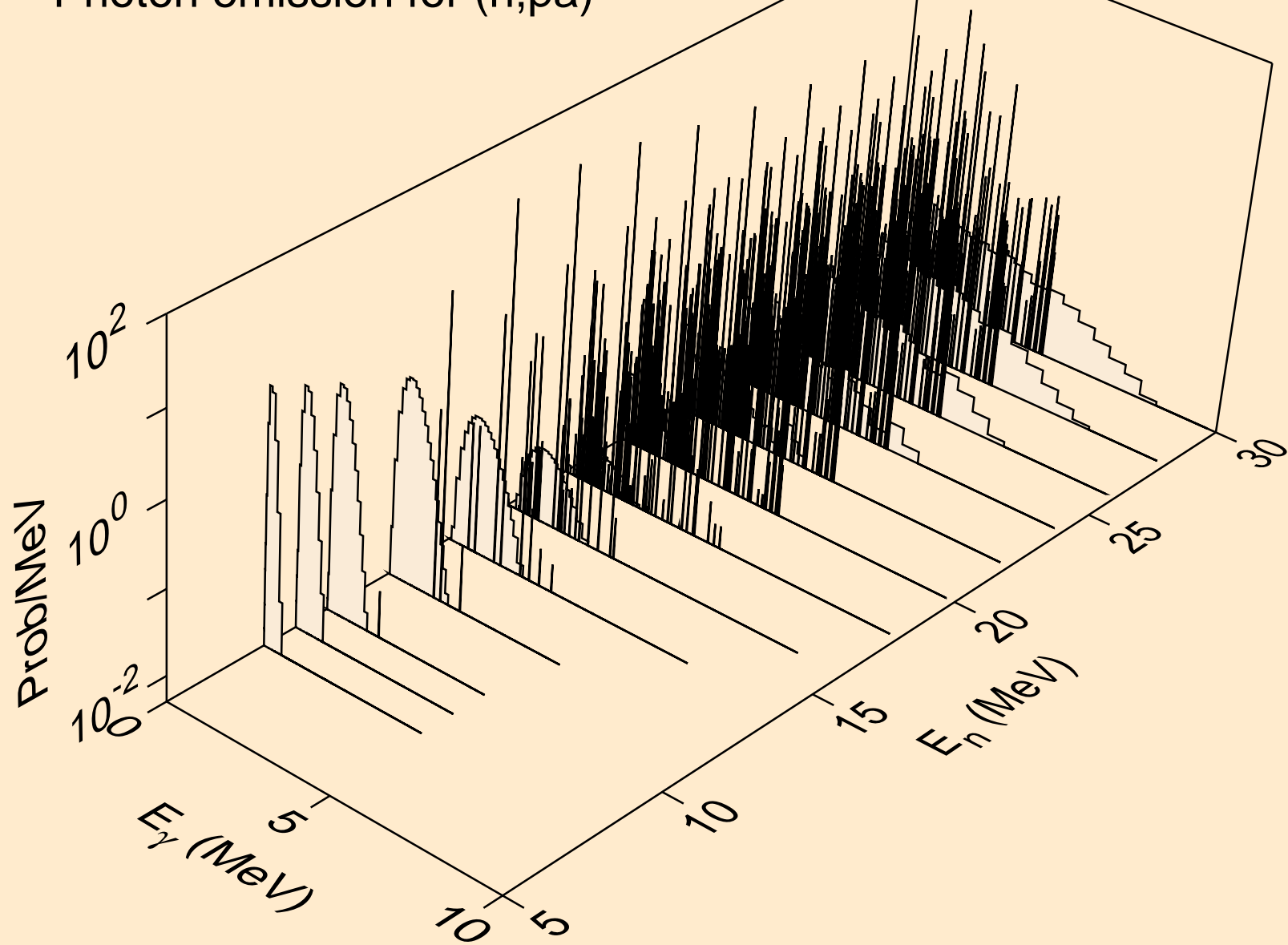

K038 ALPHA ACER TENDL-2024 LIBRARY; T=0.K  
Photon emission for (n,pd)

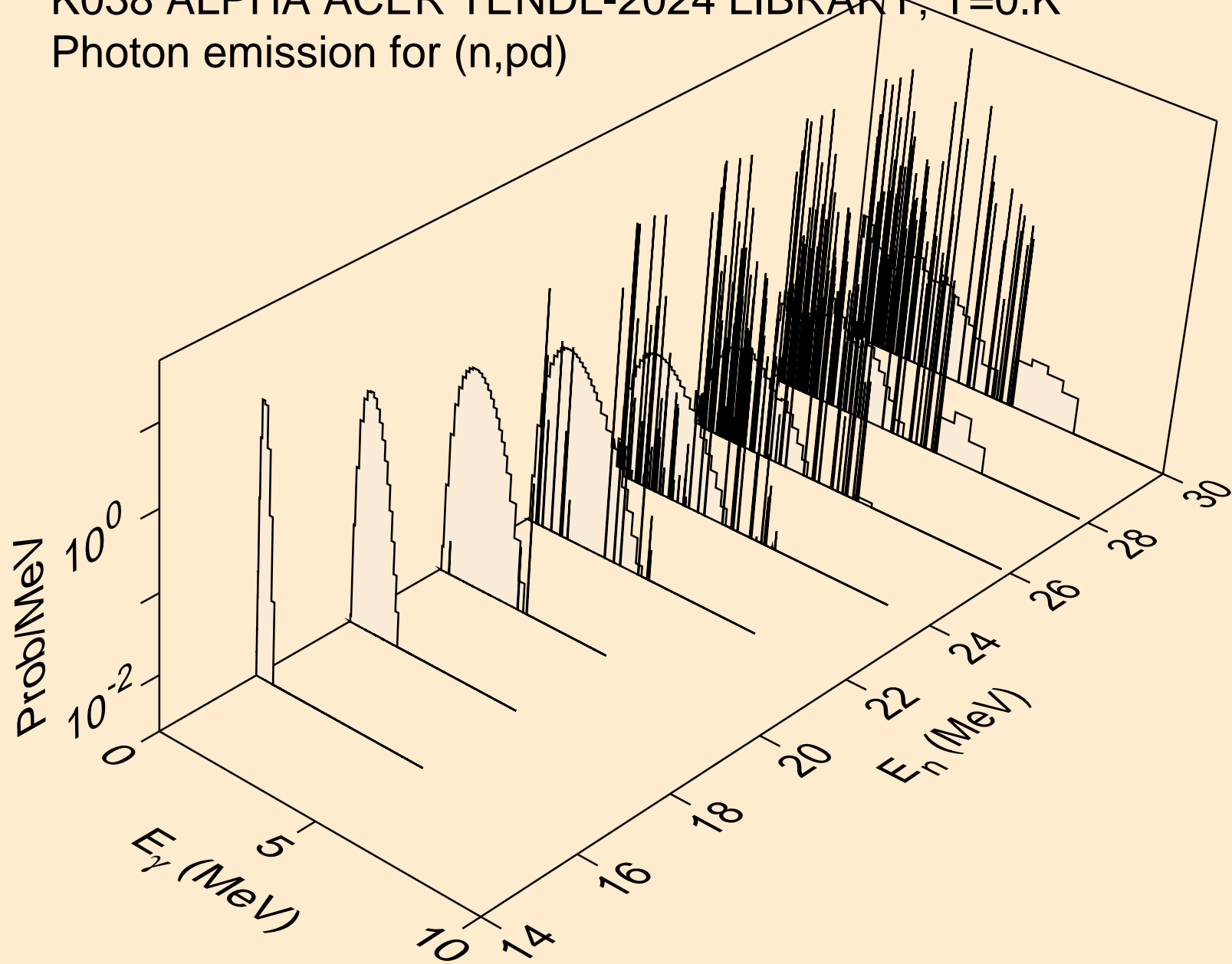

K038 ALPHA ACER TENDL-2024 LIBRARY; T=0.K  
Photon emission for (n,pt)

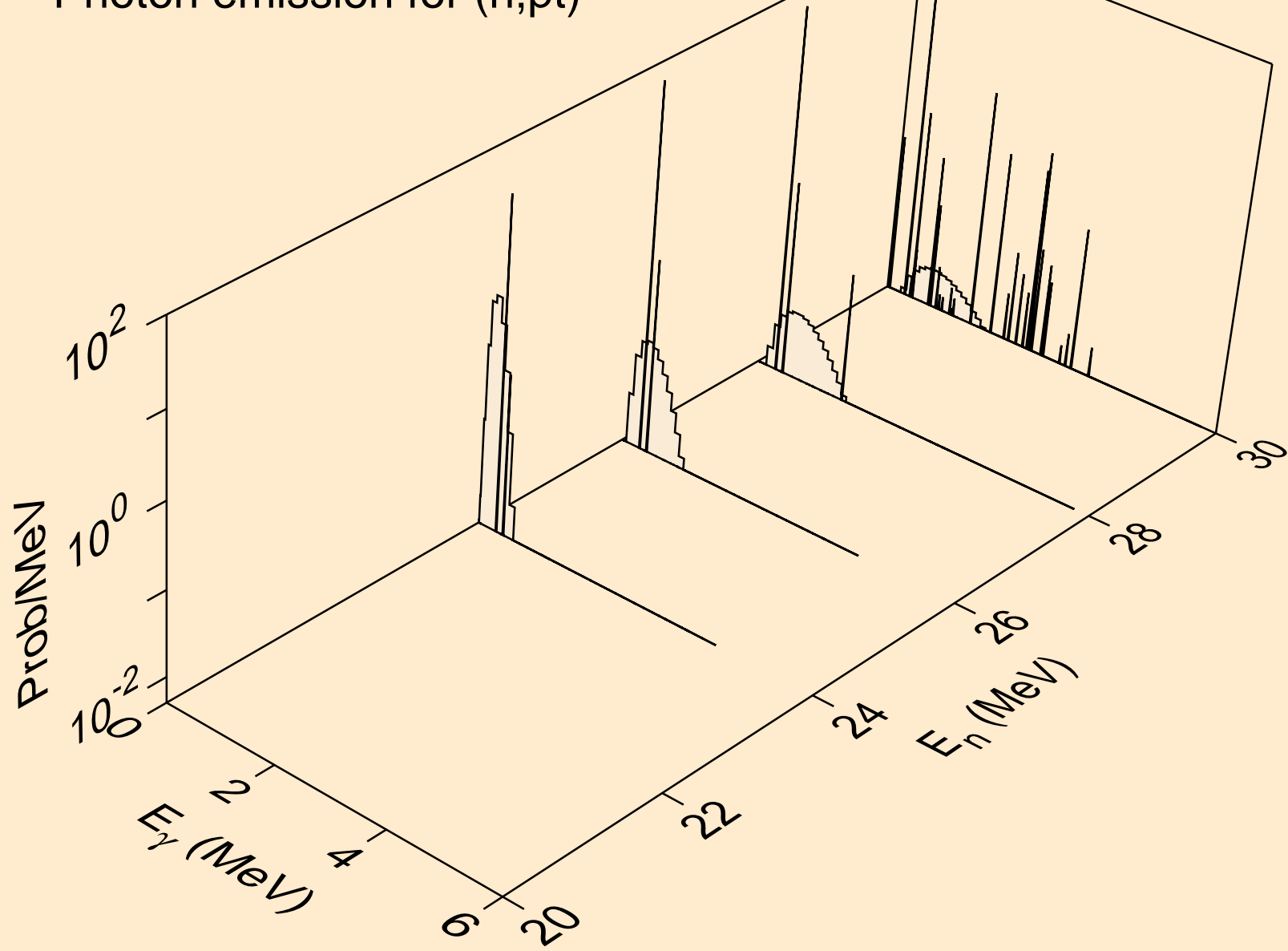

K038 ALPHA ACER TENDL-2024 LIBRARY; T=0.K  
Photon emission for (n,da)

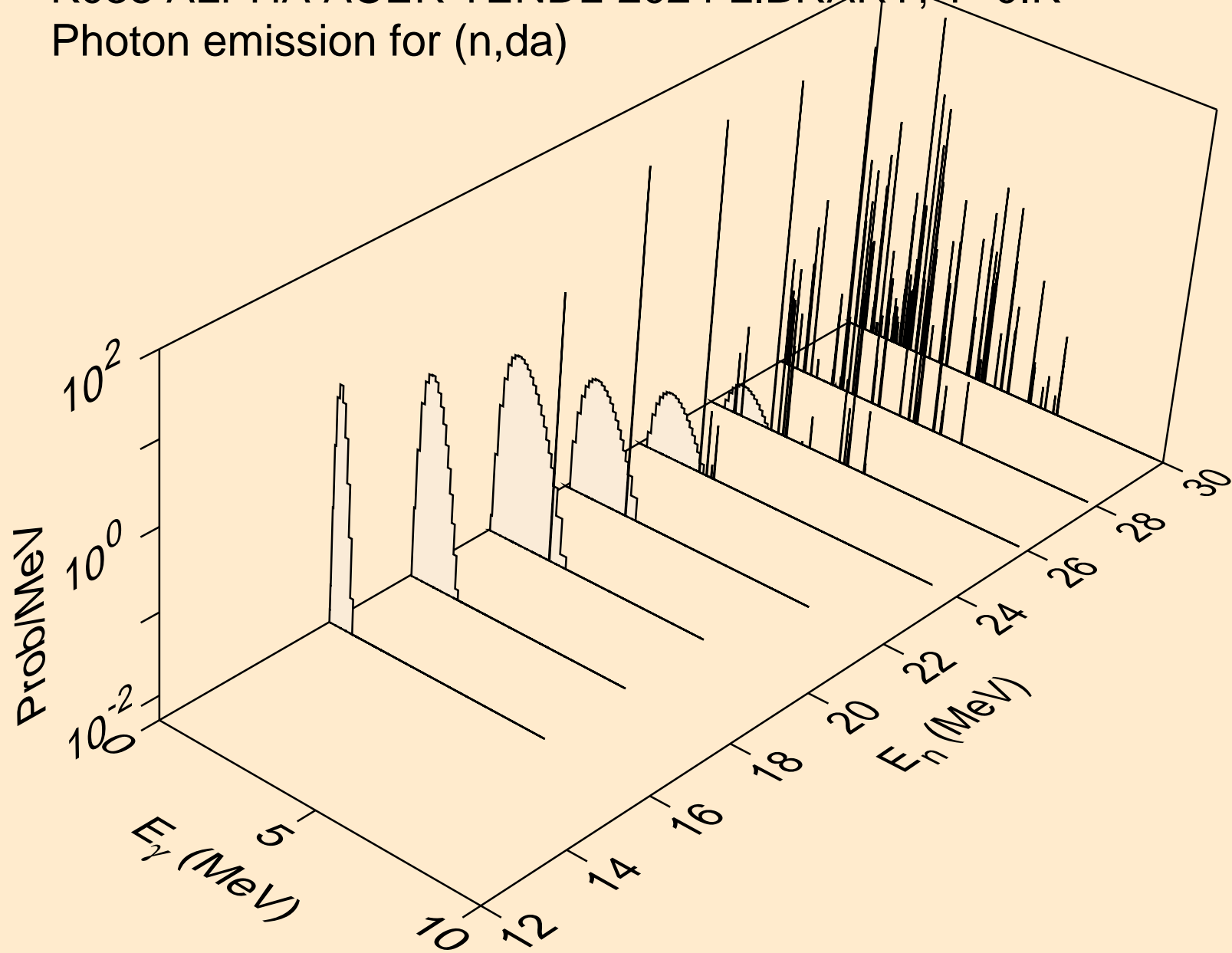

K038 ALPHA ACER TENDL-2024 LIBRARY; T=0.K  
Particle heating contributions

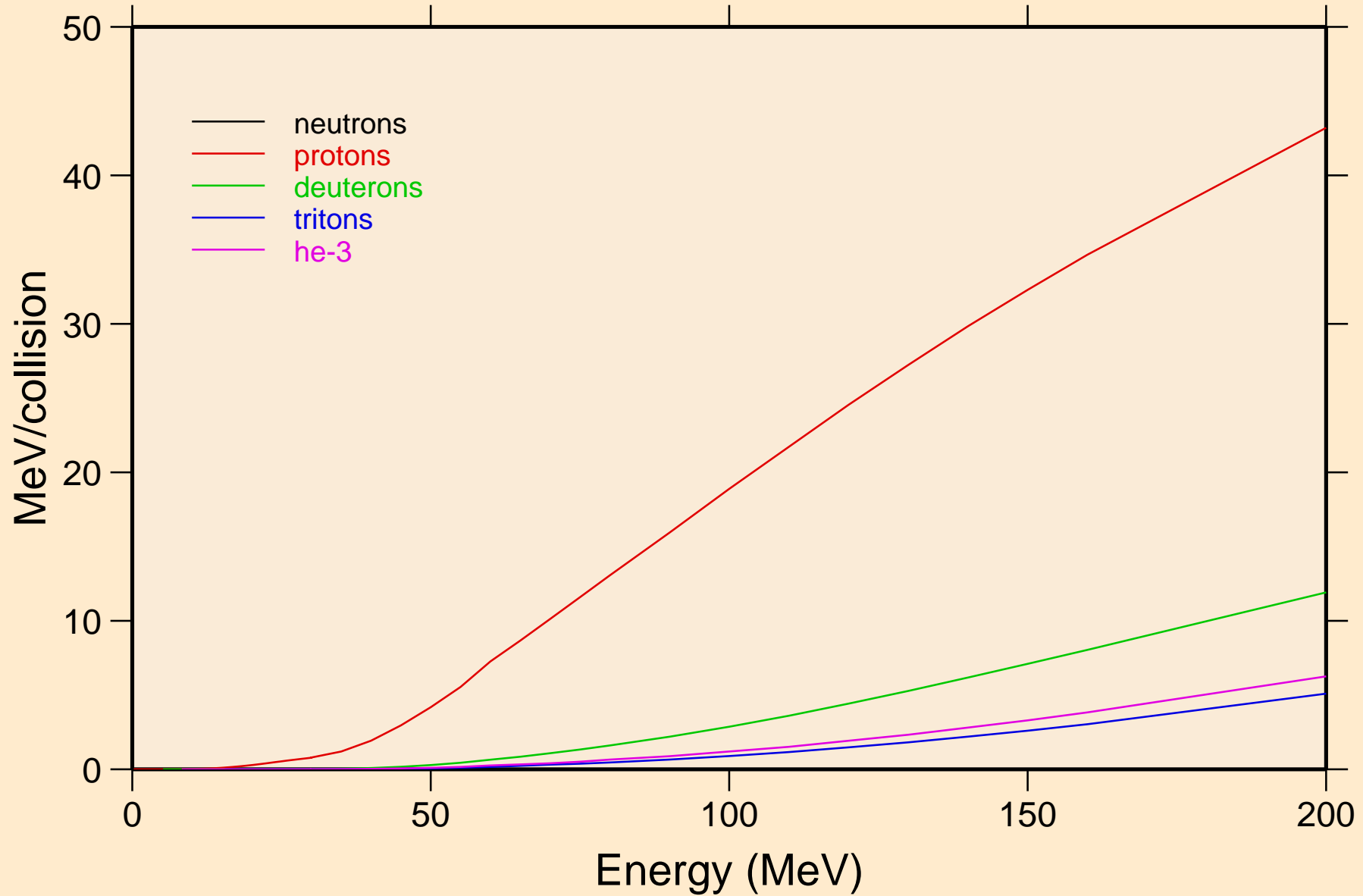

K038 ALPHA ACER TENDL-2024 LIBRARY; T=0.K  
Recoil Heating

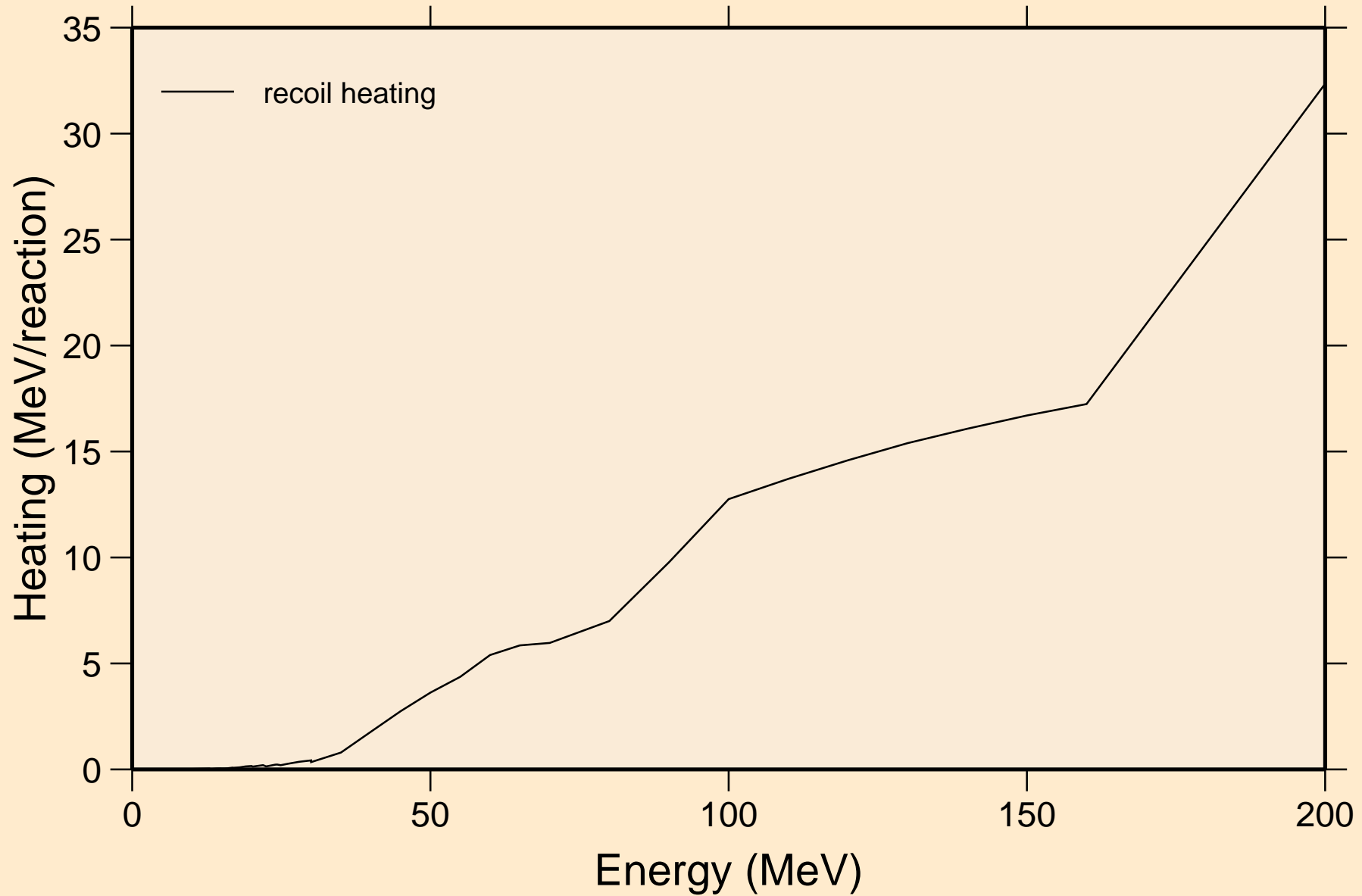

K038 ALPHA ACER TENDL-2024 LIBRARY; T=0.K  
Particle production cross sections

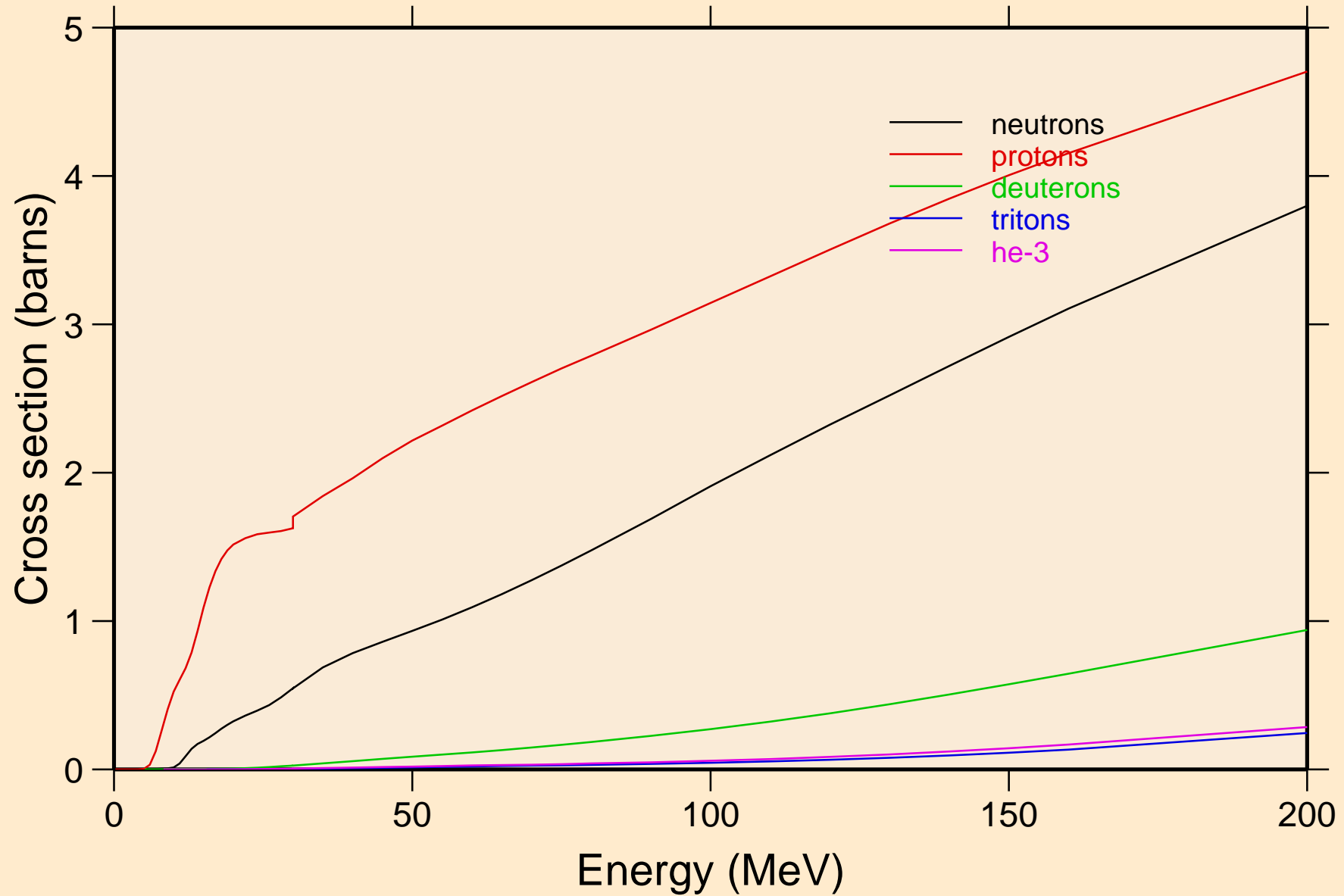

K038 ALPHA ACER TENDL-2024 LIBRARY; T=0.K  
neutrons from (a,n)

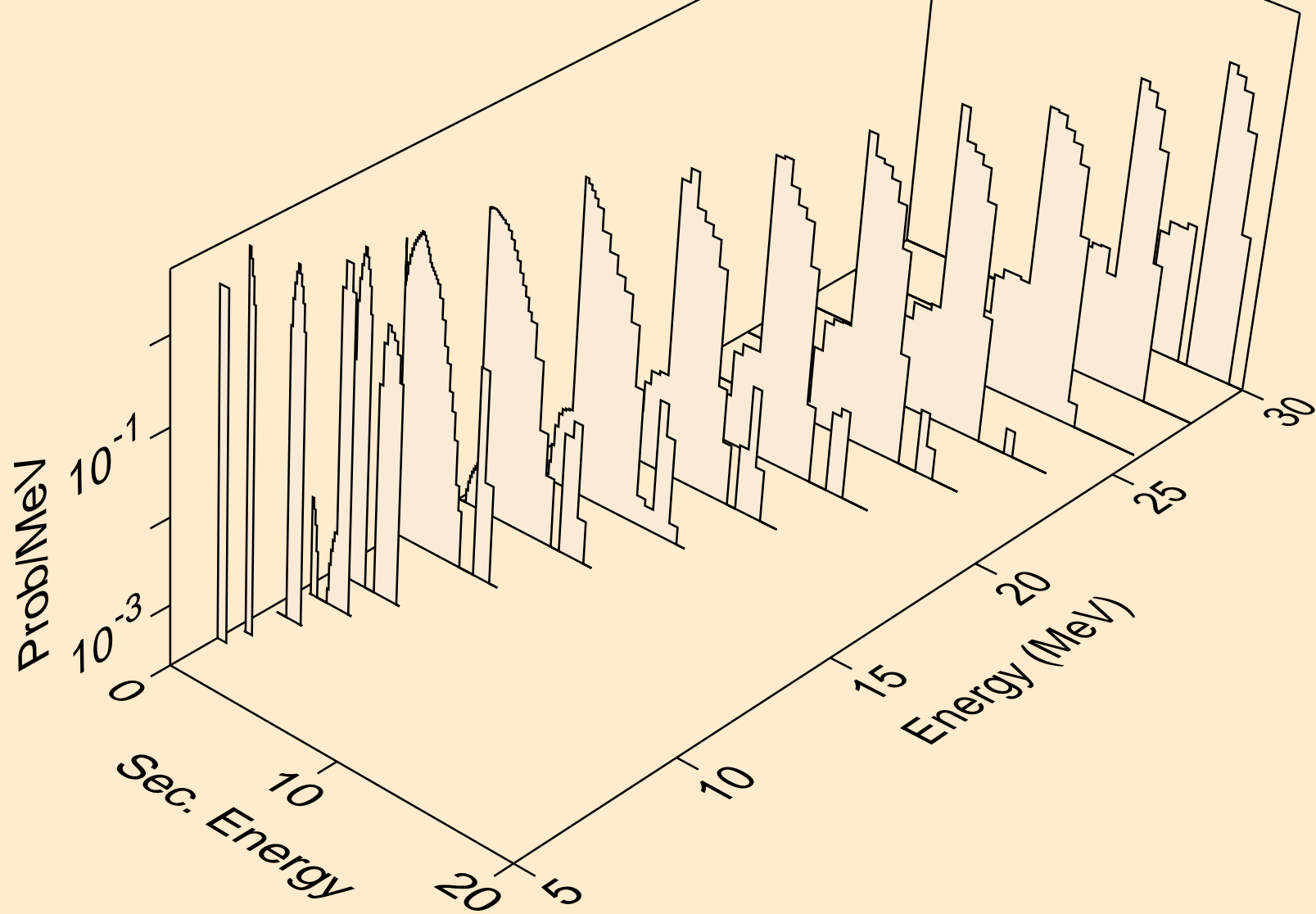

K038 ALPHA ACER TENDL-2024 LIBRARY; T=0.K  
neutrons from (a,x)

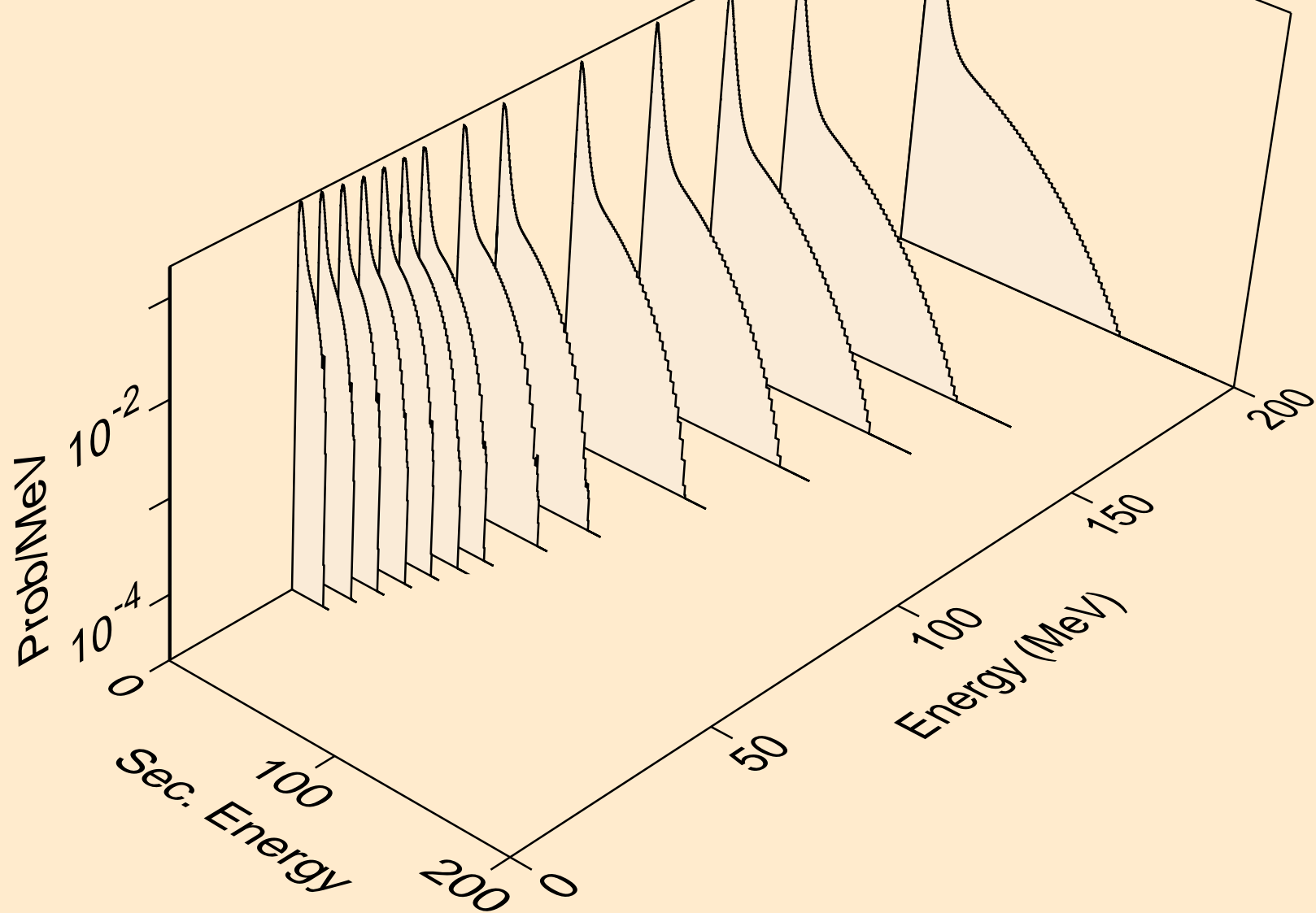

K038 ALPHA ACER TENDL-2024 LIBRARY; T=0.K  
neutrons from (a,2n)

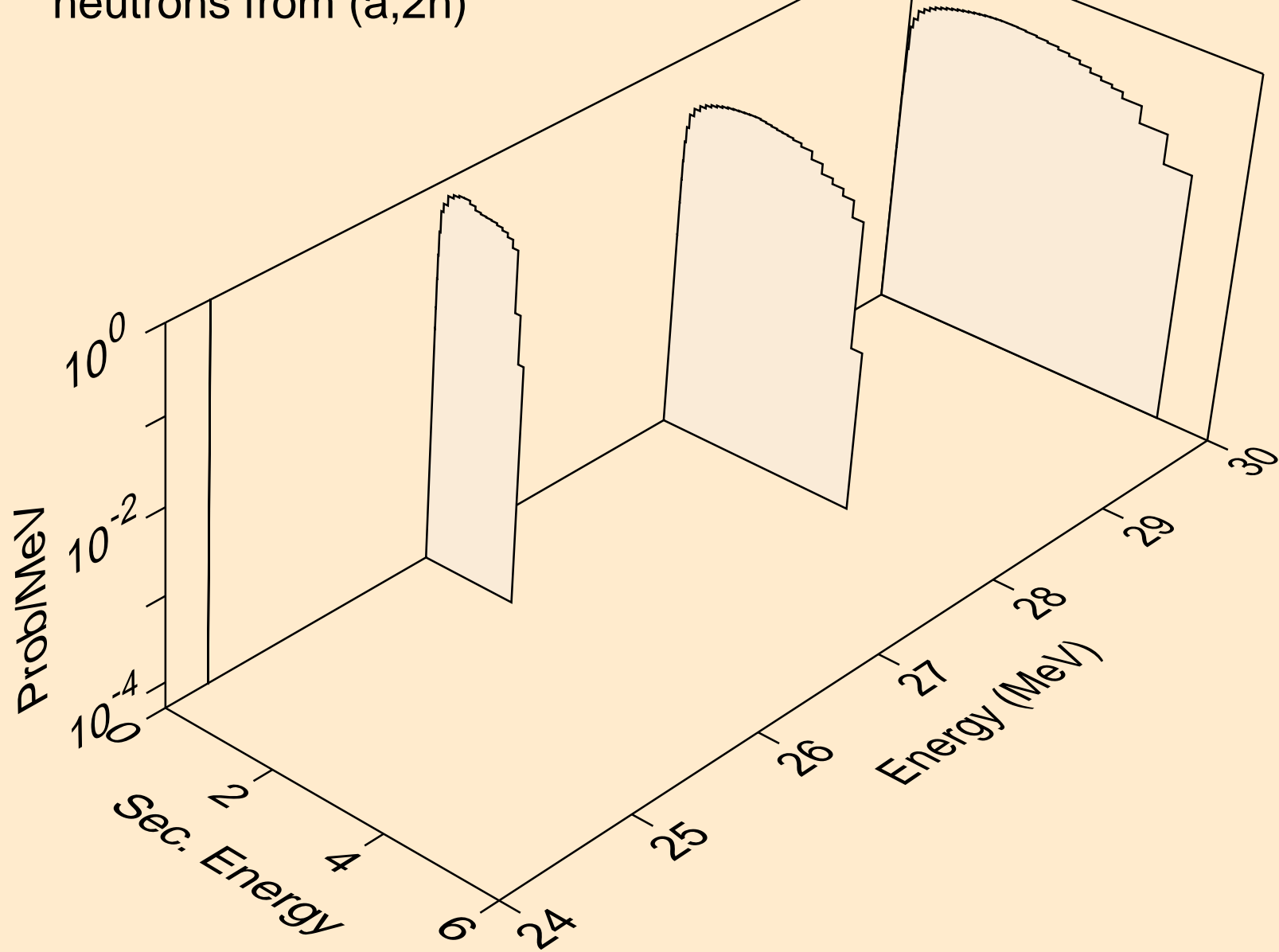

K038 ALPHA ACER TENDL-2024 LIBRARY; T=0.K  
neutrons from (a,n\*)a

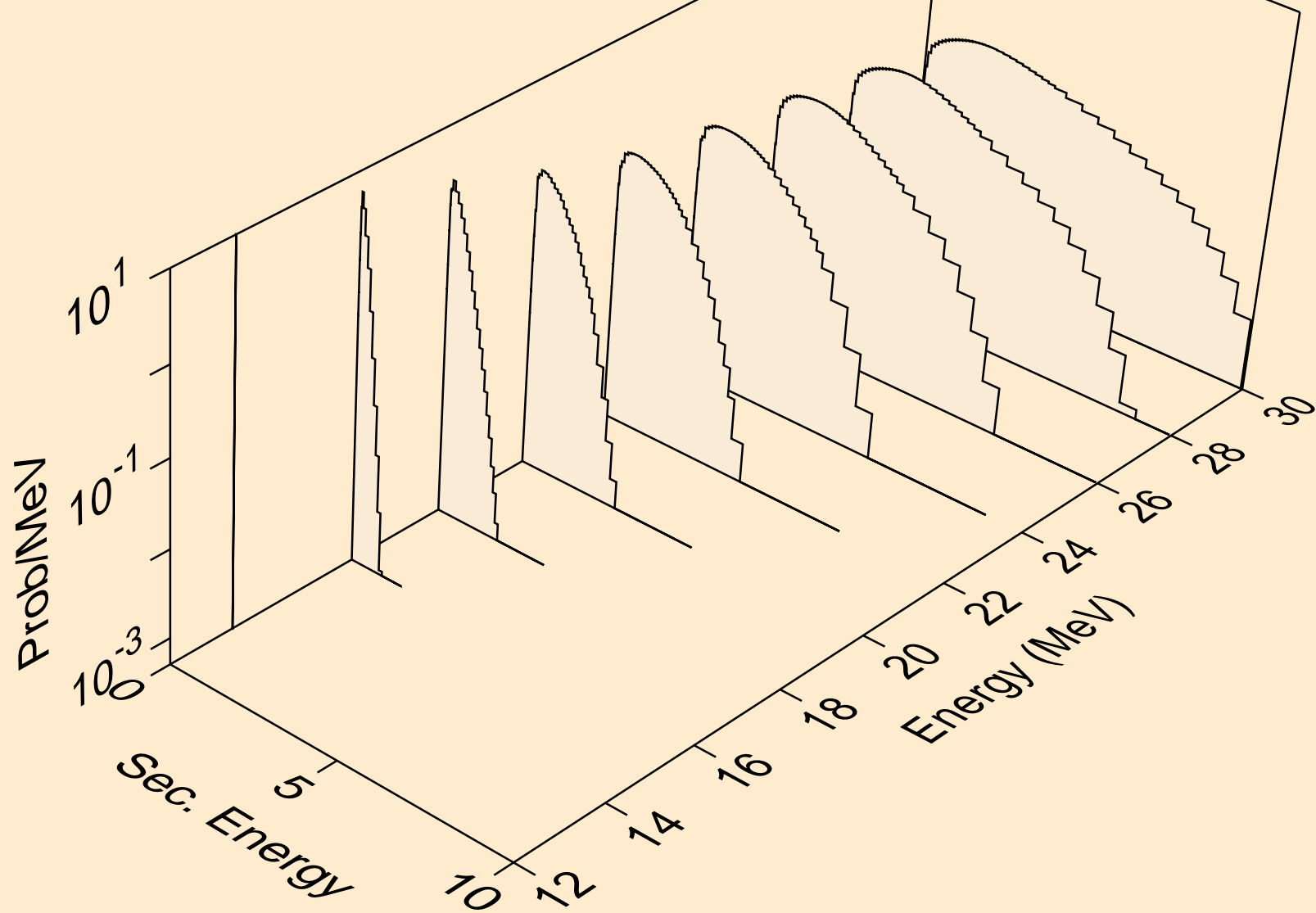

K038 ALPHA ACER TENDL-2024 LIBRARY; T=0.K  
neutrons from (a,n\*)p

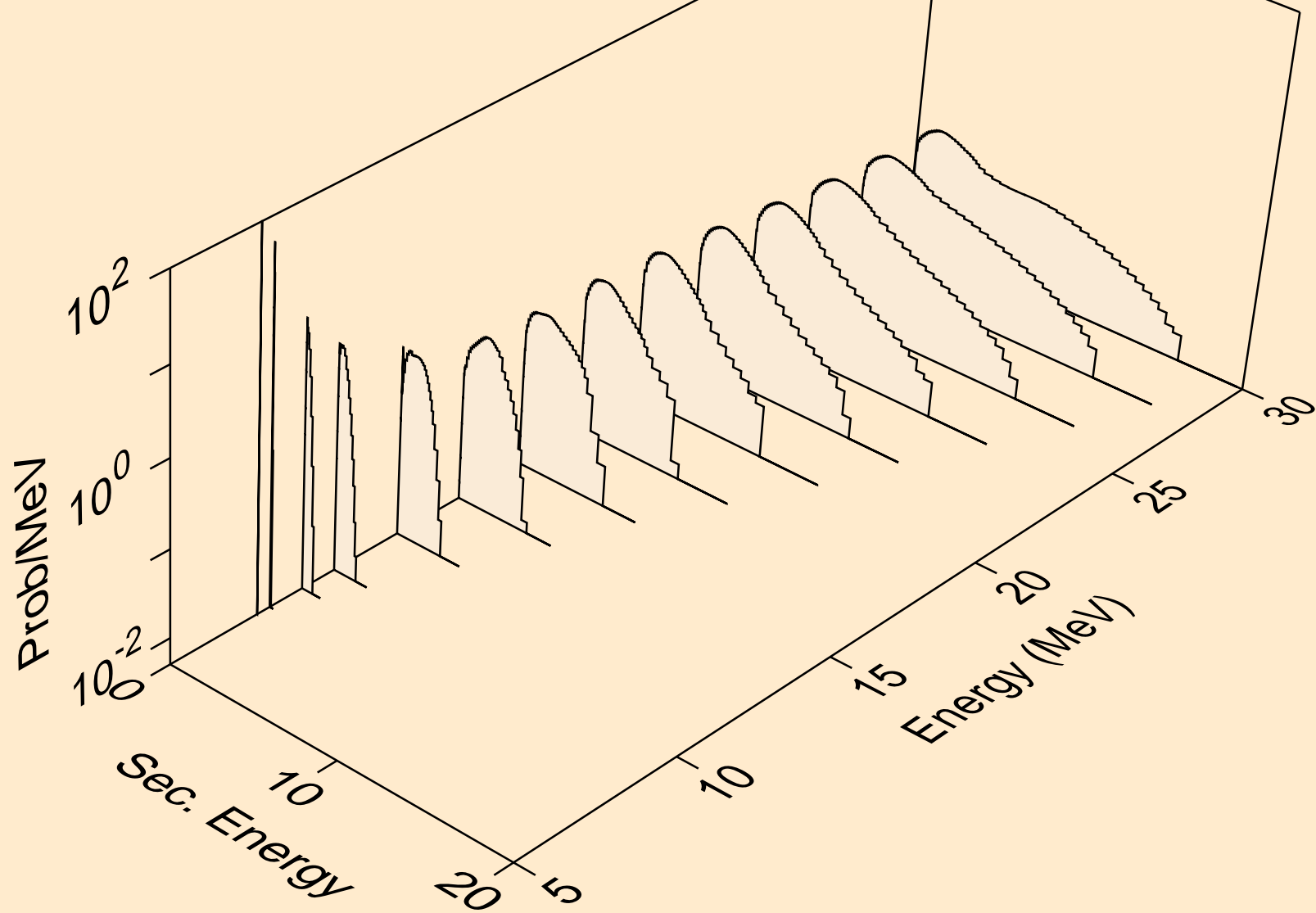

K038 ALPHA ACER TENDL-2024 LIBRARY; T=0.K  
neutrons from (a,n\*)2a

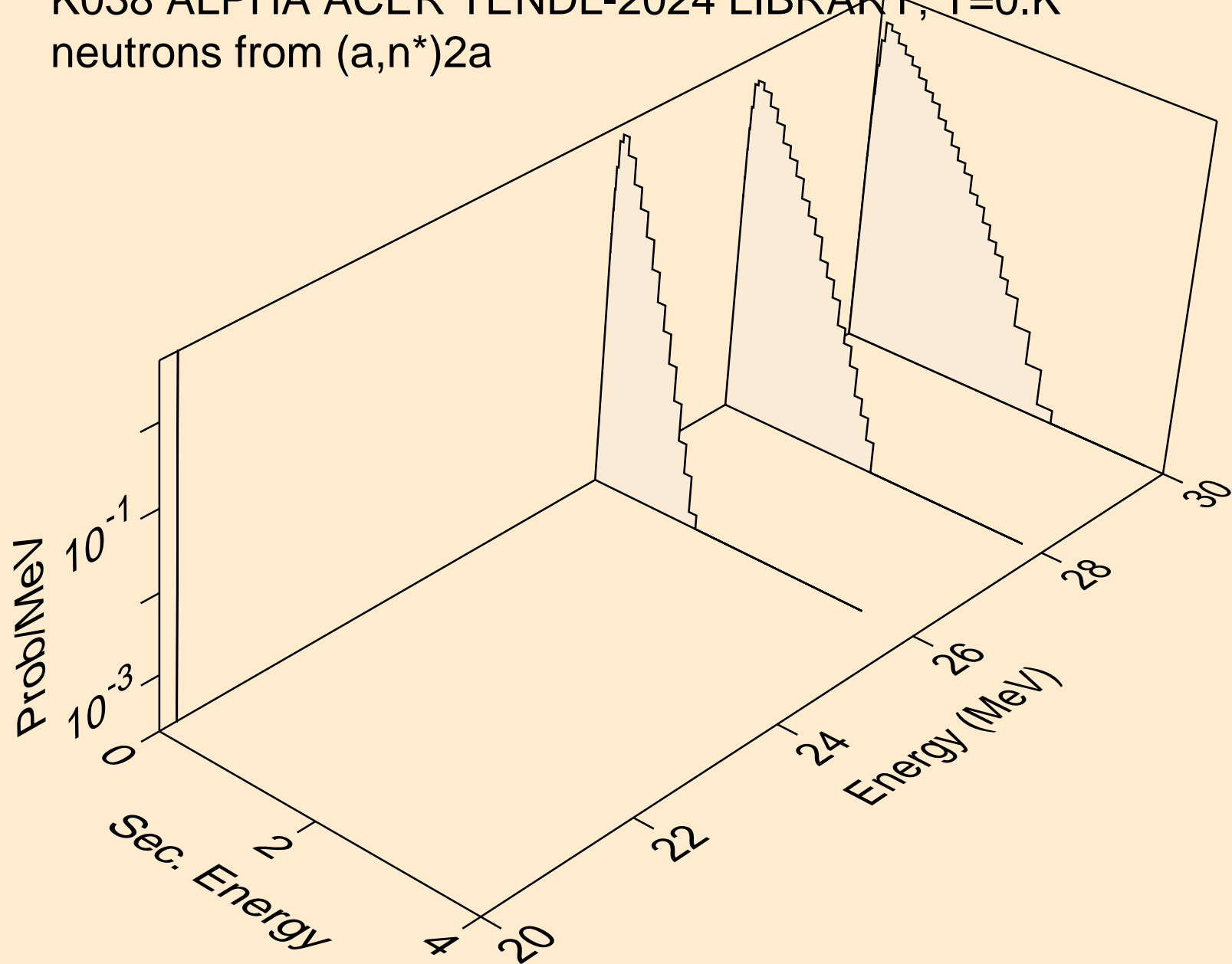

K038 ALPHA ACER TENDL-2024 LIBRARY; T=0.K  
neutrons from (a,n\*)d

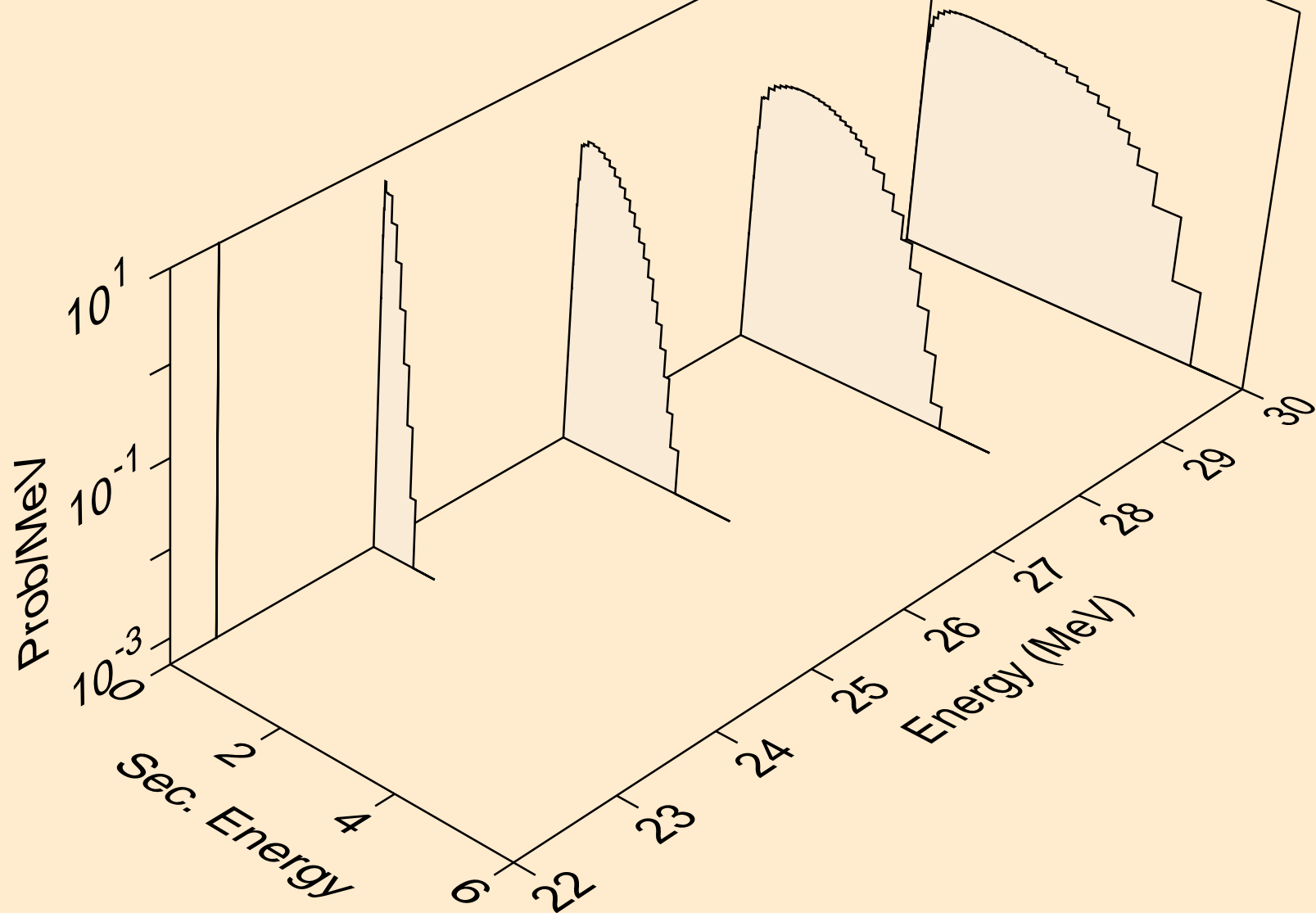

K038 ALPHA ACER TENDL-2024 LIBRARY; T=0.K  
neutrons from (a,n\*)he3

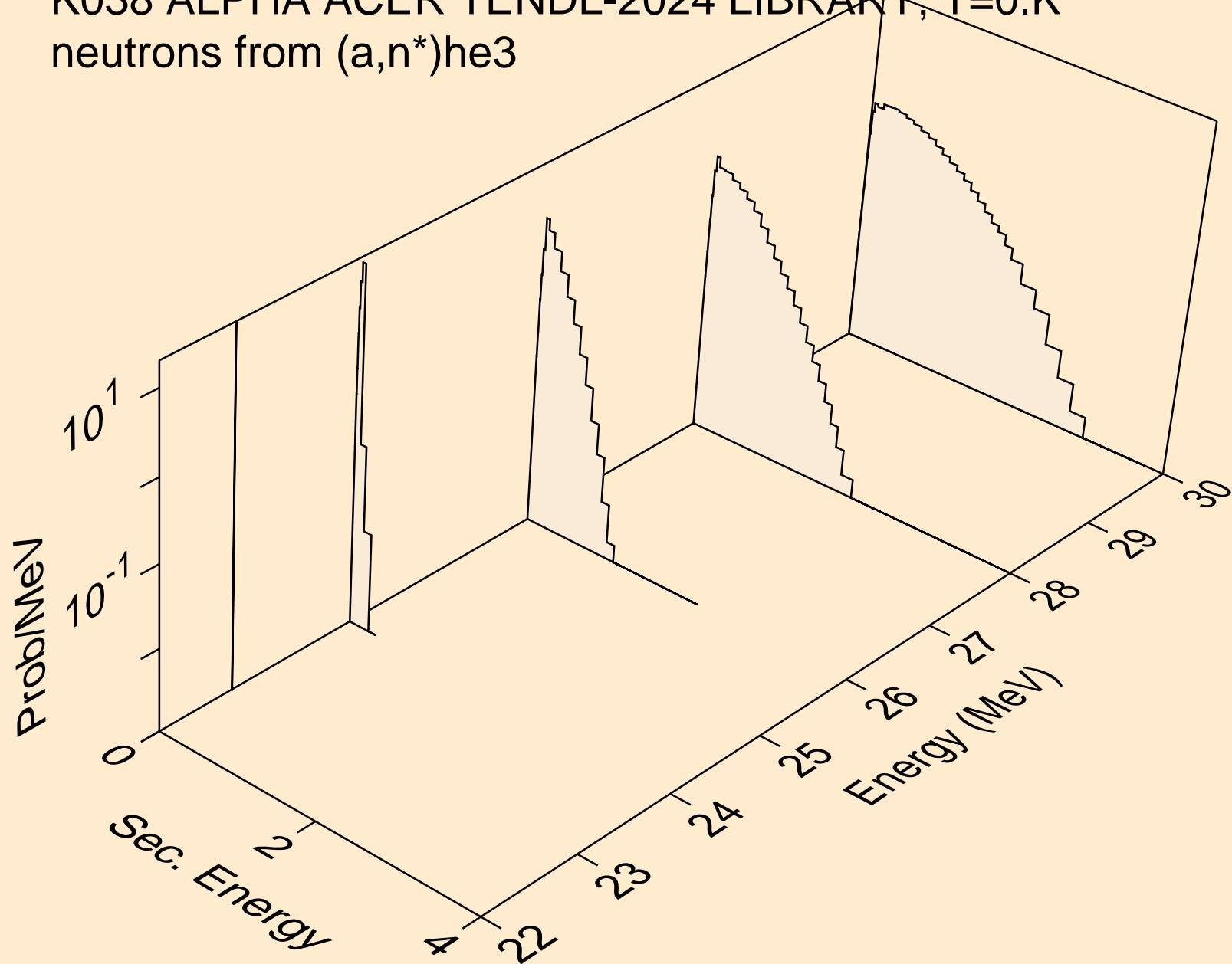

K038 ALPHA ACER TENDL-2024 LIBRARY; T=0.K  
neutrons from (a,2np)

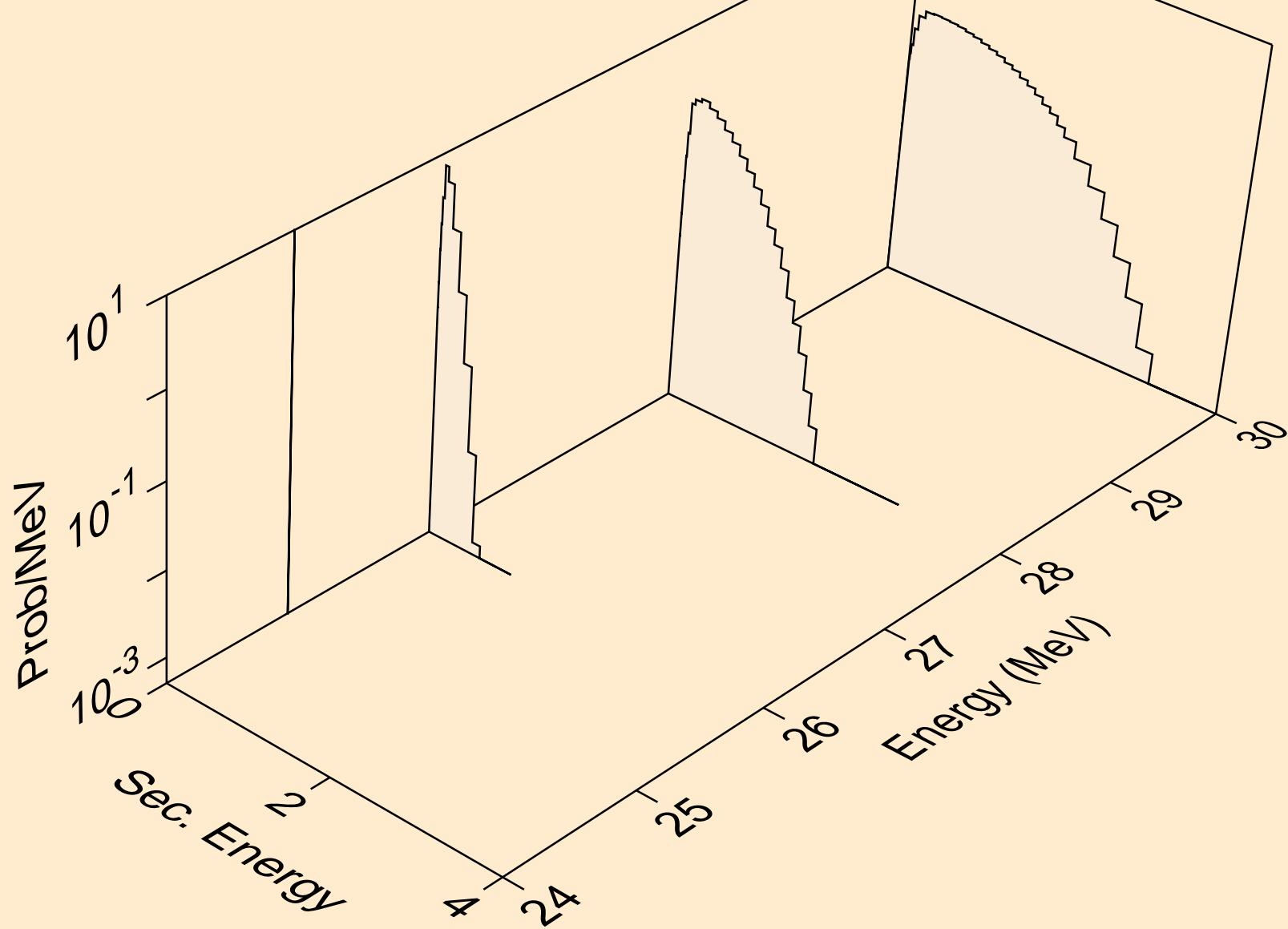

K038 ALPHA ACER TENDL-2024 LIBRARY; T=0.K  
neutrons from (a,n2p)

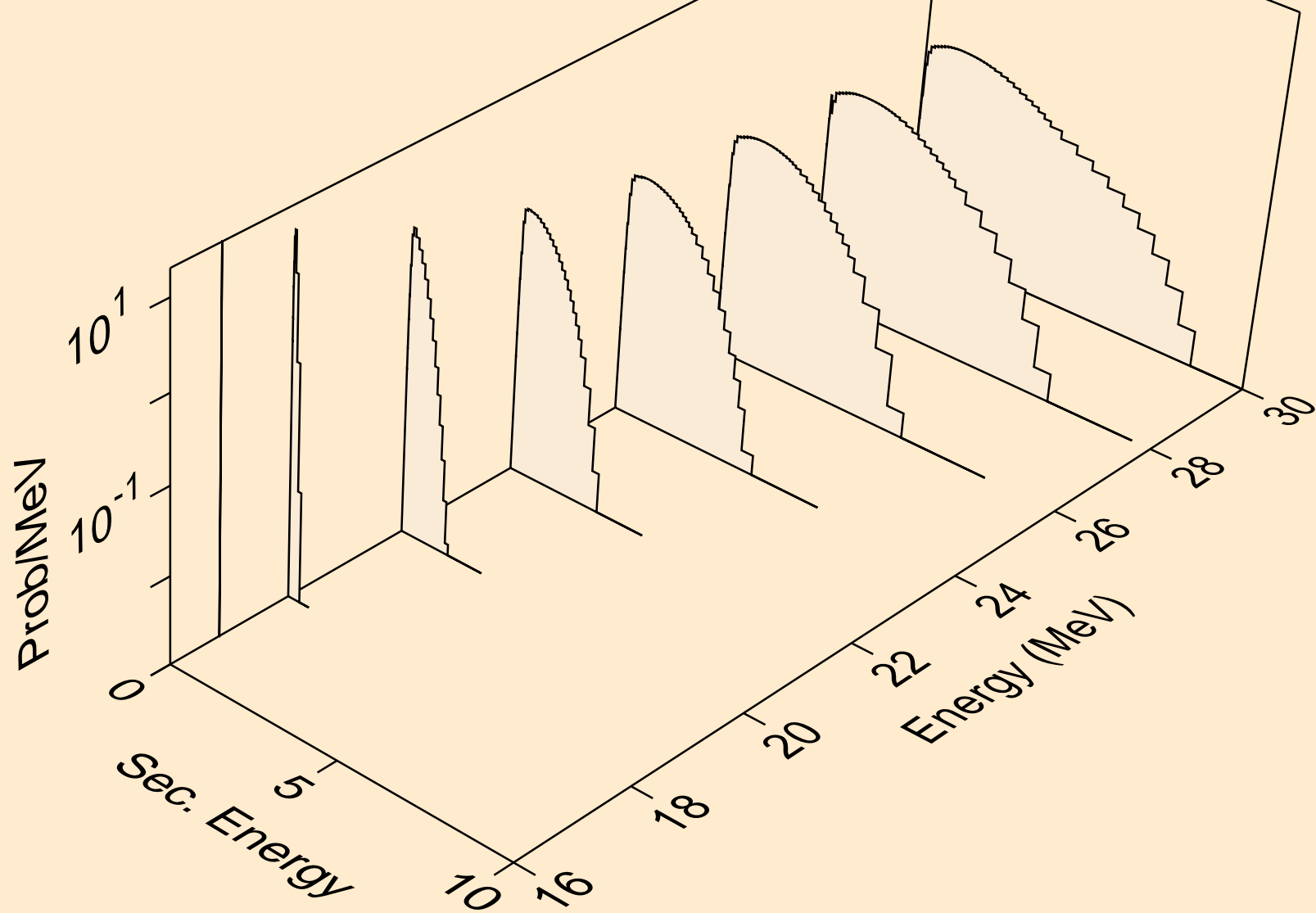

K038 ALPHA ACER TENDL-2024 LIBRARY; T=0.K  
neutrons from (a,npa)

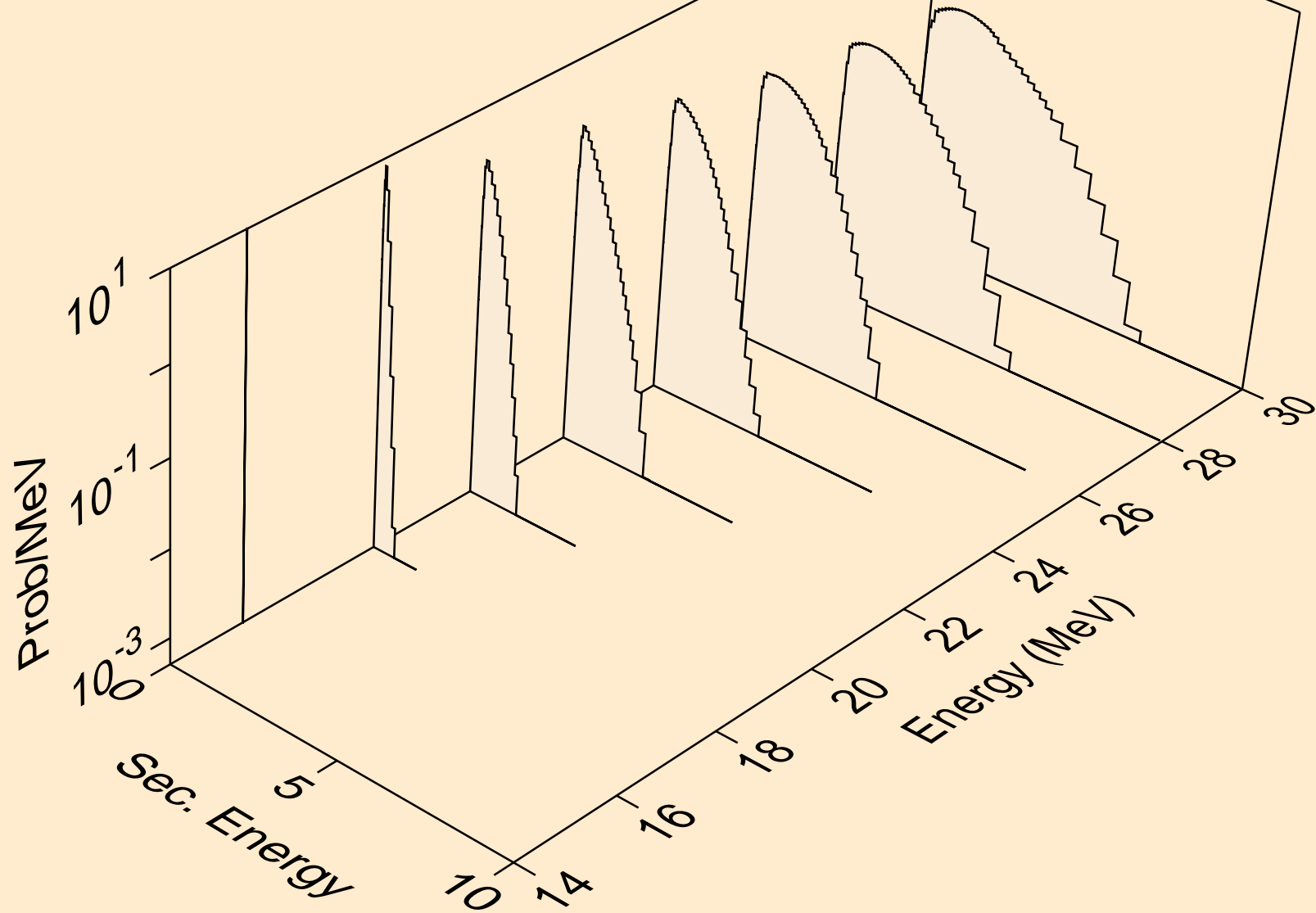

K038 ALPHA ACER TENDL-2024 LIBRARY; T=0.K  
protons from (a,x)

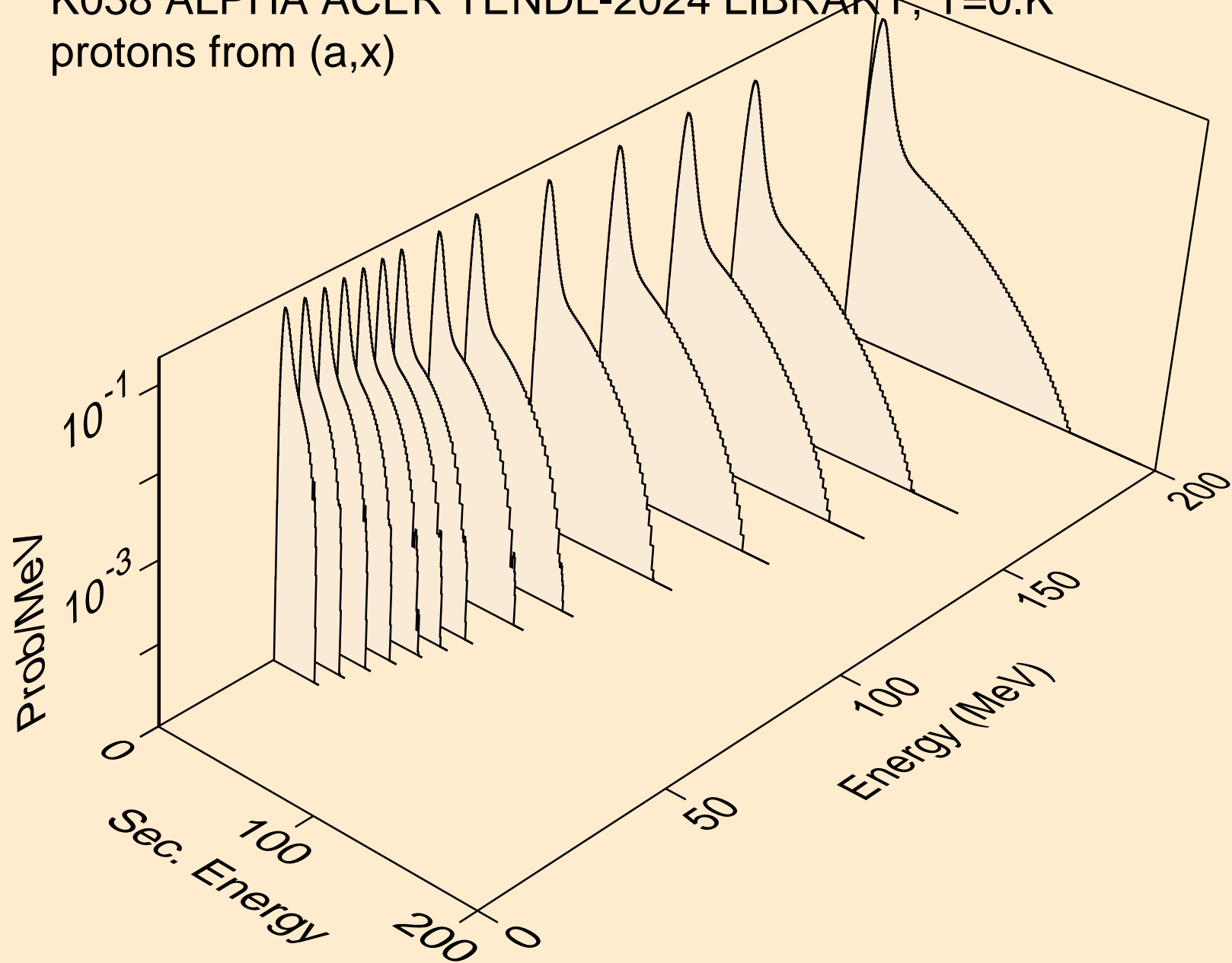

K038 ALPHA ACER TENDL-2024 LIBRARY; T=0.K  
protons from (a,n\*)p

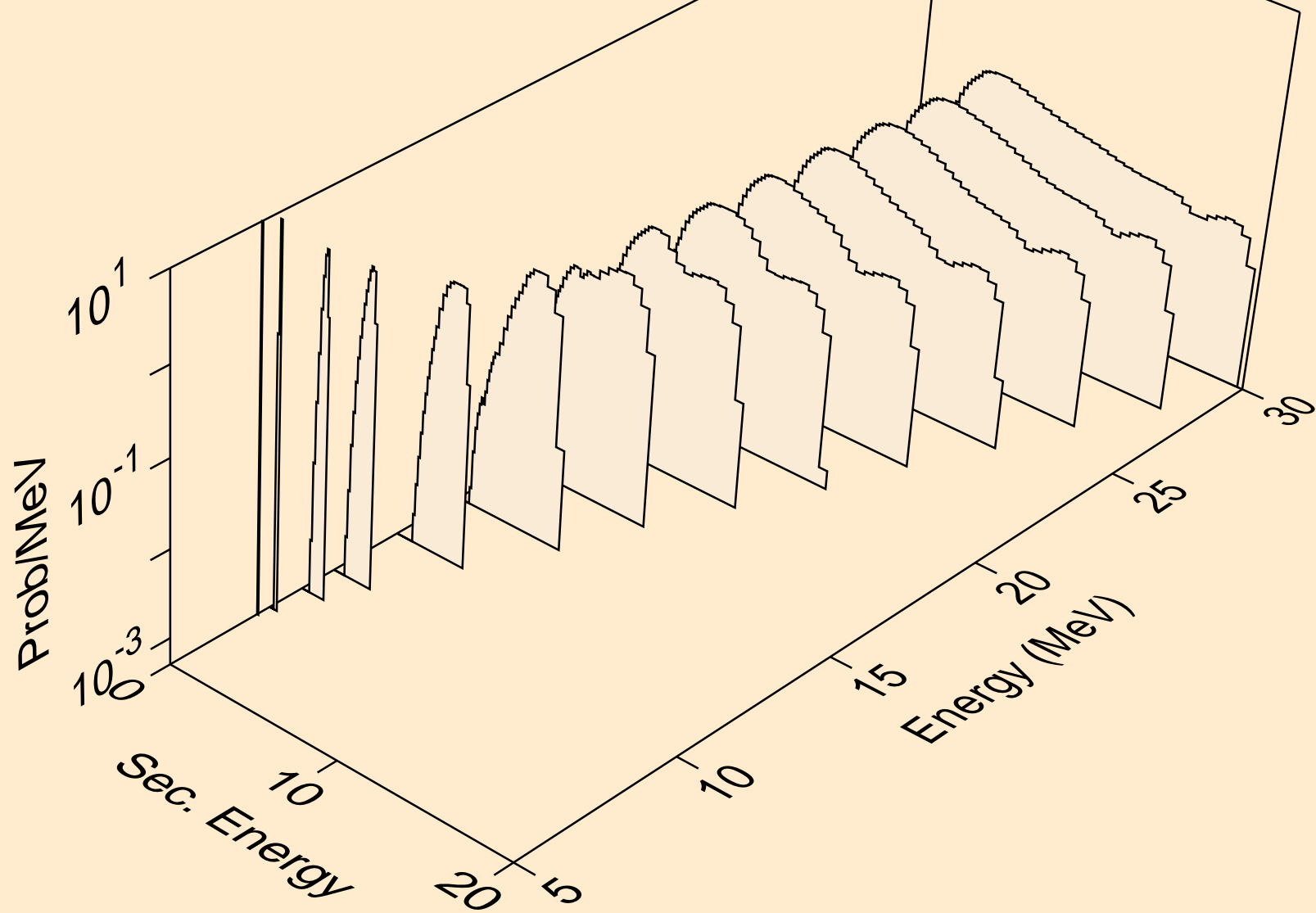

K038 ALPHA ACER TENDL-2024 LIBRARY; T=0.K  
protons from (a,2np)

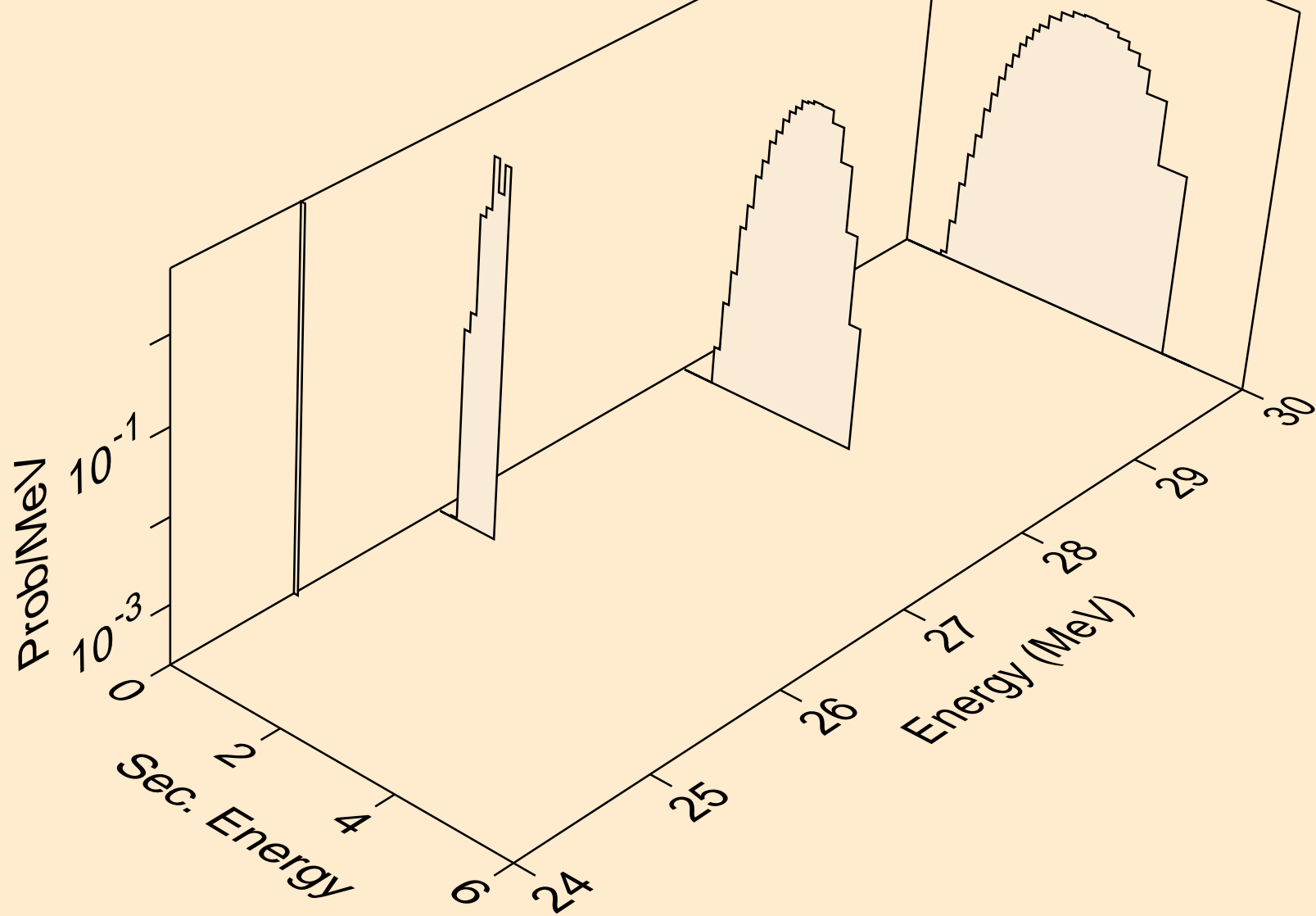

K038 ALPHA ACER TENDL-2024 LIBRARY; T=0.K  
protons from (a,n2p)

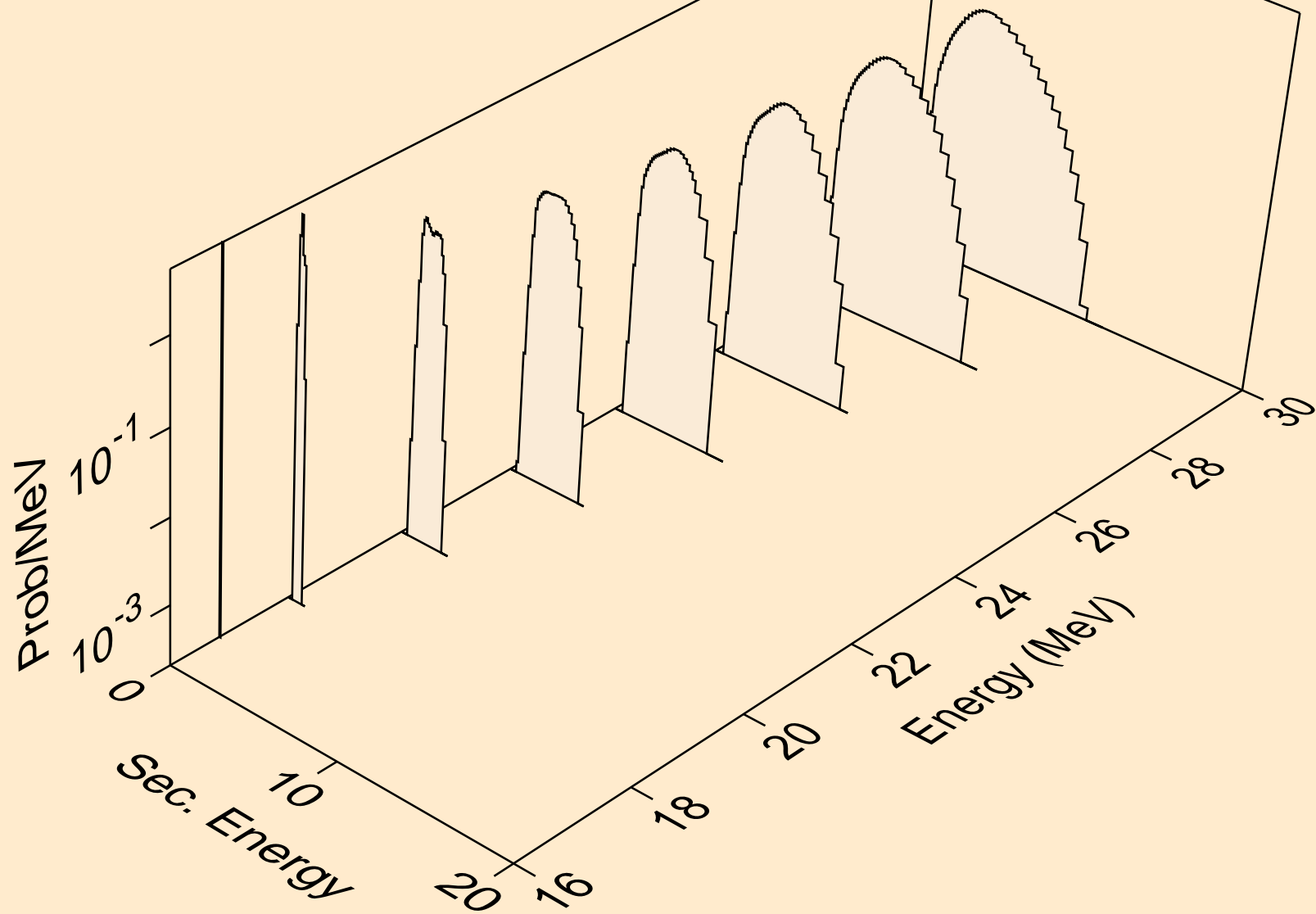

K038 ALPHA ACER TENDL-2024 LIBRARY; T=0.K  
protons from (a,npa)

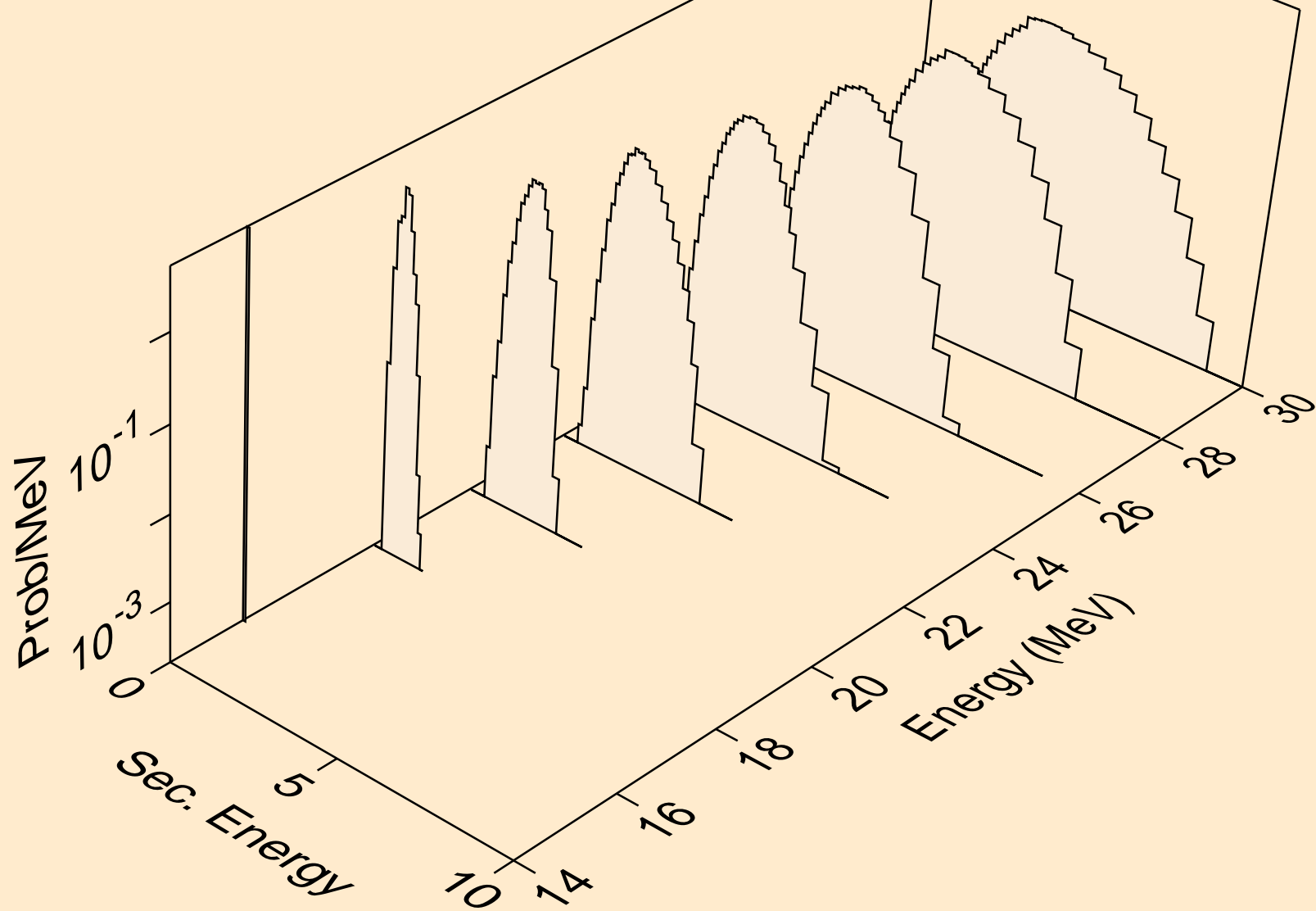

K038 ALPHA ACER TENDL-2024 LIBRARY; T=0.K  
protons from (a,p)

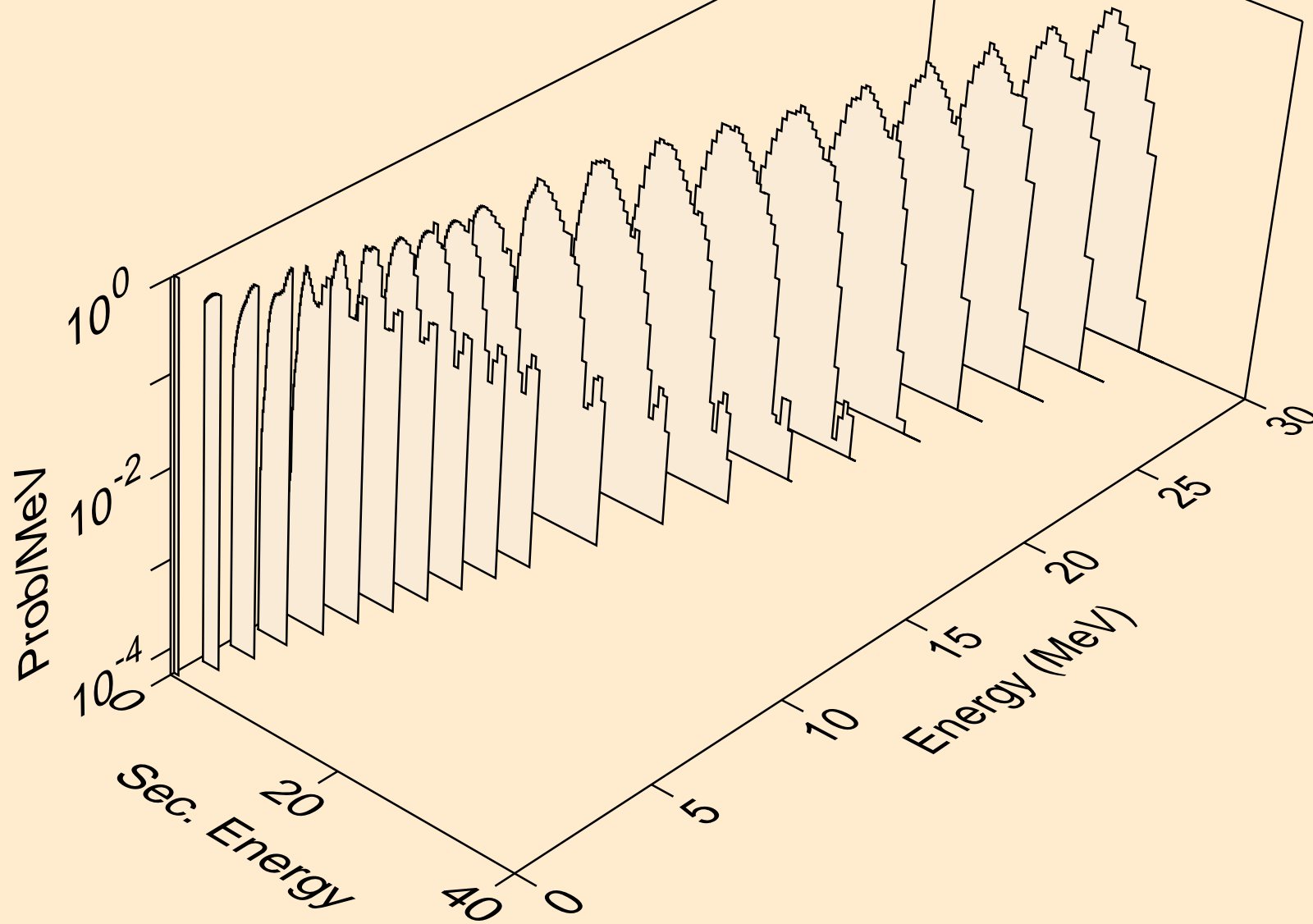

K038 ALPHA ACER TENDL-2024 LIBRARY; T=0.K  
protons from (a,2p)

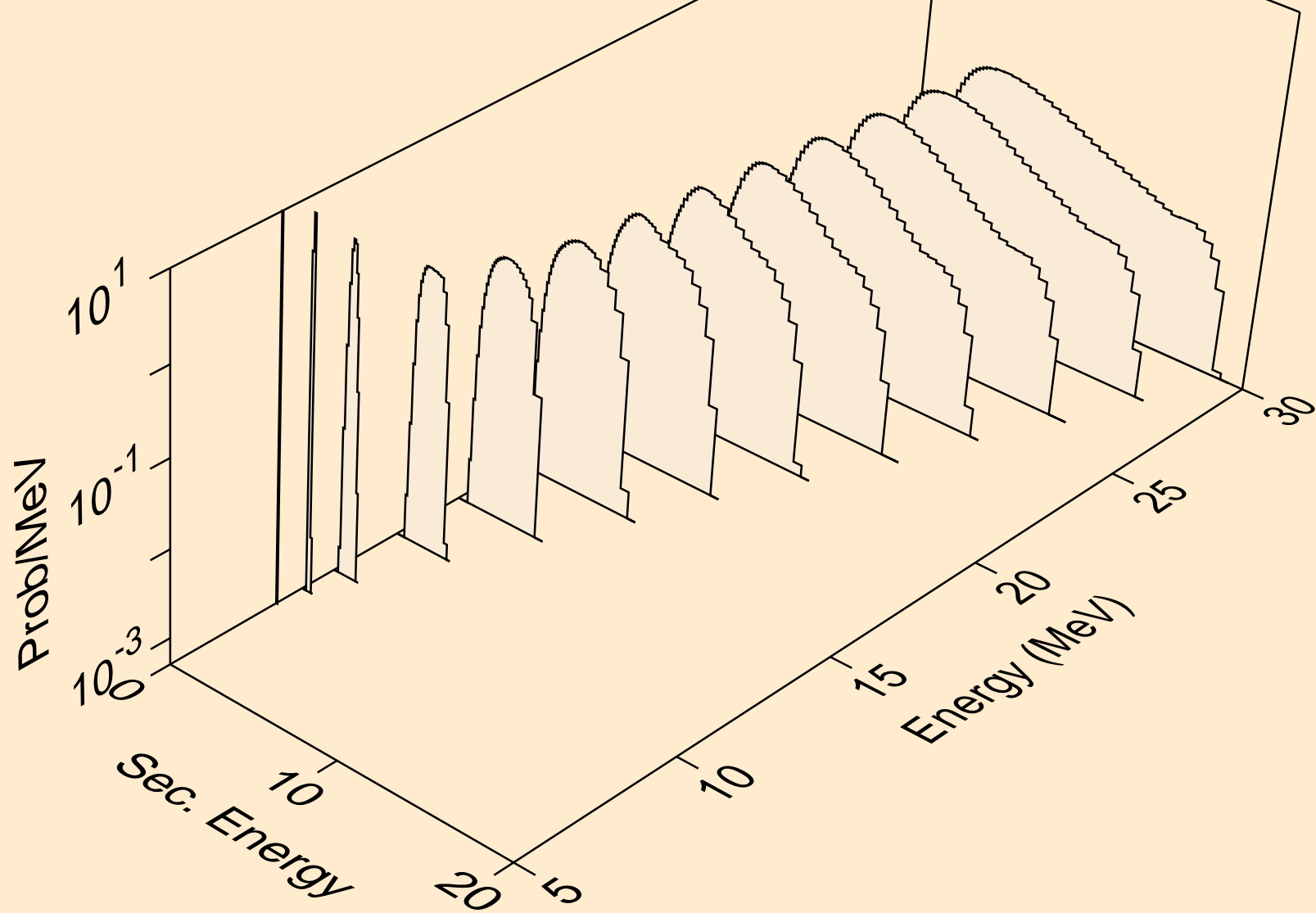

K038 ALPHA ACER TENDL-2024 LIBRARY; T=0.K  
protons from (a,pa)

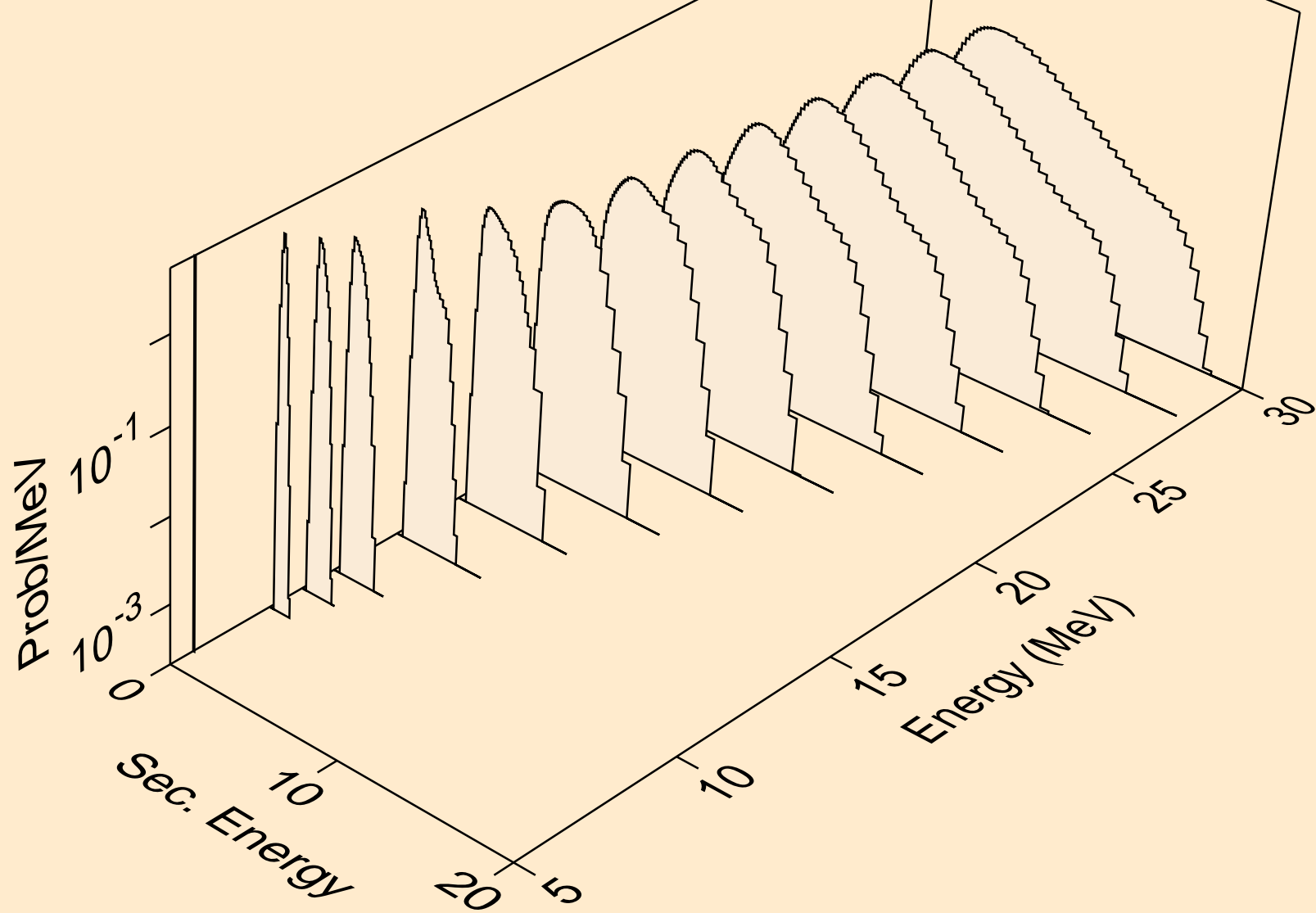

K038 ALPHA ACER TENDL-2024 LIBRARY; T=0.K  
protons from (a,pd)

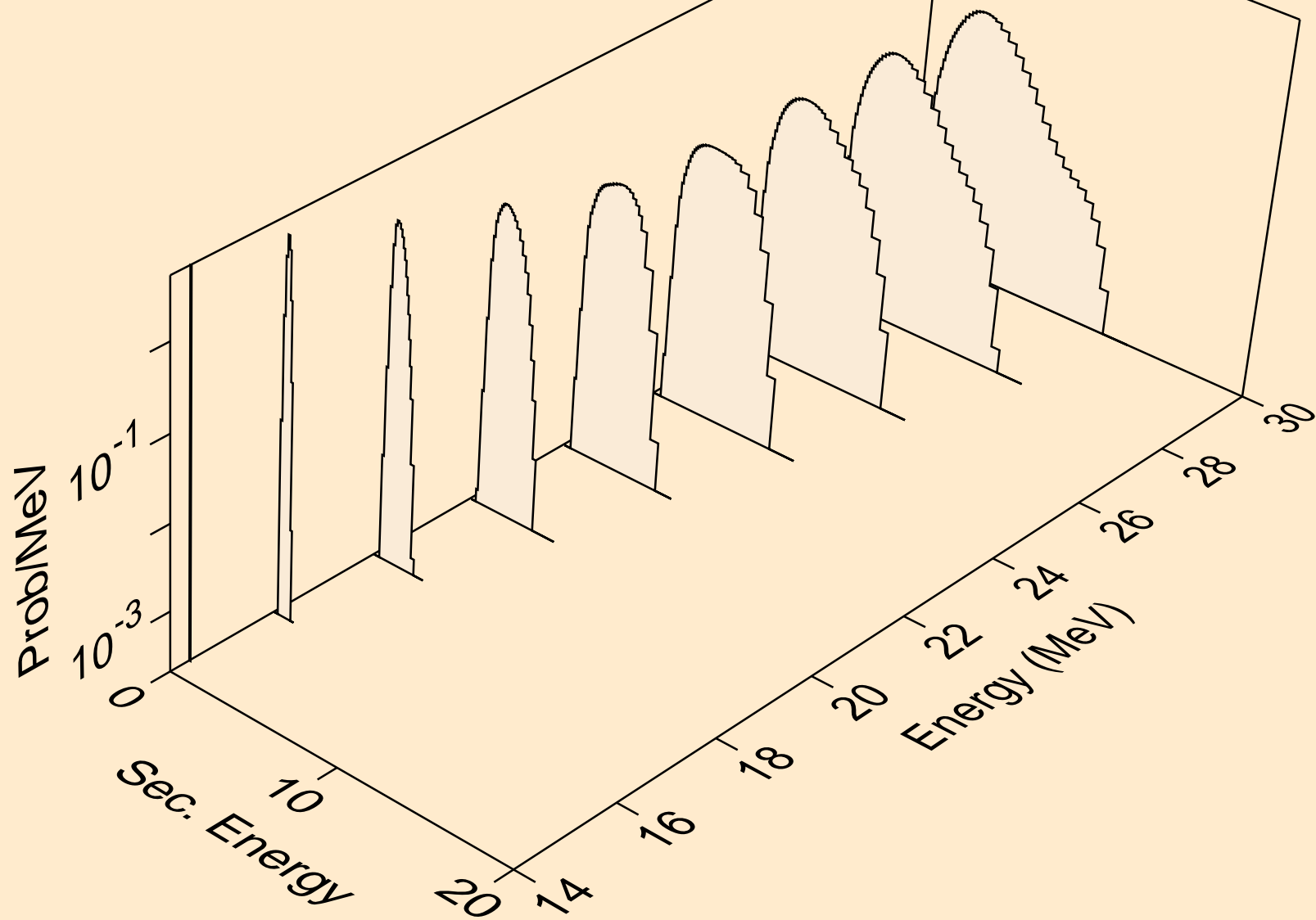

K038 ALPHA ACER TENDL-2024 LIBRARY; T=0.K  
protons from (a,pt)

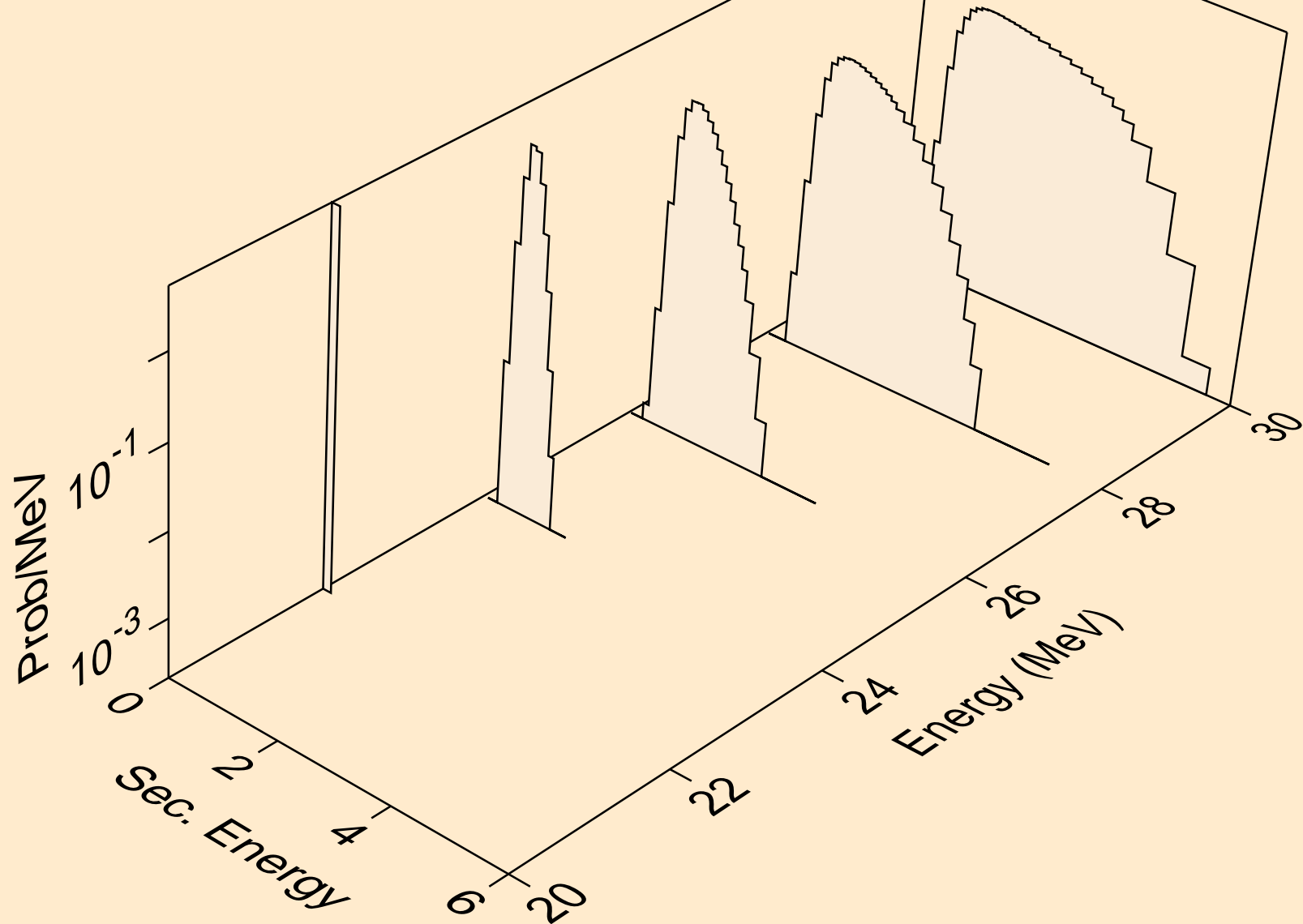

K038 ALPHA ACER TENDL-2024 LIBRARY; T=0.K  
deuterons from (a,x)

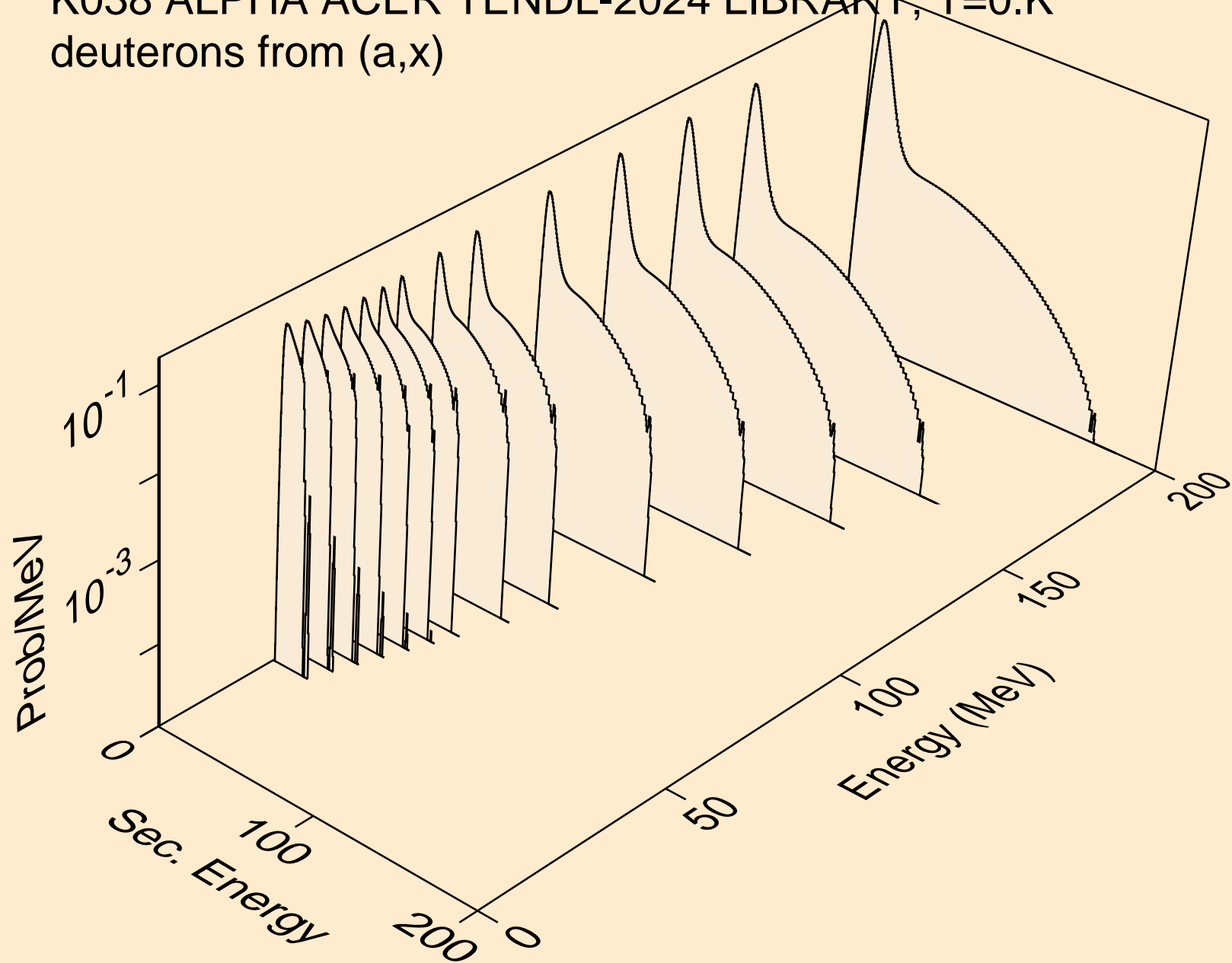

K038 ALPHA ACER TENDL-2024 LIBRARY; T=0.K  
deuterons from (a,n\*)d

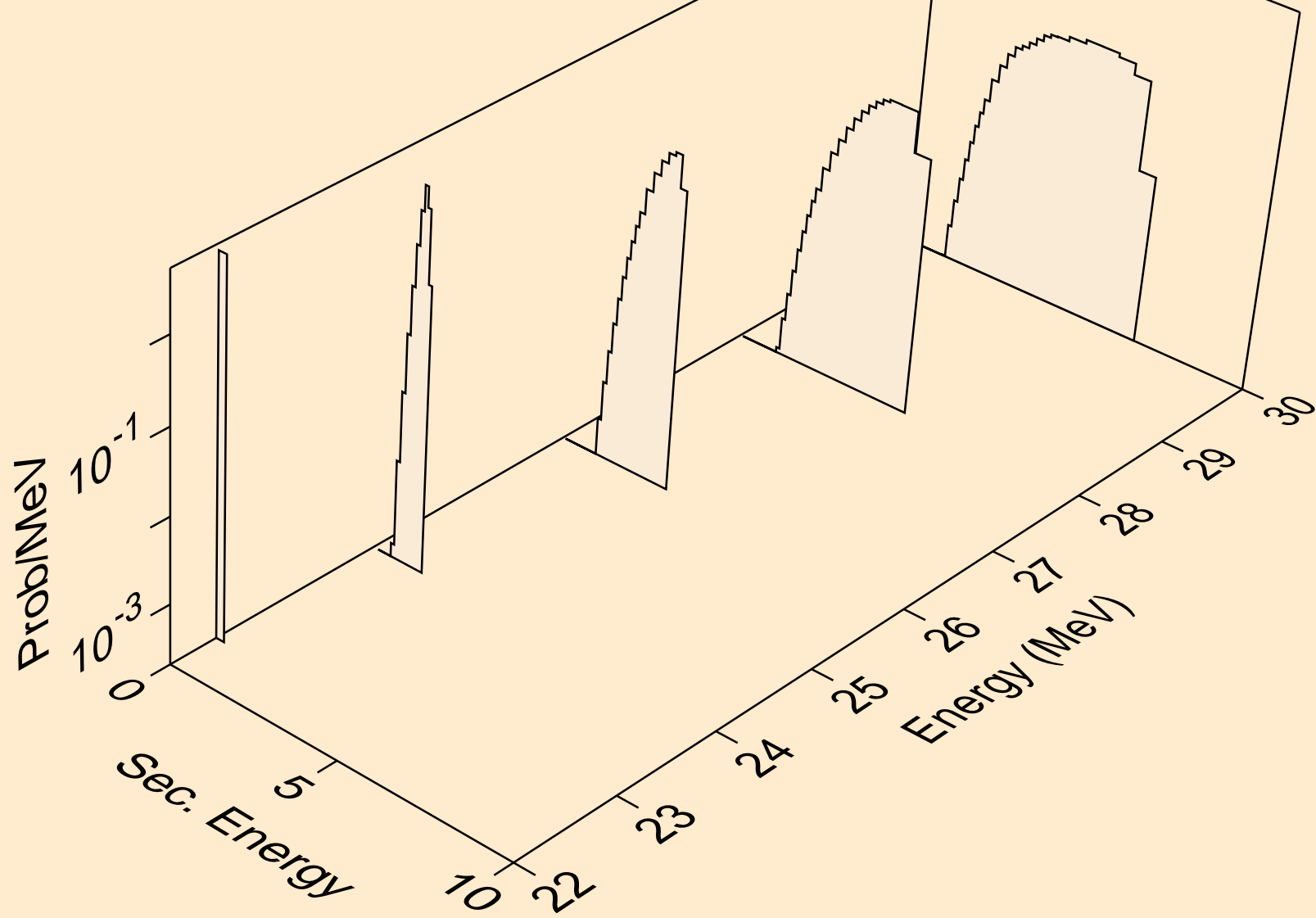

K038 ALPHA ACER TENDL-2024 LIBRARY; T=0.K  
deuterons from (a,d)

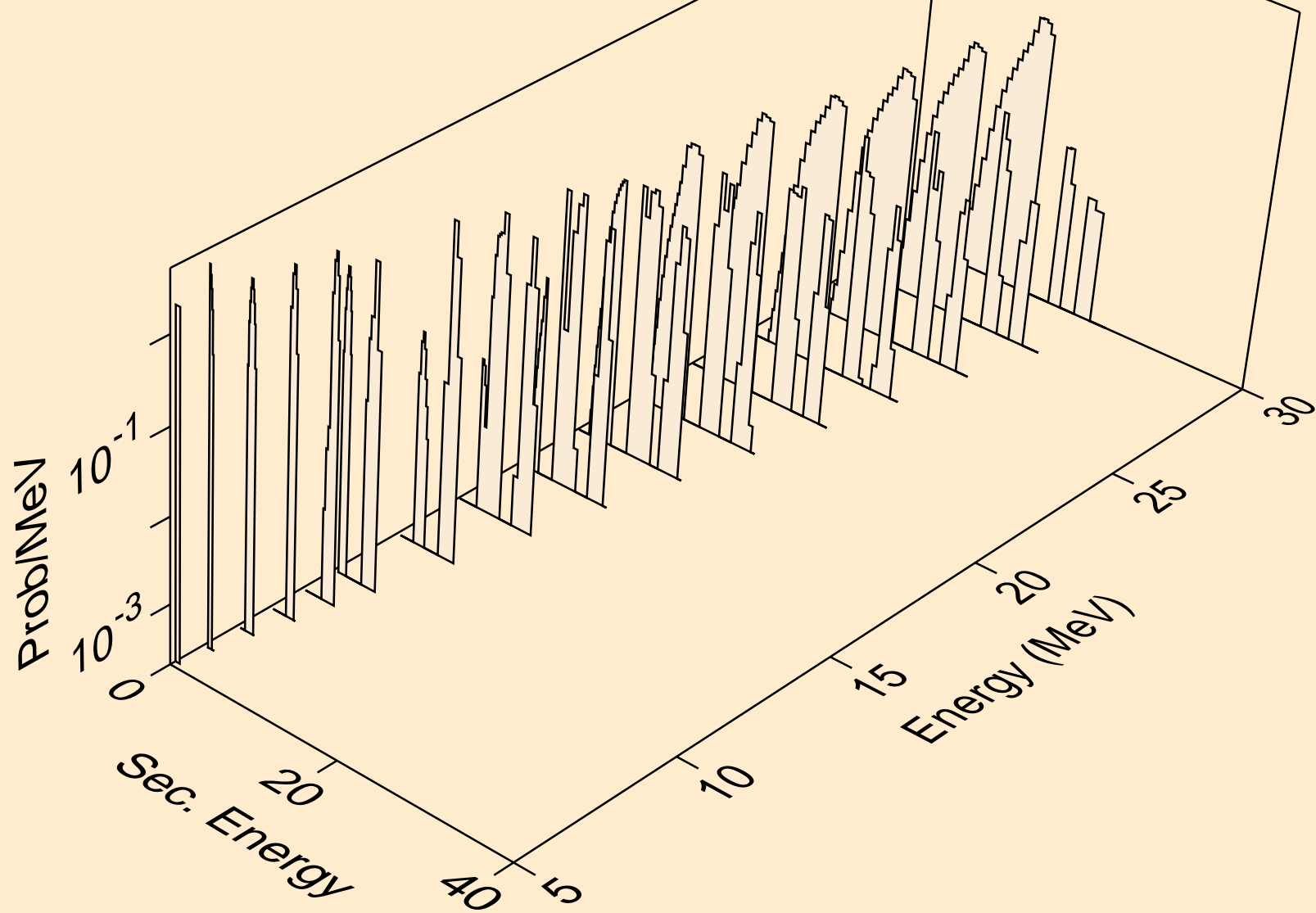

K038 ALPHA ACER TENDL-2024 LIBRARY; T=0.K  
deuterons from (a,pd)

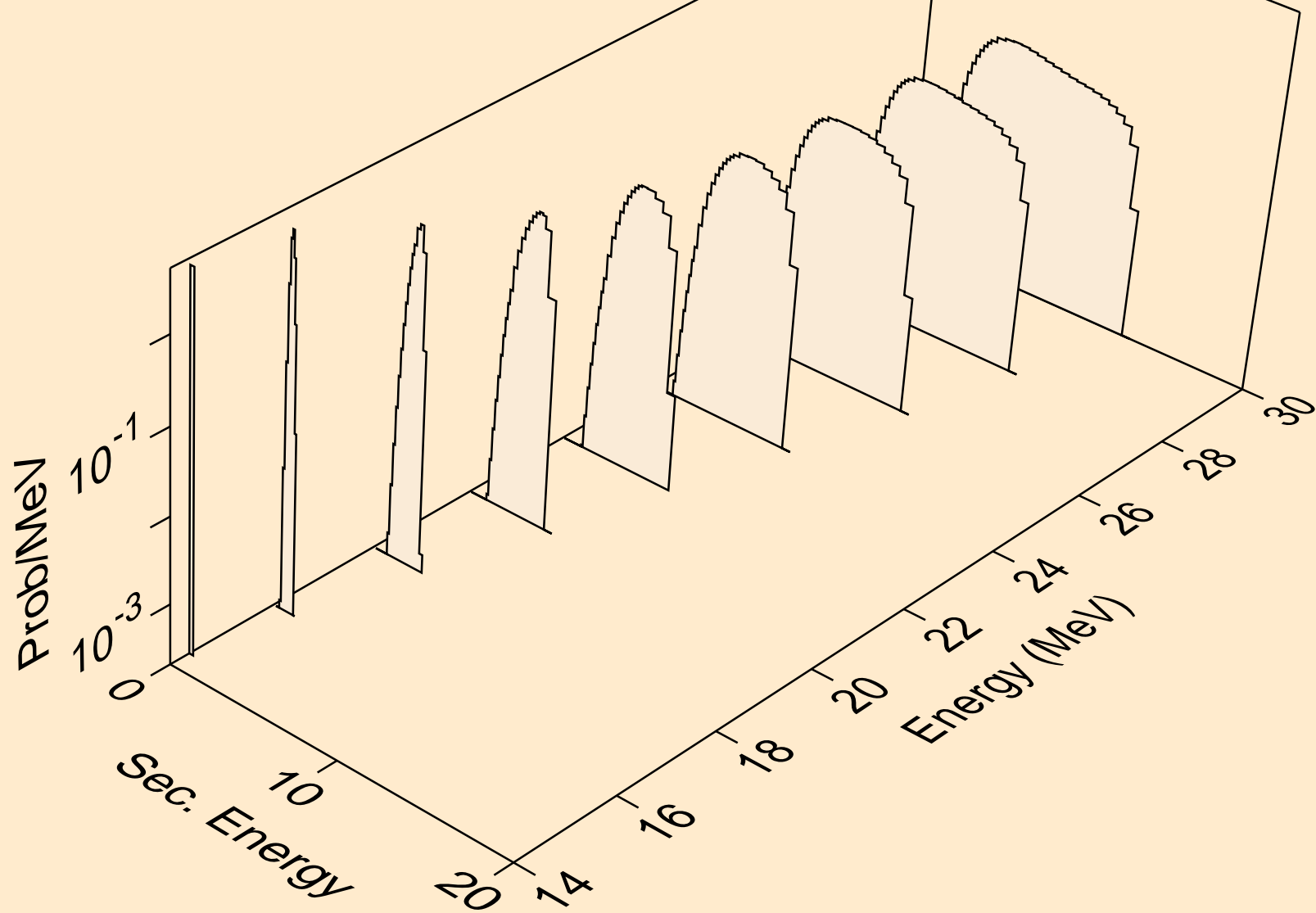

K038 ALPHA ACER TENDL-2024 LIBRARY; T=0.K  
deuterons from (a,da)

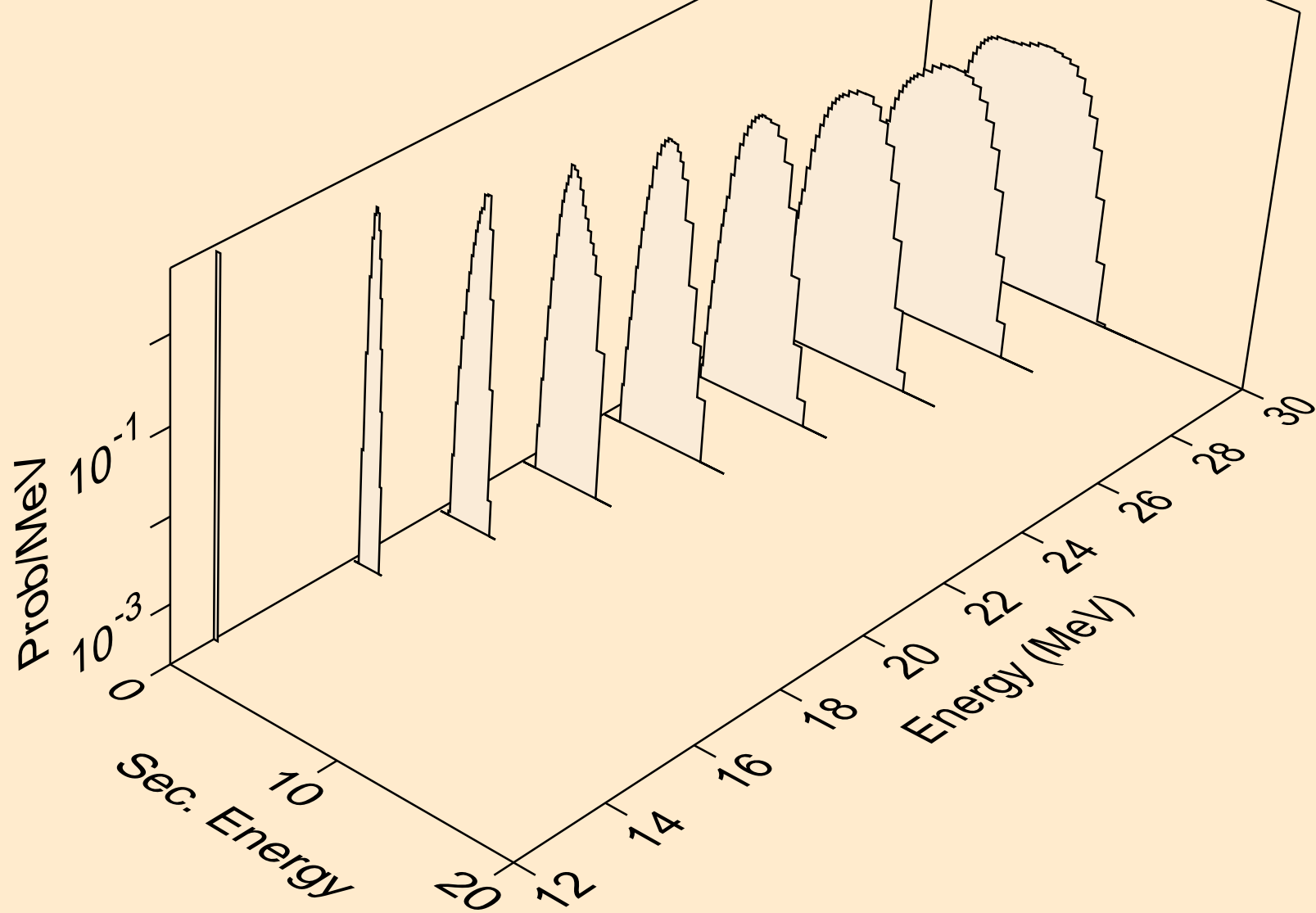

K038 ALPHA ACER TENDL-2024 LIBRARY; T=0.K  
tritons from (a,x)

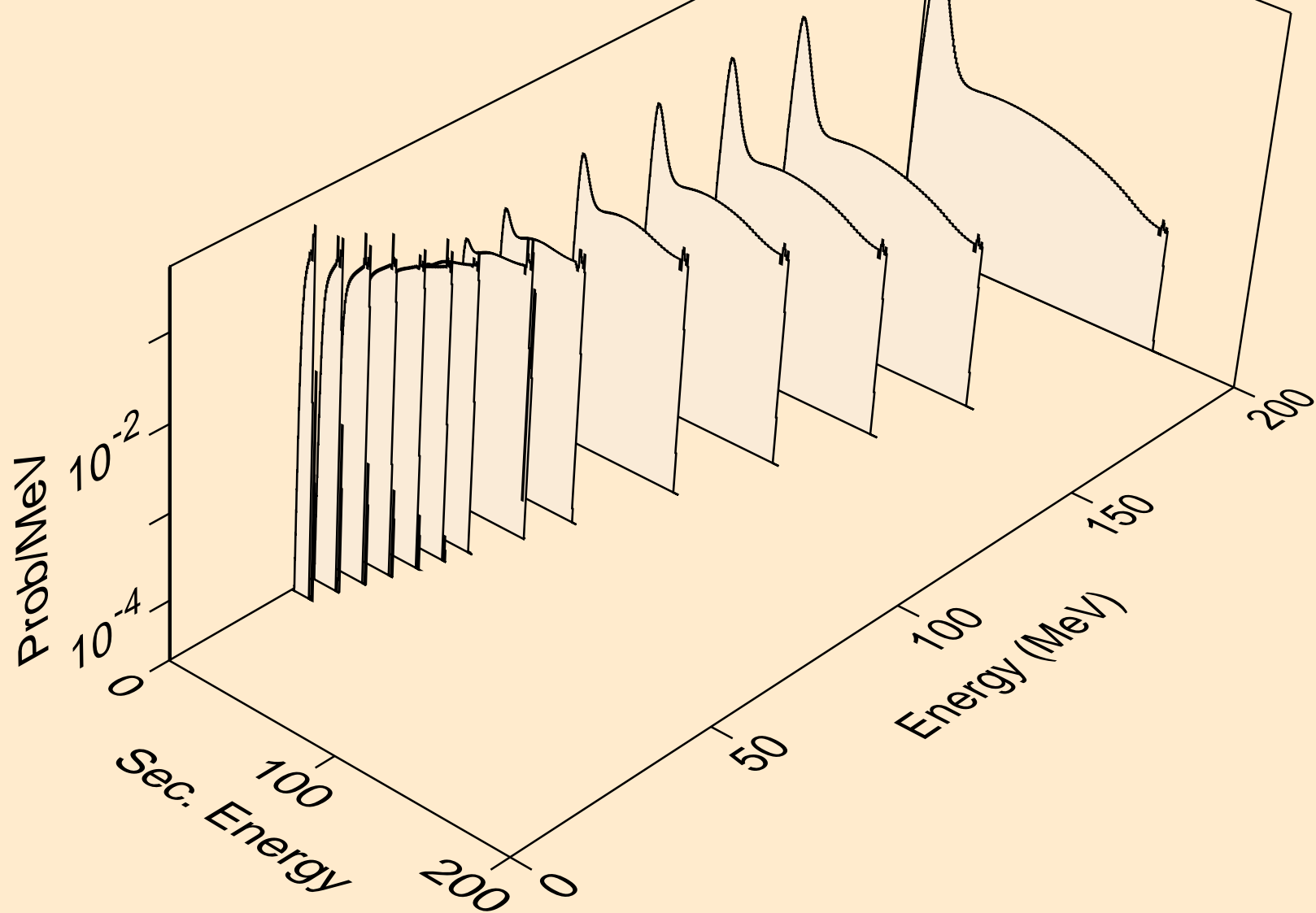

K038 ALPHA ACER TENDL-2024 LIBRARY; T=0.K  
tritons from (a,t)

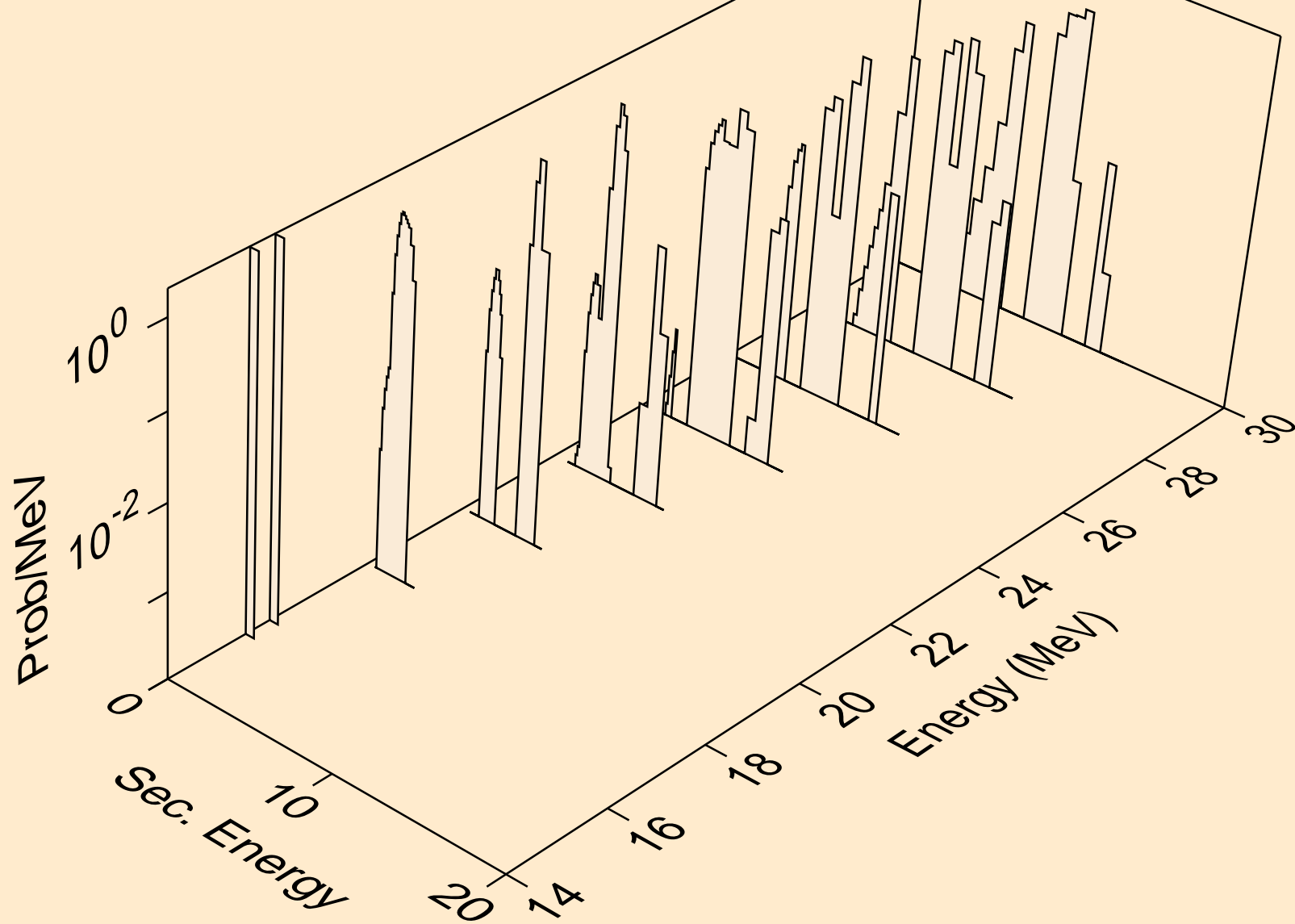

K038 ALPHA ACER TENDL-2024 LIBRARY; T=0.K  
tritons from (a,pt)

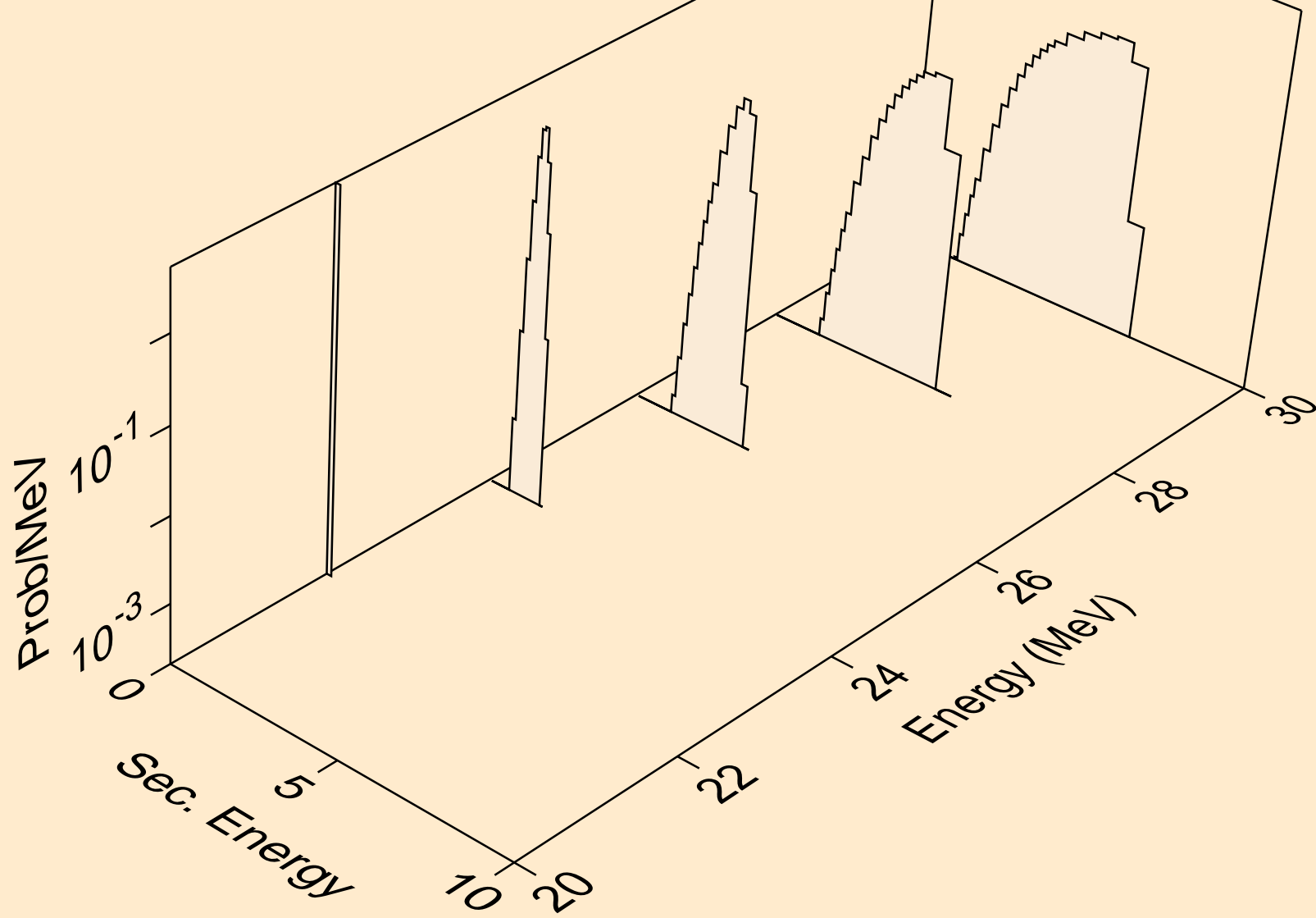

K038 ALPHA ACER TENDL-2024 LIBRARY; T=0.K  
he3s from (a,x)

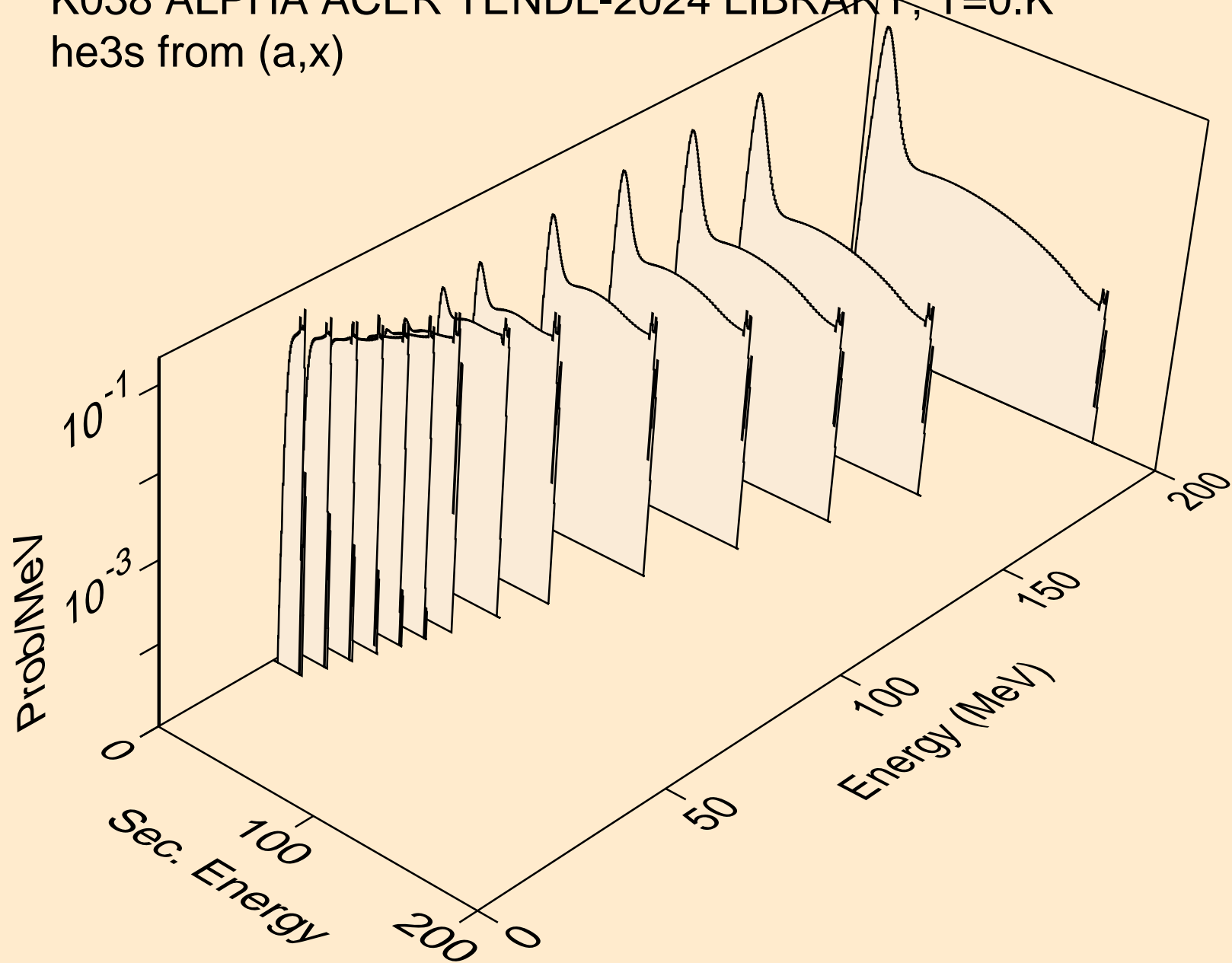

K038 ALPHA ACER TENDL-2024 LIBRARY; T=0.K  
he3s from (a,n\*)he3

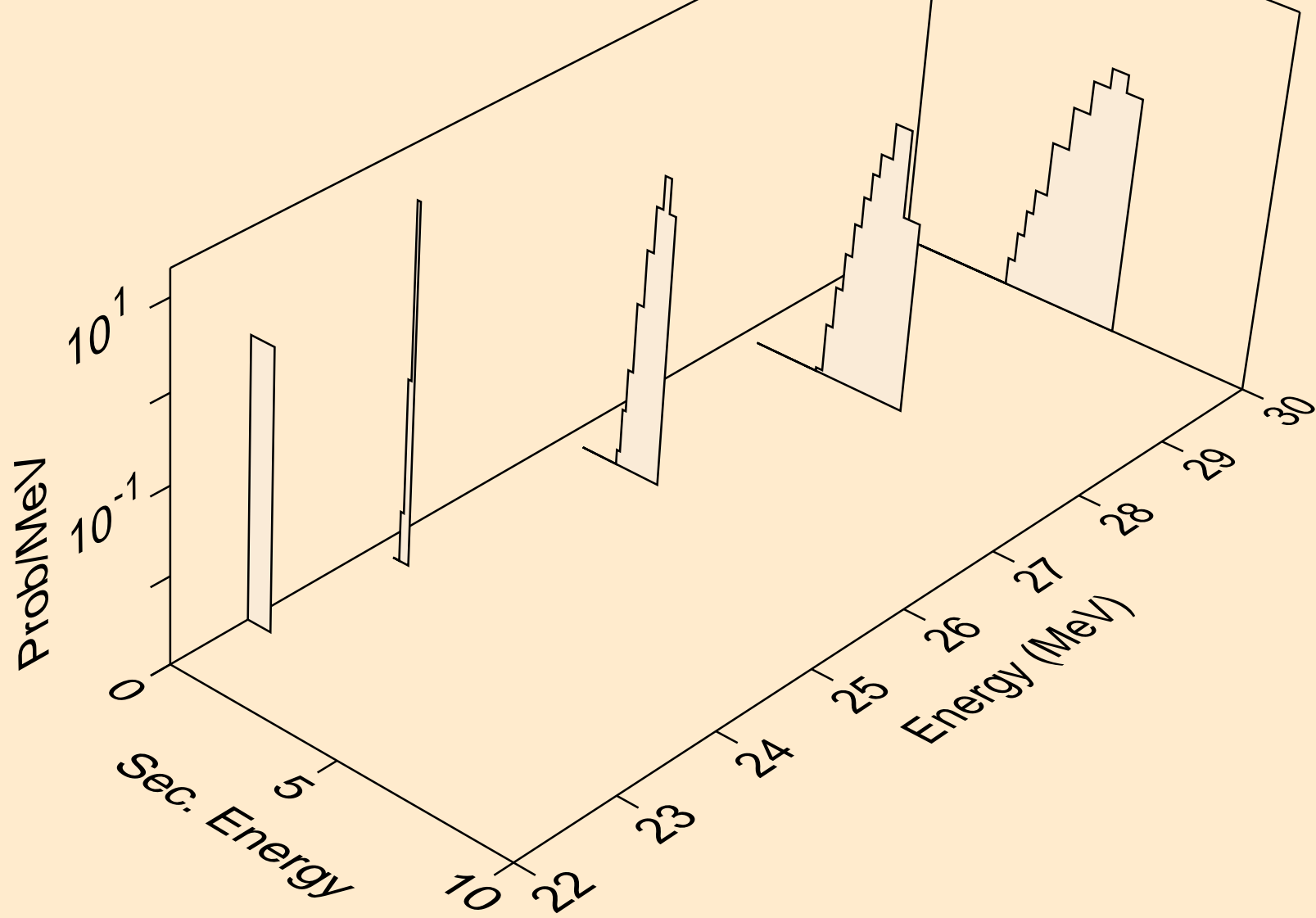

K038 ALPHA ACER TENDL-2024 LIBRARY; T=0.K  
he3s from (a,he3)

