

# K042 ALPHA ACER TENDL-2024 LIBRARY; T=0.K

## Principal cross sections

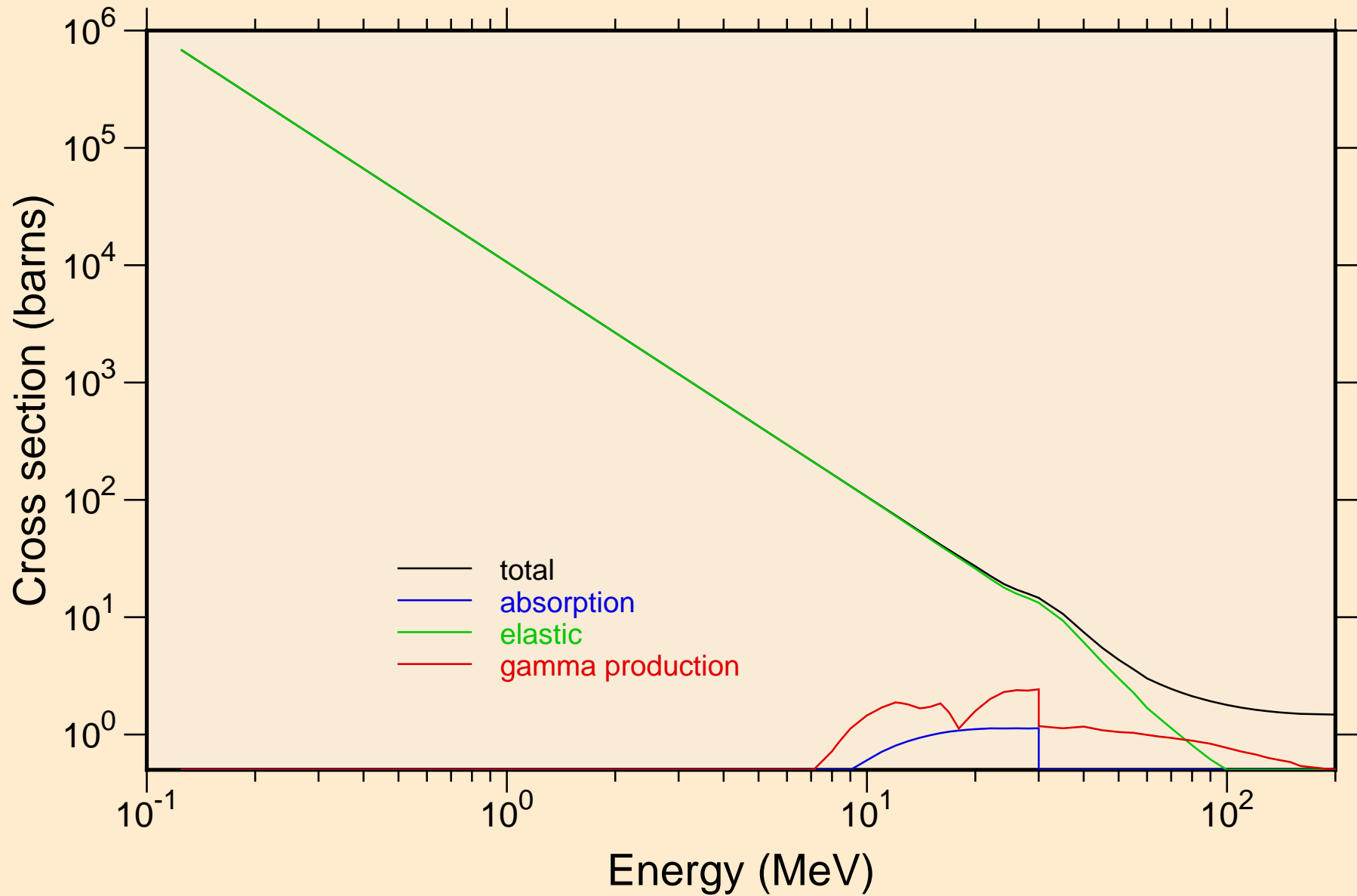

# K042 ALPHA ACER TENDL-2024 LIBRARY; T=0.K

## Heating

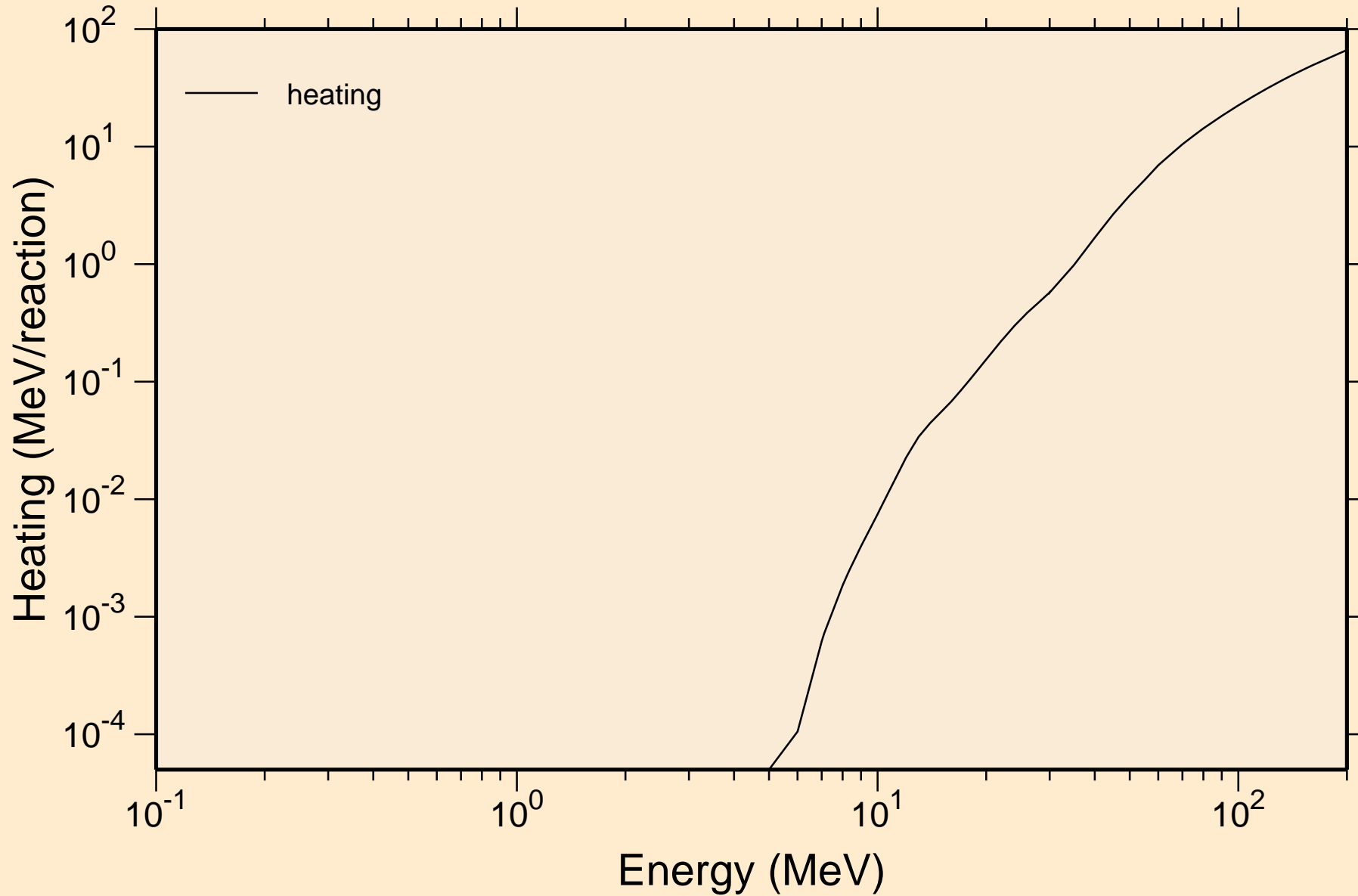

# K042 ALPHA ACER TENDL-2024 LIBRARY; T=0.K

## Principal cross sections

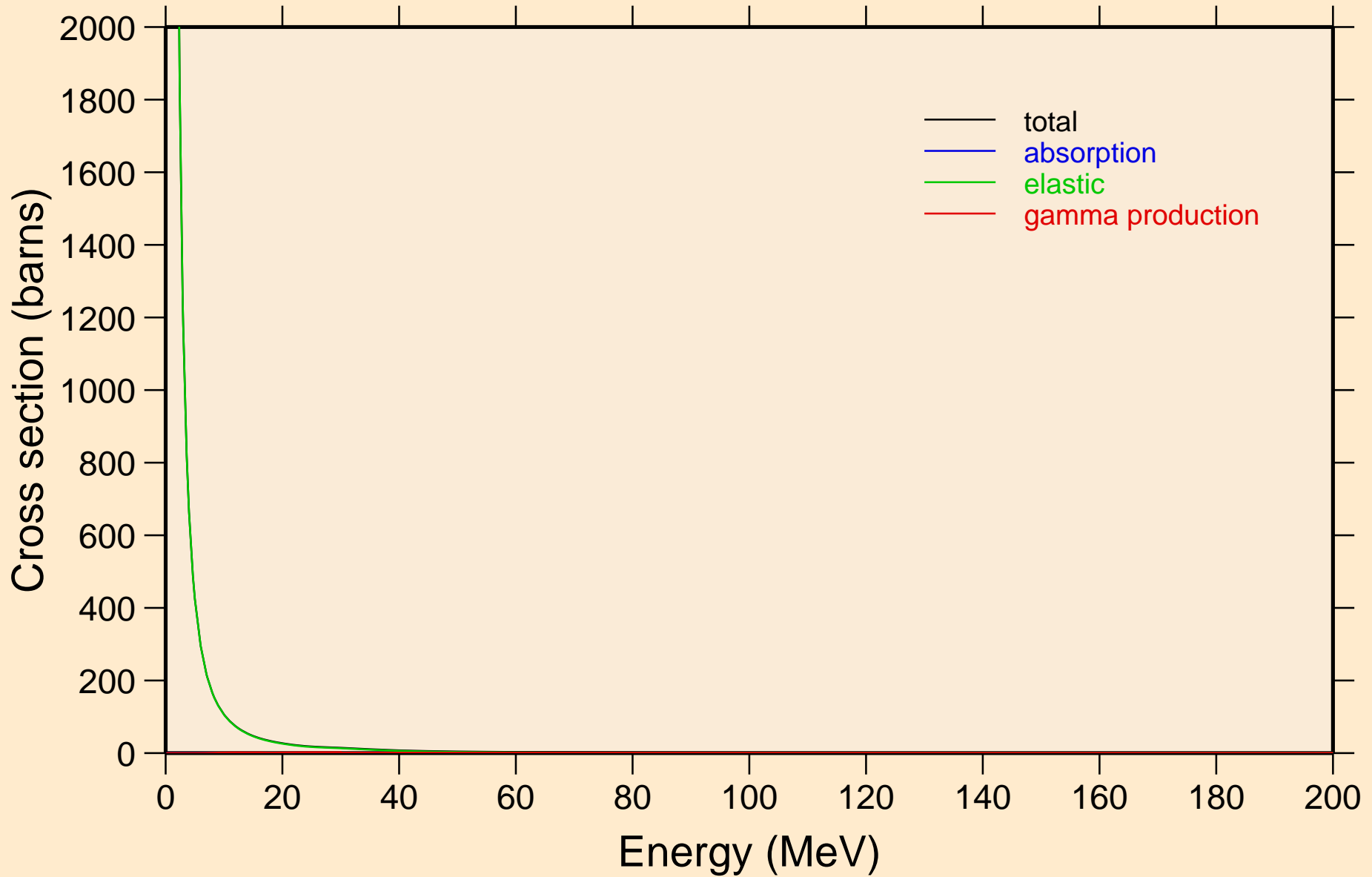

K042 ALPHA ACER TENDL-2024 LIBRARY; T=0.K

Heating

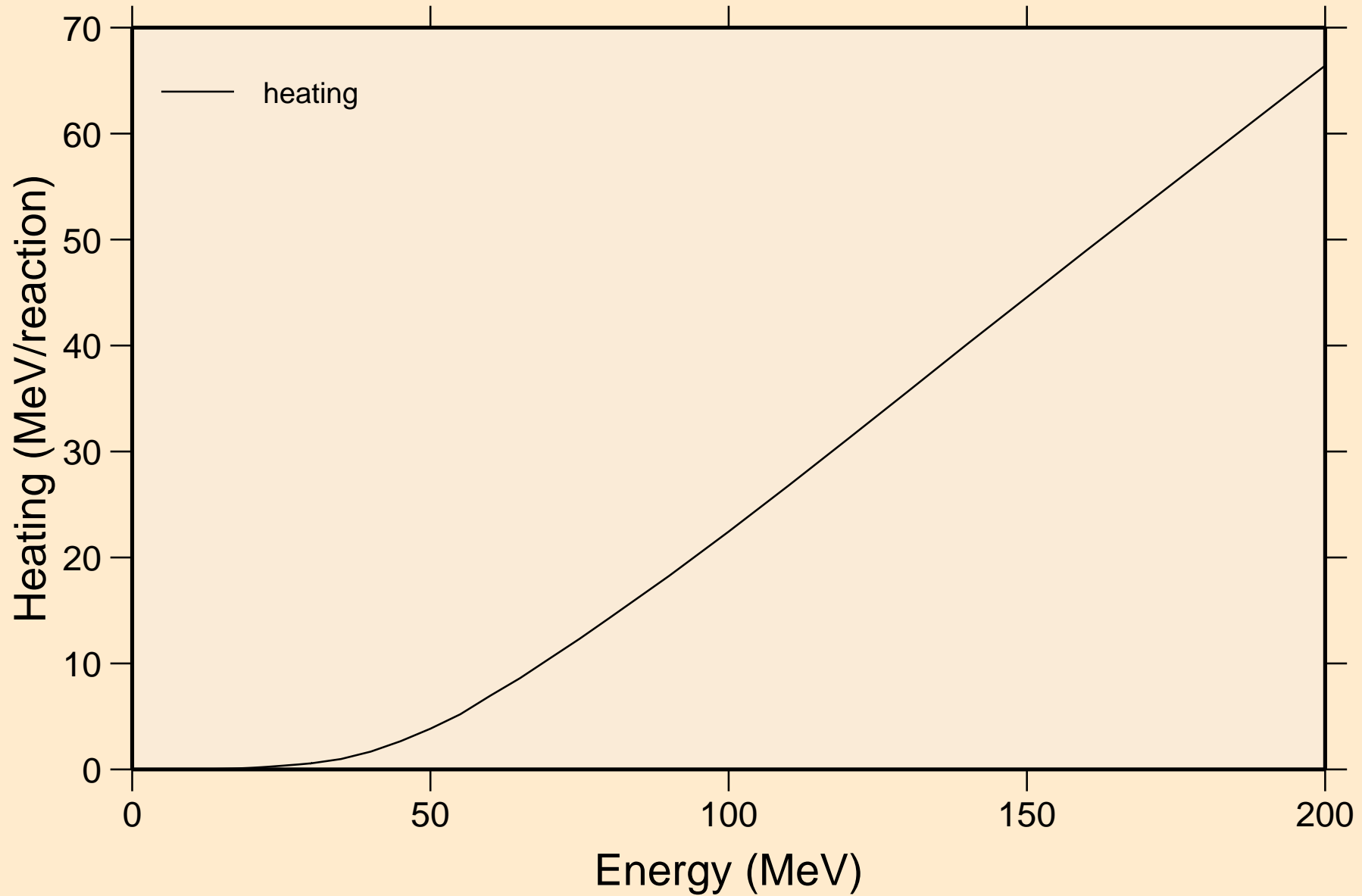

K042 ALPHA ACER TENDL-2024 LIBRARY; T=0.K  
Threshold reactions

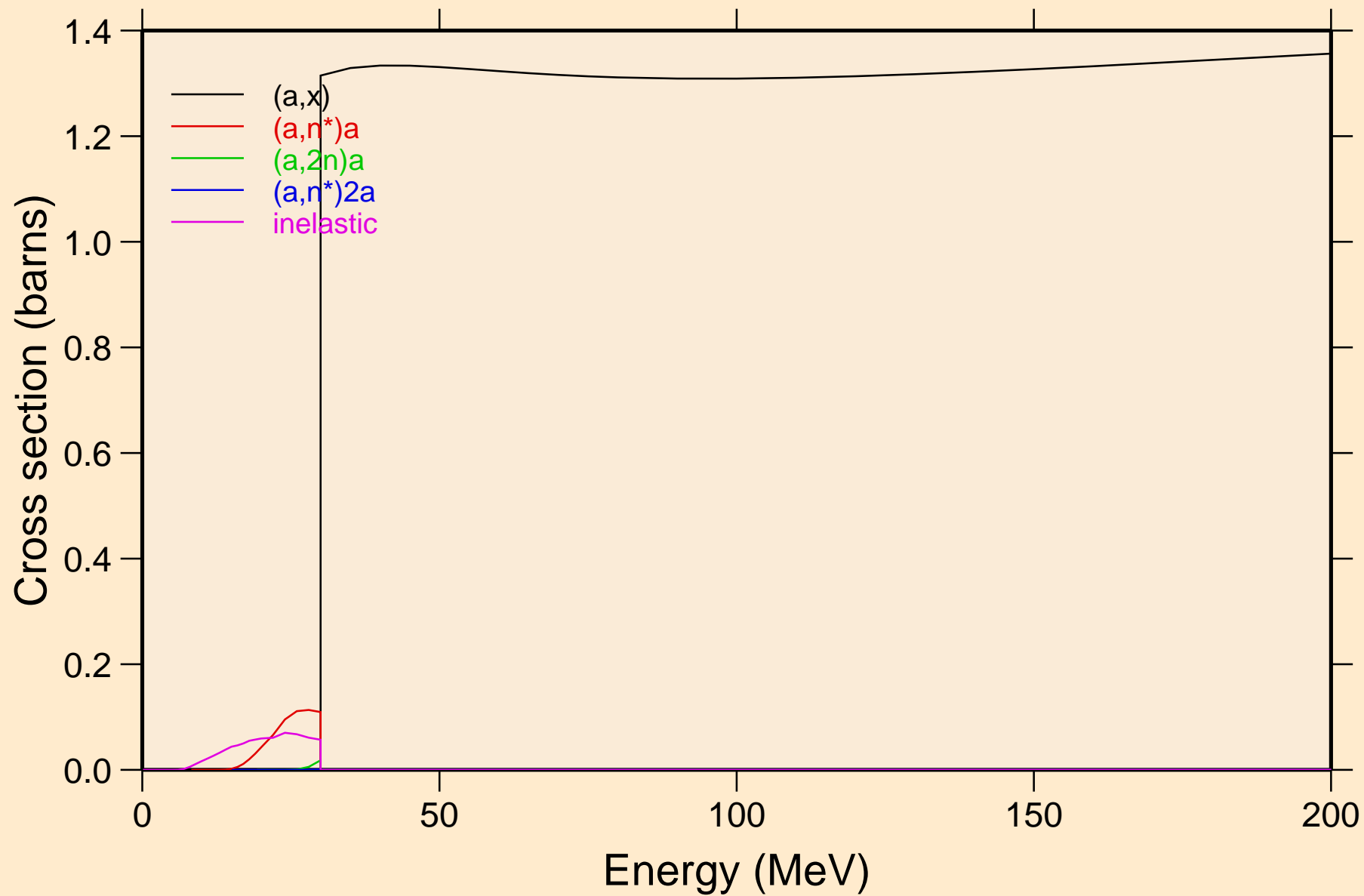

K042 ALPHA ACER TENDL-2024 LIBRARY; T=0.K  
Threshold reactions

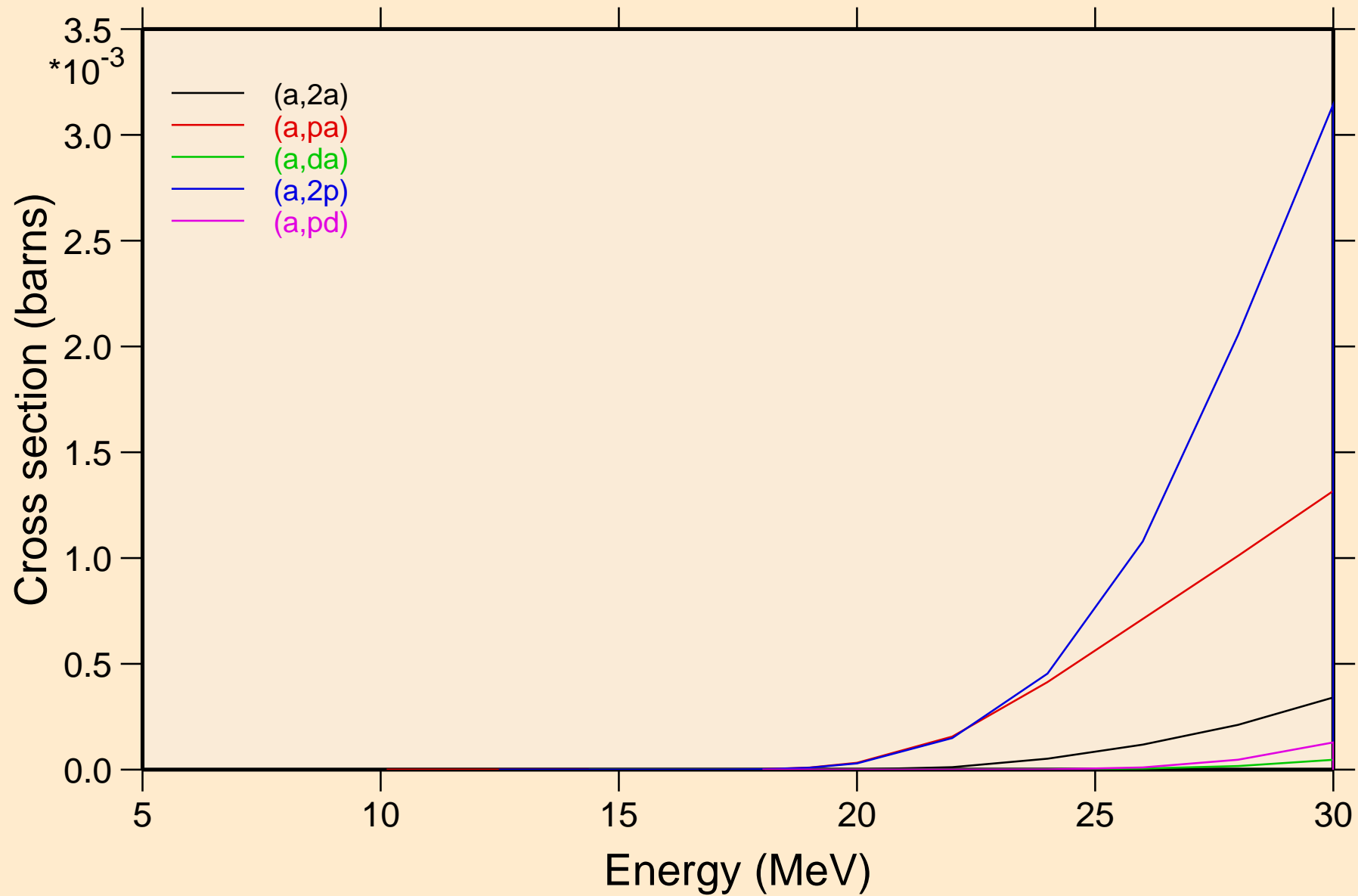

K042 ALPHA ACER TENDL-2024 LIBRARY; T=0.K  
Threshold reactions

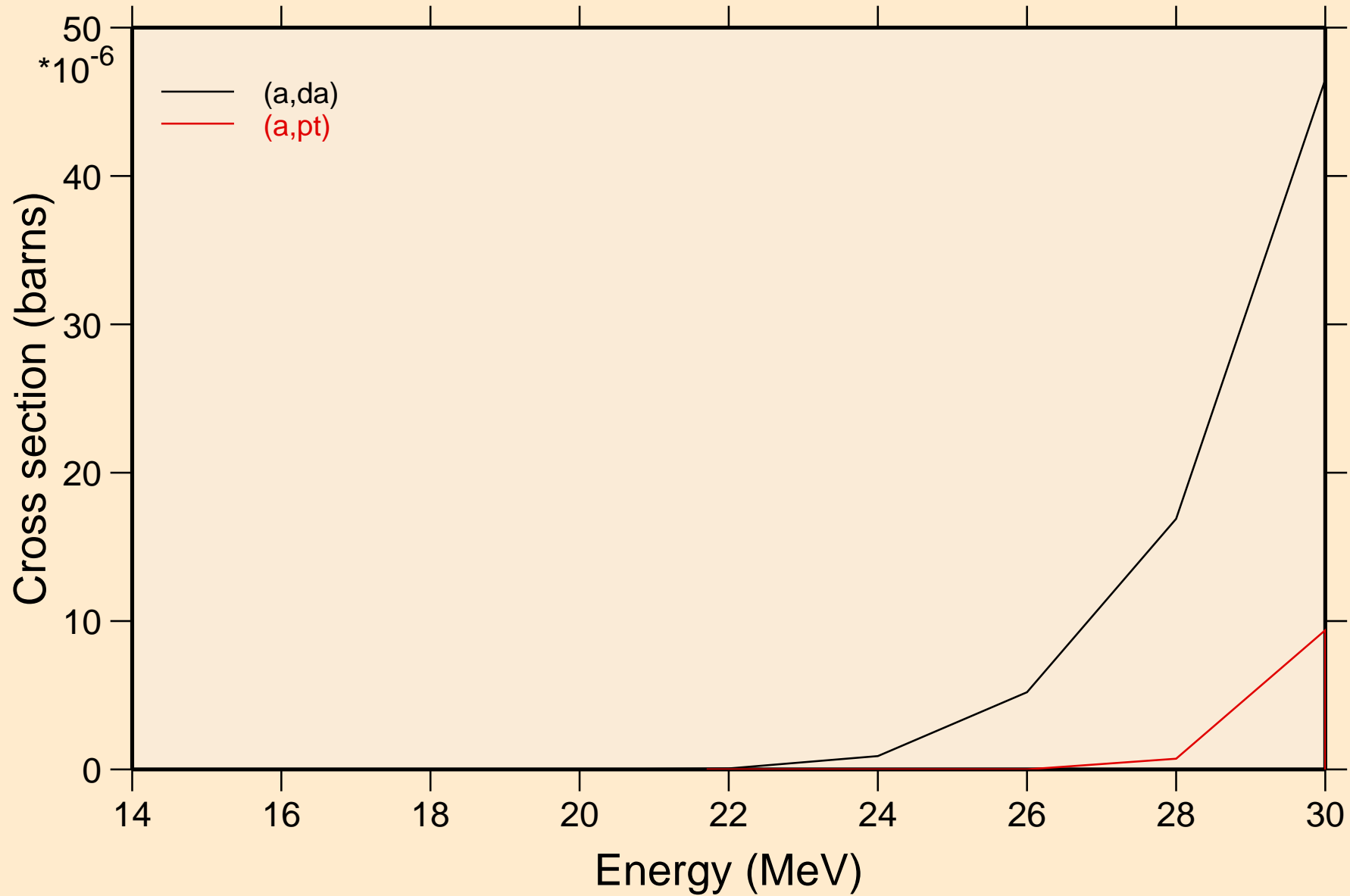

K042 ALPHA ACER TENDL-2024 LIBRARY; T=0.K  
Threshold reactions

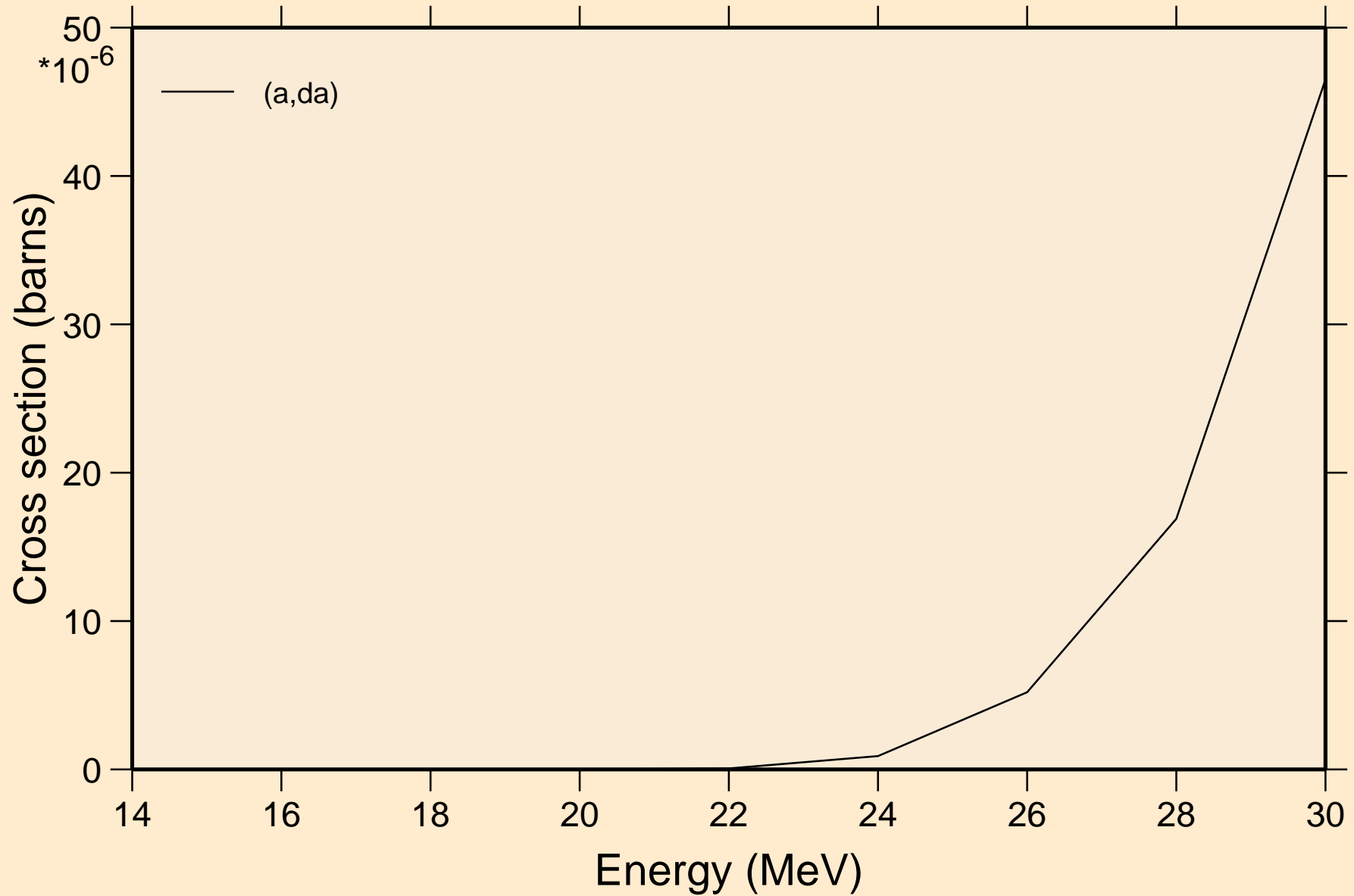

K042 ALPHA ACER TENDL-2024 LIBRARY; T=0.K  
angular distribution for elastic

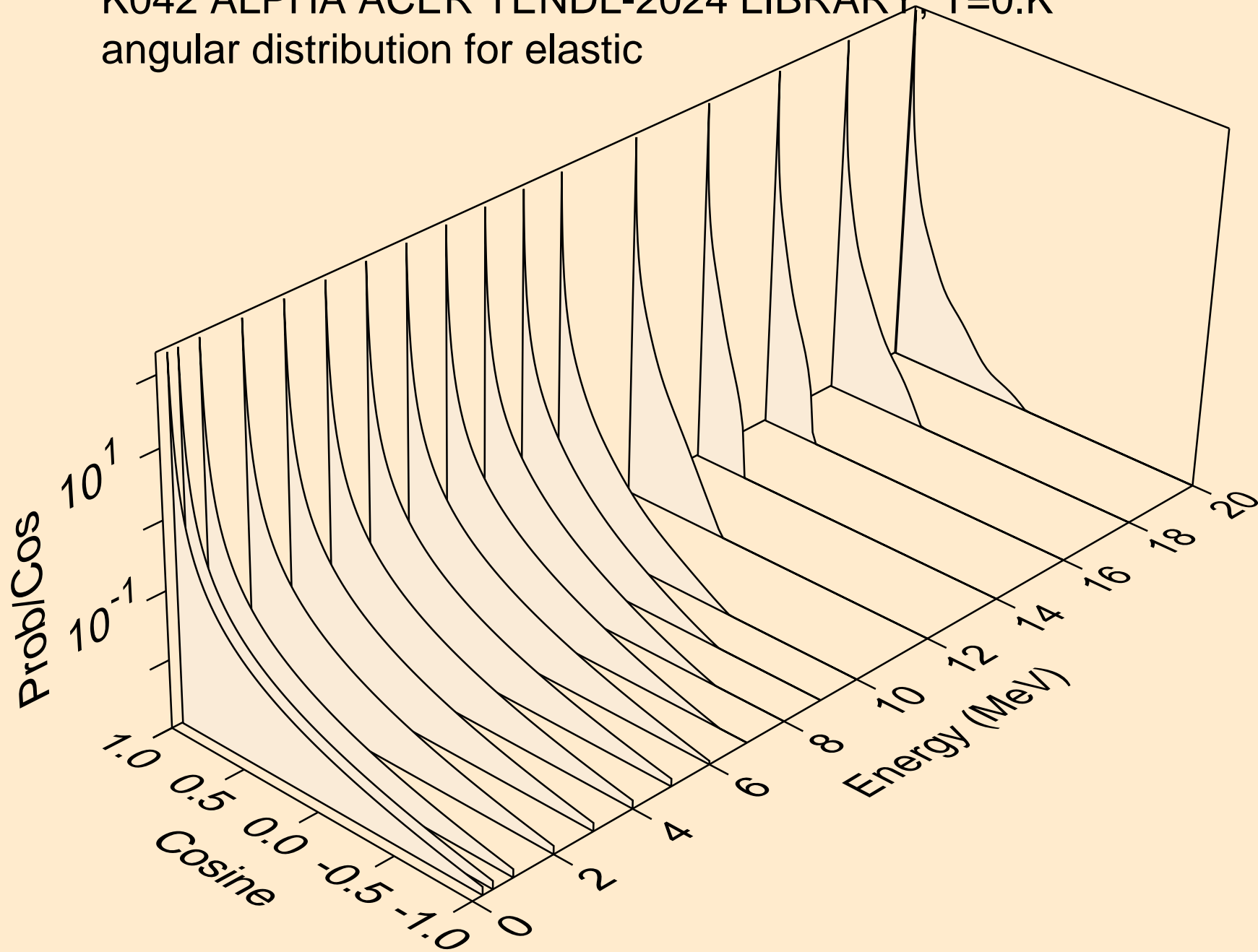

K042 ALPHA ACER TENDL-2024 LIBRARY: T=0.K  
angular distribution for elastic

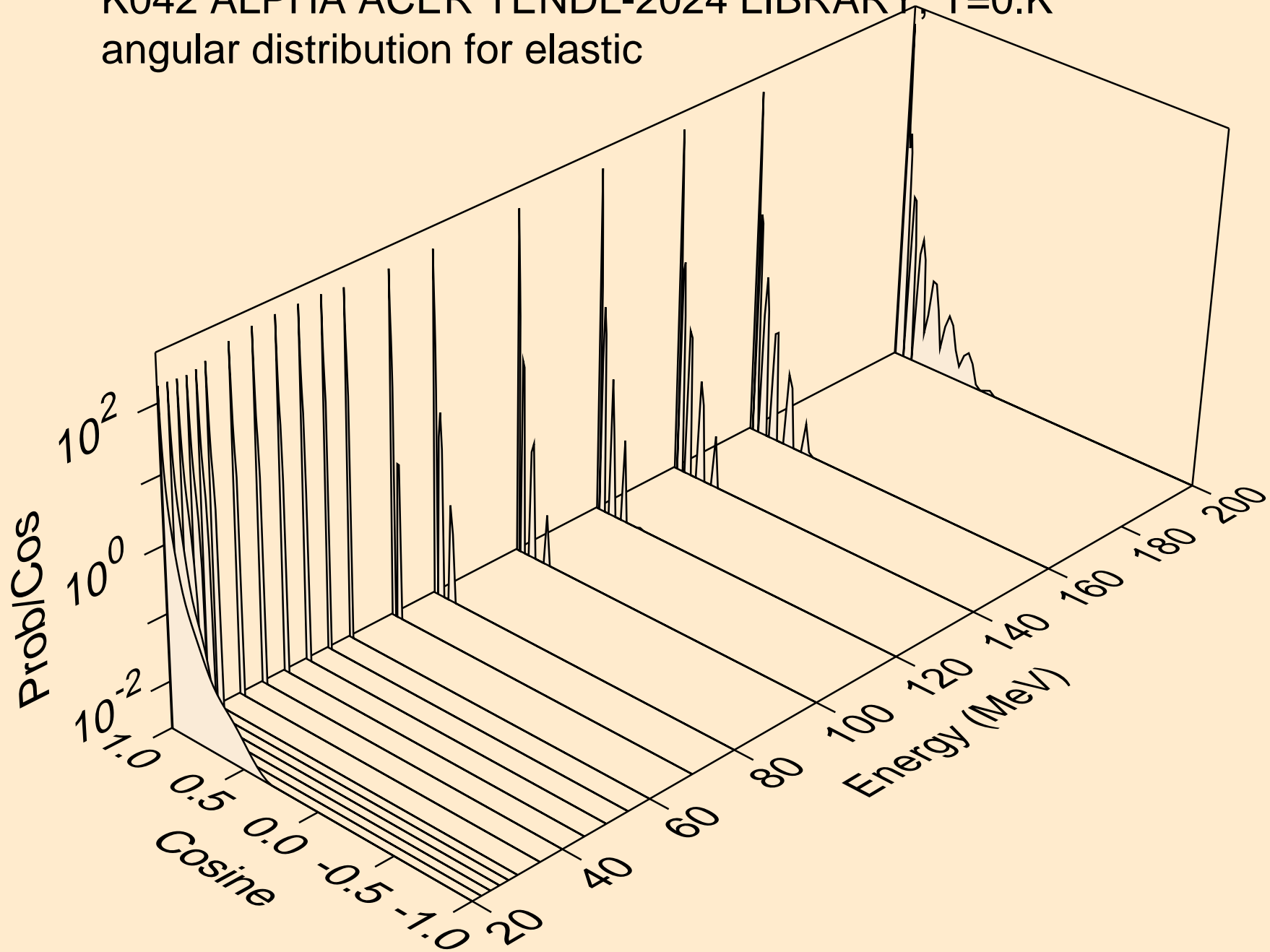

K042 ALPHA ACER TENDL-2024 LIBRARY; T=0.K  
Alpha emission for (a,x)

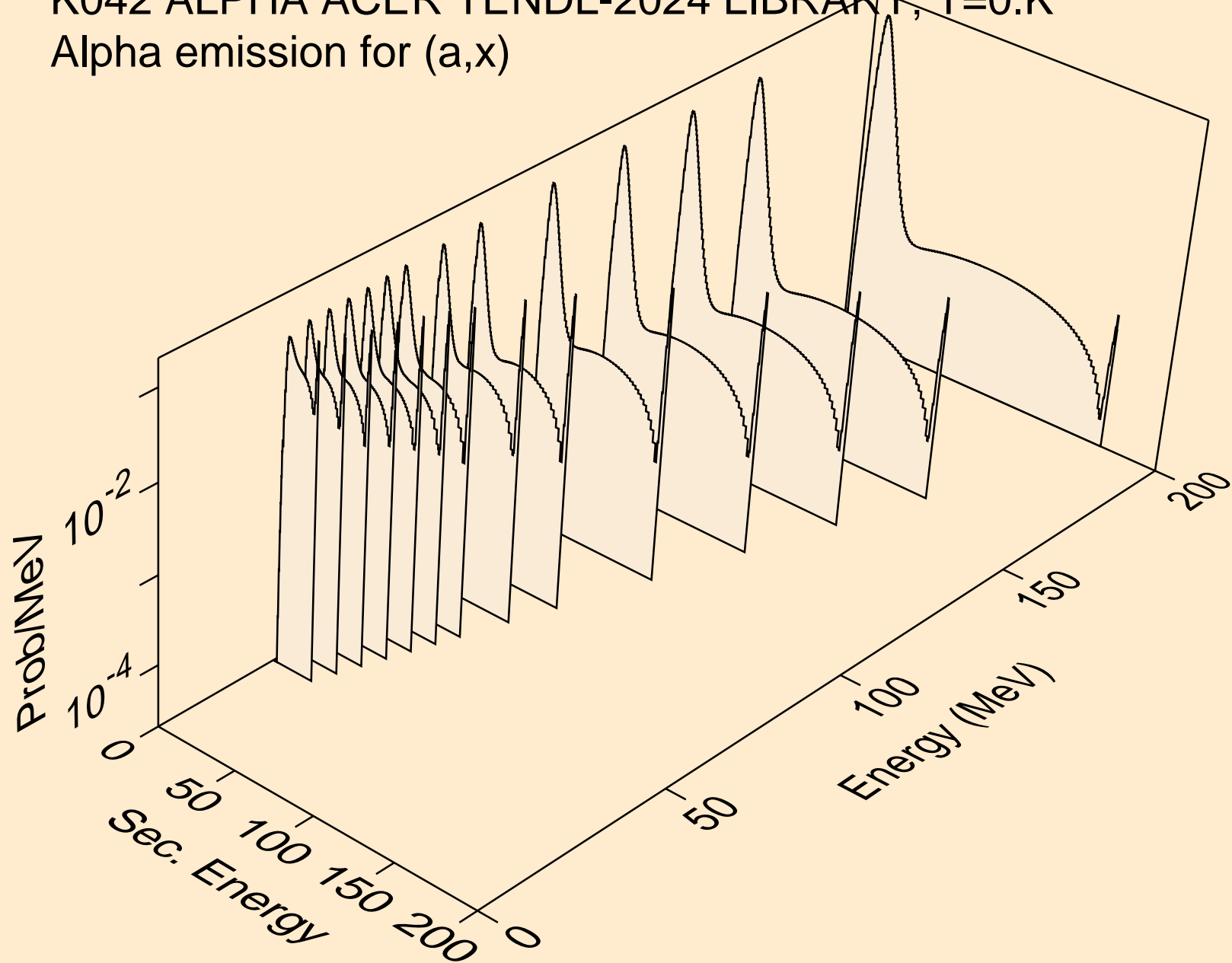

K042 ALPHA ACER TENDL-2024 LIBRARY; T=0.K  
Alpha emission for (a,n\*)a

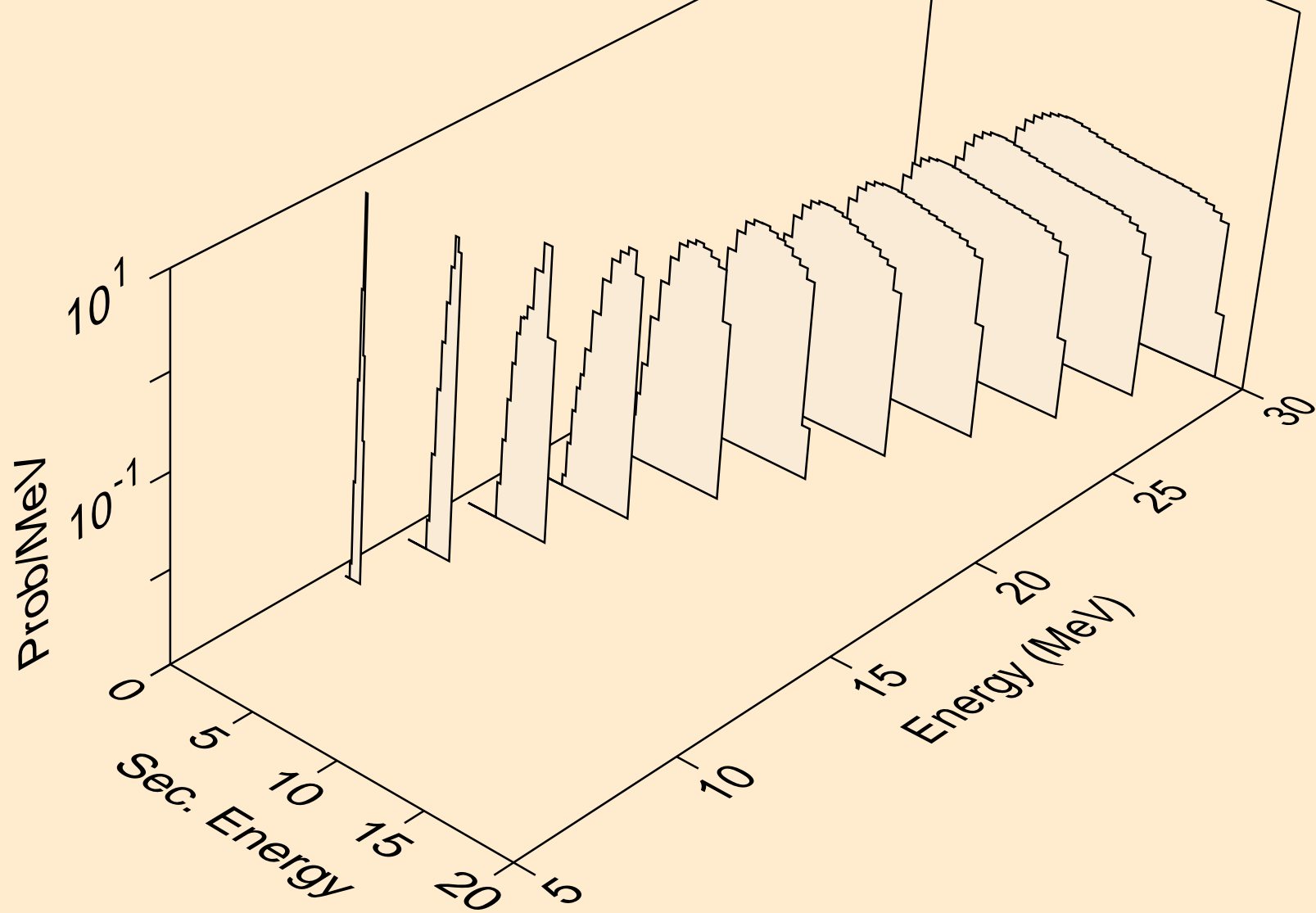

K042 ALPHA ACER TENDL-2024 LIBRARY; T=0.K  
Alpha emission for (a,2n)a

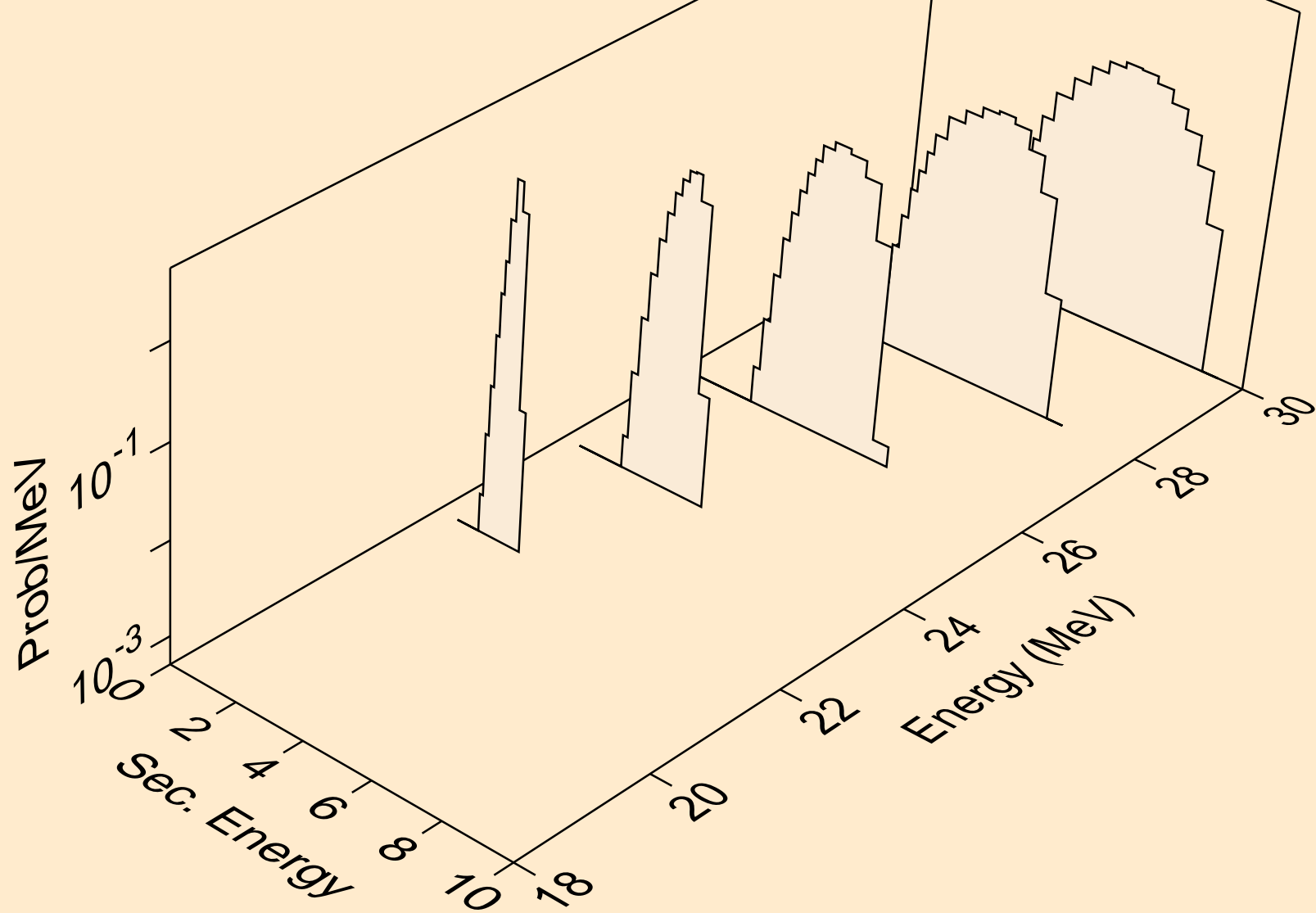

K042 ALPHA ACER TENDL-2024 LIBRARY; T=0.K

Alpha emission for (a,n\*)2a

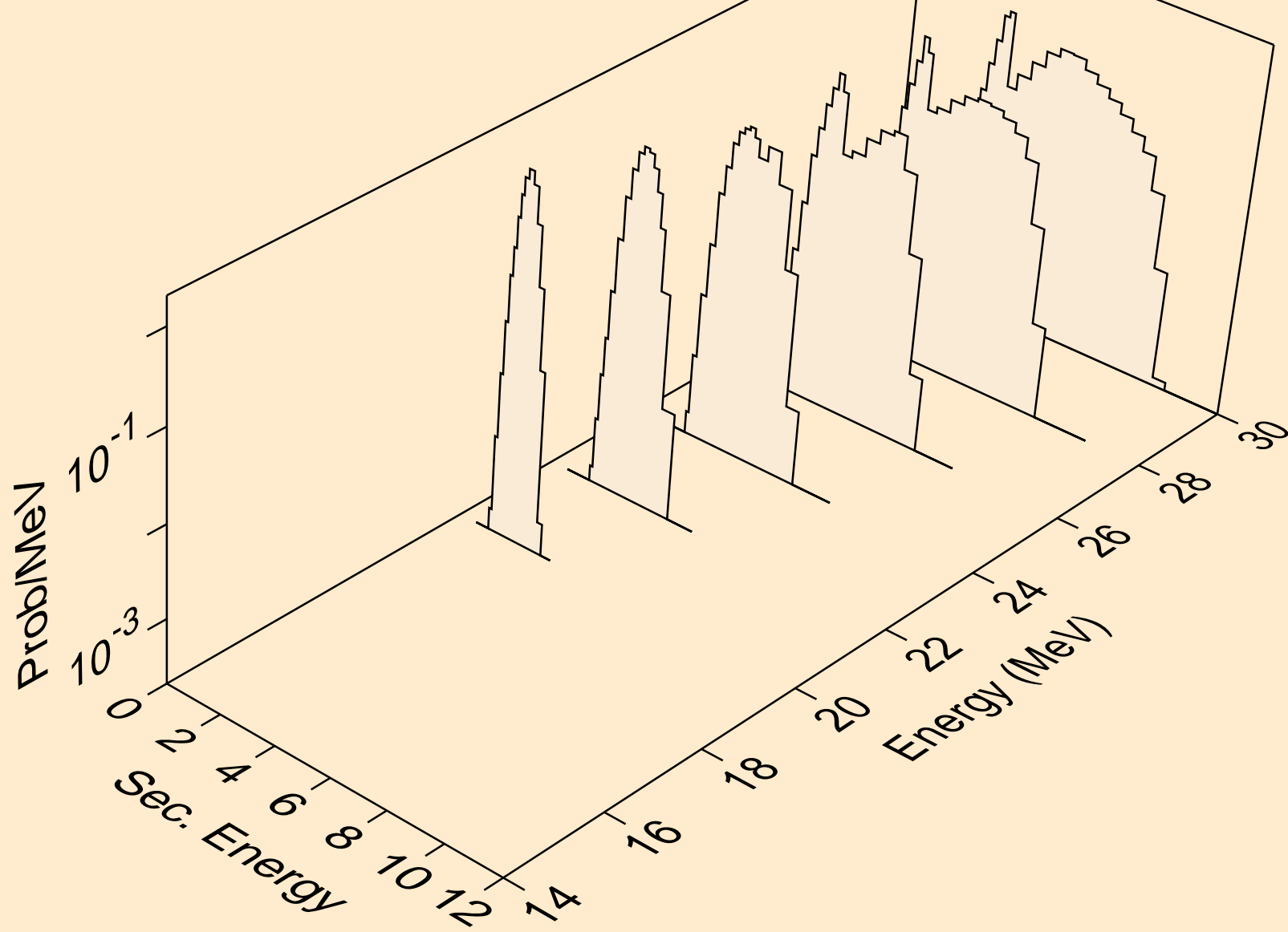

K042 ALPHA ACER TENDL-2024 LIBRARY; T=0.K  
Alpha emission for inelastic

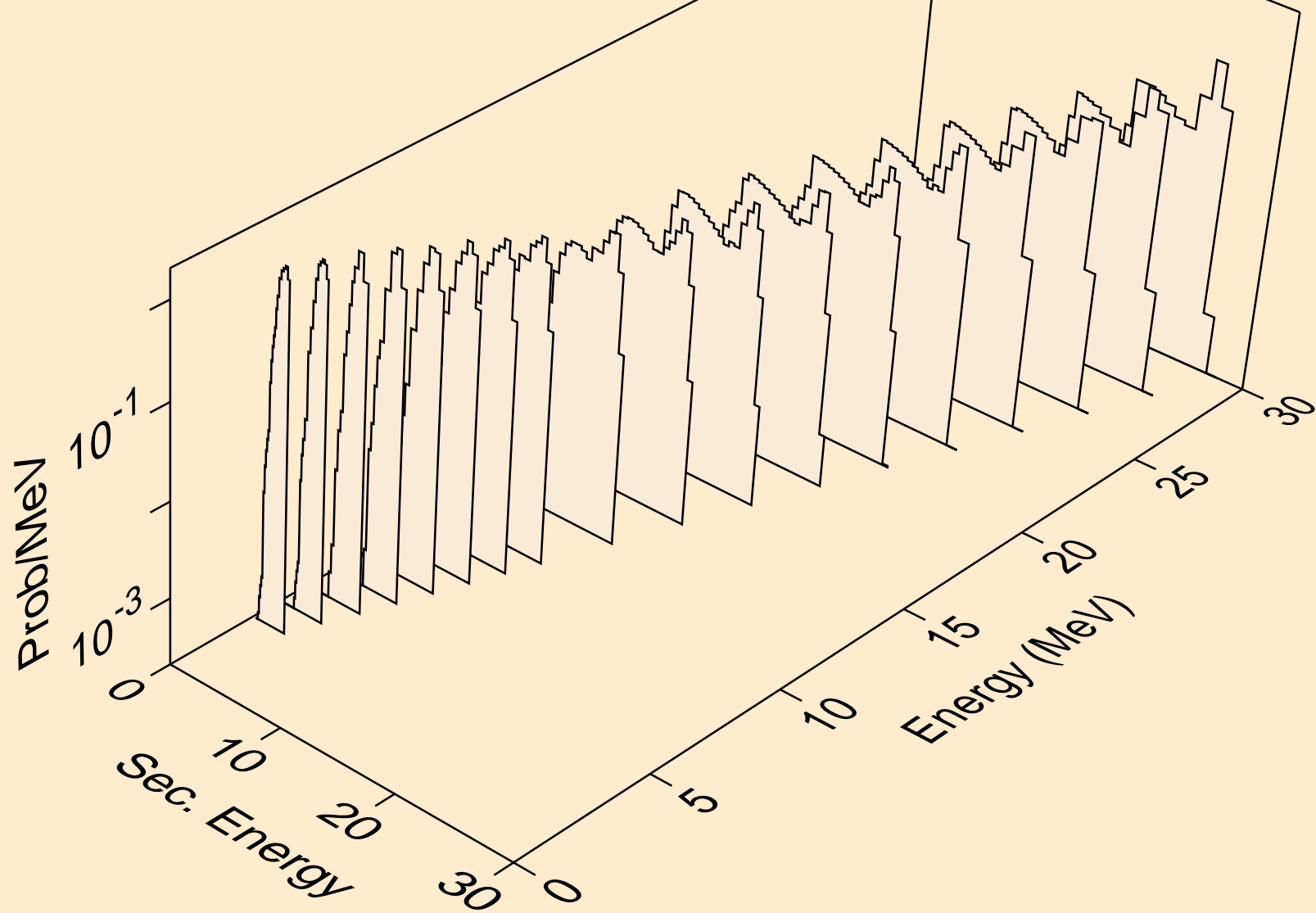

K042 ALPHA ACER TENDL-2024 LIBRARY; T=0.K  
Alpha emission for (a,2a)

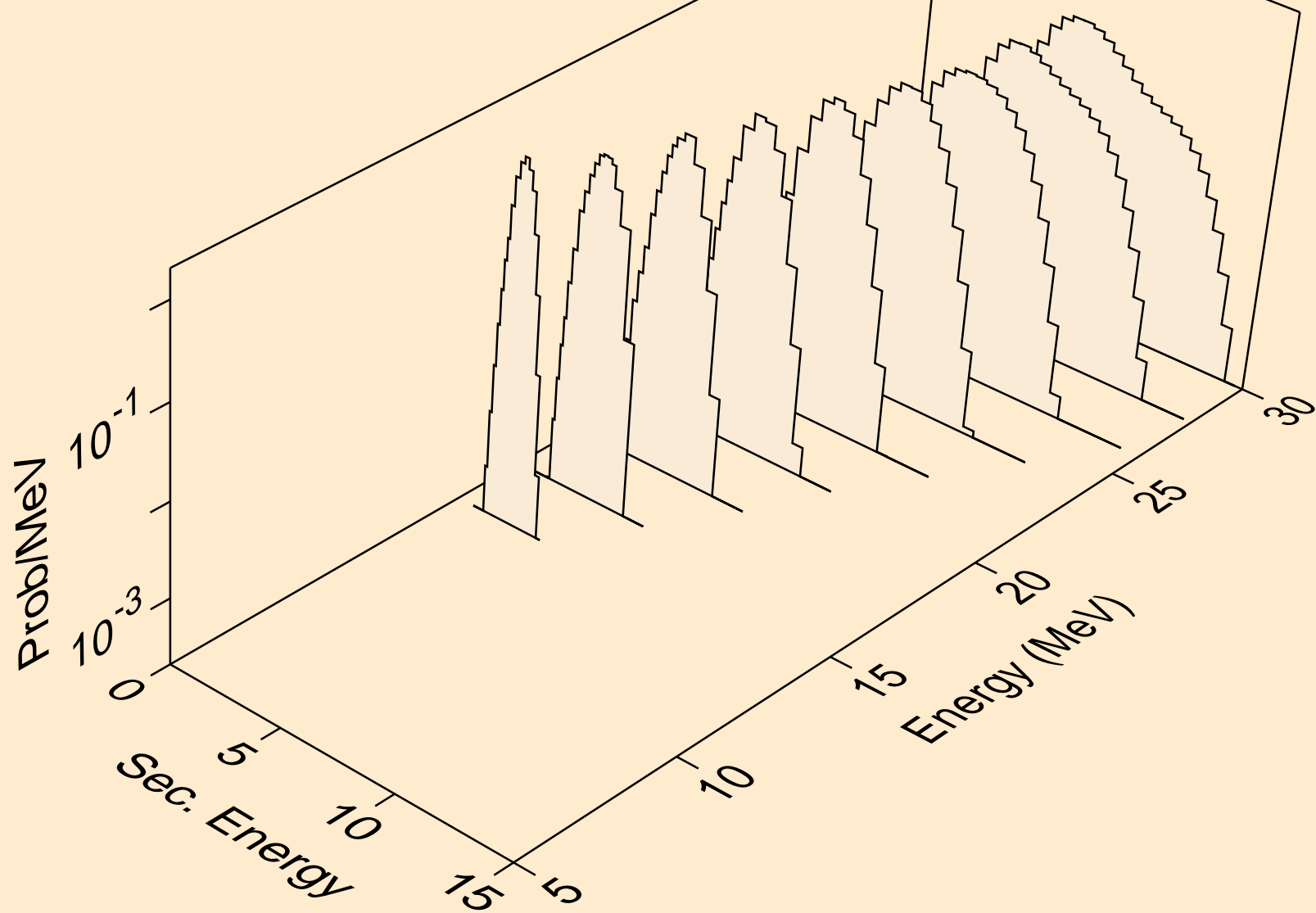

K042 ALPHA ACER TENDL-2024 LIBRARY; T=0.K  
Alpha emission for (a,pa)

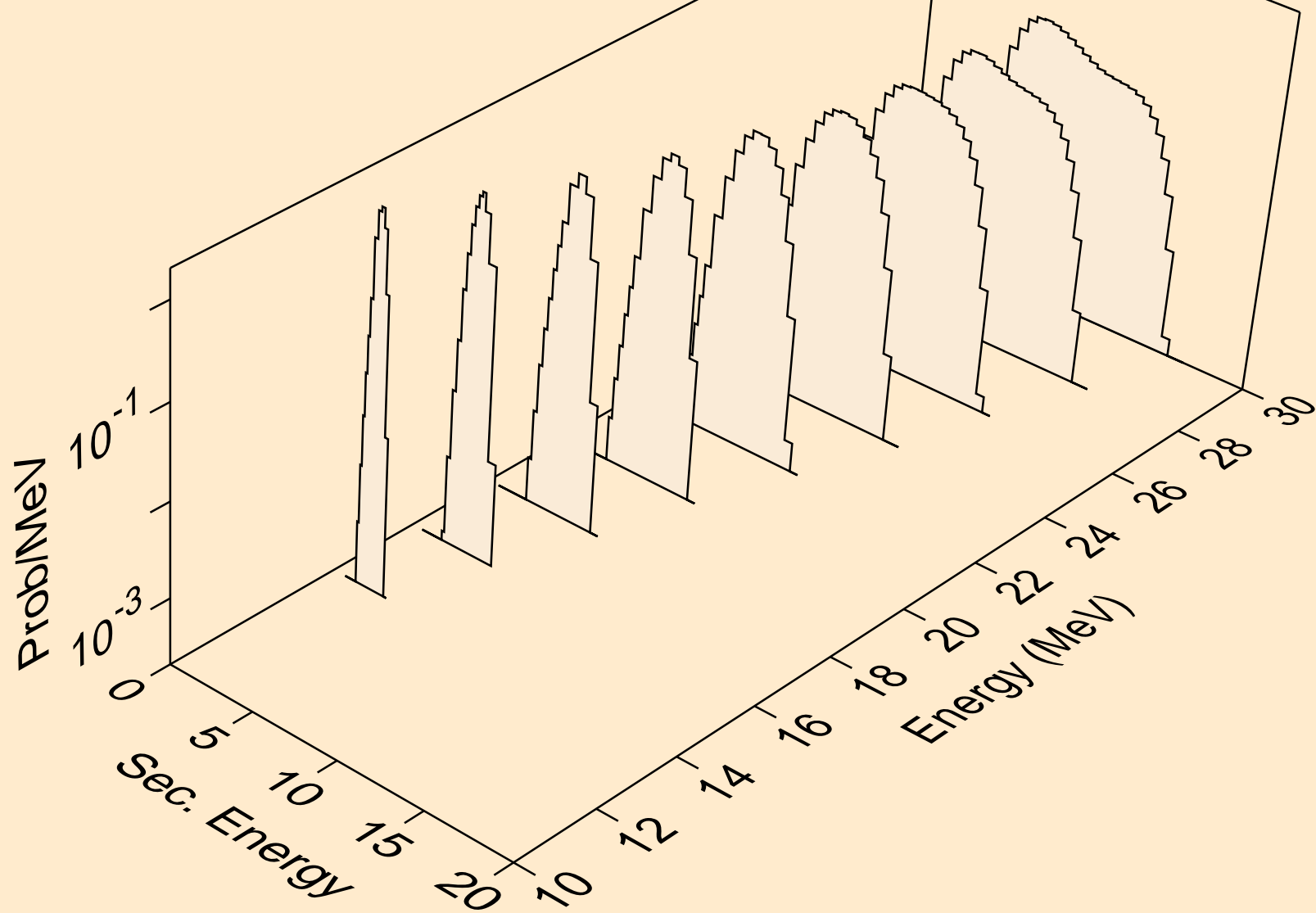

K042 ALPHA ACER TENDL-2024 LIBRARY; T=0.K  
Alpha emission for (a,da)

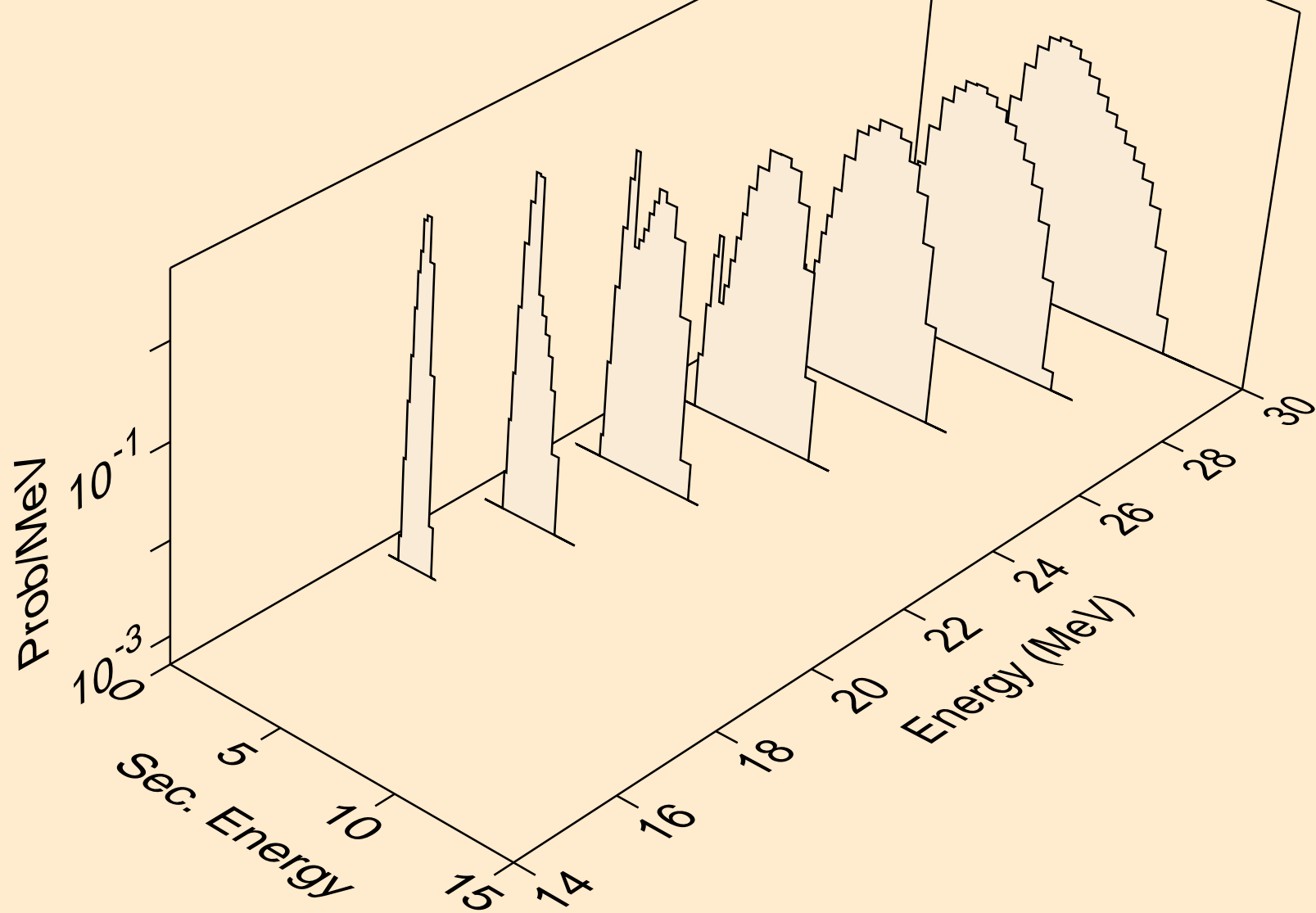

K042 ALPHA ACER TENDL-2024 LIBRARY; T=0.K  
Photon emission for (z,n)

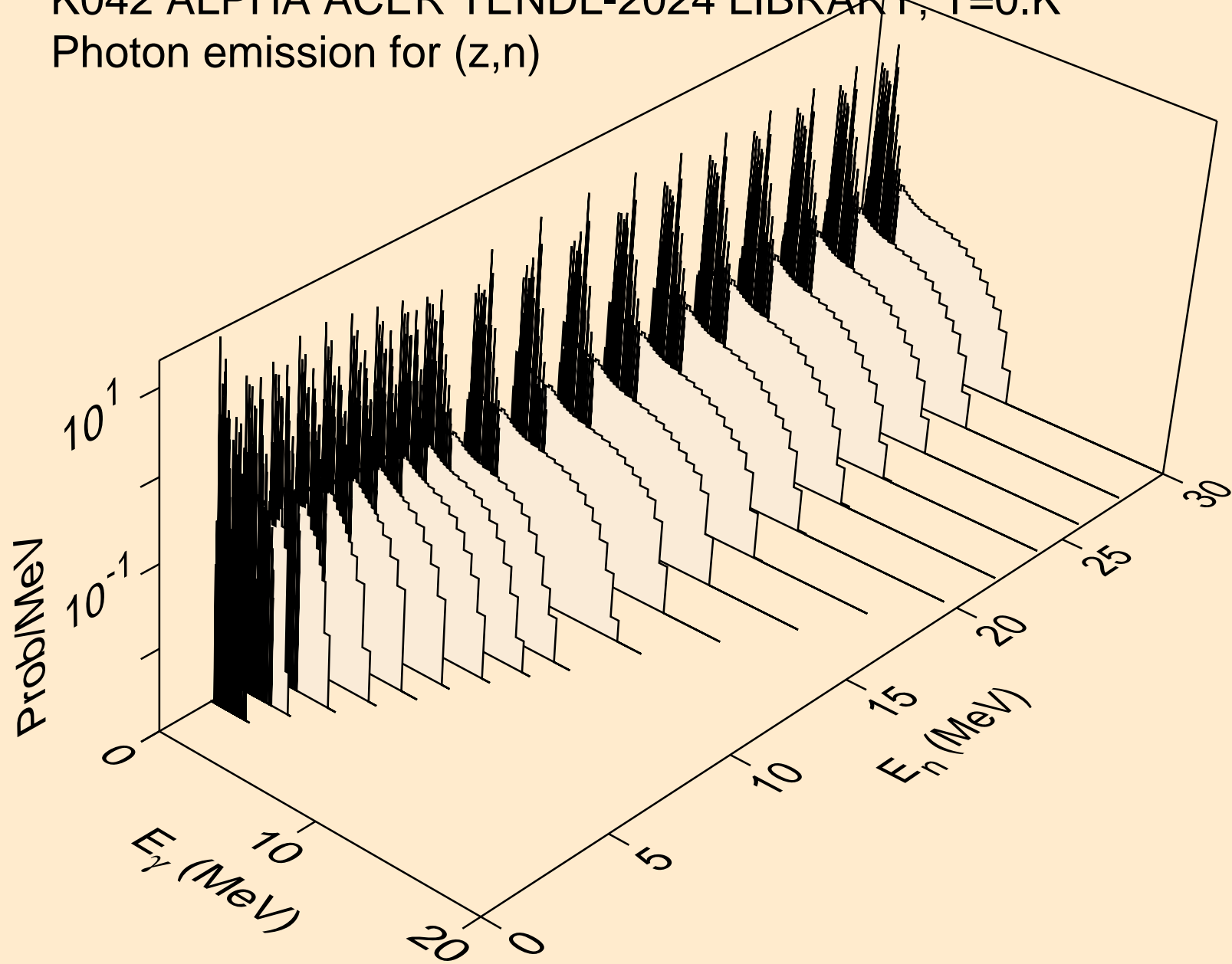

K042 ALPHA ACER TENDL-2024 LIBRARY; T=0.K  
Photon emission for (z,x)

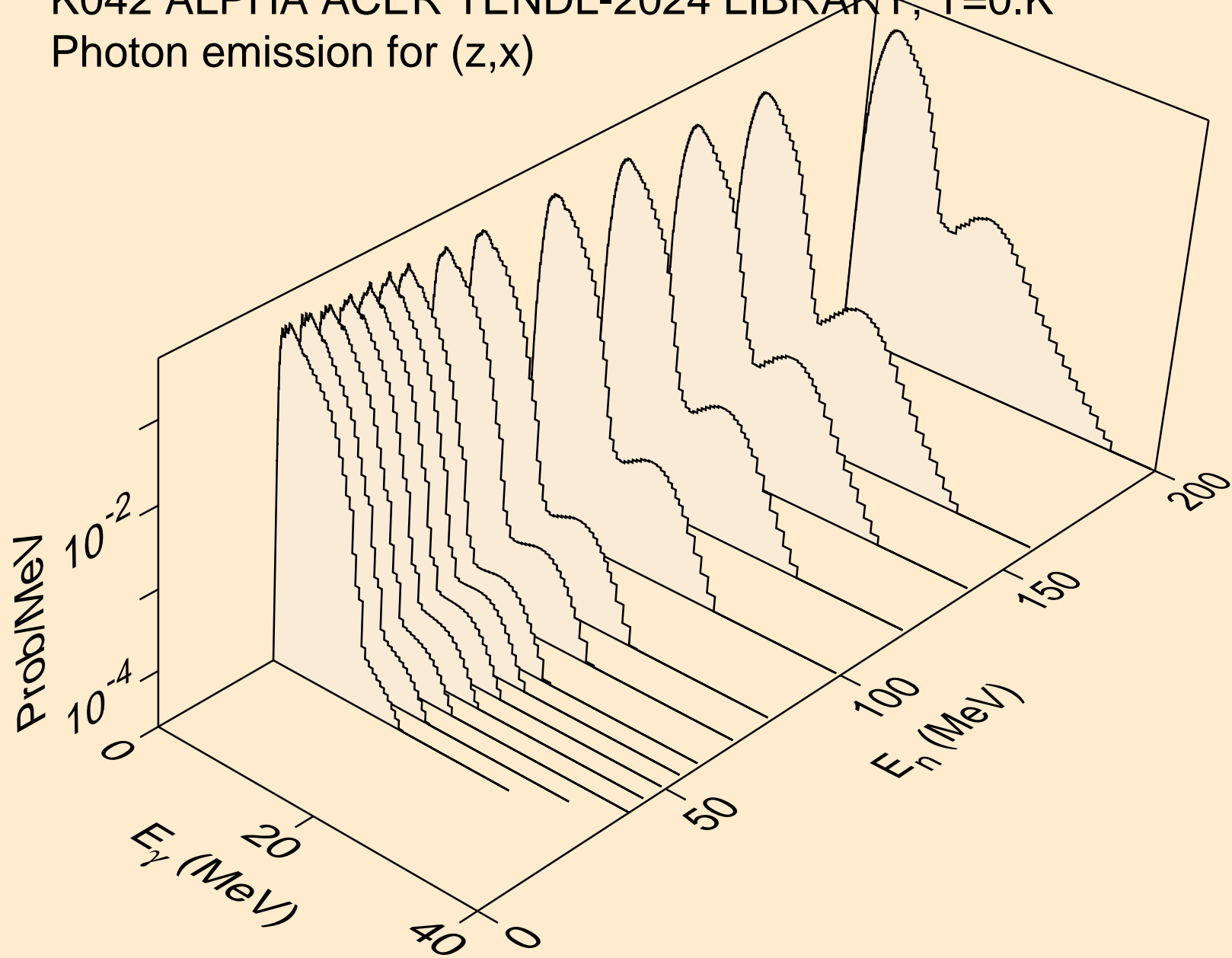

K042 ALPHA ACER TENDL-2024 LIBRARY; T=0.K  
Photon emission for (n,2nd)

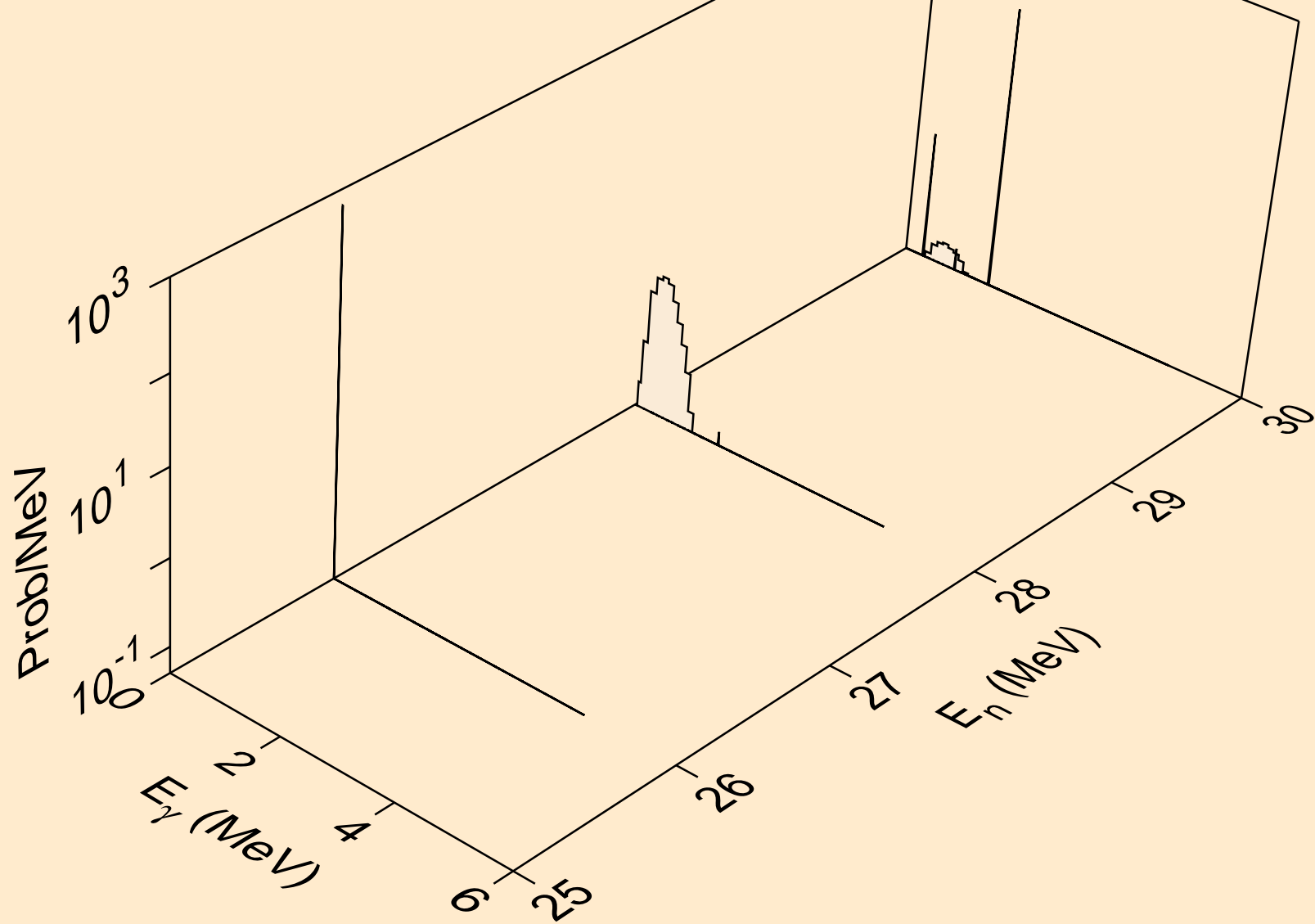

K042 ALPHA ACER TENDL-2024 LIBRARY; T=0.K  
Photon emission for (n,2n)

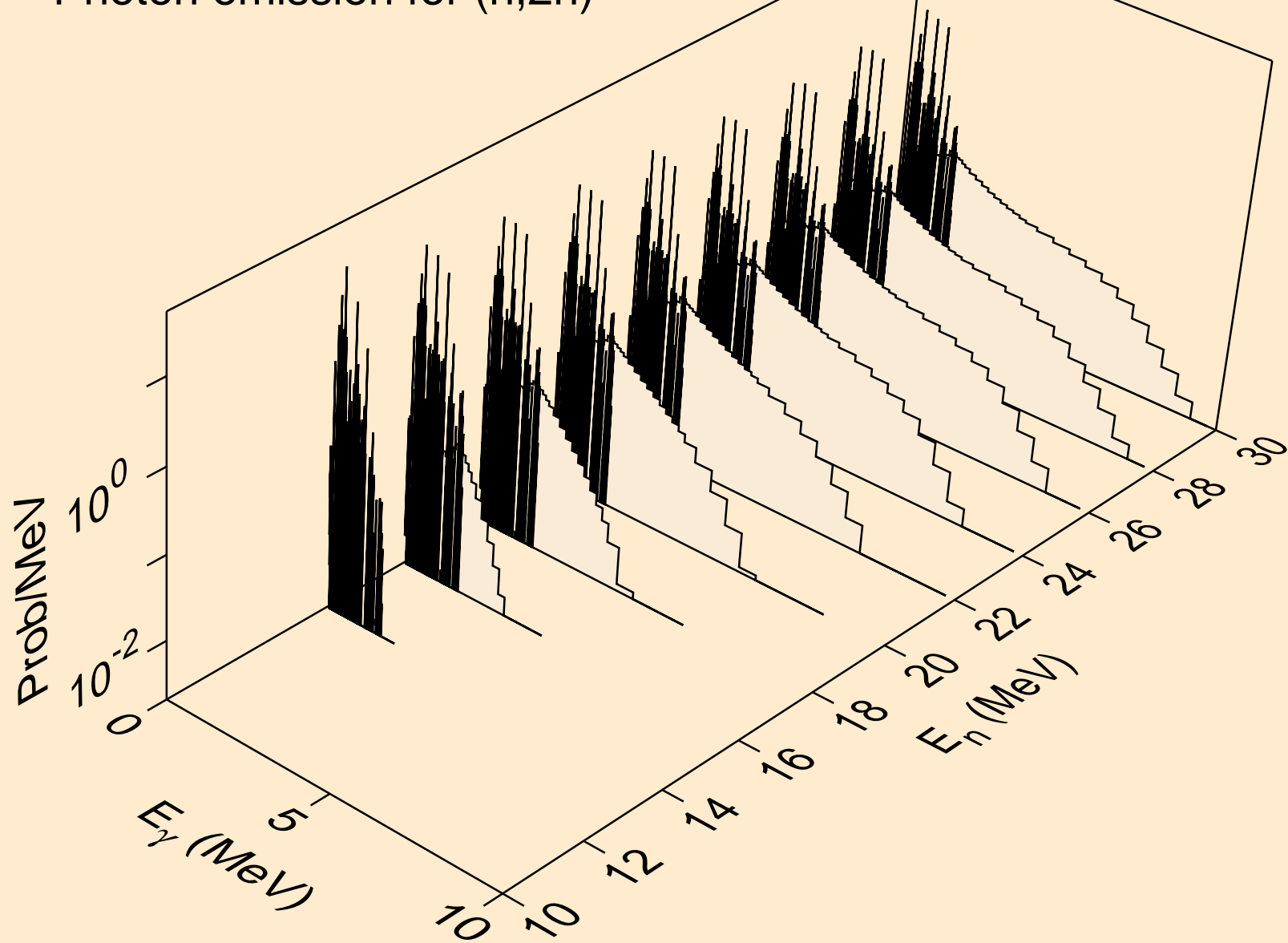

K042 ALPHA ACER TENDL-2024 LIBRARY; T=0.K  
Photon emission for (n,3n)

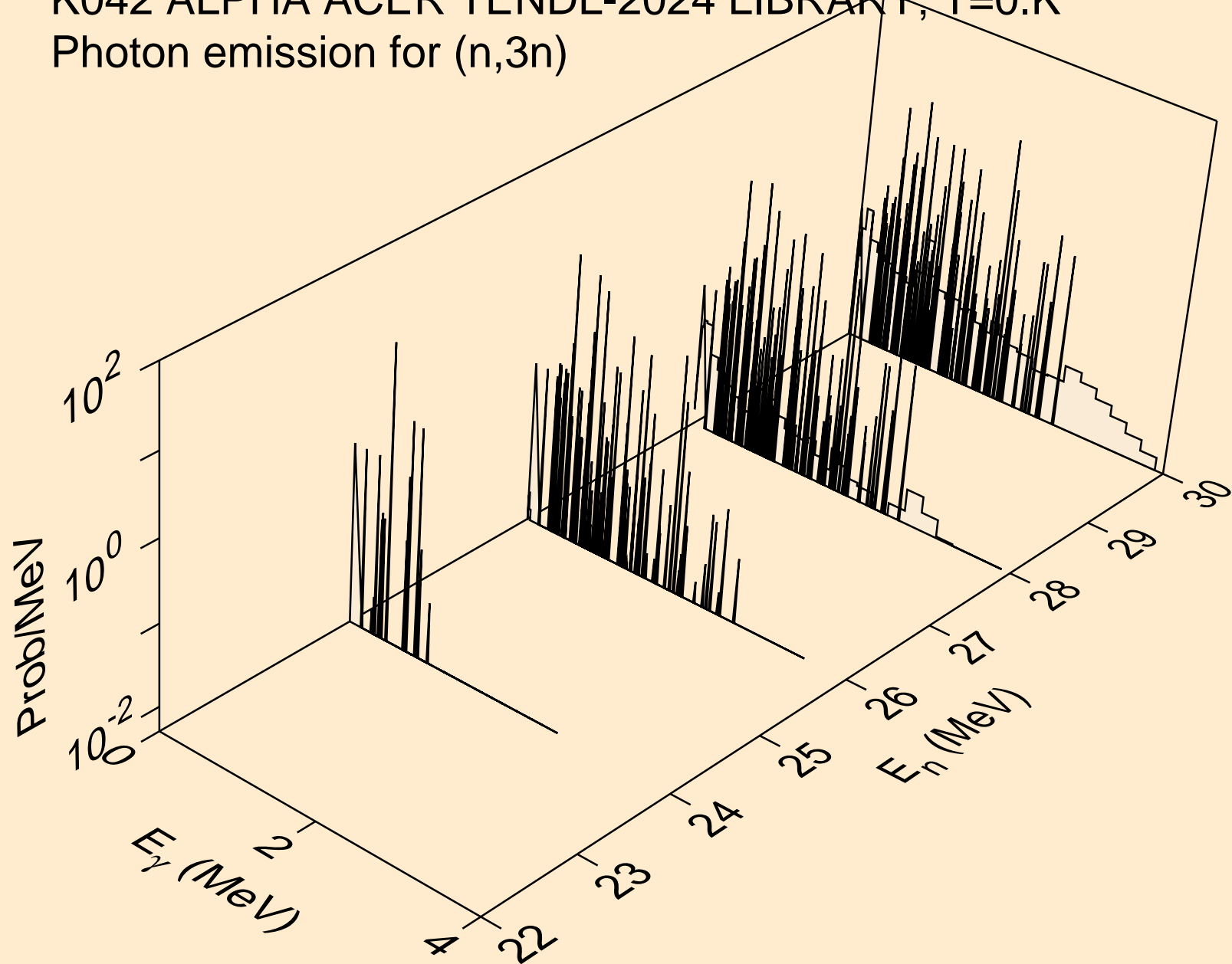

K042 ALPHA ACER TENDL-2024 LIBRARY; T=0.K  
Photon emission for (n,n\*)a

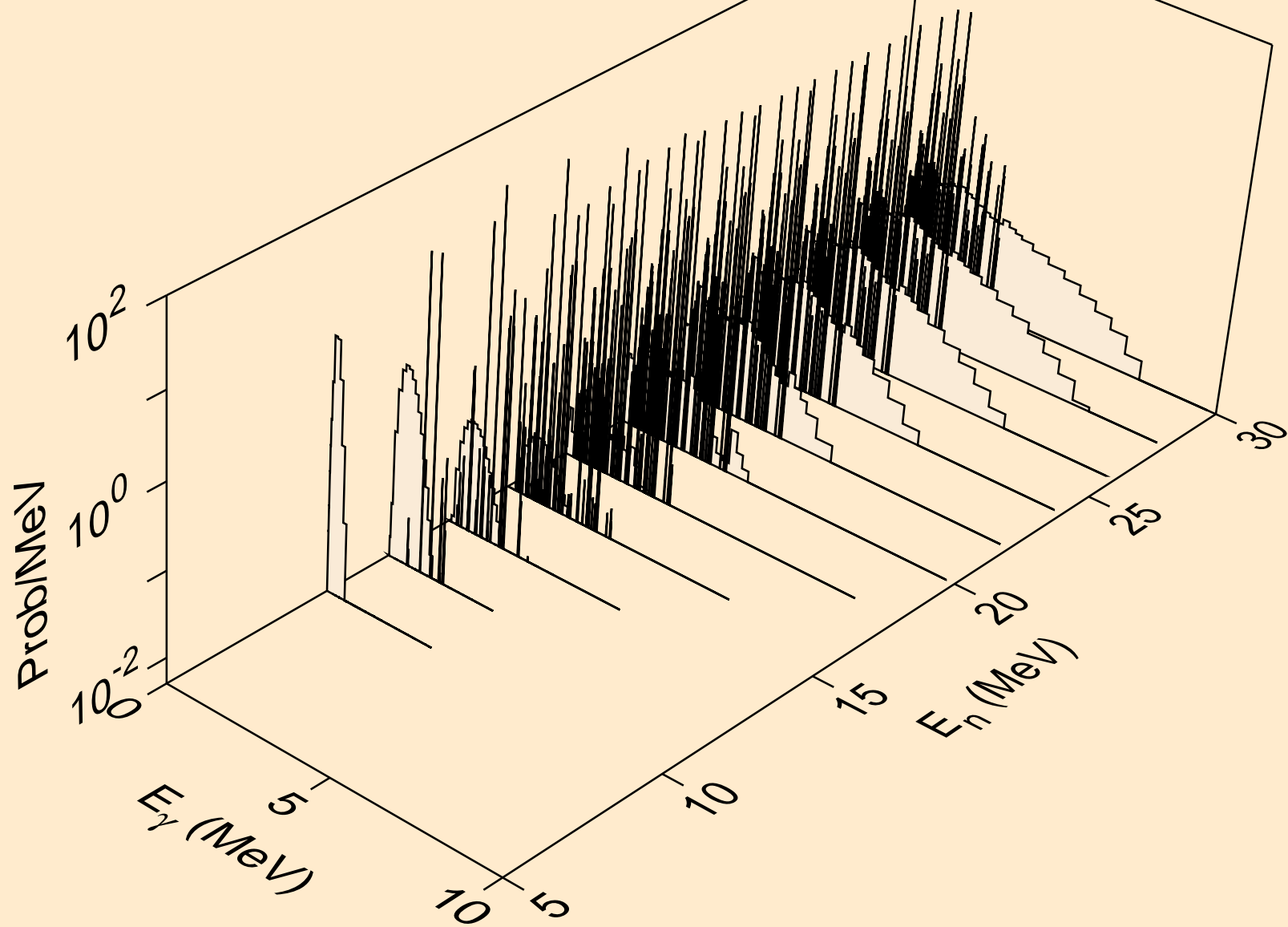

K042 ALPHA ACER TENDL-2024 LIBRARY; T=0.K  
Photon emission for (n,2n)a

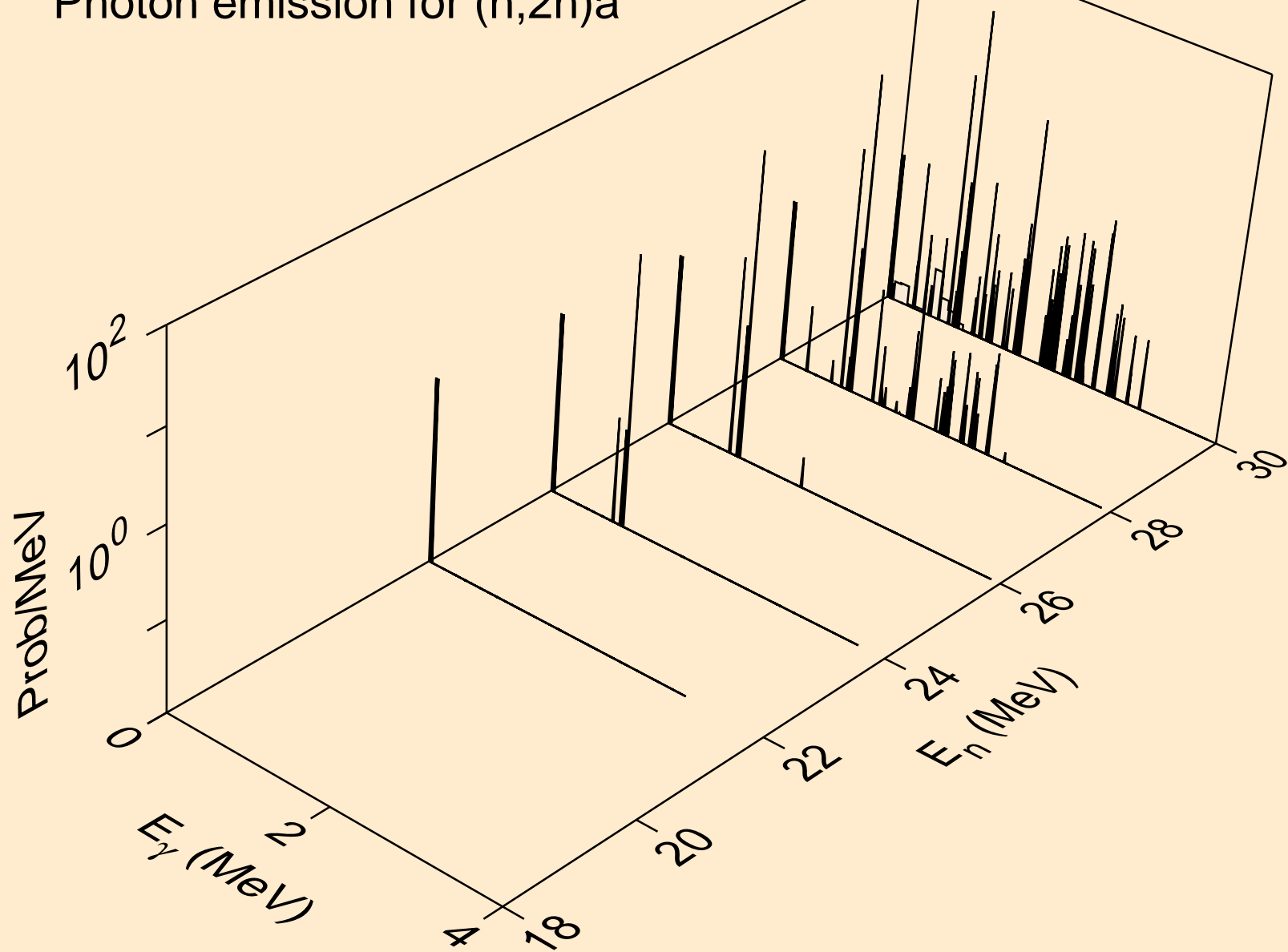

K042 ALPHA ACER TENDL-2024 LIBRARY; T=0.K  
Photon emission for (n,n\*)p

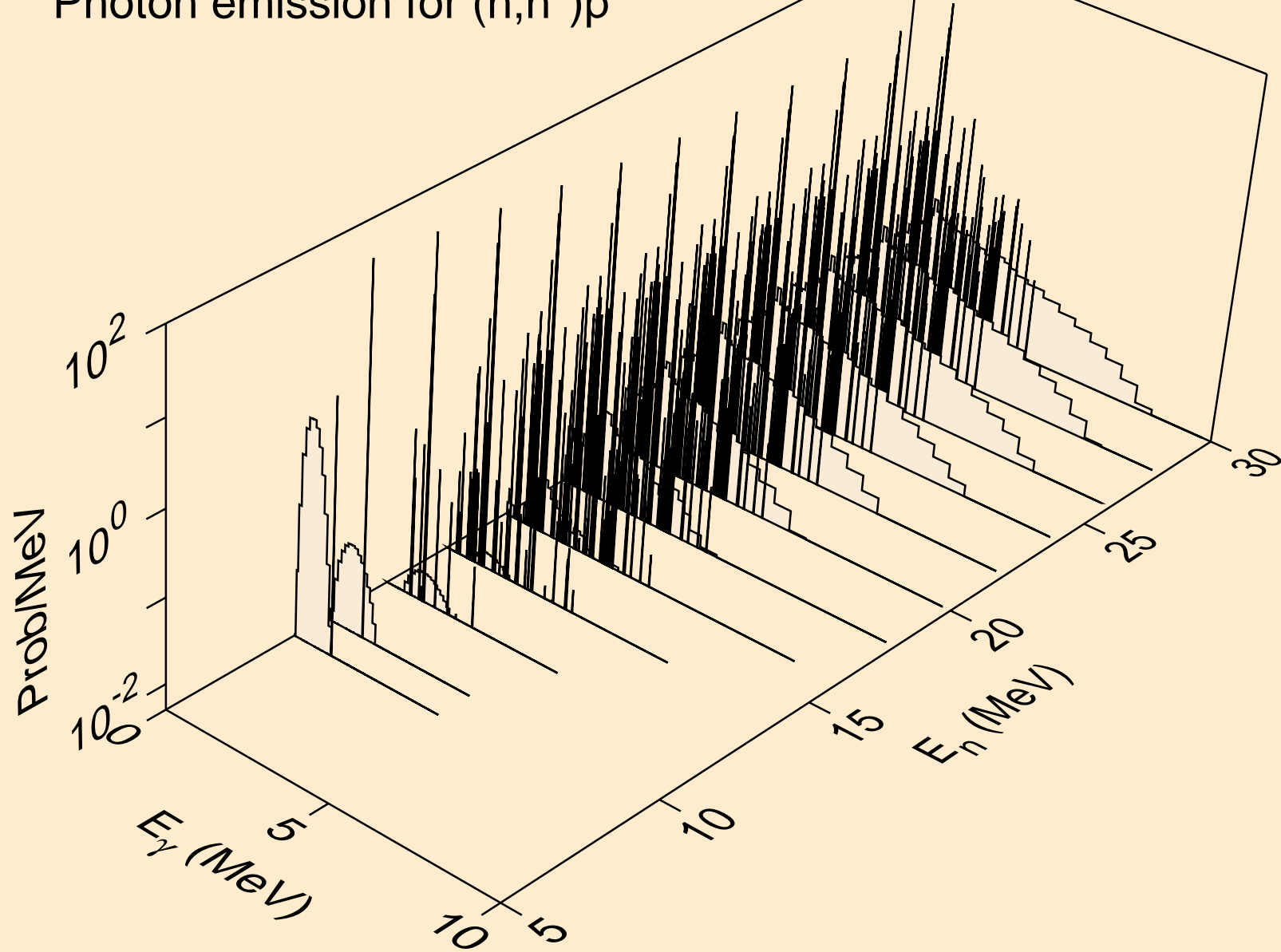

K042 ALPHA ACER TENDL-2024 LIBRARY; T=0.K  
Photon emission for (n,n\*)2a

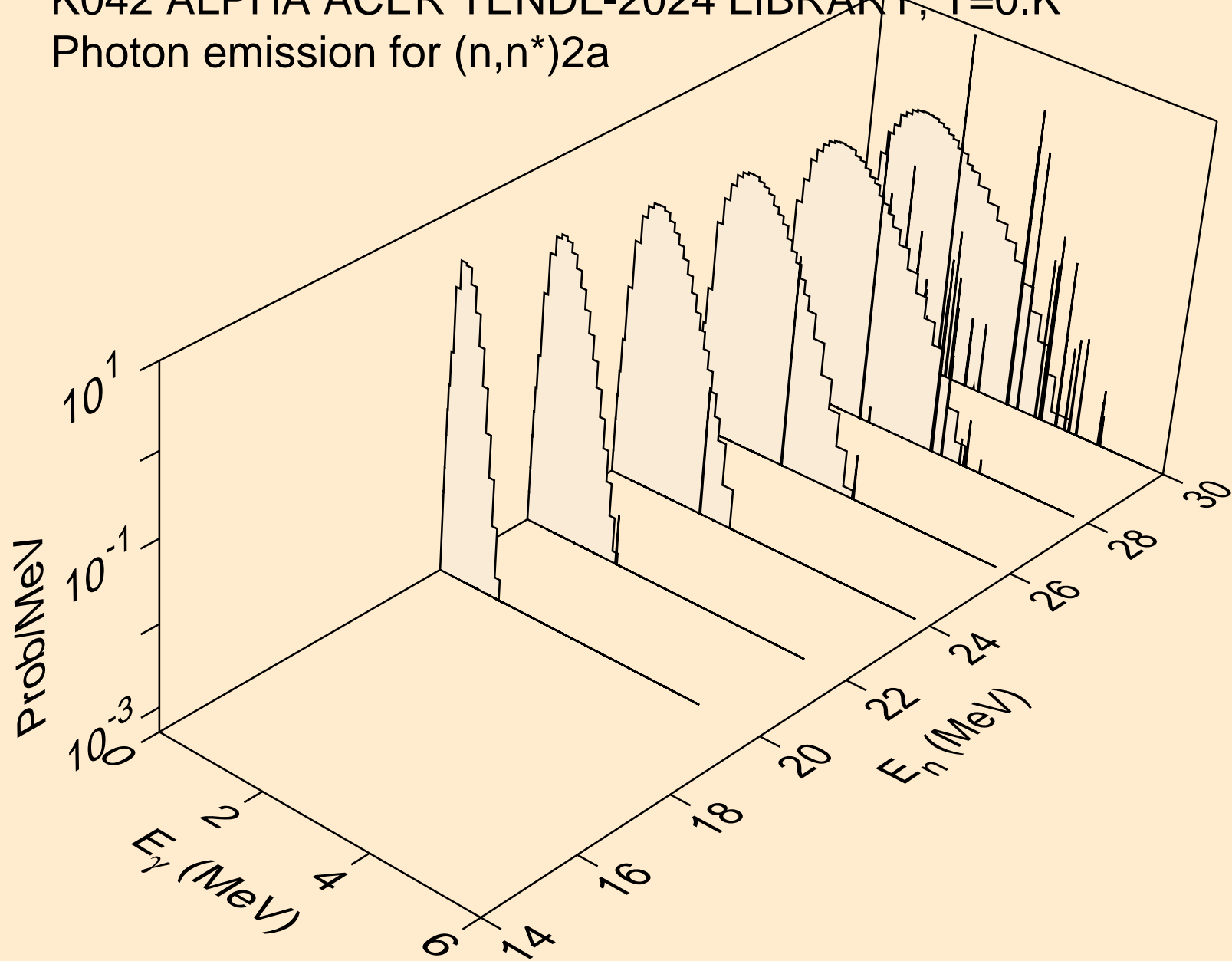

K042 ALPHA ACER TENDL-2024 LIBRARY; T=0.K  
Photon emission for (n,n\*)d

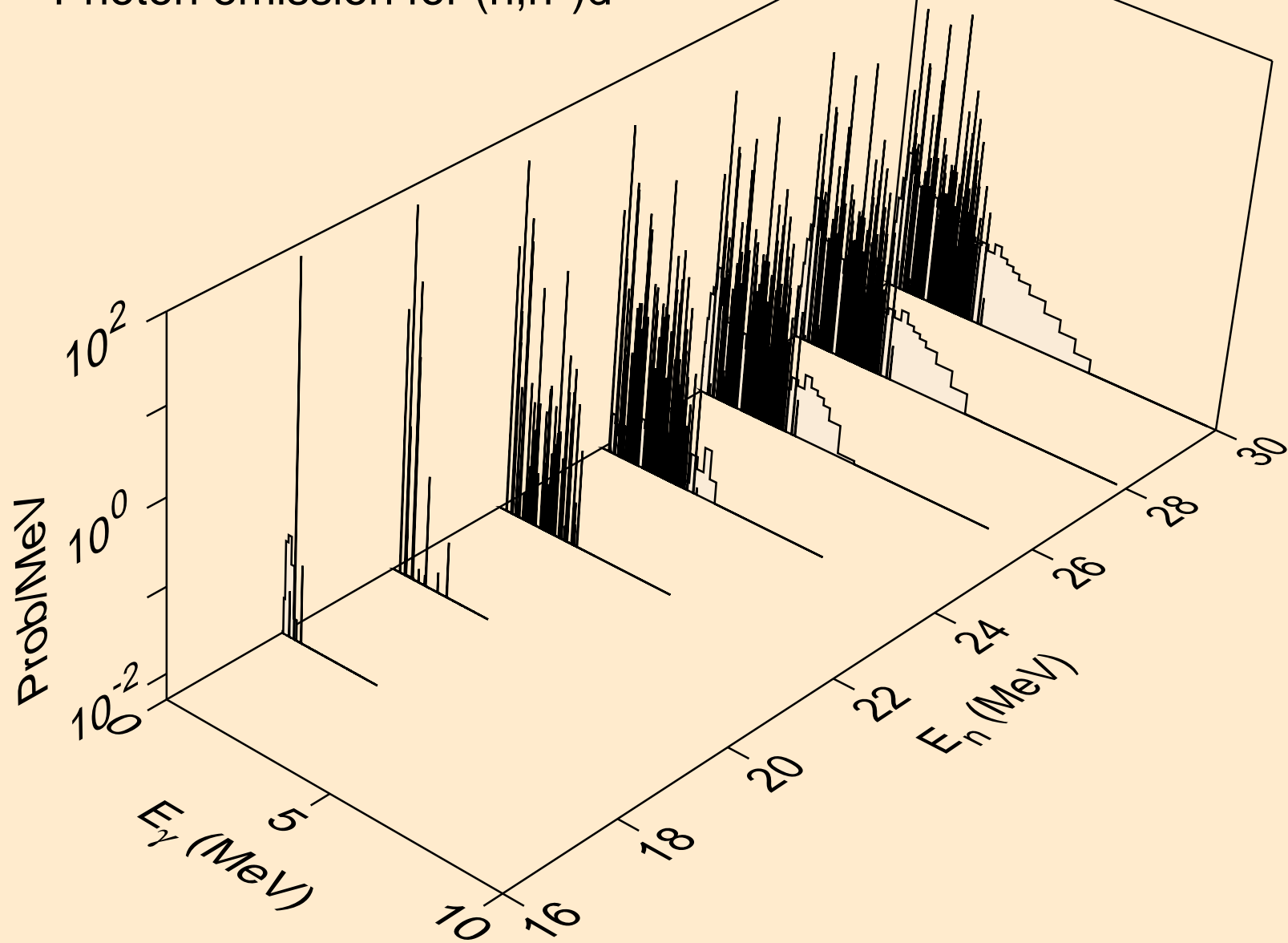

K042 ALPHA ACER TENDL-2024 LIBRARY; T=0.K  
Photon emission for (n,n\*)t

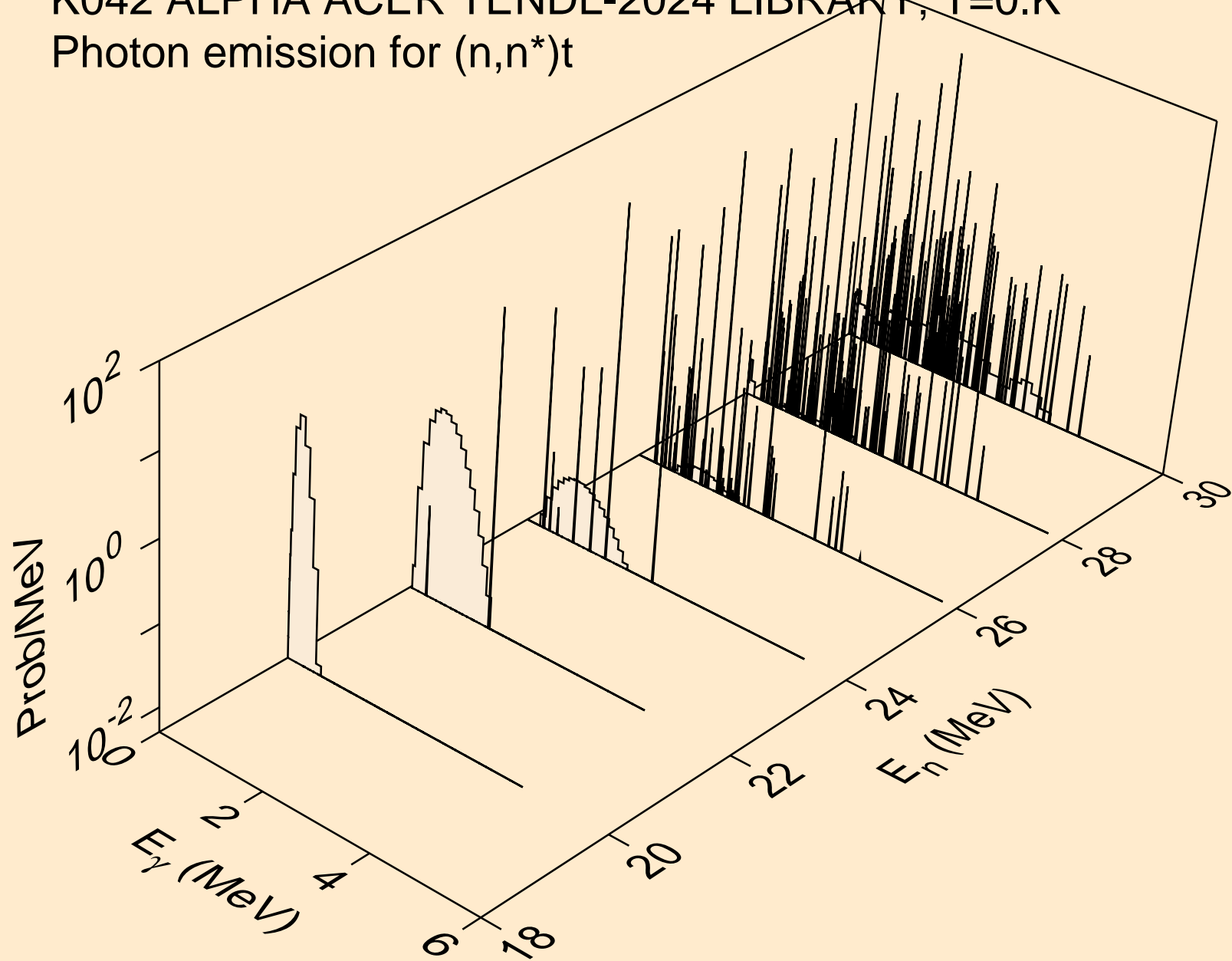

K042 ALPHA ACER TENDL-2024 LIBRARY; T=0.K  
Photon emission for (n,n\*)he3

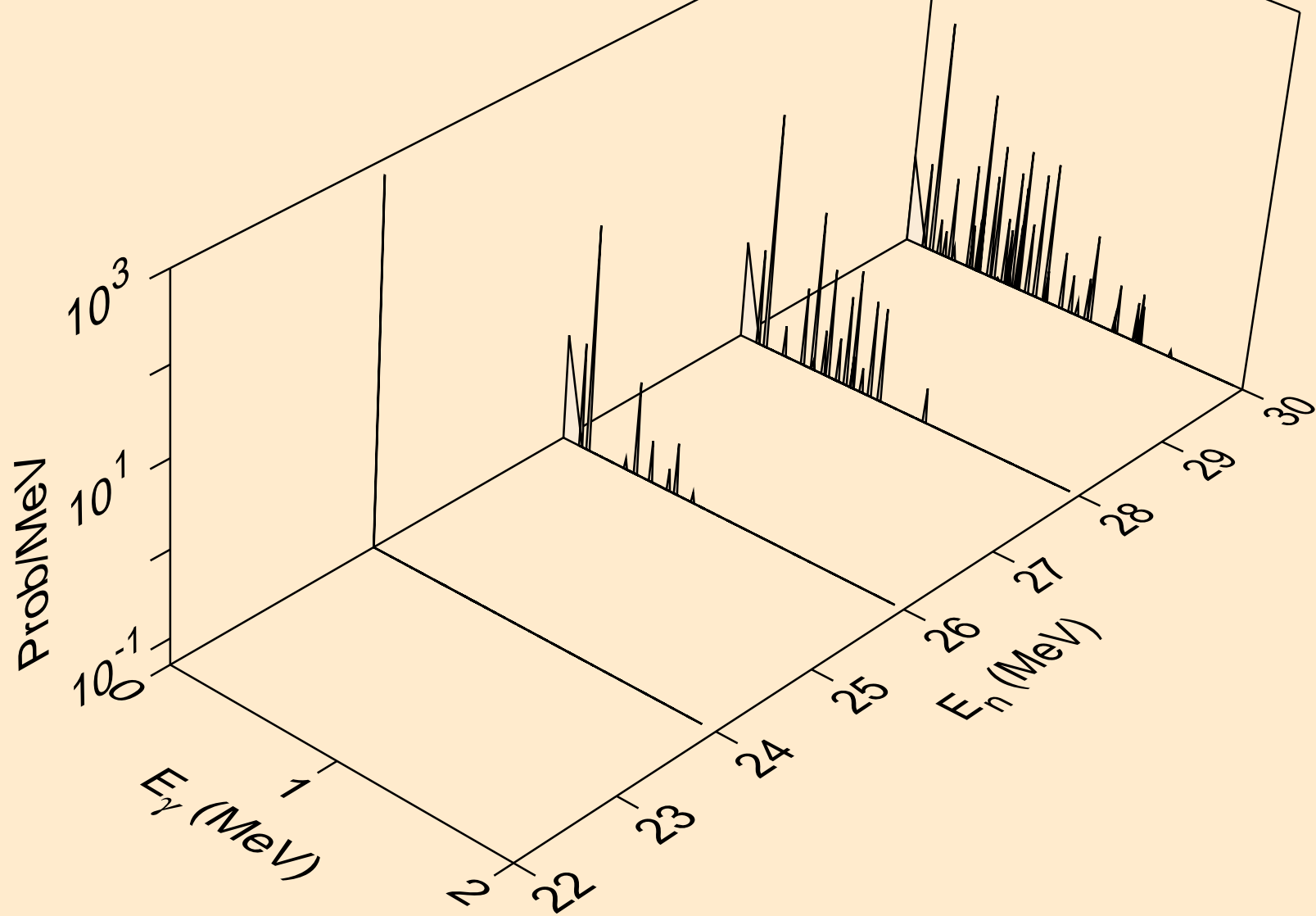

K042 ALPHA ACER TENDL-2024 LIBRARY; T=0.K  
Photon emission for (n,2np)

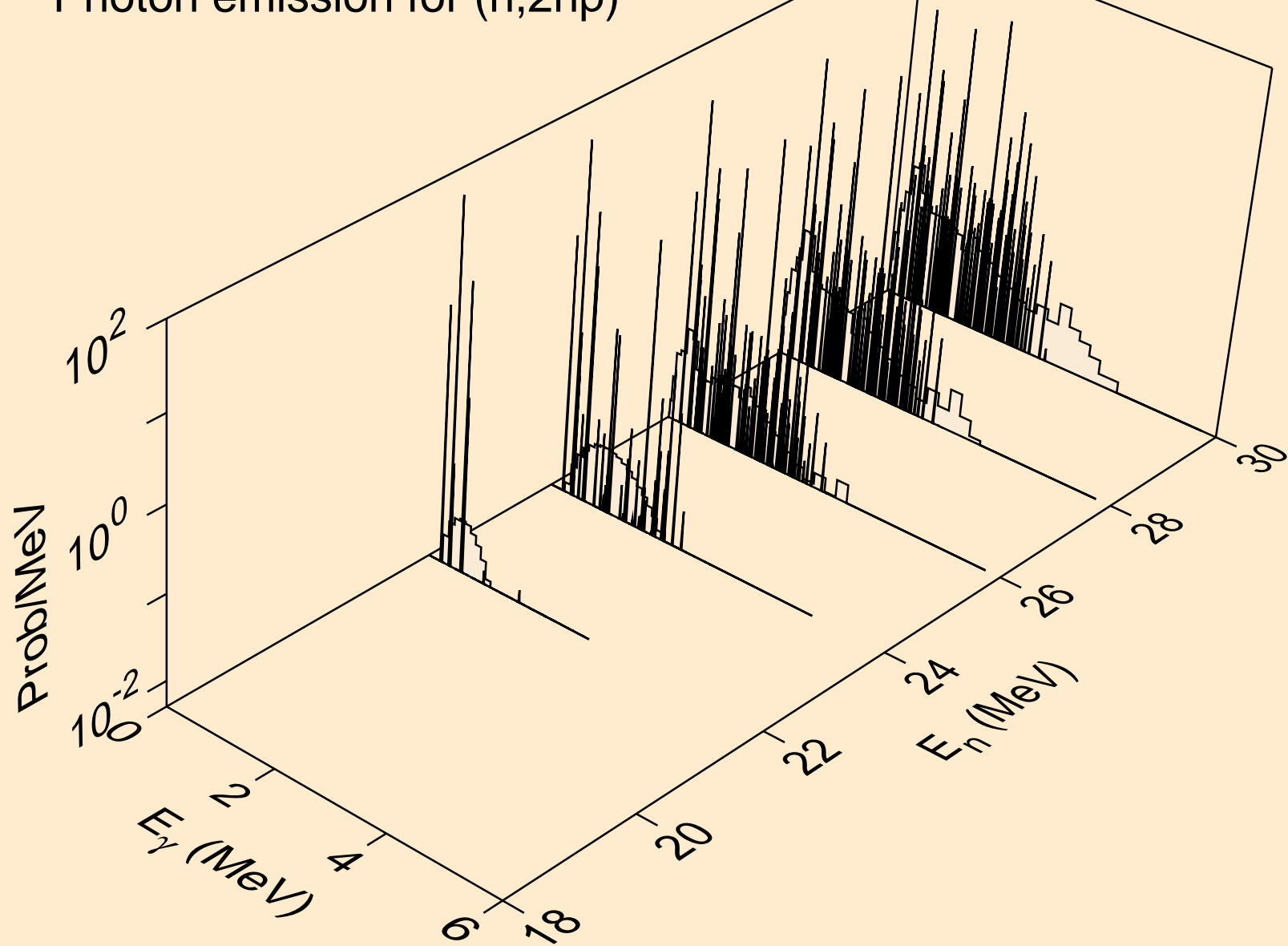

K042 ALPHA ACER TENDL-2024 LIBRARY; T=0.K  
Photon emission for (n,3np)

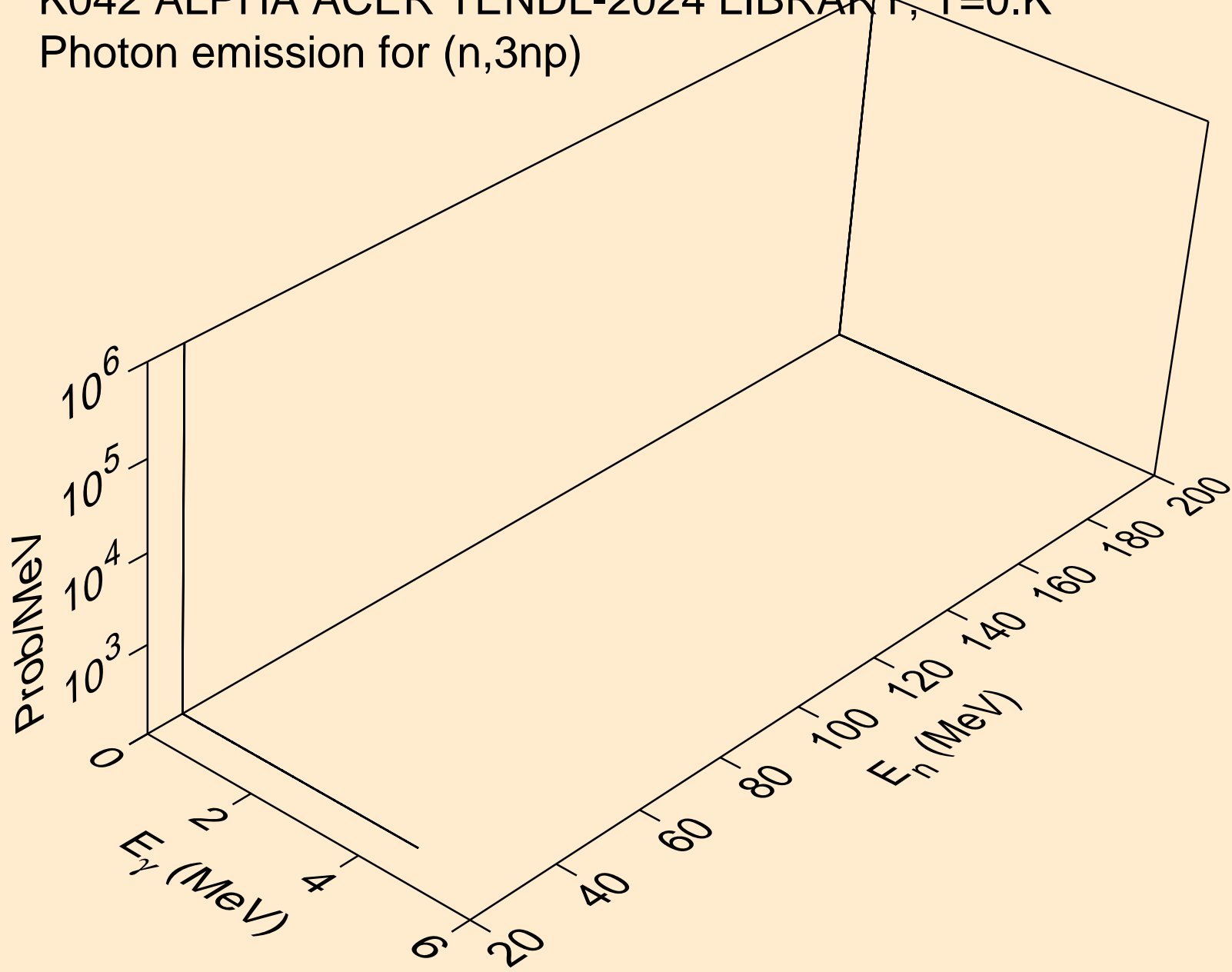

K042 ALPHA ACER TENDL-2024 LIBRARY; T=0.K  
Photon emission for (n,n2p)

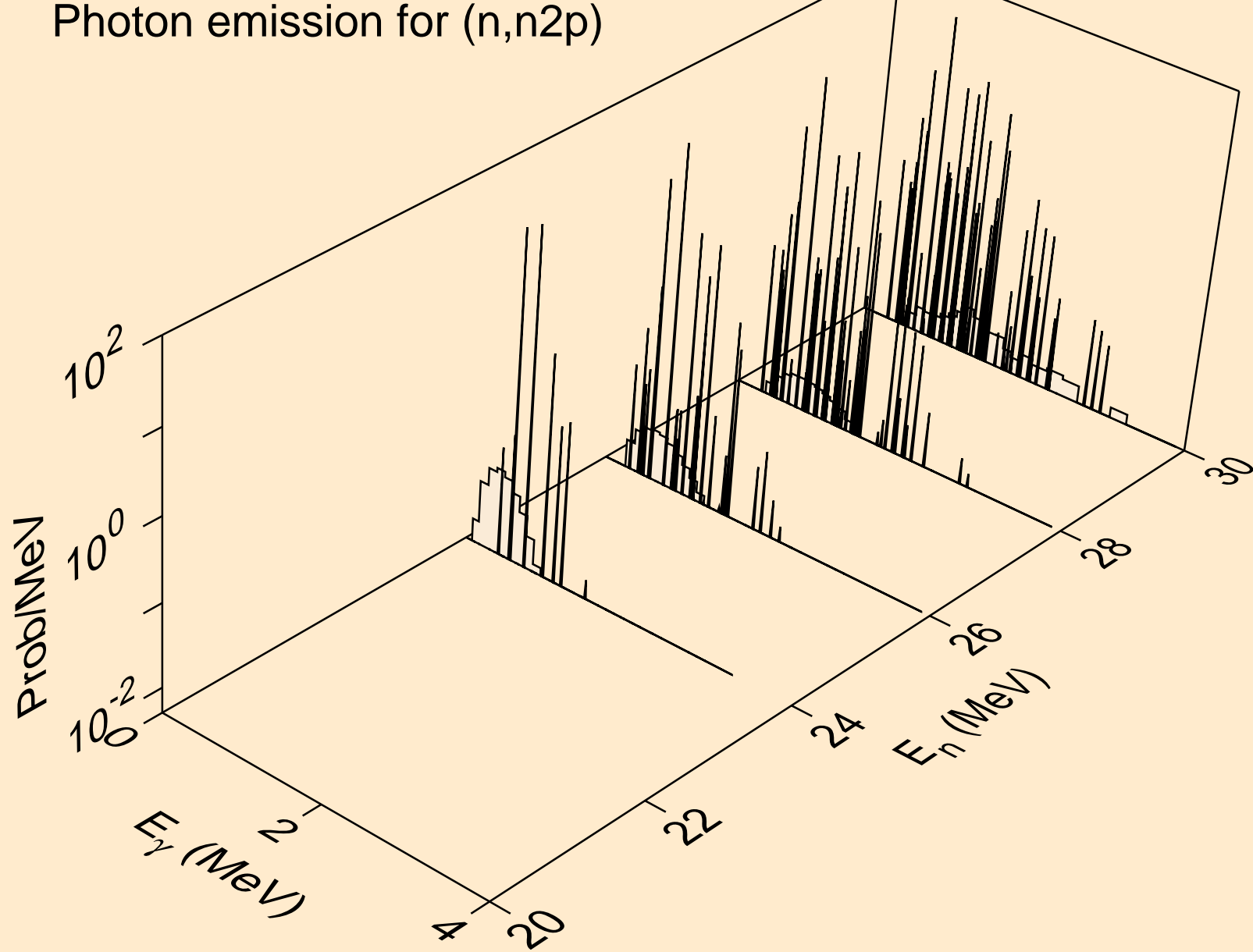

K042 ALPHA ACER TENDL-2024 LIBRARY; T=0.K  
Photon emission for (n,npa)

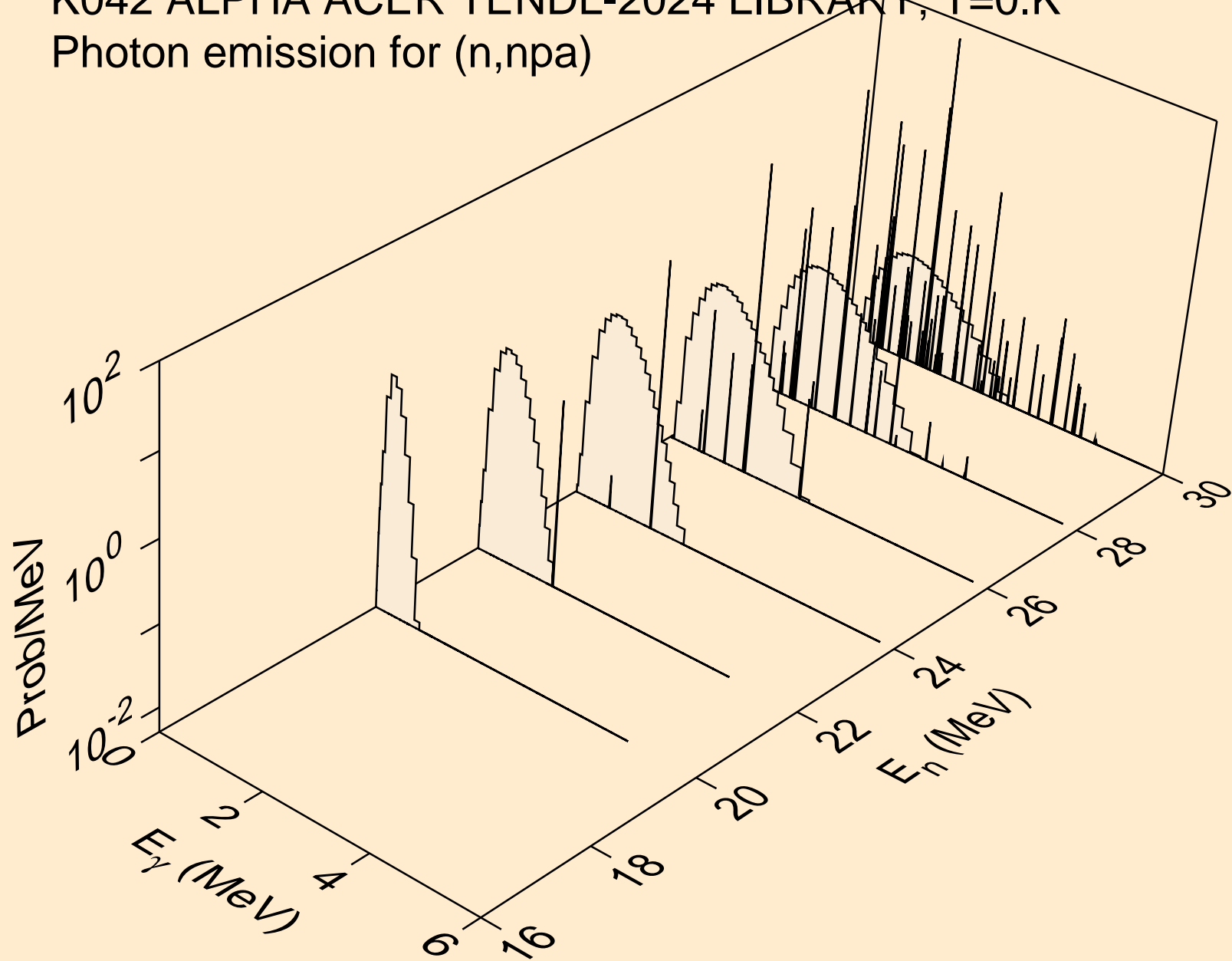

K042 ALPHA ACER TENDL-2024 LIBRARY; T=0.K  
Photon emission for (n,gma)

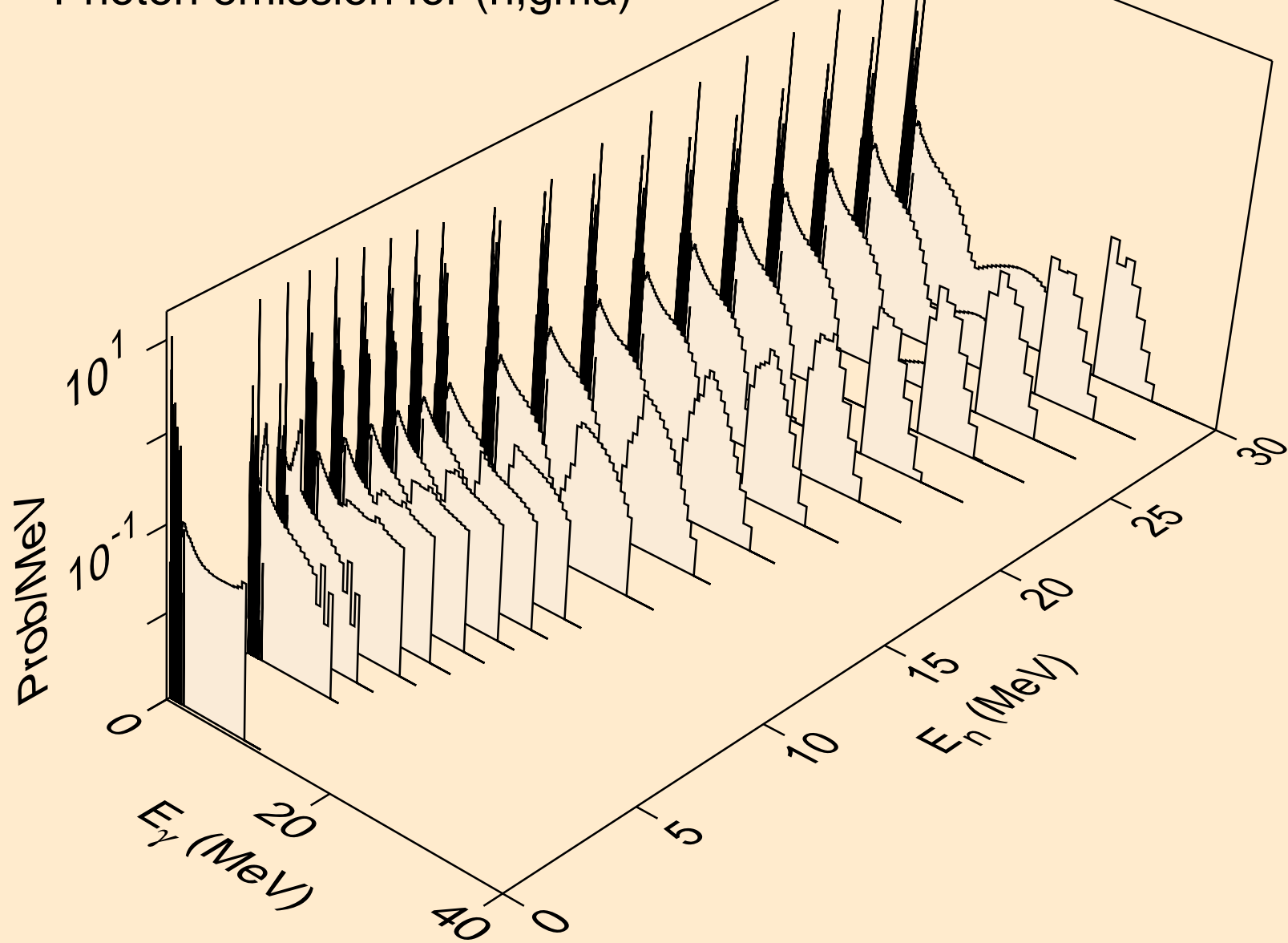

K042 ALPHA ACER TENDL-2024 LIBRARY; T=0.K  
Photon emission for (n,p)

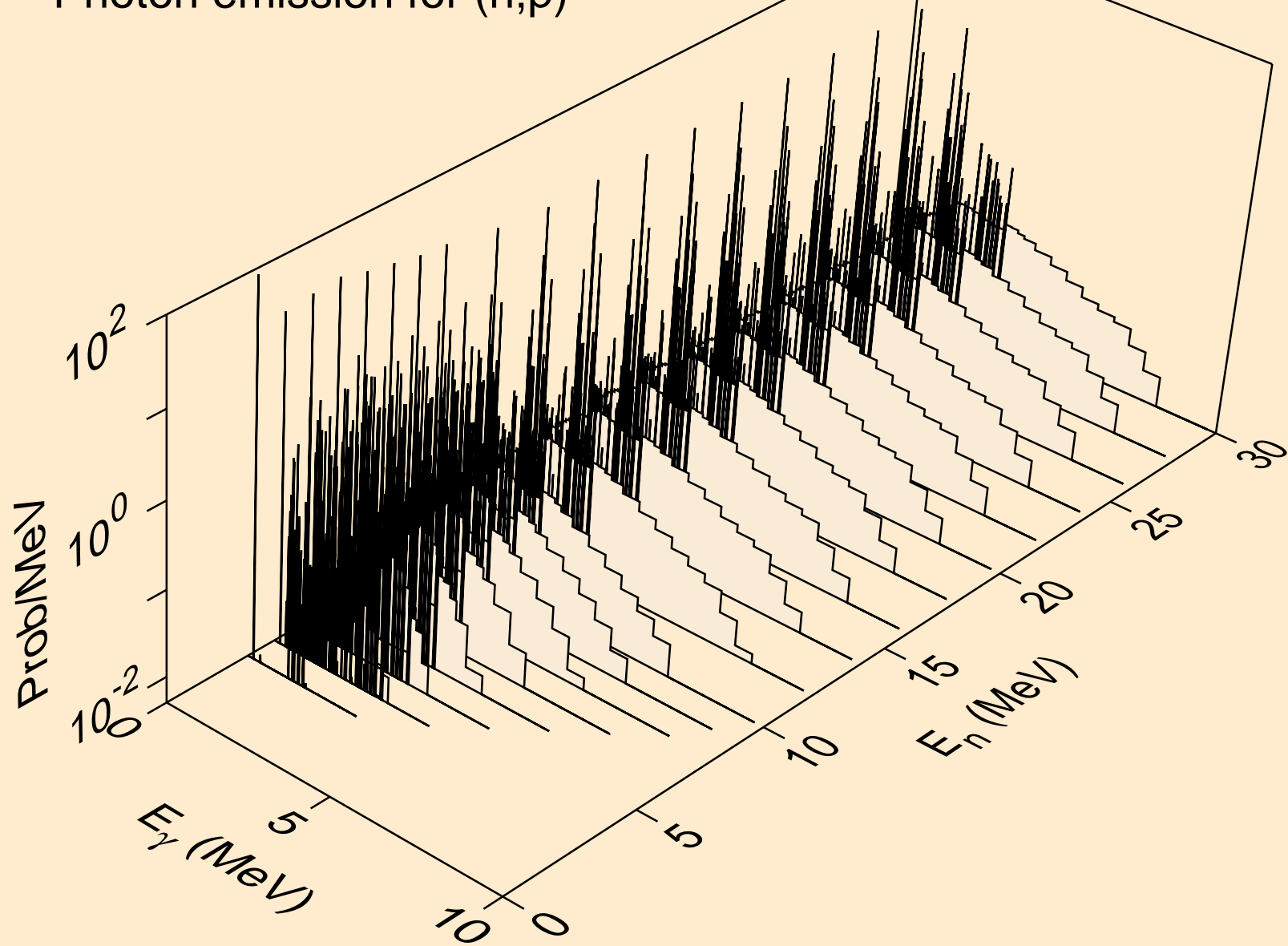

K042 ALPHA ACER TENDL-2024 LIBRARY; T=0.K  
Photon emission for (n,d)

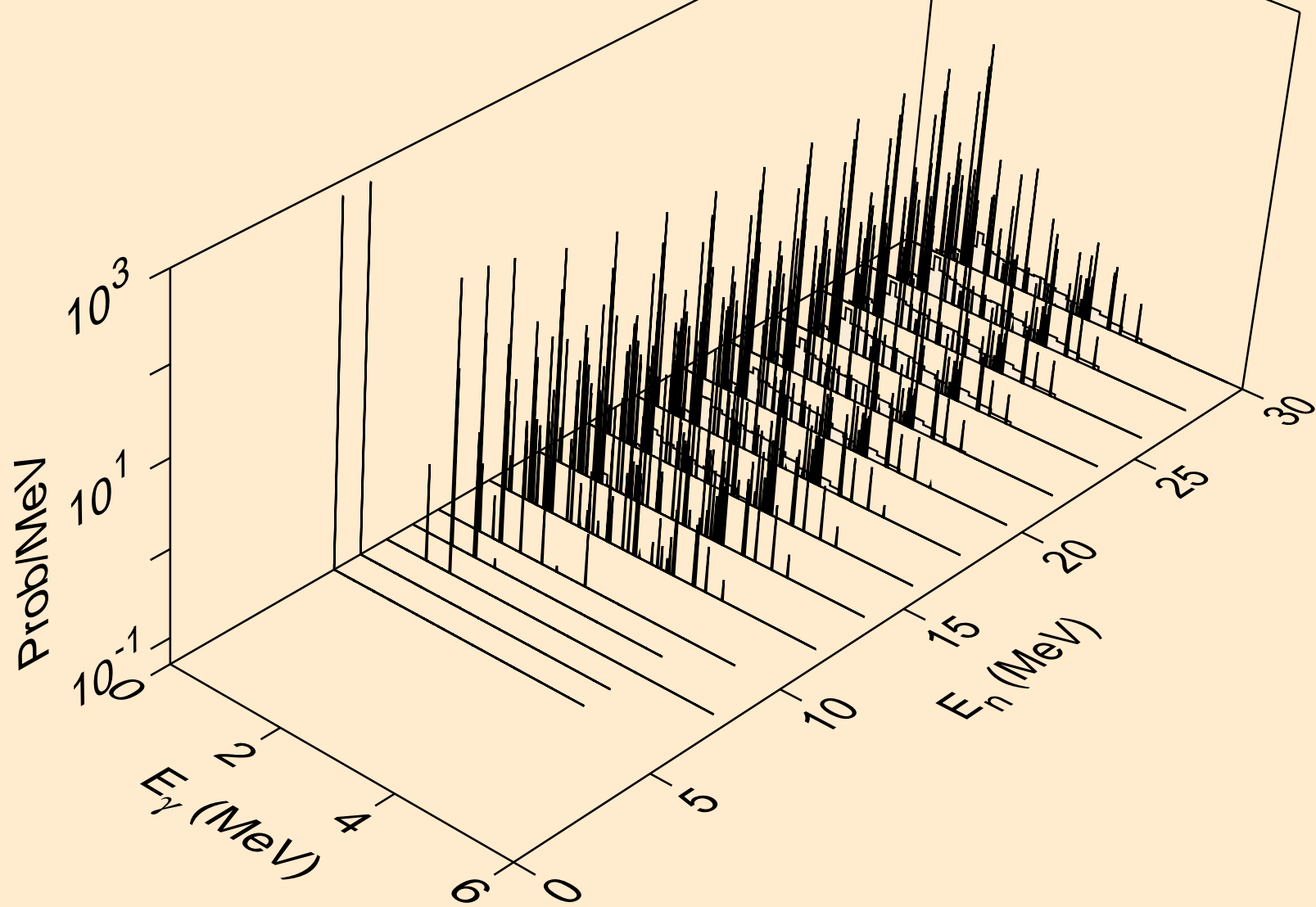

K042 ALPHA ACER TENDL-2024 LIBRARY; T=0.K  
Photon emission for (n,t)

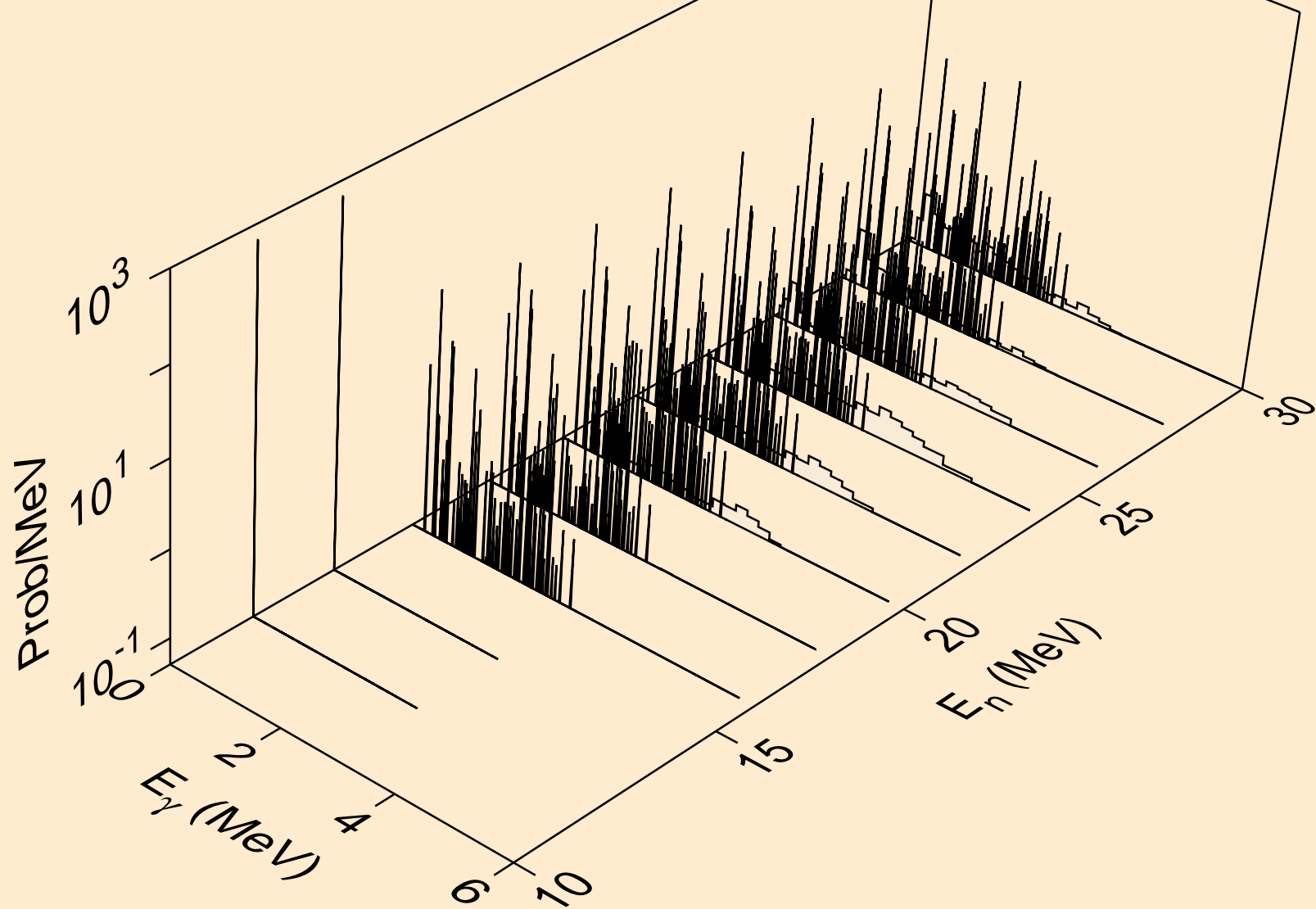

K042 ALPHA ACER TENDL-2024 LIBRARY; T=0.K  
Photon emission for (n,he3)

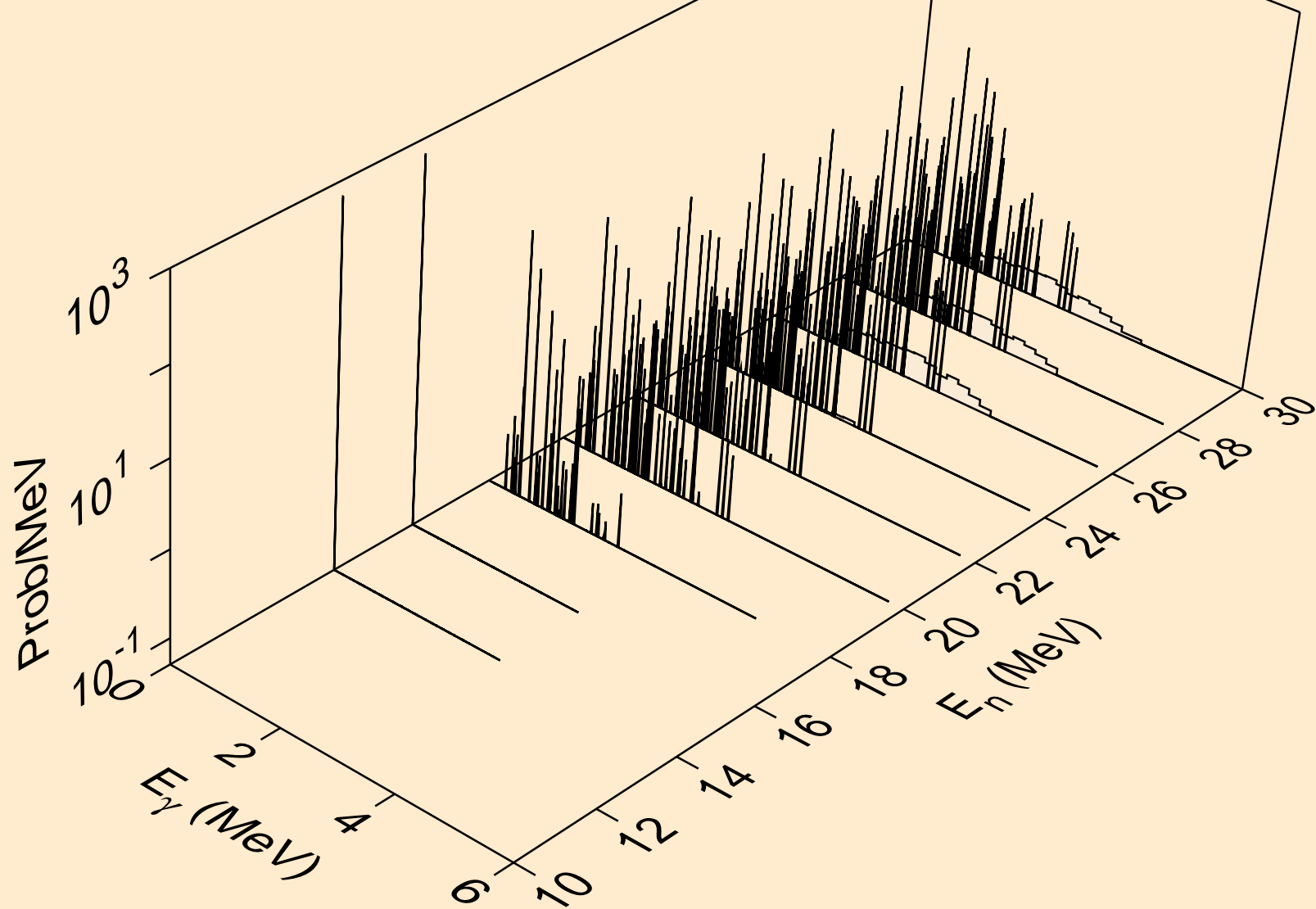

K042 ALPHA ACER TENDL-2024 LIBRARY; T=0.K  
Photon emission for inelastic

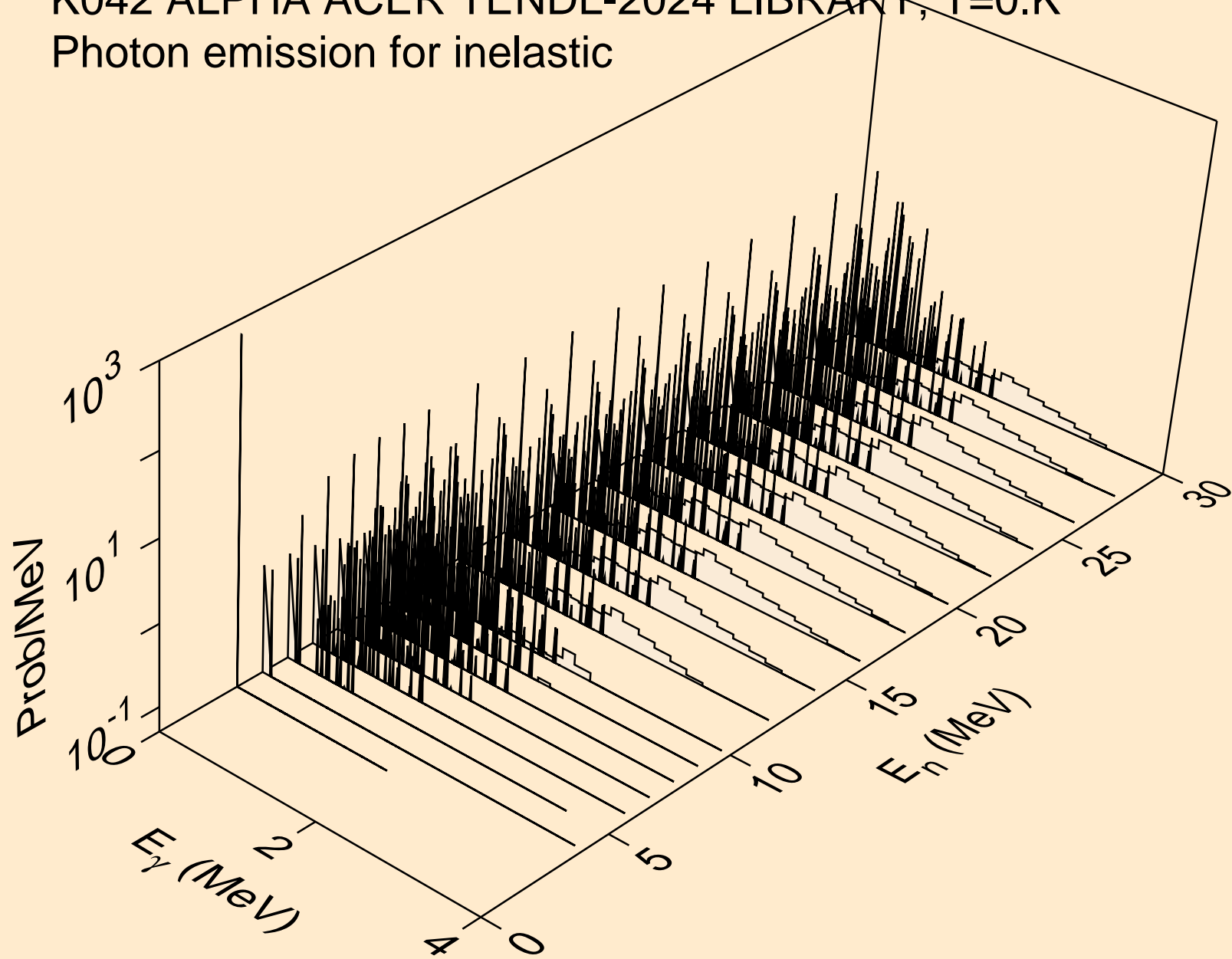

K042 ALPHA ACER TENDL-2024 LIBRARY; T=0.K  
Photon emission for (n,2a)

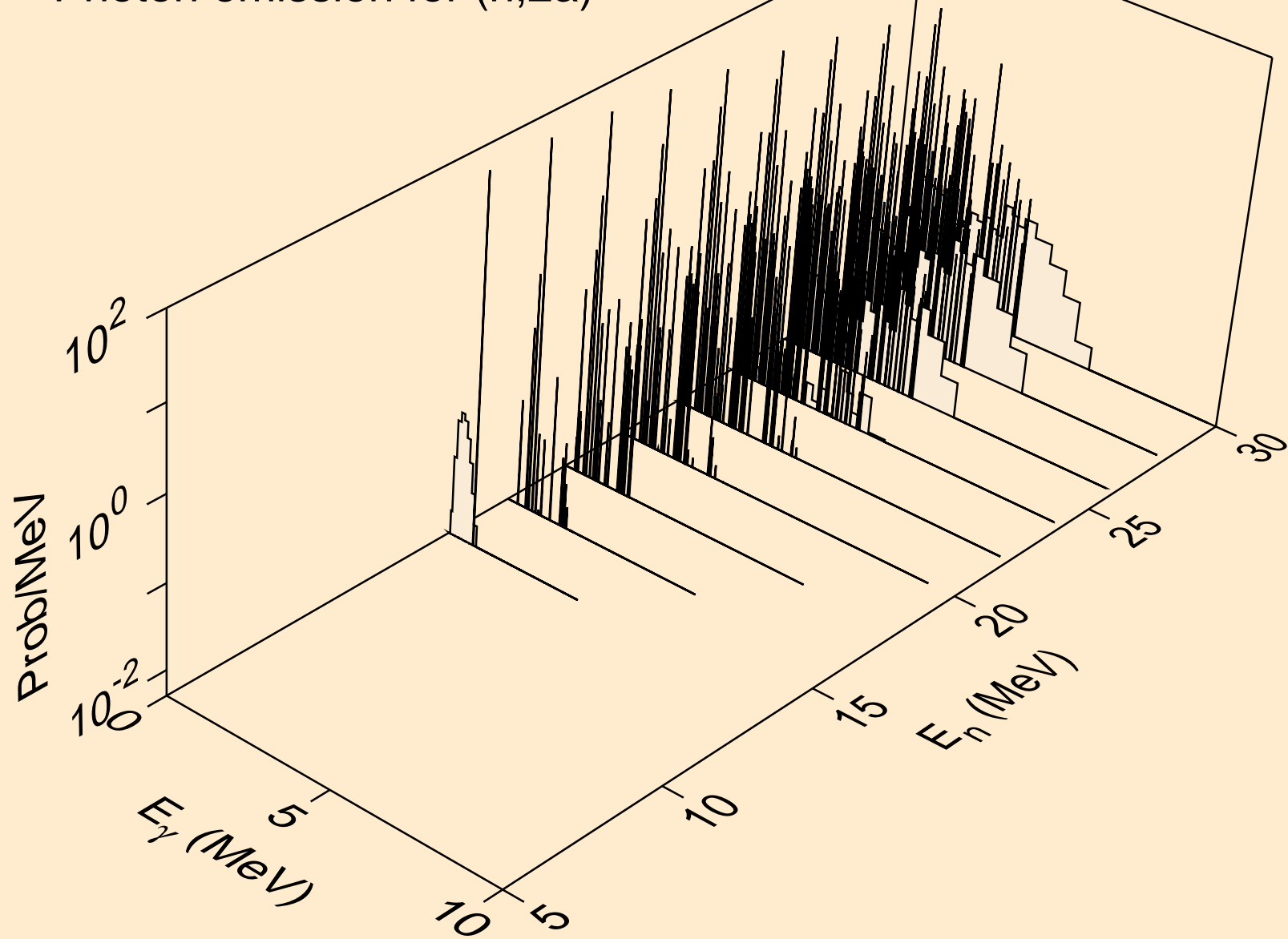

K042 ALPHA ACER TENDL-2024 LIBRARY; T=0.K  
Photon emission for (n,2p)

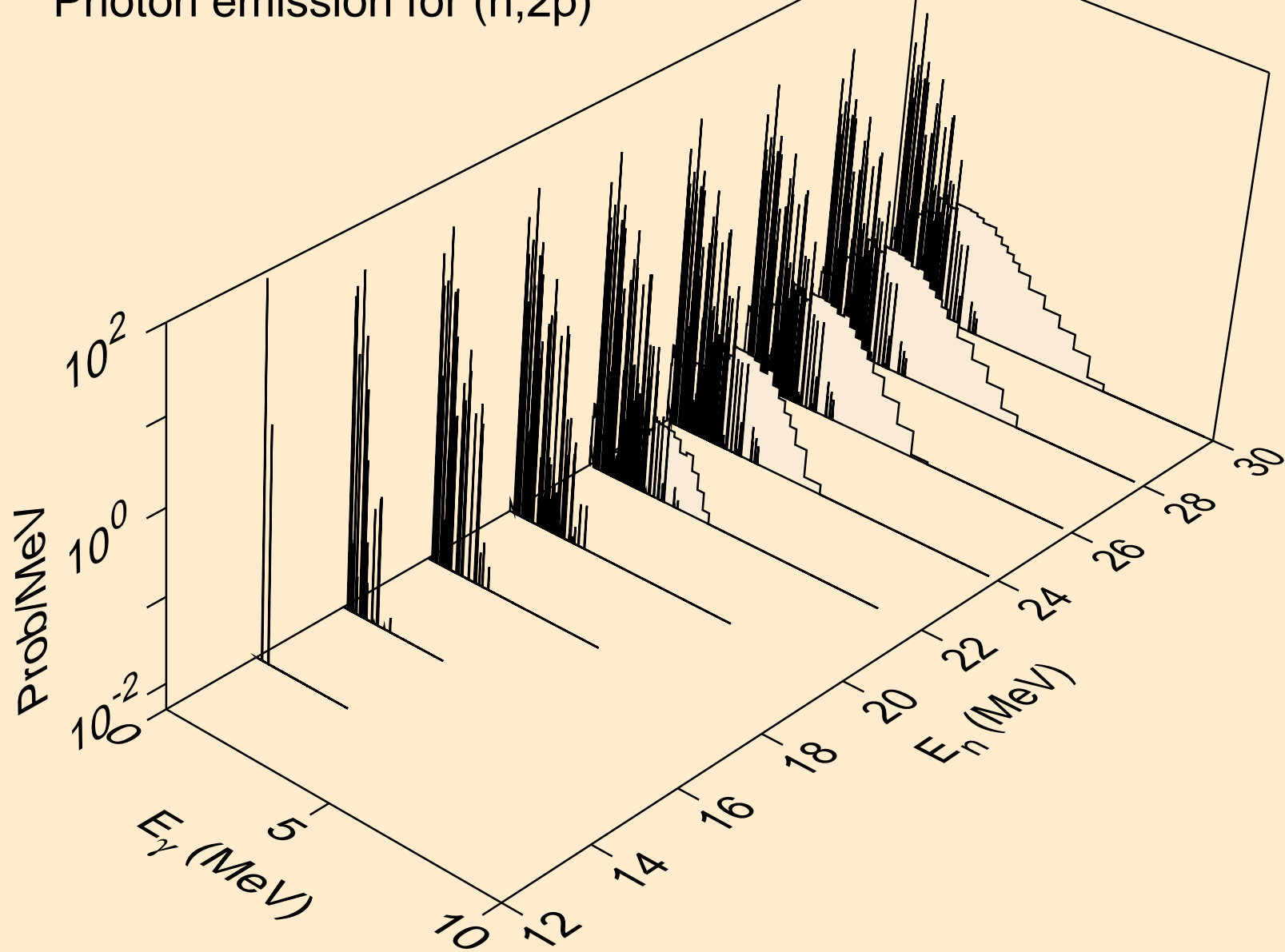

K042 ALPHA ACER TENDL-2024 LIBRARY; T=0.K  
Photon emission for (n,pa)

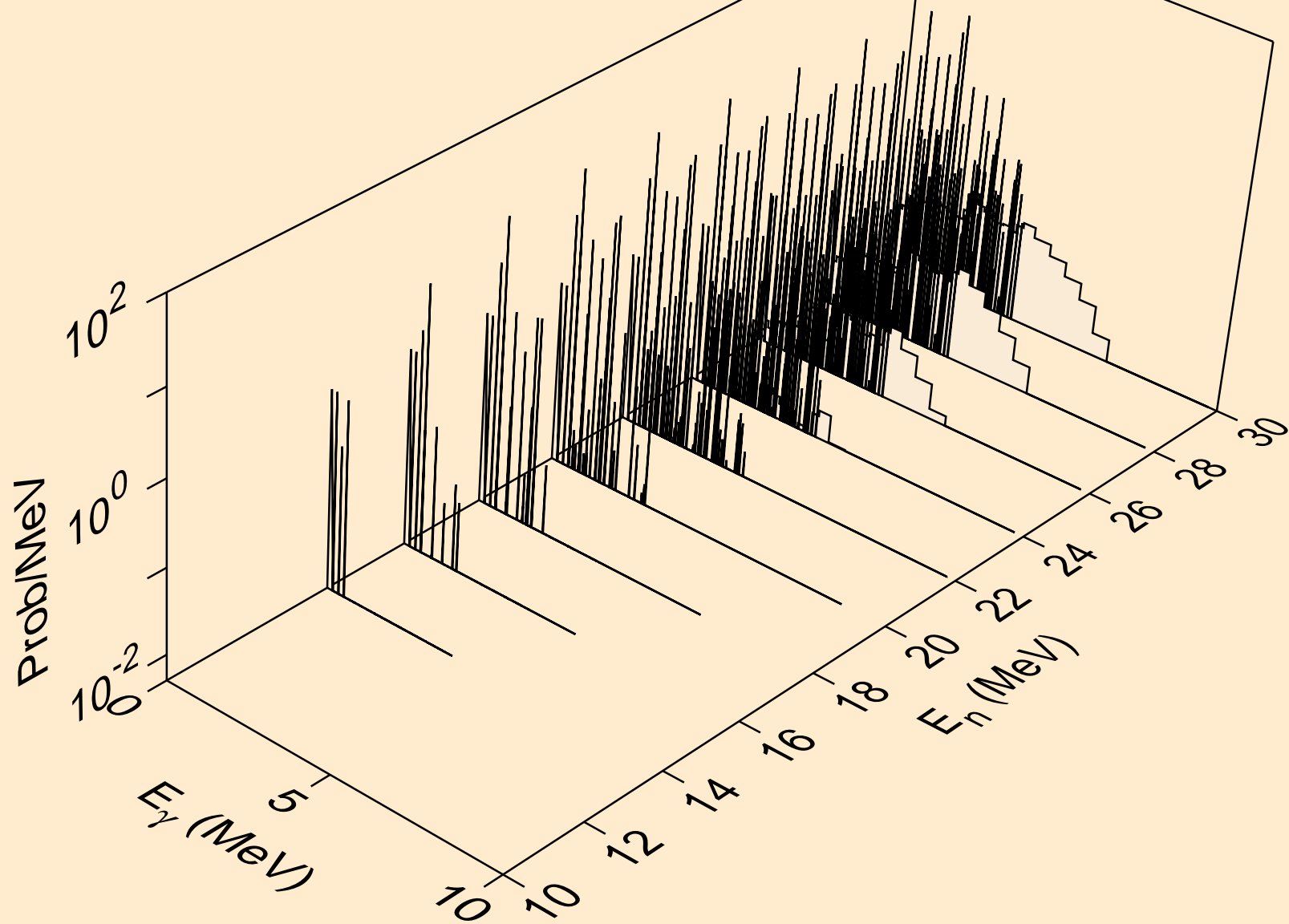

K042 ALPHA ACER TENDL-2024 LIBRARY; T=0.K  
Photon emission for (n,pd)

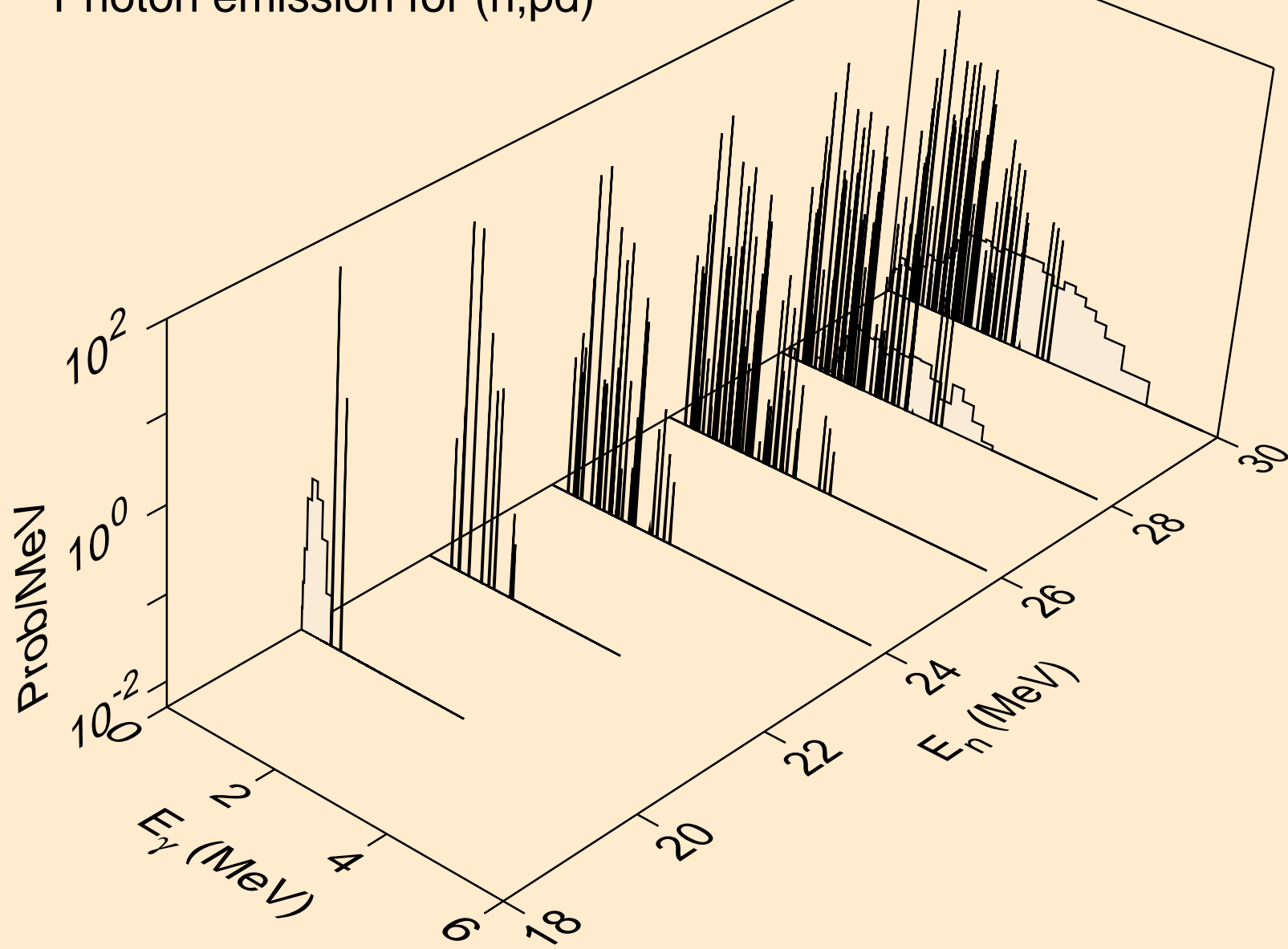

K042 ALPHA ACER TENDL-2024 LIBRARY; T=0.K  
Photon emission for (n,pt)

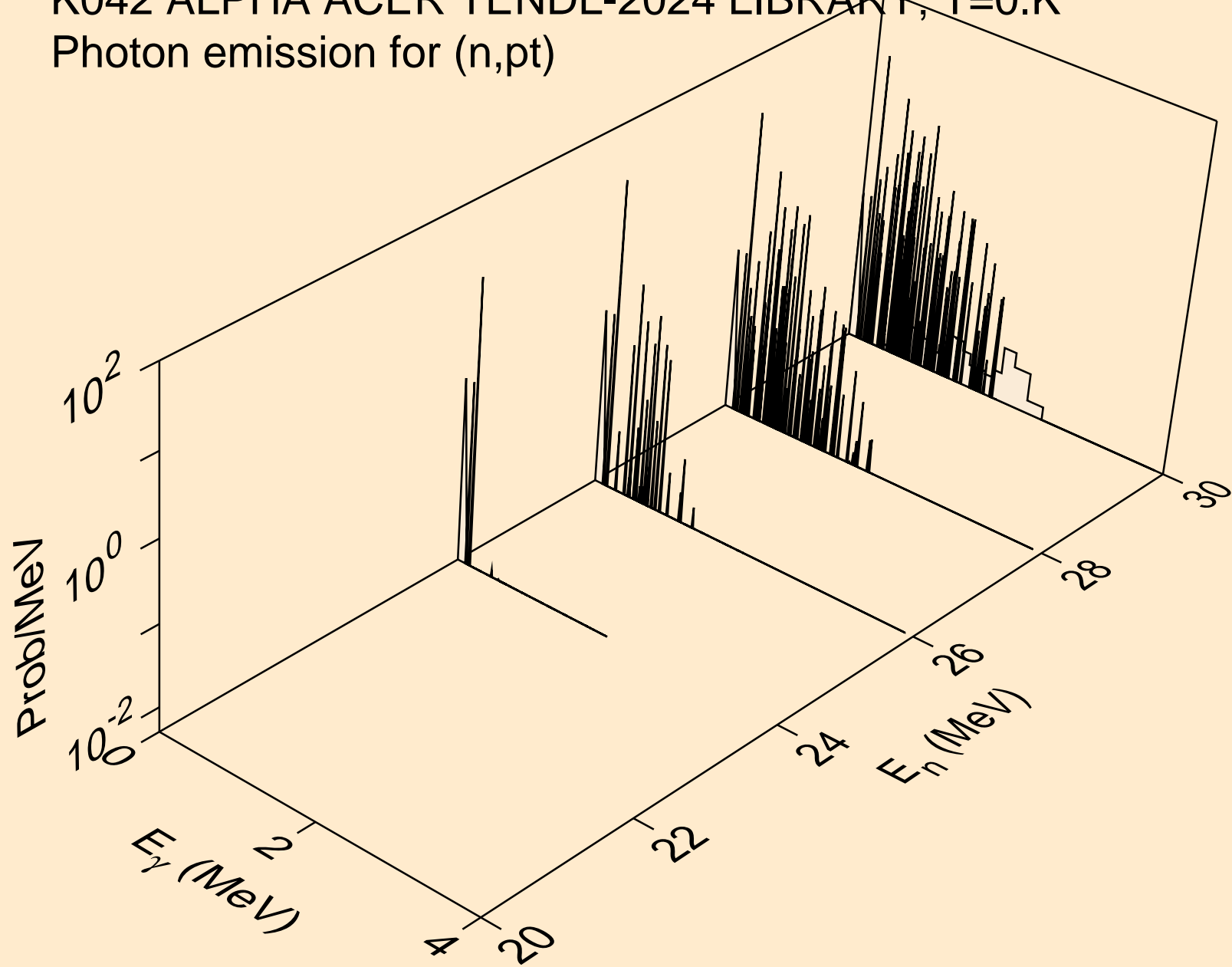

K042 ALPHA ACER TENDL-2024 LIBRARY; T=0.K  
Photon emission for (n,da)

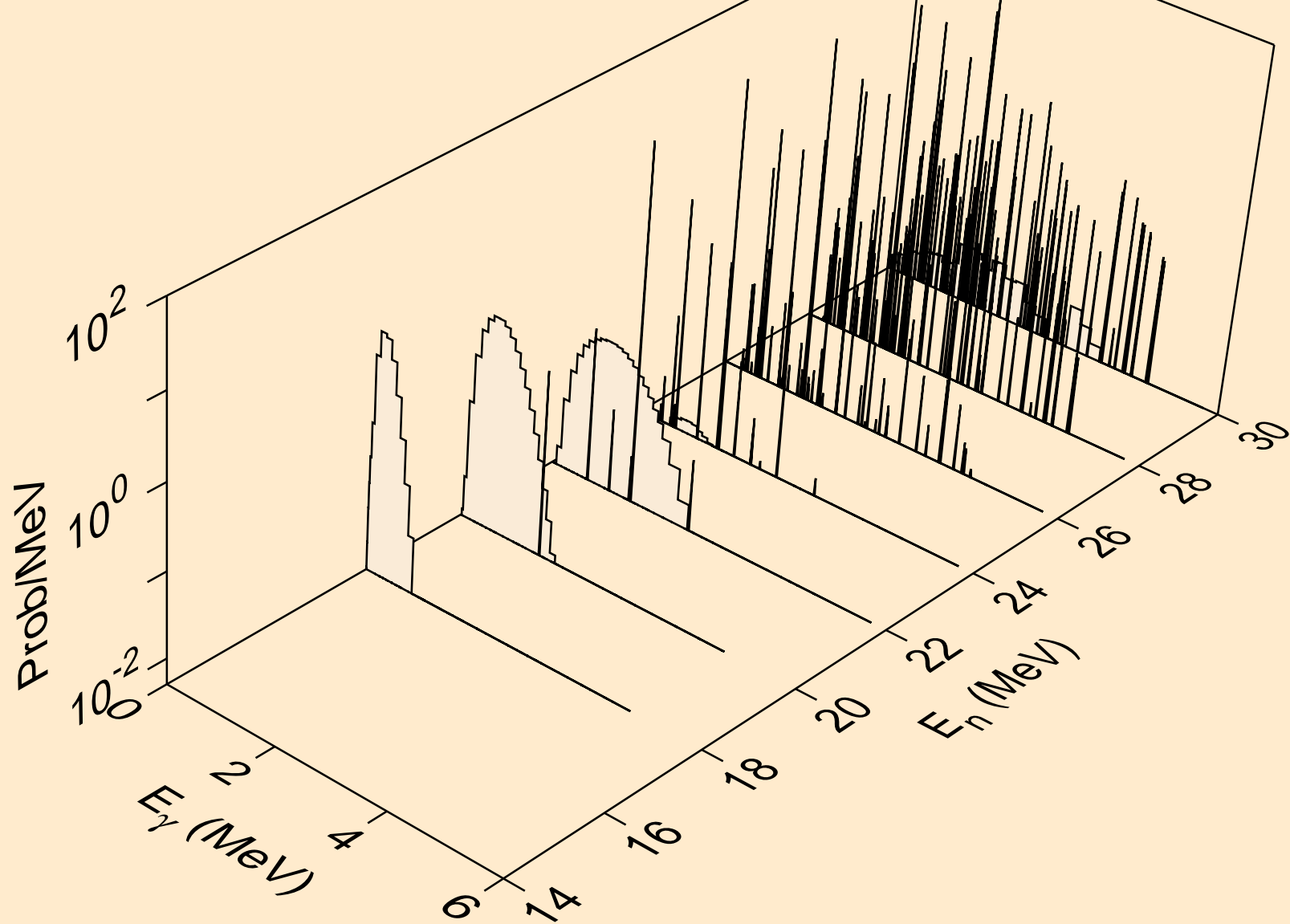

K042 ALPHA ACER TENDL-2024 LIBRARY; T=0.K  
Particle heating contributions

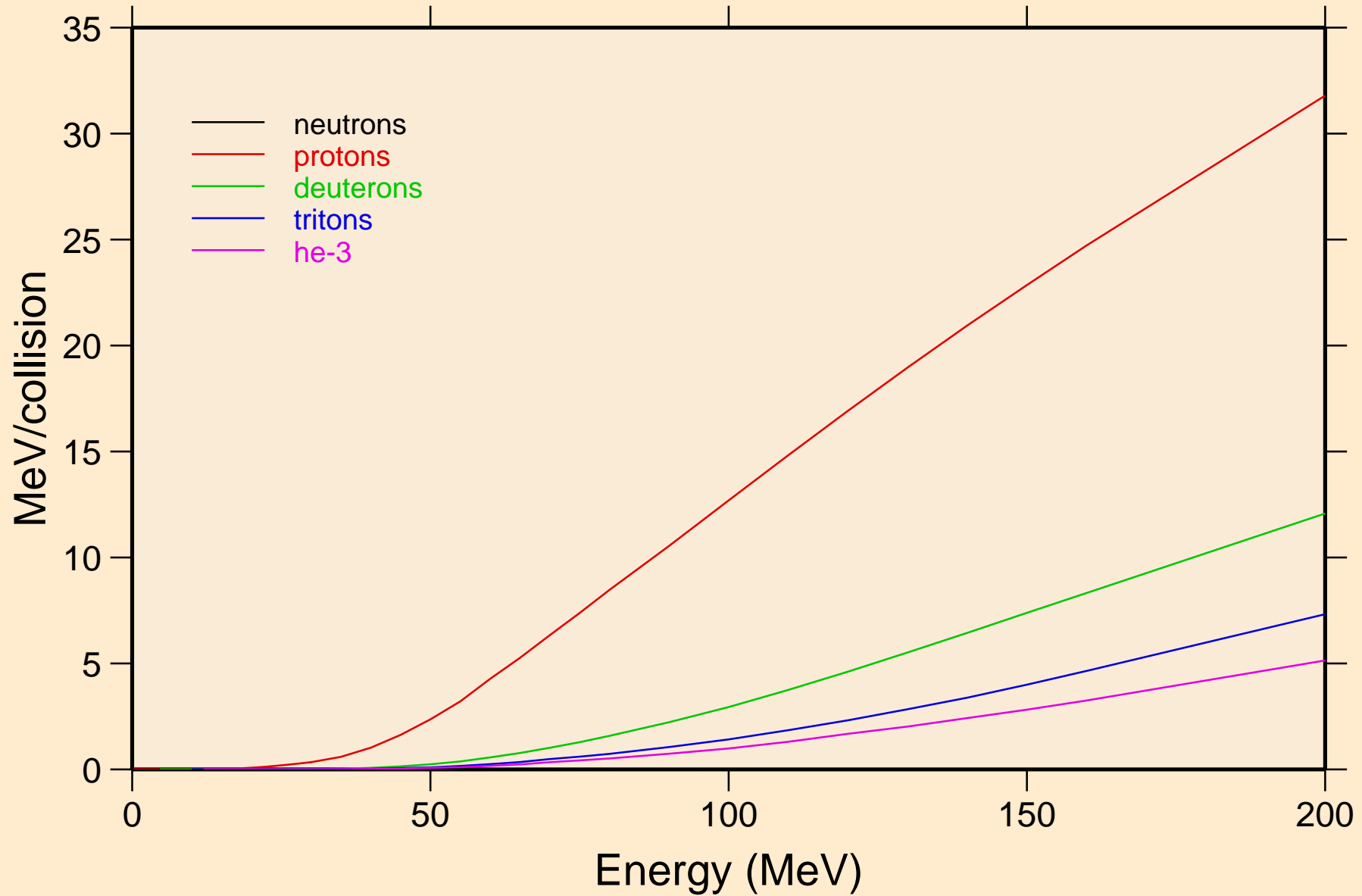

K042 ALPHA ACER TENDL-2024 LIBRARY; T=0.K  
Recoil Heating

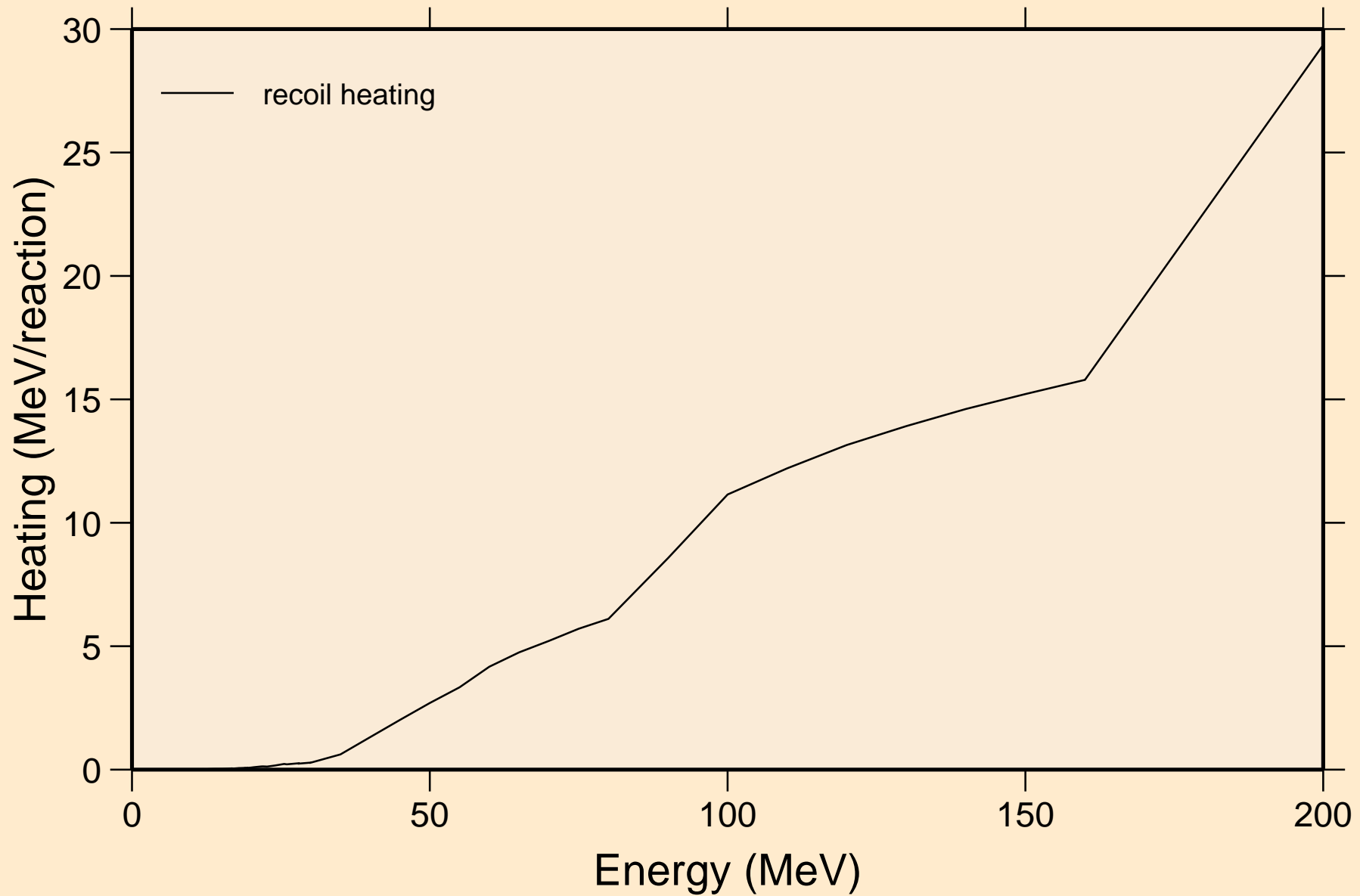

K042 ALPHA ACER TENDL-2024 LIBRARY; T=0.K  
Particle production cross sections

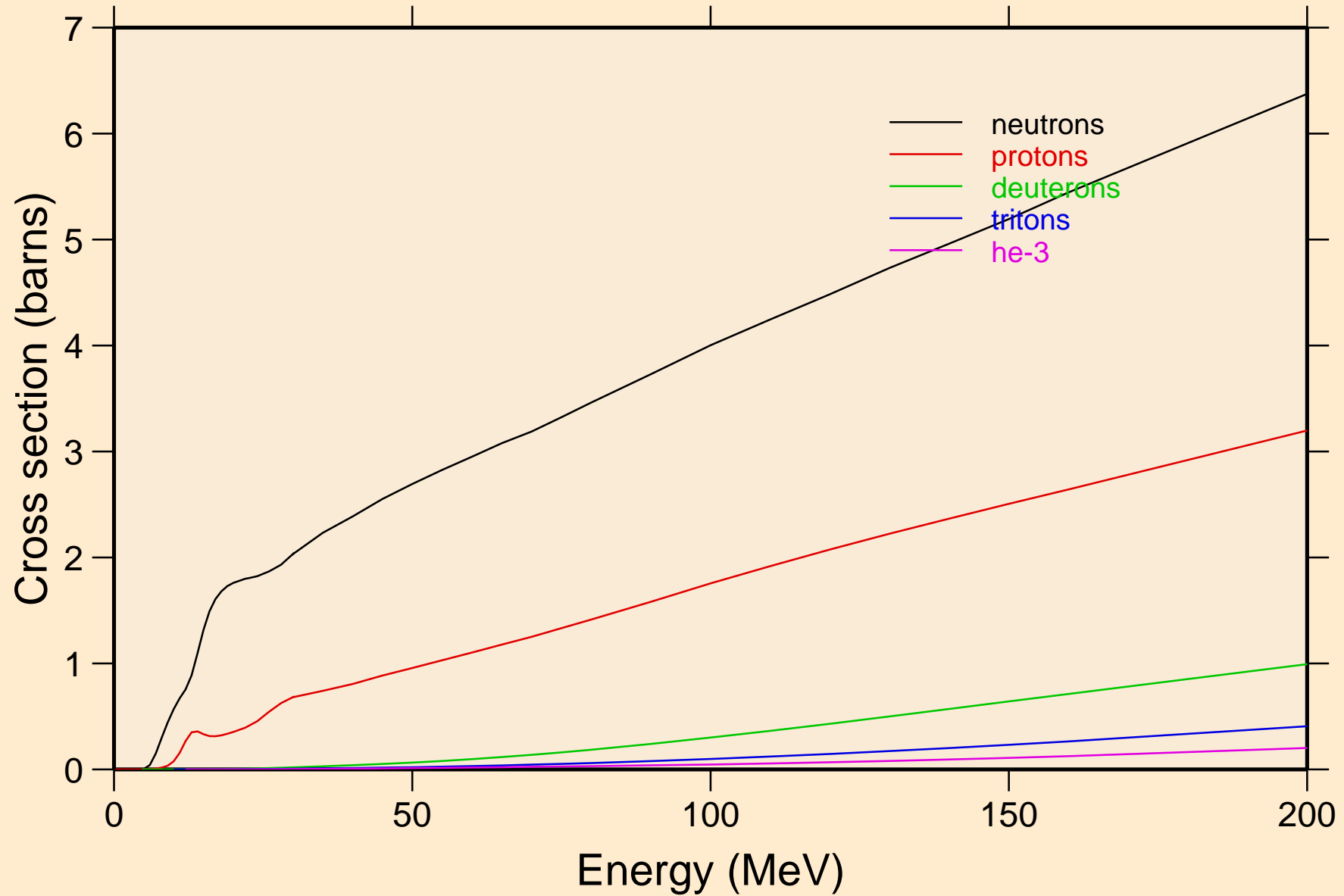

K042 ALPHA ACER TENDL-2024 LIBRARY; T=0.K  
neutrons from (a,n)

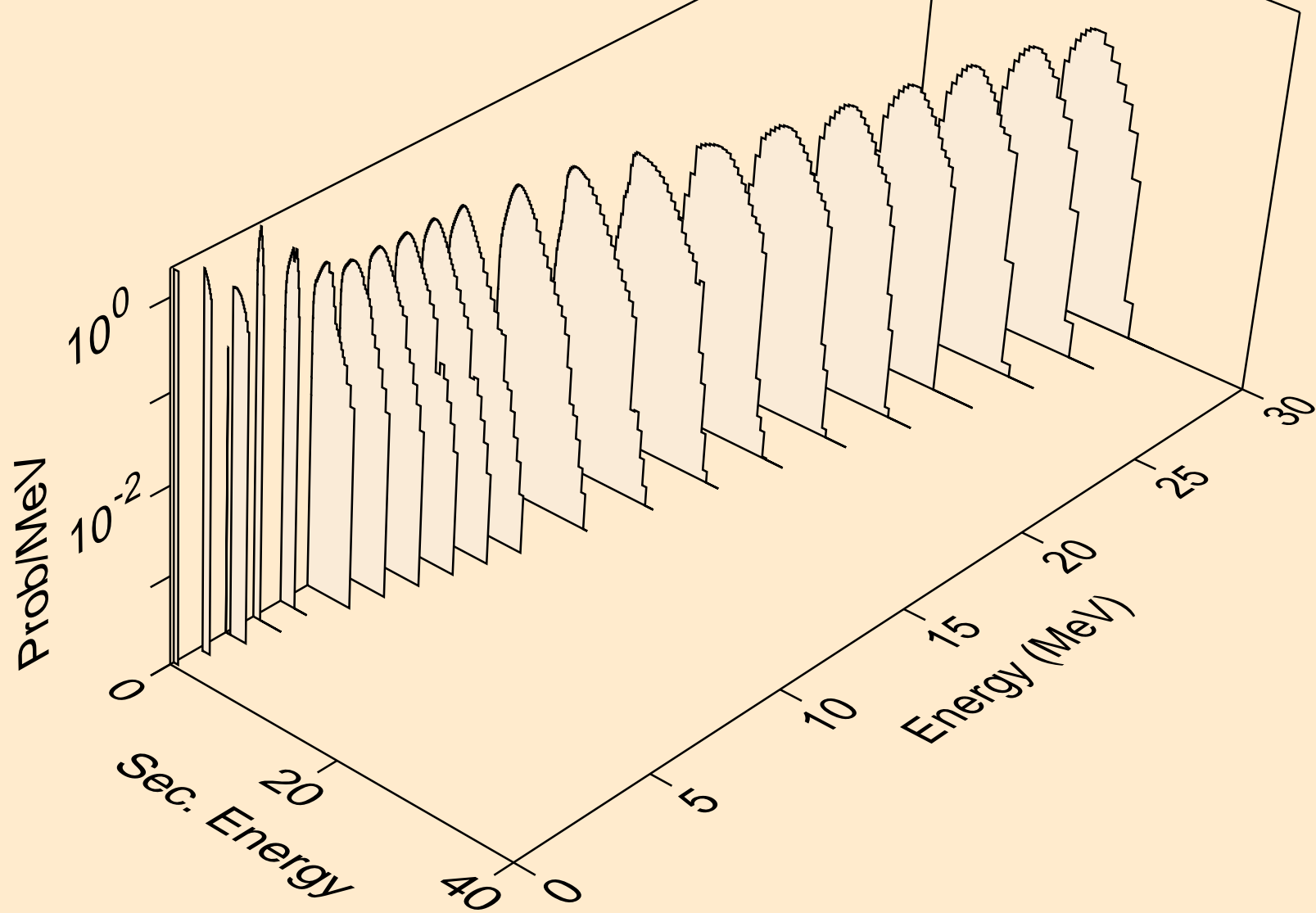

K042 ALPHA ACER TENDL-2024 LIBRARY; T=0.K  
neutrons from (a,x)

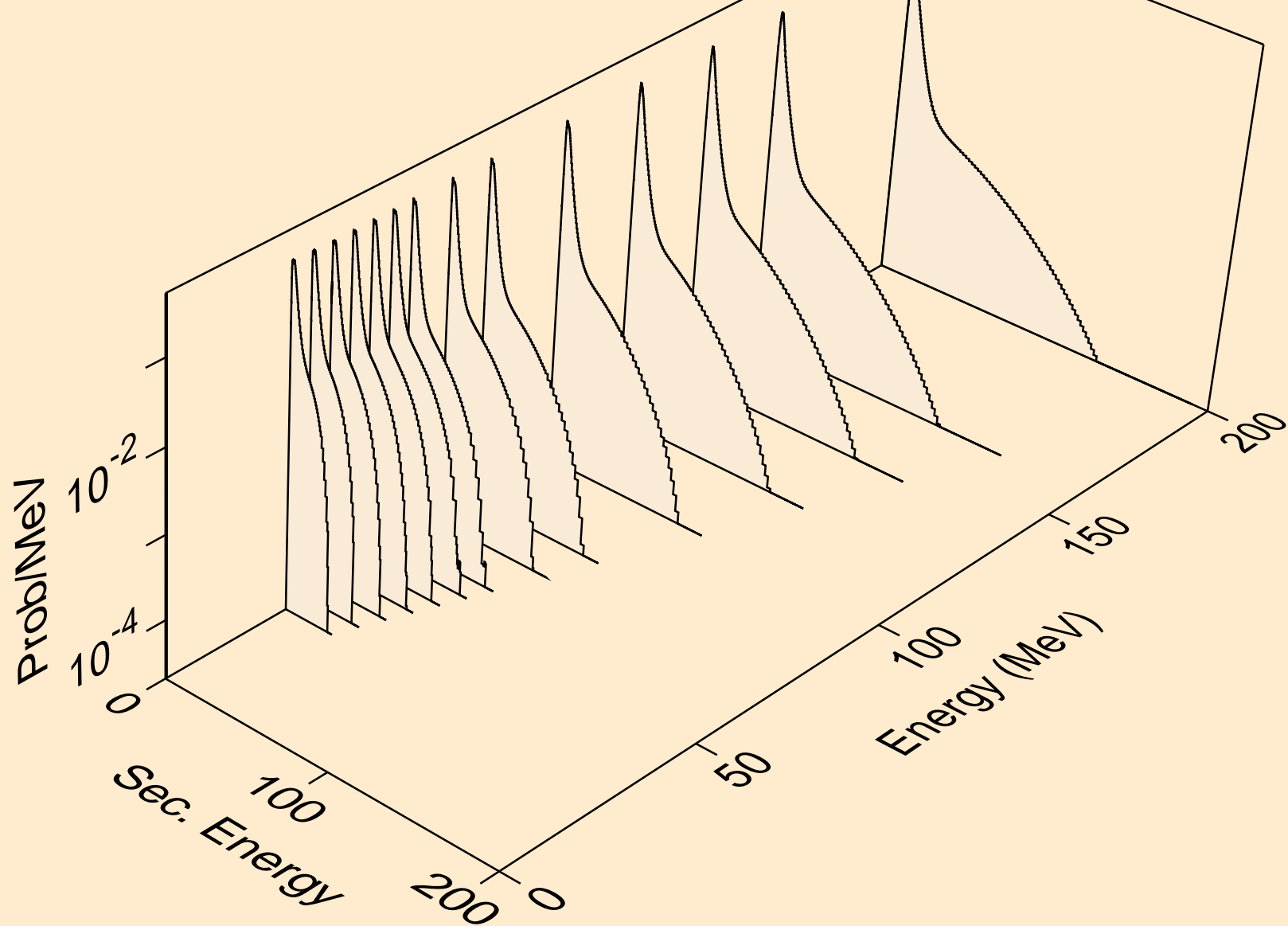

K042 ALPHA ACER TENDL-2024 LIBRARY; T=0.K  
neutrons from (a,2nd)

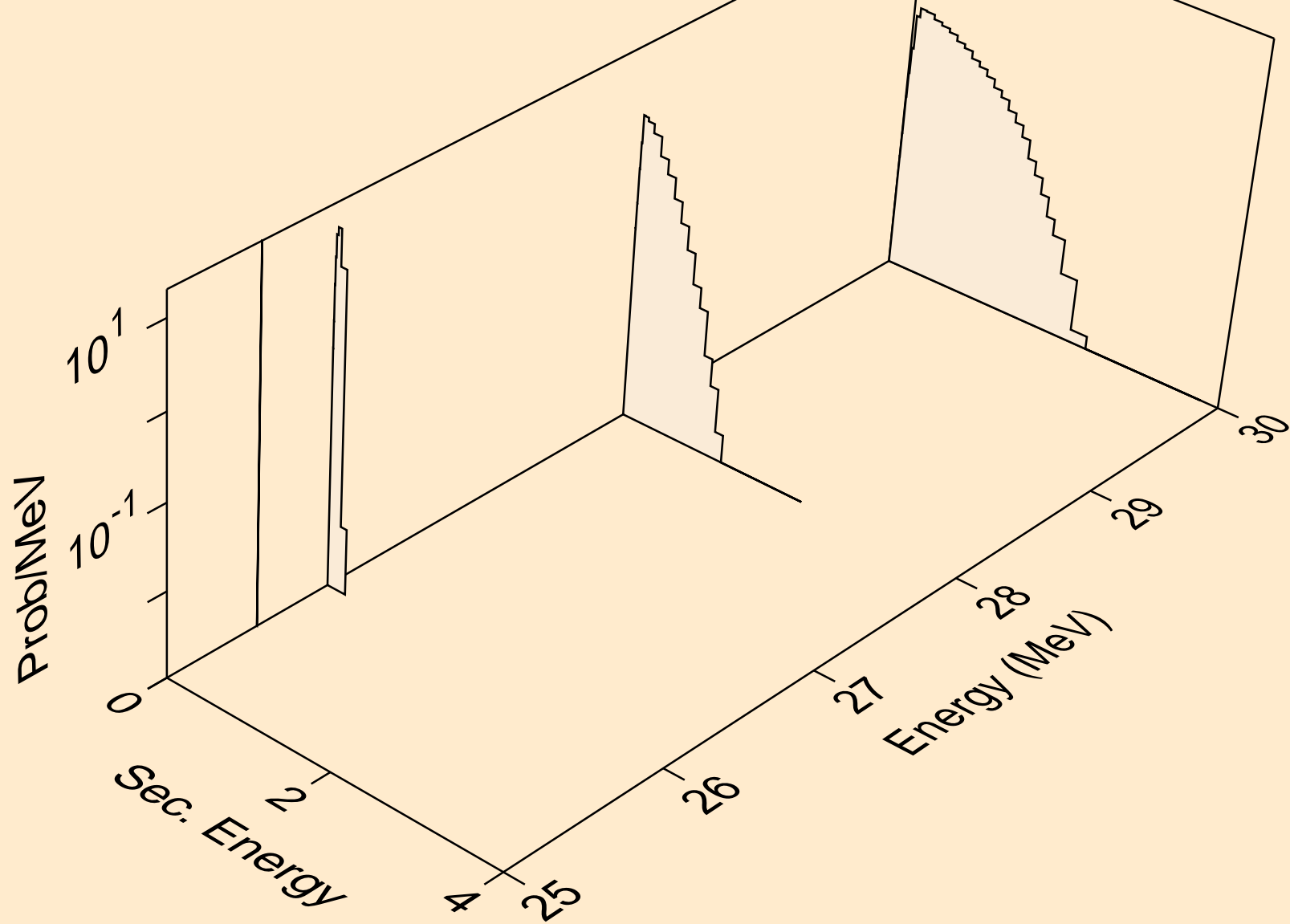

K042 ALPHA ACER TENDL-2024 LIBRARY; T=0.K  
neutrons from (a,2n)

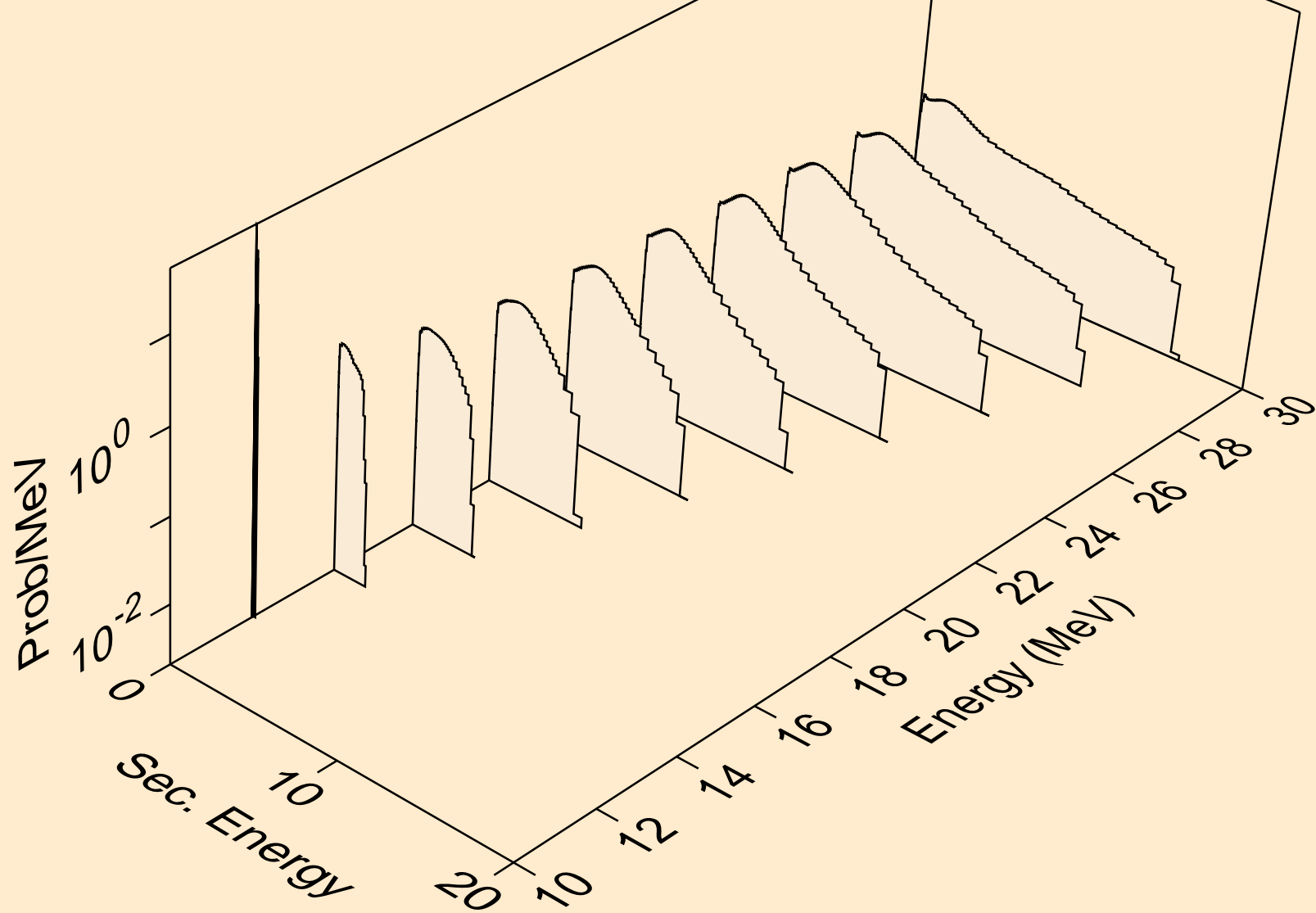

K042 ALPHA ACER TENDL-2024 LIBRARY; T=0.K  
neutrons from (a,3n)

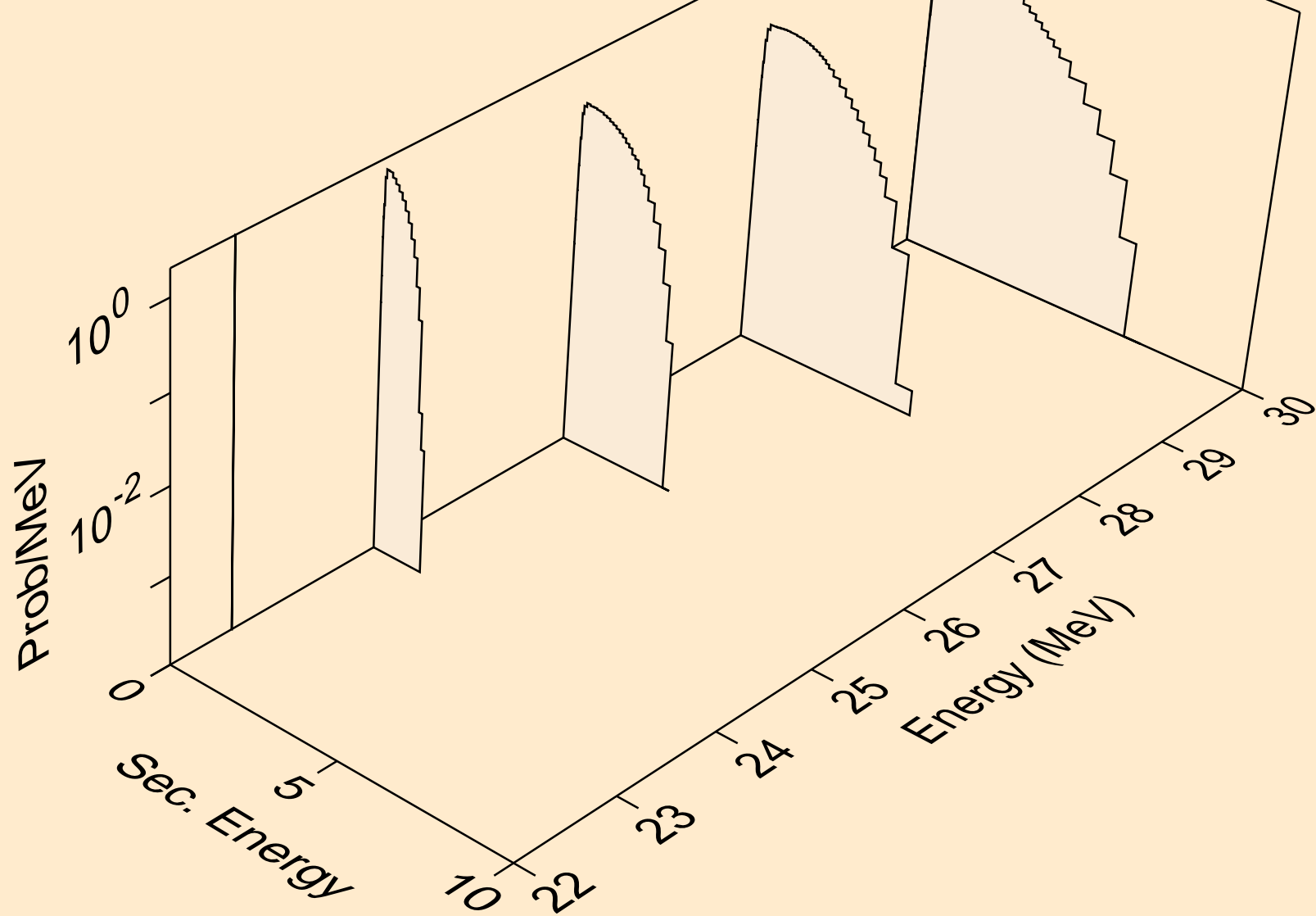

K042 ALPHA ACER TENDL-2024 LIBRARY; T=0.K  
neutrons from (a,n\*)a

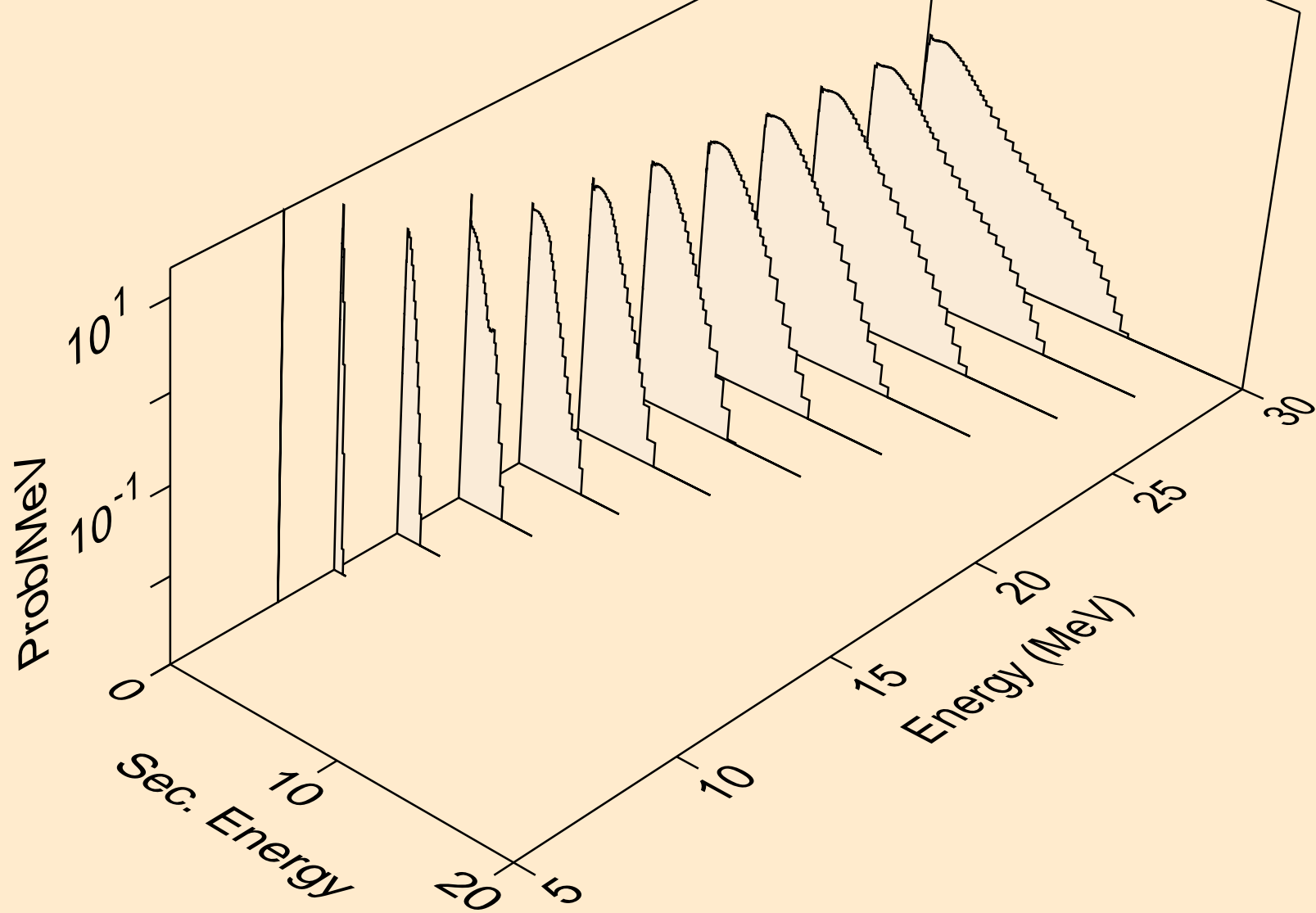

K042 ALPHA ACER TENDL-2024 LIBRARY; T=0.K  
neutrons from (a,2n)a

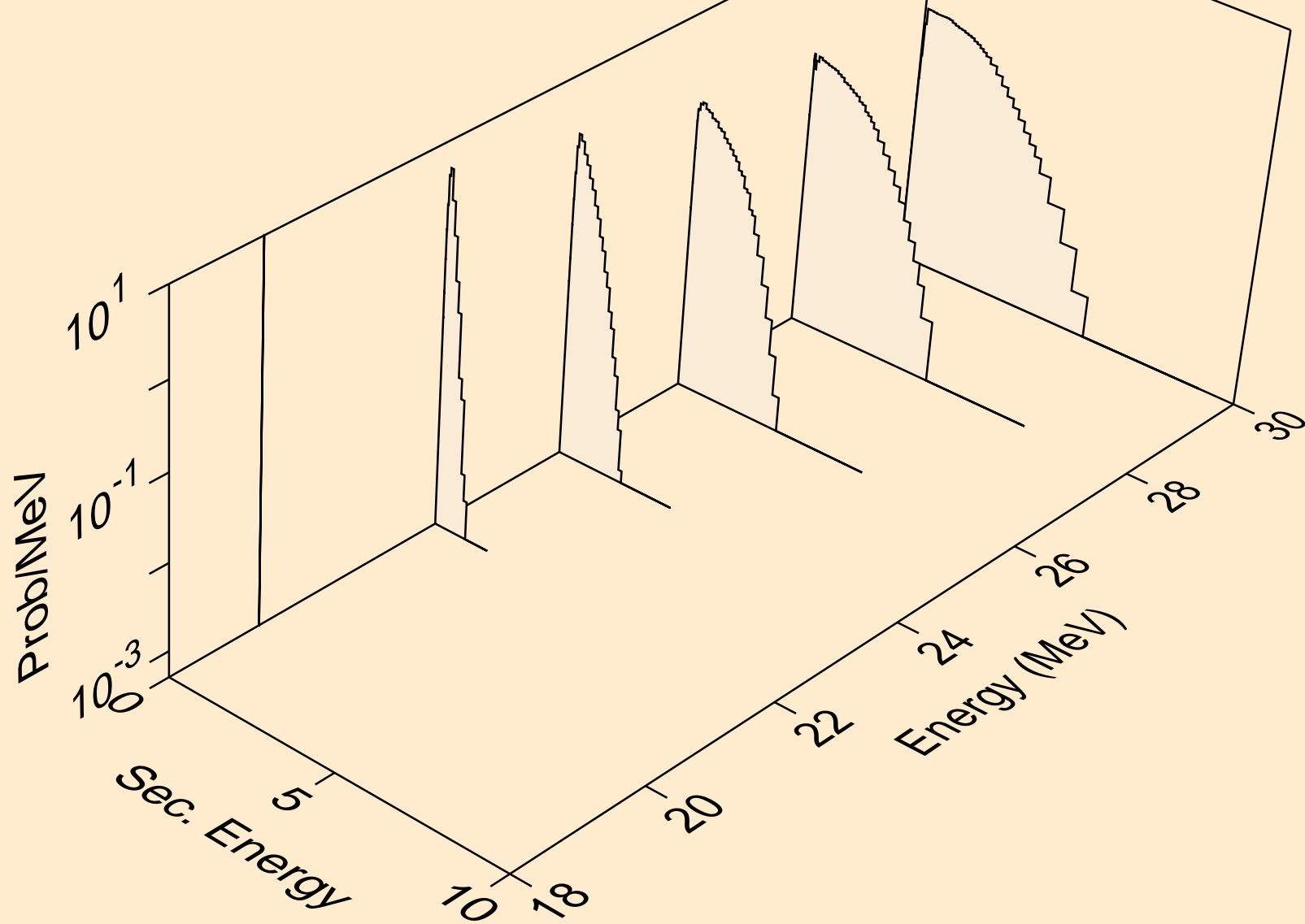

K042 ALPHA ACER TENDL-2024 LIBRARY; T=0.K  
neutrons from (a,n\*)p

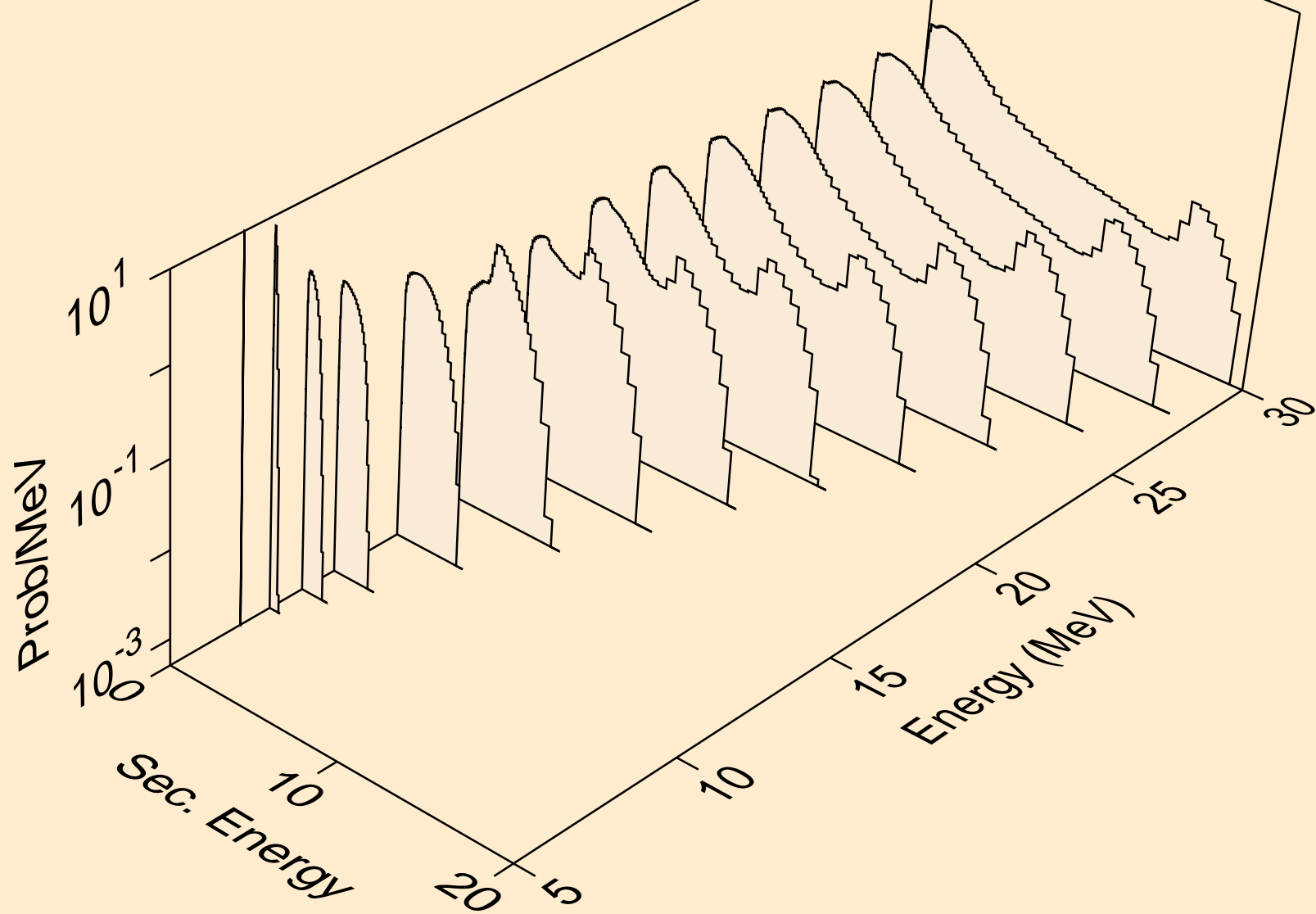

K042 ALPHA ACER TENDL-2024 LIBRARY; T=0.K  
neutrons from (a,n\*)2a

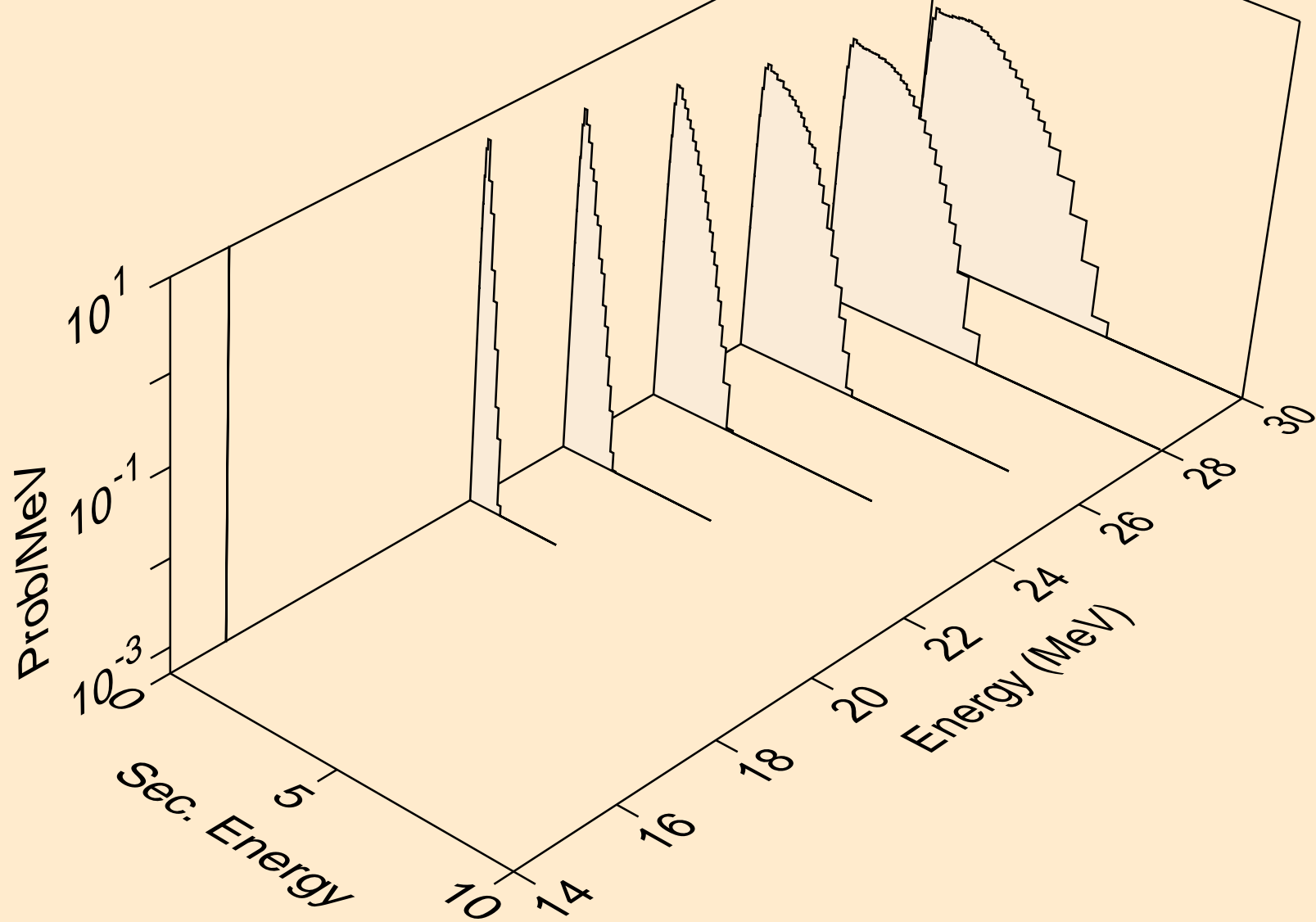

K042 ALPHA ACER TENDL-2024 LIBRARY; T=0.K  
neutrons from (a,n\*)d

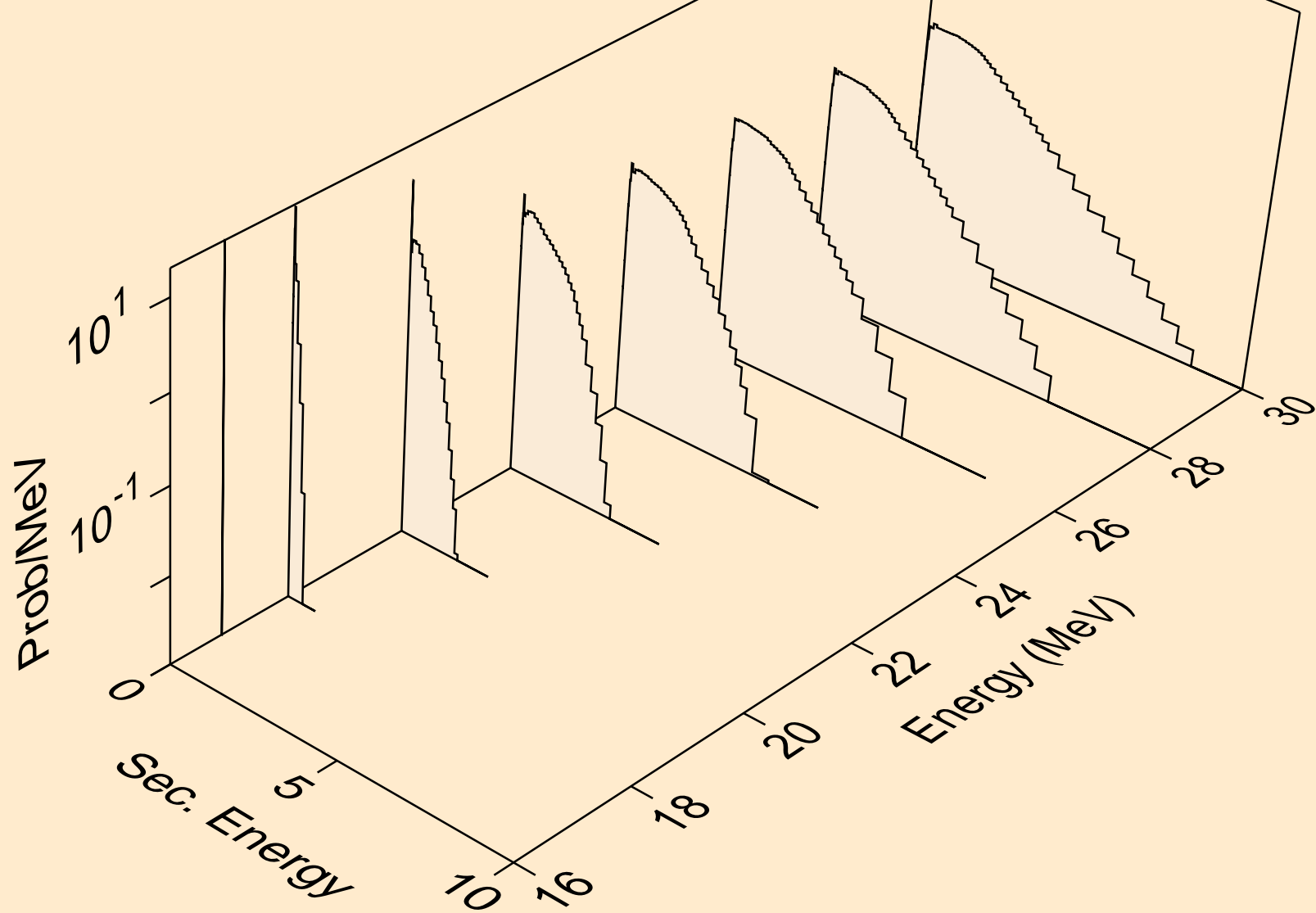

K042 ALPHA ACER TENDL-2024 LIBRARY; T=0.K  
neutrons from (a,n\*)t

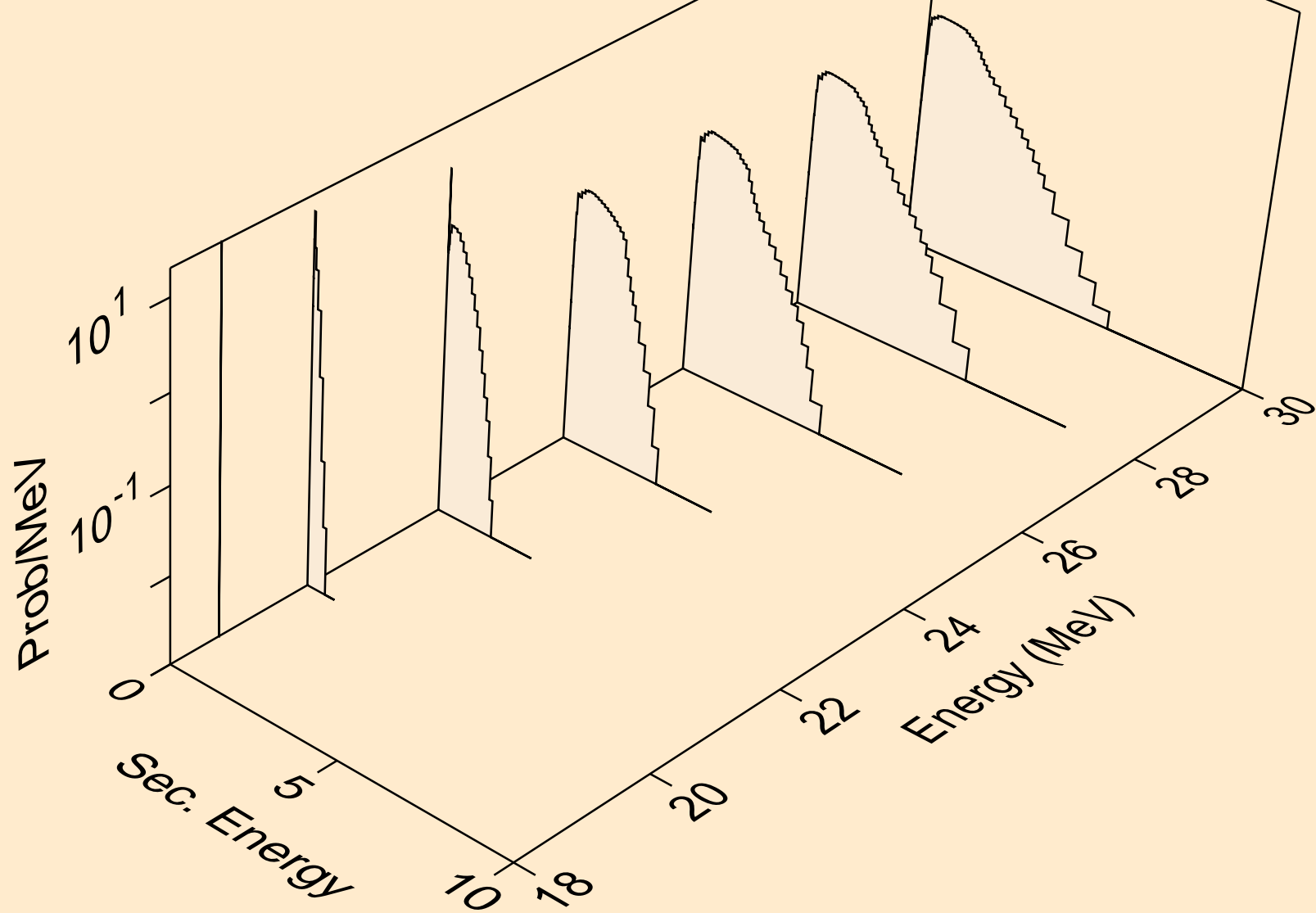

K042 ALPHA ACER TENDL-2024 LIBRARY; T=0.K  
neutrons from (a,n\*)he3

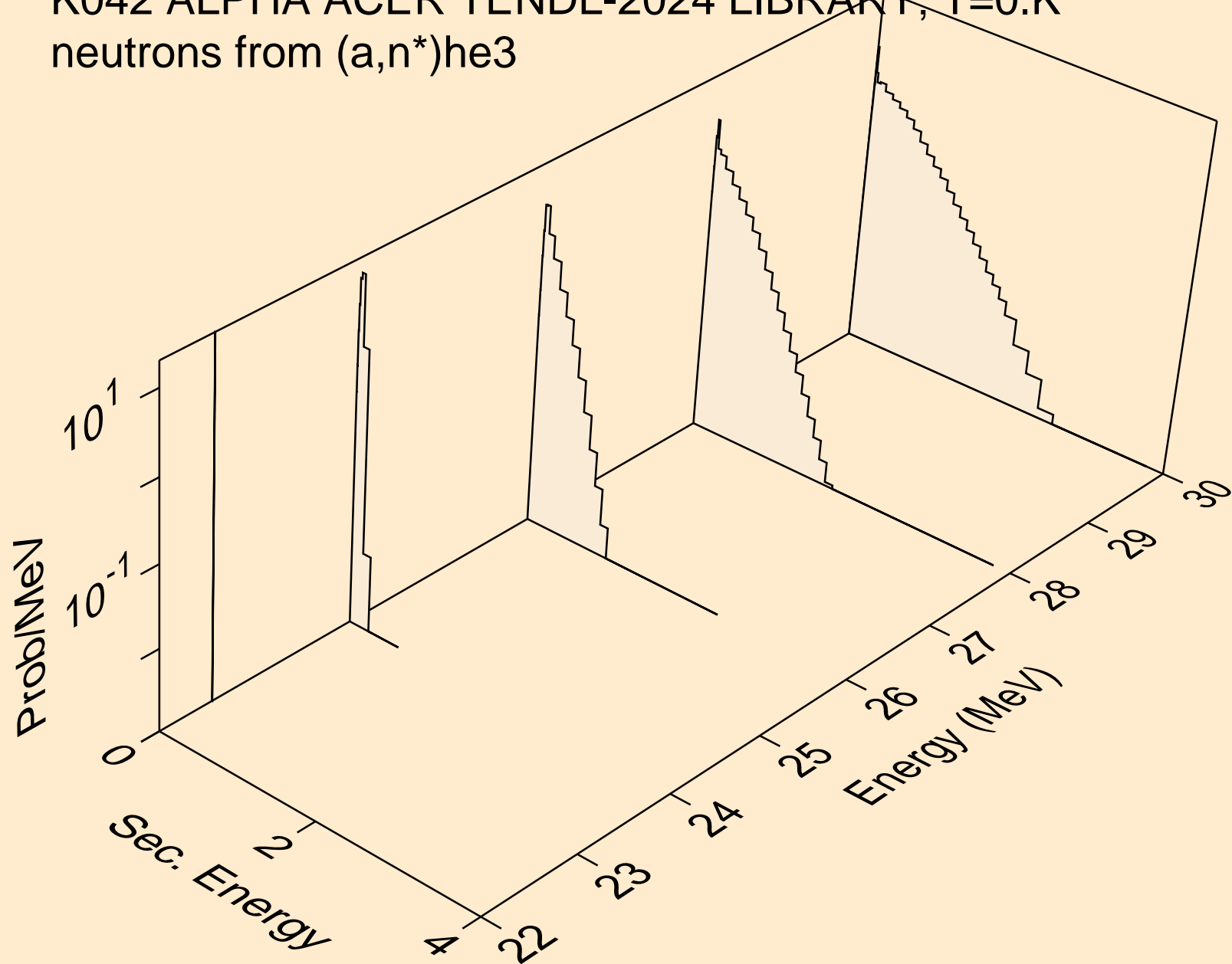

K042 ALPHA ACER TENDL-2024 LIBRARY; T=0.K  
neutrons from (a,2np)

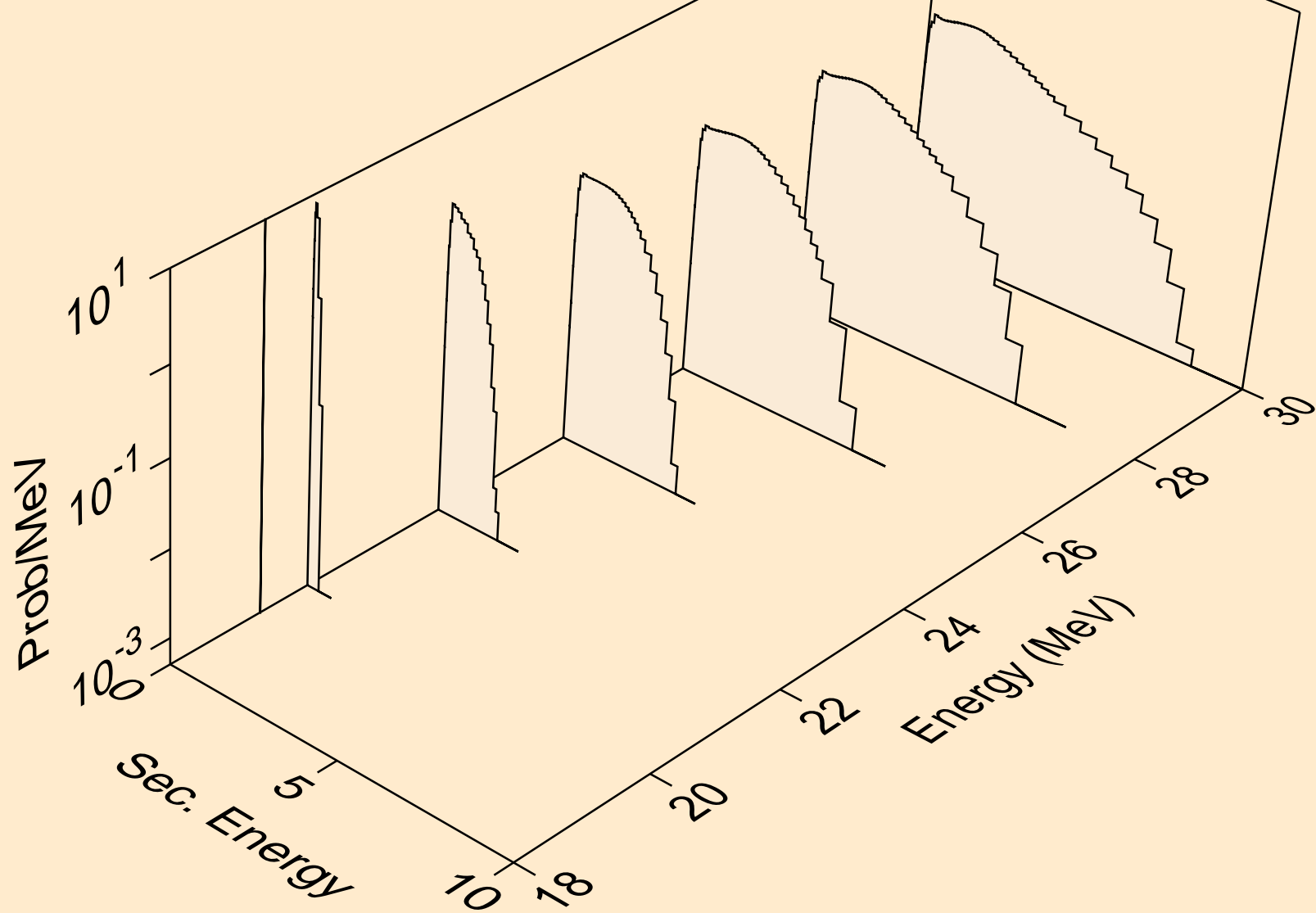

K042 ALPHA ACER TENDL-2024 LIBRARY; T=0.K  
neutrons from (a,3np)

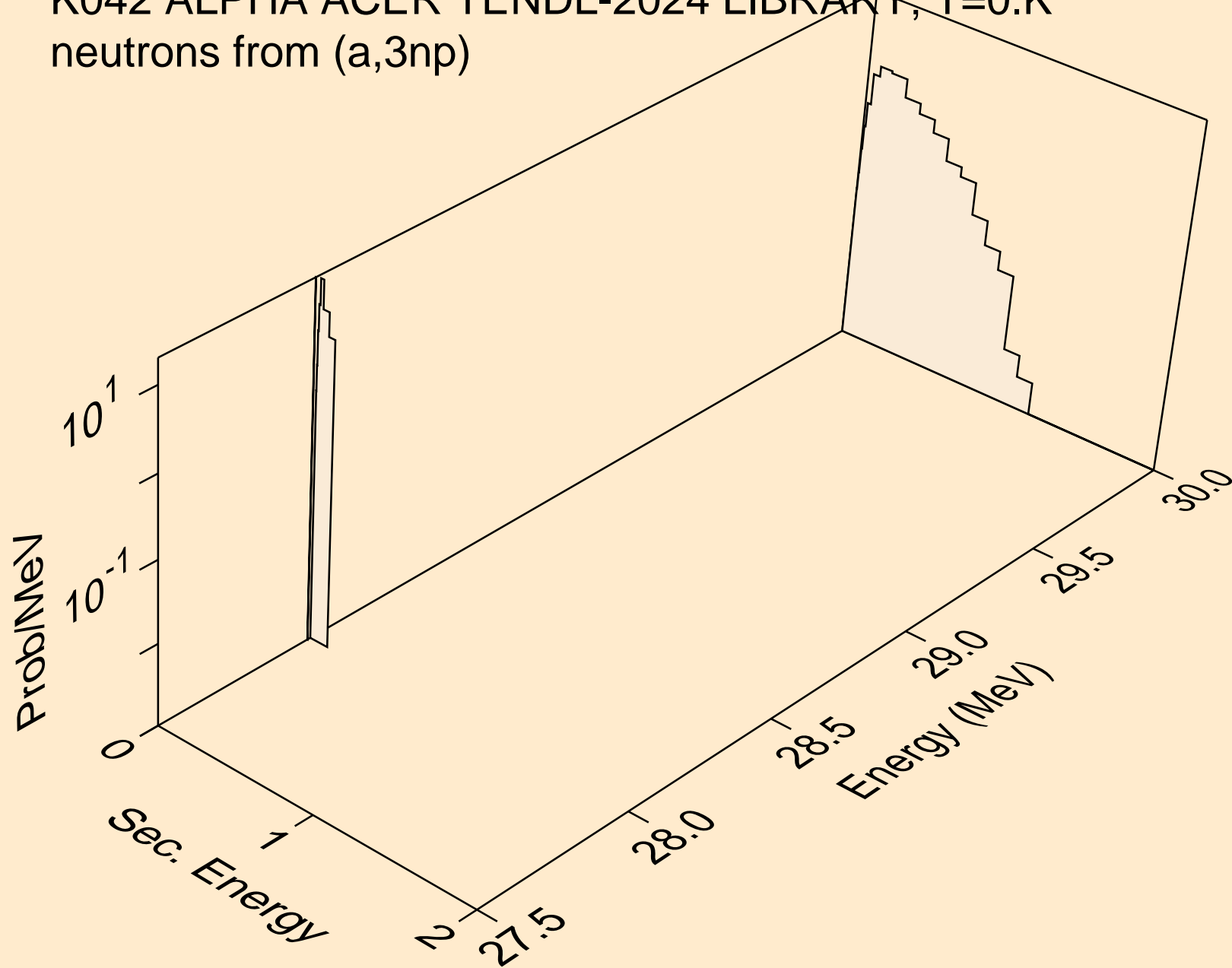

K042 ALPHA ACER TENDL-2024 LIBRARY; T=0.K  
neutrons from (a,n2p)

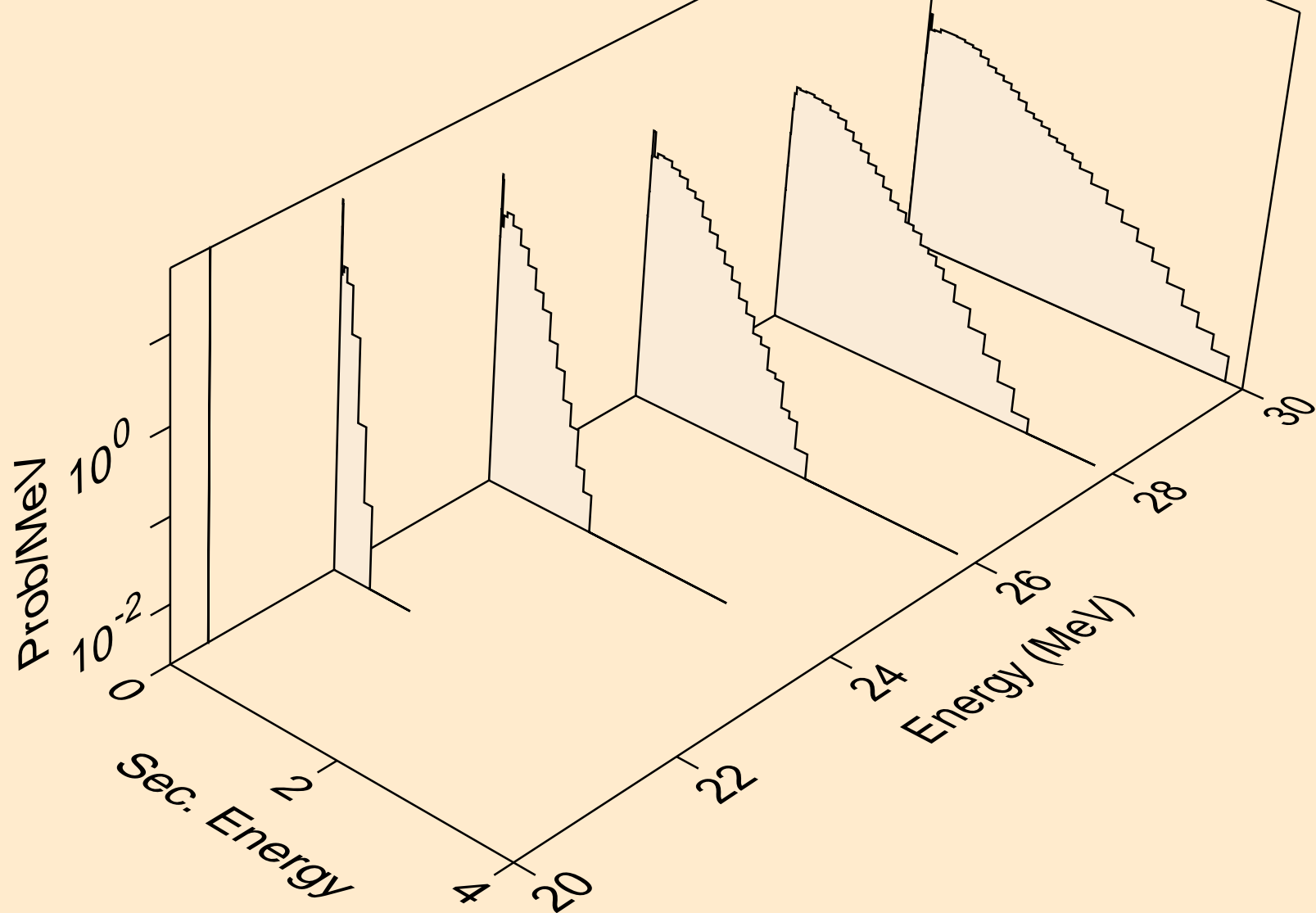

K042 ALPHA ACER TENDL-2024 LIBRARY; T=0.K  
neutrons from (a,npa)

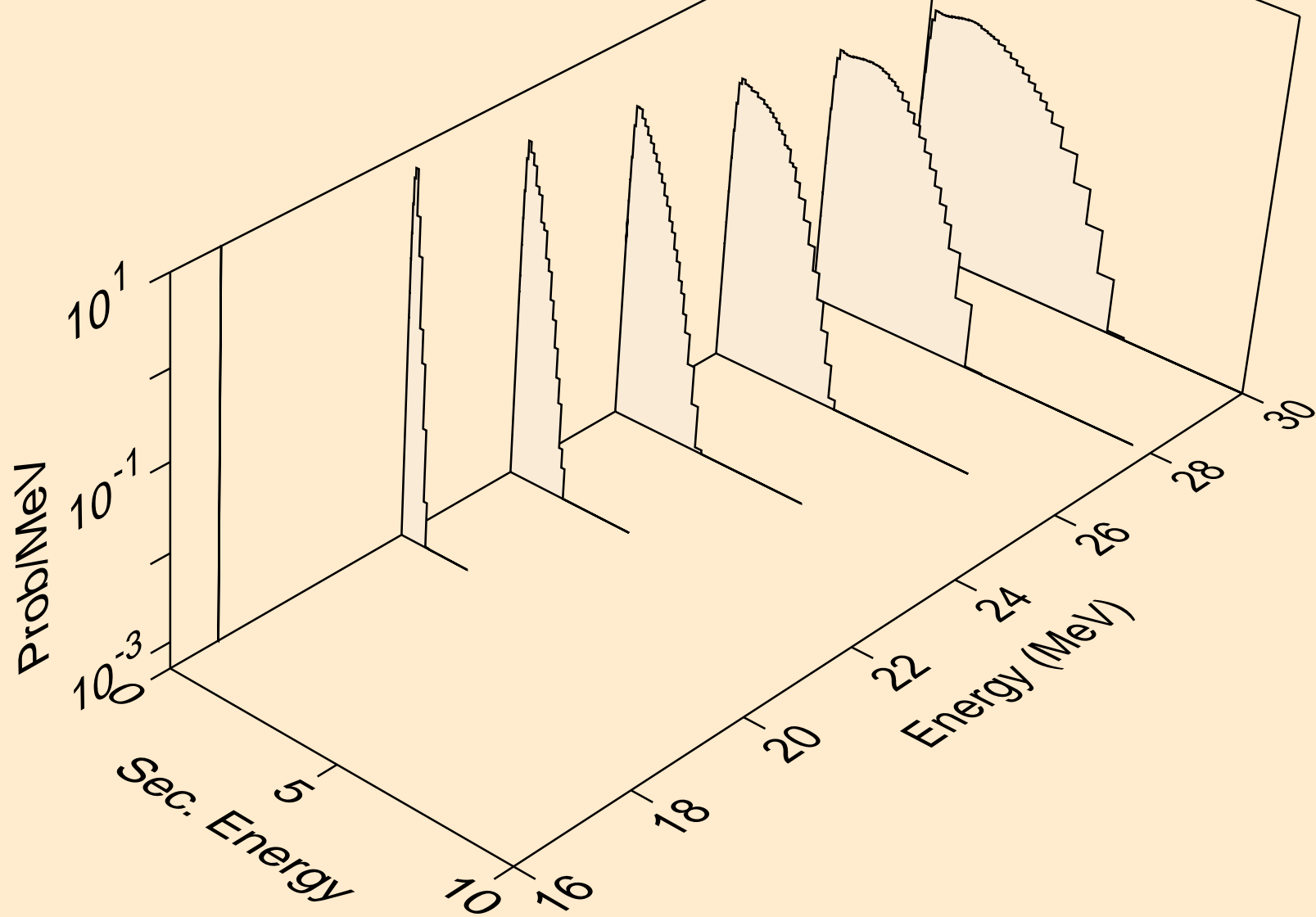

K042 ALPHA ACER TENDL-2024 LIBRARY; T=0.K  
protons from (a,x)

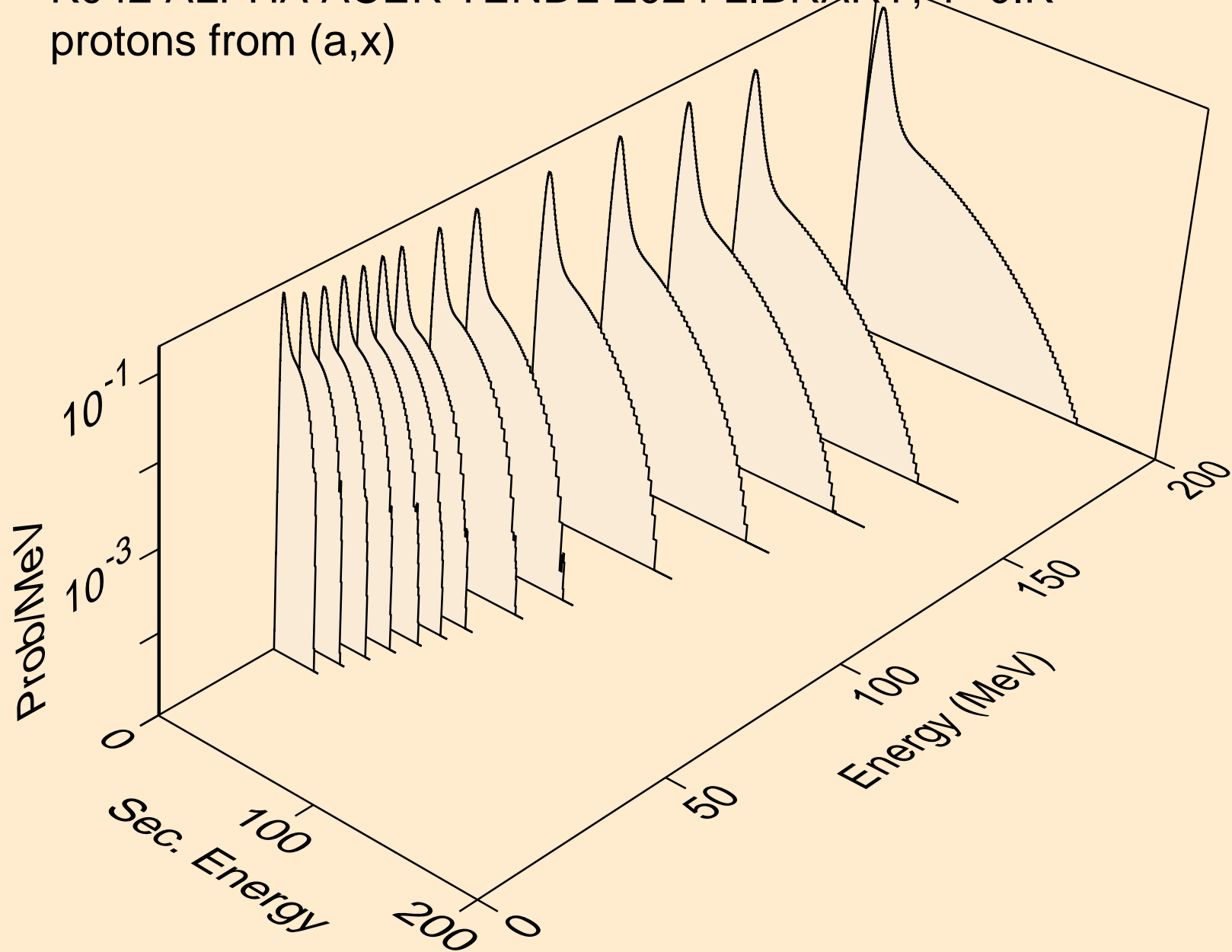

K042 ALPHA ACER TENDL-2024 LIBRARY; T=0.K  
protons from (a,n\*)p

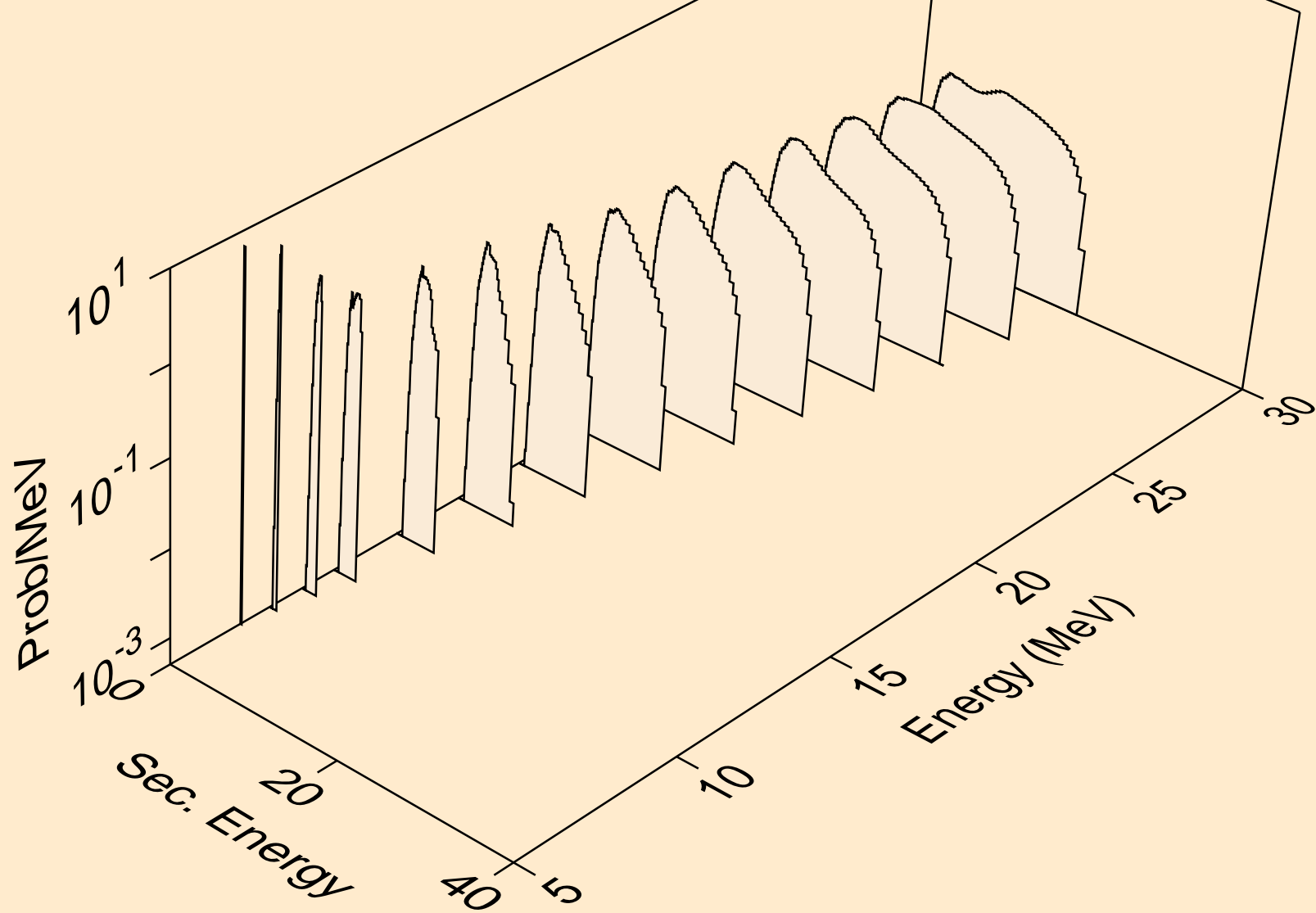

K042 ALPHA ACER TENDL-2024 LIBRARY; T=0.K  
protons from (a,2np)

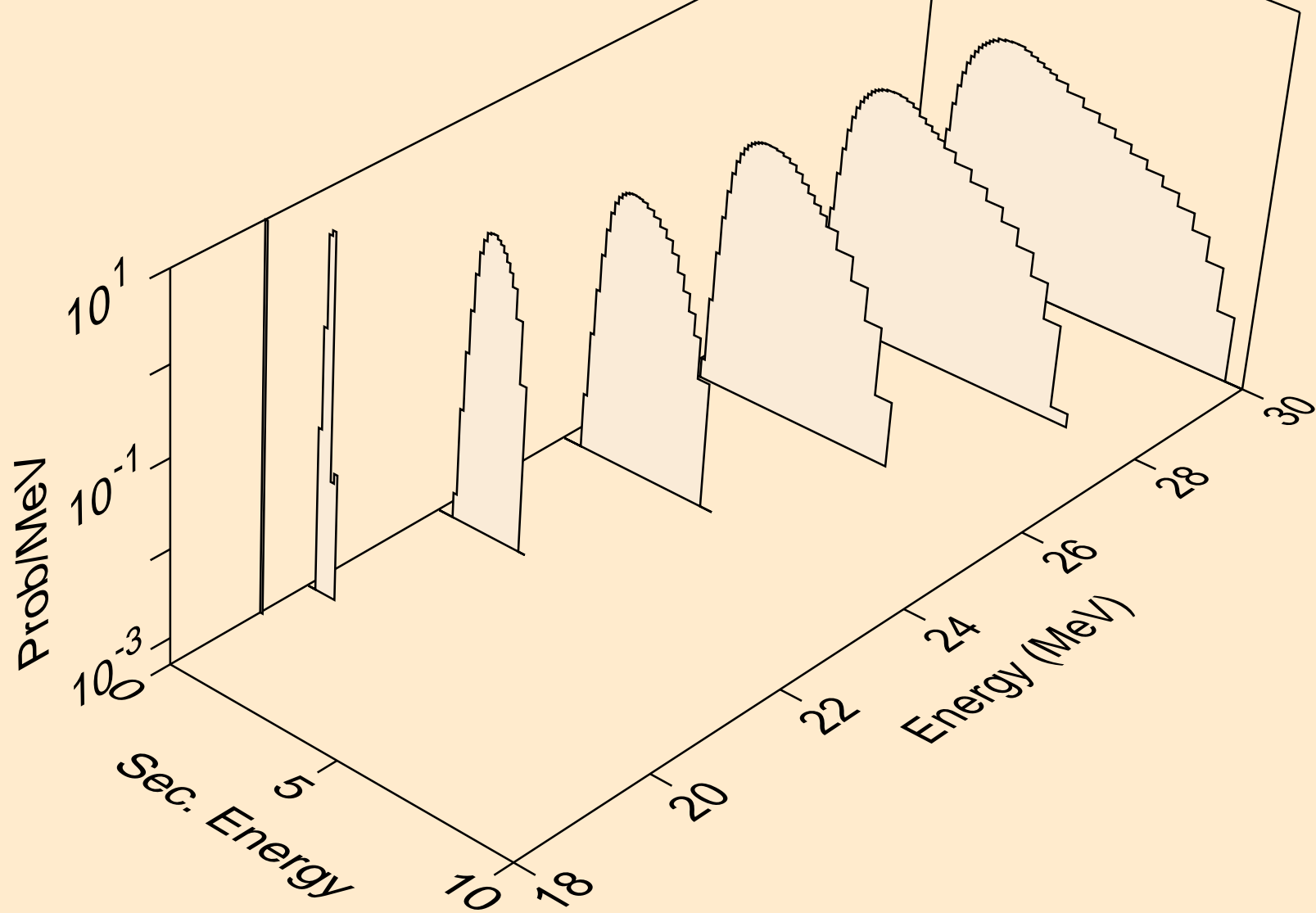

K042 ALPHA ACER TENDL-2024 LIBRARY; T=0.K  
protons from (a,3np)

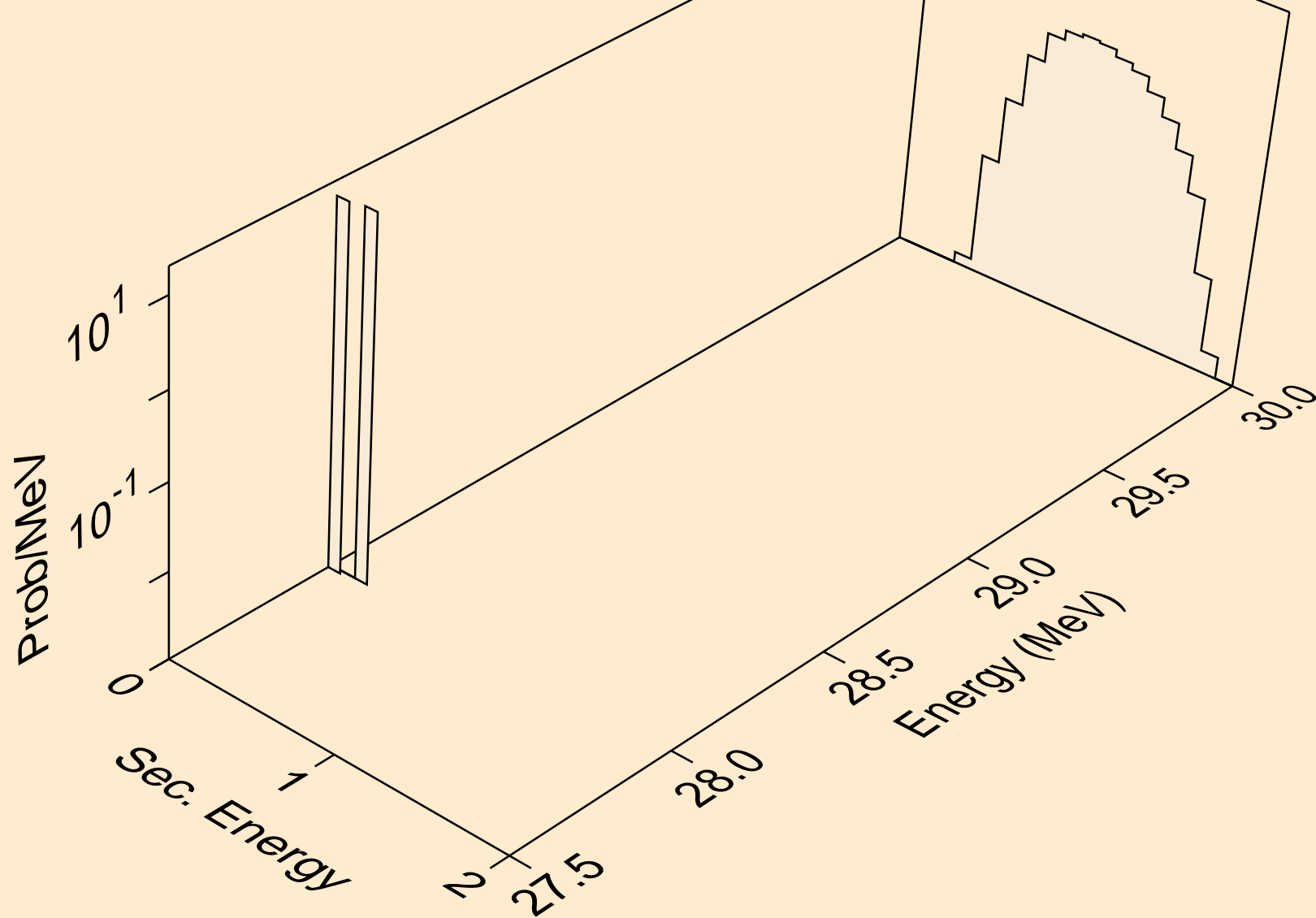

K042 ALPHA ACER TENDL-2024 LIBRARY; T=0.K  
protons from (a,n2p)

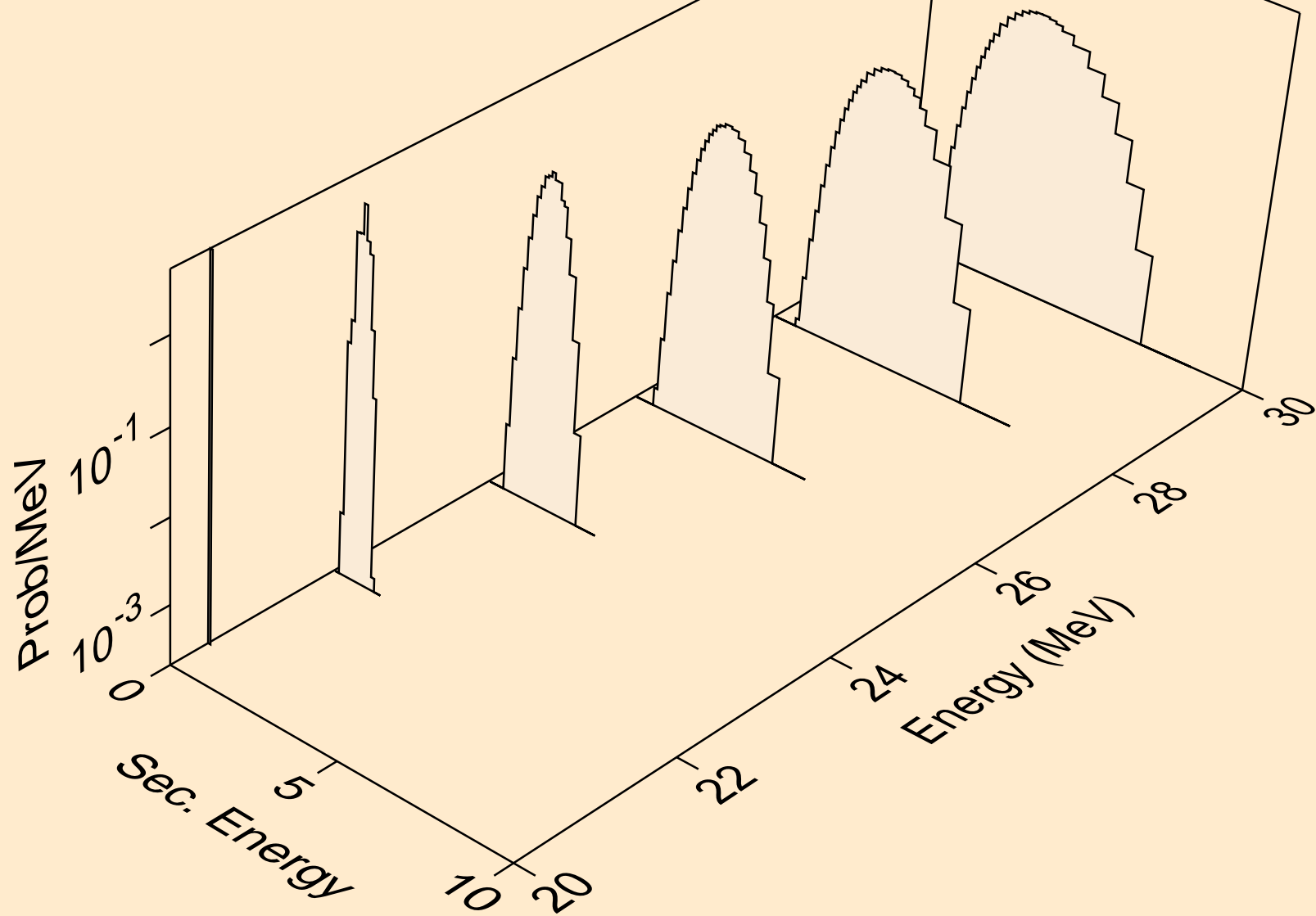

K042 ALPHA ACER TENDL-2024 LIBRARY; T=0.K  
protons from (a,npa)

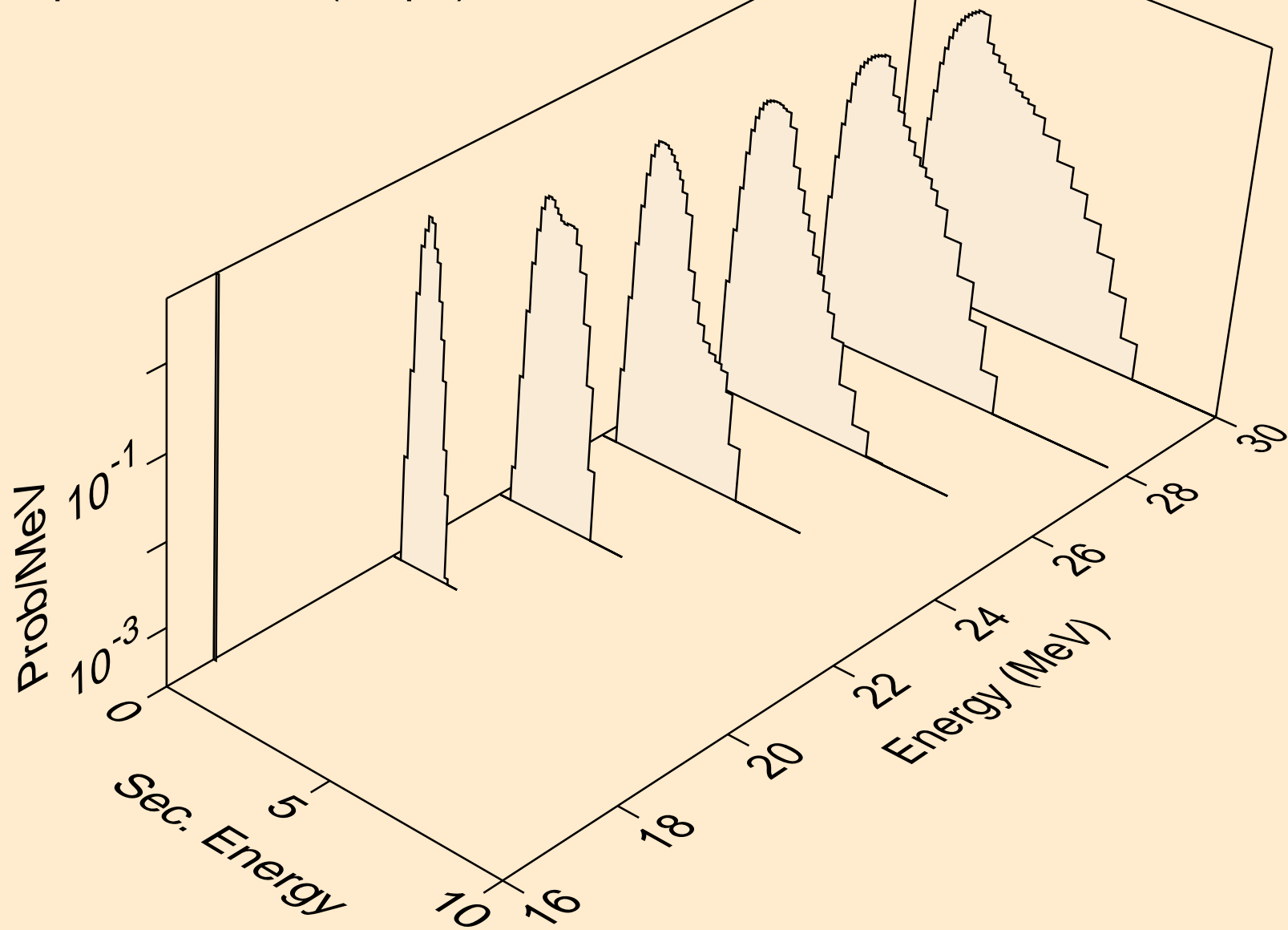

K042 ALPHA ACER TENDL-2024 LIBRARY; T=0.K  
protons from (a,p)

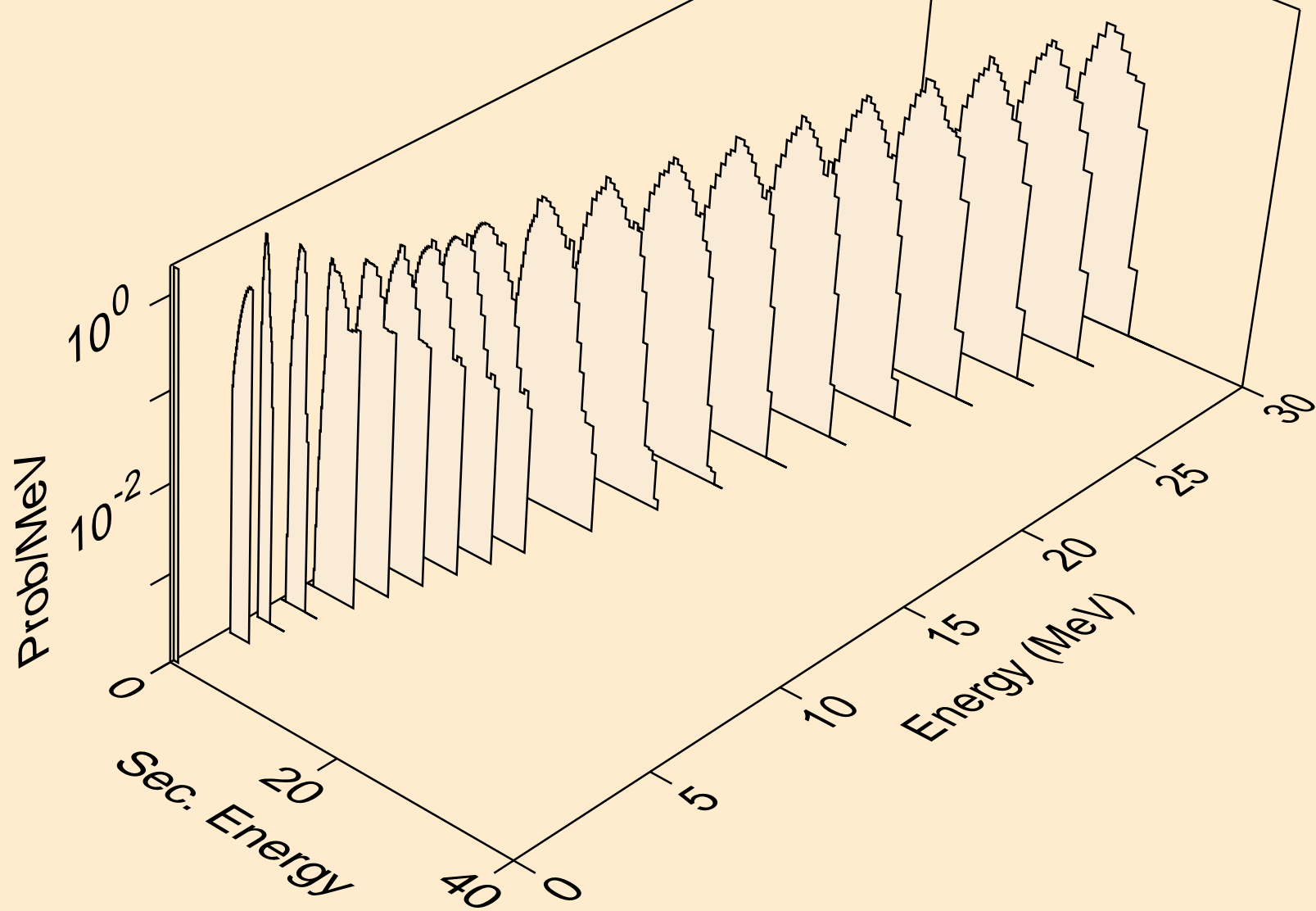

K042 ALPHA ACER TENDL-2024 LIBRARY; T=0.K  
protons from (a,2p)

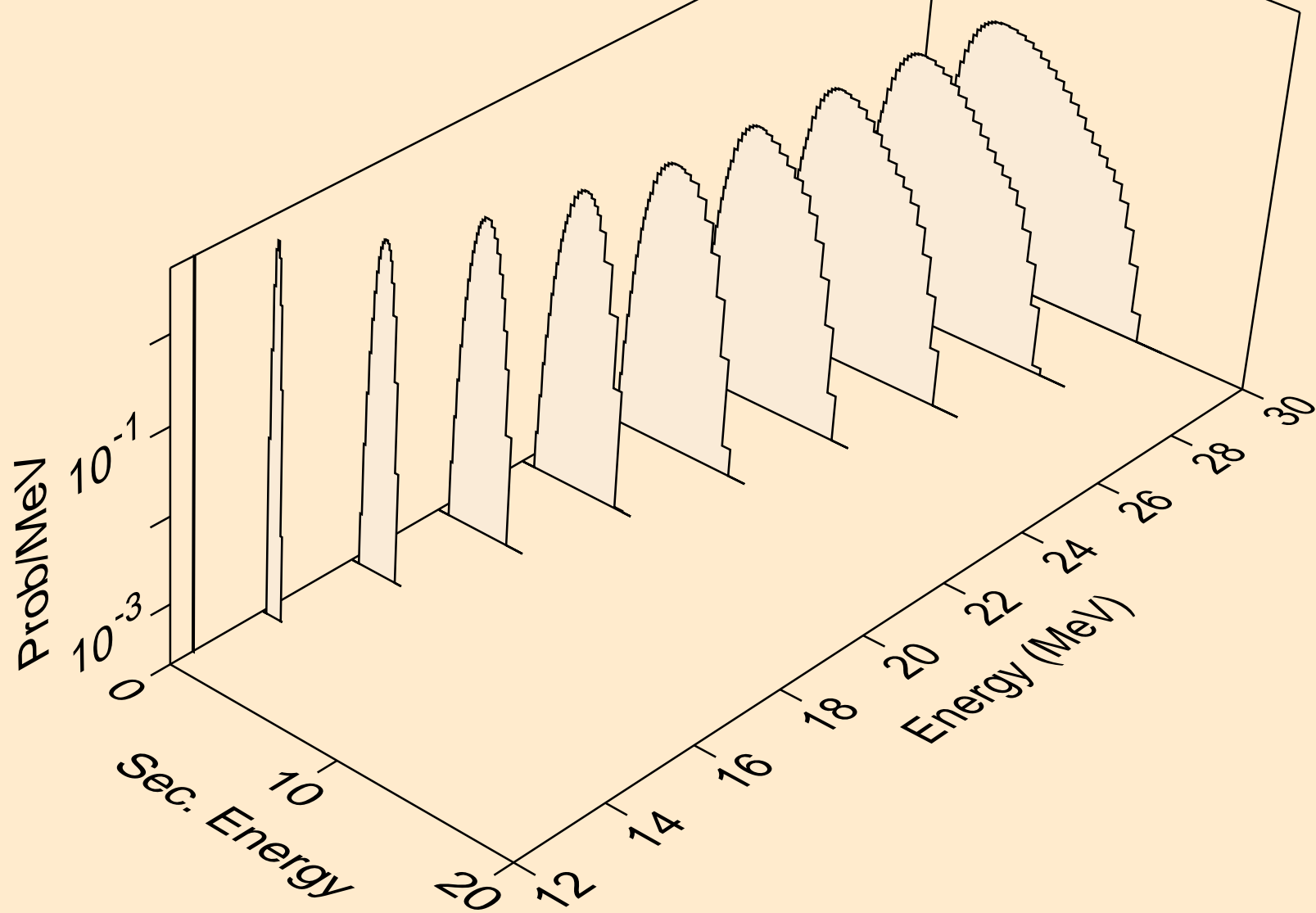

K042 ALPHA ACER TENDL-2024 LIBRARY; T=0.K  
protons from (a,pa)

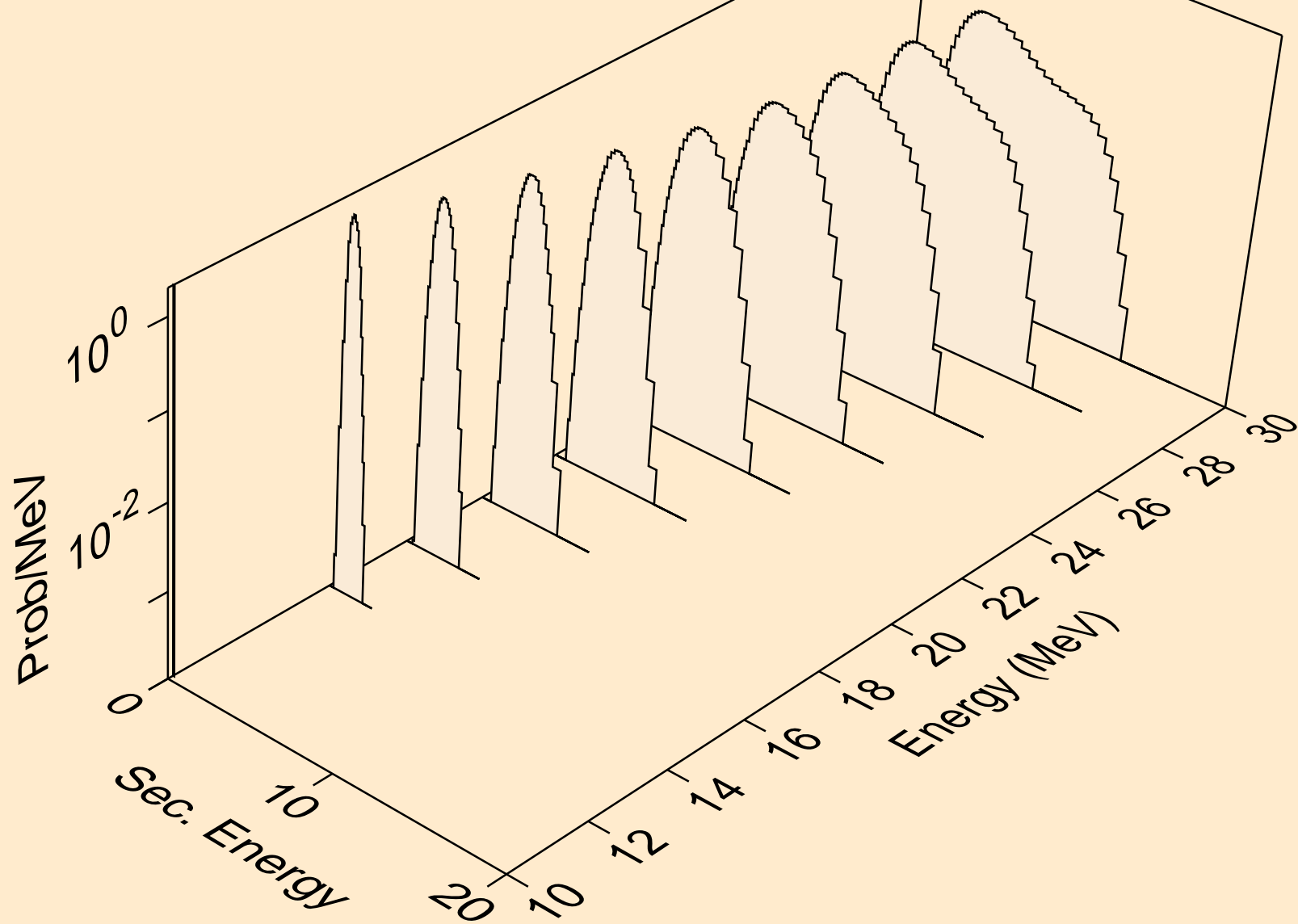

K042 ALPHA ACER TENDL-2024 LIBRARY; T=0.K  
protons from (a,pd)

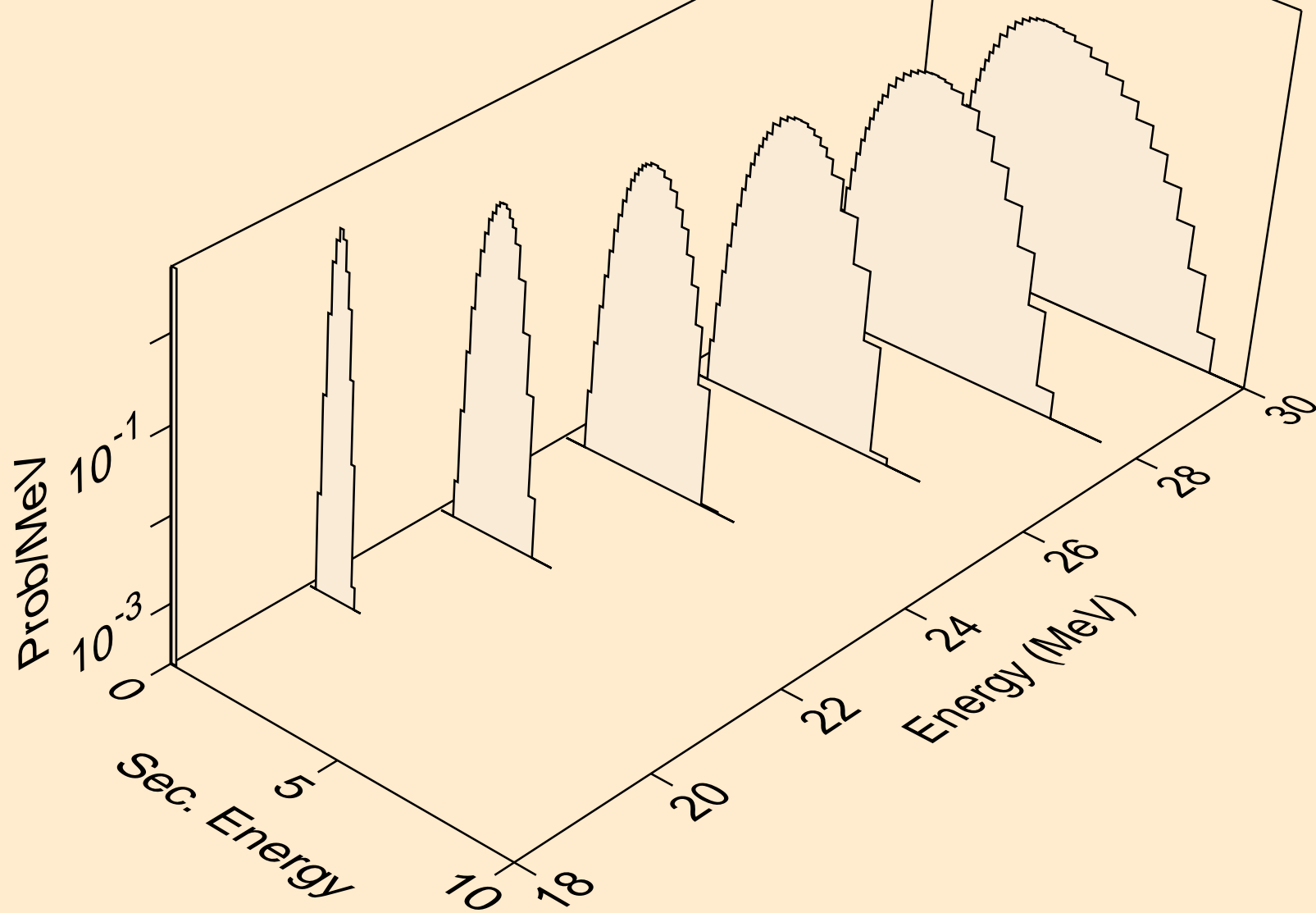

K042 ALPHA ACER TENDL-2024 LIBRARY; T=0.K  
protons from (a,pt)

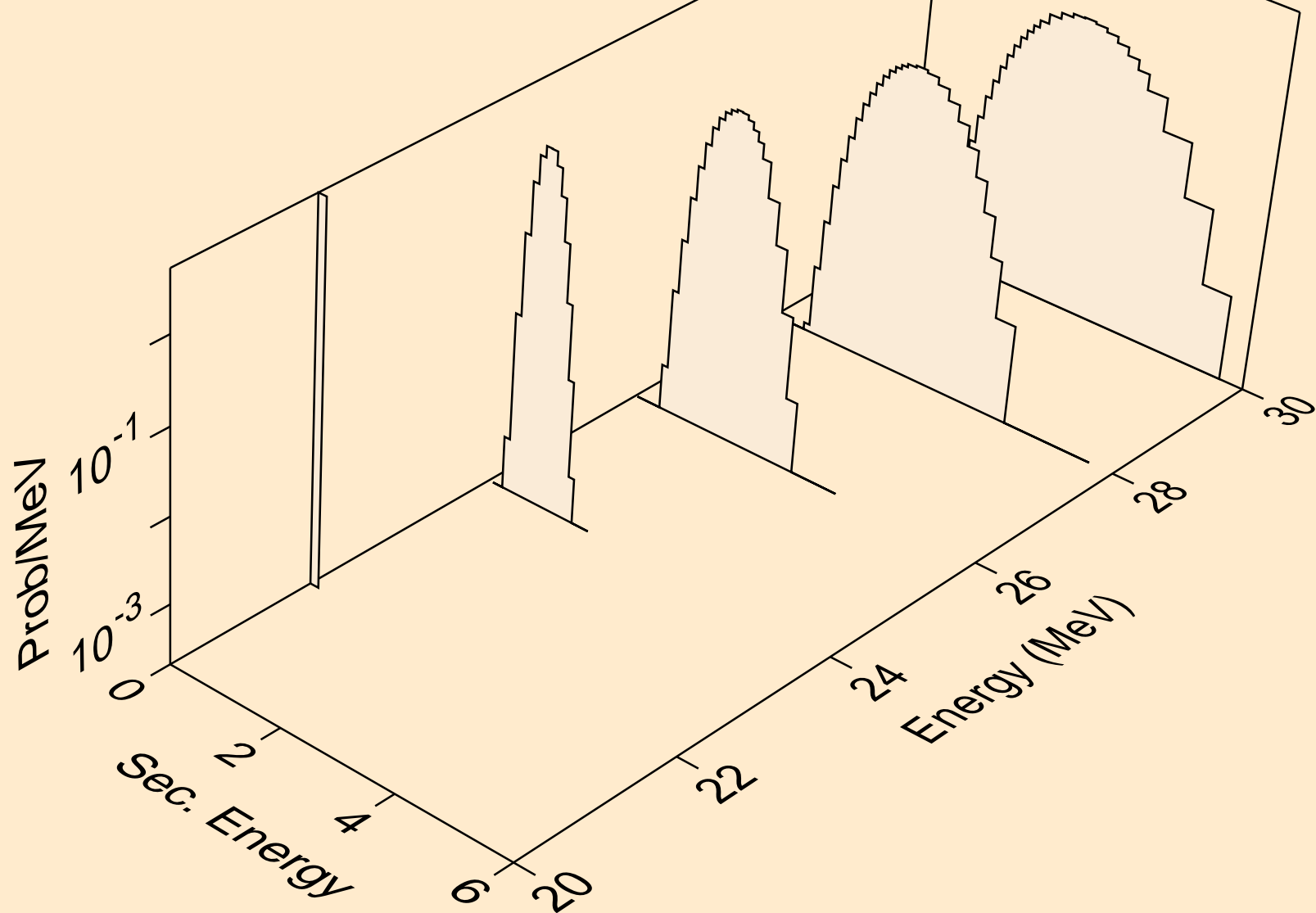

K042 ALPHA ACER TENDL-2024 LIBRARY; T=0.K  
deuterons from (a,x)

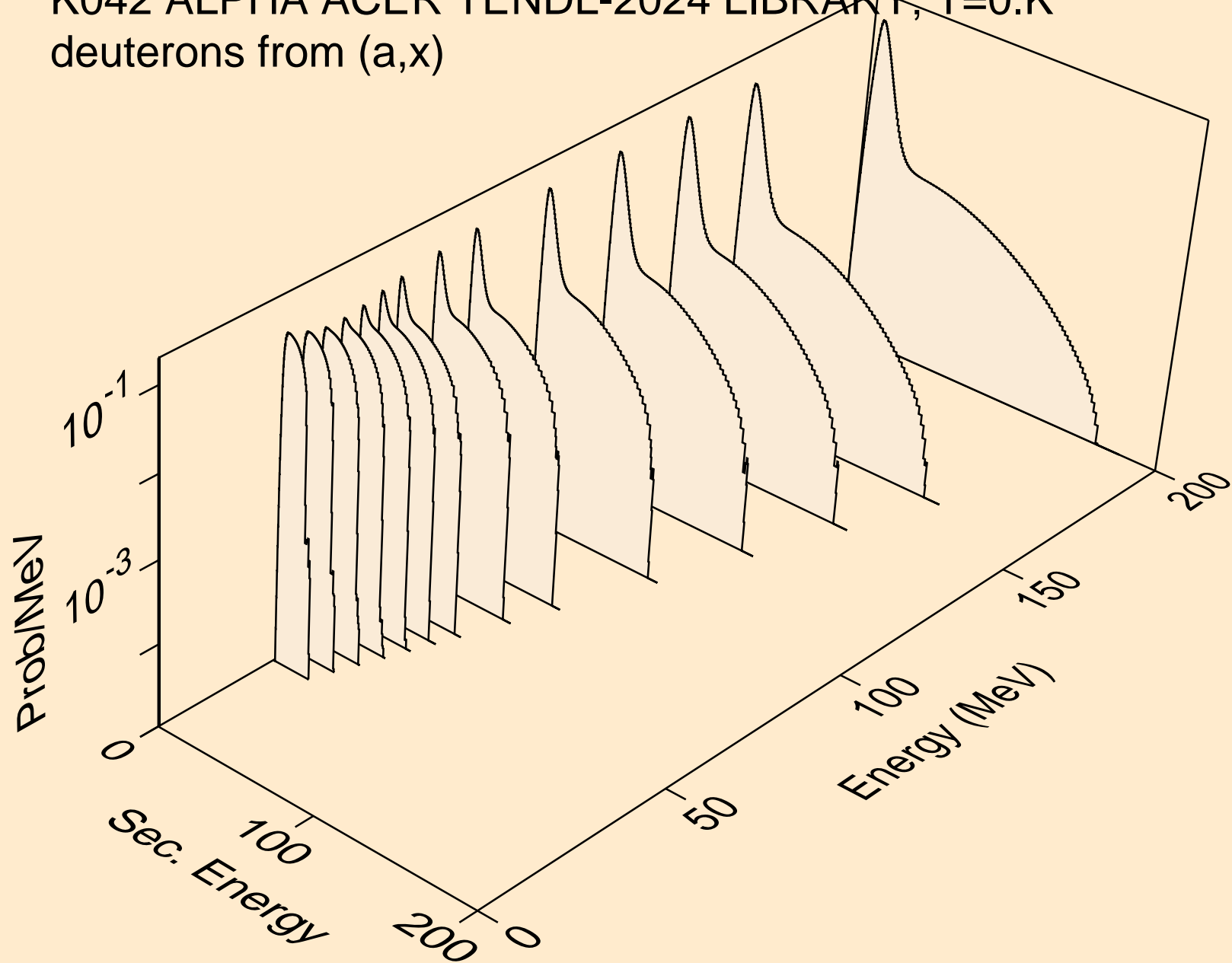

K042 ALPHA ACER TENDL-2024 LIBRARY; T=0.K  
deuterons from (a,2nd)

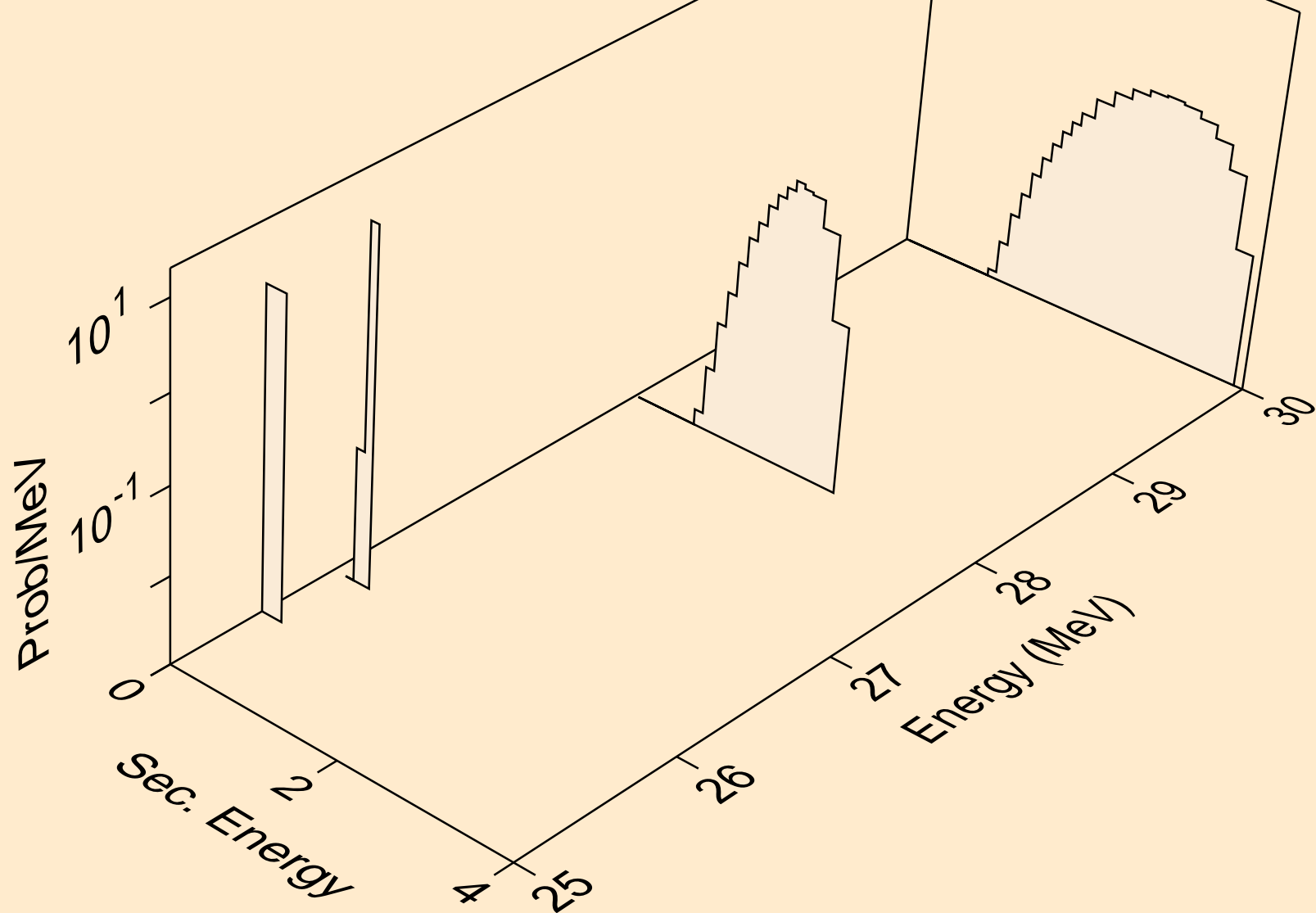

K042 ALPHA ACER TENDL-2024 LIBRARY; T=0.K  
deuterons from (a,n\*)d

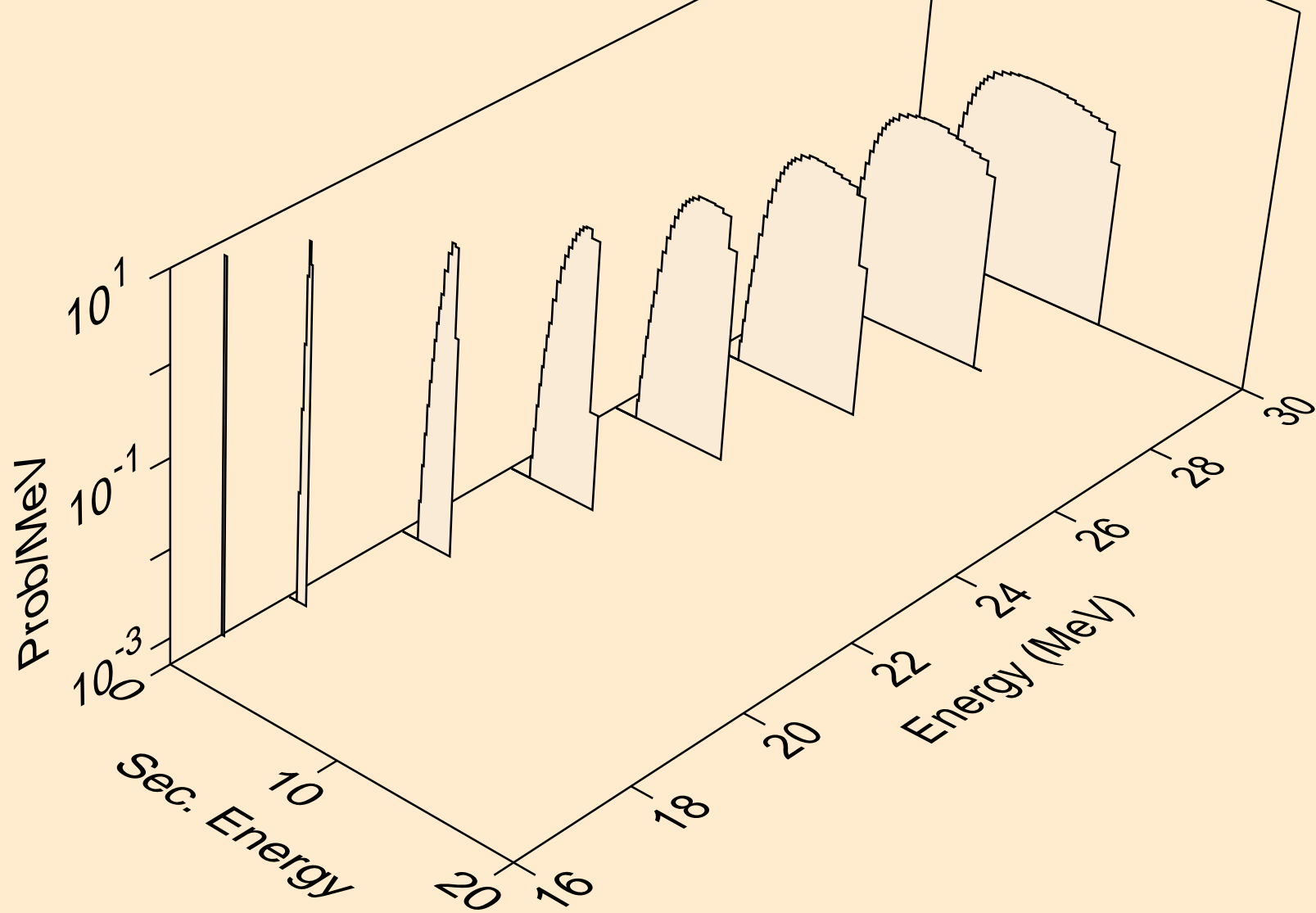

K042 ALPHA ACER TENDL-2024 LIBRARY; T=0.K  
deuterons from (a,d)

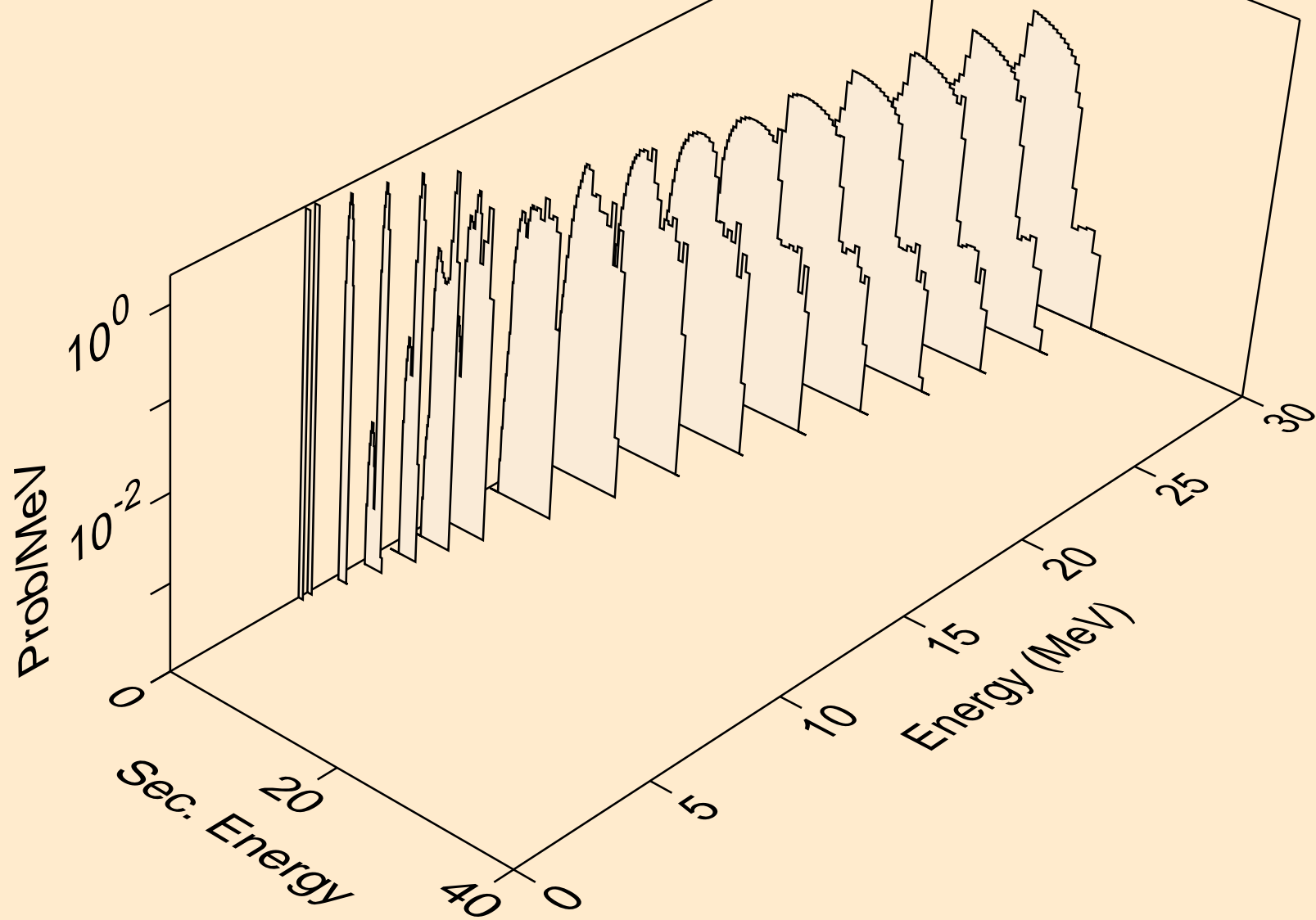

K042 ALPHA ACER TENDL-2024 LIBRARY; T=0.K  
deuterons from (a,pd)

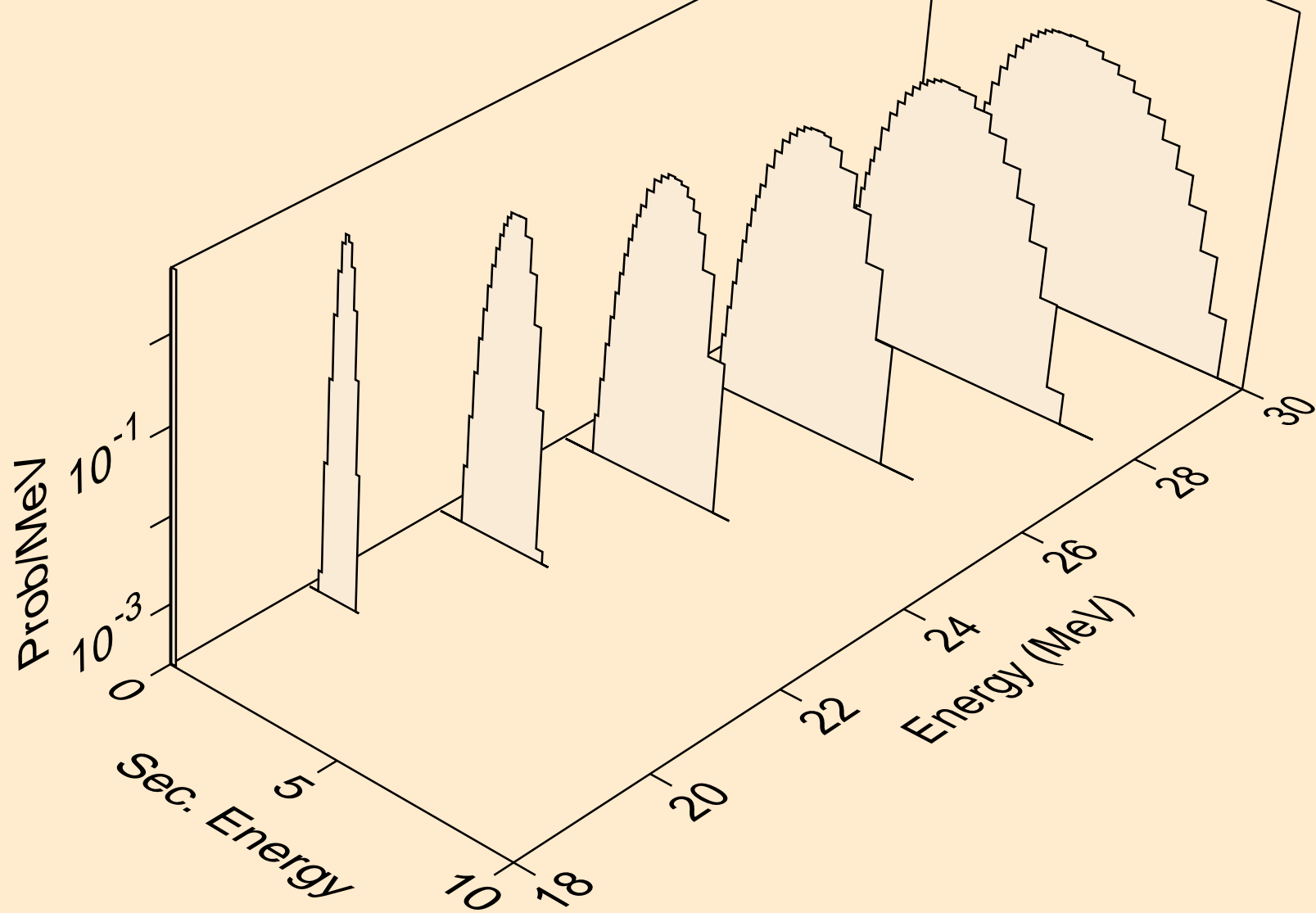

K042 ALPHA ACER TENDL-2024 LIBRARY; T=0.K  
deuterons from (a,da)

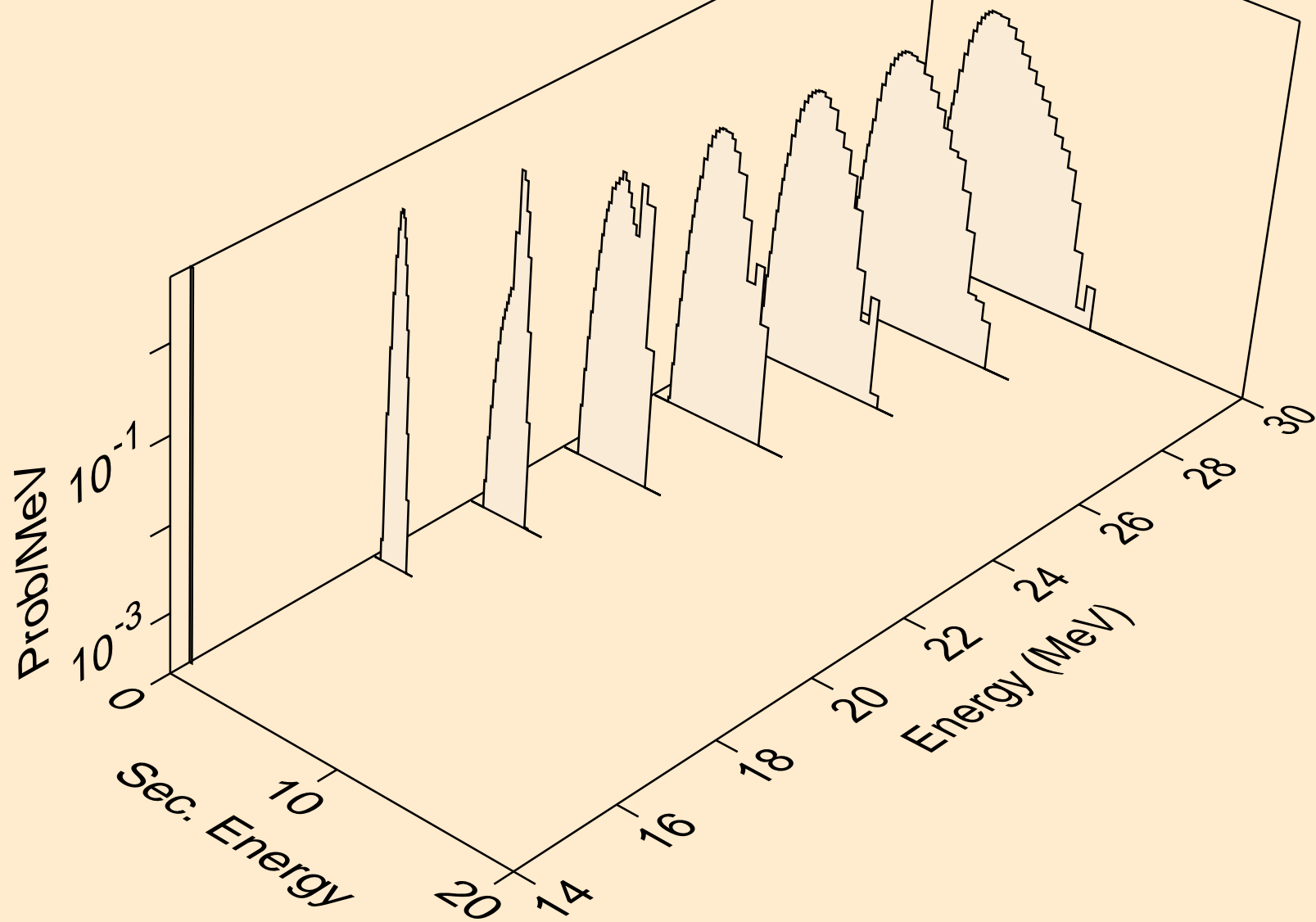

K042 ALPHA ACER TENDL-2024 LIBRARY; T=0.K  
tritons from (a,x)

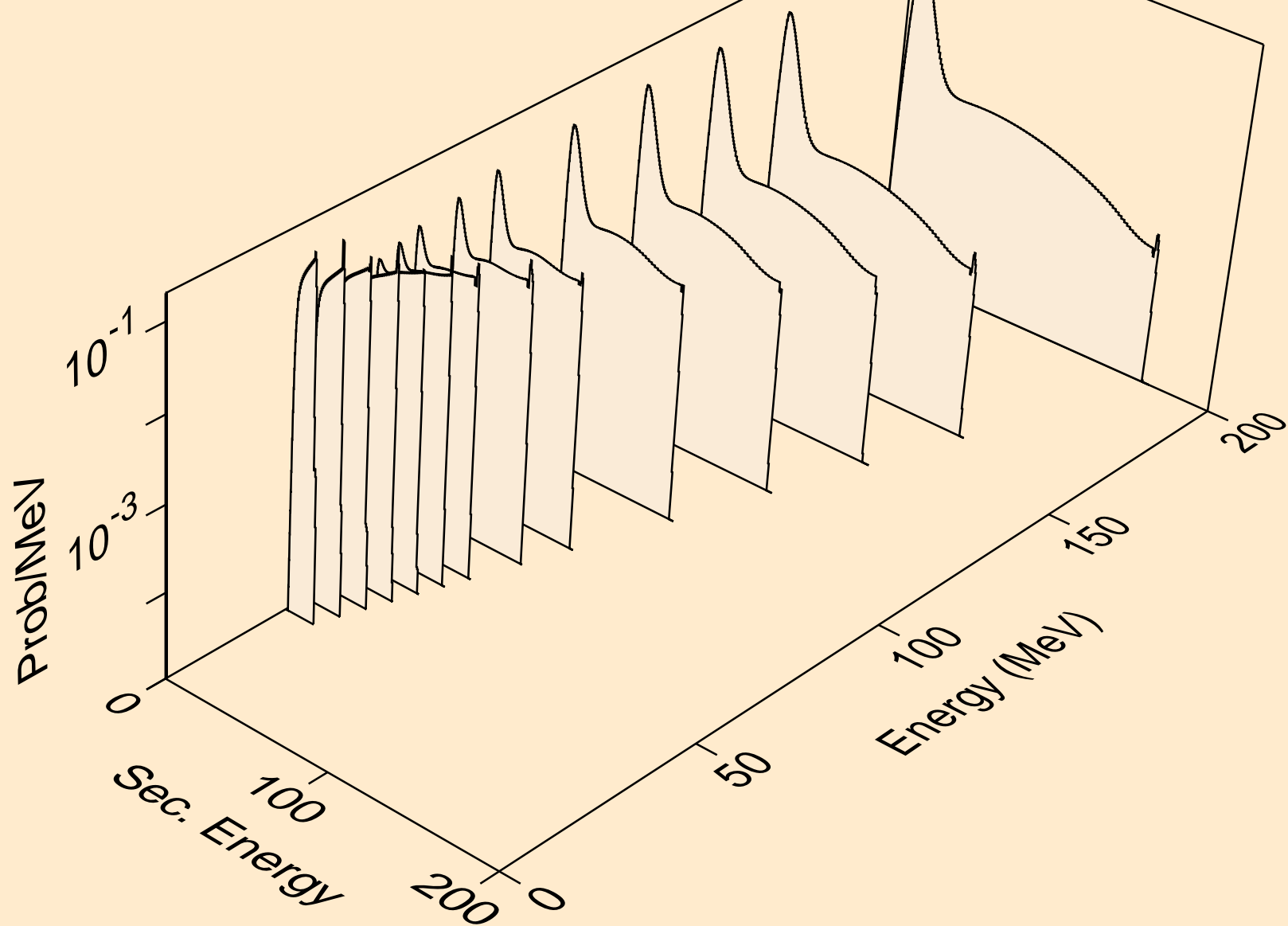

K042 ALPHA ACER TENDL-2024 LIBRARY; T=0.K  
tritons from (a,n\*)t

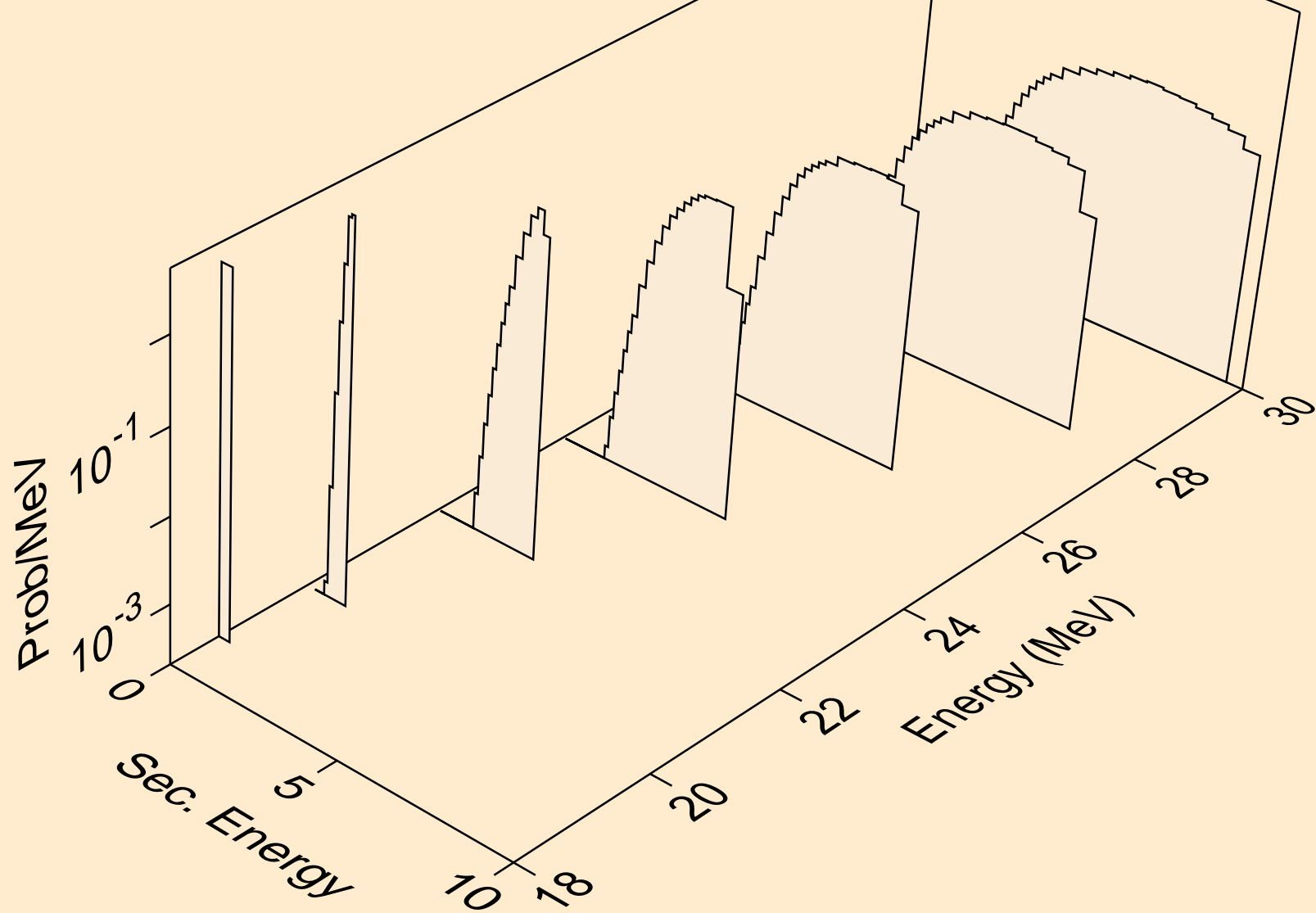

K042 ALPHA ACER TENDL-2024 LIBRARY; T=0.K  
tritons from (a,t)

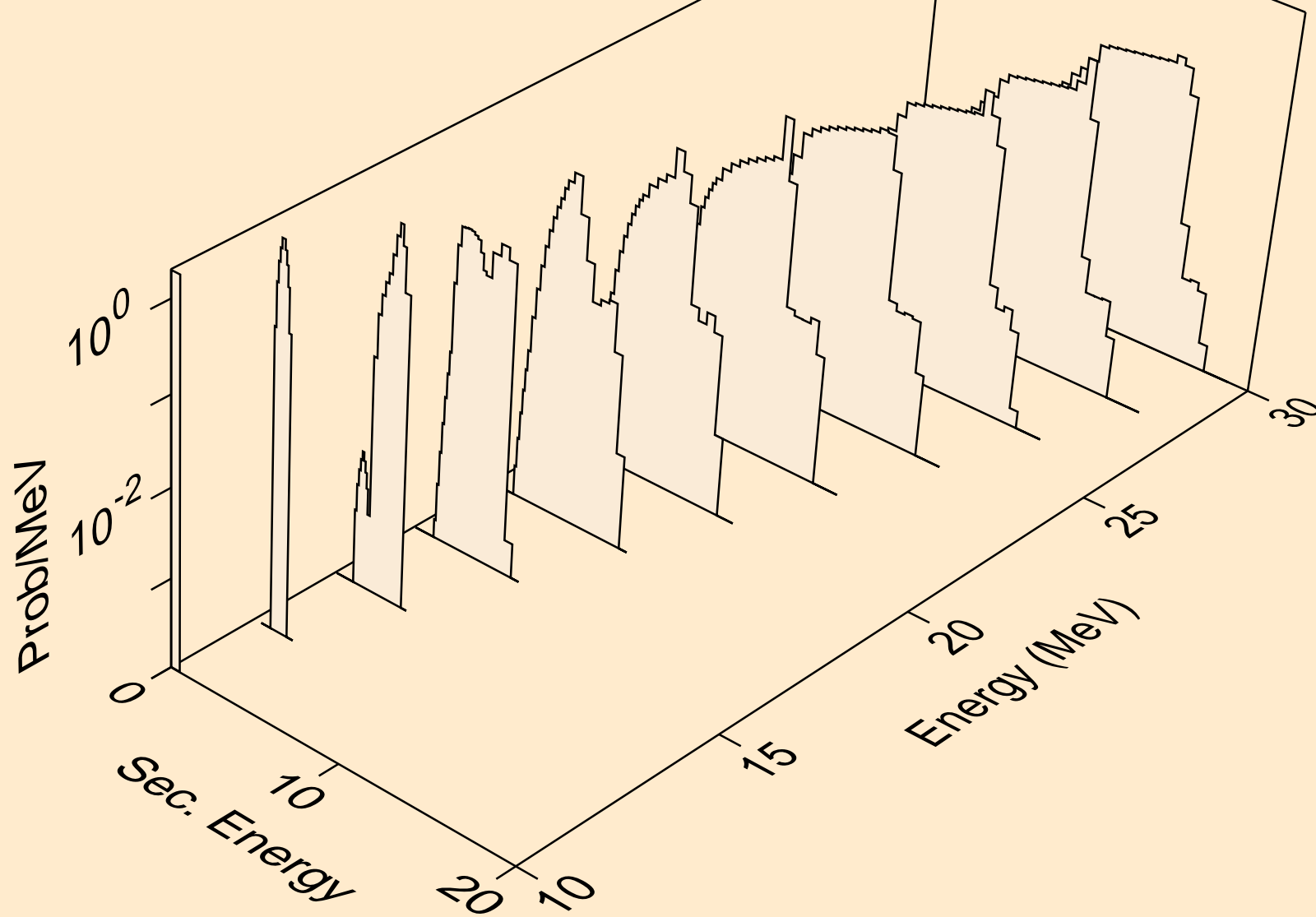

K042 ALPHA ACER TENDL-2024 LIBRARY; T=0.K  
tritons from (a,pt)

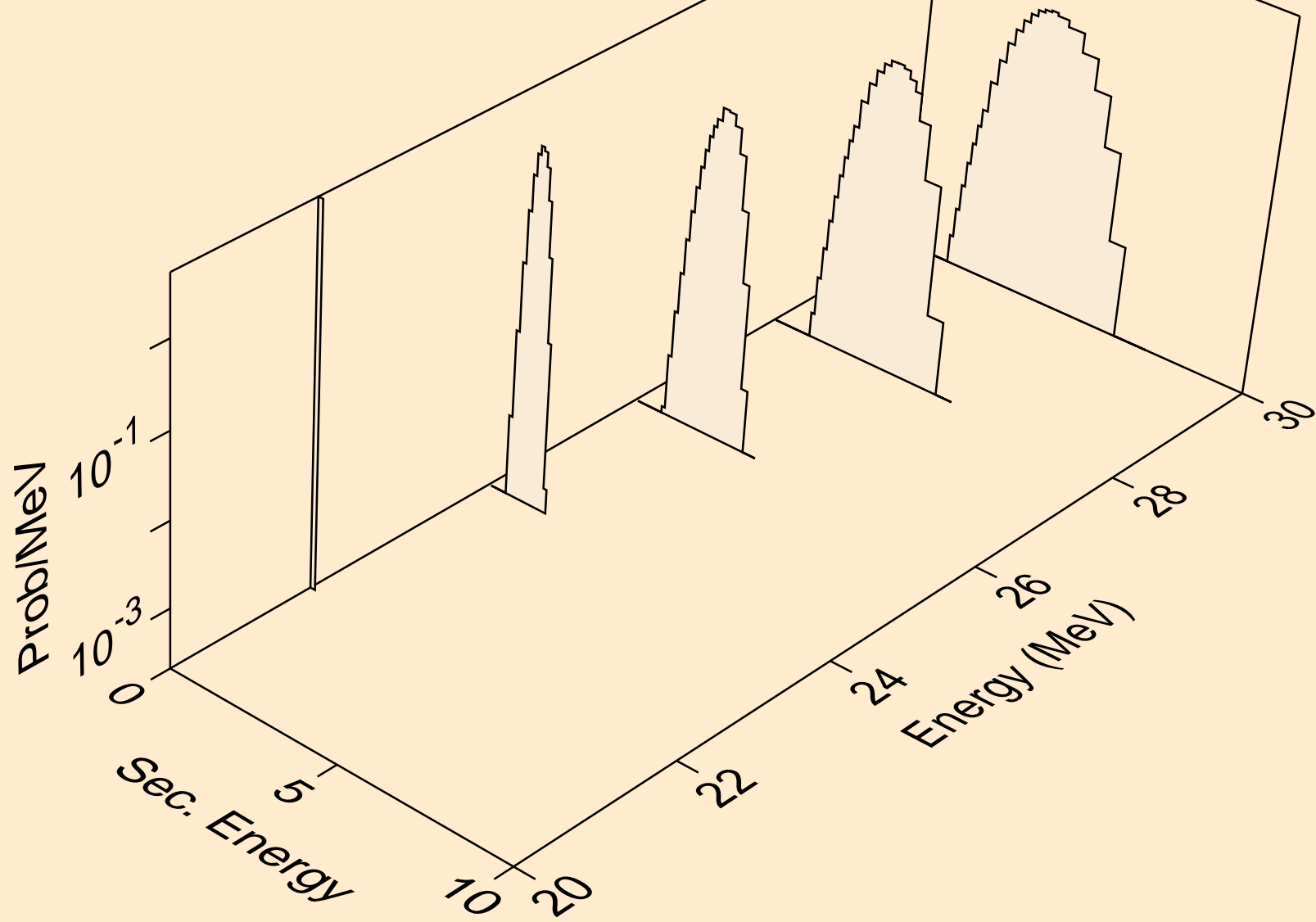

K042 ALPHA ACER TENDL-2024 LIBRARY; T=0.K  
he3s from (a,x)

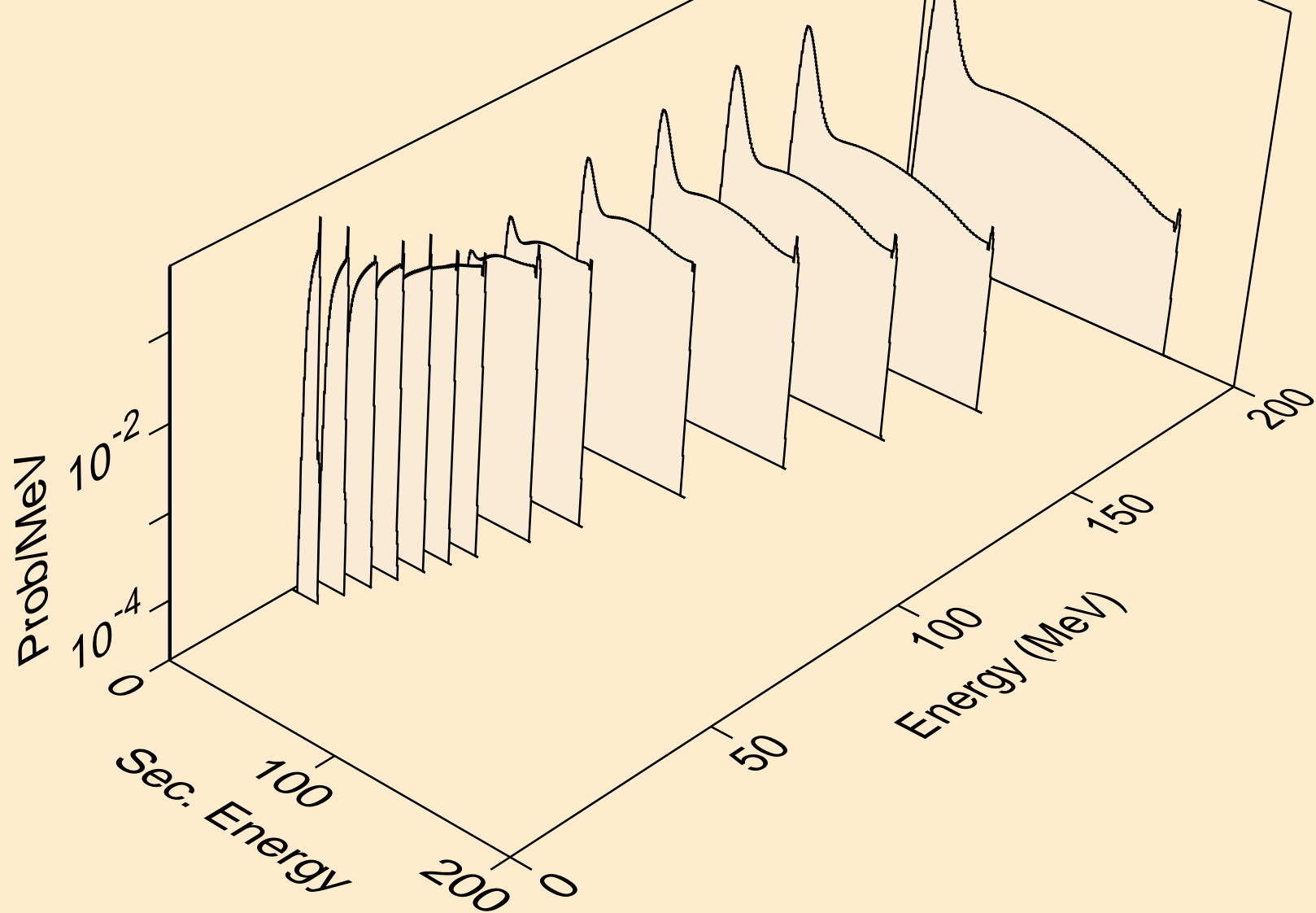

K042 ALPHA ACER TENDL-2024 LIBRARY; T=0.K  
he3s from (a,n\*)he3

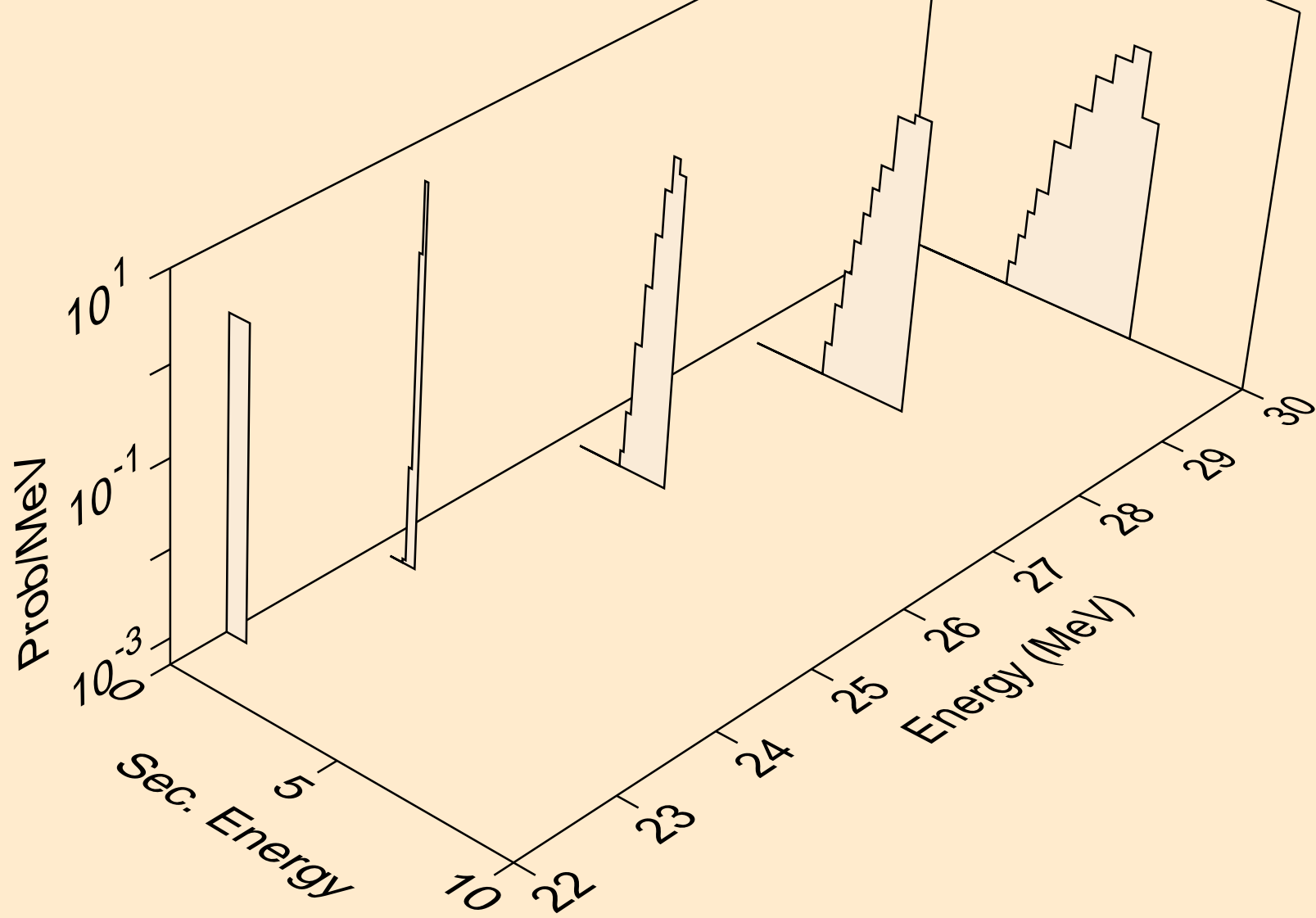

K042 ALPHA ACER TENDL-2024 LIBRARY; T=0.K  
he3s from (a,he3)

