

LU166N ALPHA ACER TENDL-2024 LIBRARY; T=0.K  
Principal cross sections

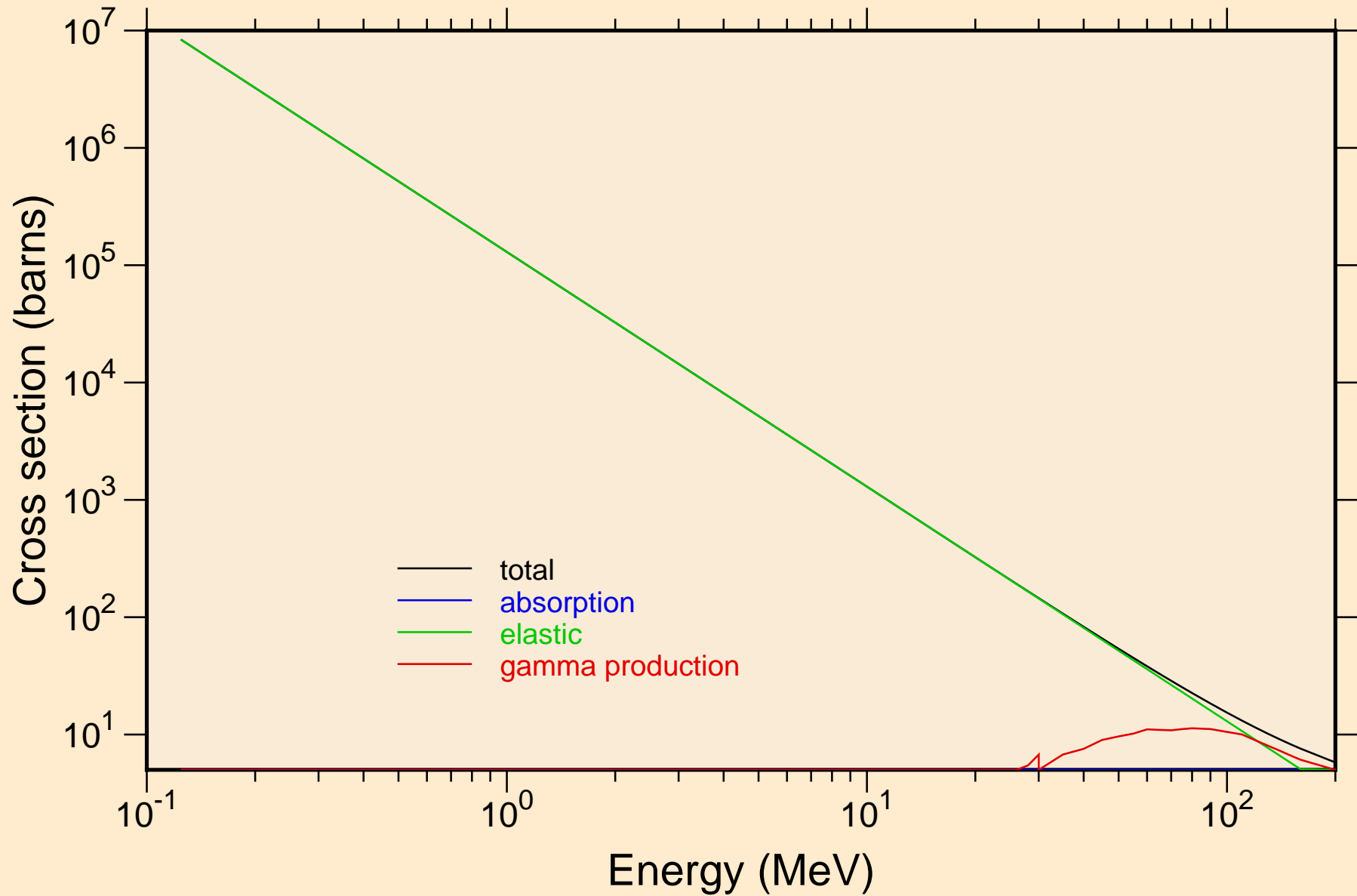

LU166N ALPHA ACER TENDL-2024 LIBRARY; T=0.K

Heating

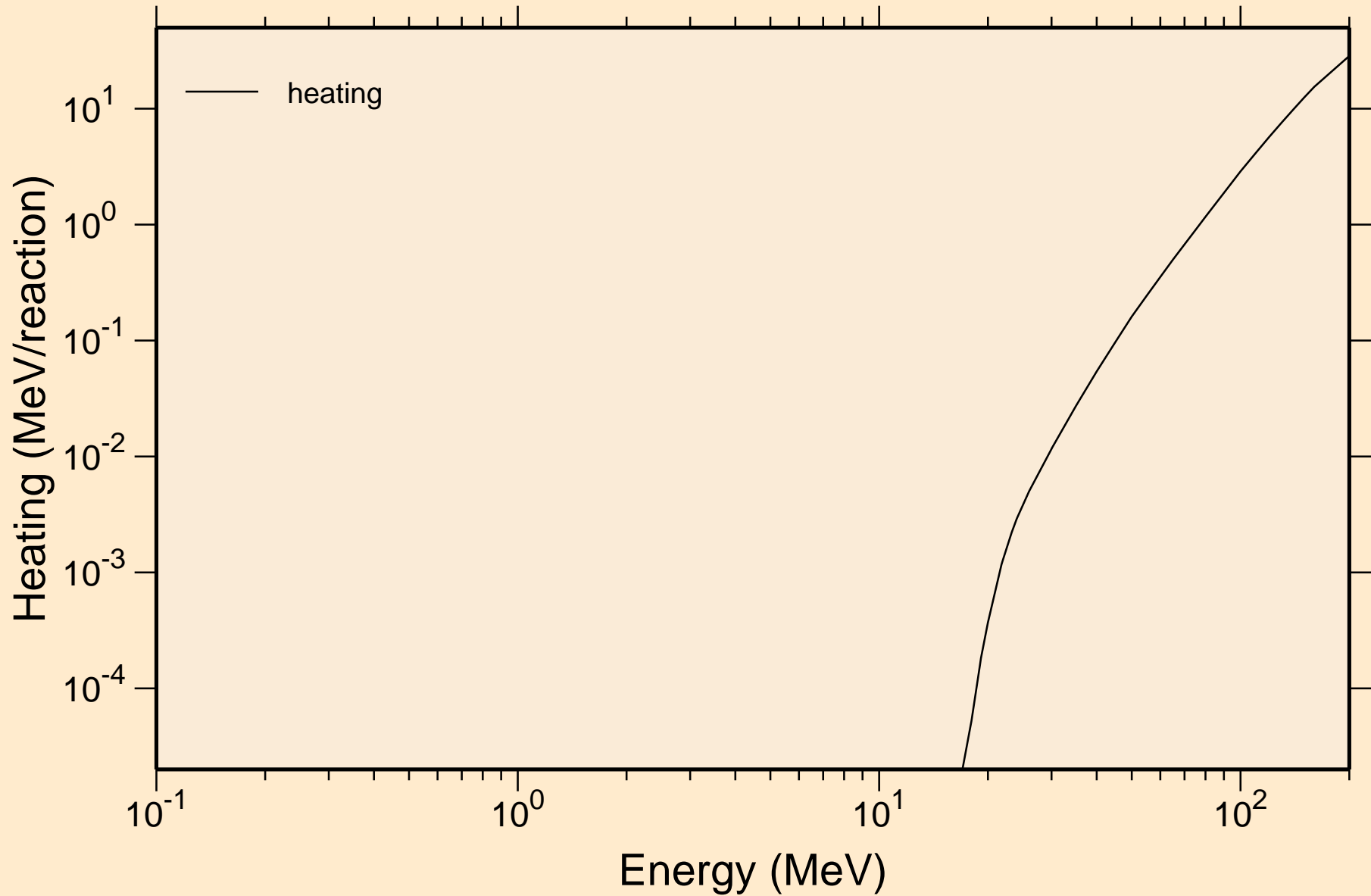

# LU166N ALPHA ACER TENDL-2024 LIBRARY; T=0.K

## Principal cross sections

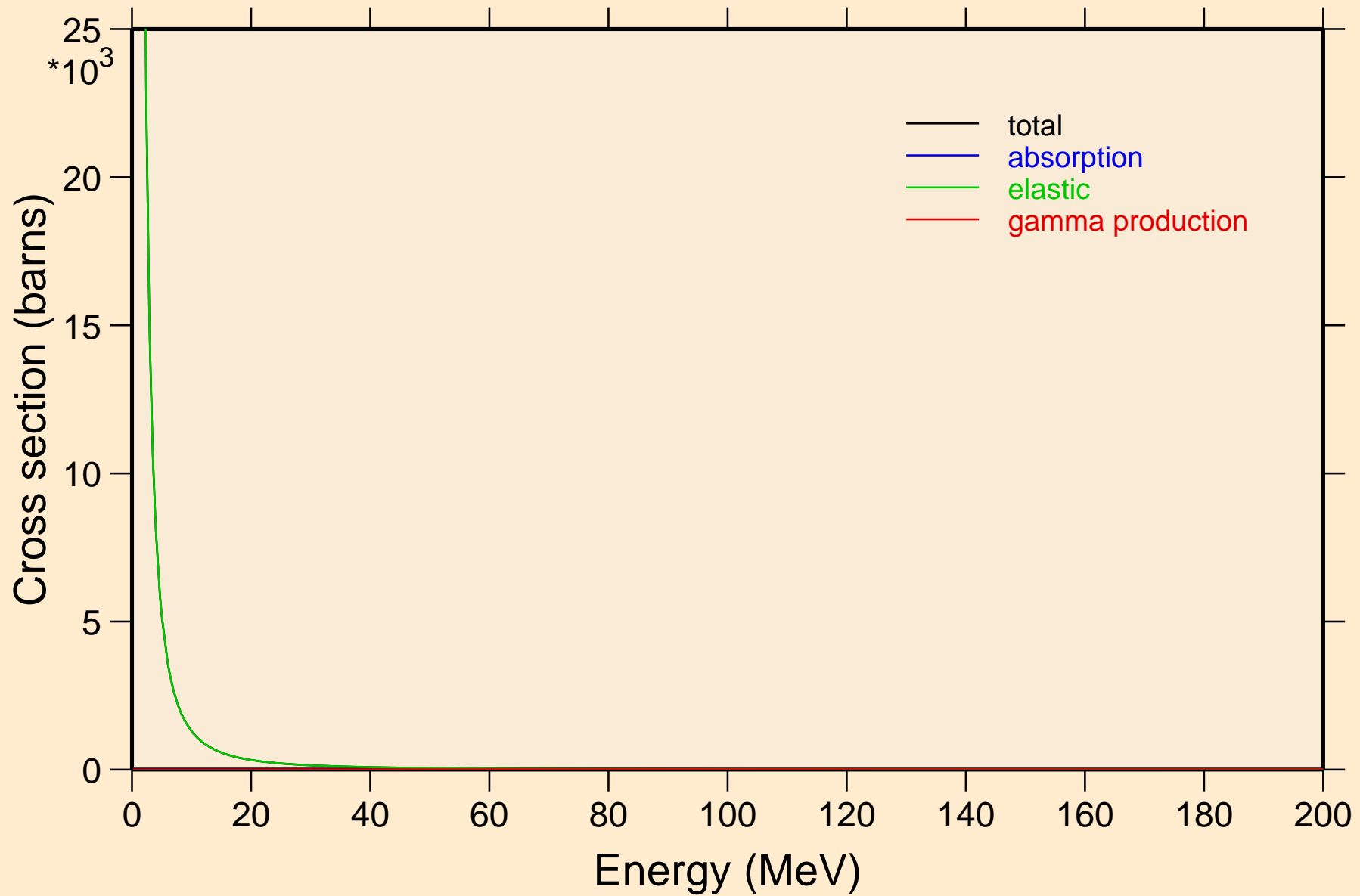

LU166N ALPHA ACER TENDL-2024 LIBRARY; T=0.K

Heating

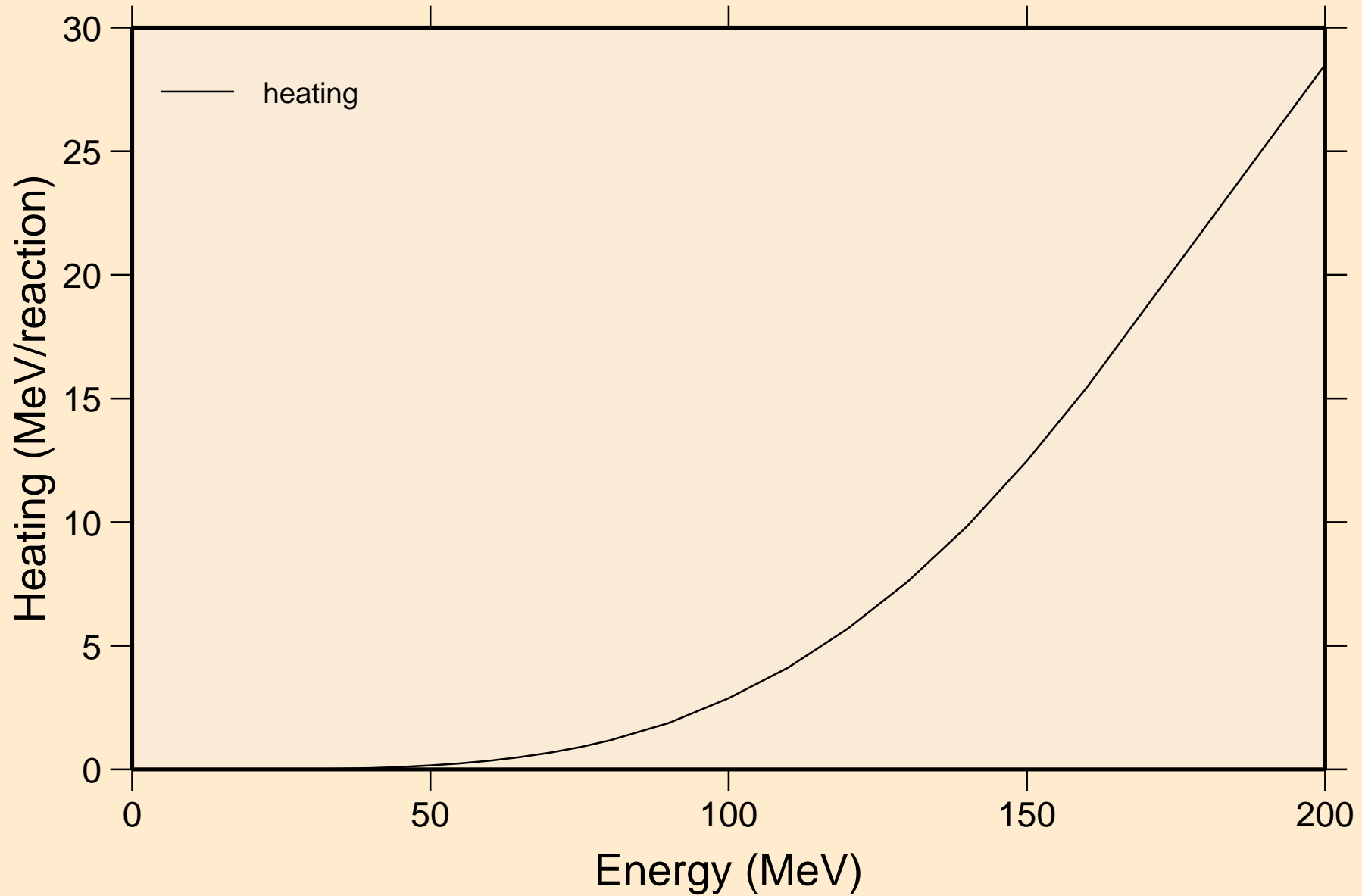

LU166N ALPHA ACER TENDL-2024 LIBRARY; T=0.K  
Threshold reactions

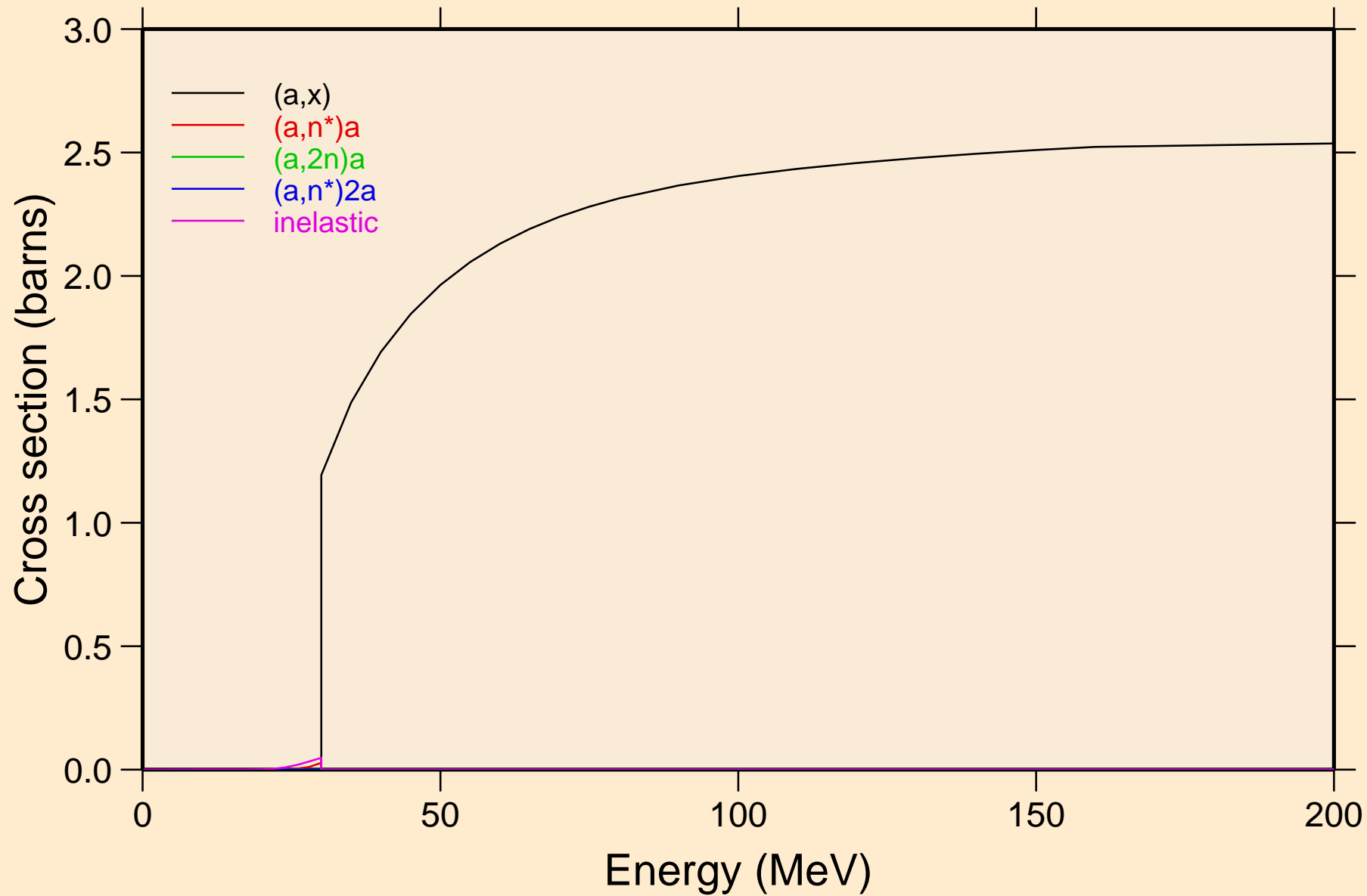

LU166N ALPHA ACER TENDL-2024 LIBRARY; T=0.K  
Threshold reactions

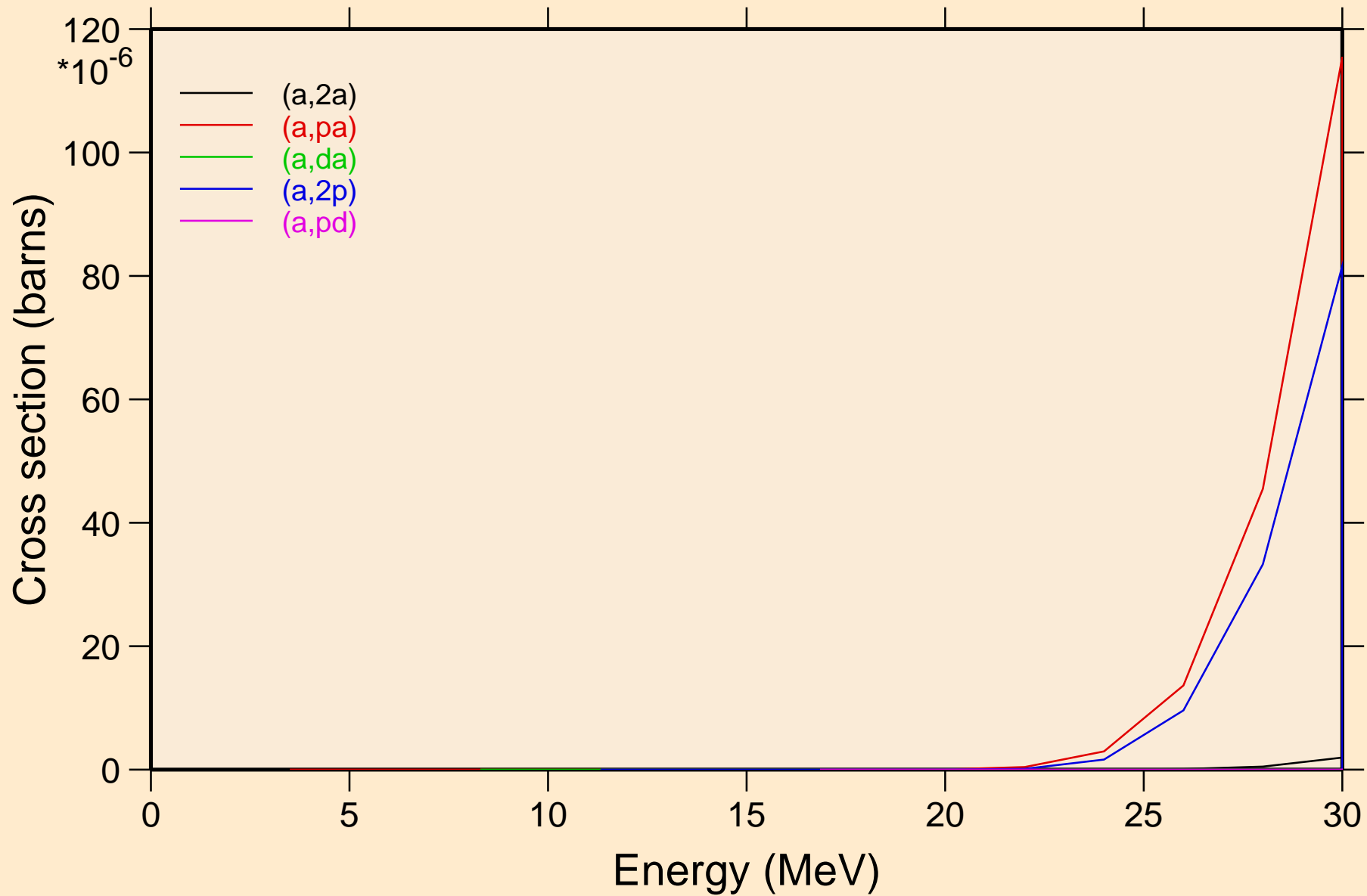

LU166N ALPHA ACER TENDL-2024 LIBRARY; T=0.K  
Threshold reactions

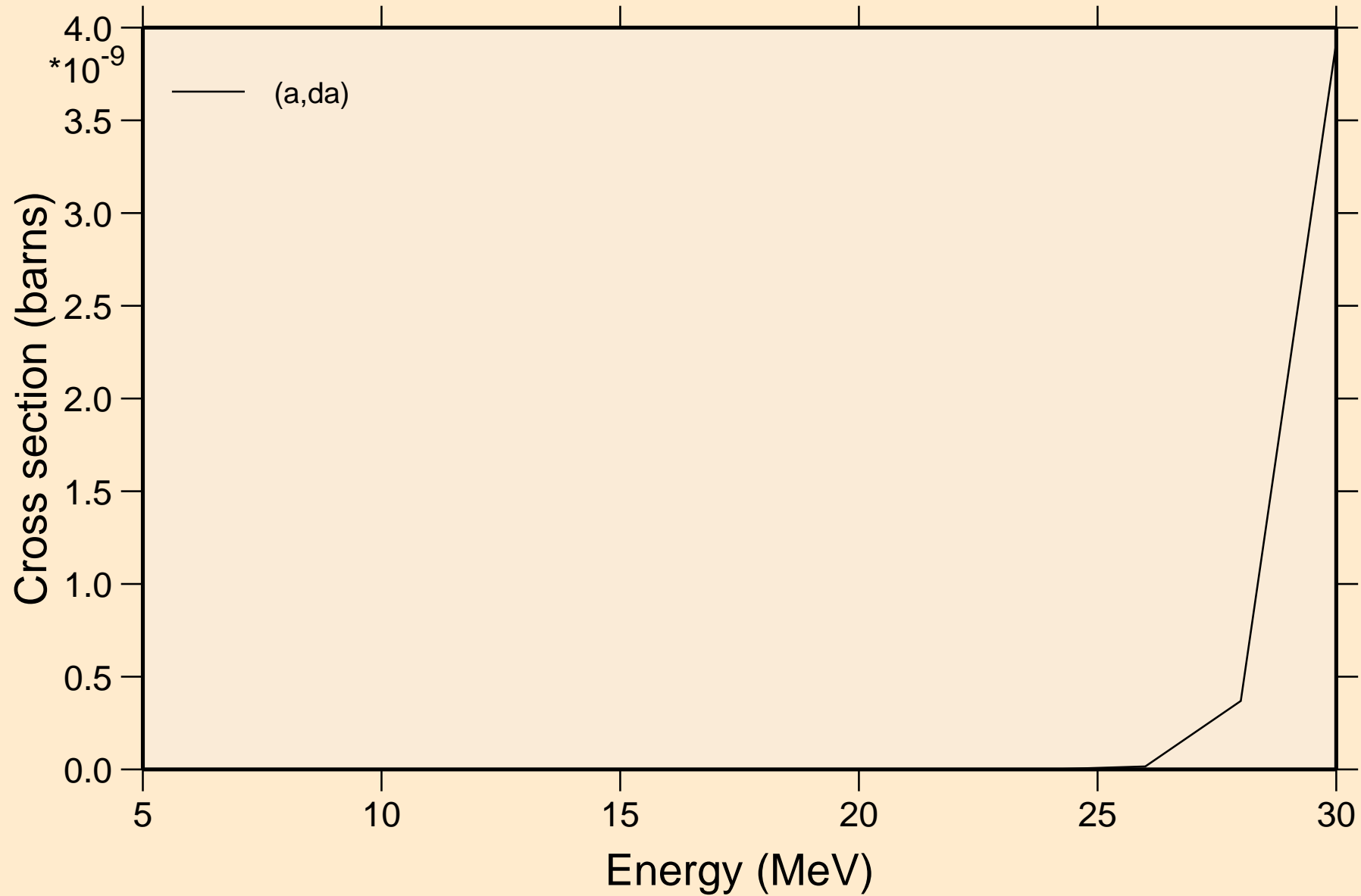

LU166N ALPHA ACER TENDL-2024 LIBRARY; T=0.K  
angular distribution for elastic

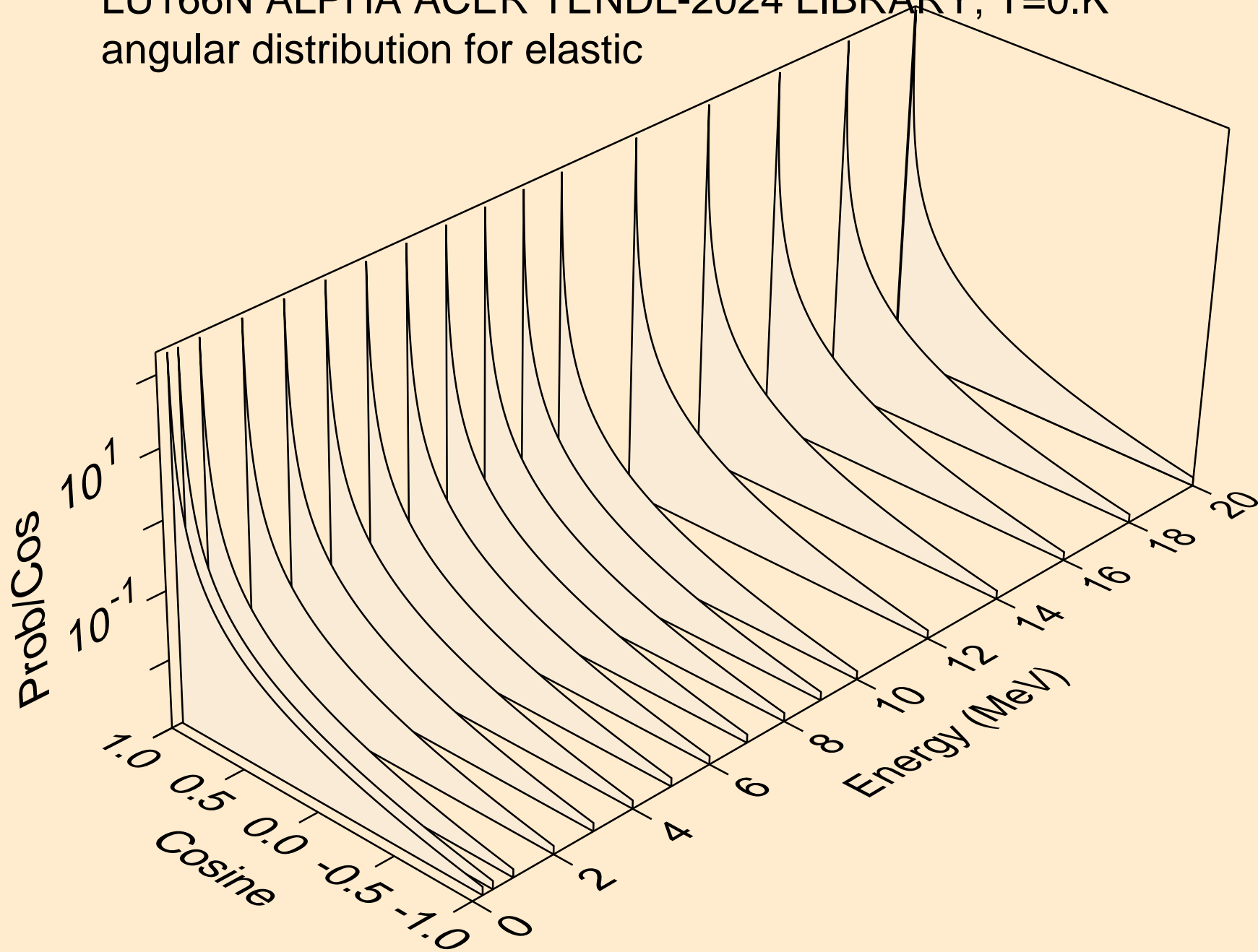

LU166N ALPHA ACER TENDL-2024 LIBRARY; T=0.K  
angular distribution for elastic

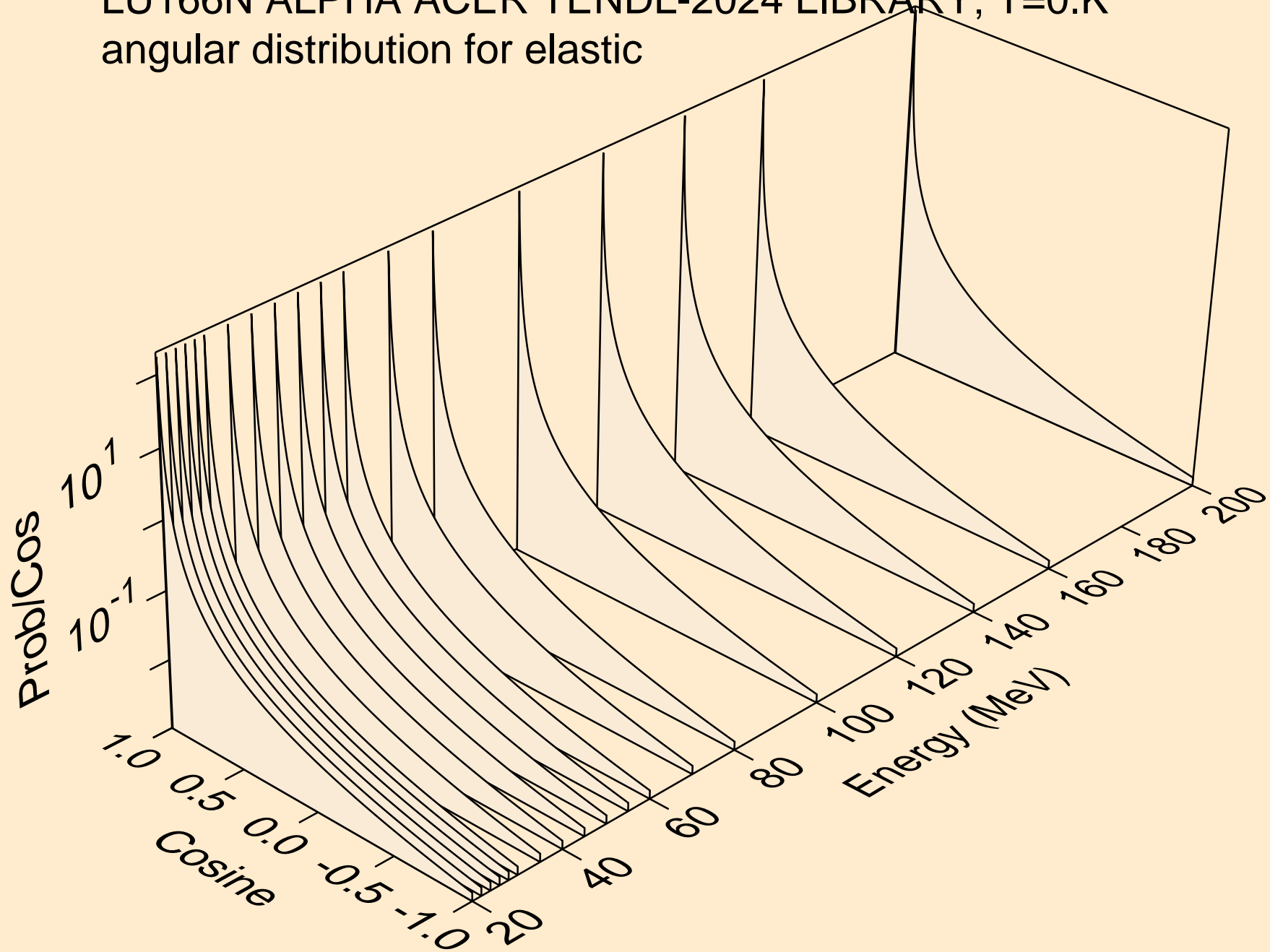

LU166N ALPHA ACER TENDL-2024 LIBRARY; T=0.K  
Alpha emission for (a,x)

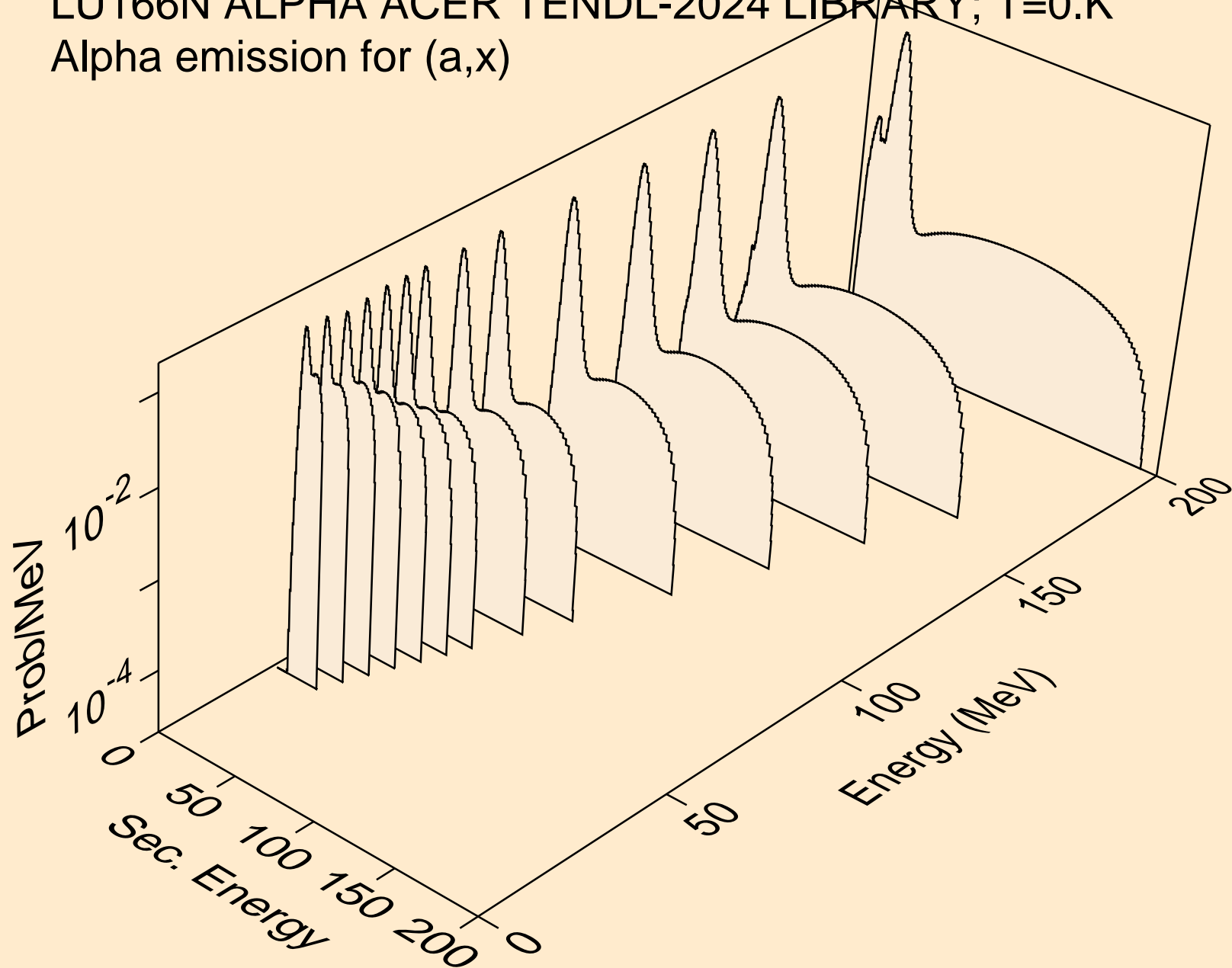

LU166N ALPHA ACER TENDL-2024 LIBRARY; T=0.K  
Alpha emission for (a,n\*)a

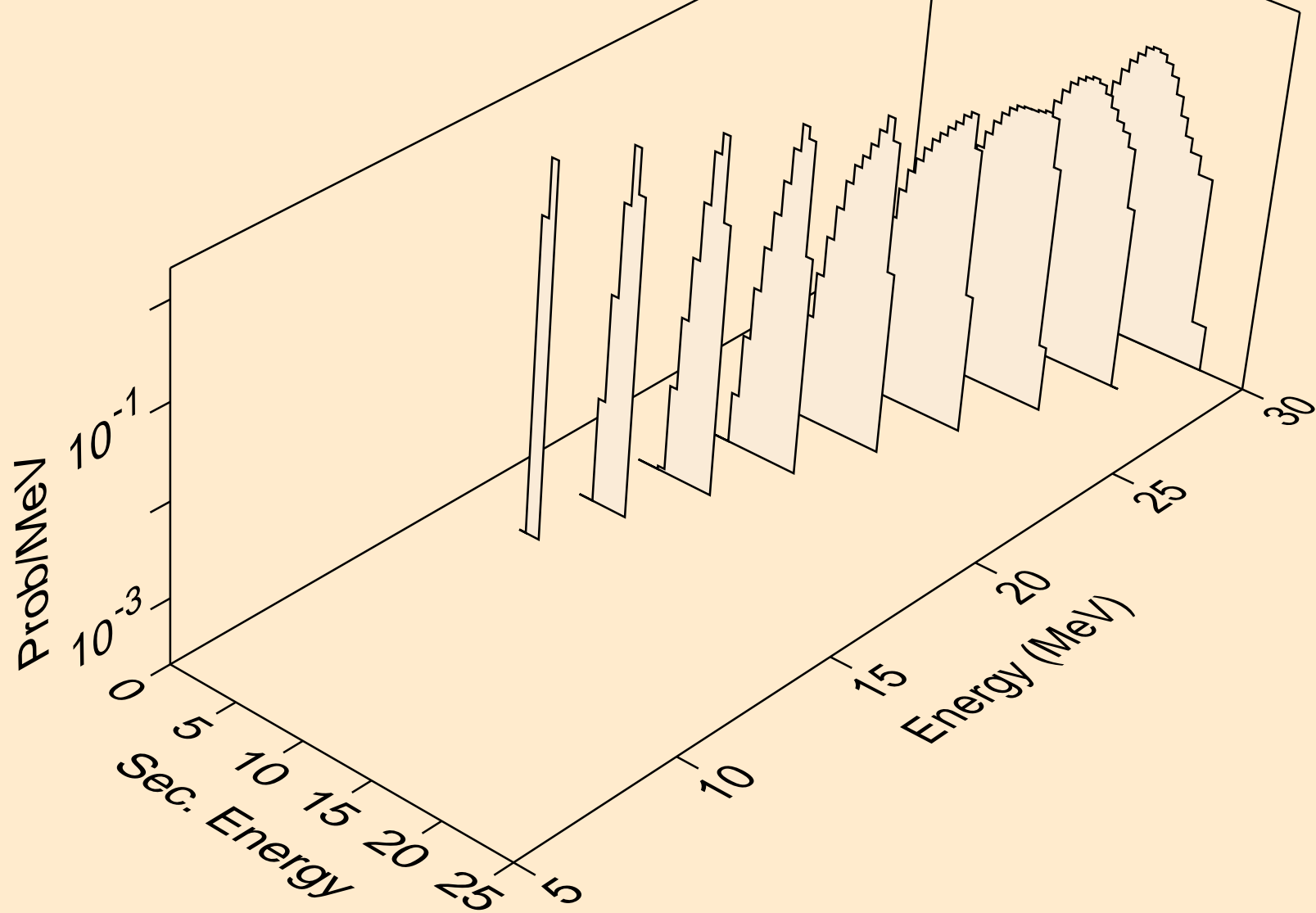

LU166N ALPHA ACER TENDL-2024 LIBRARY; T=0.K  
Alpha emission for (a,2n)a

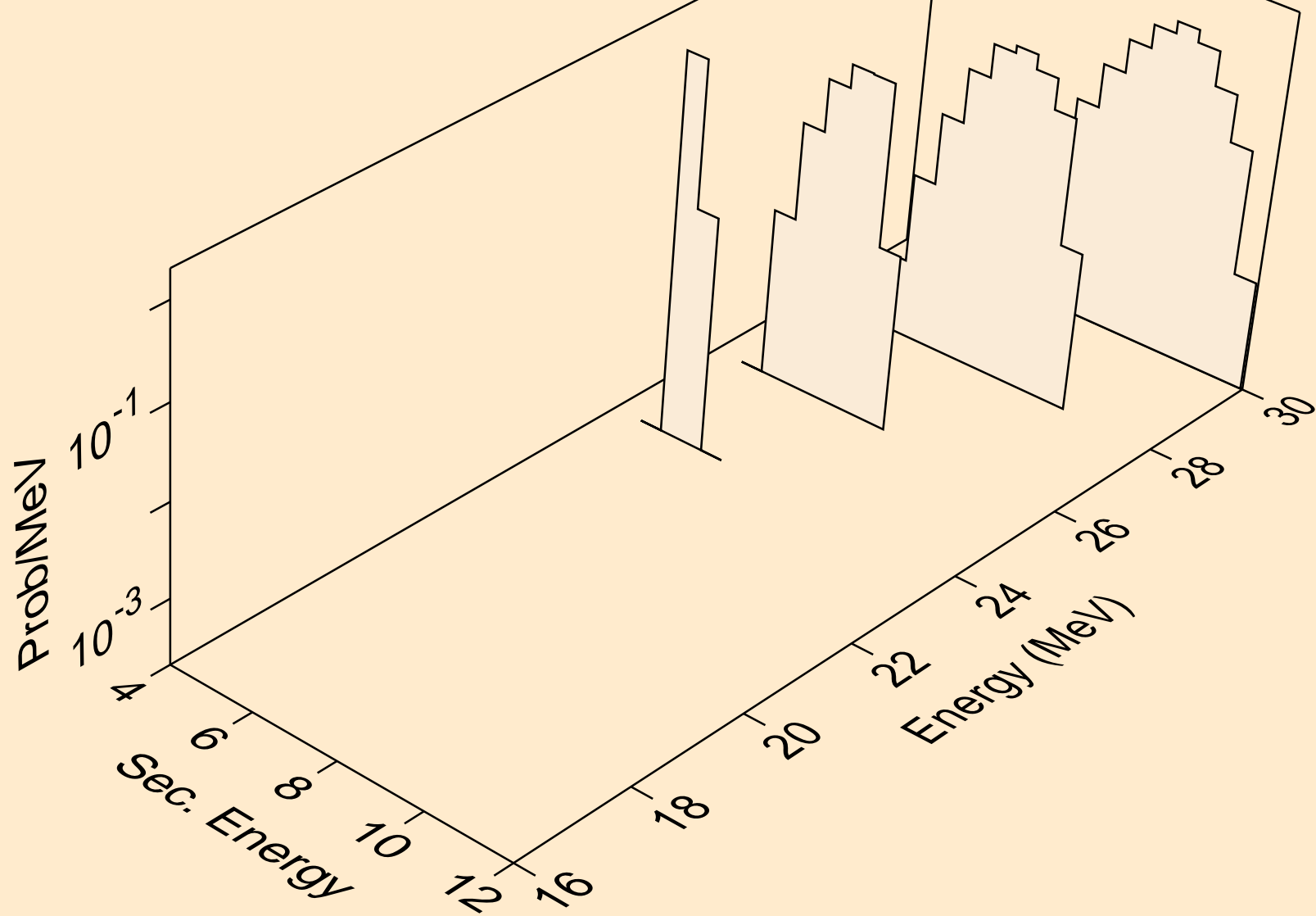

LU166N ALPHA ACER TENDL-2024 LIBRARY; T=0.K  
Alpha emission for (a,n\*)2a

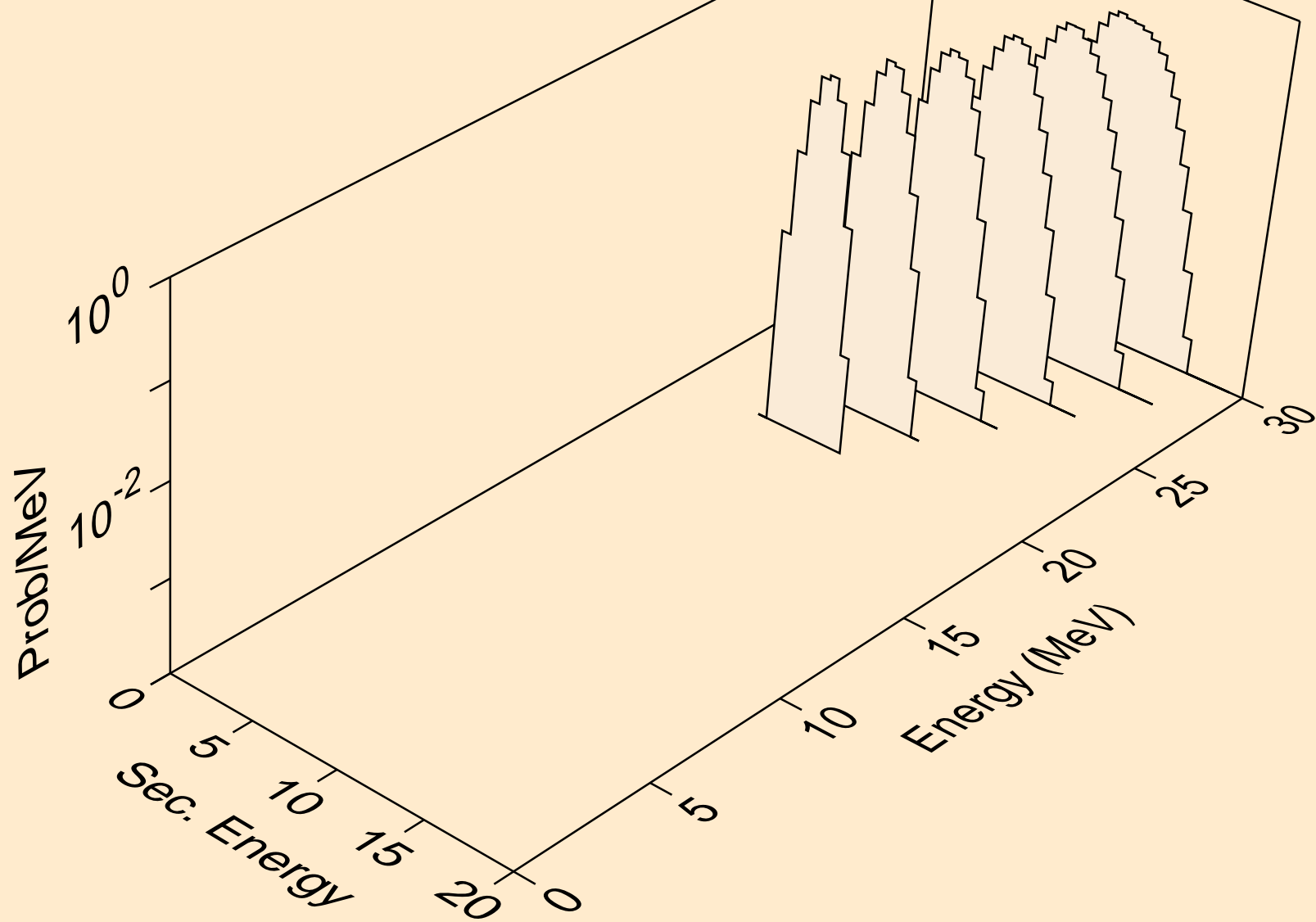

LU166N ALPHA ACER TENDL-2024 LIBRARY; T=0.K  
Alpha emission for inelastic

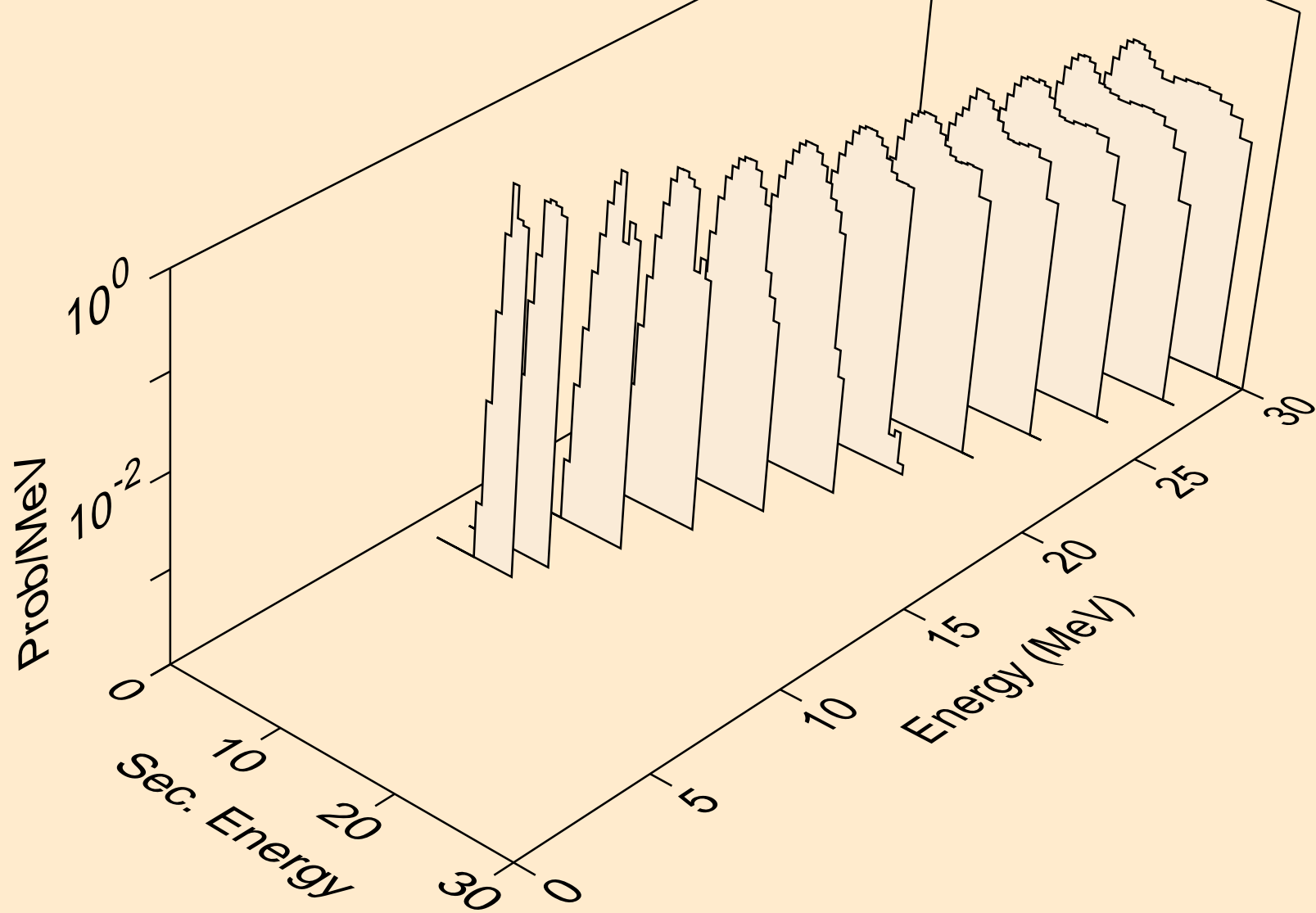

LU166N ALPHA ACER TENDL-2024 LIBRARY; T=0.K  
Alpha emission for (a,2a)

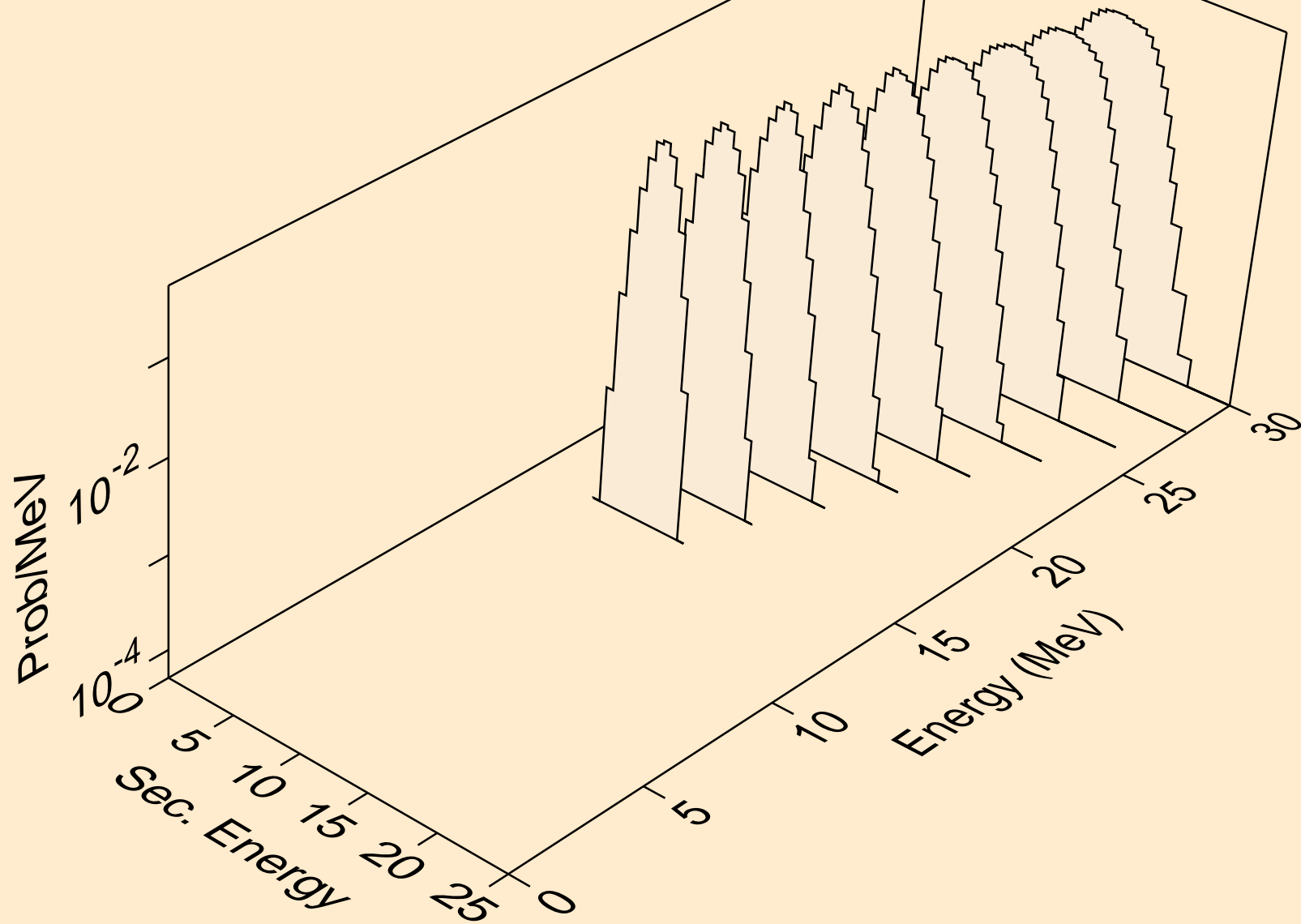

LU166N ALPHA ACER TENDL-2024 LIBRARY; T=0.K  
Alpha emission for (a,pa)

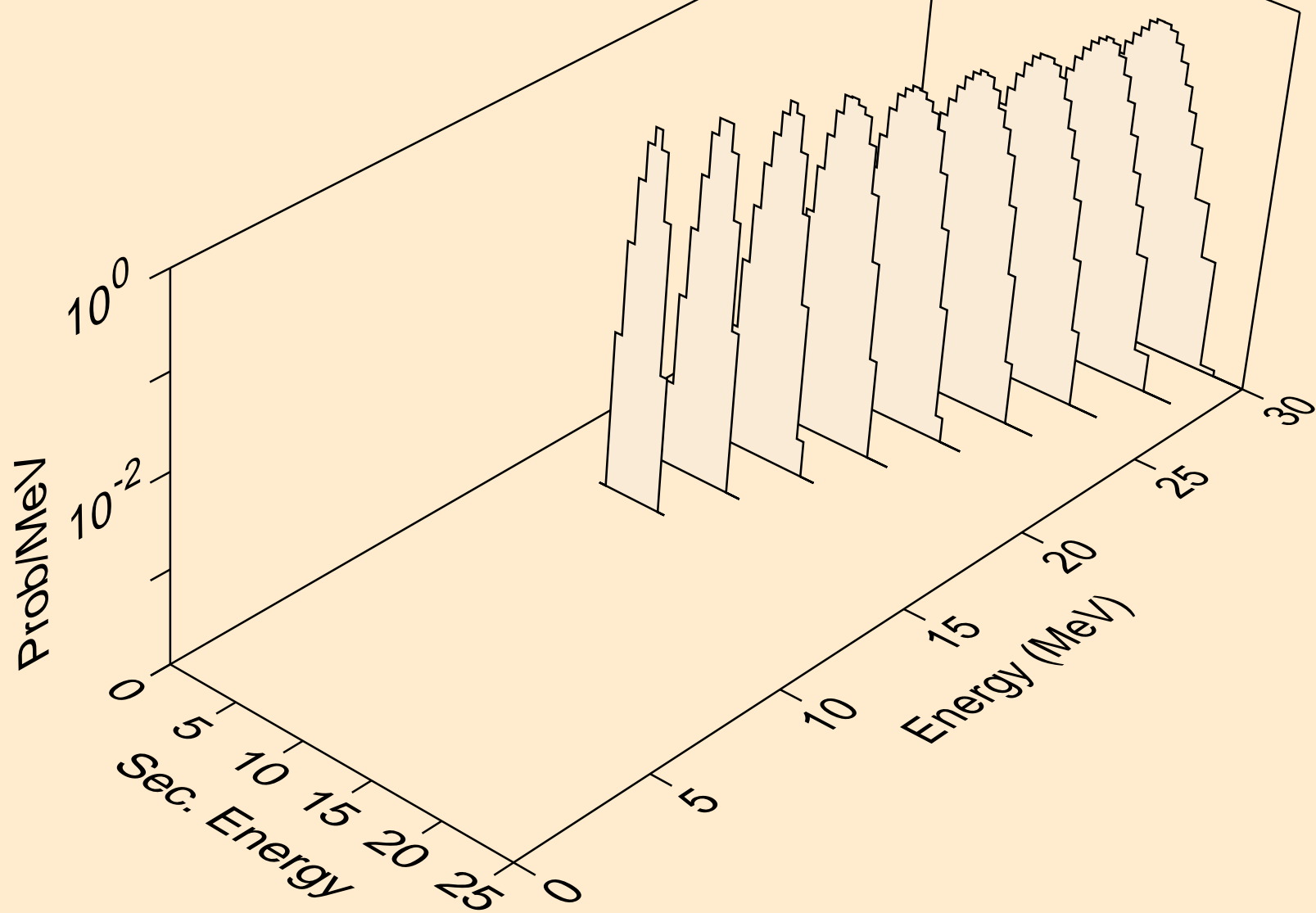

LU166N ALPHA ACER TENDL-2024 LIBRARY; T=0.K  
Alpha emission for (a,da)

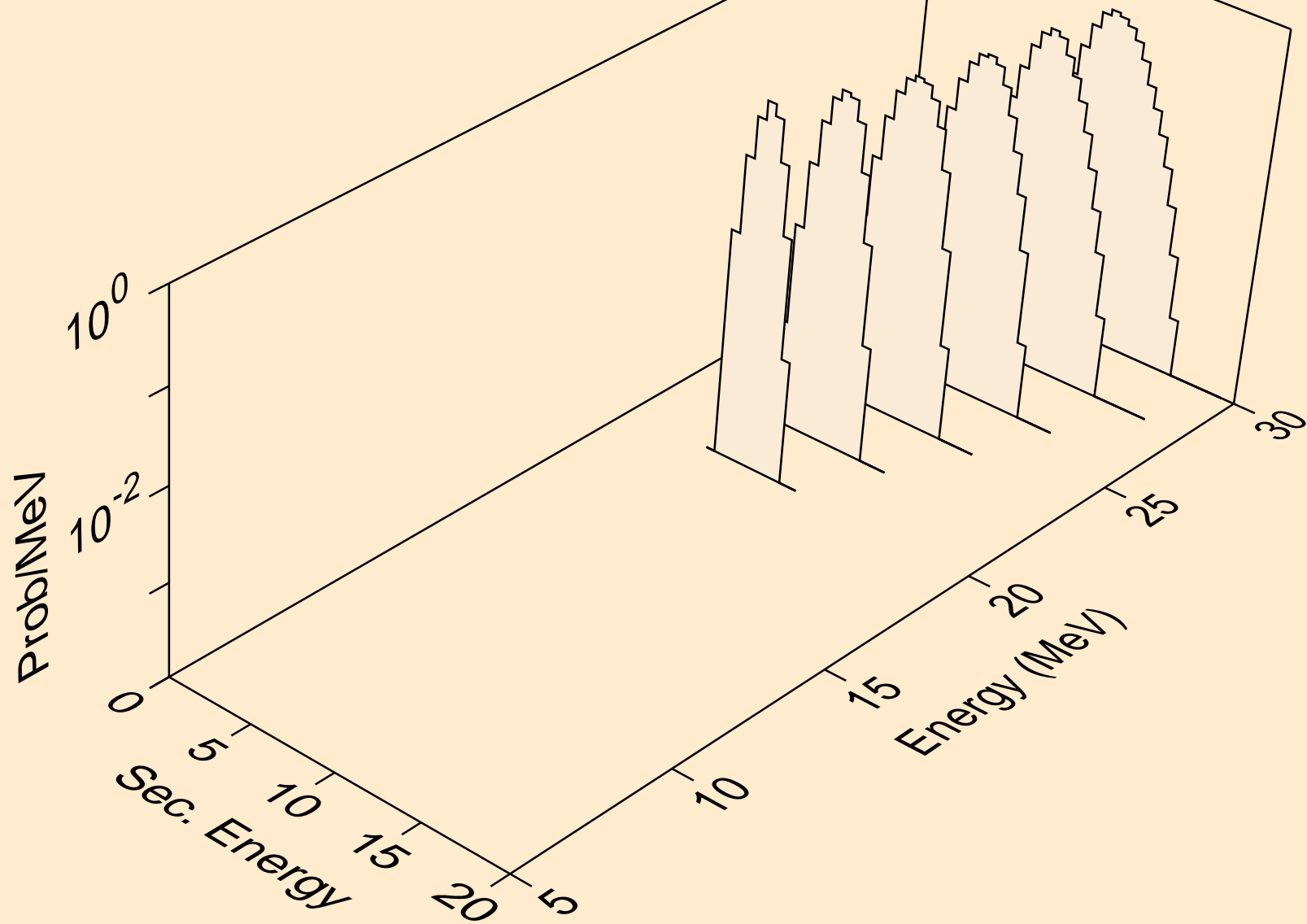

LU166N ALPHA ACER TENDL-2024 LIBRARY; T=0.K  
Photon emission for (z,n)

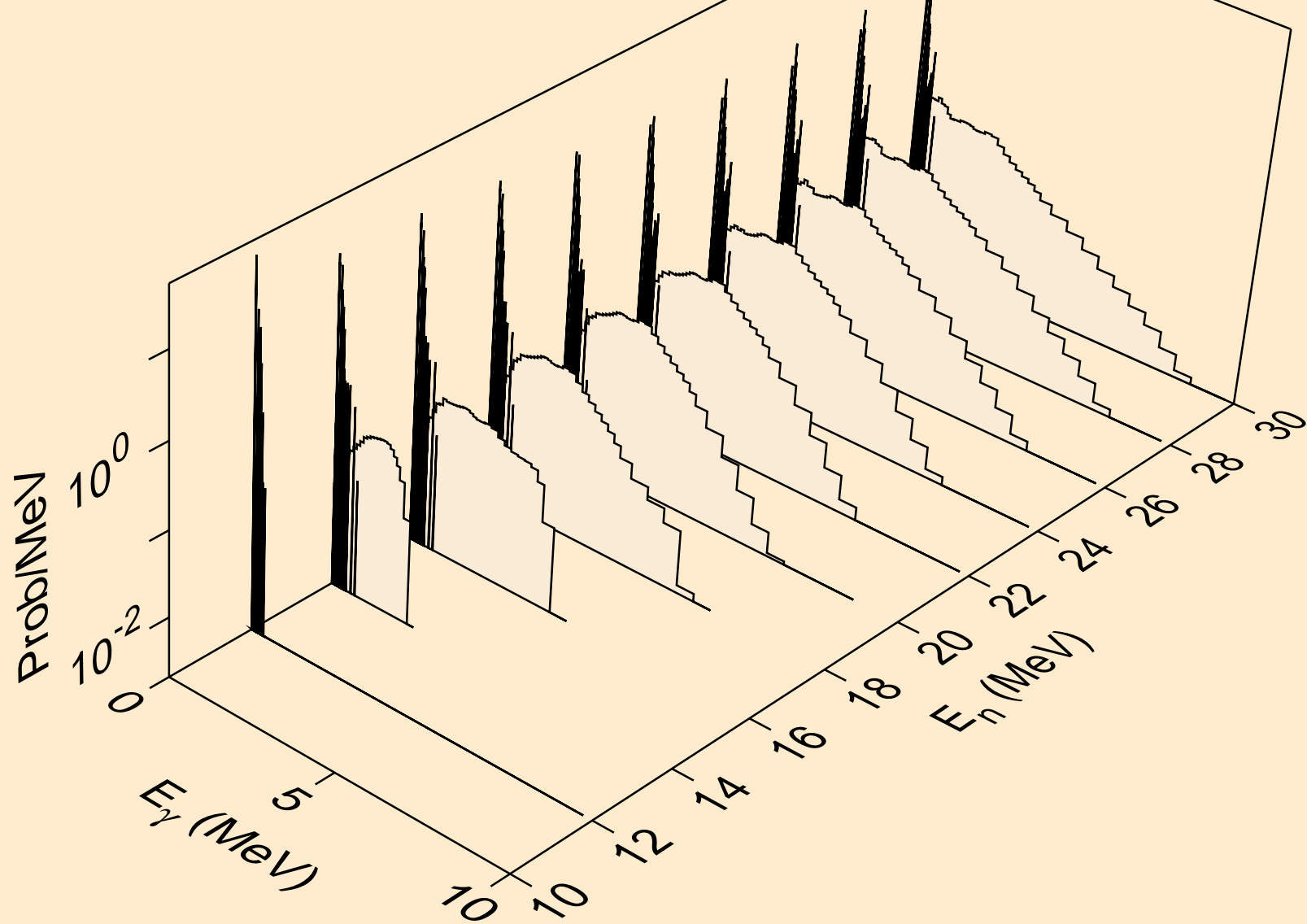

LU166N ALPHA ACER TENDL-2024 LIBRARY; T=0.K  
Photon emission for (z,x)

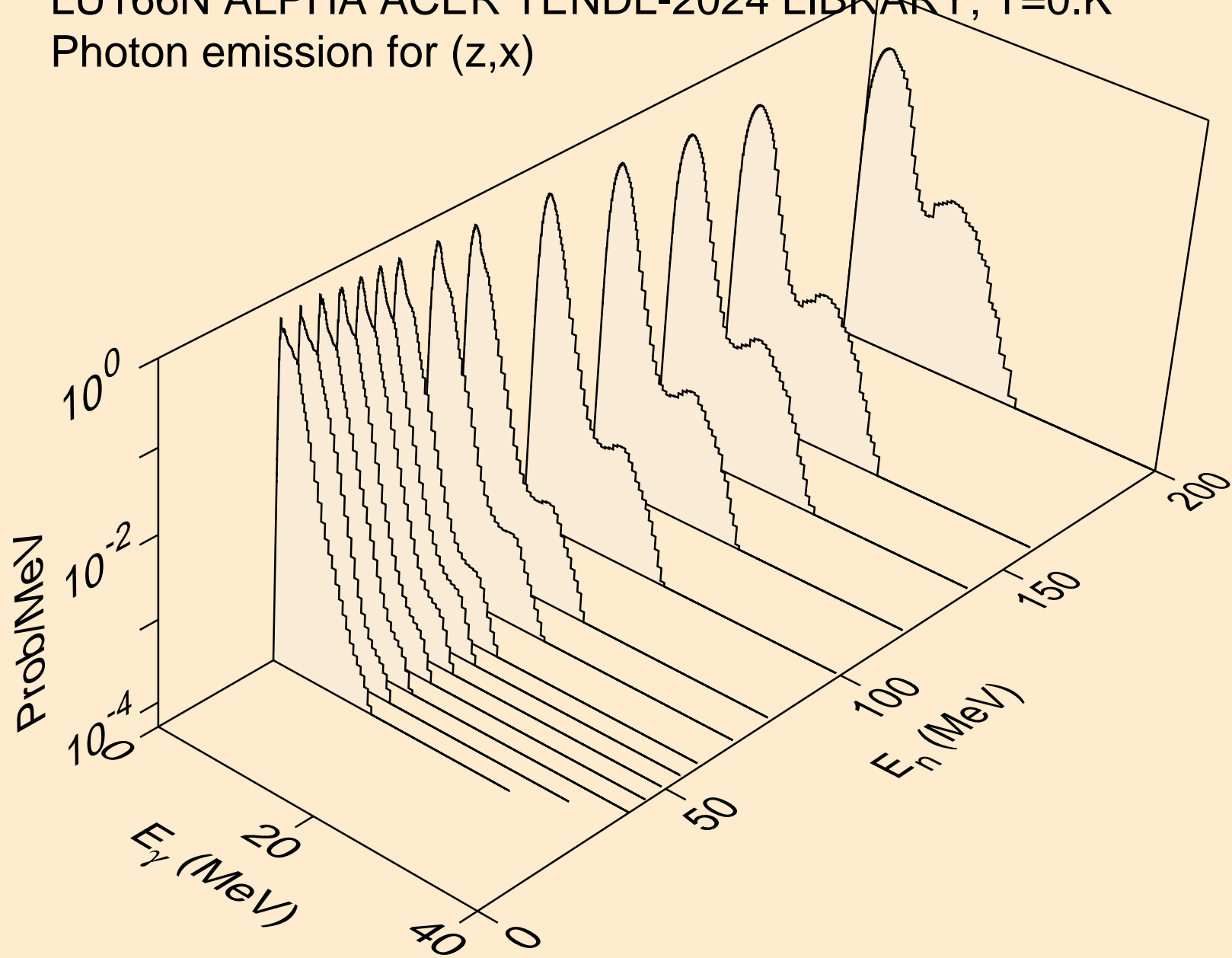

LU166N ALPHA ACER TENDL-2024 LIBRARY; T=0.K  
Photon emission for (n,2n)

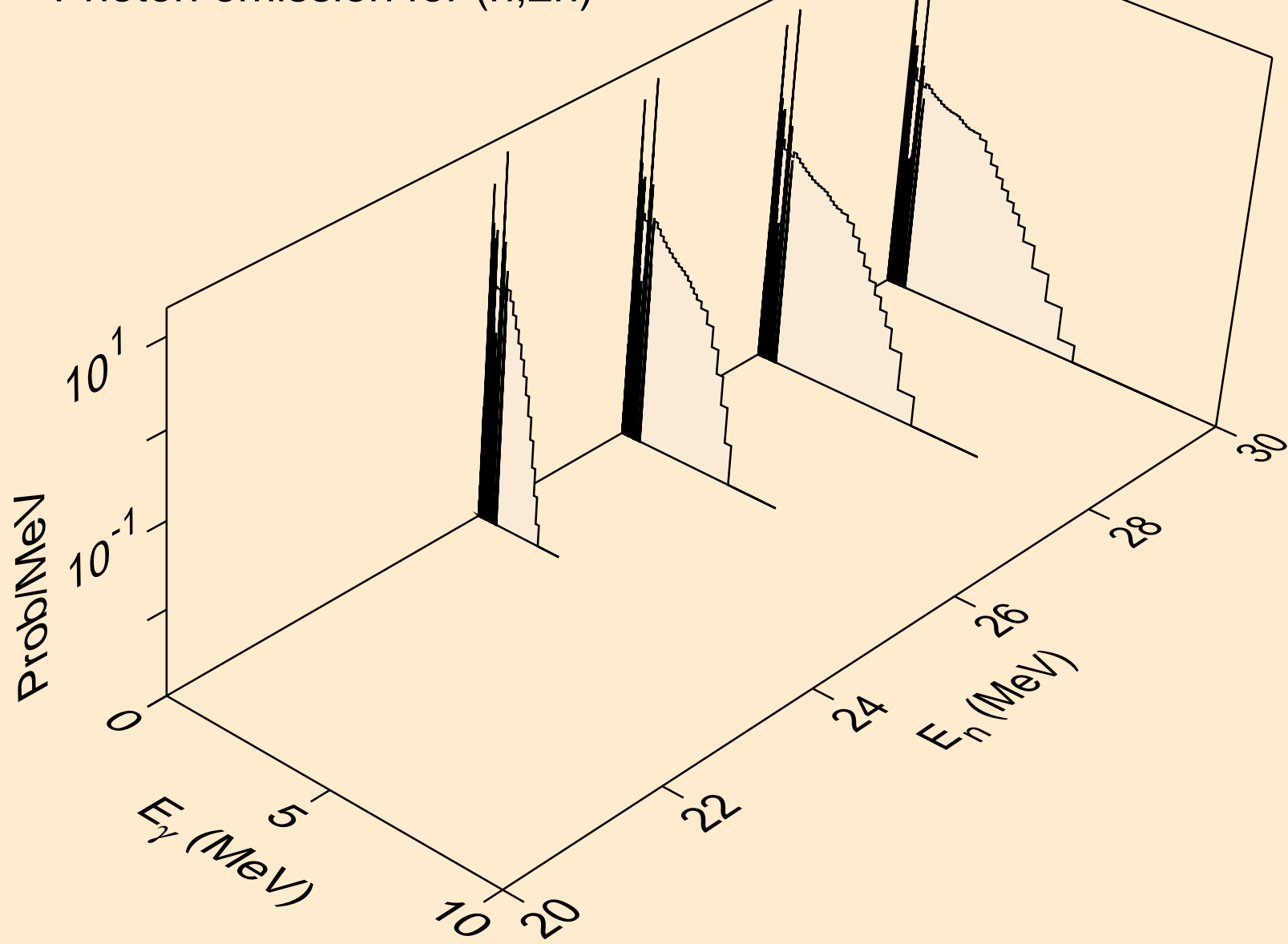

LU166N ALPHA ACER TENDL-2024 LIBRARY; T=0.K  
Photon emission for (n,n\*)a

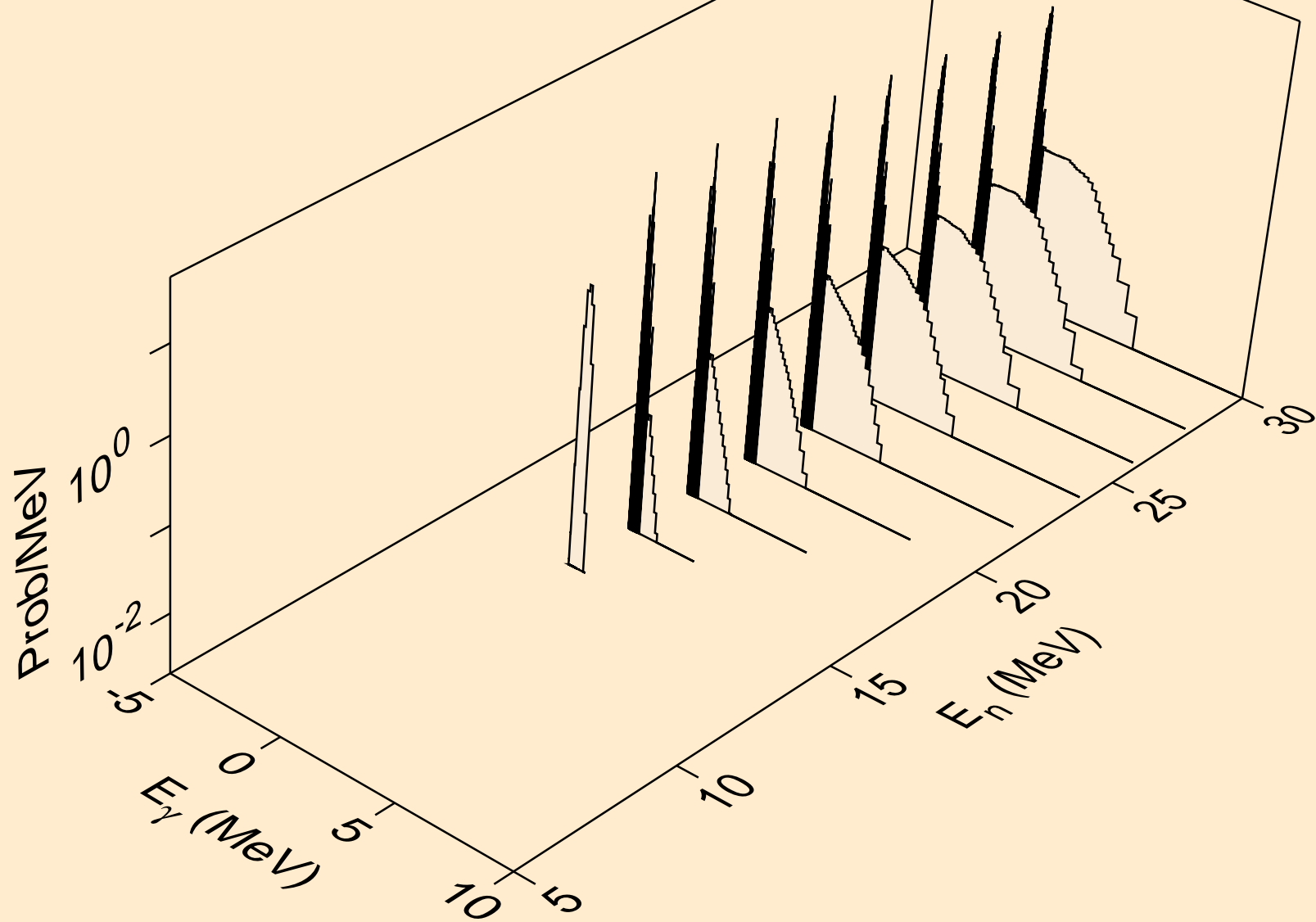

LU166N ALPHA ACER TENDL-2024 LIBRARY; T=0.K  
Photon emission for (n,2n)a

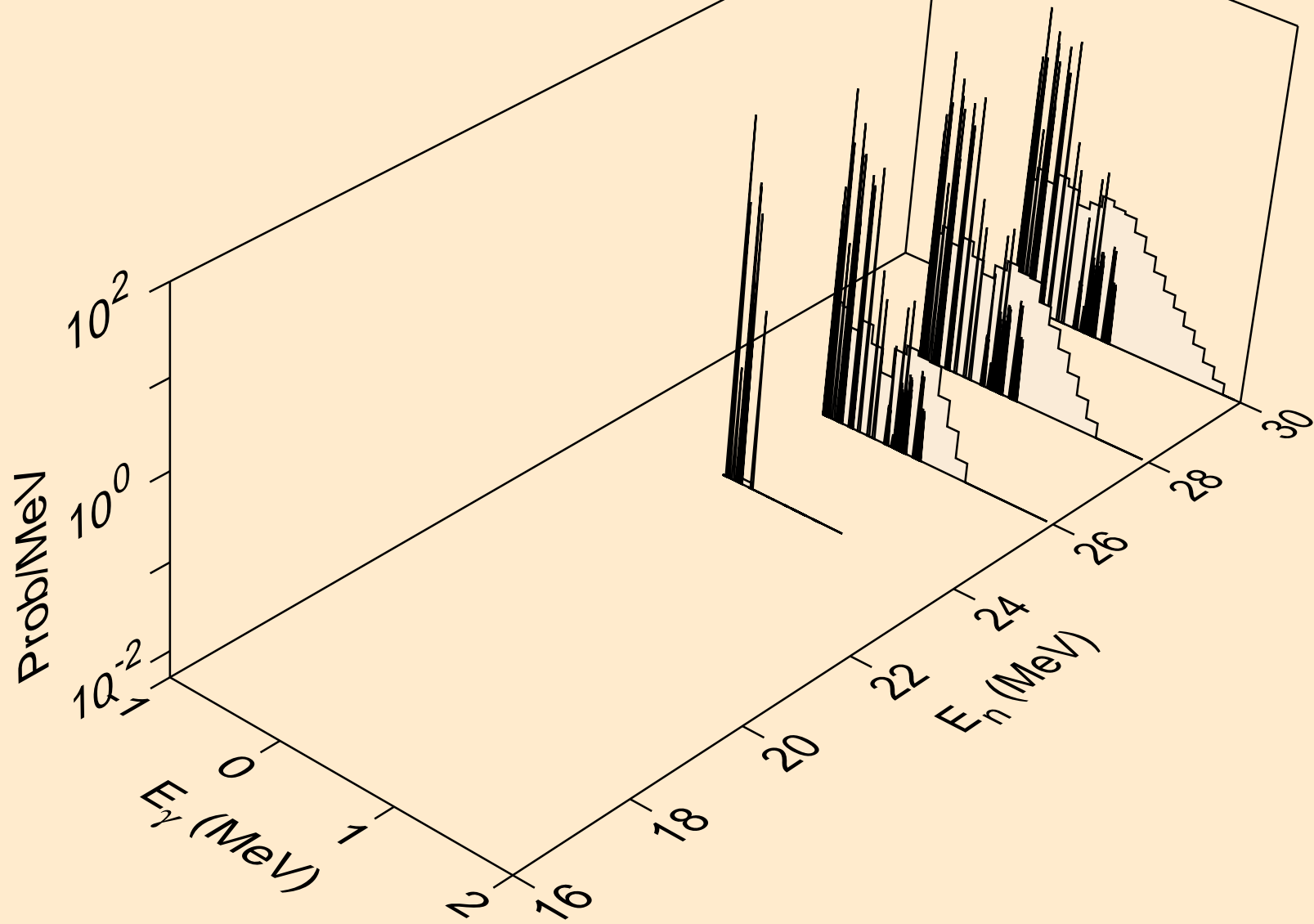

LU166N ALPHA ACER TENDL-2024 LIBRARY; T=0.K  
Photon emission for (n,n\*)p

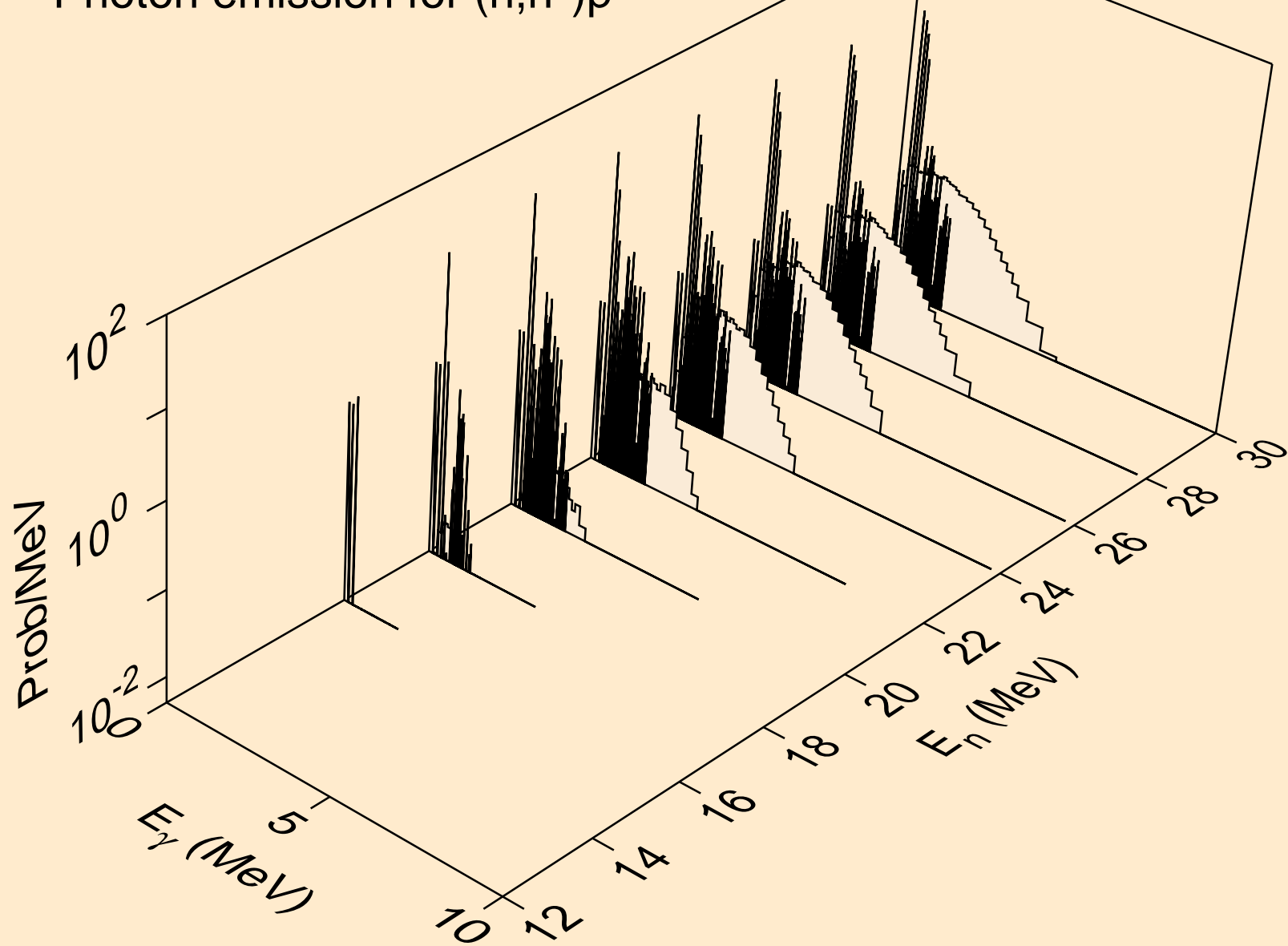

LU166N ALPHA ACER TENDL-2024 LIBRARY; T=0.K  
Photon emission for (n,n\*)2a

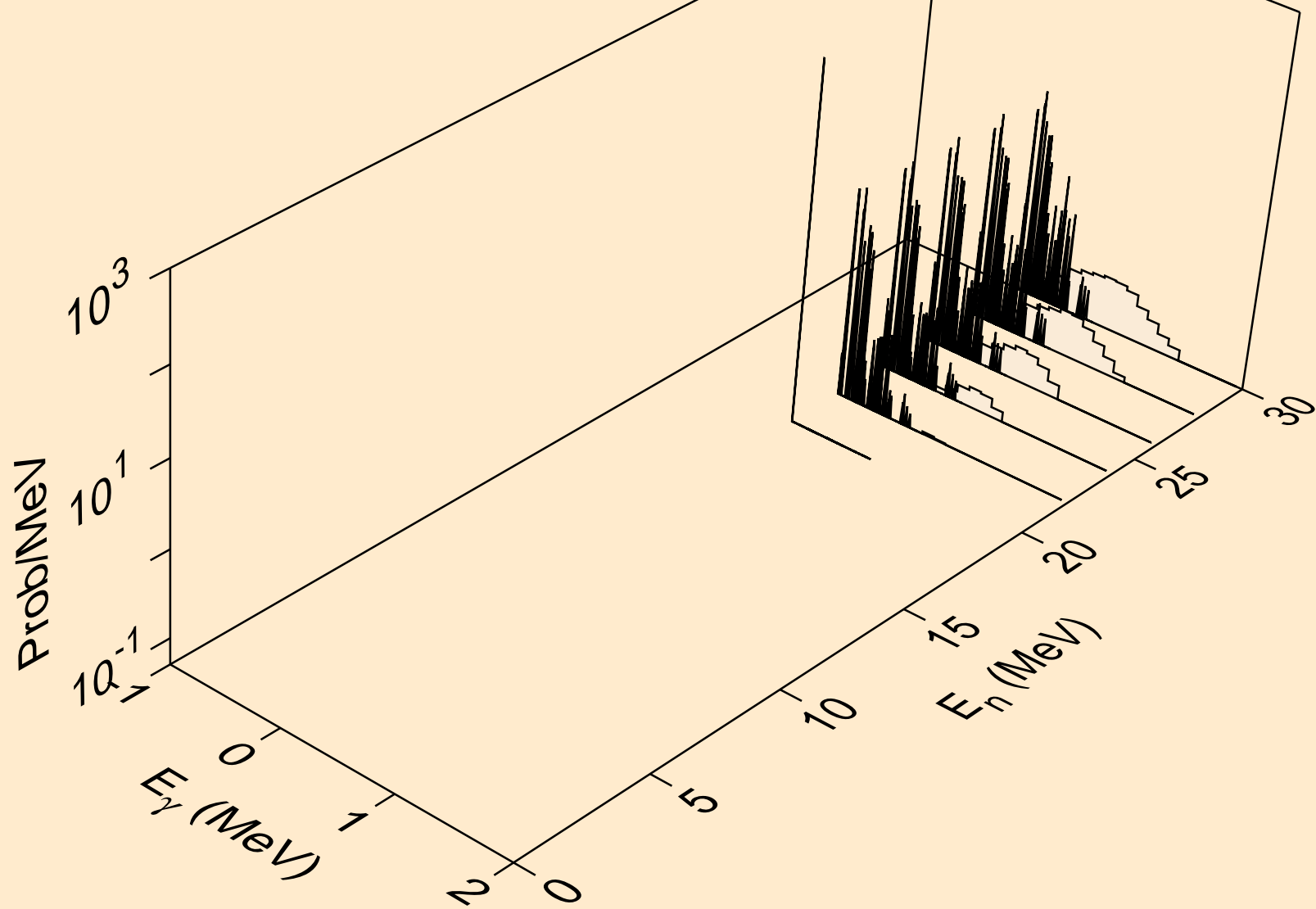

LU166N ALPHA ACER TENDL-2024 LIBRARY; T=0.K  
Photon emission for (n,n\*)d

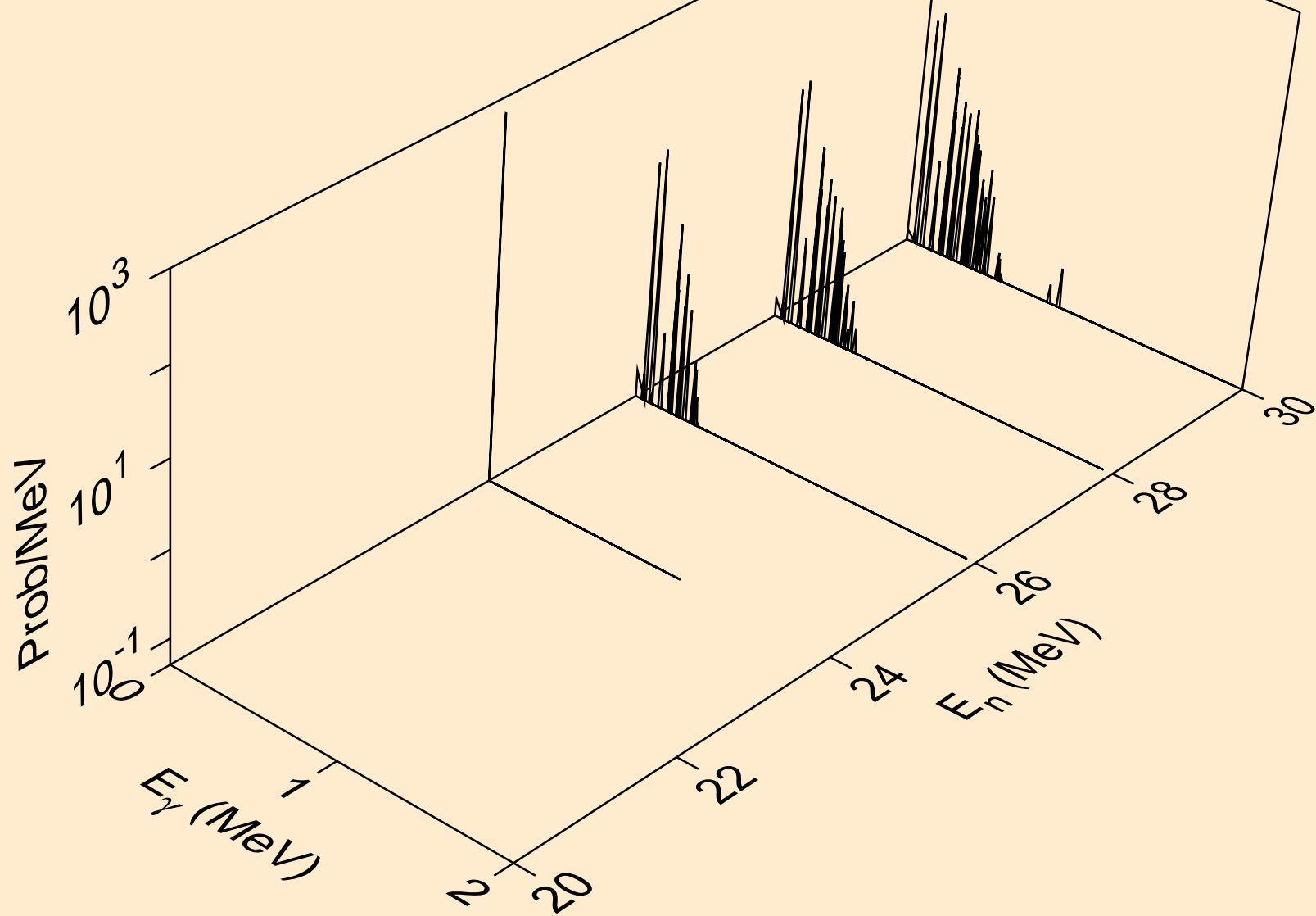

LU166N ALPHA ACER TENDL-2024 LIBRARY; T=0.K  
Photon emission for (n,n\*)t

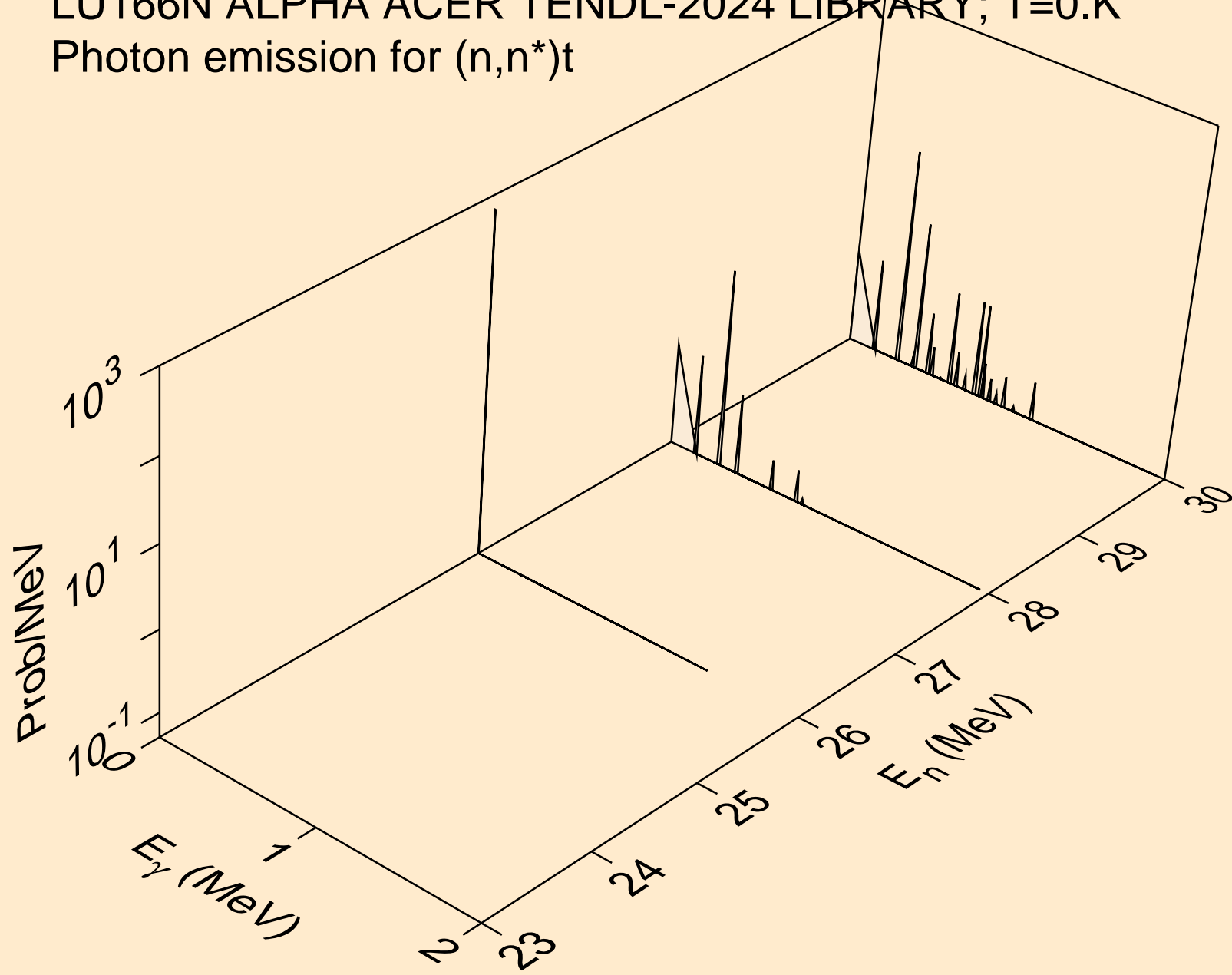

LU166N ALPHA ACER TENDL-2024 LIBRARY; T=0.K  
Photon emission for (n,2np)

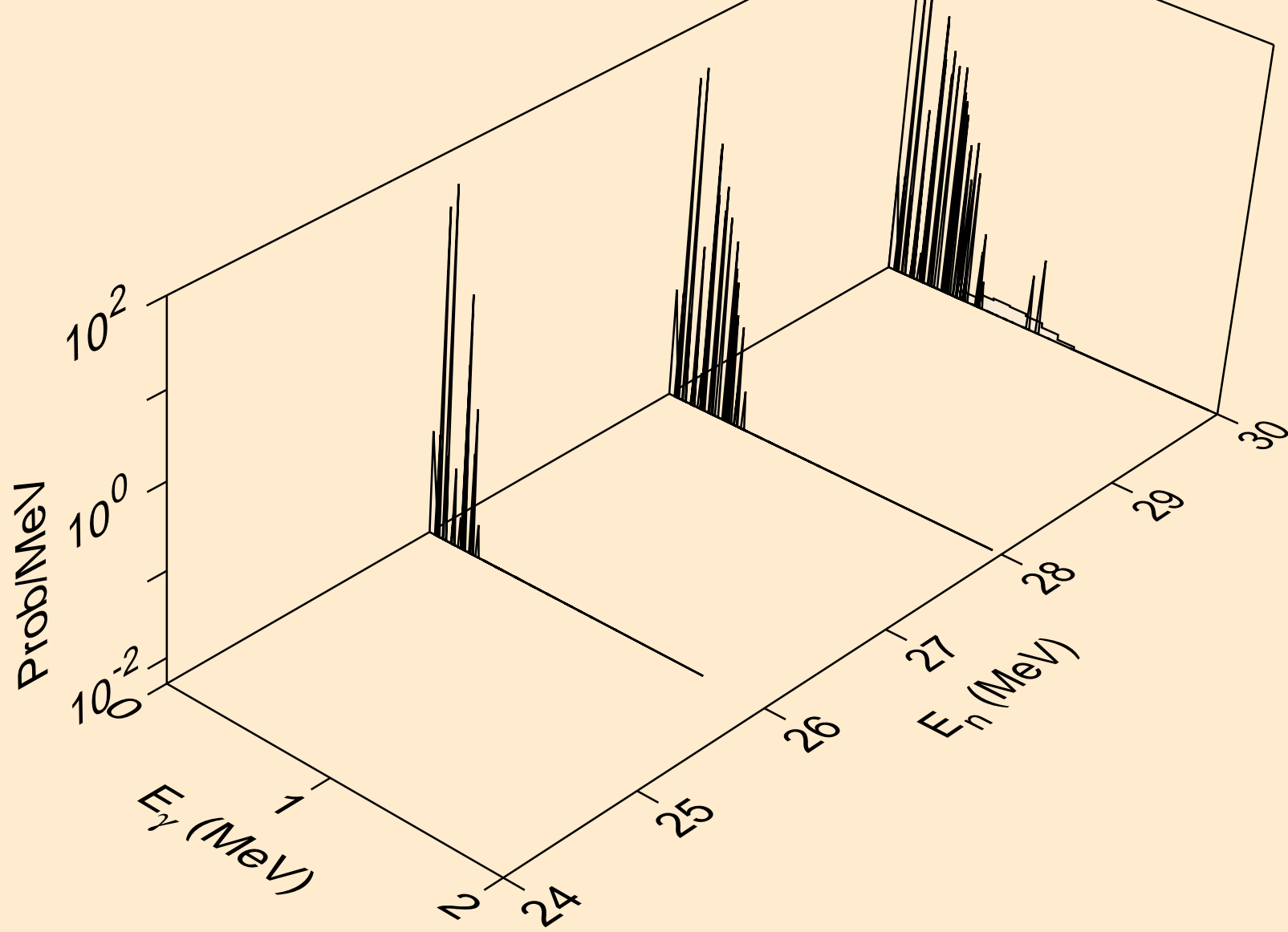

LU166N ALPHA ACER TENDL-2024 LIBRARY; T=0.K  
Photon emission for (n,n2p)

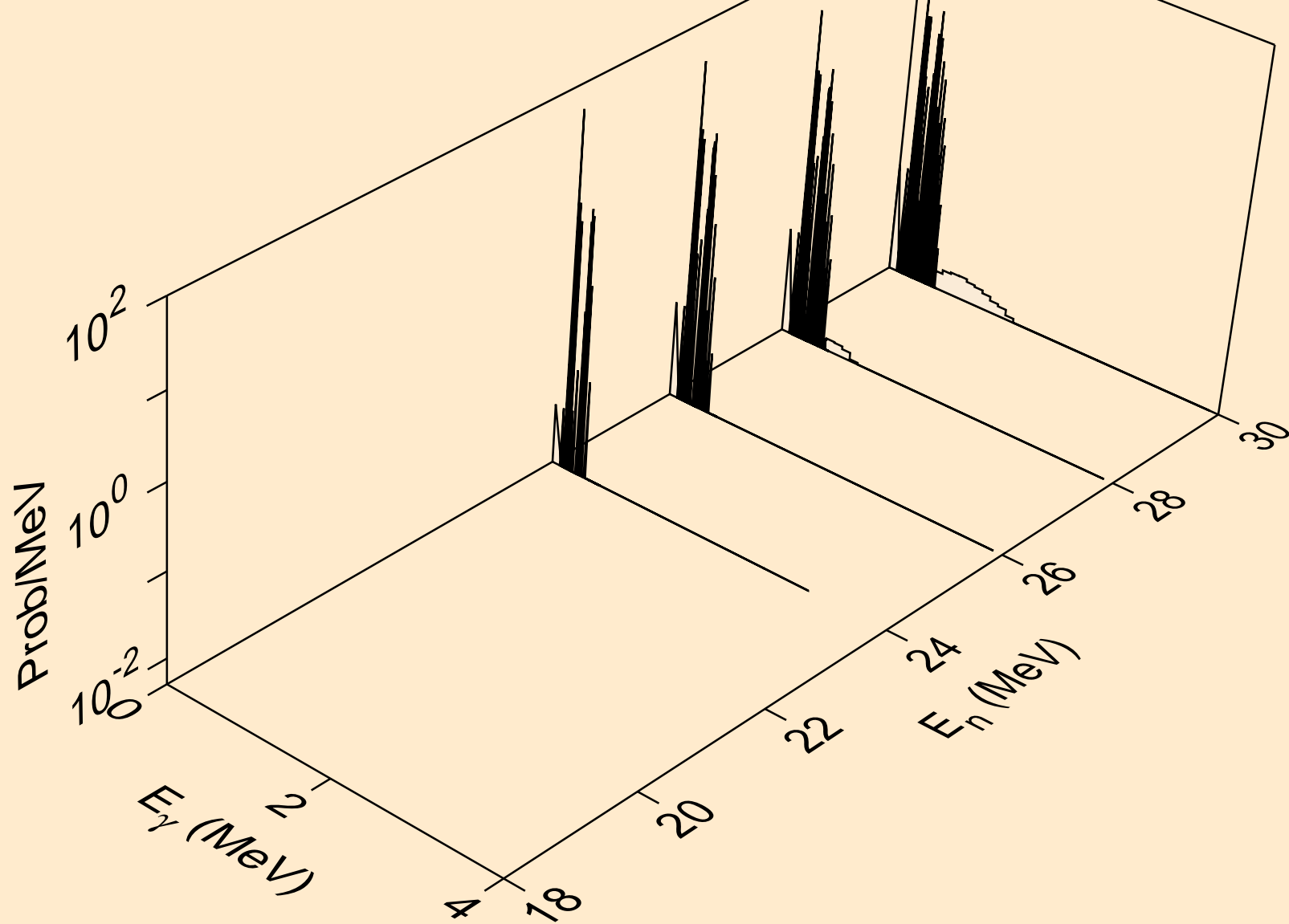

LU166N ALPHA ACER TENDL-2024 LIBRARY; T=0.K  
Photon emission for (n,npa)

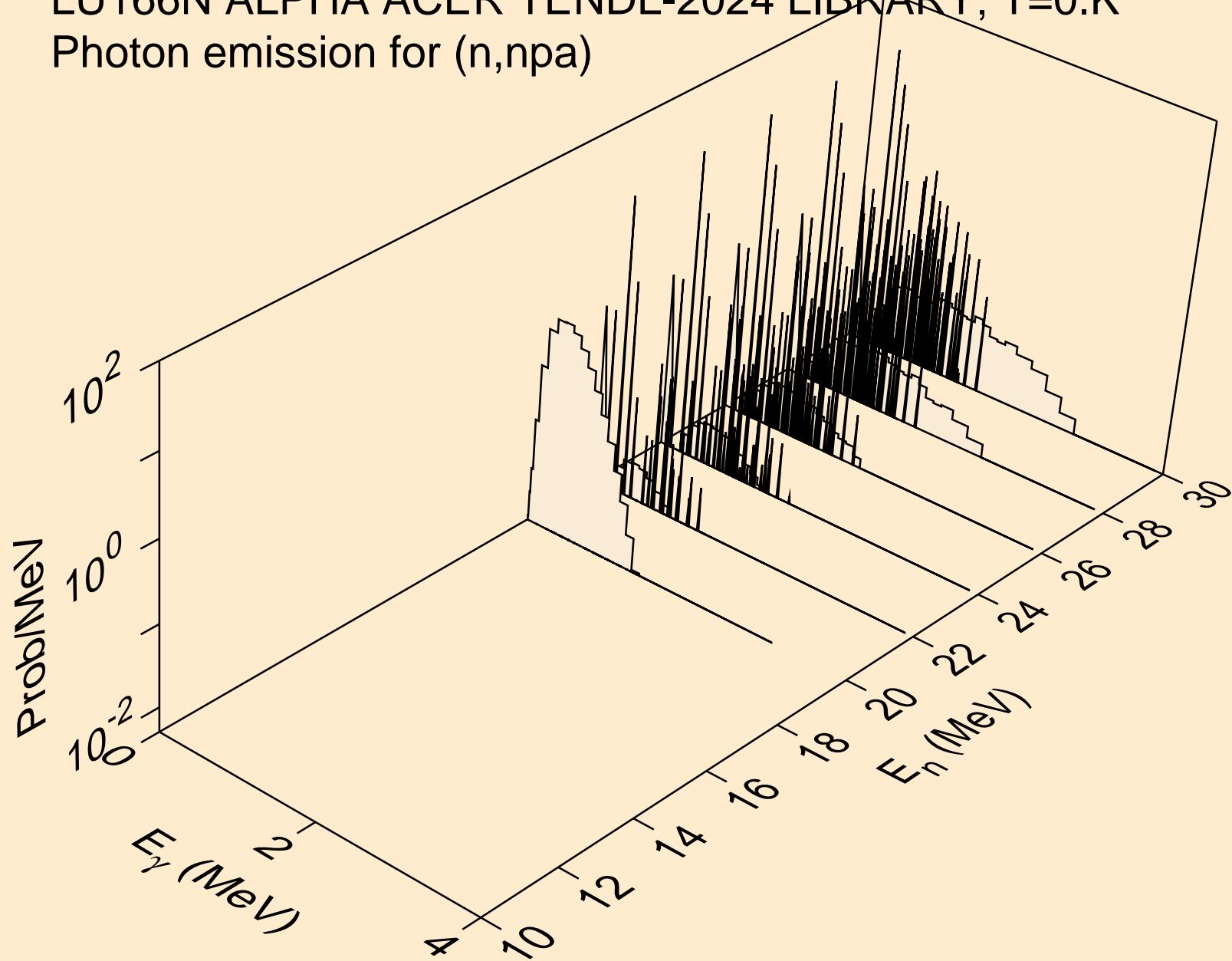

LU166N ALPHA ACER TENDL-2024 LIBRARY; T=0.K  
Photon emission for (n,gma)

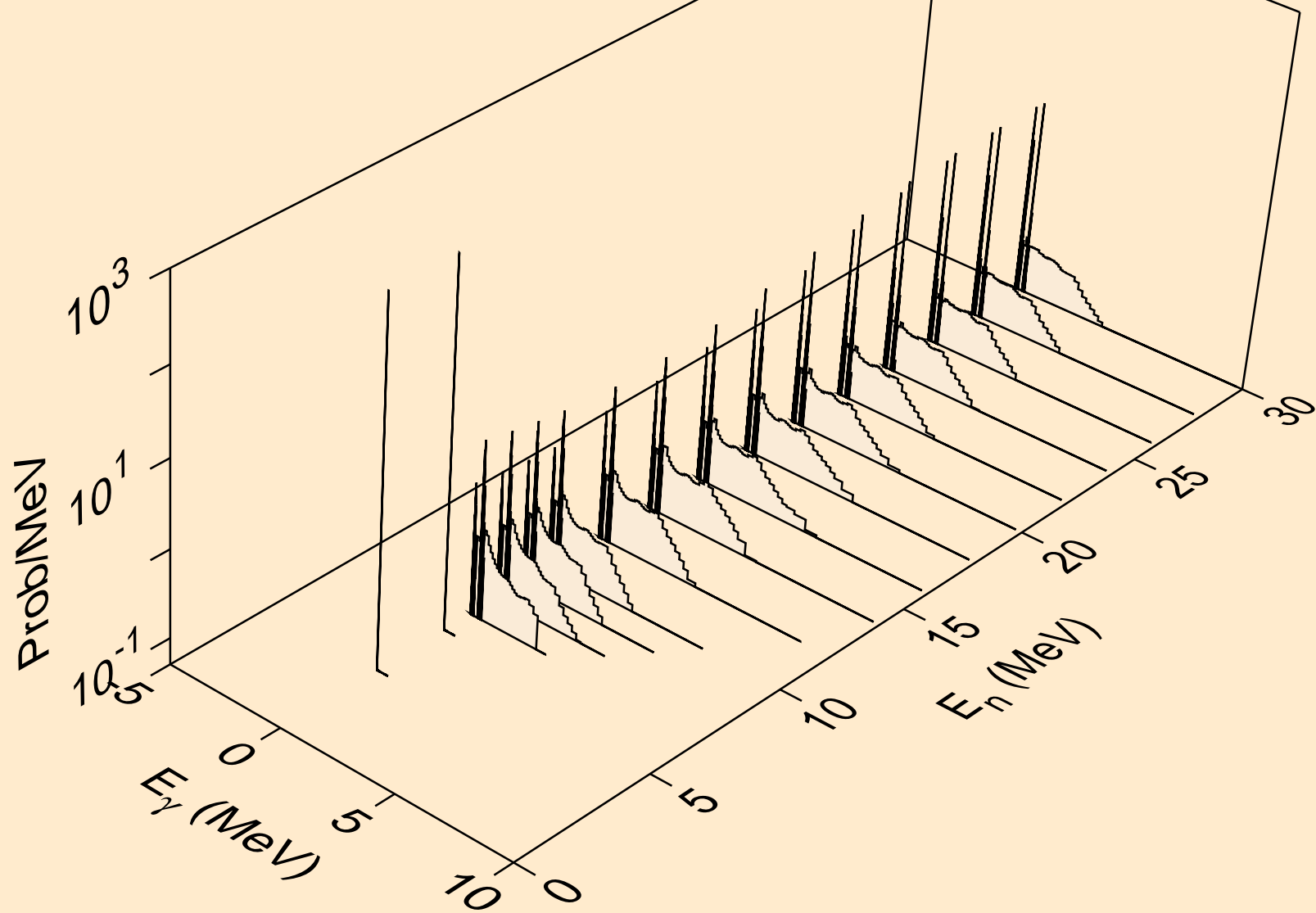

LU166N ALPHA ACER TENDL-2024 LIBRARY; T=0.K  
Photon emission for (n,p)

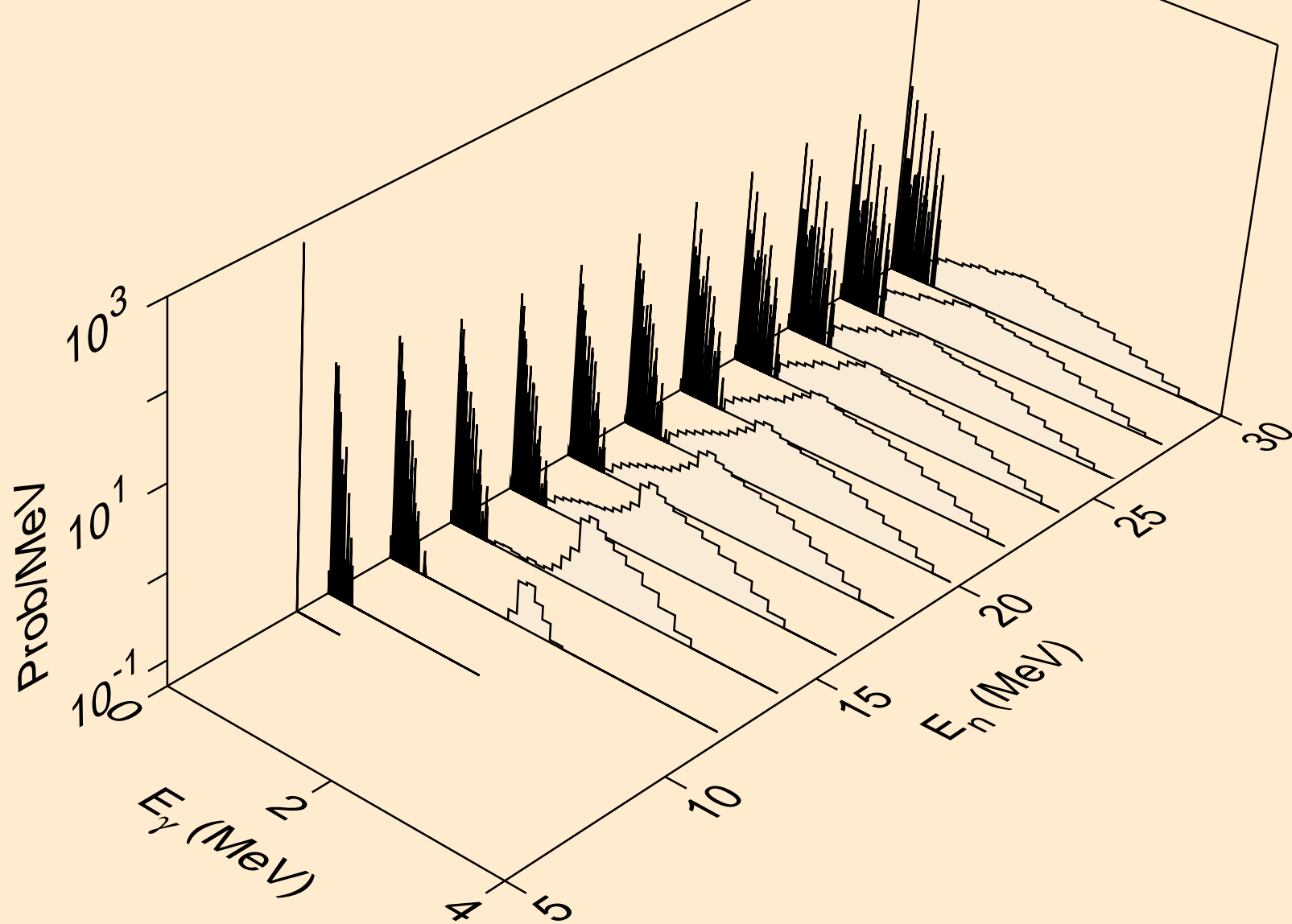

LU166N ALPHA ACER TENDL-2024 LIBRARY; T=0.K  
Photon emission for (n,d)

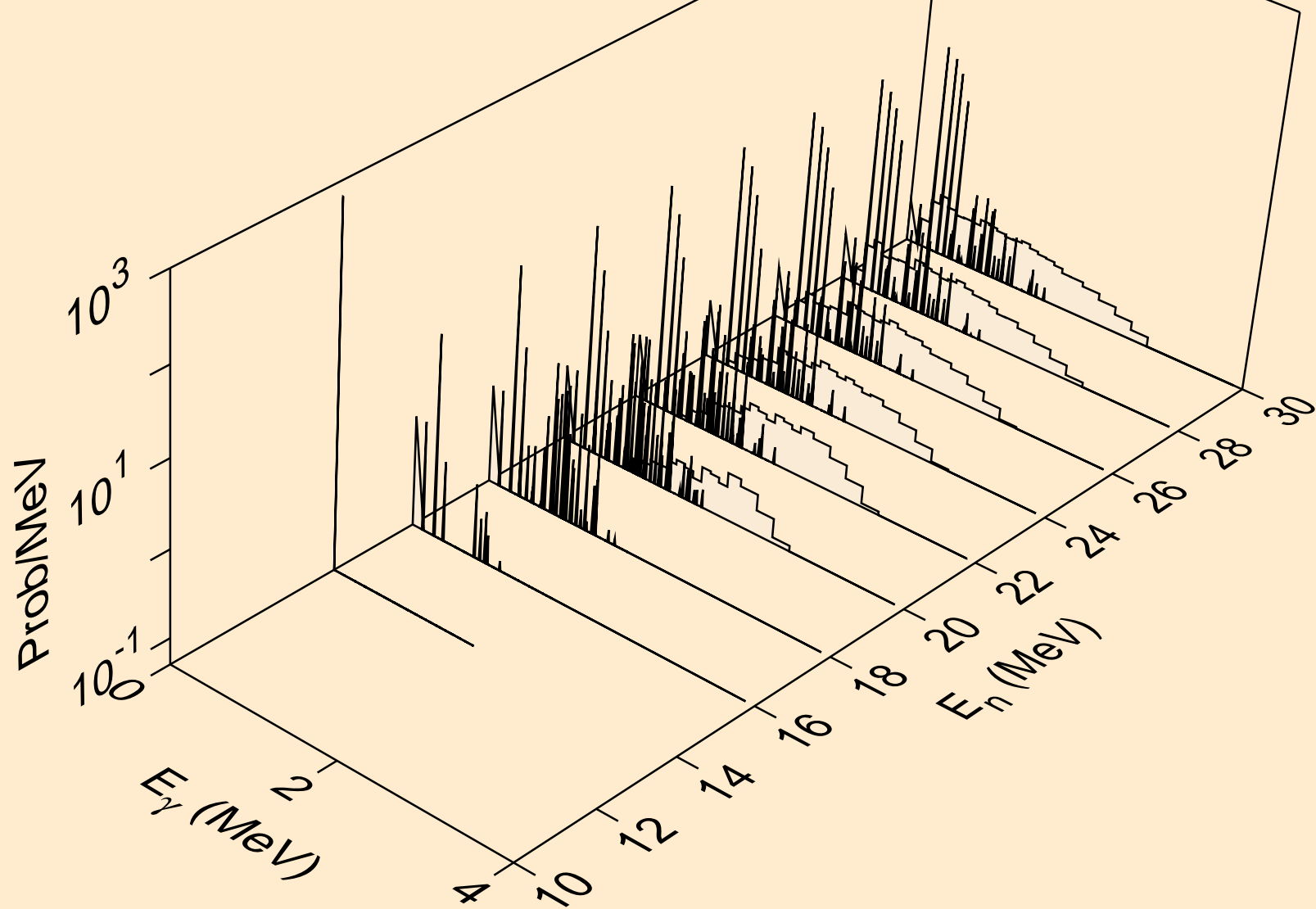

LU166N ALPHA ACER TENDL-2024 LIBRARY; T=0.K  
Photon emission for (n,t)

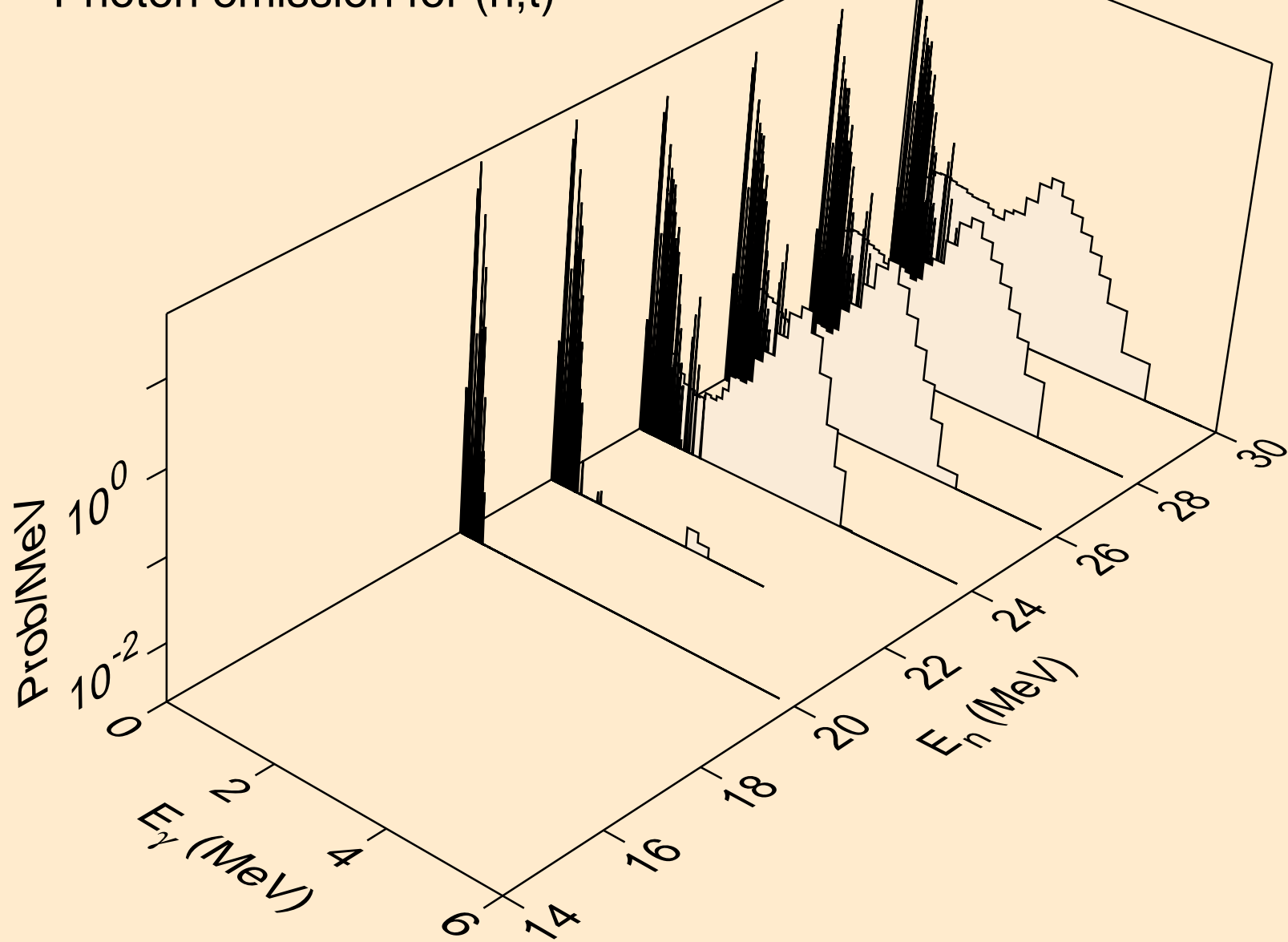

LU166N ALPHA ACER TENDL-2024 LIBRARY; T=0.K  
Photon emission for (n,he3)

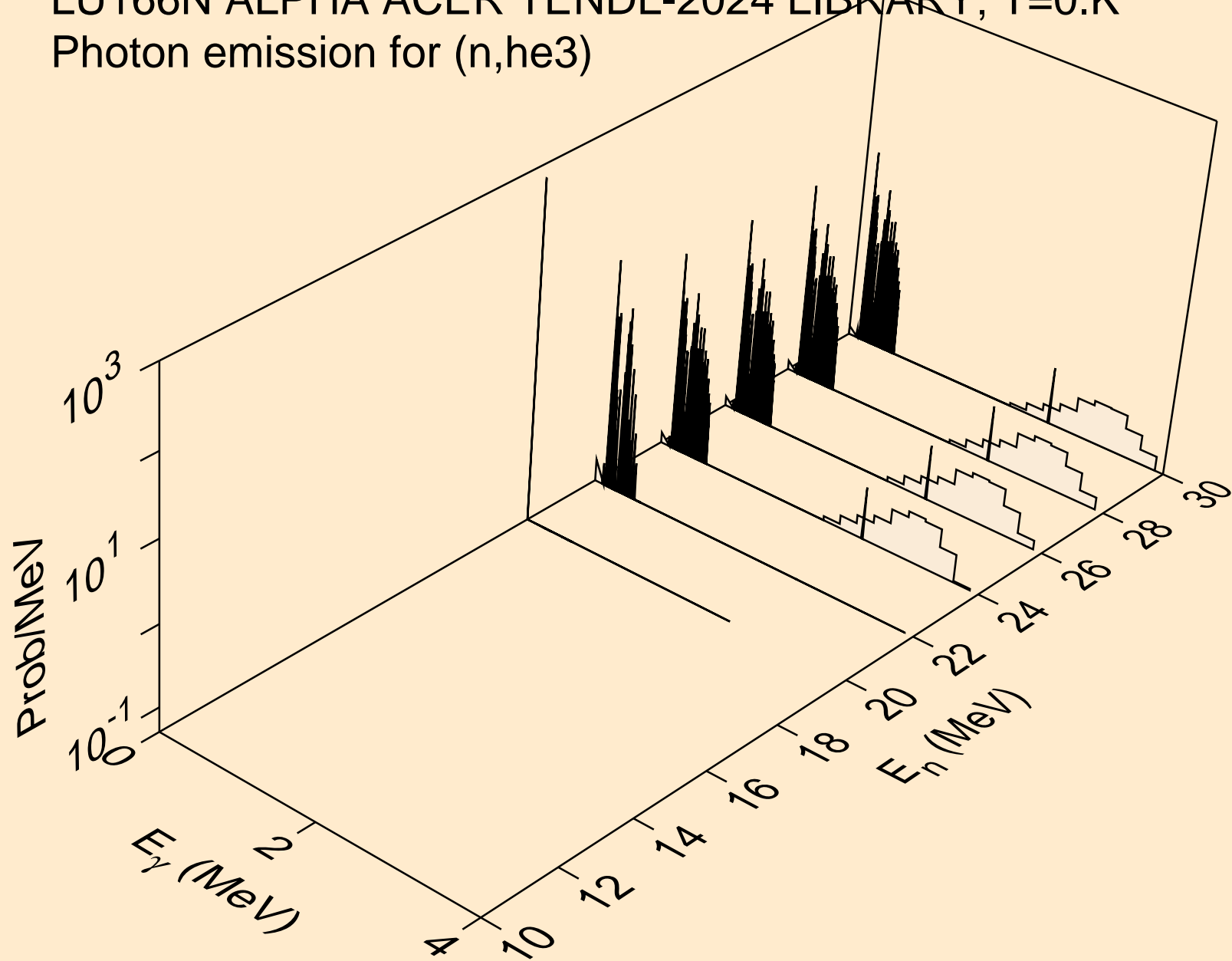

LU166N ALPHA ACER TENDL-2024 LIBRARY; T=0.K  
Photon emission for inelastic

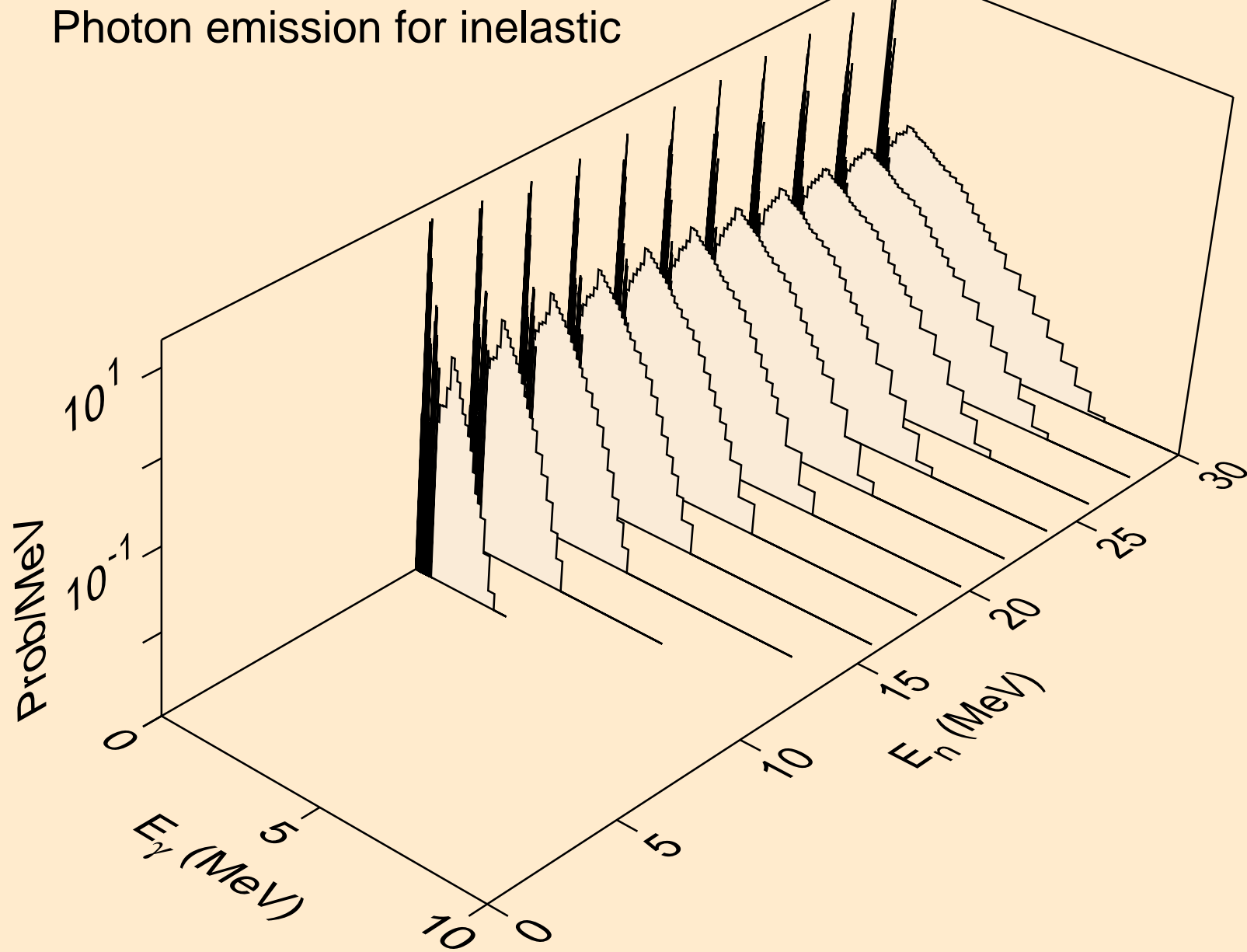

LU166N ALPHA ACER TENDL-2024 LIBRARY; T=0.K  
Photon emission for (n,2a)

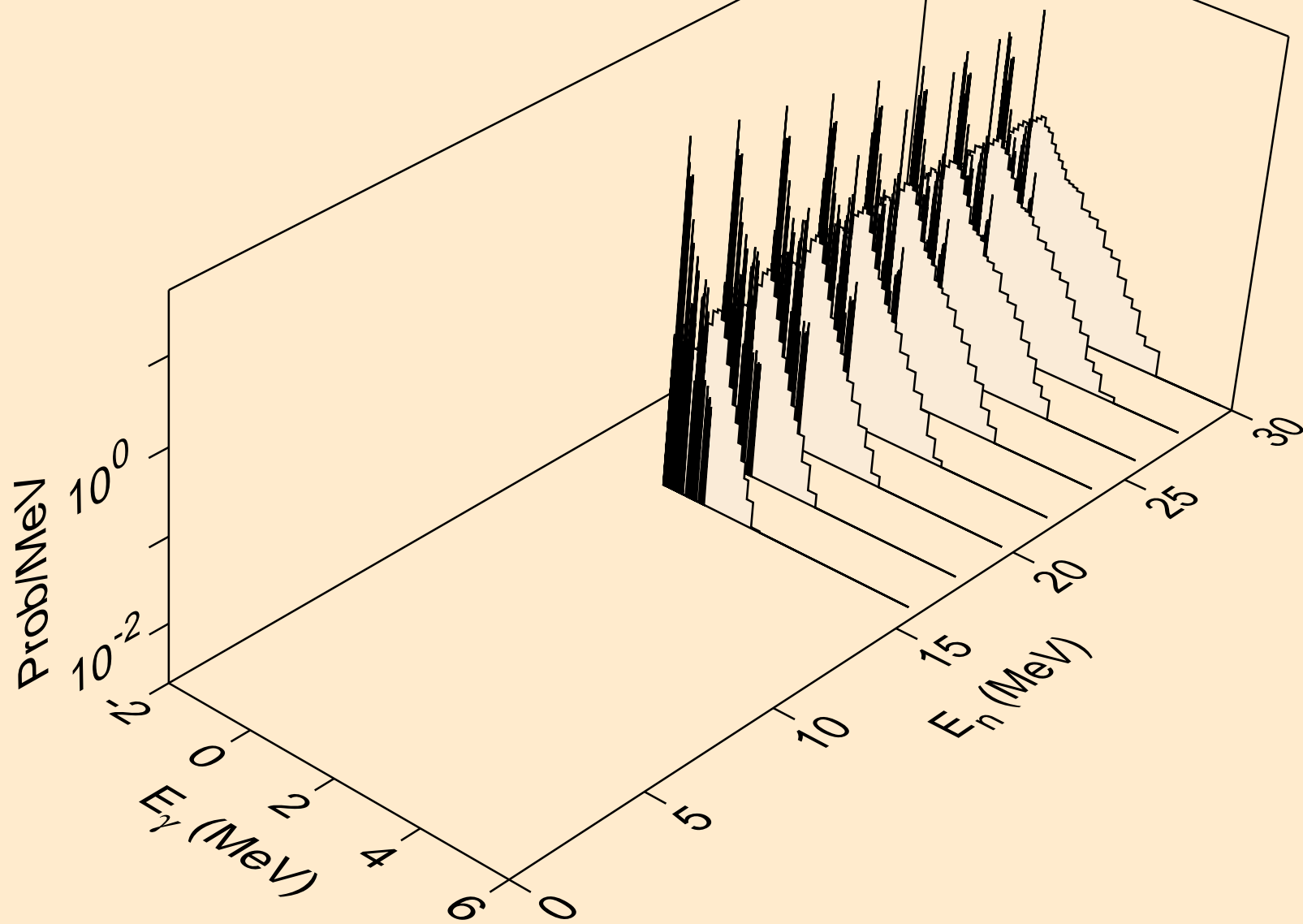

LU166N ALPHA ACER TENDL-2024 LIBRARY; T=0.K  
Photon emission for (n,2p)

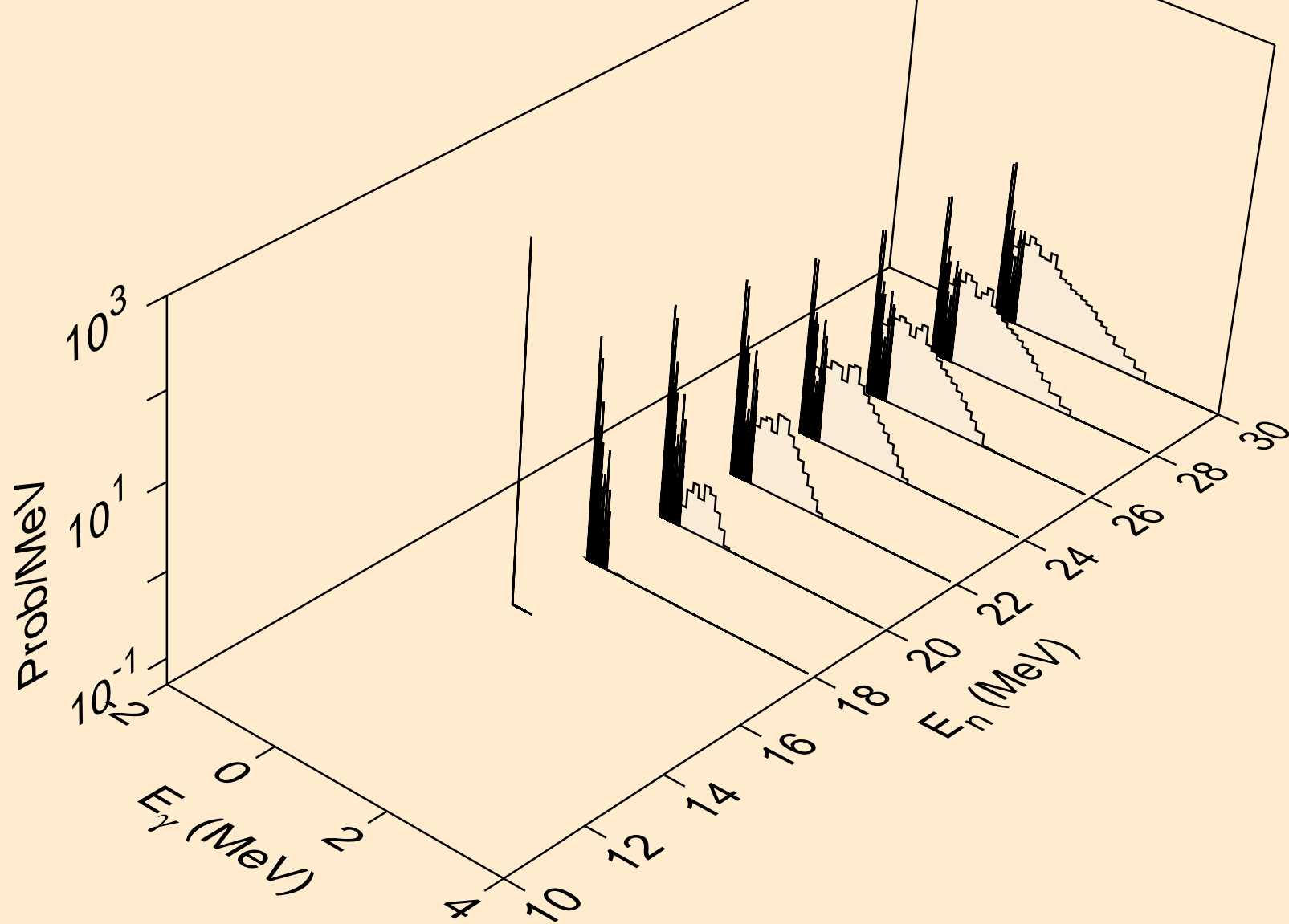

LU166N ALPHA ACER TENDL-2024 LIBRARY; T=0.K  
Photon emission for (n,pa)

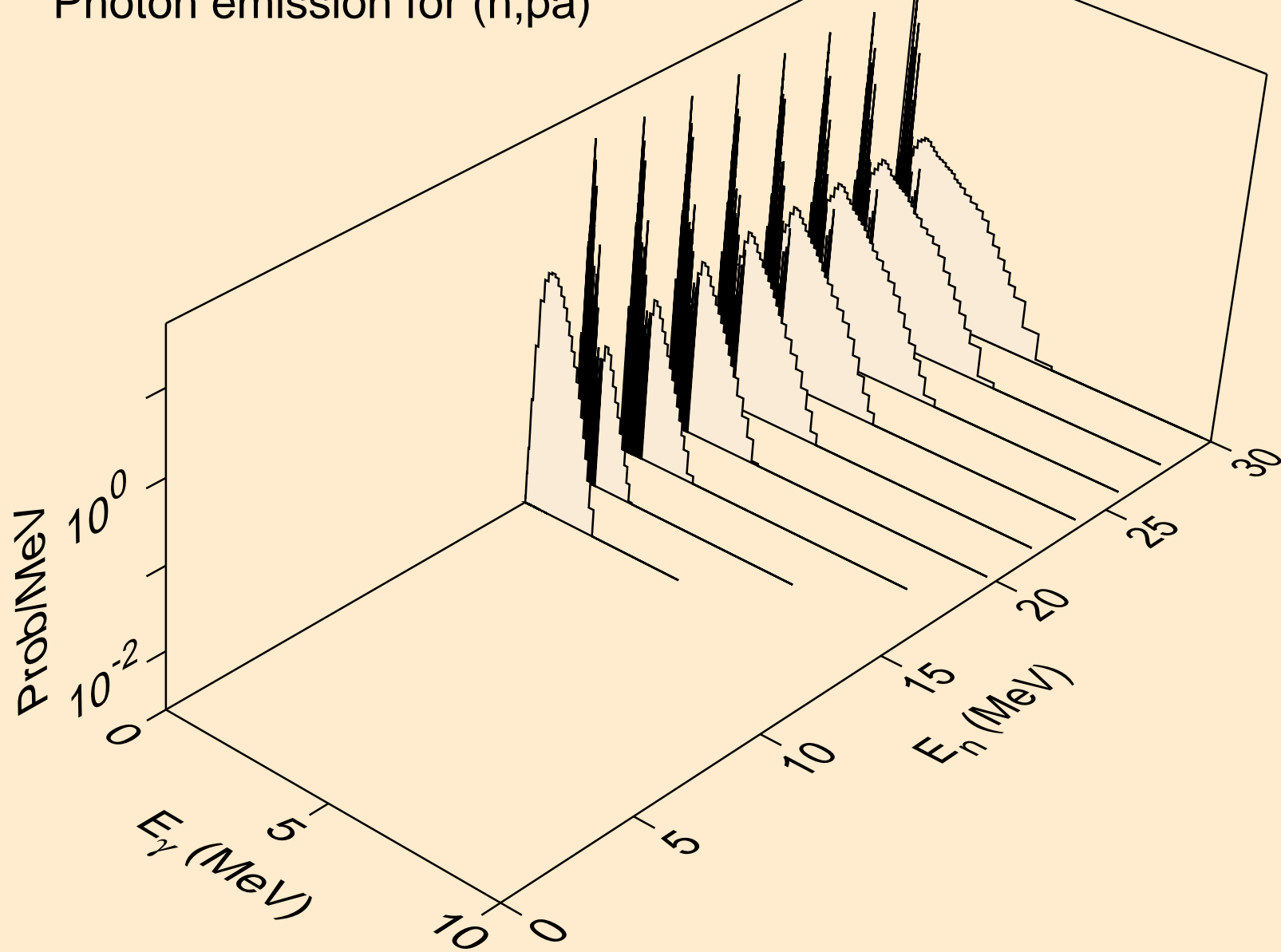

LU166N ALPHA ACER TENDL-2024 LIBRARY; T=0.K  
Photon emission for (n,pd)

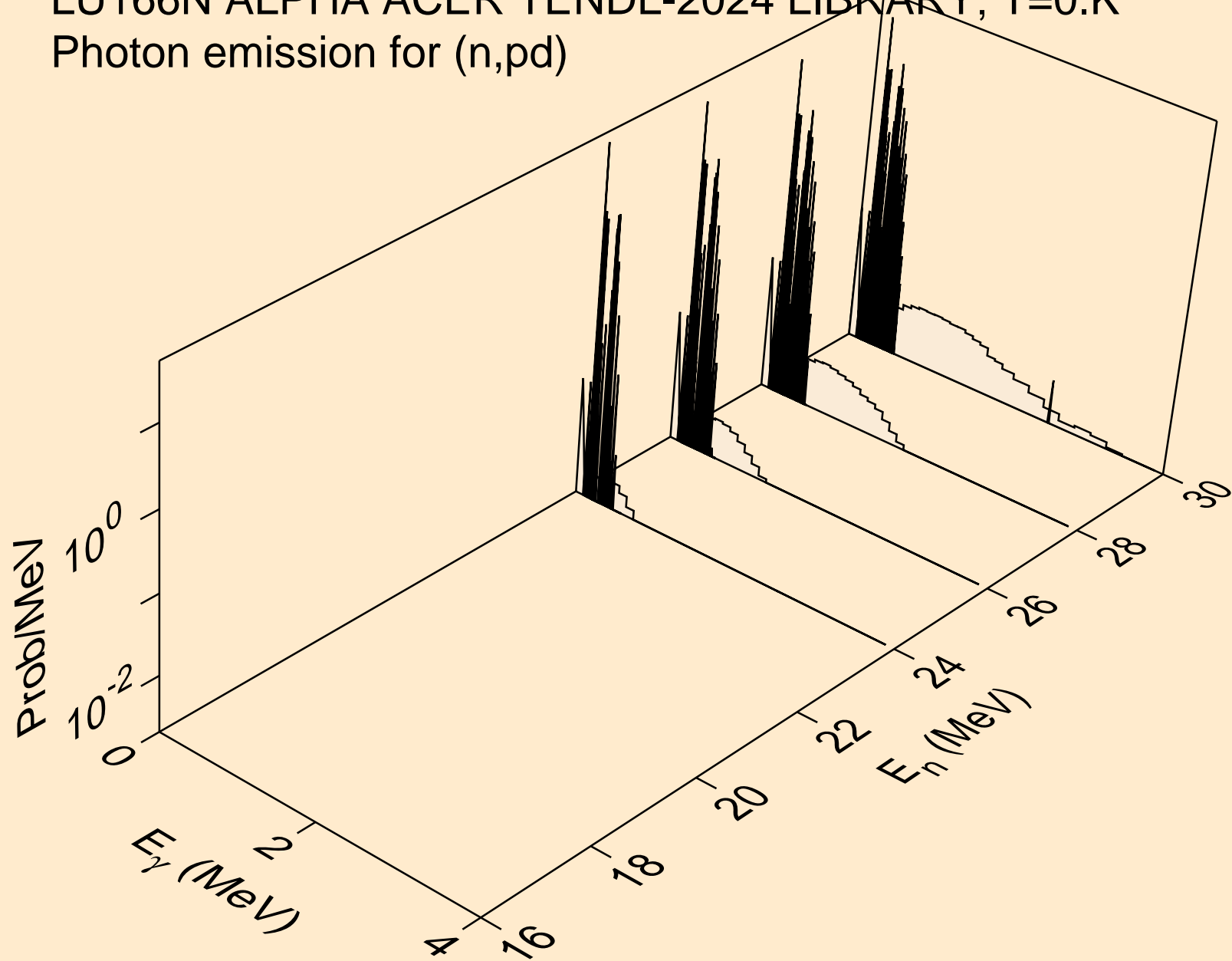

LU166N ALPHA ACER TENDL-2024 LIBRARY; T=0.K  
Photon emission for (n,da)

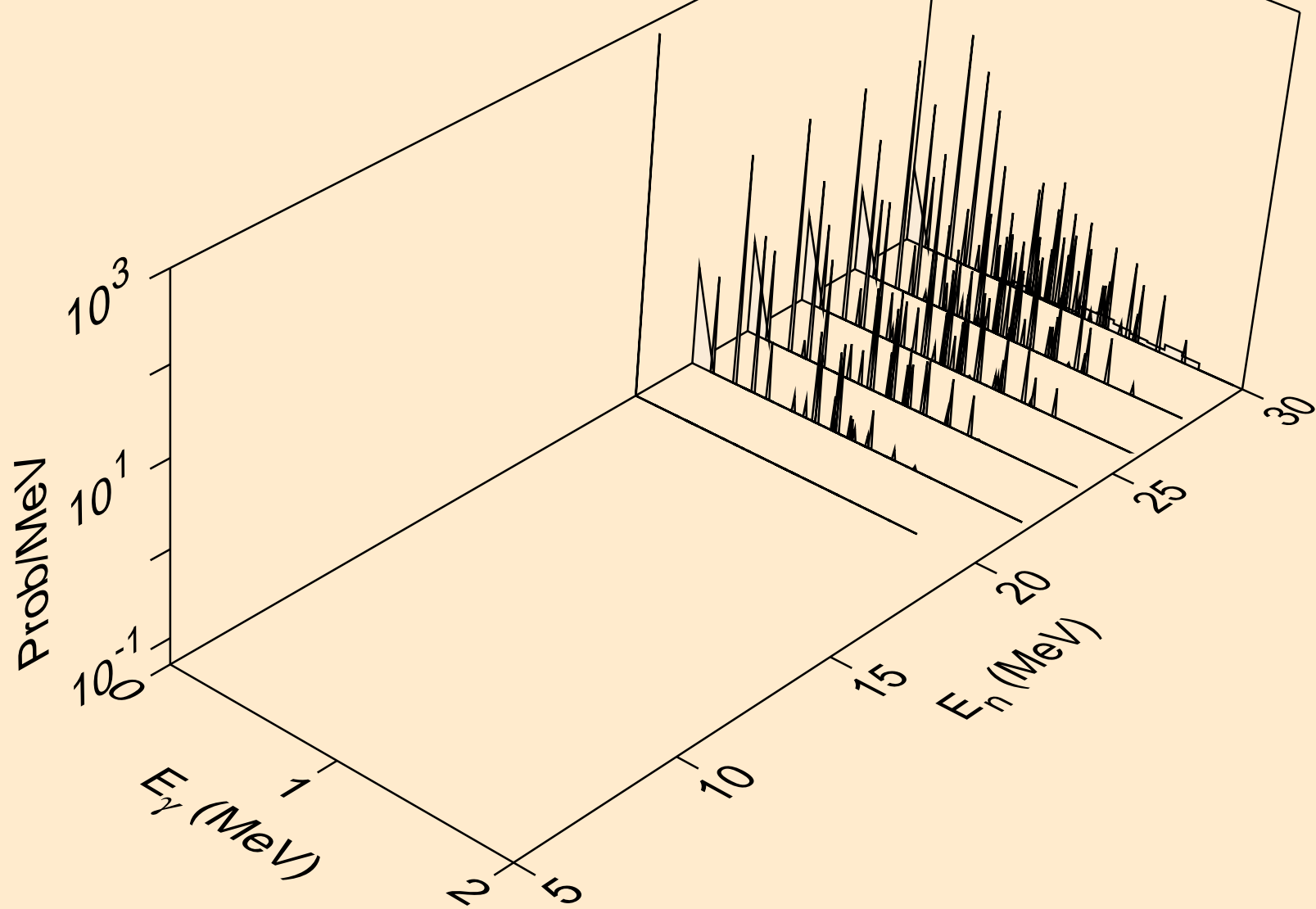

LU166N ALPHA ACER TENDL-2024 LIBRARY; T=0.K  
Particle heating contributions

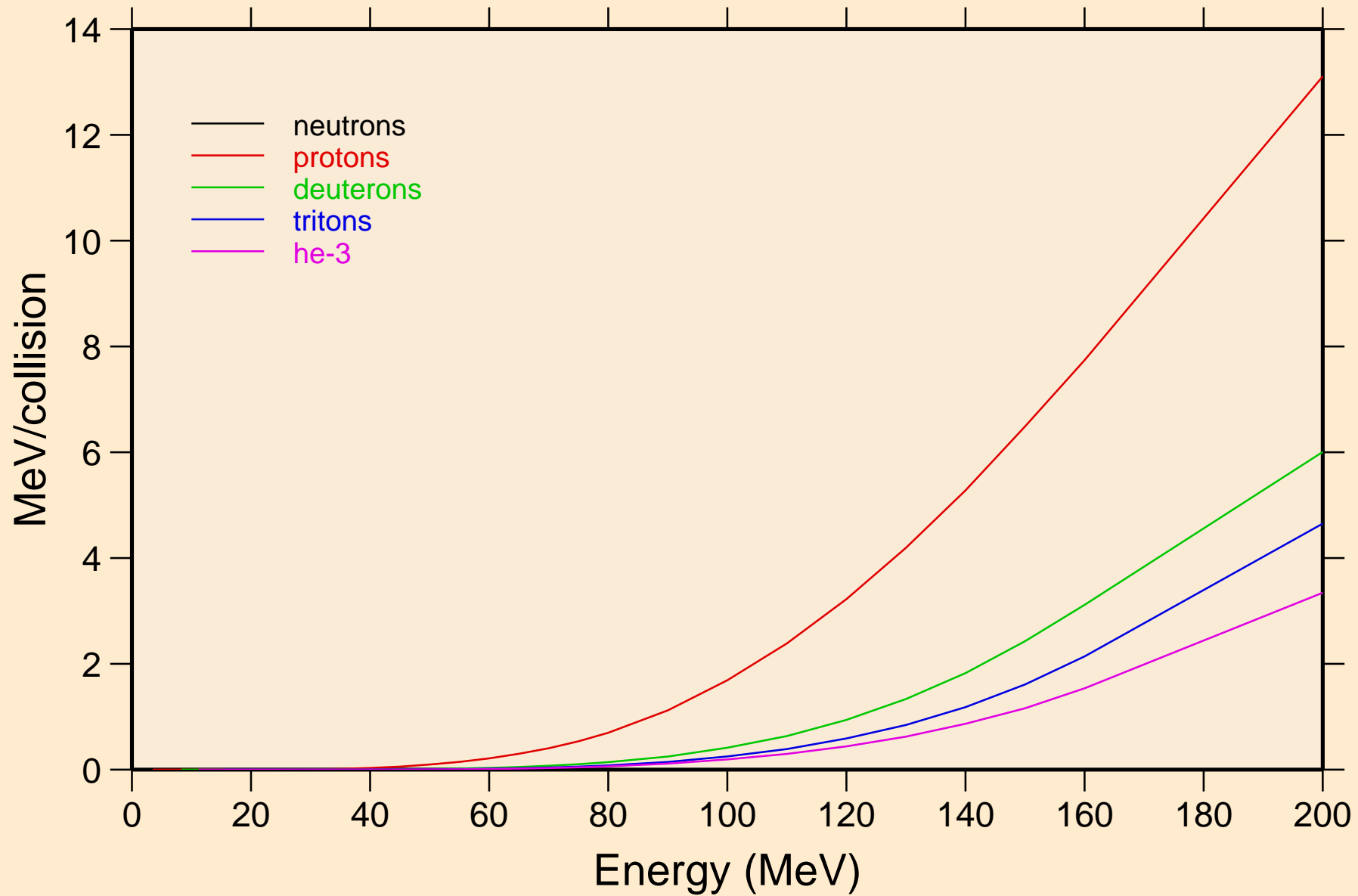

LU166N ALPHA ACER TENDL-2024 LIBRARY; T=0.K  
Recoil Heating

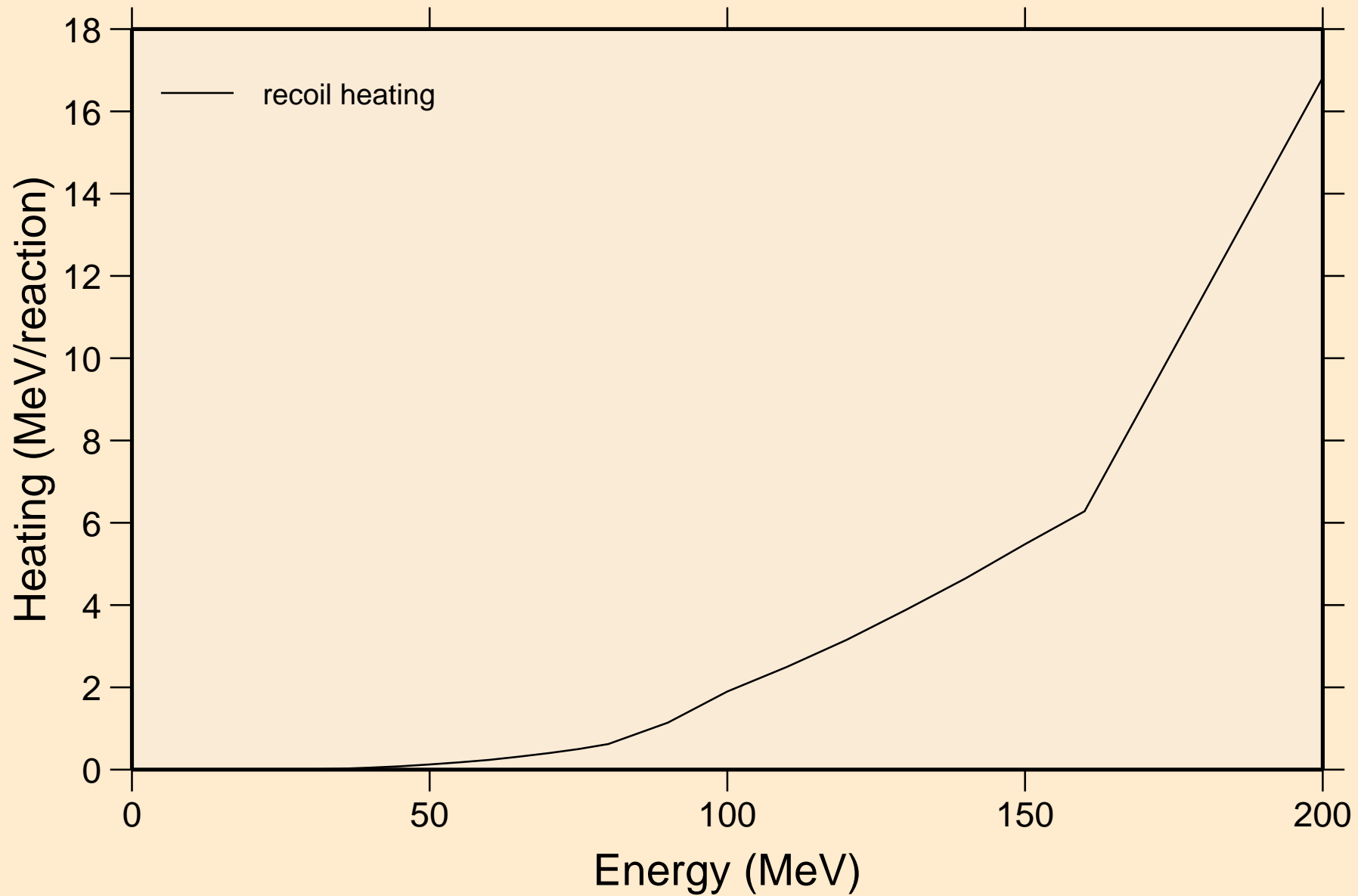

LU166N ALPHA ACER TENDL-2024 LIBRARY; T=0.K  
Particle production cross sections

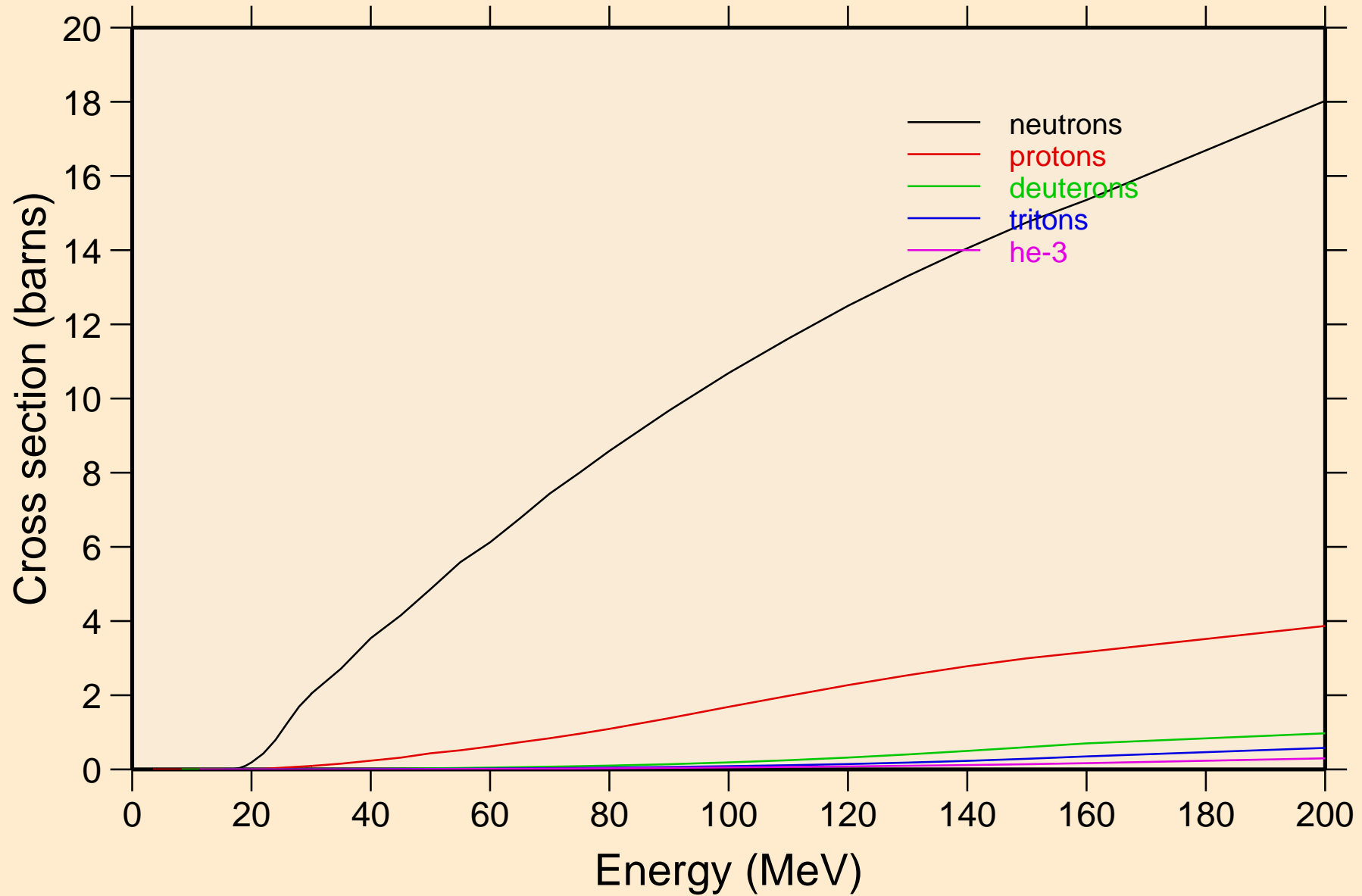

LU166N ALPHA ACER TENDL-2024 LIBRARY; T=0.K  
neutrons from (a,n)

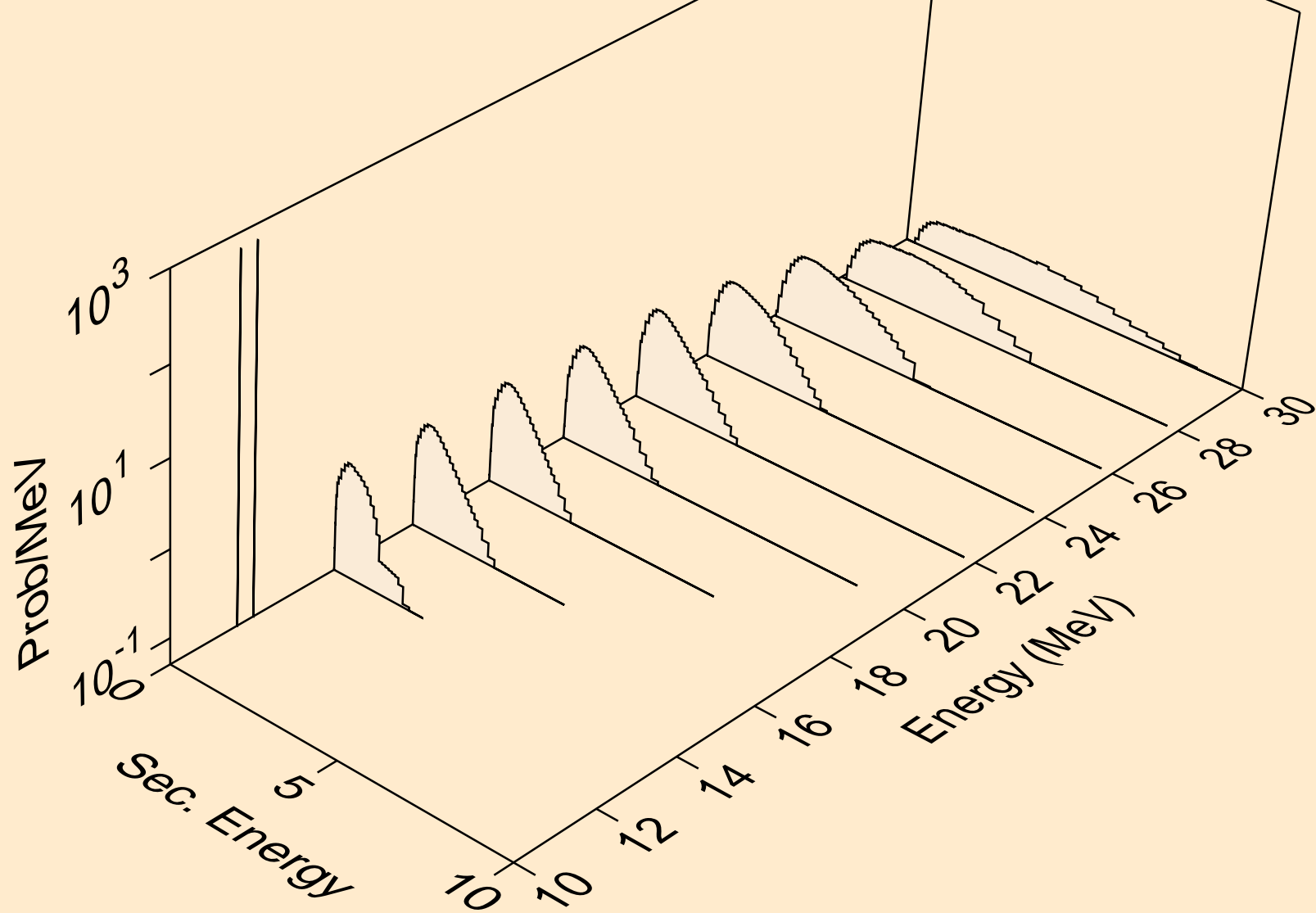

LU166N ALPHA ACER TENDL-2024 LIBRARY; T=0.K  
neutrons from (a,x)

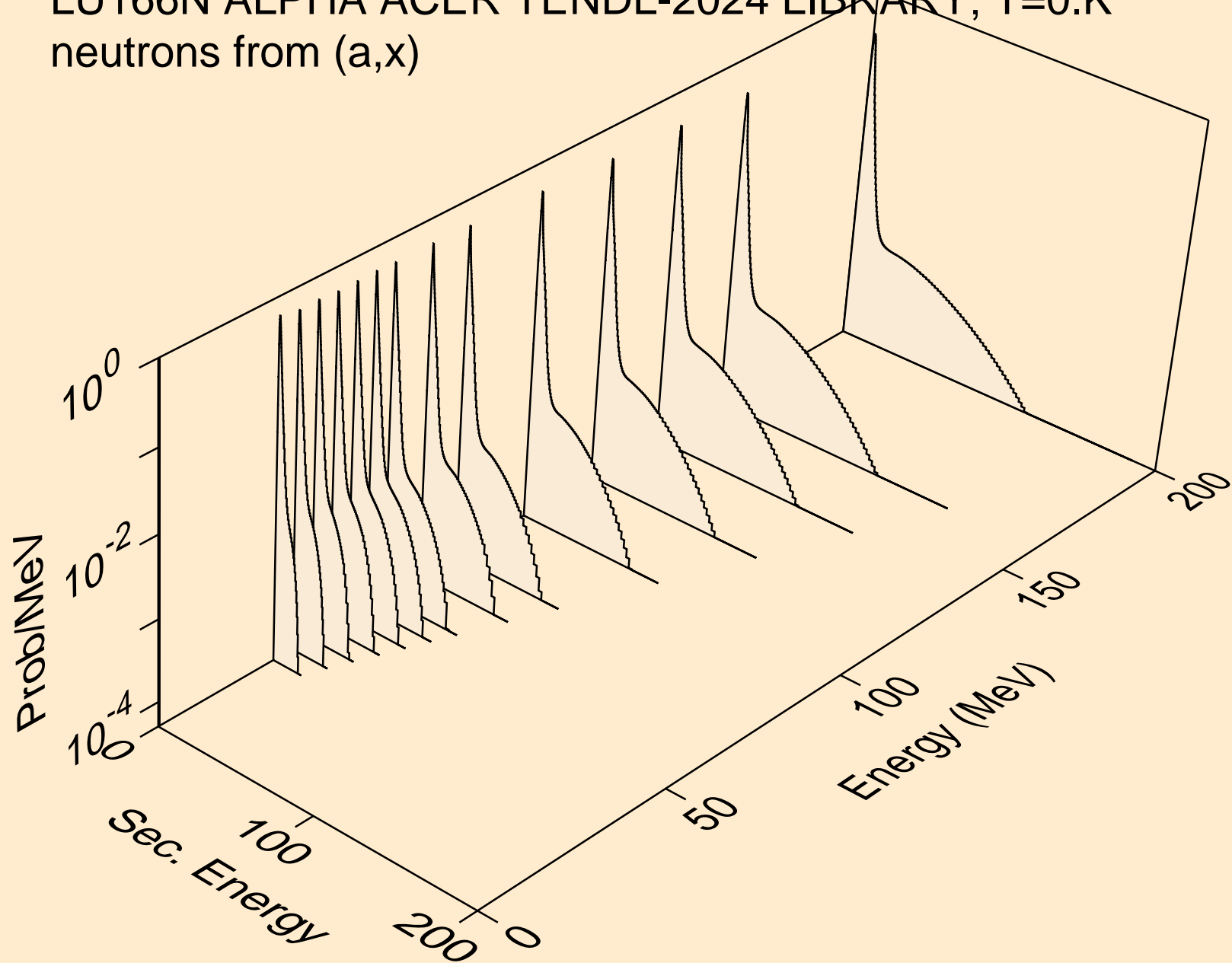

LU166N ALPHA ACER TENDL-2024 LIBRARY; T=0.K  
neutrons from (a,2n)

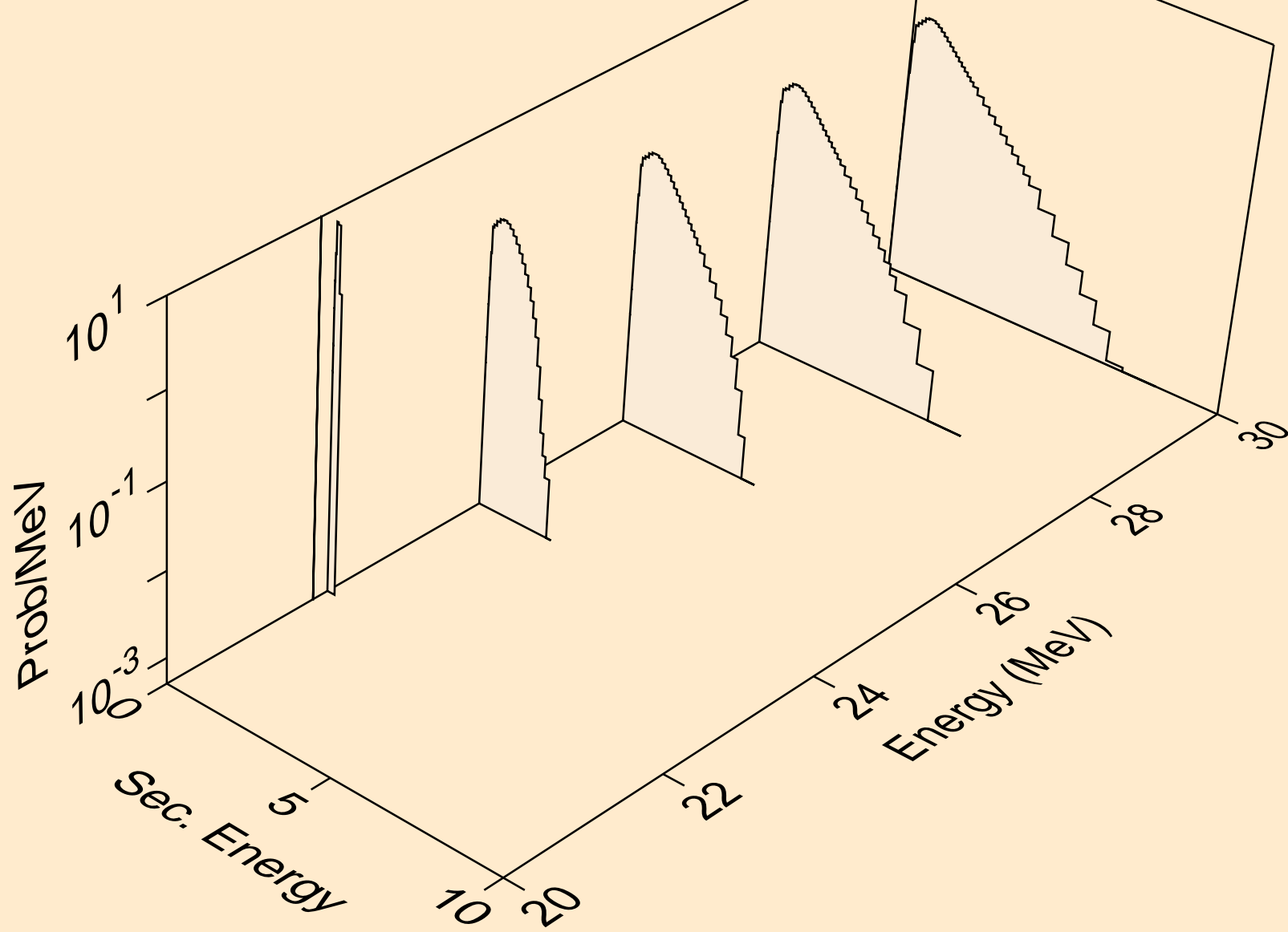

LU166N ALPHA ACER TENDL-2024 LIBRARY; T=0.K  
neutrons from (a,n\*)a

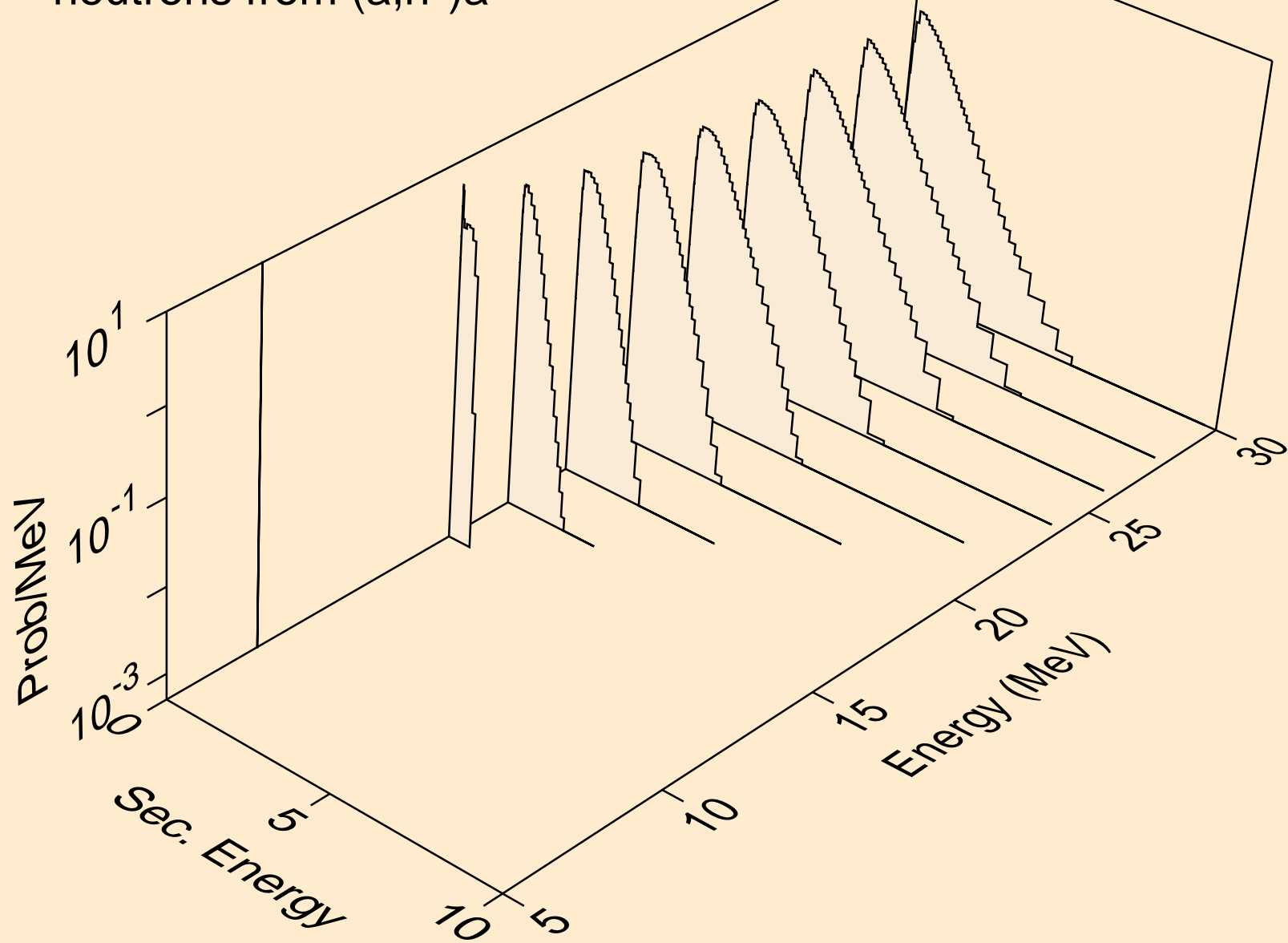

LU166N ALPHA ACER TENDL-2024 LIBRARY; T=0.K  
neutrons from (a,2n)a

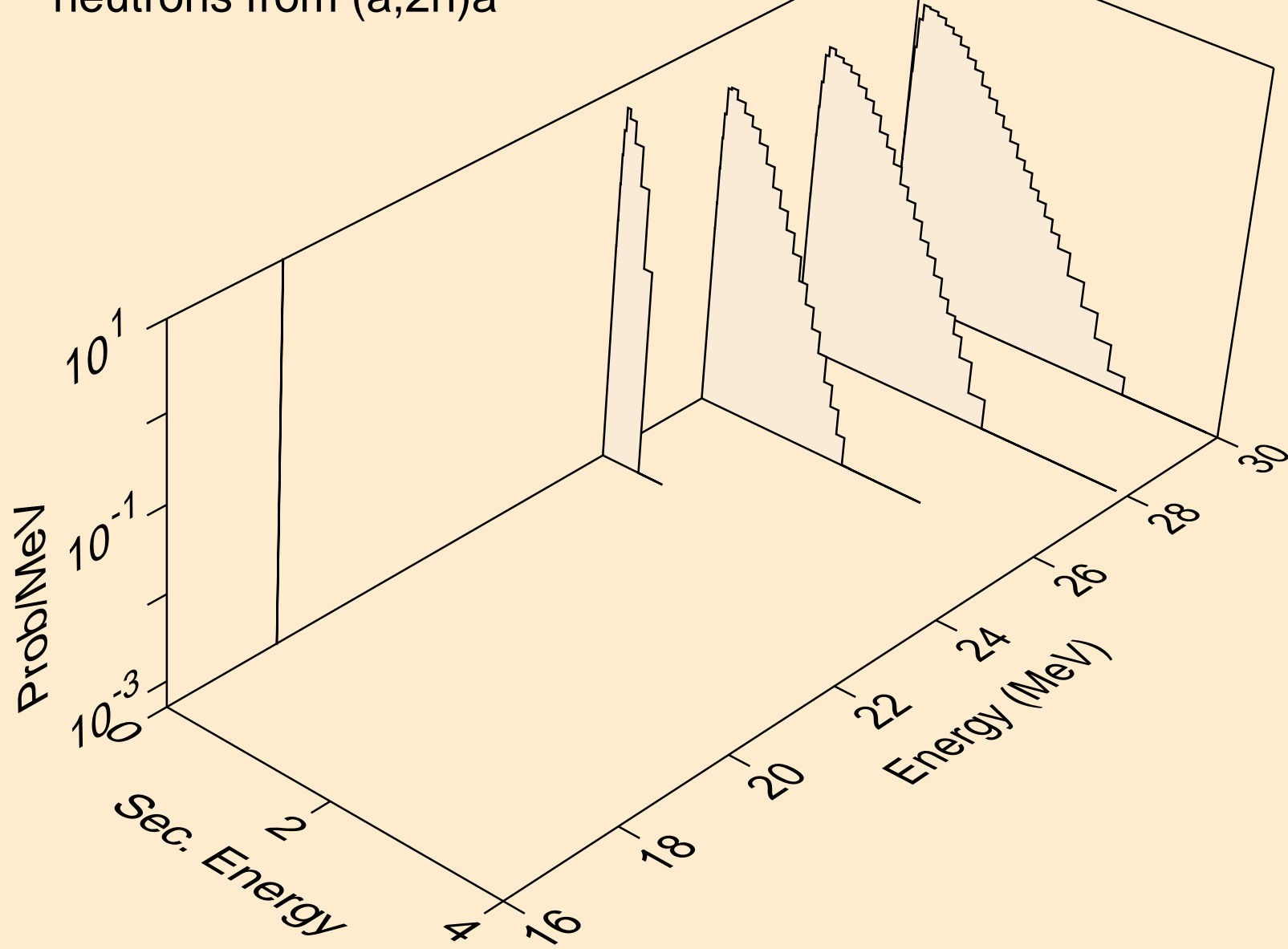

LU166N ALPHA ACER TENDL-2024 LIBRARY; T=0.K  
neutrons from (a,n\*)p

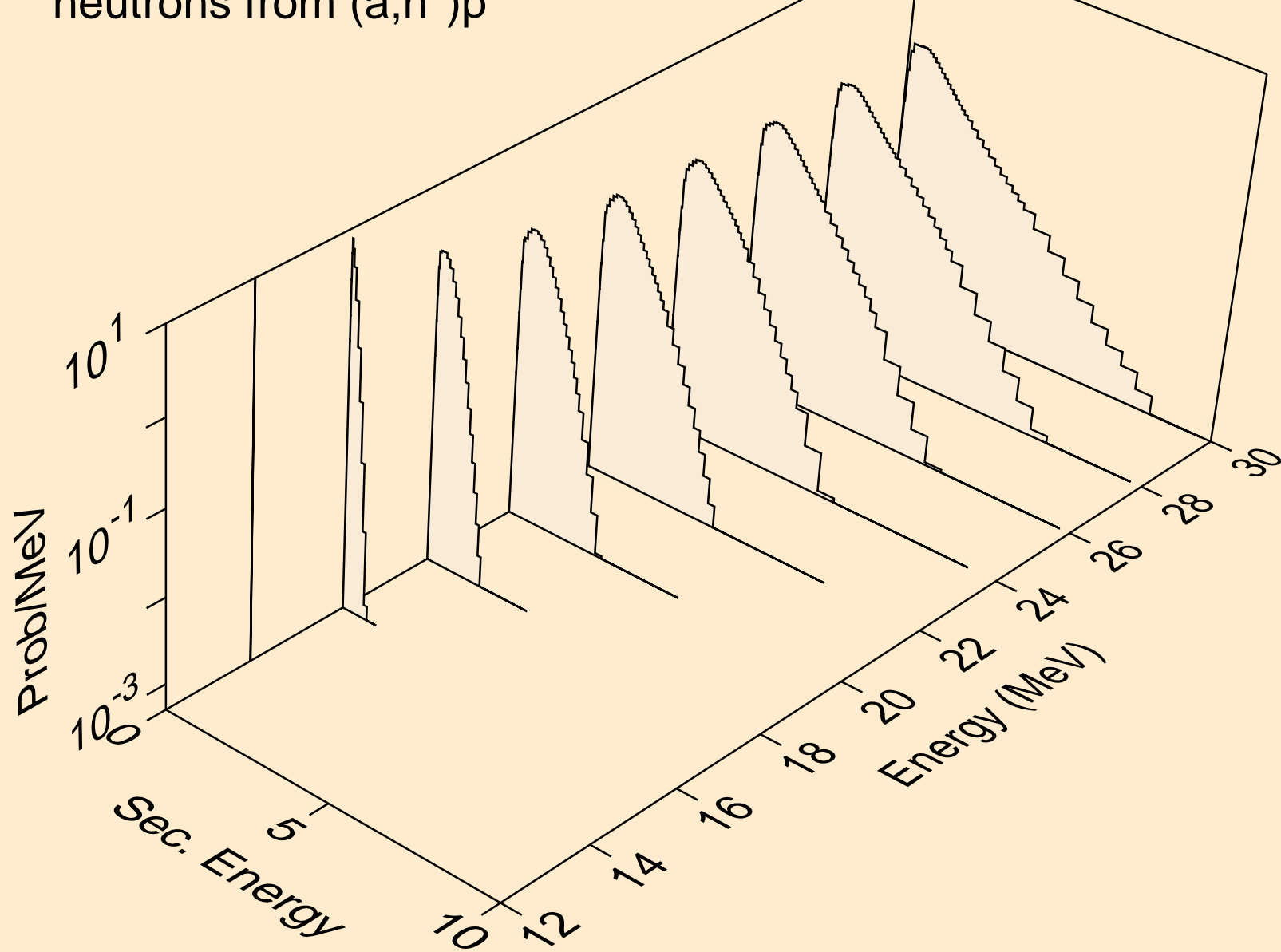

LU166N ALPHA ACER TENDL-2024 LIBRARY; T=0.K  
neutrons from (a,n\*)2a

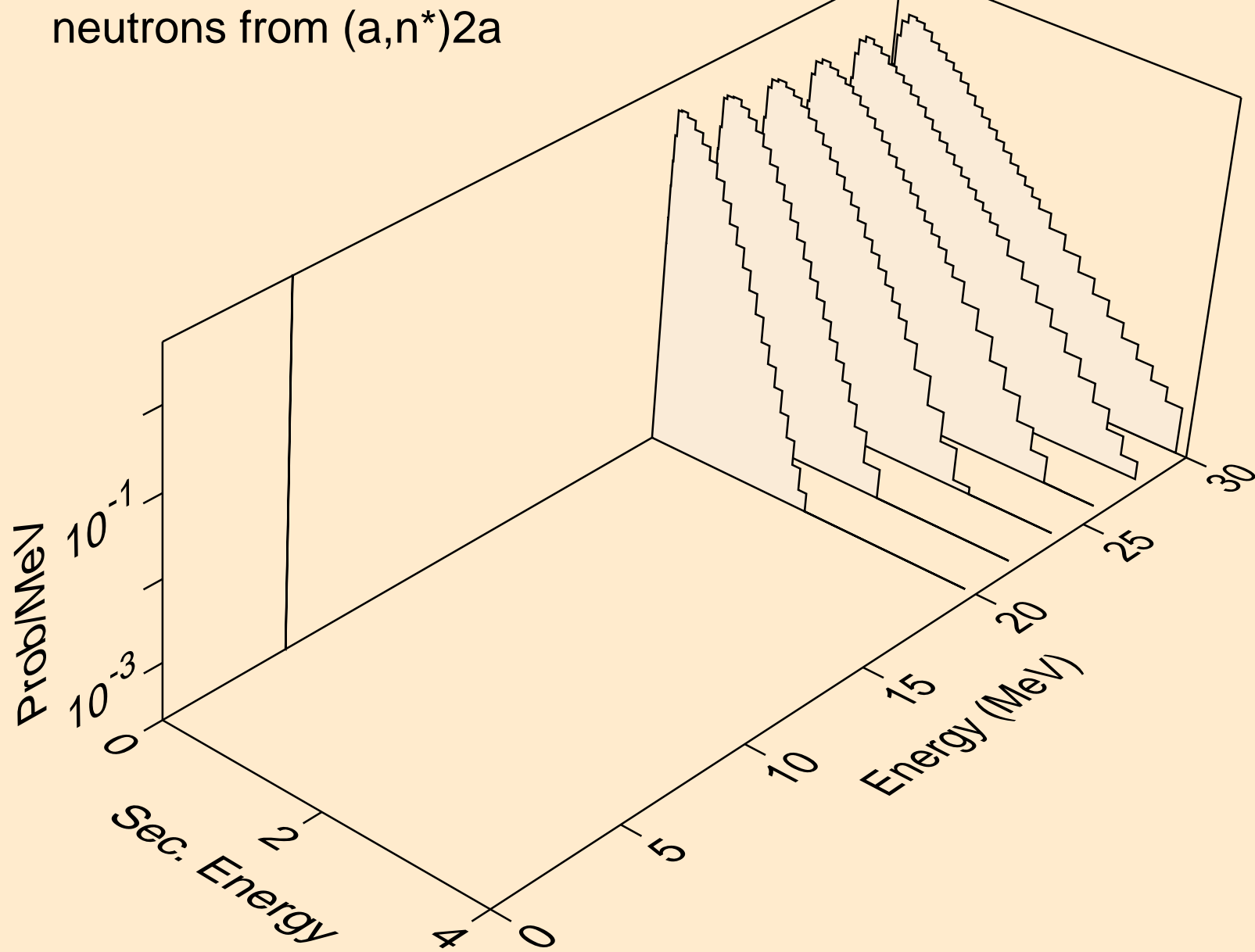

LU166N ALPHA ACER TENDL-2024 LIBRARY; T=0.K  
neutrons from (a,n\*)d

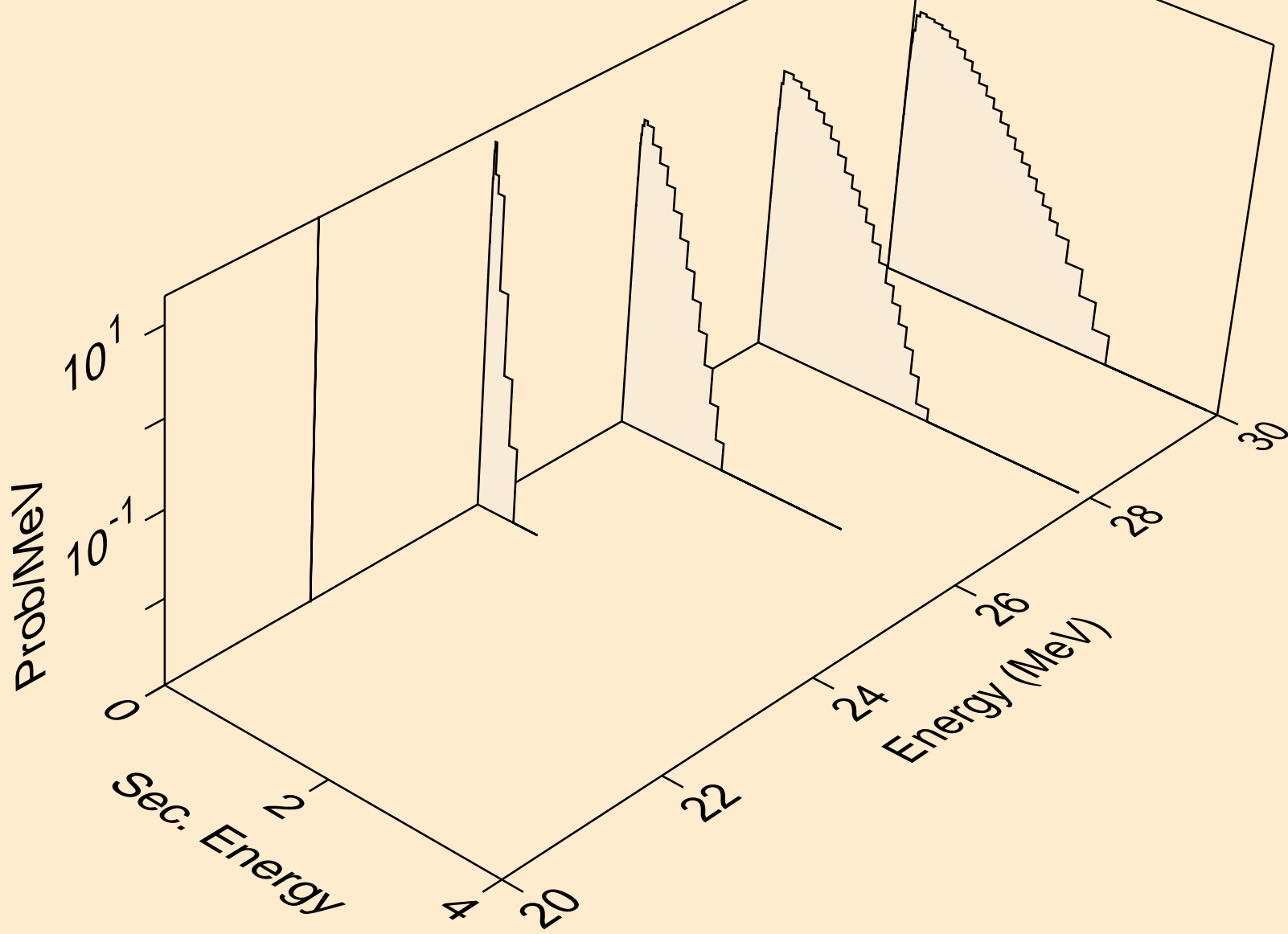

LU166N ALPHA ACER TENDL-2024 LIBRARY; T=0.K  
neutrons from (a,n\*)t

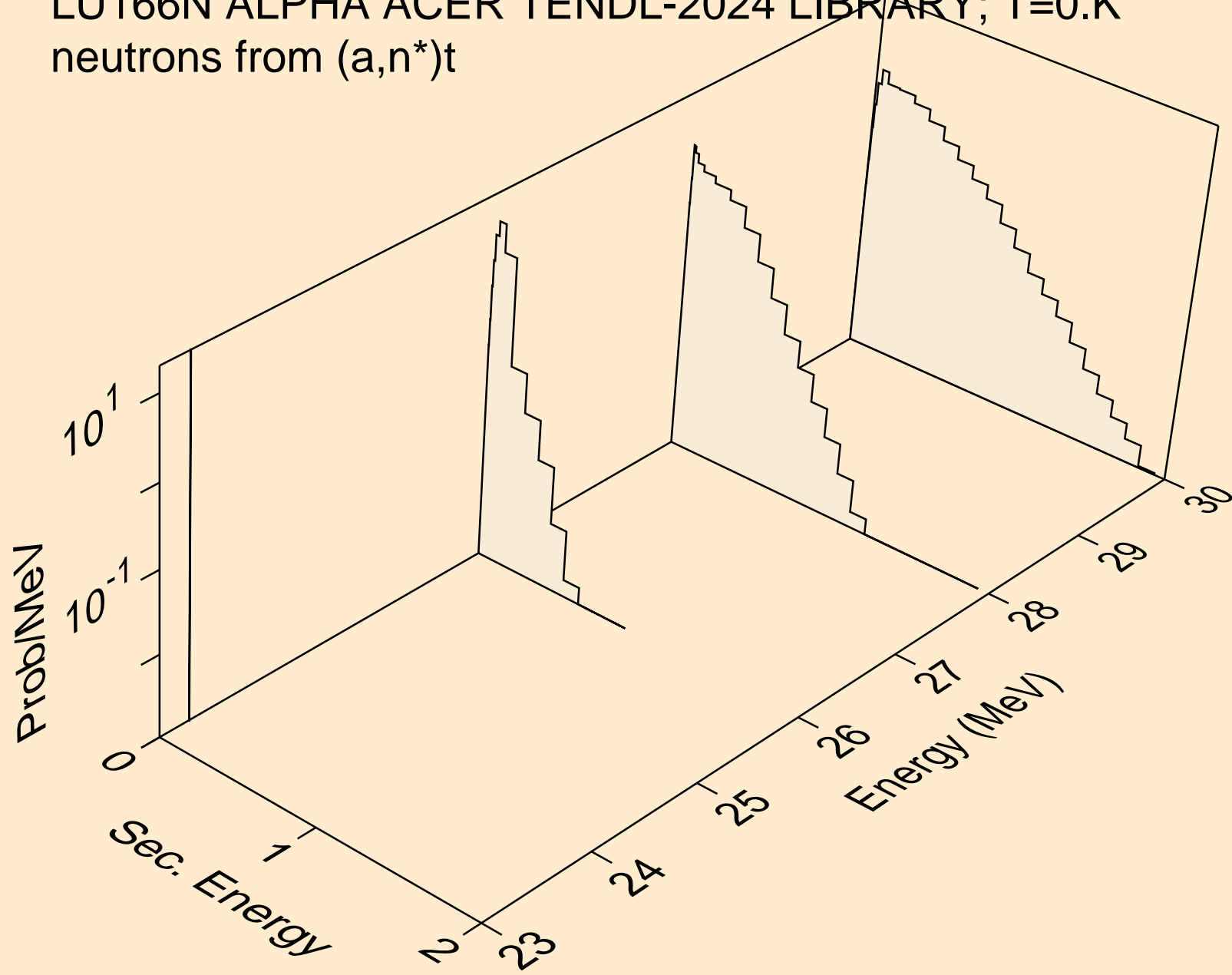

LU166N ALPHA ACER TENDL-2024 LIBRARY; T=0.K  
neutrons from (a,2np)

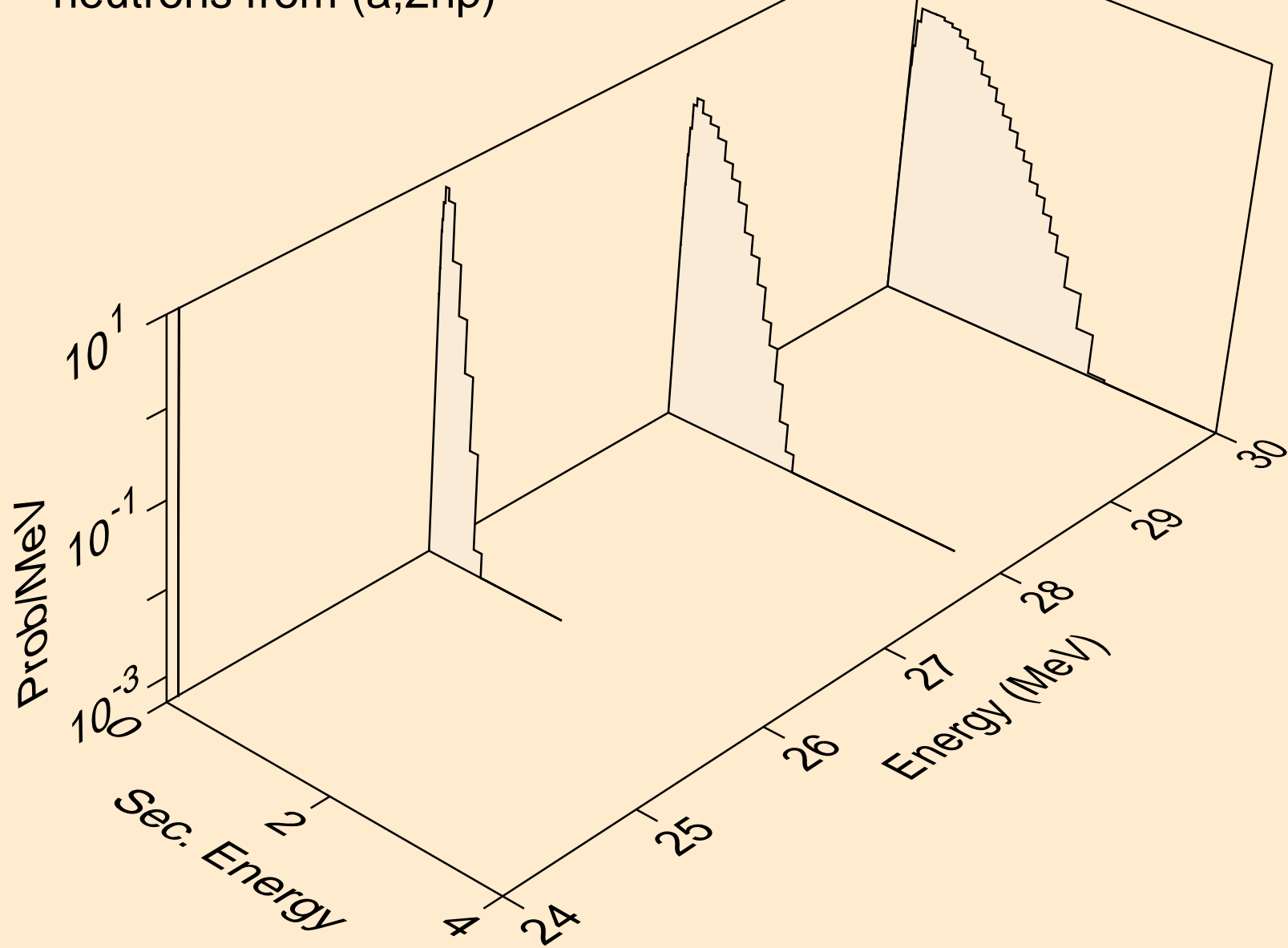

LU166N ALPHA ACER TENDL-2024 LIBRARY; T=0.K  
neutrons from (a,n2p)

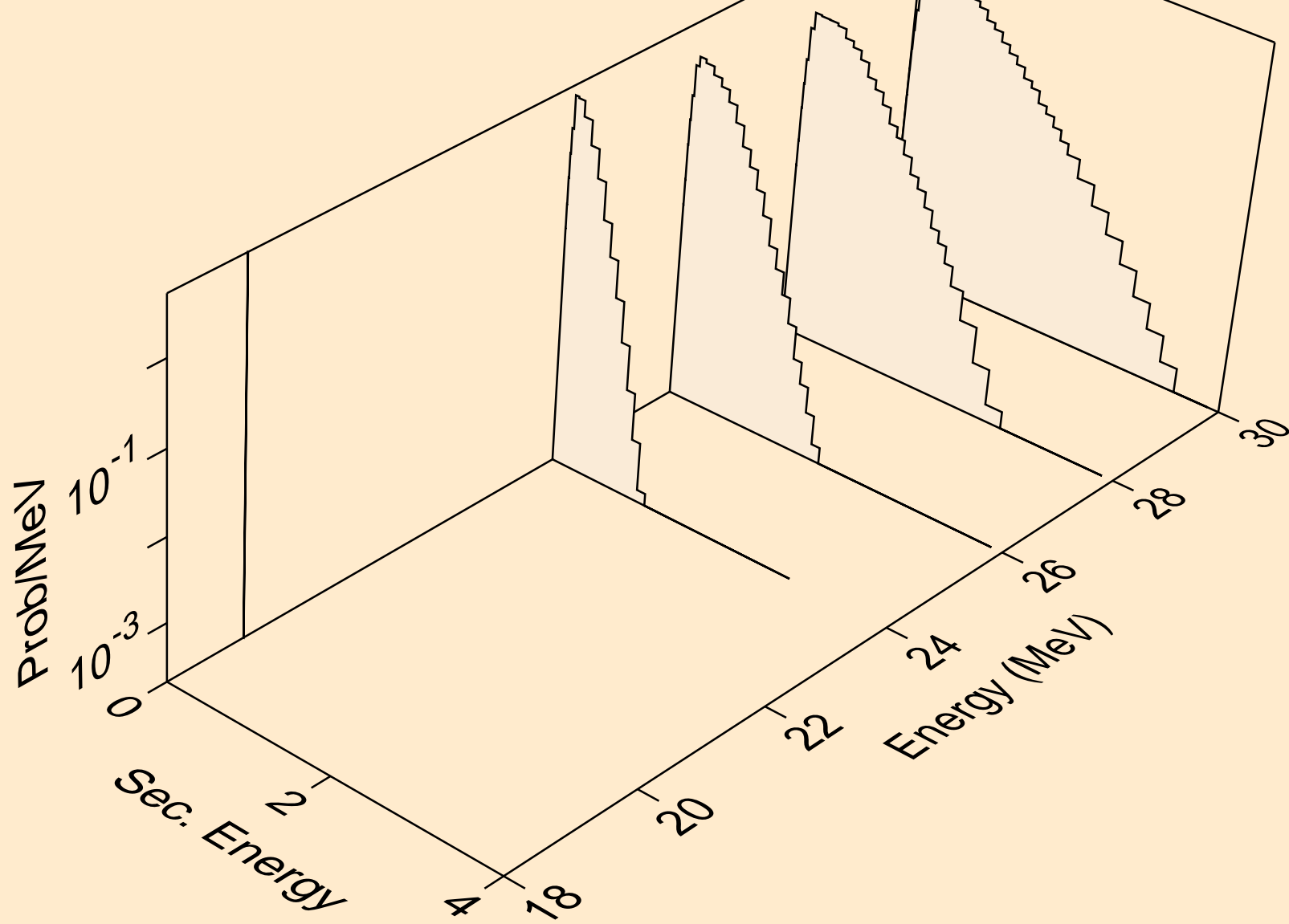

LU166N ALPHA ACER TENDL-2024 LIBRARY; T=0.K  
neutrons from (a,npa)

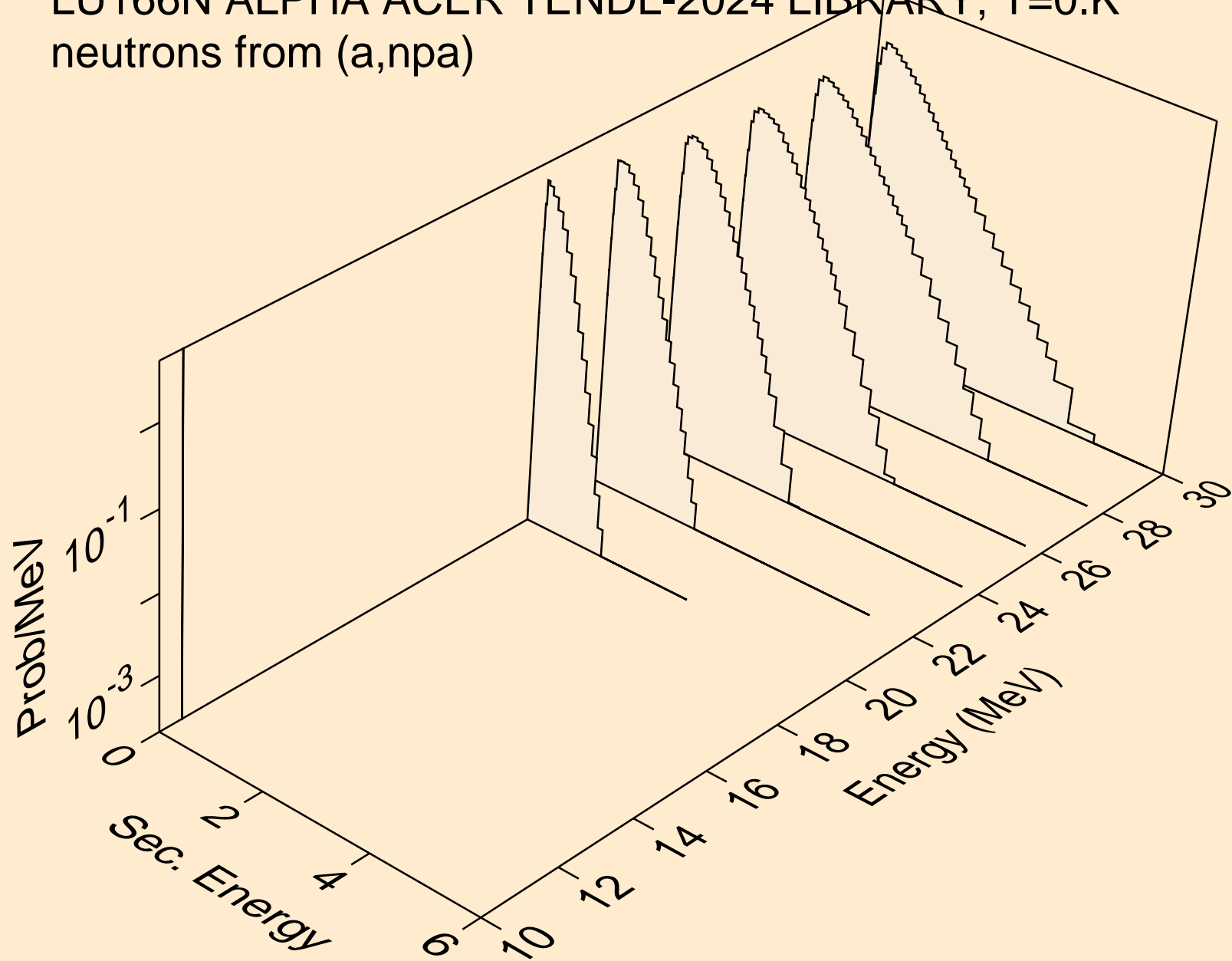

LU166N ALPHA ACER TENDL-2024 LIBRARY; T=0.K  
protons from (a,x)

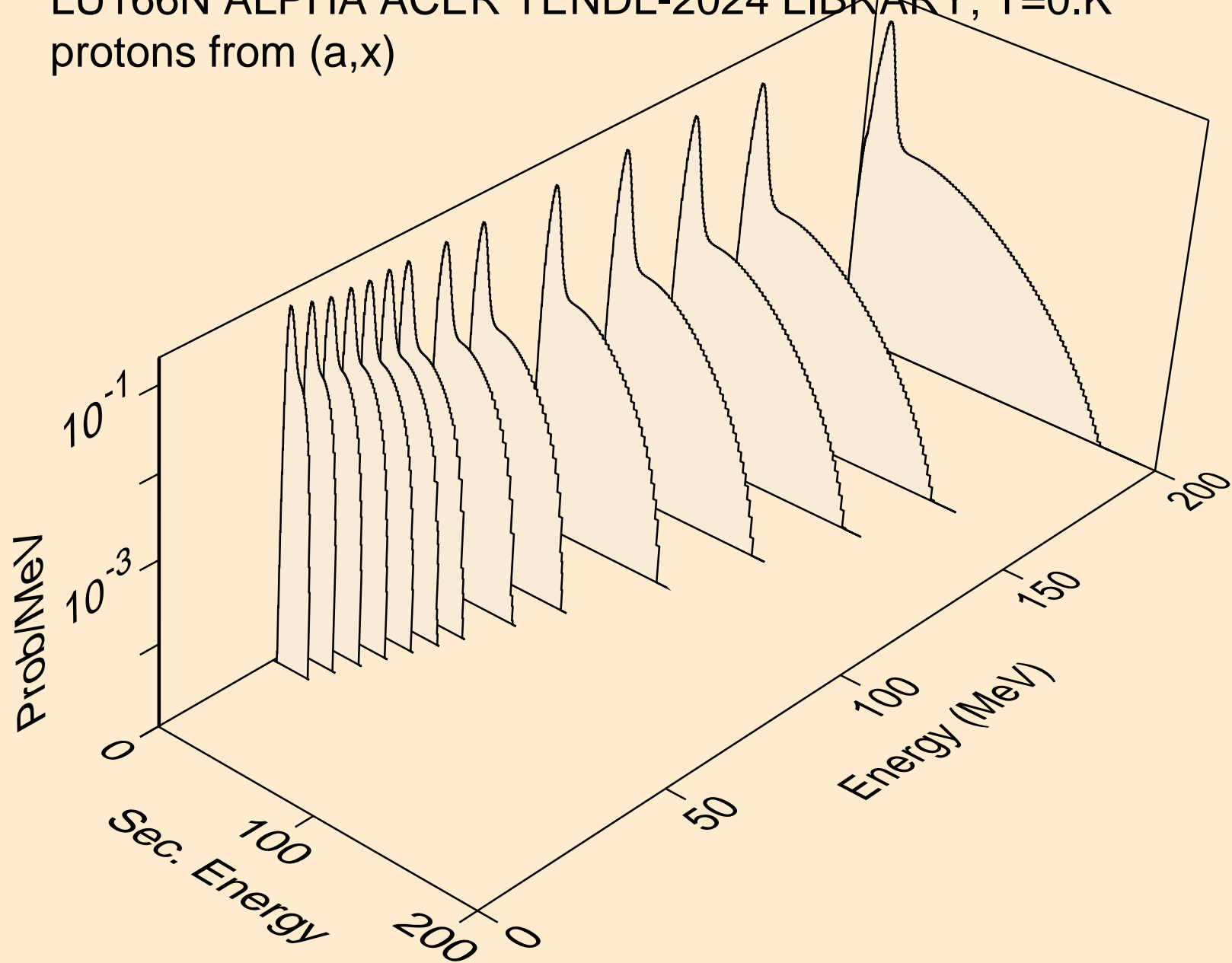

LU166N ALPHA ACER TENDL-2024 LIBRARY; T=0.K  
protons from (a,n\*)p

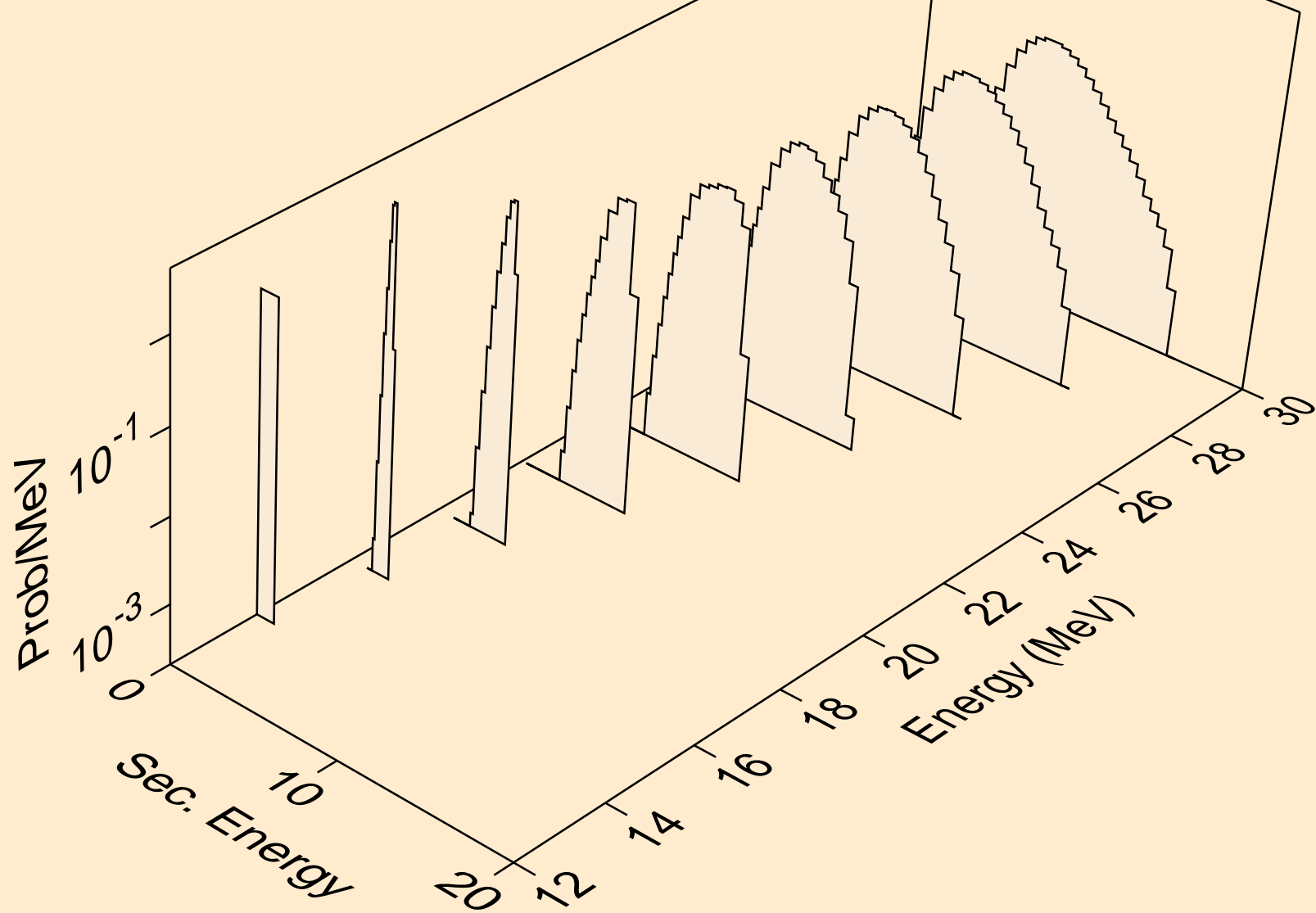

LU166N ALPHA ACER TENDL-2024 LIBRARY; T=0.K  
protons from (a,2np)

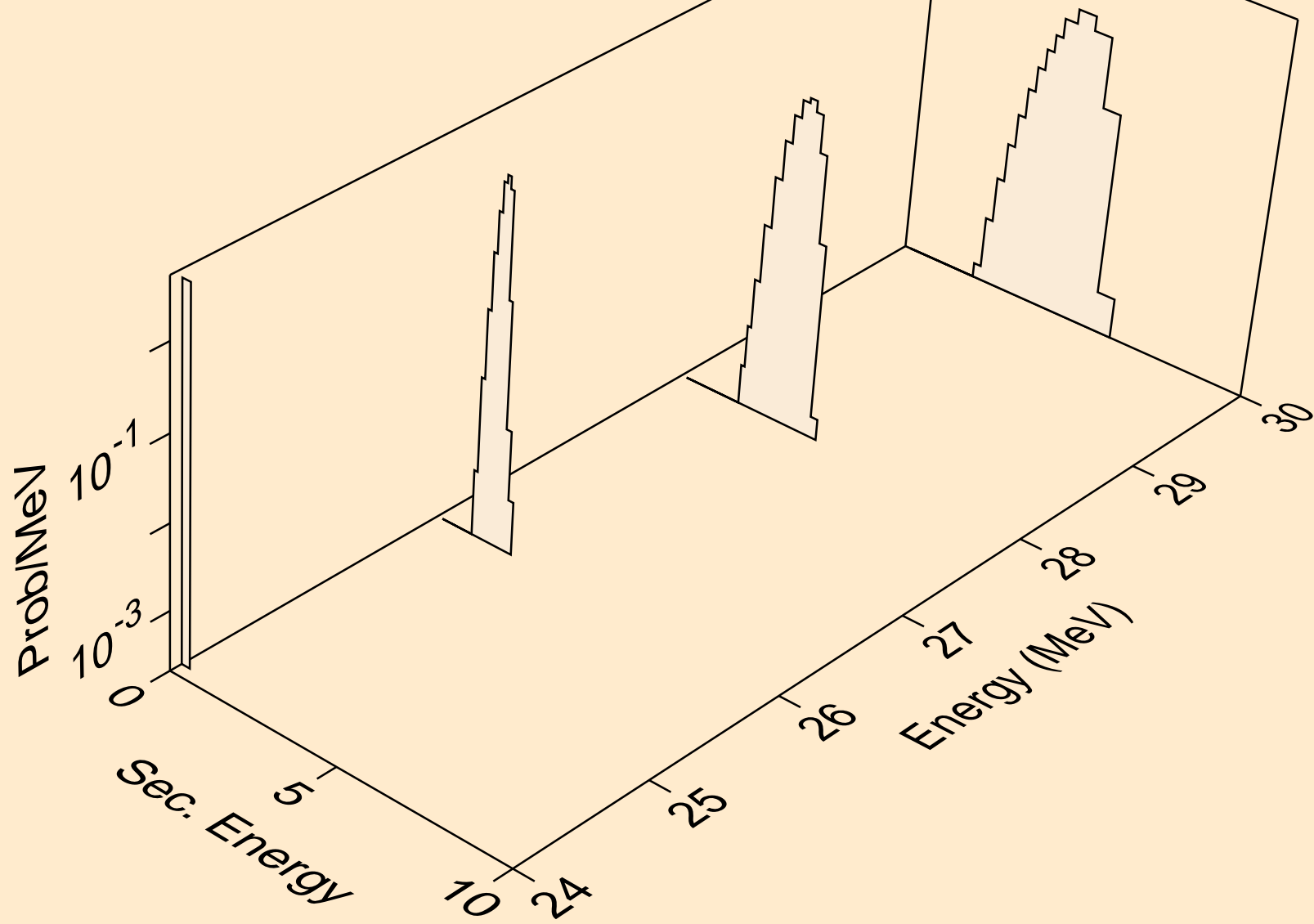

LU166N ALPHA ACER TENDL-2024 LIBRARY; T=0.K  
protons from (a,n2p)

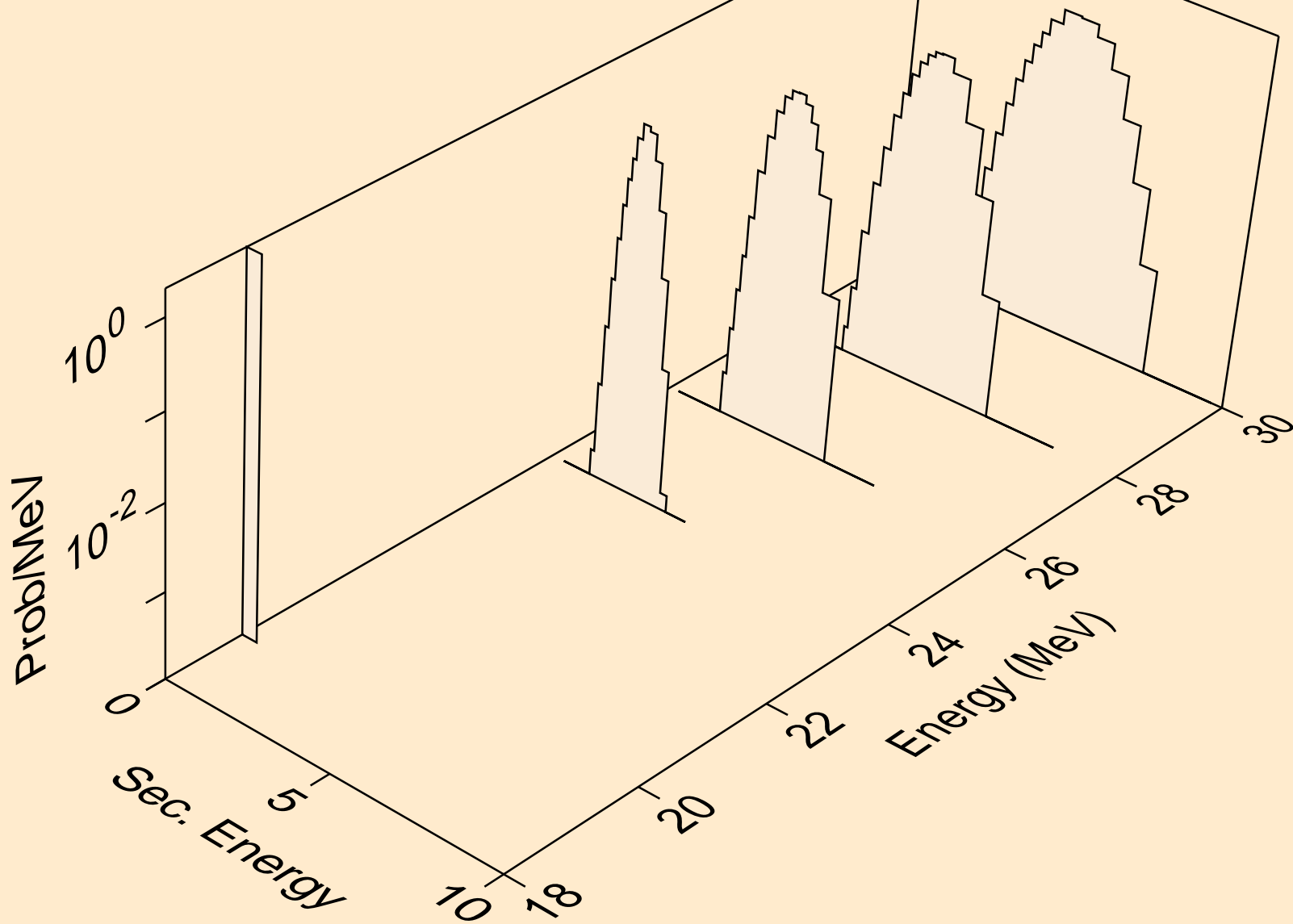

LU166N ALPHA ACER TENDL-2024 LIBRARY; T=0.K  
protons from (a,npa)

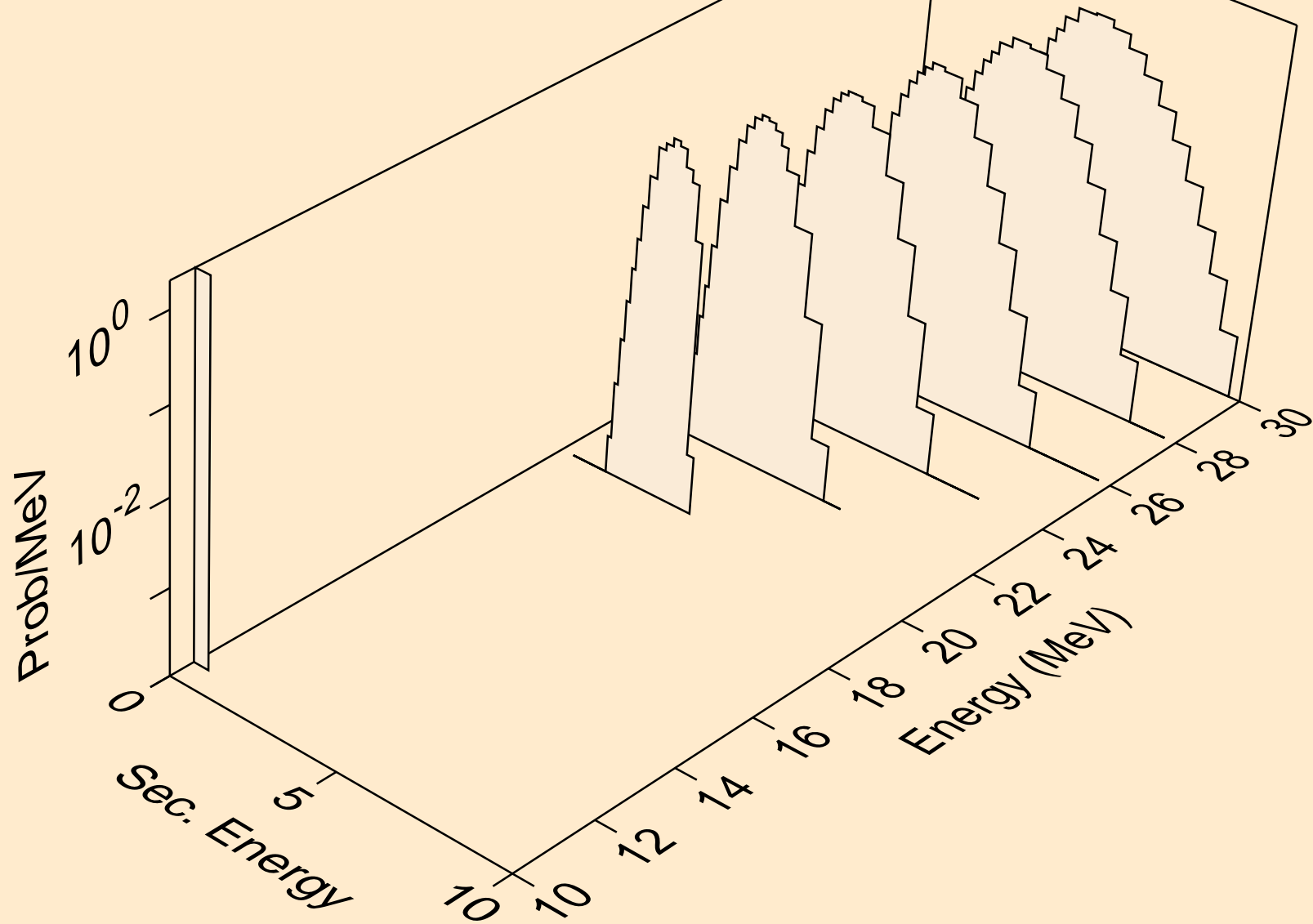

LU166N ALPHA ACER TENDL-2024 LIBRARY; T=0.K  
protons from (a,p)

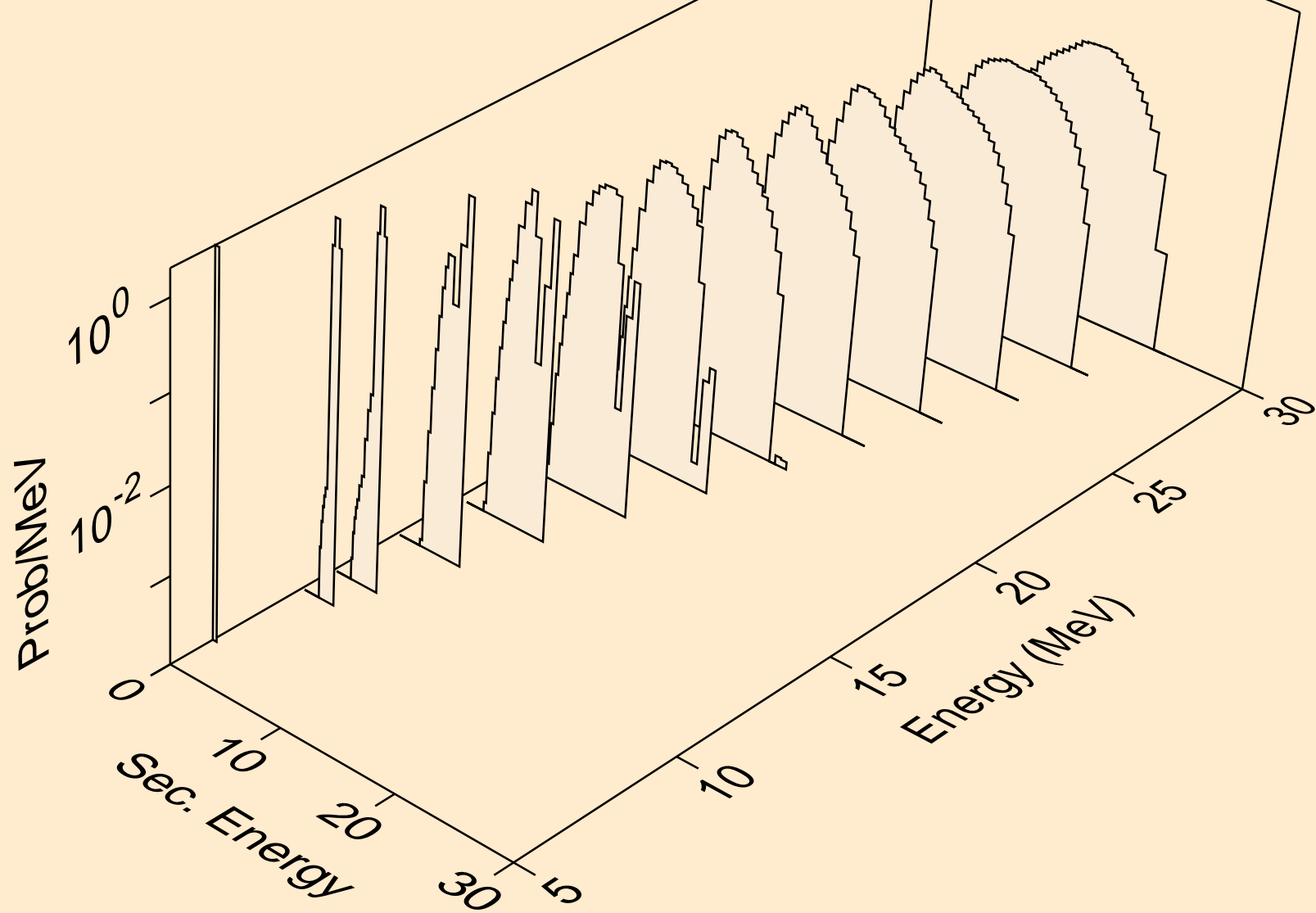

LU166N ALPHA ACER TENDL-2024 LIBRARY; T=0.K  
protons from (a,2p)

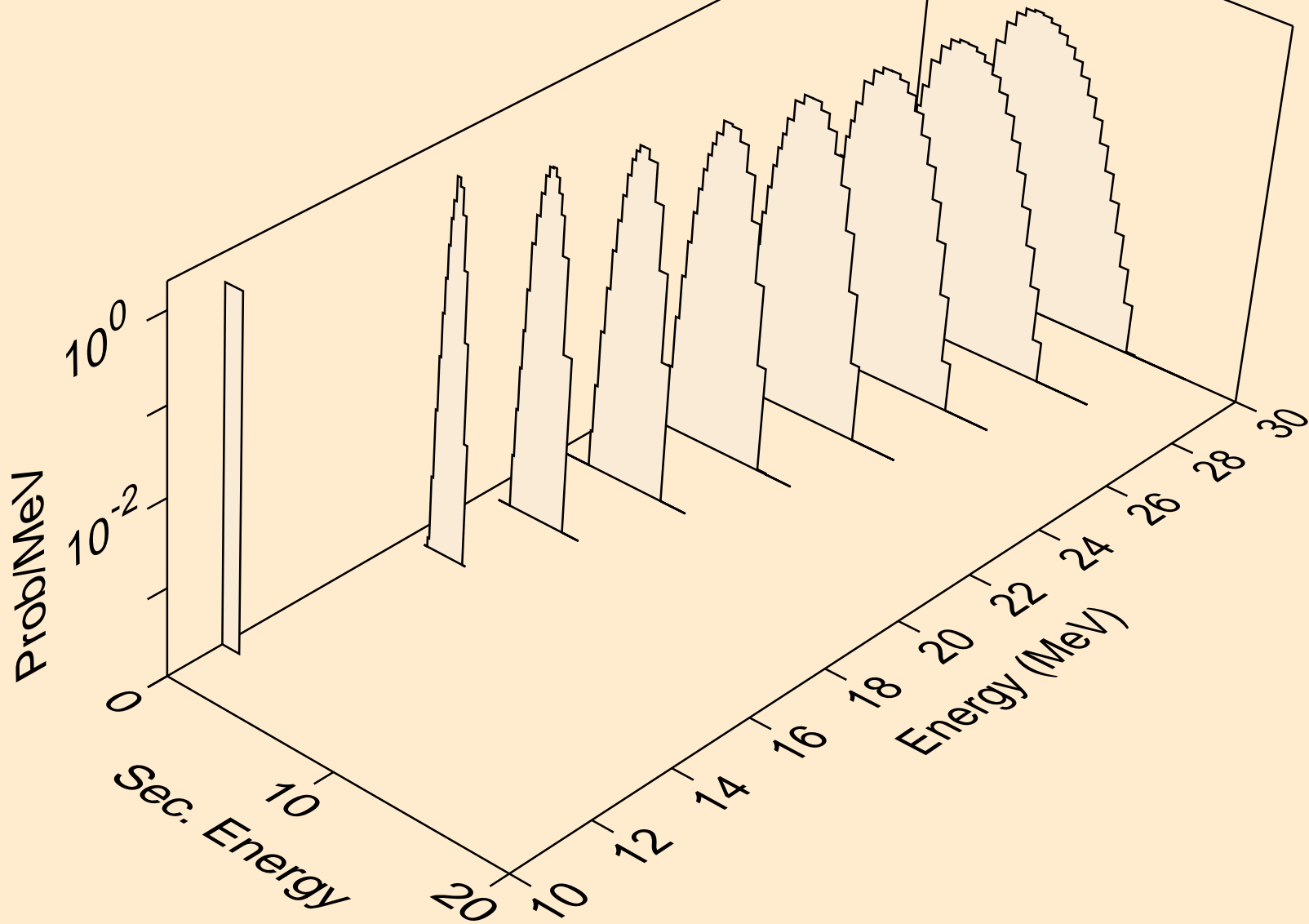

LU166N ALPHA ACER TENDL-2024 LIBRARY; T=0.K  
protons from (a,pa)

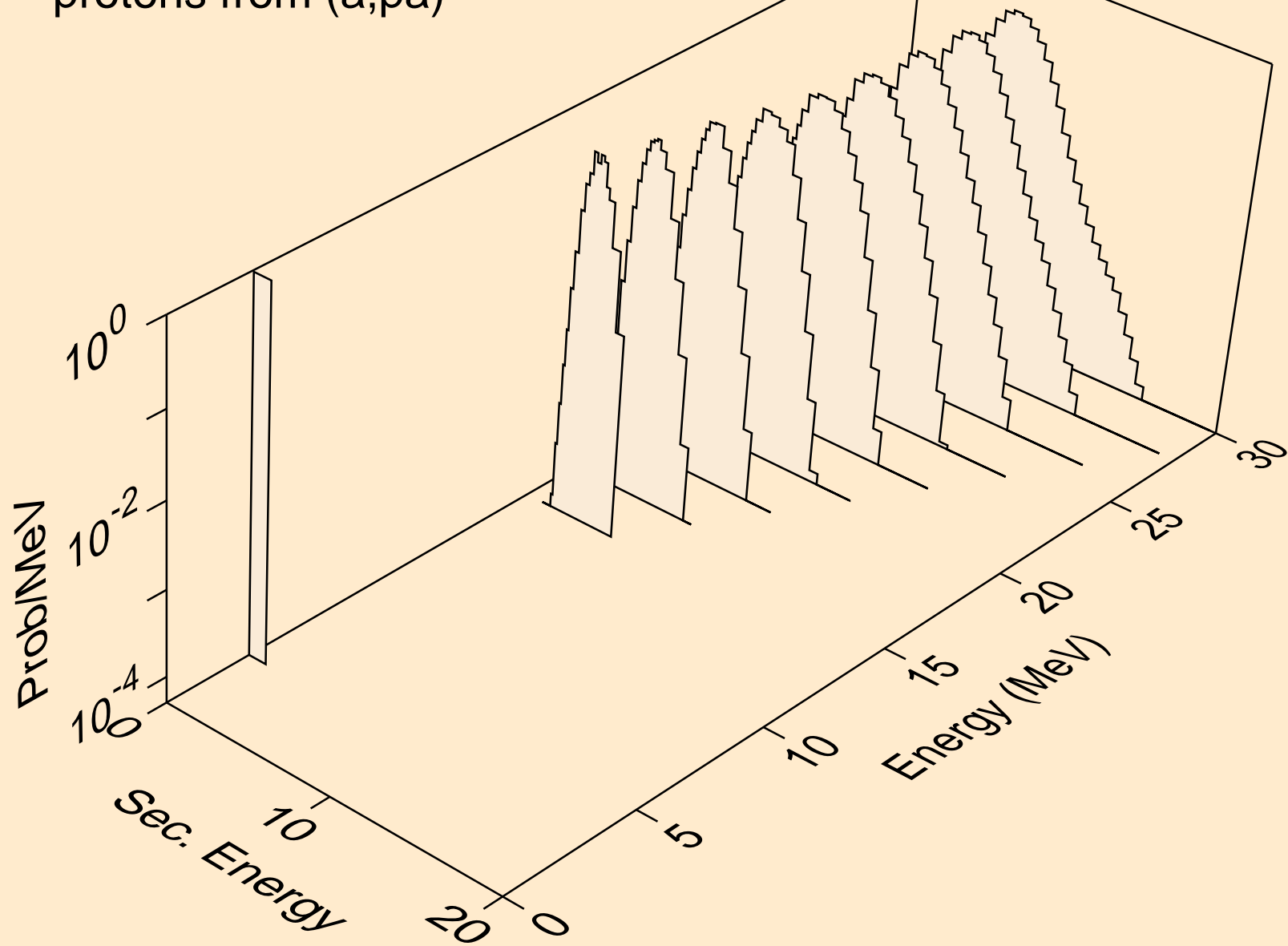

LU166N ALPHA ACER TENDL-2024 LIBRARY; T=0.K  
protons from (a,pd)

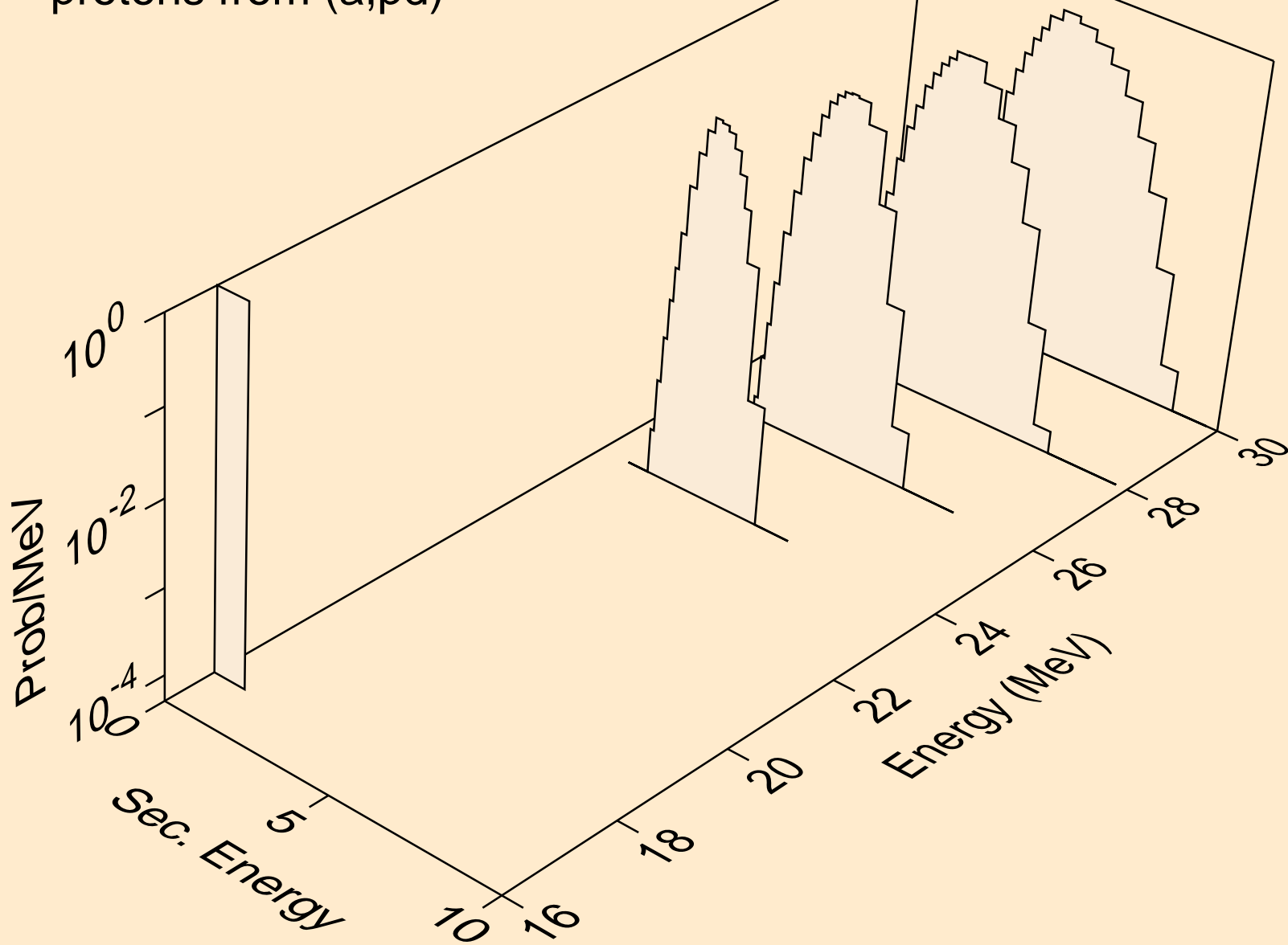

LU166N ALPHA ACER TENDL-2024 LIBRARY; T=0.K  
deuterons from (a,x)

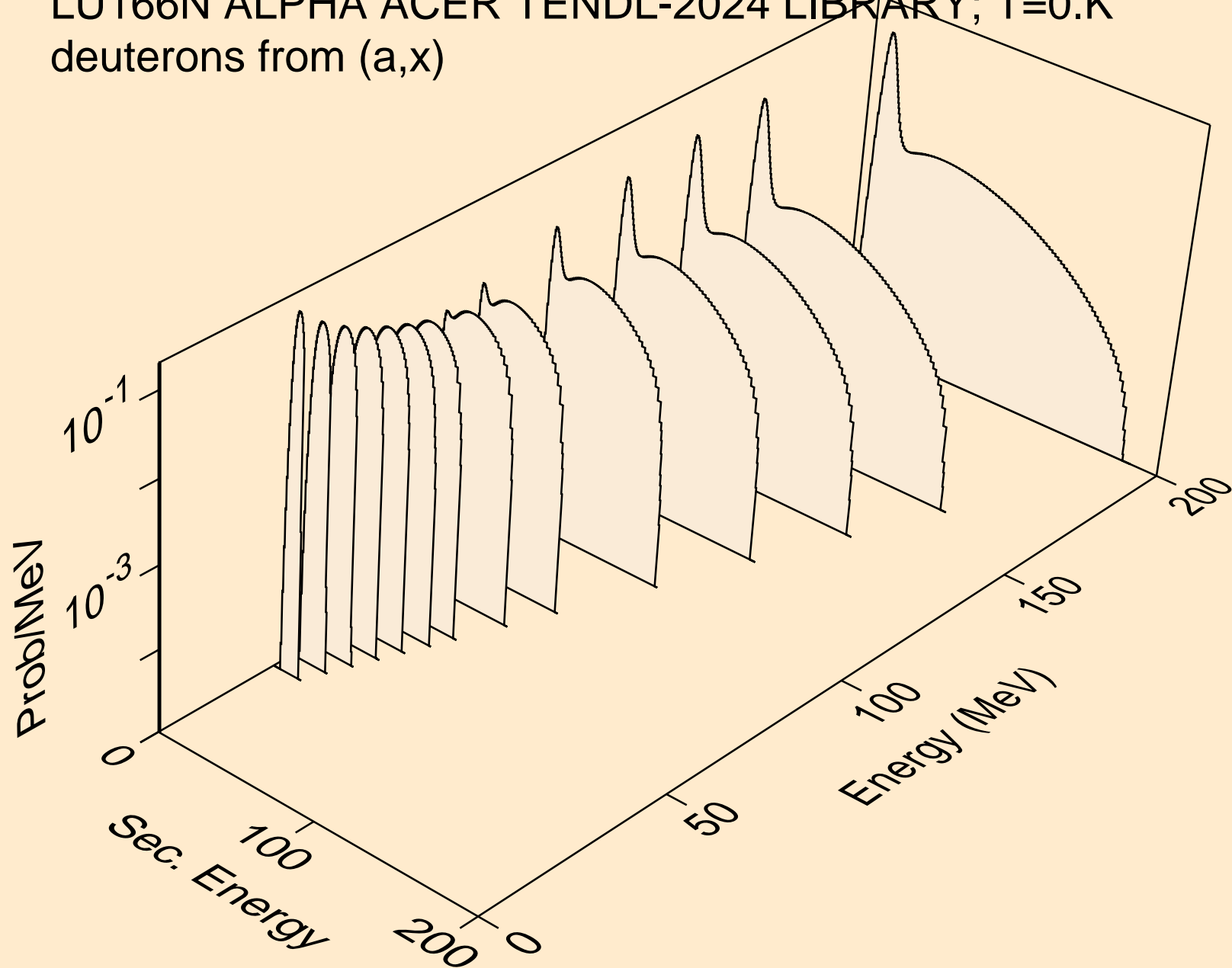

LU166N ALPHA ACER TENDL-2024 LIBRARY; T=0.K  
deuterons from (a,n\*)d

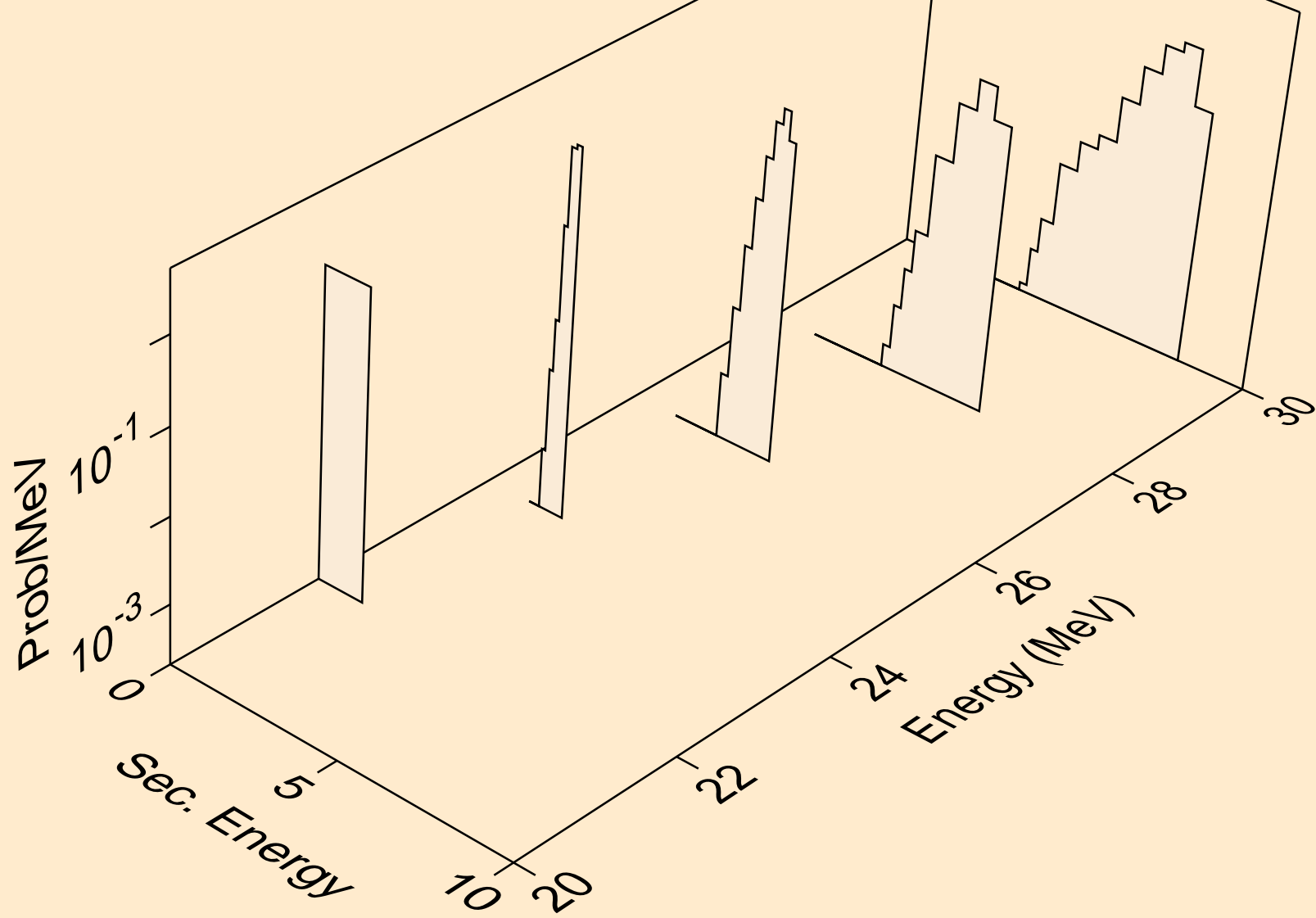

LU166N ALPHA ACER TENDL-2024 LIBRARY; T=0.K  
deuterons from (a,d)

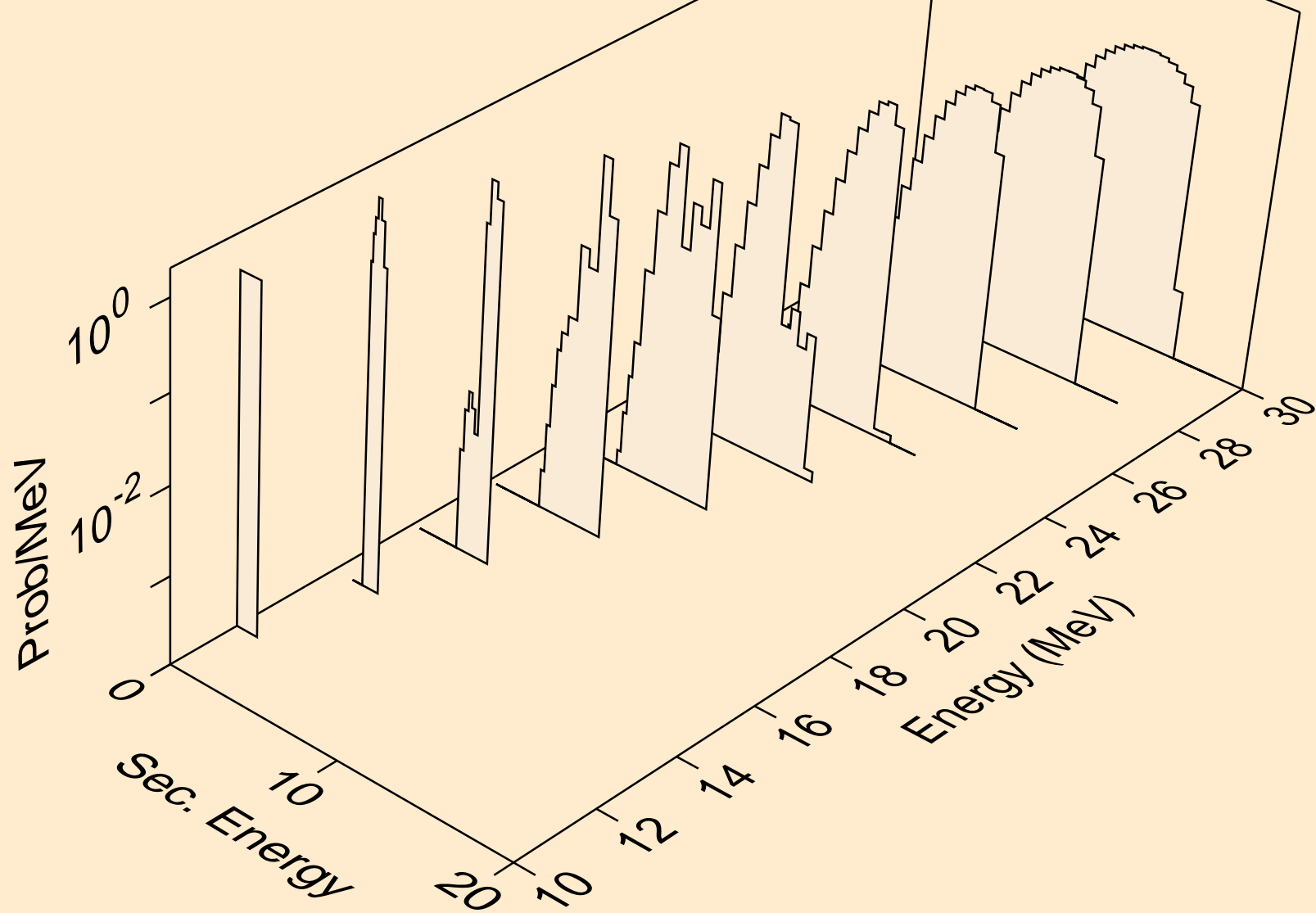

LU166N ALPHA ACER TENDL-2024 LIBRARY; T=0.K  
deuterons from (a,pd)

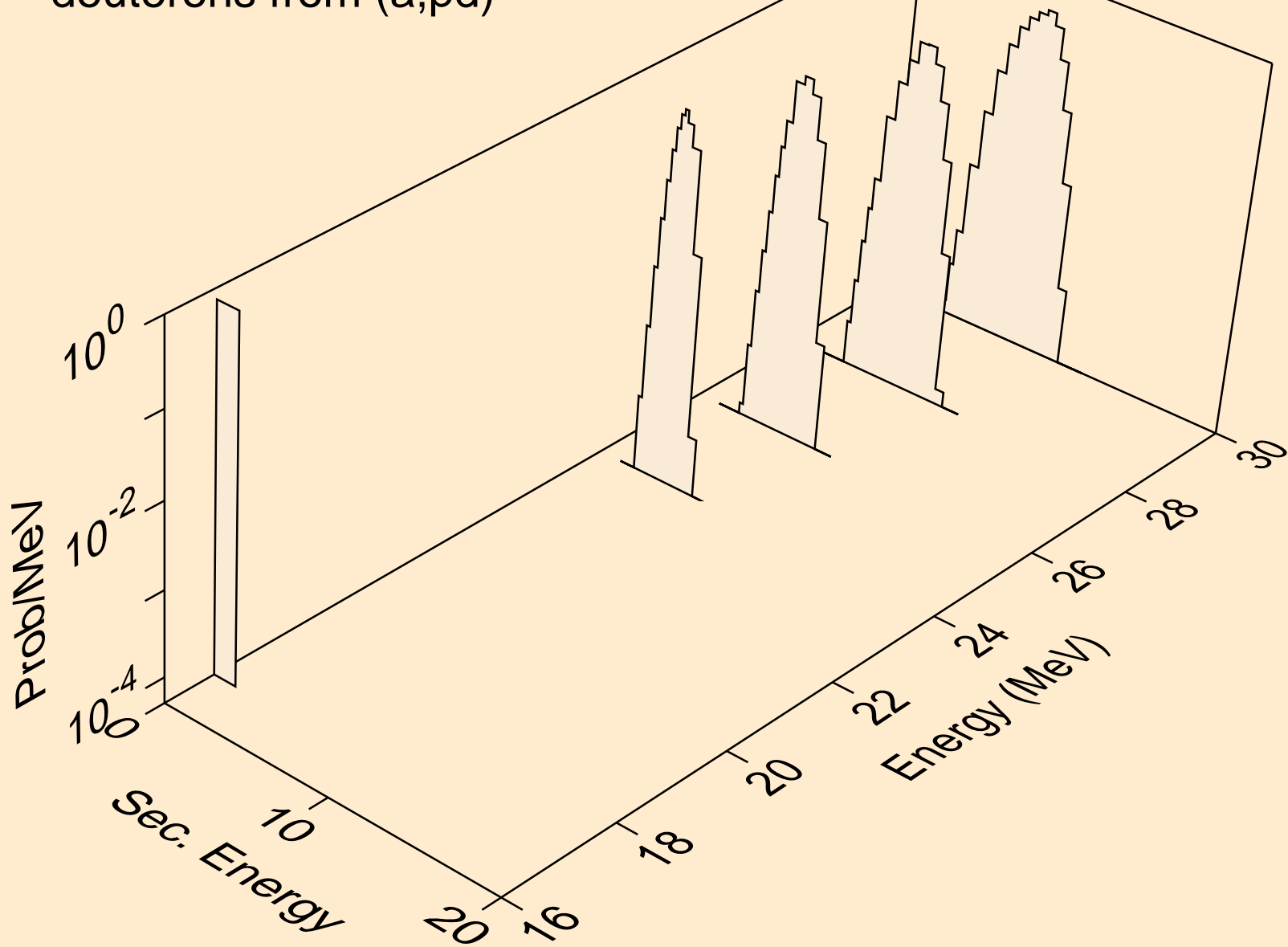

LU166N ALPHA ACER TENDL-2024 LIBRARY; T=0.K  
deuterons from (a,da)

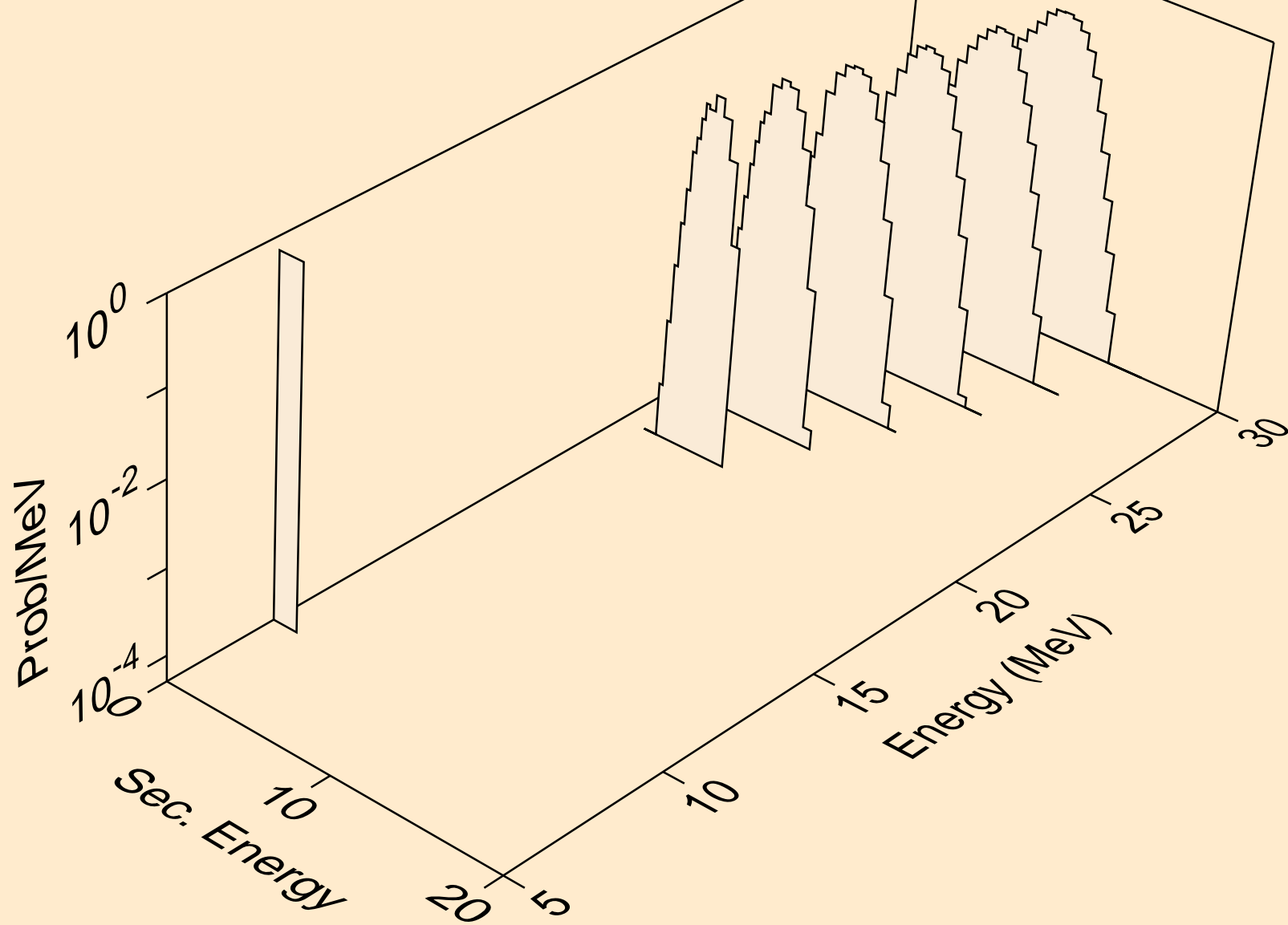

LU166N ALPHA ACER TENDL-2024 LIBRARY; T=0.K  
tritons from (a,x)

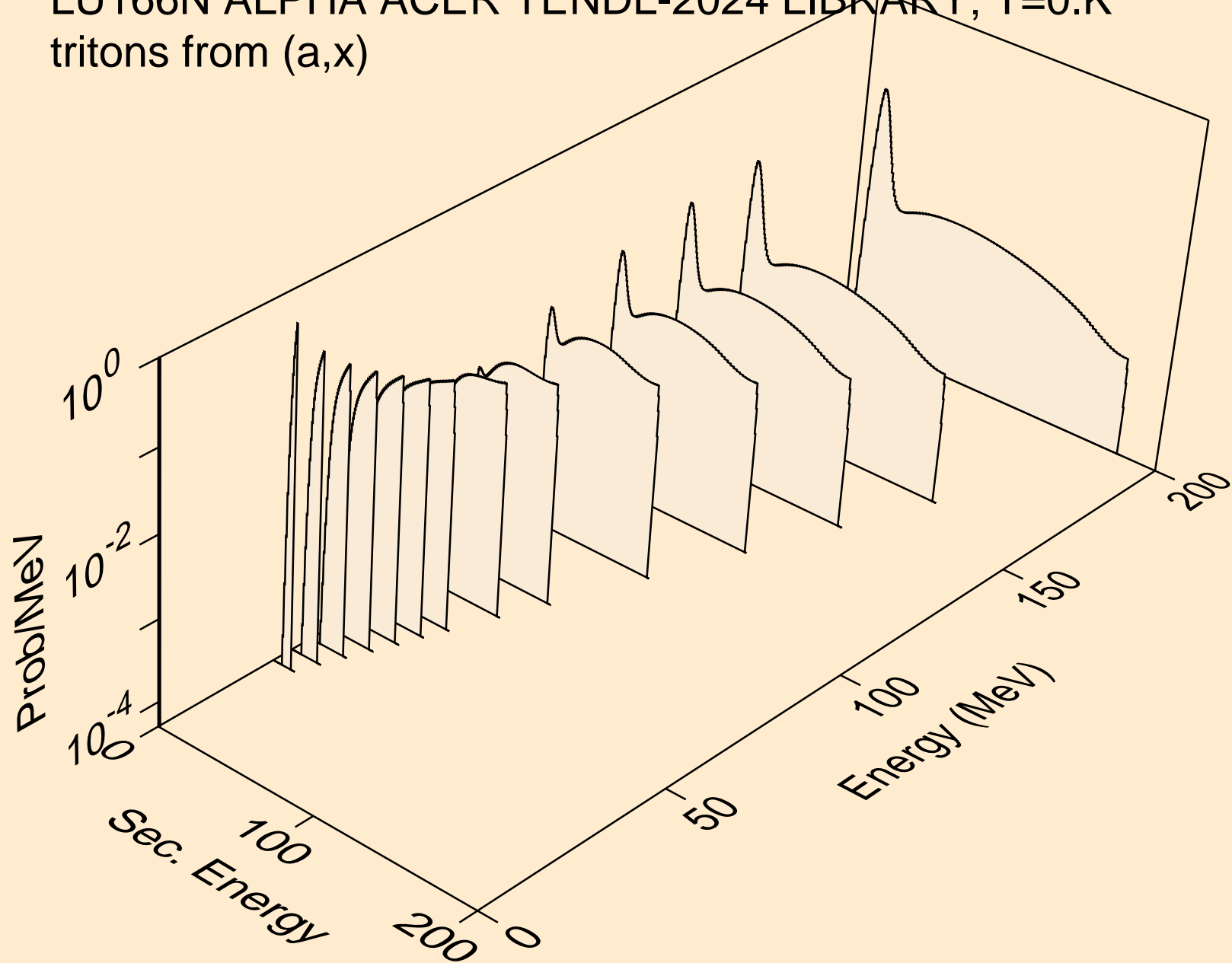

LU166N ALPHA ACER TENDL-2024 LIBRARY; T=0.K  
tritons from (a,n\*)t

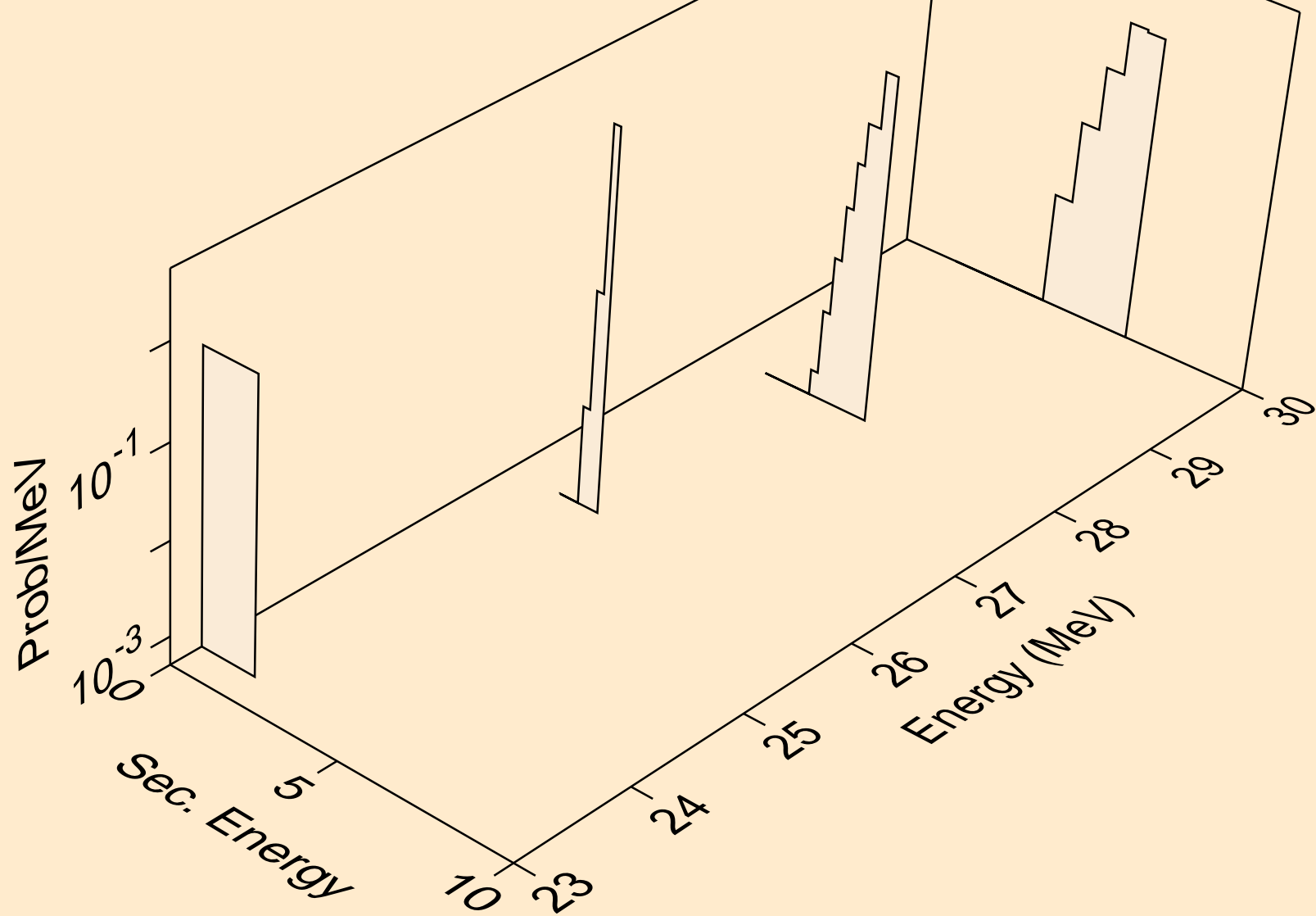

LU166N ALPHA ACER TENDL-2024 LIBRARY; T=0.K  
tritons from (a,t)

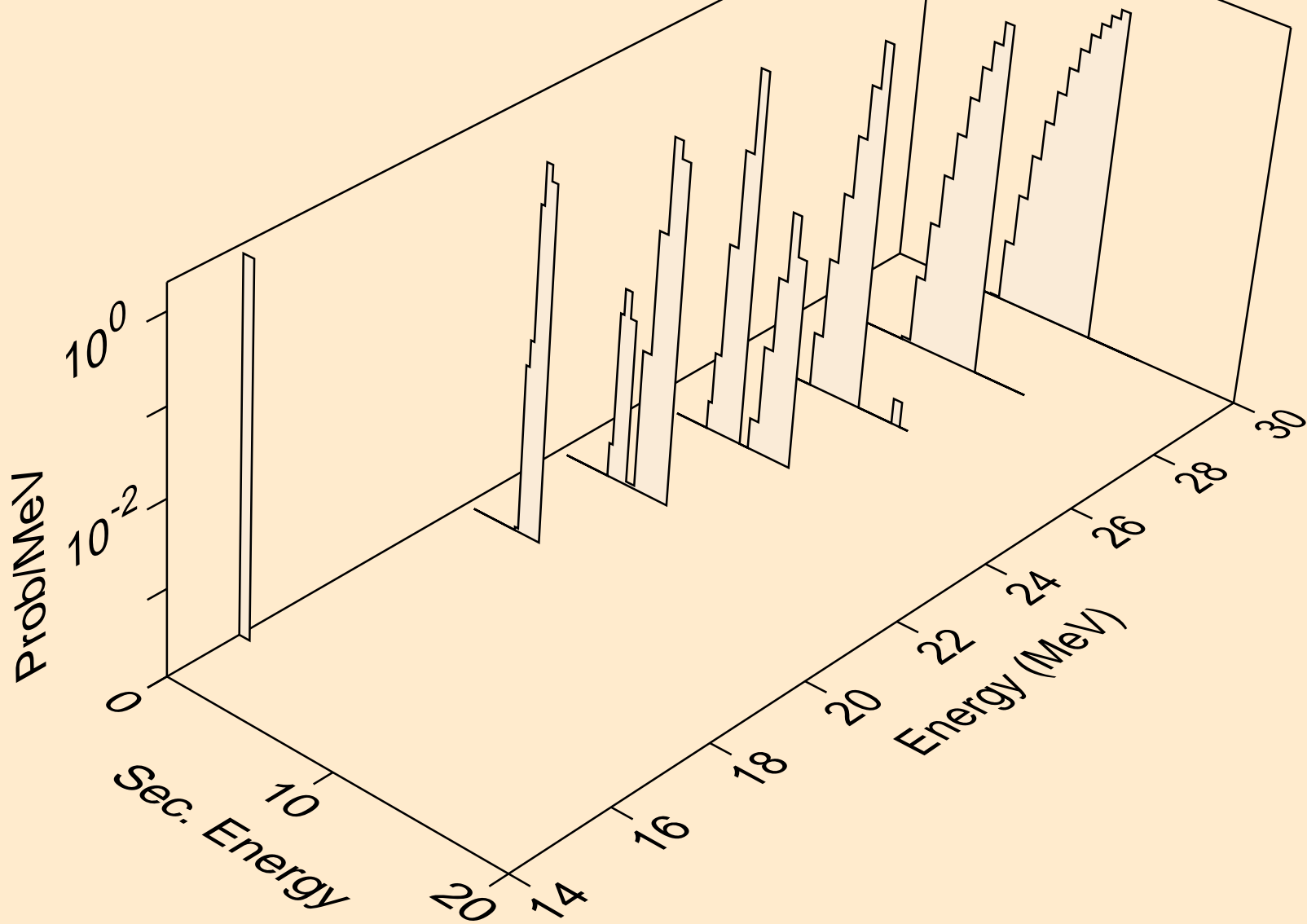

LU166N ALPHA ACER TENDL-2024 LIBRARY; T=0.K  
he3s from (a,x)

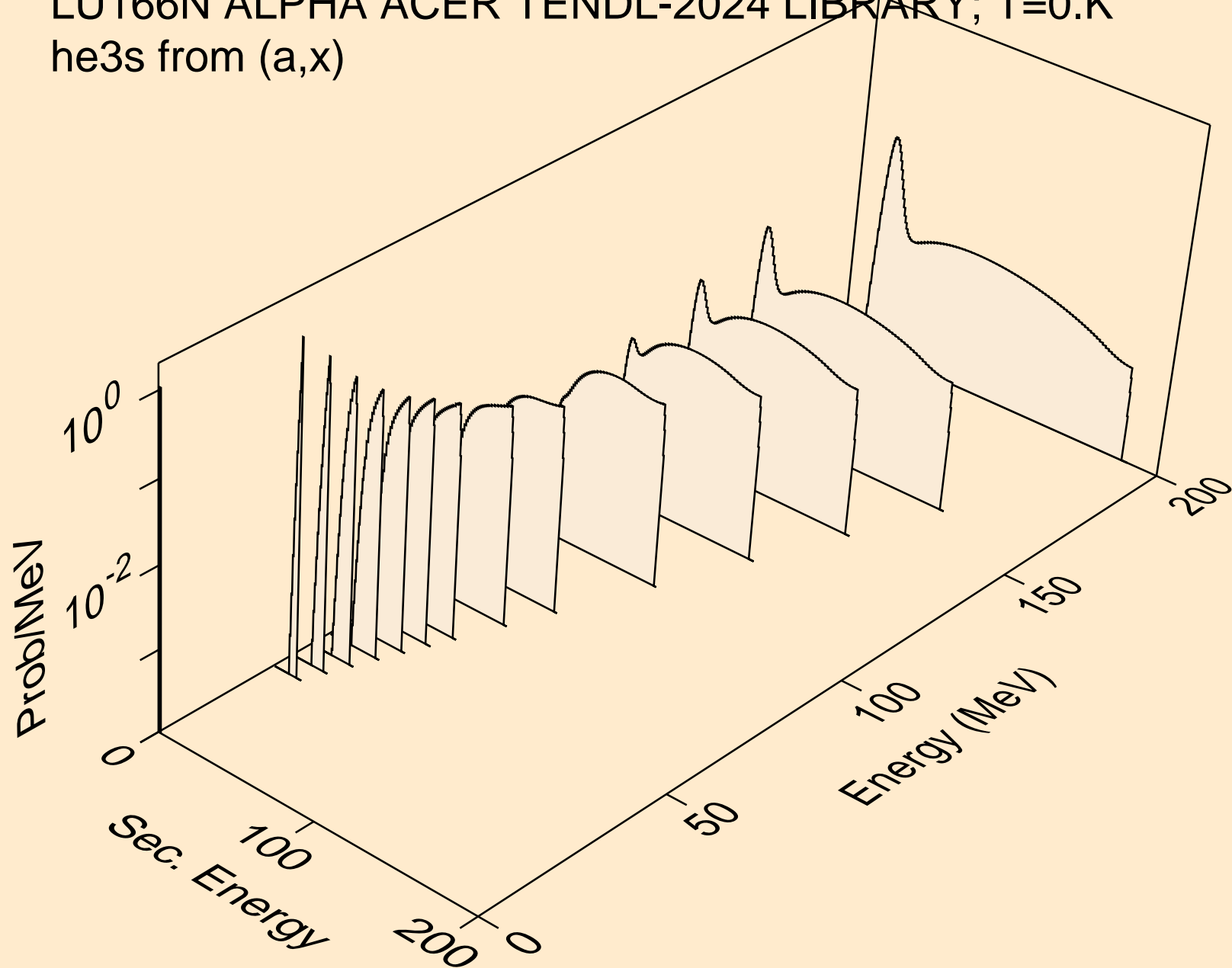

LU166N ALPHA ACER TENDL-2024 LIBRARY; T=0.K  
he3s from (a,he3)

