

O021 ALPHA ACER TENDL-2024 LIBRARY; T=0.K
Principal cross sections

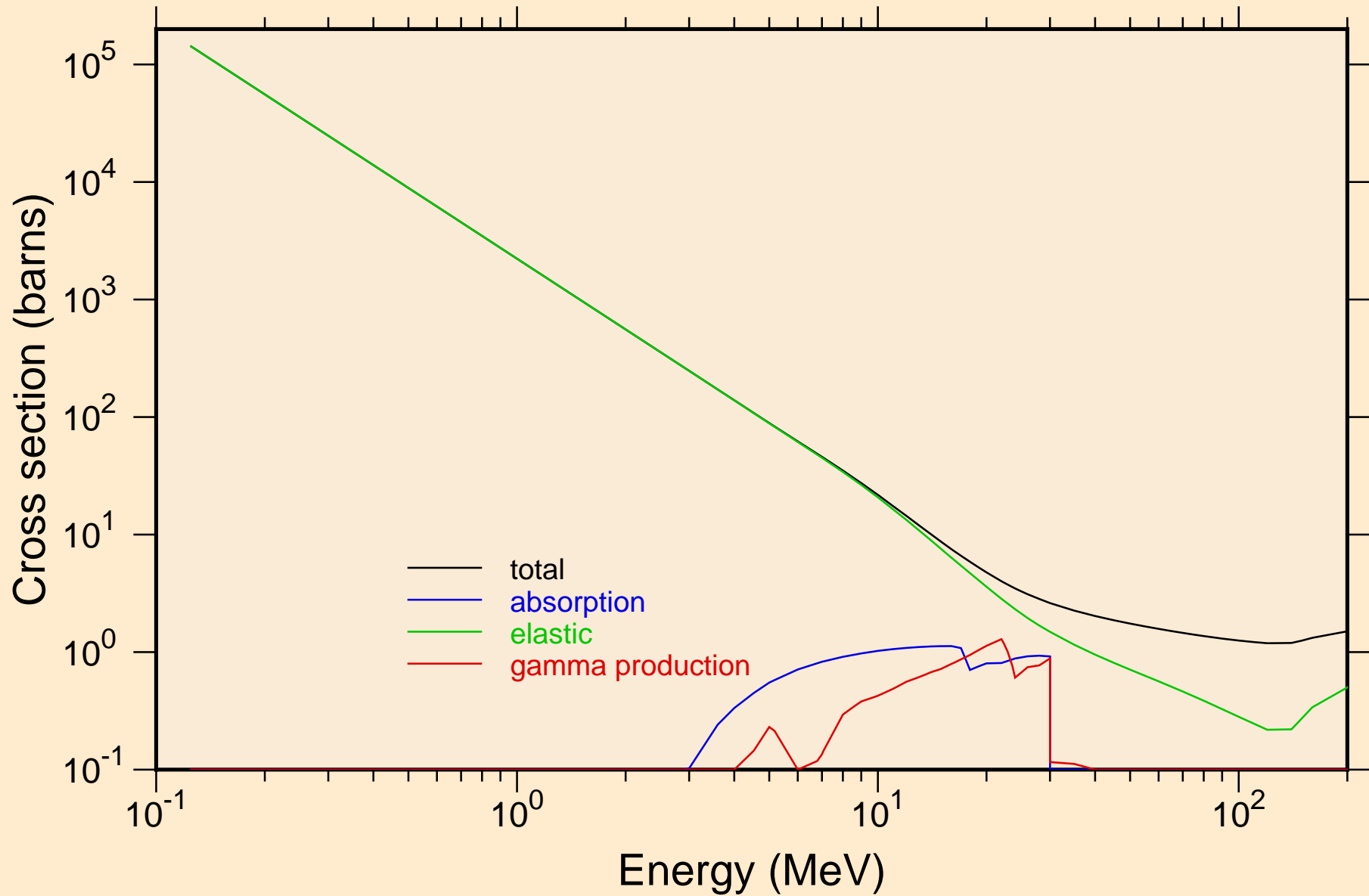

O021 ALPHA ACER TENDL-2024 LIBRARY; T=0.K
Heating

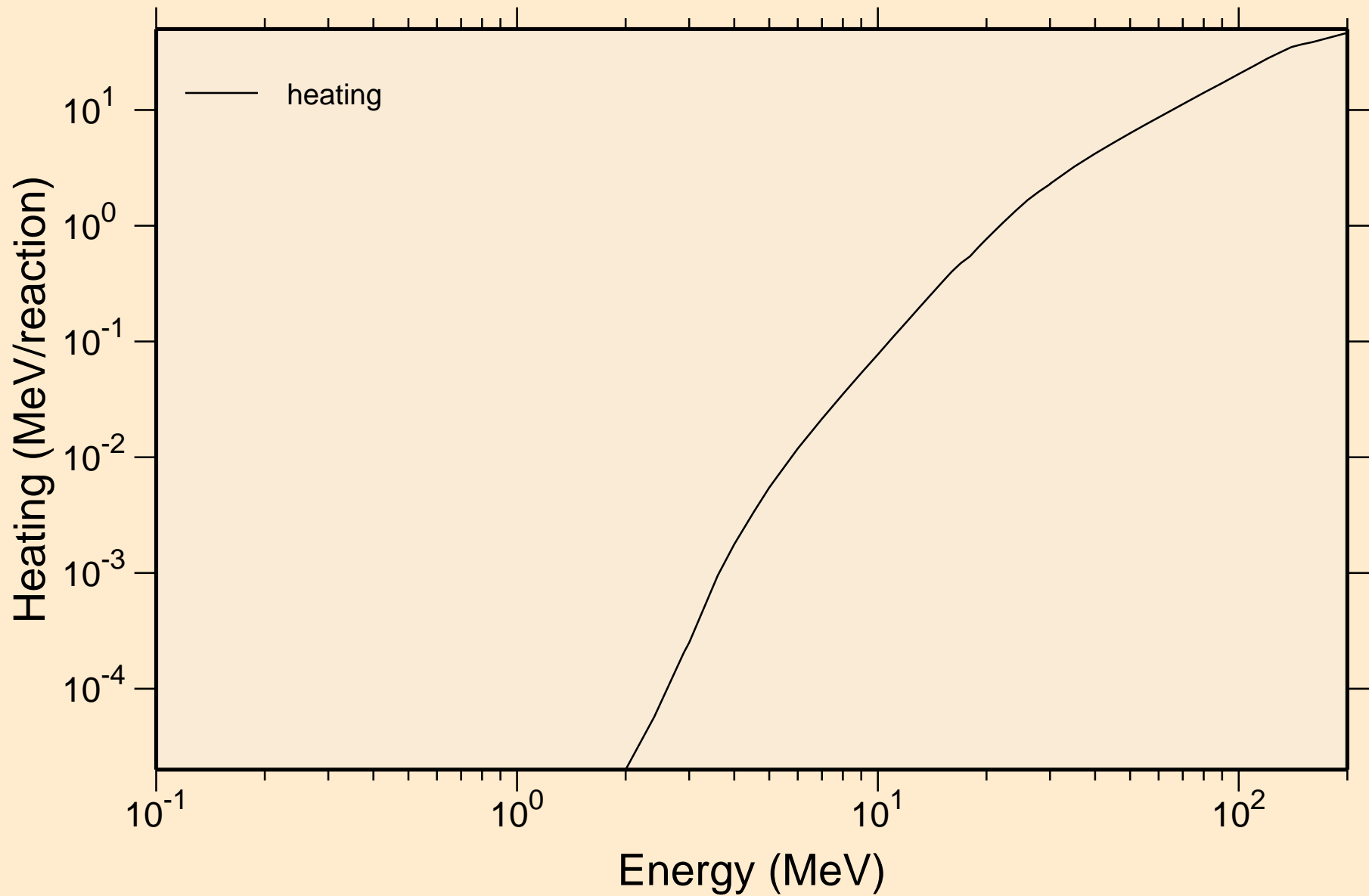

O021 ALPHA ACER TENDL-2024 LIBRARY; T=0.K

Principal cross sections

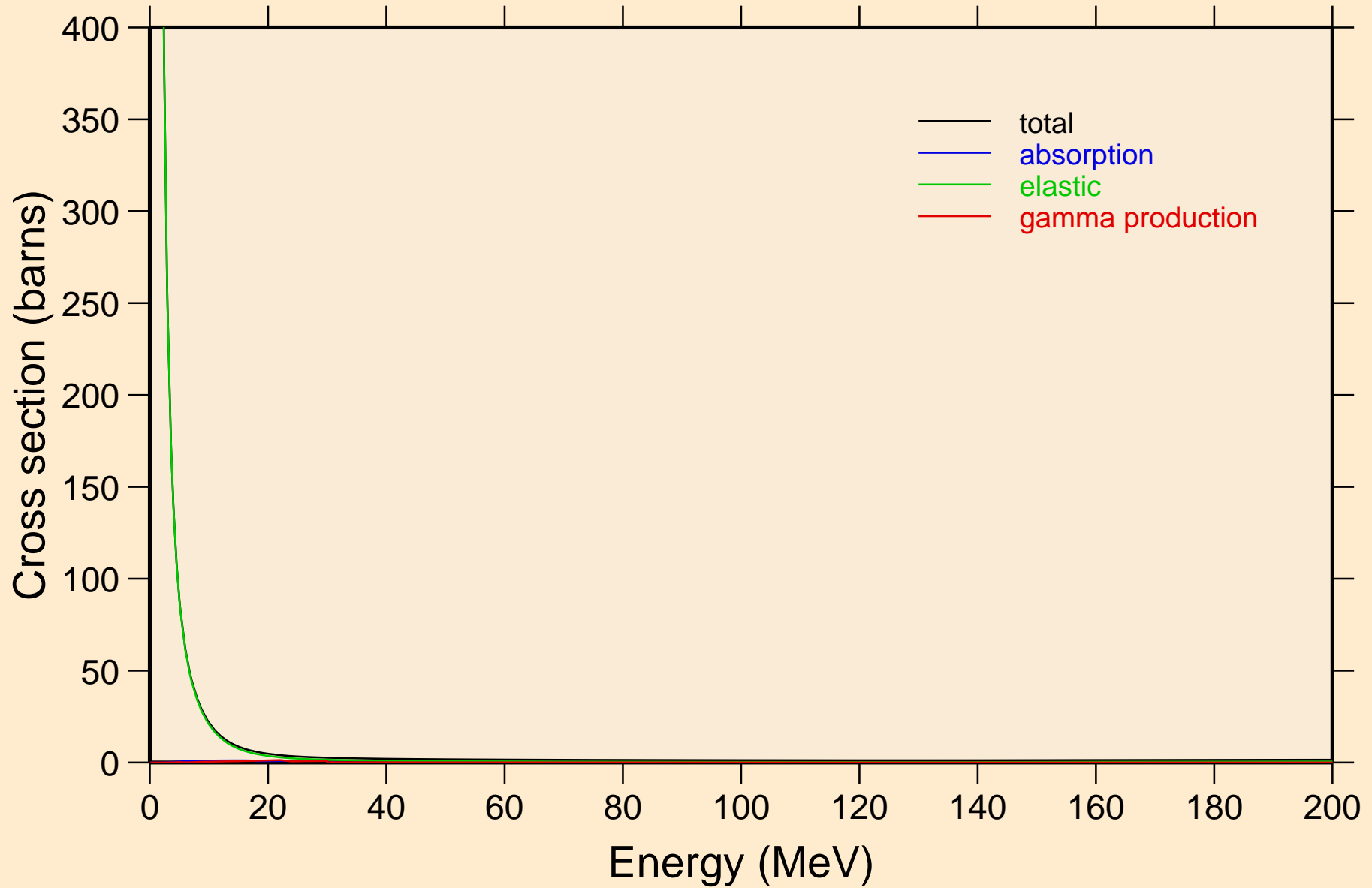

O021 ALPHA ACER TENDL-2024 LIBRARY; T=0.K

Heating

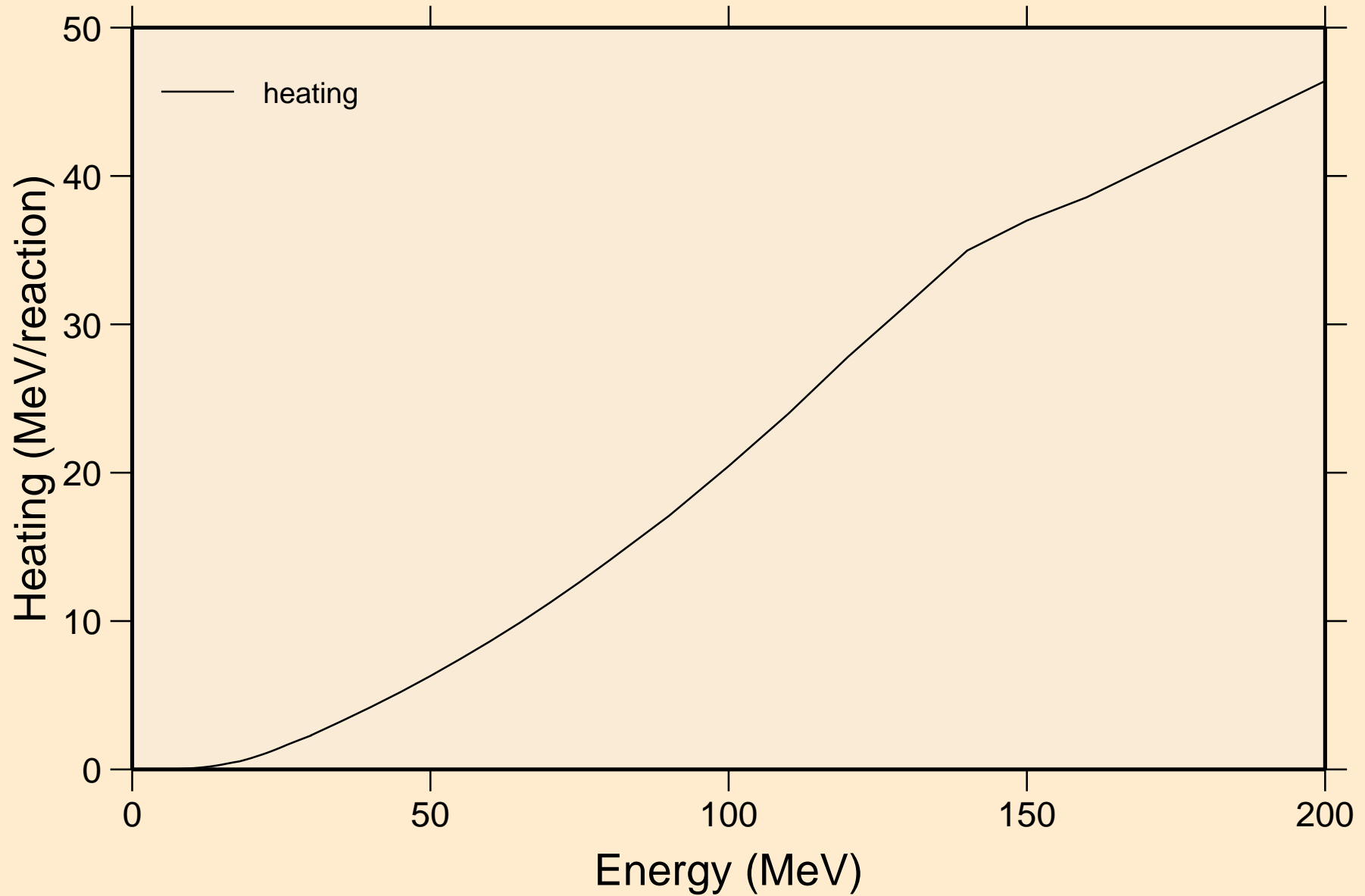

O021 ALPHA ACER TENDL-2024 LIBRARY; T=0.K

Threshold reactions

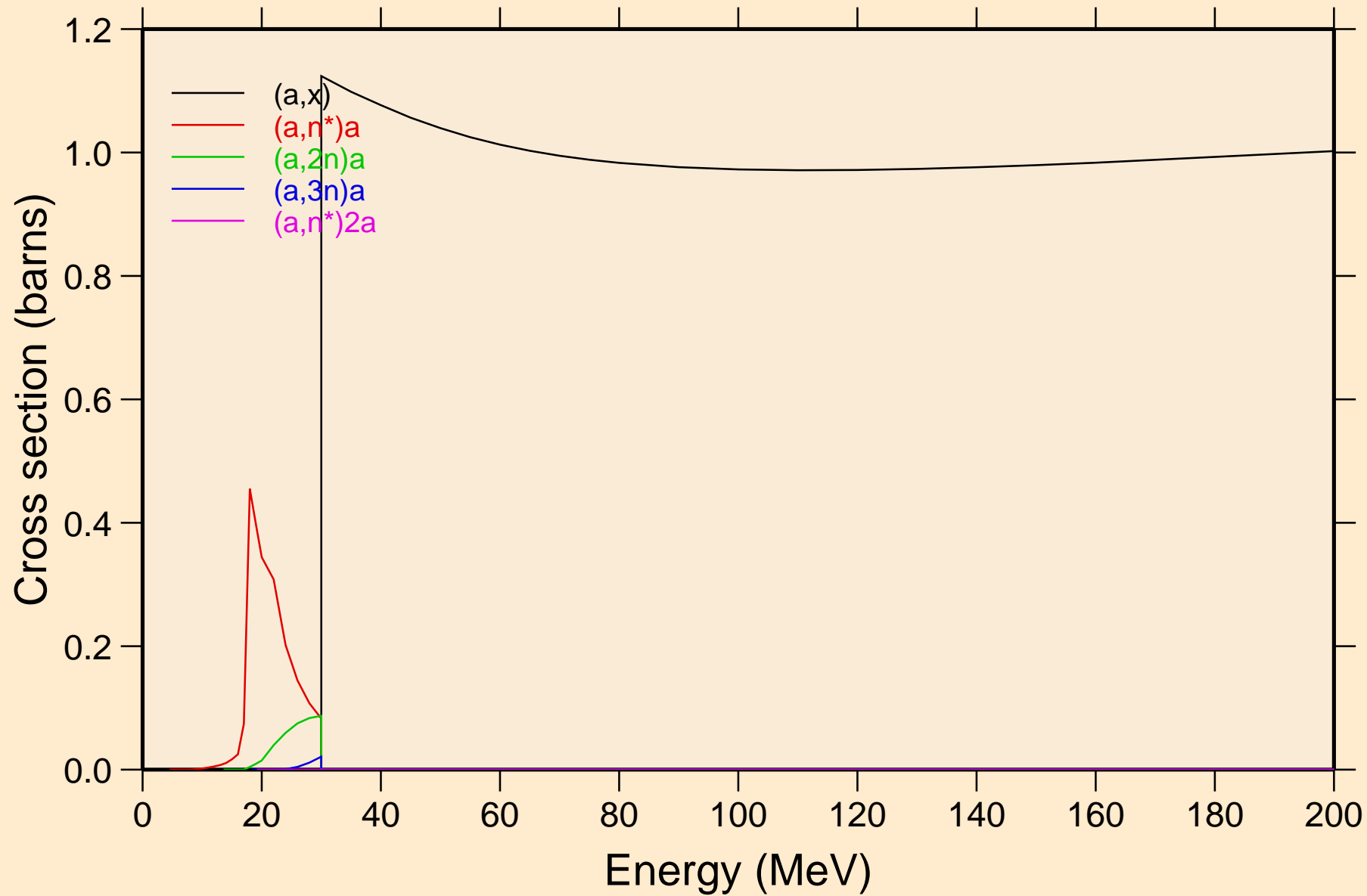

O021 ALPHA ACER TENDL-2024 LIBRARY; T=0.K
Threshold reactions

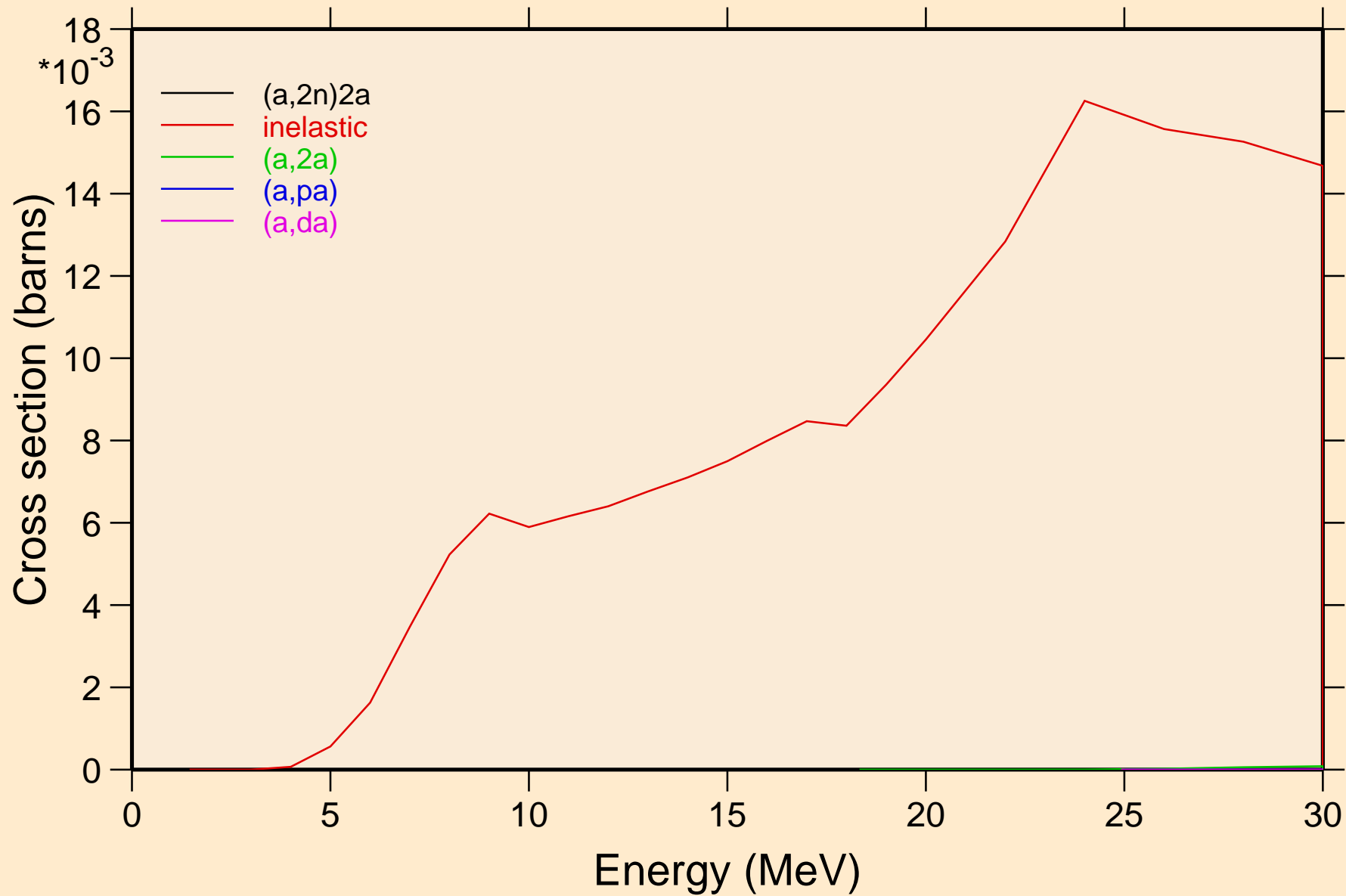

O021 ALPHA ACER TENDL-2024 LIBRARY; T=0.K
angular distribution for elastic

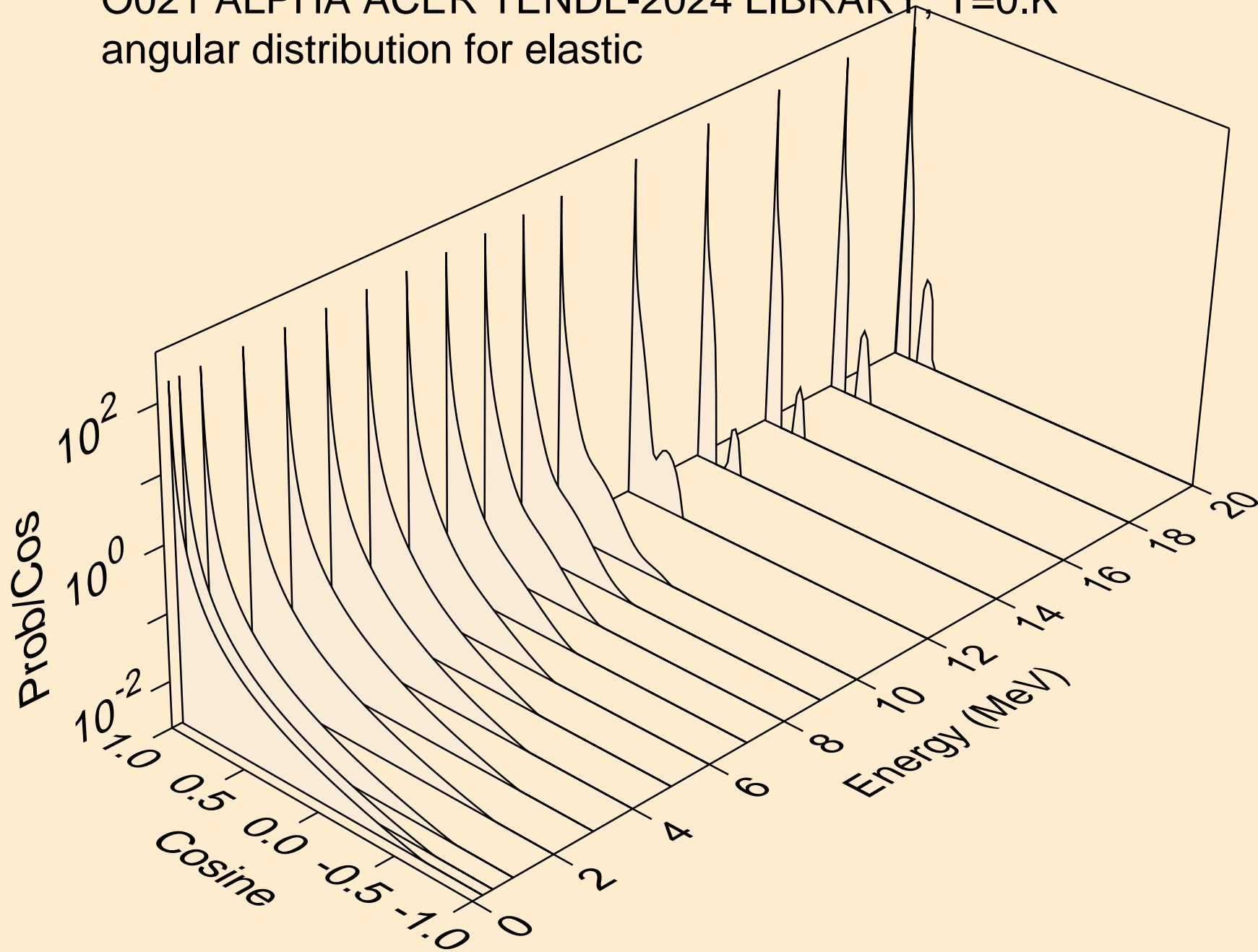

O021 ALPHA ACER TENDL-2024 LIBRARY; T=0.K
angular distribution for elastic

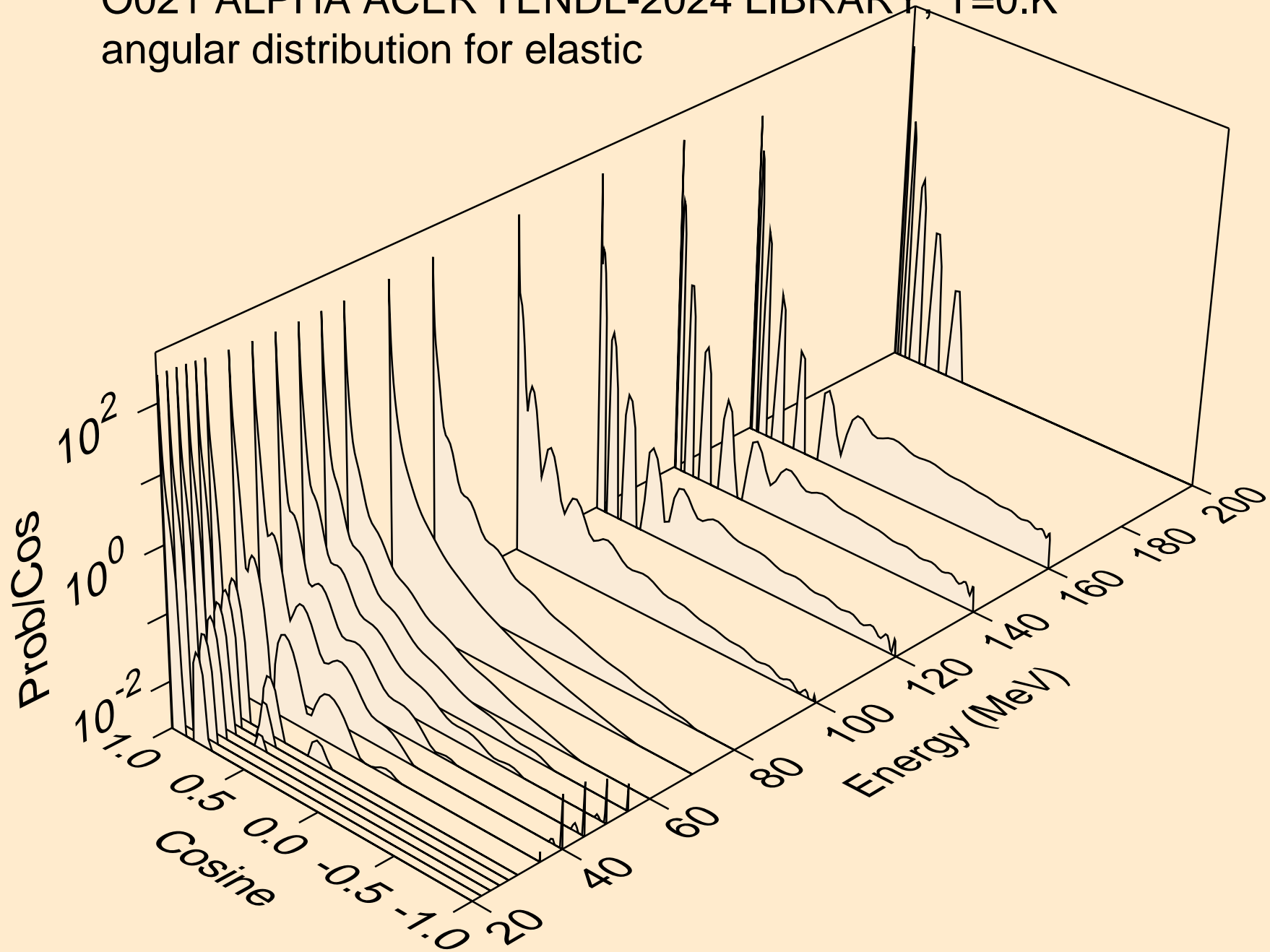

O021 ALPHA ACER TENDL-2024 LIBRARY; T=0.K
Alpha emission for (a,x)

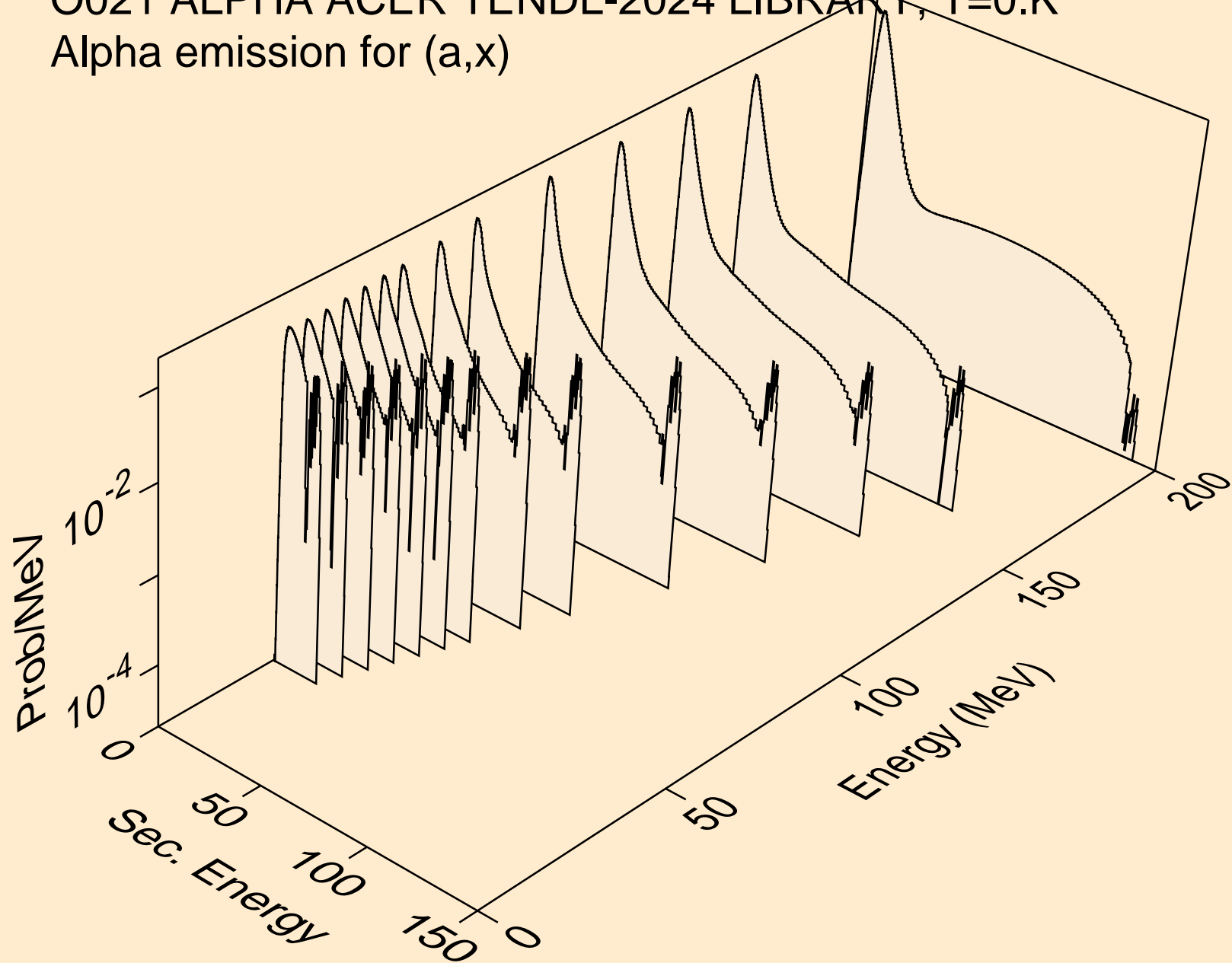

O021 ALPHA ACER TENDL-2024 LIBRARY; T=0.K
Alpha emission for (a,n*)a

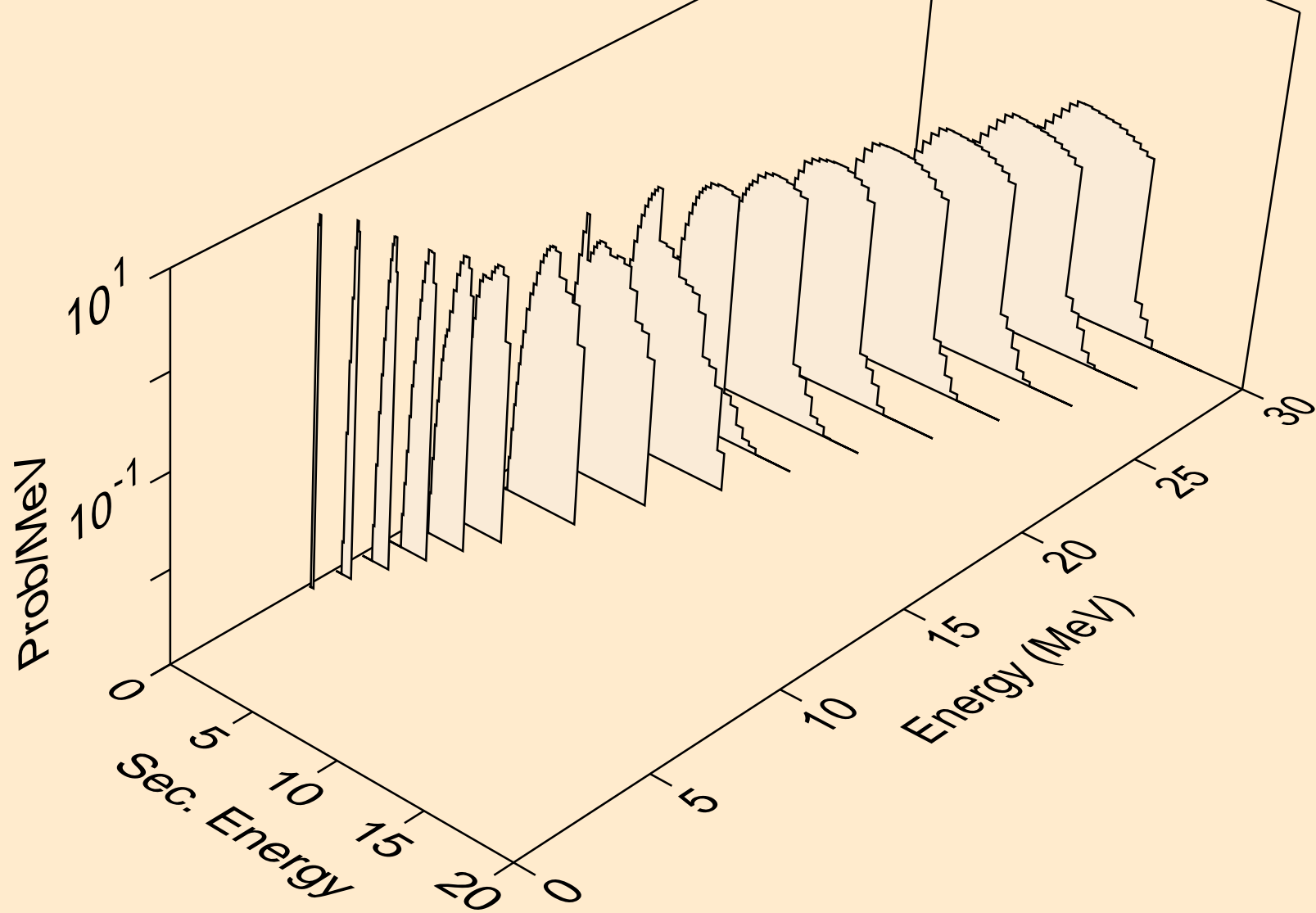

O021 ALPHA ACER TENDL-2024 LIBRARY; T=0.K
Alpha emission for (a,2n)a

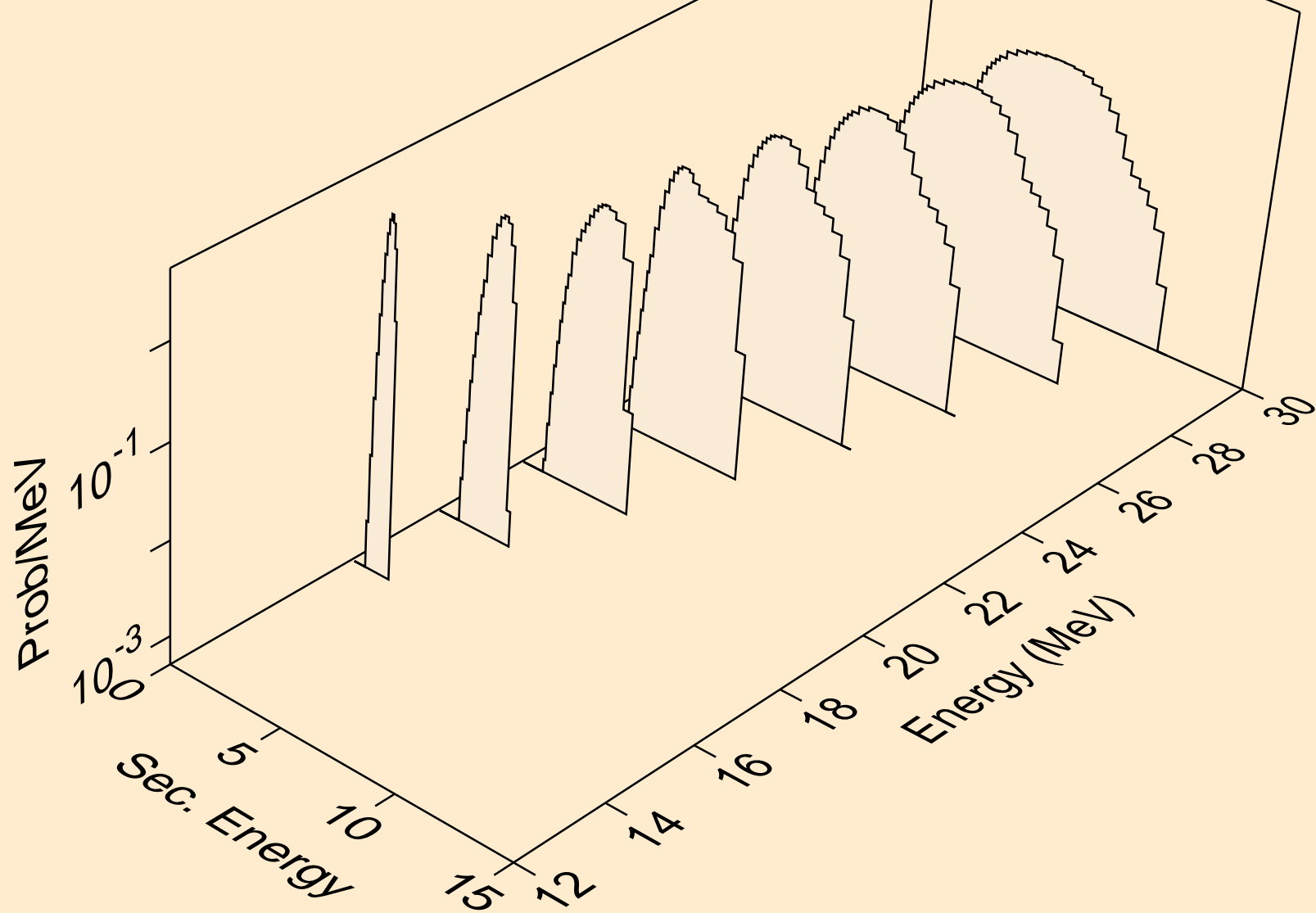

O021 ALPHA ACER TENDL-2024 LIBRARY; T=0.K
Alpha emission for (a,3n)a

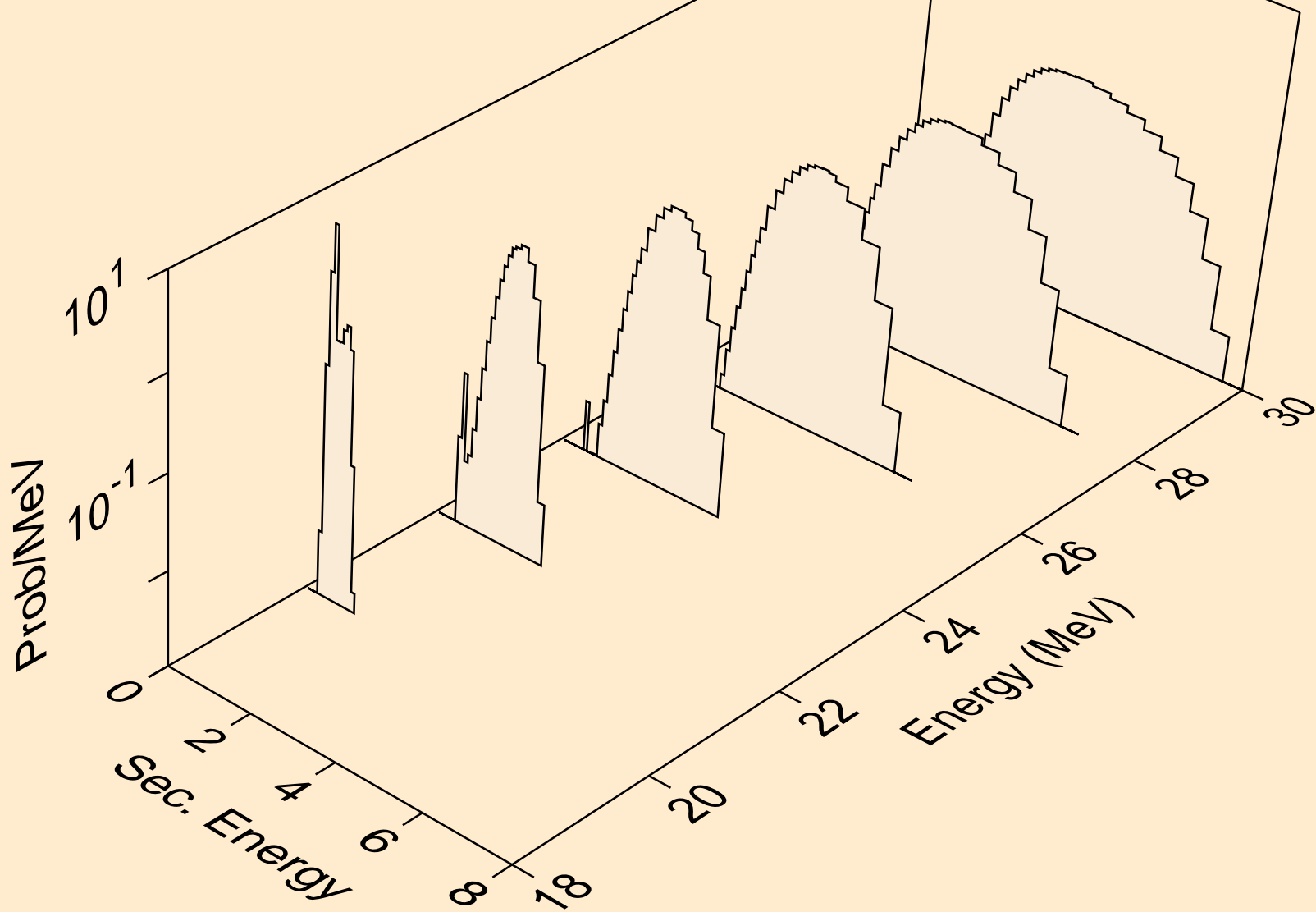

O021 ALPHA ACER TENDL-2024 LIBRARY; T=0.K
Alpha emission for (a,n*)2a

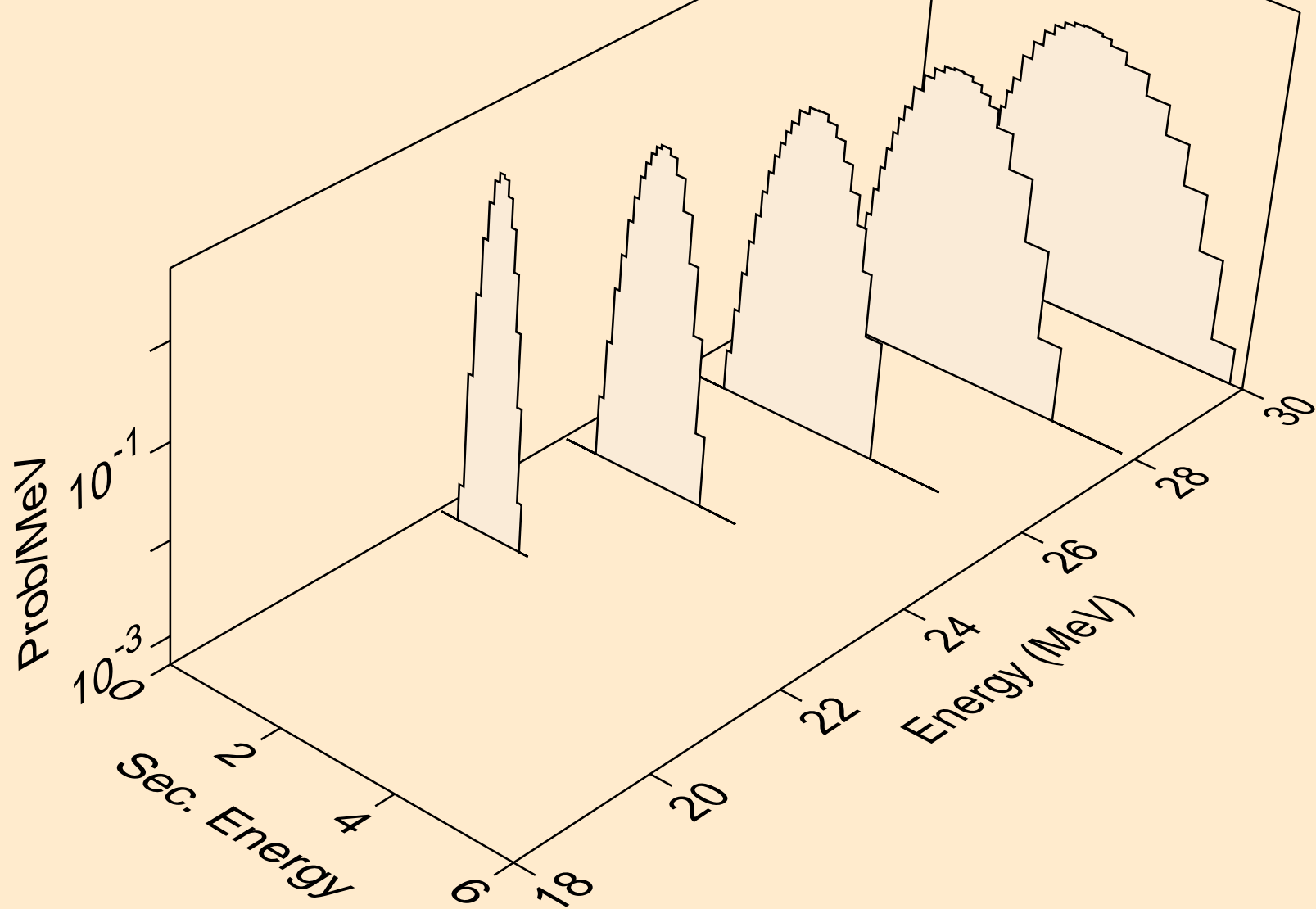

O021 ALPHA ACER TENDL-2024 LIBRARY; T=0.K
Alpha emission for (a,2n)2a

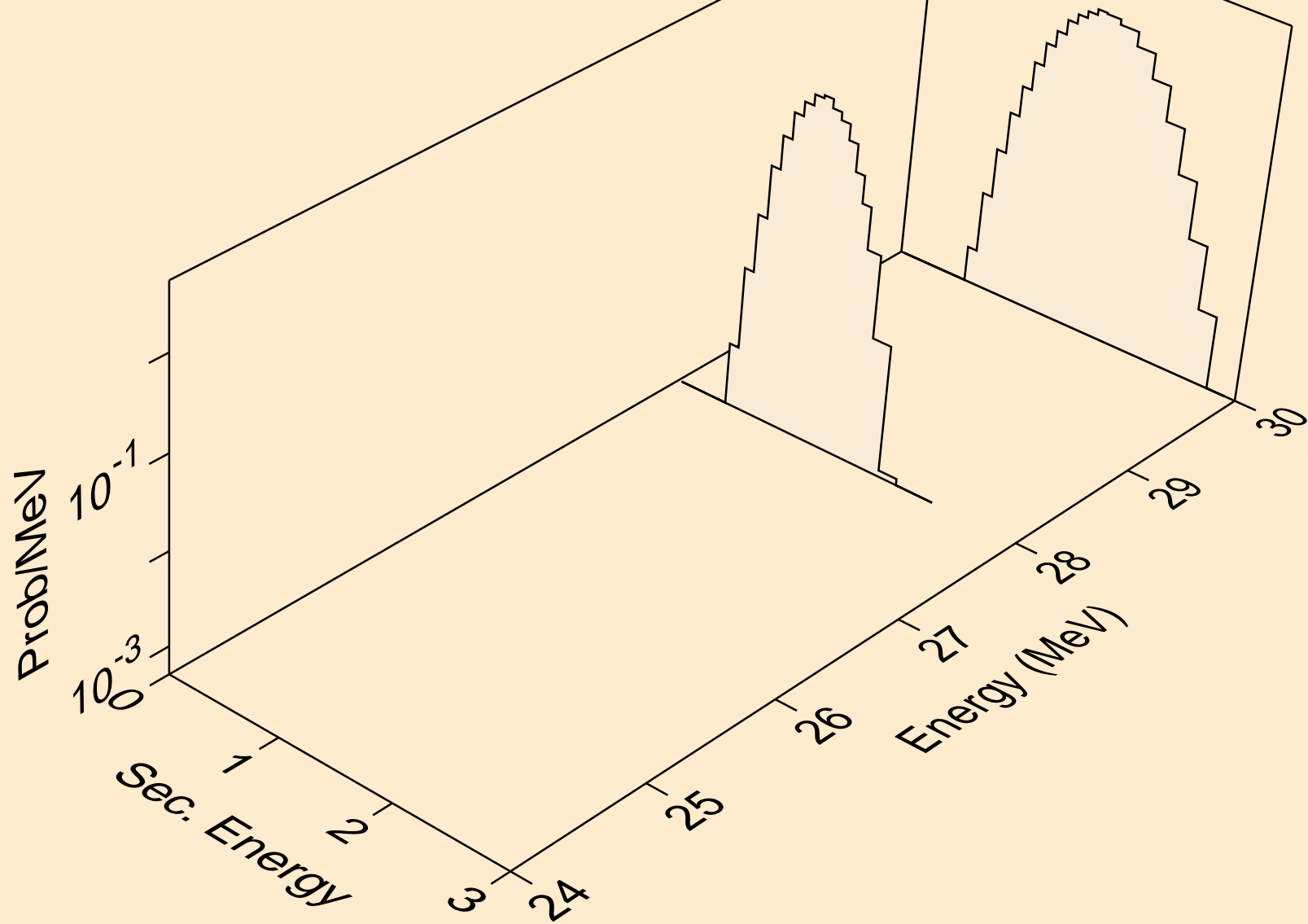

O021 ALPHA ACER TENDL-2024 LIBRARY; T=0.K
Alpha emission for inelastic

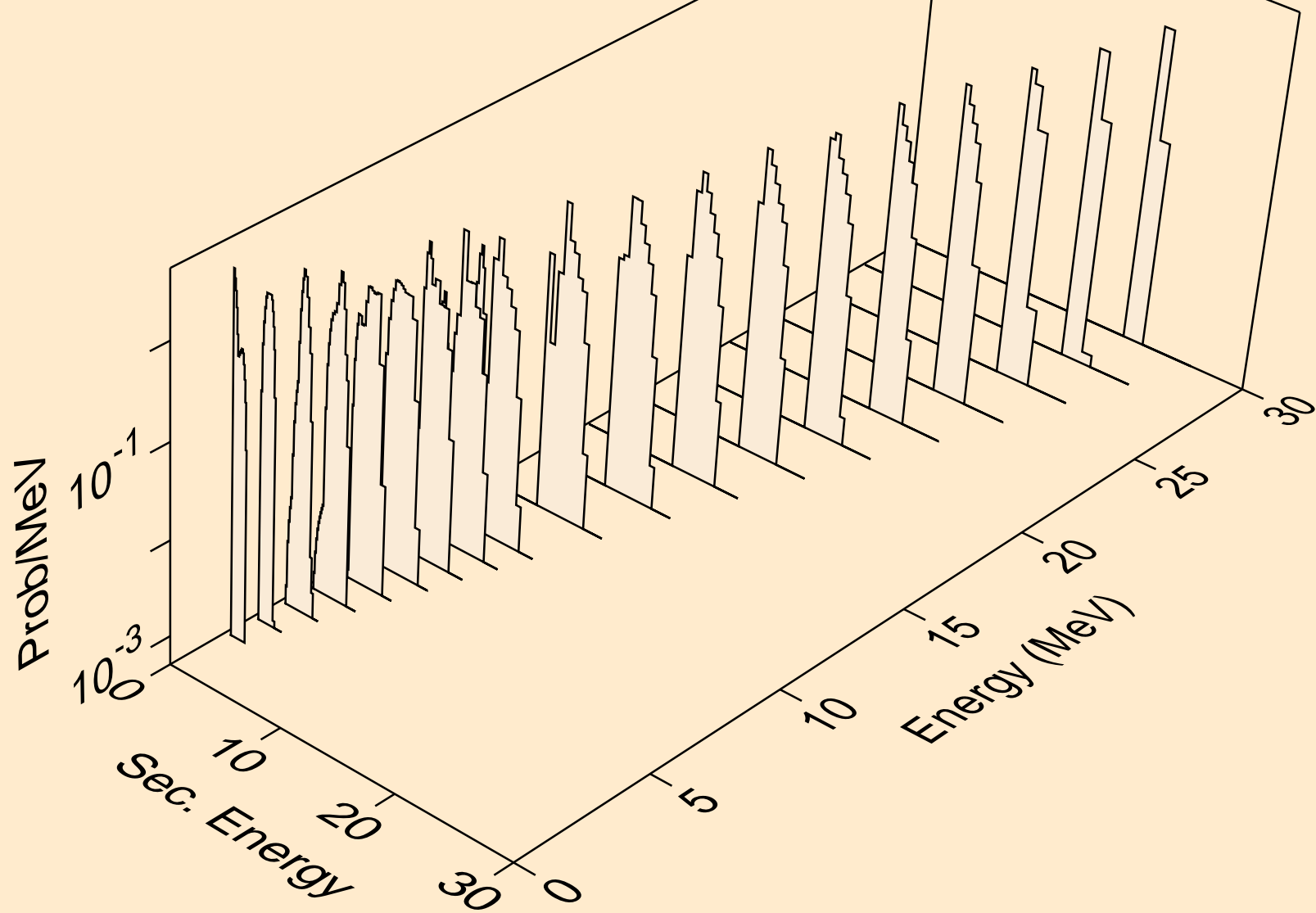

O021 ALPHA ACER TENDL-2024 LIBRARY; T=0.K
Alpha emission for (a,2a)

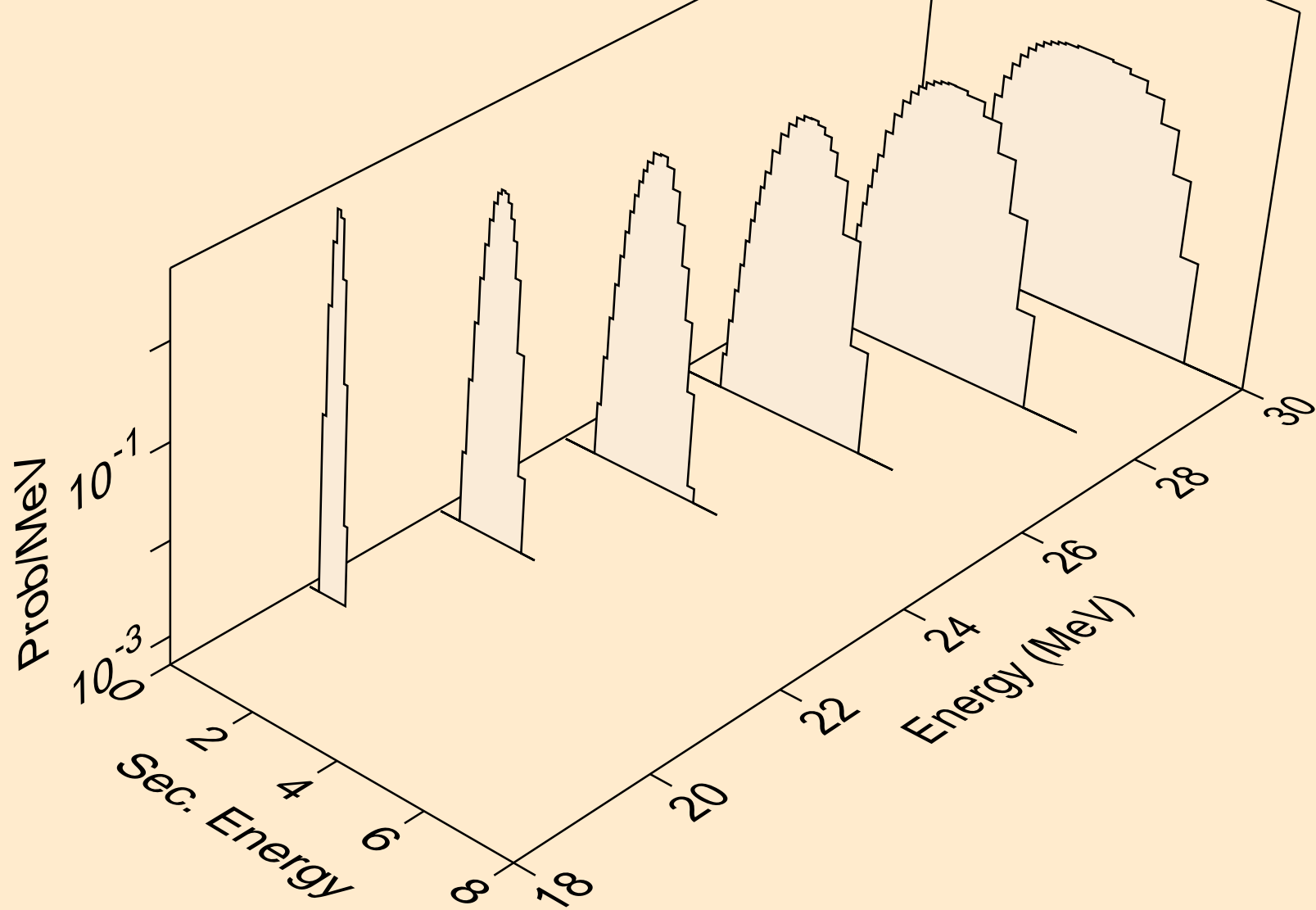

O021 ALPHA ACER TENDL-2024 LIBRARY; T=0.K
Alpha emission for (a,pa)

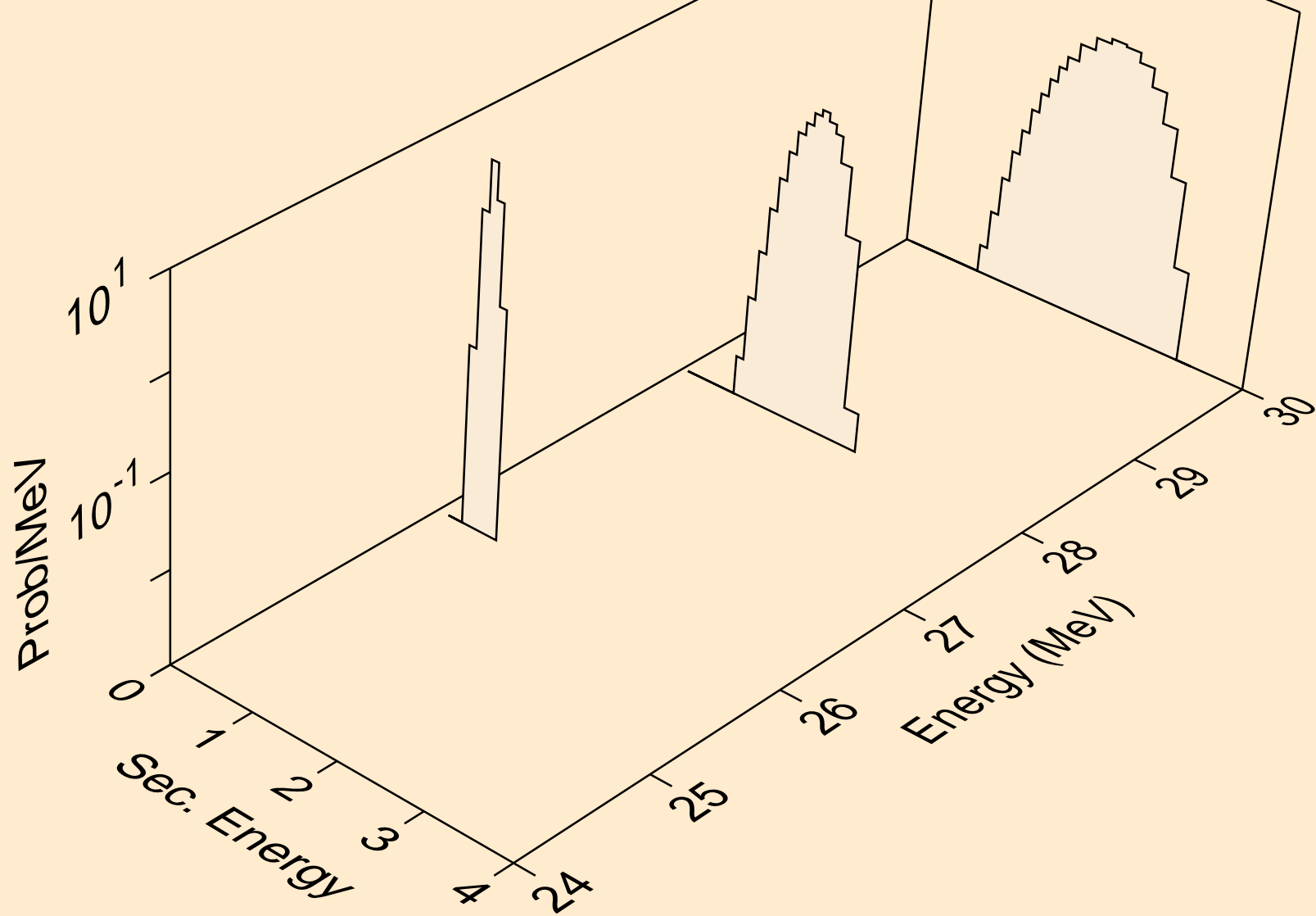

O021 ALPHA ACER TENDL-2024 LIBRARY; T=0.K
Alpha emission for (a,da)

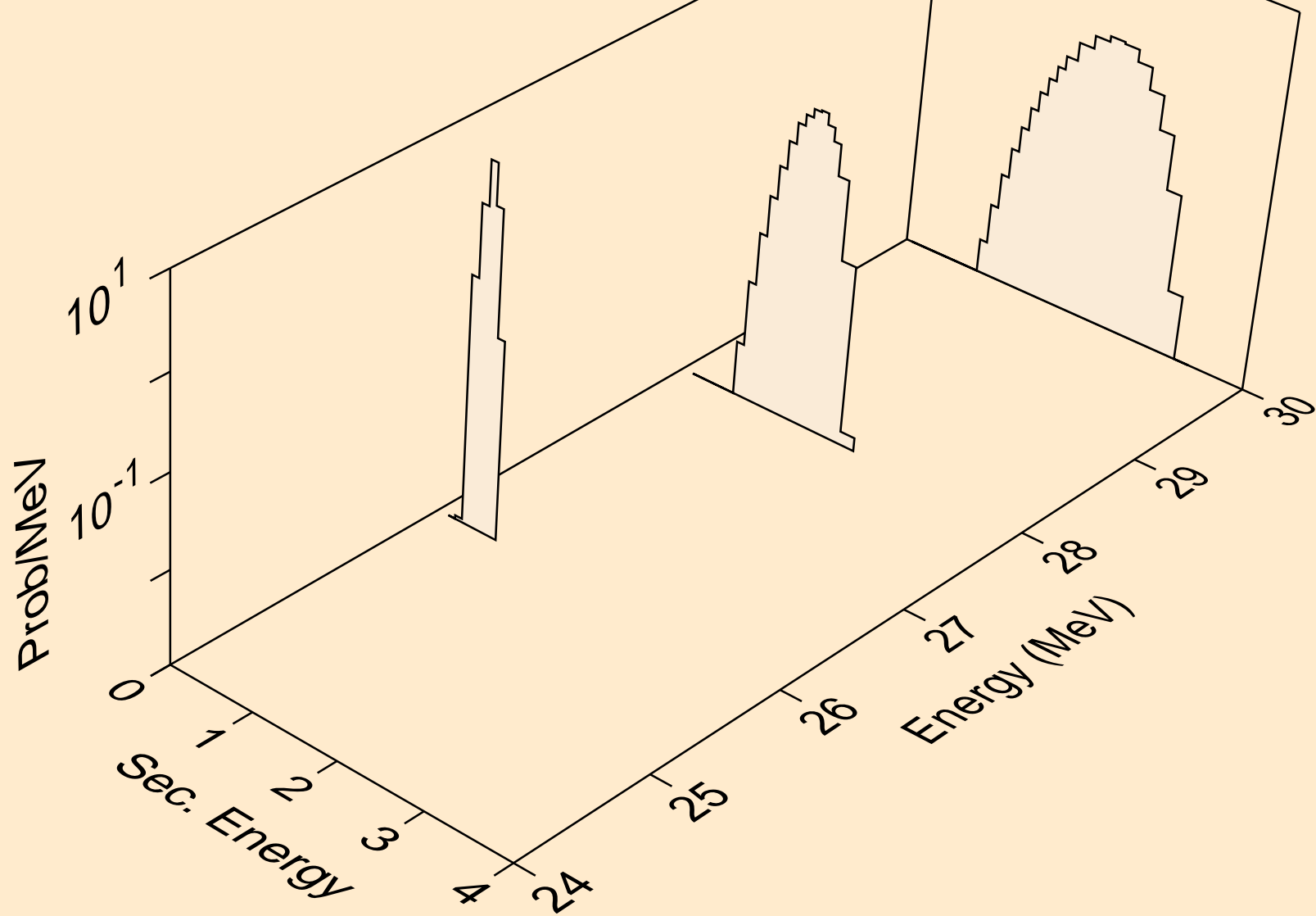

O021 ALPHA ACER TENDL-2024 LIBRARY; T=0.K
Photon emission for (z,n)

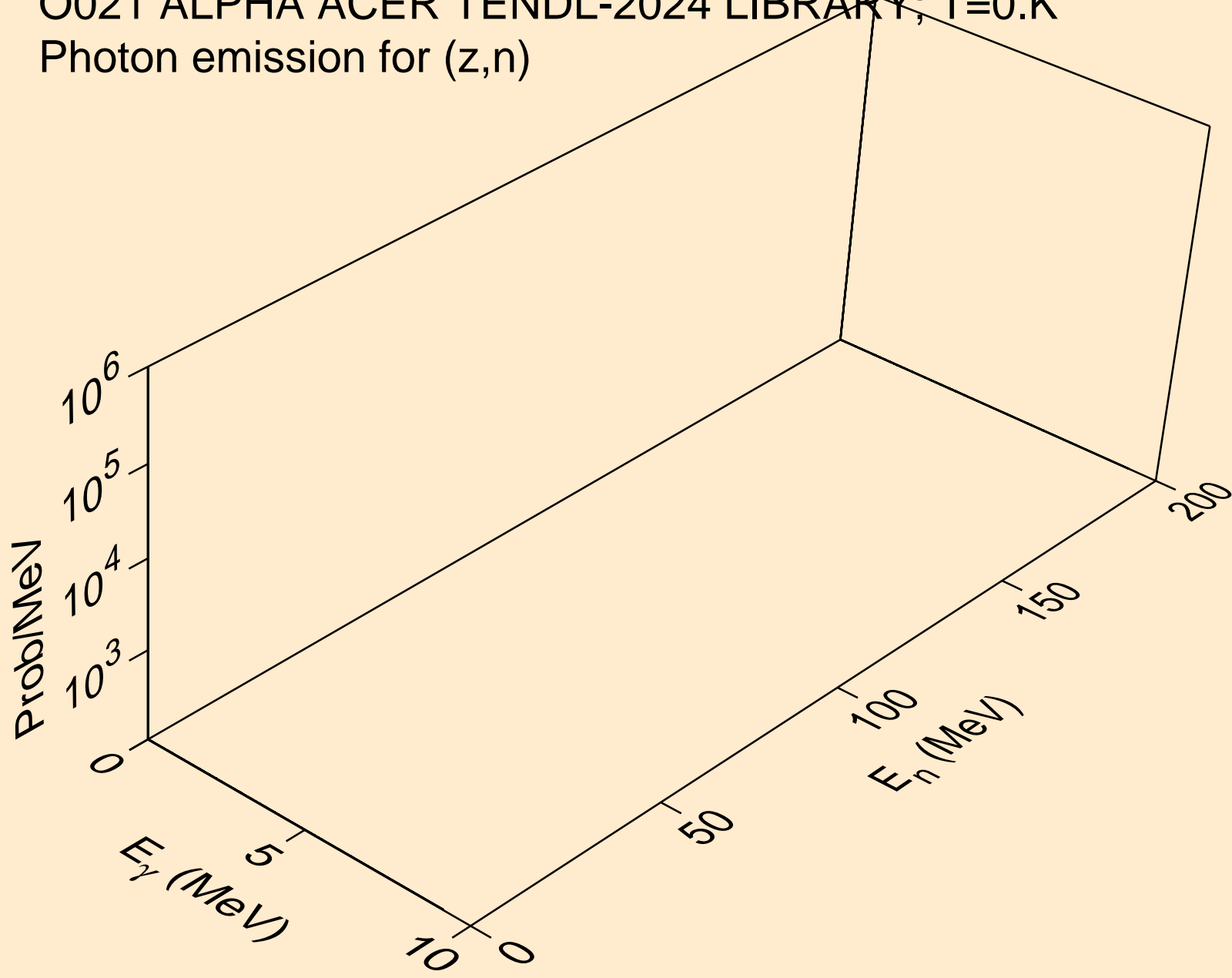

O021 ALPHA ACER TENDL-2024 LIBRARY; T=0.K
Photon emission for (z,x)

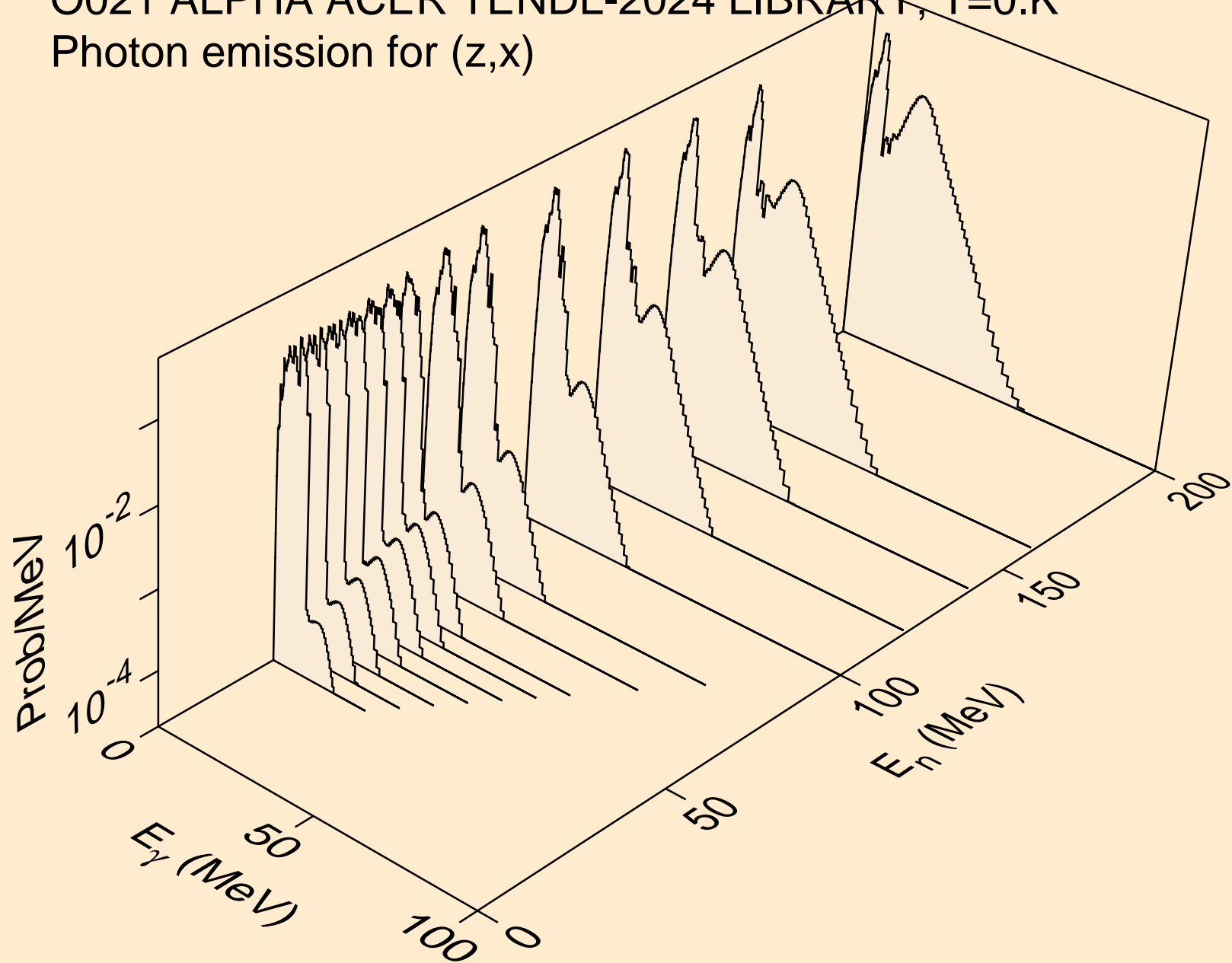

O021 ALPHA ACER TENDL-2024 LIBRARY; T=0.K
Photon emission for (n,2nd)

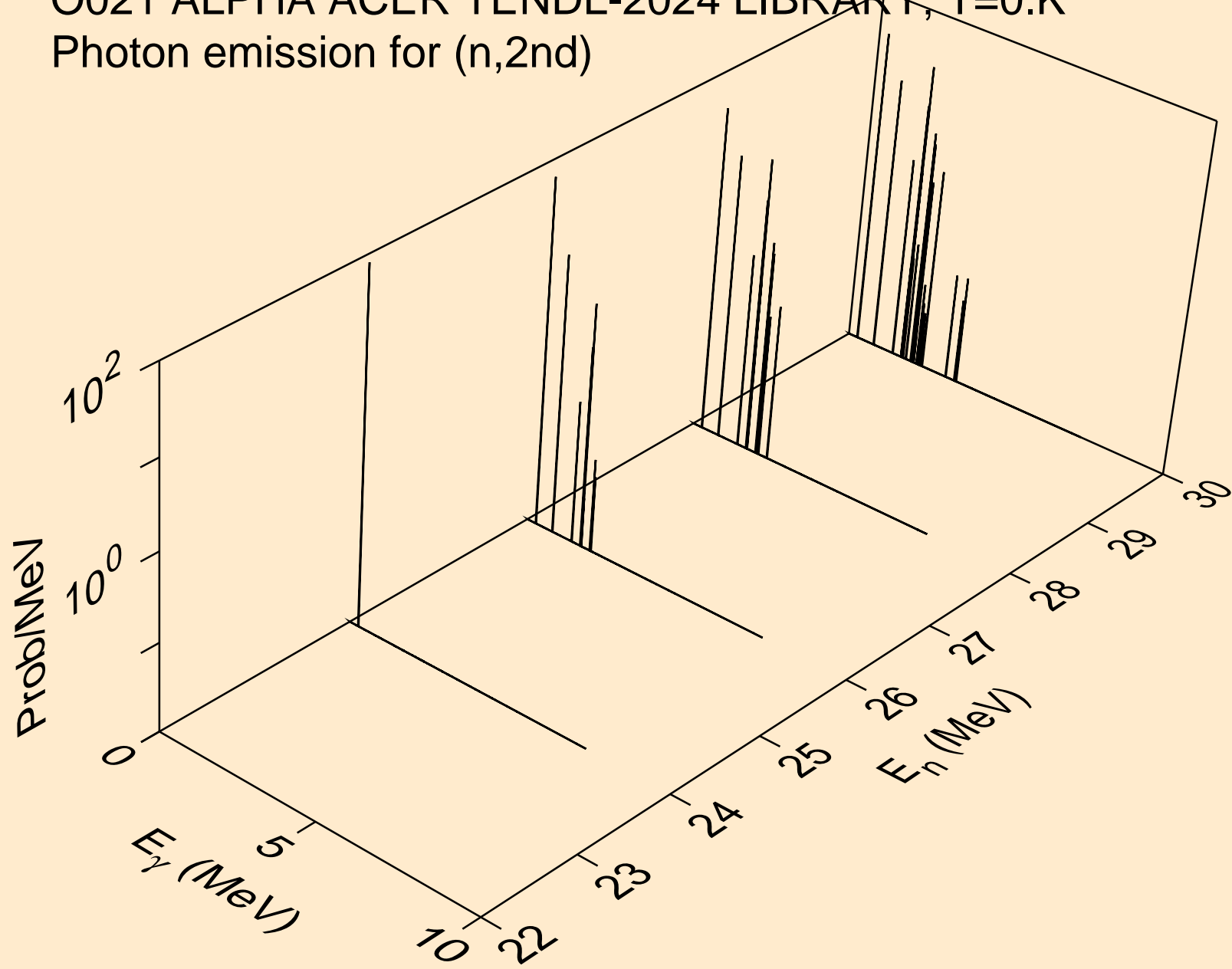

O021 ALPHA ACER TENDL-2024 LIBRARY; T=0.K
Photon emission for (n,2n)

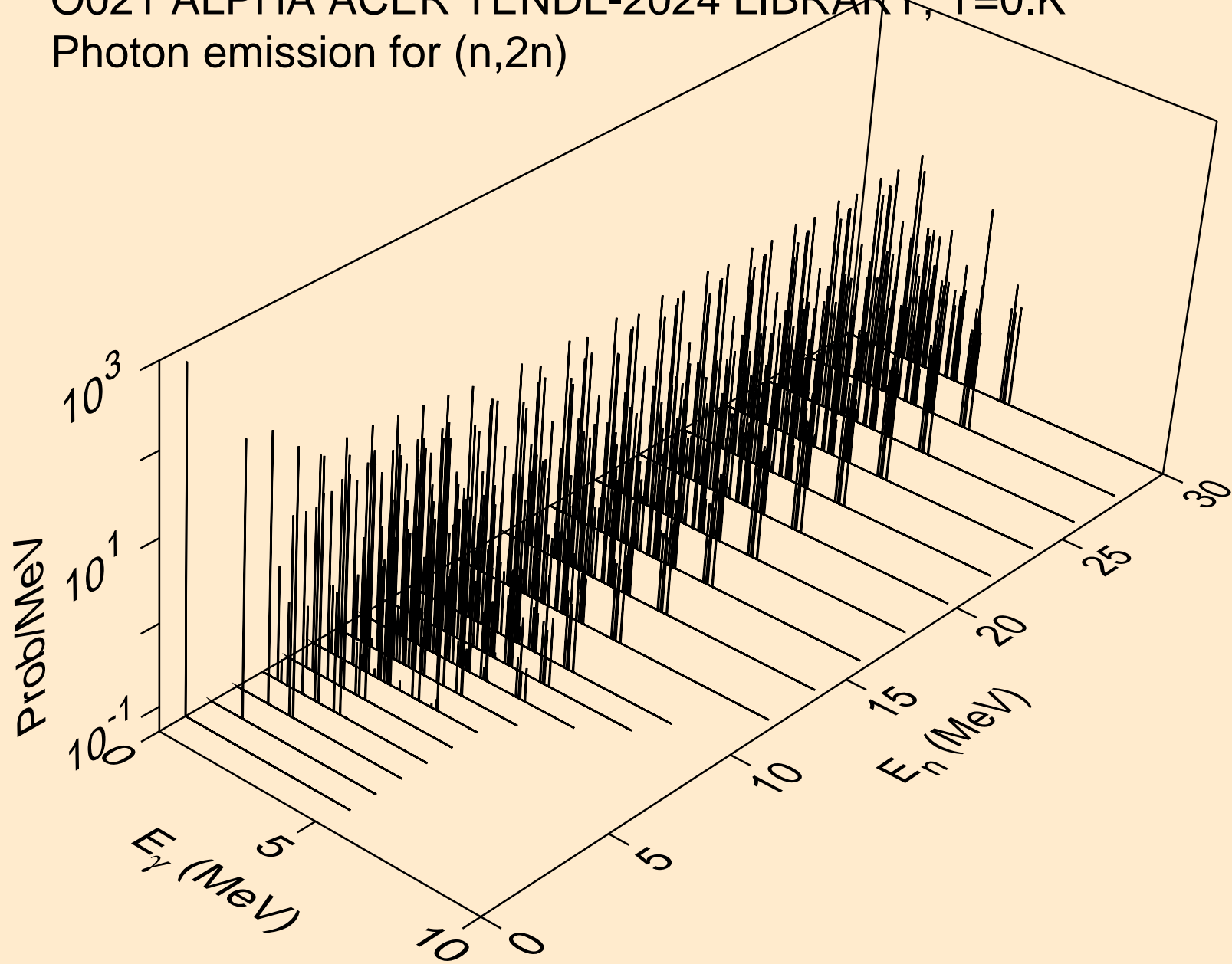

O021 ALPHA ACER TENDL-2024 LIBRARY; T=0.K
Photon emission for (n,3n)

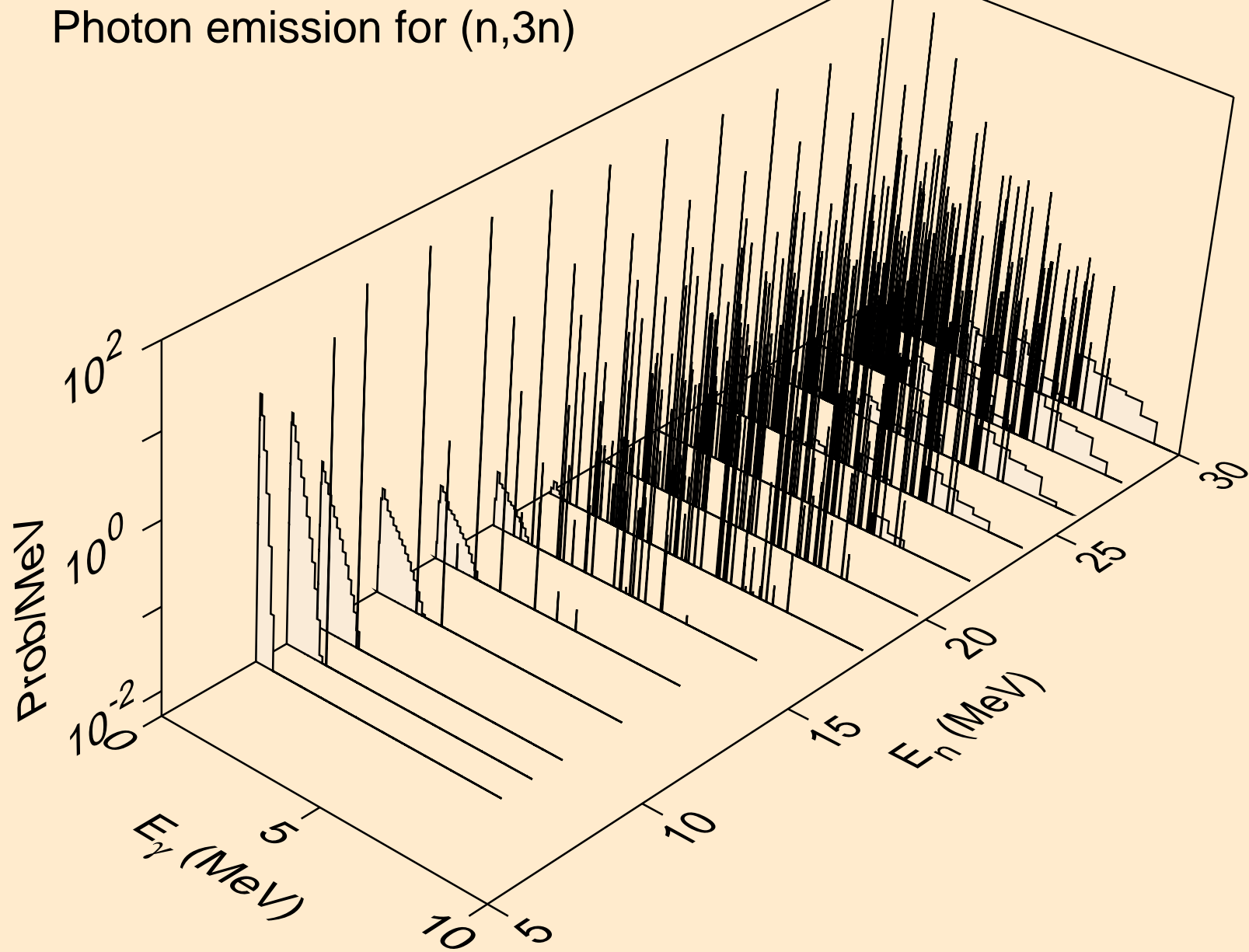

O021 ALPHA ACER TENDL-2024 LIBRARY; T=0.K
Photon emission for (n,n*)a

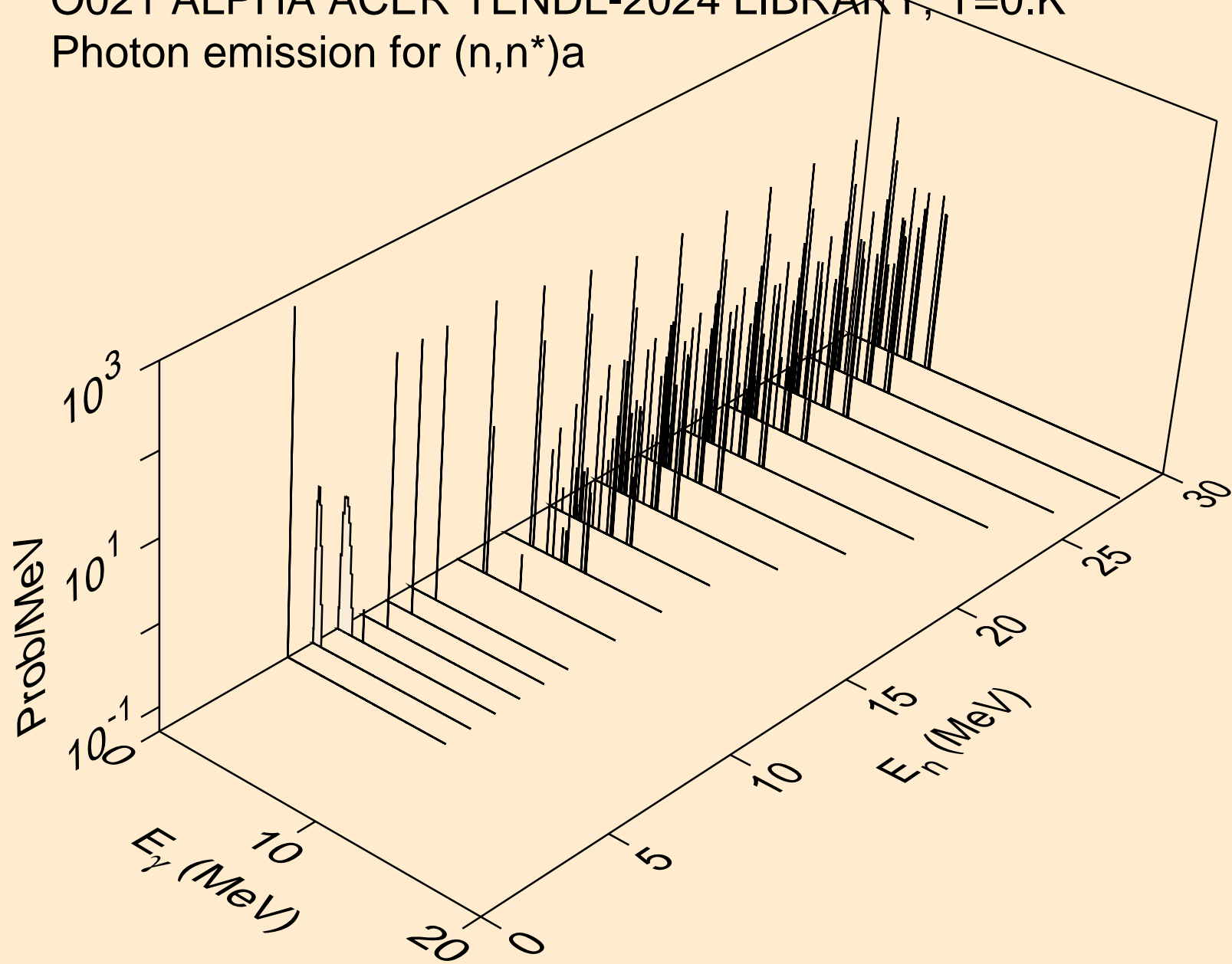

O021 ALPHA ACER TENDL-2024 LIBRARY; T=0.K
Photon emission for (n,2n)a

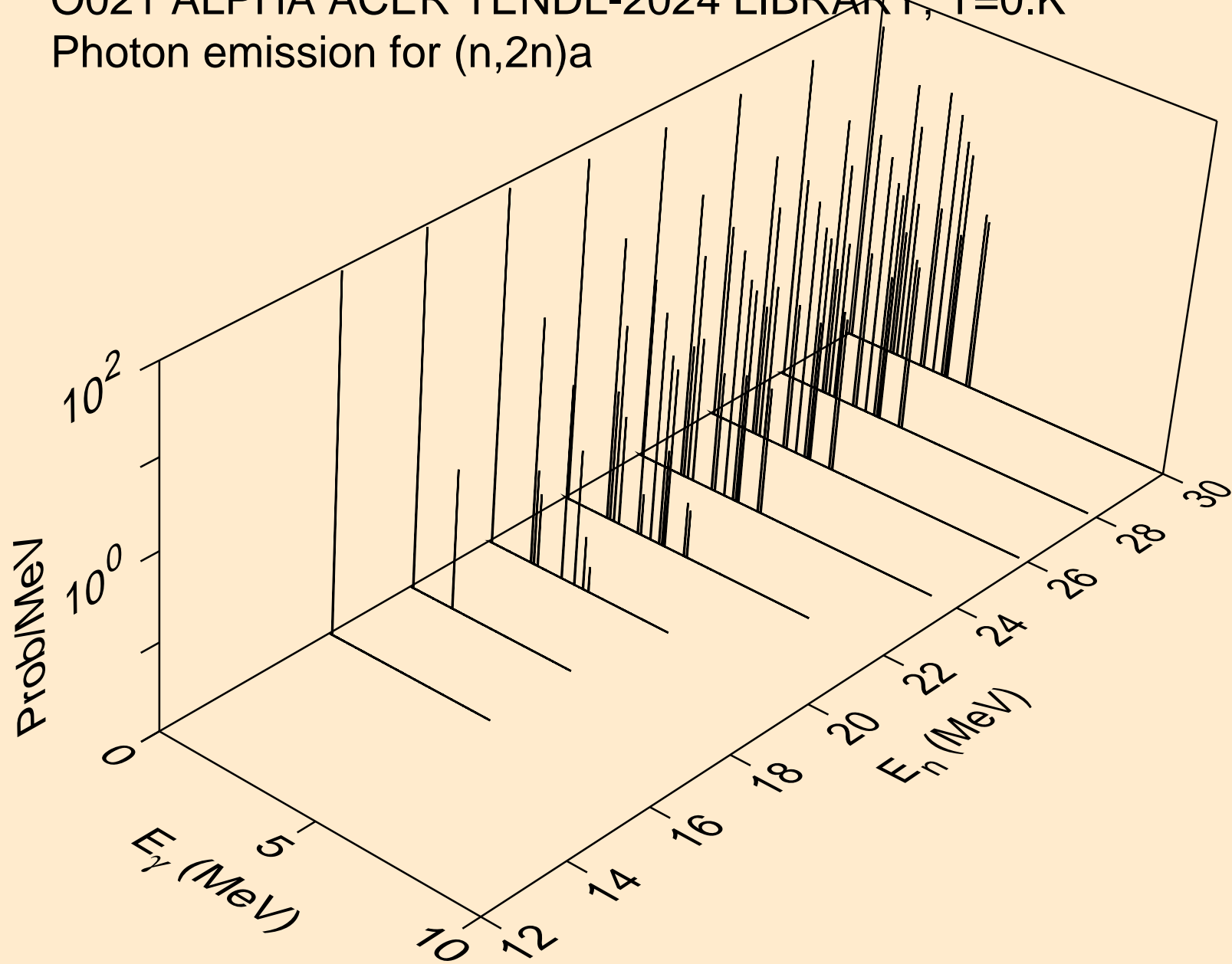

O021 ALPHA ACER TENDL-2024 LIBRARY; T=0.K
Photon emission for (n,3n)a

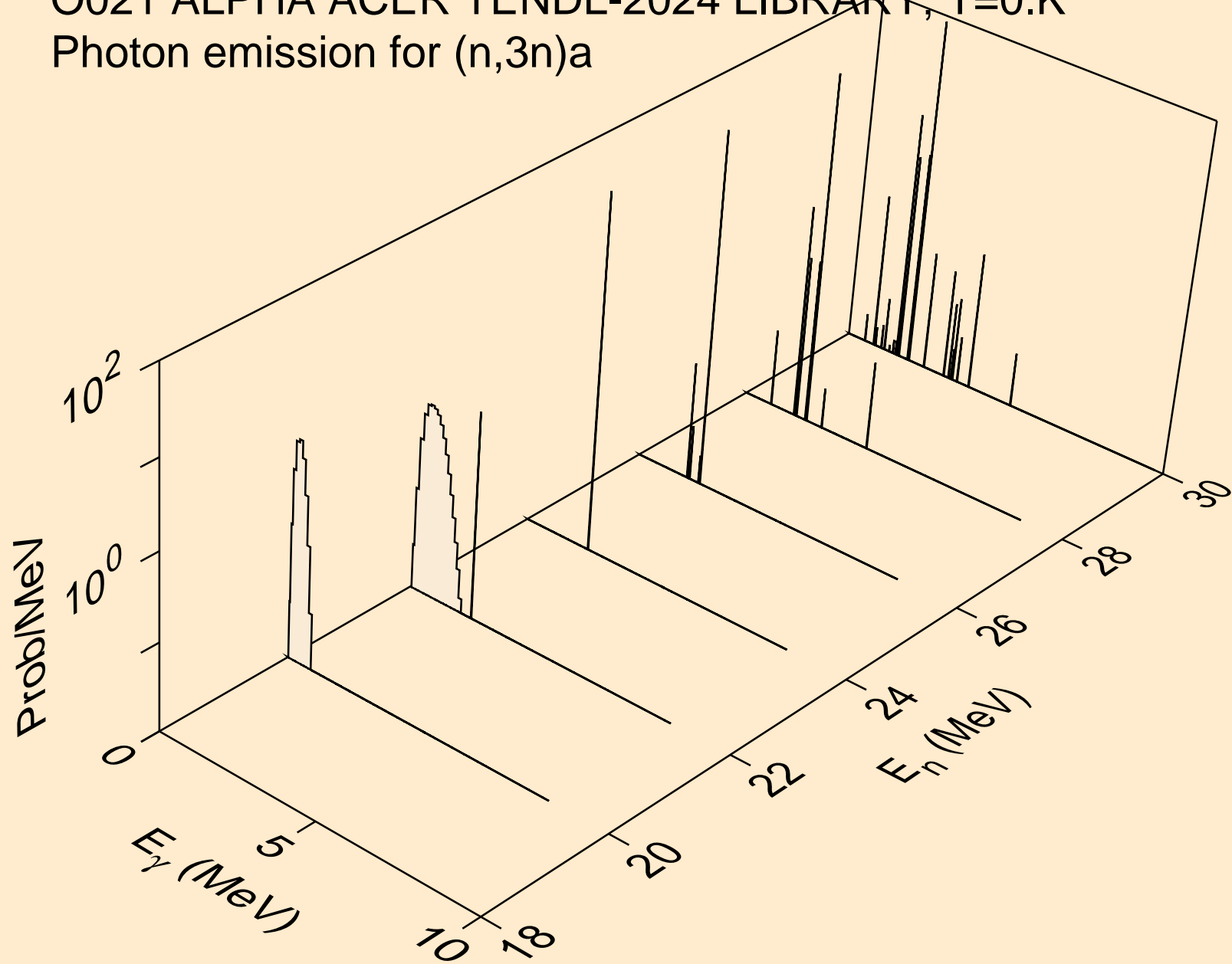

O021 ALPHA ACER TENDL-2024 LIBRARY; T=0.K
Photon emission for (n,n*)p

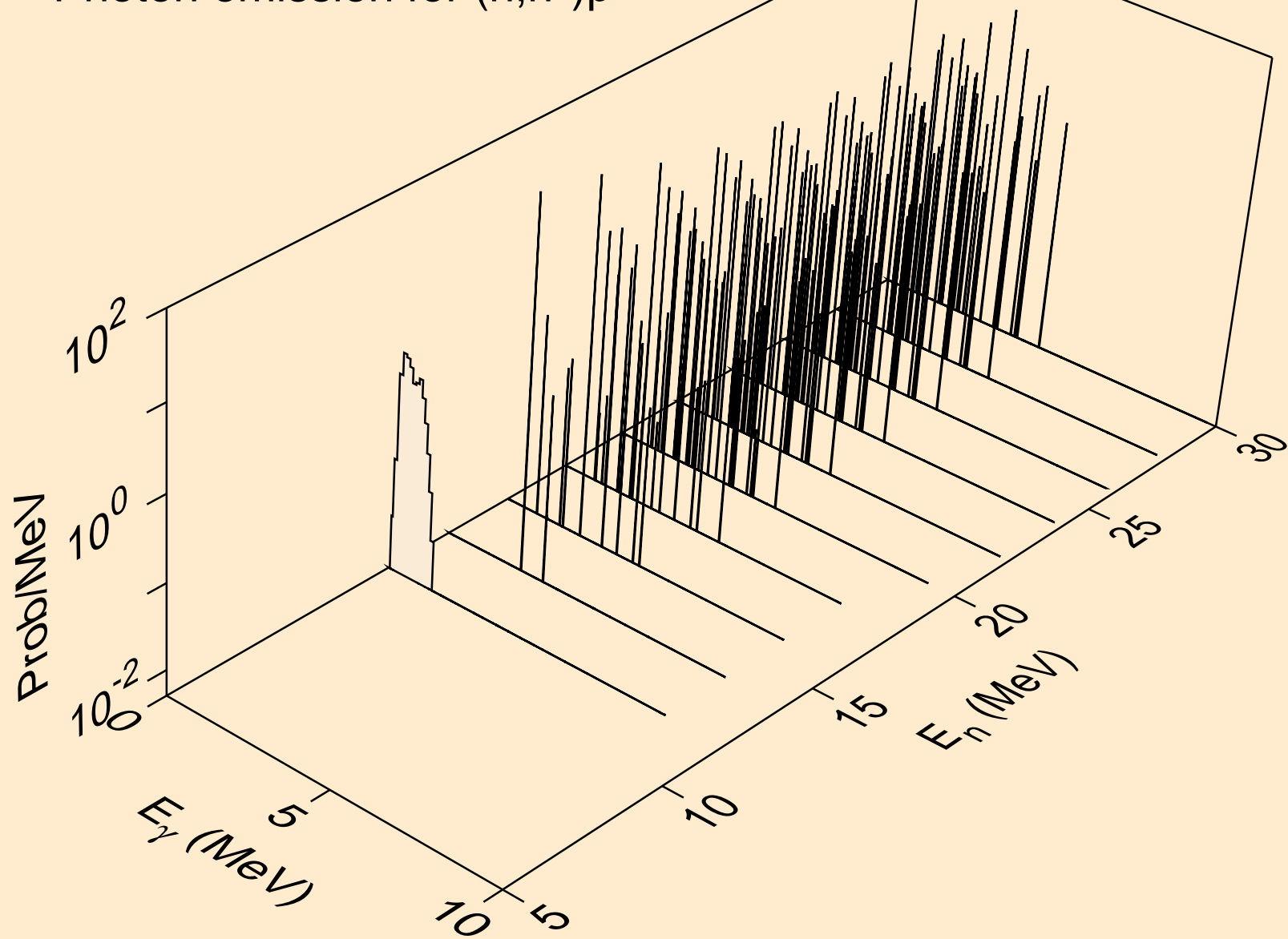

O021 ALPHA ACER TENDL-2024 LIBRARY; T=0.K
Photon emission for (n,n*)2a

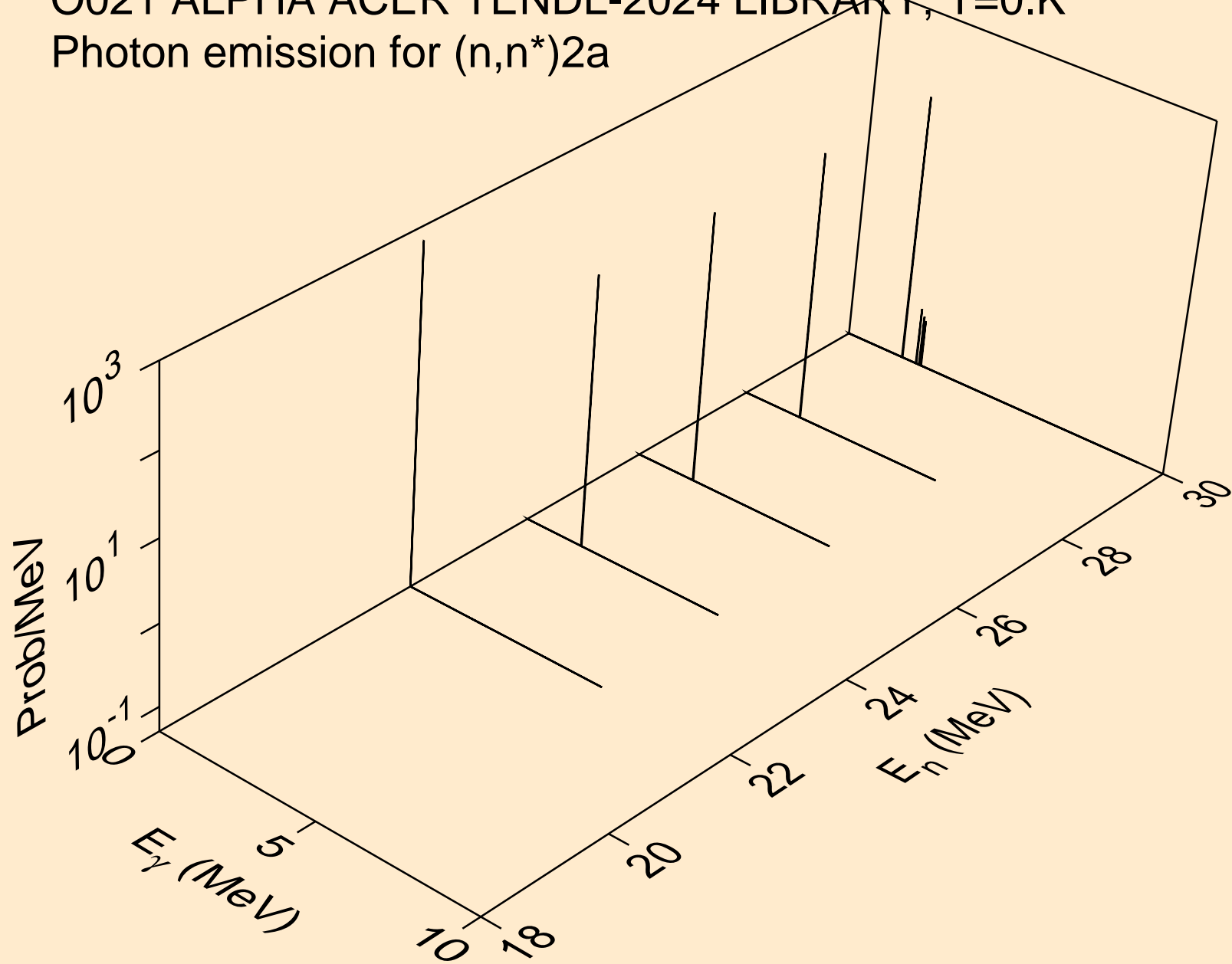

O021 ALPHA ACER TENDL-2024 LIBRARY; T=0.K
Photon emission for (n,2n)2a

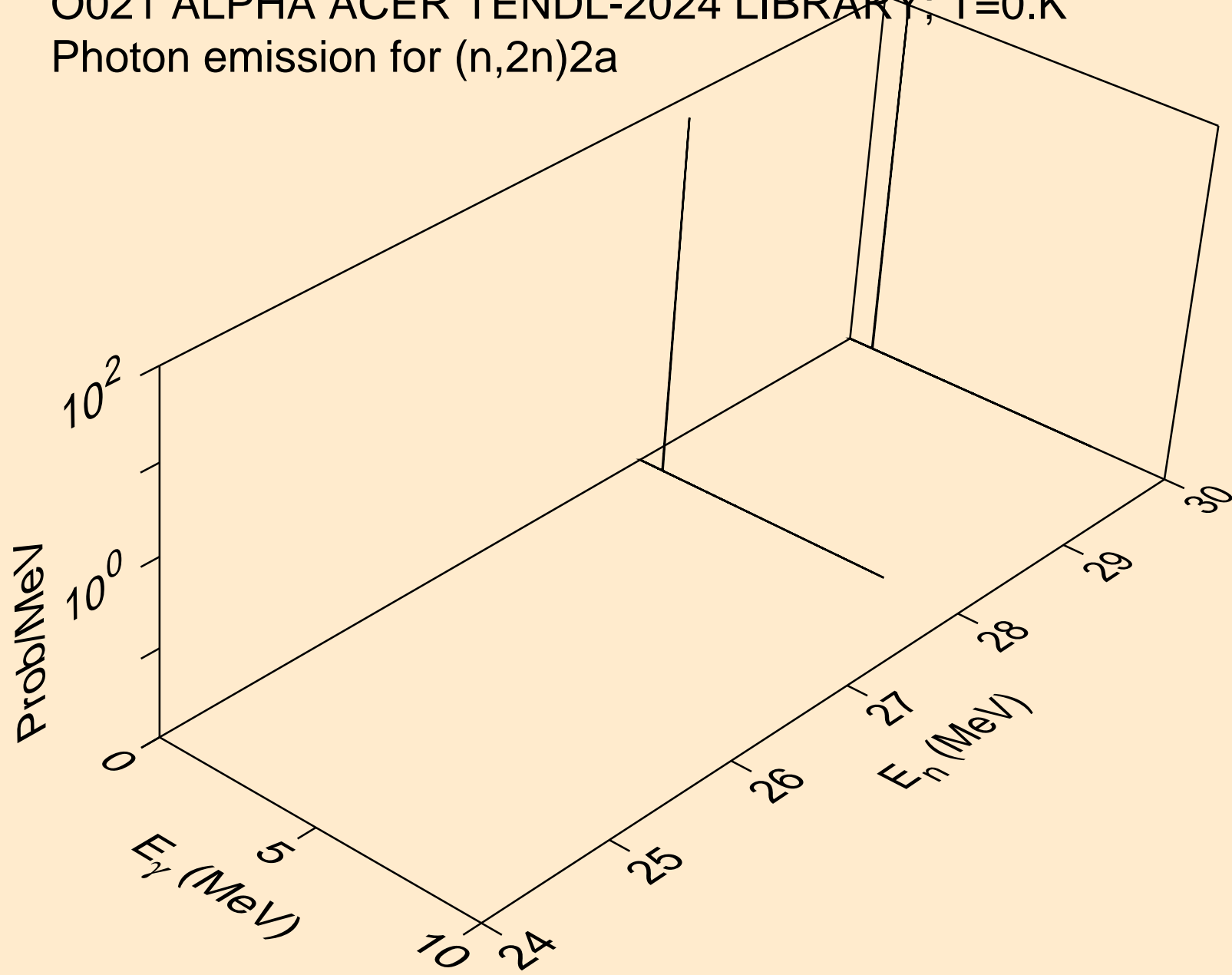

O021 ALPHA ACER TENDL-2024 LIBRARY; T=0.K
Photon emission for (n,n*)d

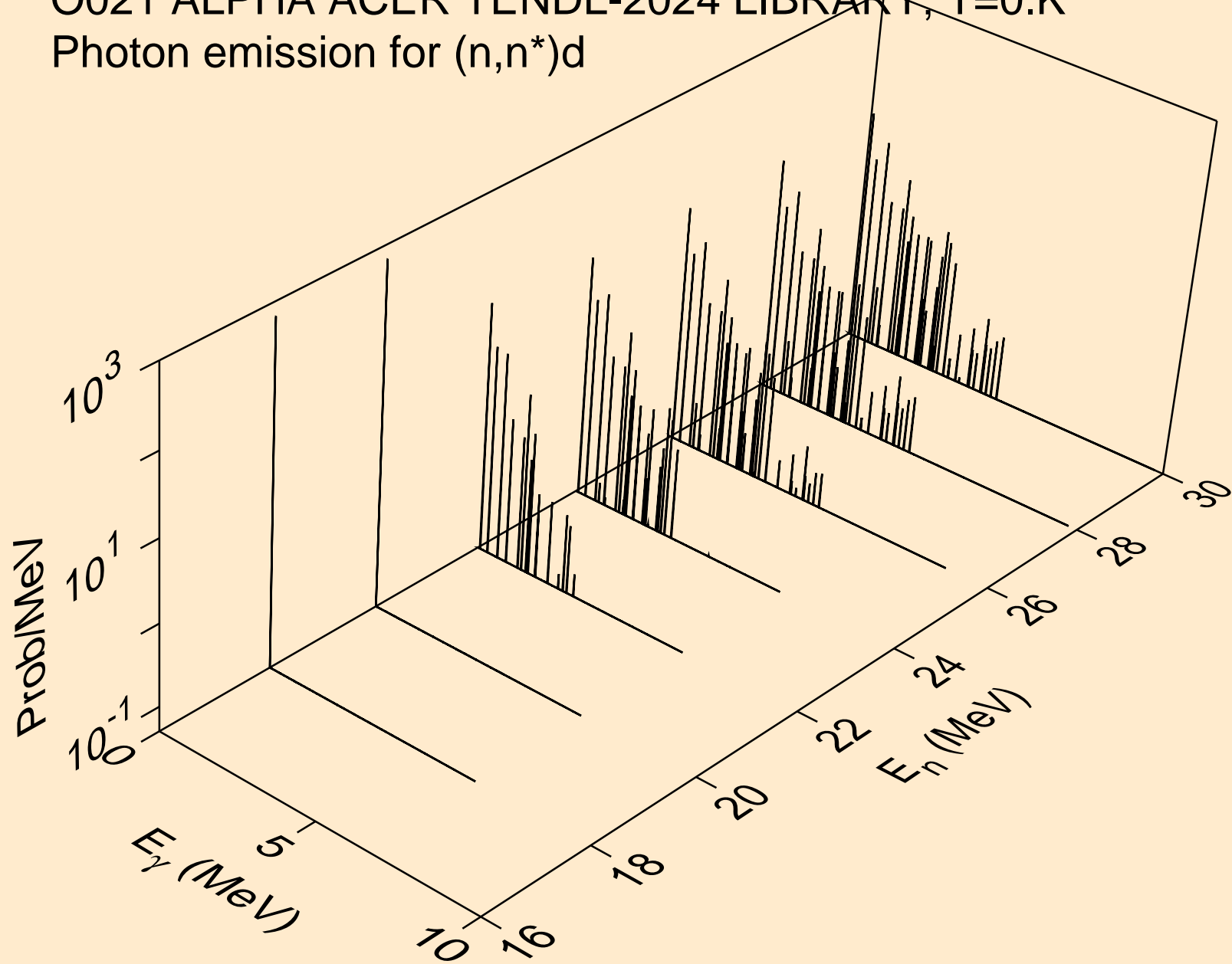

O021 ALPHA ACER TENDL-2024 LIBRARY; T=0.K
Photon emission for (n,n*)t

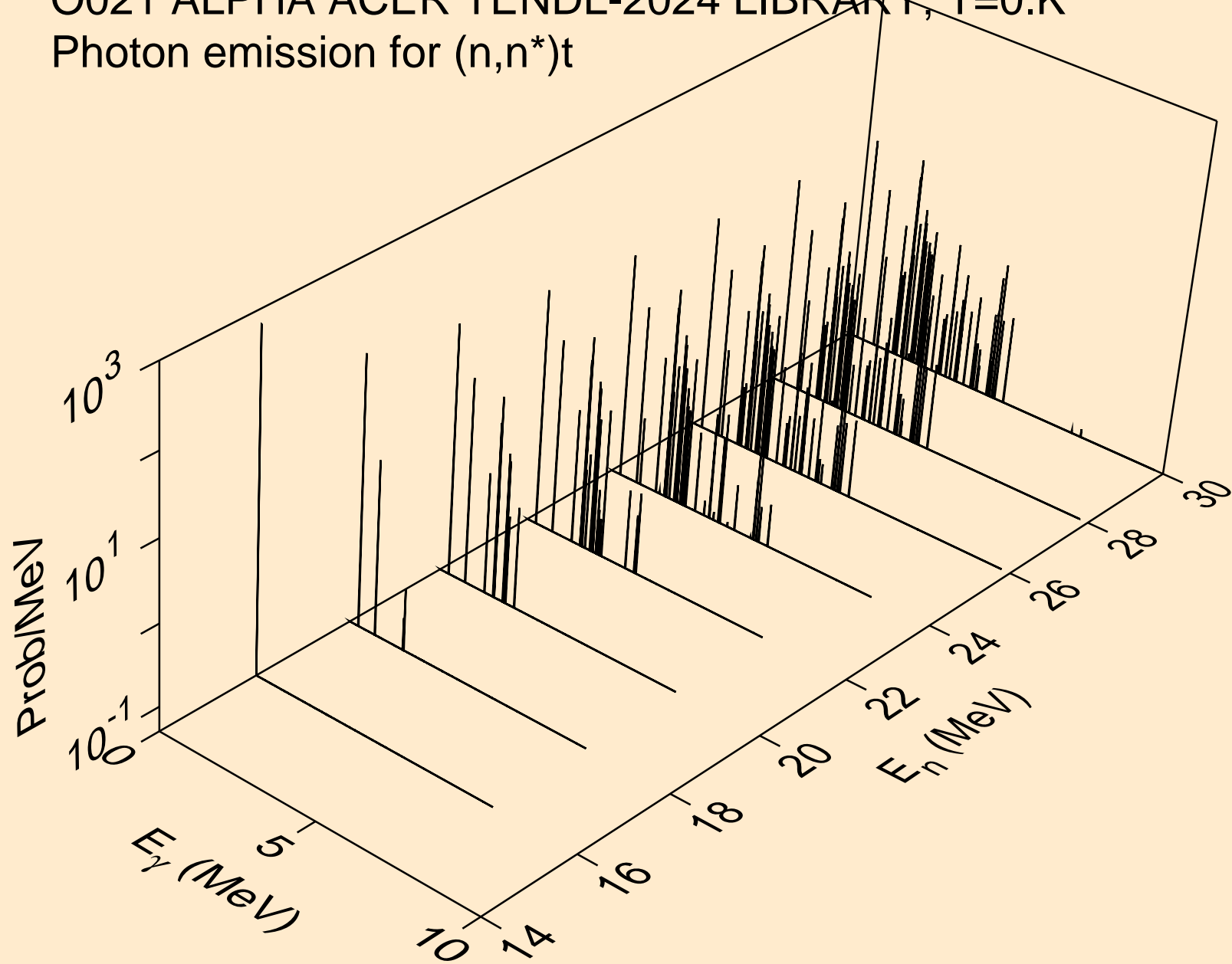

O021 ALPHA ACER TENDL-2024 LIBRARY; T=0.K
Photon emission for (n,n*)he3

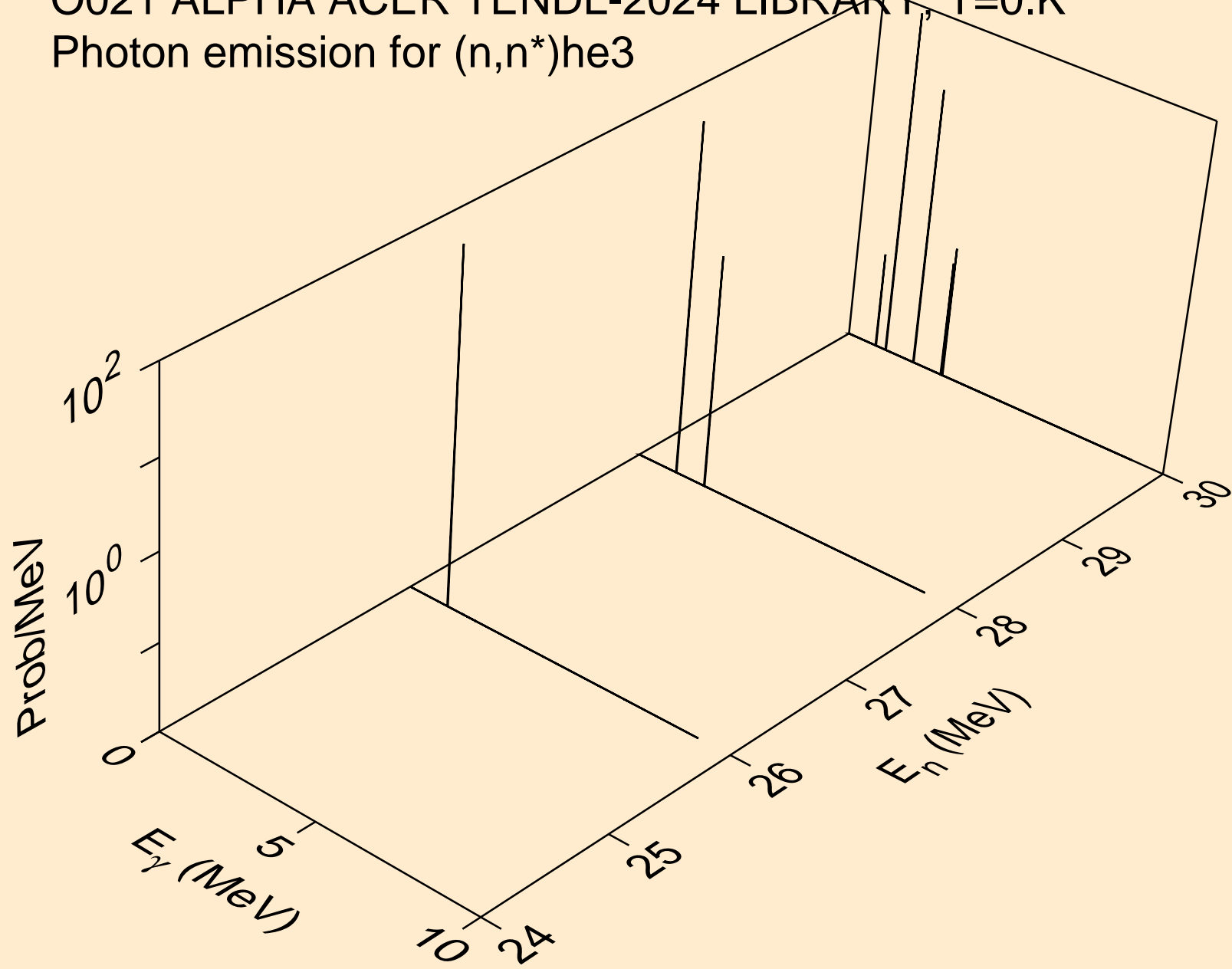

O021 ALPHA ACER TENDL-2024 LIBRARY; T=0.K
Photon emission for (n,4n)

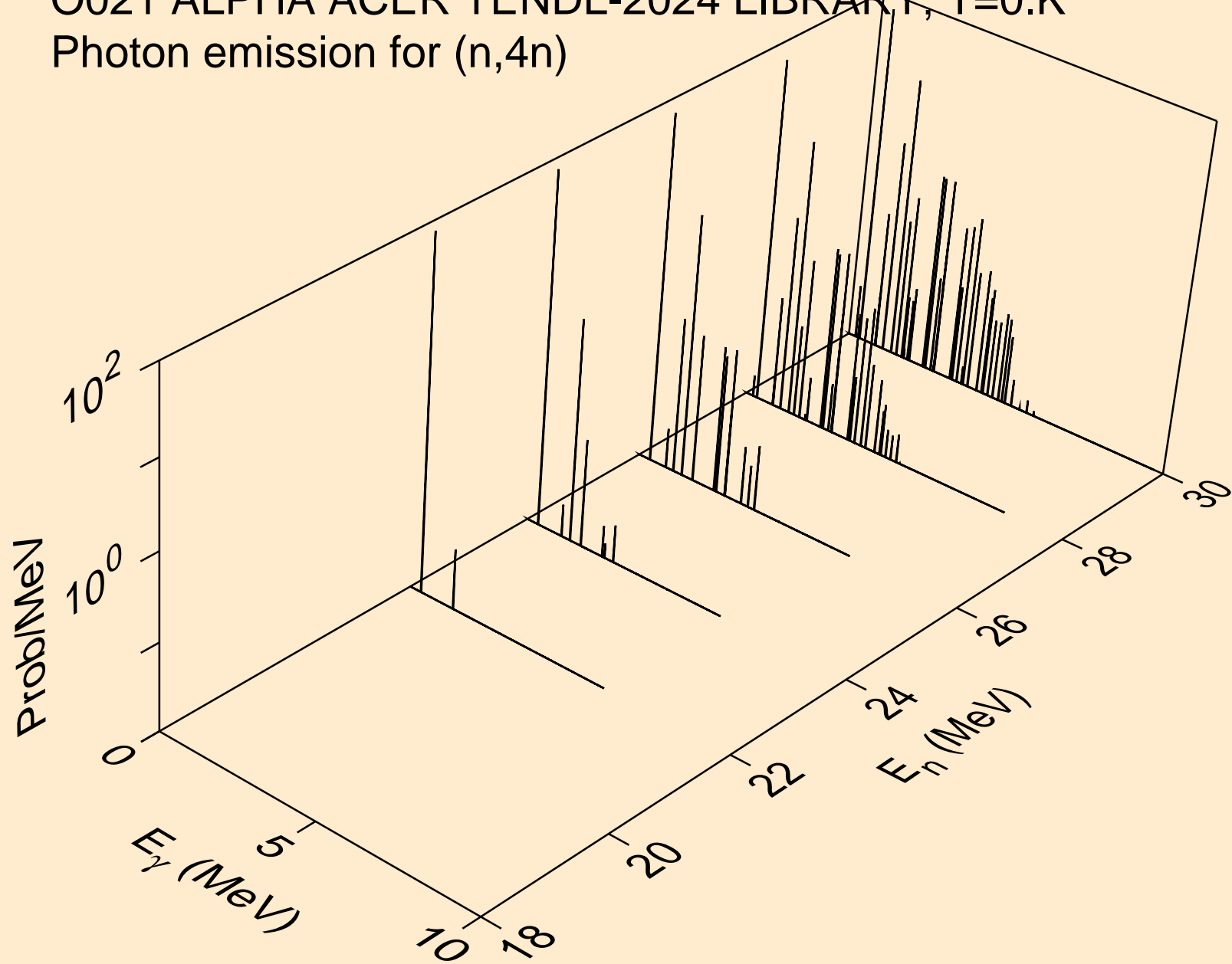

O021 ALPHA ACER TENDL-2024 LIBRARY; T=0.K
Photon emission for (n,2np)

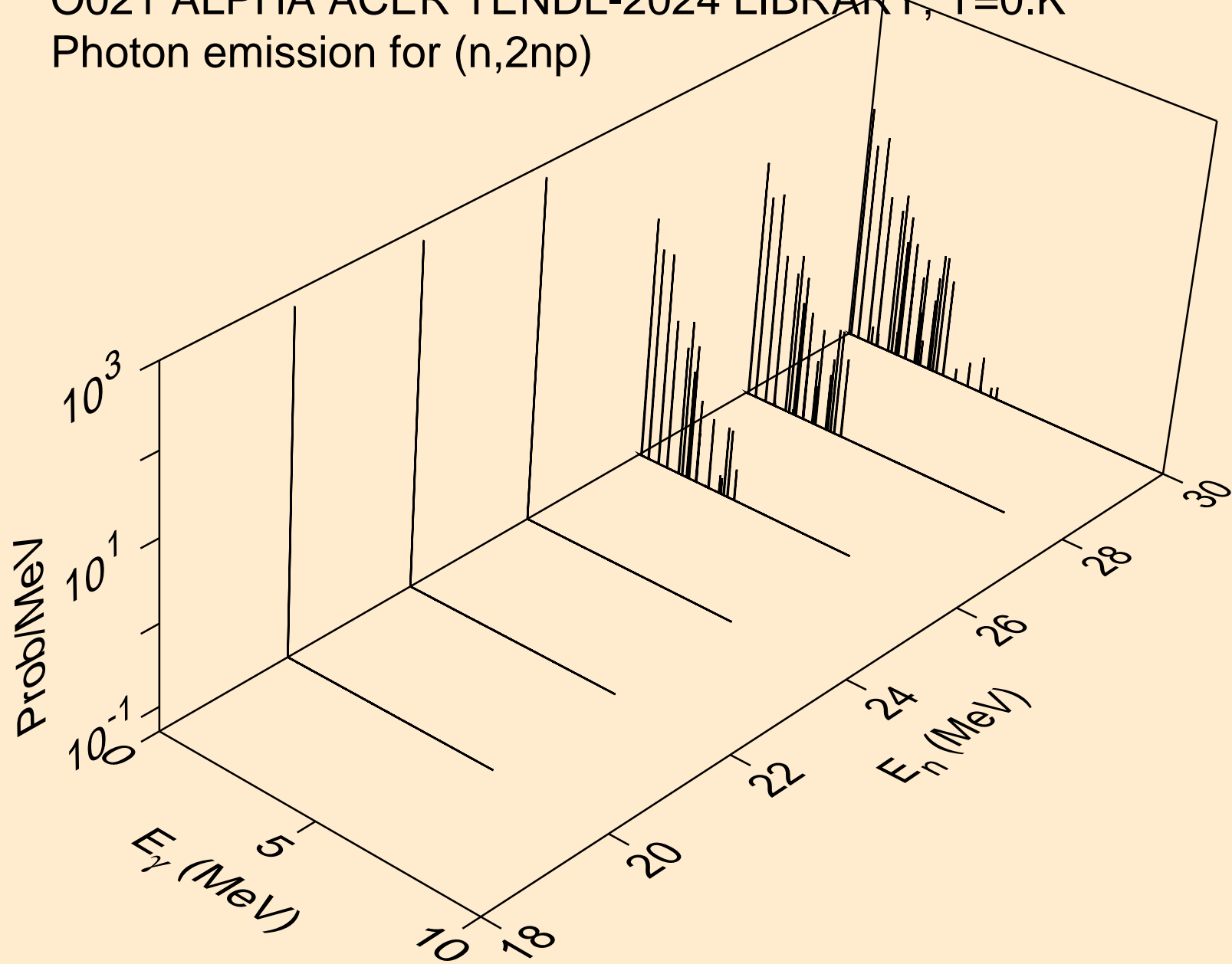

O021 ALPHA ACER TENDL-2024 LIBRARY; T=0.K
Photon emission for (n,3np)

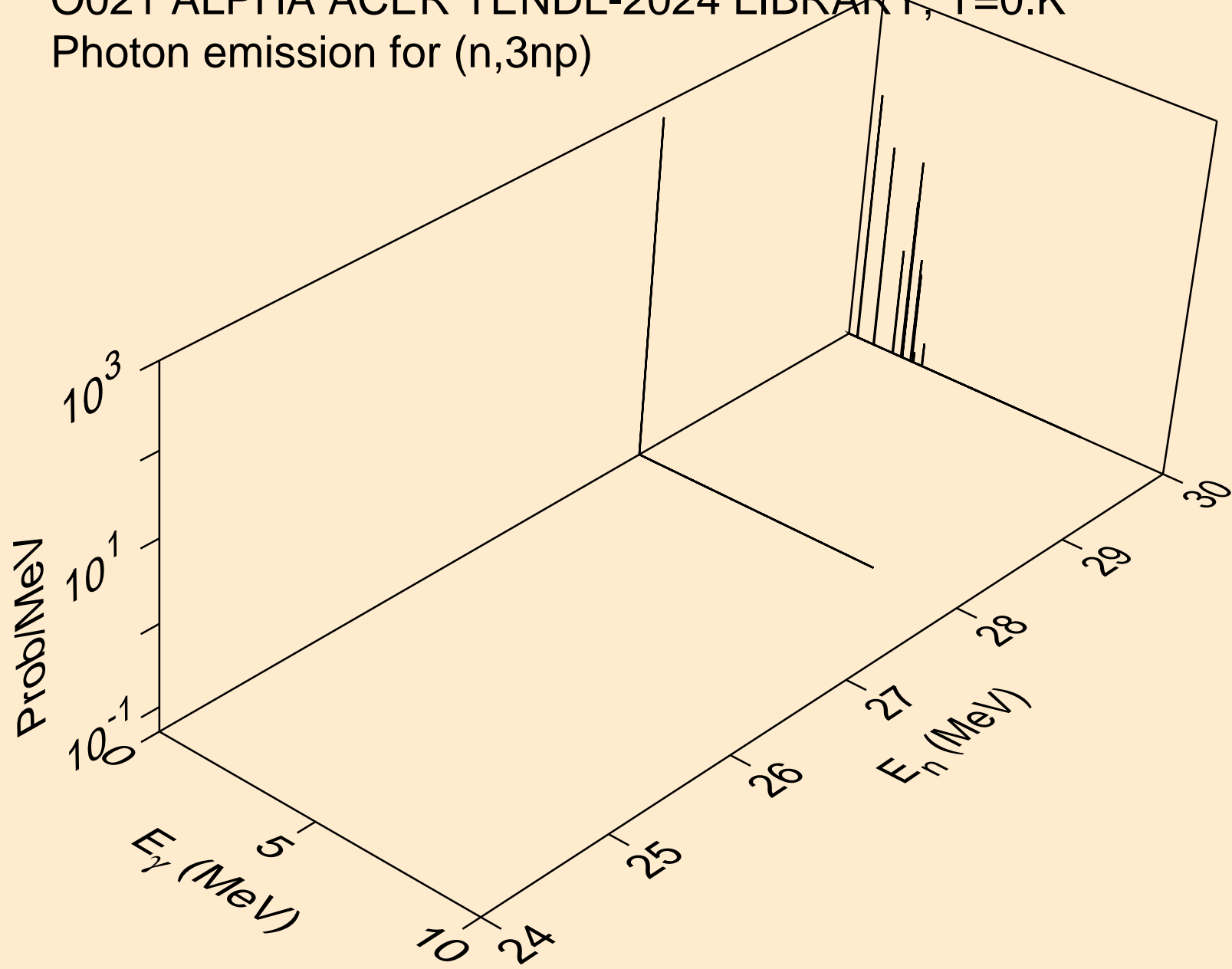

O021 ALPHA ACER TENDL-2024 LIBRARY; T=0.K
Photon emission for (n,n2p)

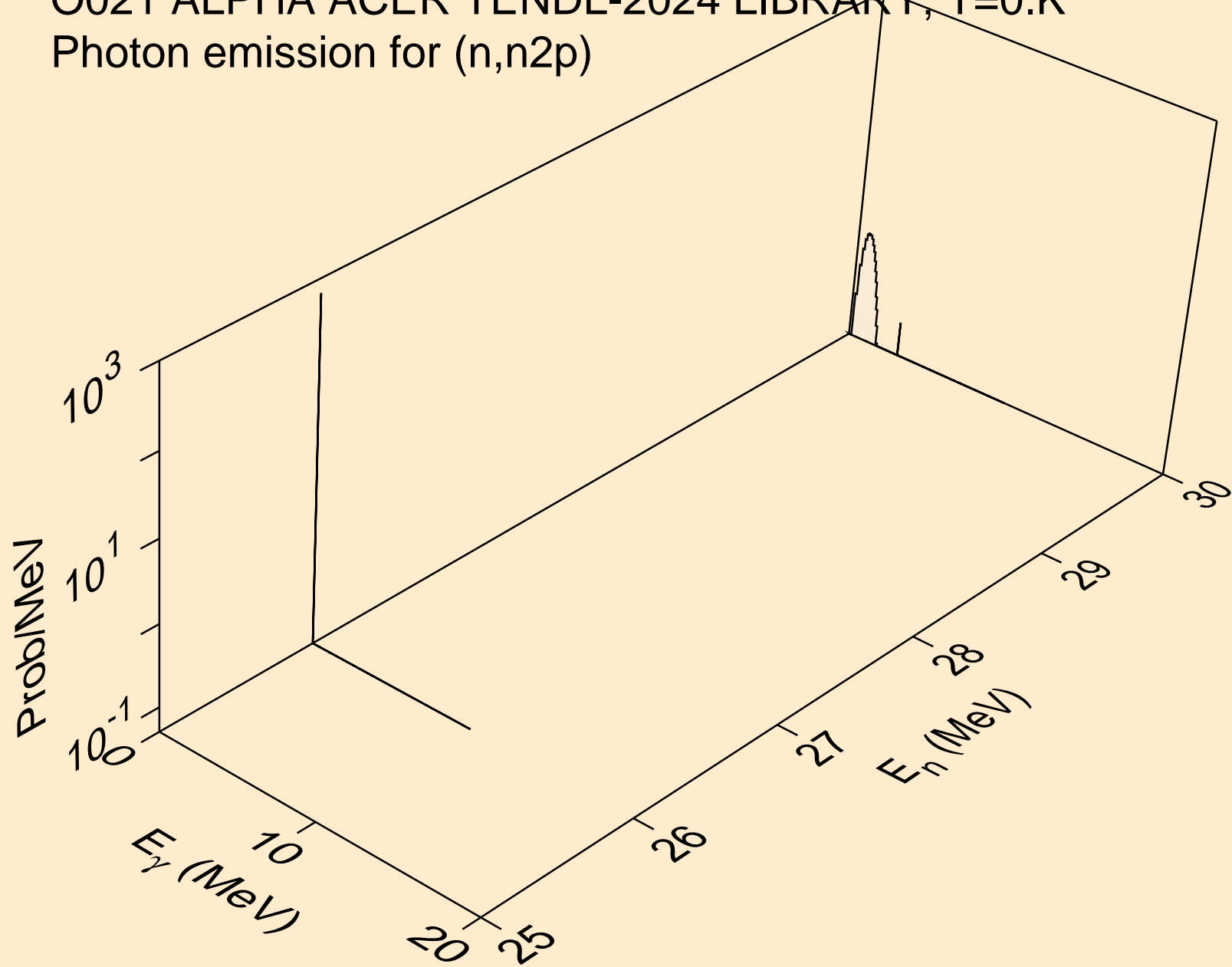

O021 ALPHA ACER TENDL-2024 LIBRARY; T=0.K
Photon emission for (n,gma)

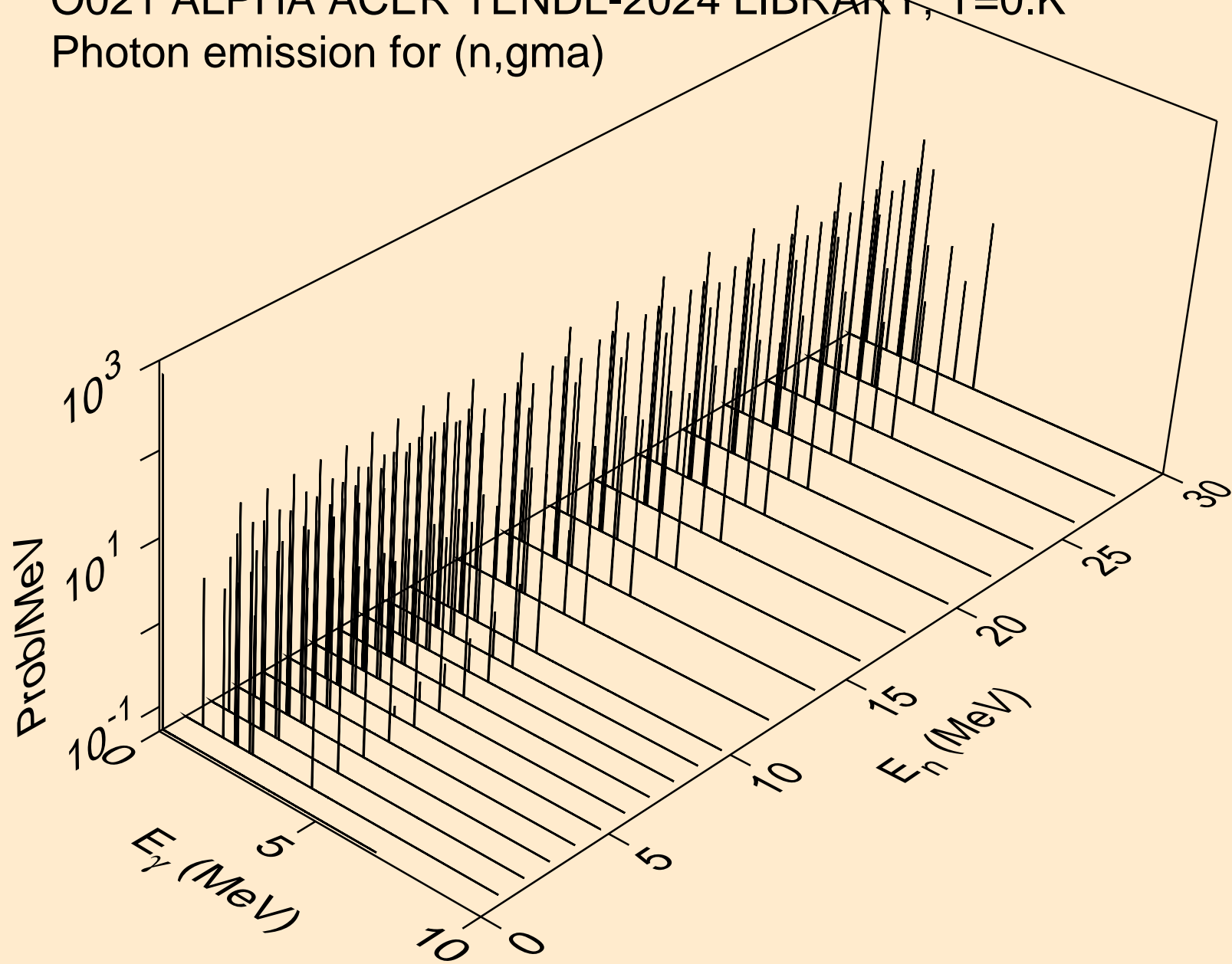

O021 ALPHA ACER TENDL-2024 LIBRARY; T=0.K
Photon emission for (n,p)

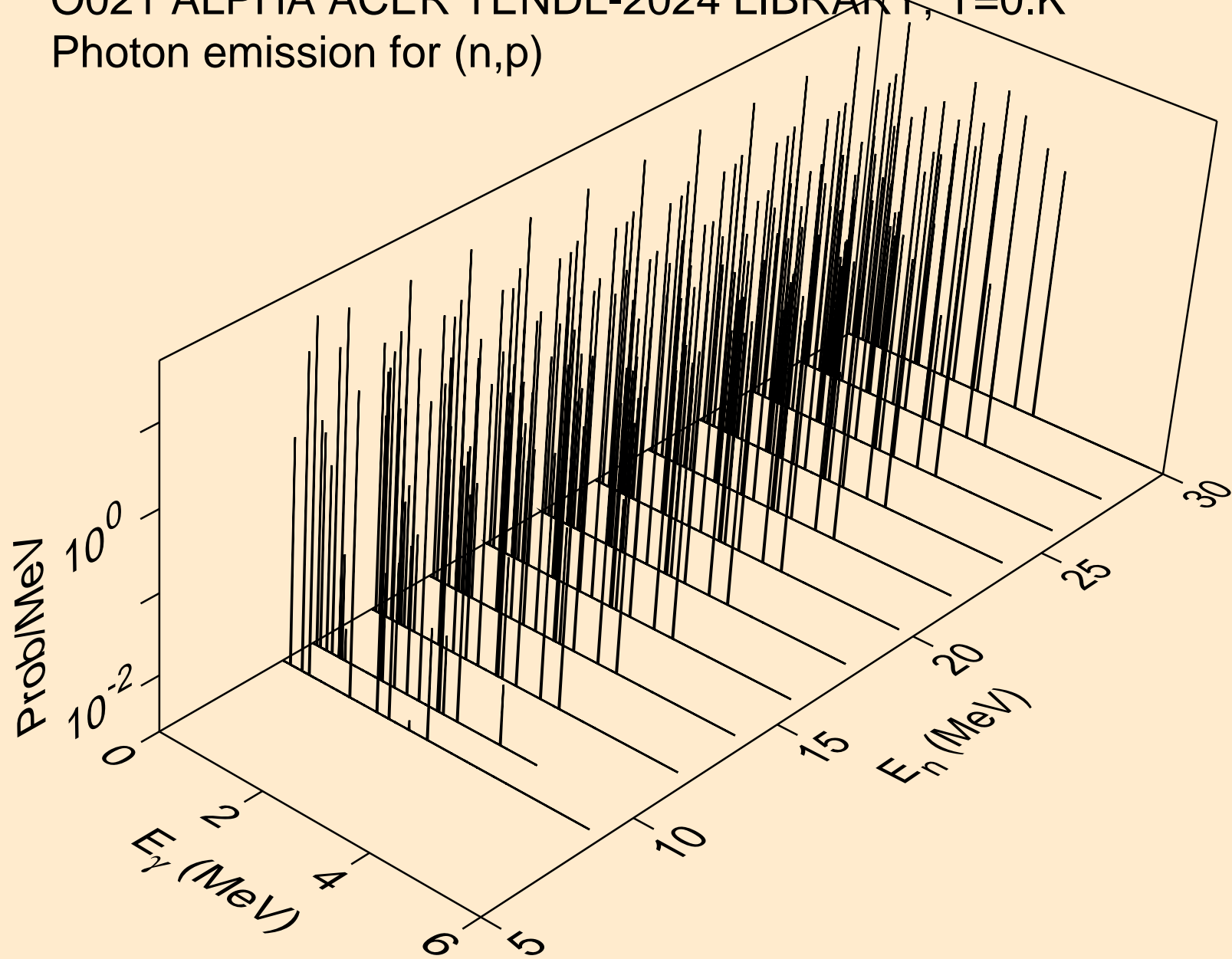

O021 ALPHA ACER TENDL-2024 LIBRARY; T=0.K
Photon emission for (n,d)

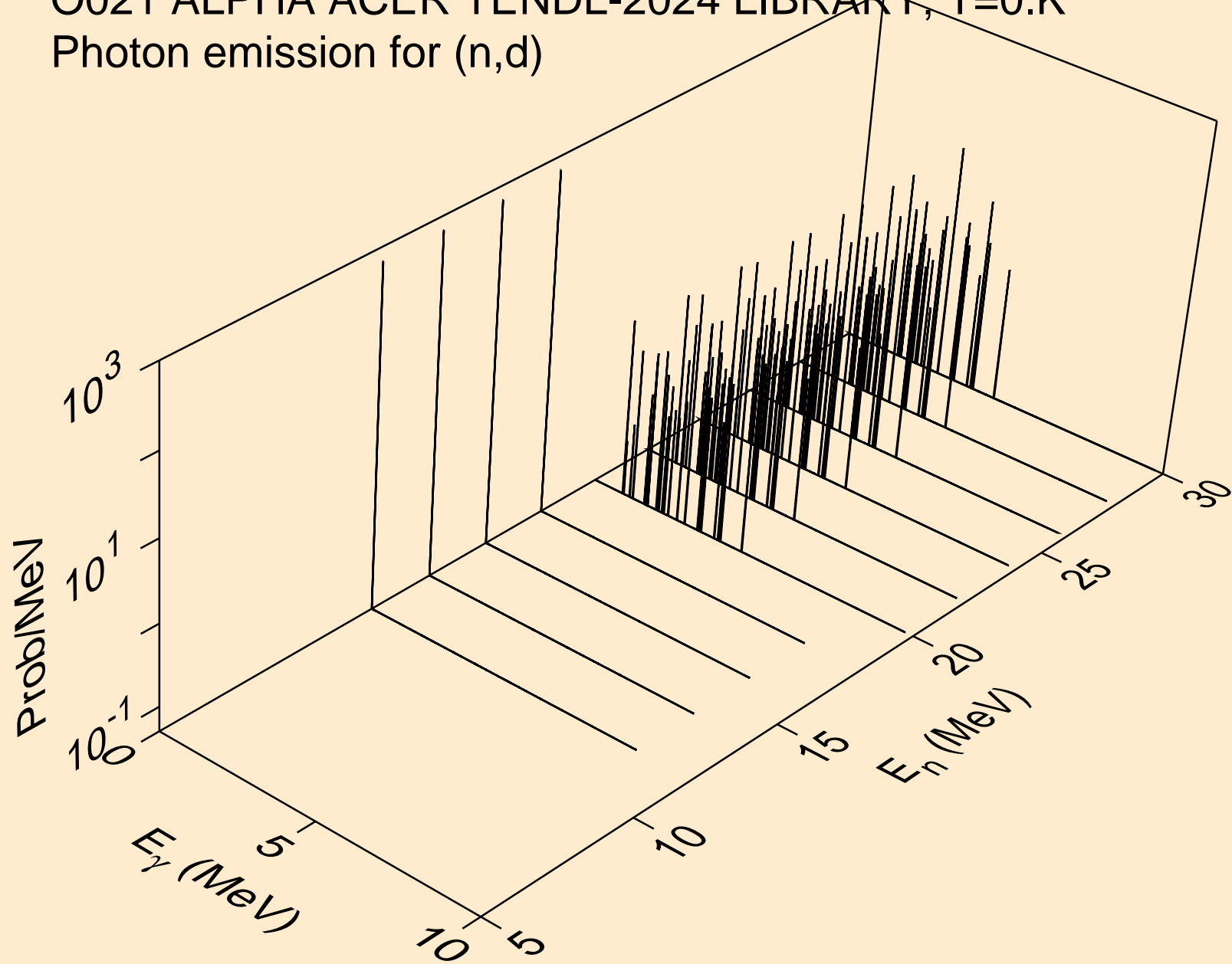

O021 ALPHA ACER TENDL-2024 LIBRARY; T=0.K
Photon emission for (n,t)

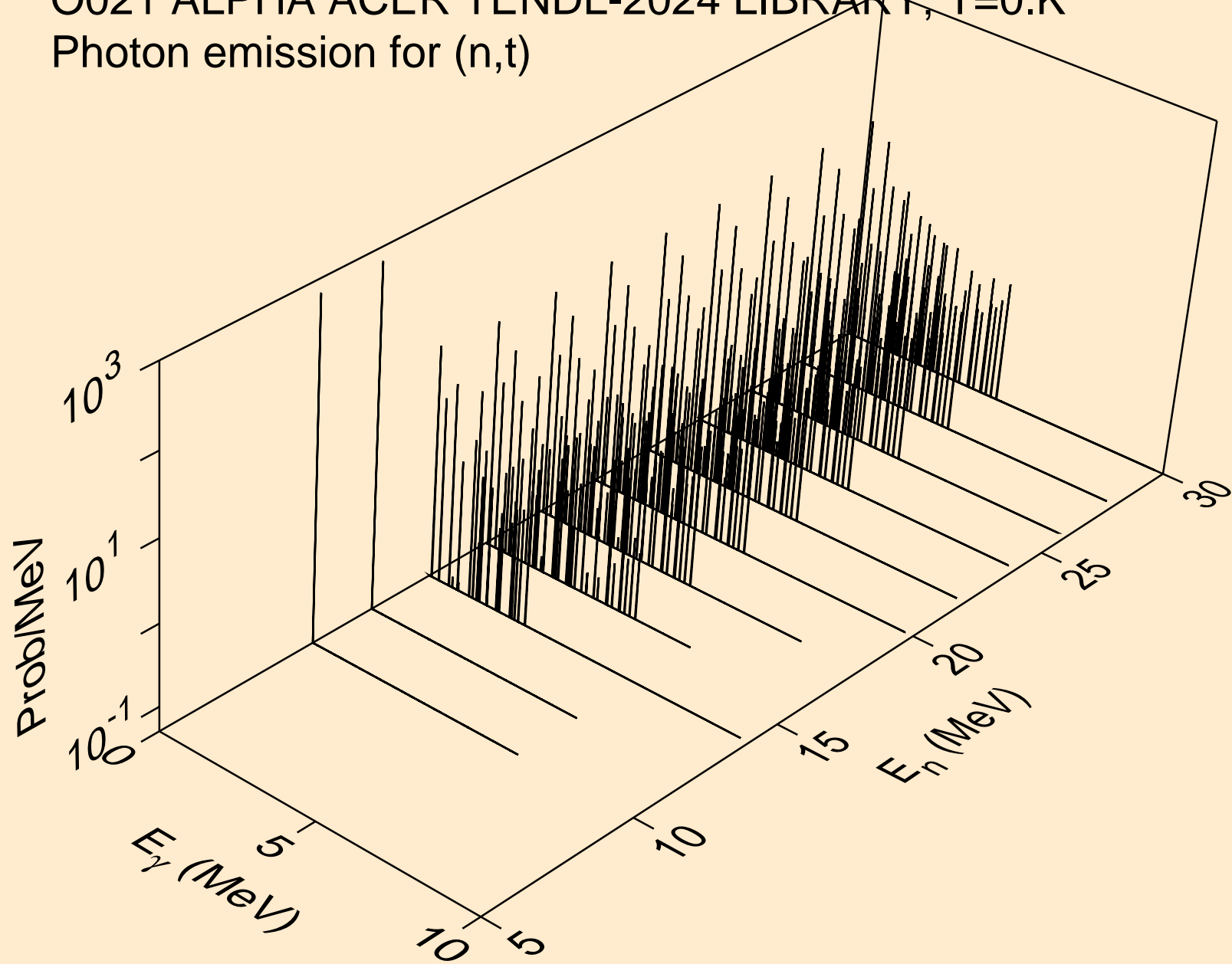

O021 ALPHA ACER TENDL-2024 LIBRARY; T=0.K
Photon emission for (n,he3)

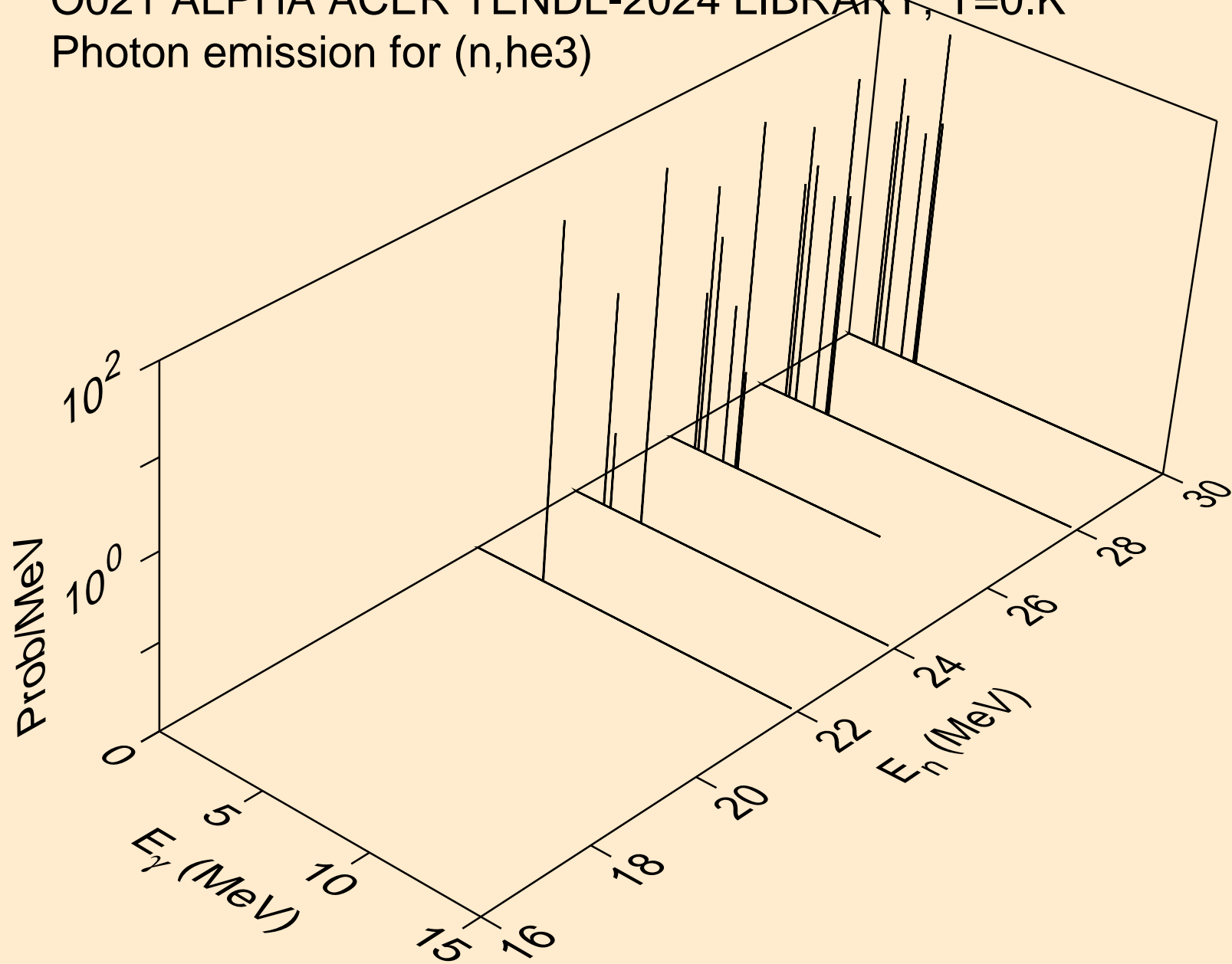

O021 ALPHA ACER TENDL-2024 LIBRARY; T=0.K
Photon emission for inelastic

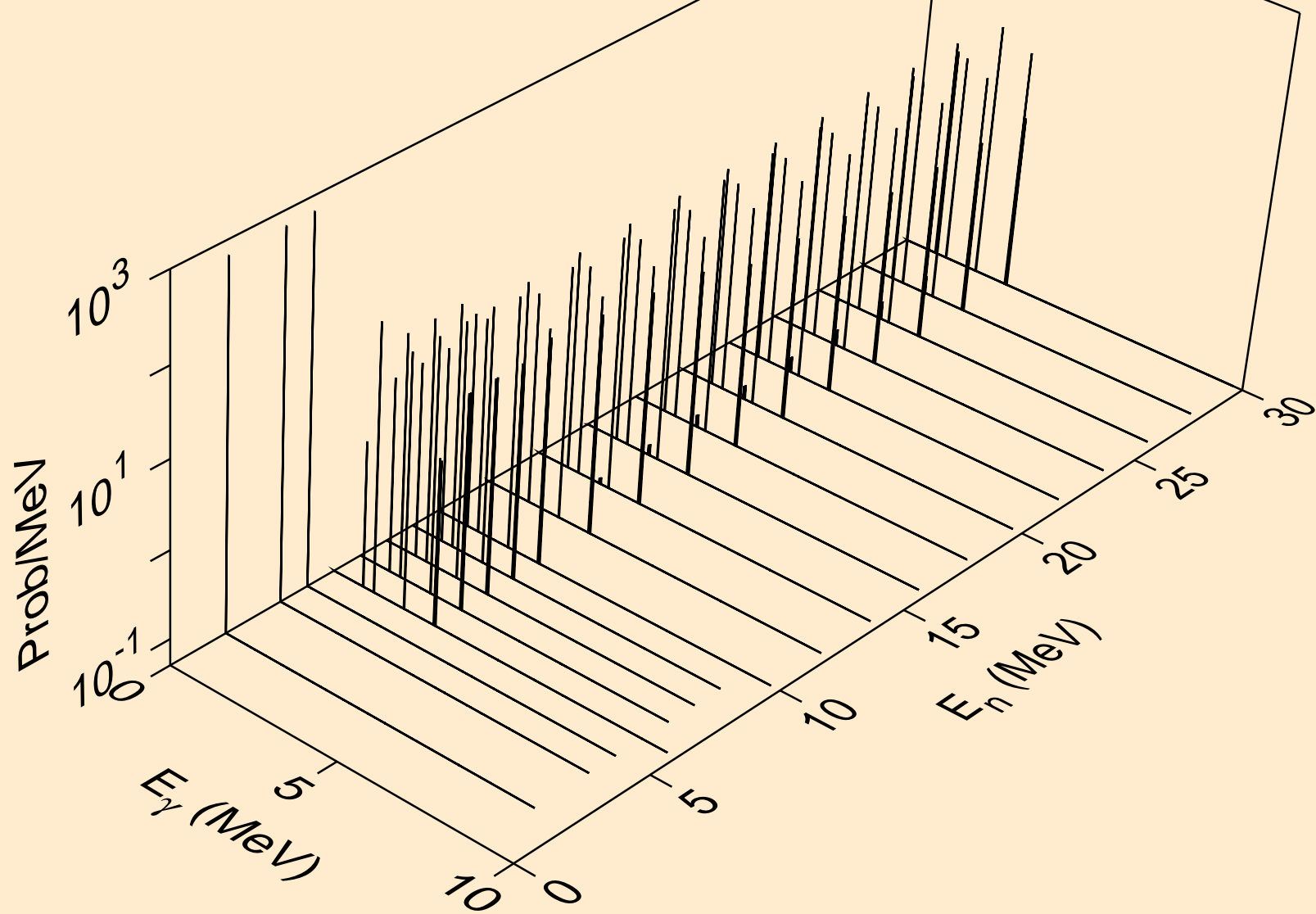

O021 ALPHA ACER TENDL-2024 LIBRARY; T=0.K
Photon emission for (n,2a)

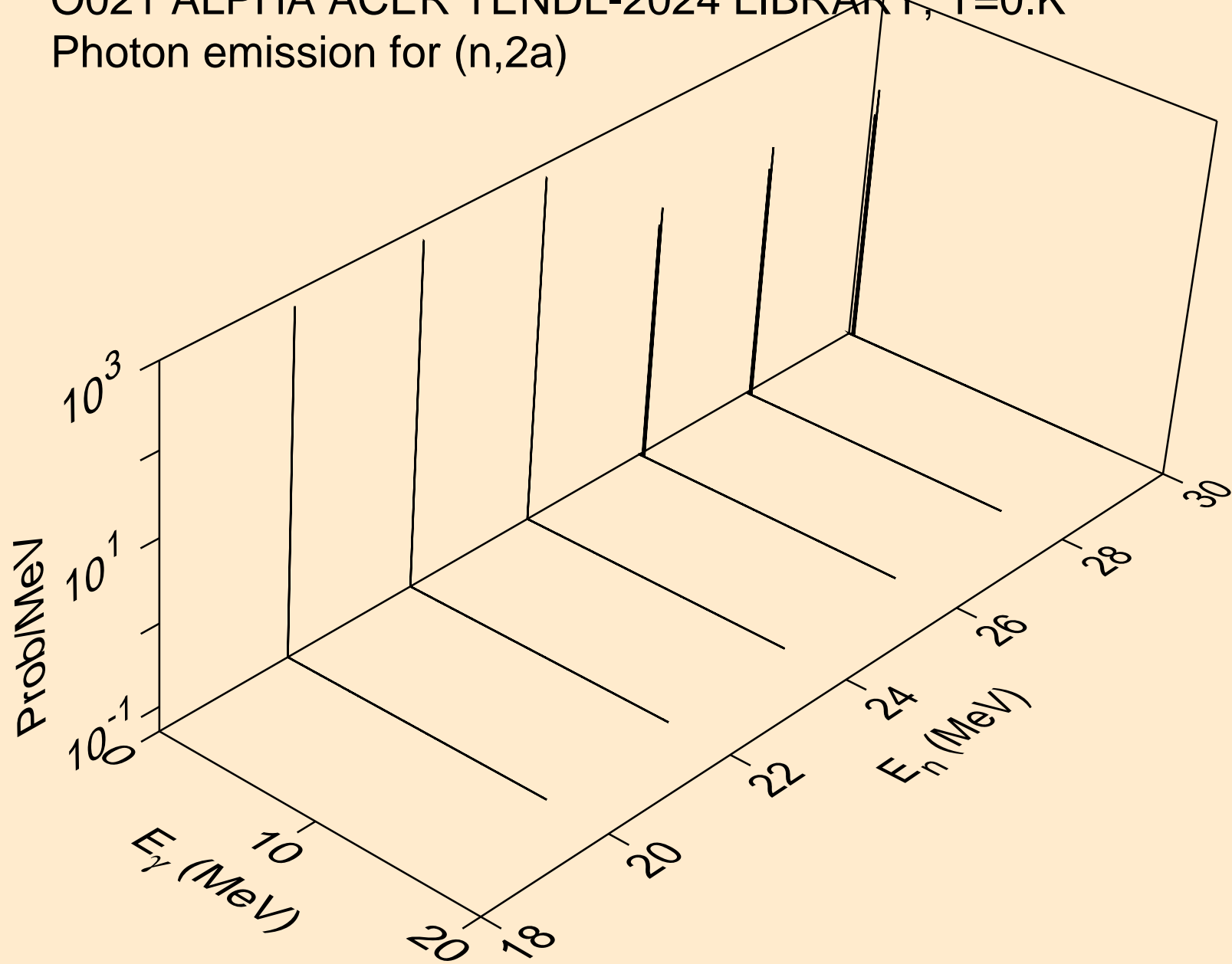

O021 ALPHA ACER TENDL-2024 LIBRARY; T=0.K
Photon emission for (n,2p)

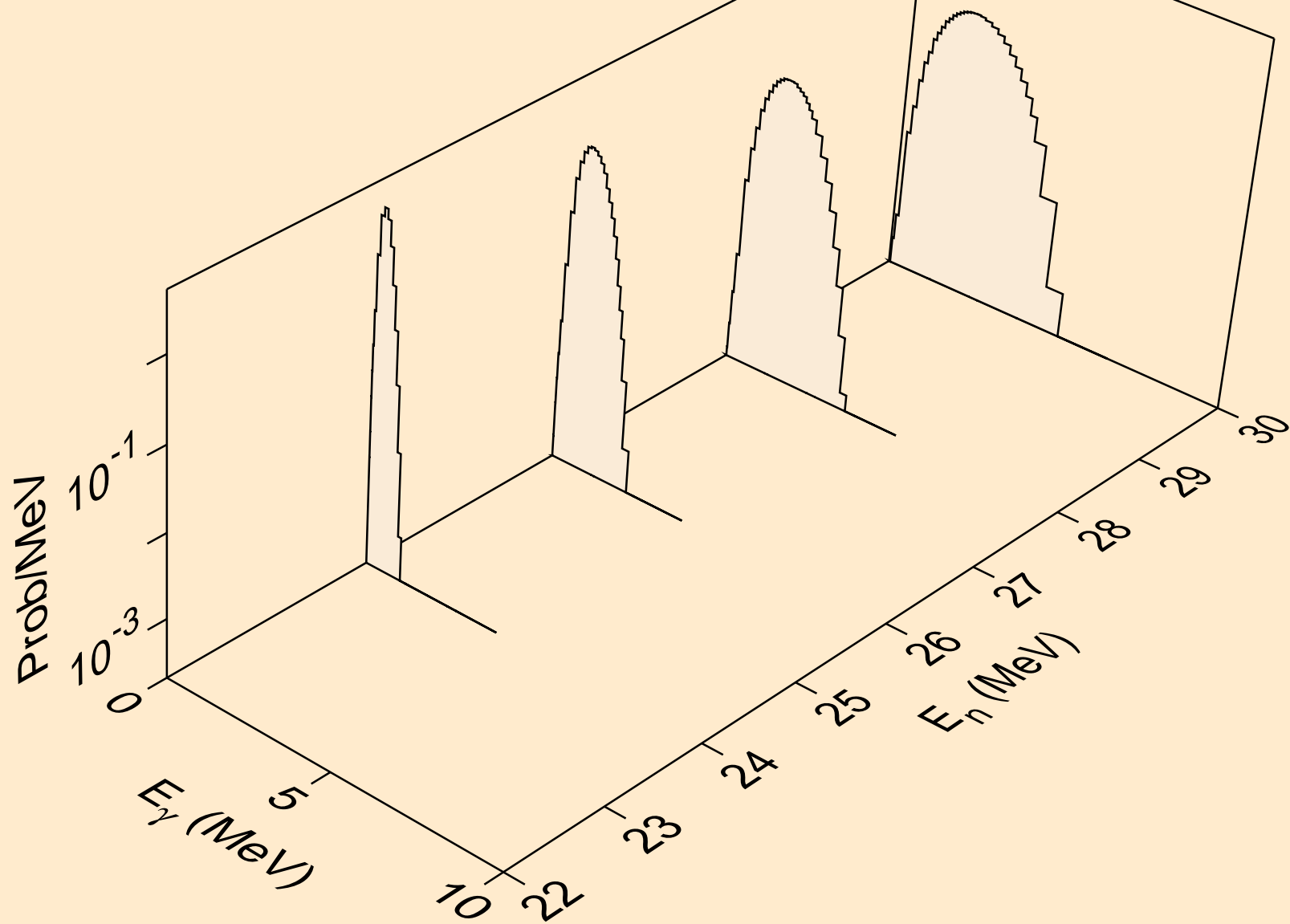

O021 ALPHA ACER TENDL-2024 LIBRARY; T=0.K
Photon emission for (n,pa)

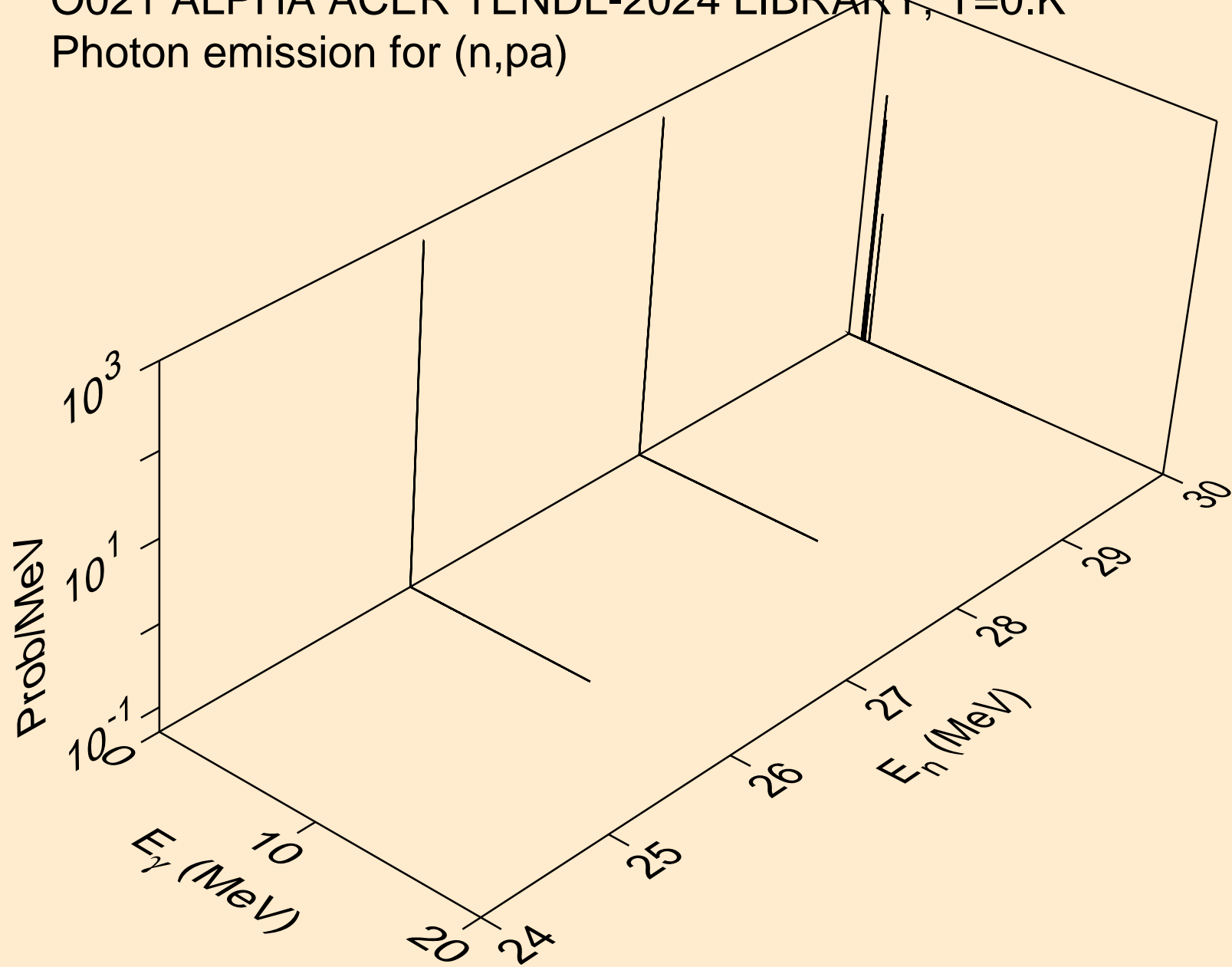

O021 ALPHA ACER TENDL-2024 LIBRARY; T=0.K
Photon emission for (n,pd)

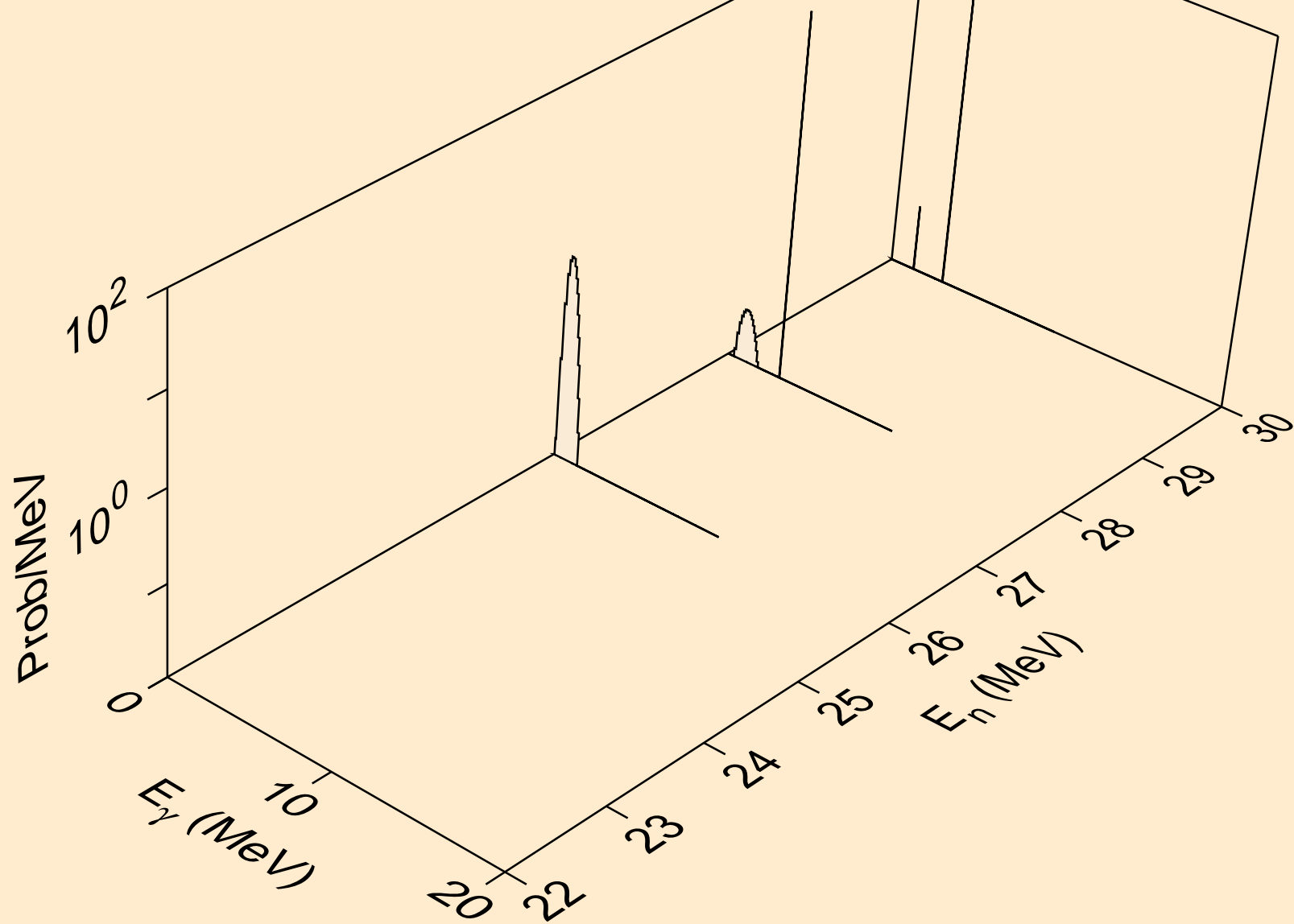

O021 ALPHA ACER TENDL-2024 LIBRARY; T=0.K
Photon emission for (n,pt)

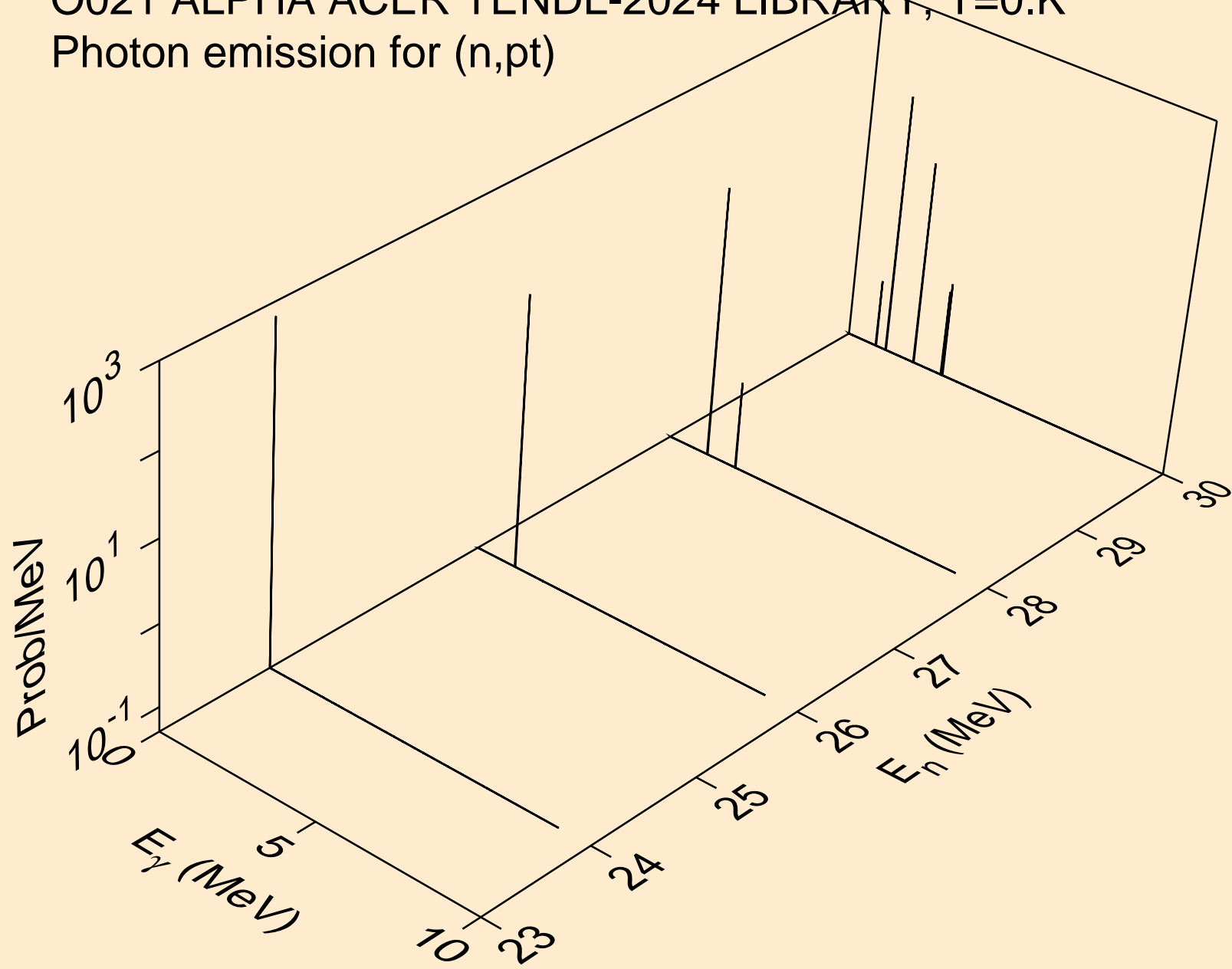

O021 ALPHA ACER TENDL-2024 LIBRARY; T=0.K
Photon emission for (n,da)

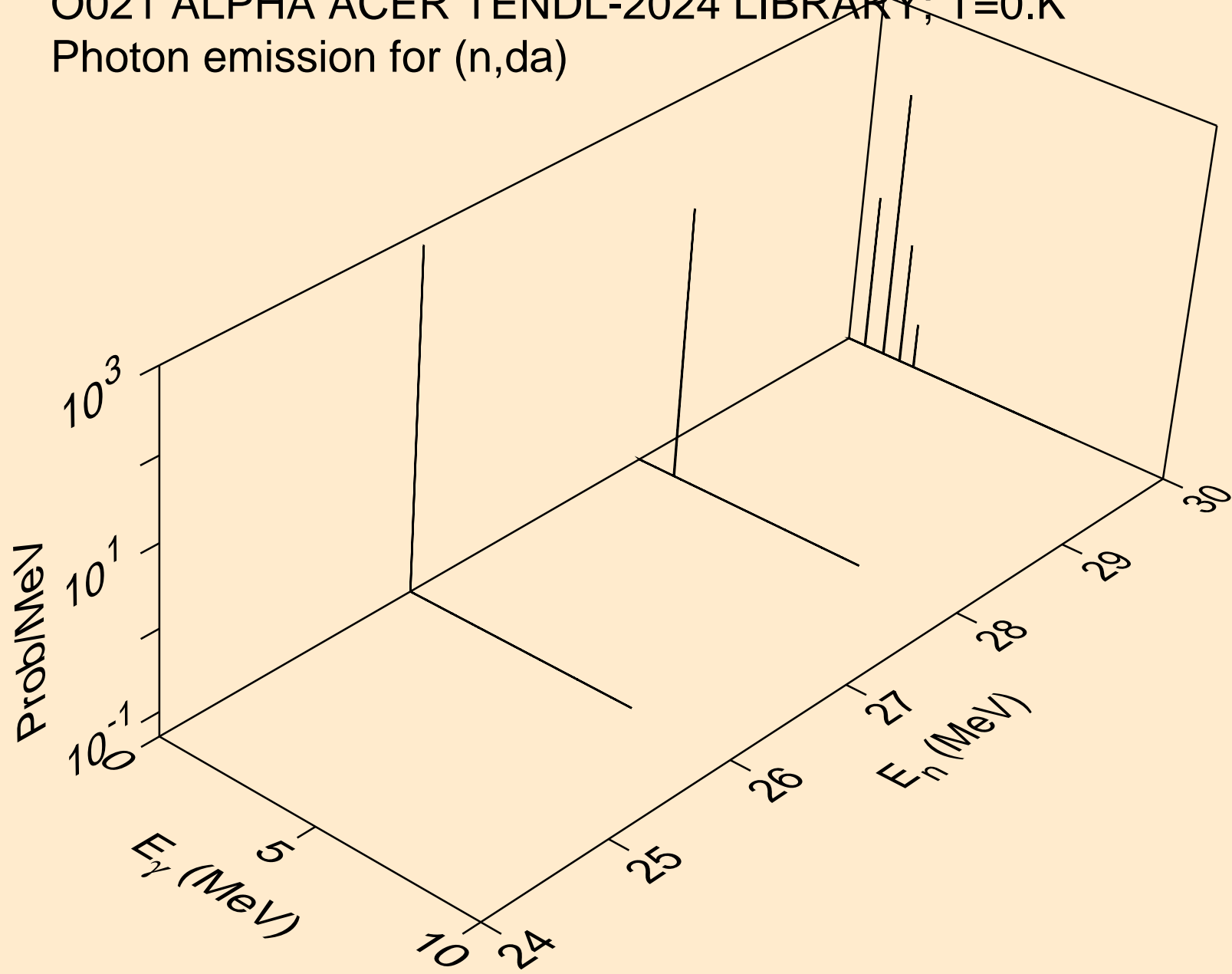

O021 ALPHA ACER TENDL-2024 LIBRARY; T=0.K
Particle heating contributions

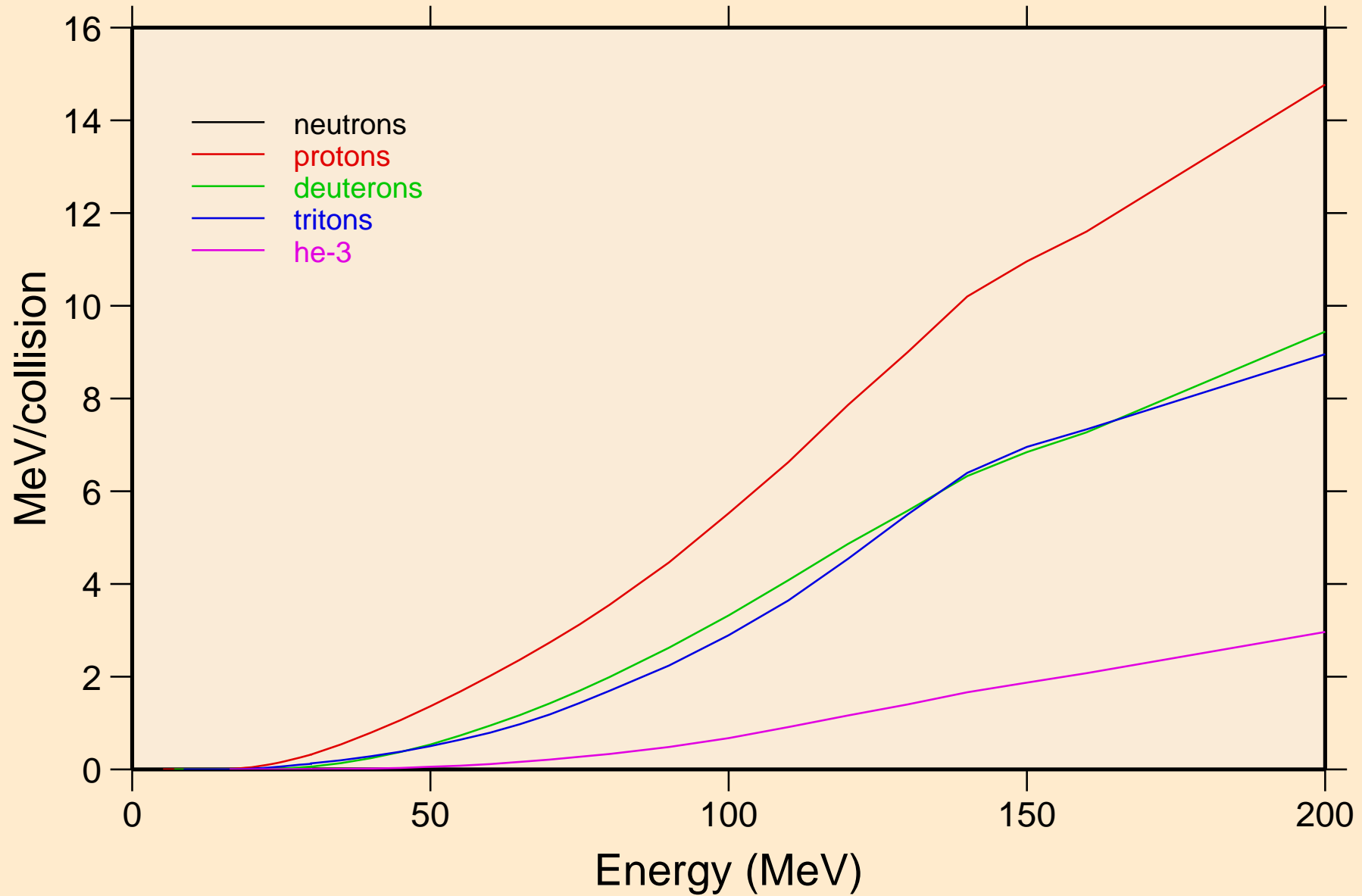

O021 ALPHA ACER TENDL-2024 LIBRARY; T=0.K
Recoil Heating

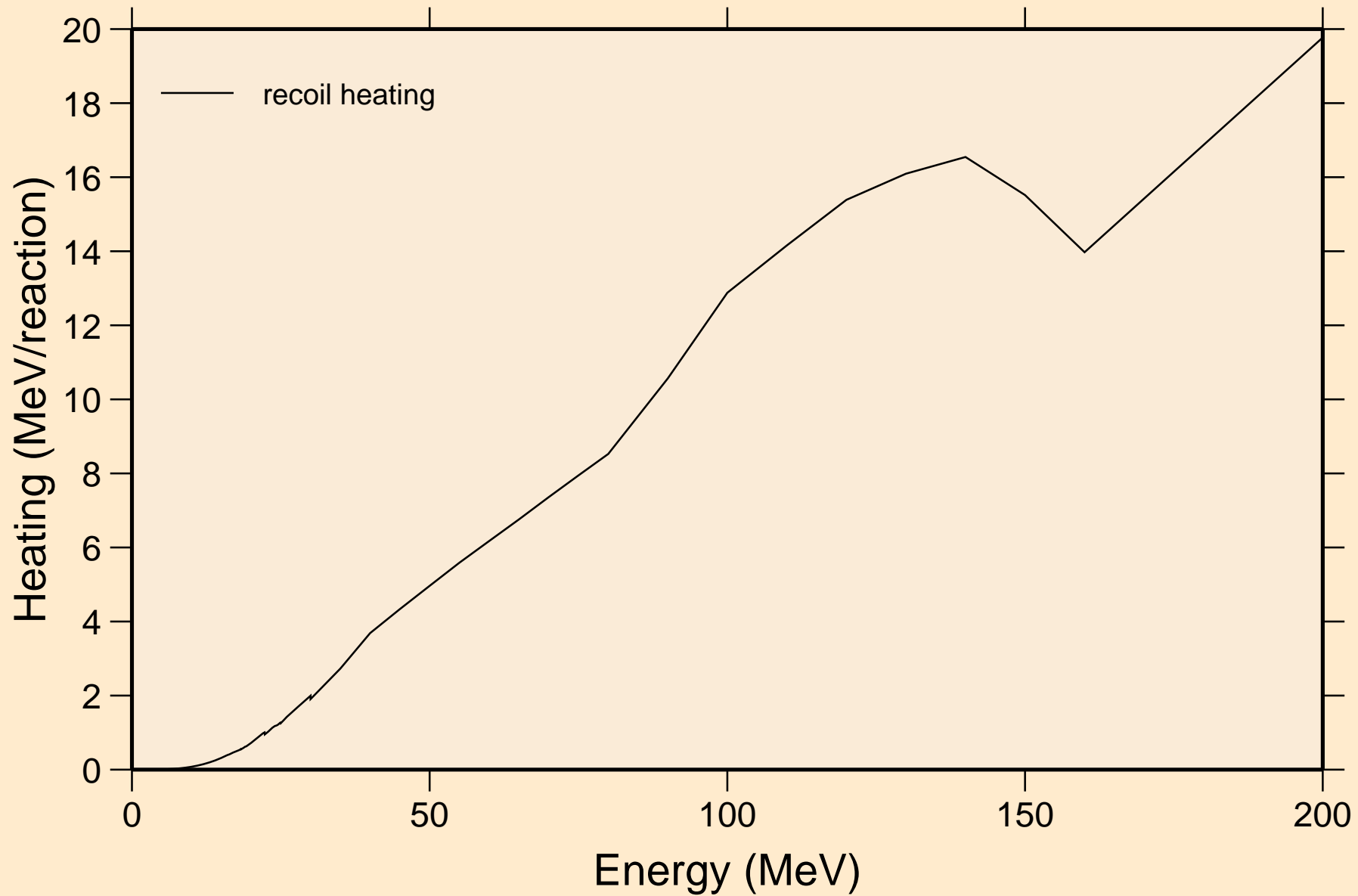

O021 ALPHA ACER TENDL-2024 LIBRARY; T=0.K
Particle production cross sections

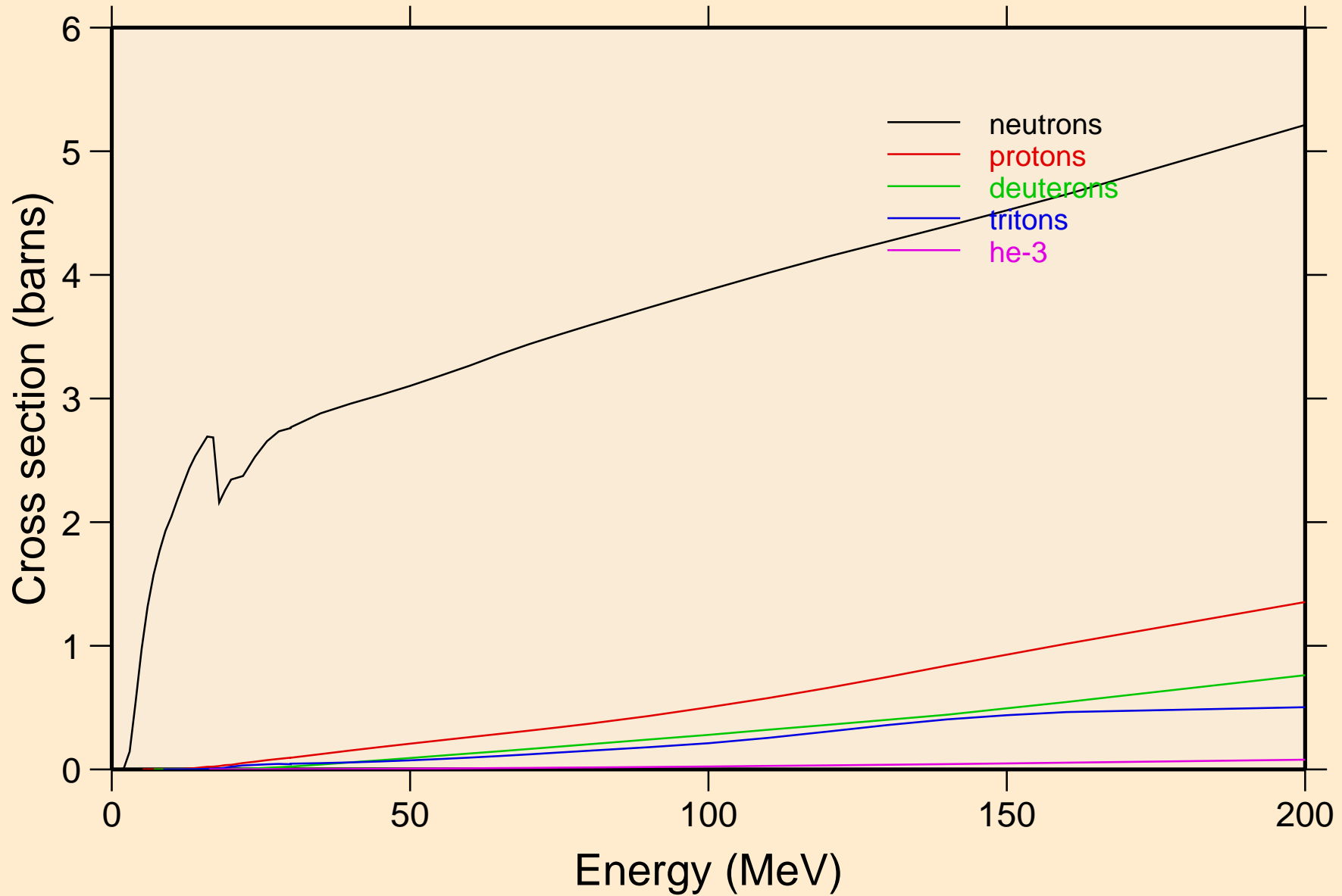

O021 ALPHA ACER TENDL-2024 LIBRARY; T=0.K
neutrons from (a,n)

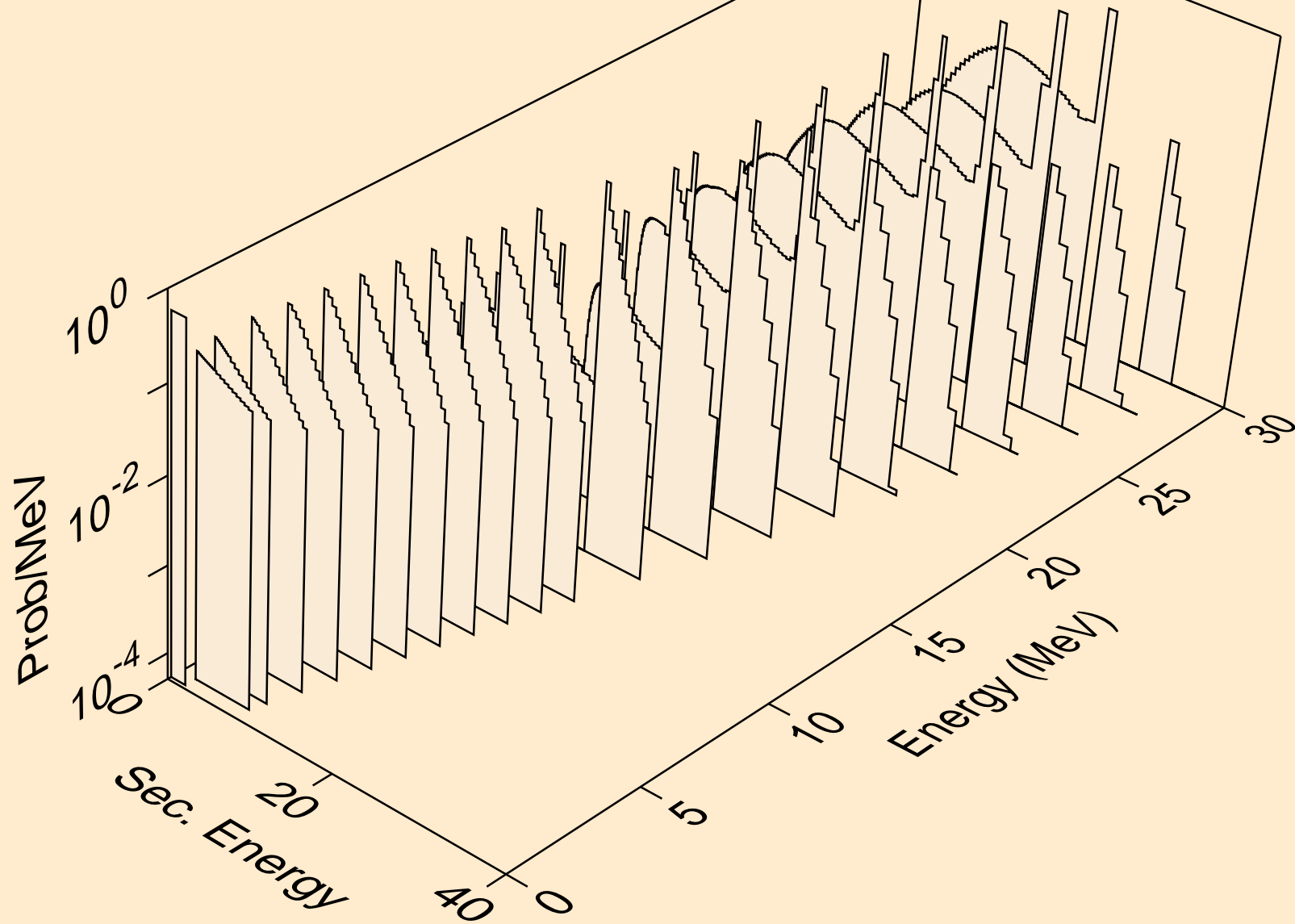

O021 ALPHA ACER TENDL-2024 LIBRARY; T=0.K
neutrons from (a,x)

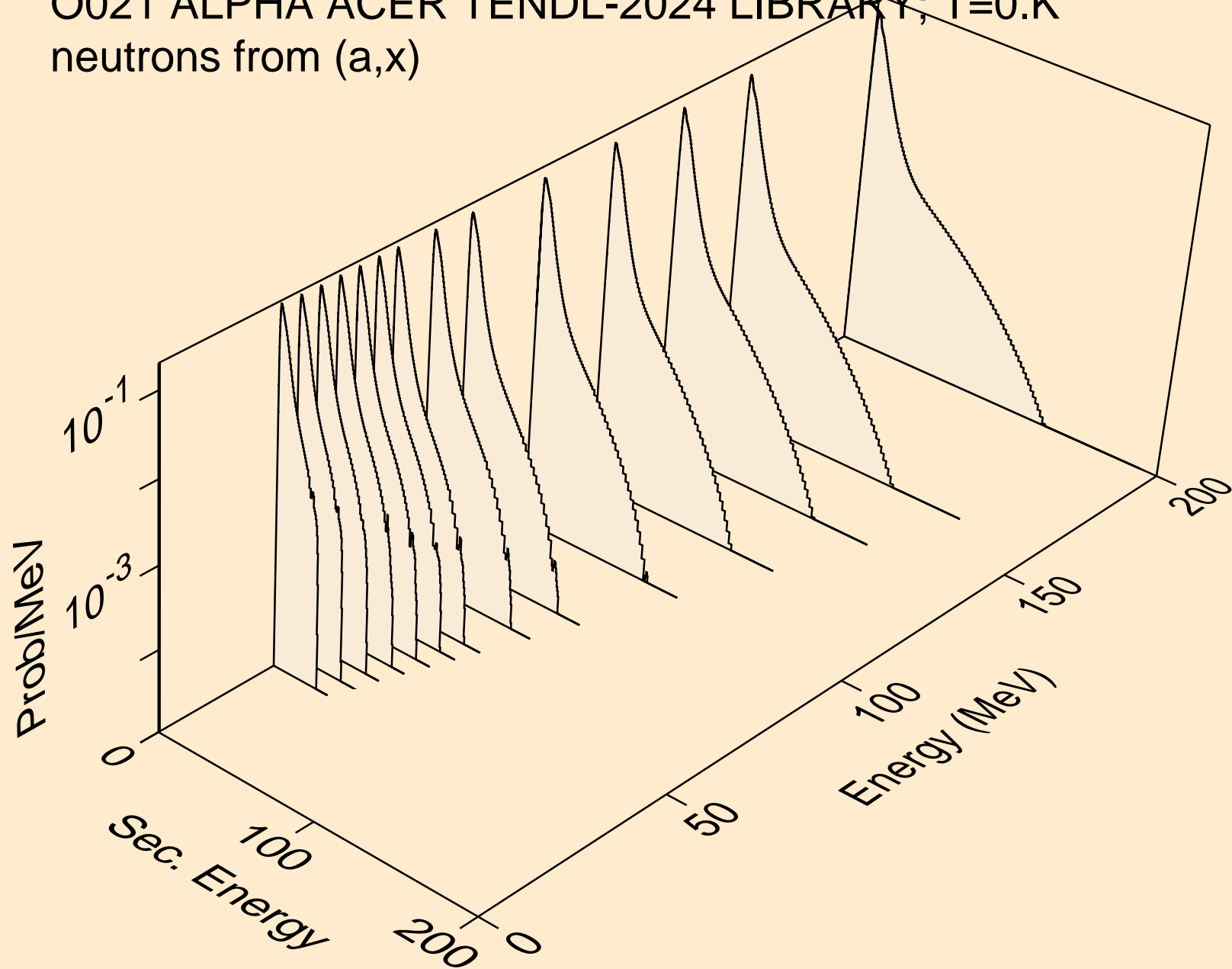

O021 ALPHA ACER TENDL-2024 LIBRARY; T=0.K
neutrons from (a,2nd)

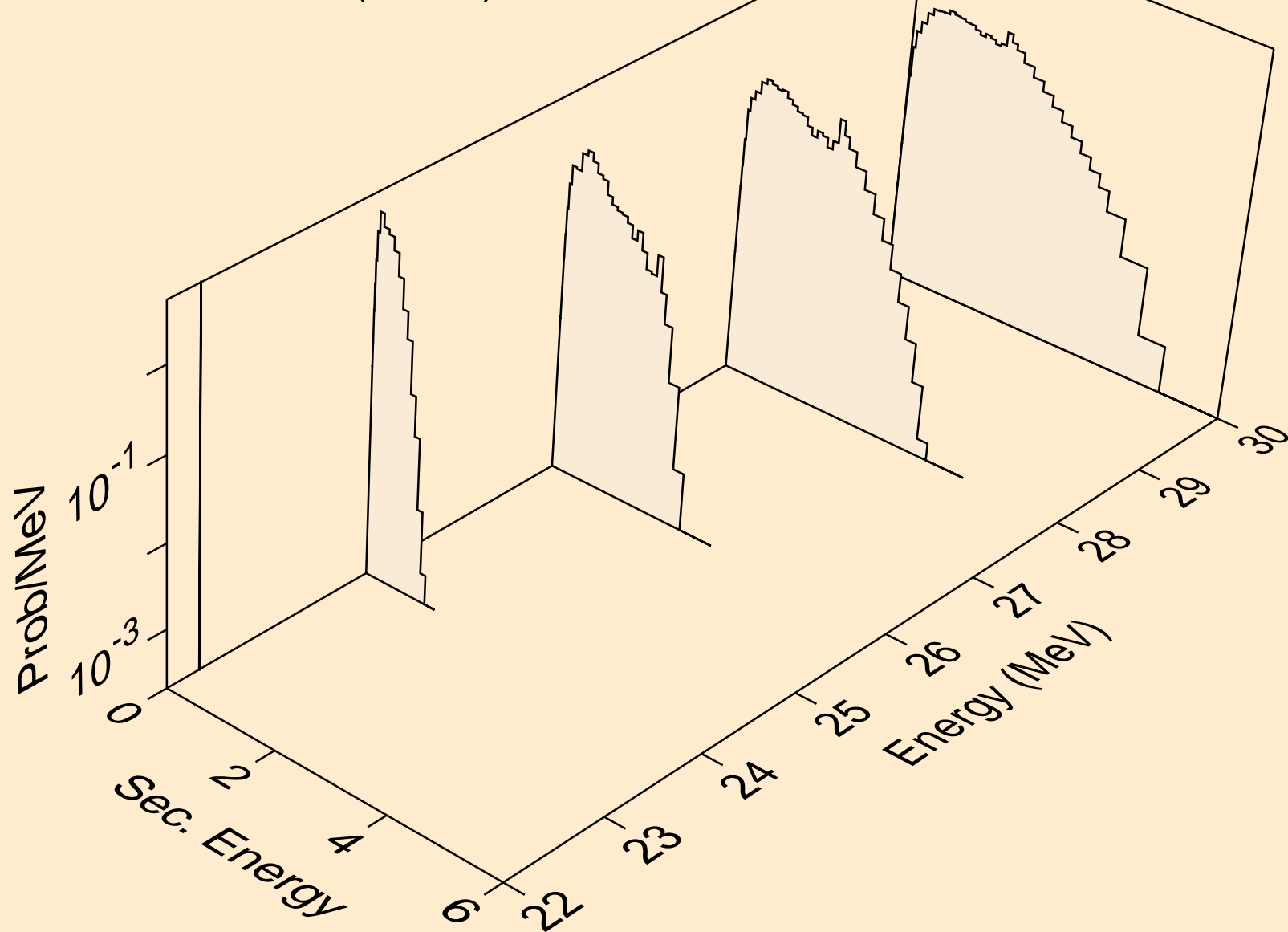

O021 ALPHA ACER TENDL-2024 LIBRARY; T=0.K
neutrons from (a,2n)

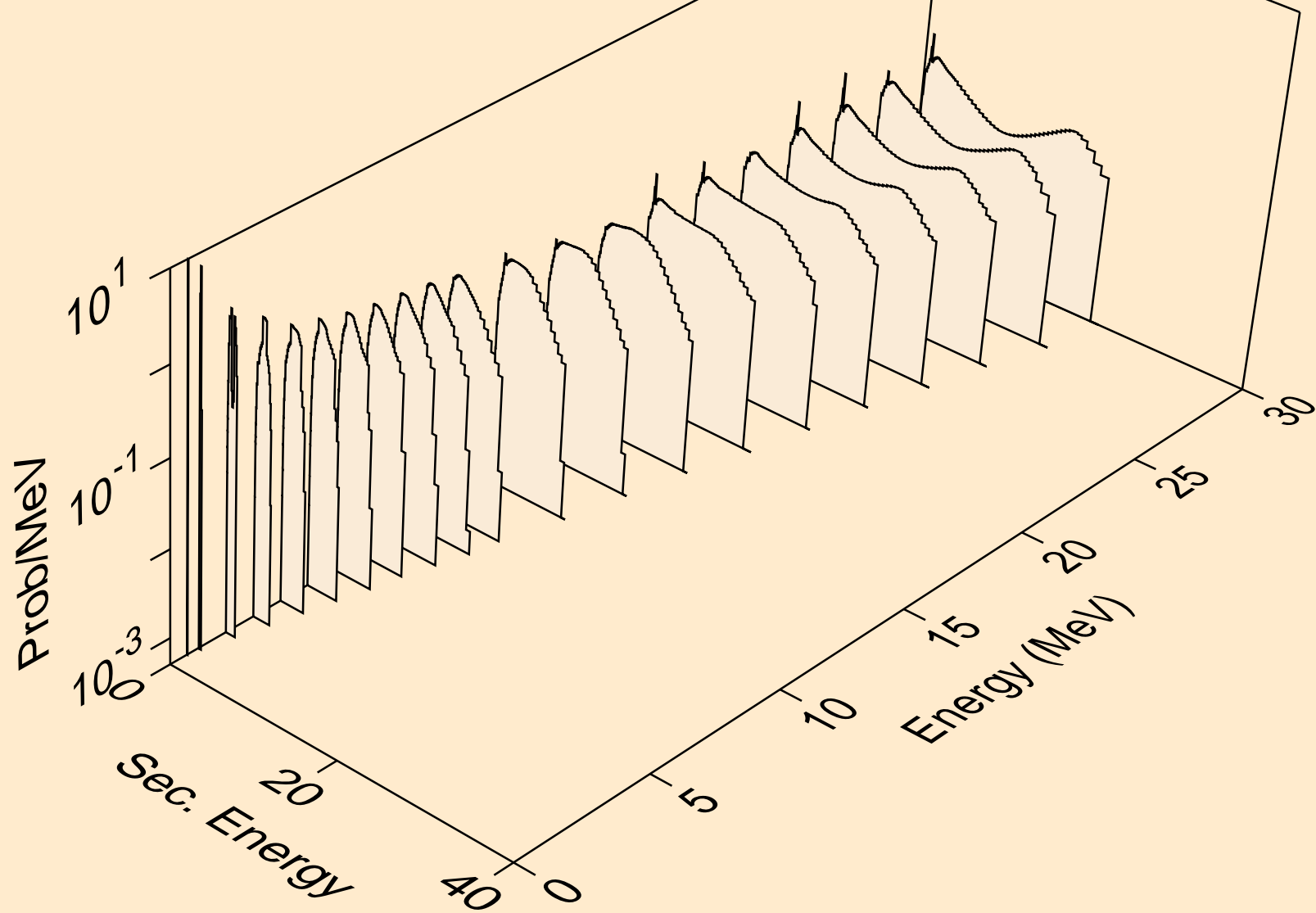

O021 ALPHA ACER TENDL-2024 LIBRARY; T=0.K
neutrons from (a,3n)

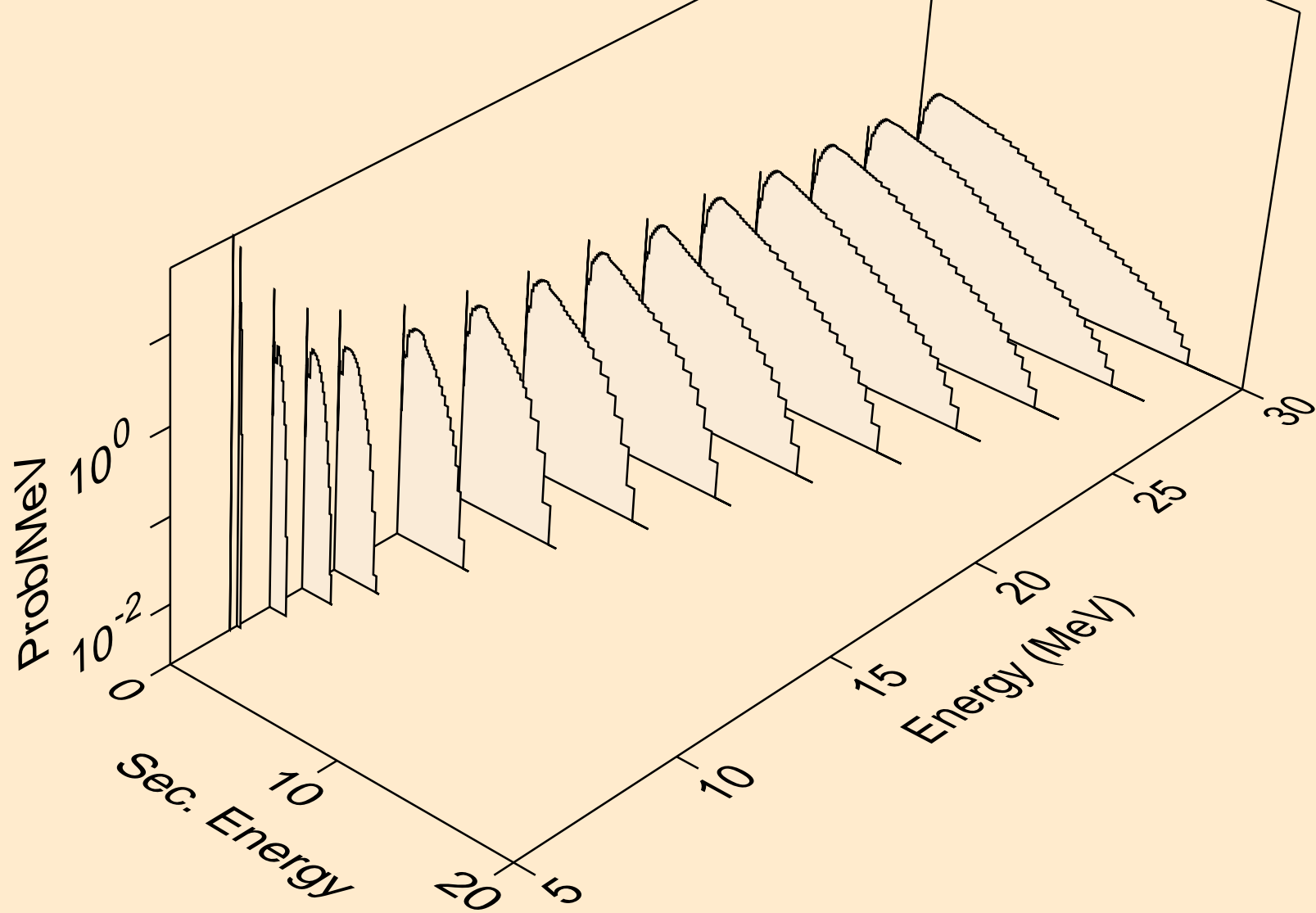

O021 ALPHA ACER TENDL-2024 LIBRARY; T=0.K
neutrons from (a,n*)a

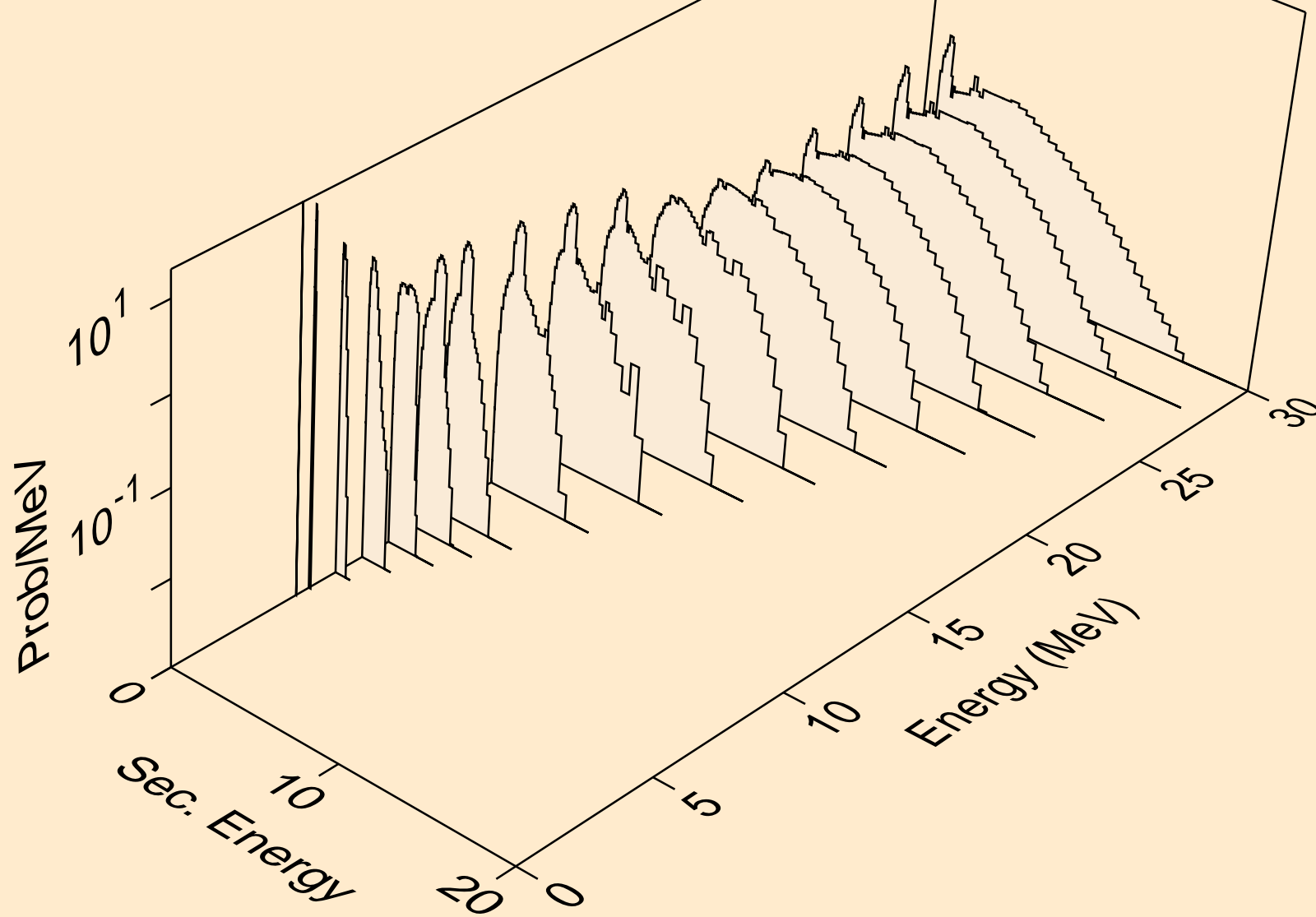

O021 ALPHA ACER TENDL-2024 LIBRARY; T=0.K
neutrons from (a,2n)a

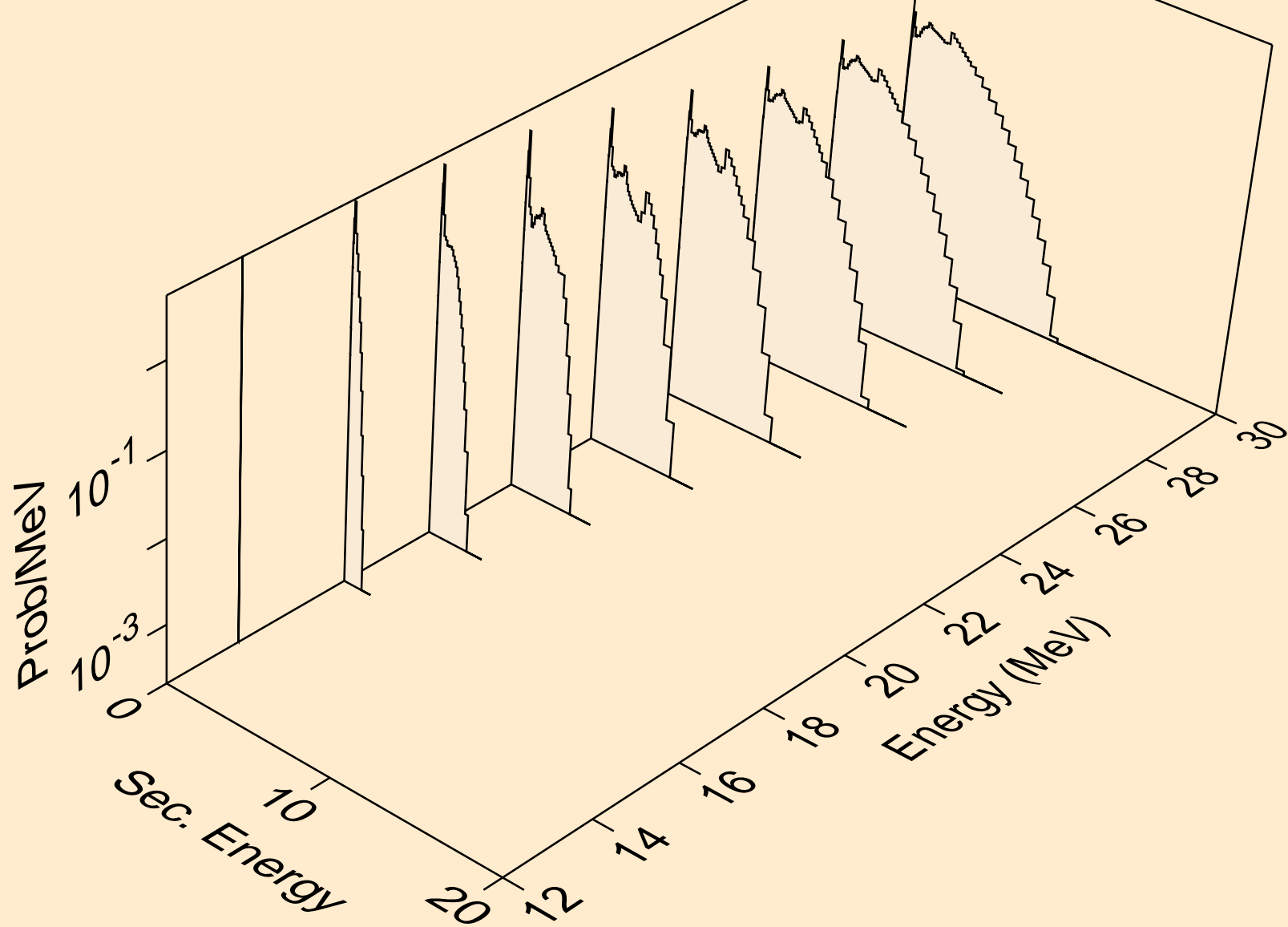

O021 ALPHA ACER TENDL-2024 LIBRARY; T=0.K
neutrons from (a,3n)a

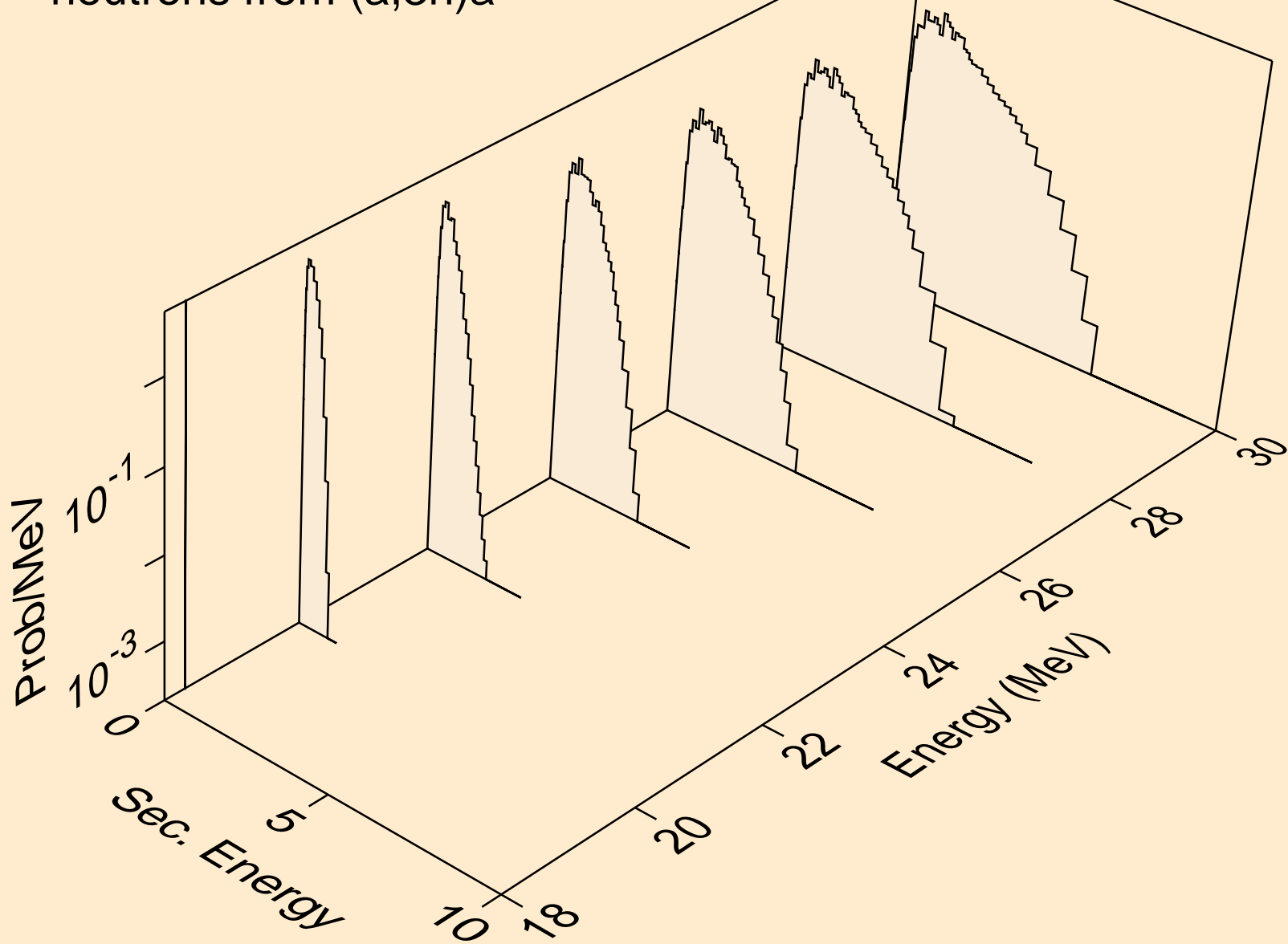

O021 ALPHA ACER TENDL-2024 LIBRARY; T=0.K
neutrons from (a,n*)p

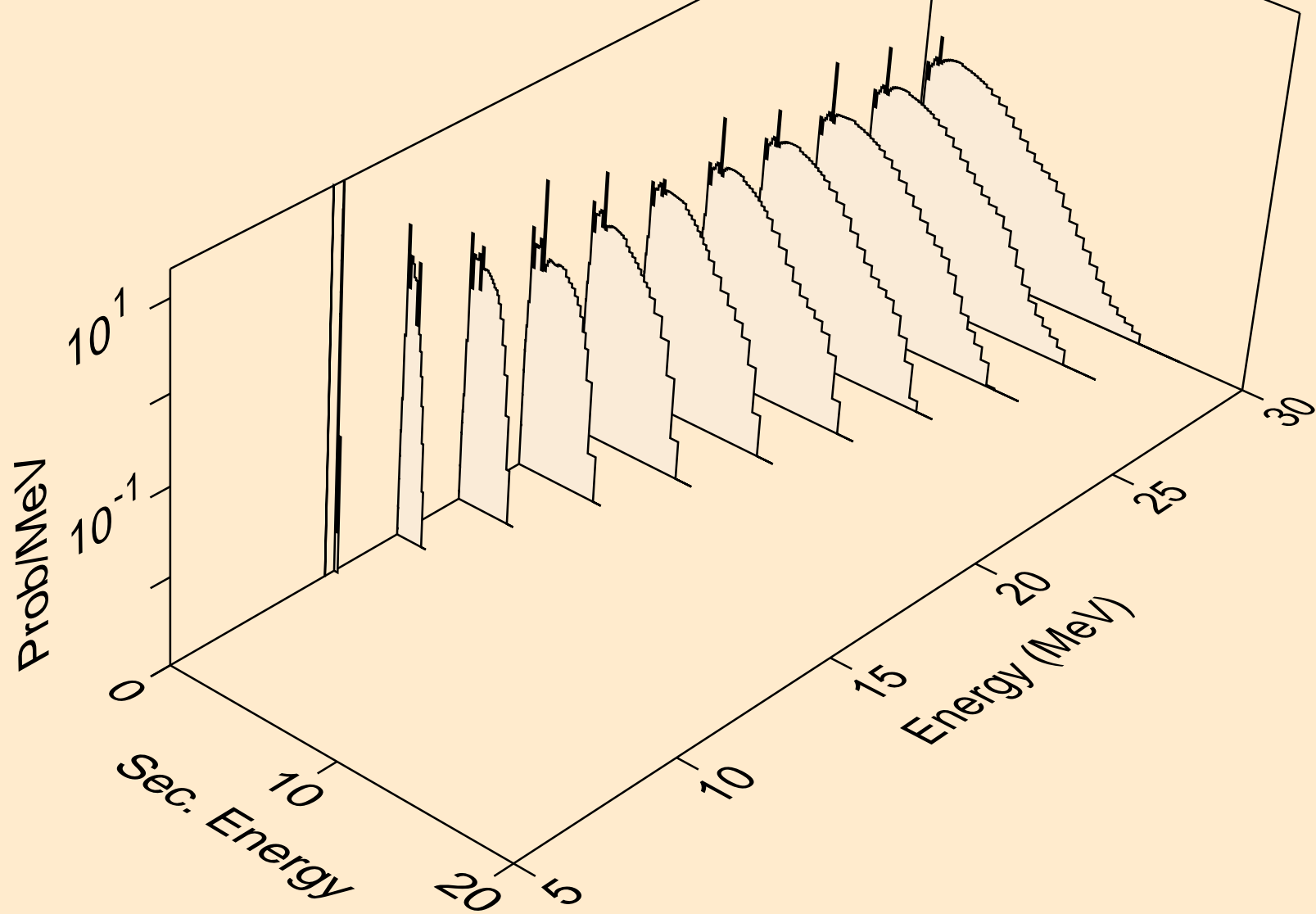

O021 ALPHA ACER TENDL-2024 LIBRARY; T=0.K
neutrons from (a,n*)2a

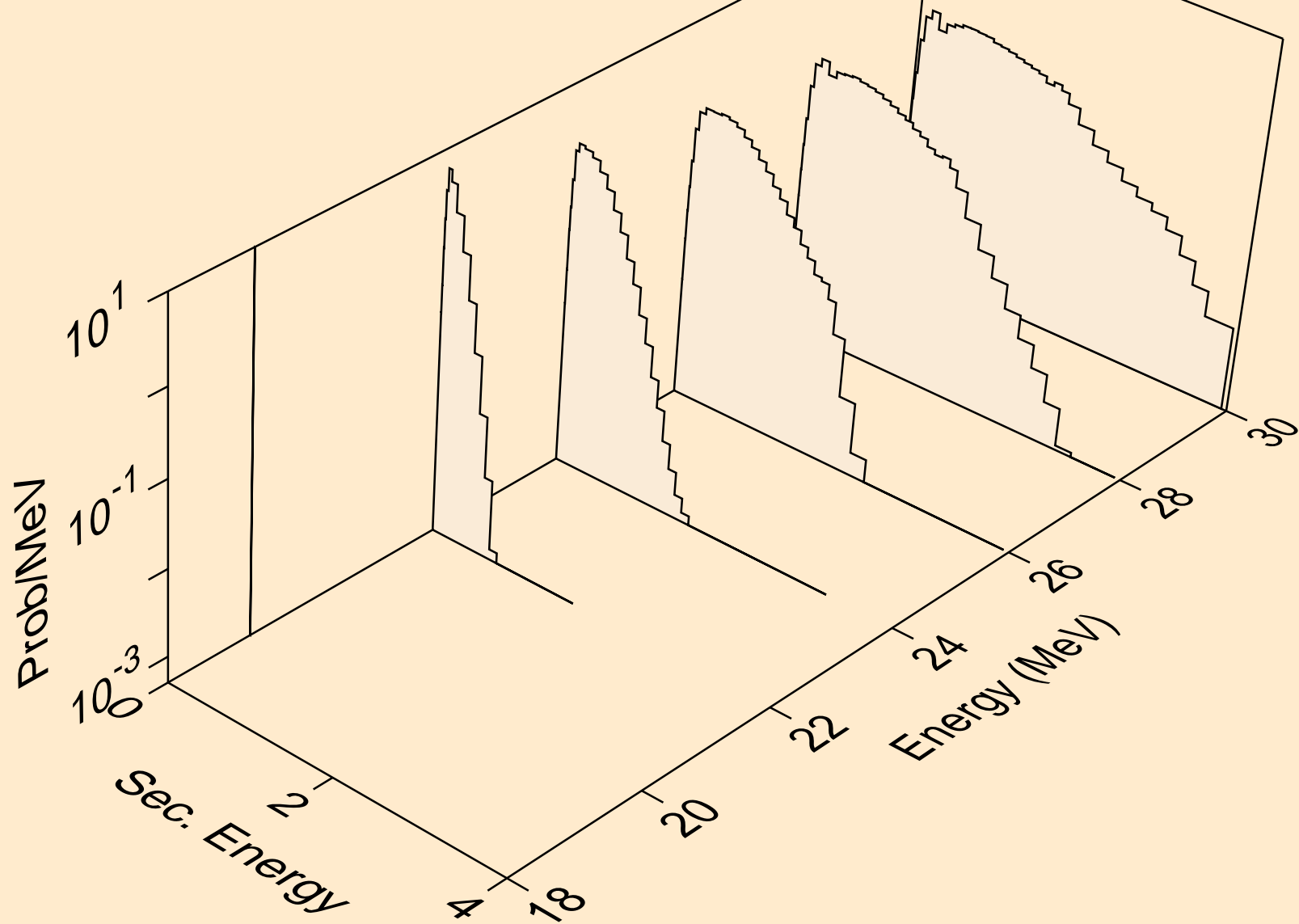

O021 ALPHA ACER TENDL-2024 LIBRARY; T=0.K
neutrons from (a,2n)2a

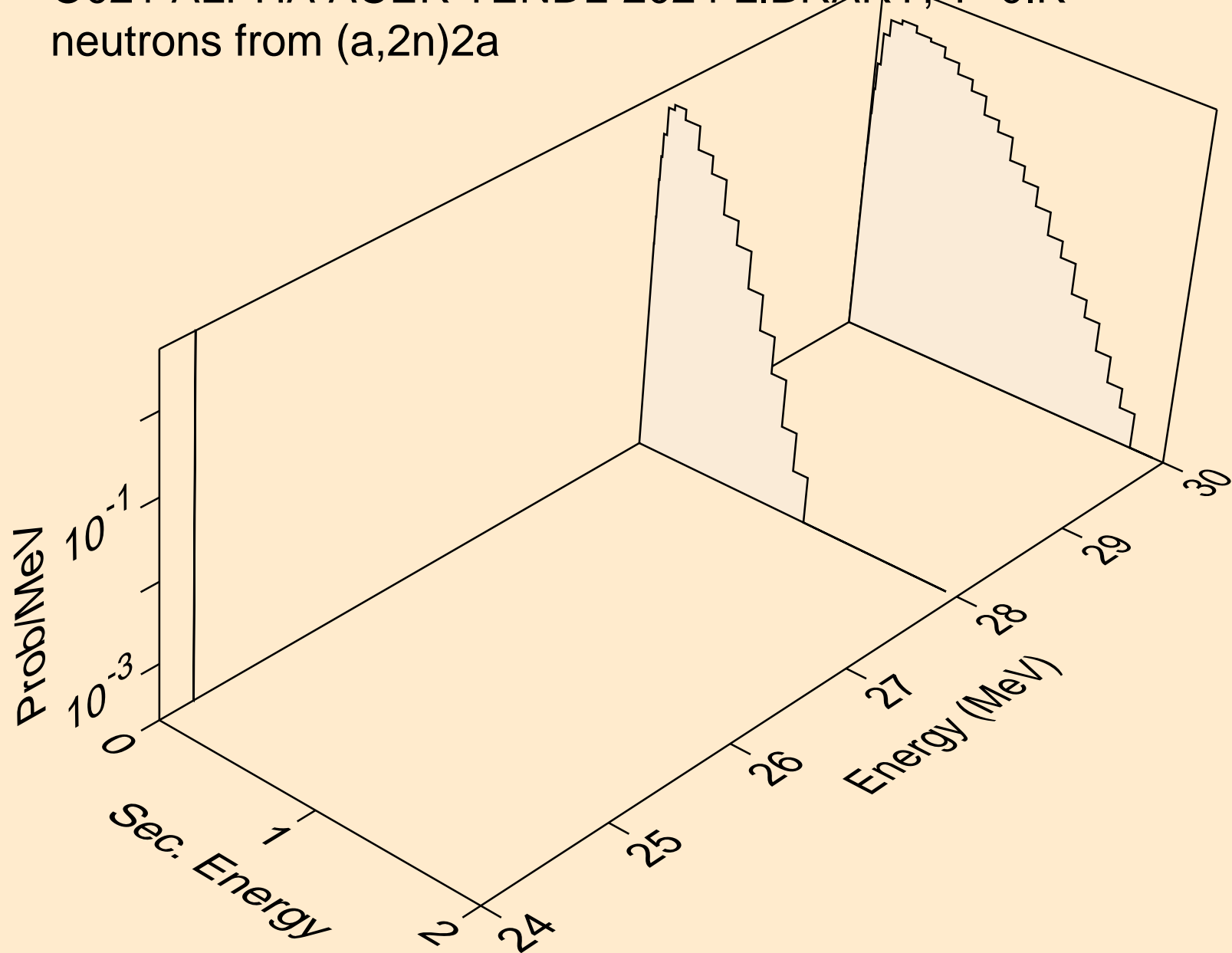

O021 ALPHA ACER TENDL-2024 LIBRARY; T=0.K
neutrons from (a,n*)d

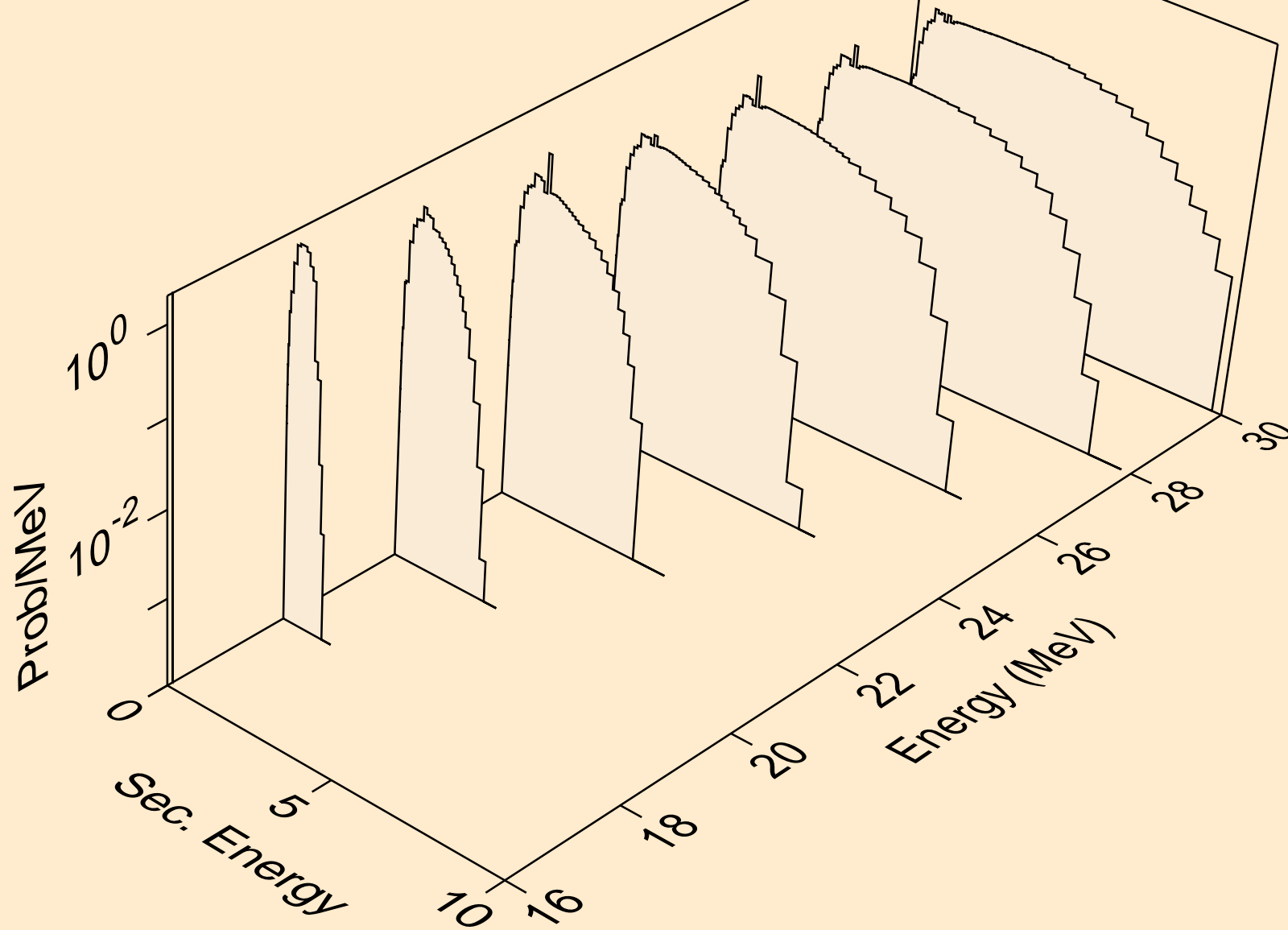

O021 ALPHA ACER TENDL-2024 LIBRARY; T=0.K
neutrons from (a,n*)t

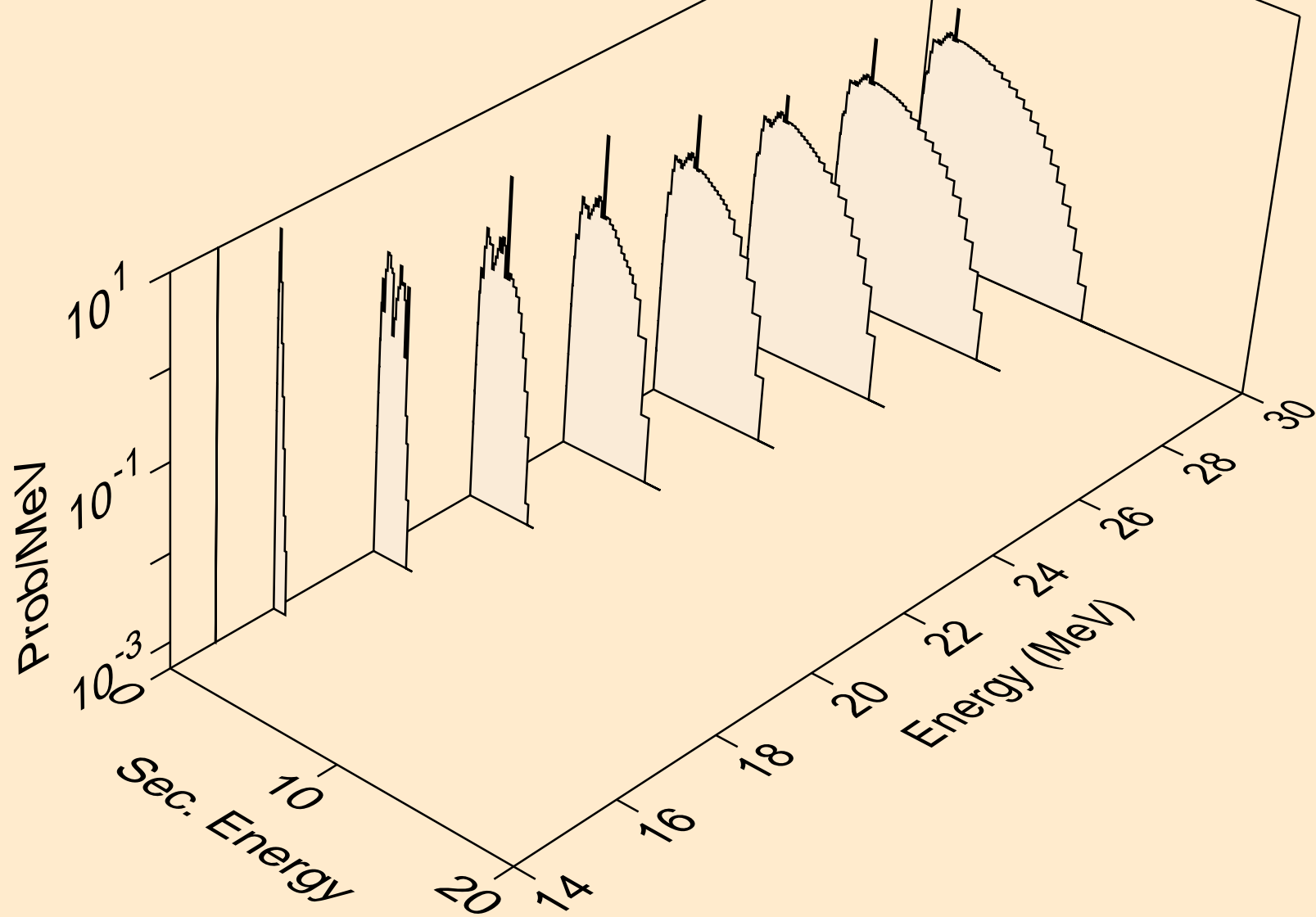

O021 ALPHA ACER TENDL-2024 LIBRARY; T=0.K
neutrons from (a,n*)he3

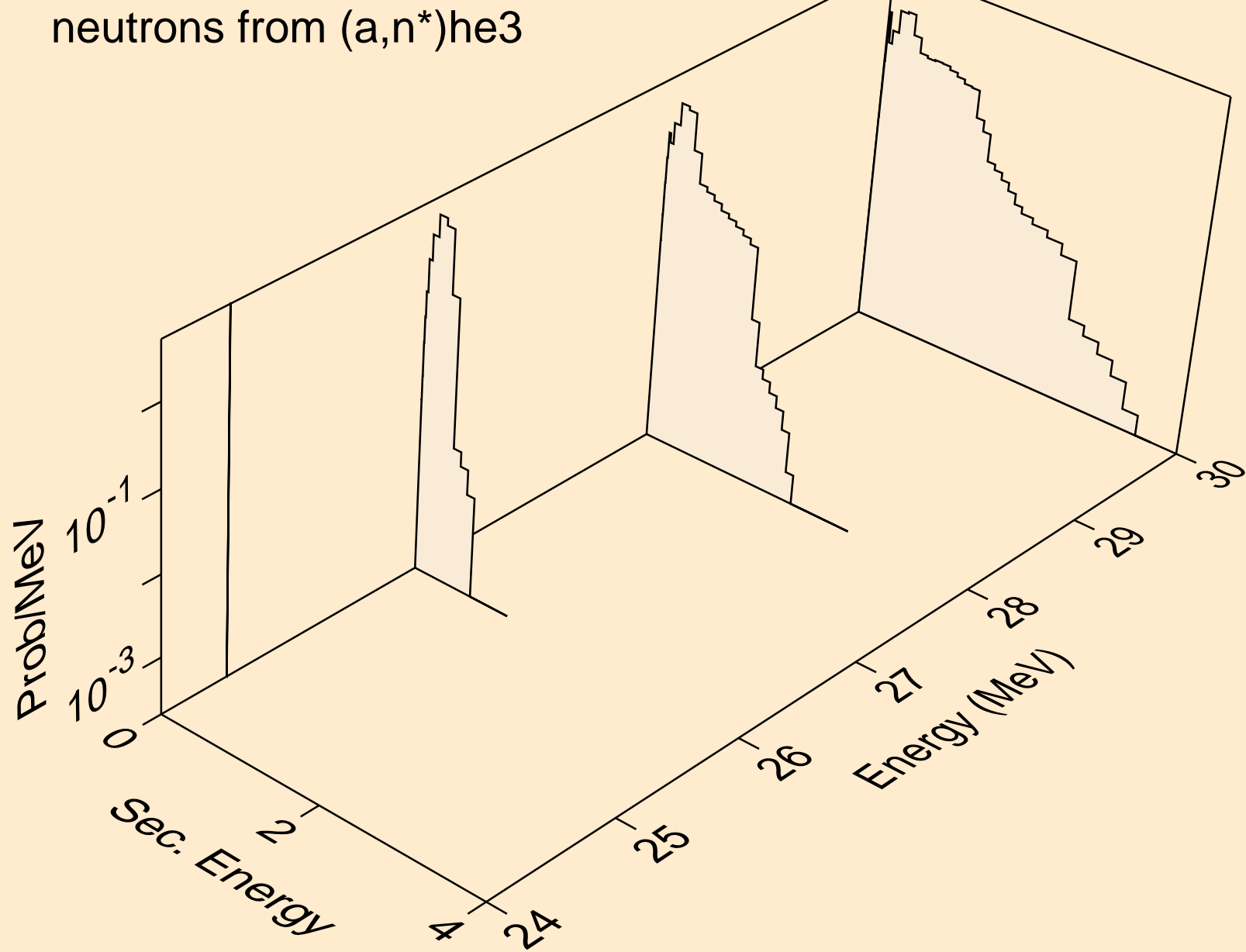

O021 ALPHA ACER TENDL-2024 LIBRARY; T=0.K
neutrons from (a,4n)

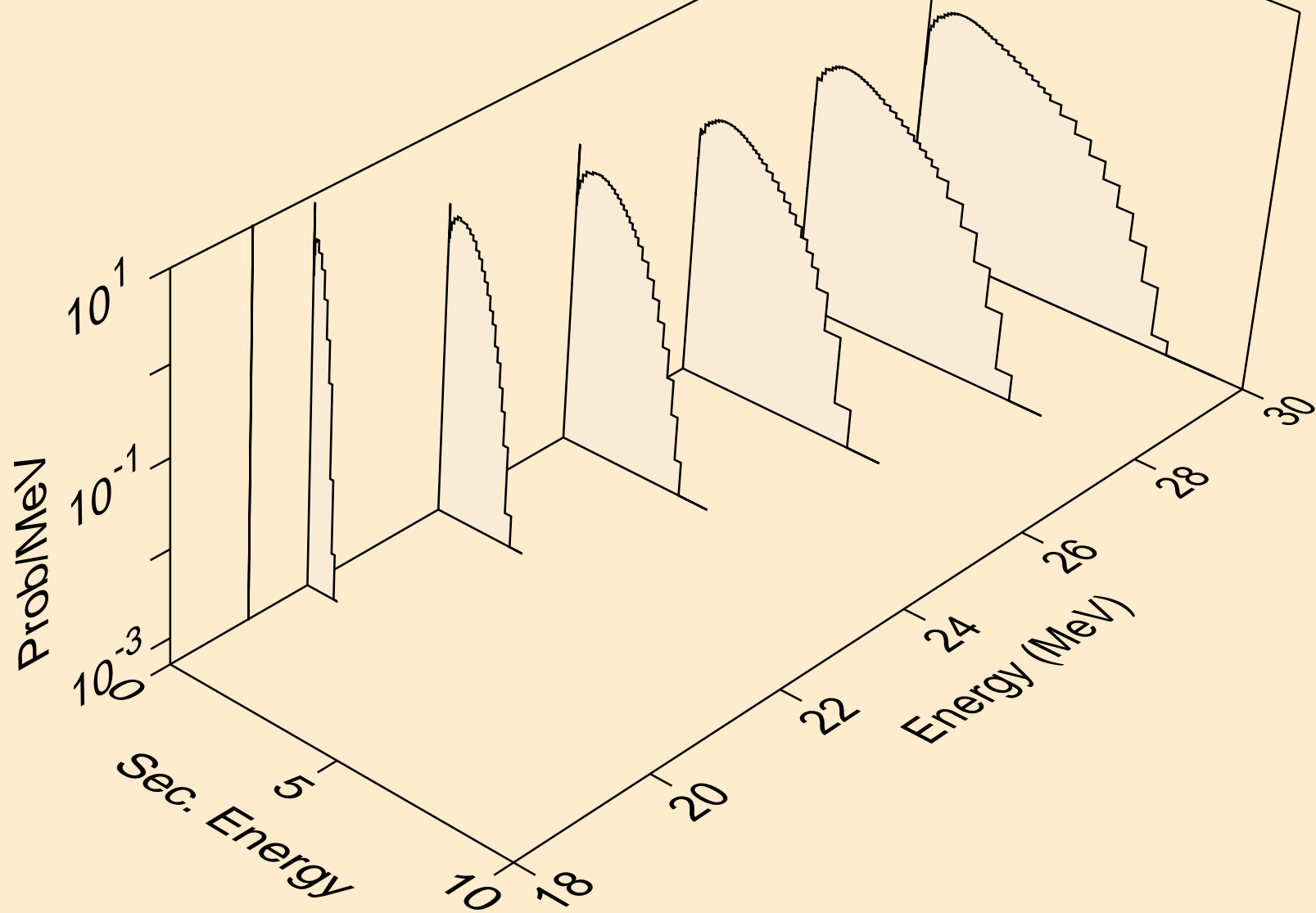

O021 ALPHA ACER TENDL-2024 LIBRARY; T=0.K
neutrons from (a,2np)

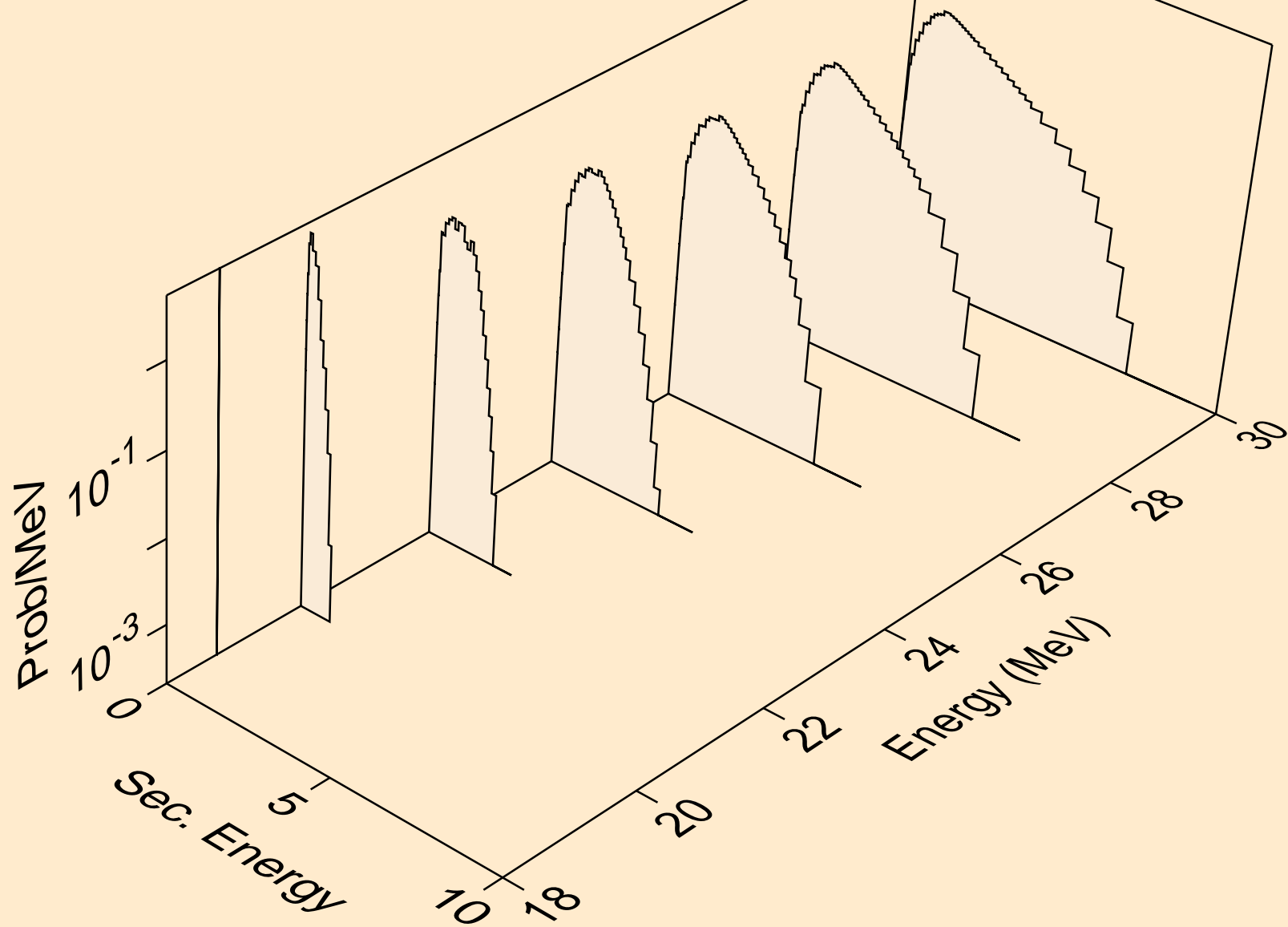

O021 ALPHA ACER TENDL-2024 LIBRARY; T=0.K
neutrons from (a,3np)

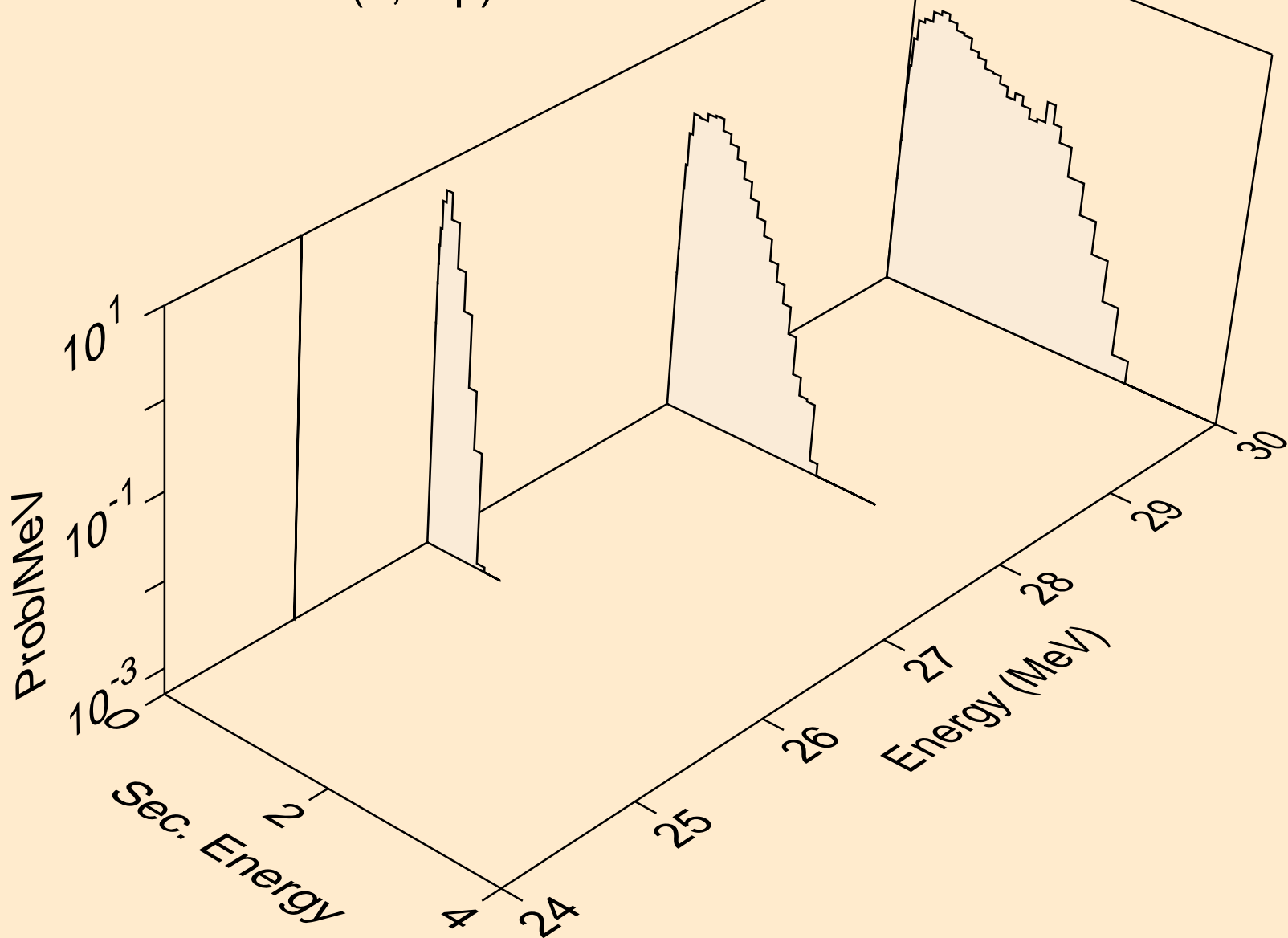

O021 ALPHA ACER TENDL-2024 LIBRARY; T=0.K
neutrons from (a,n2p)

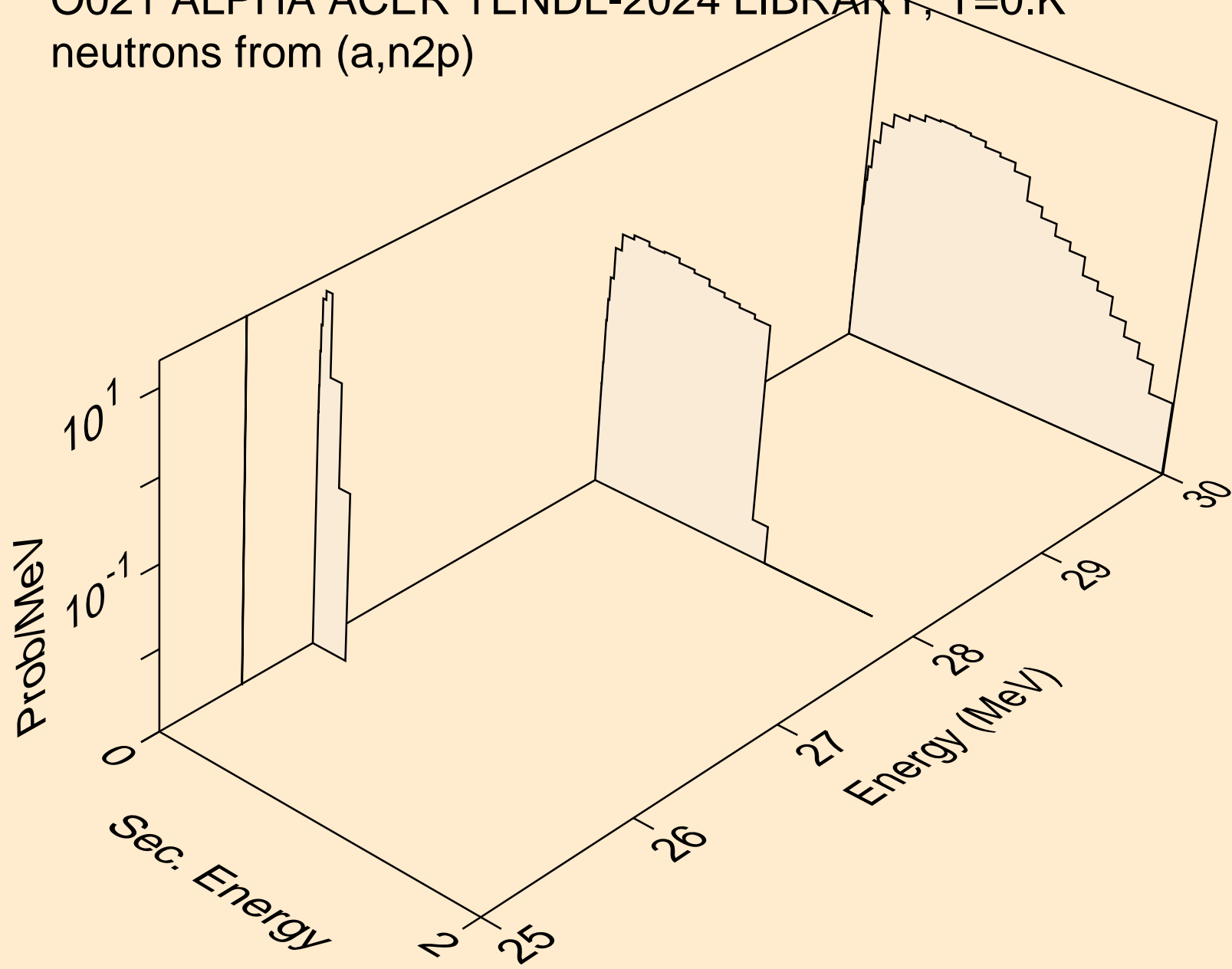

O021 ALPHA ACER TENDL-2024 LIBRARY; T=0.K
protons from (a,x)

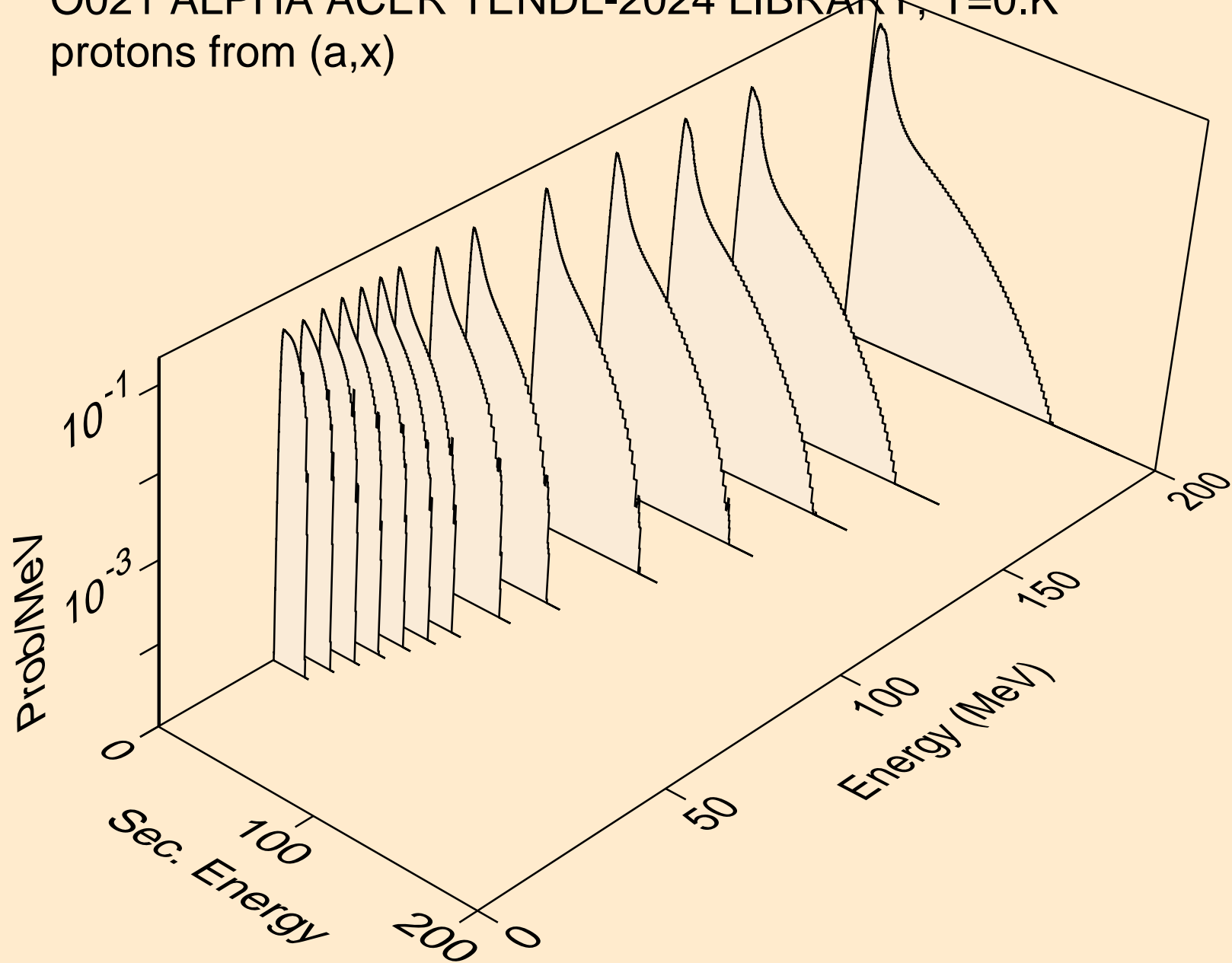

O021 ALPHA ACER TENDL-2024 LIBRARY; T=0.K
protons from (a,n*)p

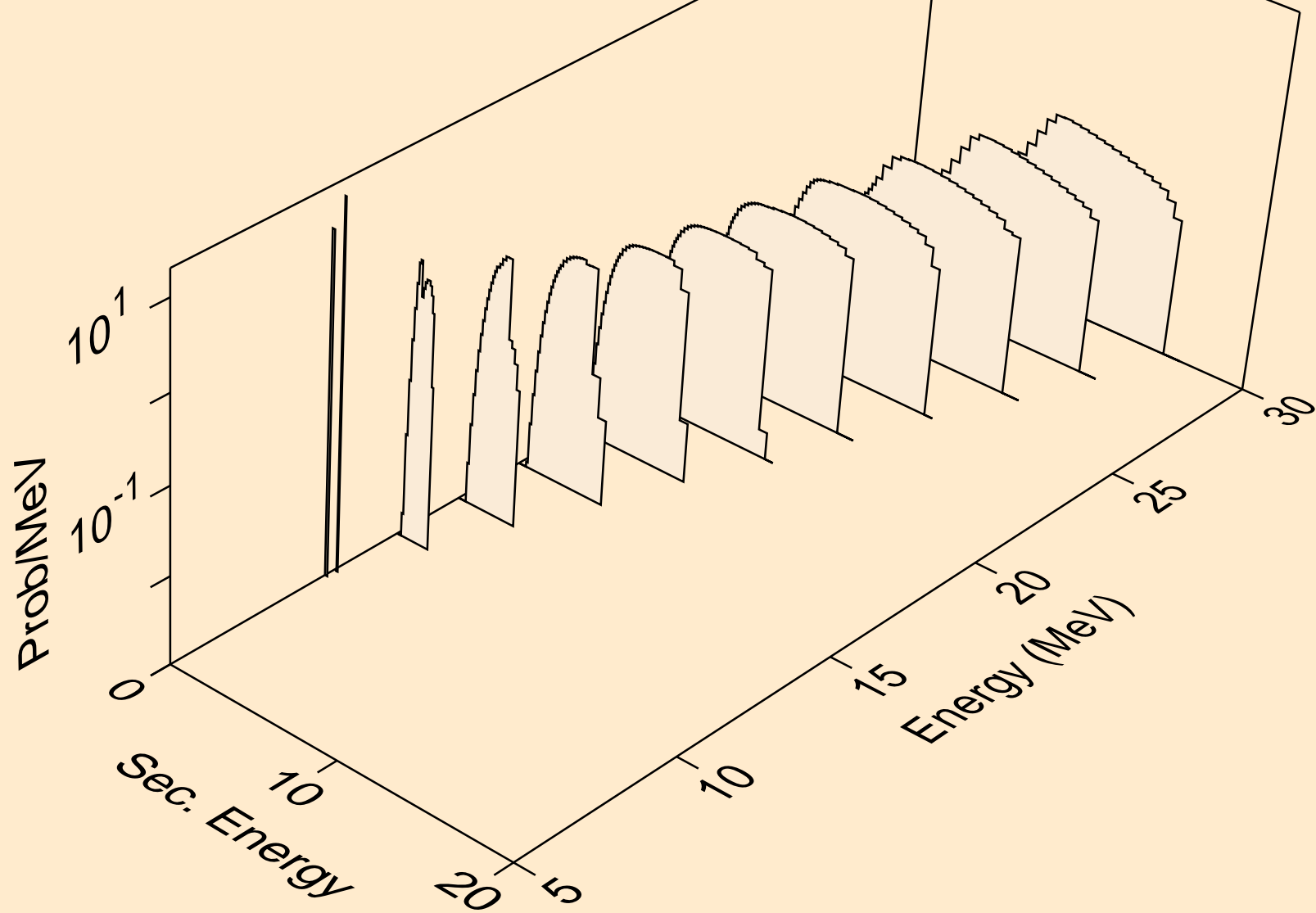

O021 ALPHA ACER TENDL-2024 LIBRARY; T=0.K
protons from (a,2np)

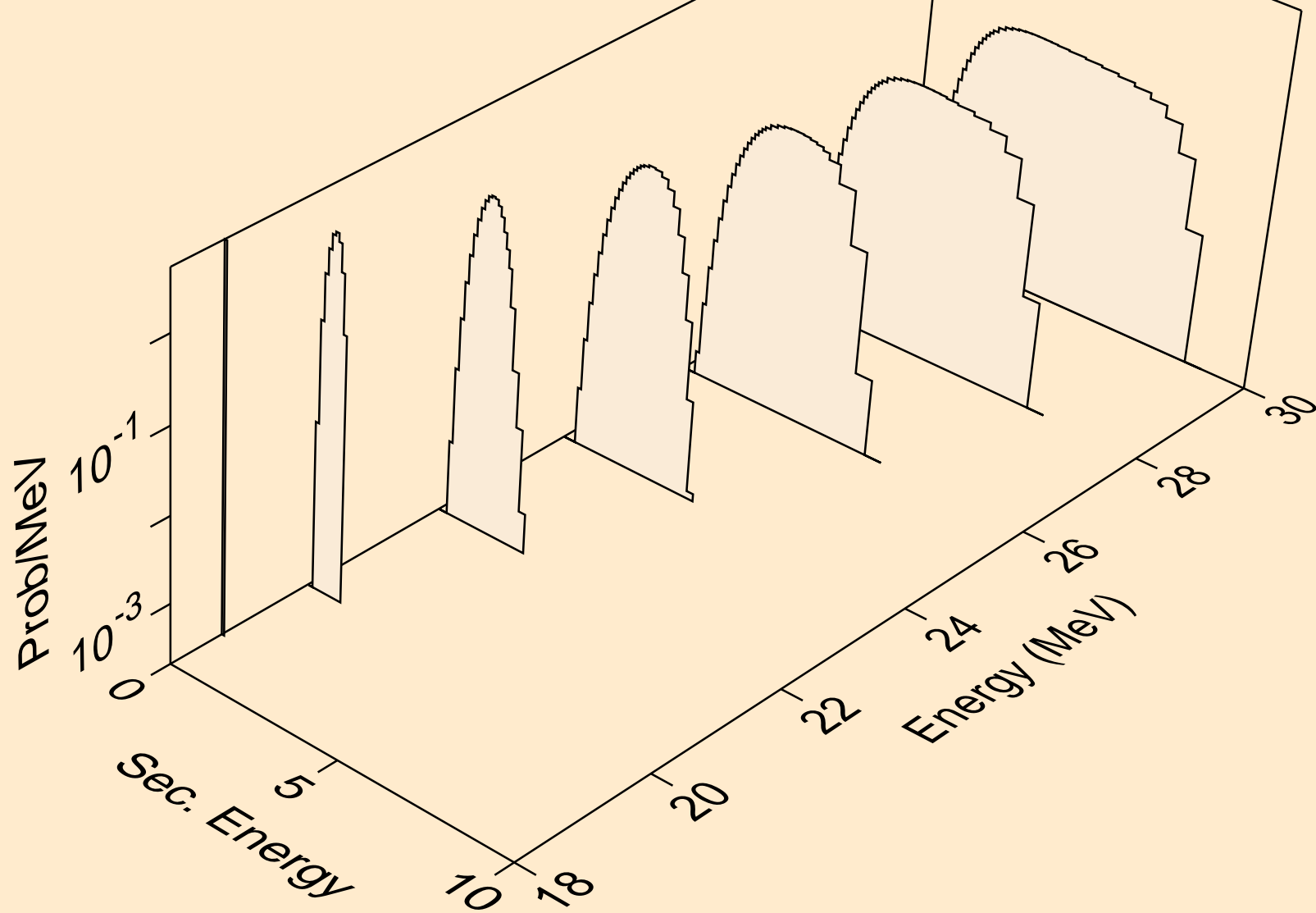

O021 ALPHA ACER TENDL-2024 LIBRARY; T=0.K
protons from (a,3np)

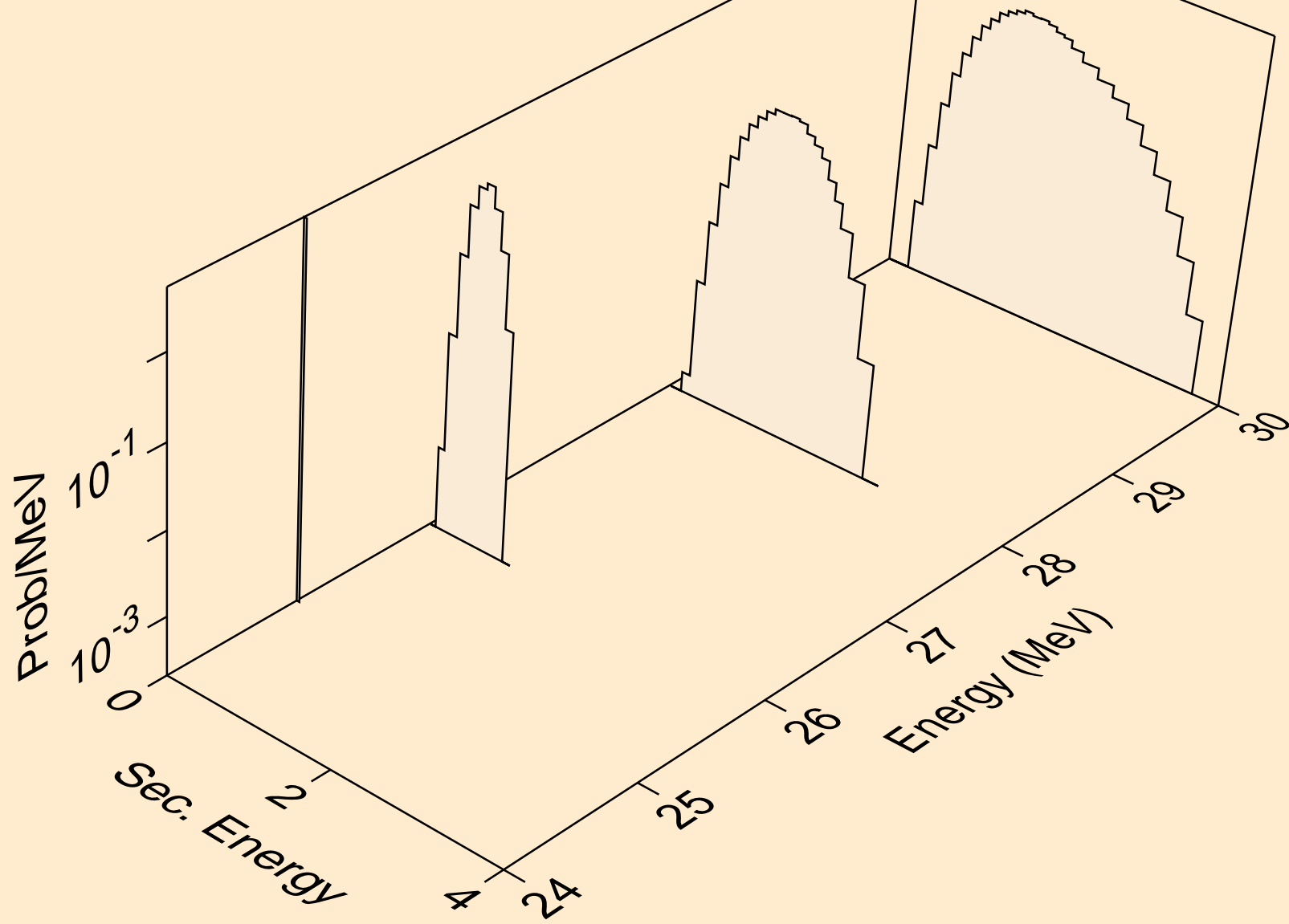

O021 ALPHA ACER TENDL-2024 LIBRARY; T=0.K
protons from (a,n2p)

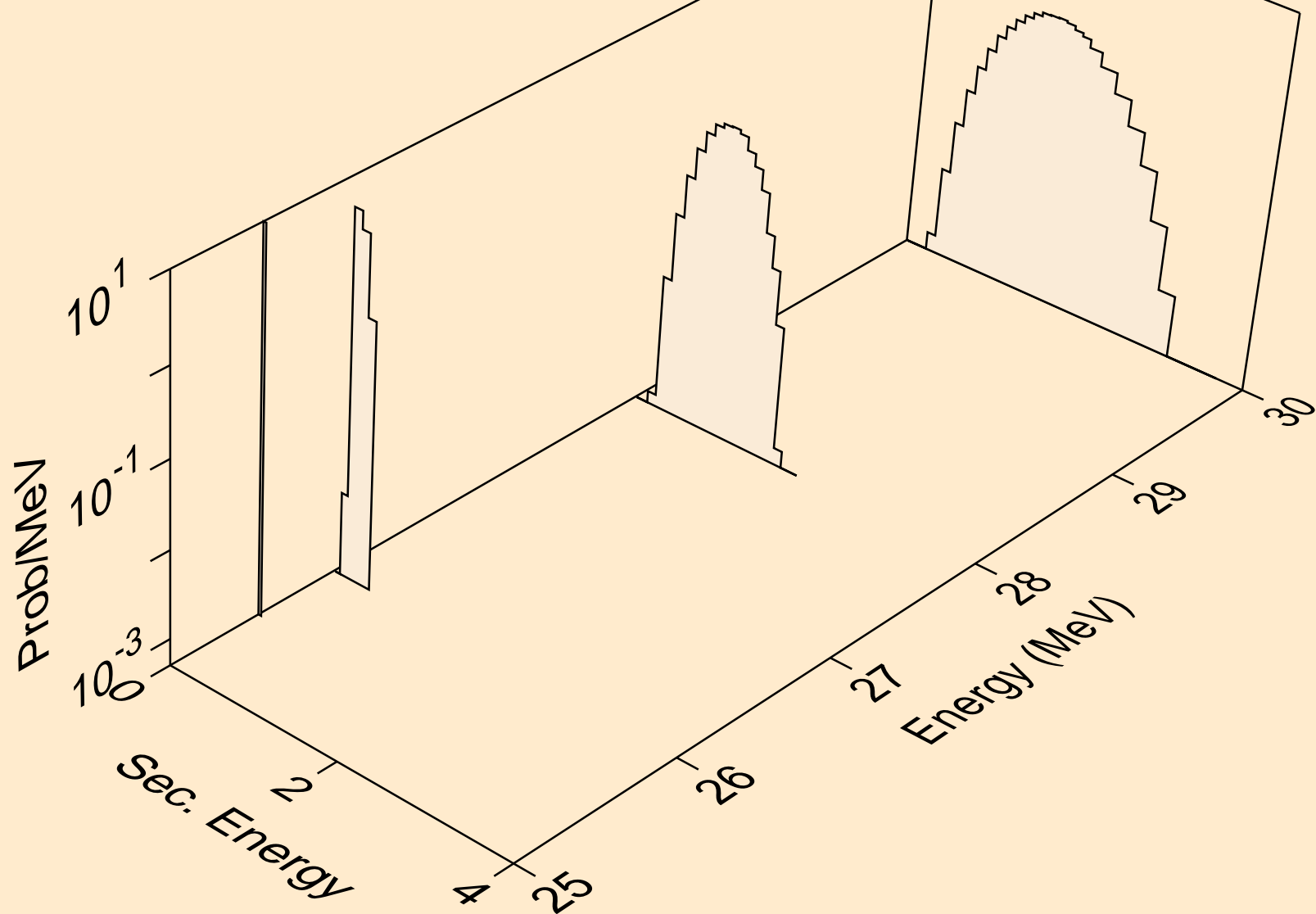

O021 ALPHA ACER TENDL-2024 LIBRARY; T=0.K
protons from (a,p)

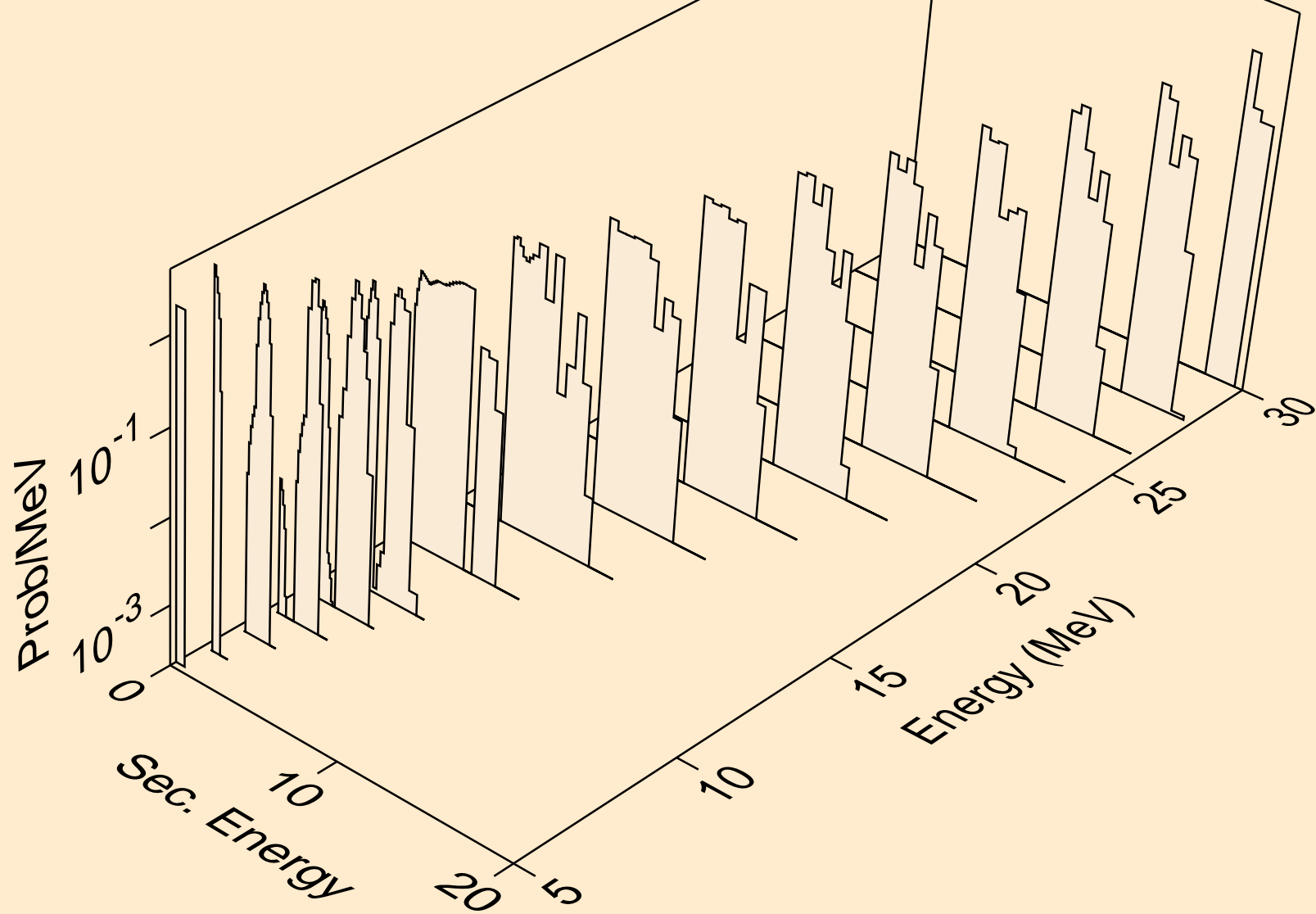

O021 ALPHA ACER TENDL-2024 LIBRARY; T=0.K
protons from (a,2p)

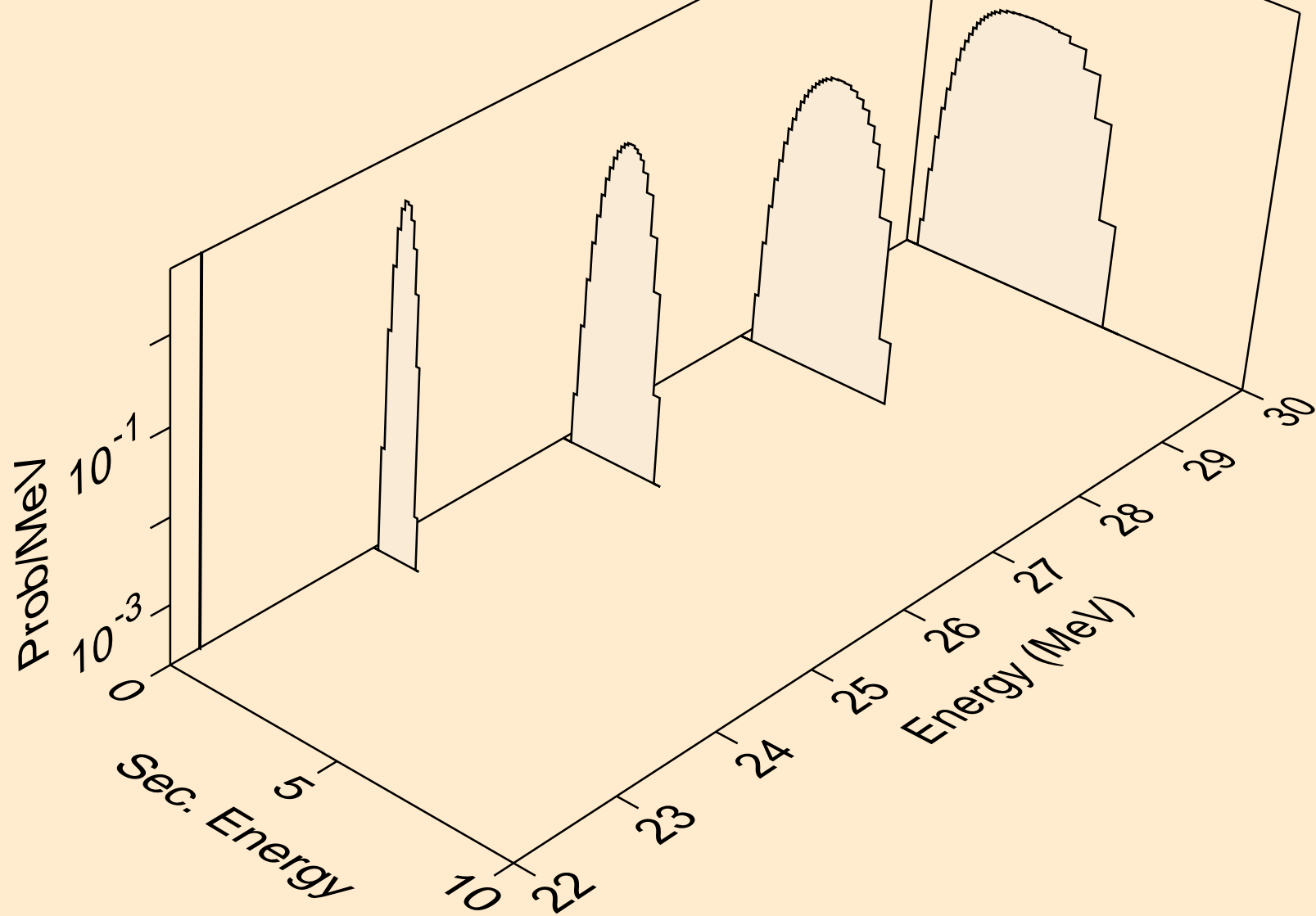

O021 ALPHA ACER TENDL-2024 LIBRARY; T=0.K
protons from (a,pa)

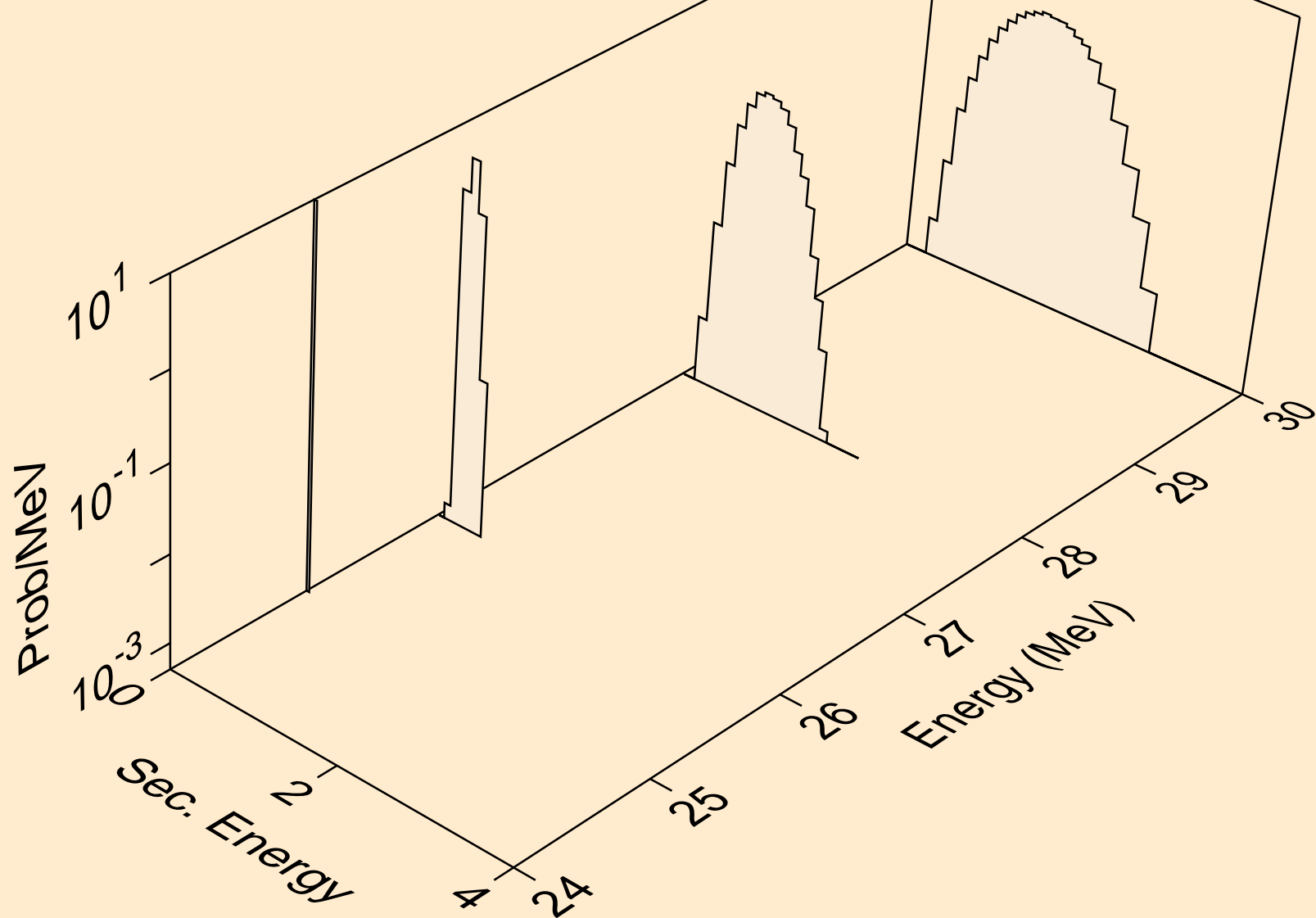

O021 ALPHA ACER TENDL-2024 LIBRARY; T=0.K
protons from (a,pd)

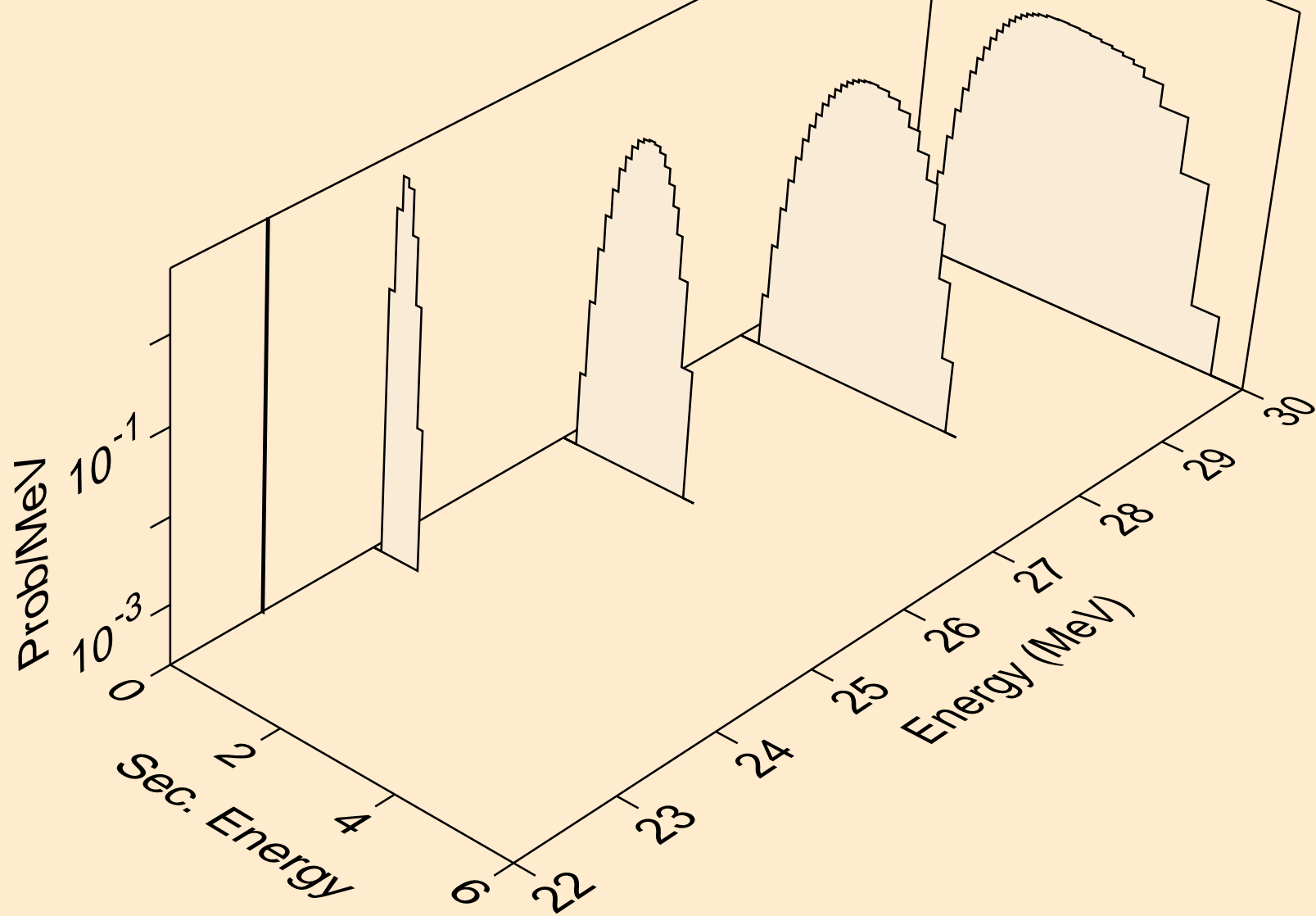

O021 ALPHA ACER TENDL-2024 LIBRARY; T=0.K
protons from (a,pt)

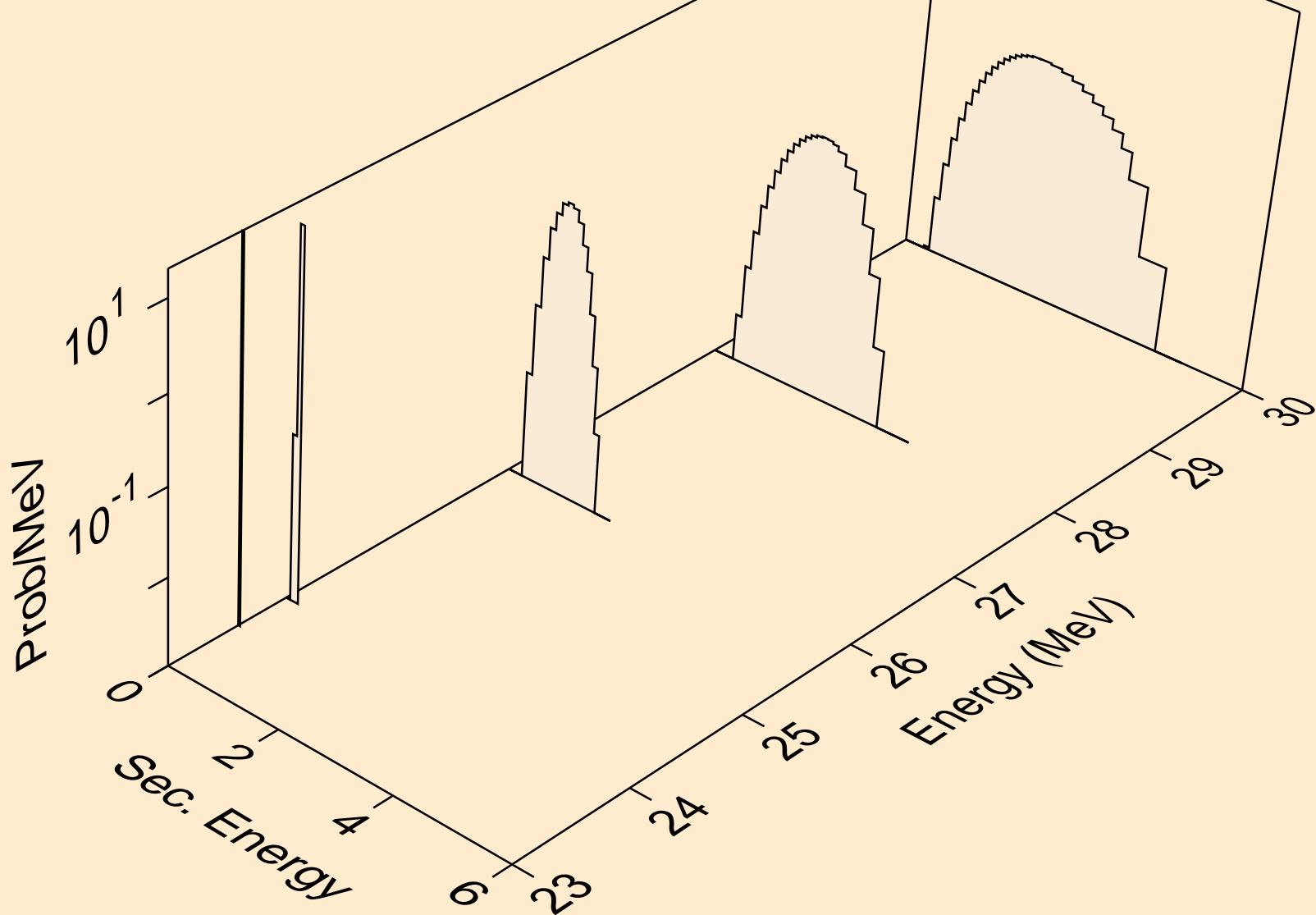

O021 ALPHA ACER TENDL-2024 LIBRARY; T=0.K
deuterons from (a,x)

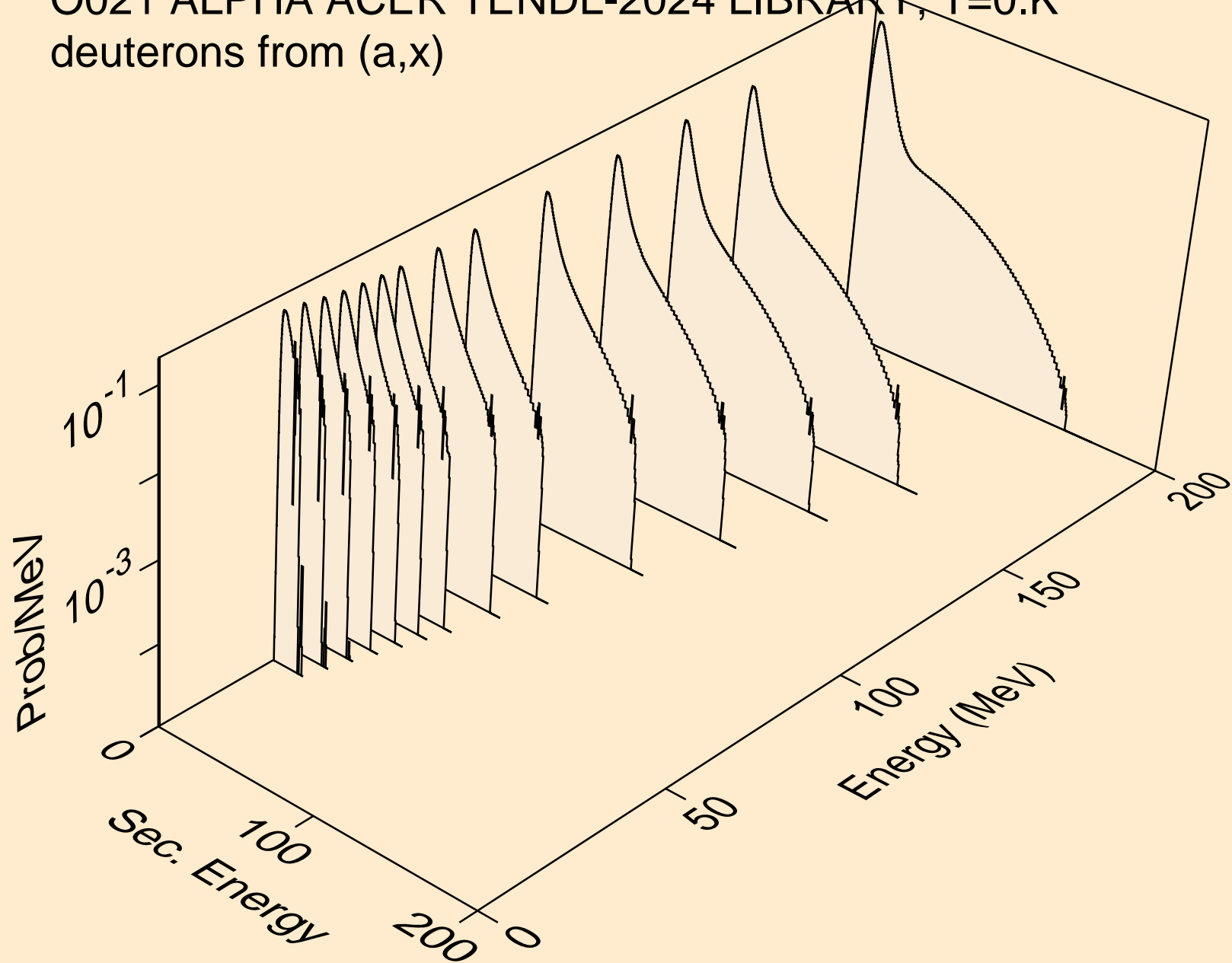

O021 ALPHA ACER TENDL-2024 LIBRARY; T=0.K
deuterons from (a,2nd)

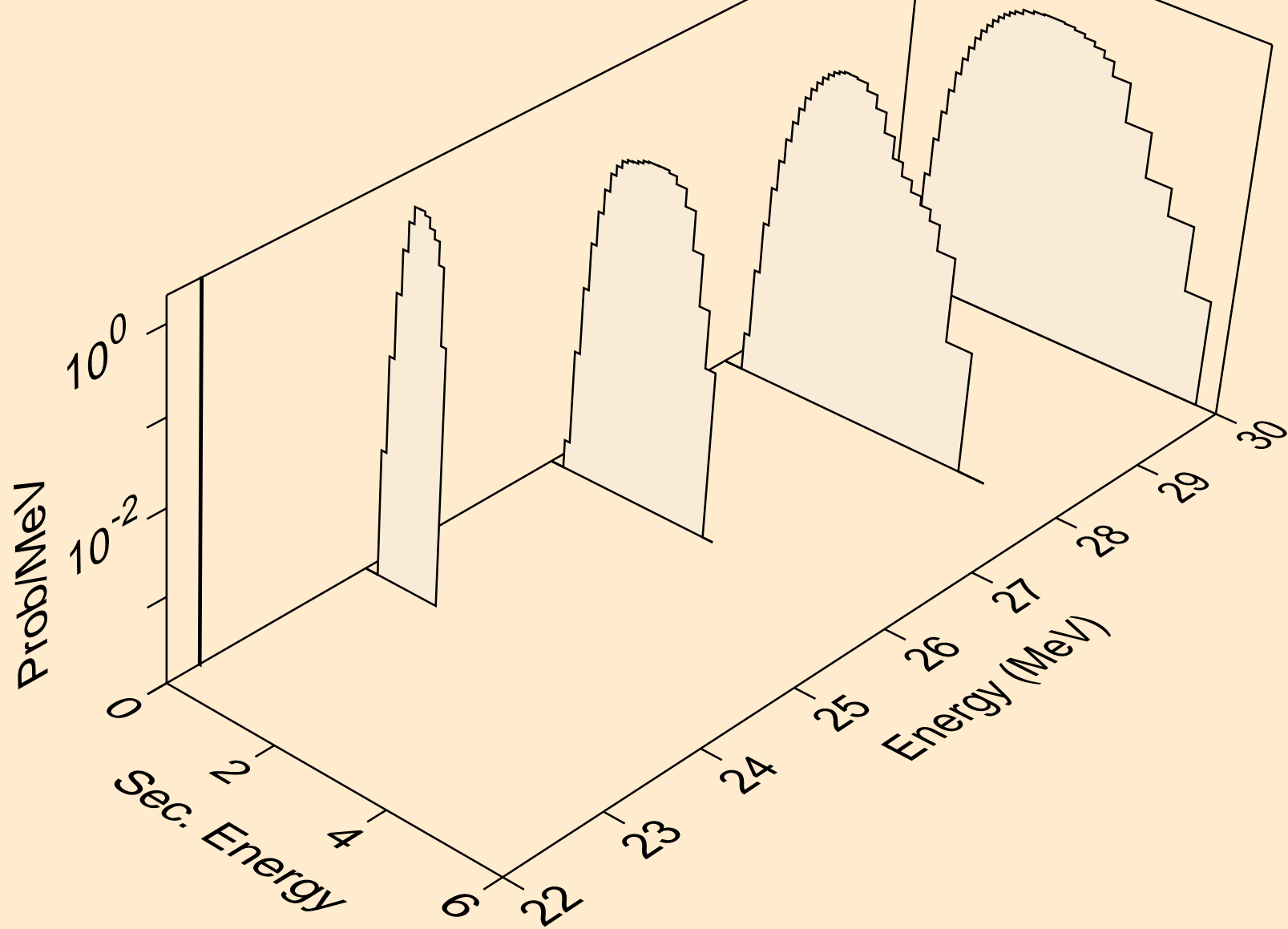

O021 ALPHA ACER TENDL-2024 LIBRARY; T=0.K
deuterons from (a,n*)d

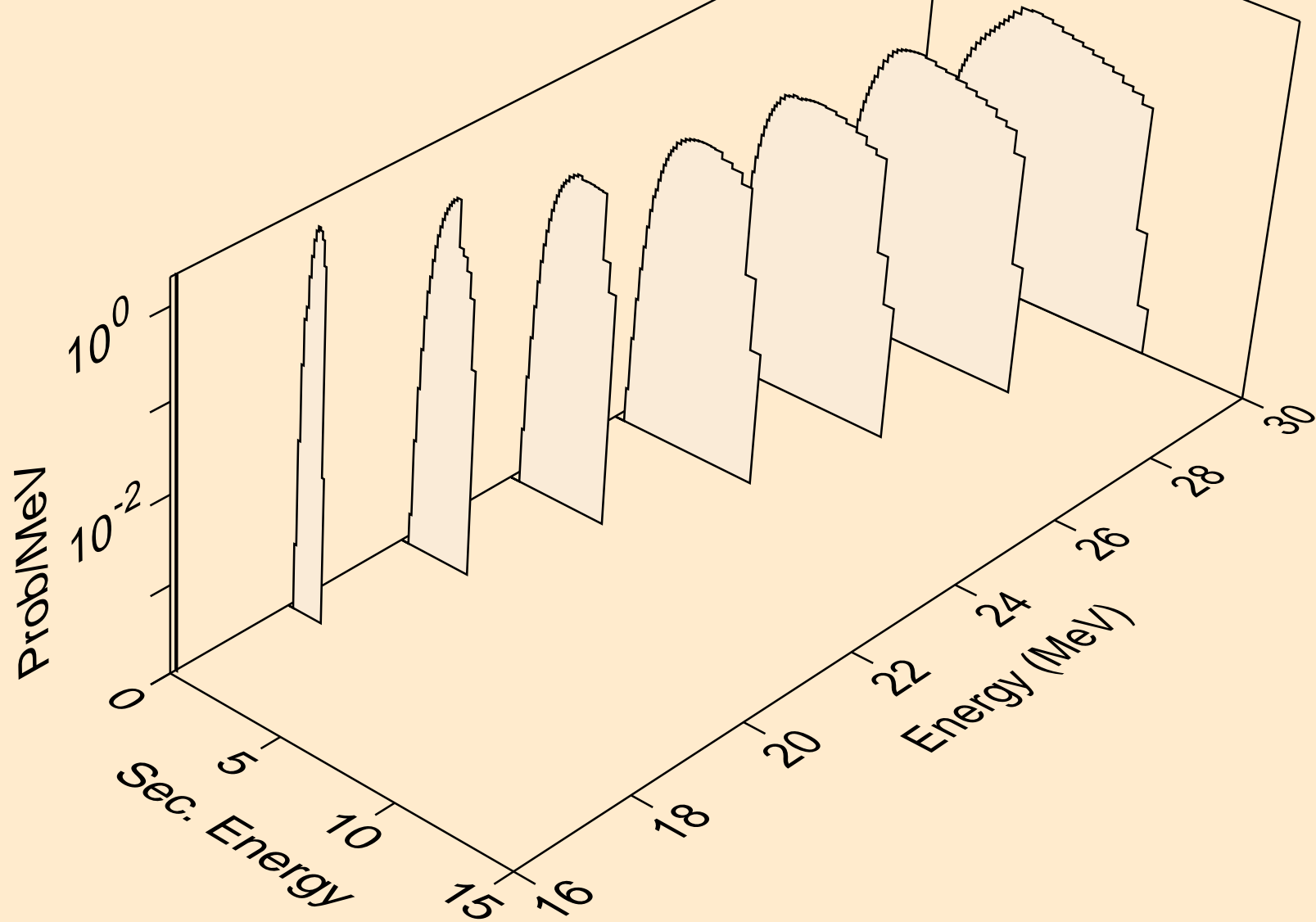

O021 ALPHA ACER TENDL-2024 LIBRARY; T=0.K
deuterons from (a,d)

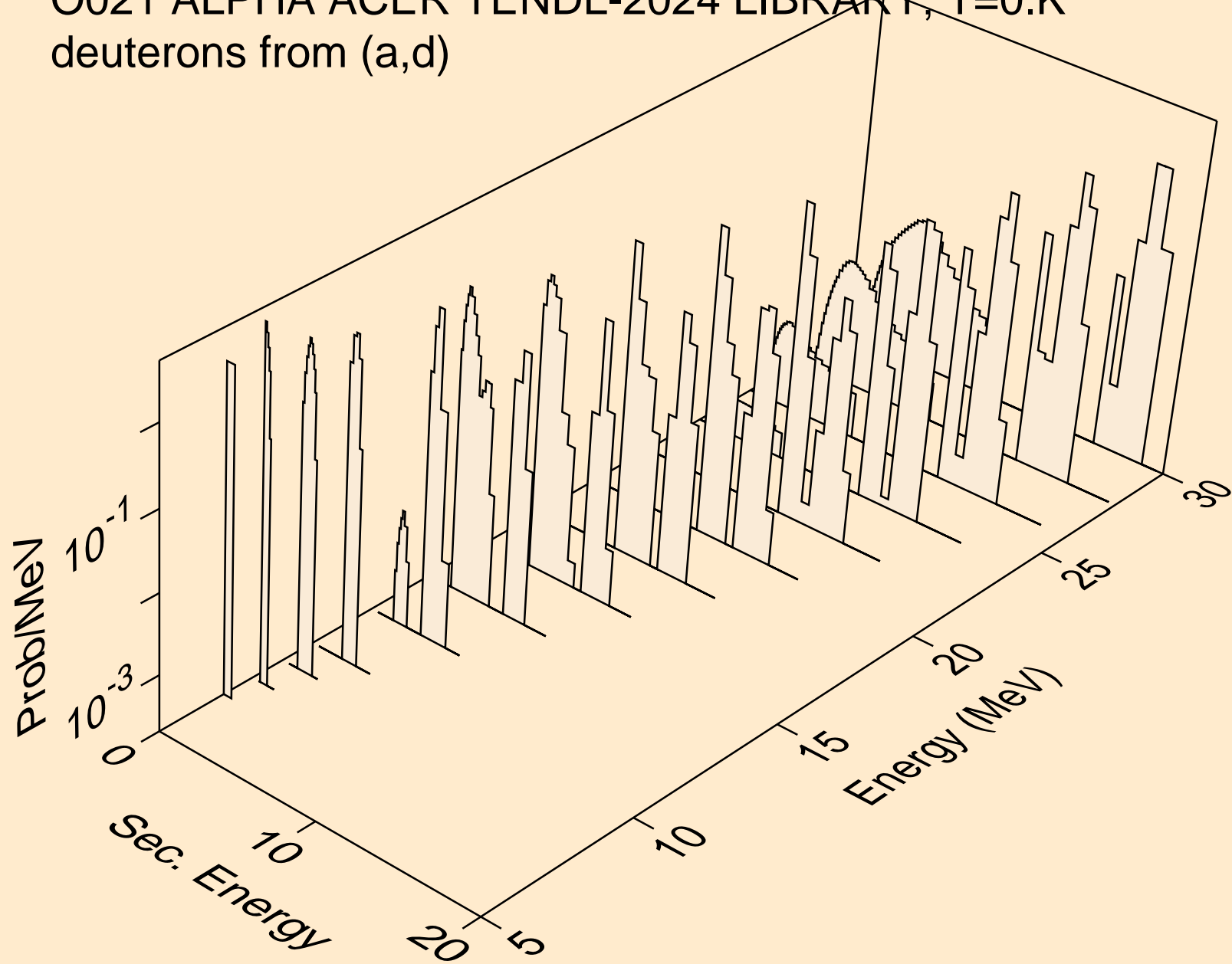

O021 ALPHA ACER TENDL-2024 LIBRARY; T=0.K
deuterons from (a,pd)

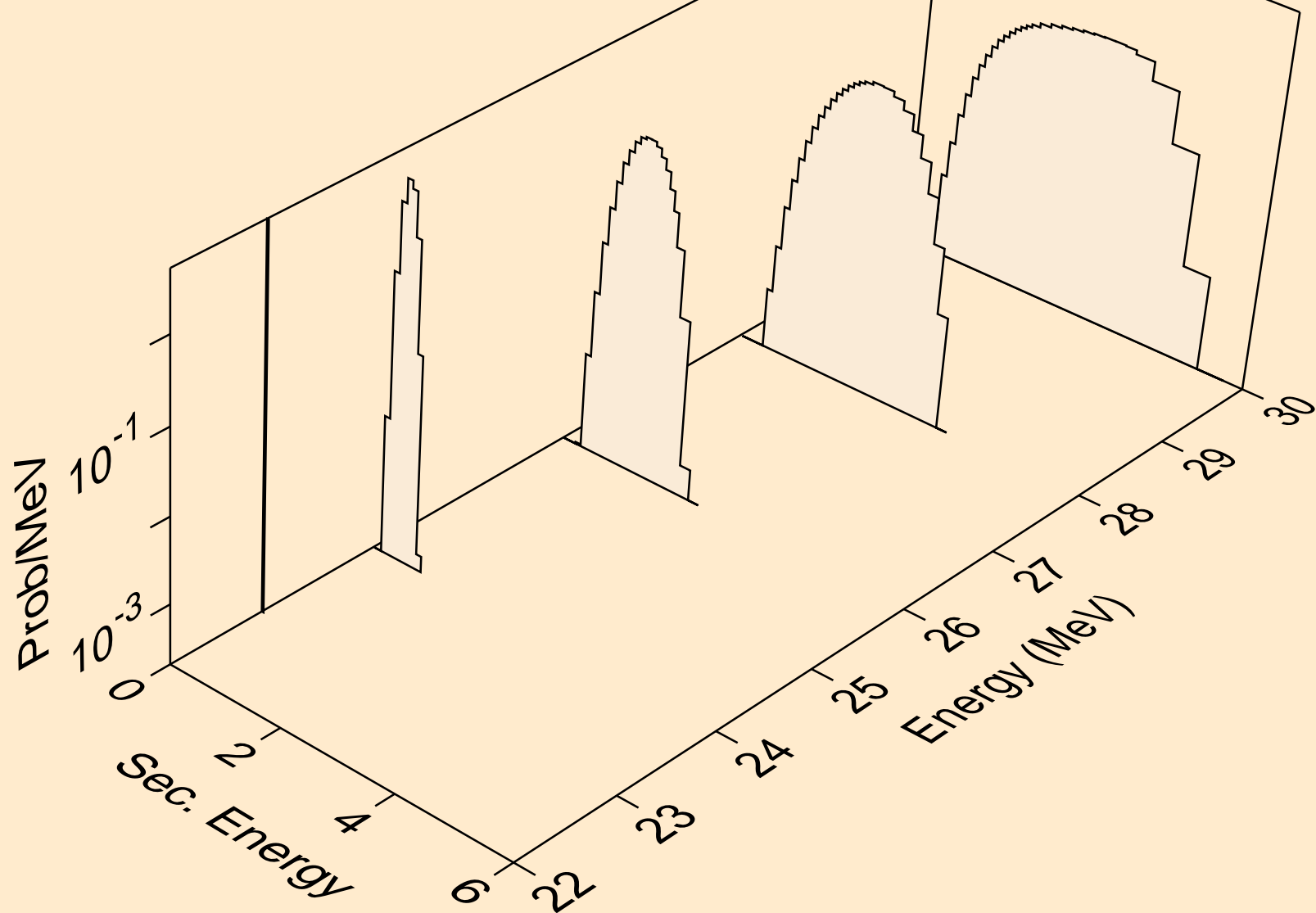

O021 ALPHA ACER TENDL-2024 LIBRARY; T=0.K
deuterons from (a,da)

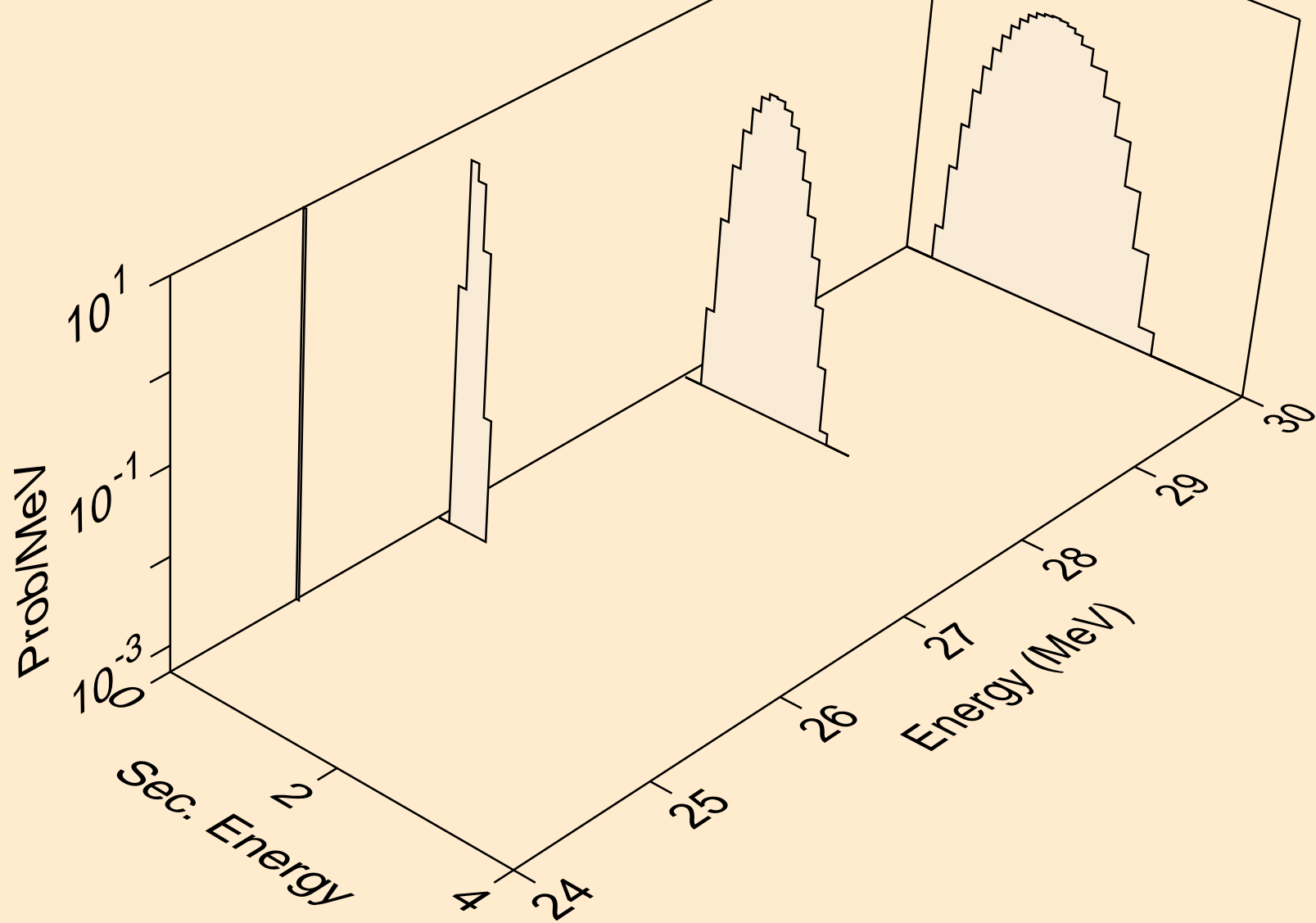

O021 ALPHA ACER TENDL-2024 LIBRARY; T=0.K
tritons from (a,x)

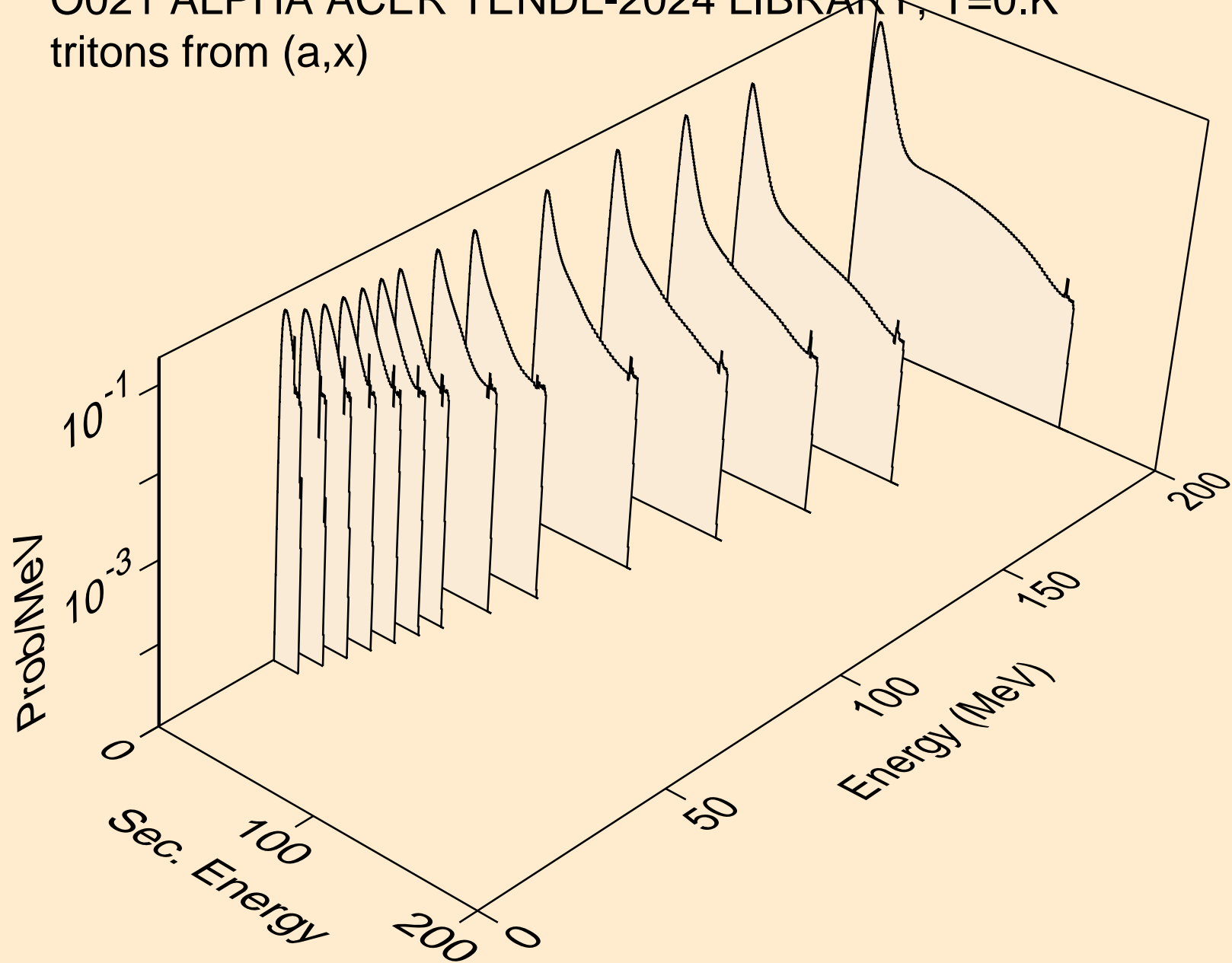

O021 ALPHA ACER TENDL-2024 LIBRARY; T=0.K
tritons from (a,n*)t

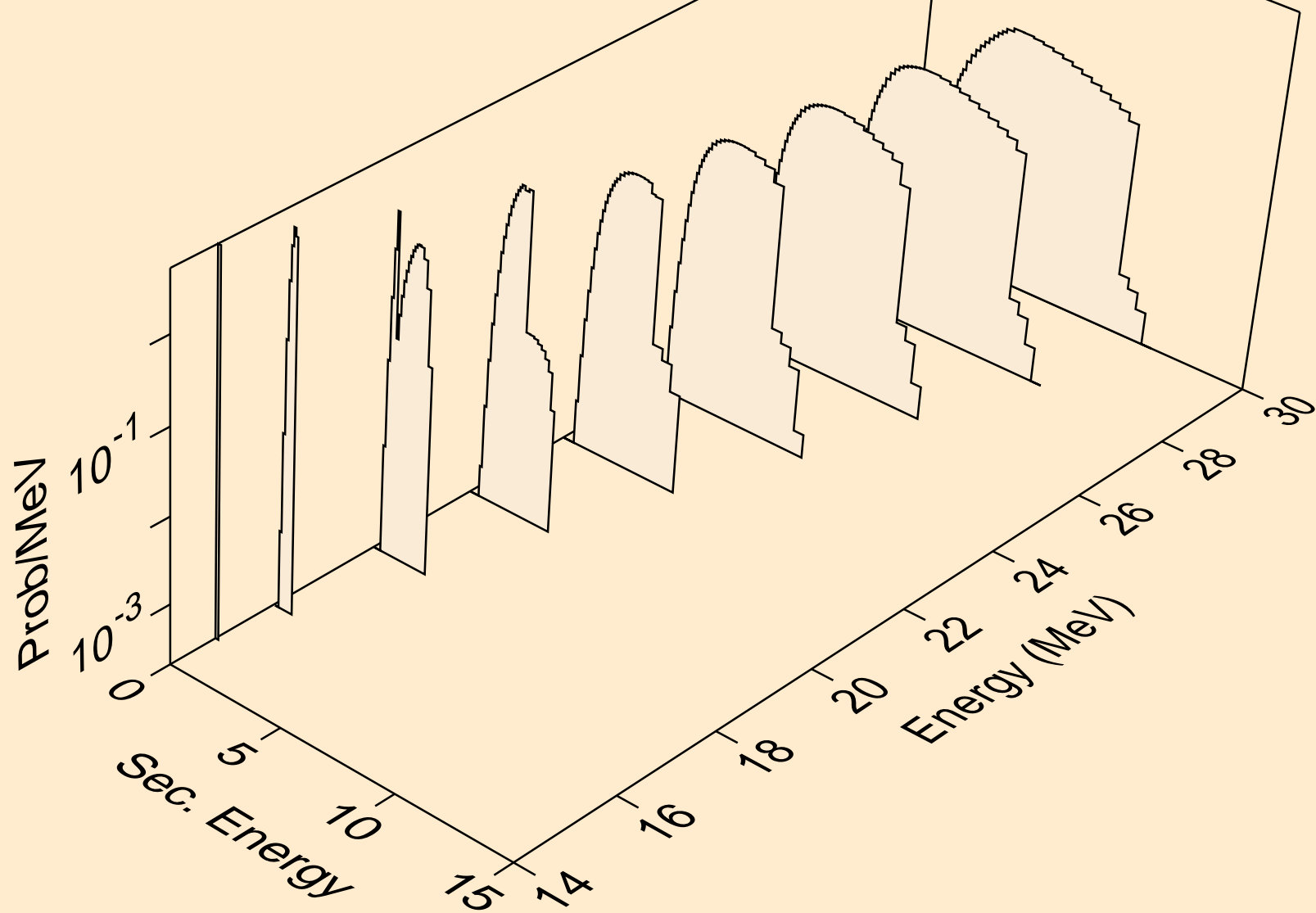

O021 ALPHA ACER TENDL-2024 LIBRARY; T=0.K
tritons from (a,t)

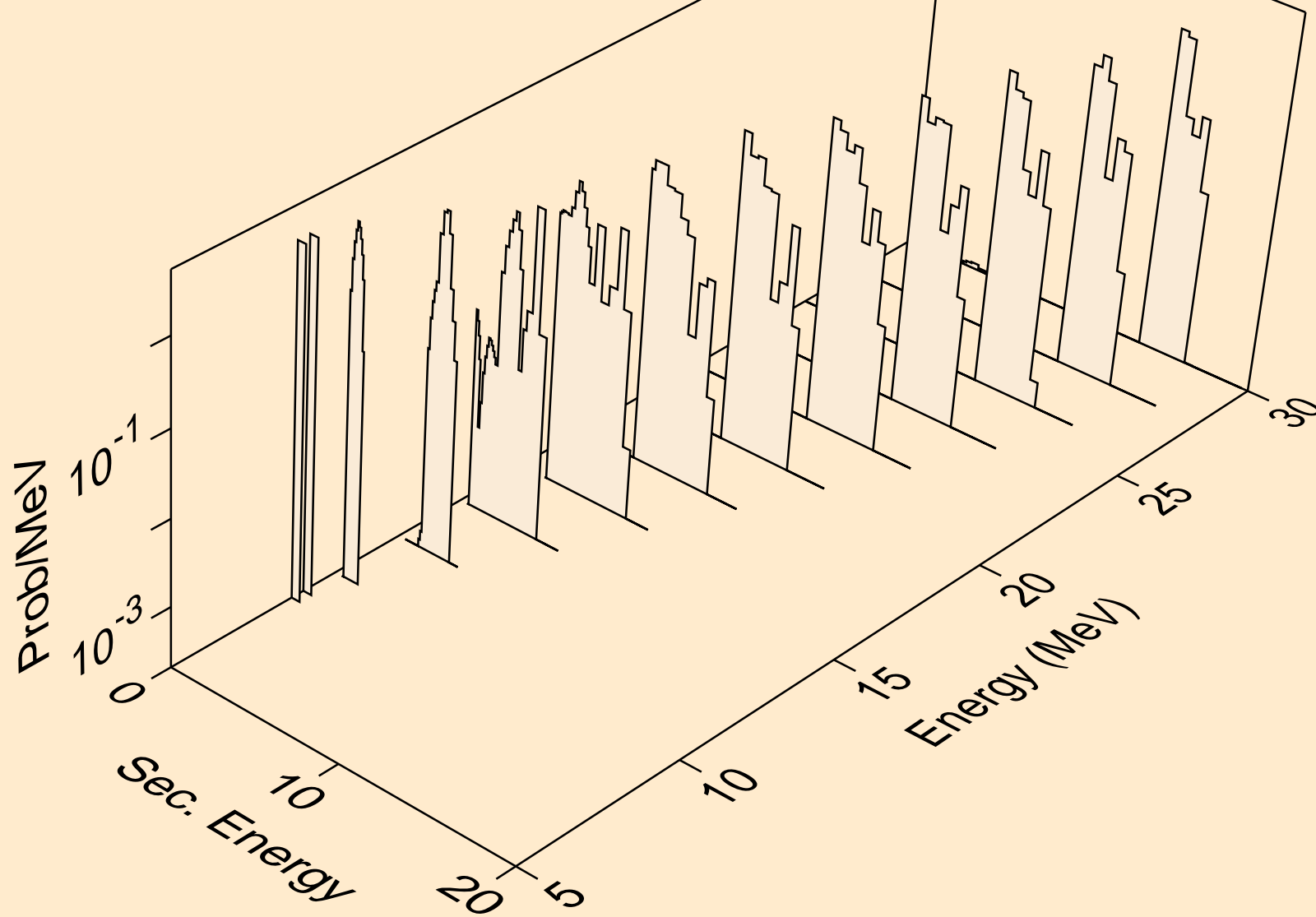

O021 ALPHA ACER TENDL-2024 LIBRARY; T=0.K
tritons from (a,pt)

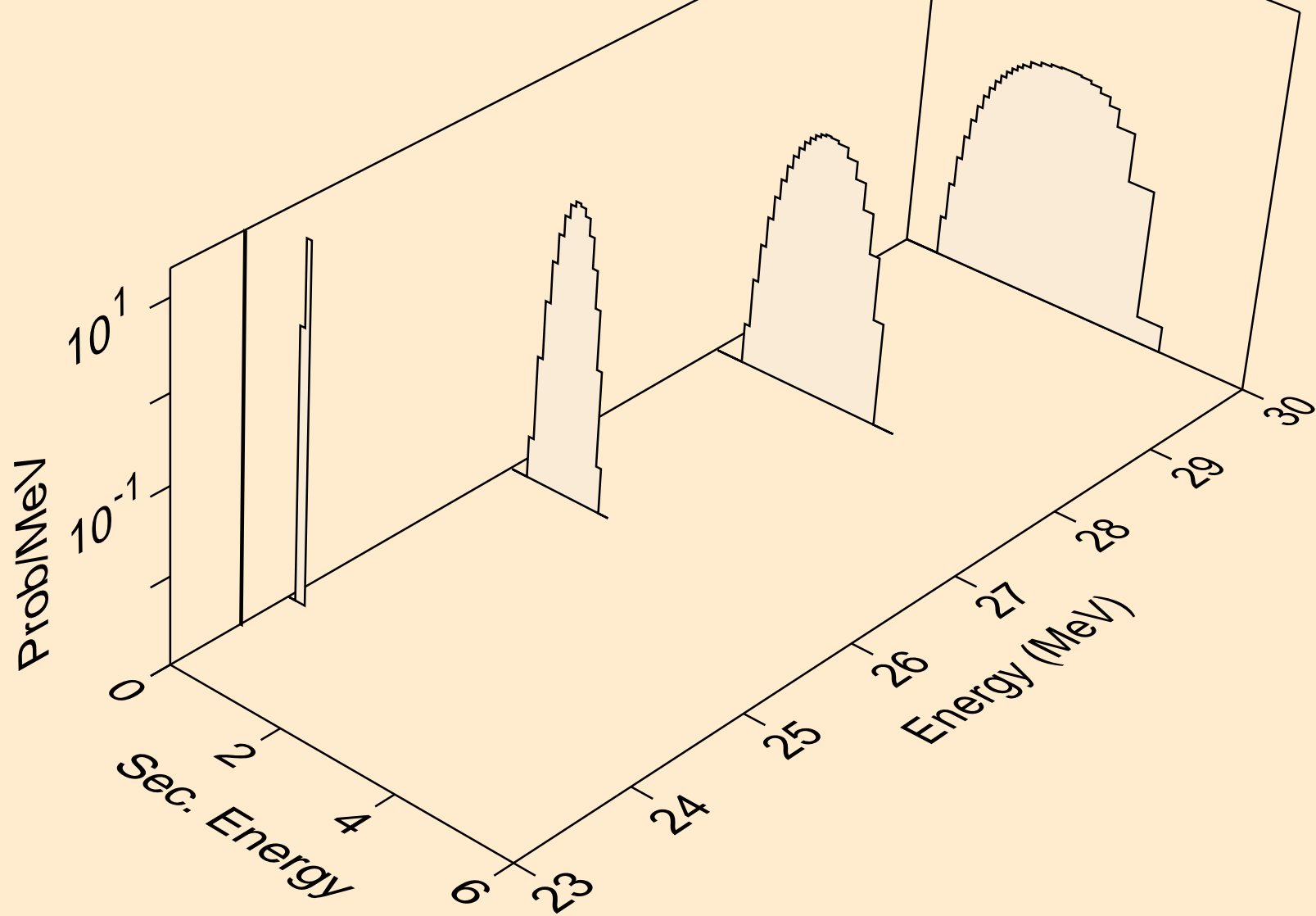

O021 ALPHA ACER TENDL-2024 LIBRARY; T=0.K
he3s from (a,x)

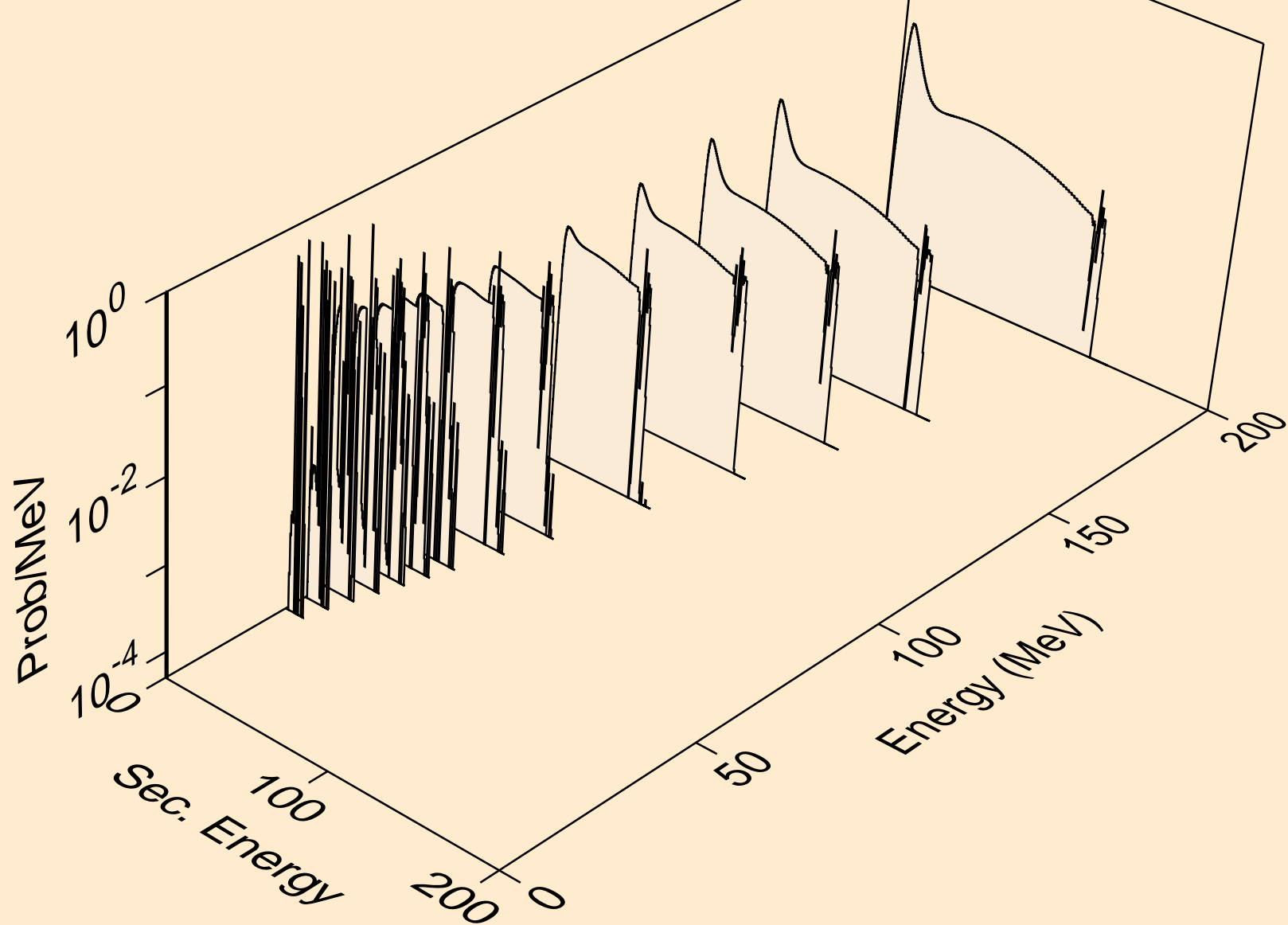

O021 ALPHA ACER TENDL-2024 LIBRARY; T=0.K
he3s from (a,n*)he3

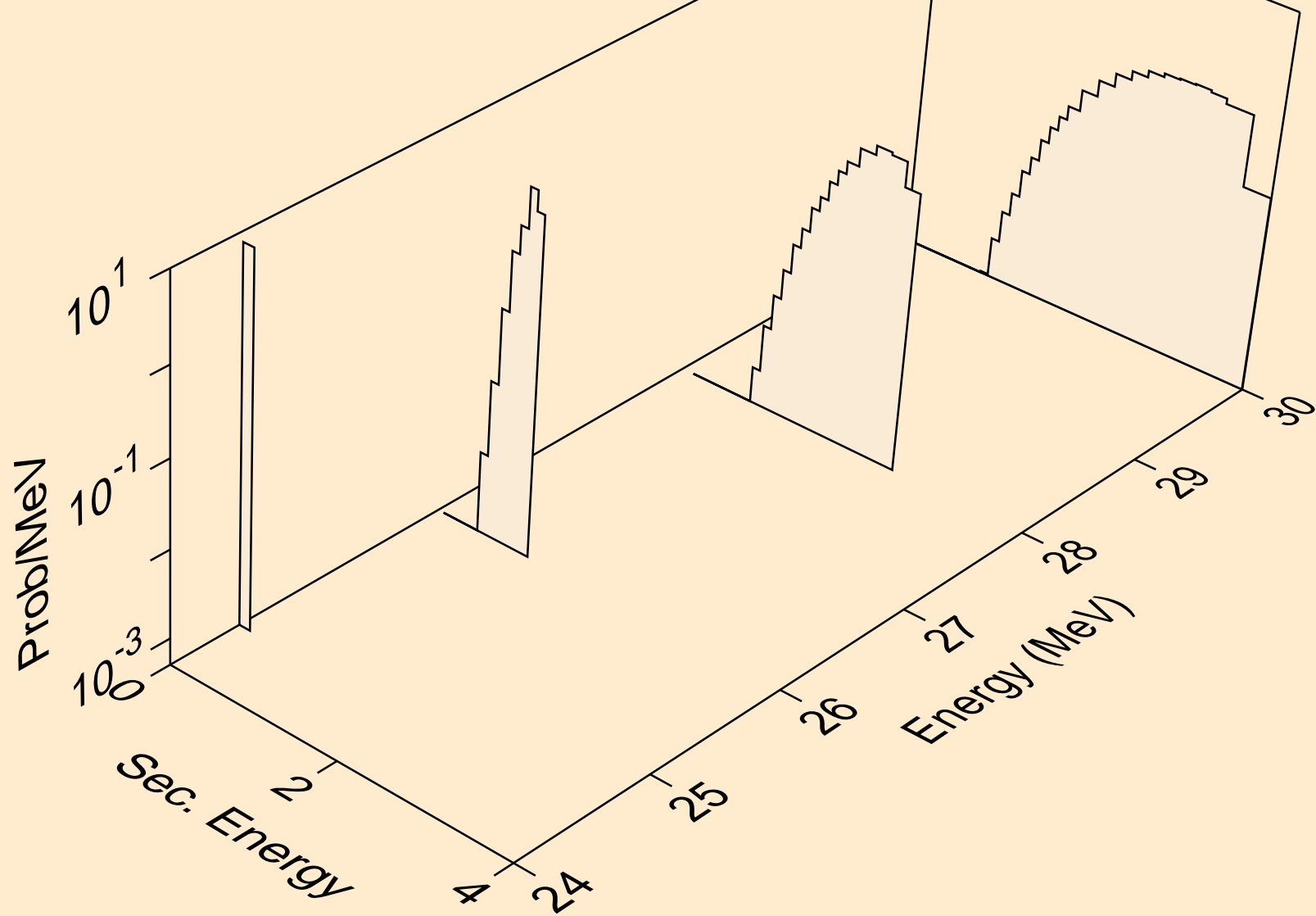

O021 ALPHA ACER TENDL-2024 LIBRARY; T=0.K
he3s from (a,he3)

