

RH104M ALPHA ACER TENDL-2024 LIBRARY; T=0.K  
Principal cross sections

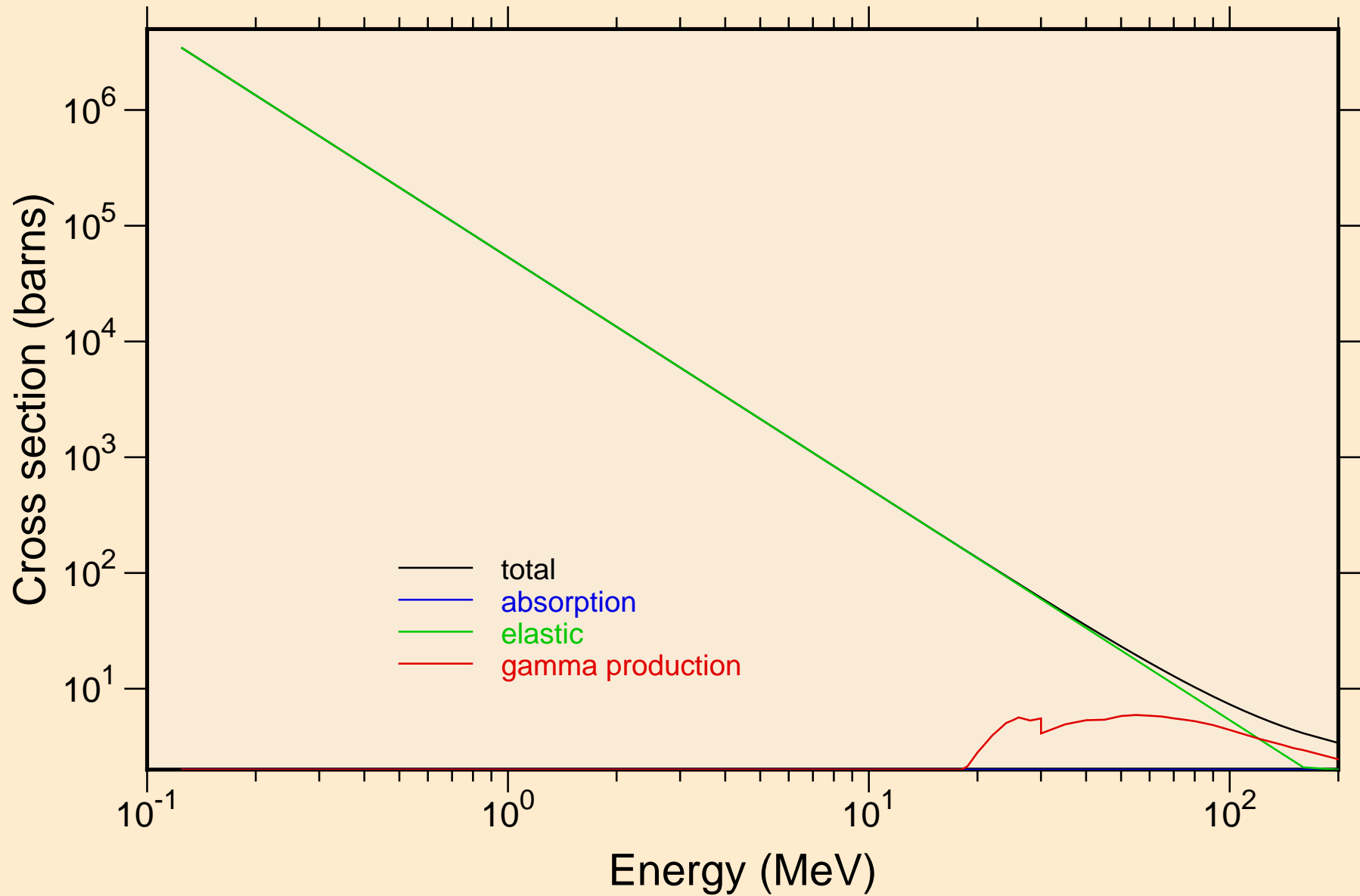

# RH104M ALPHA ACER TENDL-2024 LIBRARY; T=0.K

## Heating

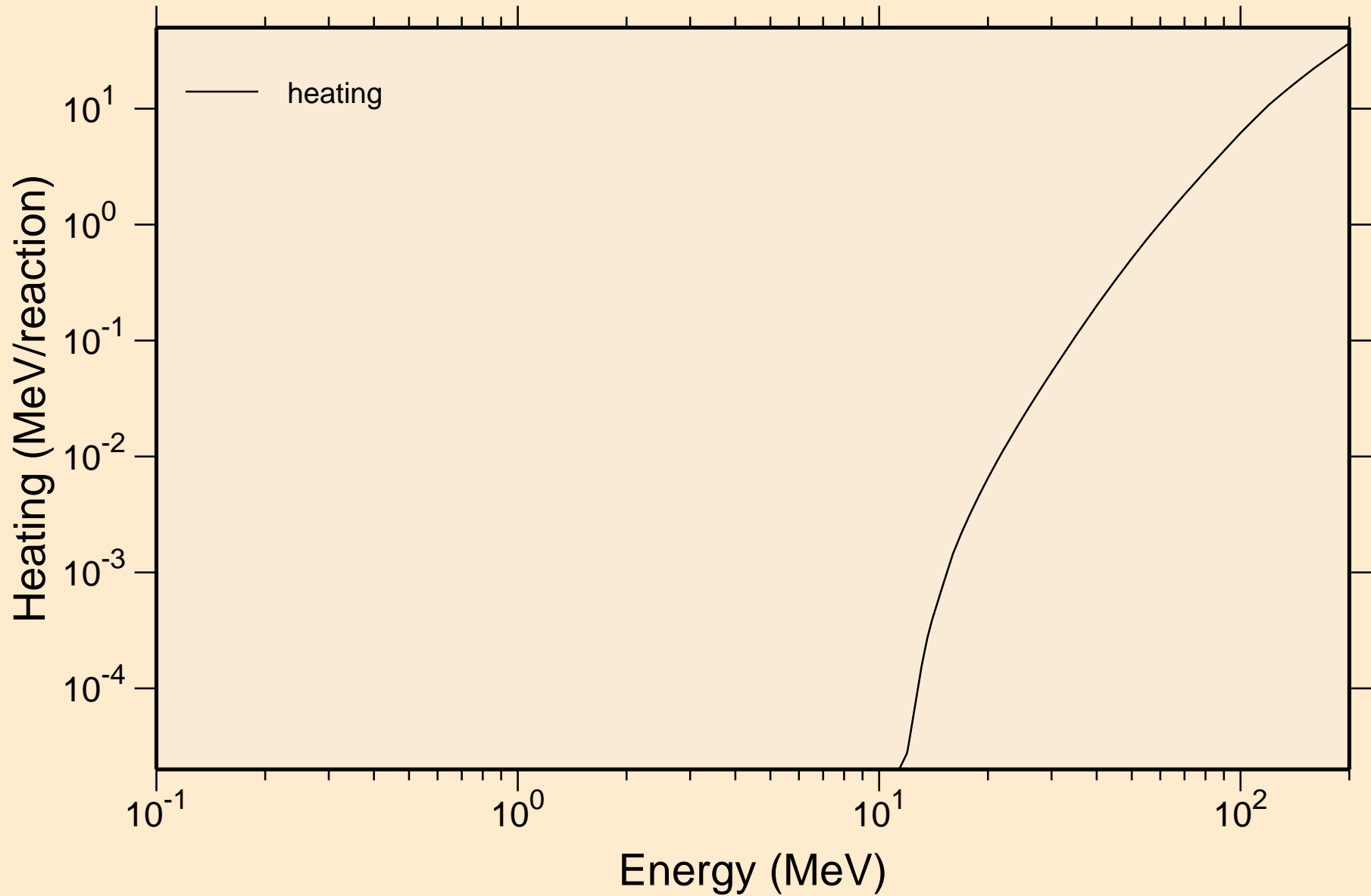

# RH104M ALPHA ACER TENDL-2024 LIBRARY; T=0.K

## Principal cross sections

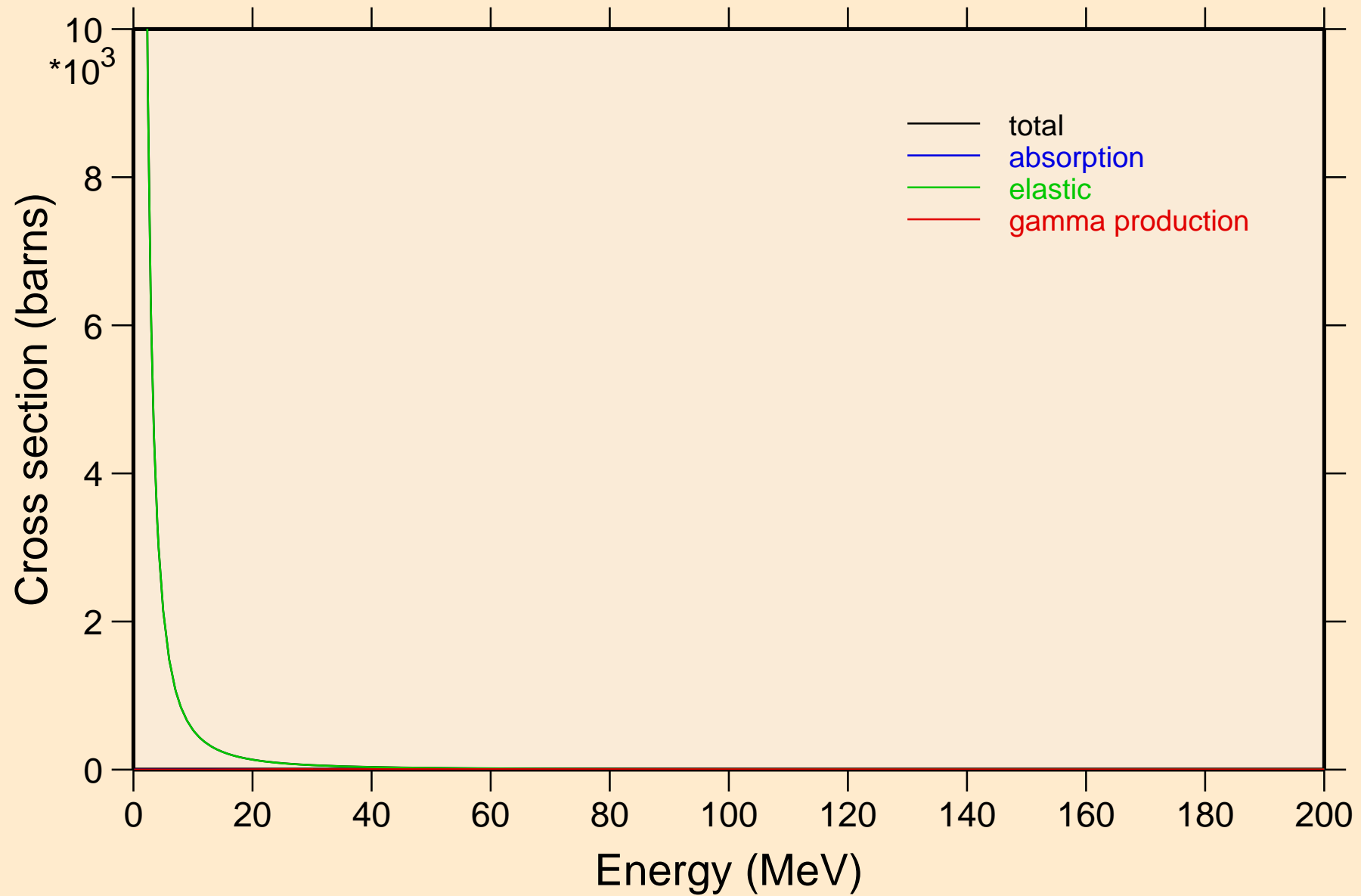

RH104M ALPHA ACER TENDL-2024 LIBRARY; T=0.K

Heating

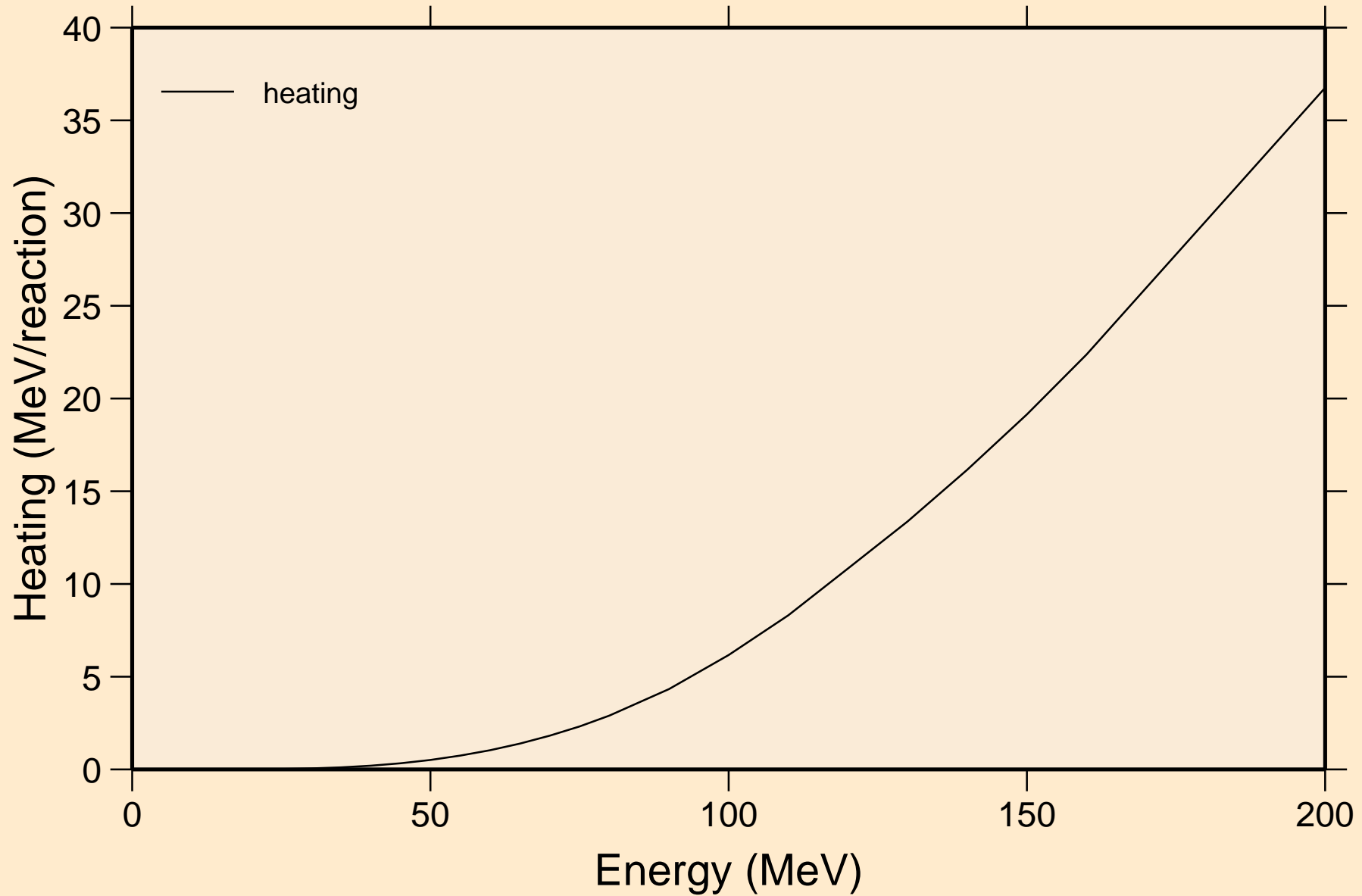

RH104M ALPHA ACER TENDL-2024 LIBRARY; T=0.K  
Threshold reactions

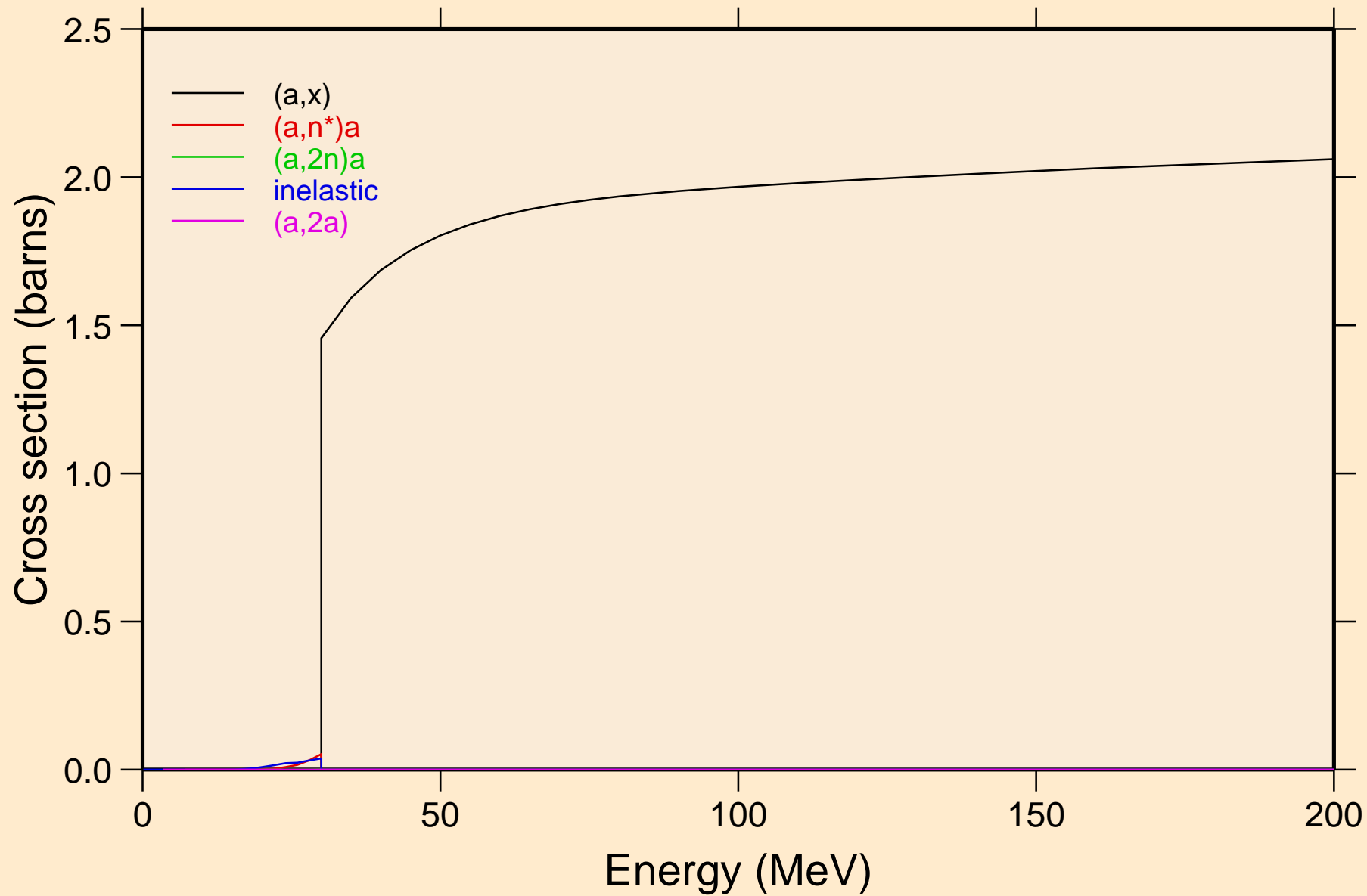

RH104M ALPHA ACER TENDL-2024 LIBRARY; T=0.K  
Threshold reactions

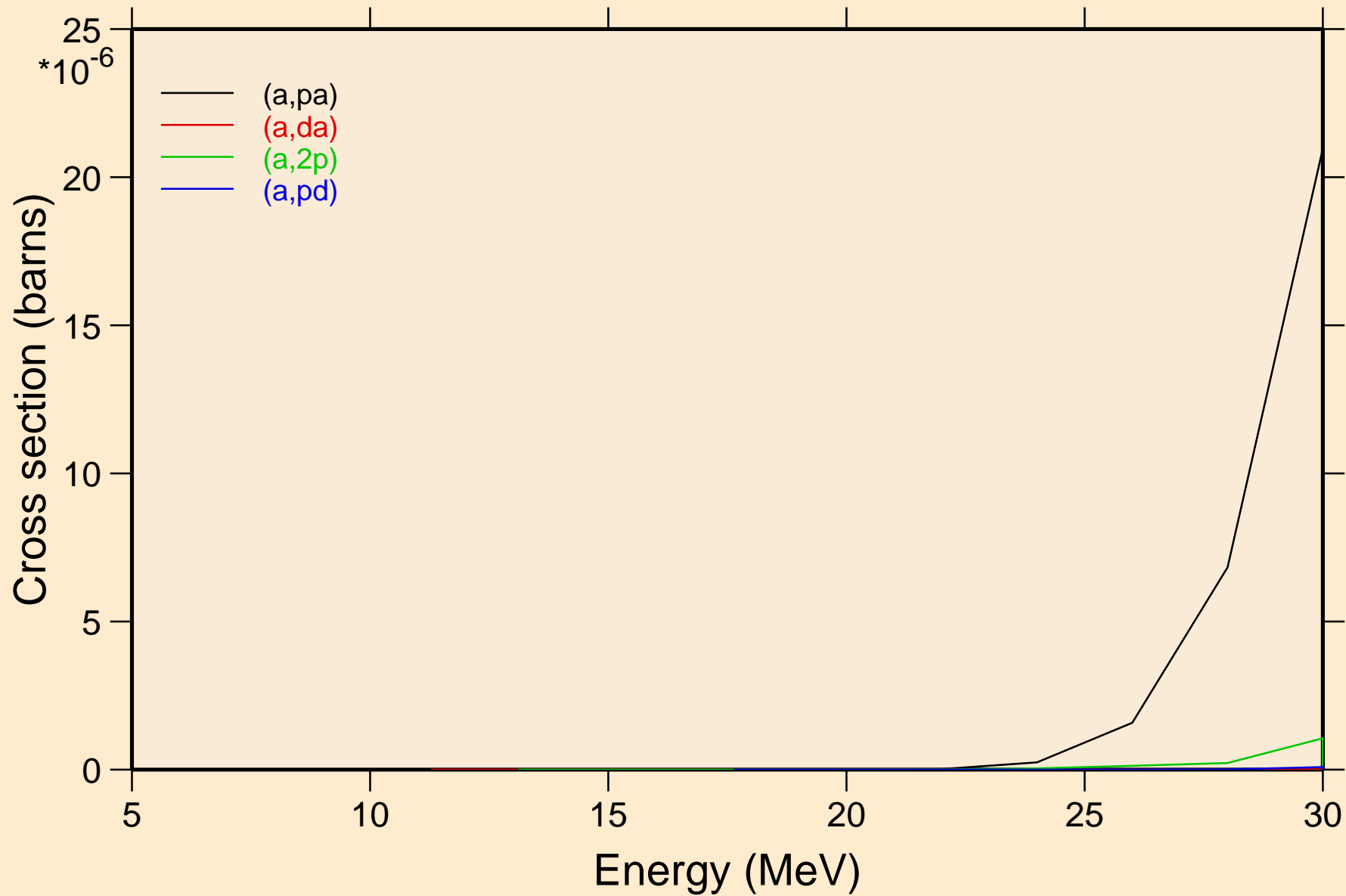

RH104M ALPHA ACER TENDL-2024 LIBRARY; T=0.K  
Threshold reactions

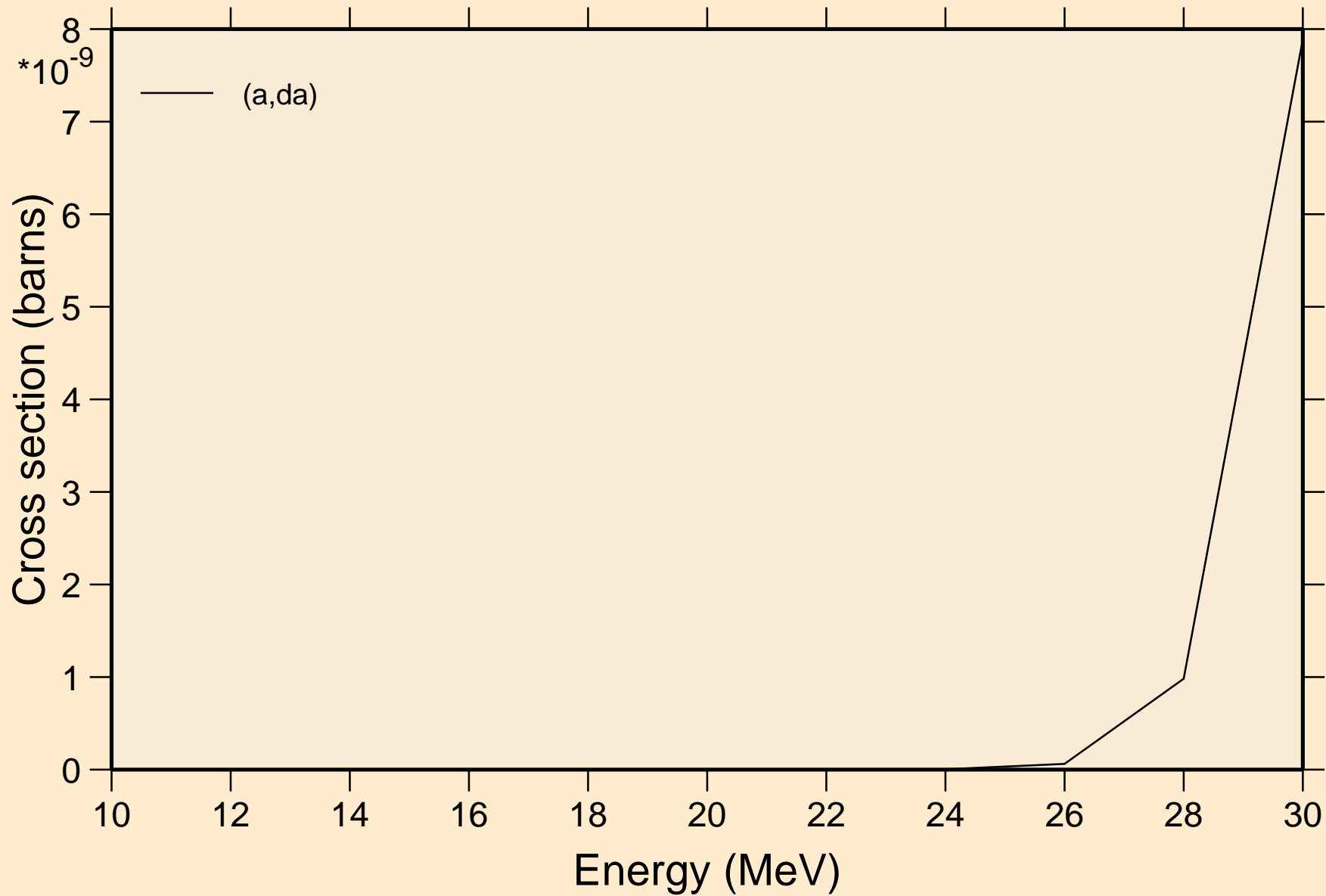

RH104M ALPHA ACER TENDL-2024 LIBRARY; T=0.K  
angular distribution for elastic

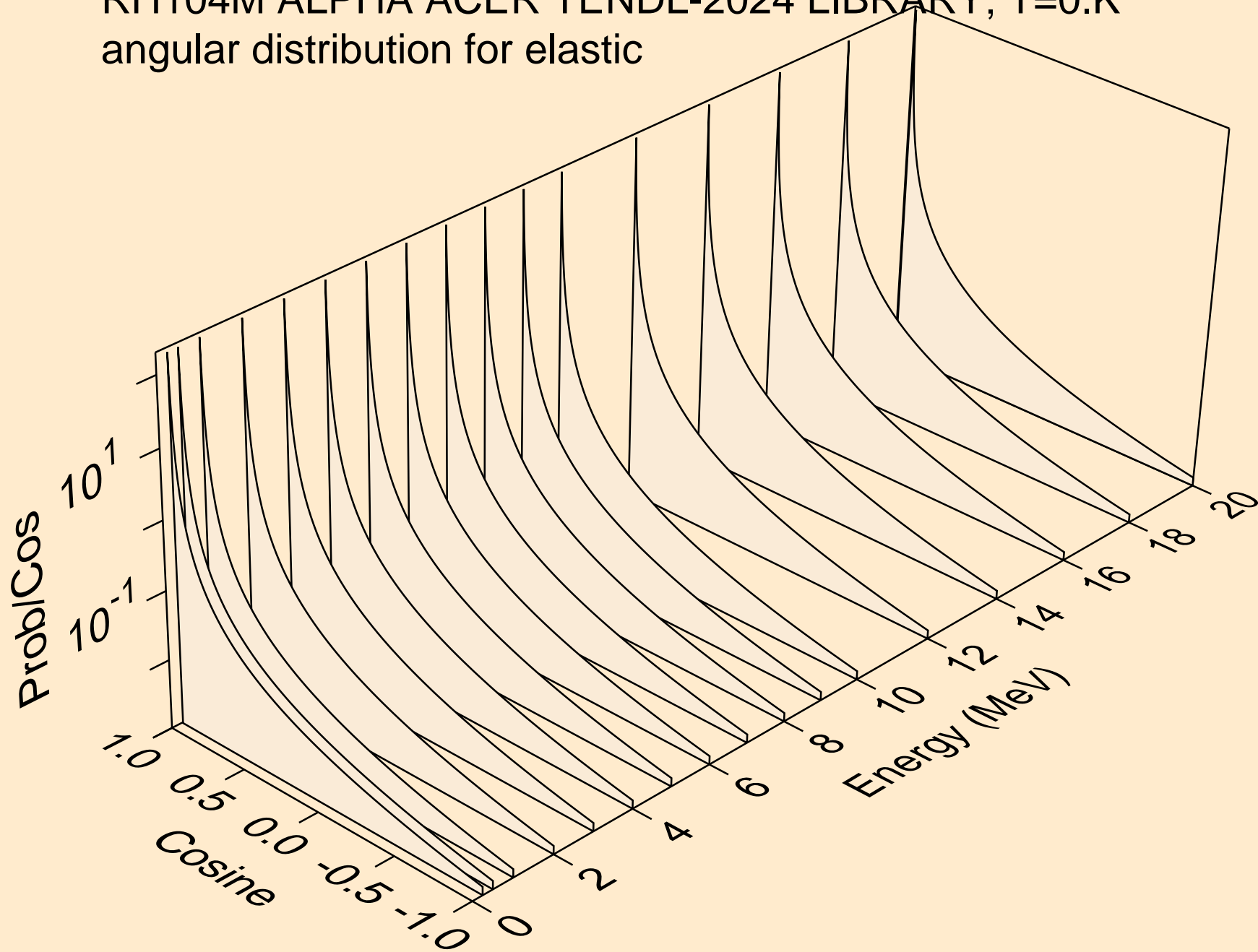

RH104M ALPHA ACER TENDL-2024 LIBRARY; T=0.K  
angular distribution for elastic

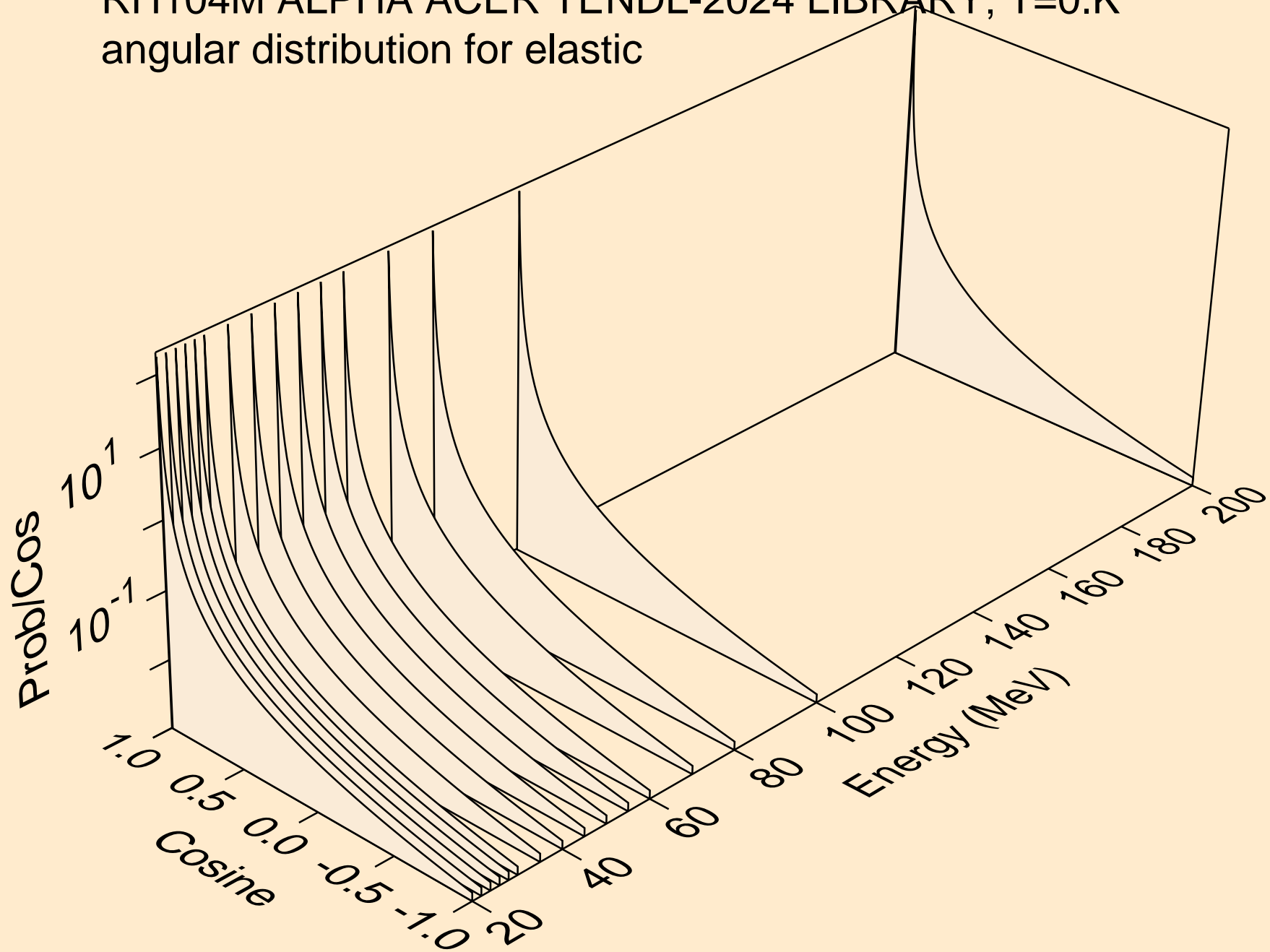

RH104M ALPHA ACER TENDL-2024 LIBRARY; T=0.K  
Alpha emission for (a,x)

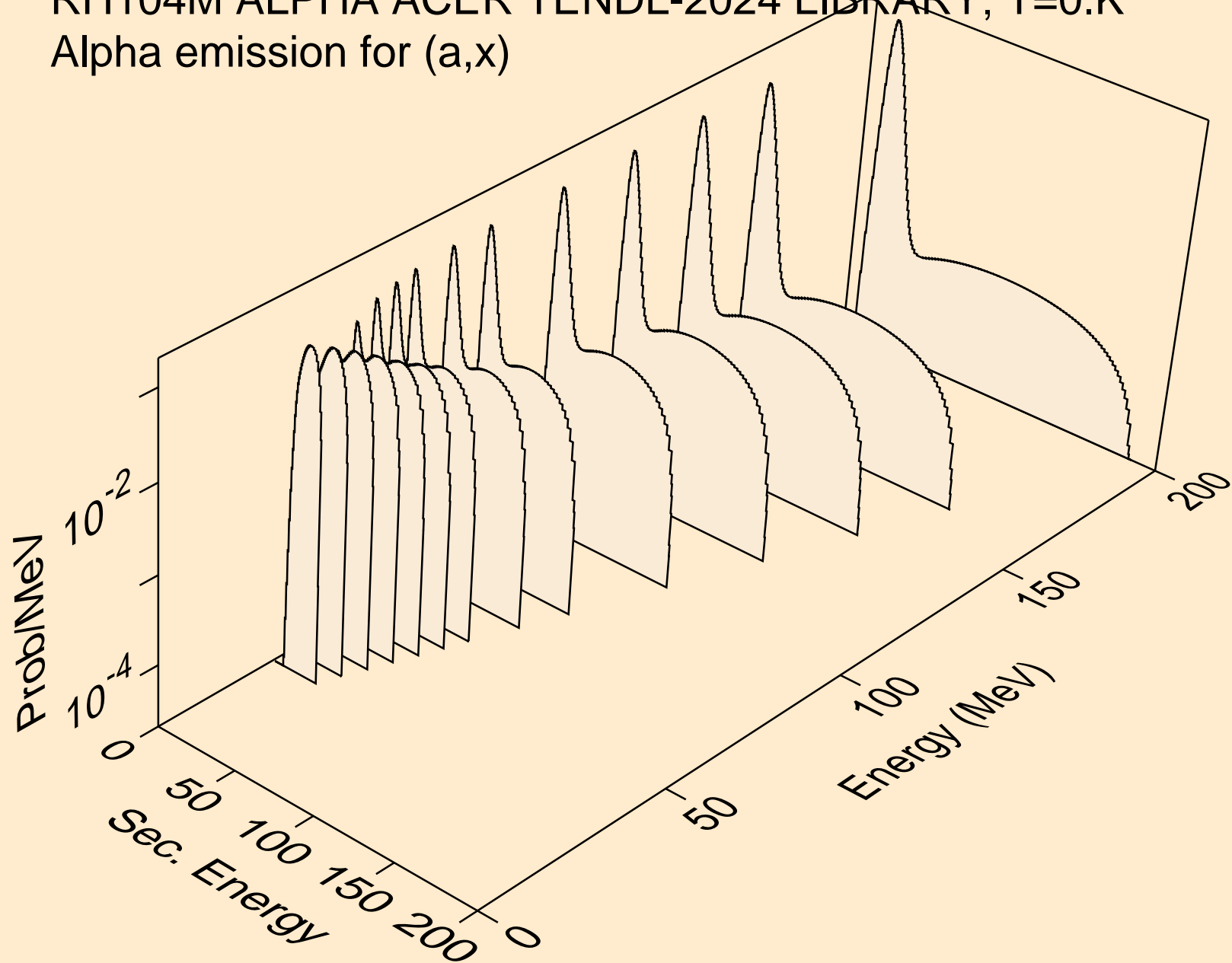

RH104M ALPHA ACER TENDL-2024 LIBRARY; T=0.K  
Alpha emission for (a,n\*)a

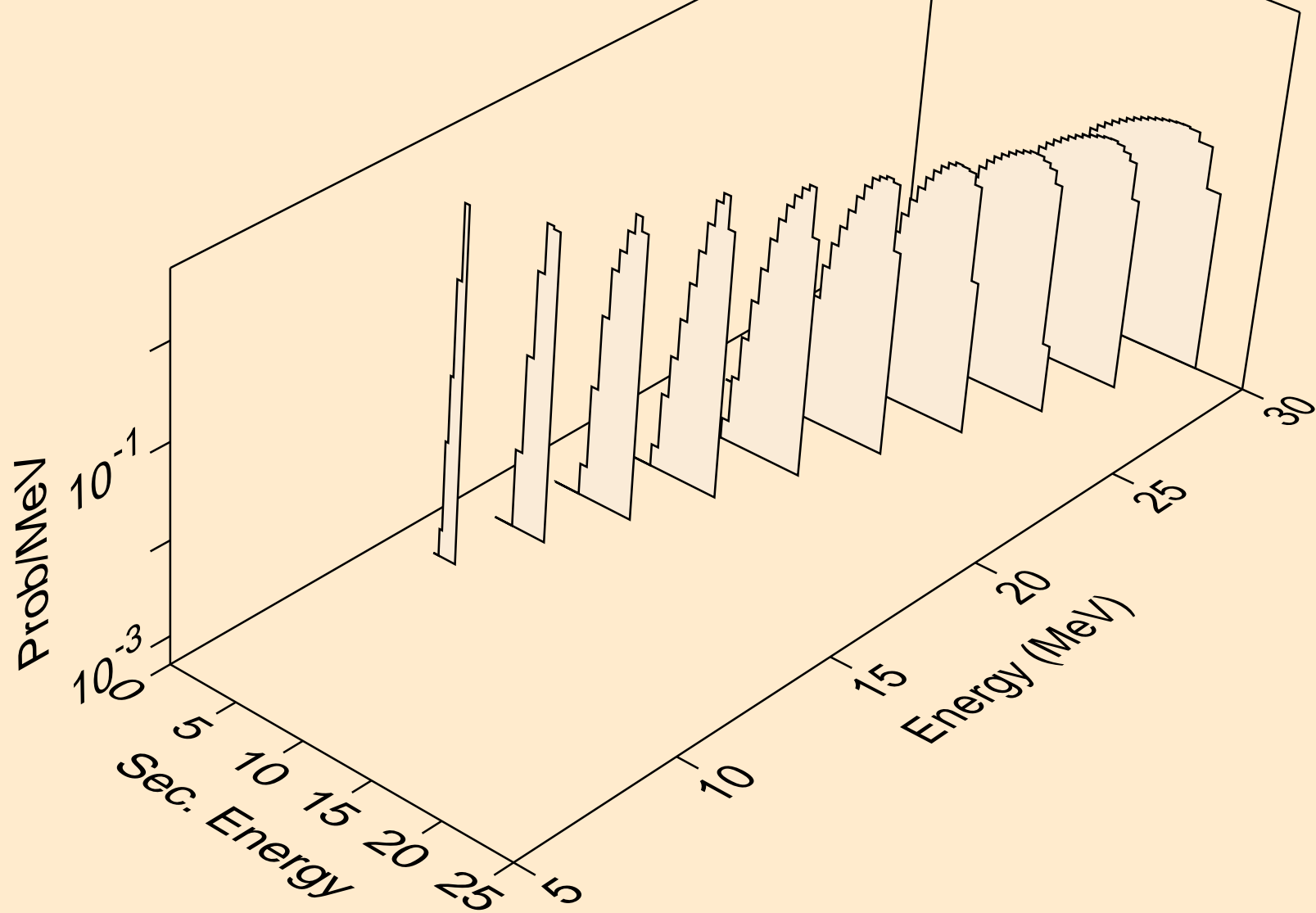

RH104M ALPHA ACER TENDL-2024 LIBRARY; T=0.K  
Alpha emission for (a,2n)a

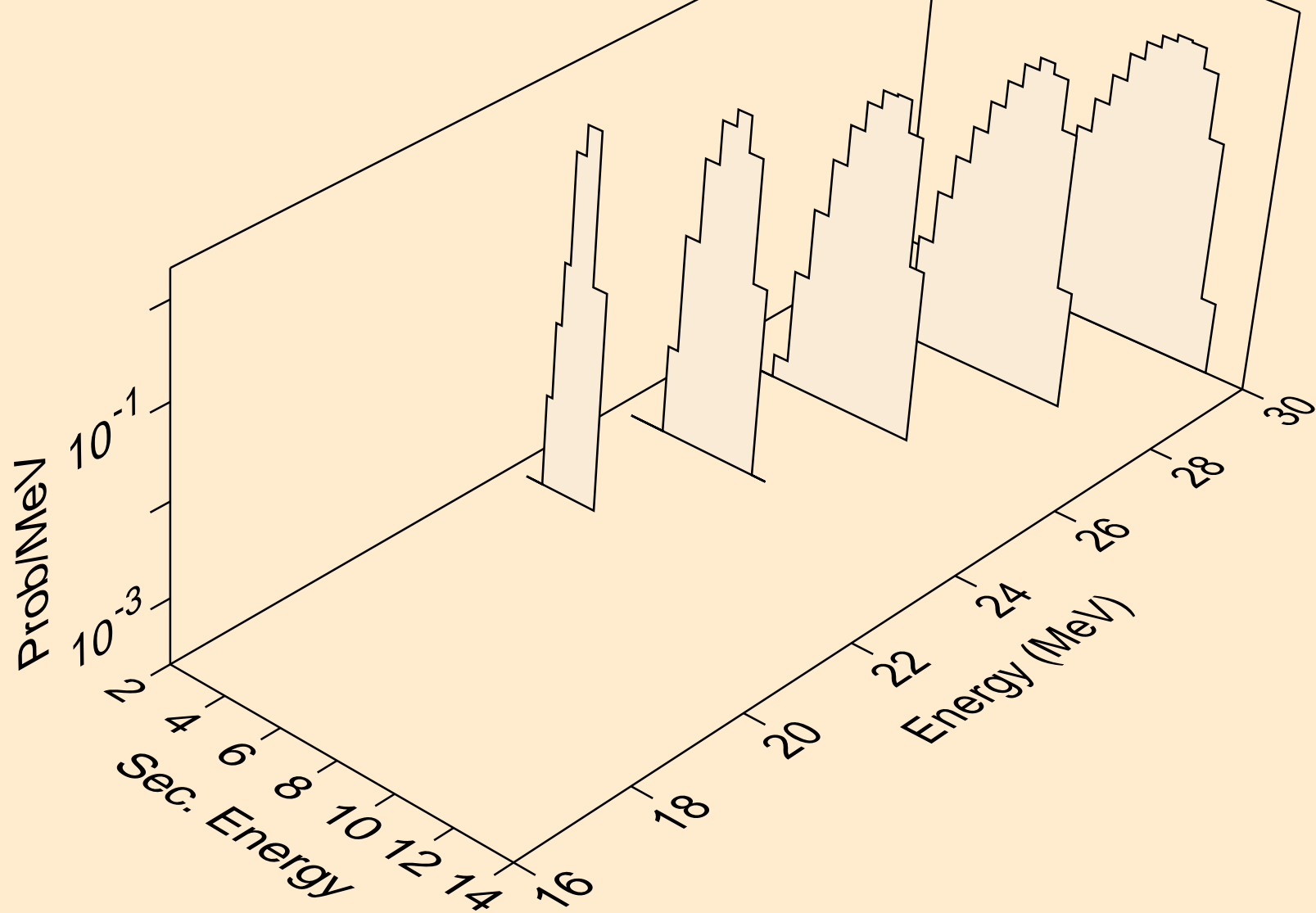

RH104M ALPHA ACER TENDL-2024 LIBRARY; T=0.K  
Alpha emission for inelastic

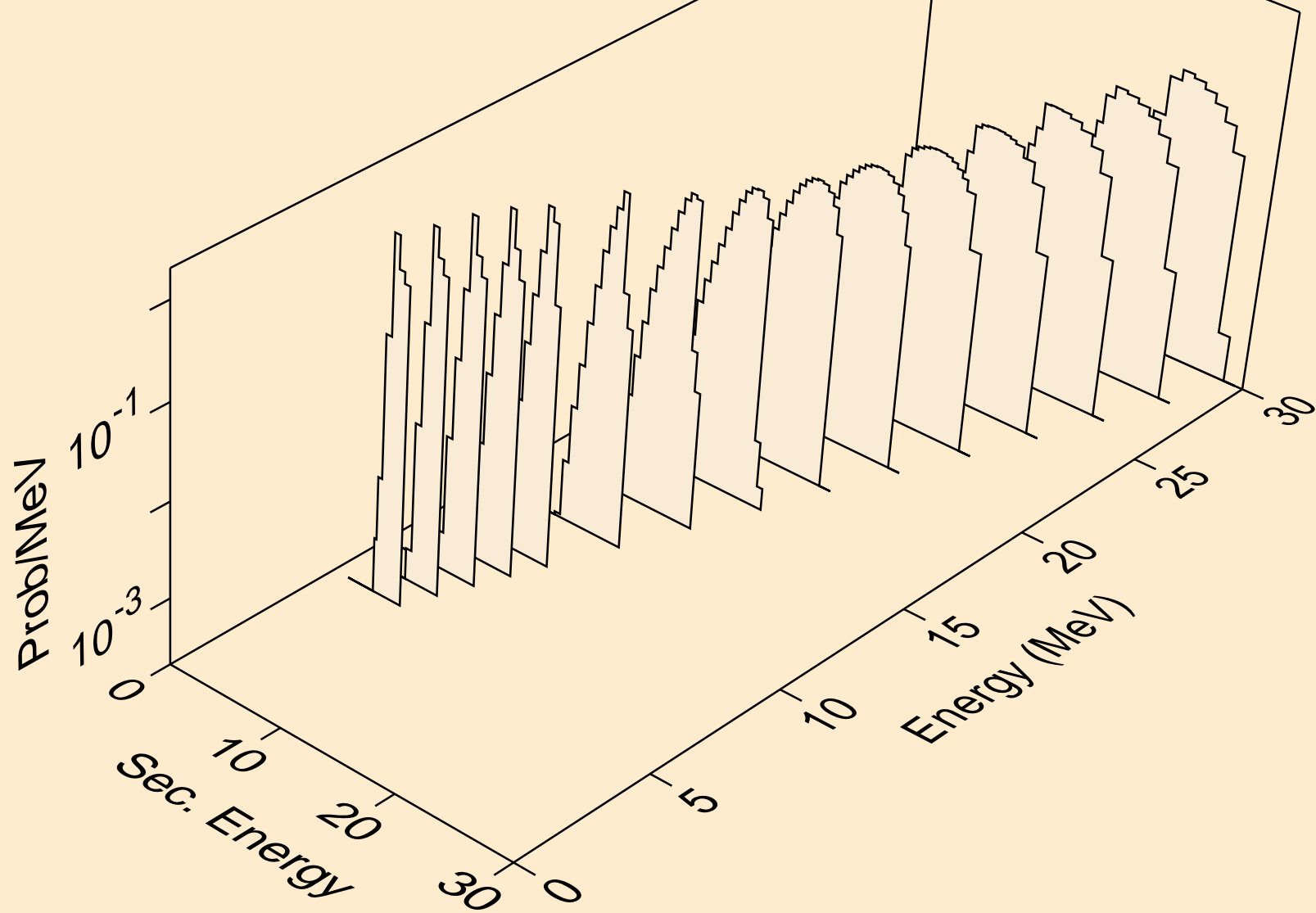

RH104M ALPHA ACER TENDL-2024 LIBRARY; T=0.K  
Alpha emission for (a,2a)

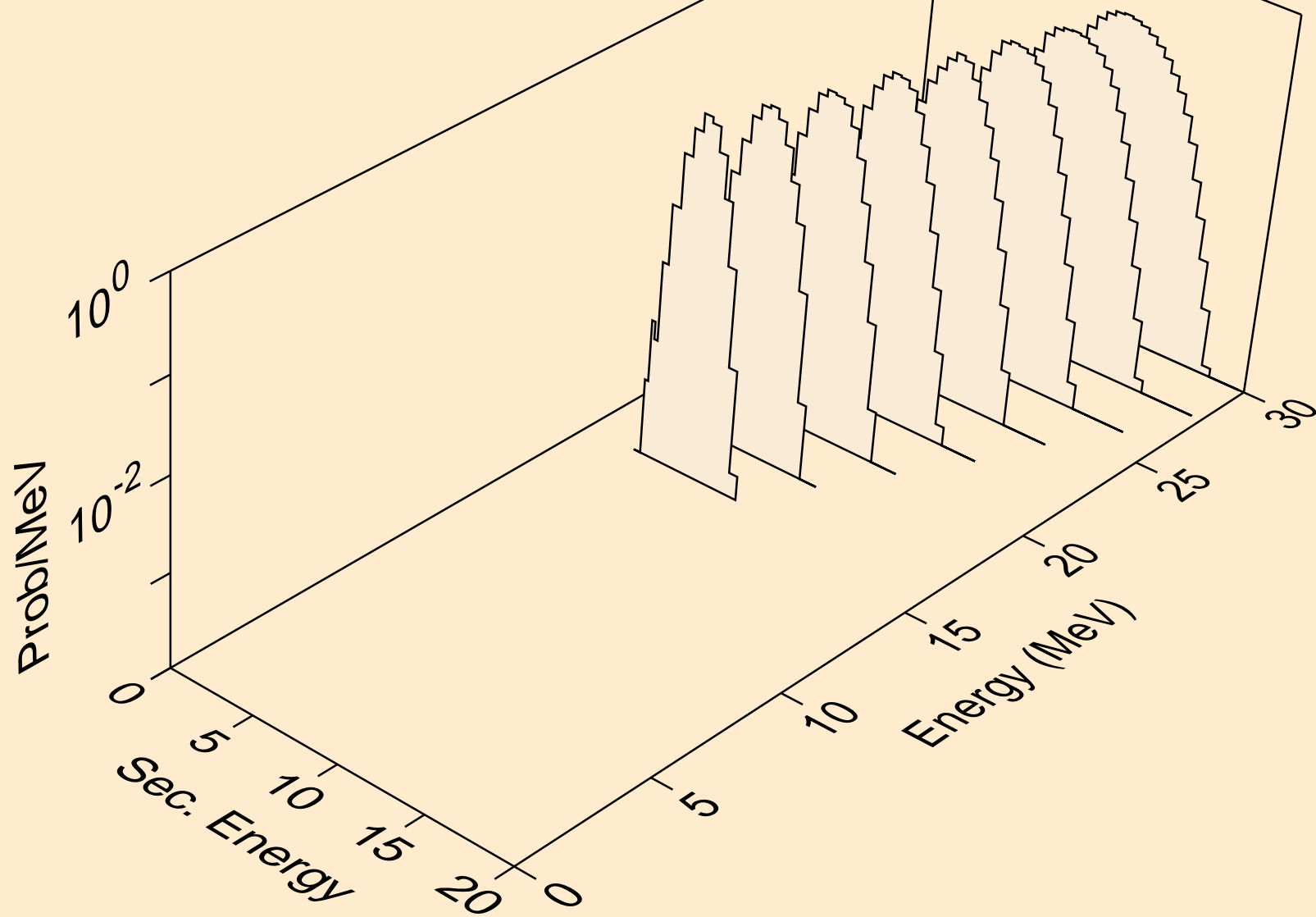

RH104M ALPHA ACER TENDL-2024 LIBRARY; T=0.K  
Alpha emission for (a,pa)

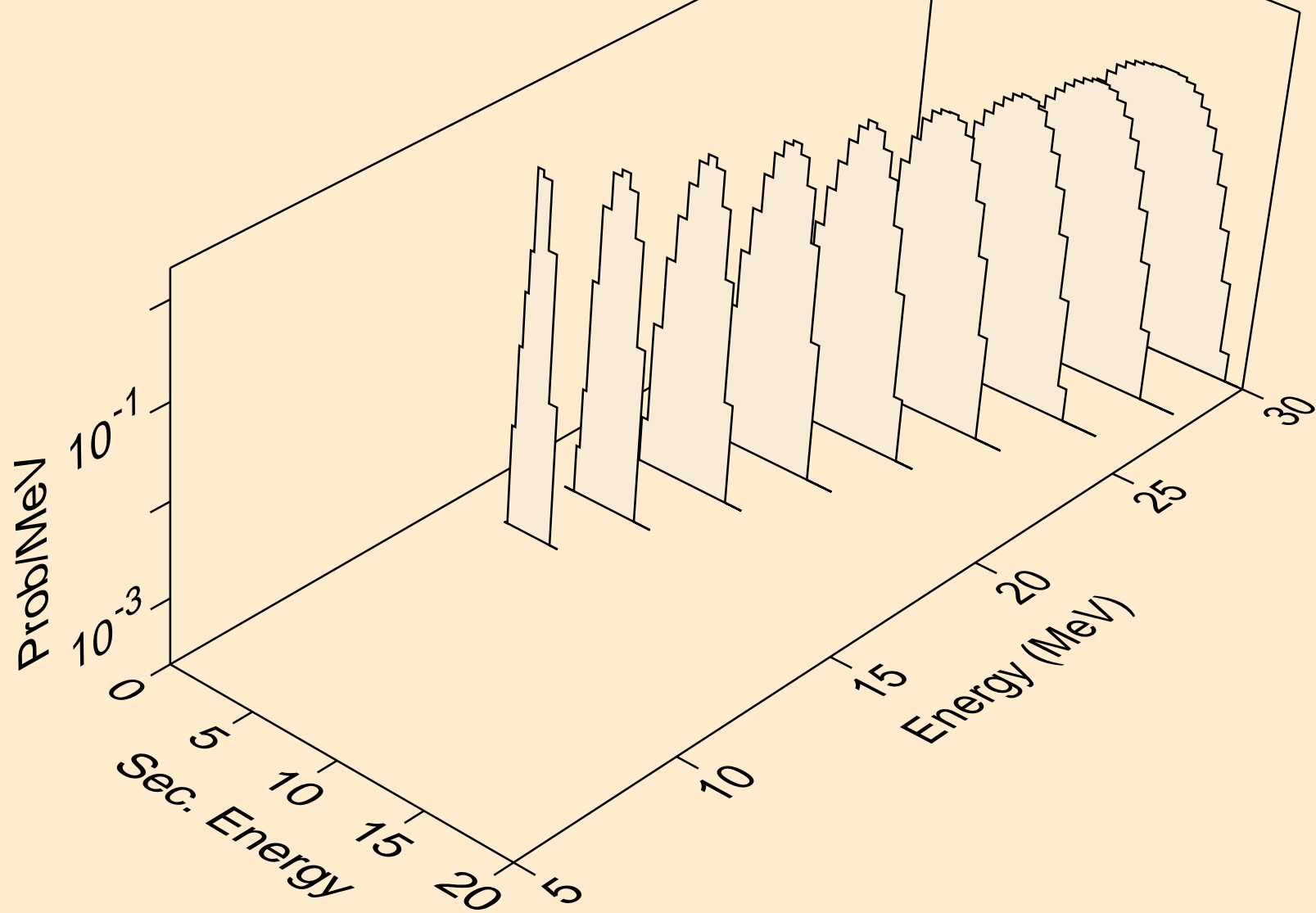

RH104M ALPHA ACER TENDL-2024 LIBRARY; T=0.K  
Alpha emission for (a,da)

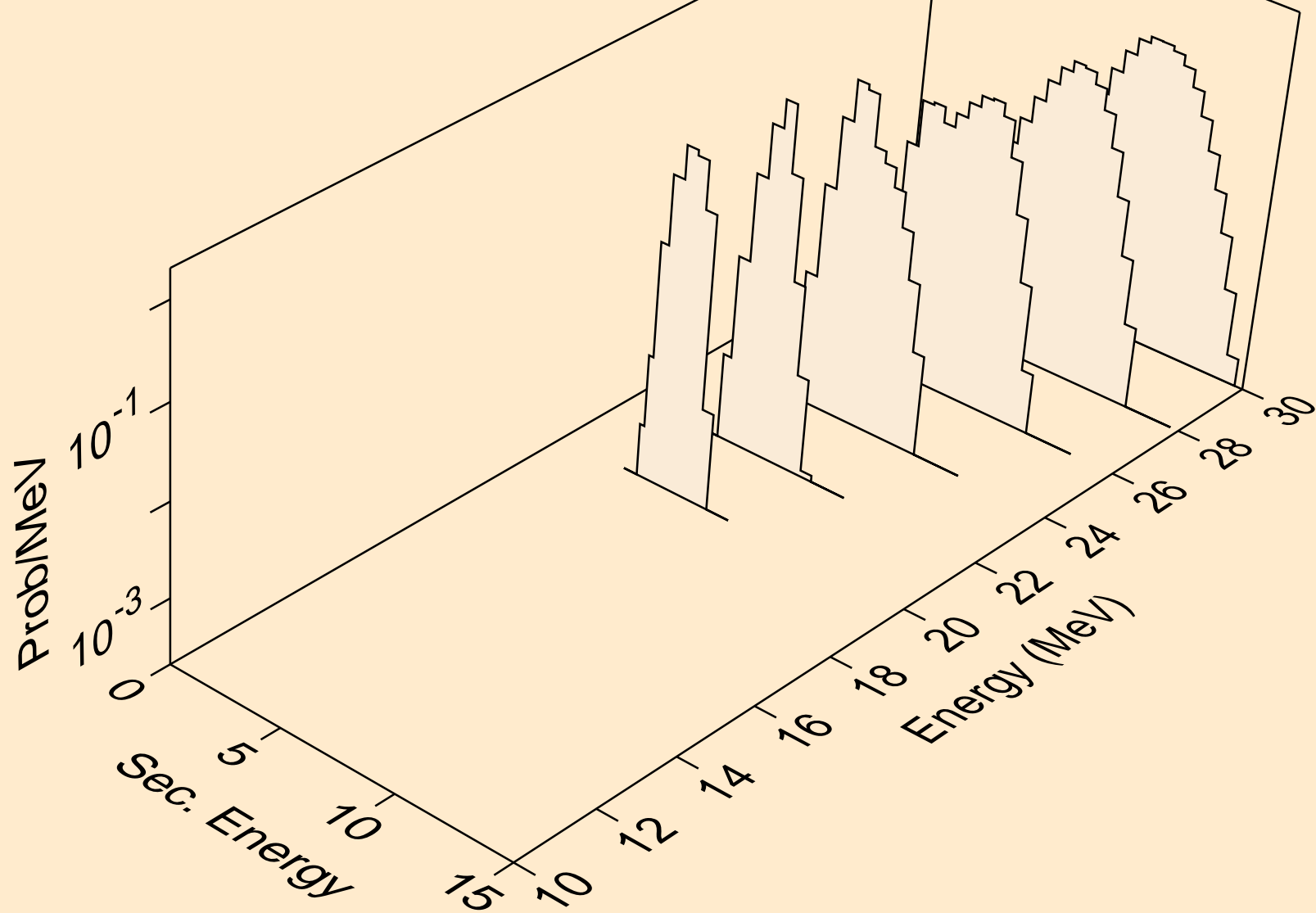

RH104M ALPHA ACER TENDL-2024 LIBRARY; T=0.K  
Photon emission for (z,n)

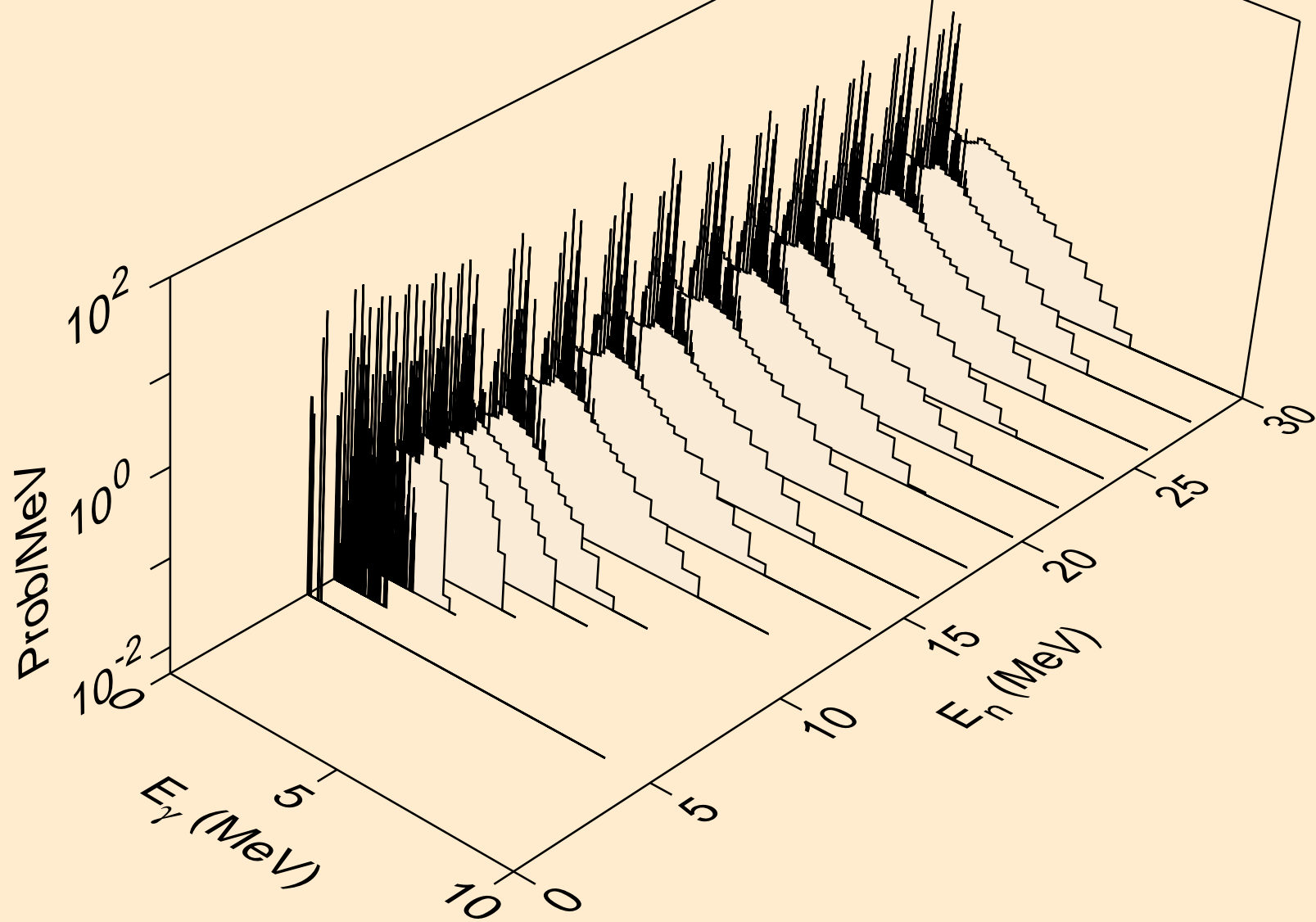

RH104M ALPHA ACER TENDL-2024 LIBRARY; T=0.K  
Photon emission for (z,x)

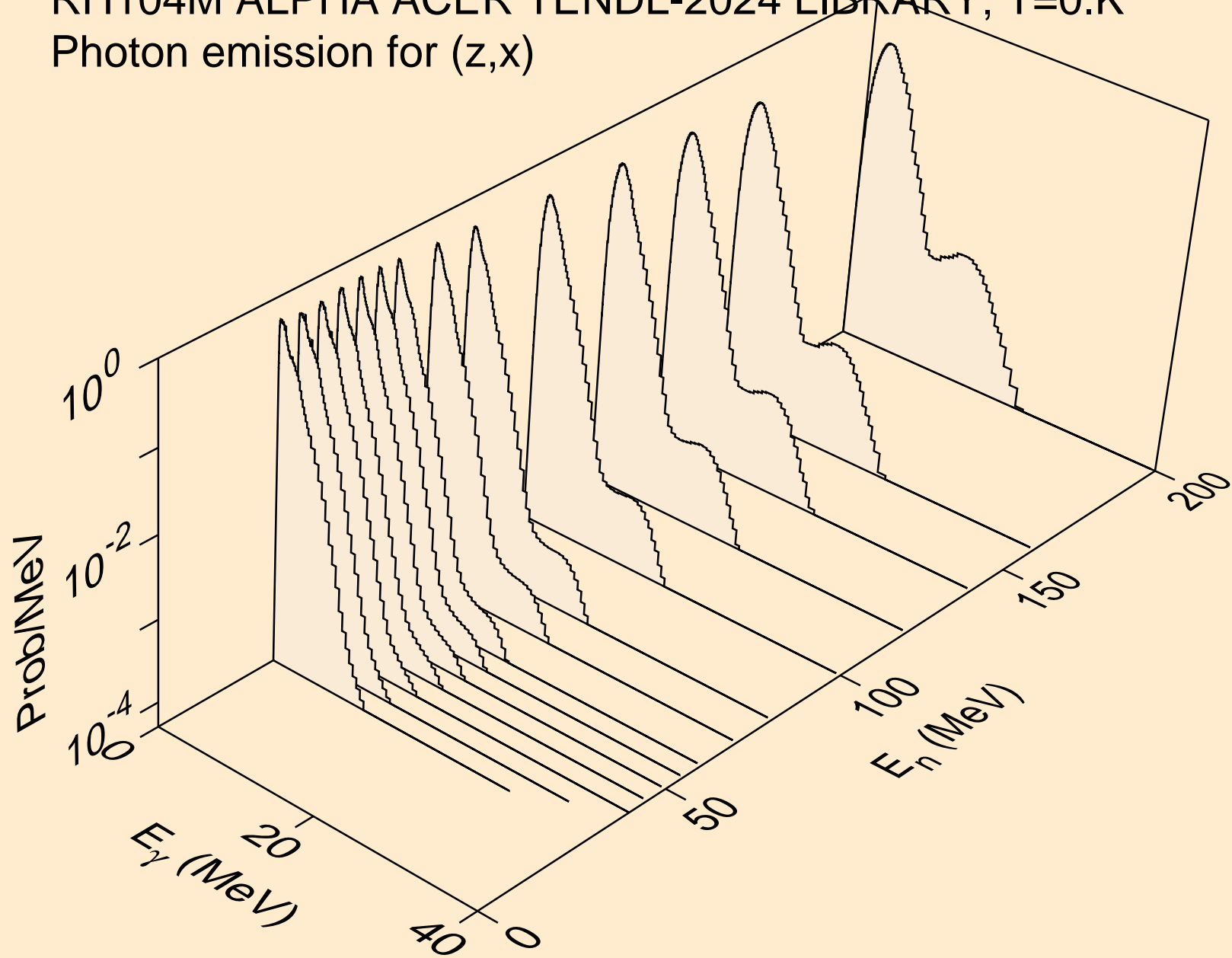

RH104M ALPHA ACER TENDL-2024 LIBRARY; T=0.K  
Photon emission for (n,2nd)

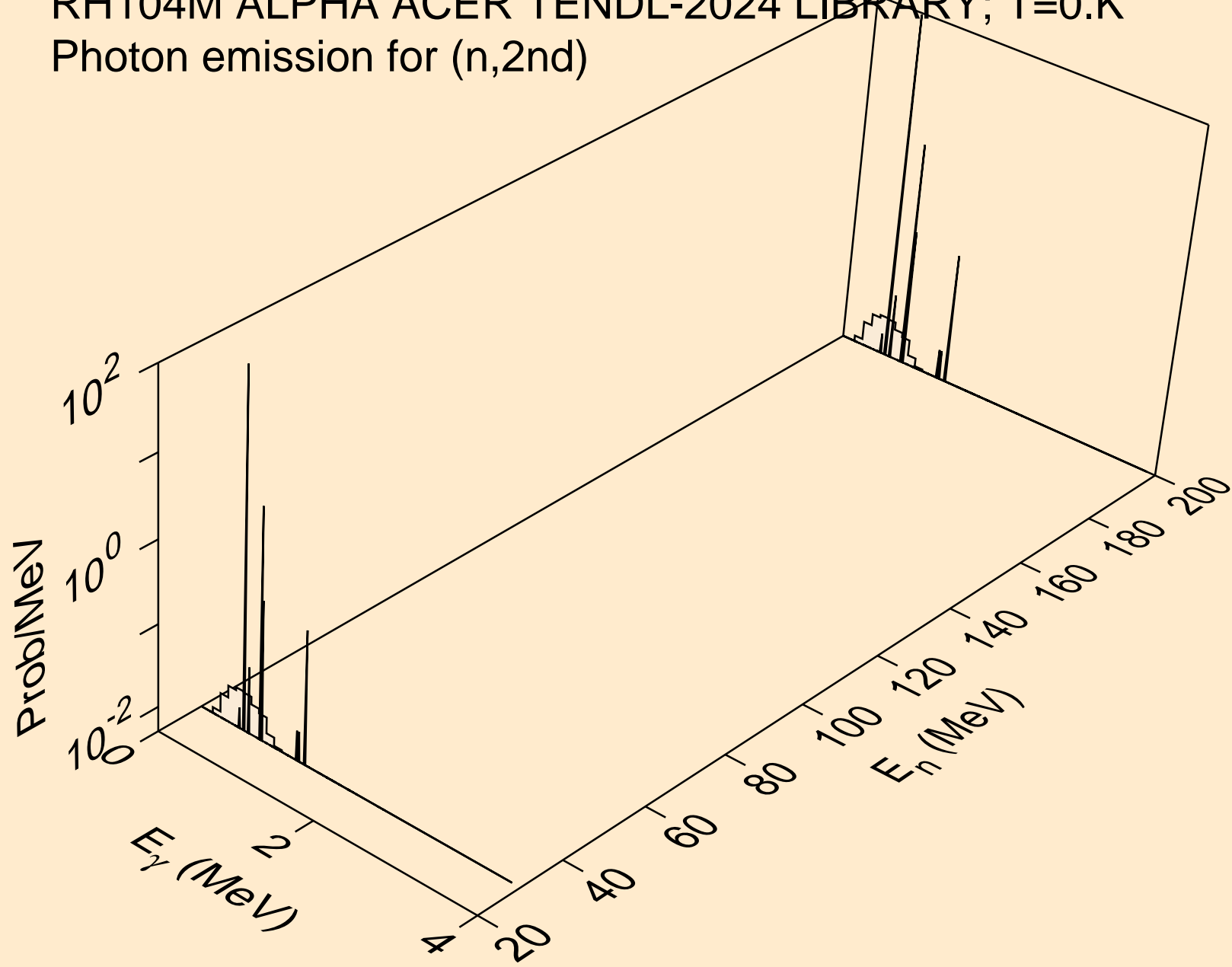

RH104M ALPHA ACER TENDL-2024 LIBRARY; T=0.K  
Photon emission for (n,2n)

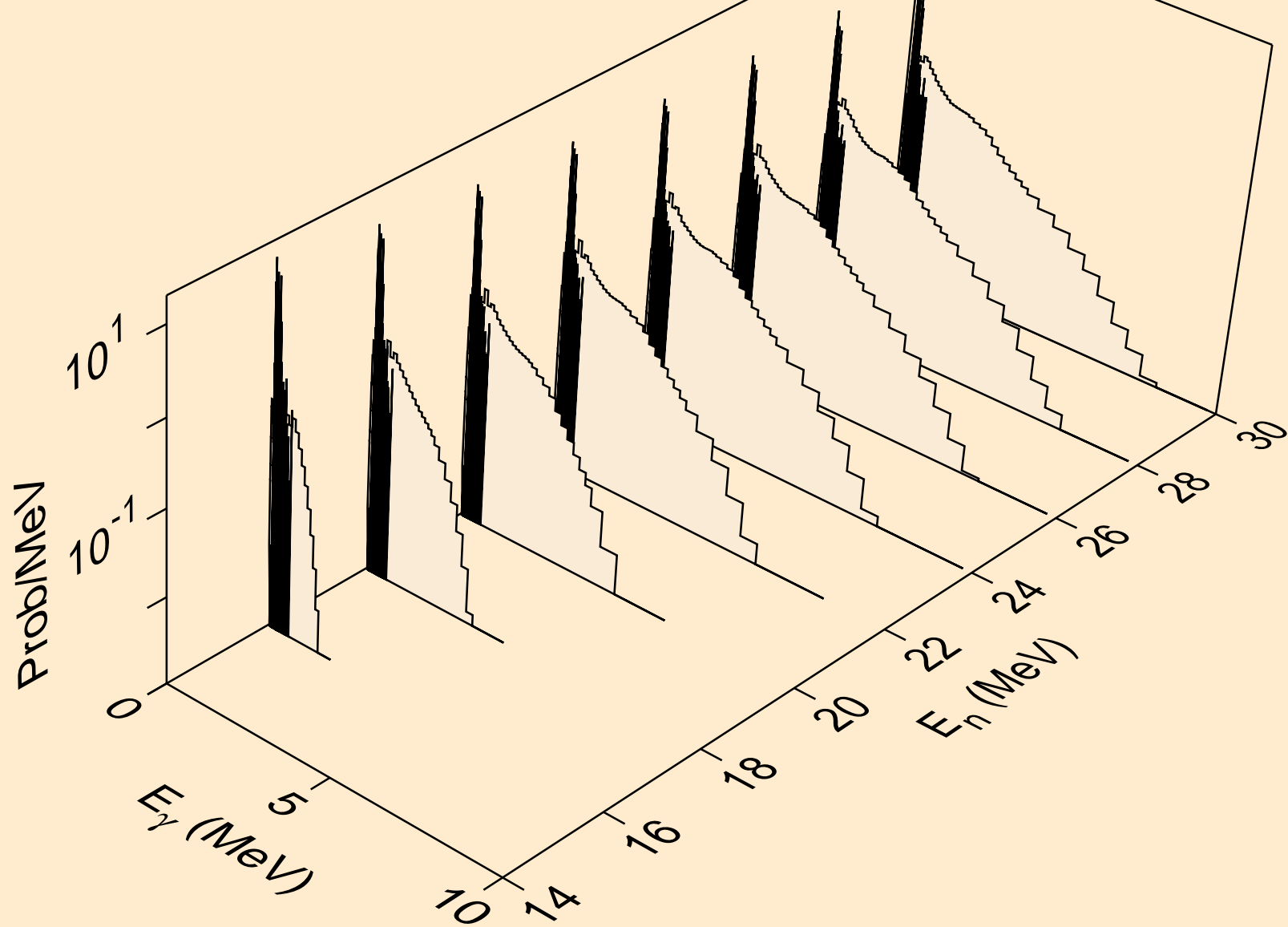

RH104M ALPHA ACER TENDL-2024 LIBRARY; T=0.K  
Photon emission for (n,3n)

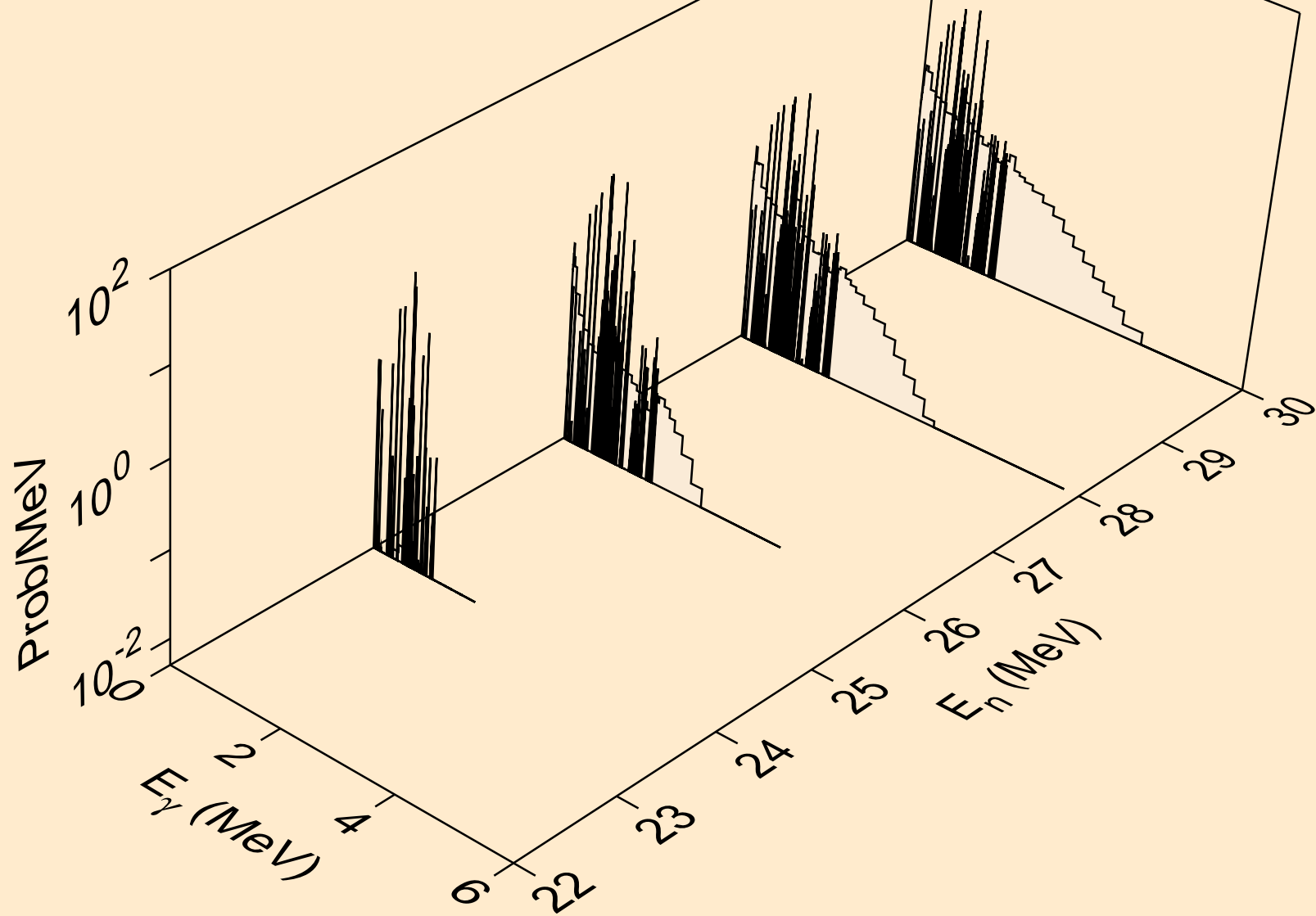

RH104M ALPHA ACER TENDL-2024 LIBRARY; T=0.K  
Photon emission for (n,n\*)a

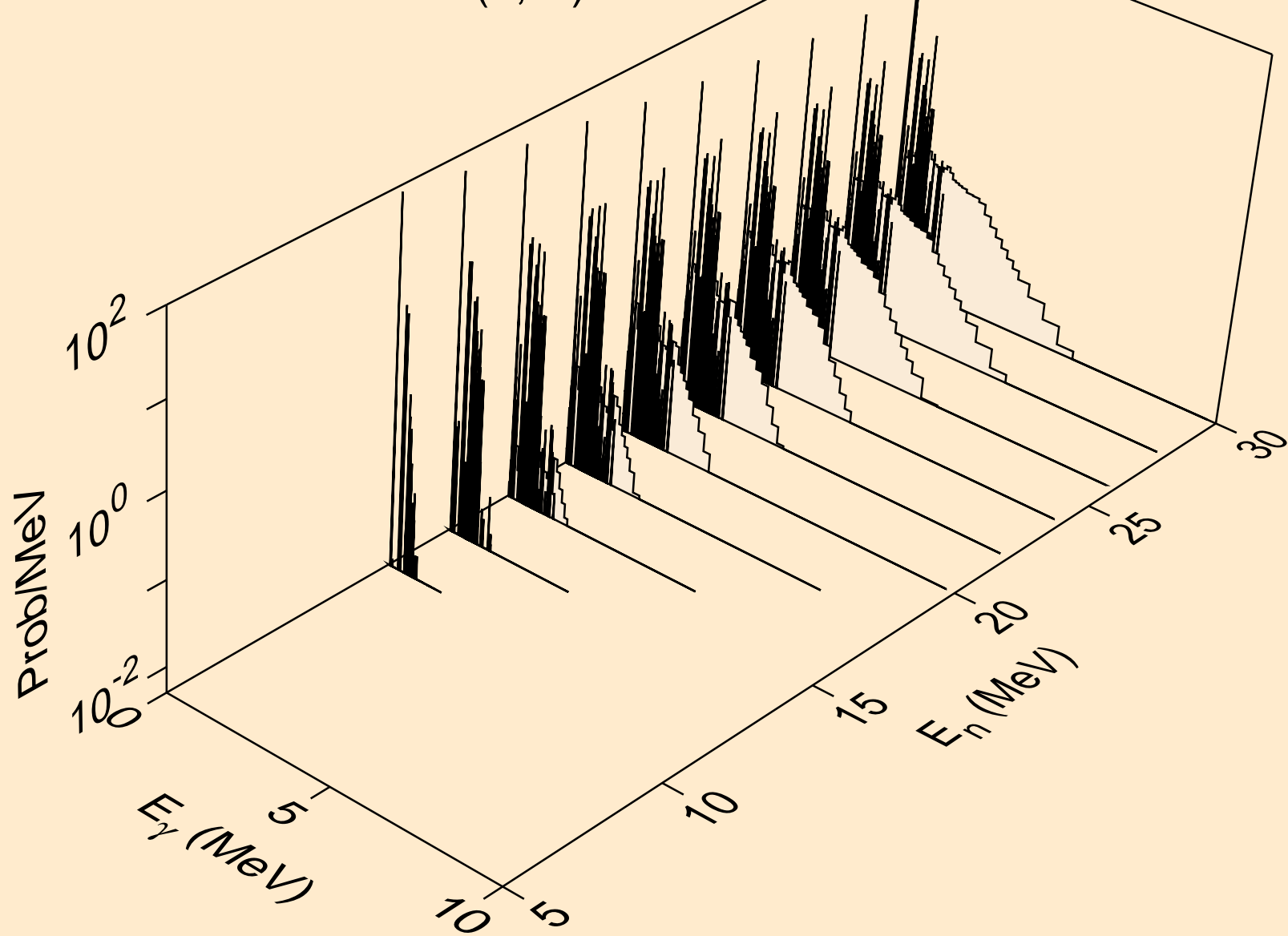

RH104M ALPHA ACER TENDL-2024 LIBRARY; T=0.K  
Photon emission for (n,2n)a

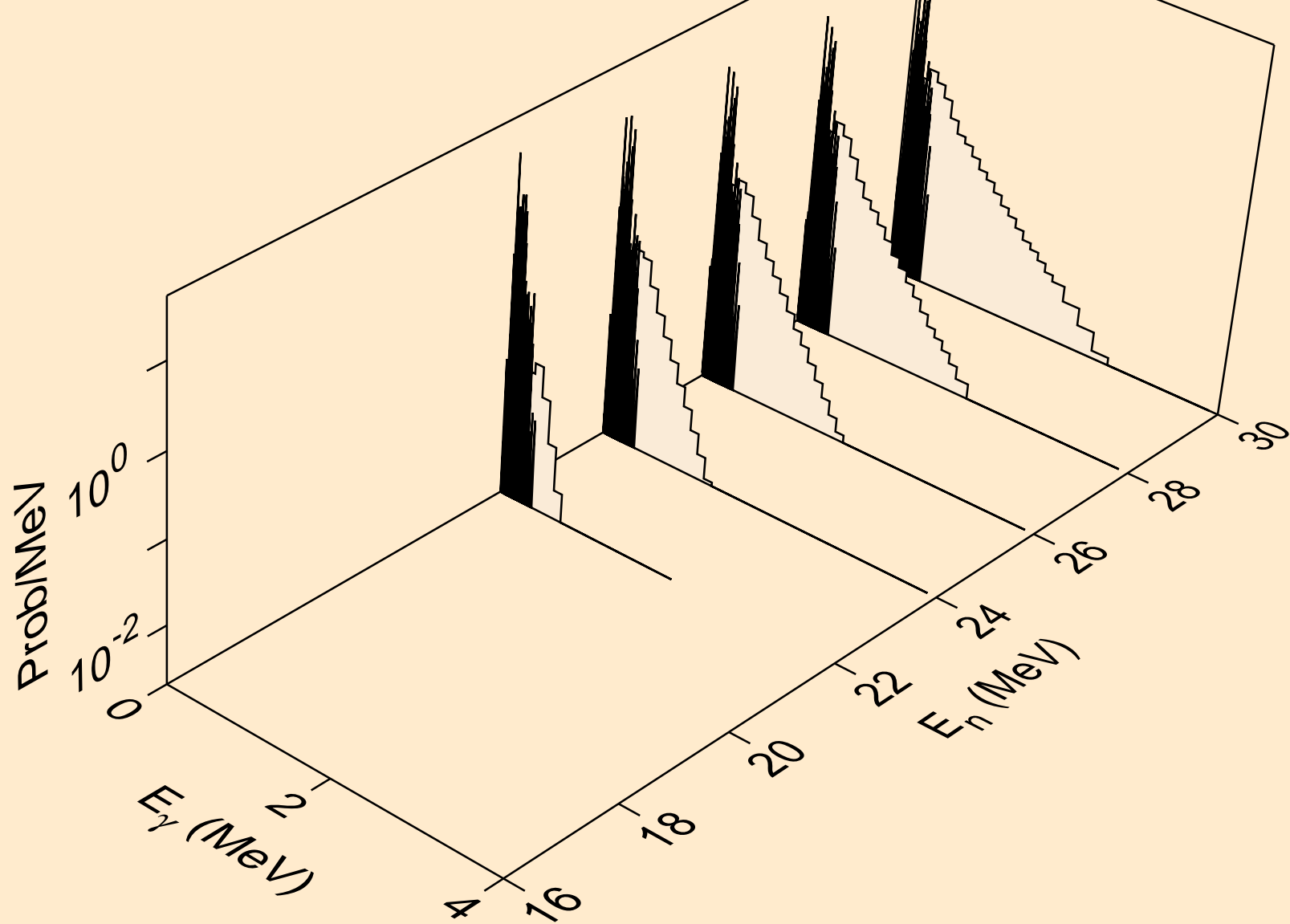

RH104M ALPHA ACER TENDL-2024 LIBRARY; T=0.K  
Photon emission for (n,n\*)p

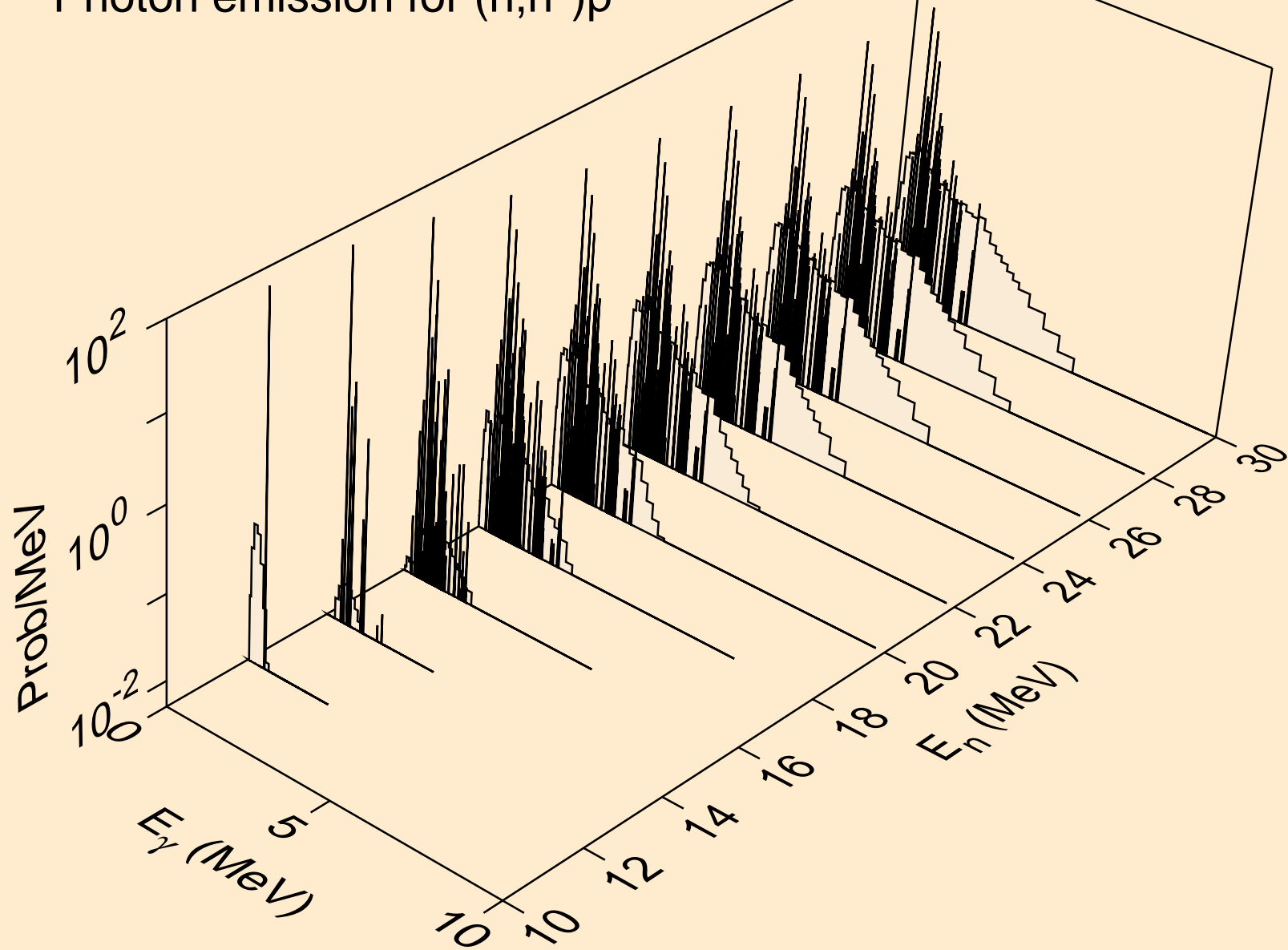

RH104M ALPHA ACER TENDL-2024 LIBRARY; T=0.K  
Photon emission for (n,n\*)d

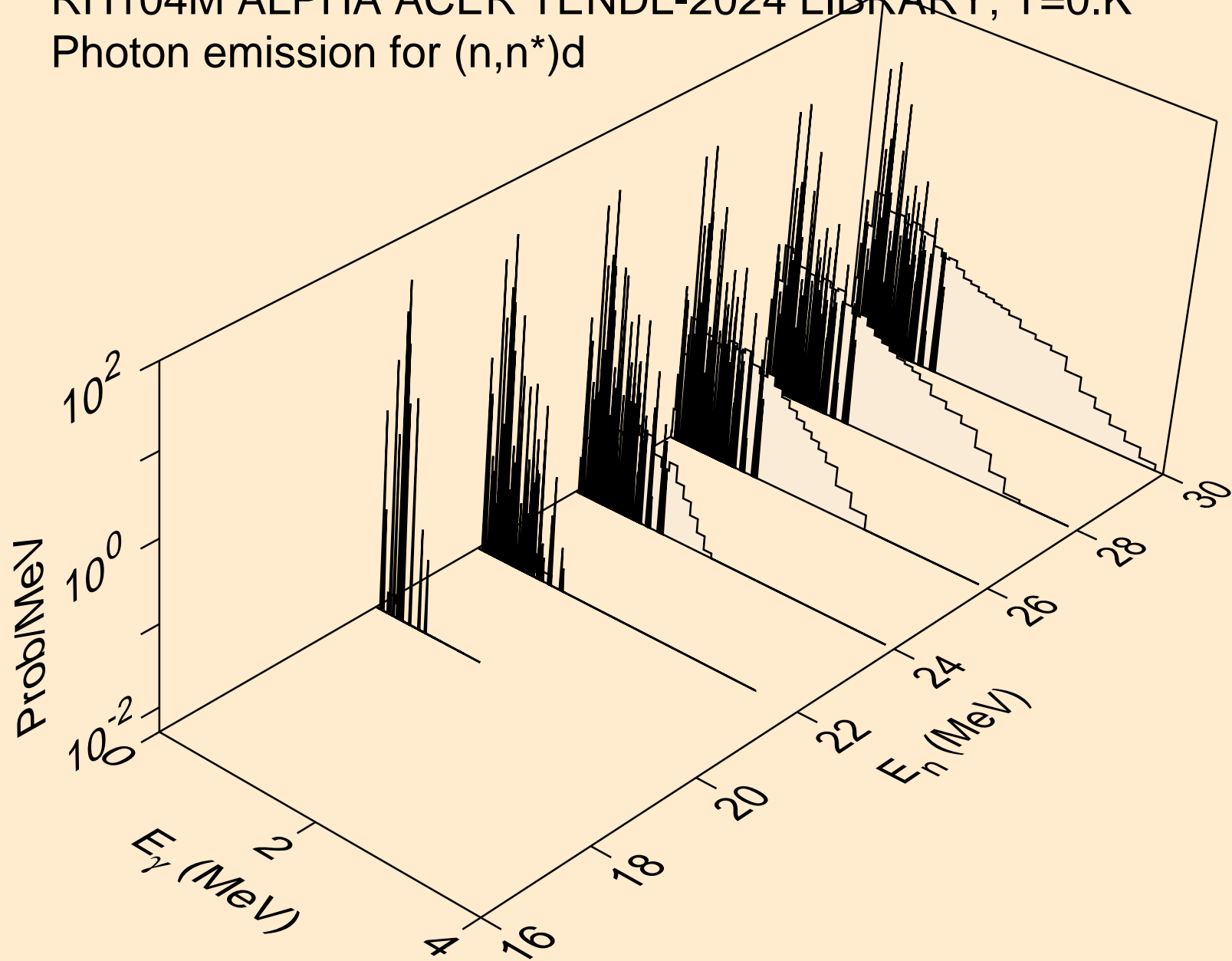

RH104M ALPHA ACER TENDL-2024 LIBRARY; T=0.K  
Photon emission for (n,n\*)t

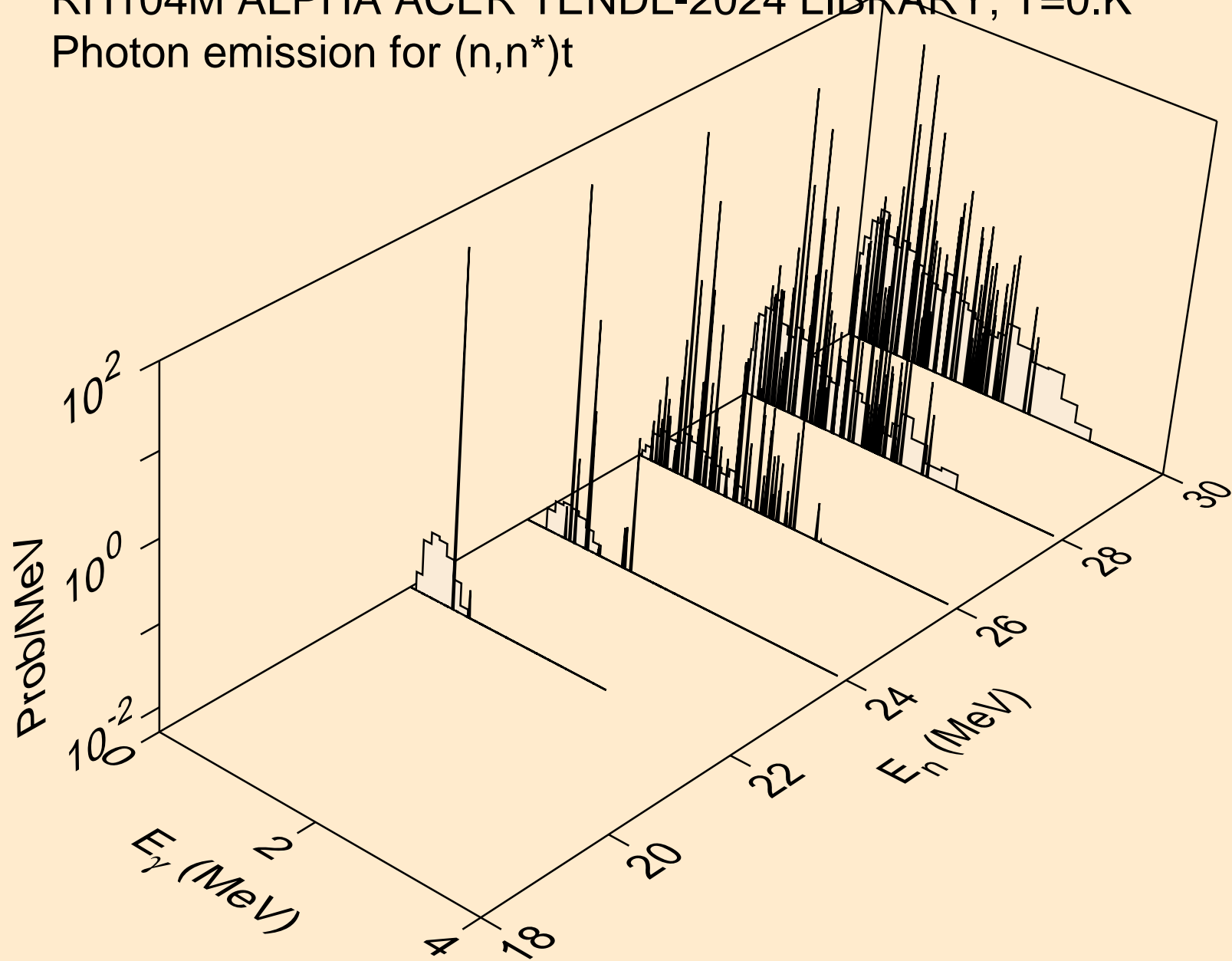

RH104M ALPHA ACER TENDL-2024 LIBRARY; T=0.K  
Photon emission for (n,n\*)he3

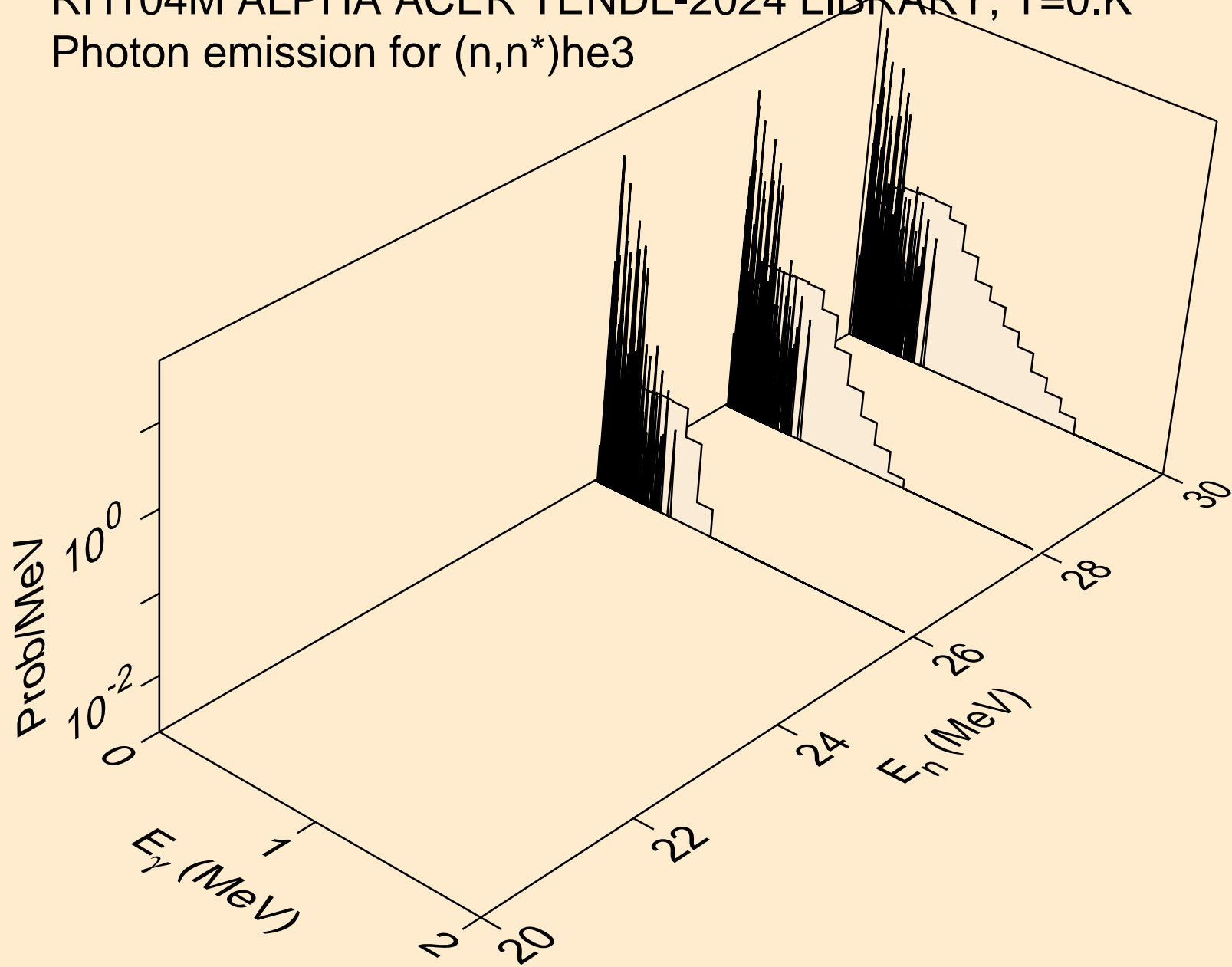

RH104M ALPHA ACER TENDL-2024 LIBRARY; T=0.K  
Photon emission for (n,2np)

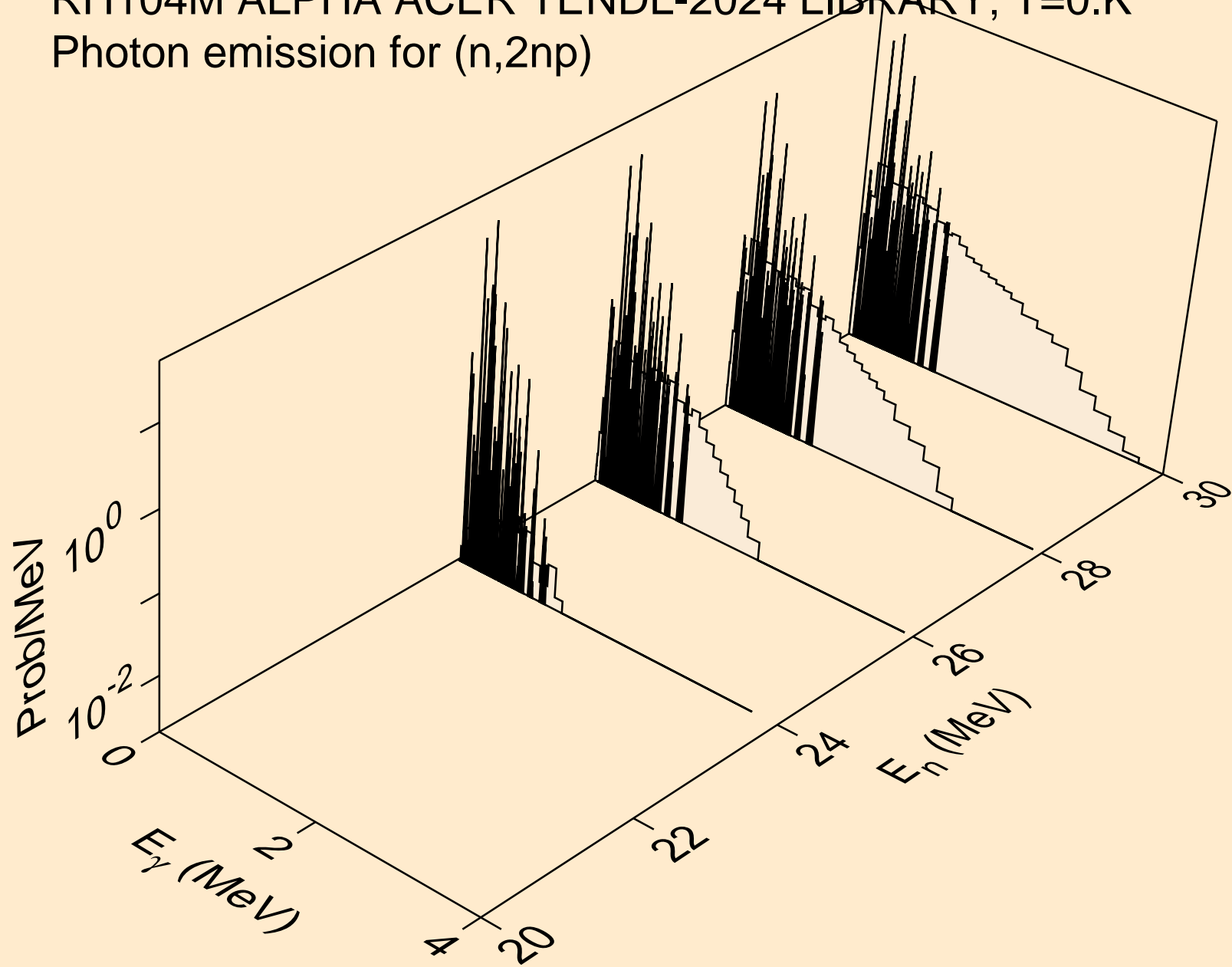

RH104M ALPHA ACER TENDL-2024 LIBRARY; T=0.K  
Photon emission for (n,n2p)

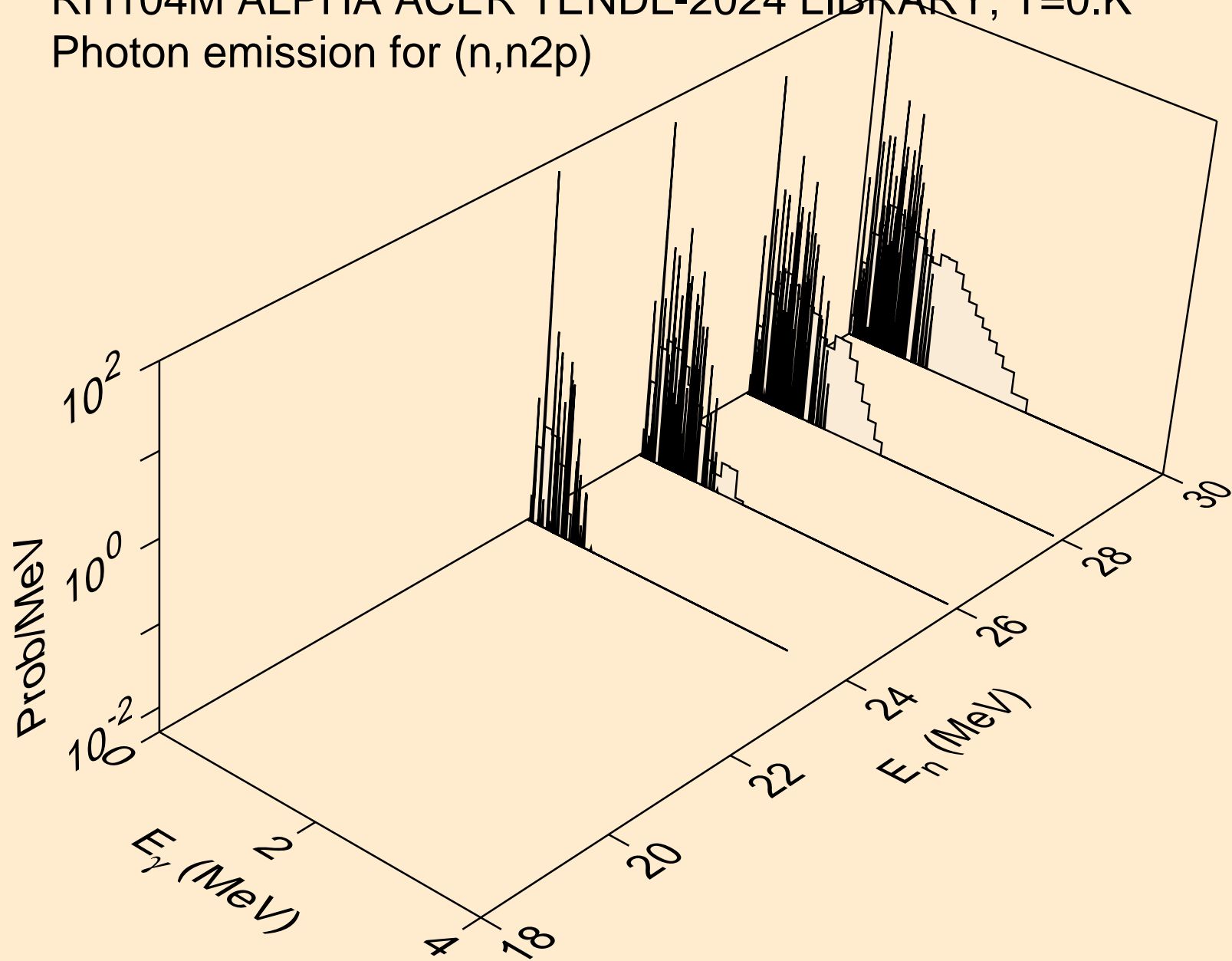

RH104M ALPHA ACER TENDL-2024 LIBRARY; T=0.K  
Photon emission for (n,npa)

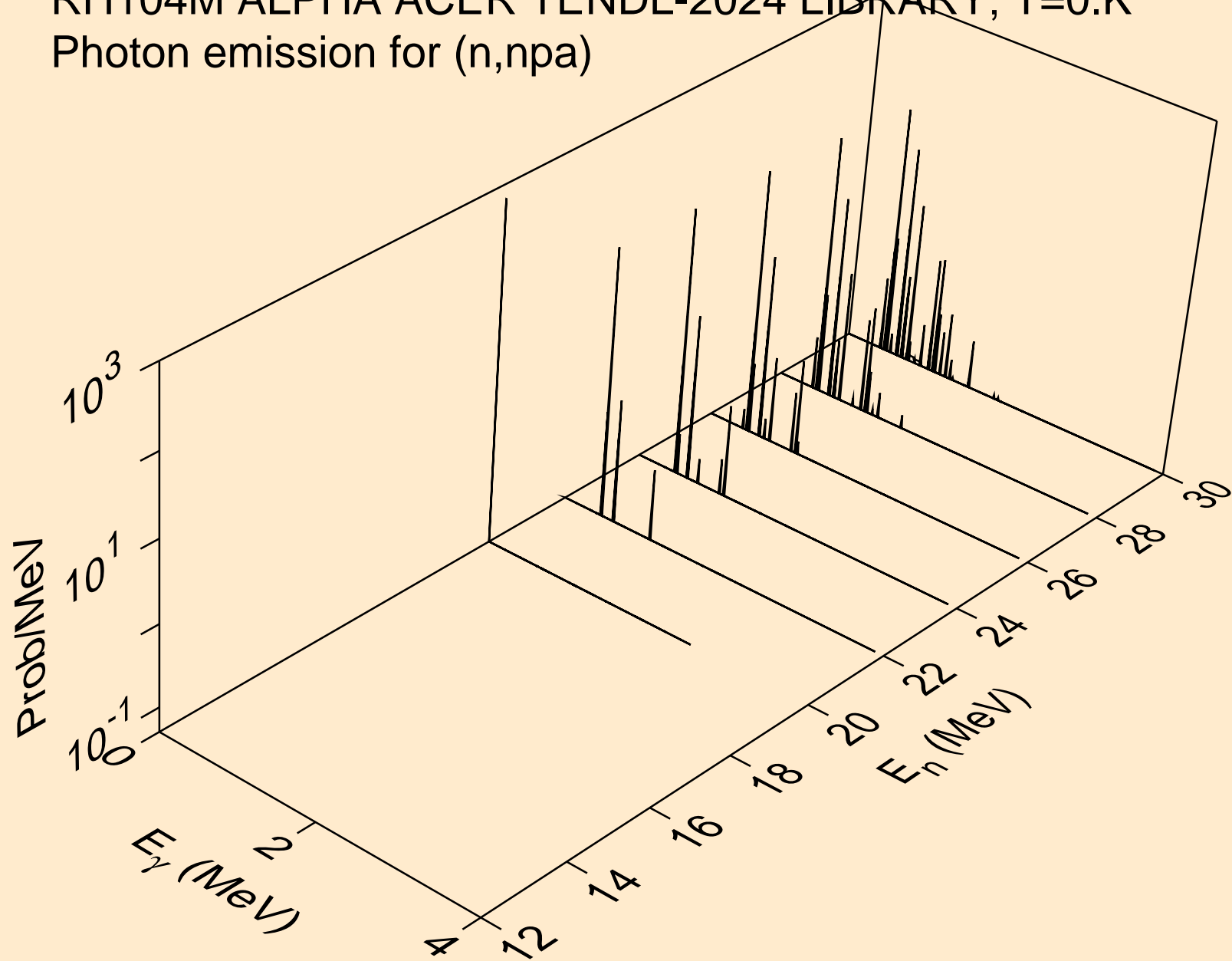

RH104M ALPHA ACER TENDL-2024 LIBRARY; T=0.K  
Photon emission for (n,gma)

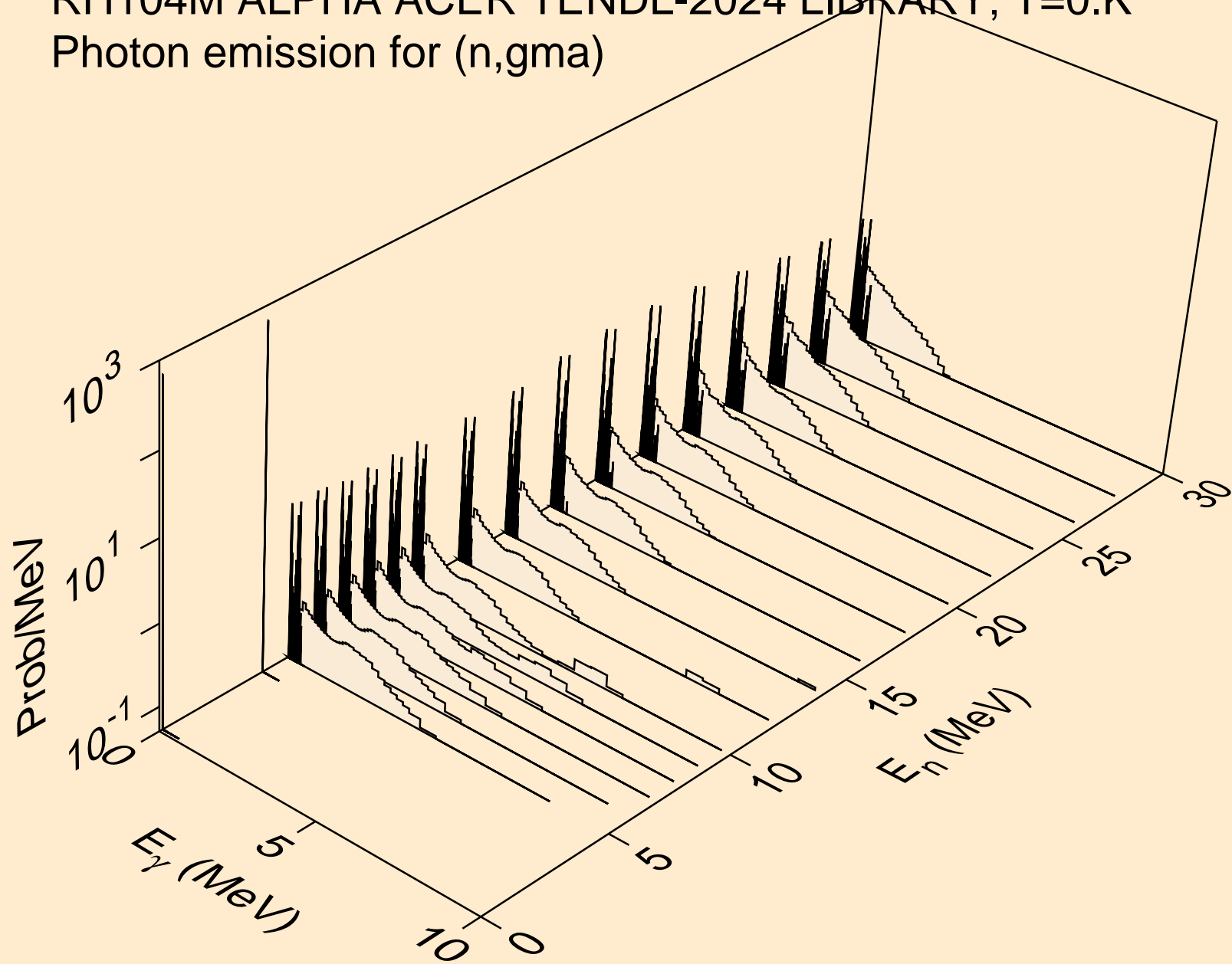

RH104M ALPHA ACER TENDL-2024 LIBRARY; T=0.K  
Photon emission for (n,p)

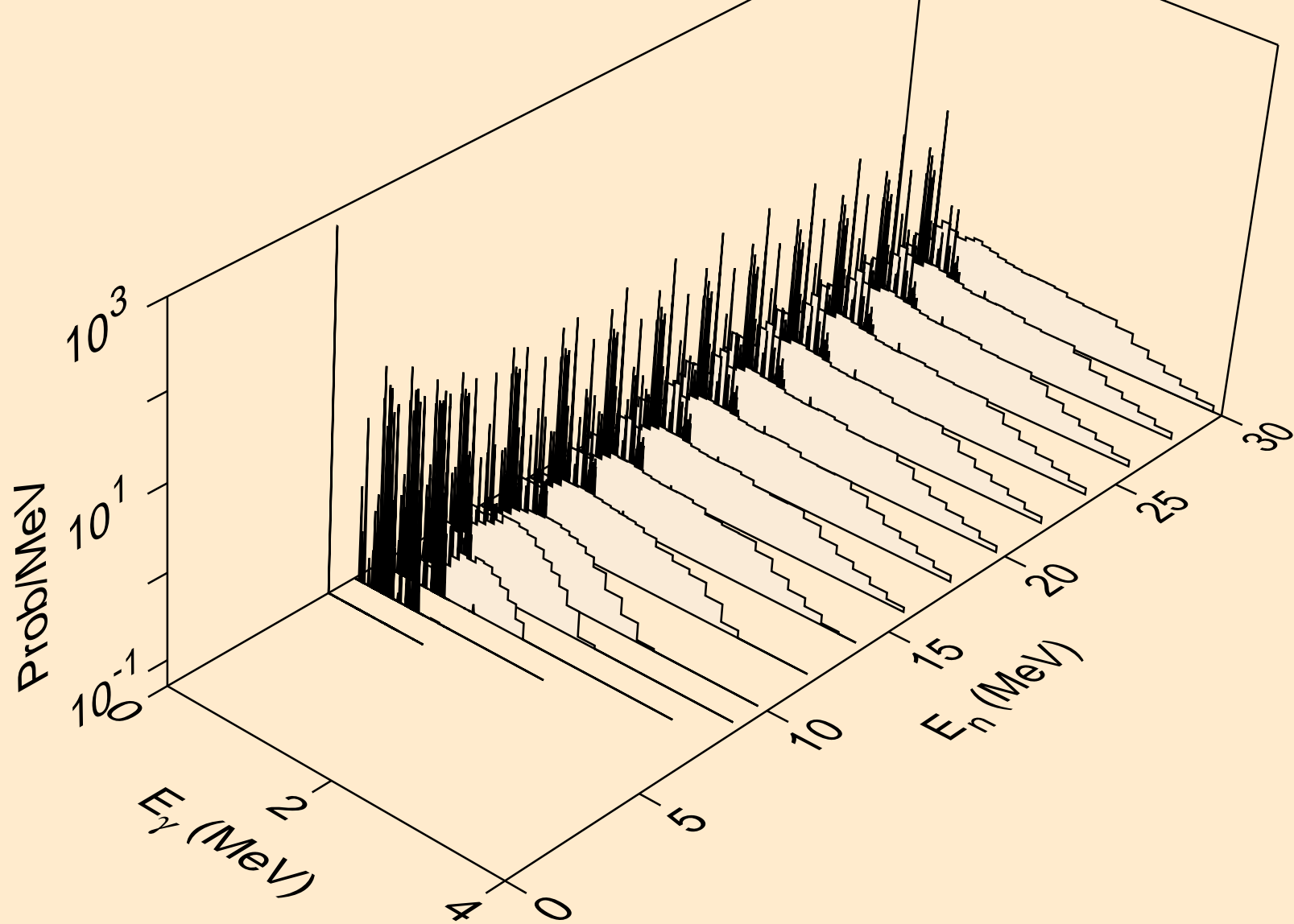

RH104M ALPHA ACER TENDL-2024 LIBRARY; T=0.K  
Photon emission for (n,d)

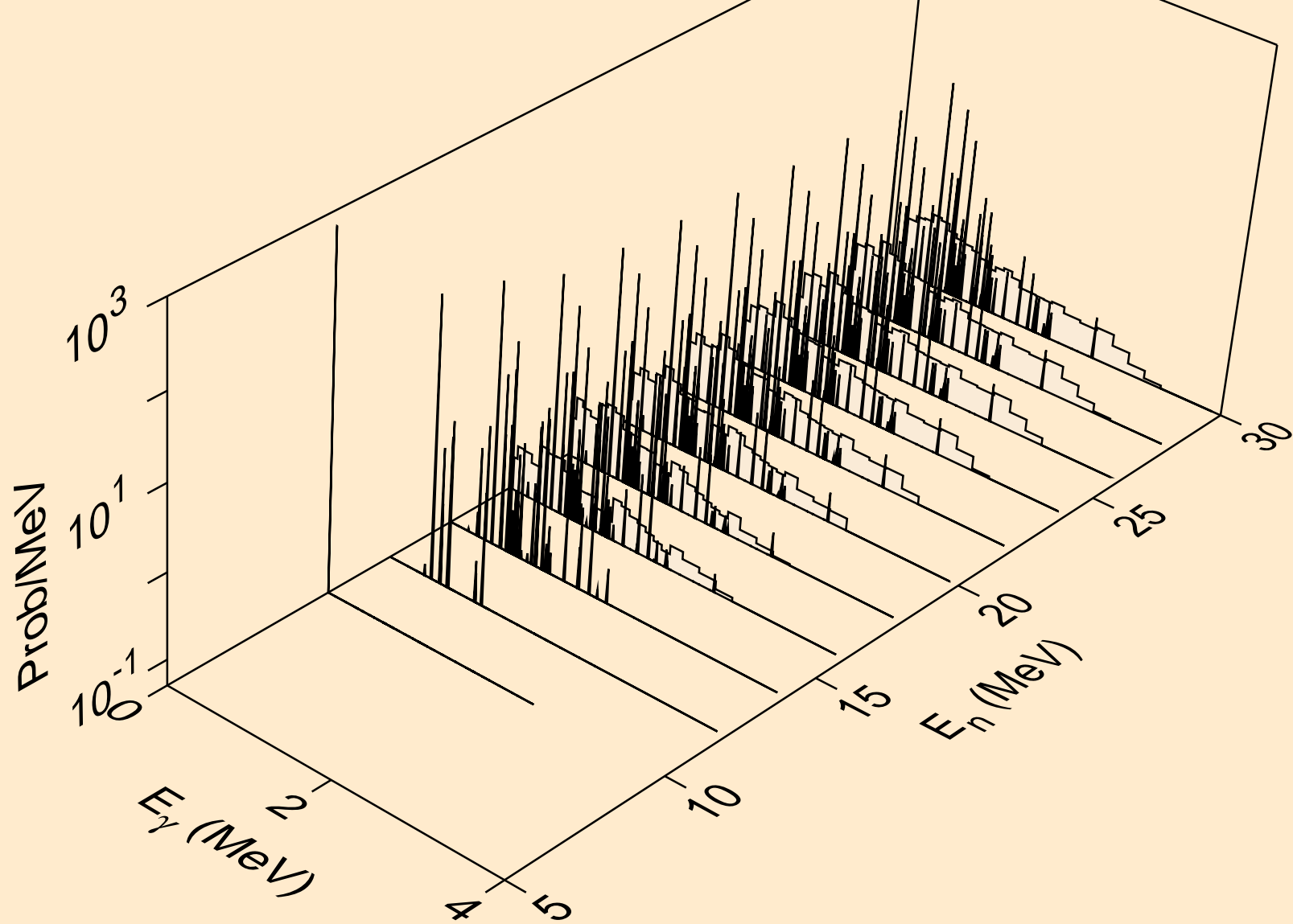

RH104M ALPHA ACER TENDL-2024 LIBRARY; T=0.K  
Photon emission for (n,t)

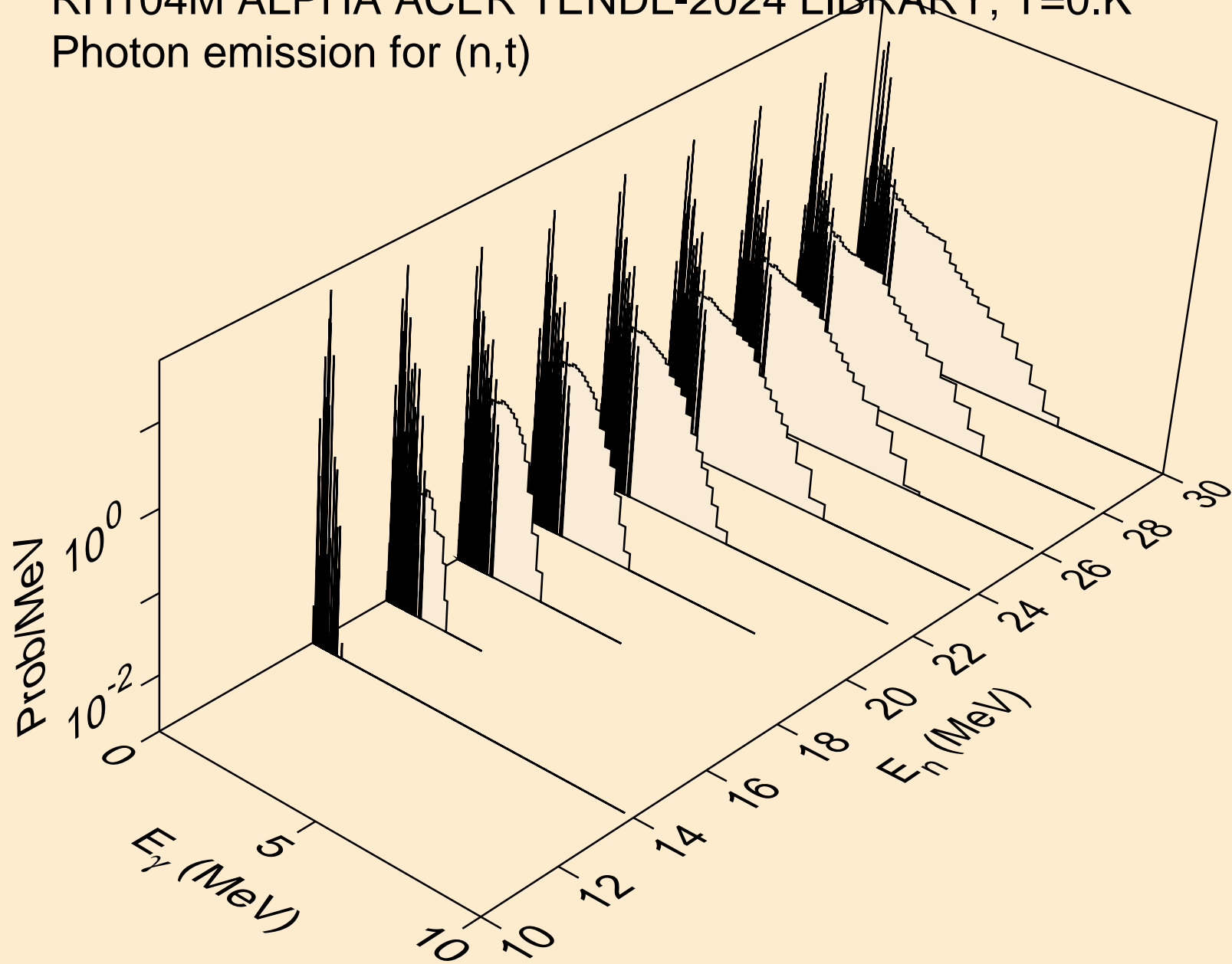

RH104M ALPHA ACER TENDL-2024 LIBRARY; T=0.K  
Photon emission for (n,he3)

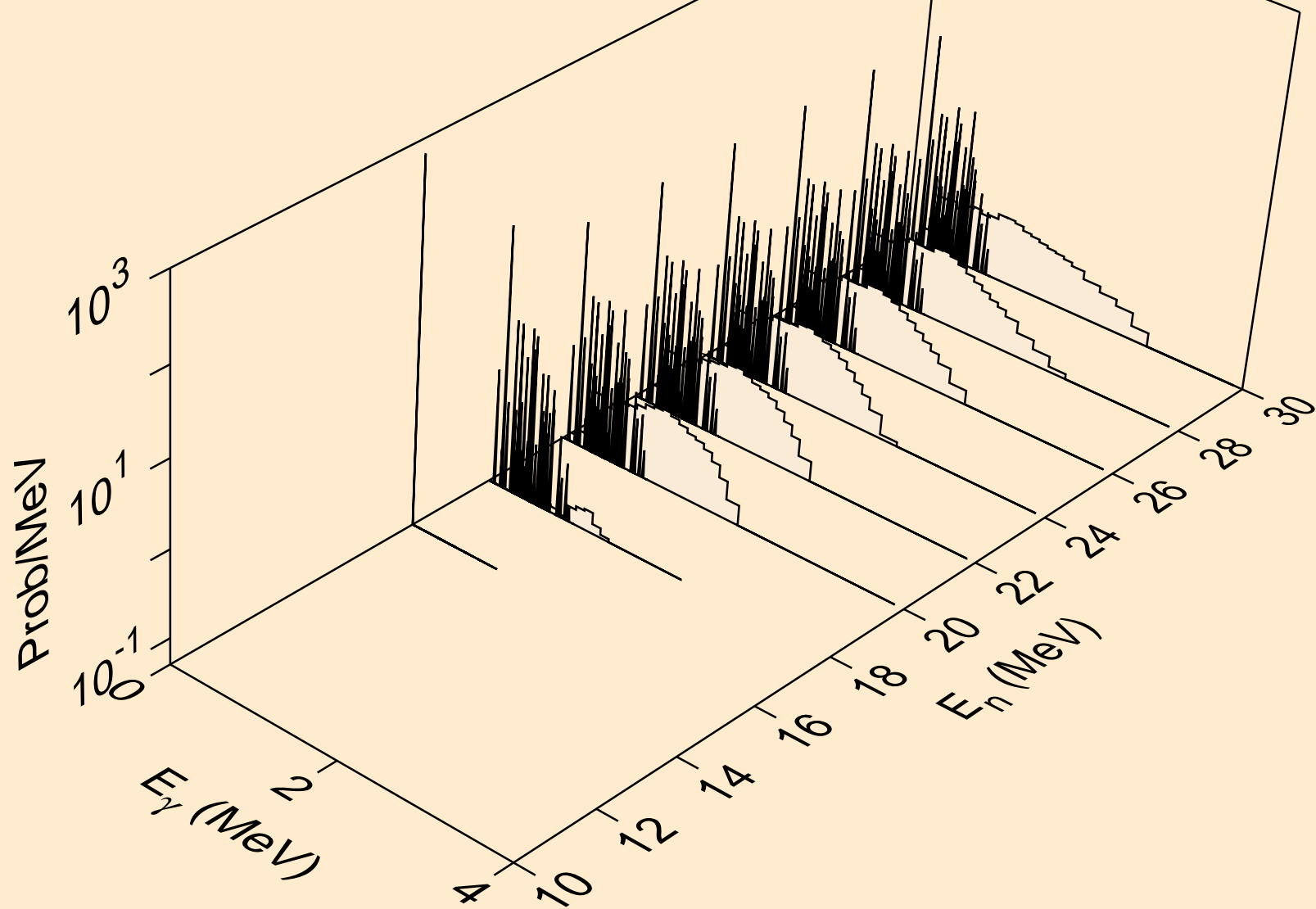

RH104M ALPHA ACER TENDL-2024 LIBRARY; T=0.K  
Photon emission for inelastic

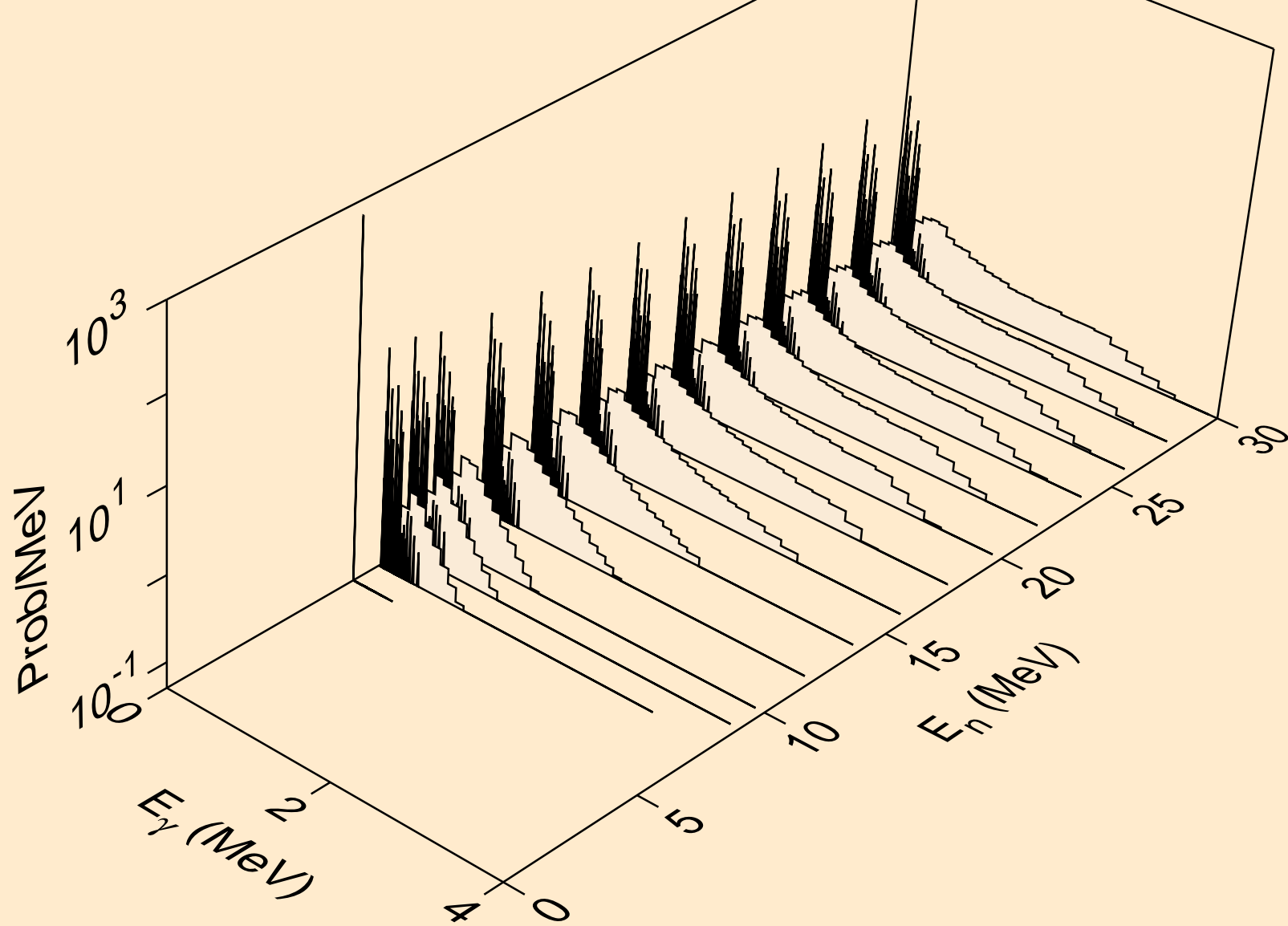

RH104M ALPHA ACER TENDL-2024 LIBRARY; T=0.K  
Photon emission for (n,2a)

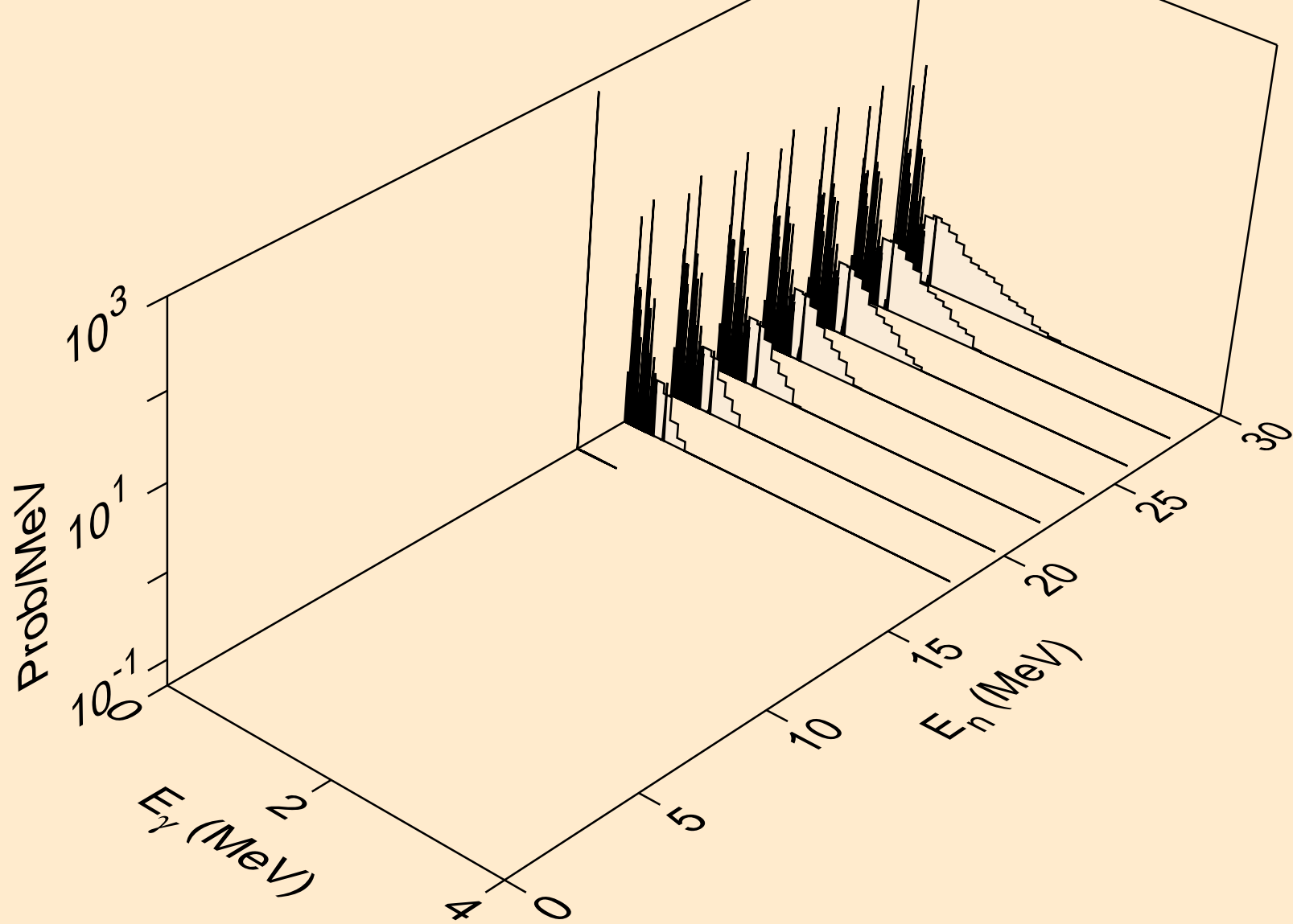

RH104M ALPHA ACER TENDL-2024 LIBRARY; T=0.K  
Photon emission for (n,2p)

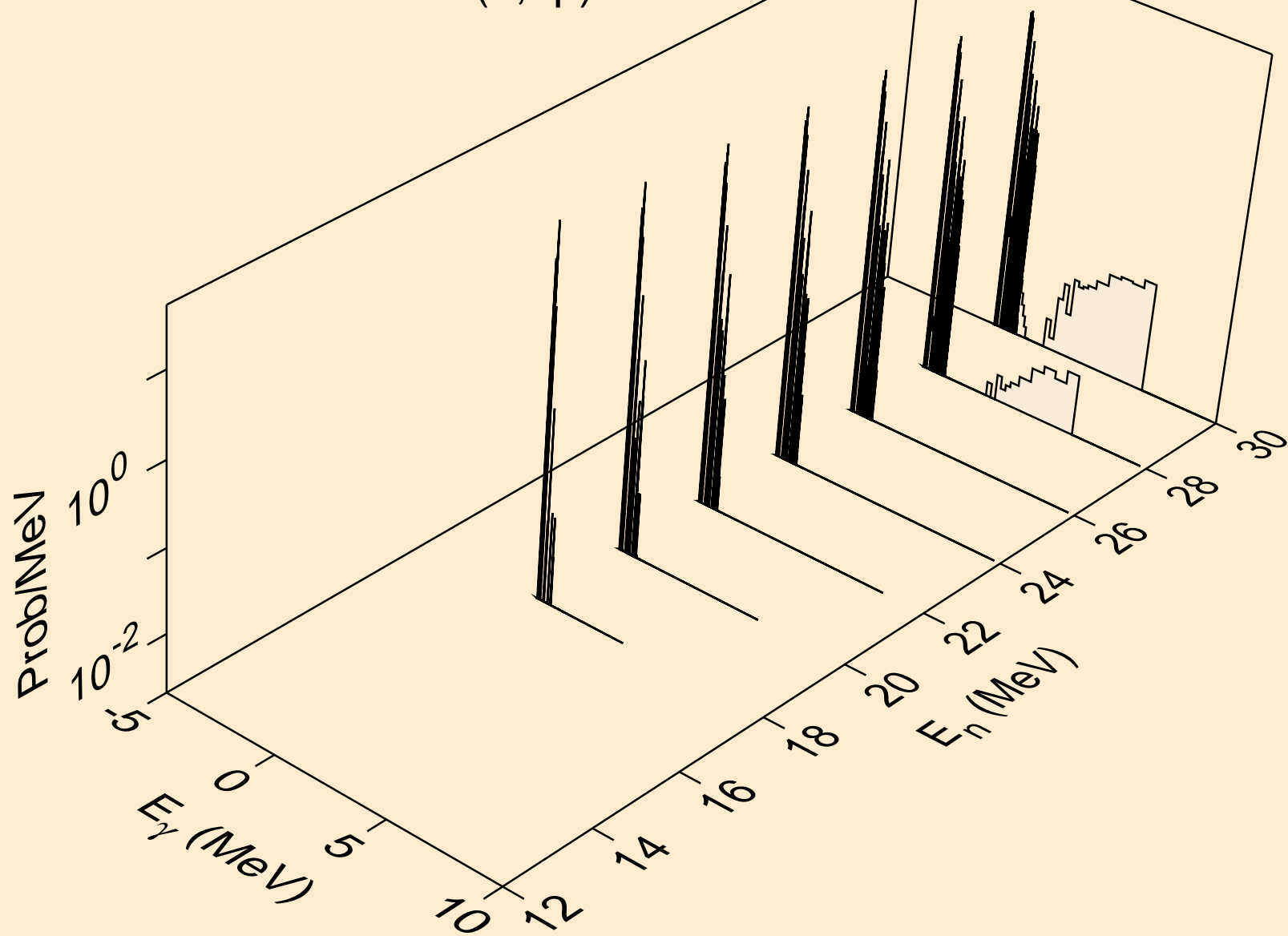

RH104M ALPHA ACER TENDL-2024 LIBRARY; T=0.K  
Photon emission for (n,pa)

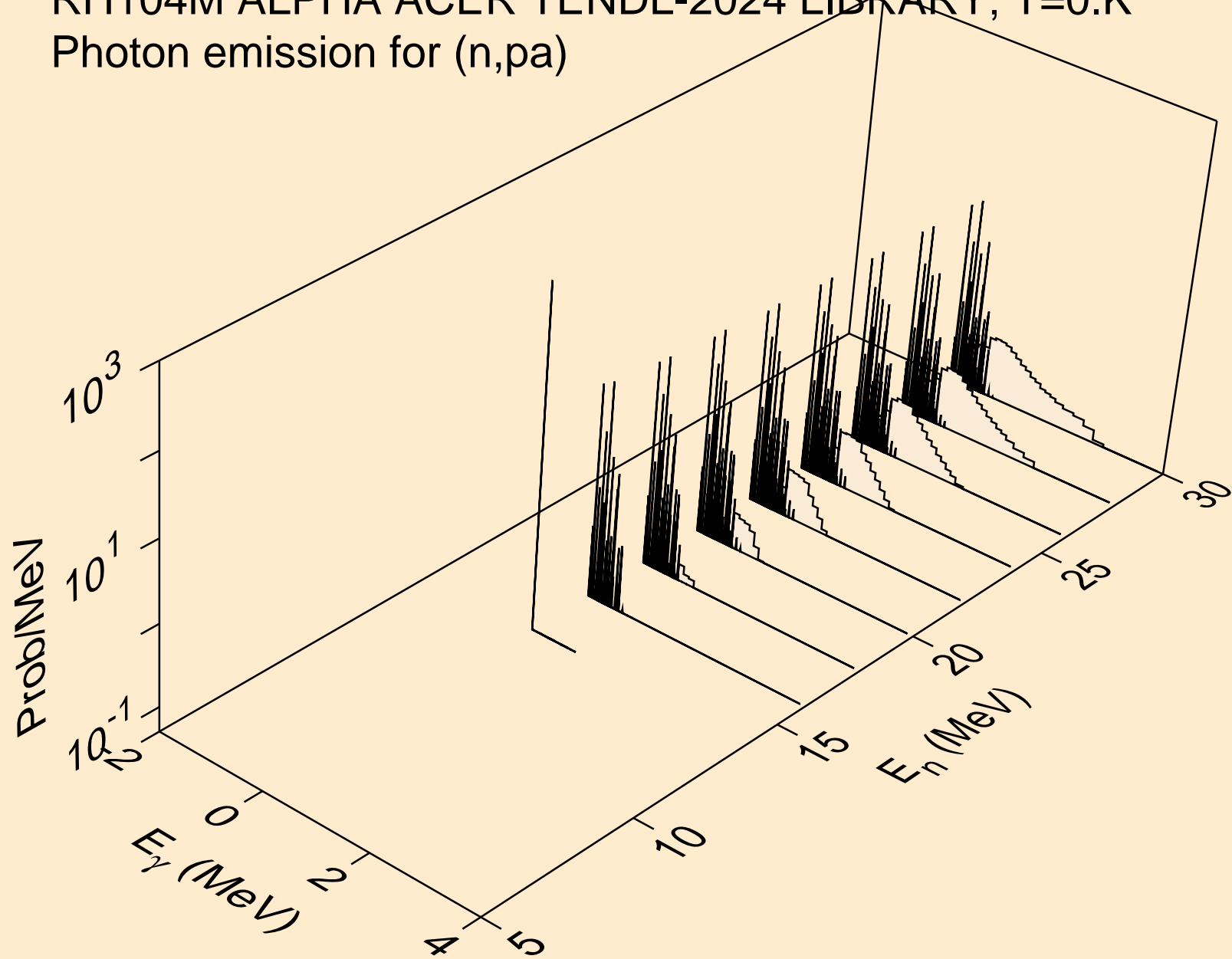

RH104M ALPHA ACER TENDL-2024 LIBRARY; T=0.K  
Photon emission for (n,pd)

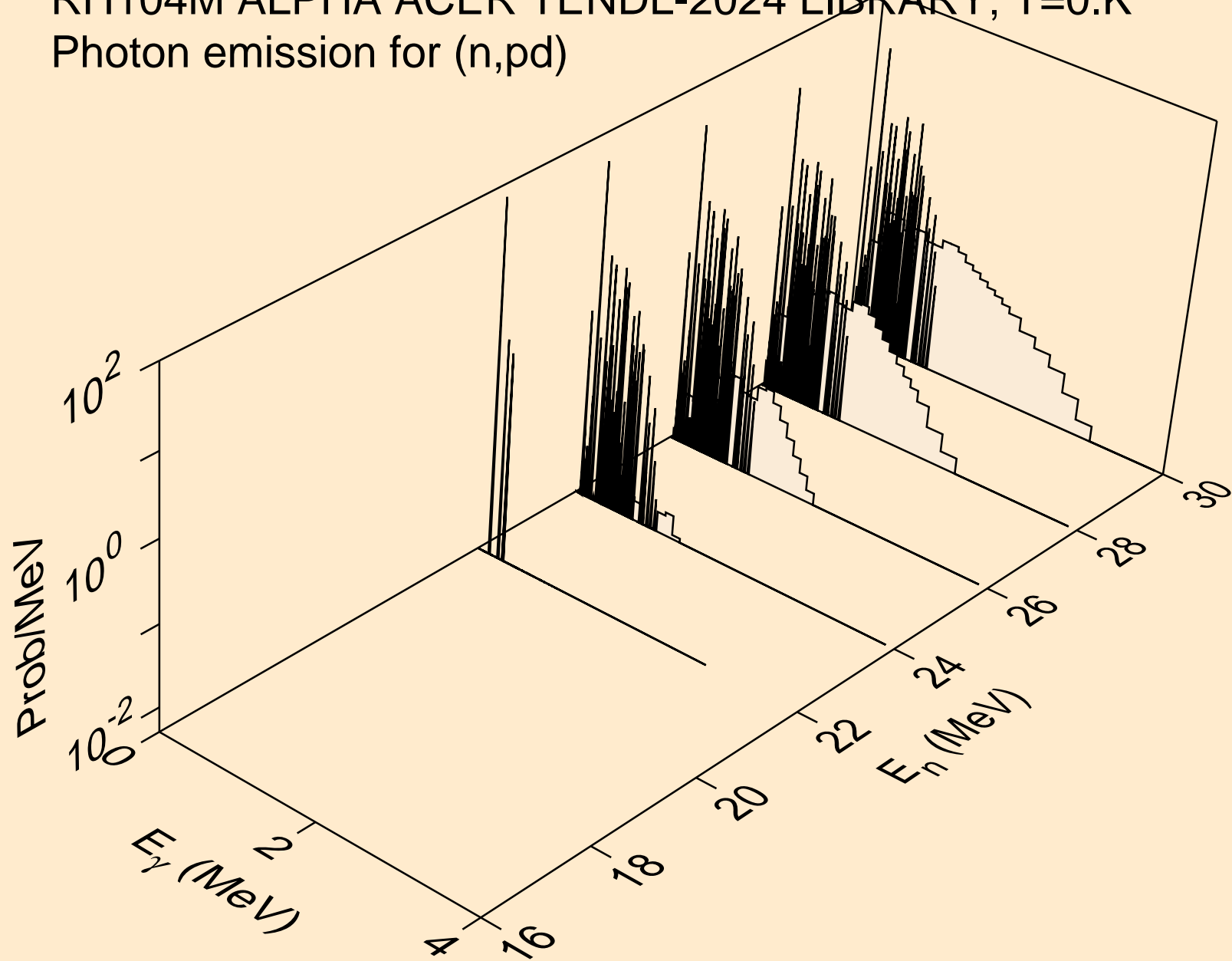

RH104M ALPHA ACER TENDL-2024 LIBRARY; T=0.K  
Photon emission for (n,da)

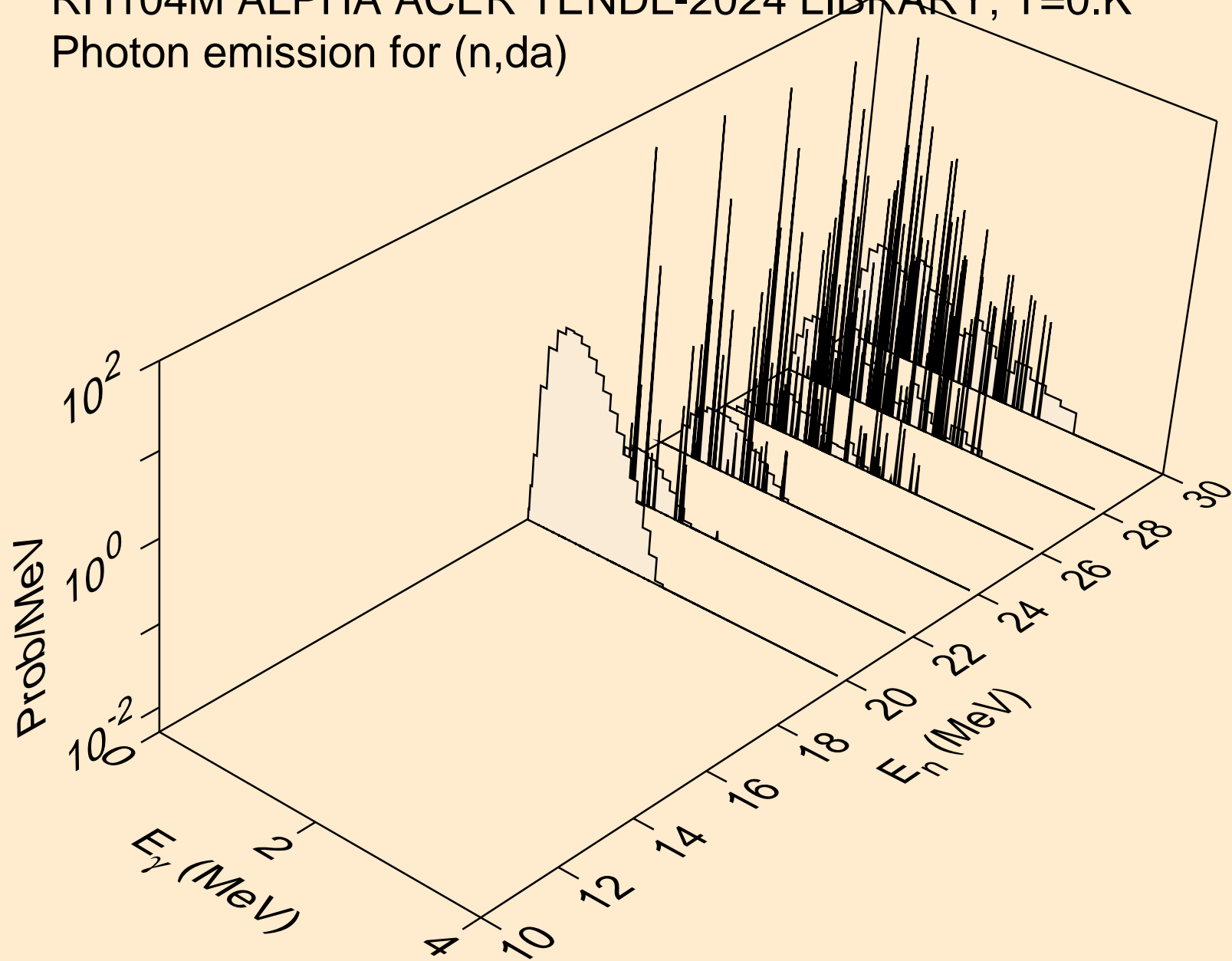

RH104M ALPHA ACER TENDL-2024 LIBRARY; T=0.K  
Particle heating contributions

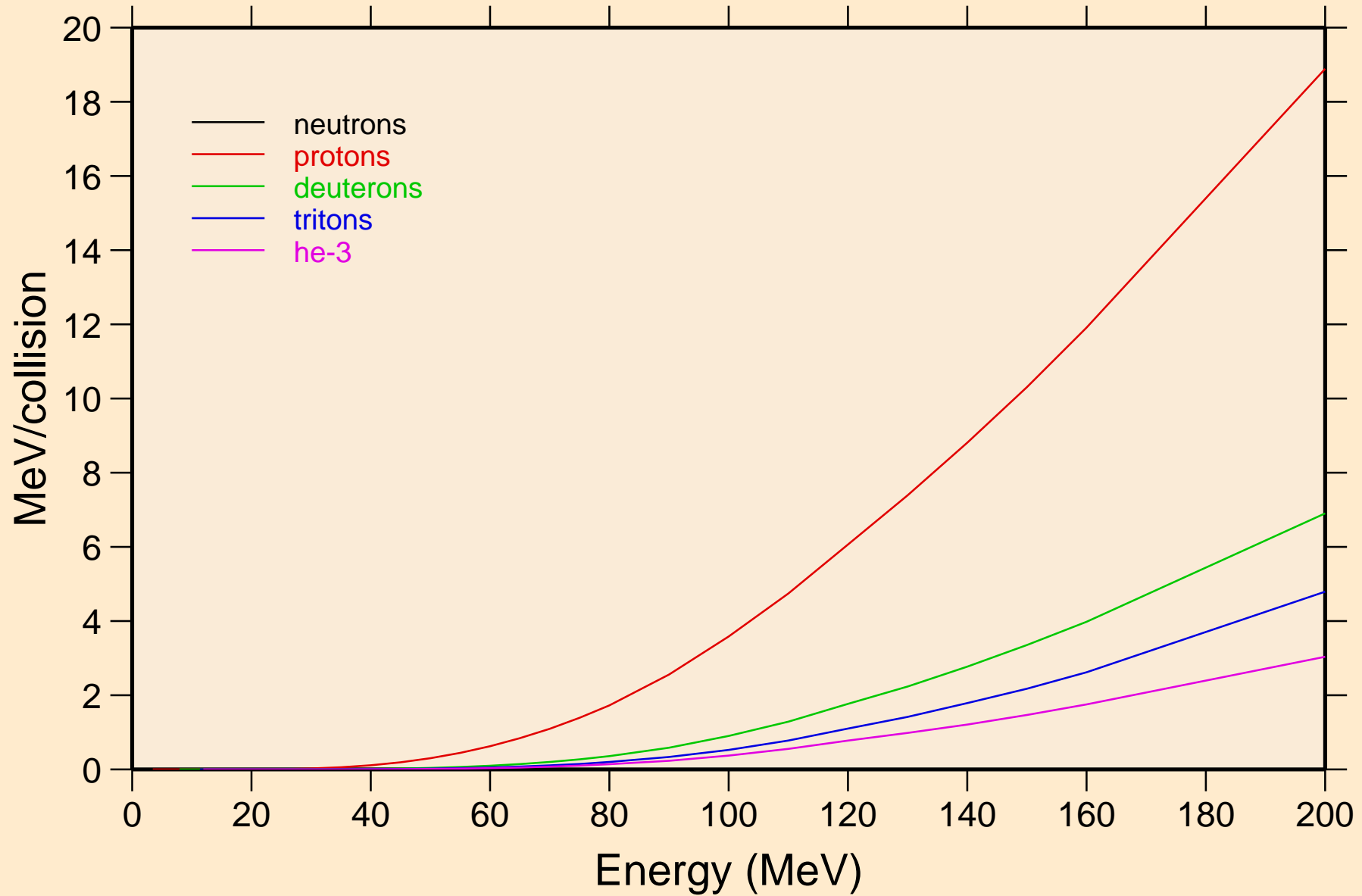

RH104M ALPHA ACER TENDL-2024 LIBRARY; T=0.K  
Recoil Heating

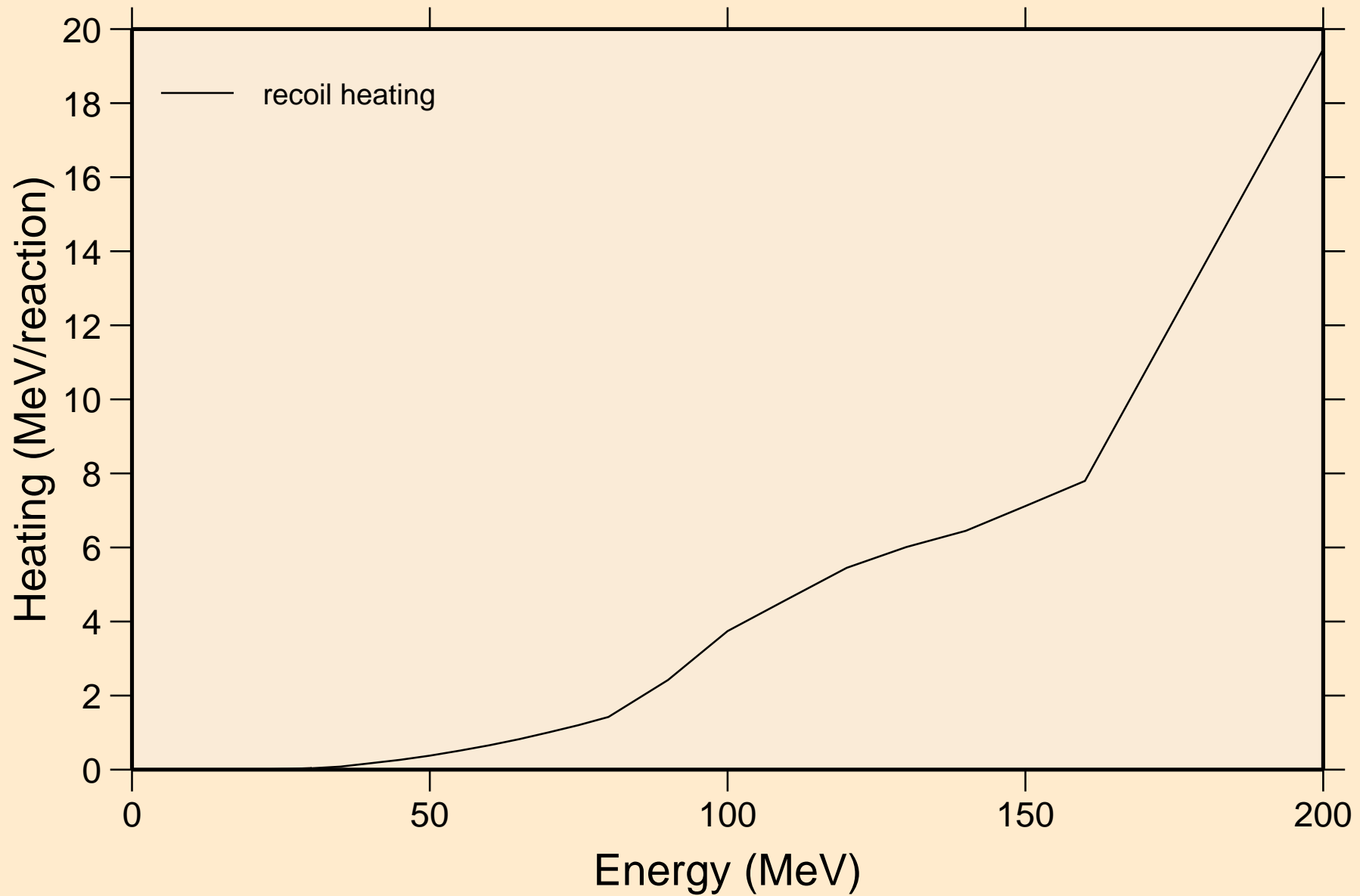

RH104M ALPHA ACER TENDL-2024 LIBRARY; T=0.K  
Particle production cross sections

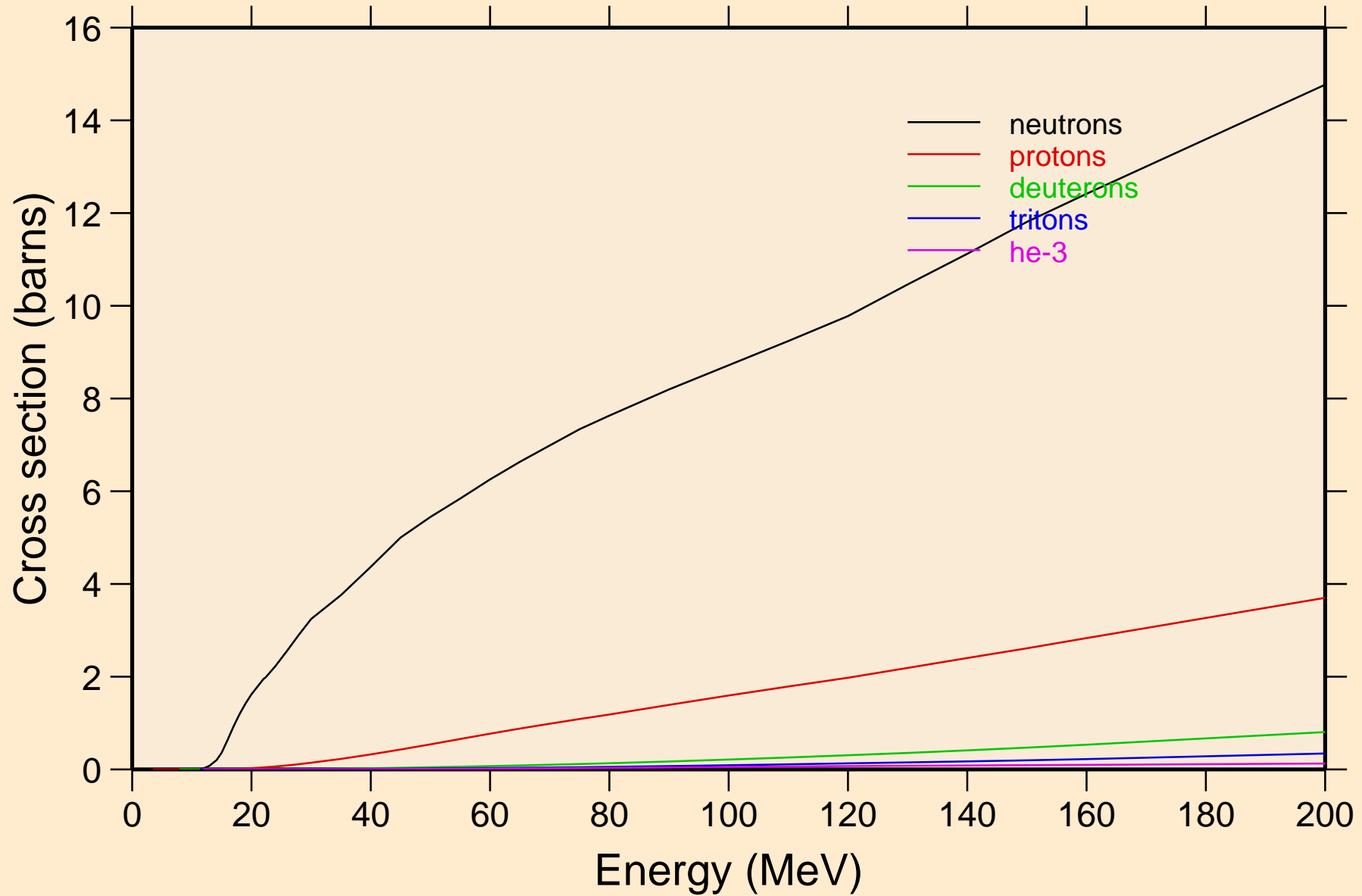

RH104M ALPHA ACER TENDL-2024 LIBRARY; T=0.K  
neutrons from (a,n)

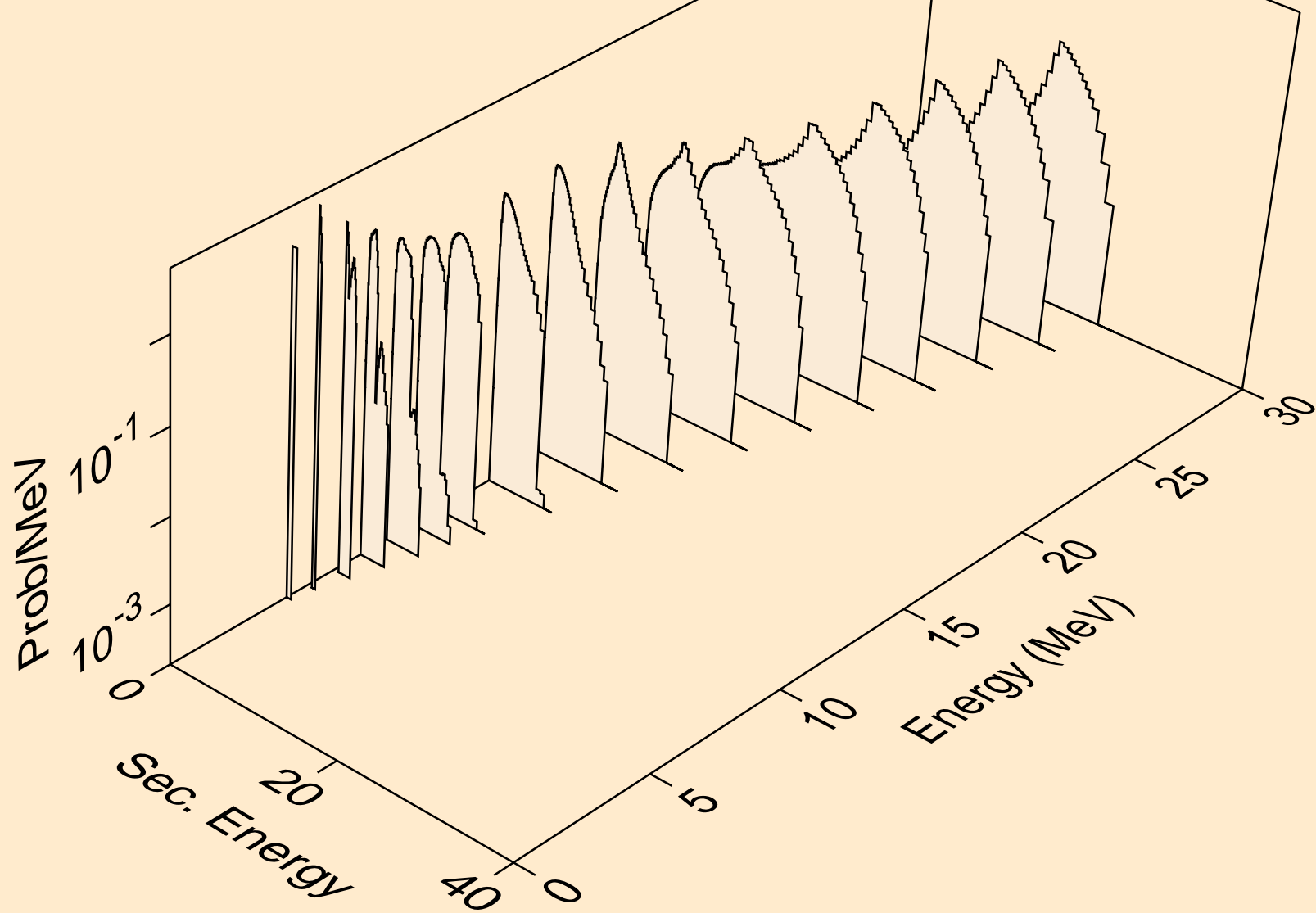

RH104M ALPHA ACER TENDL-2024 LIBRARY; T=0.K  
neutrons from (a,x)

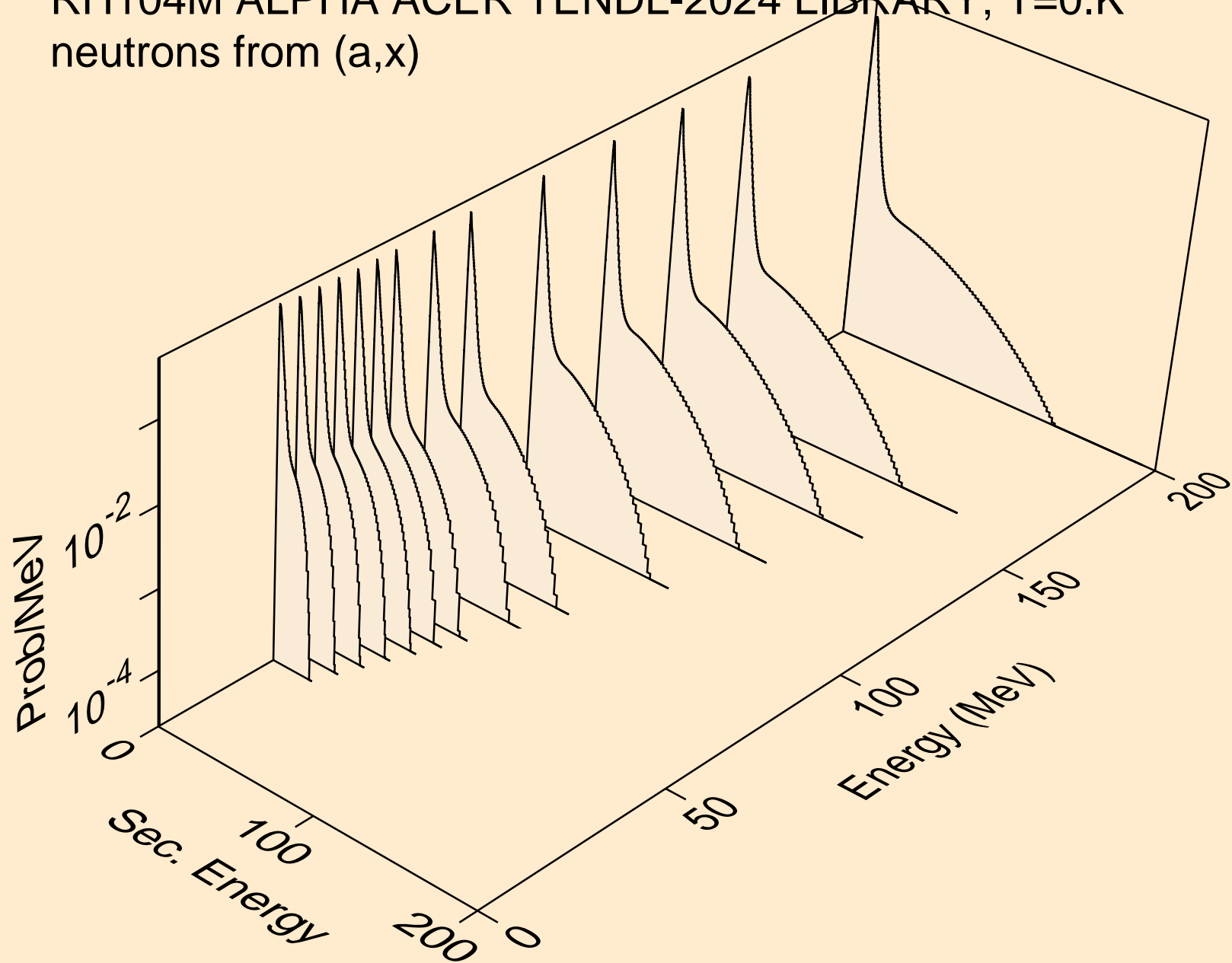

RH104M ALPHA ACER TENDL-2024 LIBRARY; T=0.K  
neutrons from (a,2nd)

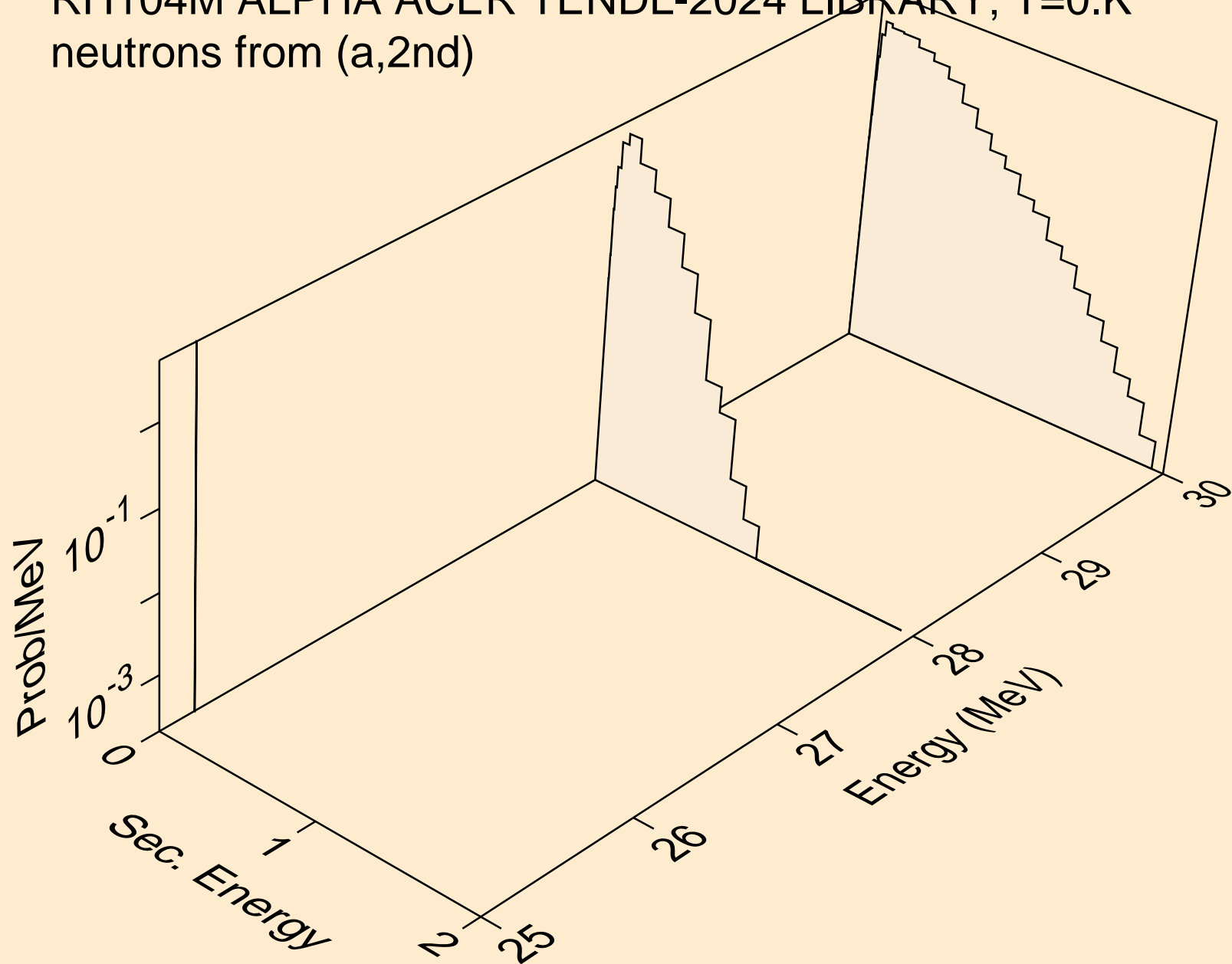

RH104M ALPHA ACER TENDL-2024 LIBRARY; T=0.K  
neutrons from (a,2n)

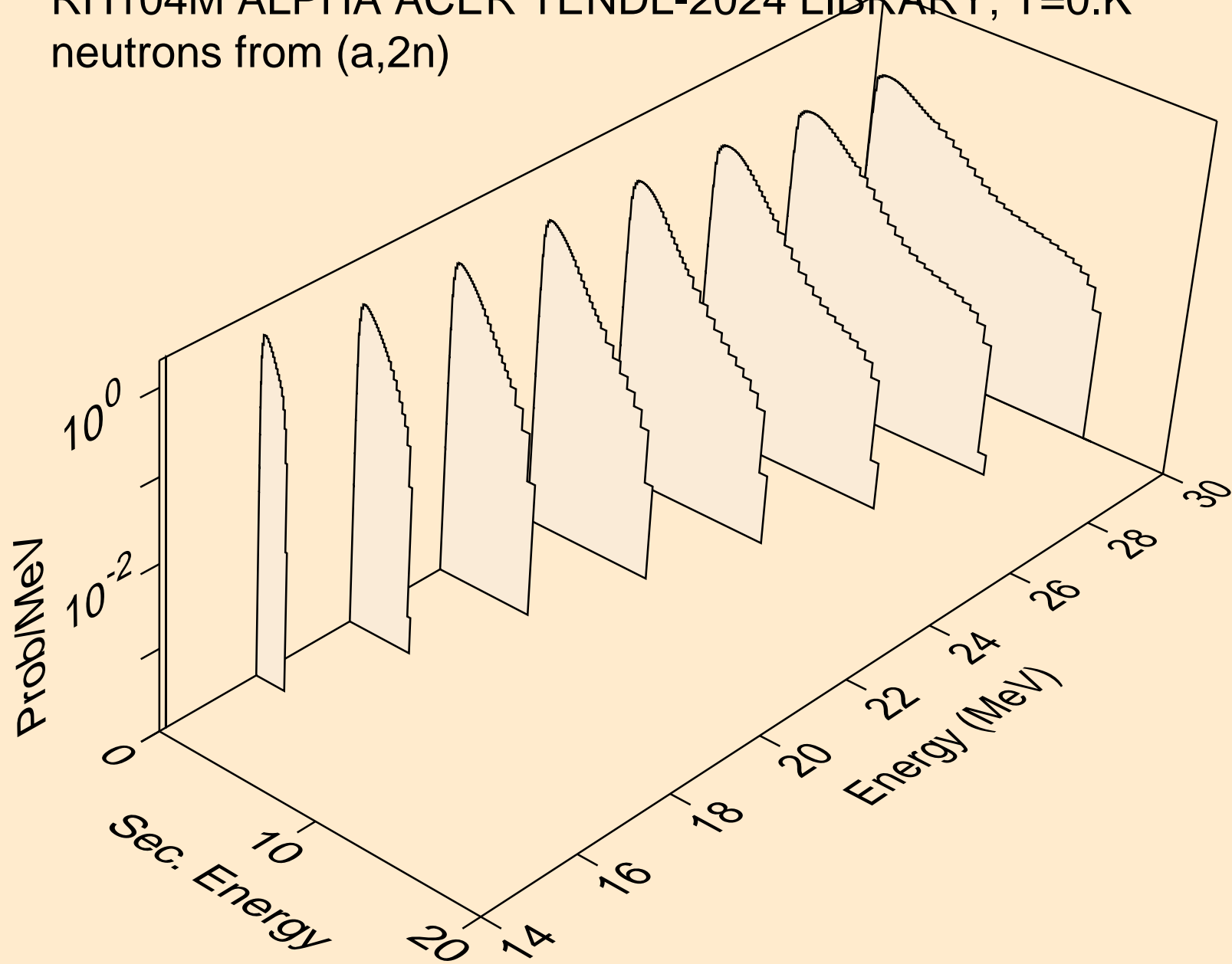

RH104M ALPHA ACER TENDL-2024 LIBRARY; T=0.K  
neutrons from (a,3n)

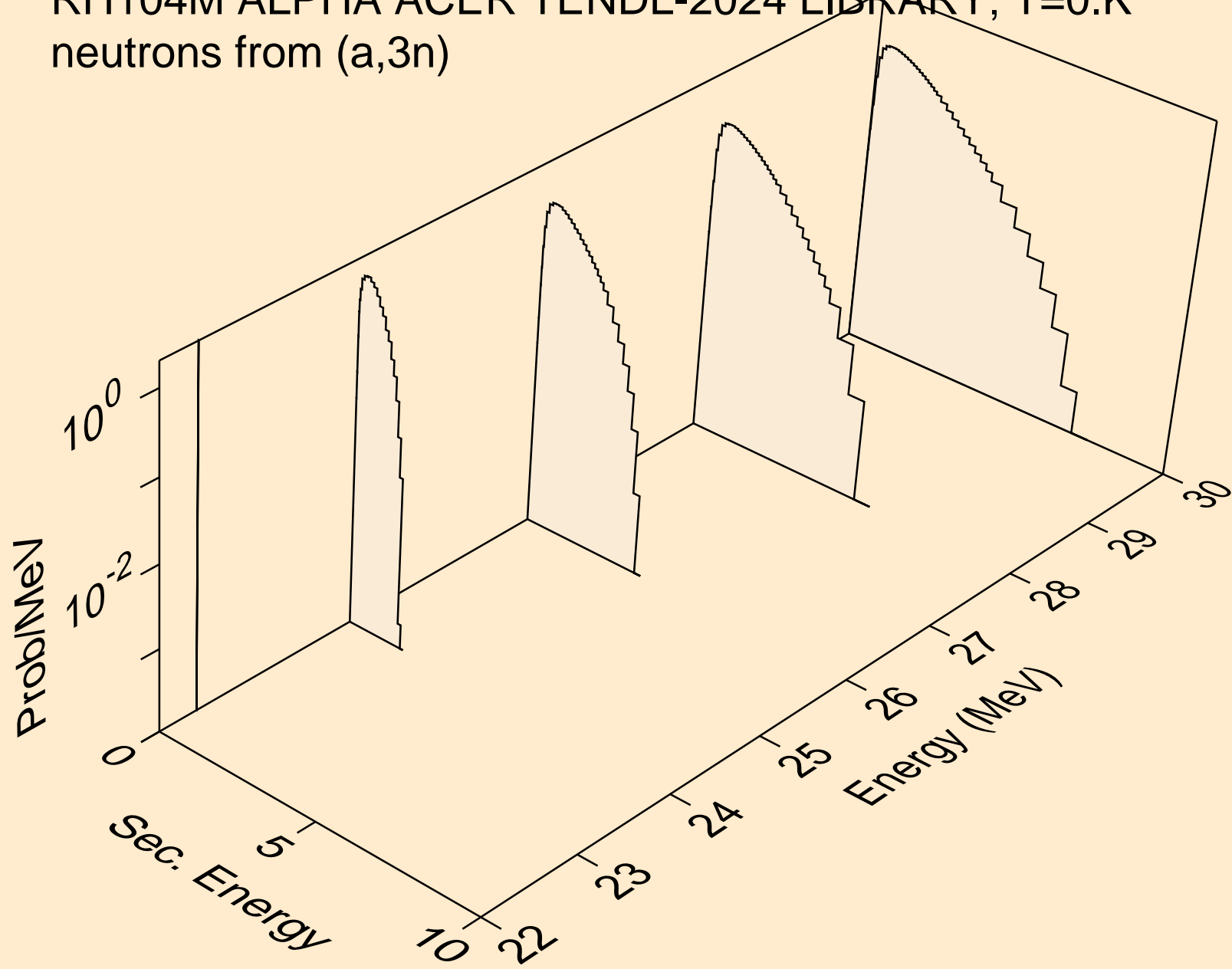

RH104M ALPHA ACER TENDL-2024 LIBRARY; T=0.K  
neutrons from (a,n\*)a

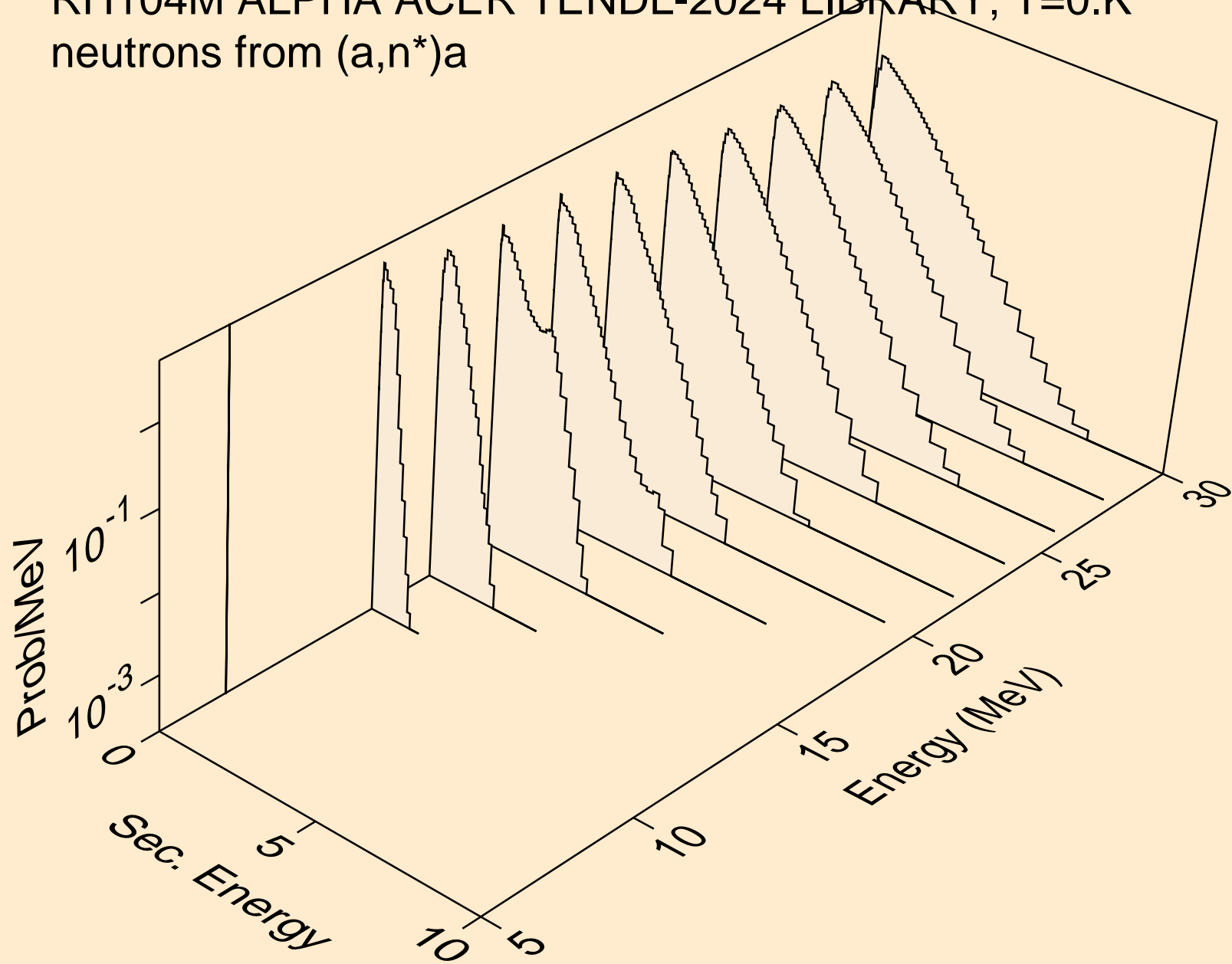

RH104M ALPHA ACER TENDL-2024 LIBRARY; T=0.K  
neutrons from (a,2n)a

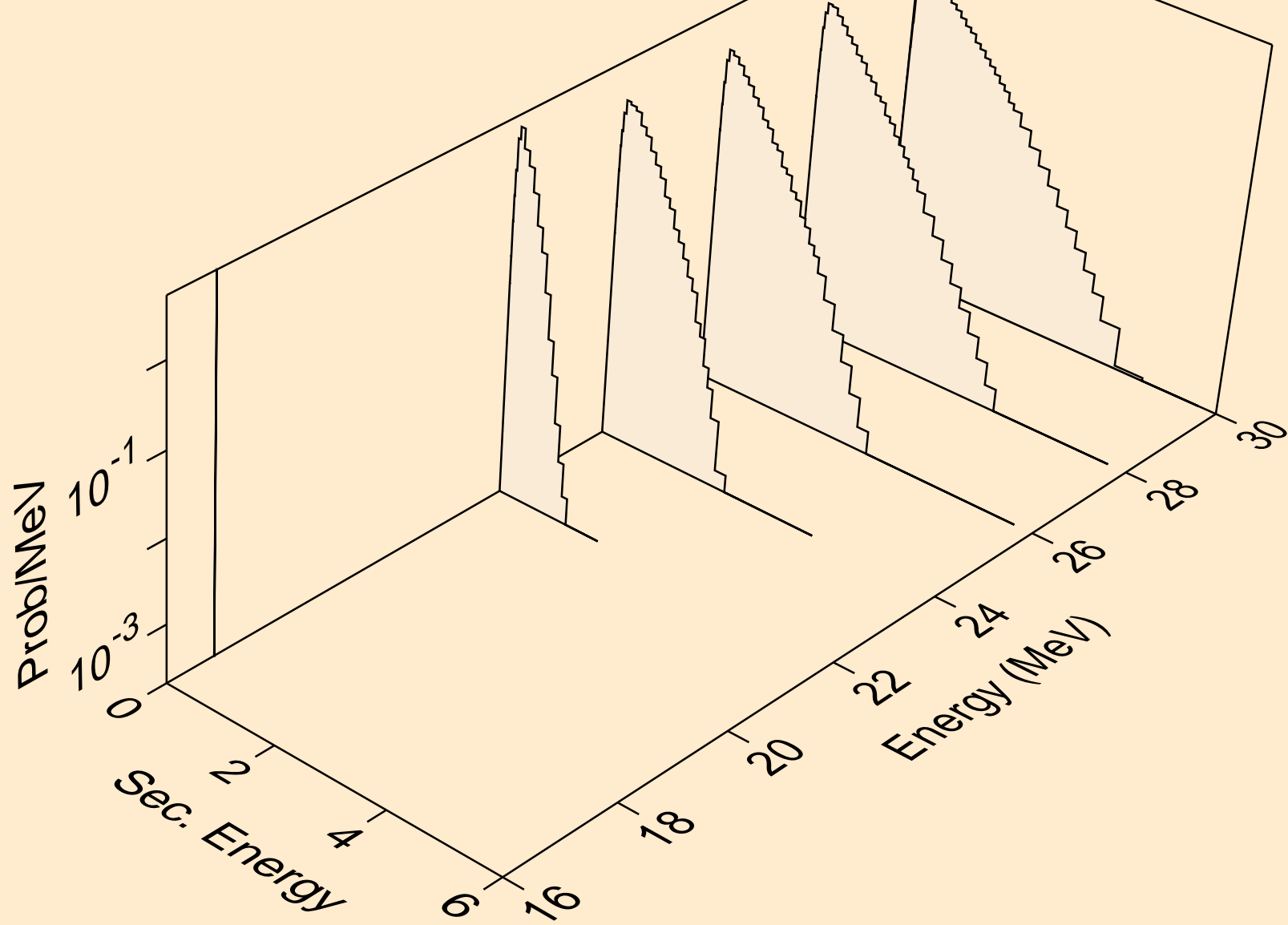

RH104M ALPHA ACER TENDL-2024 LIBRARY; T=0.K  
neutrons from (a,n\*)p

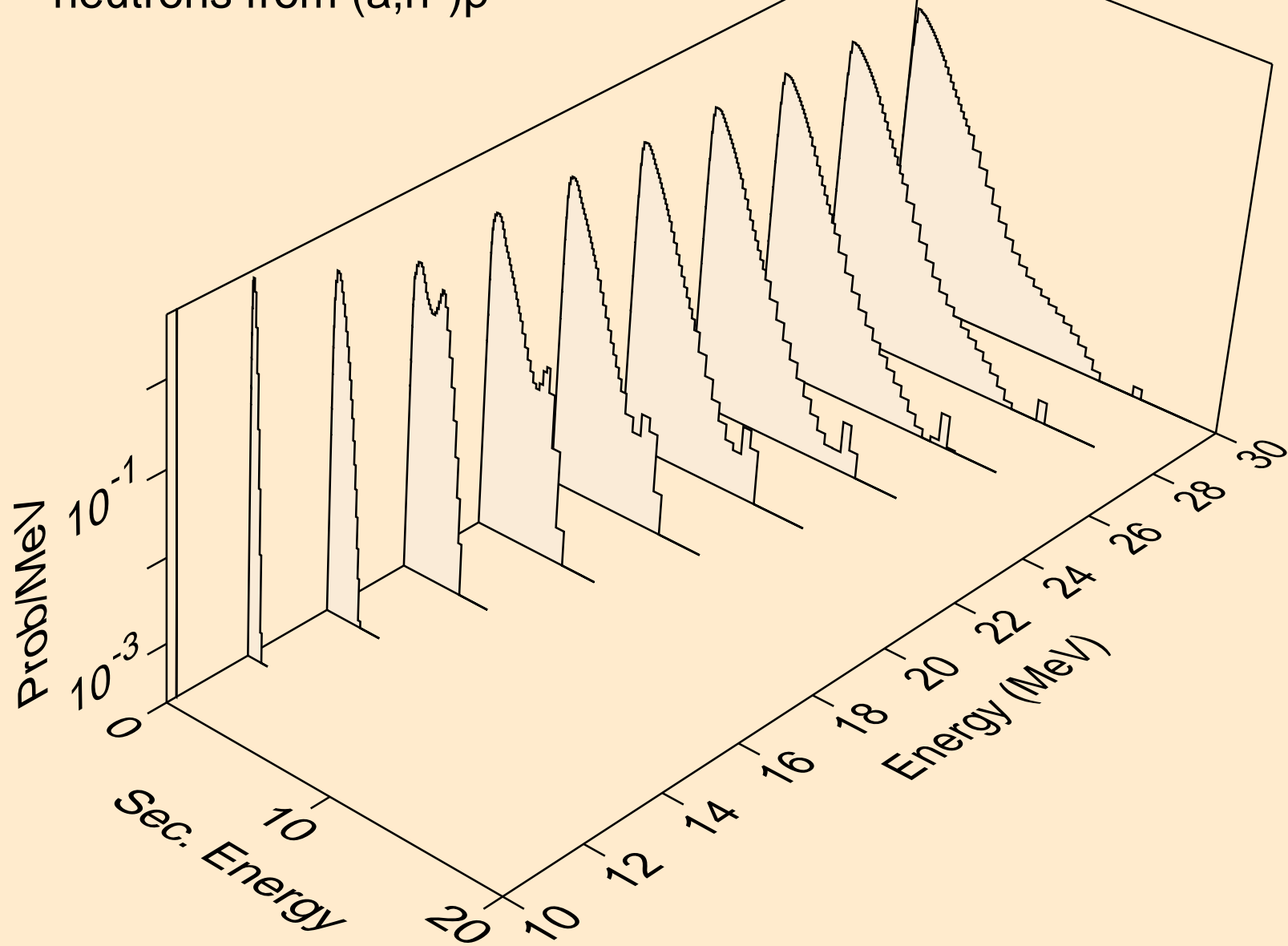

RH104M ALPHA ACER TENDL-2024 LIBRARY; T=0.K  
neutrons from (a,n\*)d

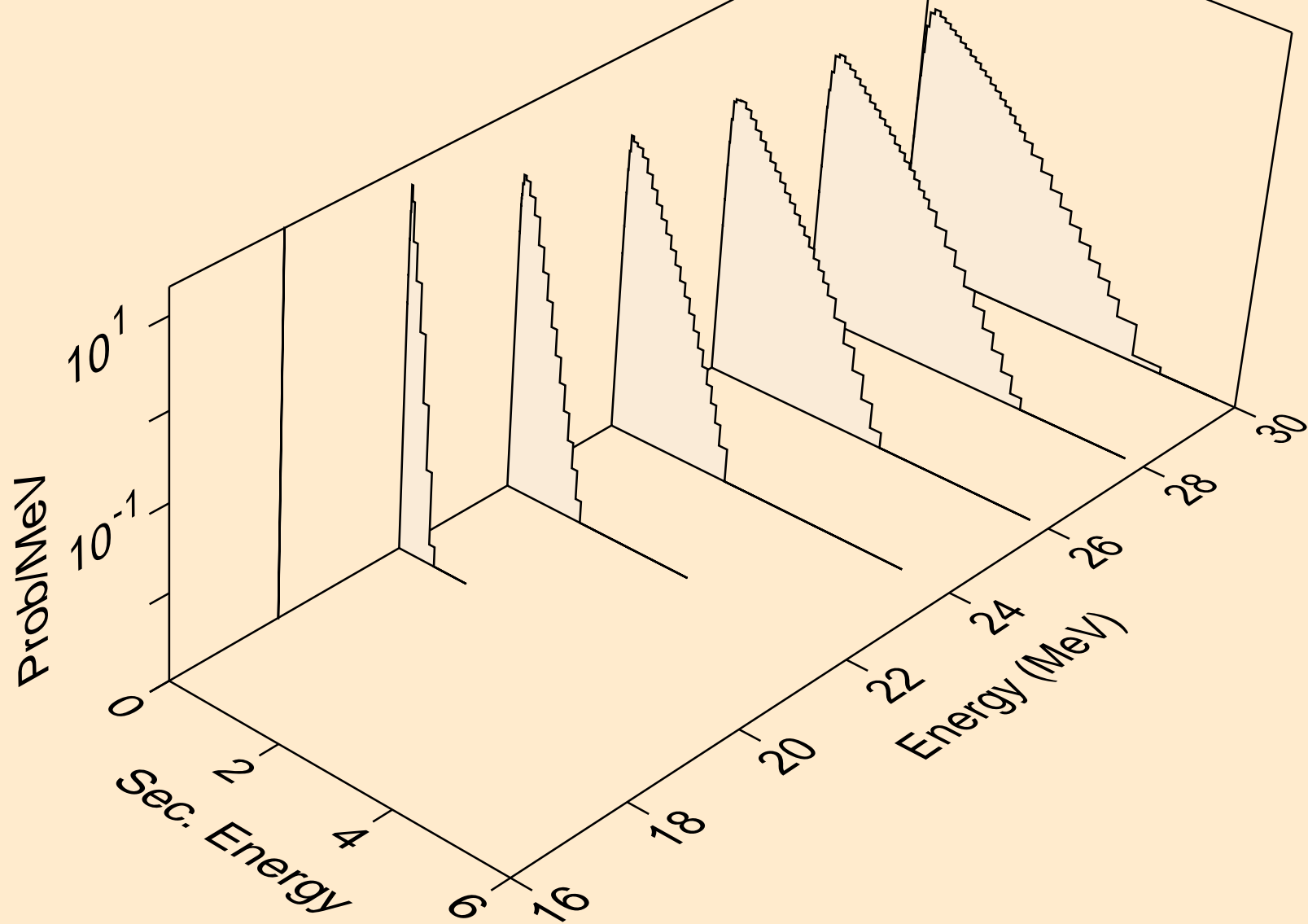

RH104M ALPHA ACER TENDL-2024 LIBRARY; T=0.K  
neutrons from (a,n\*)t

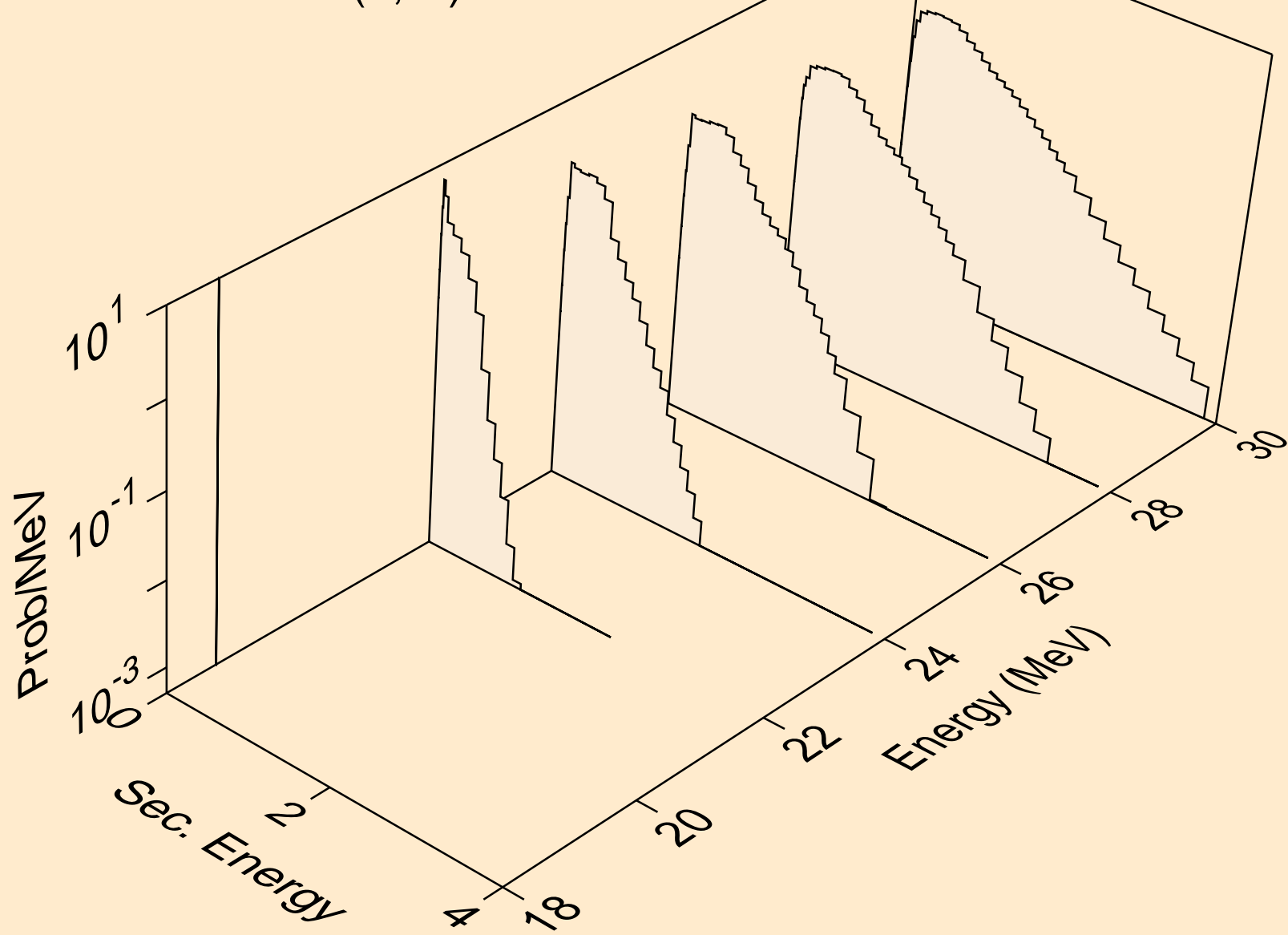

RH104M ALPHA ACER TENDL-2024 LIBRARY; T=0.K  
neutrons from (a,n\*)he3

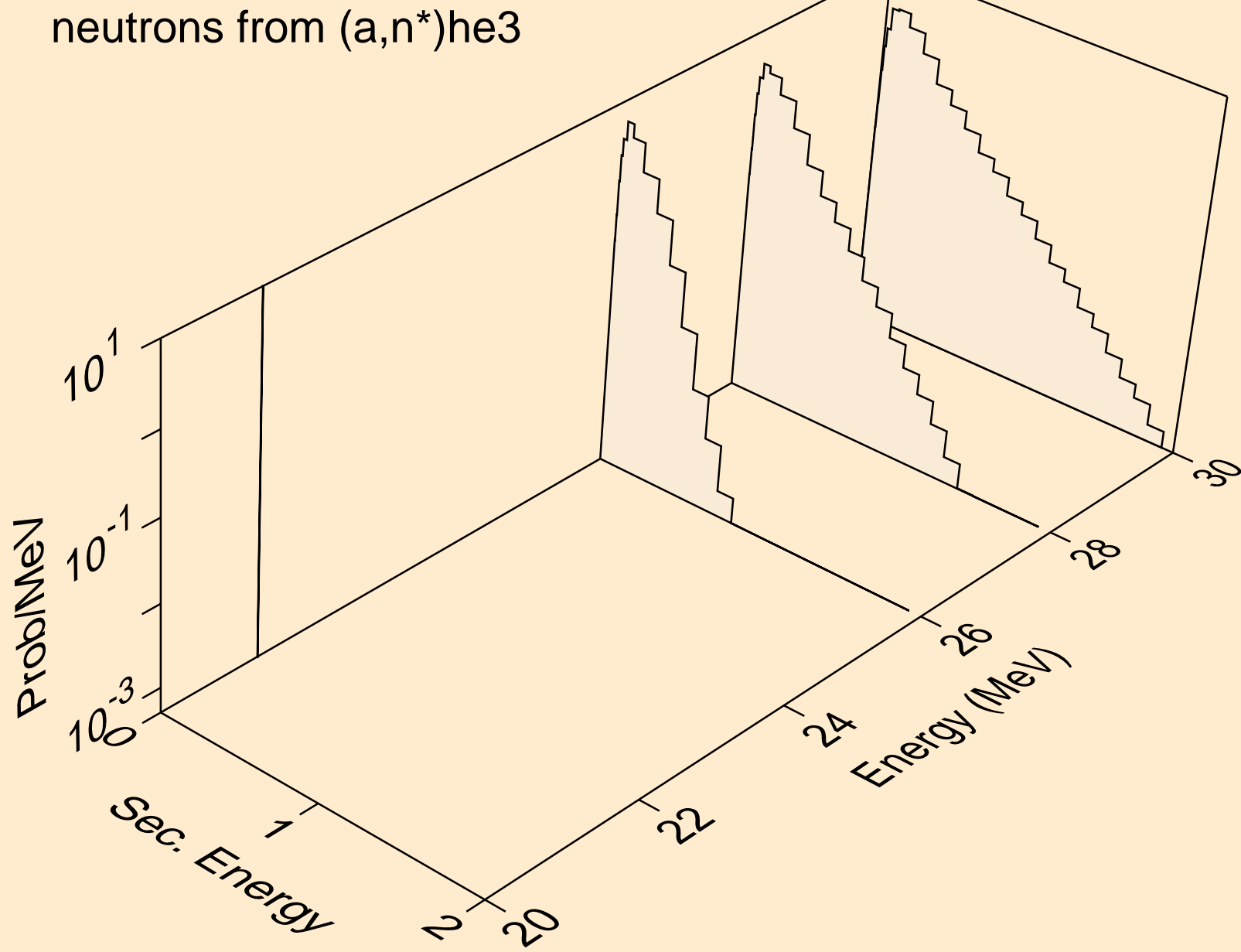

RH104M ALPHA ACER TENDL-2024 LIBRARY; T=0.K  
neutrons from (a,2np)

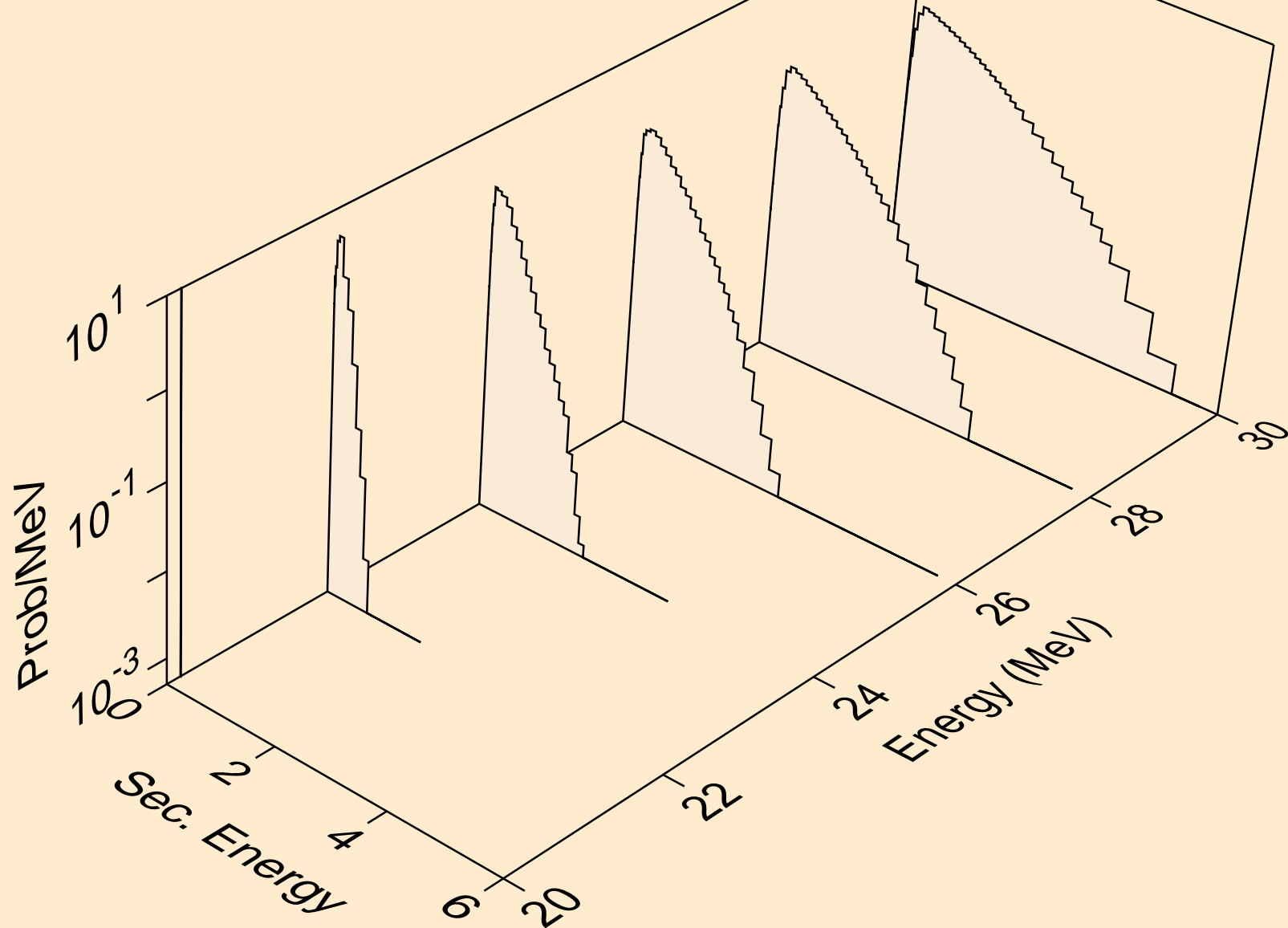

RH104M ALPHA ACER TENDL-2024 LIBRARY; T=0.K  
neutrons from (a,n2p)

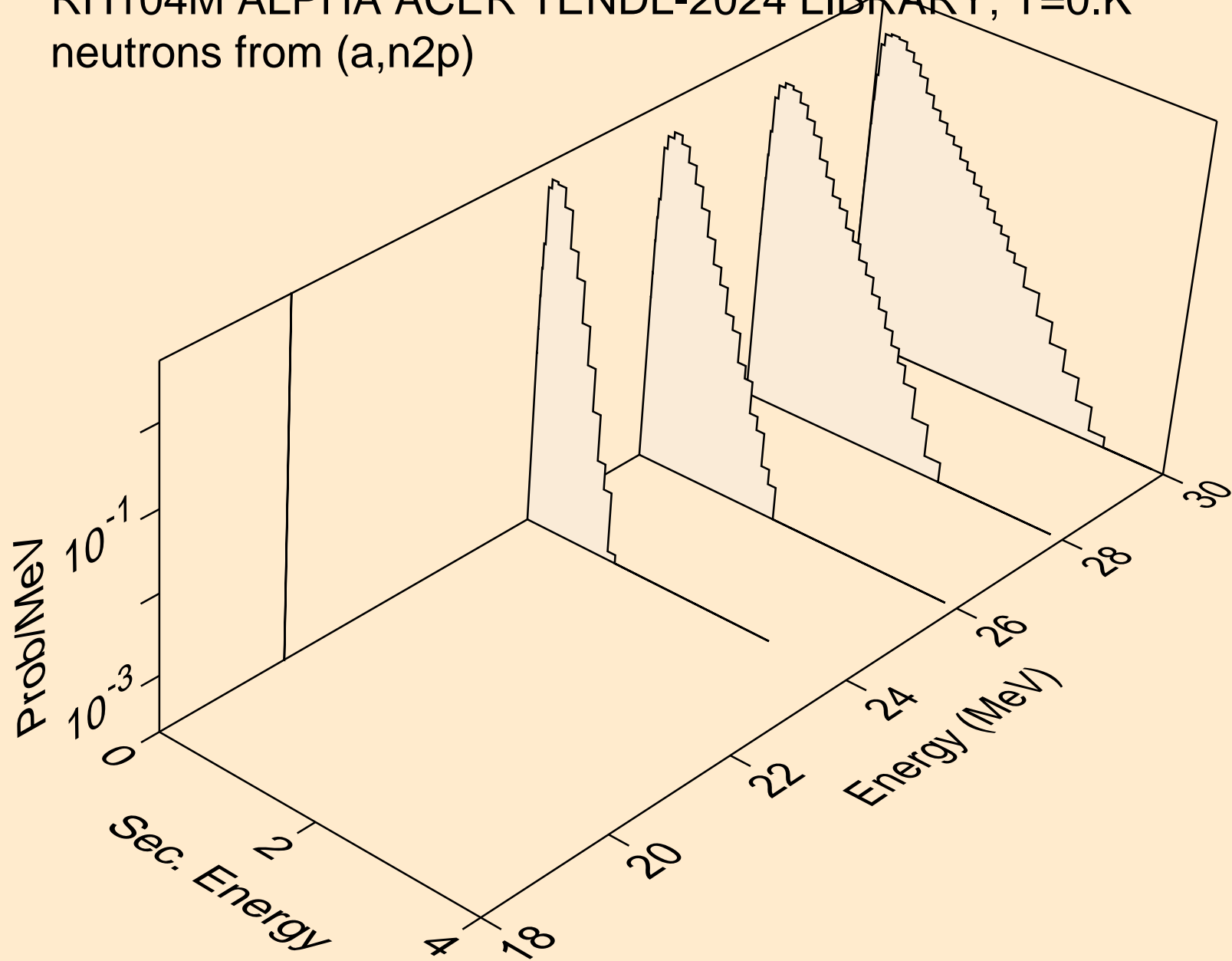

RH104M ALPHA ACER TENDL-2024 LIBRARY; T=0.K  
neutrons from (a,npa)

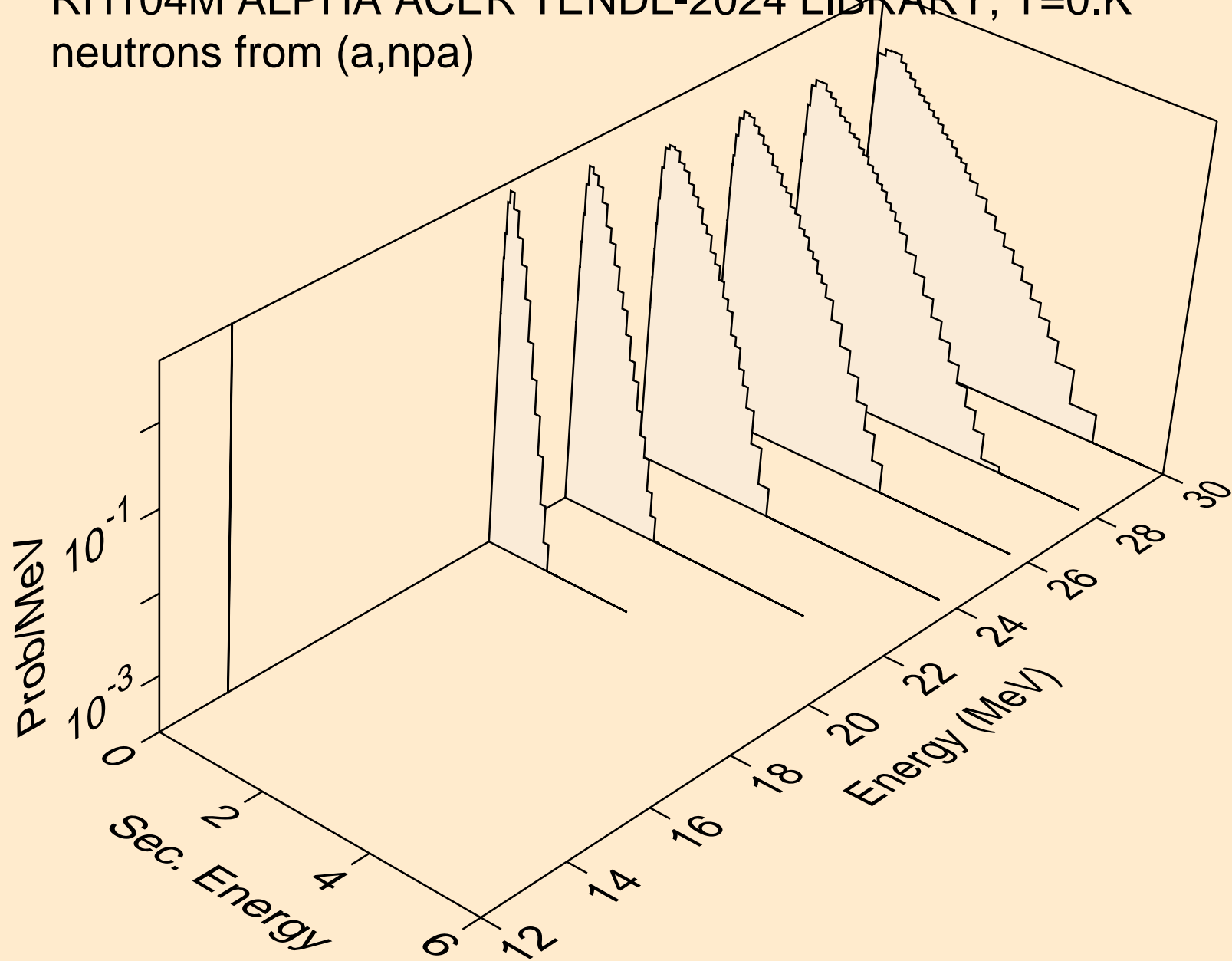

RH104M ALPHA ACER TENDL-2024 LIBRARY; T=0.K  
protons from (a,x)

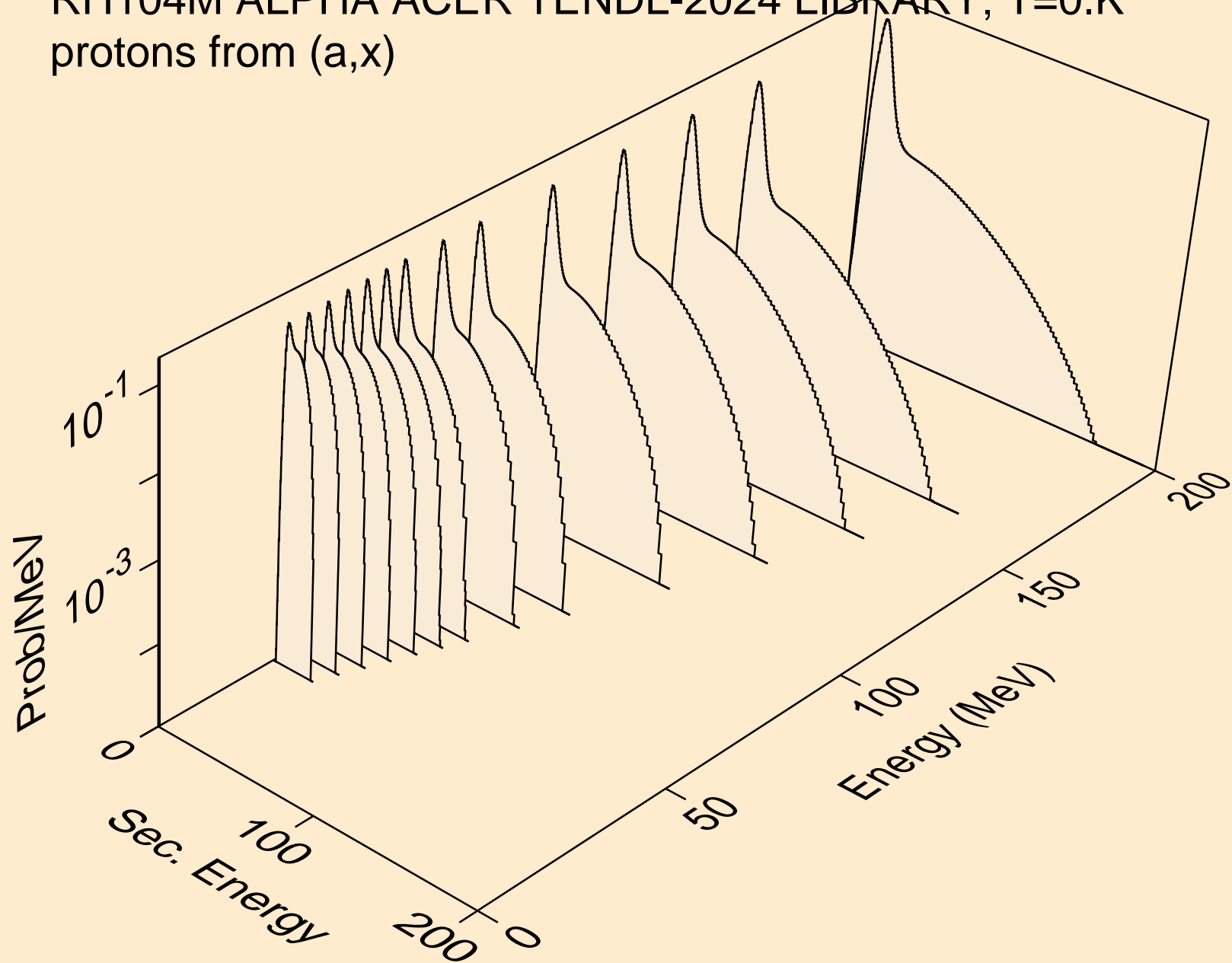

RH104M ALPHA ACER TENDL-2024 LIBRARY; T=0.K  
protons from (a,n\*)p

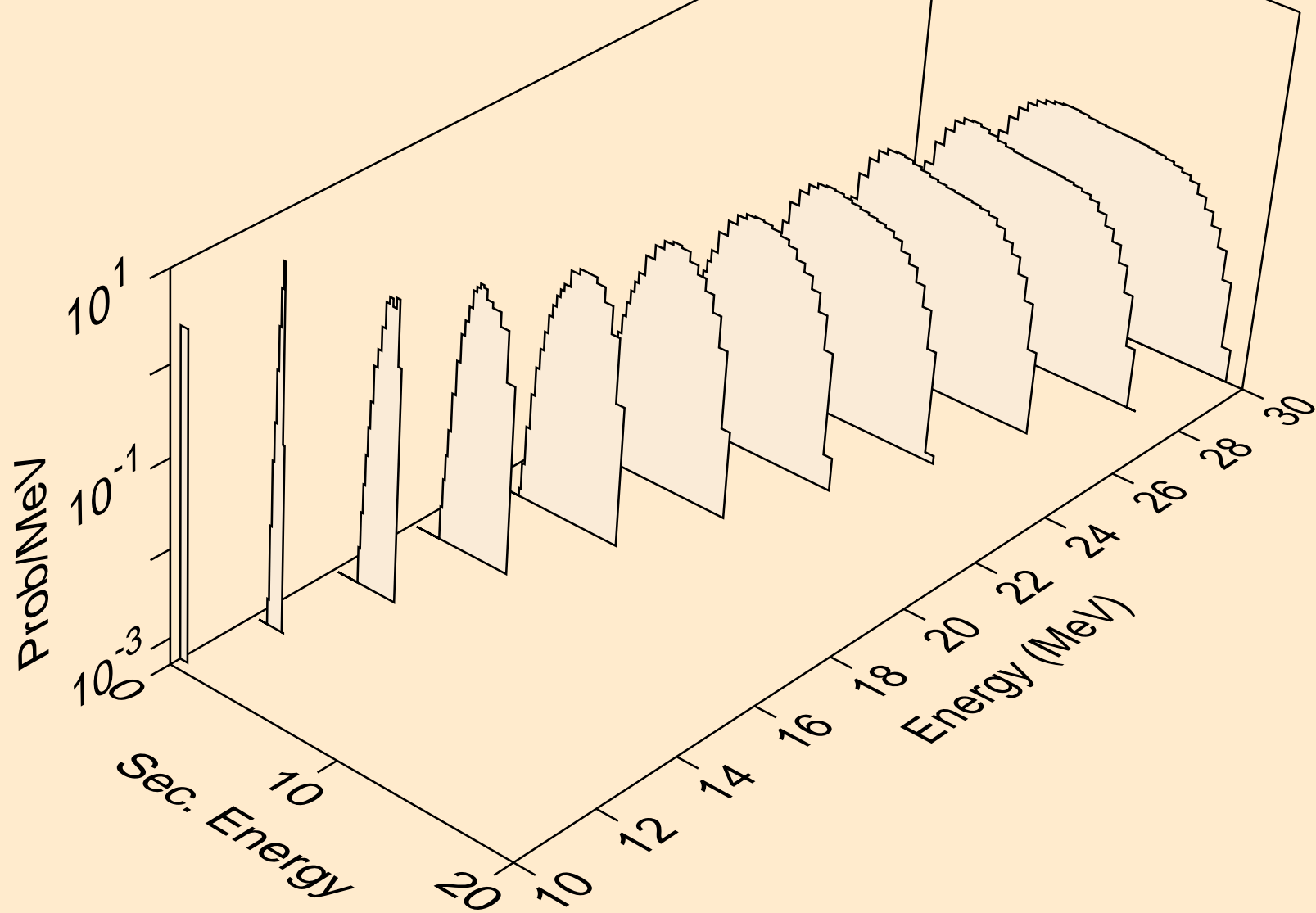

RH104M ALPHA ACER TENDL-2024 LIBRARY; T=0.K  
protons from (a,2np)

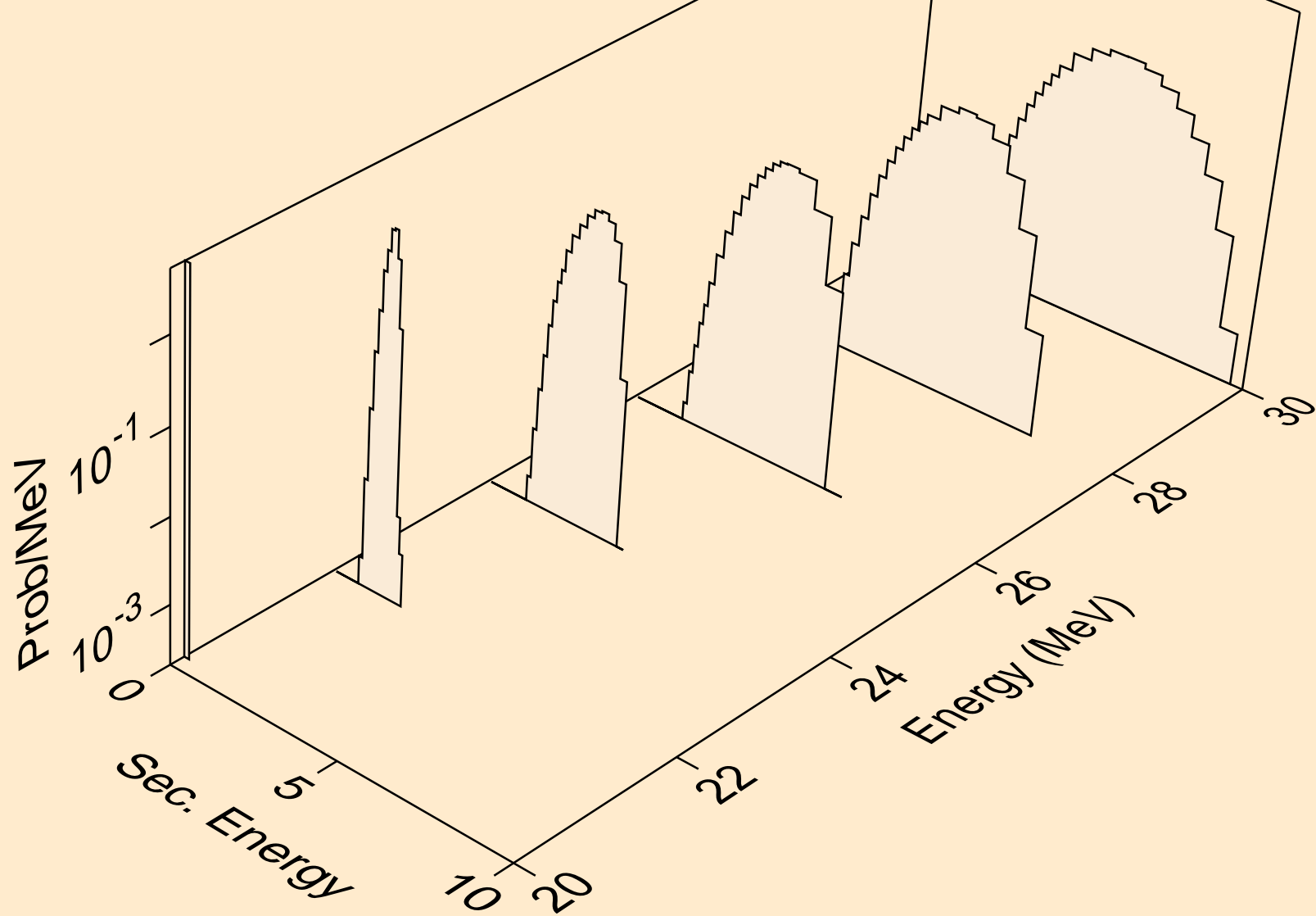

RH104M ALPHA ACER TENDL-2024 LIBRARY; T=0.K  
protons from (a,n2p)

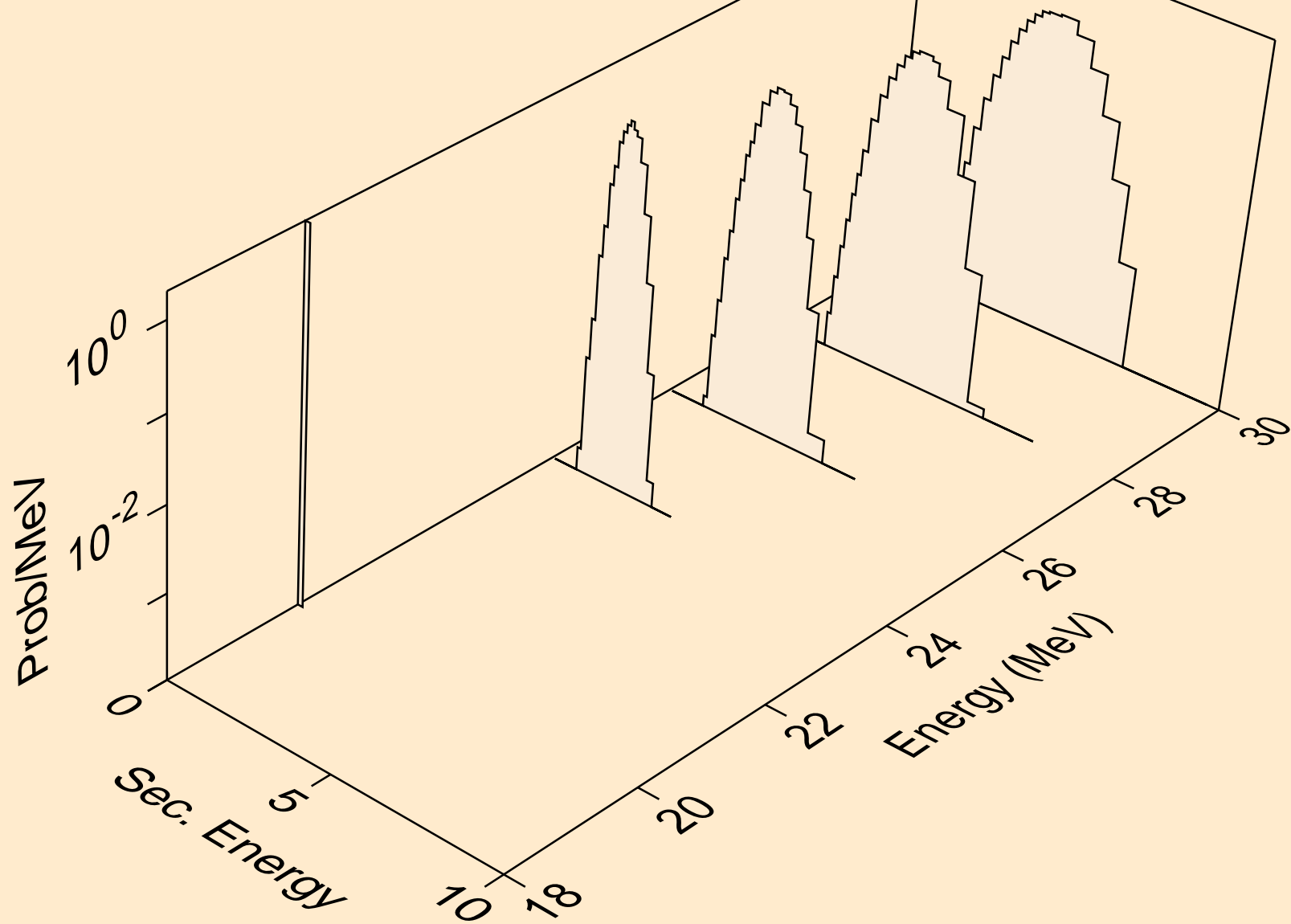

RH104M ALPHA ACER TENDL-2024 LIBRARY; T=0.K  
protons from (a,npa)

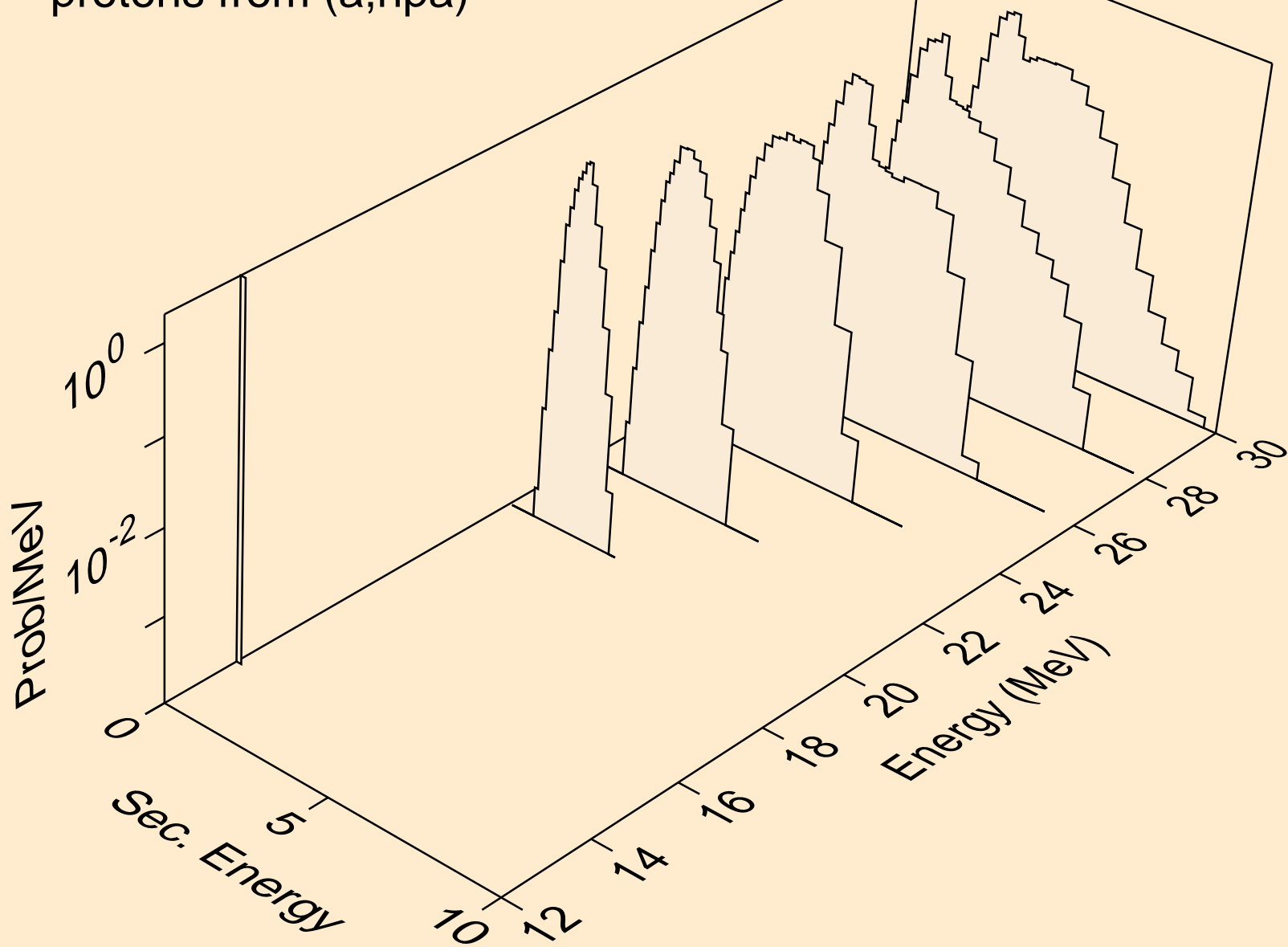

RH104M ALPHA ACER TENDL-2024 LIBRARY; T=0.K  
protons from (a,p)

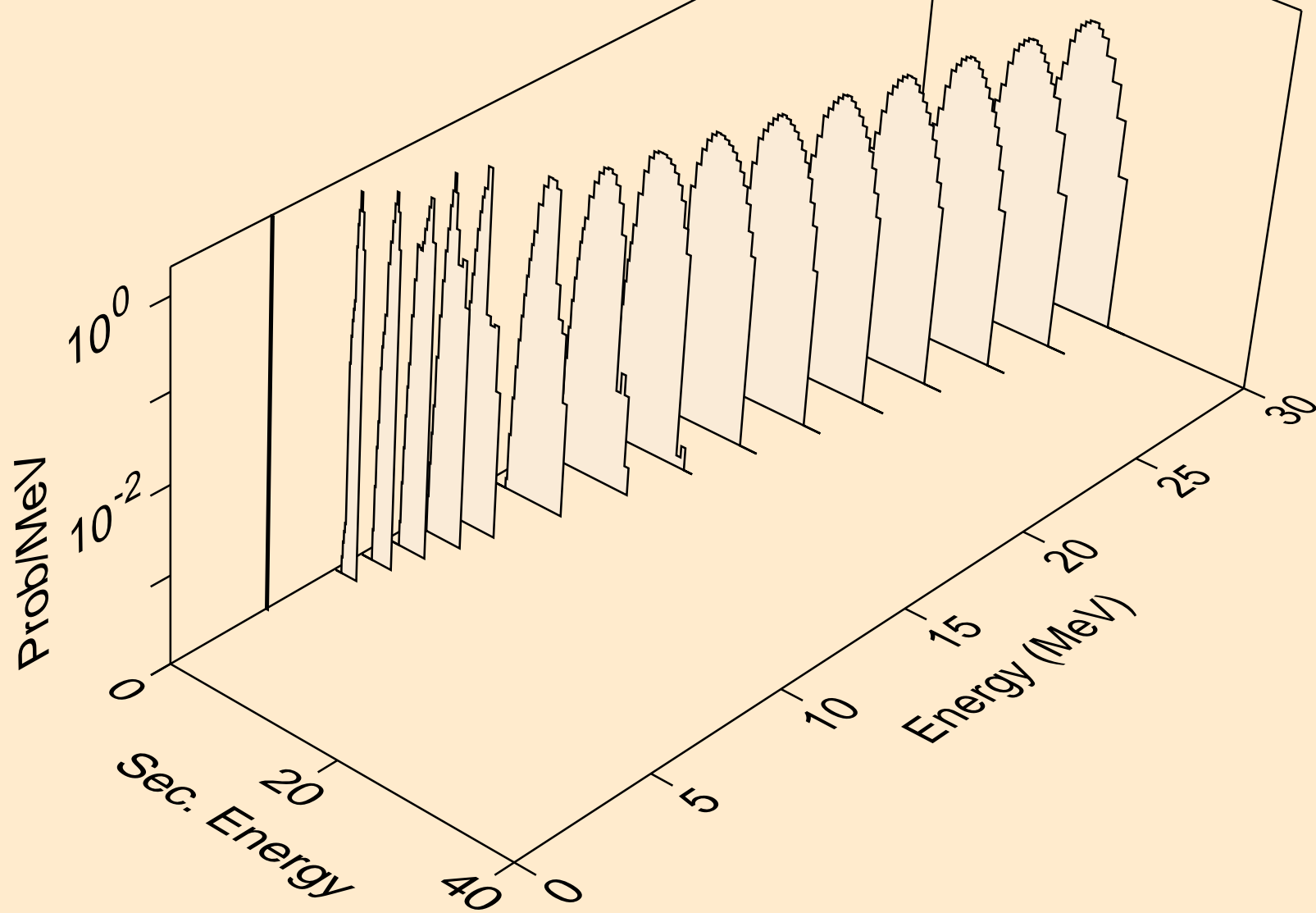

RH104M ALPHA ACER TENDL-2024 LIBRARY; T=0.K  
protons from (a,2p)

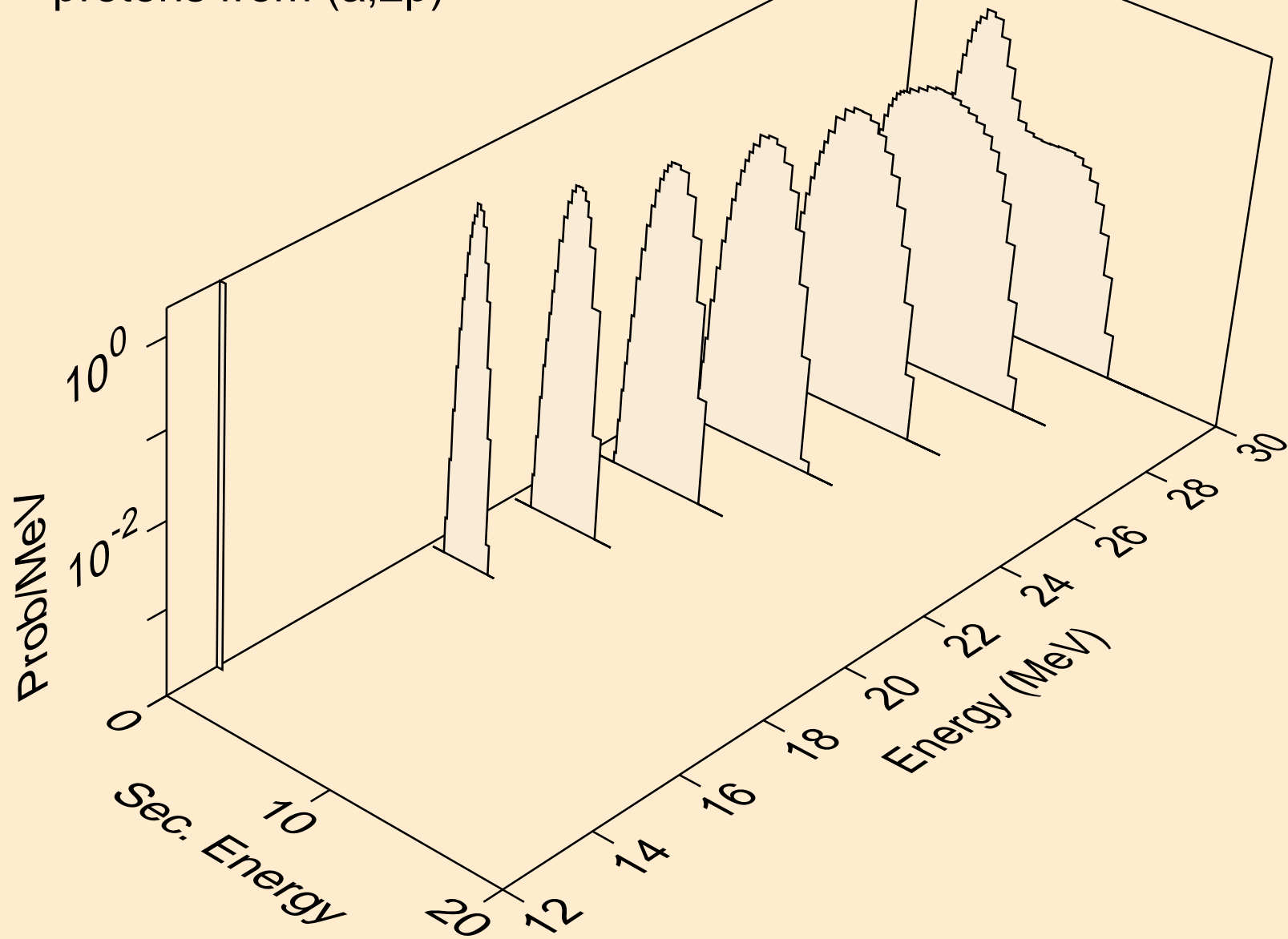

RH104M ALPHA ACER TENDL-2024 LIBRARY; T=0.K  
protons from (a,pa)

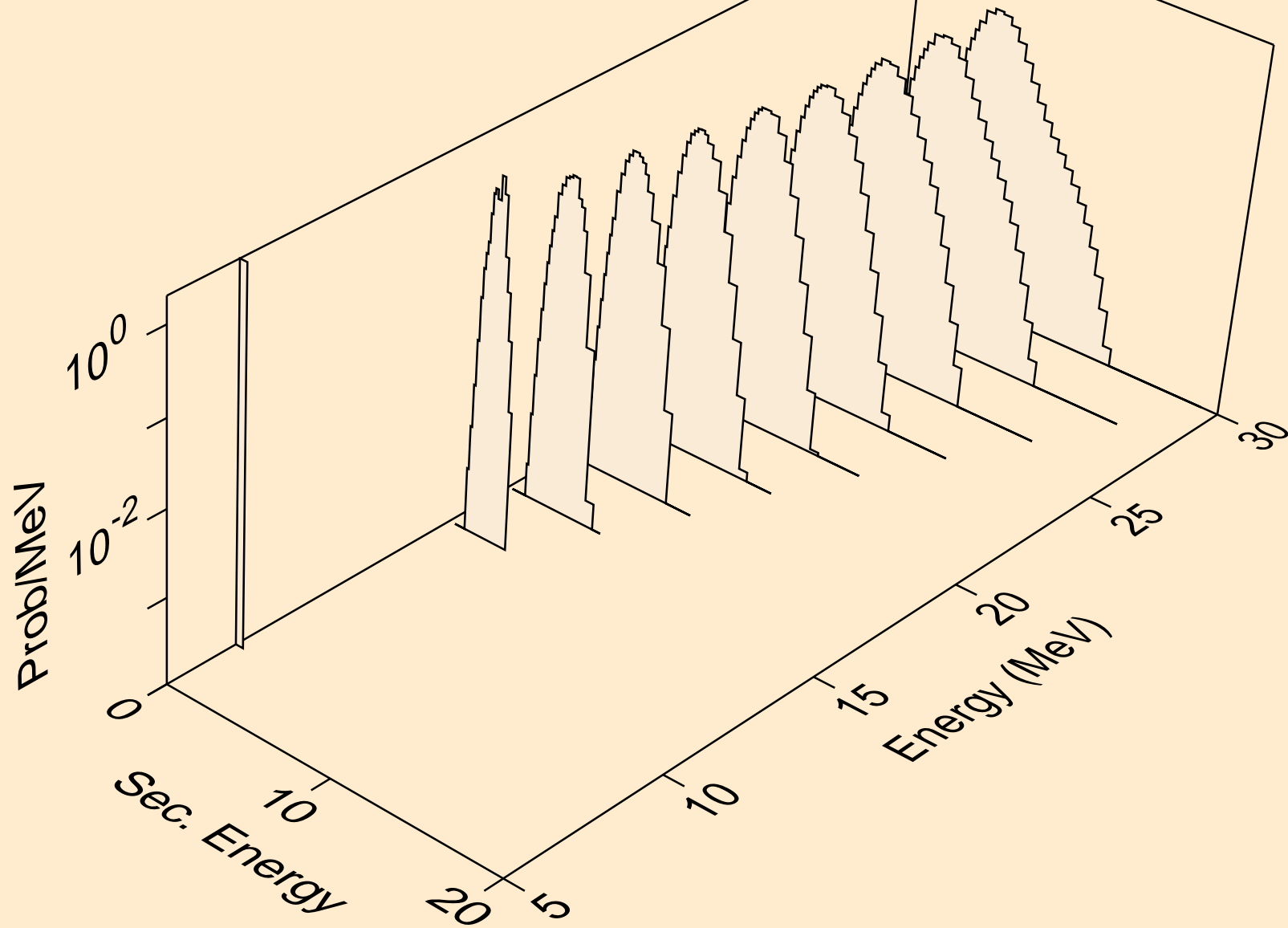

RH104M ALPHA ACER TENDL-2024 LIBRARY; T=0.K  
protons from (a,pd)

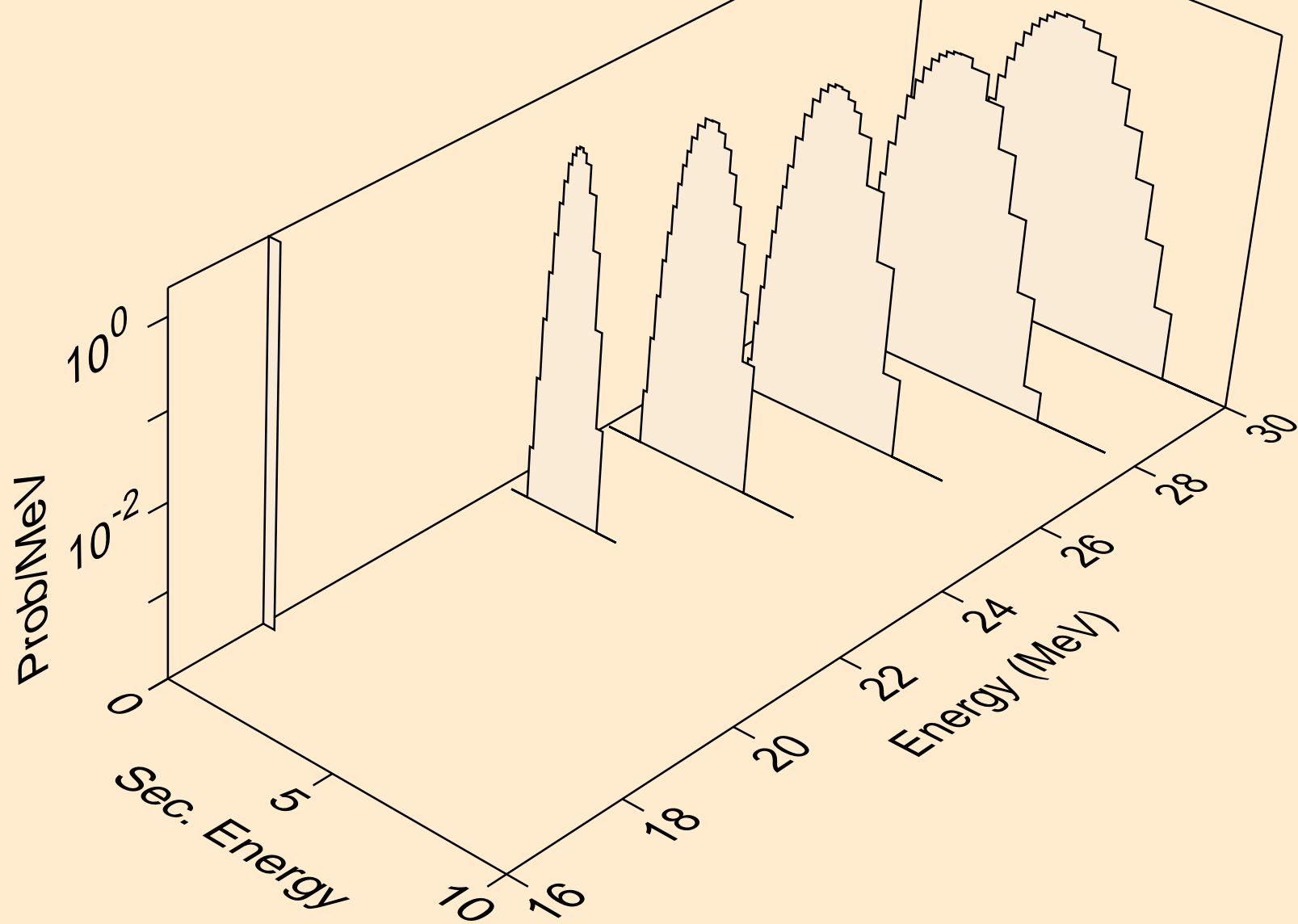

RH104M ALPHA ACER TENDL-2024 LIBRARY; T=0.K  
deuterons from (a,x)

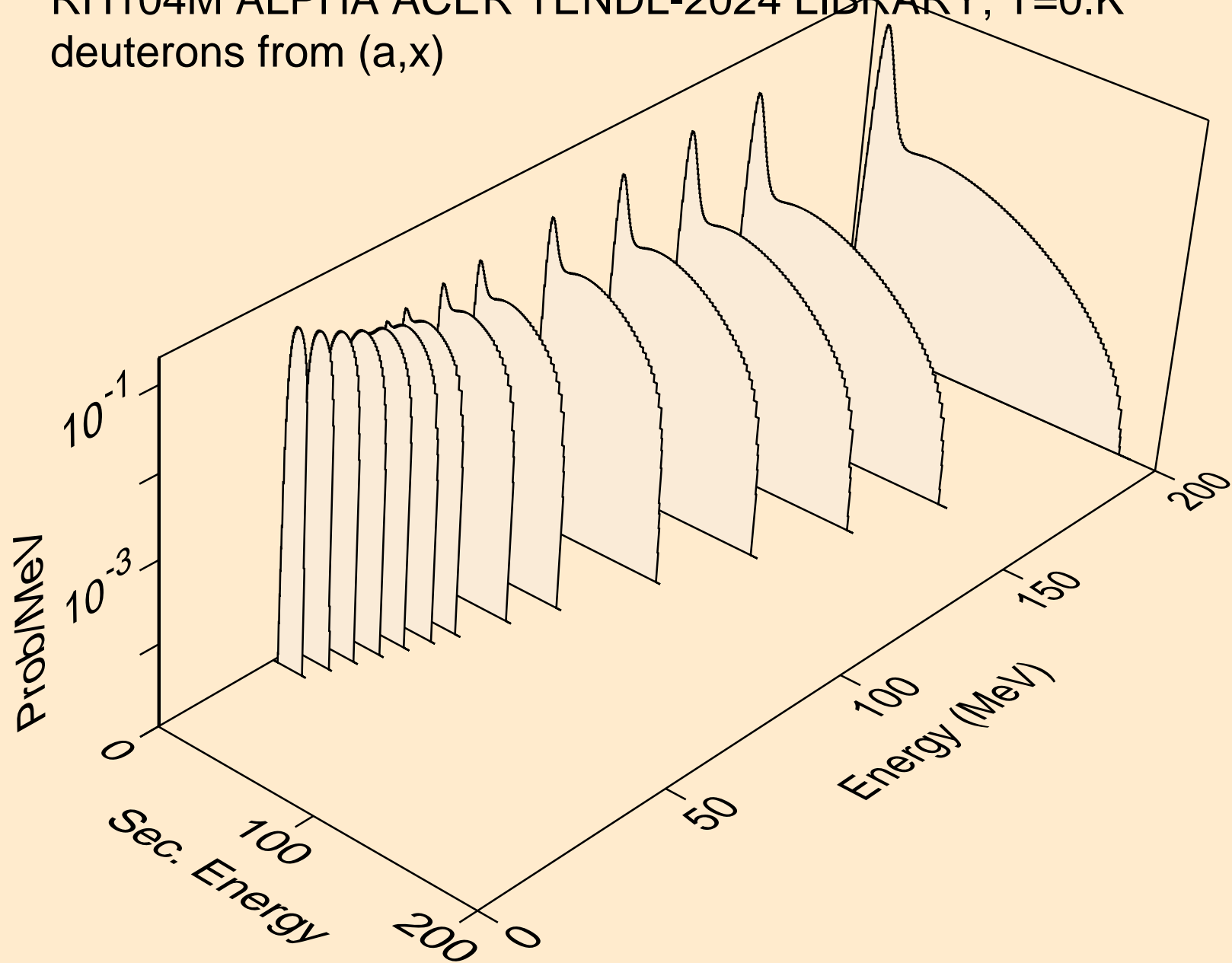

RH104M ALPHA ACER TENDL-2024 LIBRARY; T=0.K  
deuterons from (a,2nd)

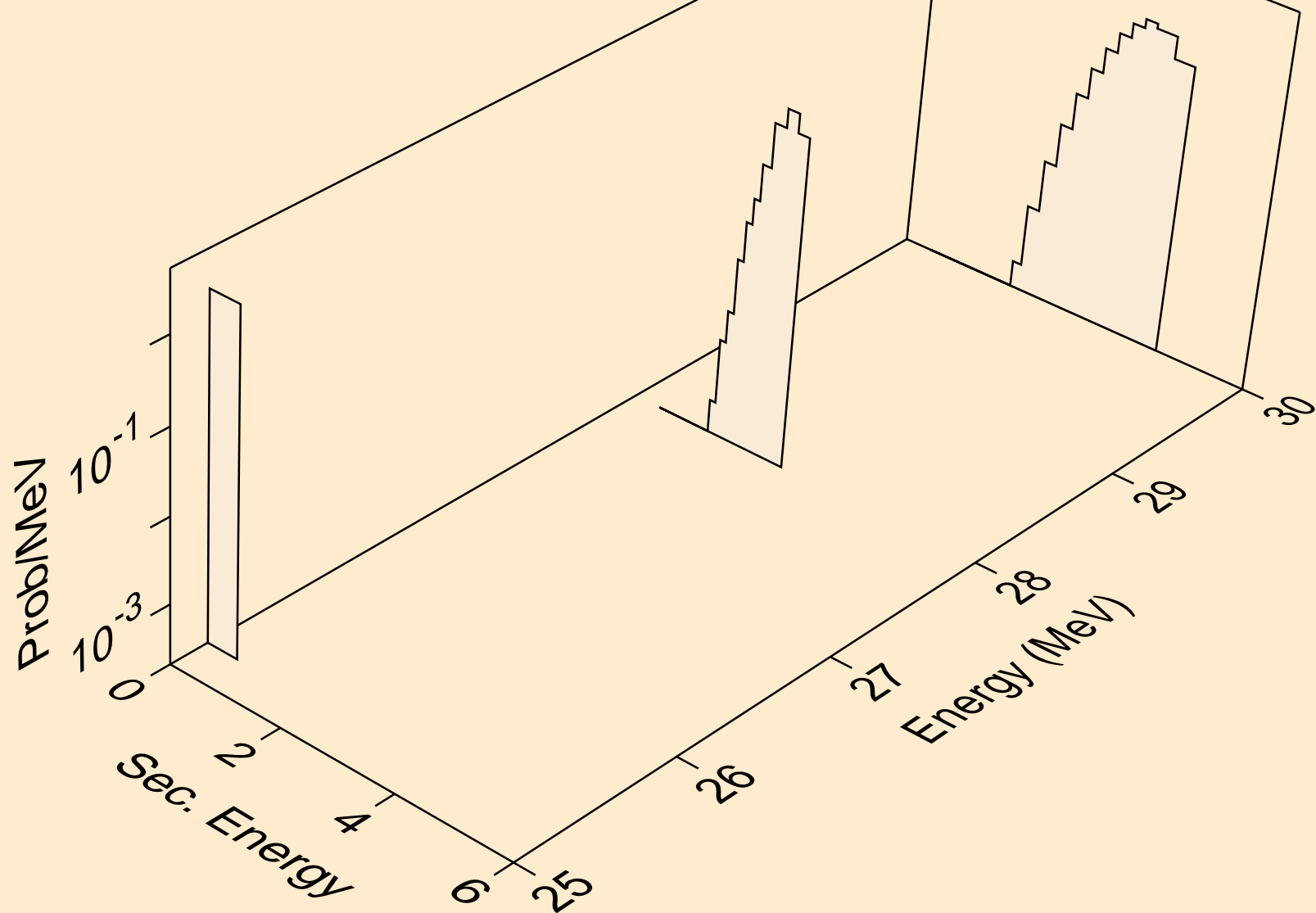

RH104M ALPHA ACER TENDL-2024 LIBRARY; T=0.K  
deuterons from (a,n\*)d

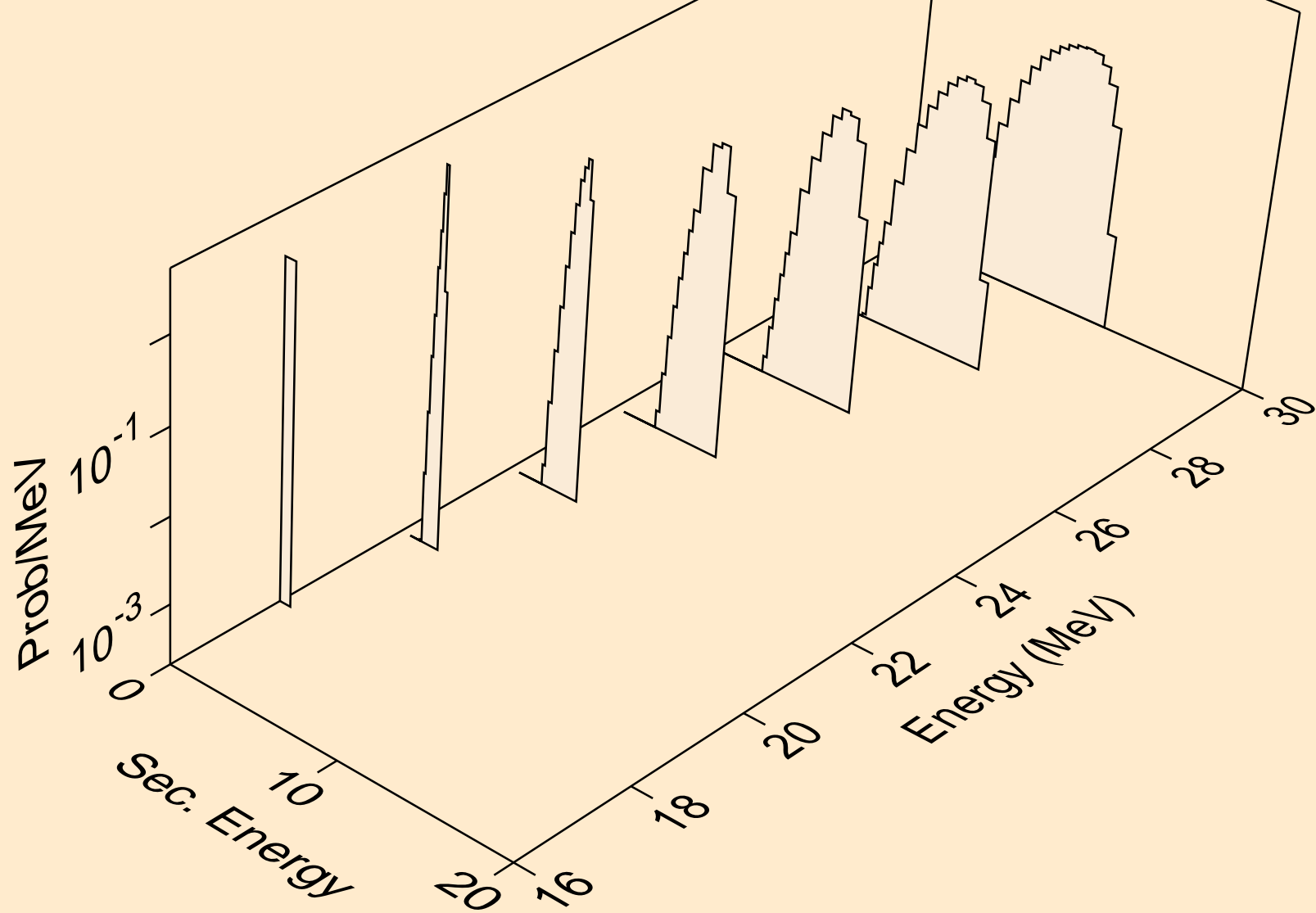

RH104M ALPHA ACER TENDL-2024 LIBRARY; T=0.K  
deuterons from (a,d)

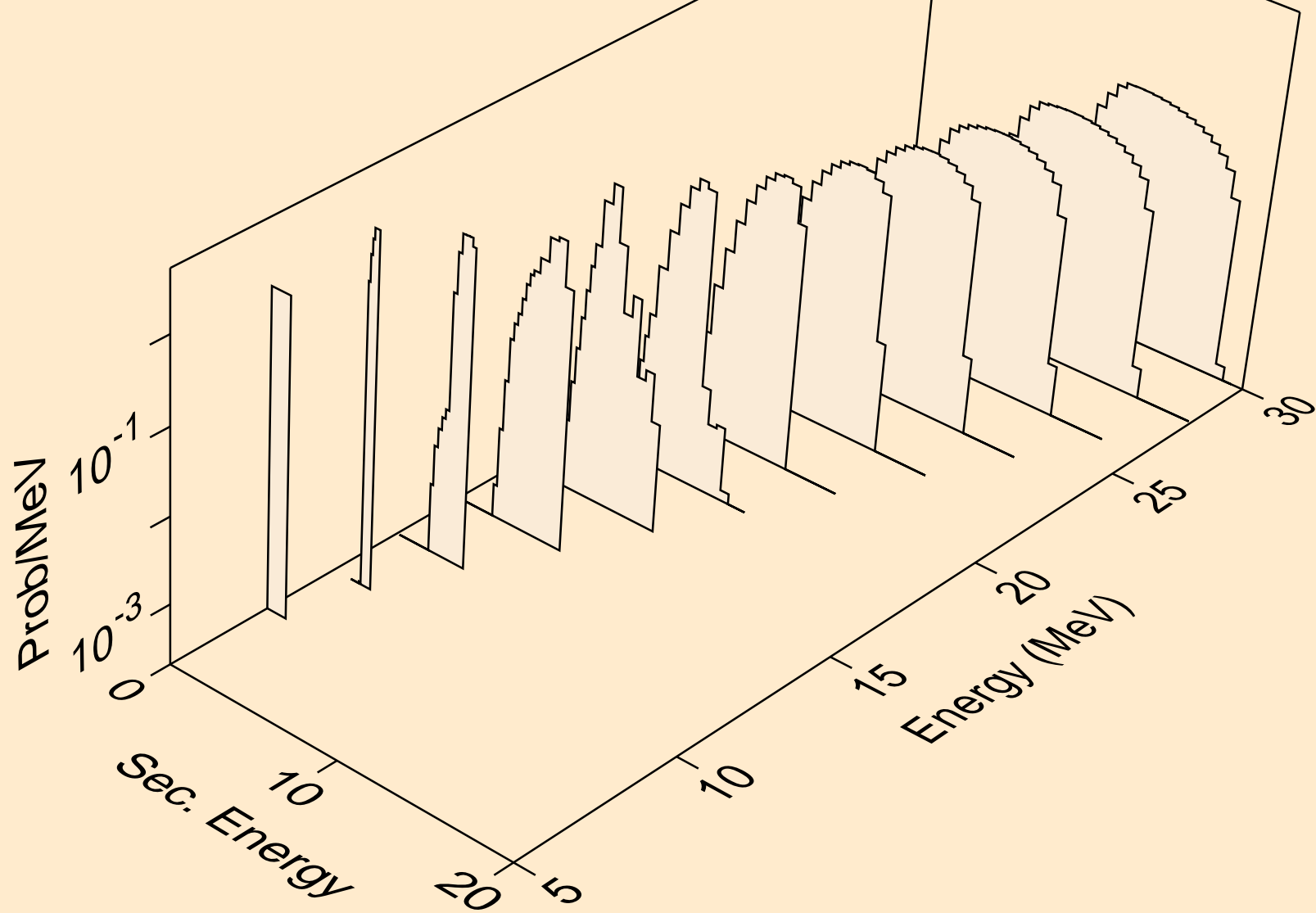

RH104M ALPHA ACER TENDL-2024 LIBRARY; T=0.K  
deuterons from (a,pd)

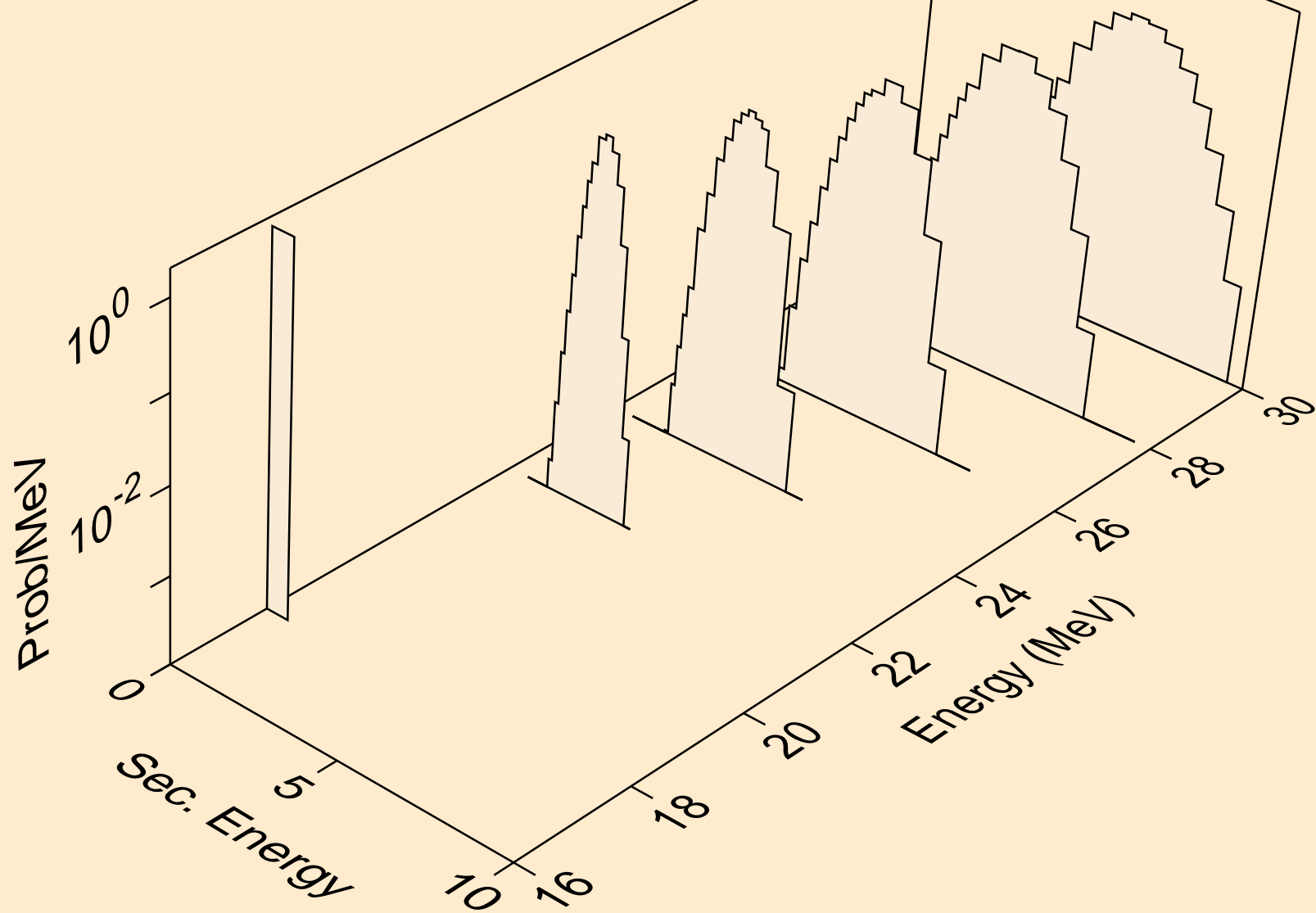

RH104M ALPHA ACER TENDL-2024 LIBRARY; T=0.K  
deuterons from (a,da)

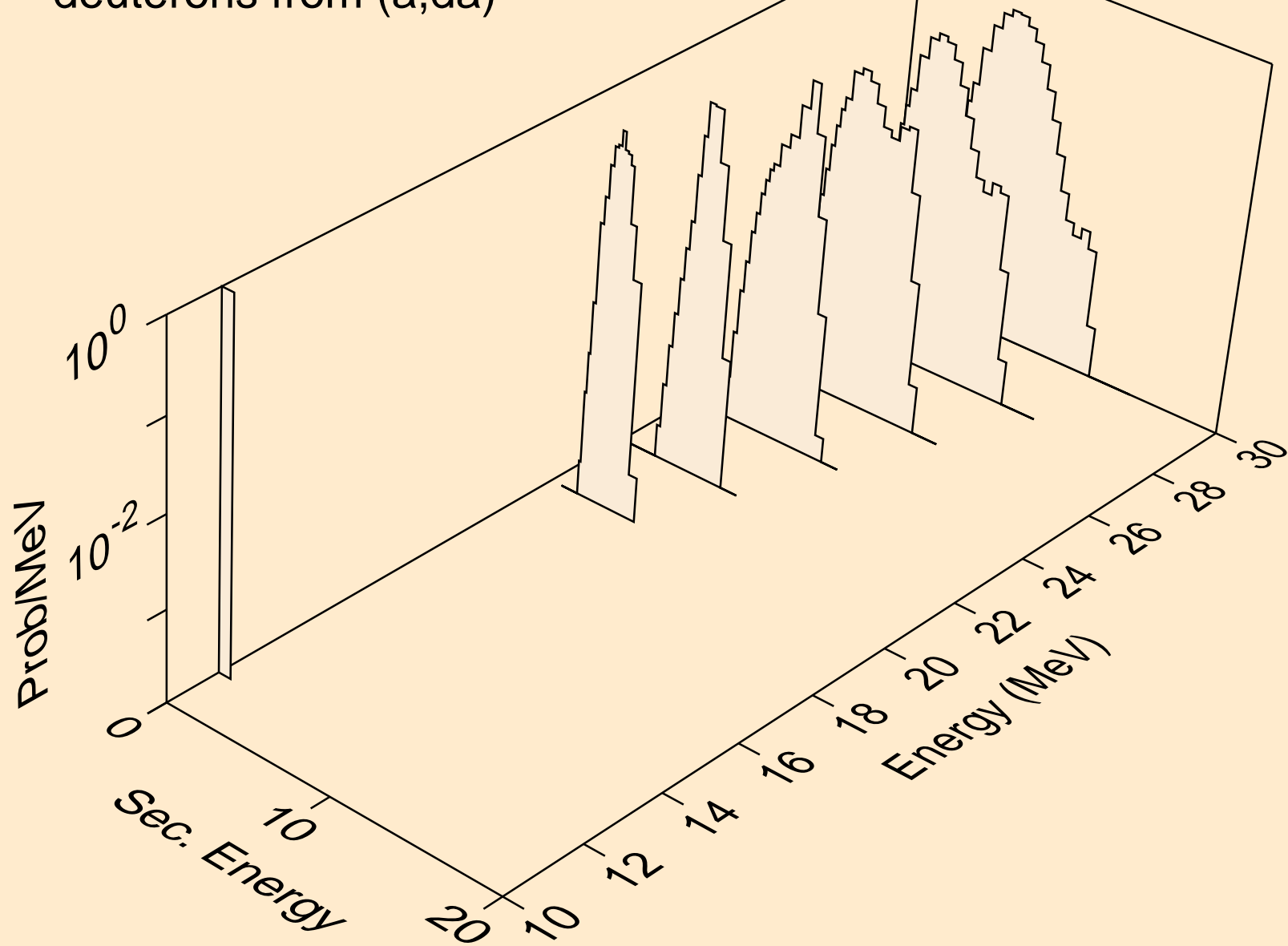

RH104M ALPHA ACER TENDL-2024 LIBRARY; T=0.K  
tritons from (a,x)

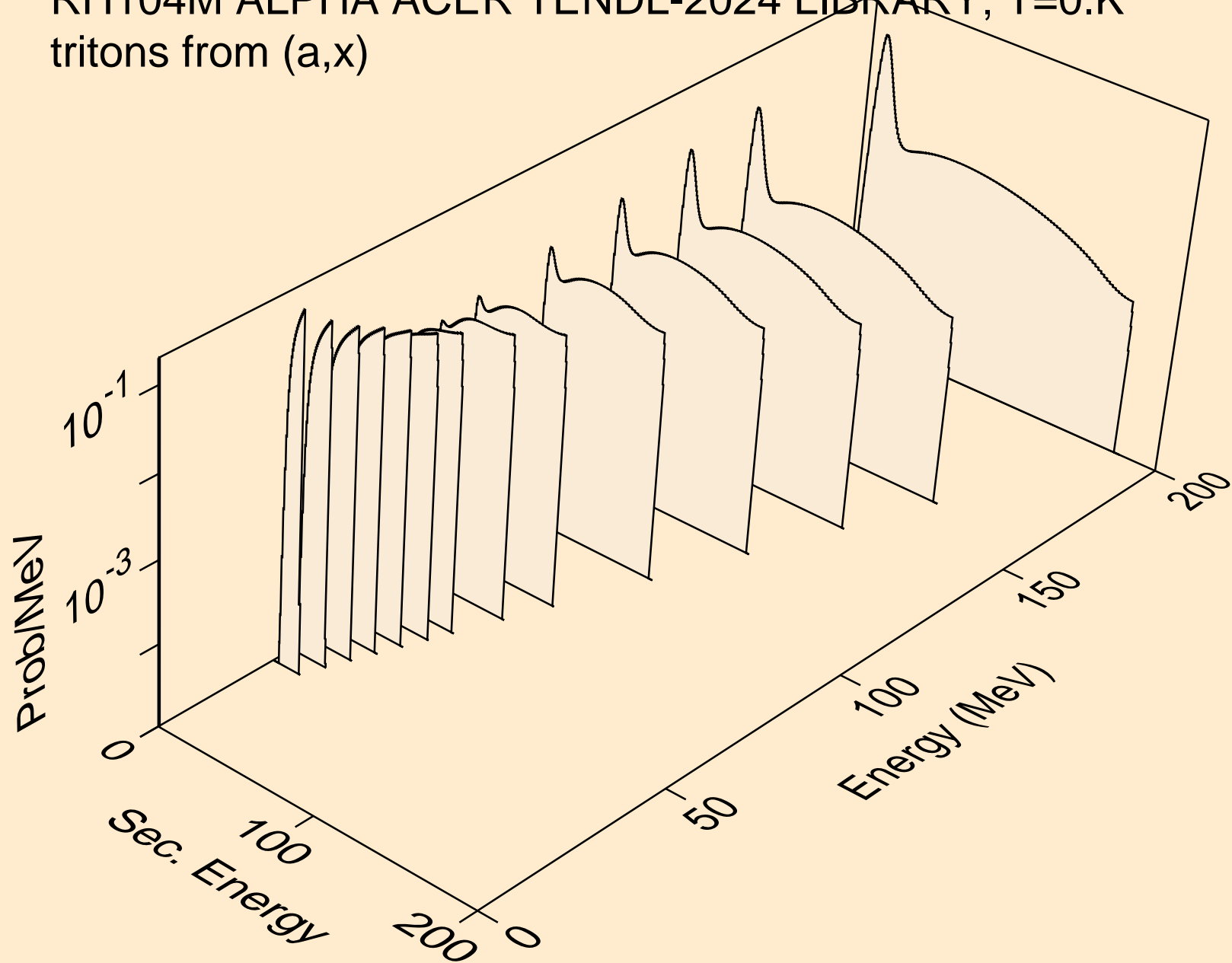

RH104M ALPHA ACER TENDL-2024 LIBRARY; T=0.K  
tritons from (a,n\*)t

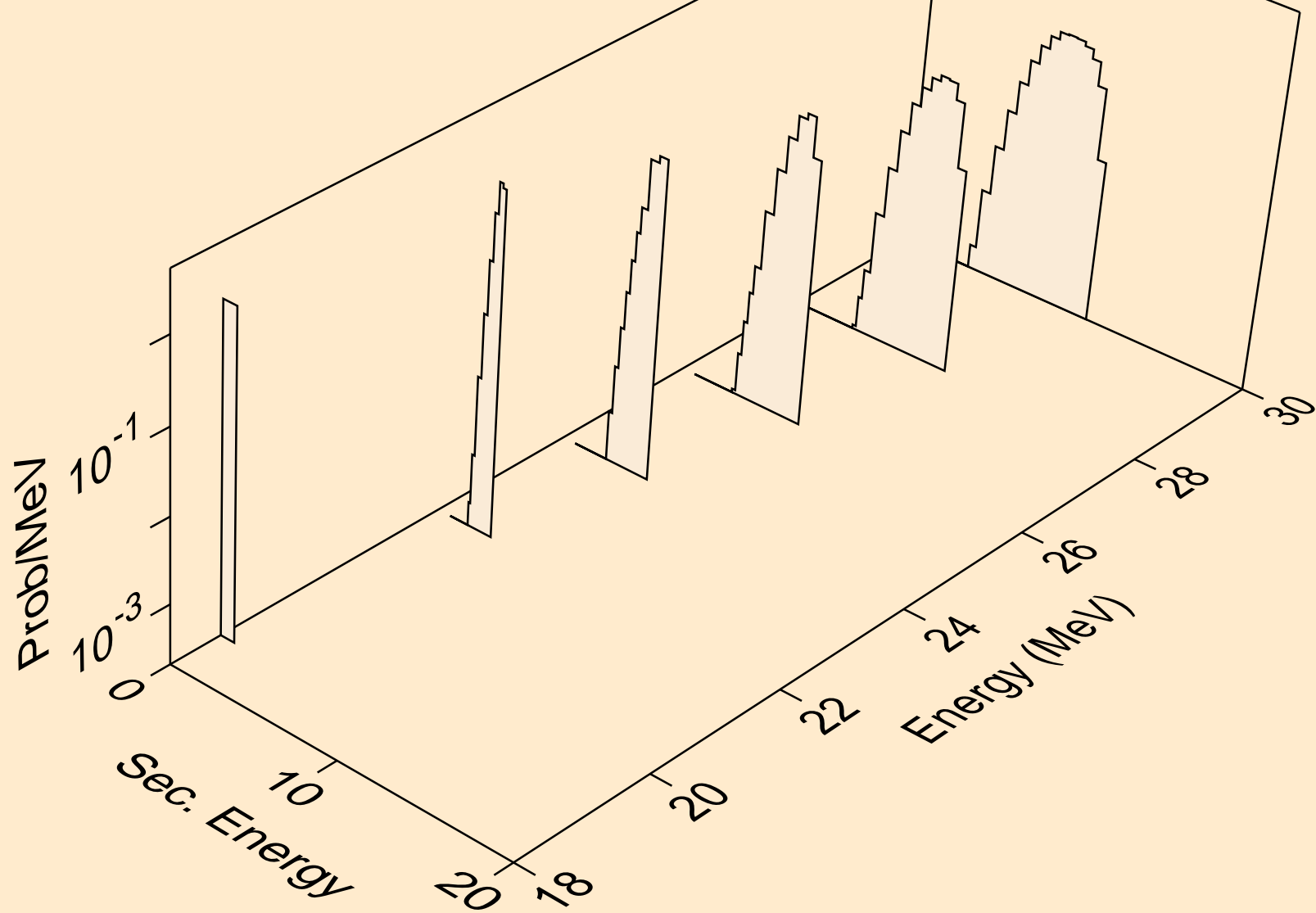

RH104M ALPHA ACER TENDL-2024 LIBRARY; T=0.K  
tritons from (a,t)

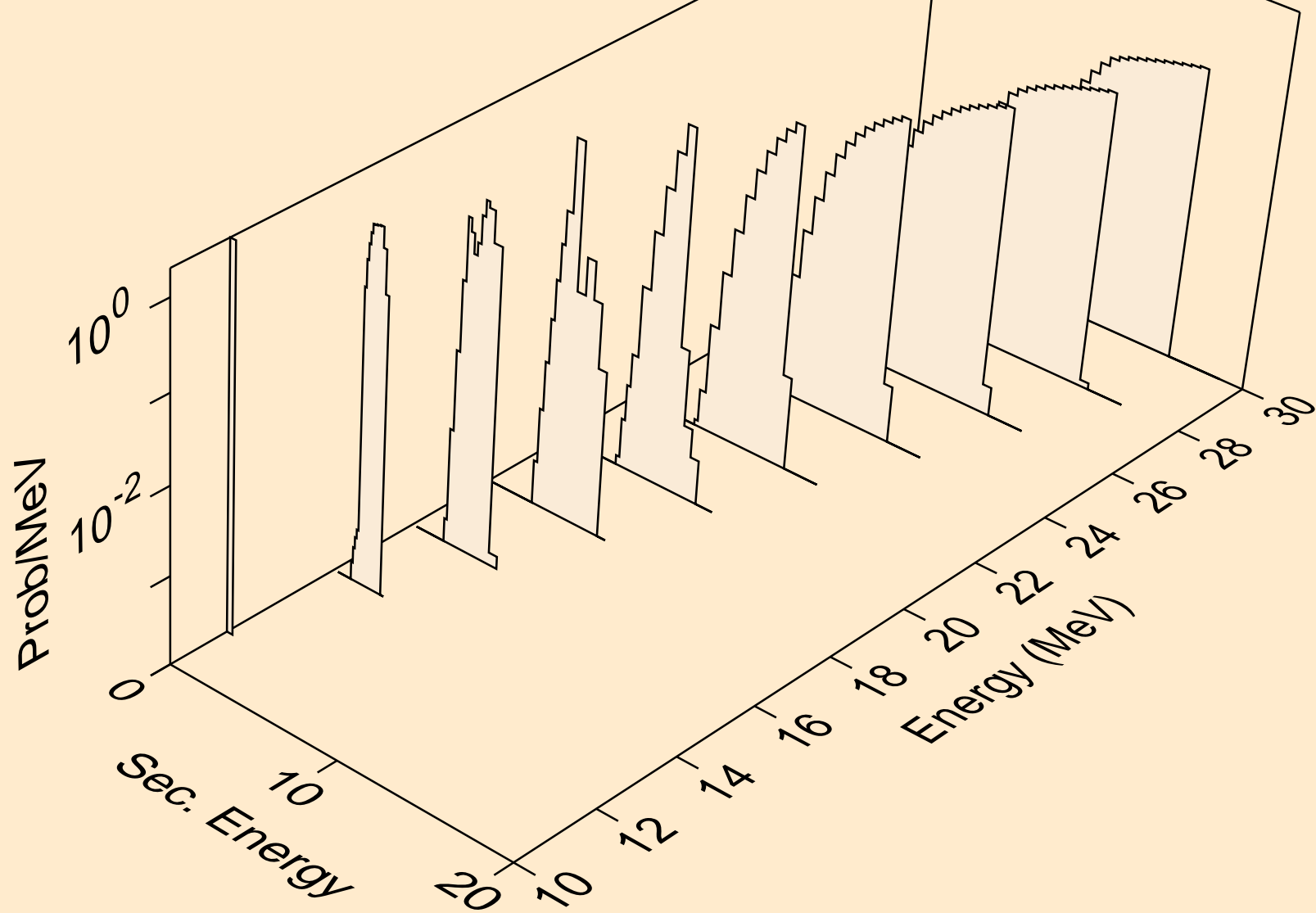

RH104M ALPHA ACER TENDL-2024 LIBRARY; T=0.K  
he3s from (a,x)

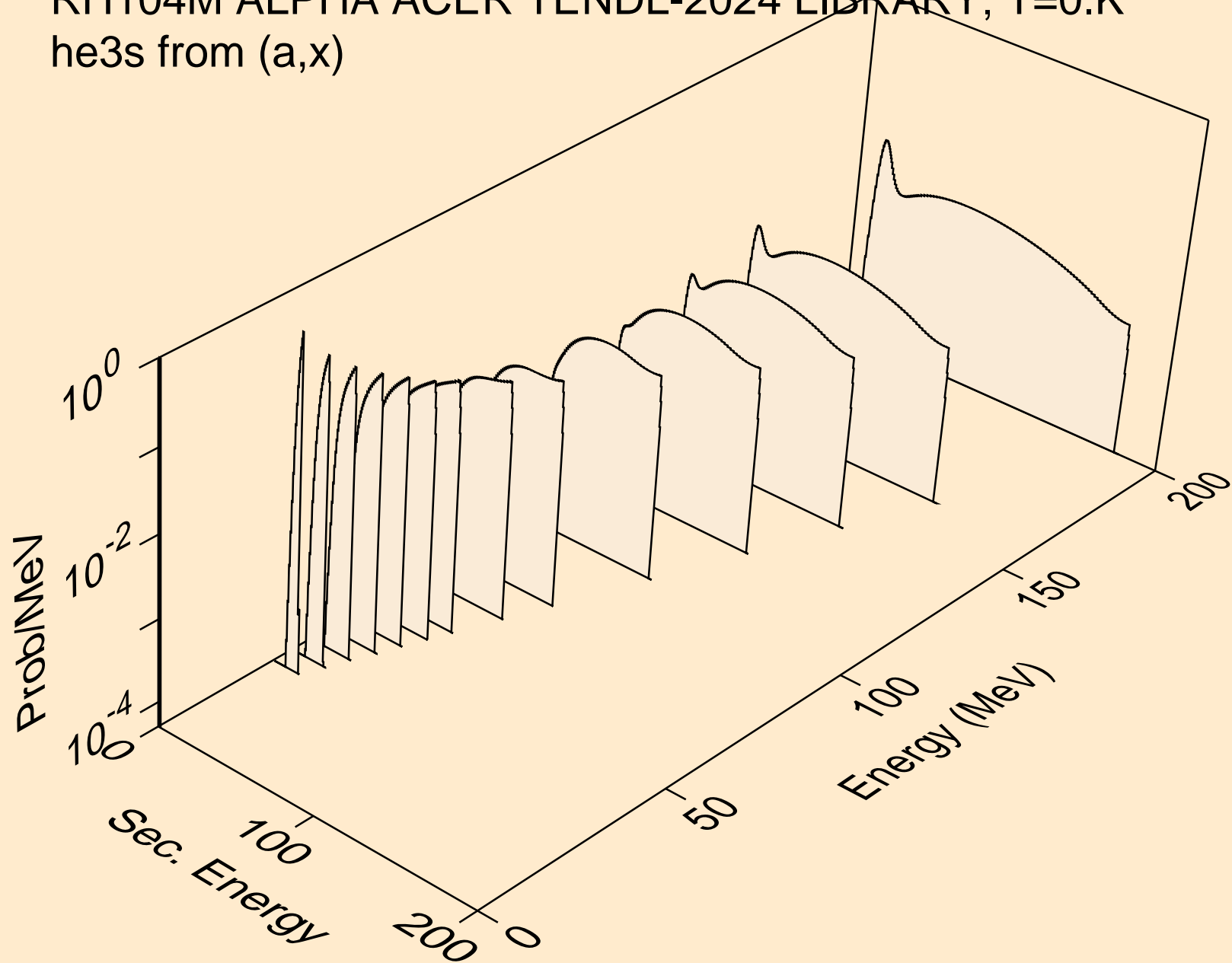

RH104M ALPHA ACER TENDL-2024 LIBRARY; T=0.K  
he3s from (a,n\*)he3

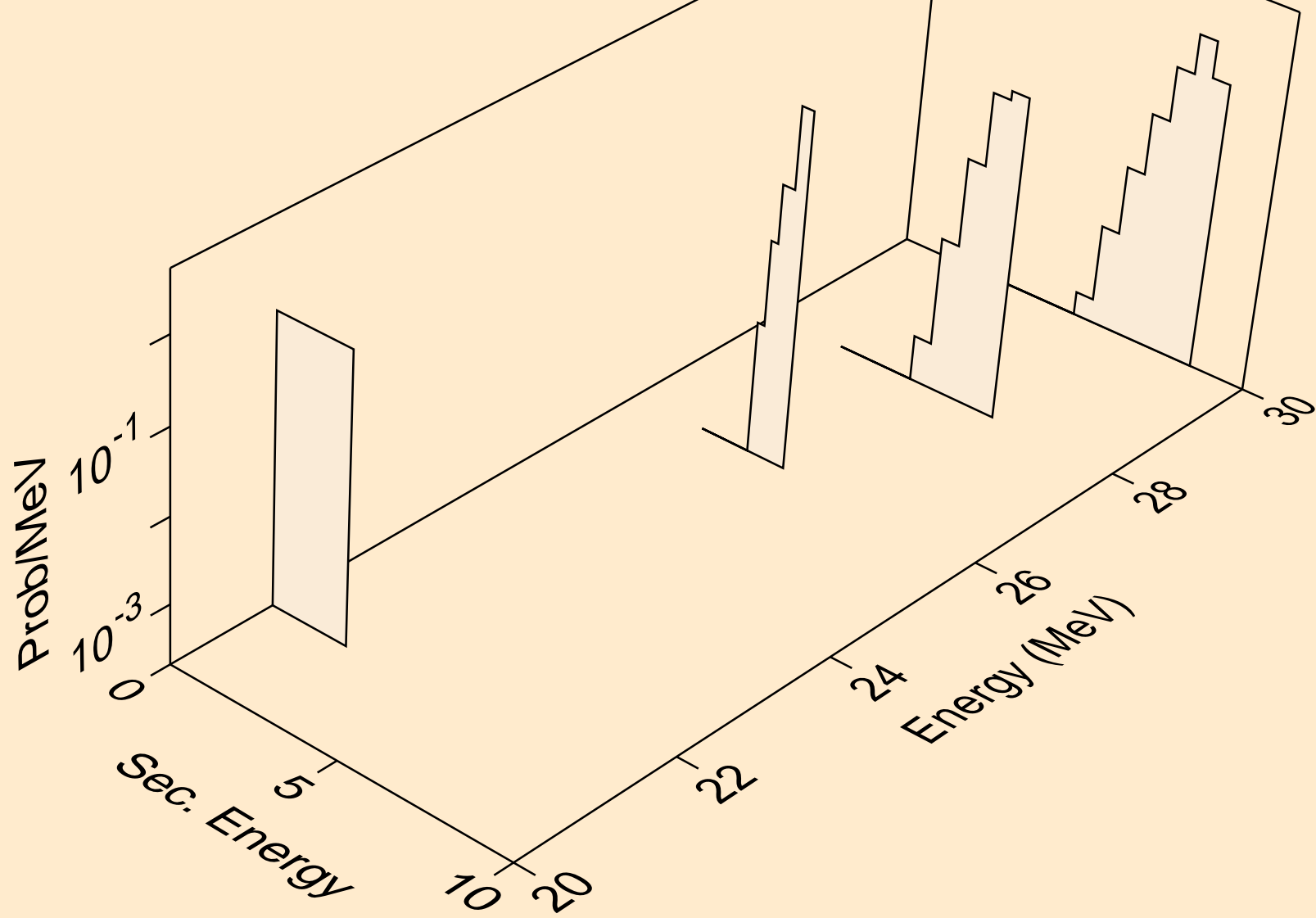

RH104M ALPHA ACER TENDL-2024 LIBRARY; T=0.K  
he3s from (a,he3)

