

RH106 ALPHA ACER TENDL-2024 LIBRARY; T=0.K
Principal cross sections

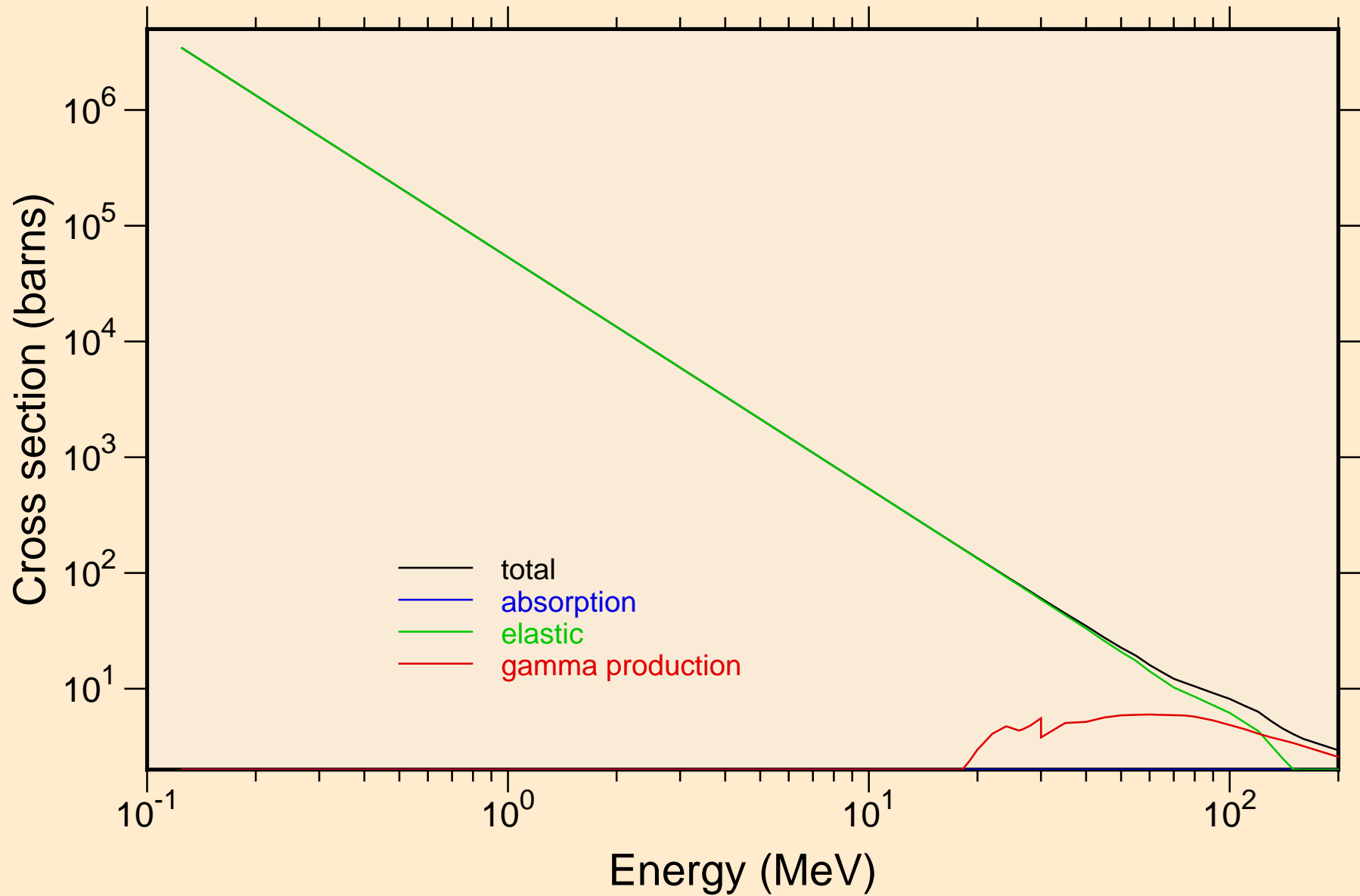

RH106 ALPHA ACER TENDL-2024 LIBRARY; T=0.K
Heating

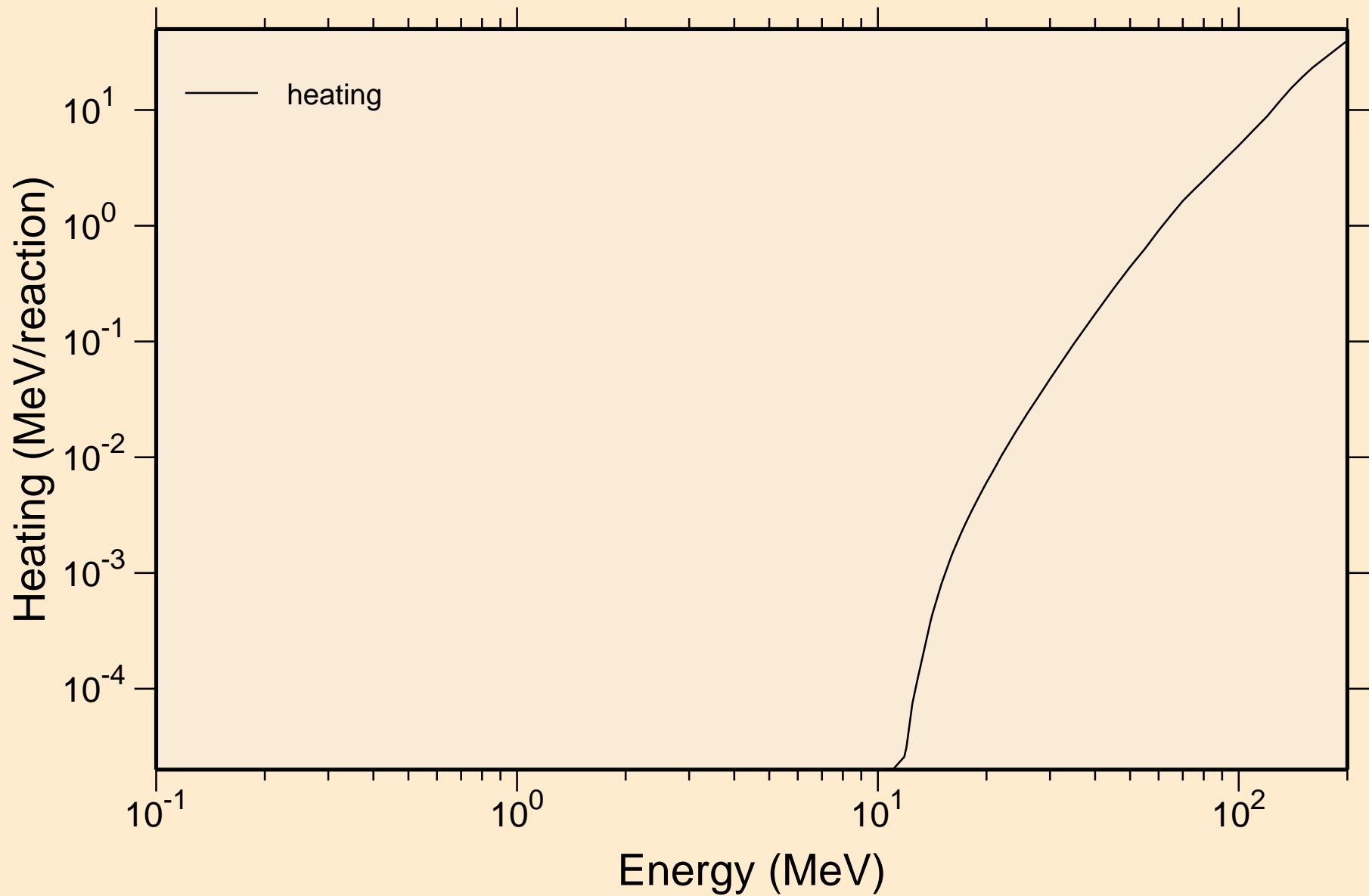

RH106 ALPHA ACER TENDL-2024 LIBRARY; T=0.K

Principal cross sections

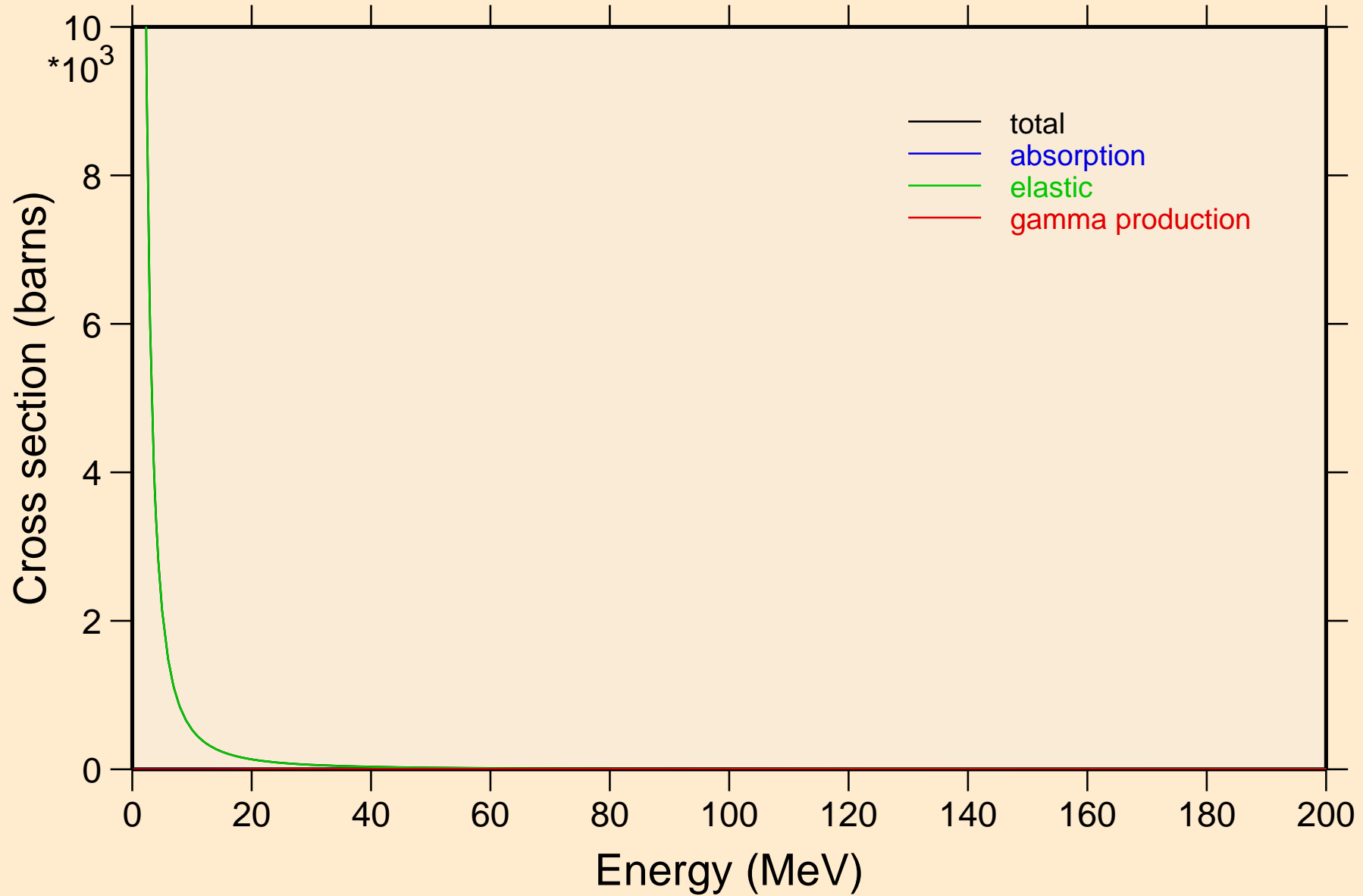

RH106 ALPHA ACER TENDL-2024 LIBRARY; T=0.K

Heating

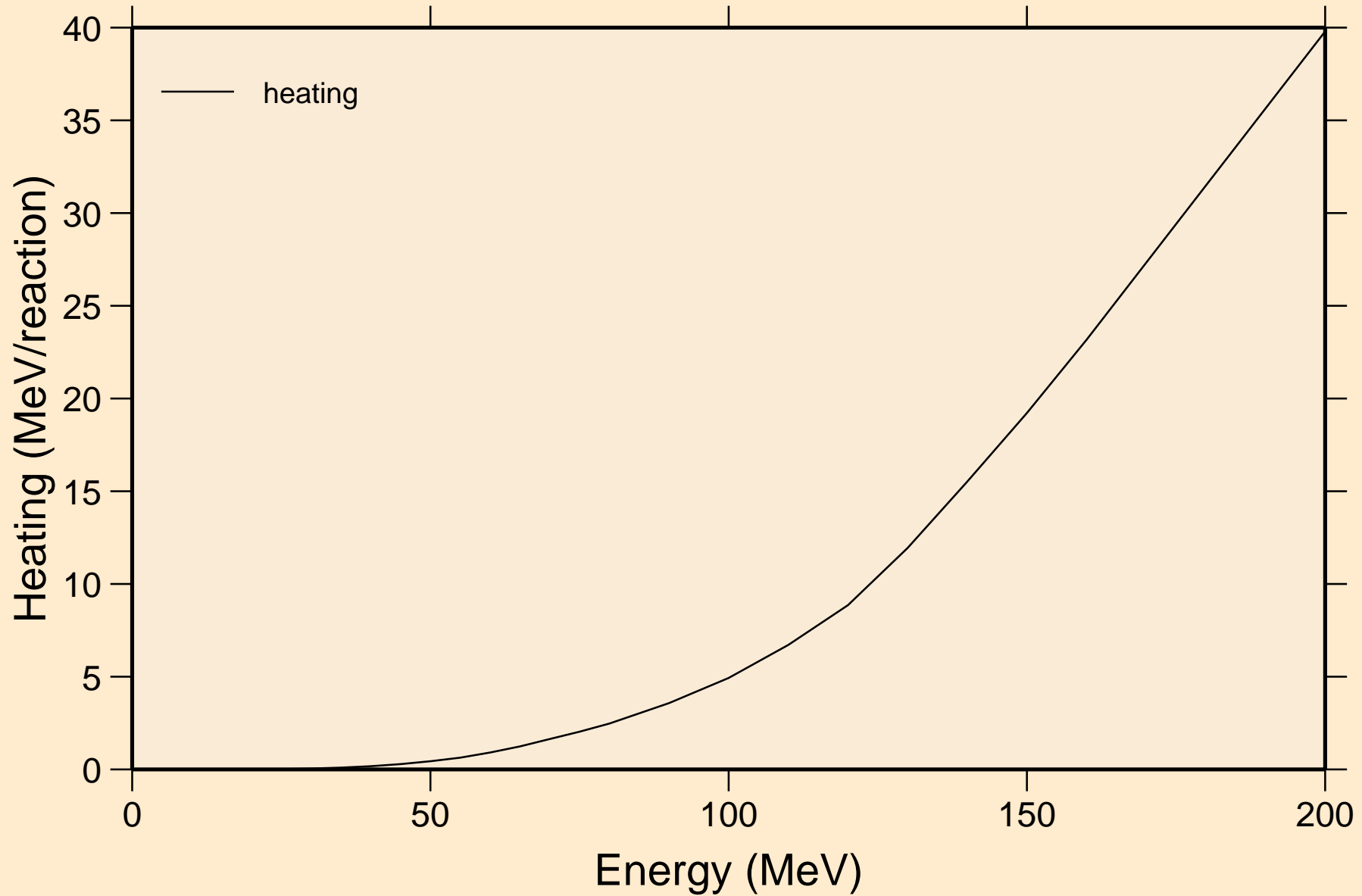

RH106 ALPHA ACER TENDL-2024 LIBRARY; T=0.K
Threshold reactions

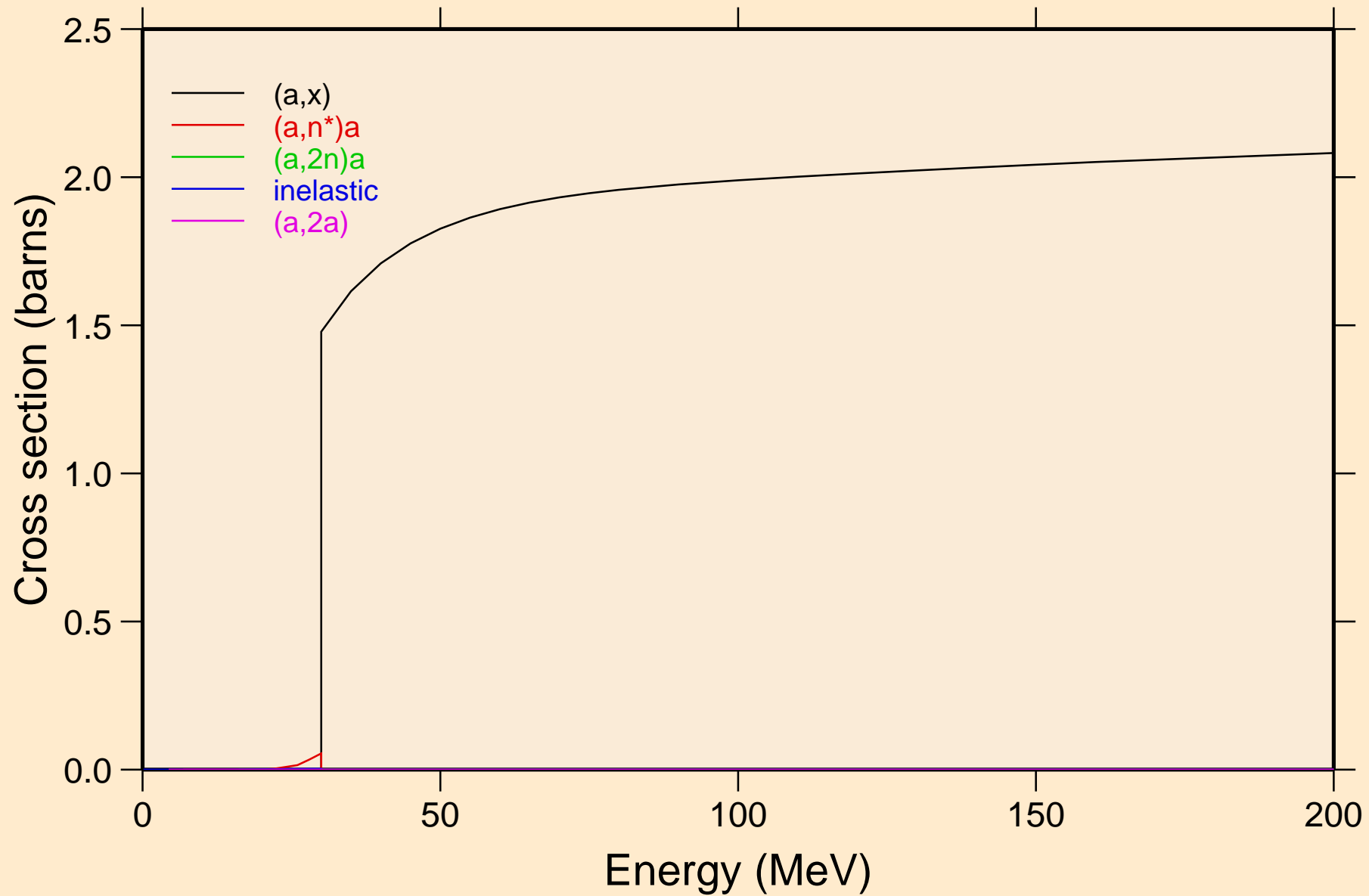

RH106 ALPHA ACER TENDL-2024 LIBRARY; T=0.K
Threshold reactions

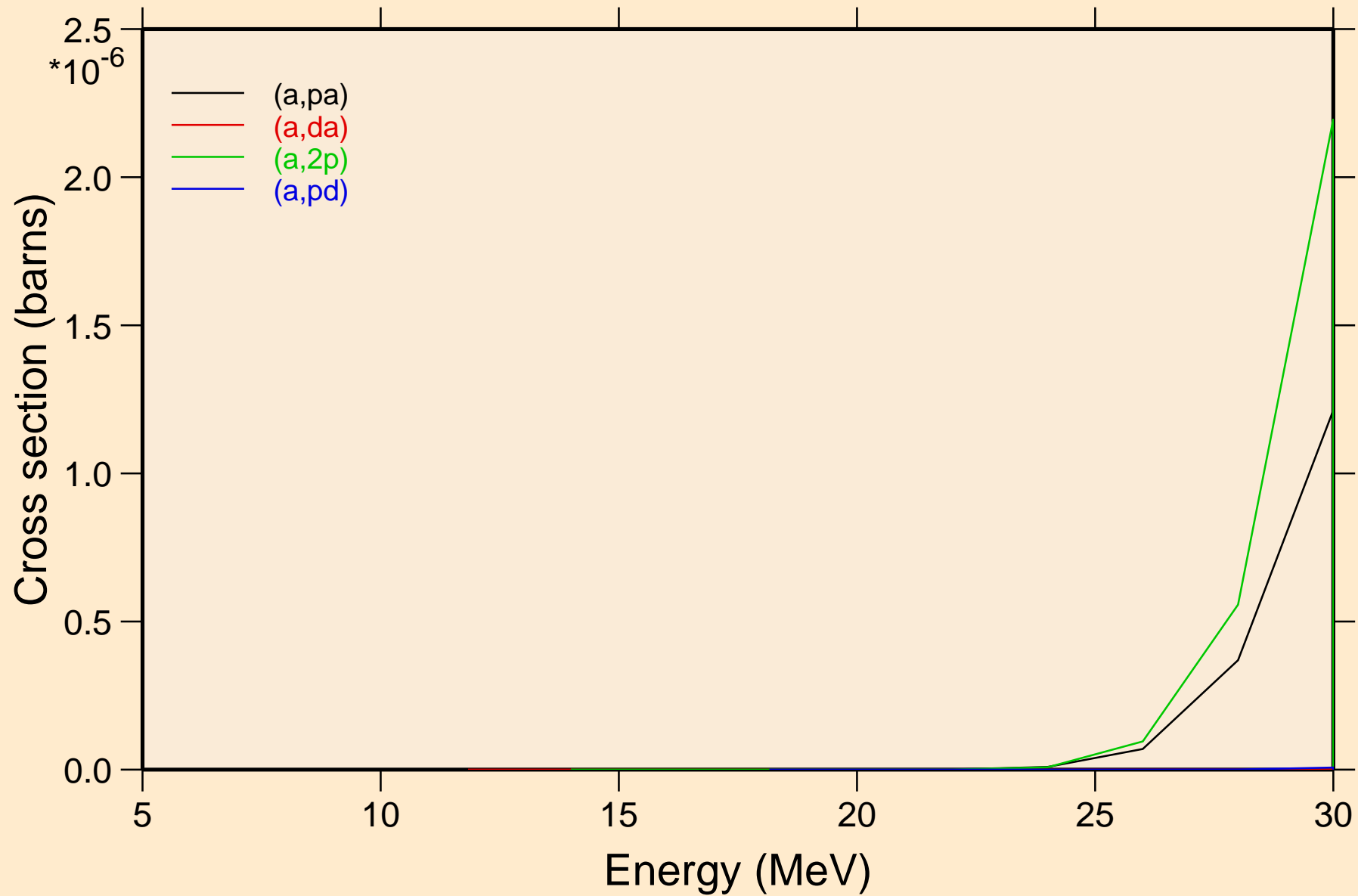

RH106 ALPHA ACER TENDL-2024 LIBRARY; T=0.K
Threshold reactions

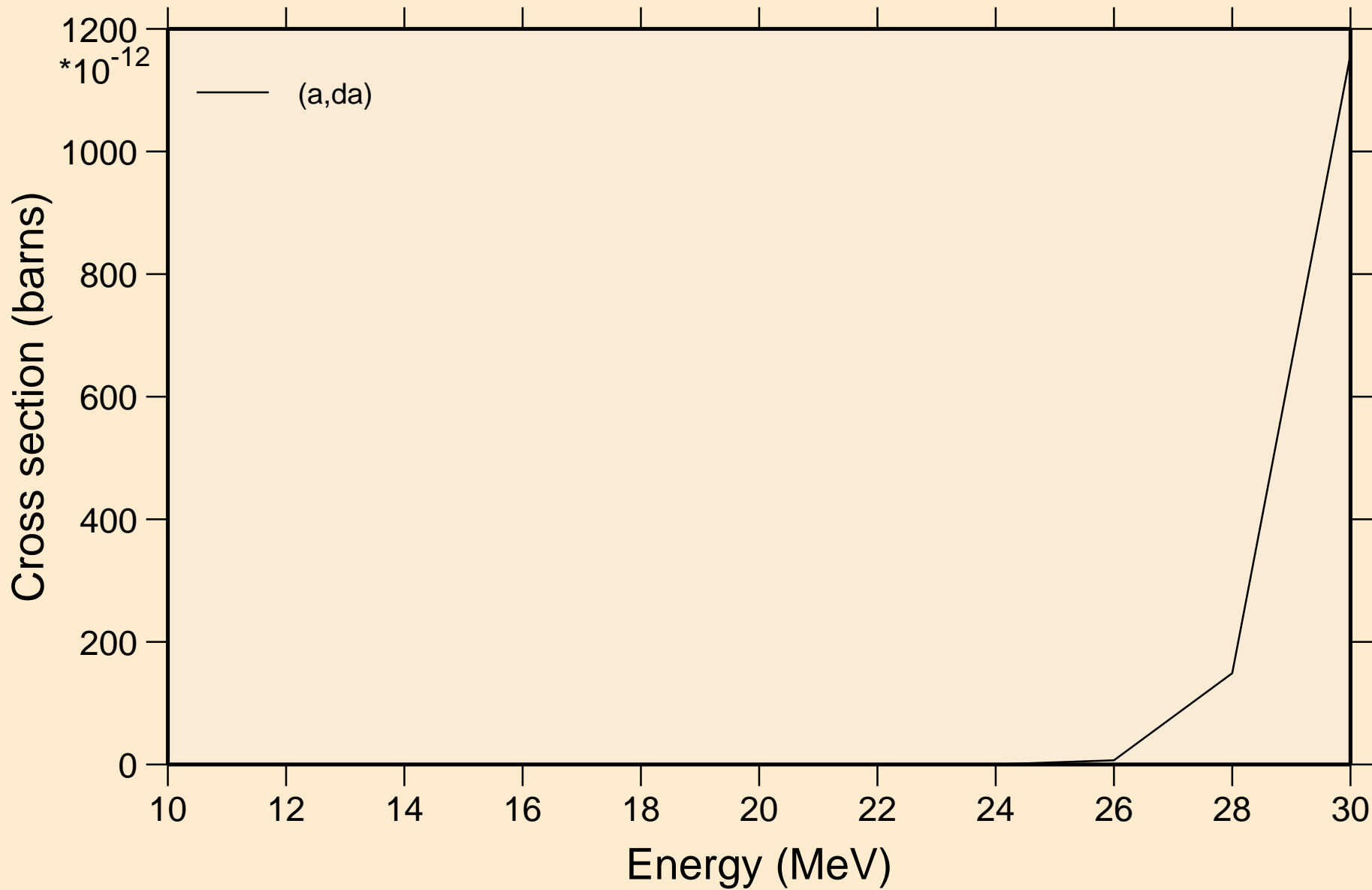

RH106 ALPHA ACER TENDL-2024 LIBRARY; T=0.K
angular distribution for elastic

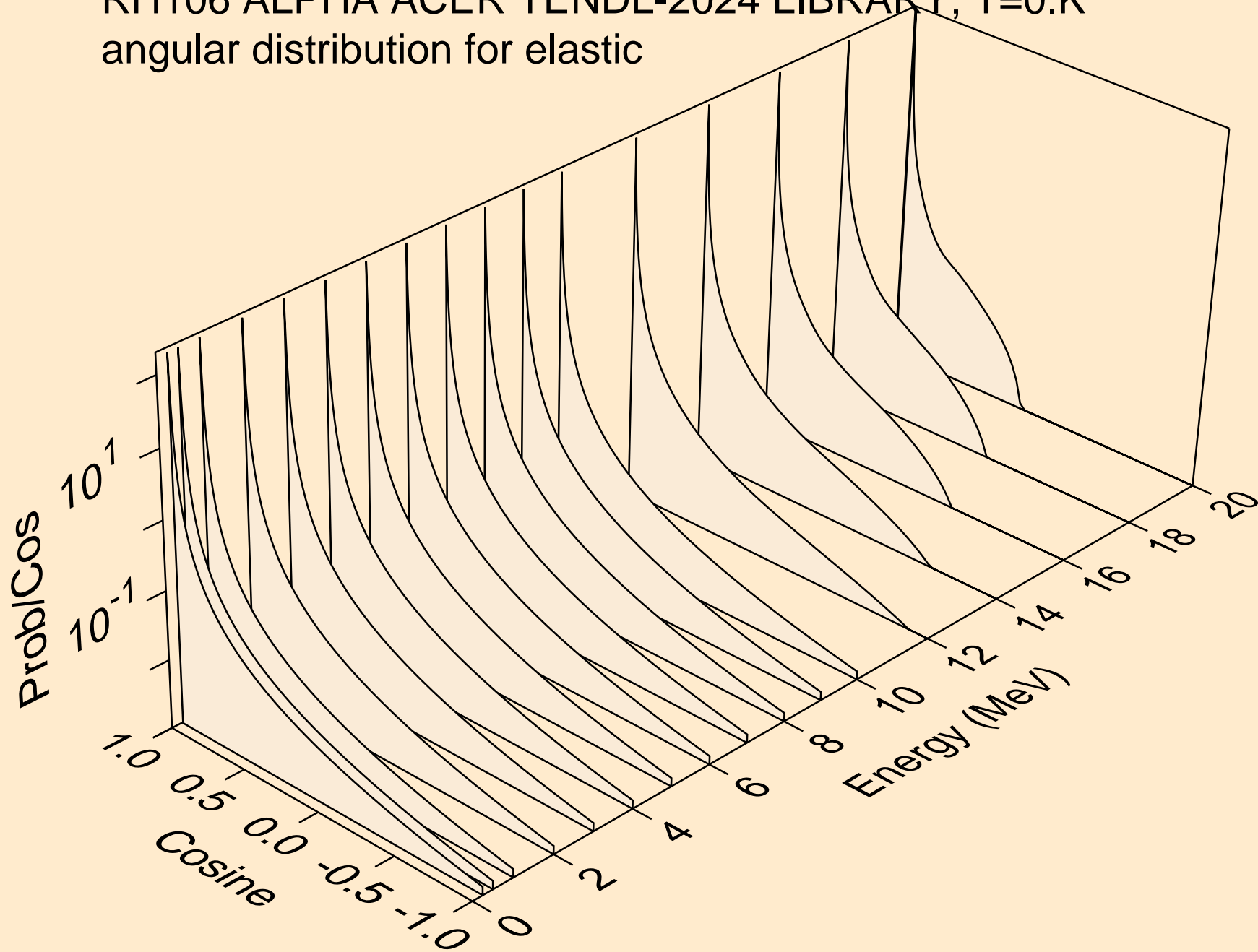

RH106 ALPHA ACER TENDL-2024 LIBRARY; T=0.K
angular distribution for elastic

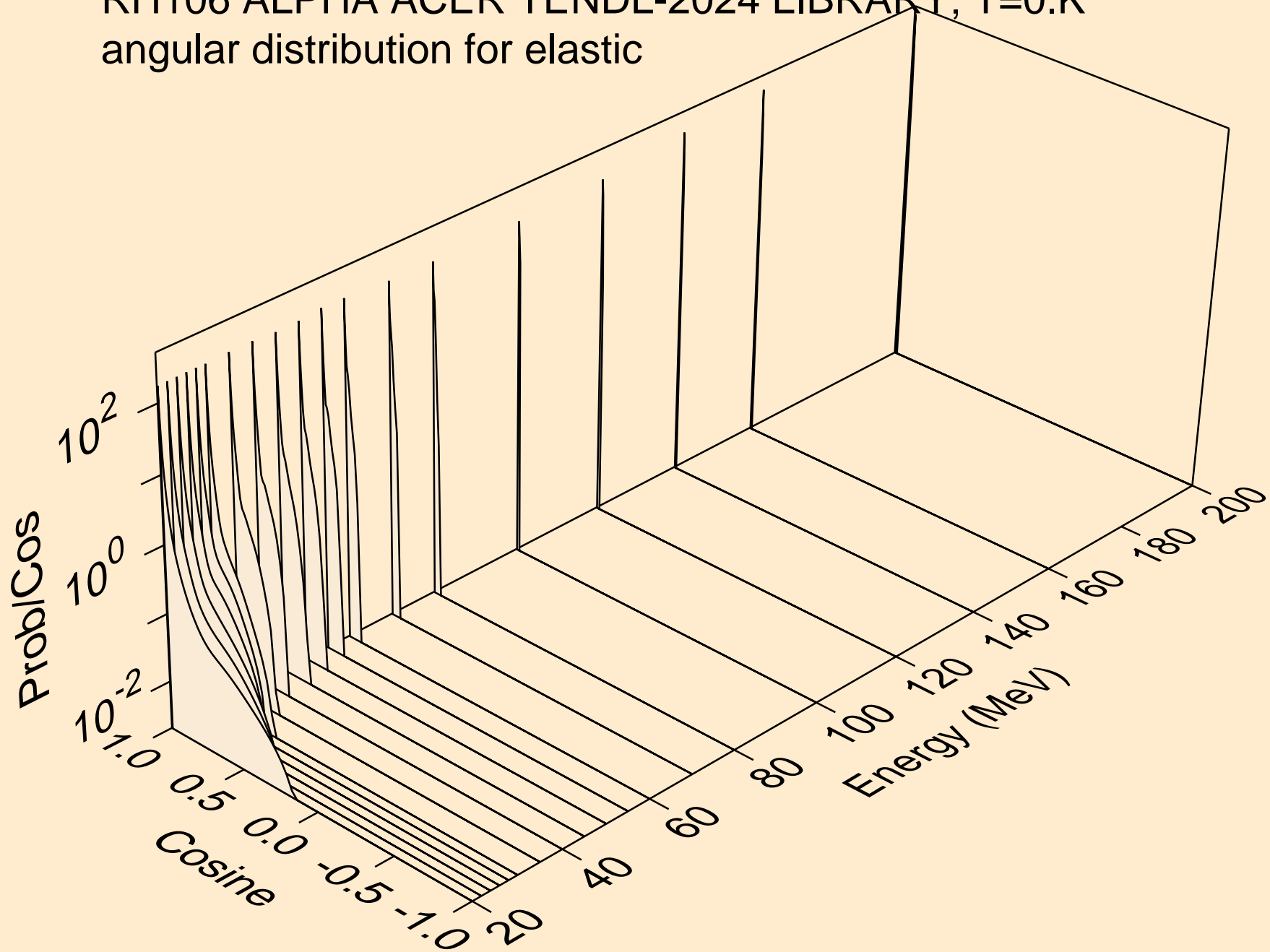

RH106 ALPHA ACER TENDL-2024 LIBRARY; T=0.K
Alpha emission for (a,x)

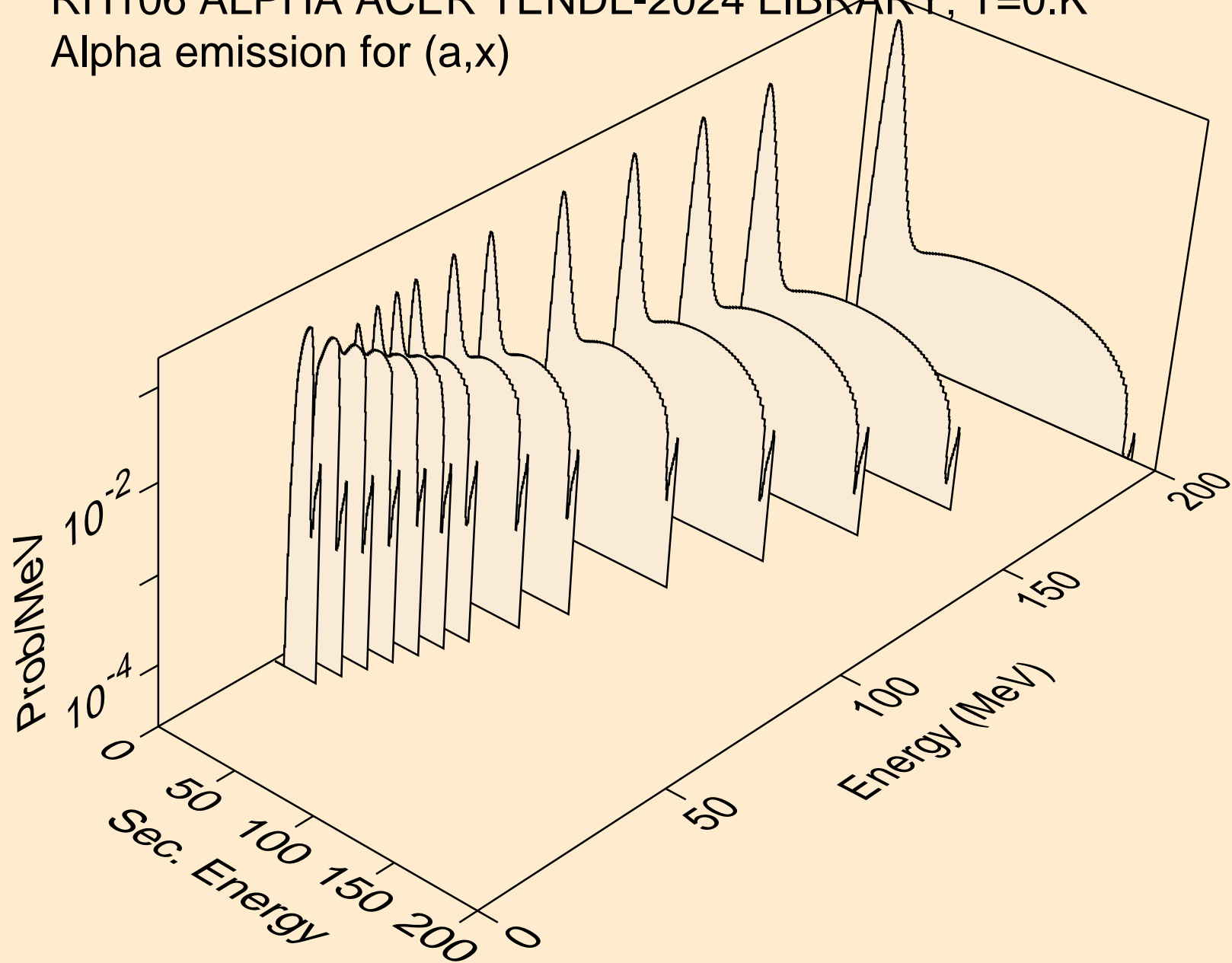

RH106 ALPHA ACER TENDL-2024 LIBRARY; T=0.K
Alpha emission for (a,n*)a

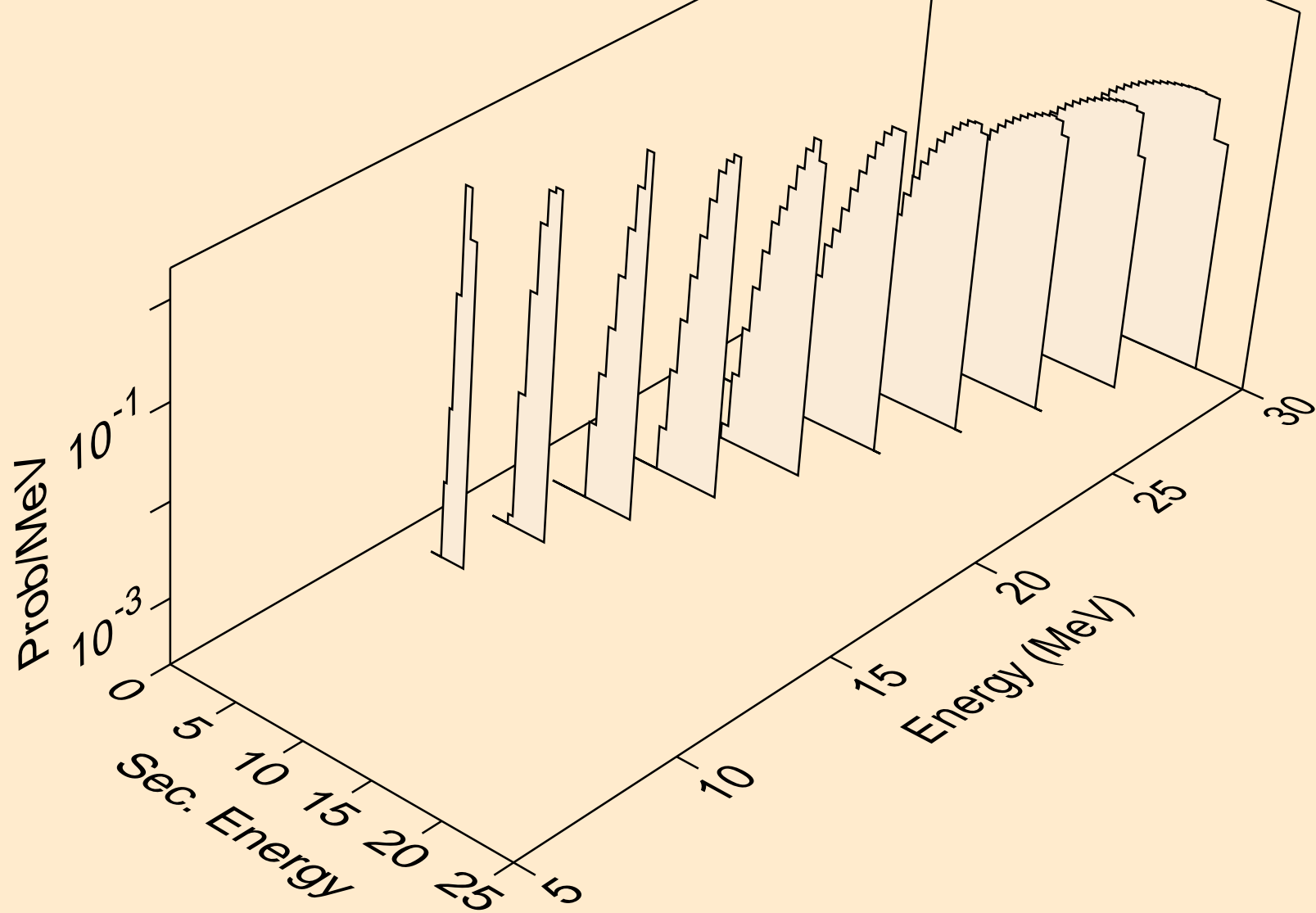

RH106 ALPHA ACER TENDL-2024 LIBRARY; T=0.K
Alpha emission for (a,2n)a

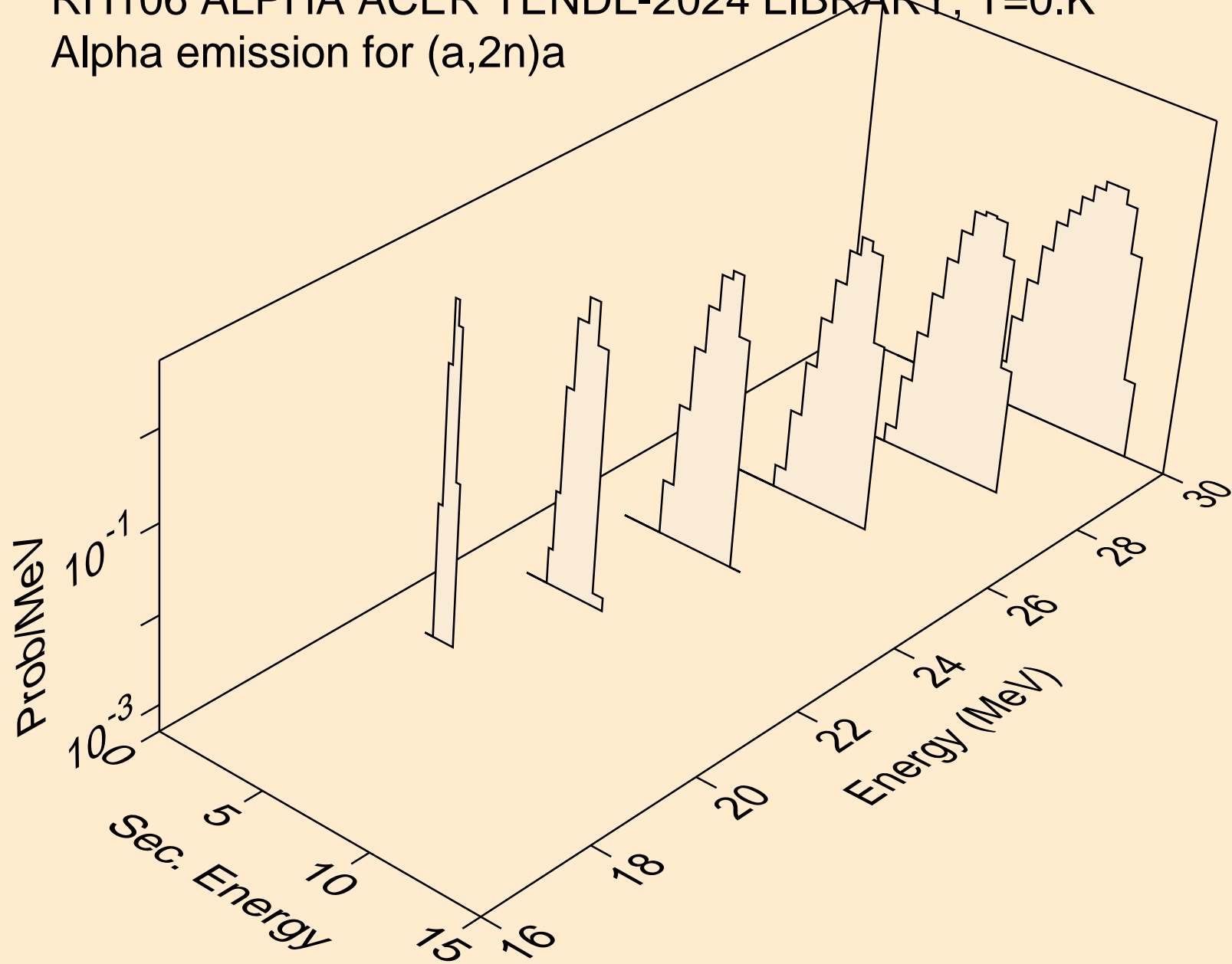

RH106 ALPHA ACER TENDL-2024 LIBRARY; T=0.K
Alpha emission for inelastic

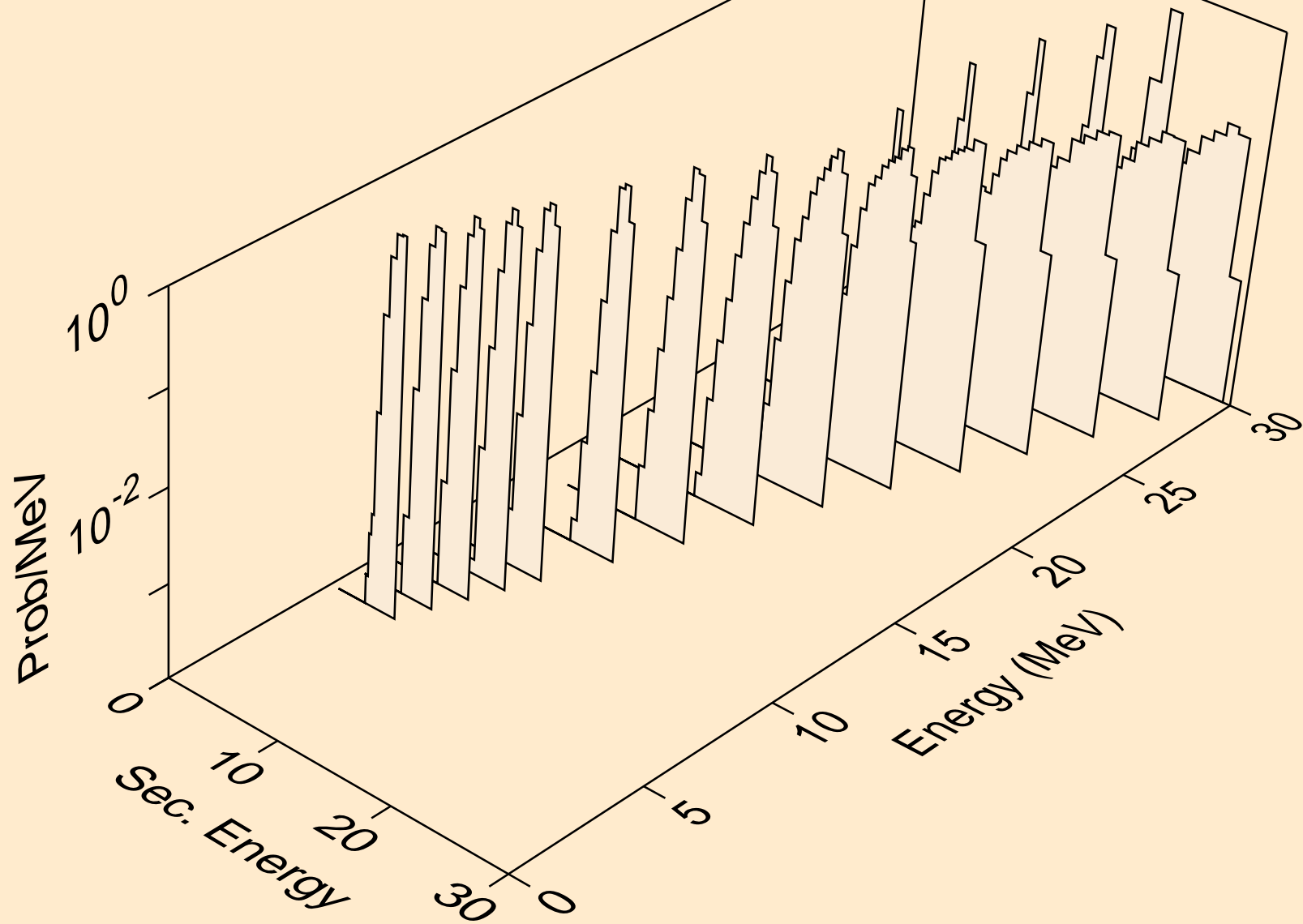

RH106 ALPHA ACER TENDL-2024 LIBRARY; T=0.K
Alpha emission for (a,2a)

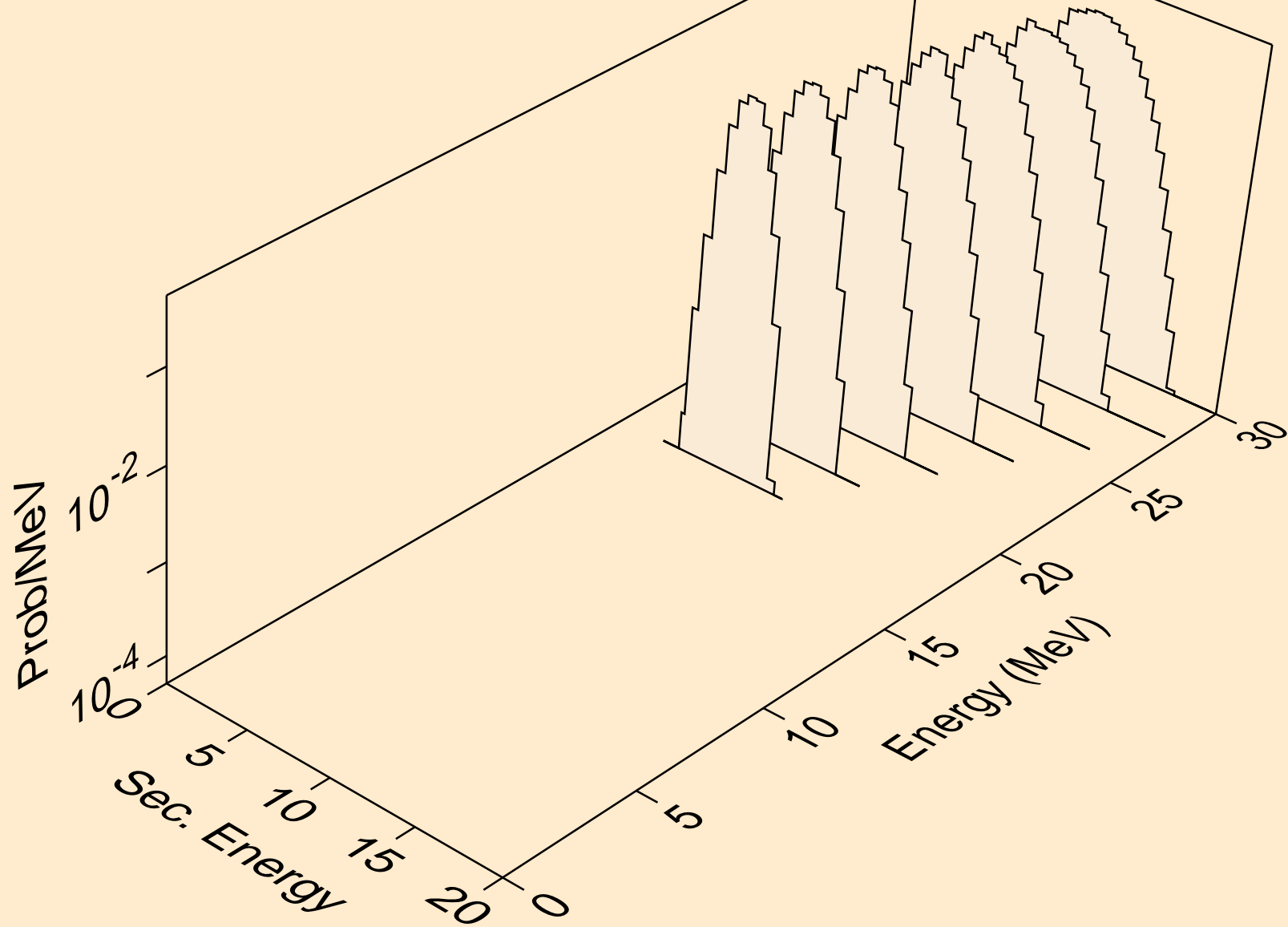

RH106 ALPHA ACER TENDL-2024 LIBRARY; T=0.K
Alpha emission for (a,pa)

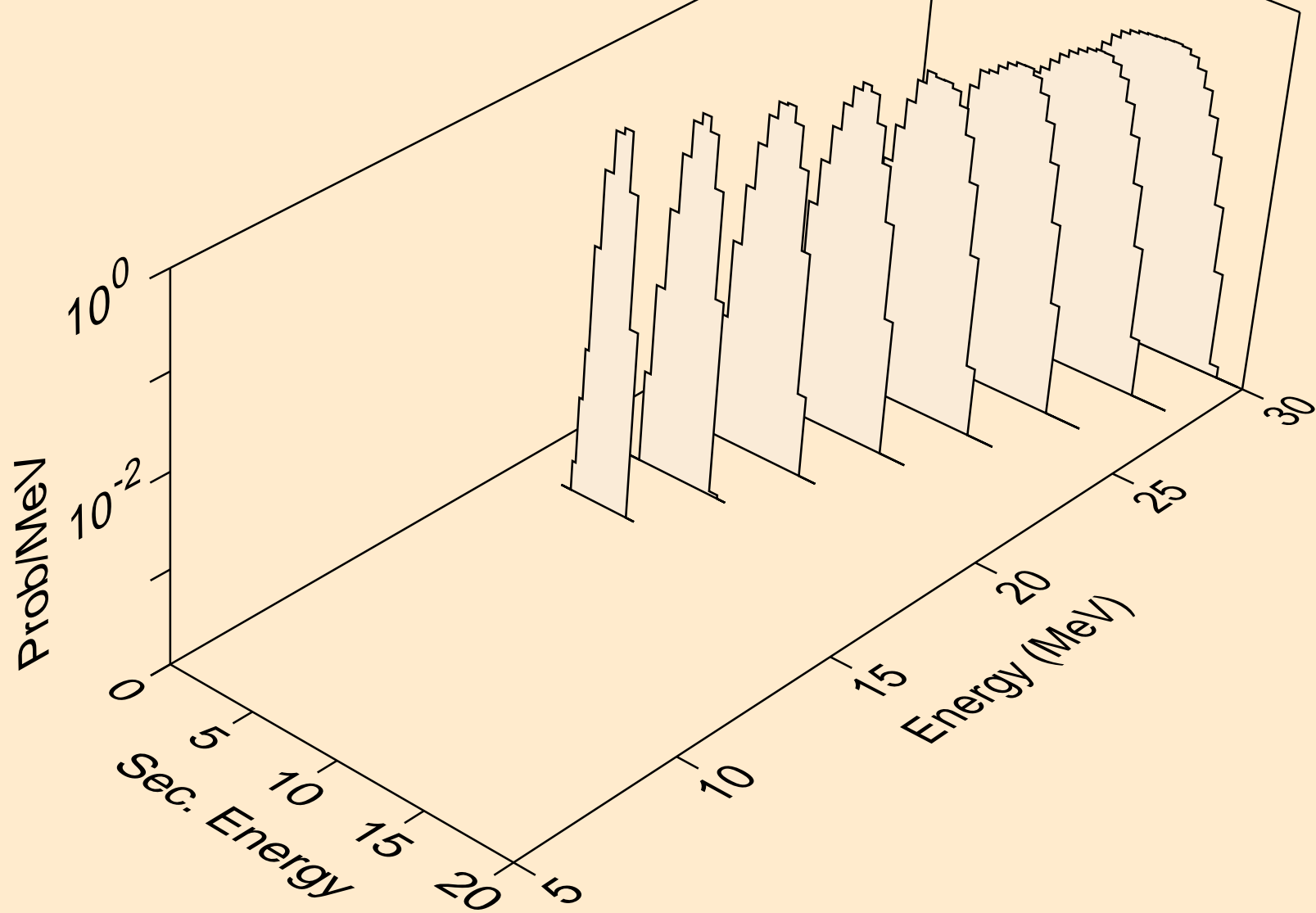

RH106 ALPHA ACER TENDL-2024 LIBRARY; T=0.K
Alpha emission for (a,da)

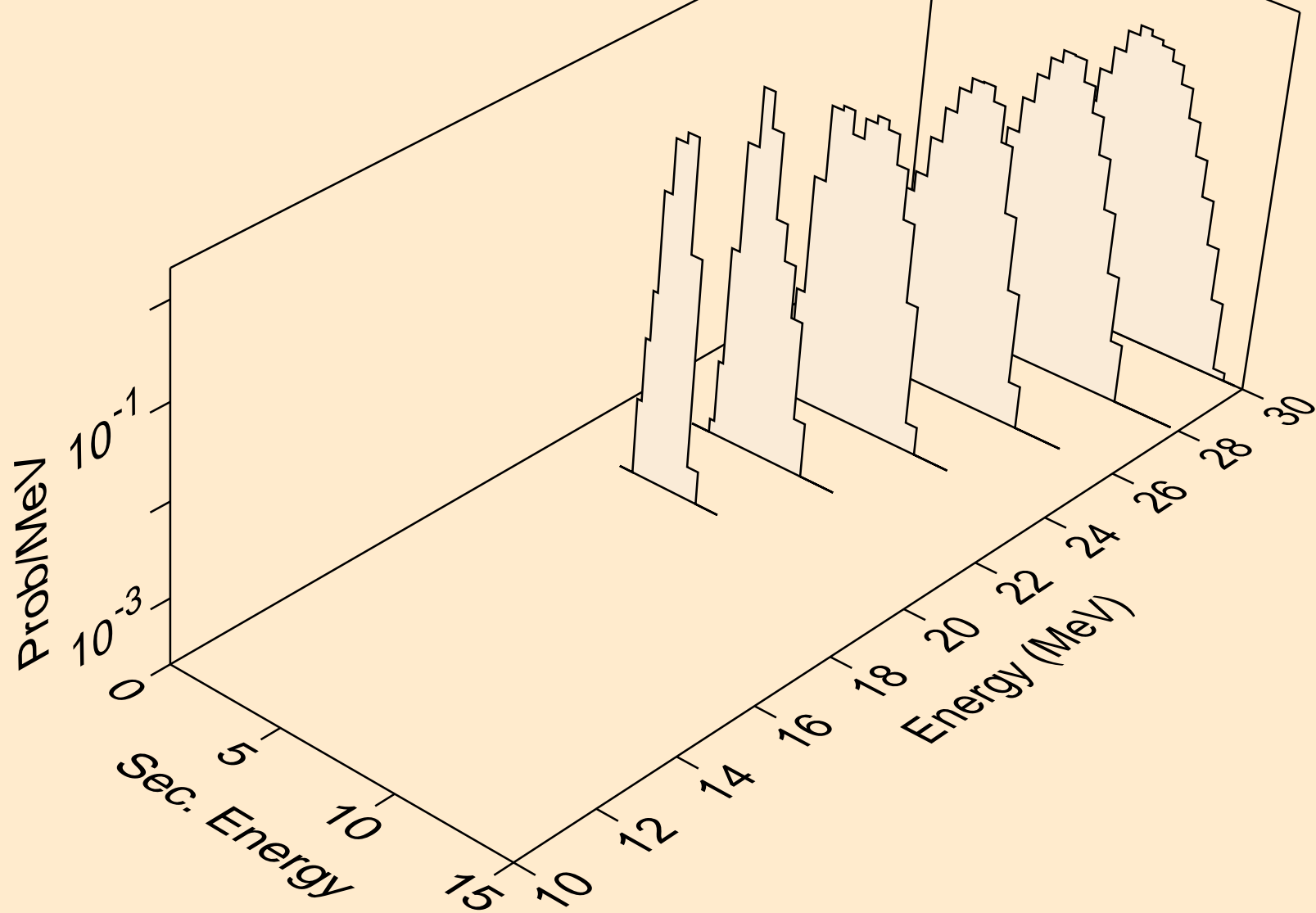

RH106 ALPHA ACER TENDL-2024 LIBRARY; T=0.K
Photon emission for (z,n)

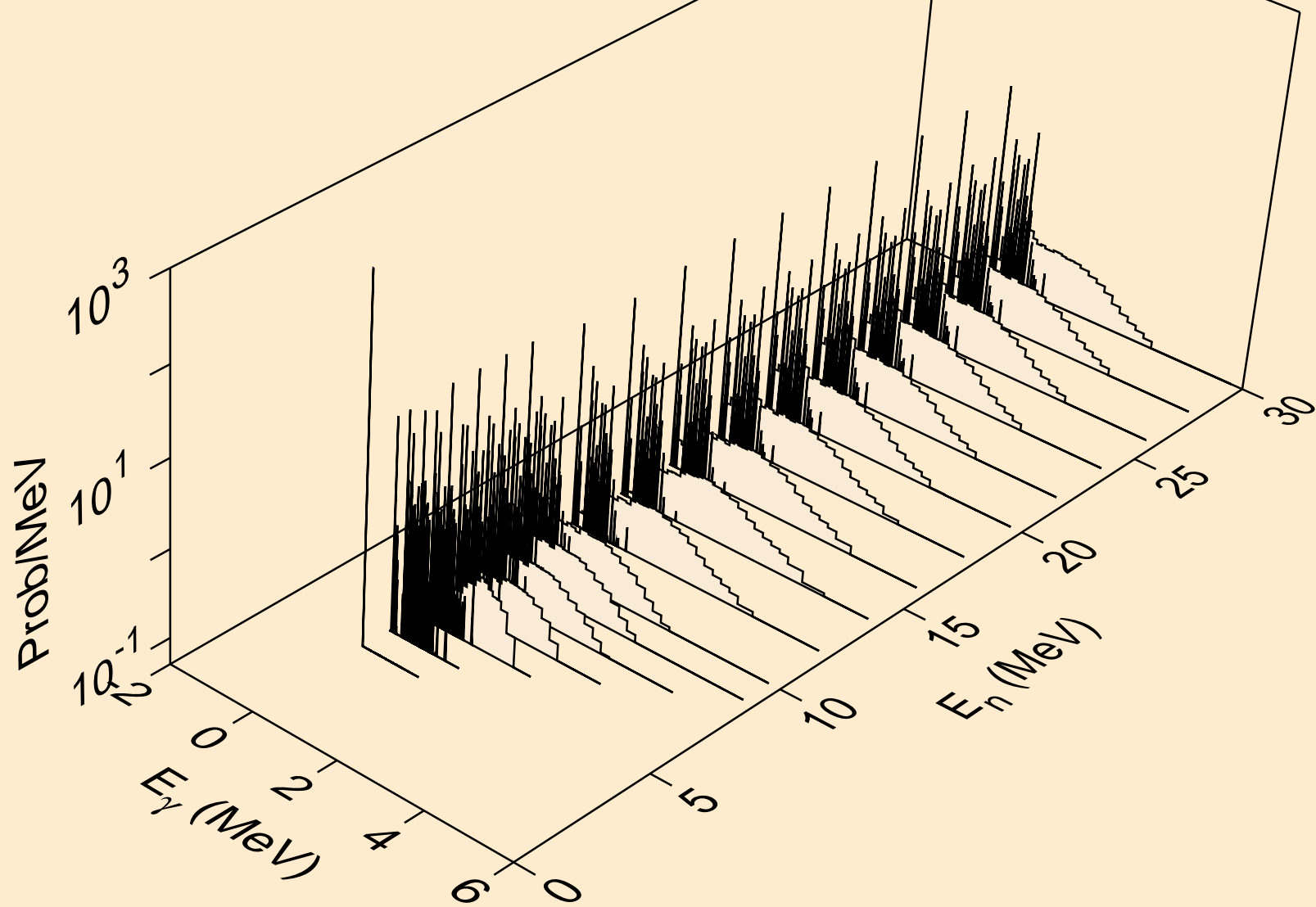

RH106 ALPHA ACER TENDL-2024 LIBRARY; T=0.K
Photon emission for (z,x)

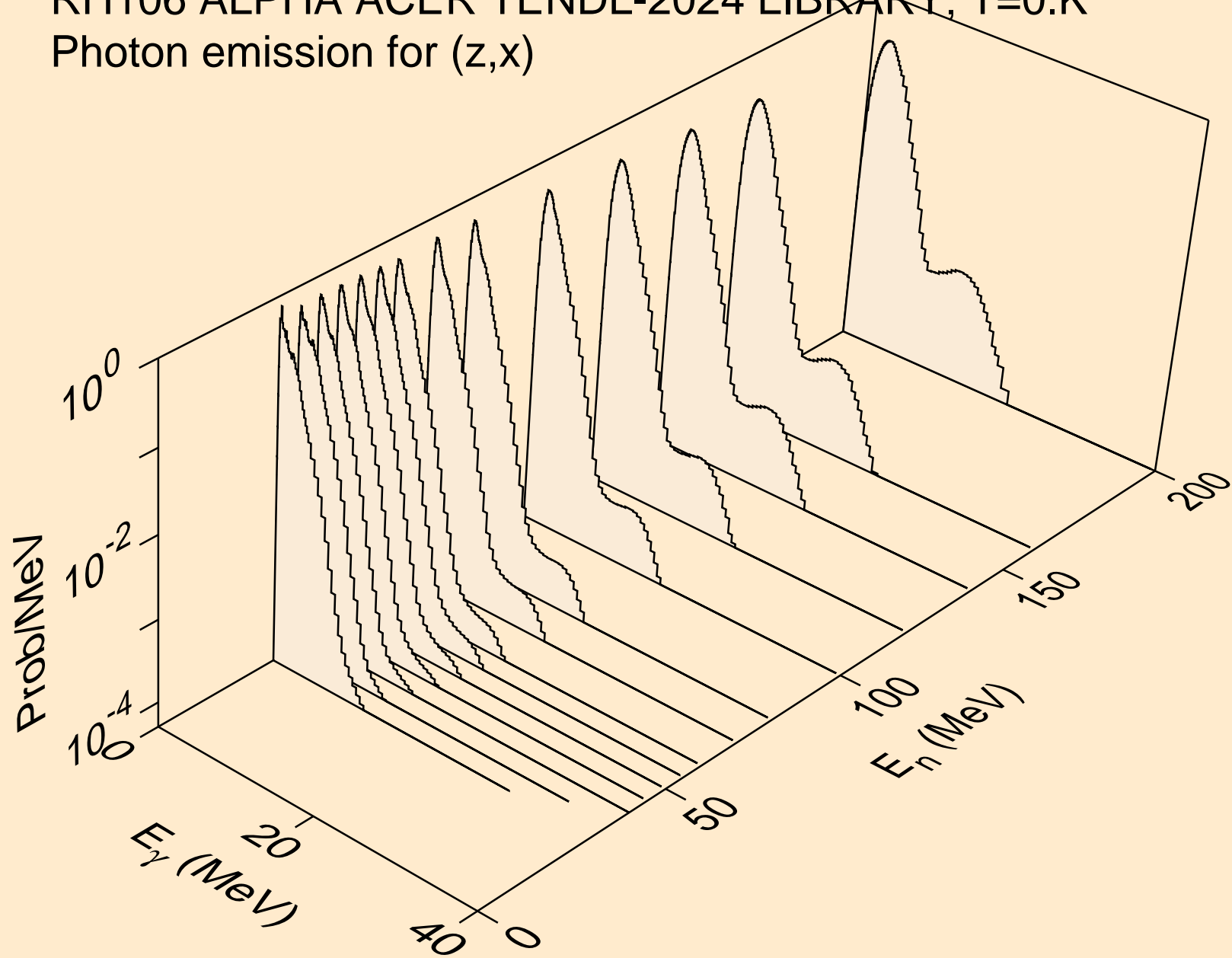

RH106 ALPHA ACER TENDL-2024 LIBRARY; T=0.K
Photon emission for (n,2nd)

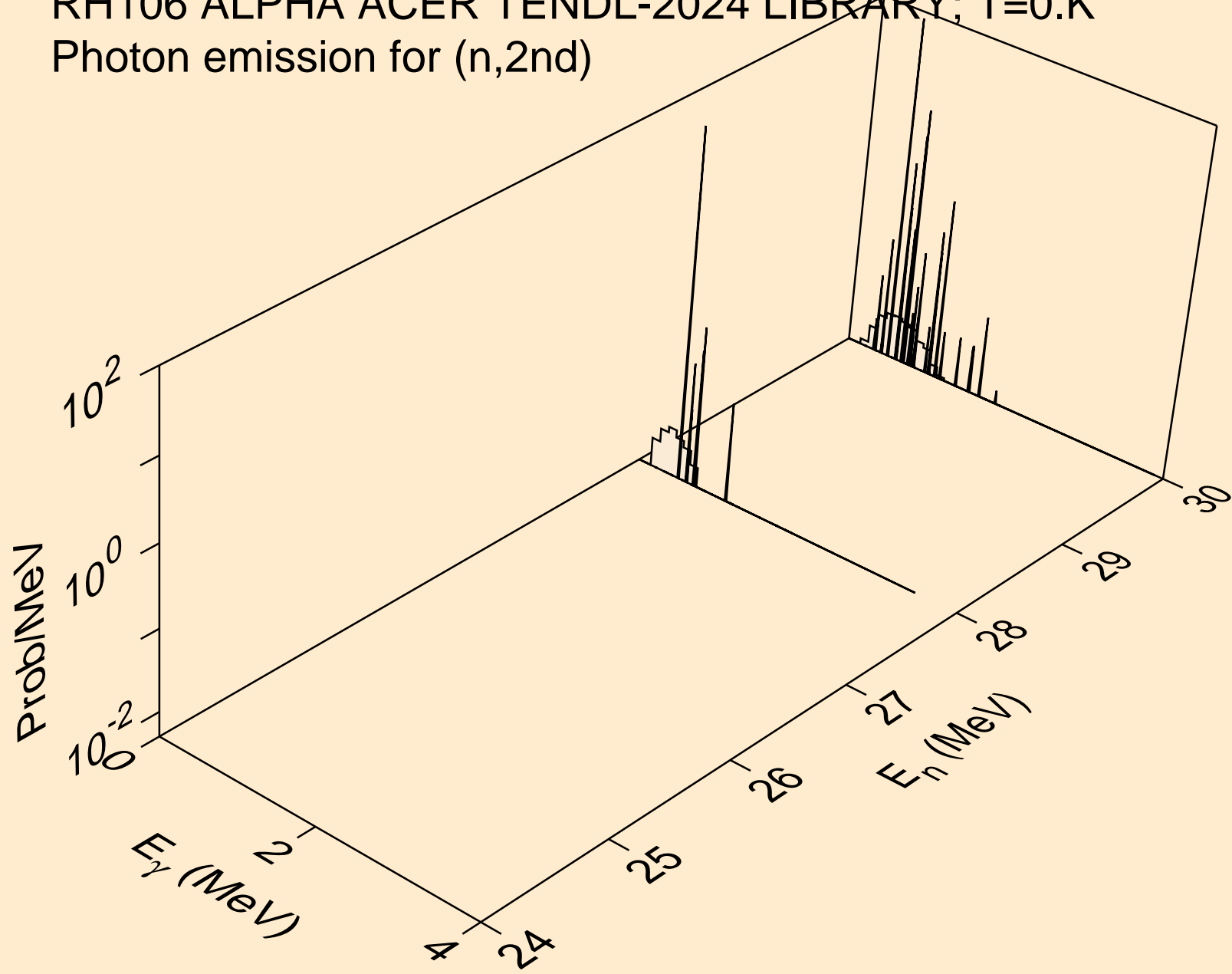

RH106 ALPHA ACER TENDL-2024 LIBRARY; T=0.K
Photon emission for (n,2n)

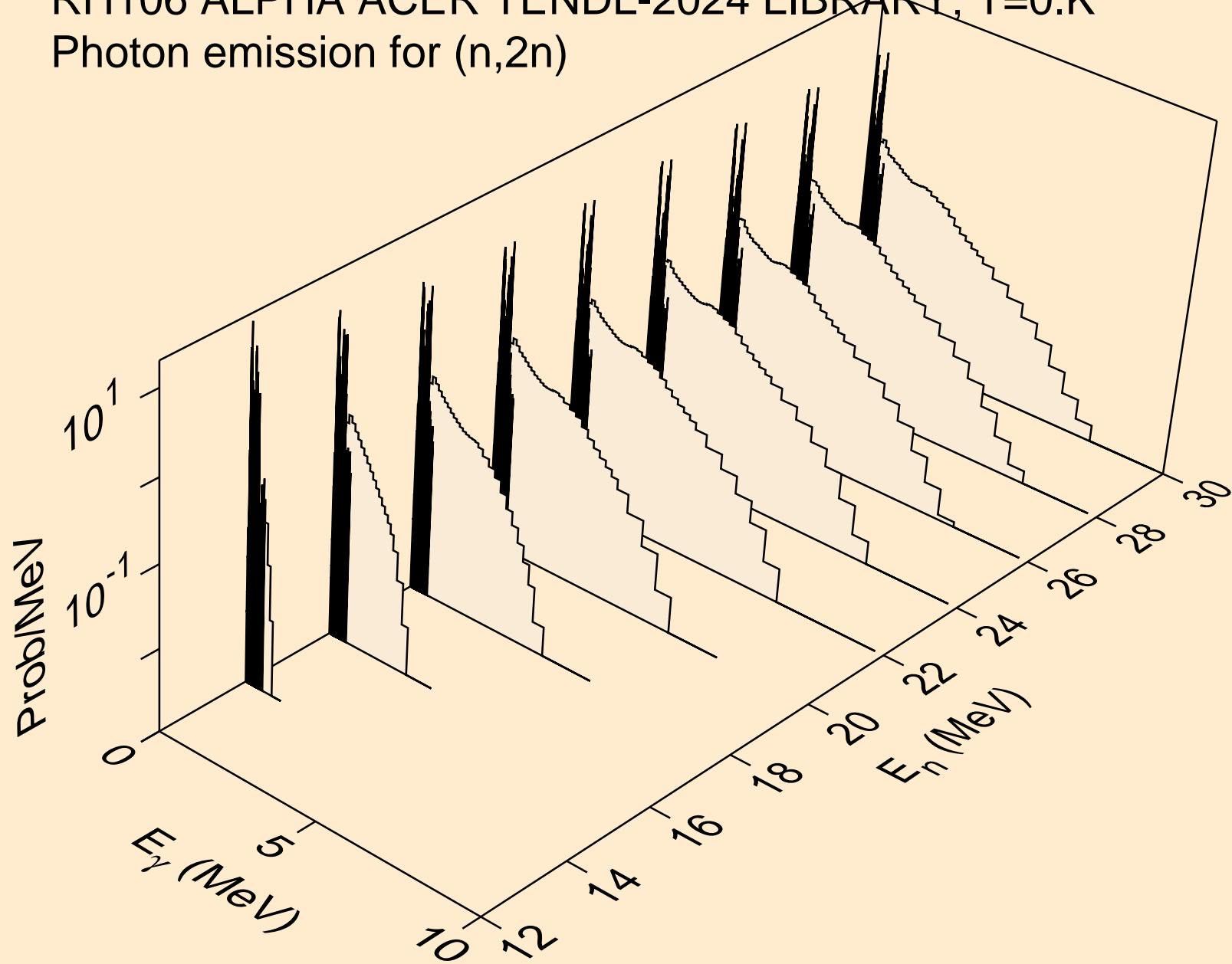

RH106 ALPHA ACER TENDL-2024 LIBRARY; T=0.K
Photon emission for (n,3n)

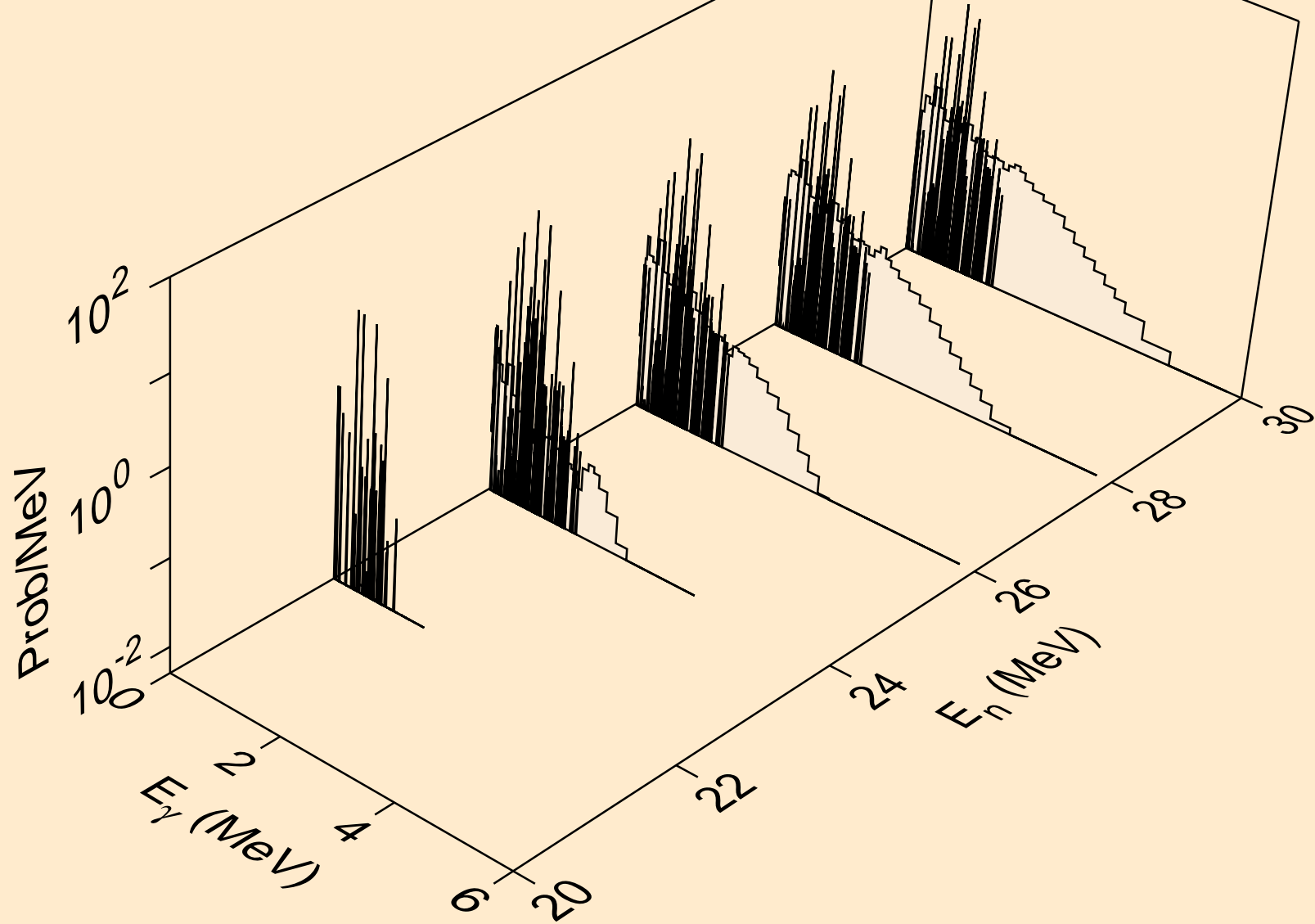

RH106 ALPHA ACER TENDL-2024 LIBRARY; T=0.K
Photon emission for (n,n*)a

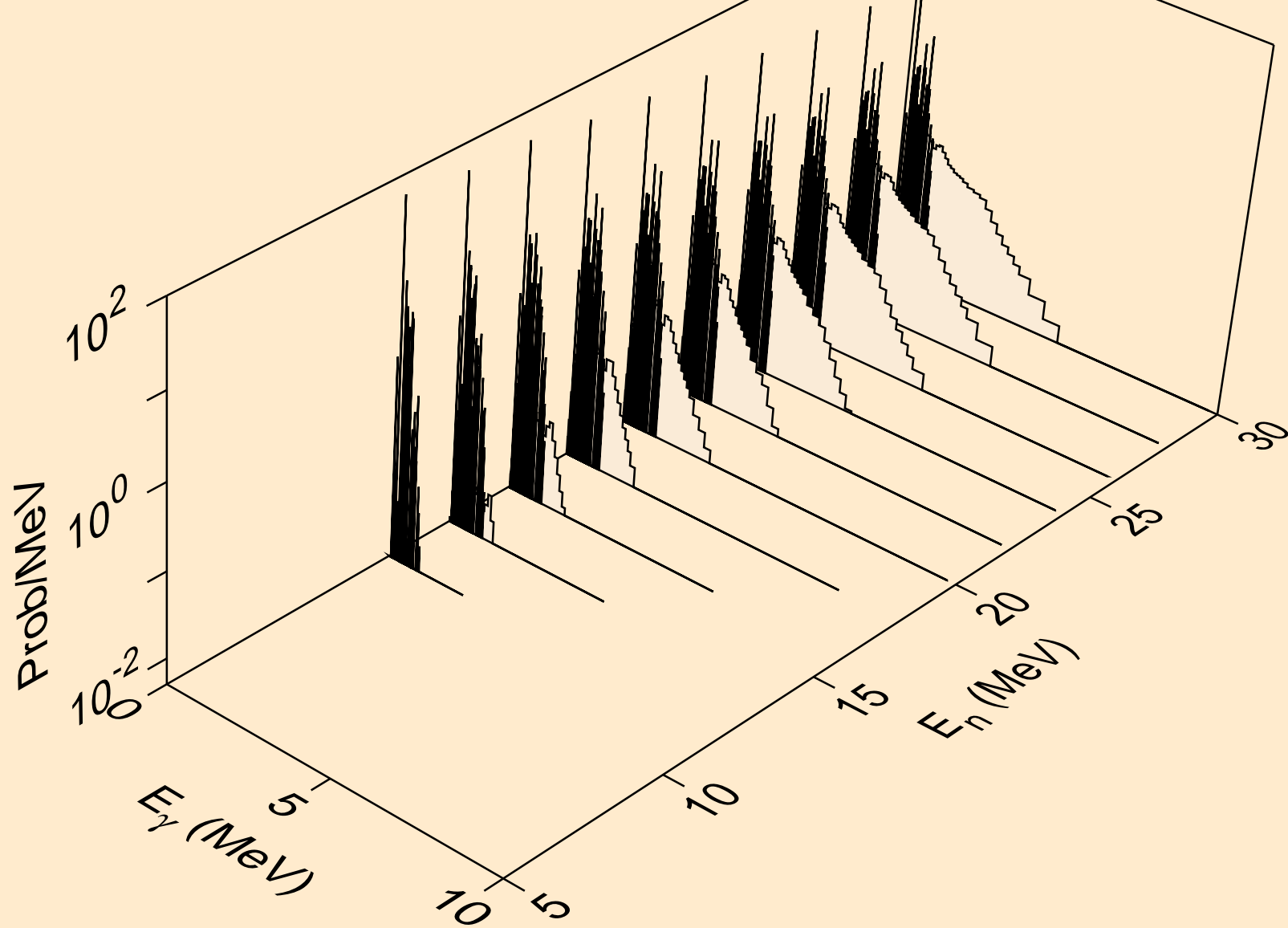

RH106 ALPHA ACER TENDL-2024 LIBRARY; T=0.K
Photon emission for (n,2n)a

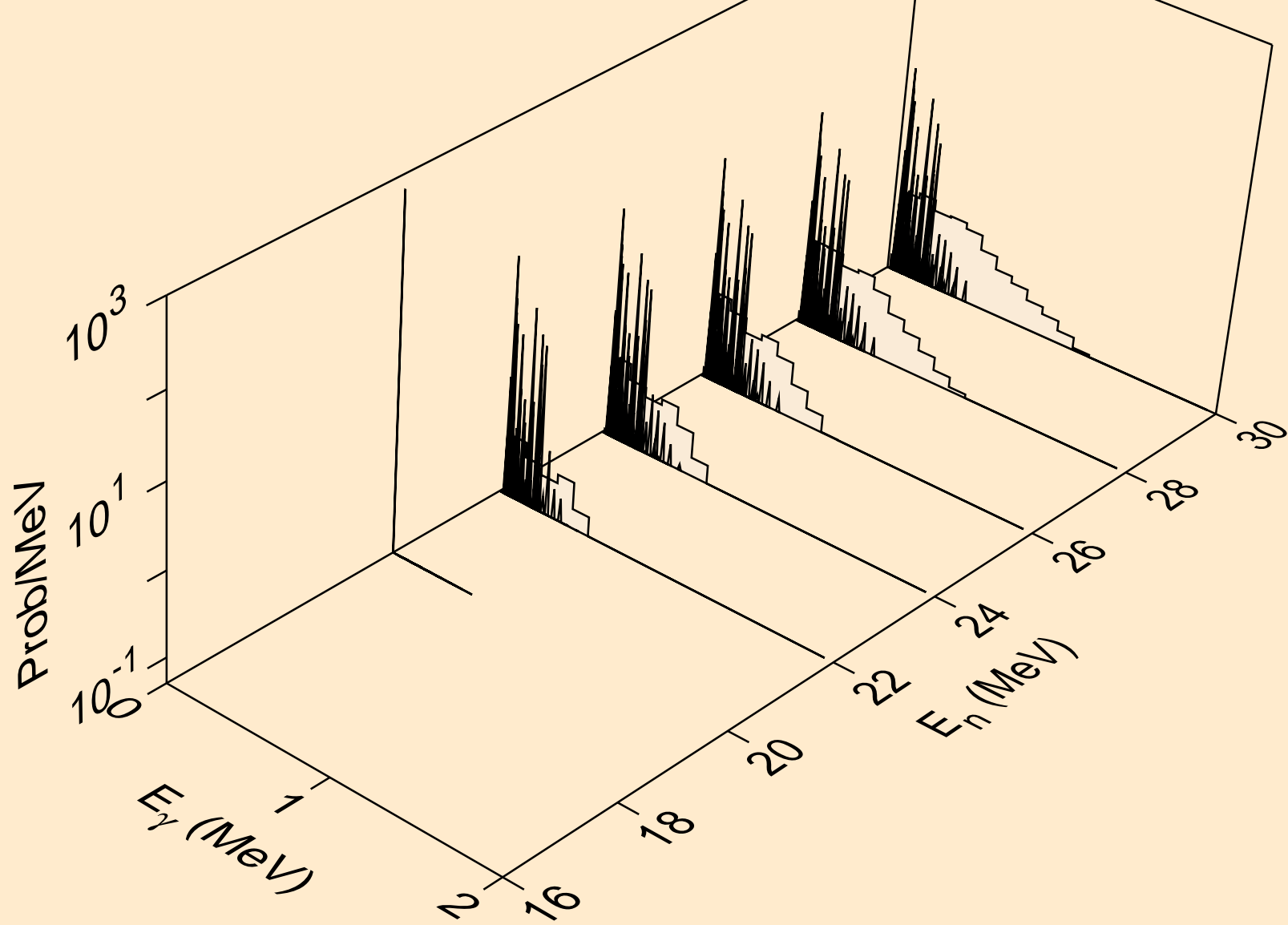

RH106 ALPHA ACER TENDL-2024 LIBRARY; T=0.K
Photon emission for (n,n*)p

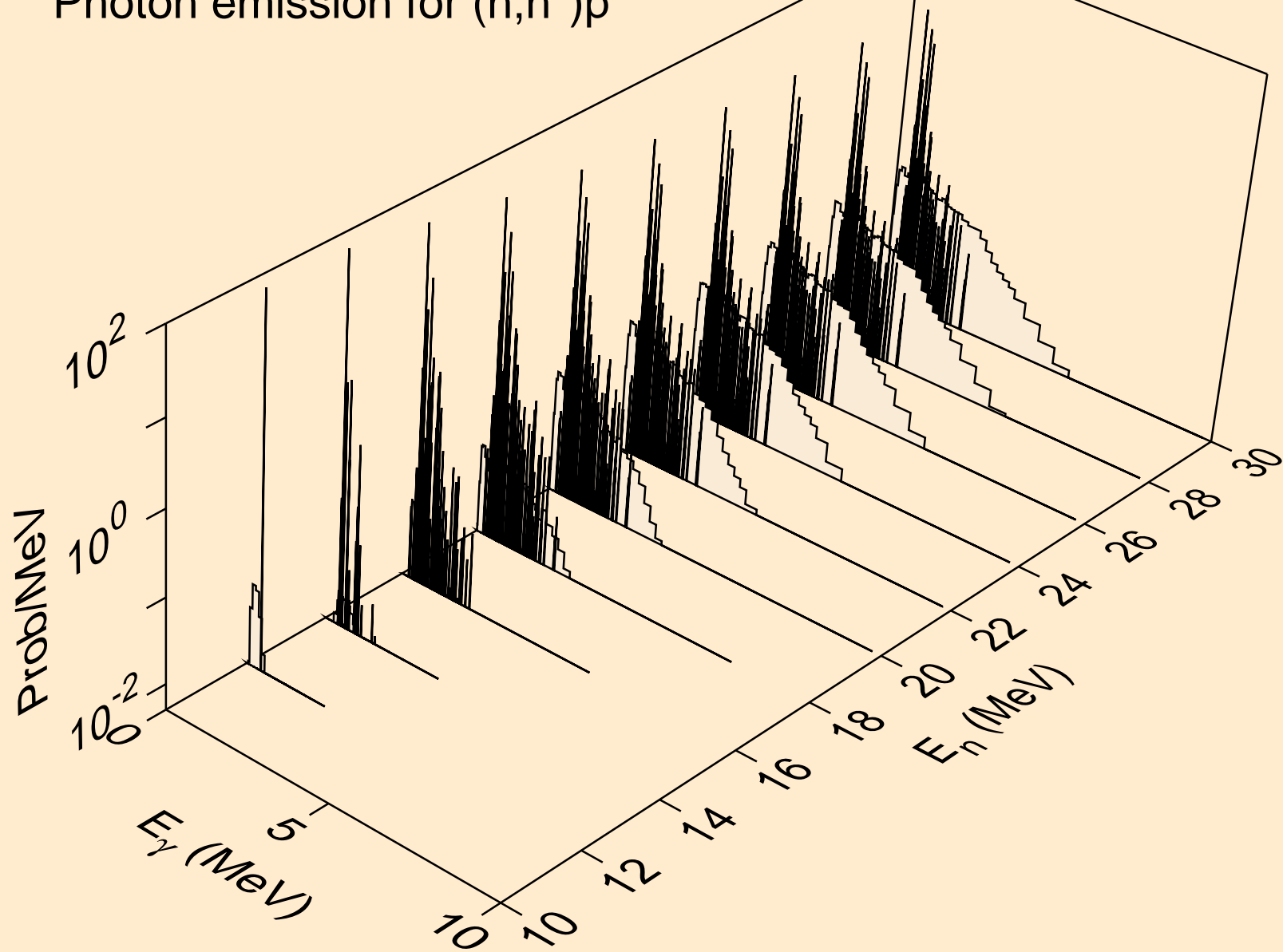

RH106 ALPHA ACER TENDL-2024 LIBRARY; T=0.K
Photon emission for (n,n*)d

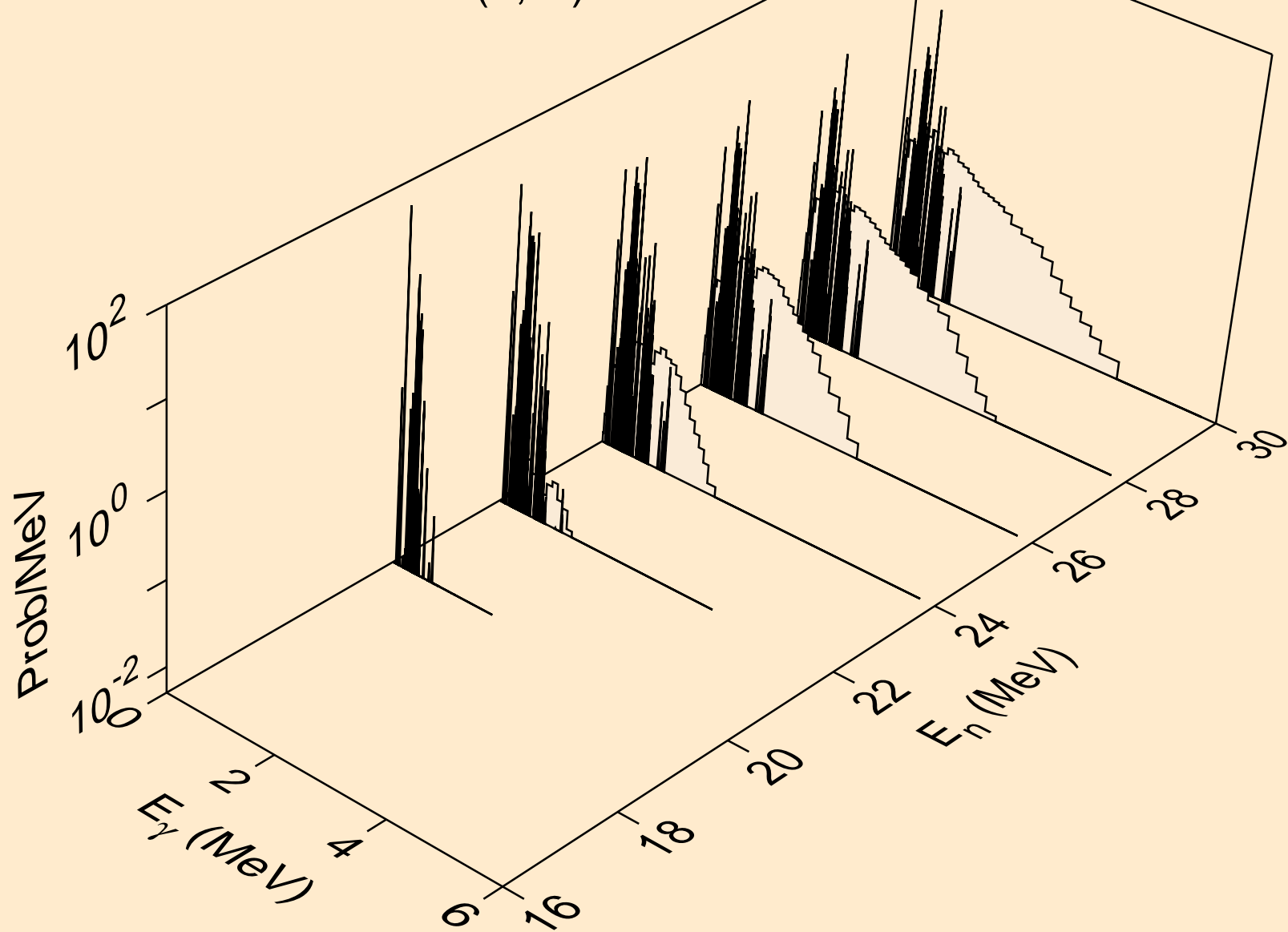

RH106 ALPHA ACER TENDL-2024 LIBRARY; T=0.K
Photon emission for (n,n*)t

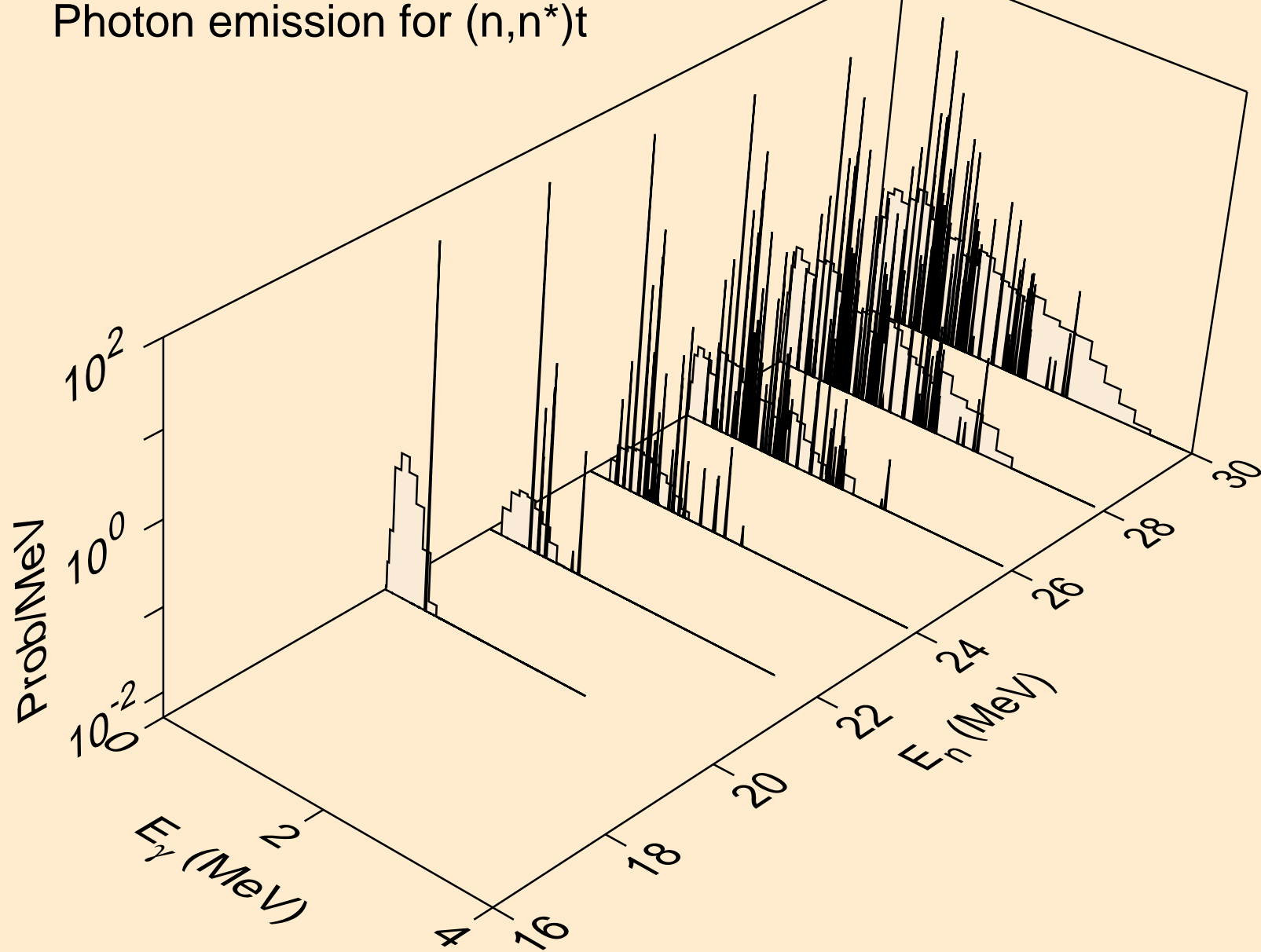

RH106 ALPHA ACER TENDL-2024 LIBRARY; T=0.K
Photon emission for (n,n*)he3

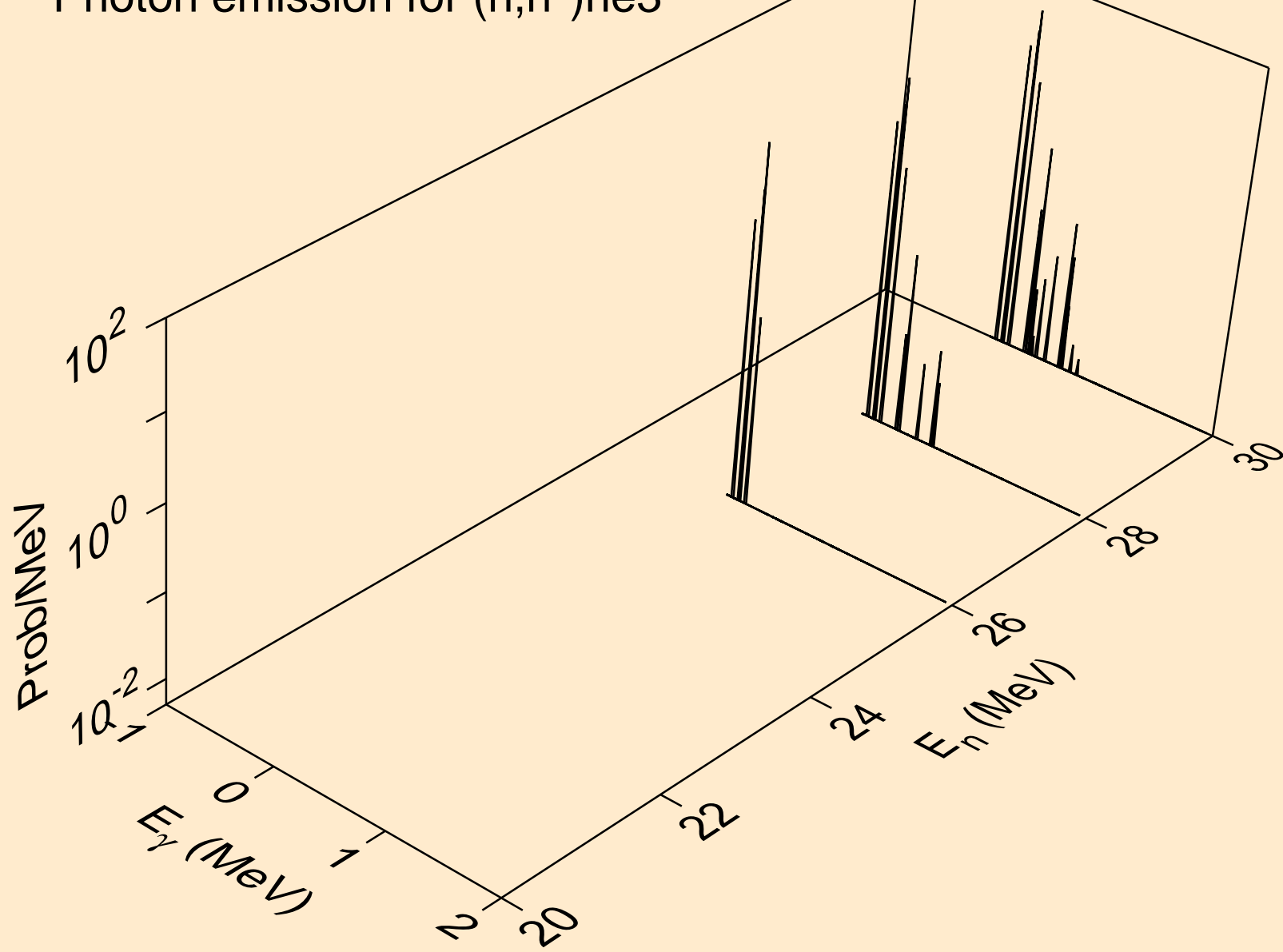

RH106 ALPHA ACER TENDL-2024 LIBRARY; T=0.K
Photon emission for (n,2np)

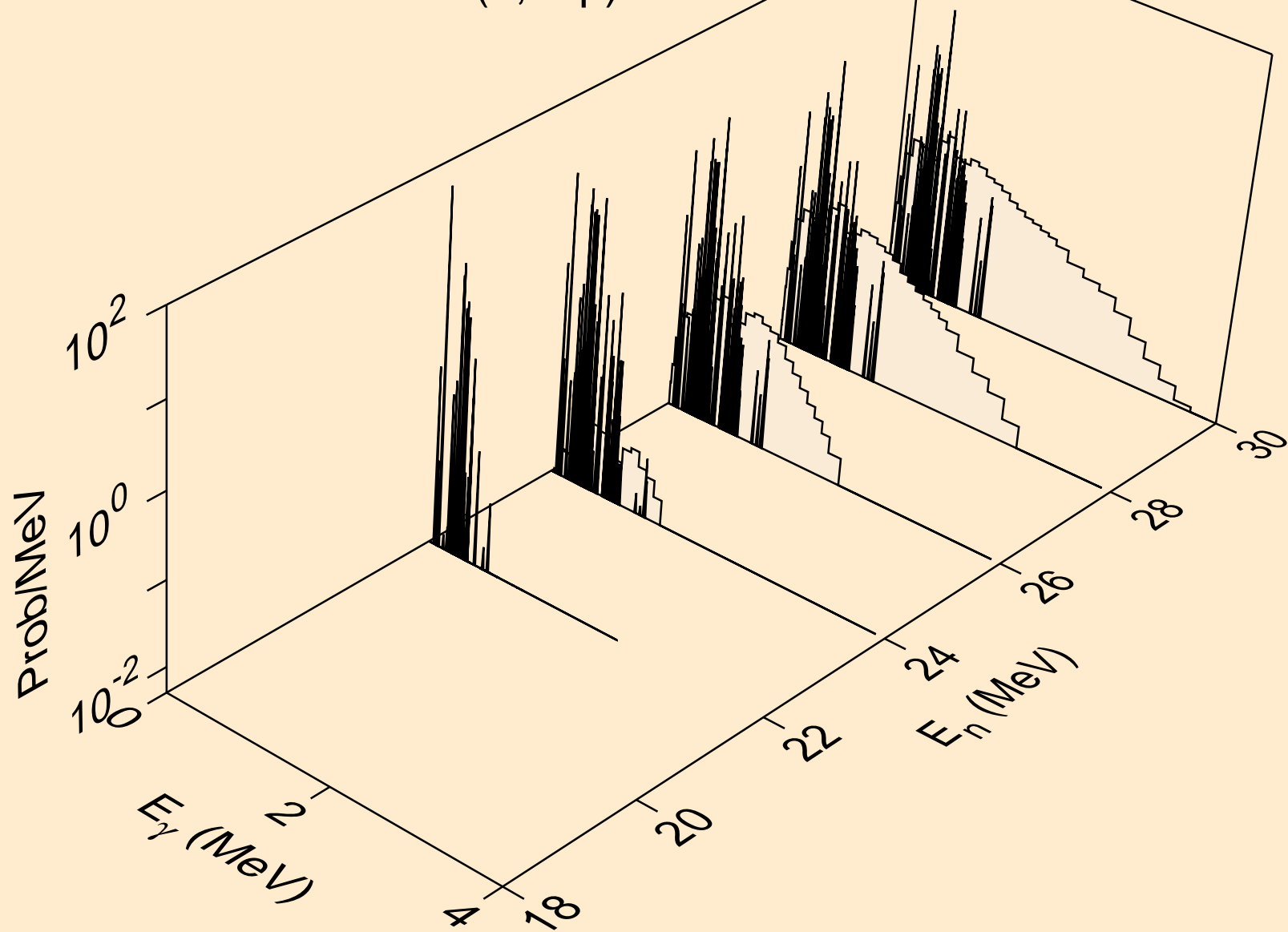

RH106 ALPHA ACER TENDL-2024 LIBRARY; T=0.K
Photon emission for (n,3np)

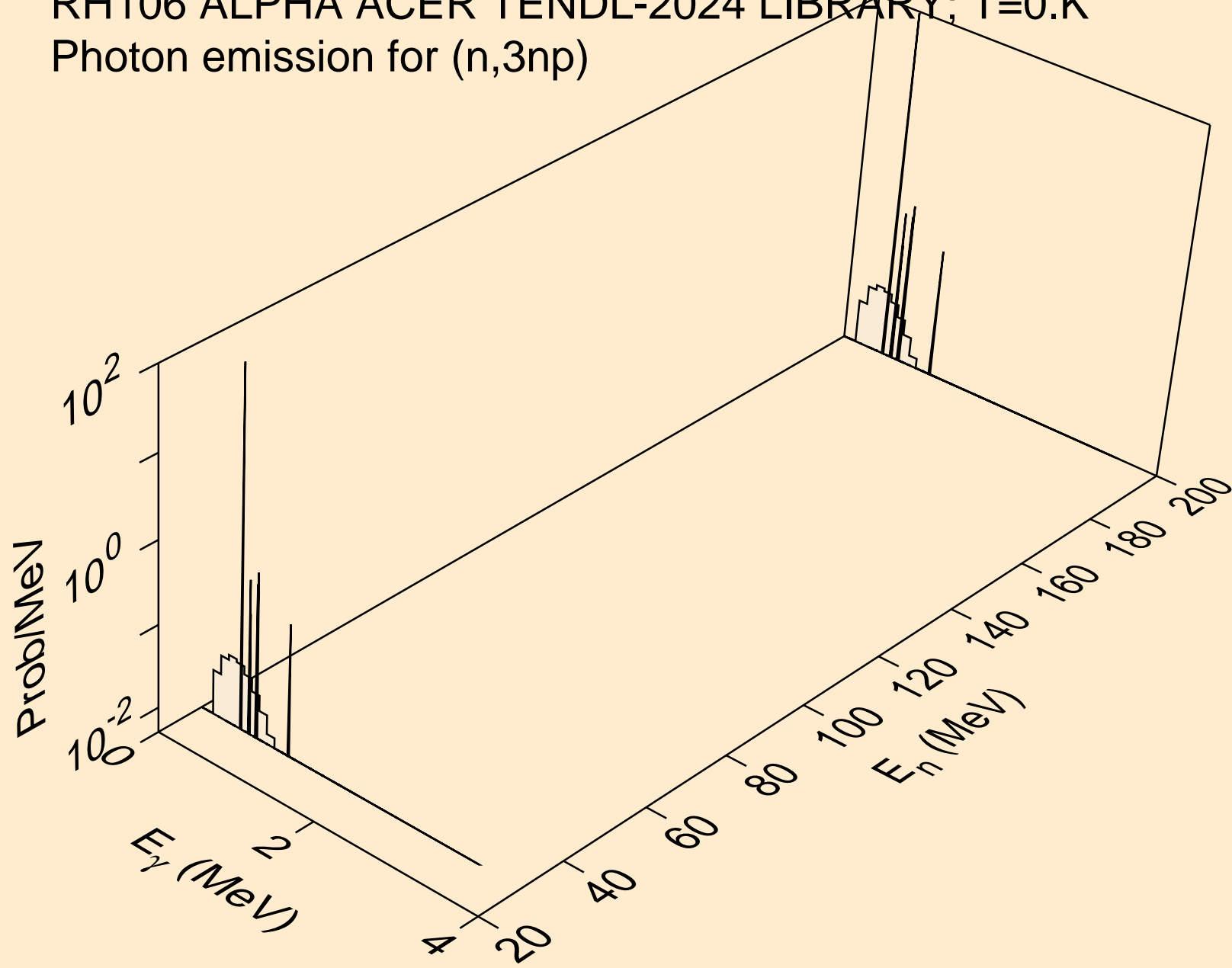

RH106 ALPHA ACER TENDL-2024 LIBRARY; T=0.K
Photon emission for (n,n2p)

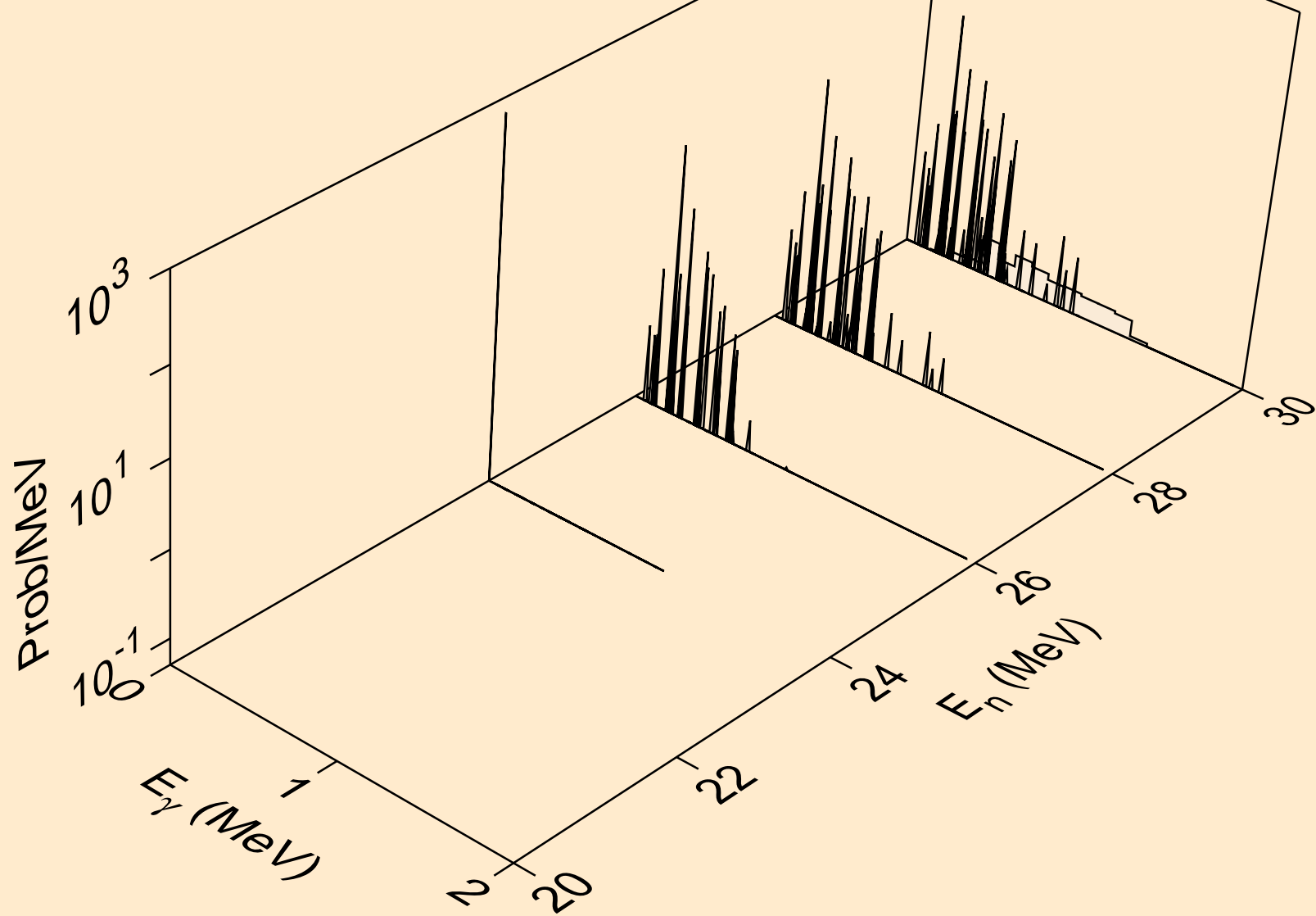

RH106 ALPHA ACER TENDL-2024 LIBRARY; T=0.K
Photon emission for (n,npa)

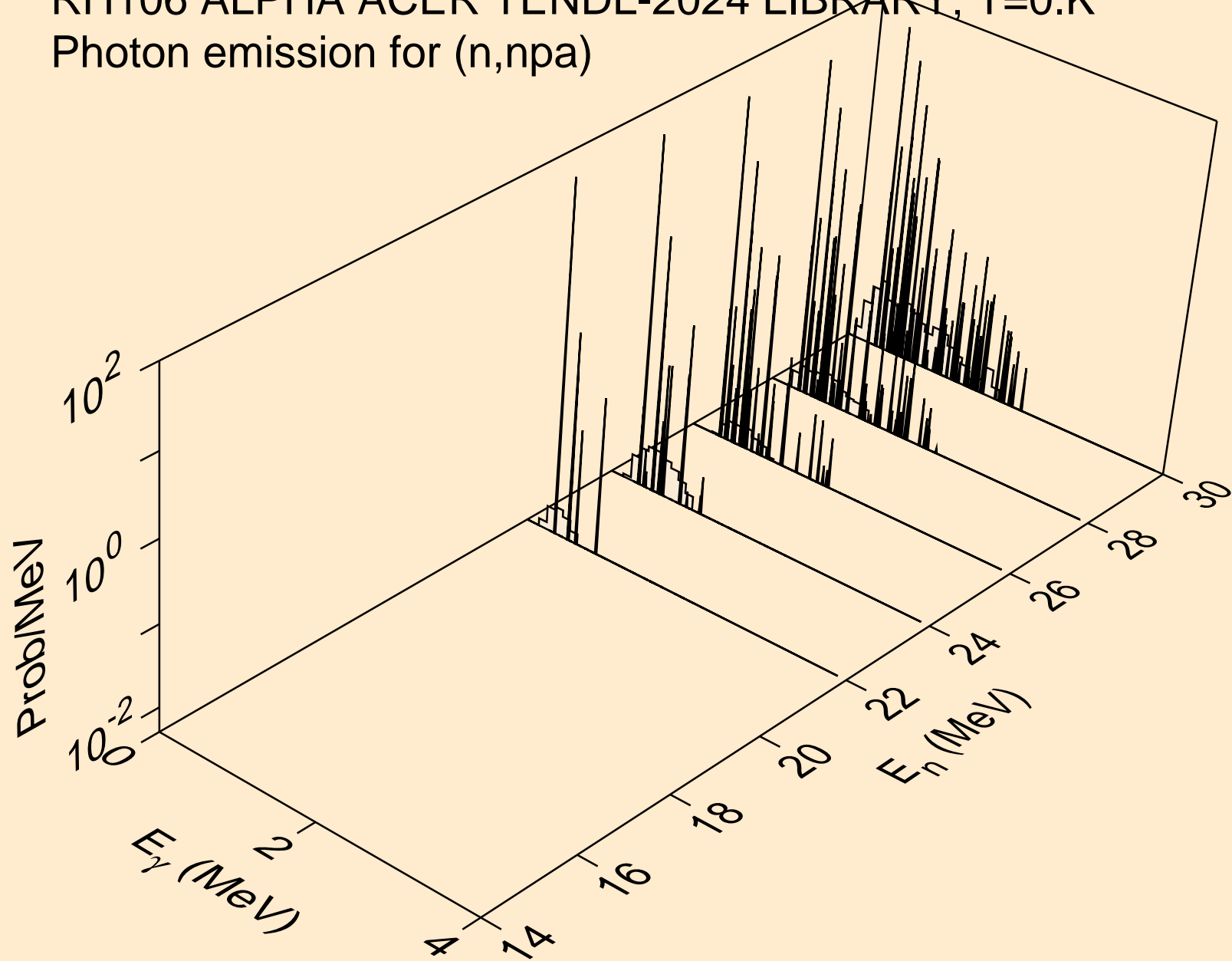

RH106 ALPHA ACER TENDL-2024 LIBRARY; T=0.K
Photon emission for (n,gma)

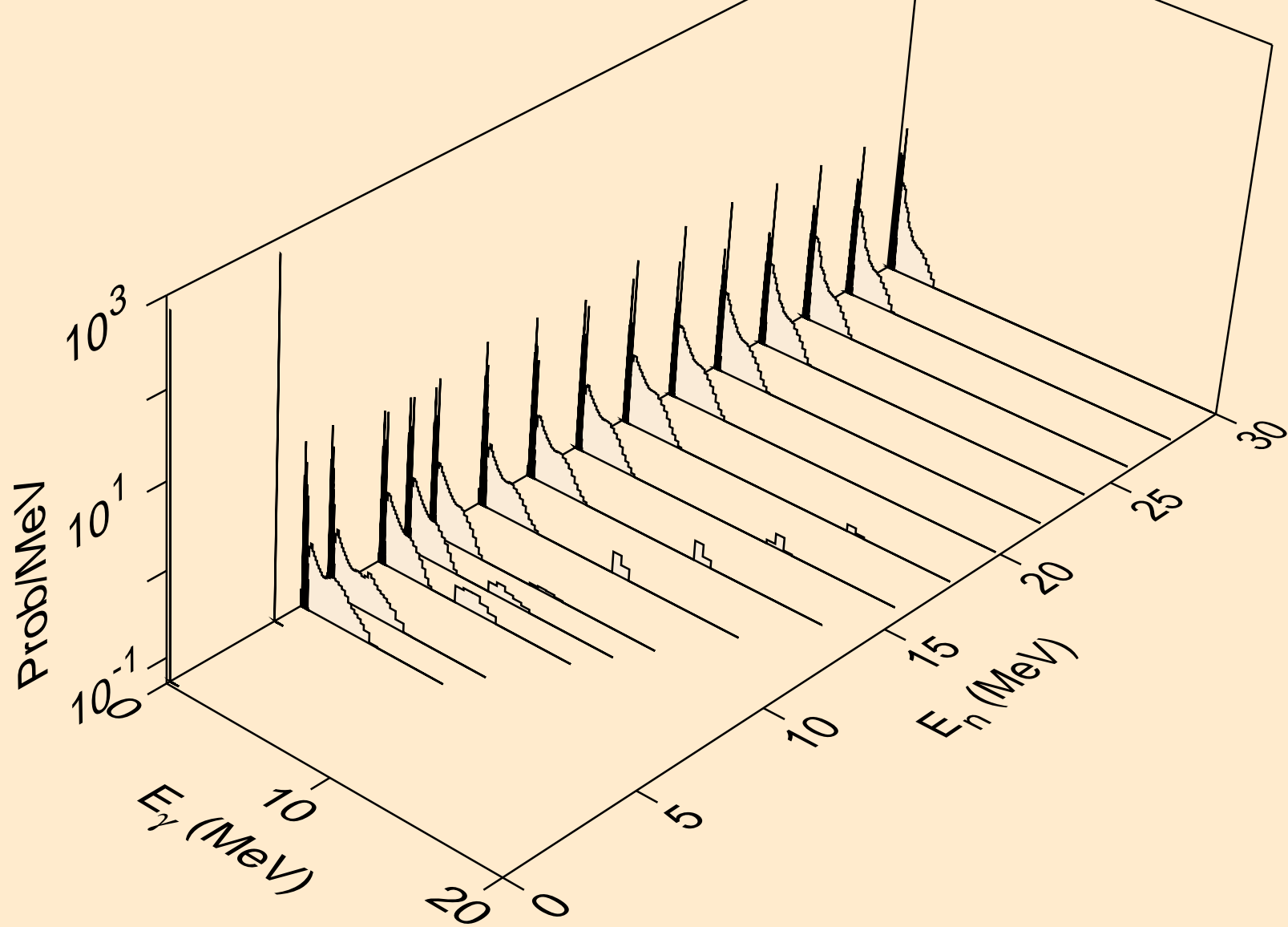

RH106 ALPHA ACER TENDL-2024 LIBRARY; T=0.K
Photon emission for (n,p)

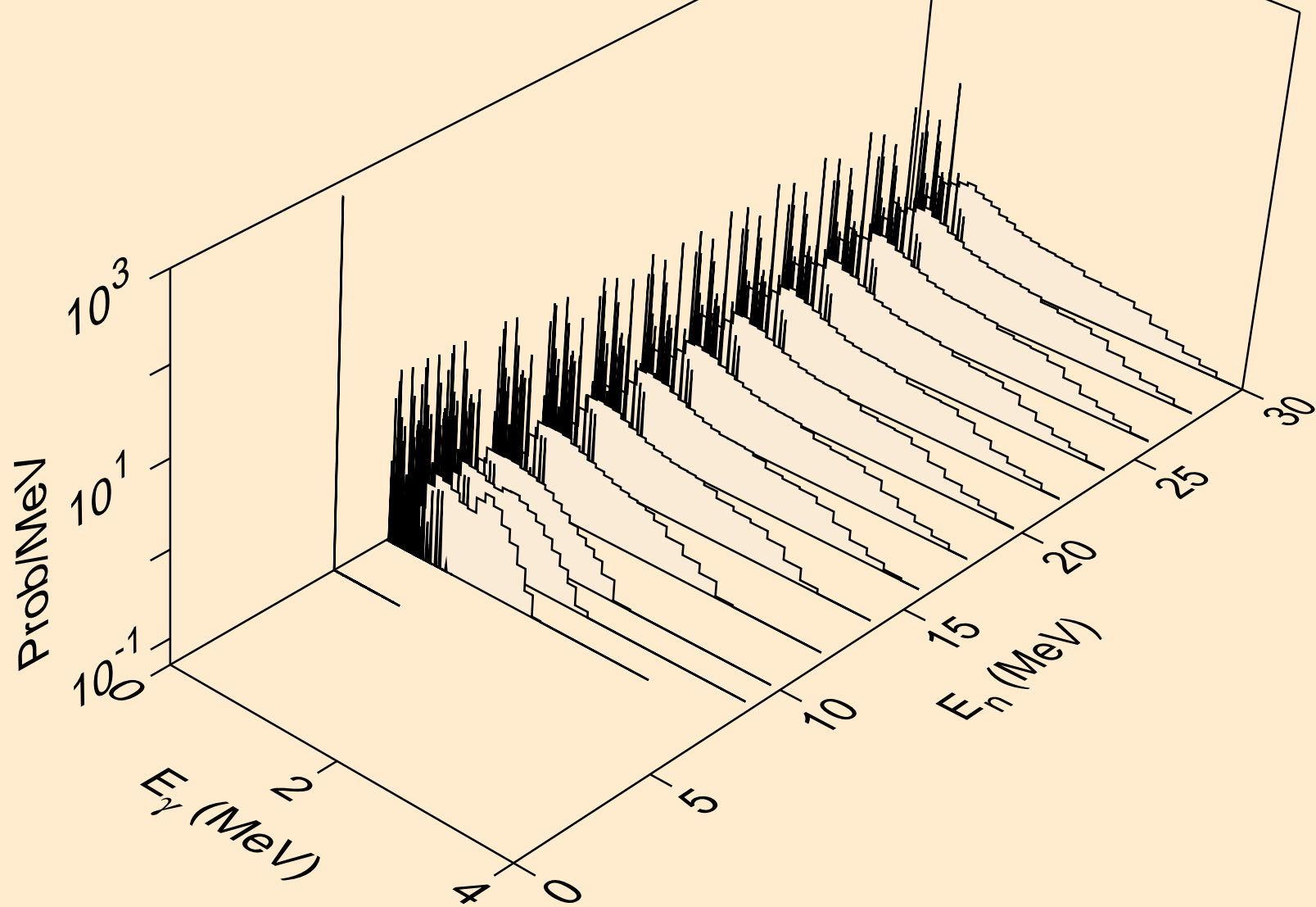

RH106 ALPHA ACER TENDL-2024 LIBRARY; T=0.K
Photon emission for (n,d)

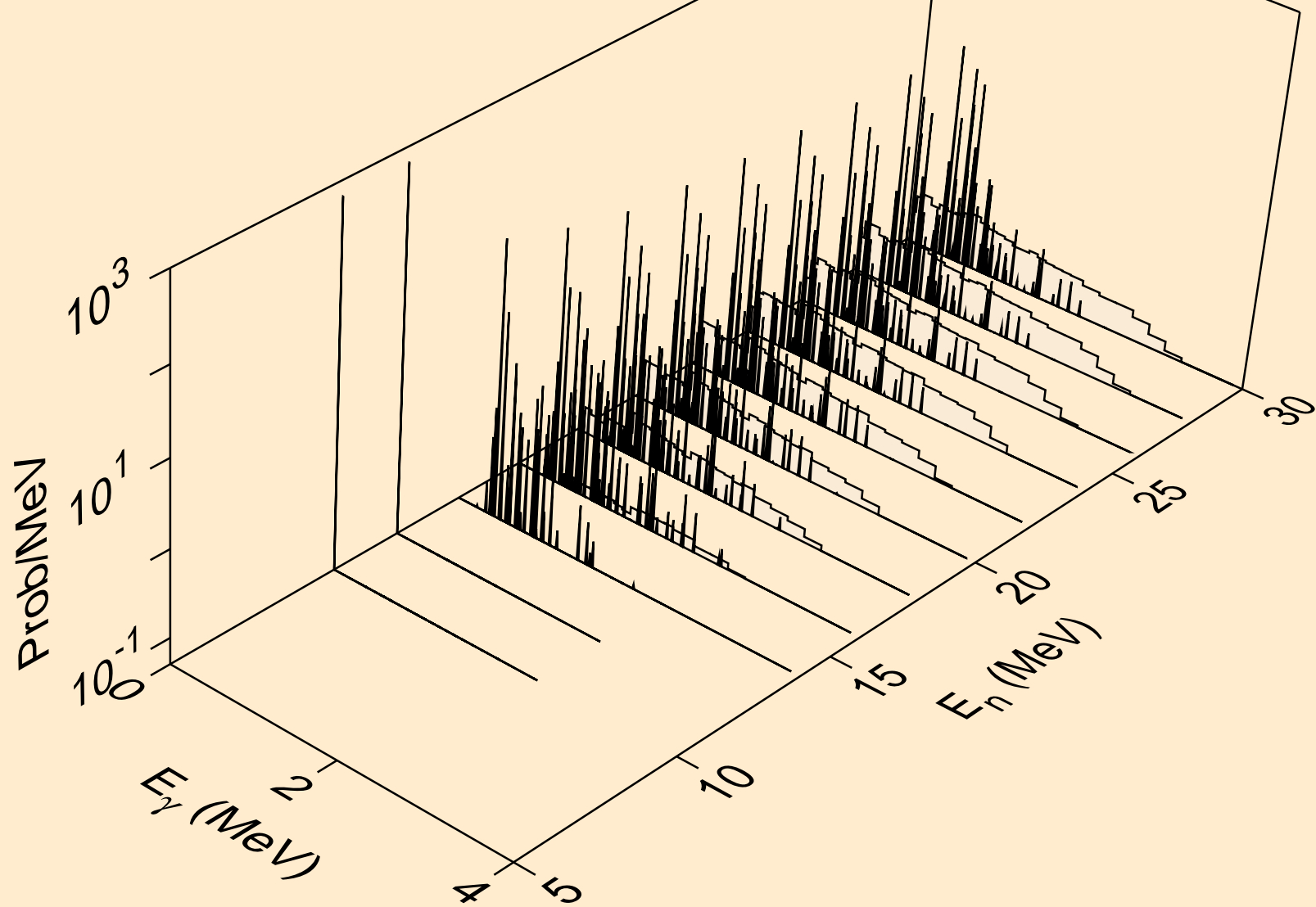

RH106 ALPHA ACER TENDL-2024 LIBRARY; T=0.K
Photon emission for (n,t)

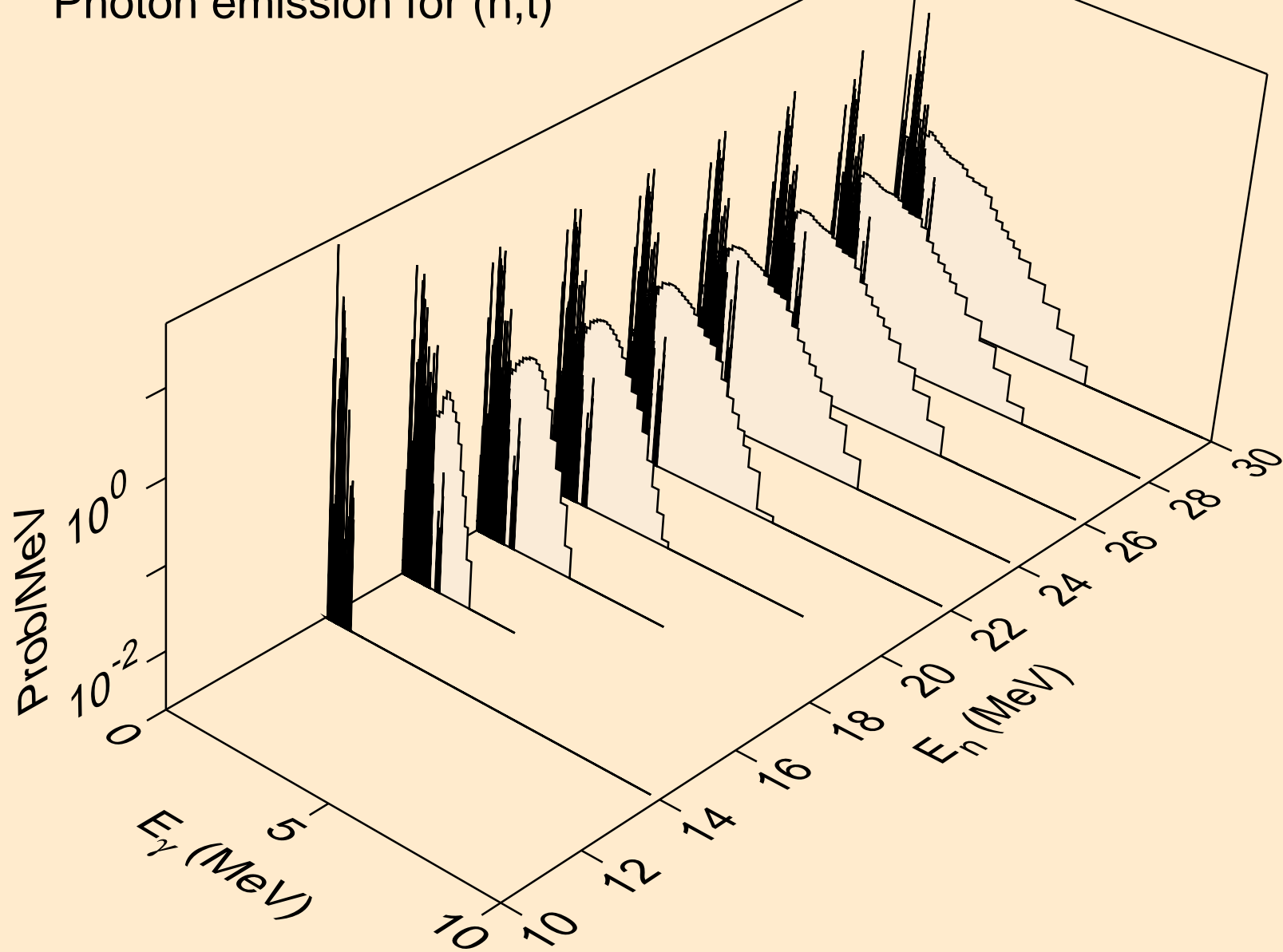

RH106 ALPHA ACER TENDL-2024 LIBRARY; T=0.K
Photon emission for (n,he3)

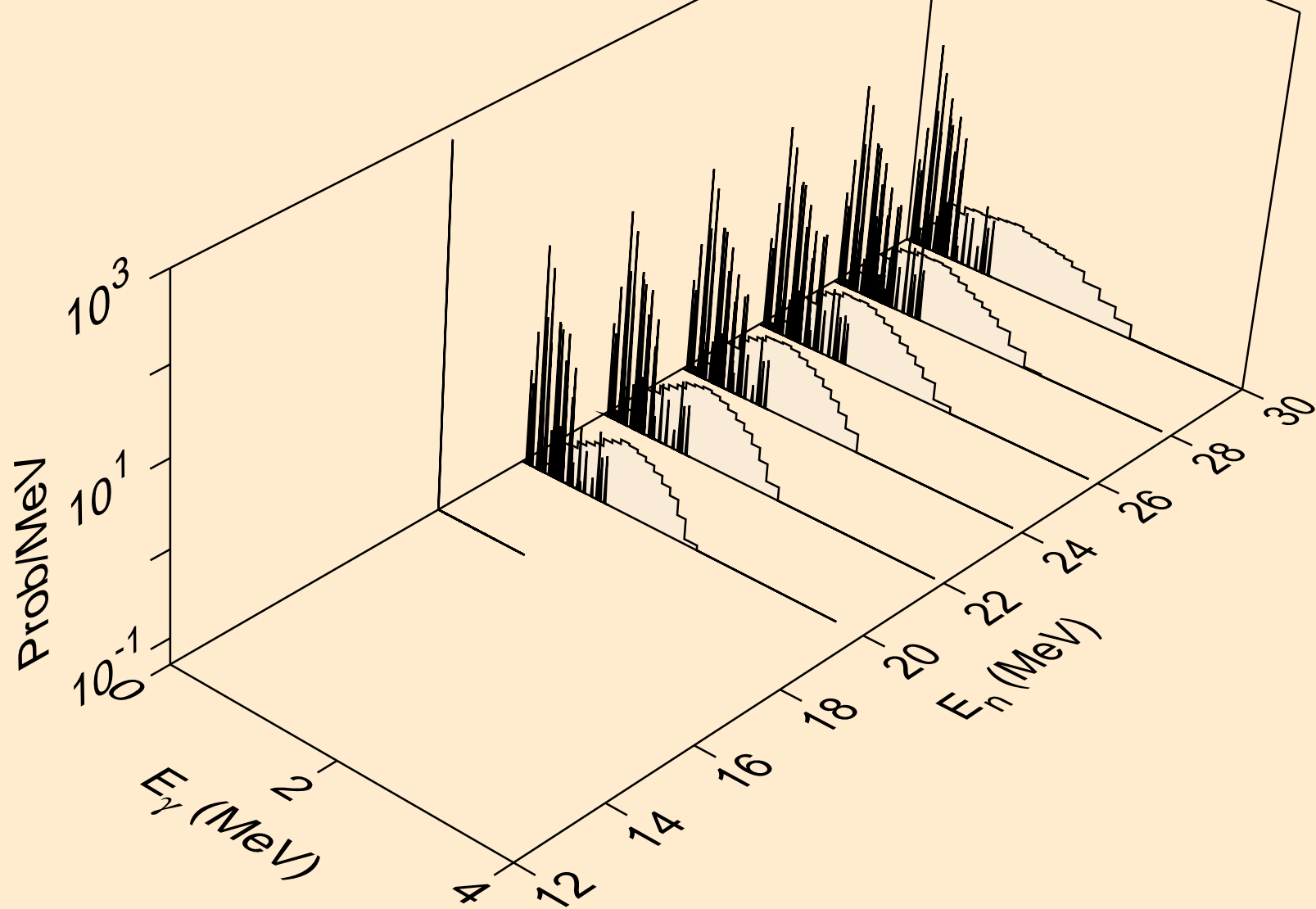

RH106 ALPHA ACER TENDL-2024 LIBRARY; T=0.K
Photon emission for inelastic

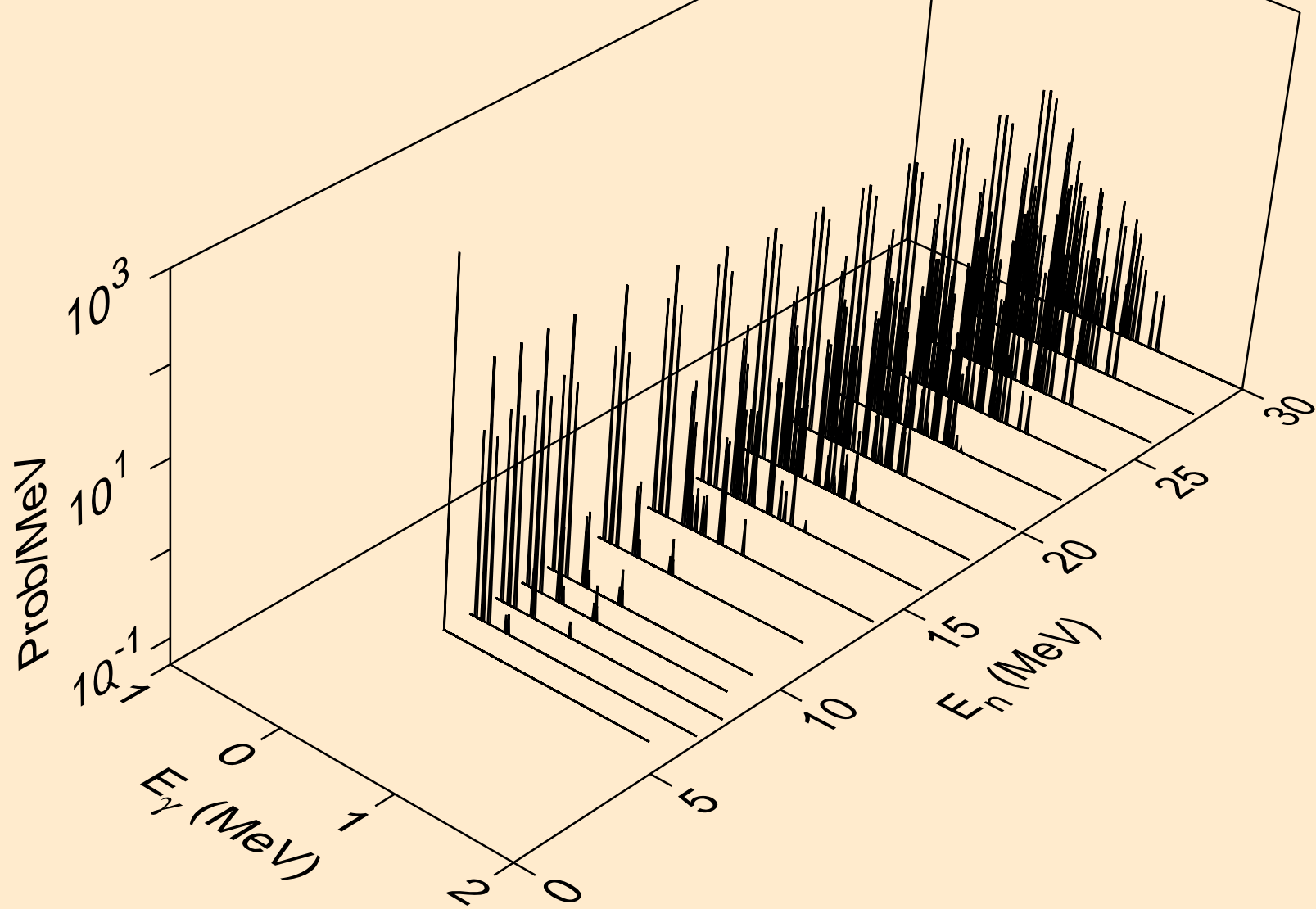

RH106 ALPHA ACER TENDL-2024 LIBRARY; T=0.K
Photon emission for (n,2a)

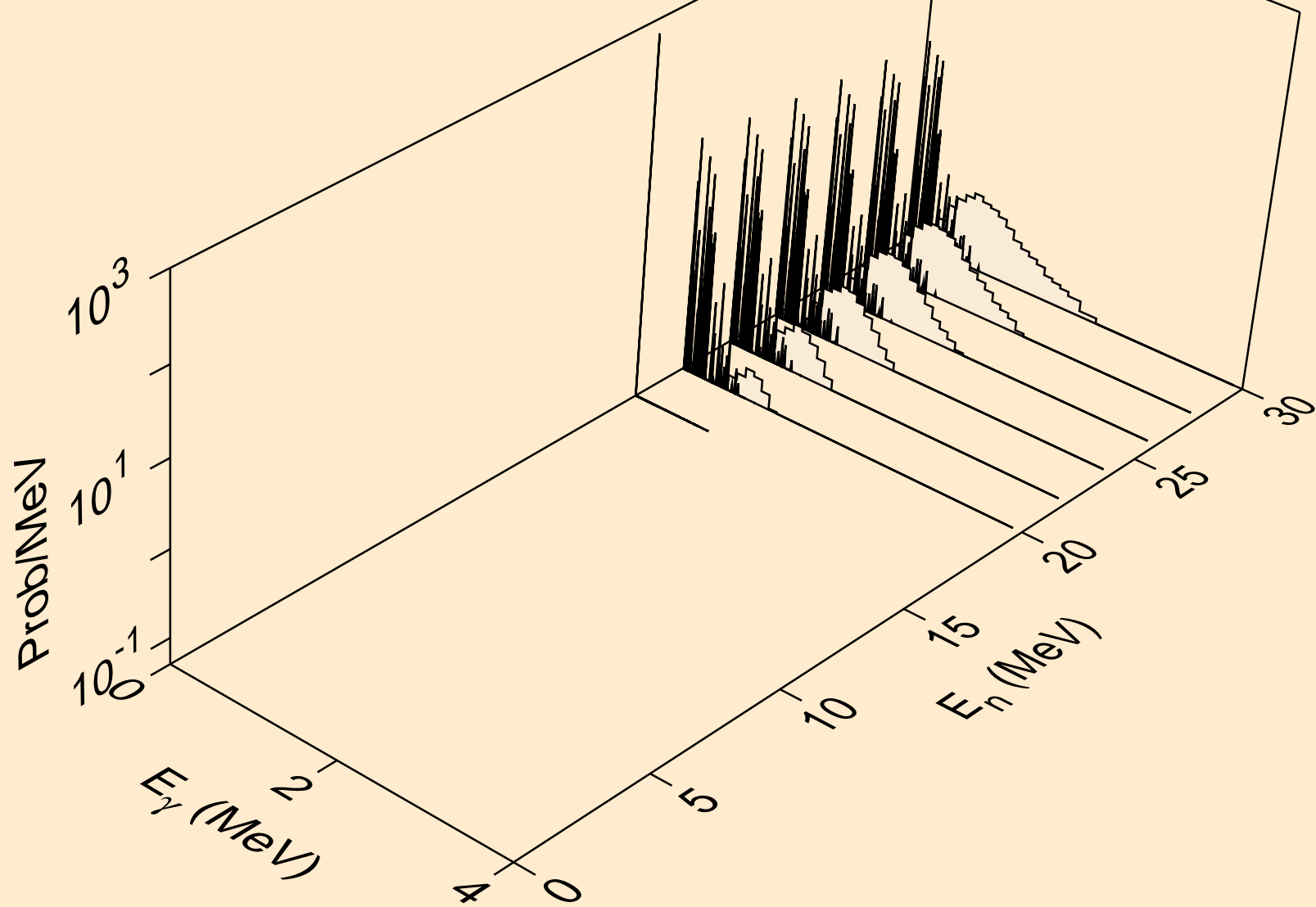

RH106 ALPHA ACER TENDL-2024 LIBRARY; T=0.K
Photon emission for (n,2p)

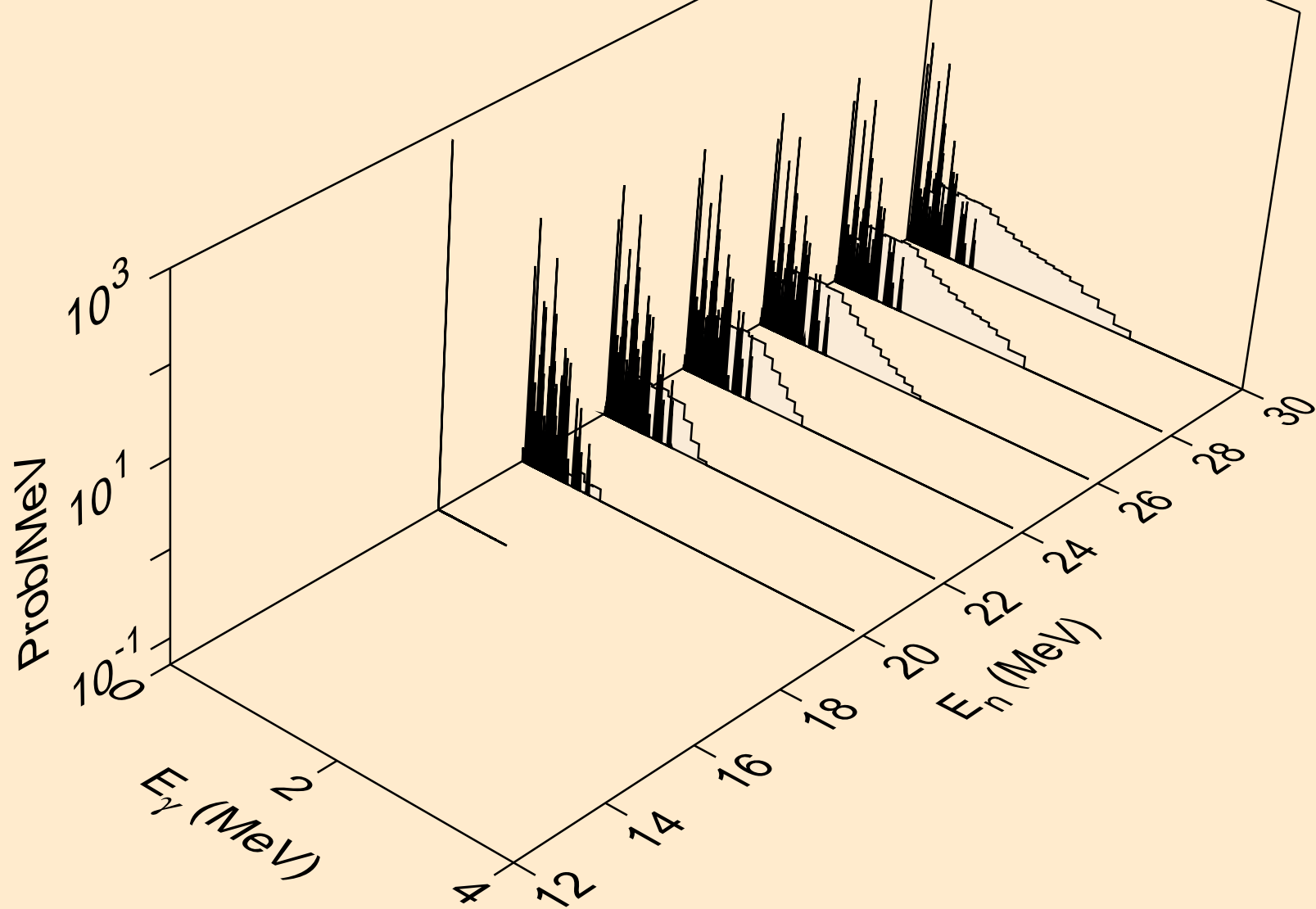

RH106 ALPHA ACER TENDL-2024 LIBRARY; T=0.K
Photon emission for (n,pa)

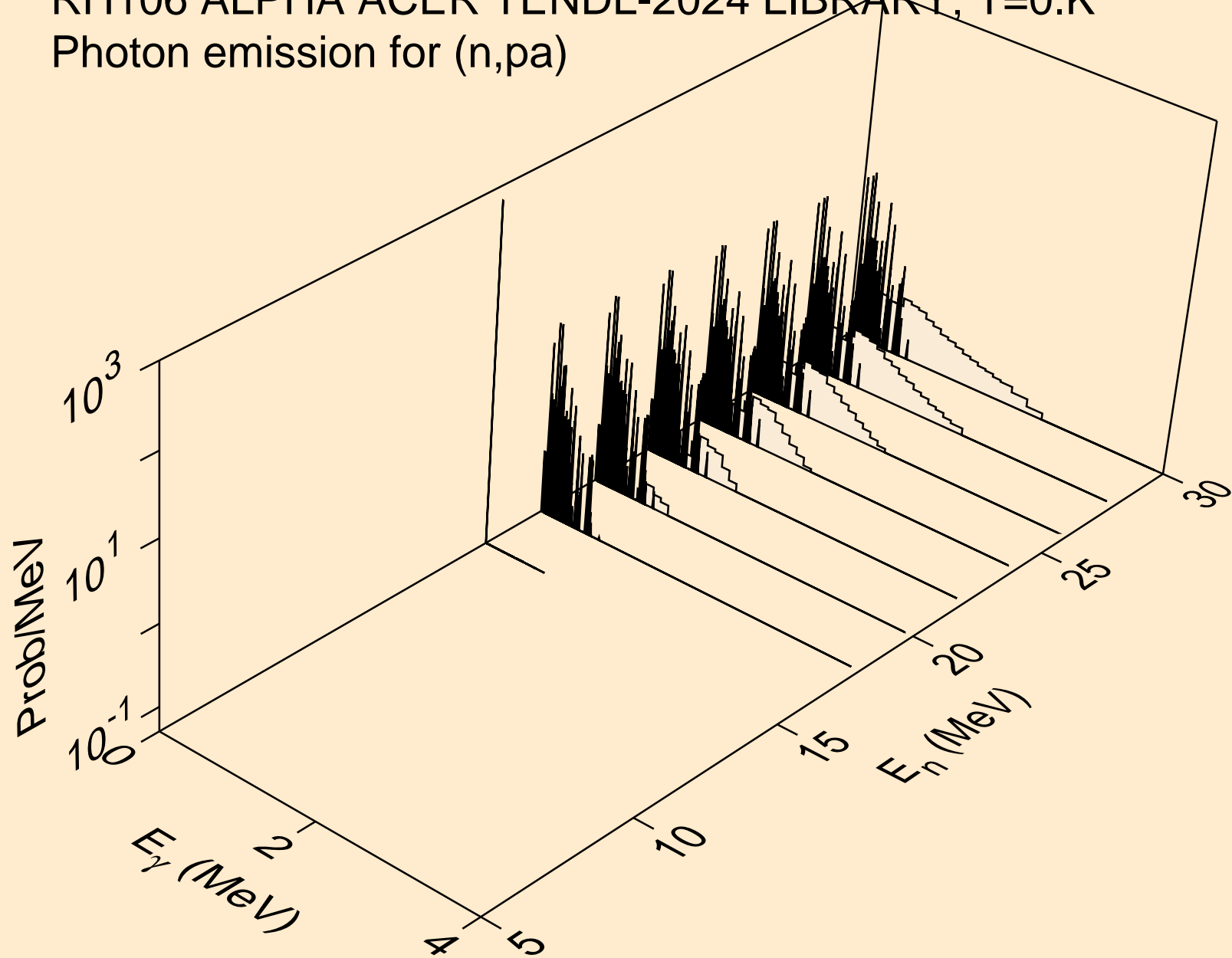

RH106 ALPHA ACER TENDL-2024 LIBRARY; T=0.K
Photon emission for (n,pd)

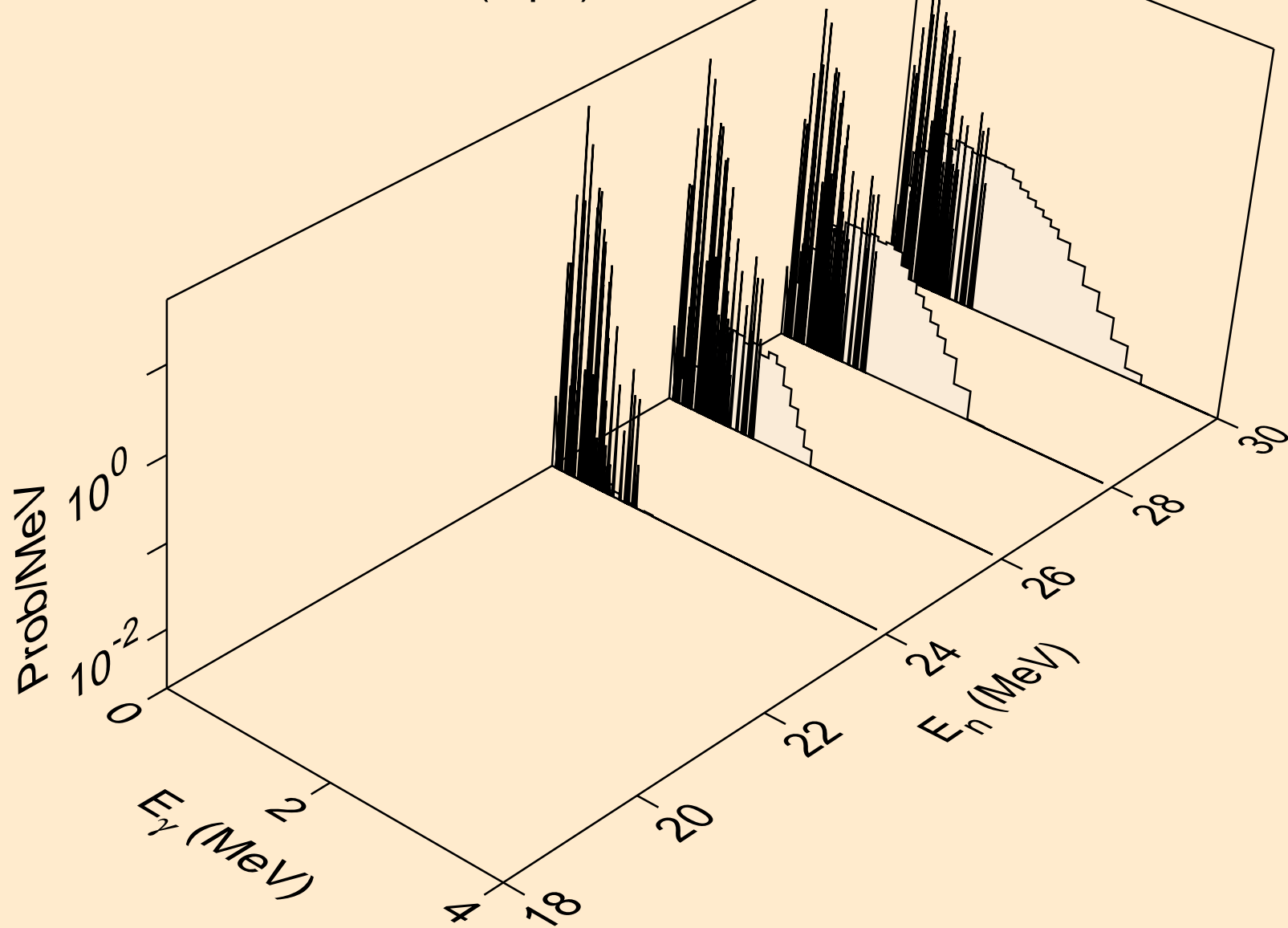

RH106 ALPHA ACER TENDL-2024 LIBRARY; T=0.K
Photon emission for (n,da)

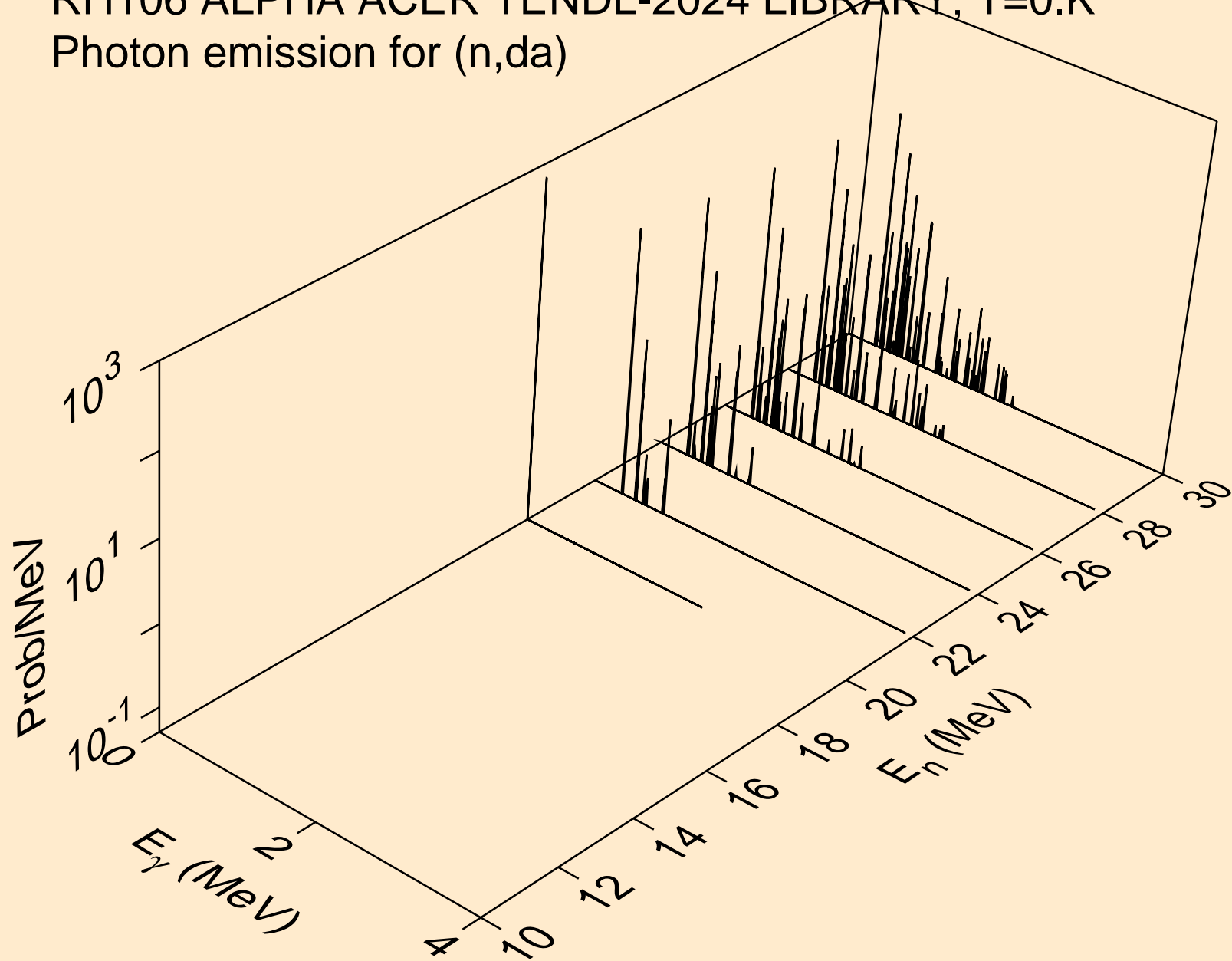

RH106 ALPHA ACER TENDL-2024 LIBRARY; T=0.K

Particle heating contributions

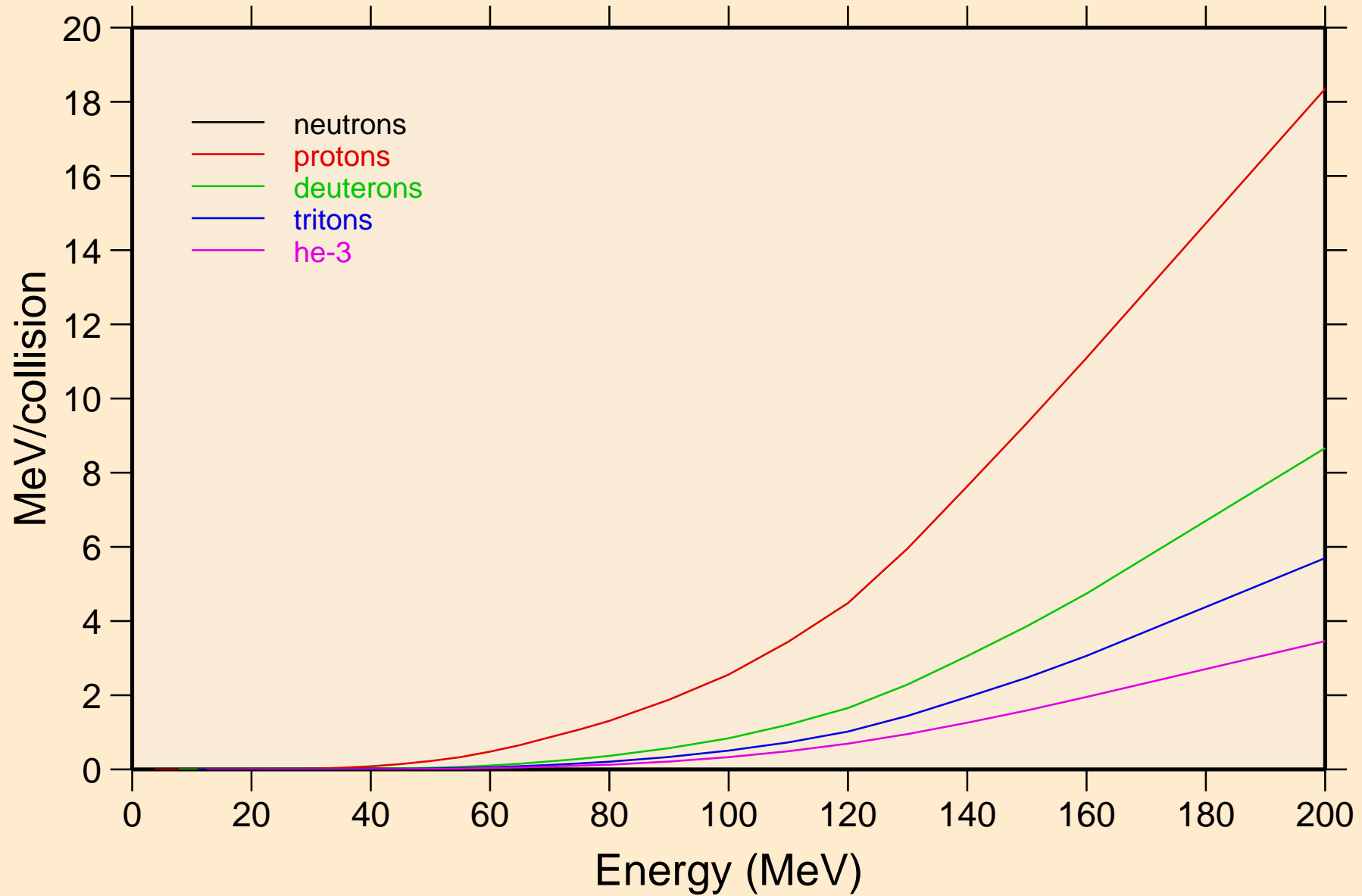

RH106 ALPHA ACER TENDL-2024 LIBRARY; T=0.K
Recoil Heating

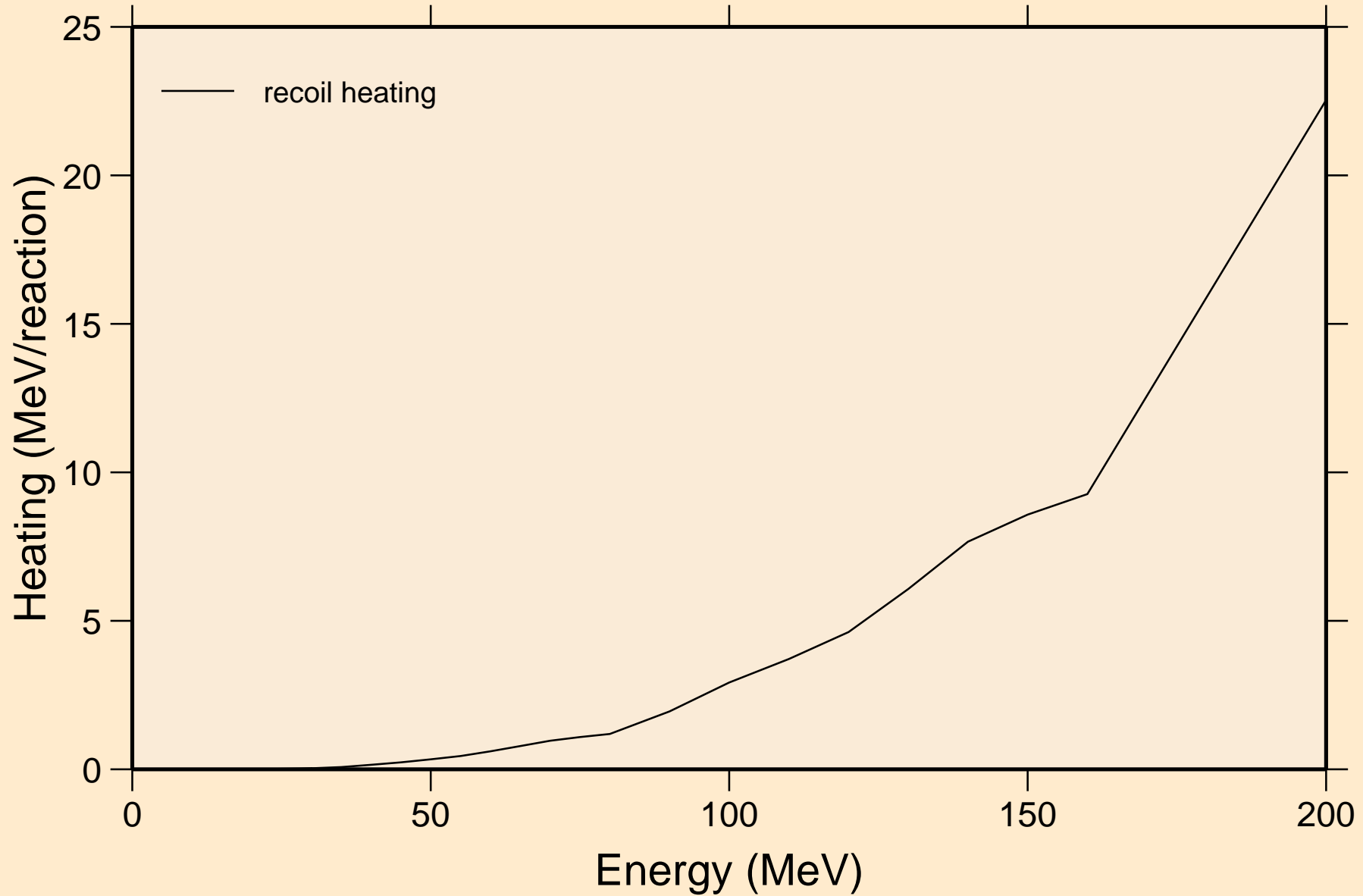

RH106 ALPHA ACER TENDL-2024 LIBRARY; T=0.K
Particle production cross sections

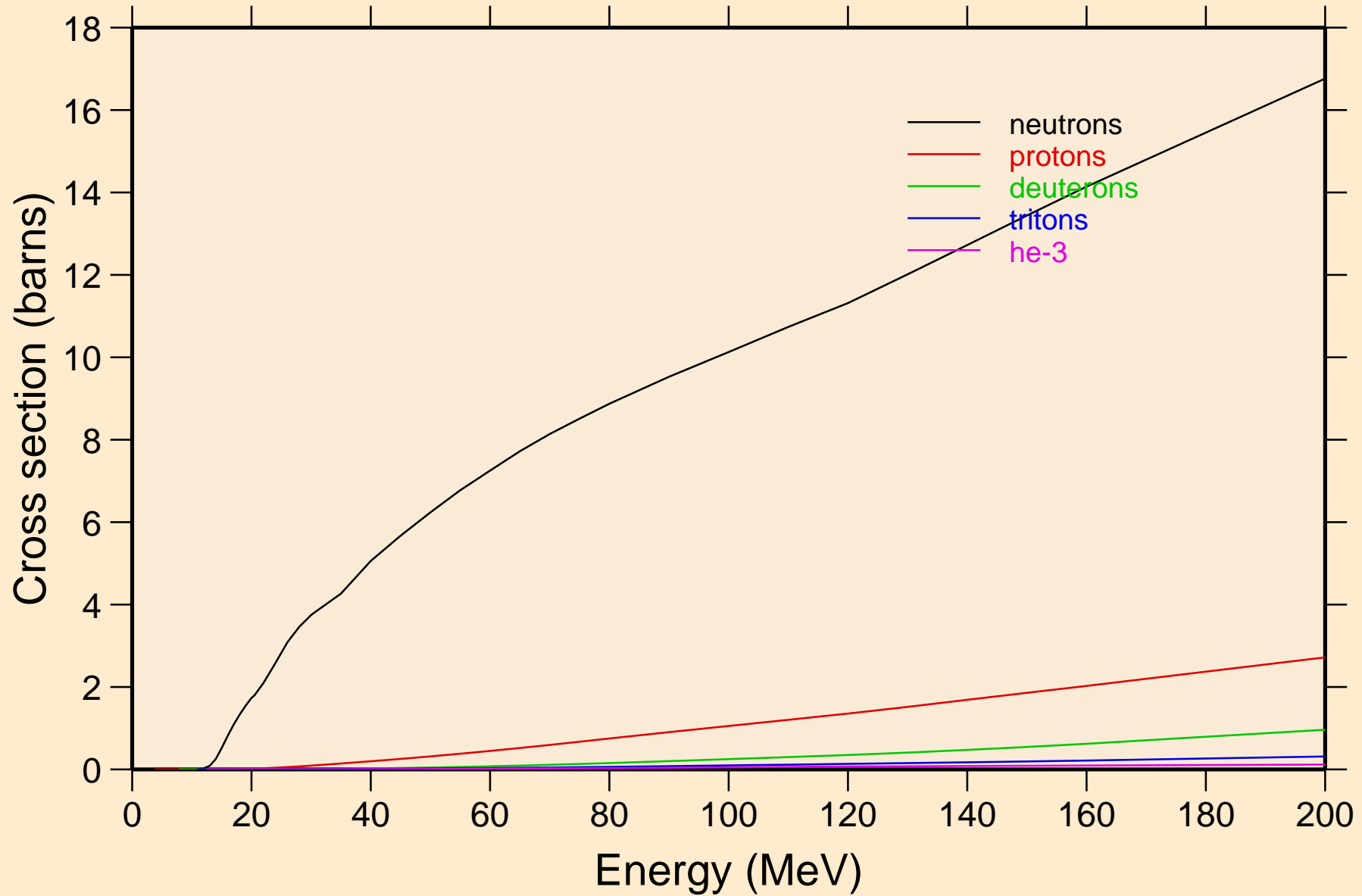

RH106 ALPHA ACER TENDL-2024 LIBRARY; T=0.K
neutrons from (a,n)

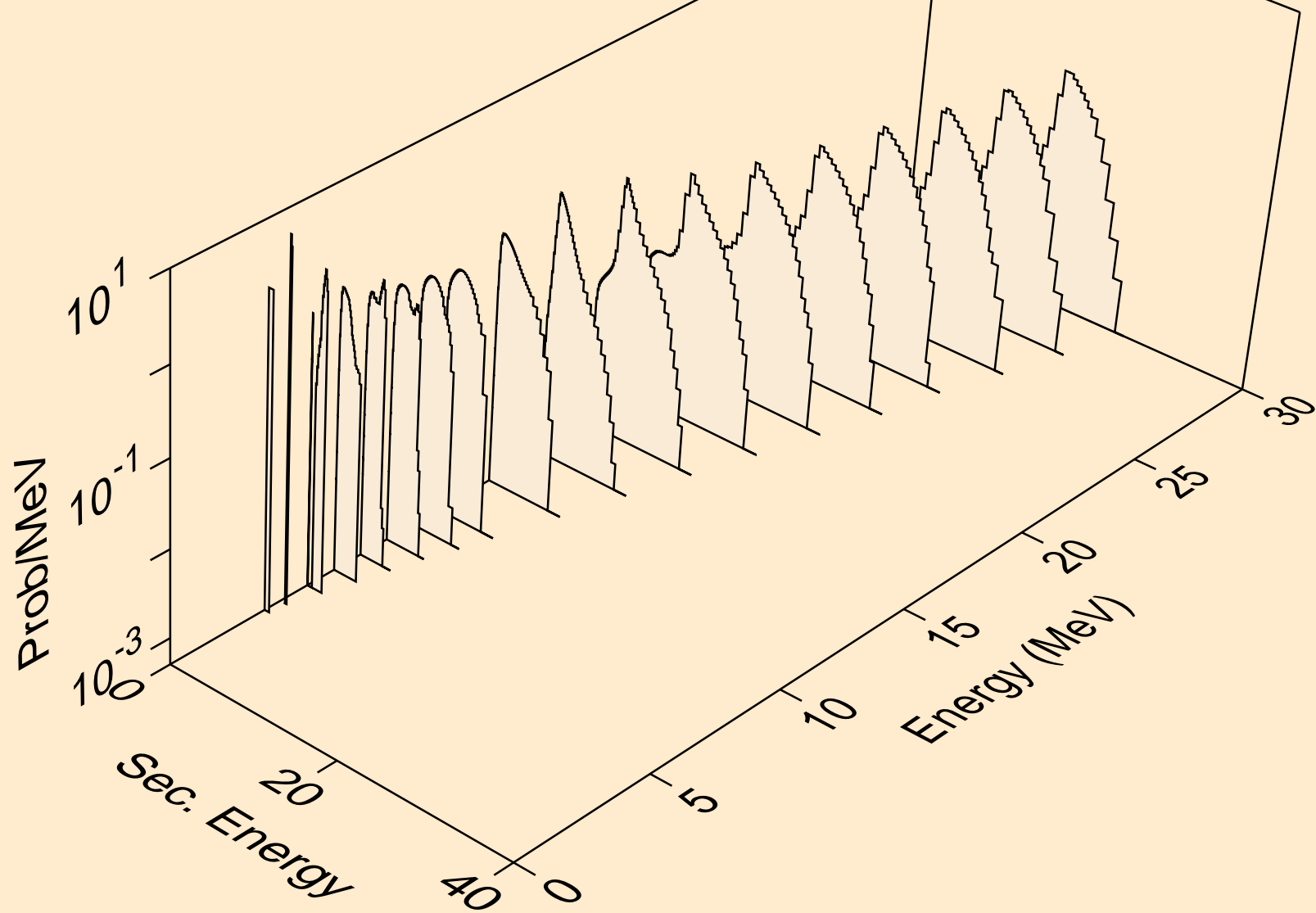

RH106 ALPHA ACER TENDL-2024 LIBRARY; T=0.K
neutrons from (a,x)

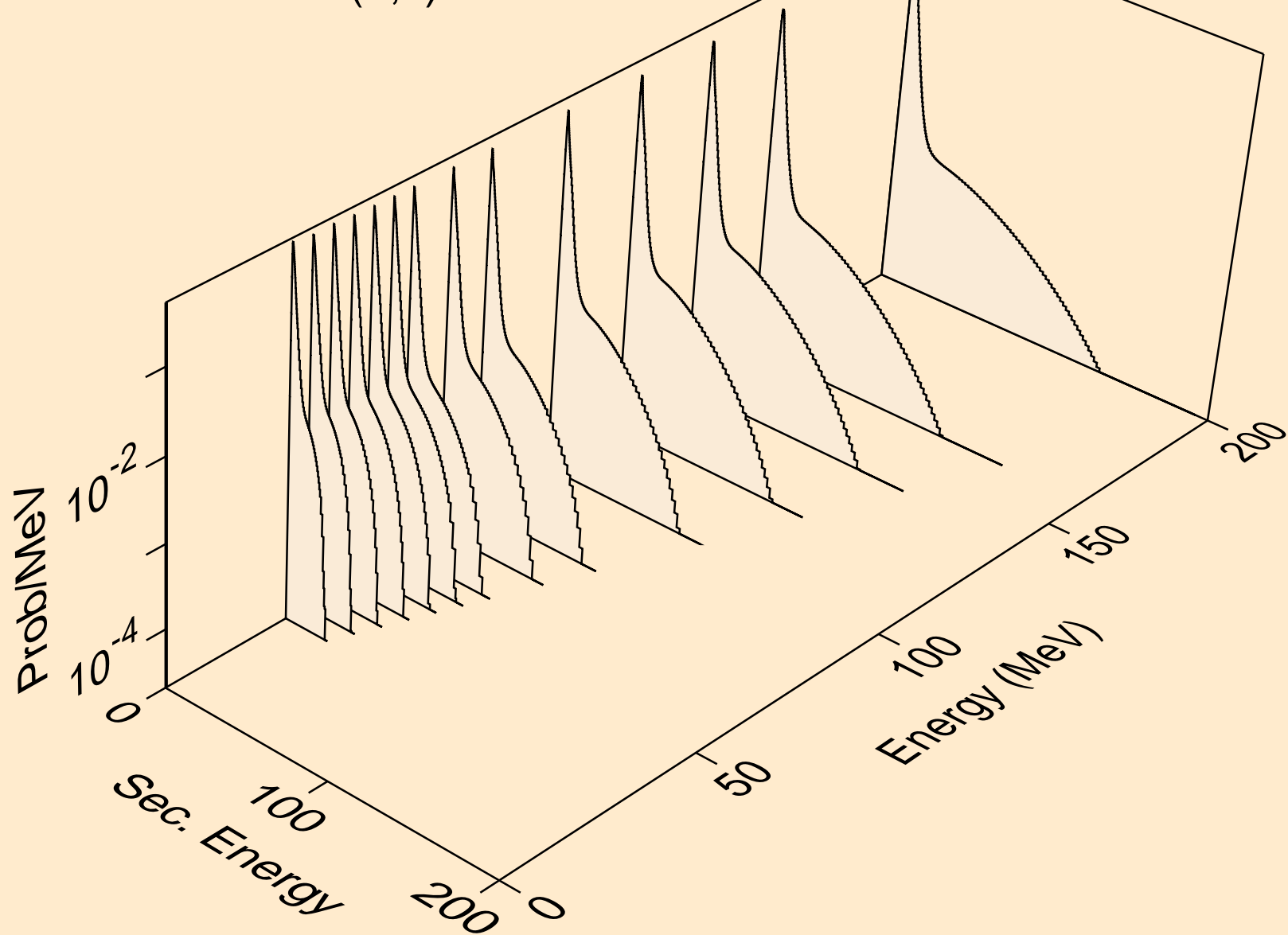

RH106 ALPHA ACER TENDL-2024 LIBRARY; T=0.K
neutrons from (a,2nd)

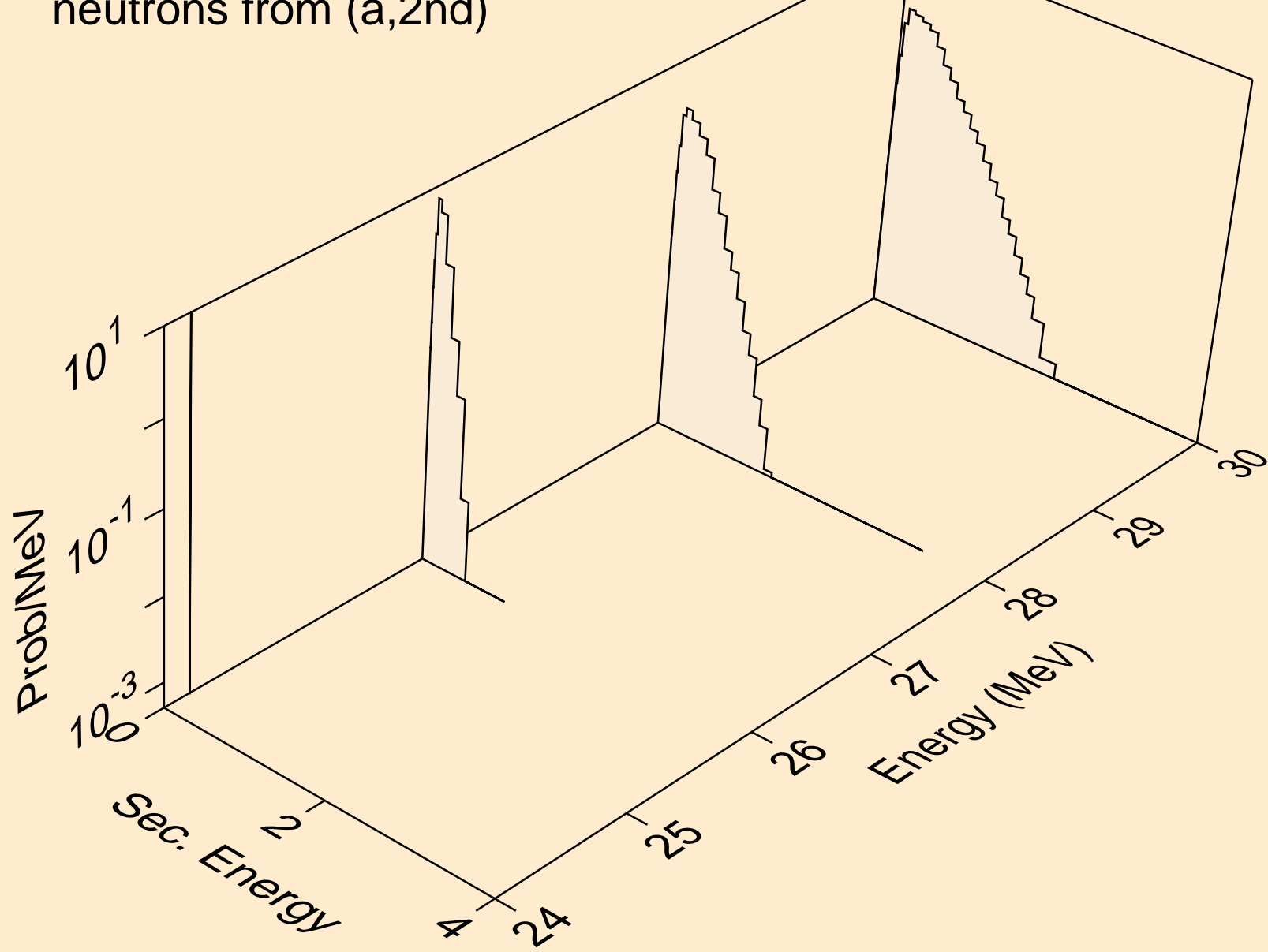

RH106 ALPHA ACER TENDL-2024 LIBRARY; T=0.K
neutrons from (a,2n)

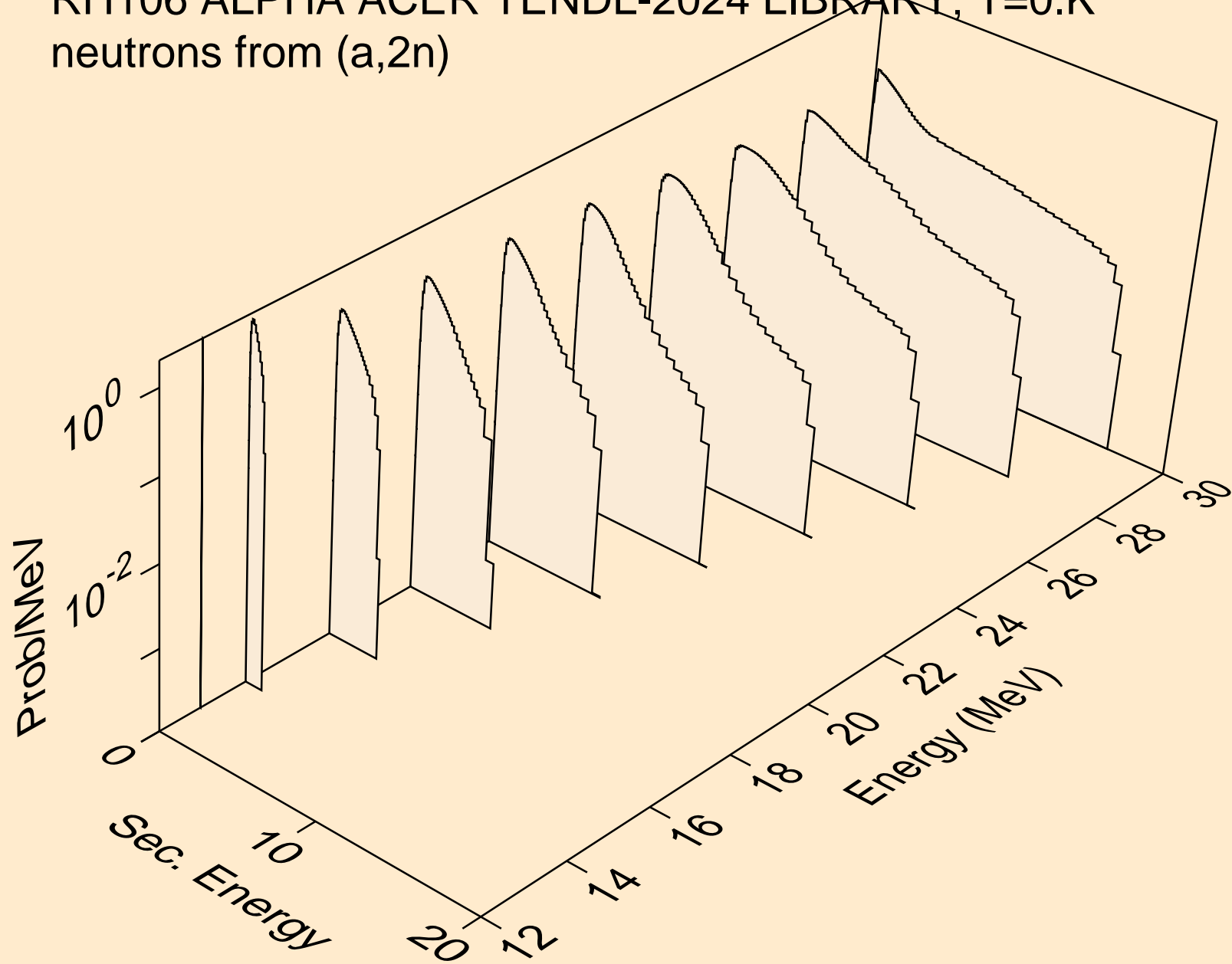

RH106 ALPHA ACER TENDL-2024 LIBRARY; T=0.K
neutrons from (a,3n)

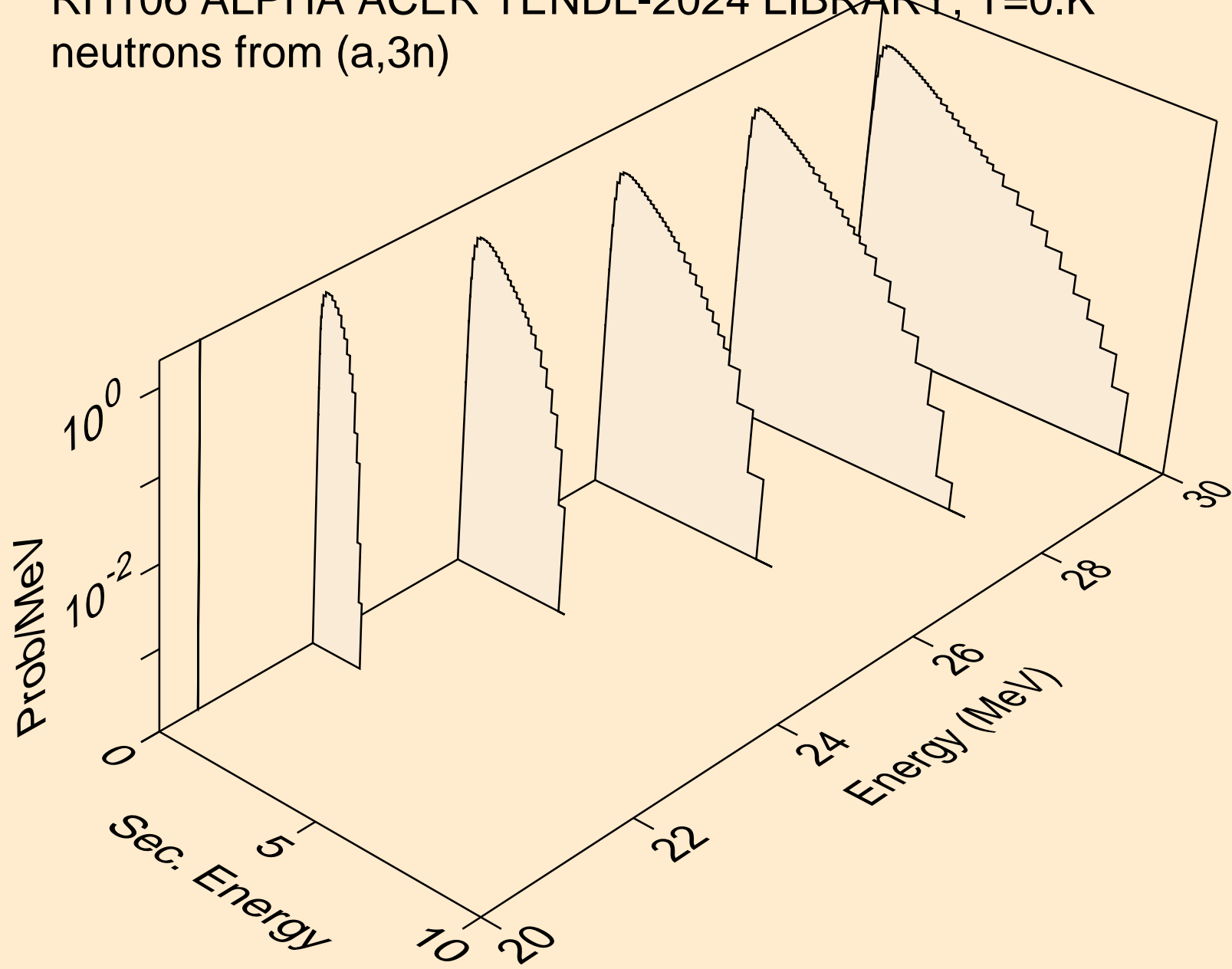

RH106 ALPHA ACER TENDL-2024 LIBRARY; T=0.K
neutrons from (a,n*)a

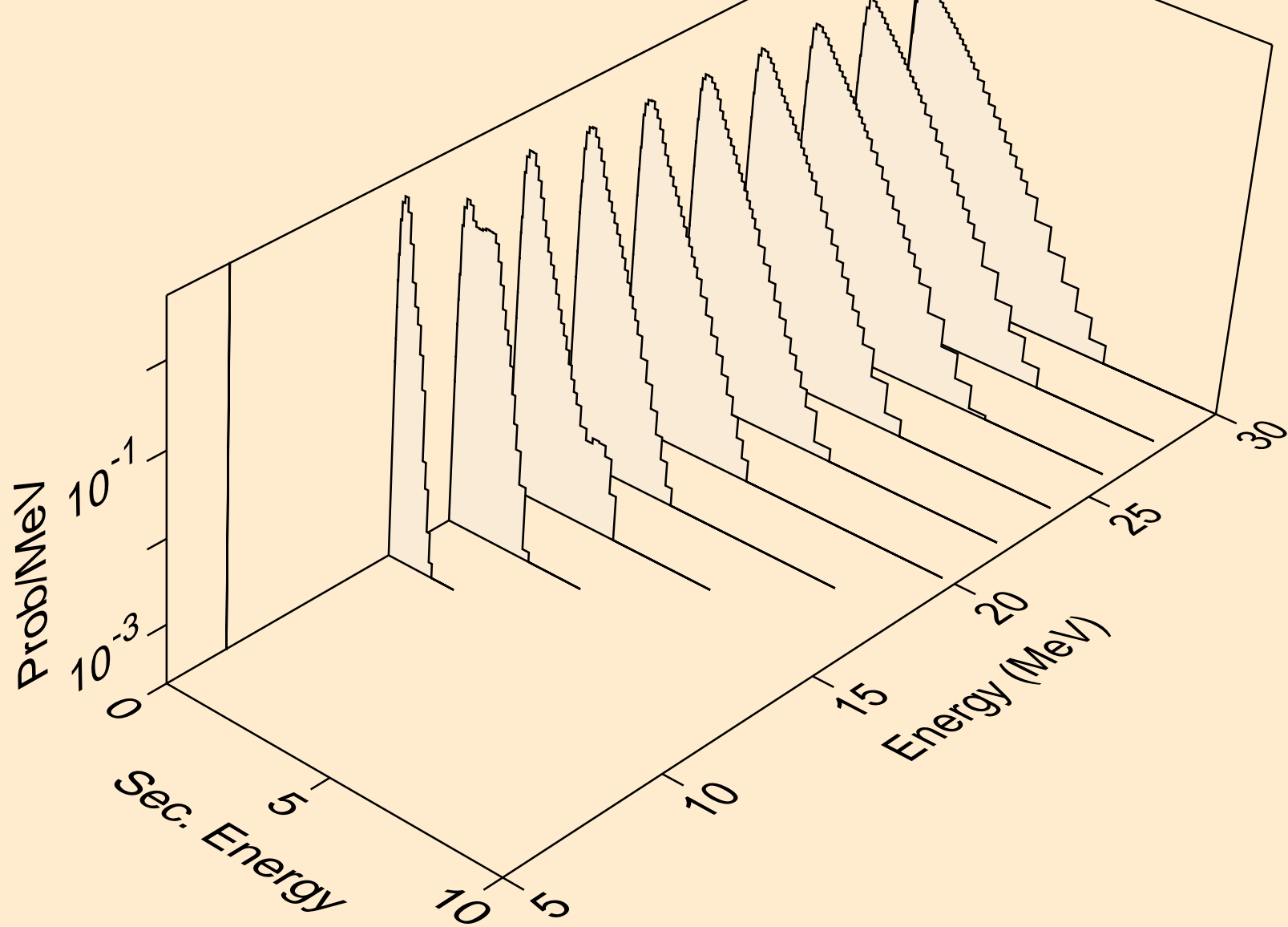

RH106 ALPHA ACER TENDL-2024 LIBRARY; T=0.K
neutrons from (a,2n)a

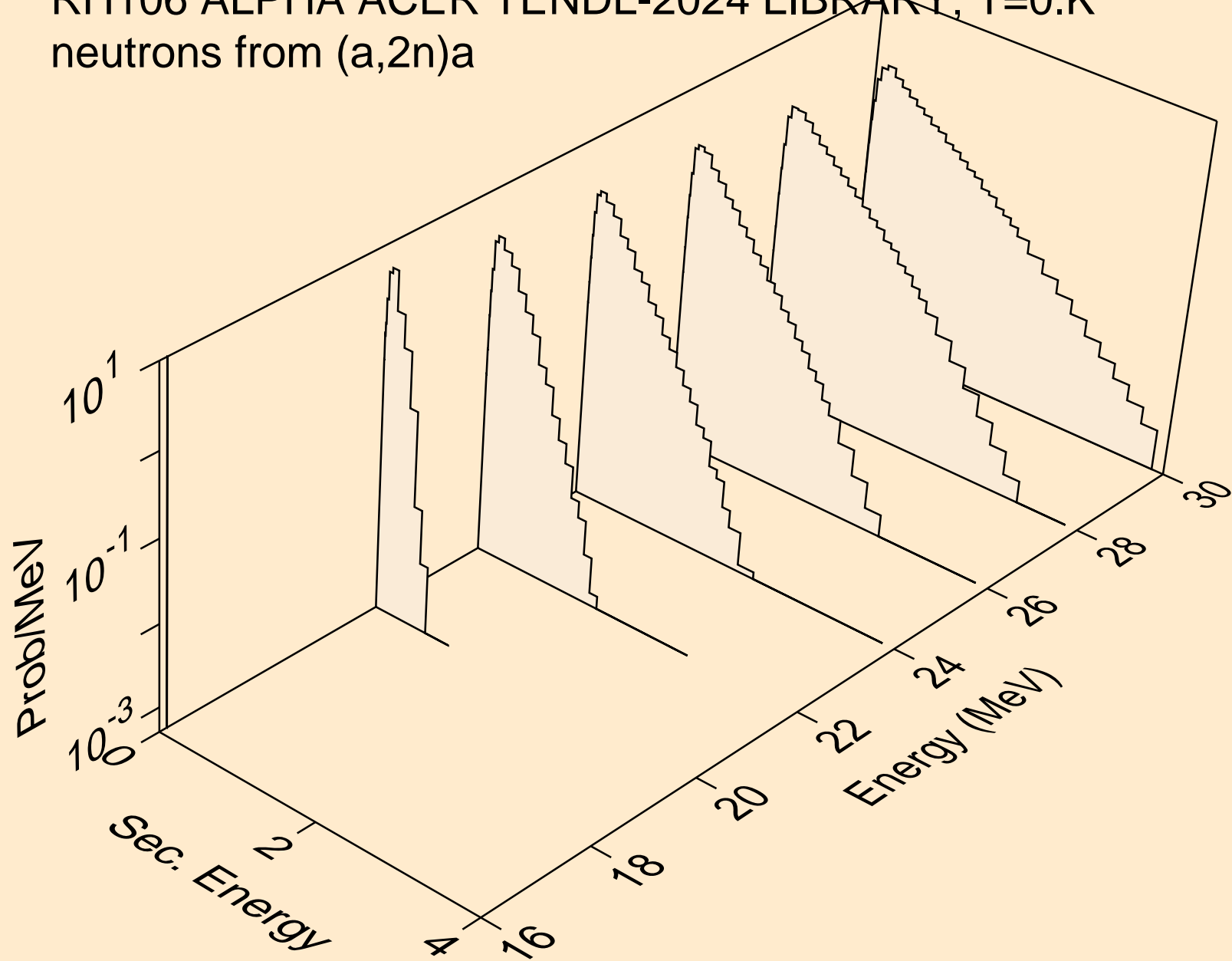

RH106 ALPHA ACER TENDL-2024 LIBRARY; T=0.K
neutrons from (a,n*)p

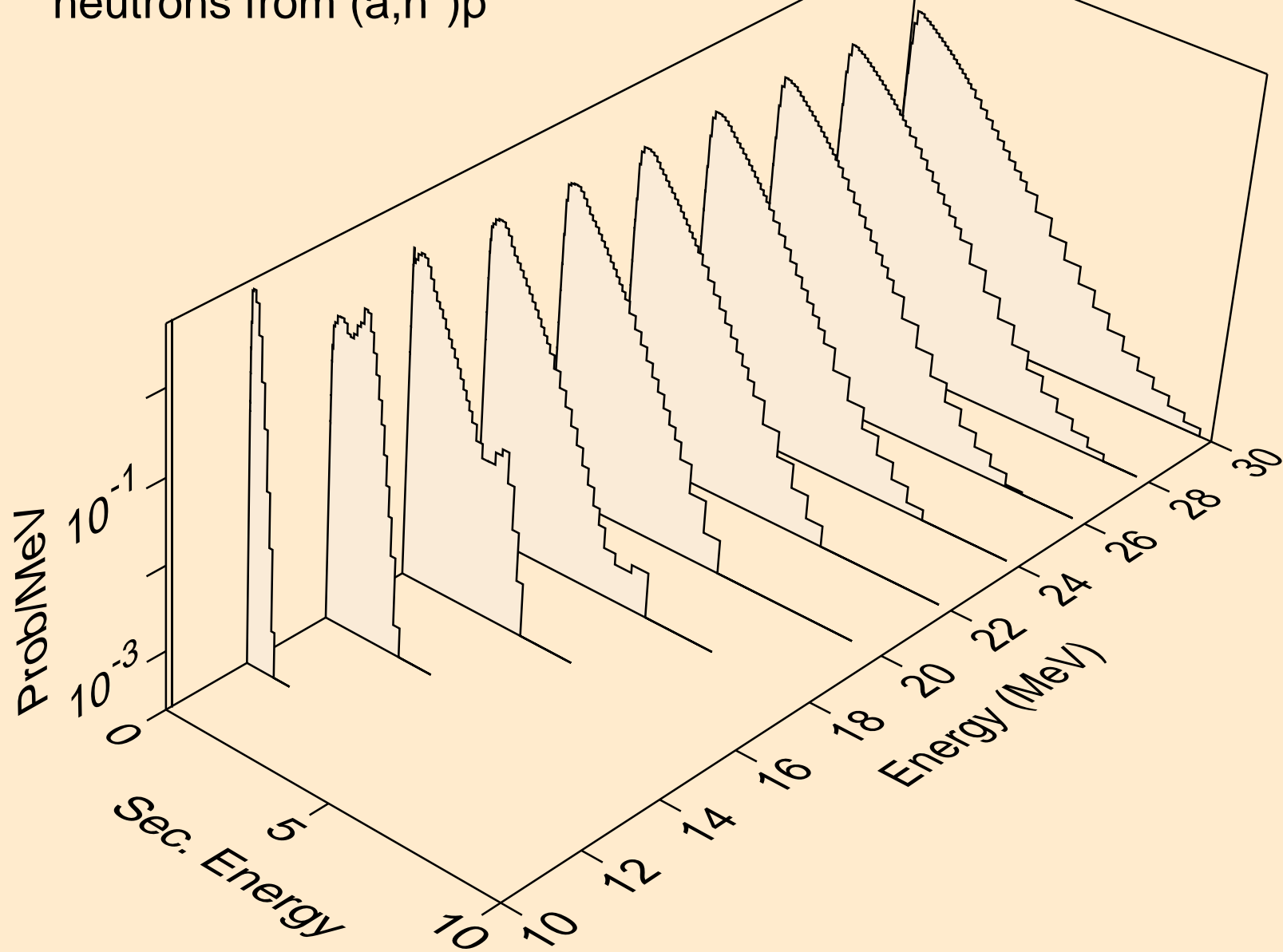

RH106 ALPHA ACER TENDL-2024 LIBRARY; T=0.K
neutrons from (a,n*)d

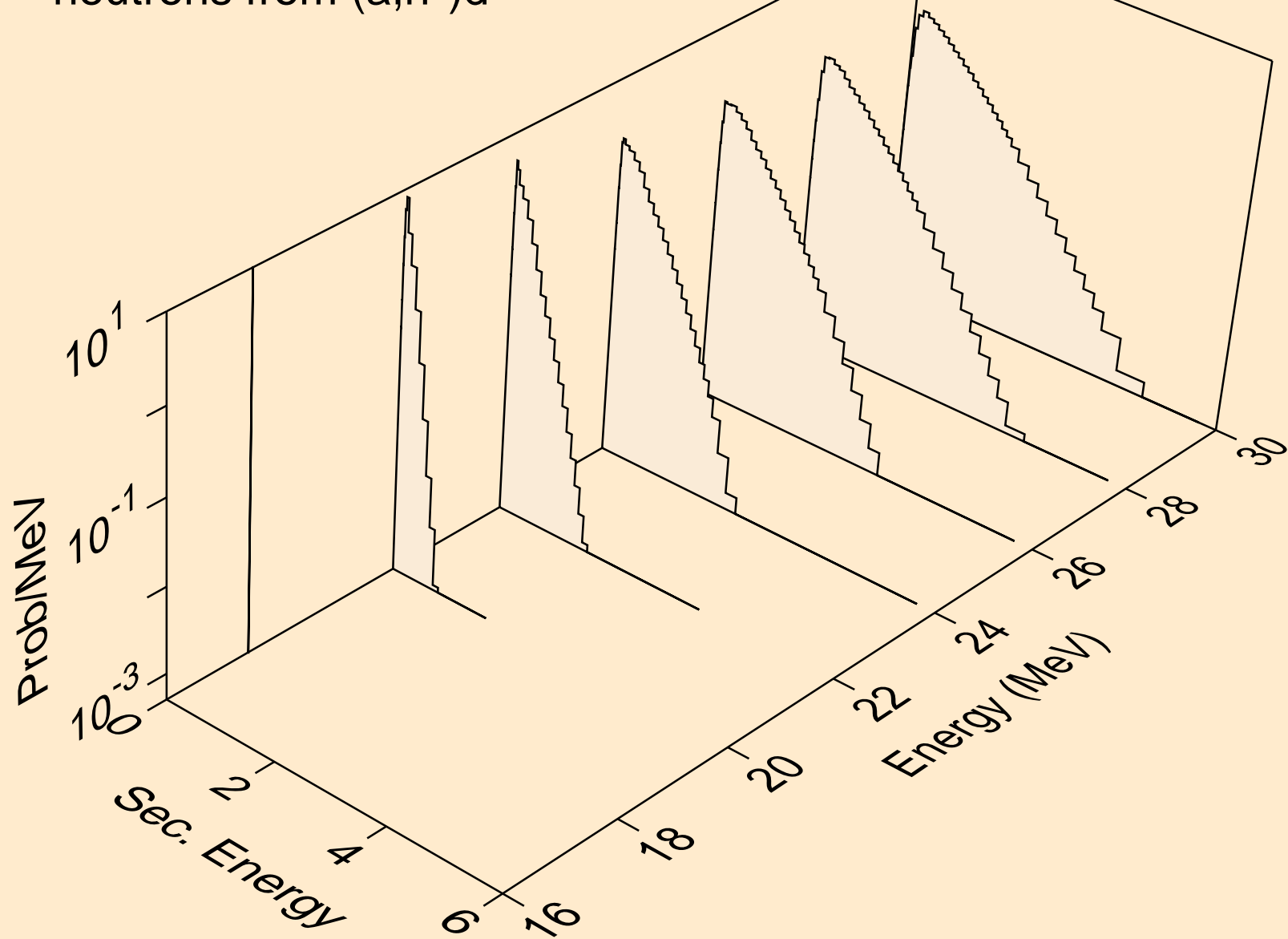

RH106 ALPHA ACER TENDL-2024 LIBRARY; T=0.K
neutrons from (a,n*)t

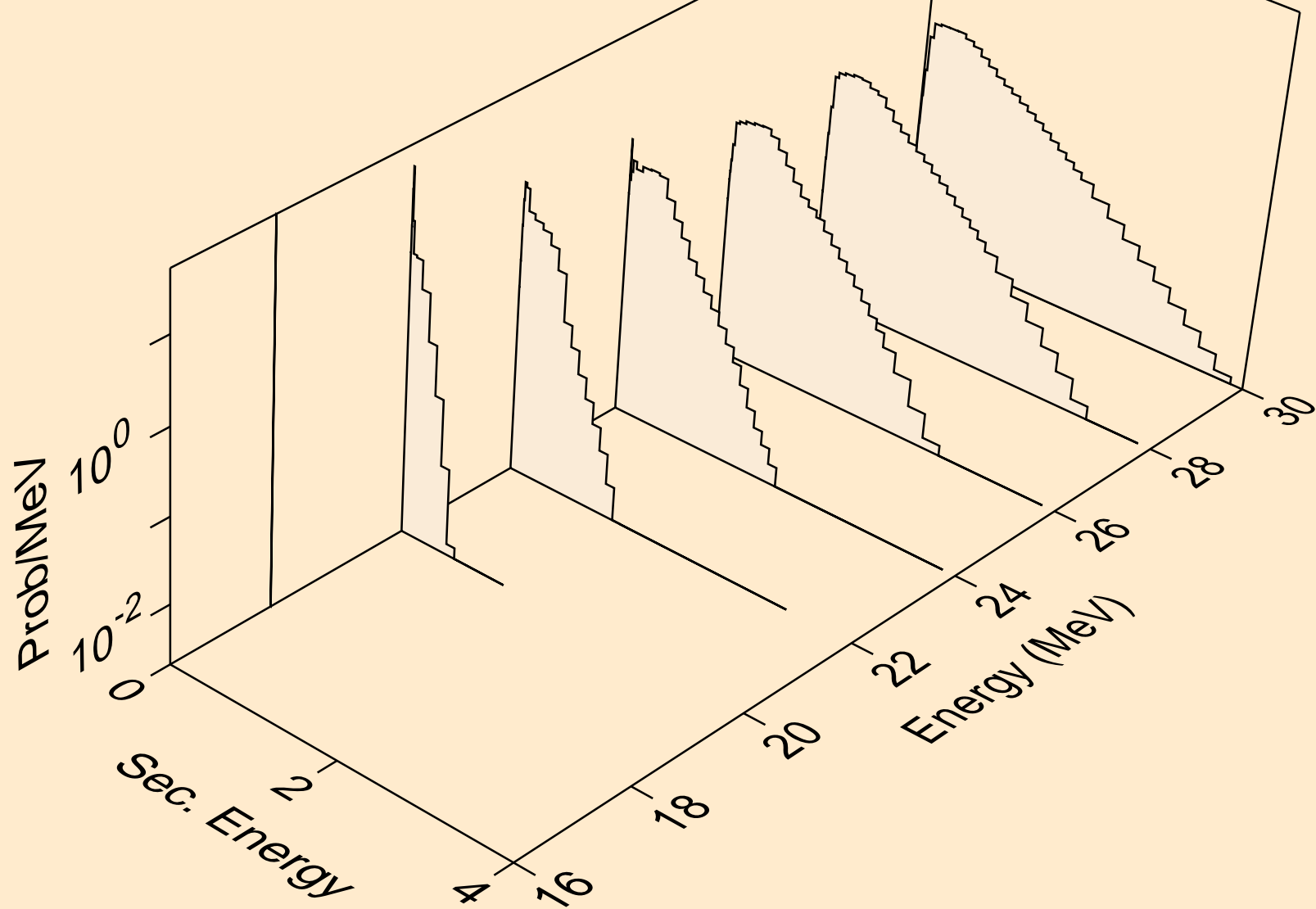

RH106 ALPHA ACER TENDL-2024 LIBRARY; T=0.K
neutrons from (a,n*)he3

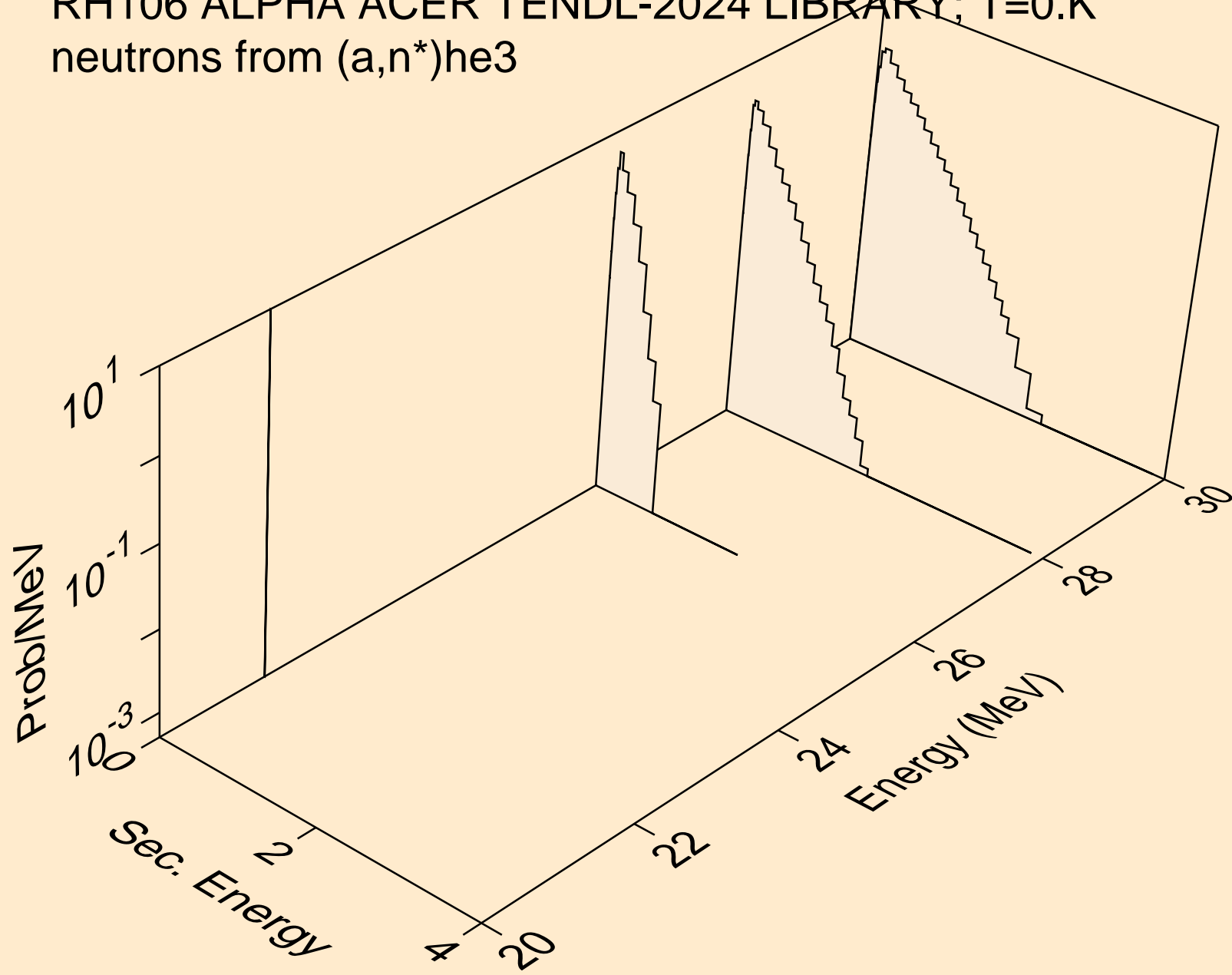

RH106 ALPHA ACER TENDL-2024 LIBRARY; T=0.K
neutrons from (a,2np)

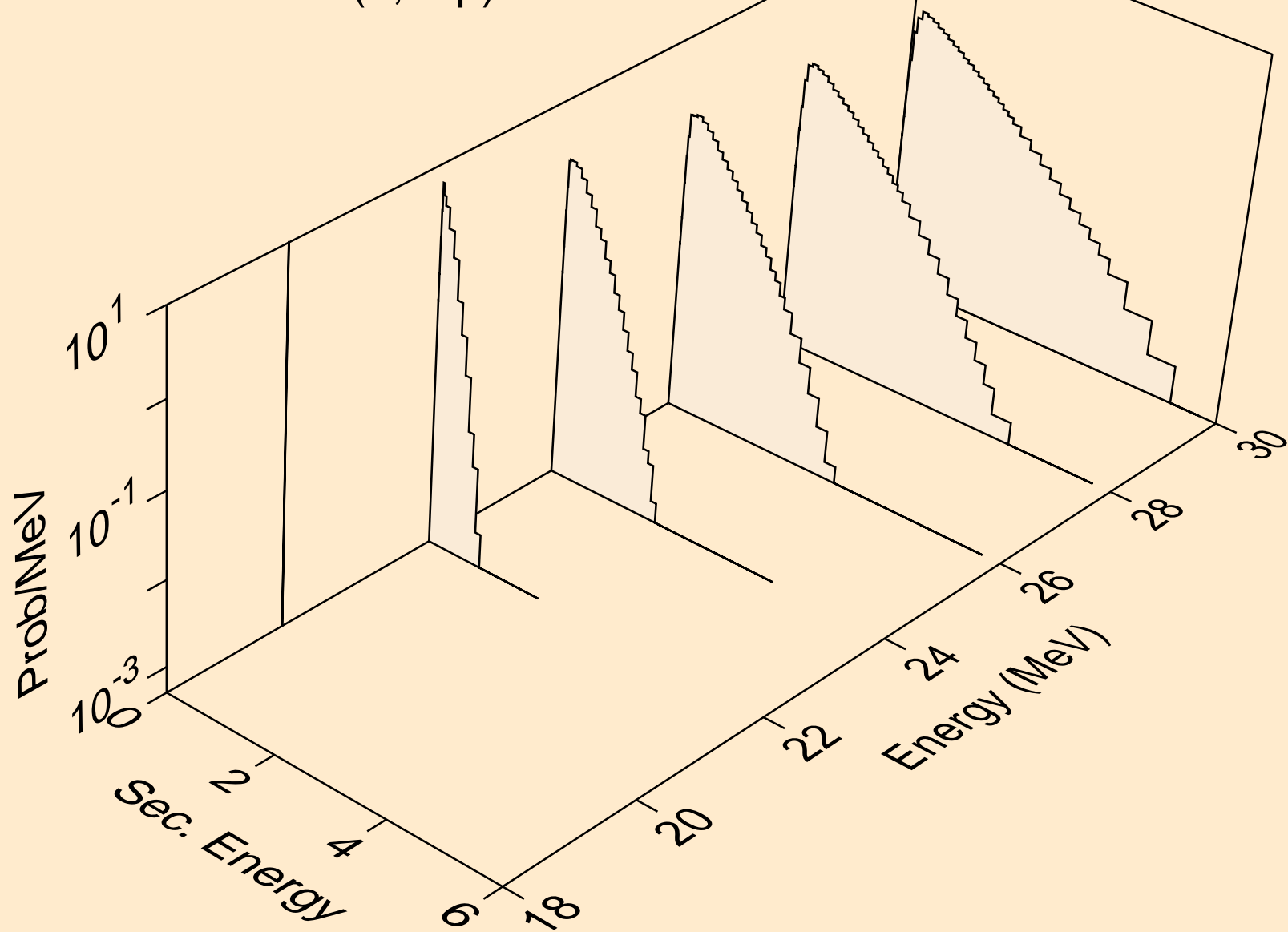

RH106 ALPHA ACER TENDL-2024 LIBRARY; T=0.K
neutrons from (a,3np)

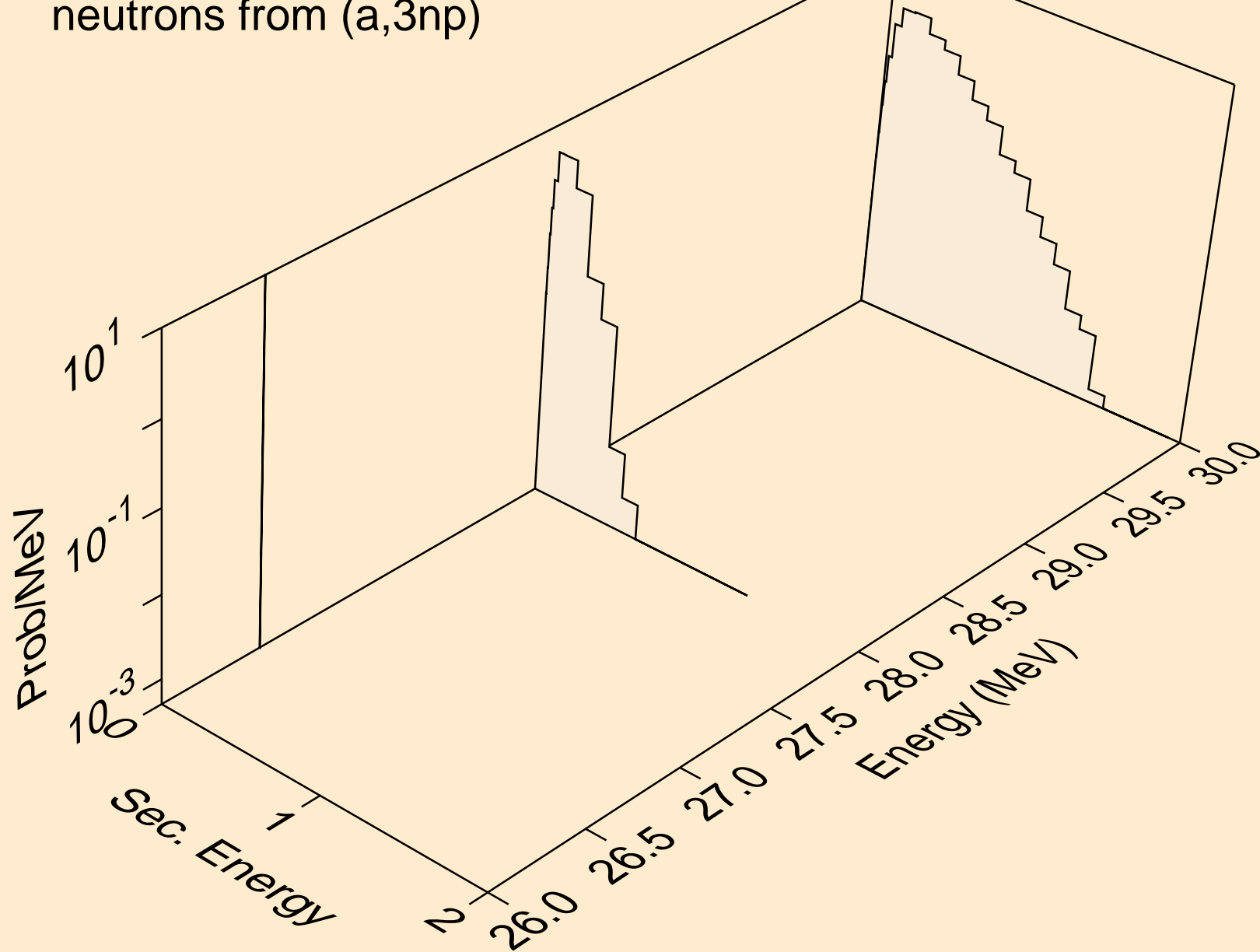

RH106 ALPHA ACER TENDL-2024 LIBRARY; T=0.K
neutrons from (a,n2p)

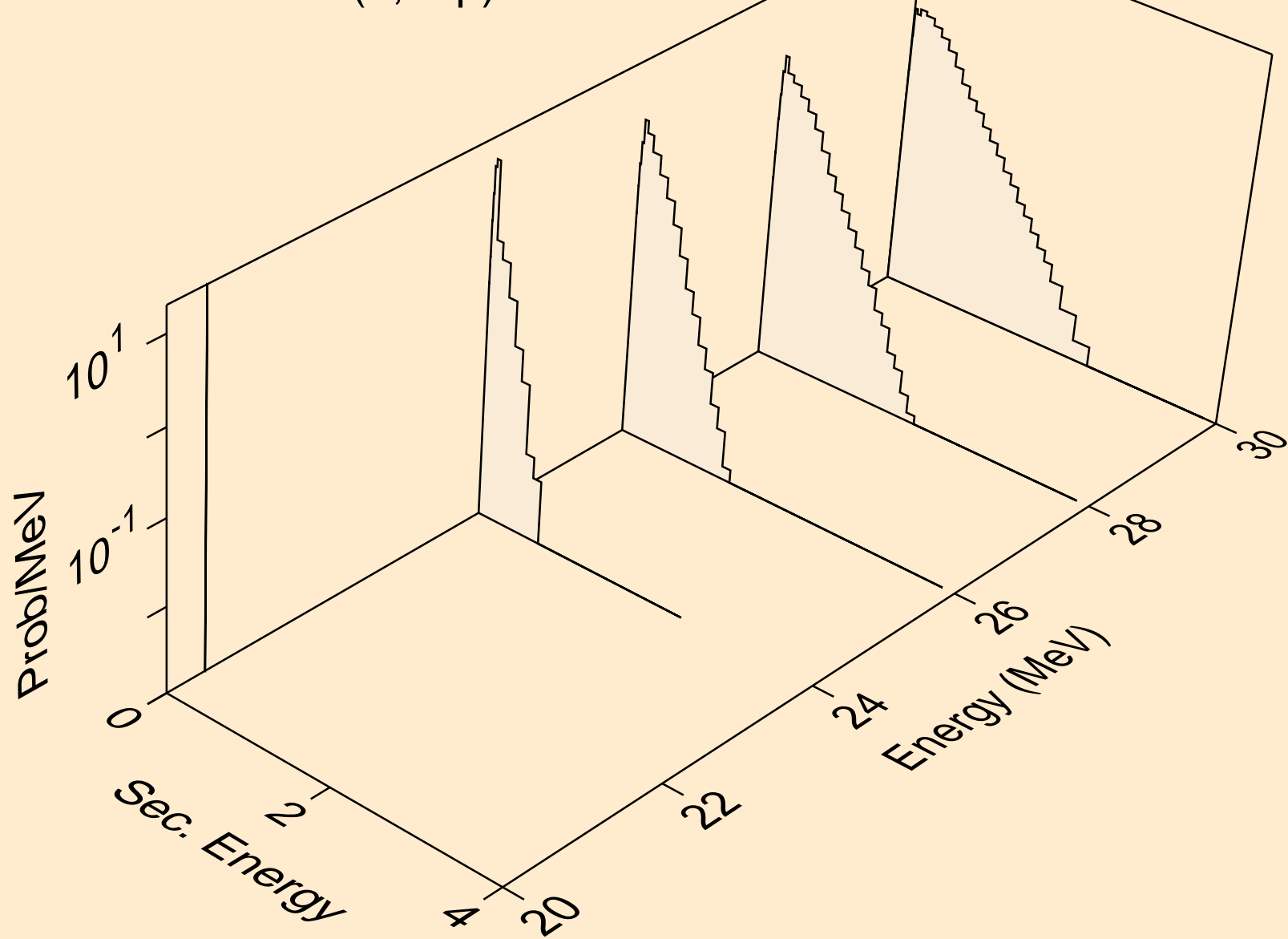

RH106 ALPHA ACER TENDL-2024 LIBRARY; T=0.K
neutrons from (a,npa)

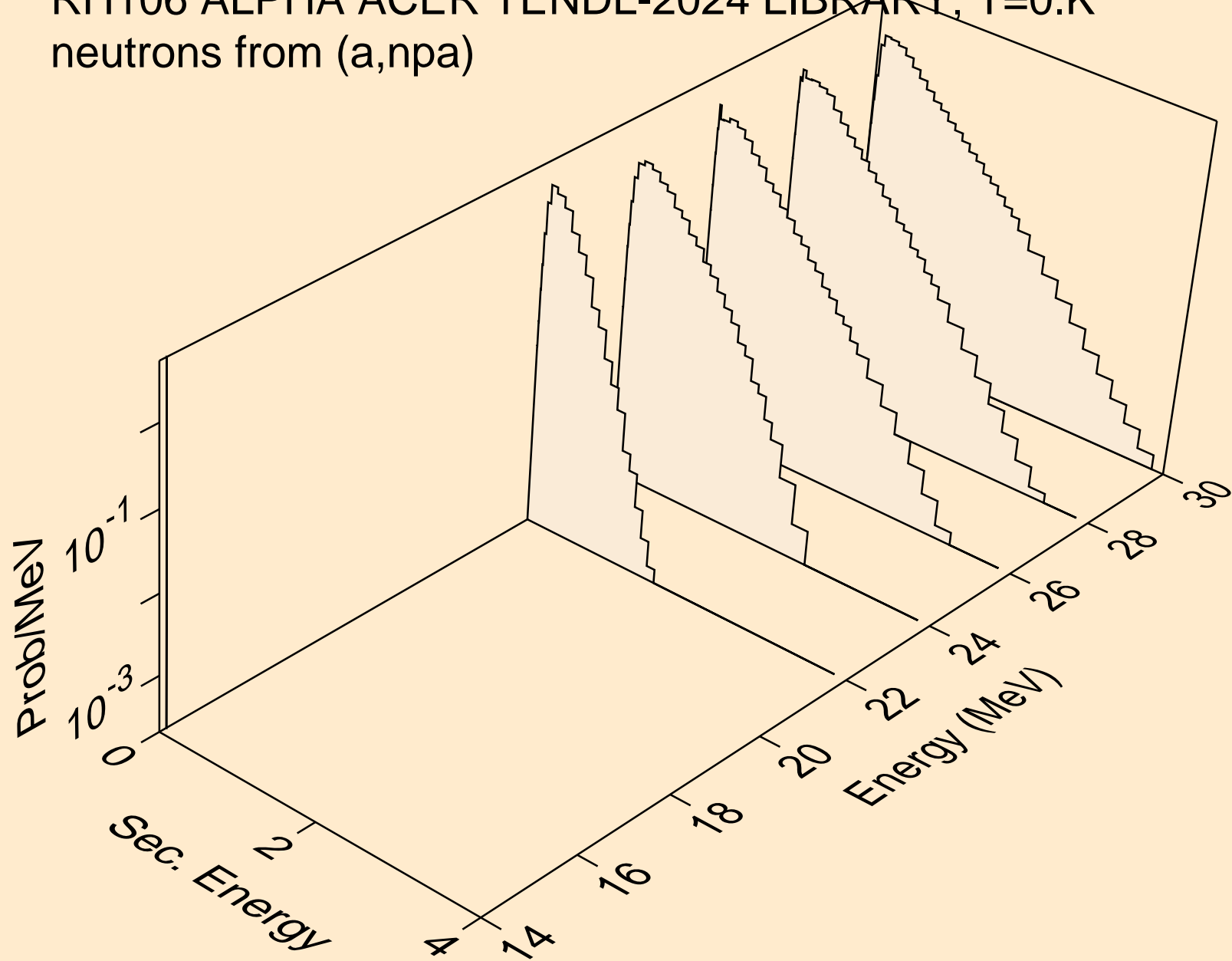

RH106 ALPHA ACER TENDL-2024 LIBRARY; T=0.K
protons from (a,x)

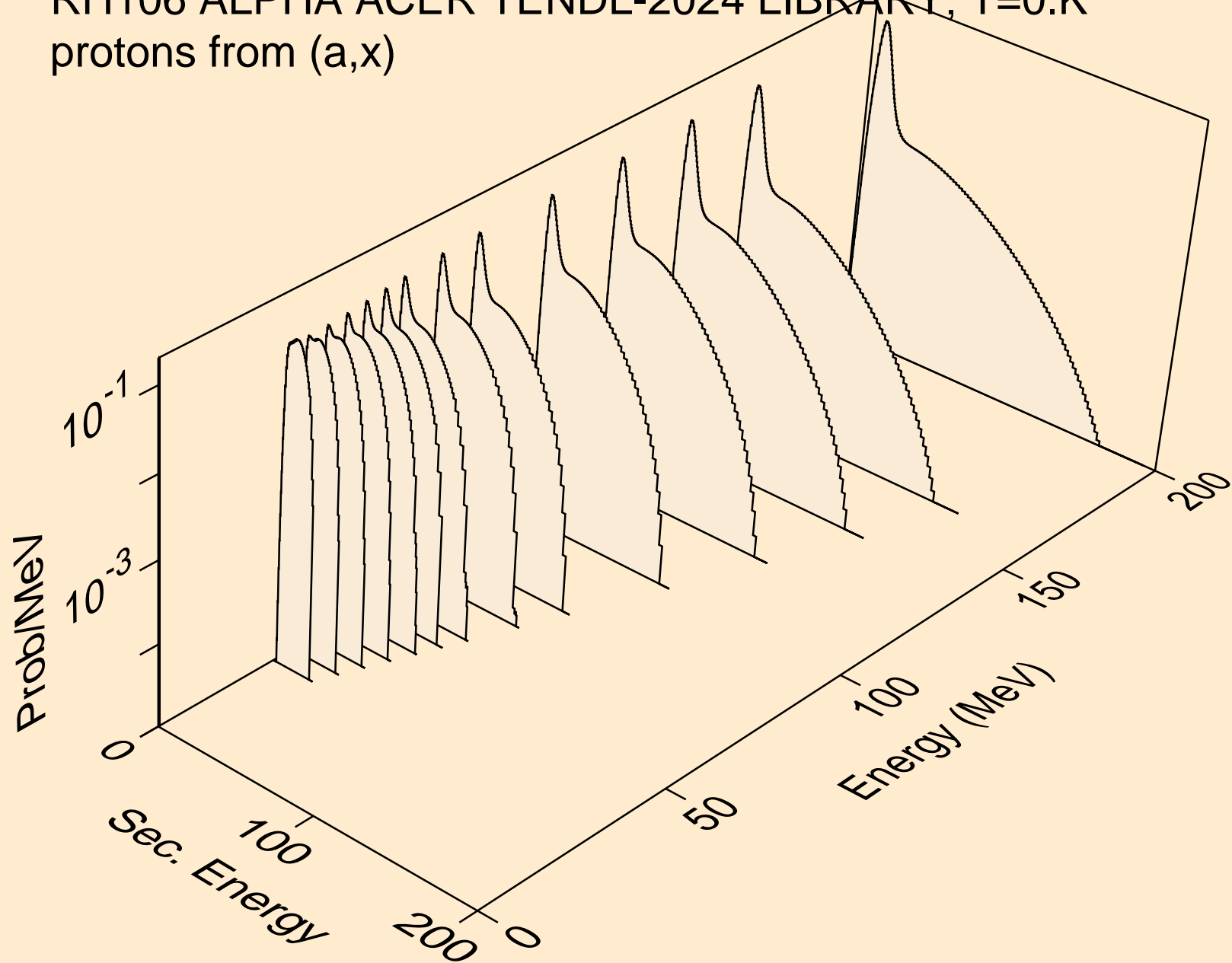

RH106 ALPHA ACER TENDL-2024 LIBRARY; T=0.K
protons from (a,n*)p

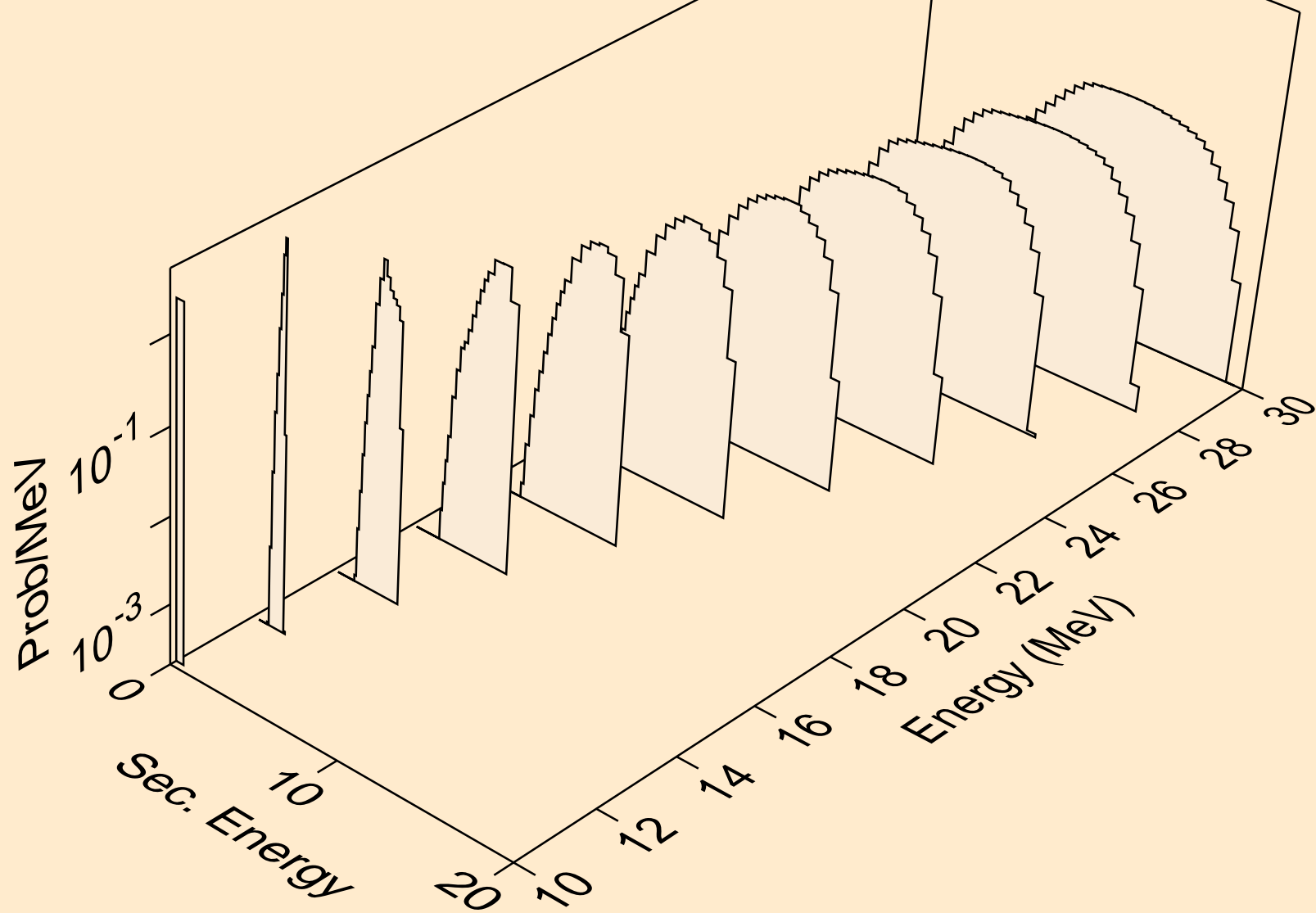

RH106 ALPHA ACER TENDL-2024 LIBRARY; T=0.K
protons from (a,2np)

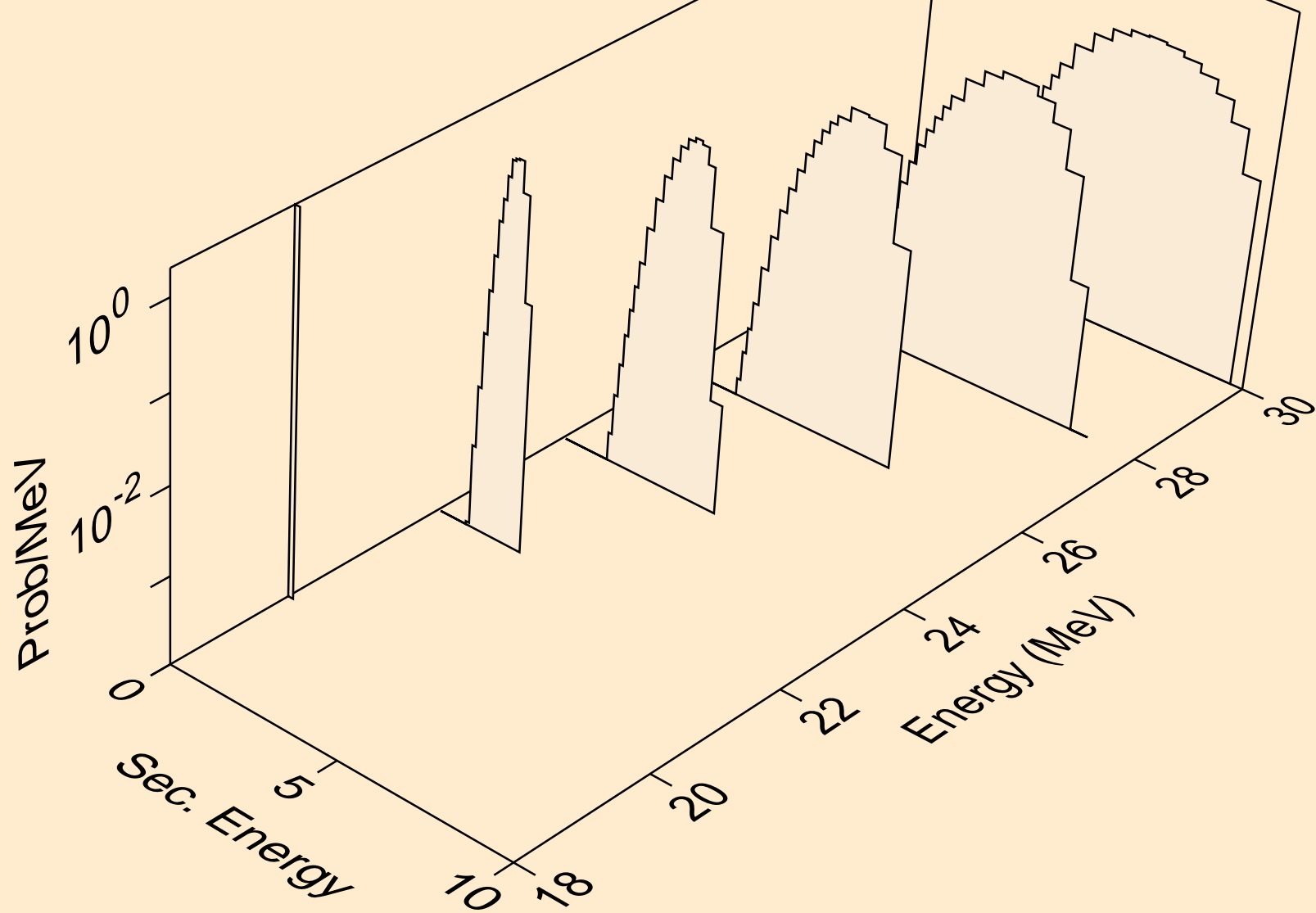

RH106 ALPHA ACER TENDL-2024 LIBRARY; T=0.K
protons from (a,3np)

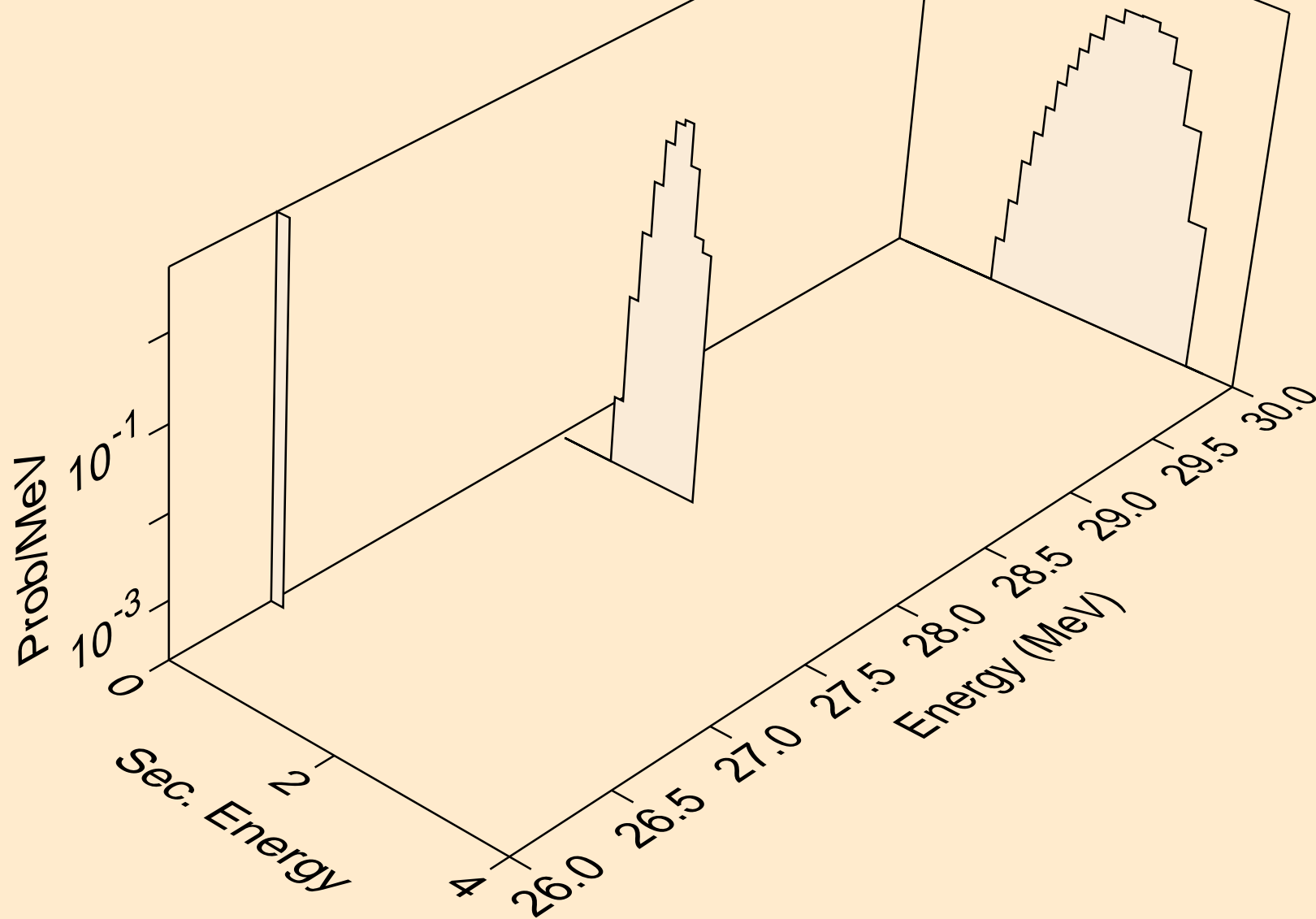

RH106 ALPHA ACER TENDL-2024 LIBRARY; T=0.K
protons from (a,n2p)

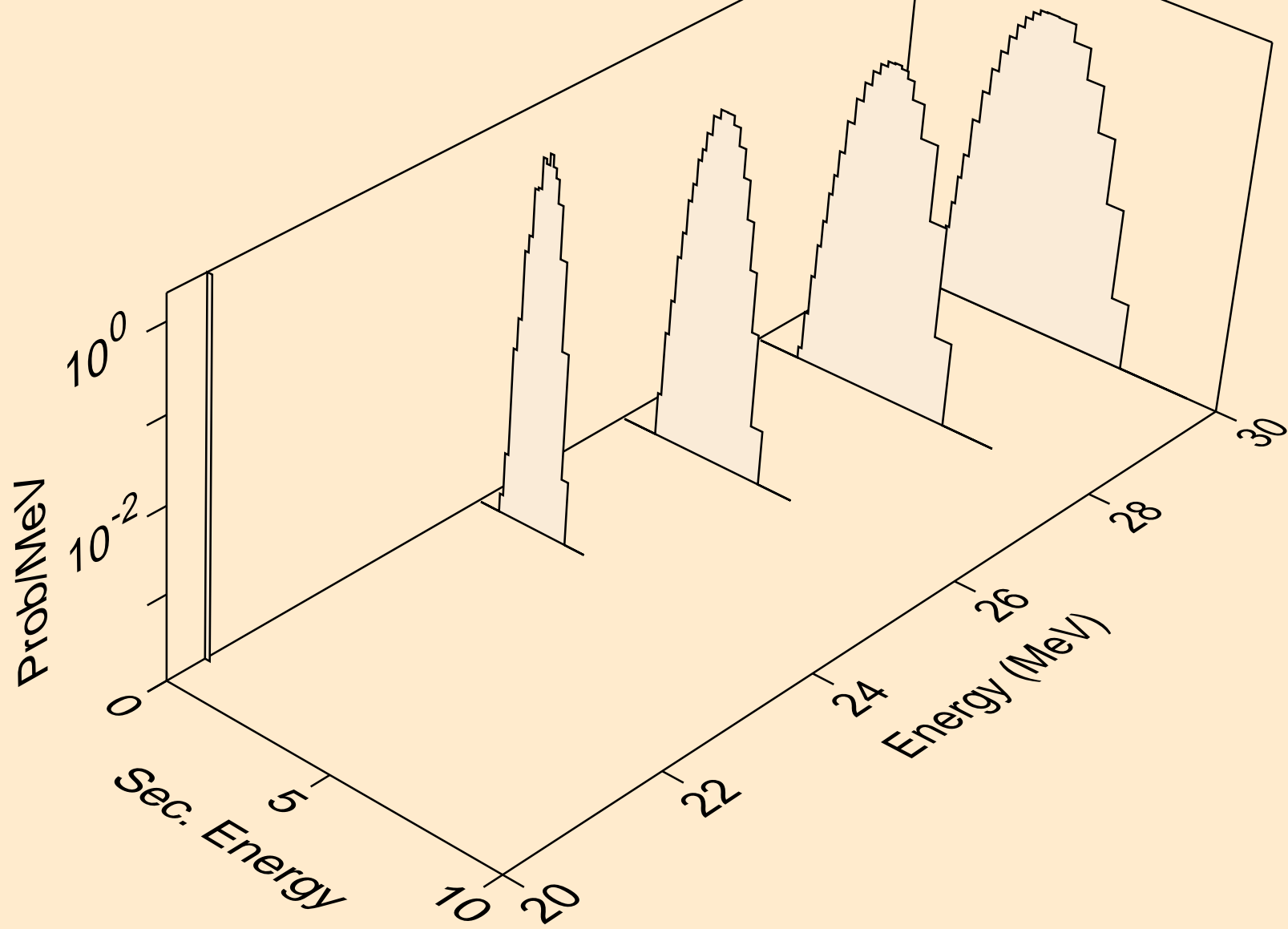

RH106 ALPHA ACER TENDL-2024 LIBRARY; T=0.K
protons from (a,npa)

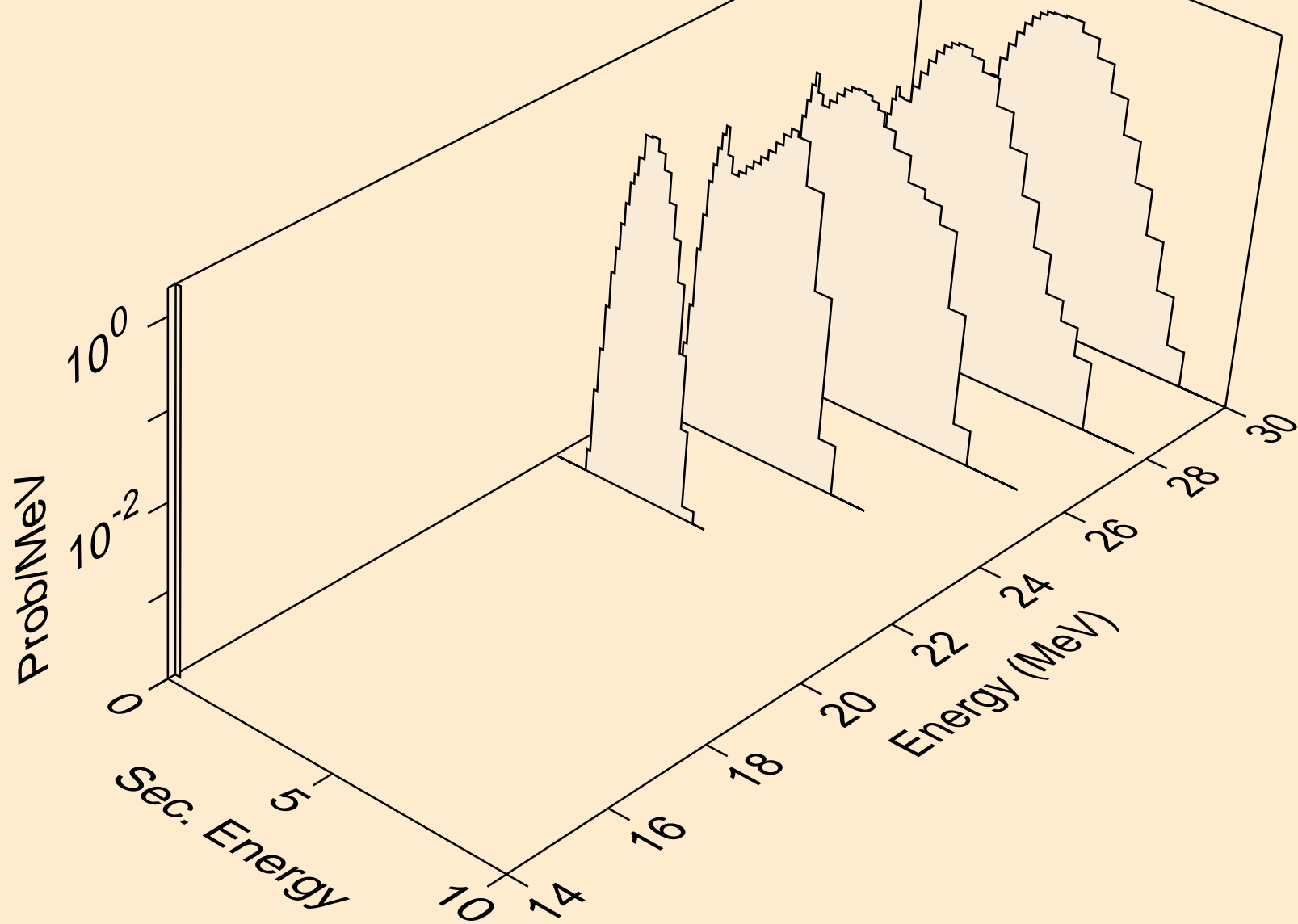

RH106 ALPHA ACER TENDL-2024 LIBRARY; T=0.K
protons from (a,p)

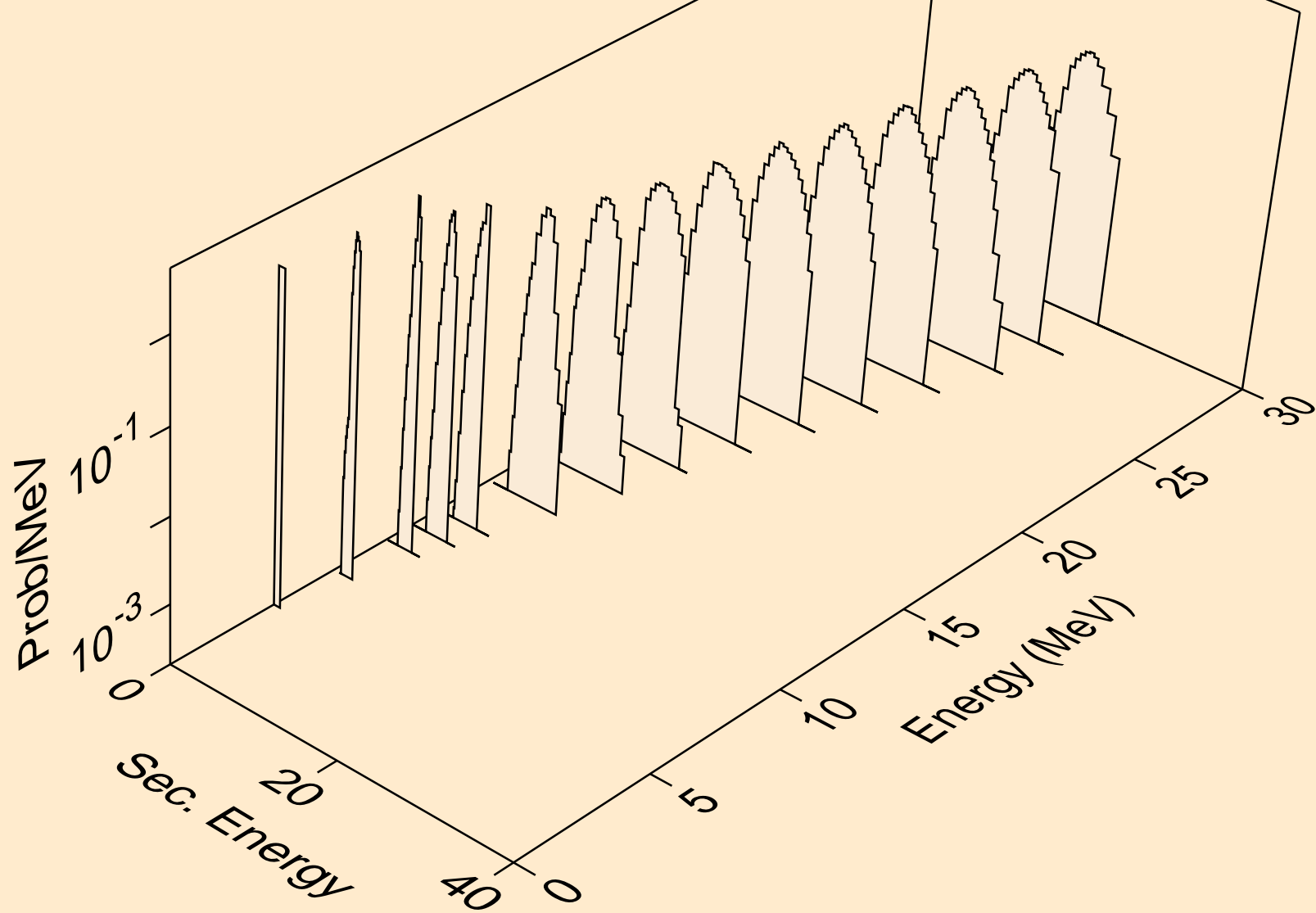

RH106 ALPHA ACER TENDL-2024 LIBRARY; T=0.K
protons from (a,2p)

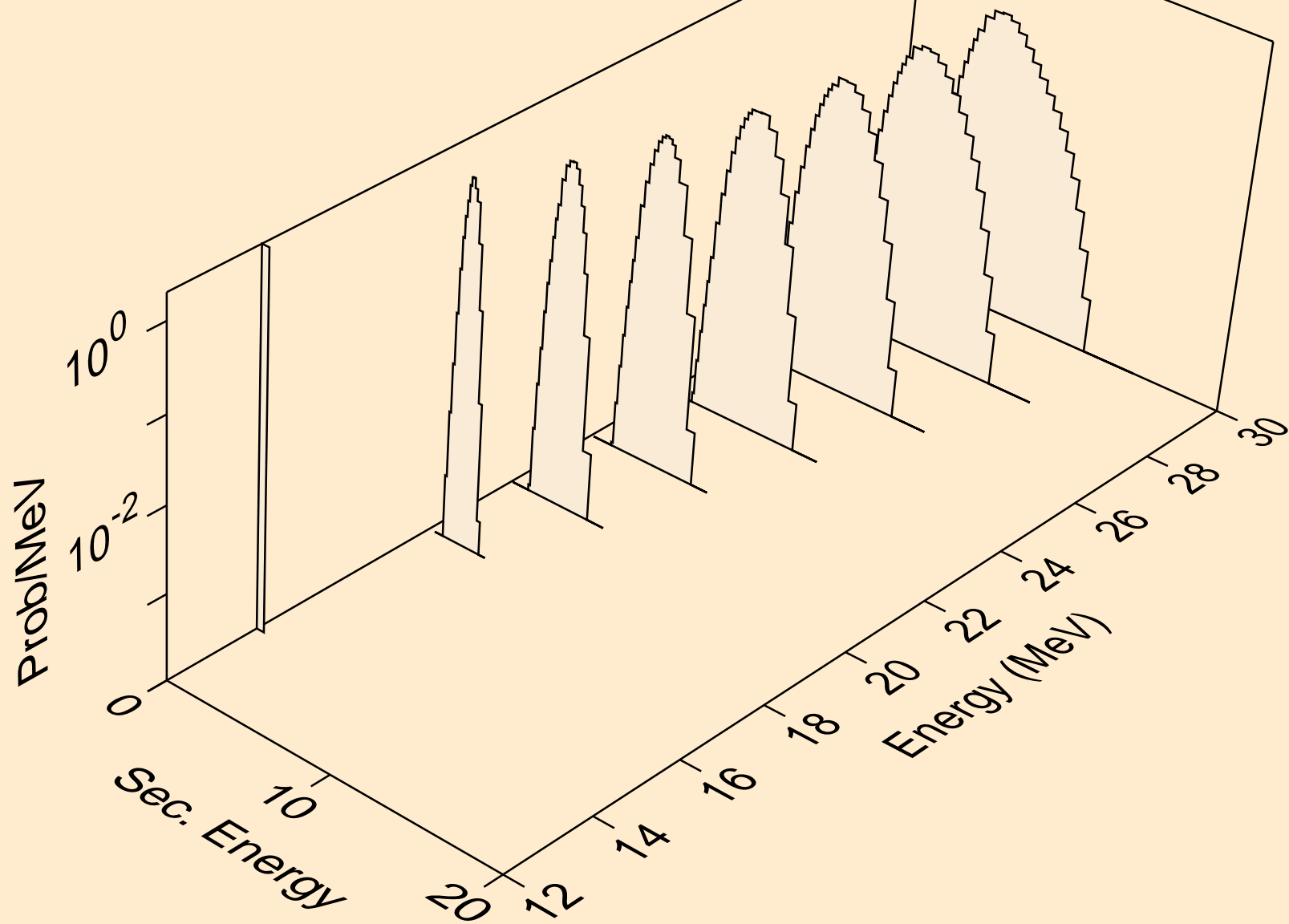

RH106 ALPHA ACER TENDL-2024 LIBRARY; T=0.K
protons from (a,pa)

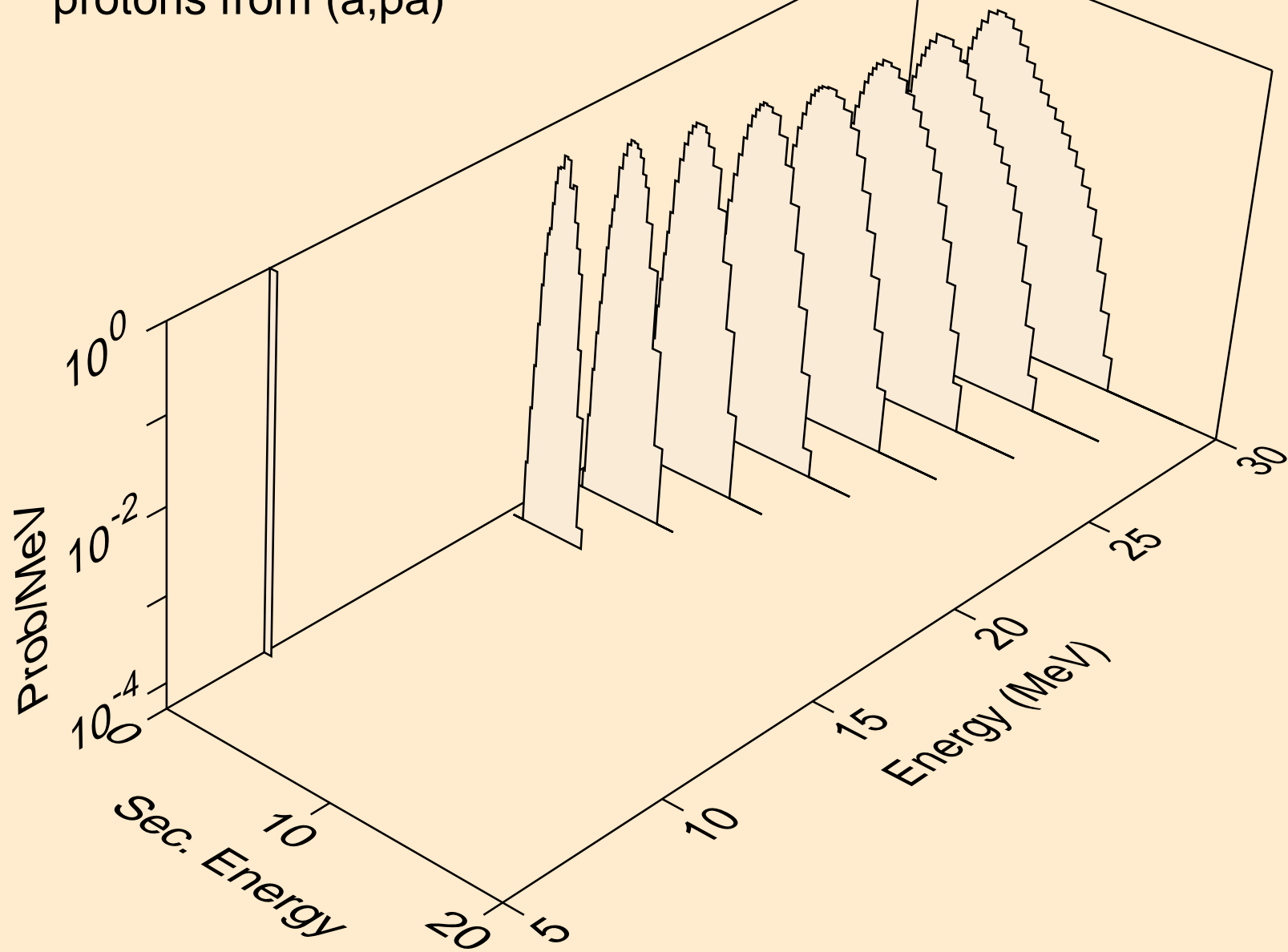

RH106 ALPHA ACER TENDL-2024 LIBRARY; T=0.K
protons from (a,pd)

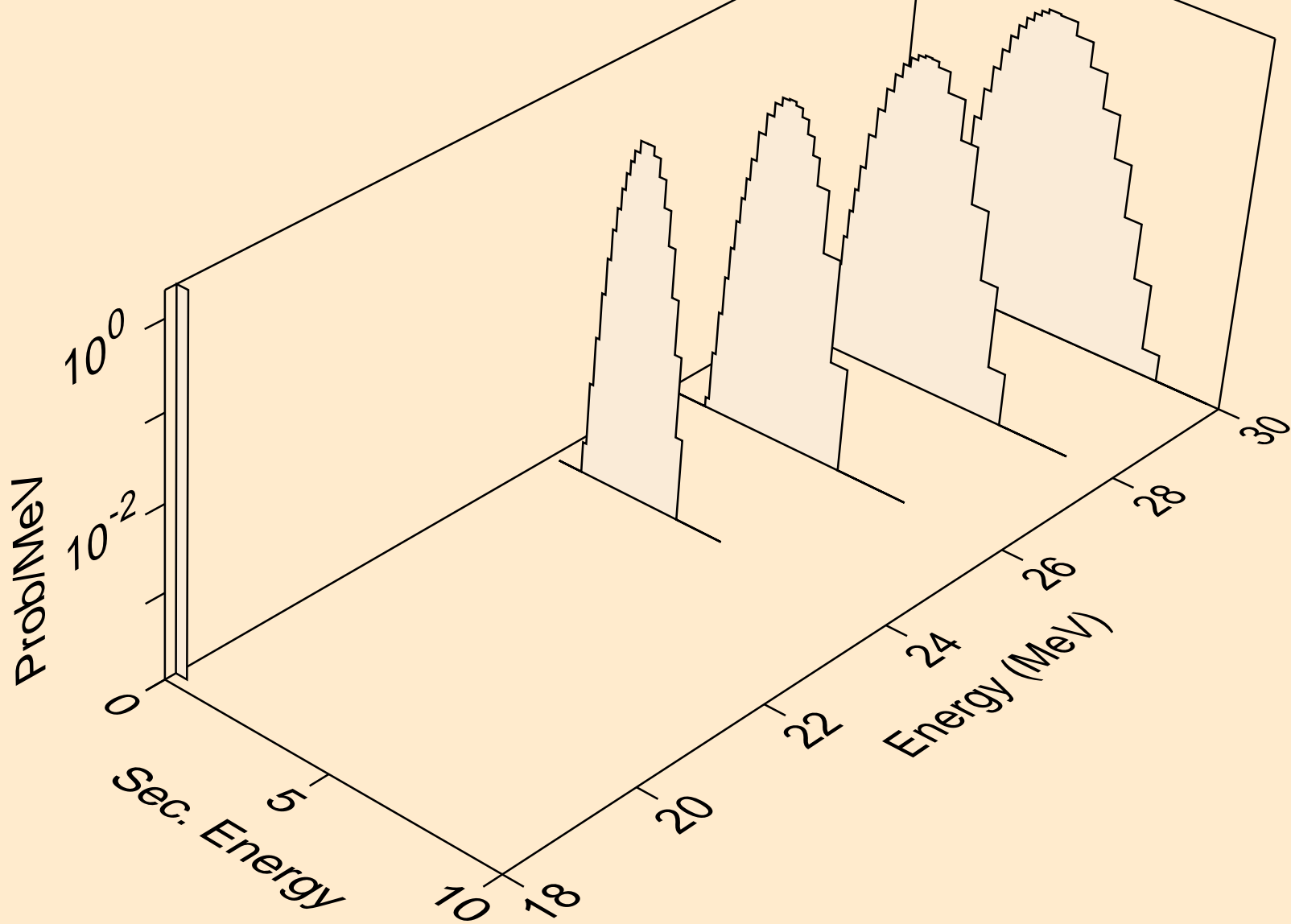

RH106 ALPHA ACER TENDL-2024 LIBRARY; T=0.K
deuterons from (a,x)

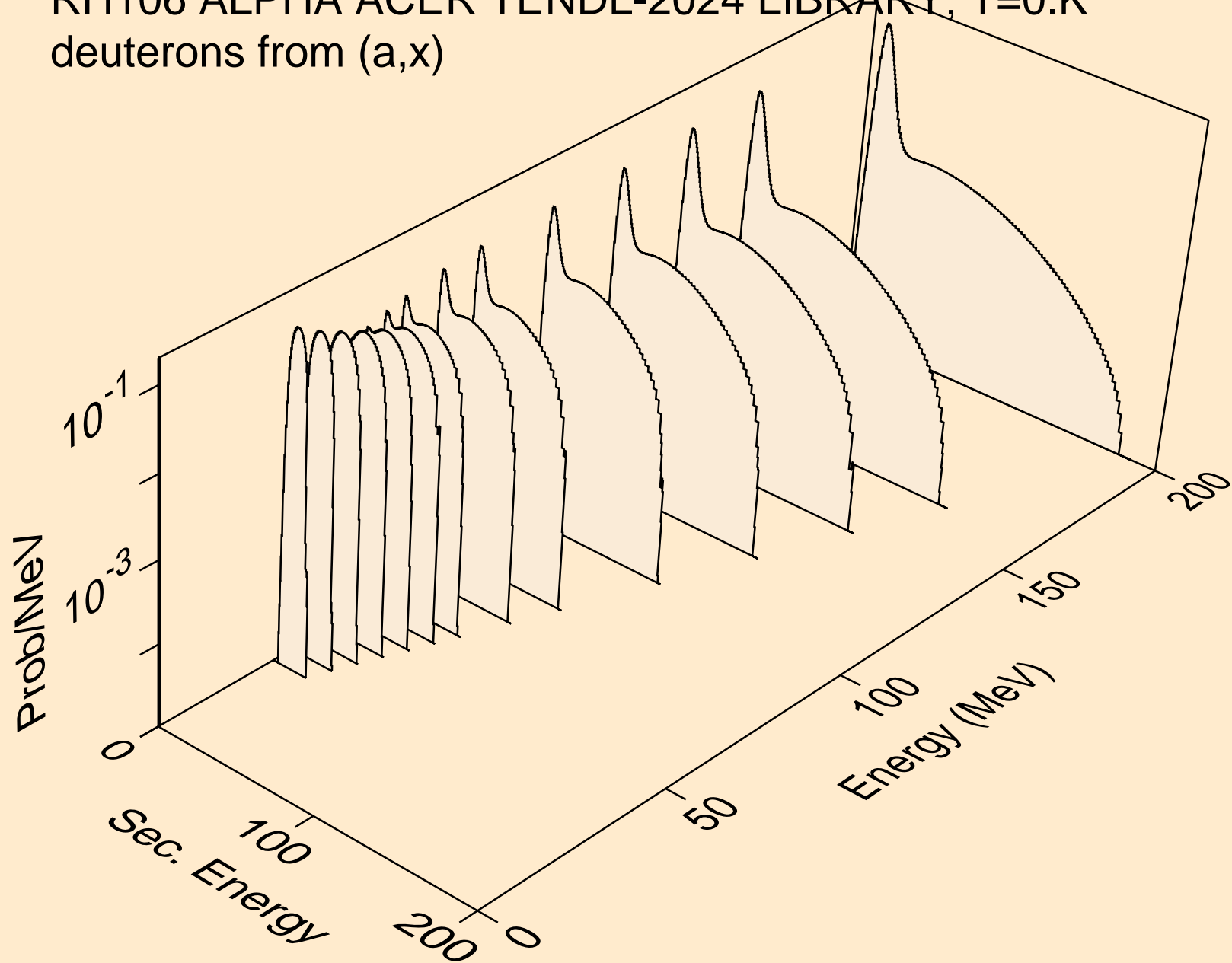

RH106 ALPHA ACER TENDL-2024 LIBRARY; T=0.K
deuterons from (a,2nd)

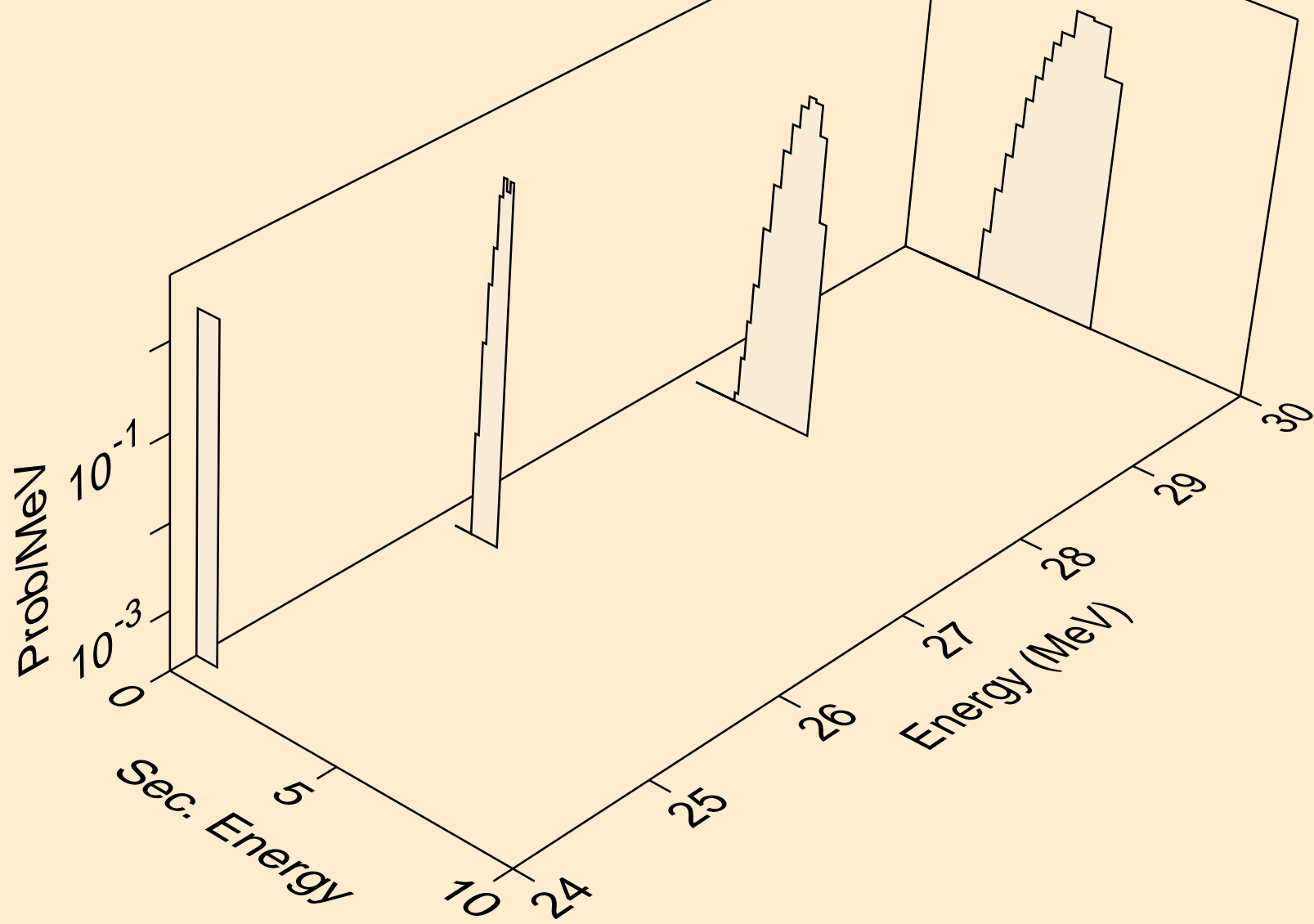

RH106 ALPHA ACER TENDL-2024 LIBRARY; T=0.K
deuterons from (a,n*)d

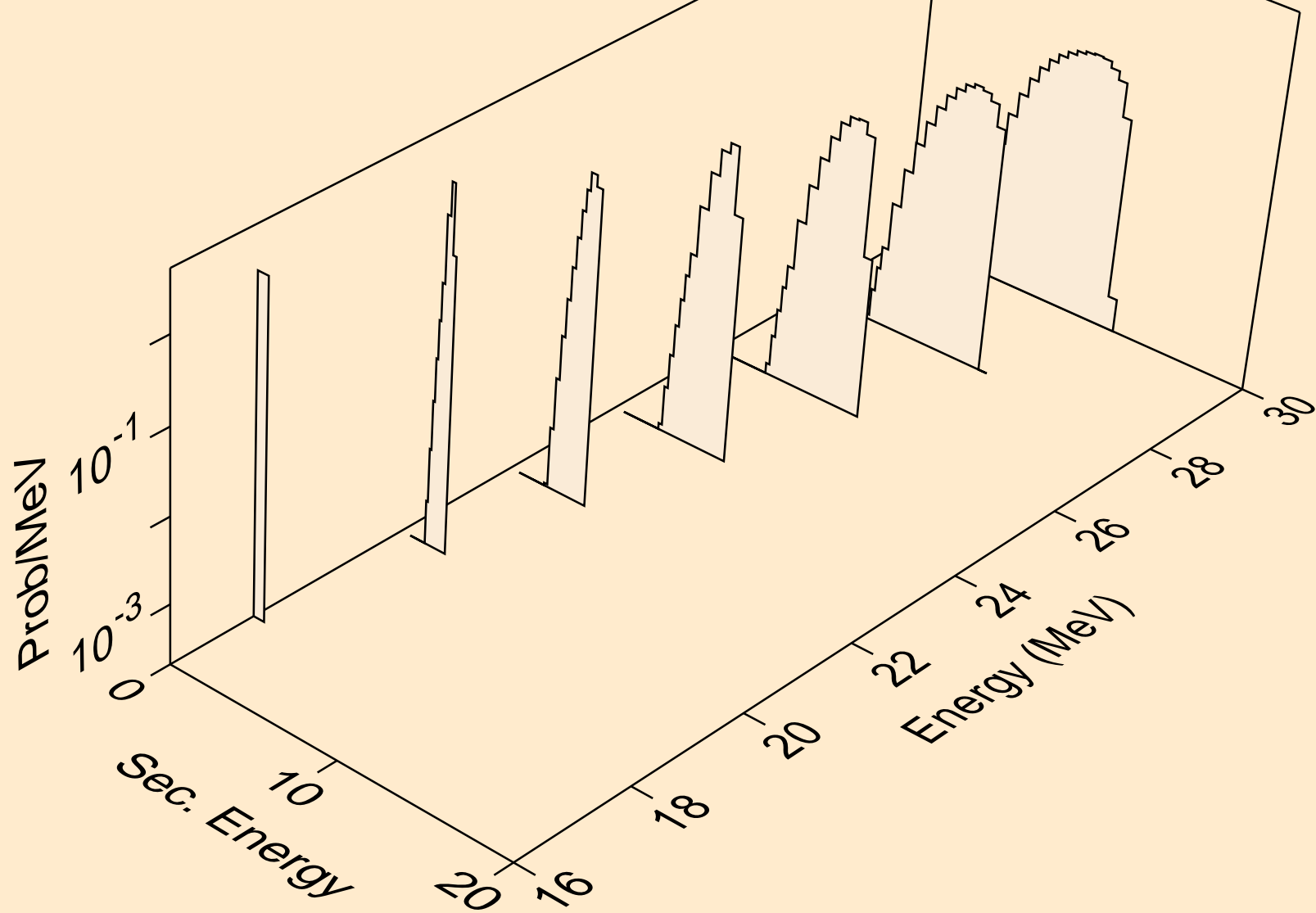

RH106 ALPHA ACER TENDL-2024 LIBRARY; T=0.K
deuterons from (a,d)

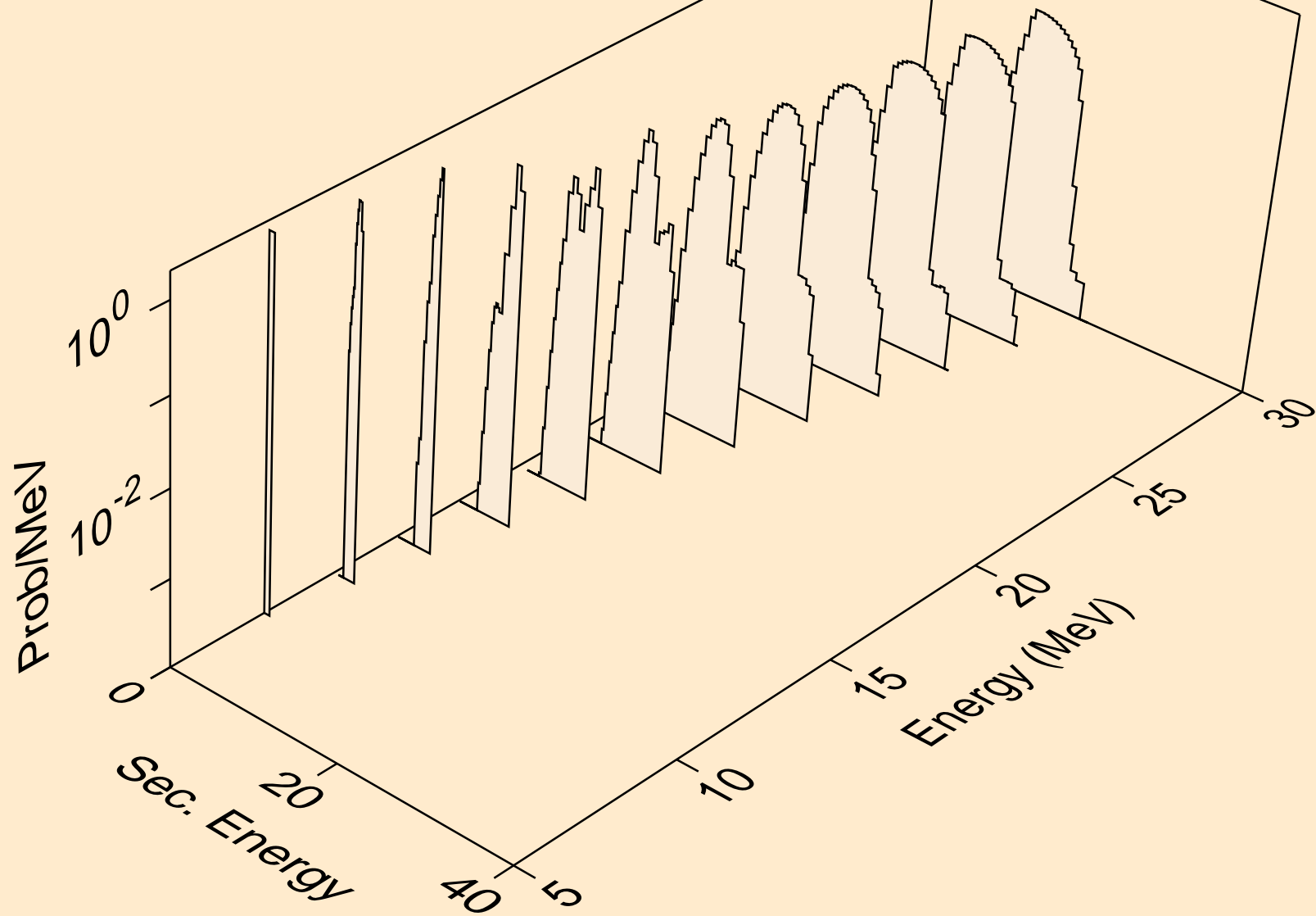

RH106 ALPHA ACER TENDL-2024 LIBRARY; T=0.K
deuterons from (a,pd)

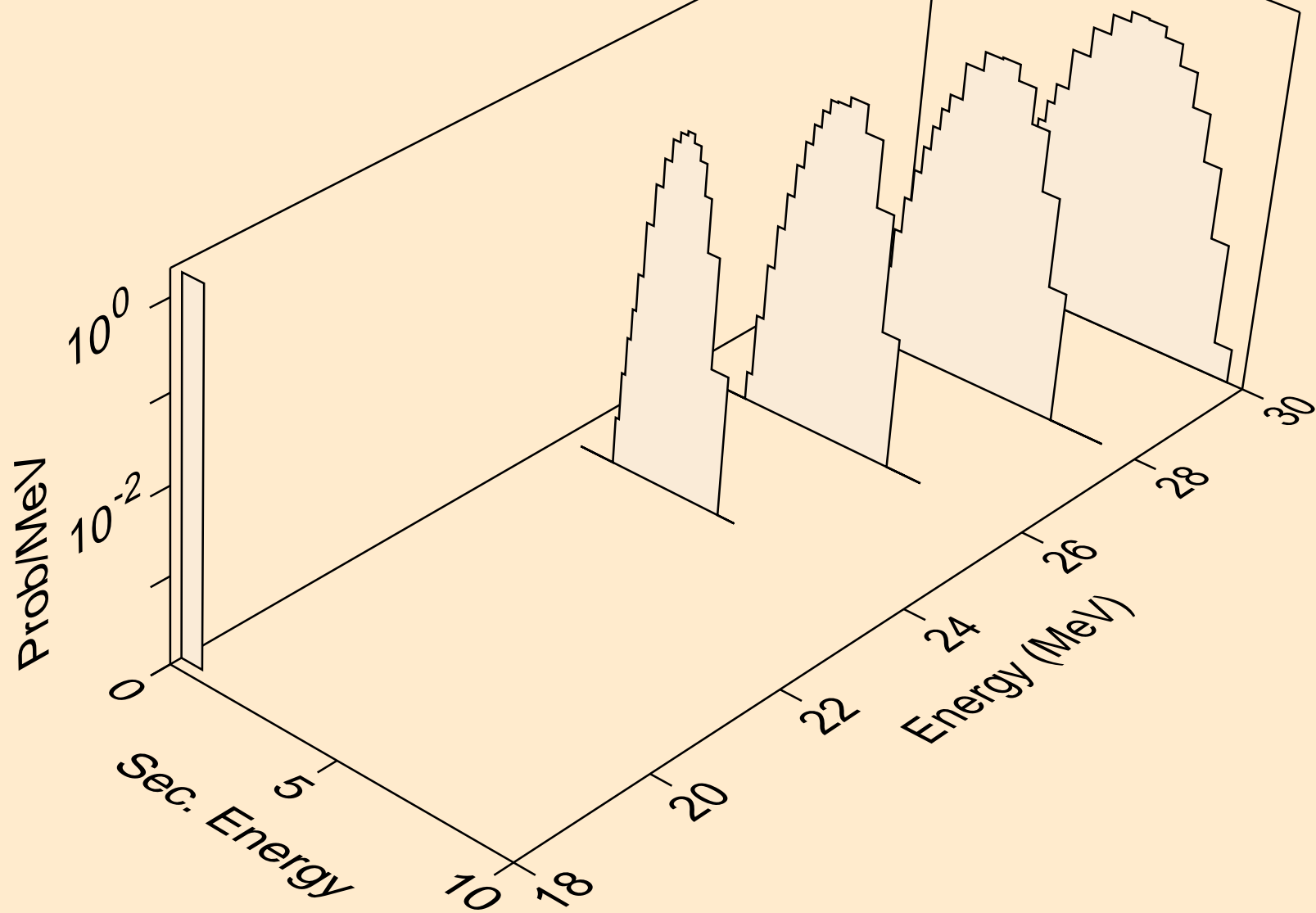

RH106 ALPHA ACER TENDL-2024 LIBRARY; T=0.K
deuterons from (a,da)

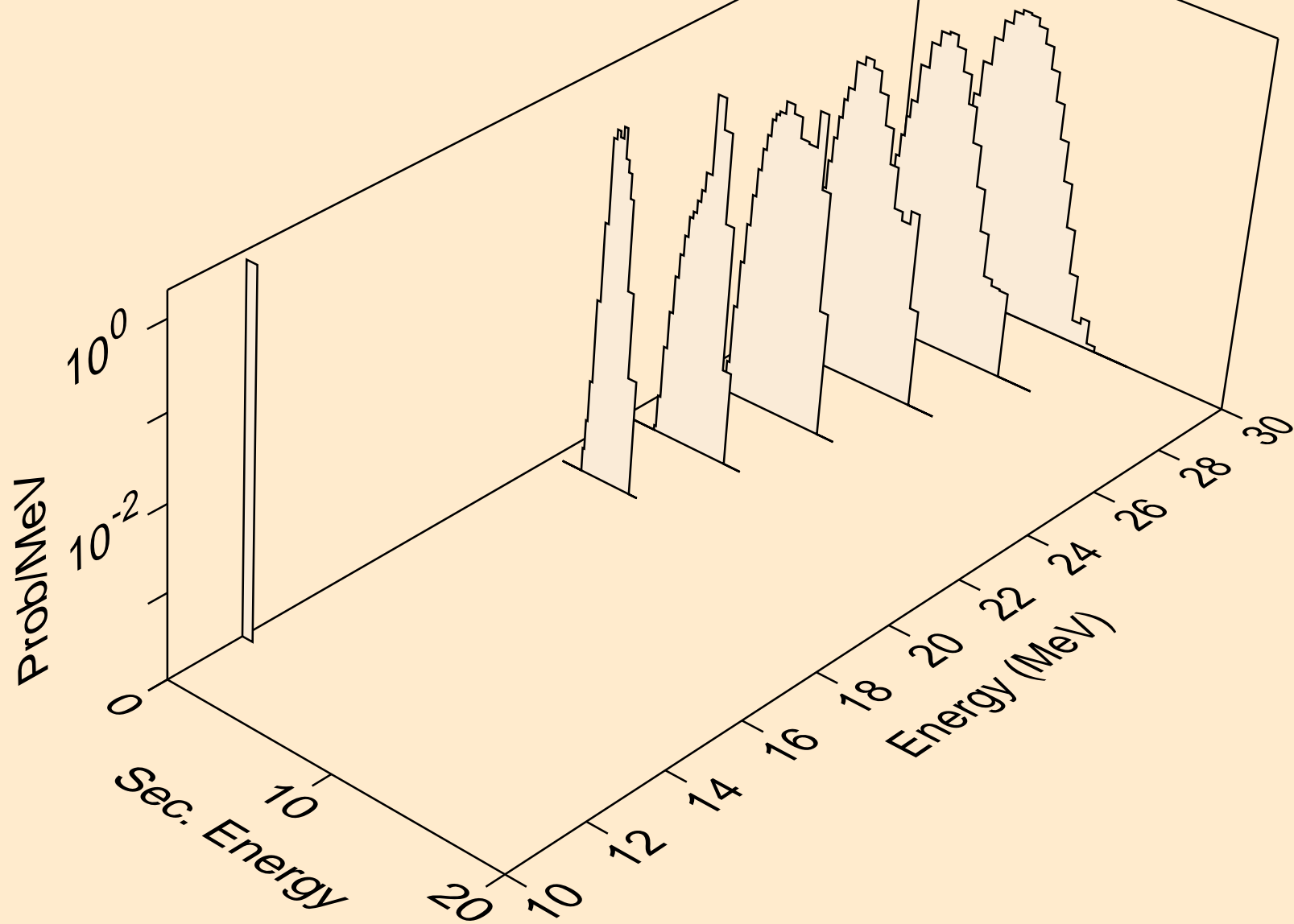

RH106 ALPHA ACER TENDL-2024 LIBRARY; T=0.K
tritons from (a,x)

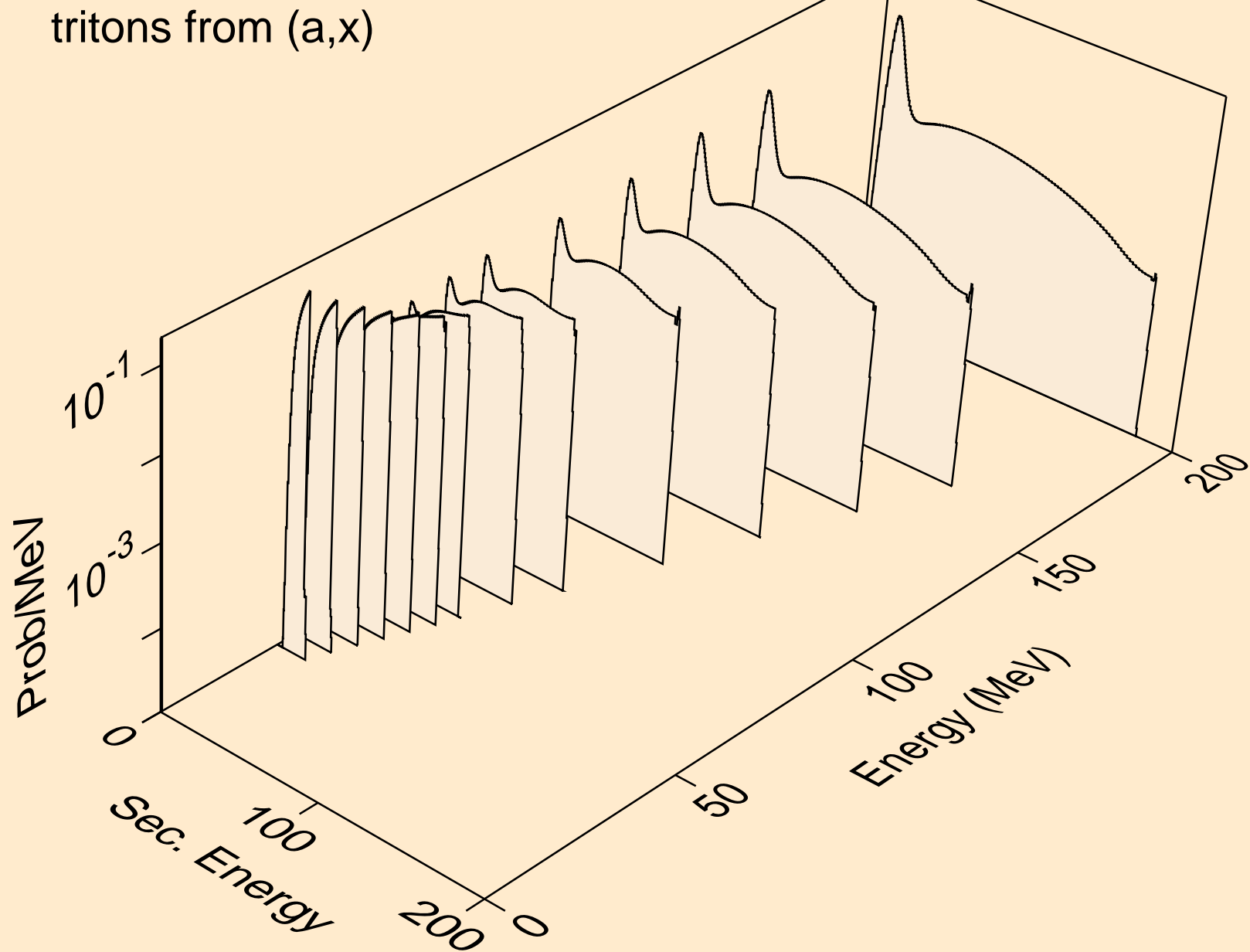

RH106 ALPHA ACER TENDL-2024 LIBRARY; T=0.K
tritons from (a,n*)t

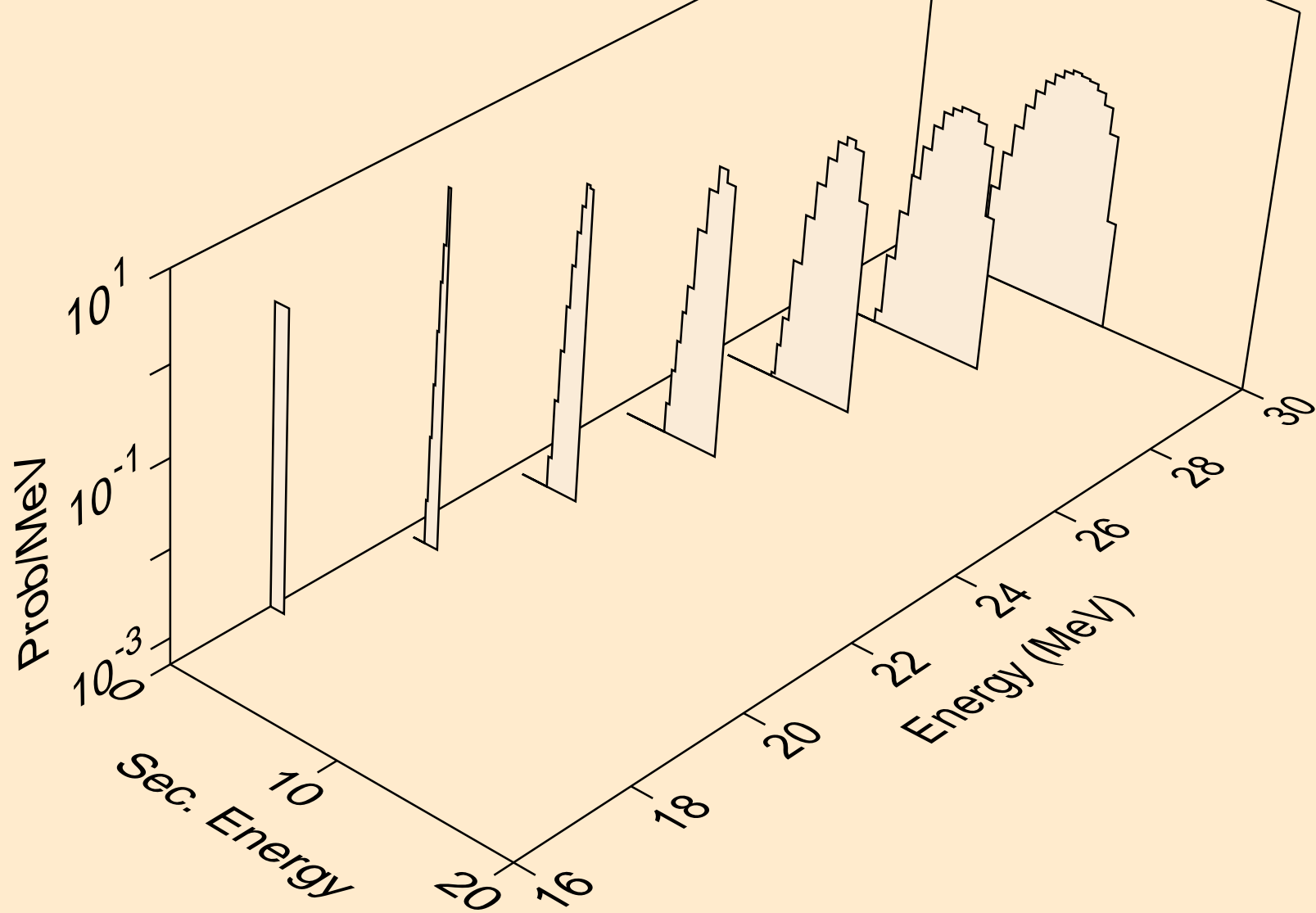

RH106 ALPHA ACER TENDL-2024 LIBRARY; T=0.K
tritons from (a,t)

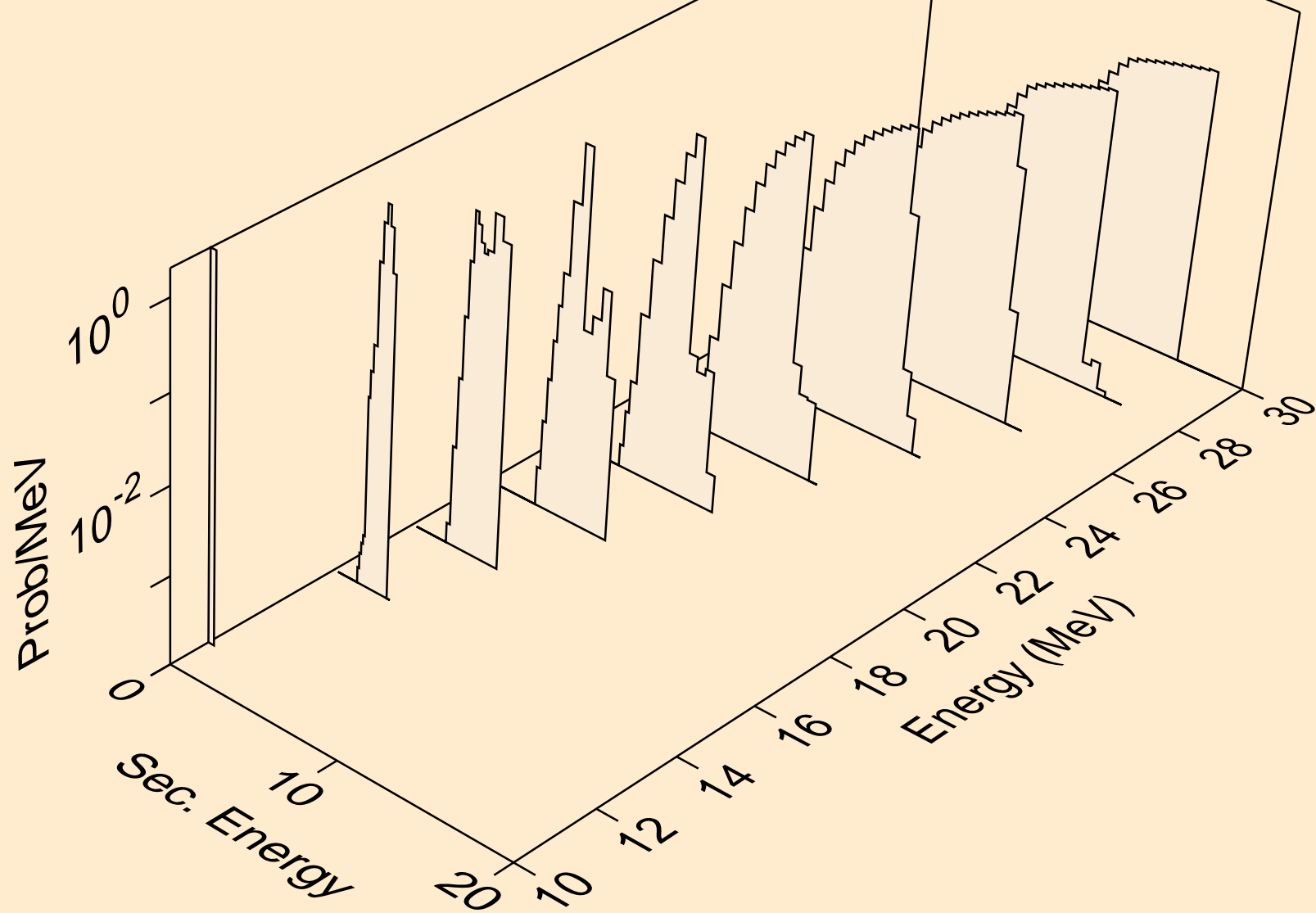

RH106 ALPHA ACER TENDL-2024 LIBRARY; T=0.K
he3s from (a,x)

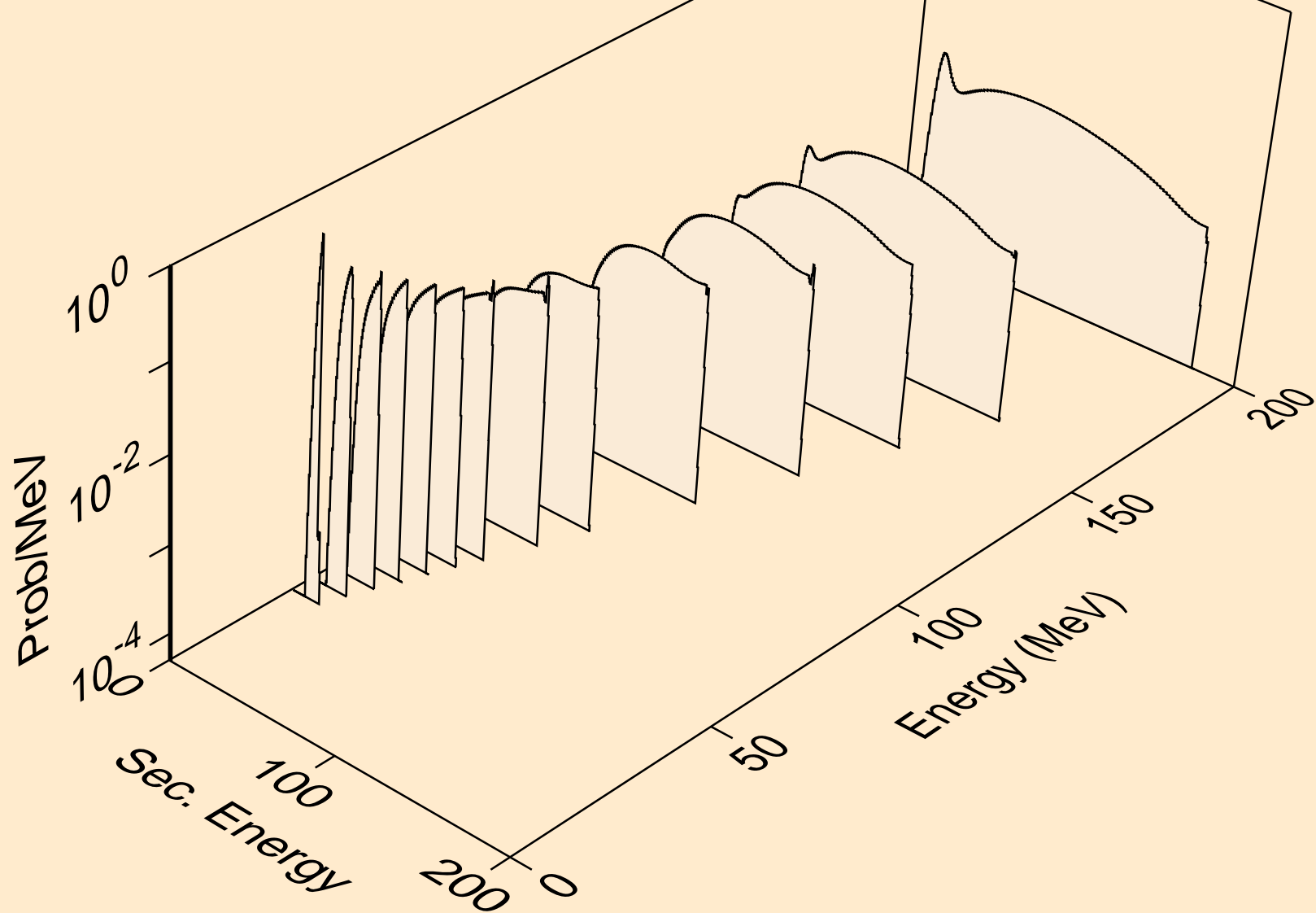

RH106 ALPHA ACER TENDL-2024 LIBRARY; T=0.K
he3s from (a,n*)he3

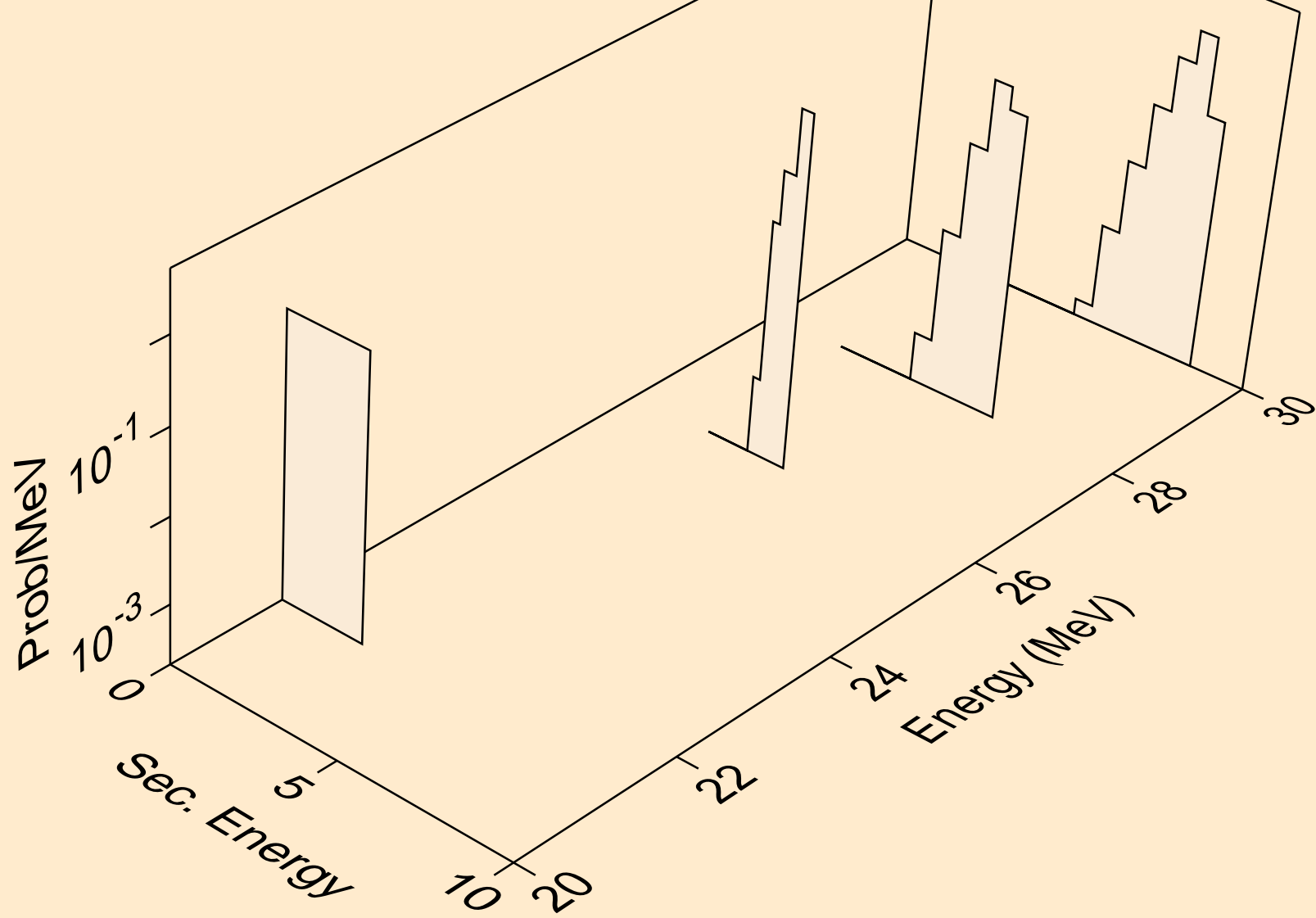

RH106 ALPHA ACER TENDL-2024 LIBRARY; T=0.K
he3s from (a,he3)

