

# AC224 DEUTERON ACER TENDL-2024 LIBRARY; T=0.K

## Principal cross sections

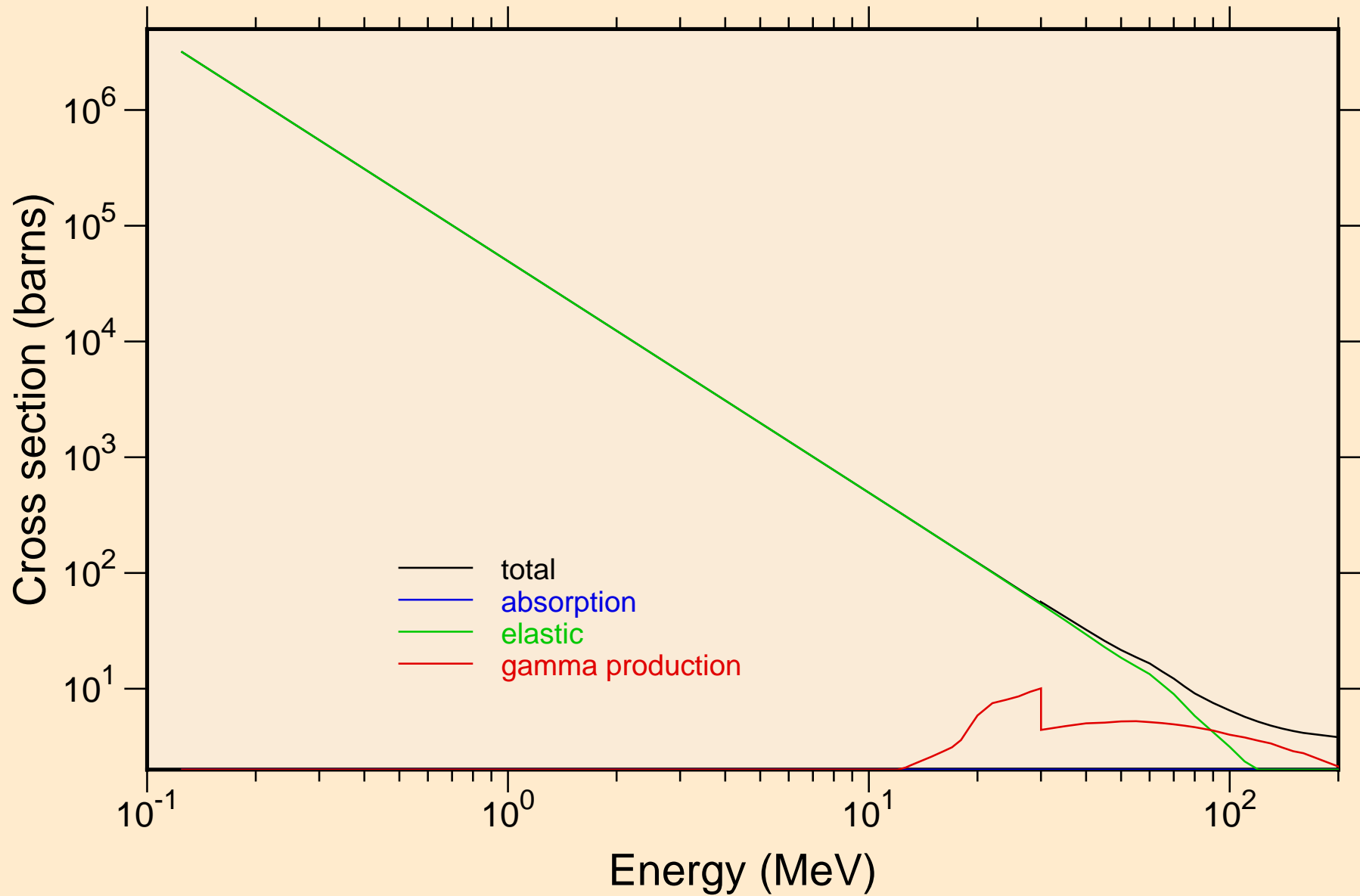

AC224 DEUTERON ACER TENDL-2024 LIBRARY; T=0.K  
Heating

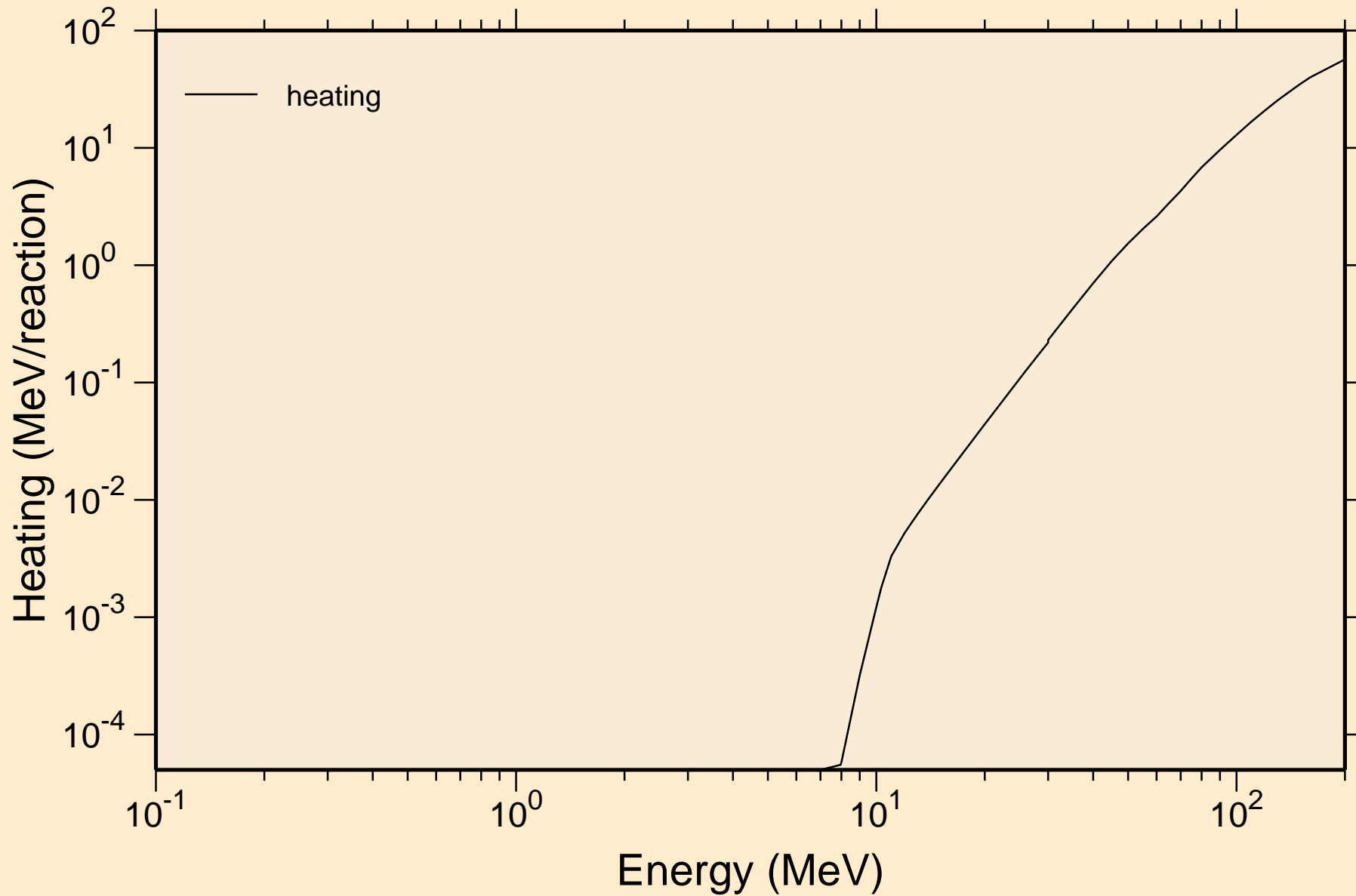

AC224 DEUTERON ACER TENDL-2024 LIBRARY; T=0.K  
Principal cross sections

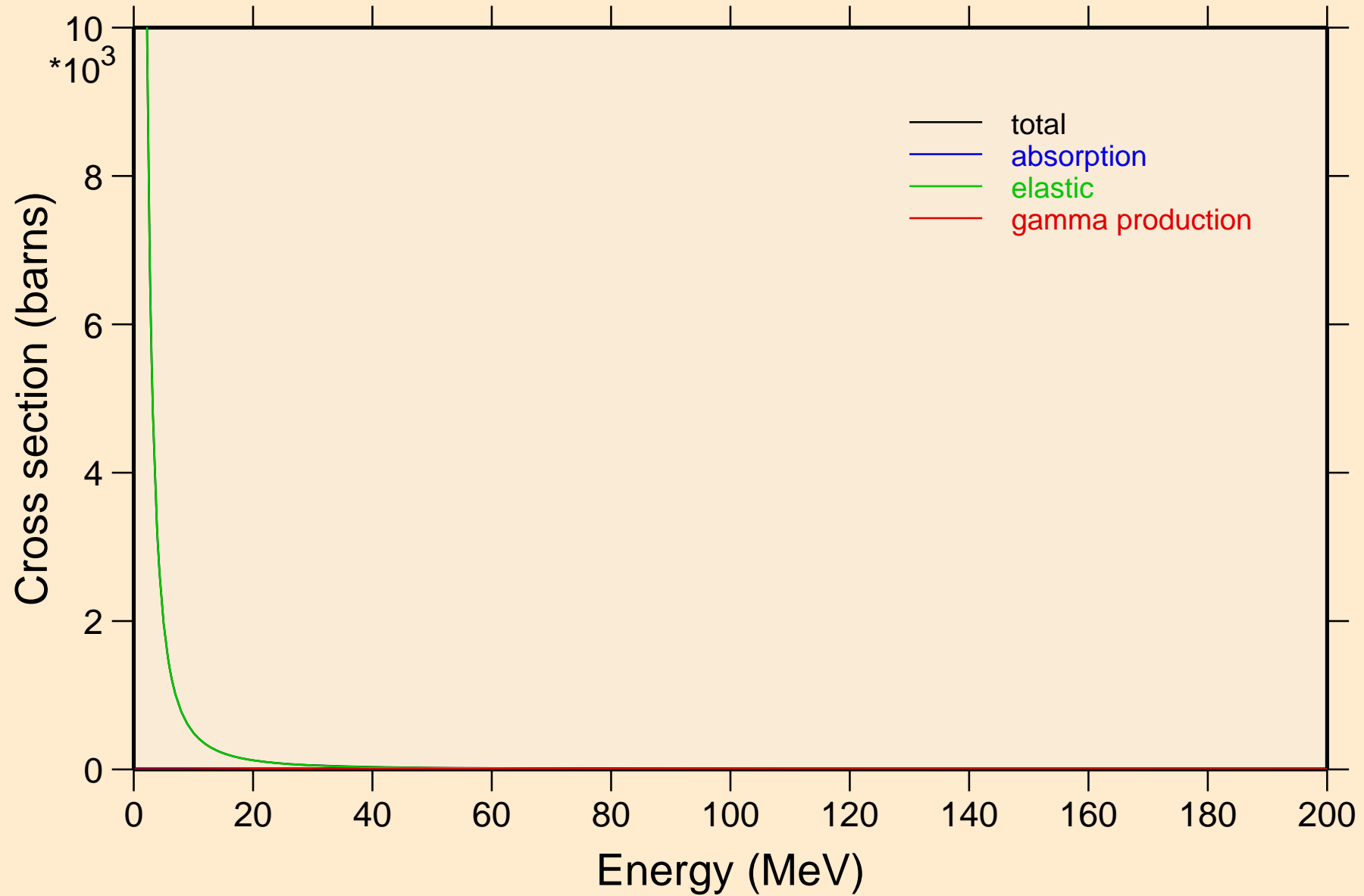

# AC224 DEUTERON ACER TENDL-2024 LIBRARY; T=0.K

## Heating

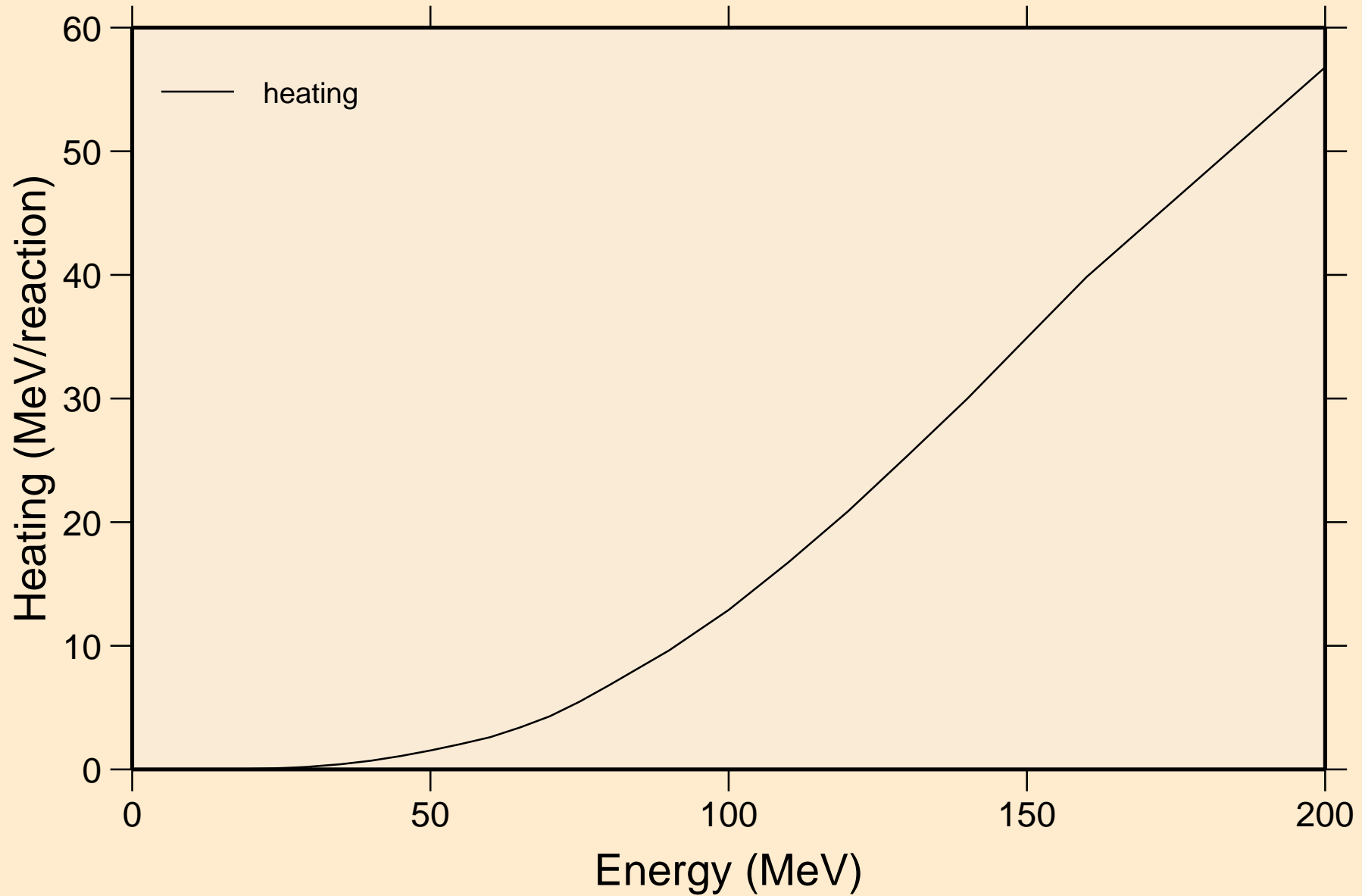

# AC224 DEUTERON ACER TENDL-2024 LIBRARY; T=0.K

## Threshold reactions

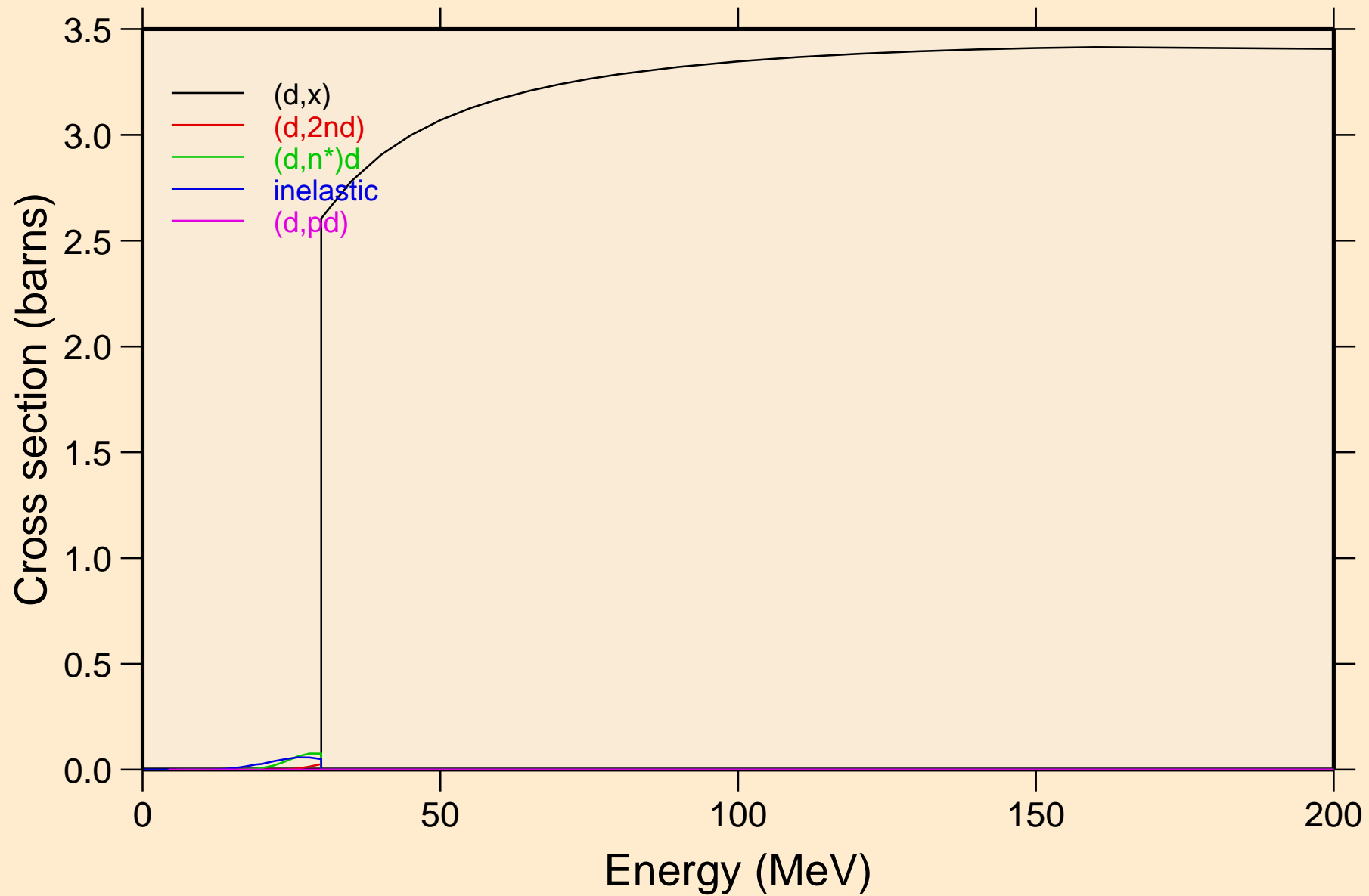

AC224 DEUTERON ACER TENDL-2024 LIBRARY; T=0.K  
Threshold reactions

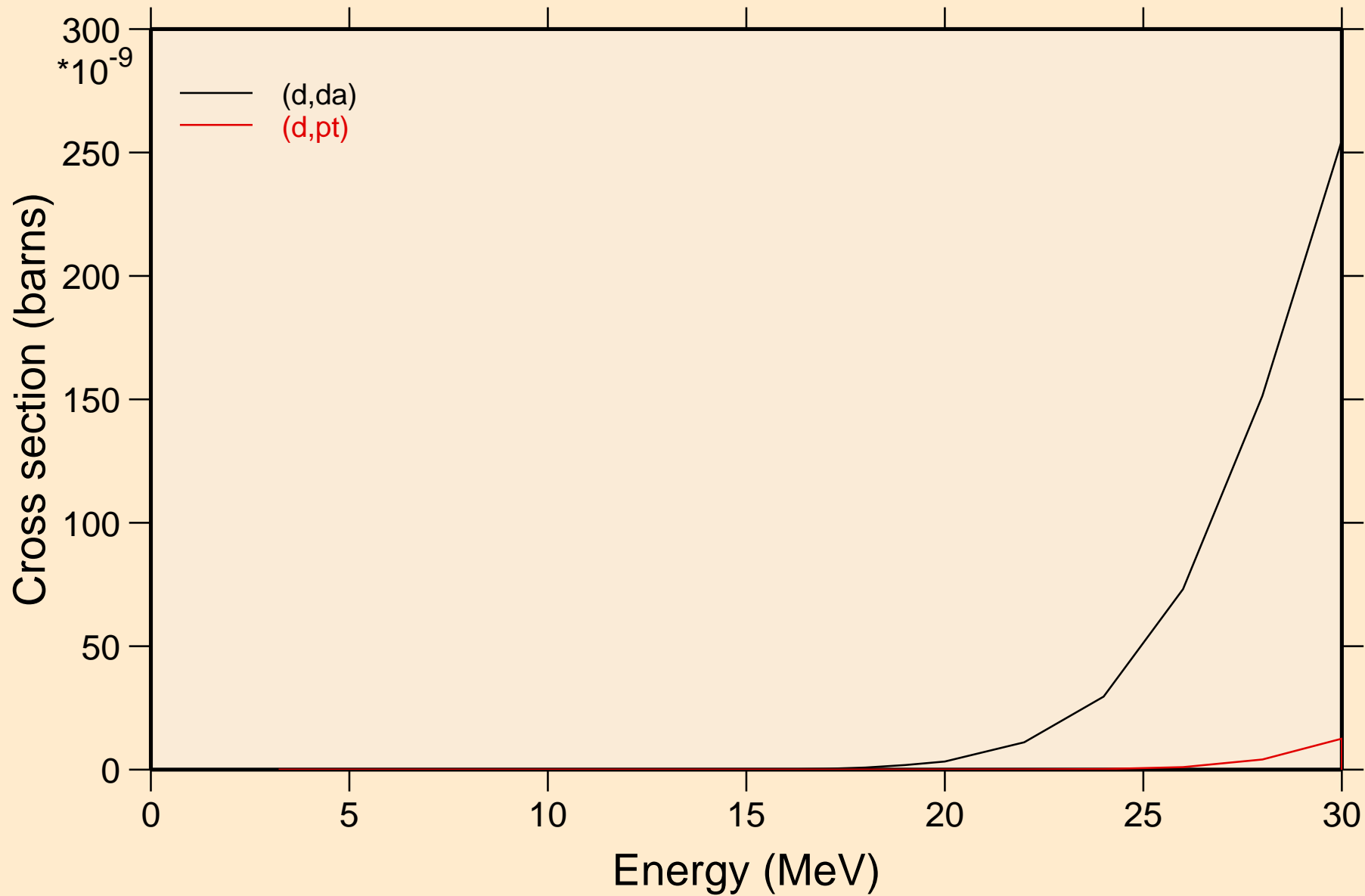

AC224 DEUTERON ACER TENDL-2024 LIBRARY; T=0.K  
Threshold reactions

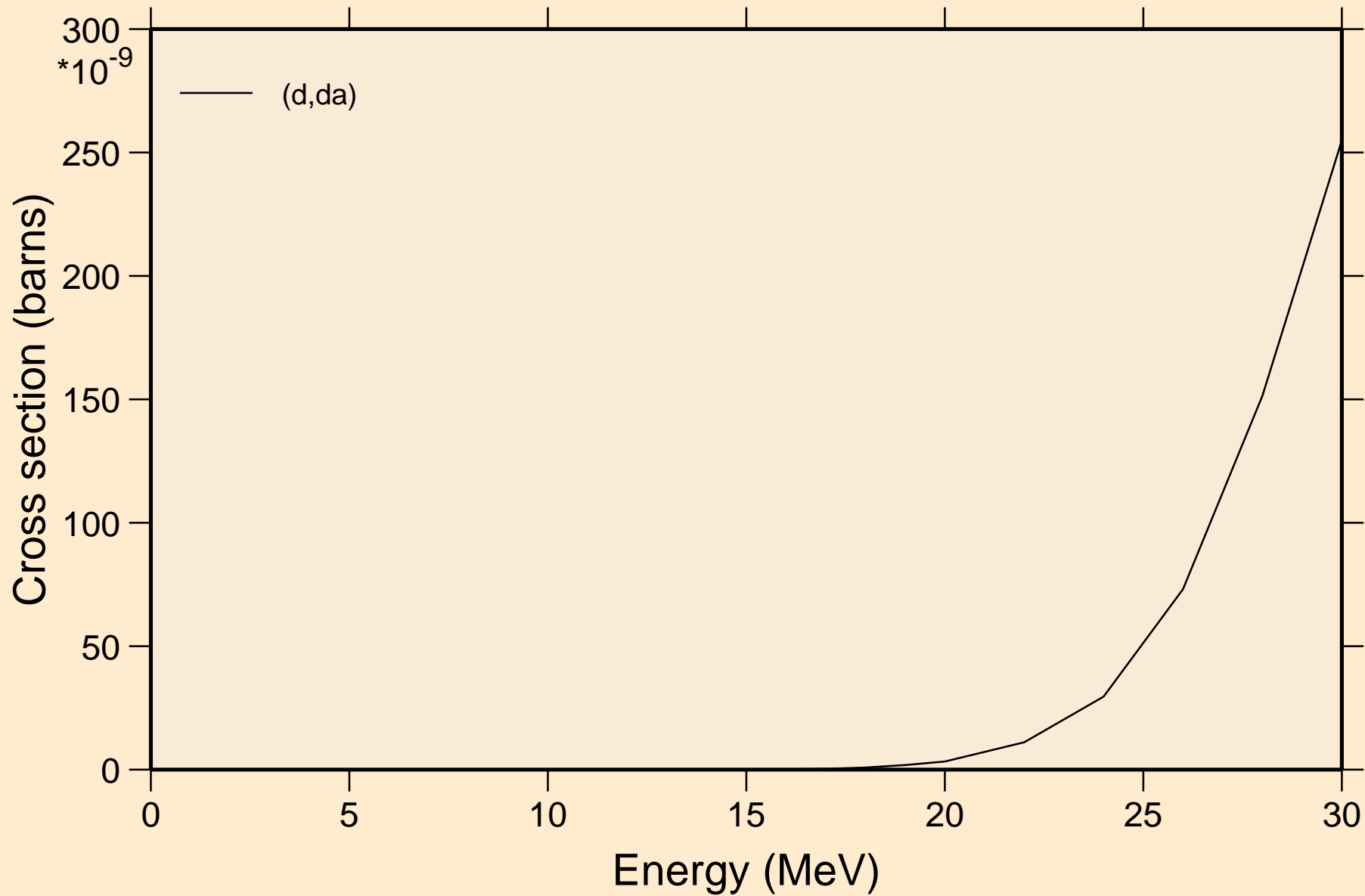

AC224 DEUTERON ACER TENDL-2024 LIBRARY; T=0.K  
angular distribution for elastic

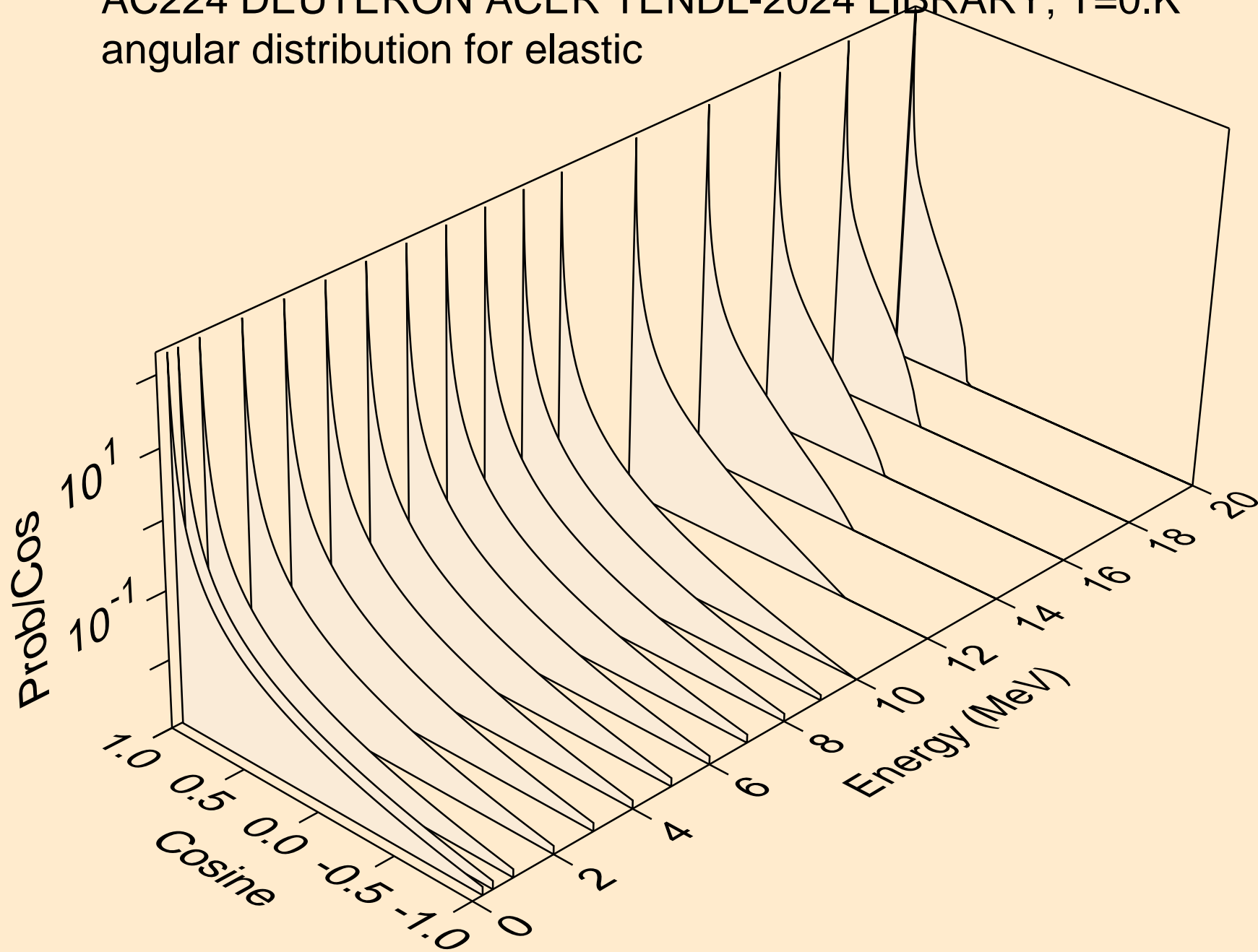

AC224 DEUTERON ACER TENDL-2024 LIBRARY; T=0.K  
angular distribution for elastic

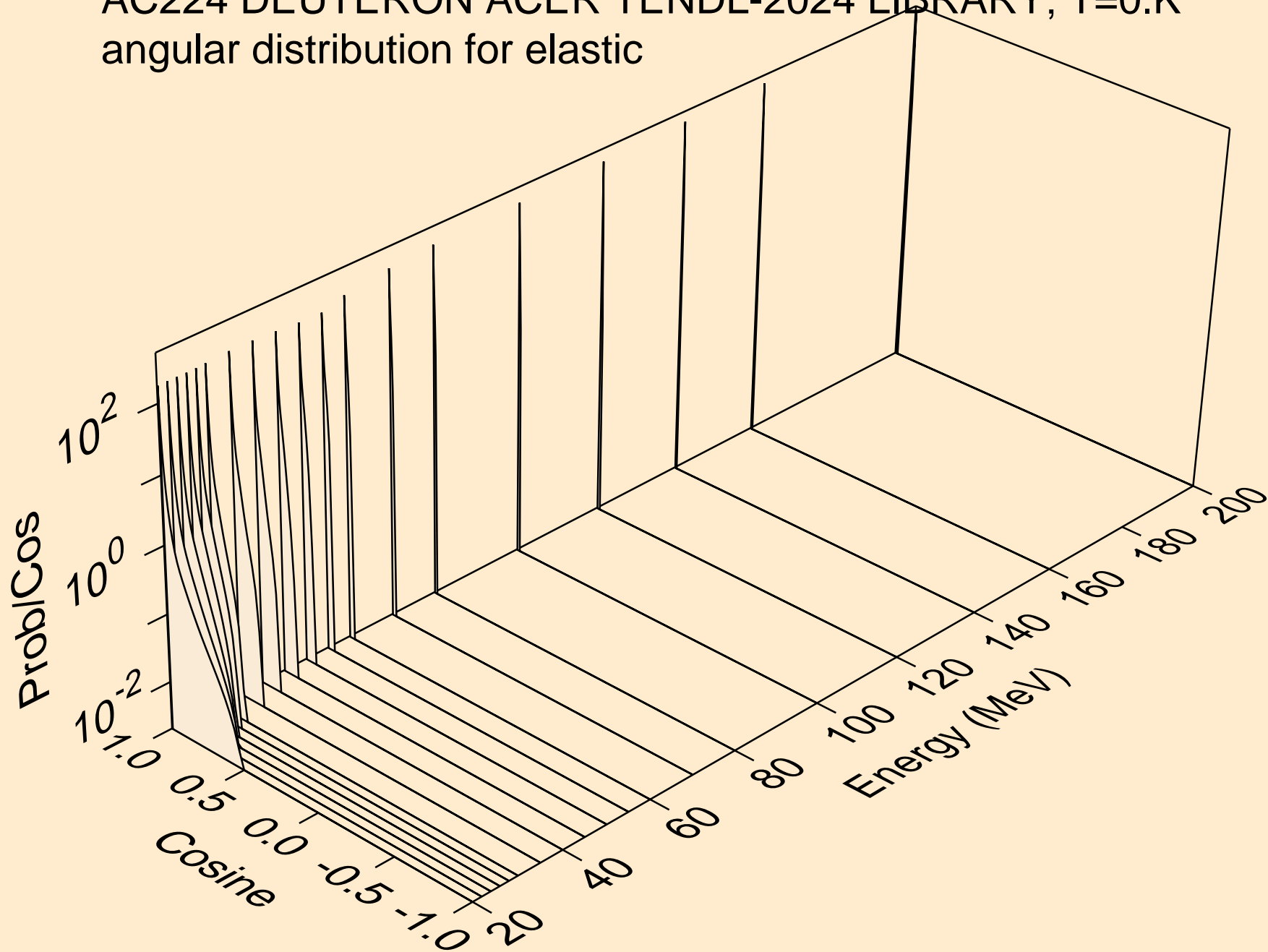

AC224 DEUTERON ACER TENDL-2024 LIBRARY; T=0.K  
Deuteron emission for (d,x)

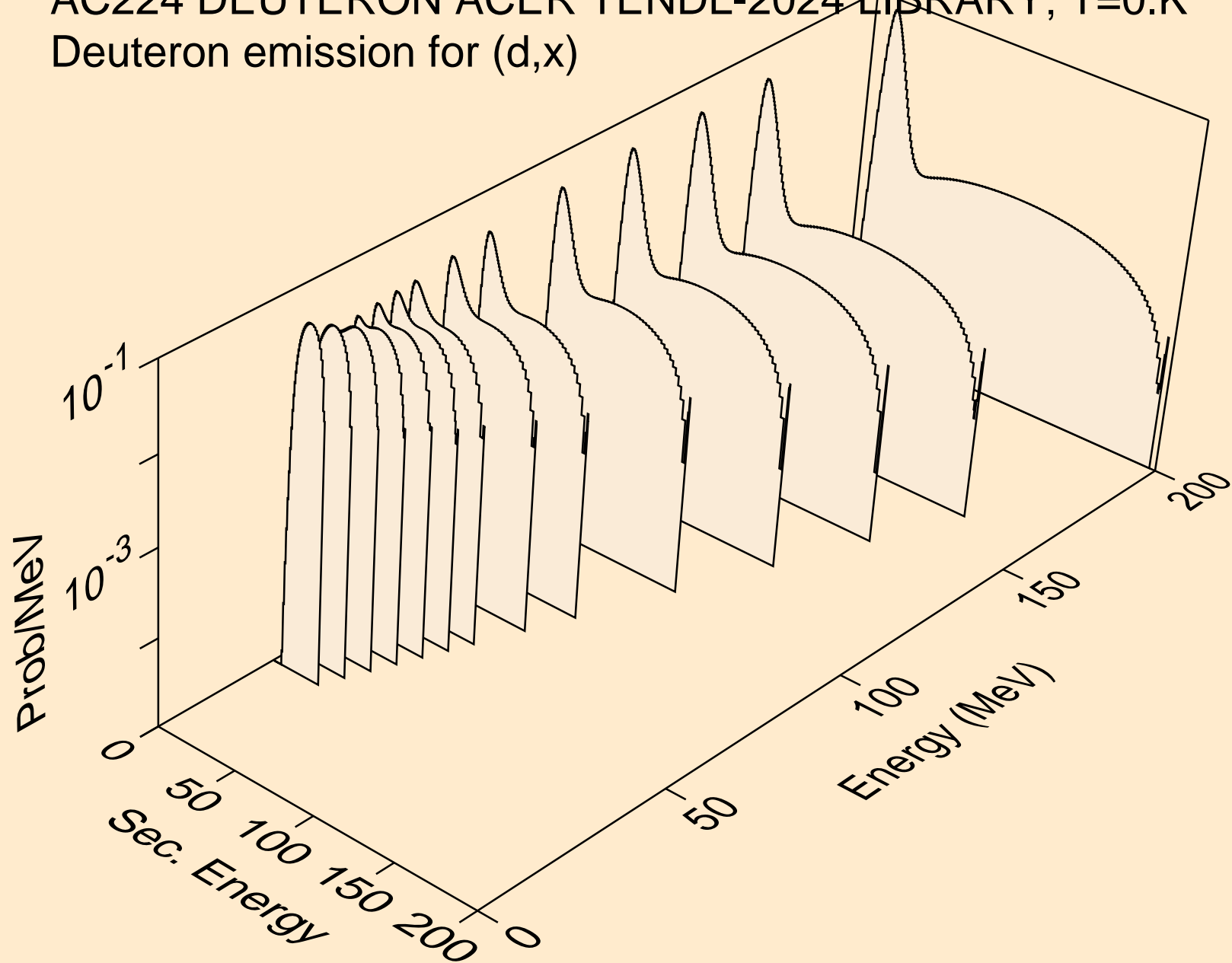

AC224 DEUTERON ACER TENDL-2024 LIBRARY; T=0.K  
Deuteron emission for (d,2nd)

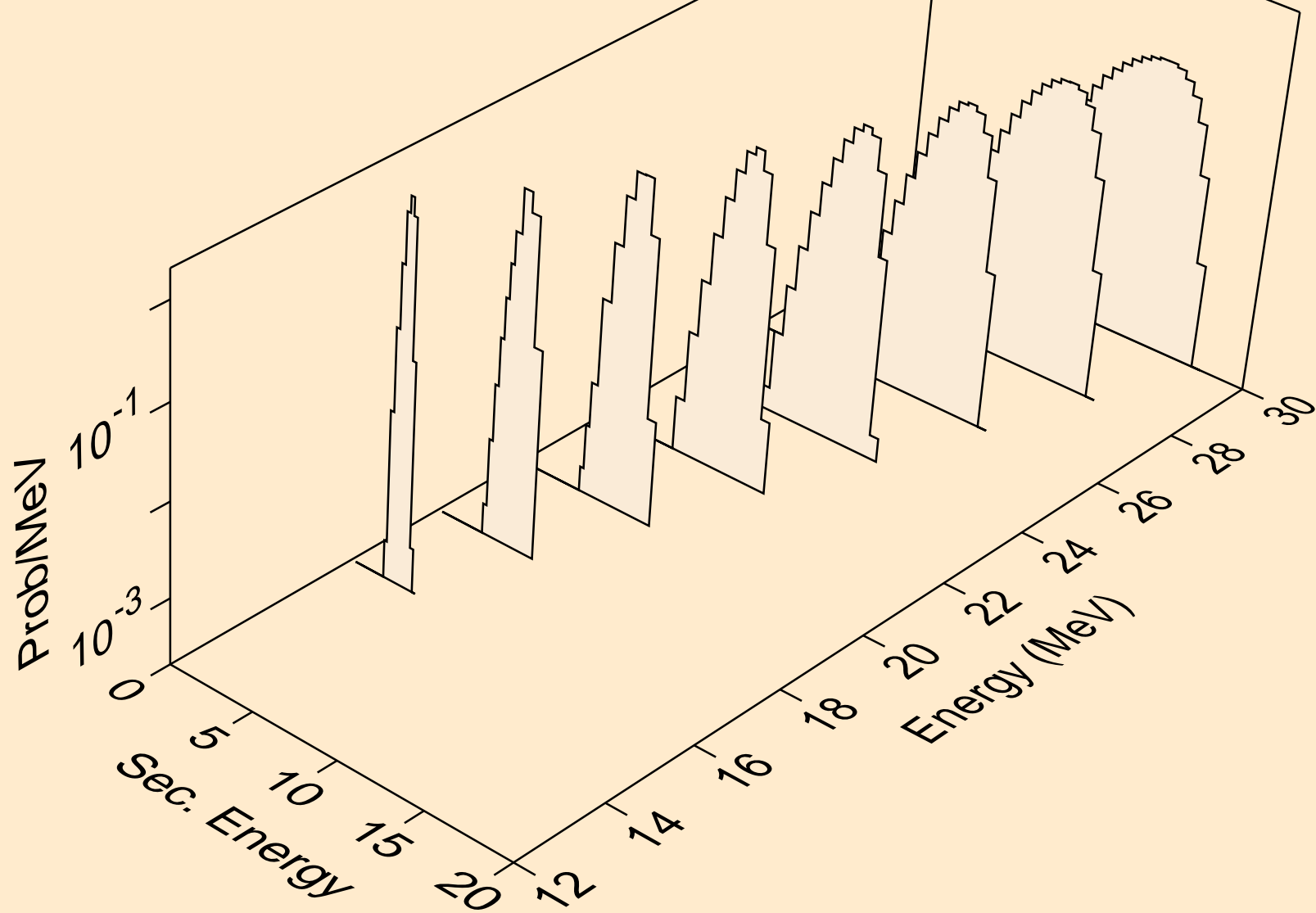

AC224 DEUTERON ACER TENDL-2024 LIBRARY; T=0.K  
Deuteron emission for (d,n\*)d

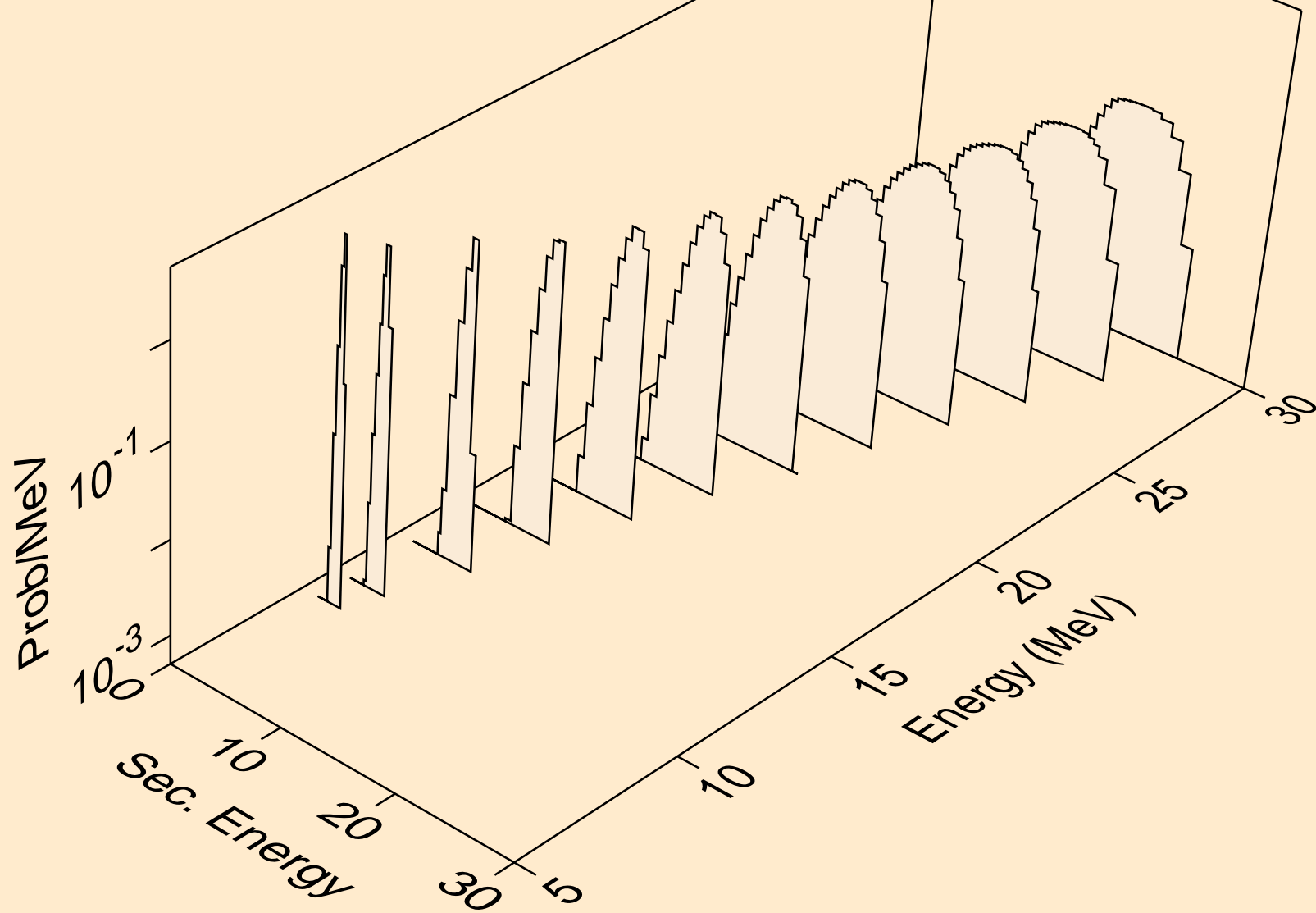

AC224 DEUTERON ACER TENDL-2024 LIBRARY; T=0.K  
Deuteron emission for inelastic

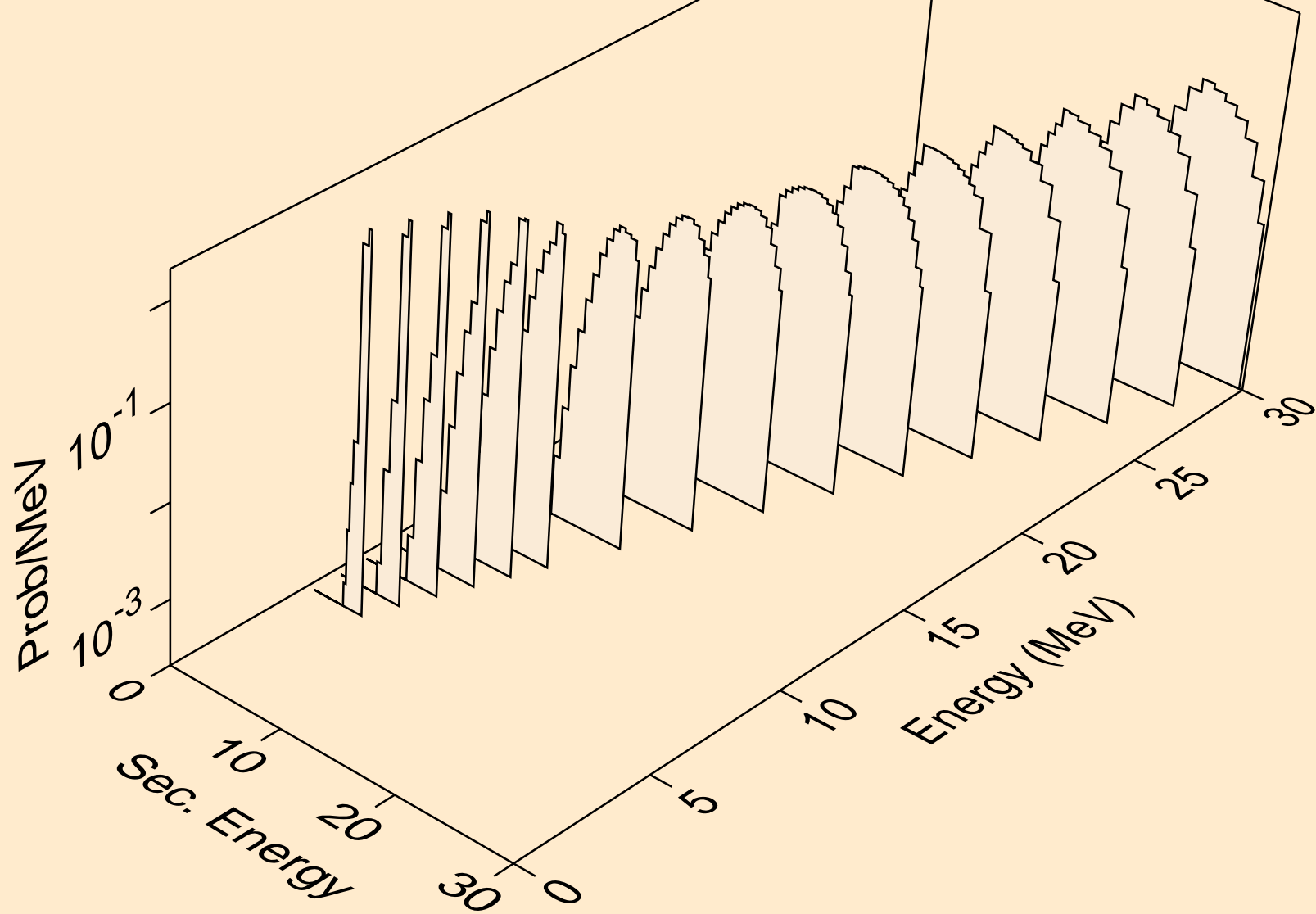

AC224 DEUTERON ACER TENDL-2024 LIBRARY; T=0.K  
Deuteron emission for (d,pd)

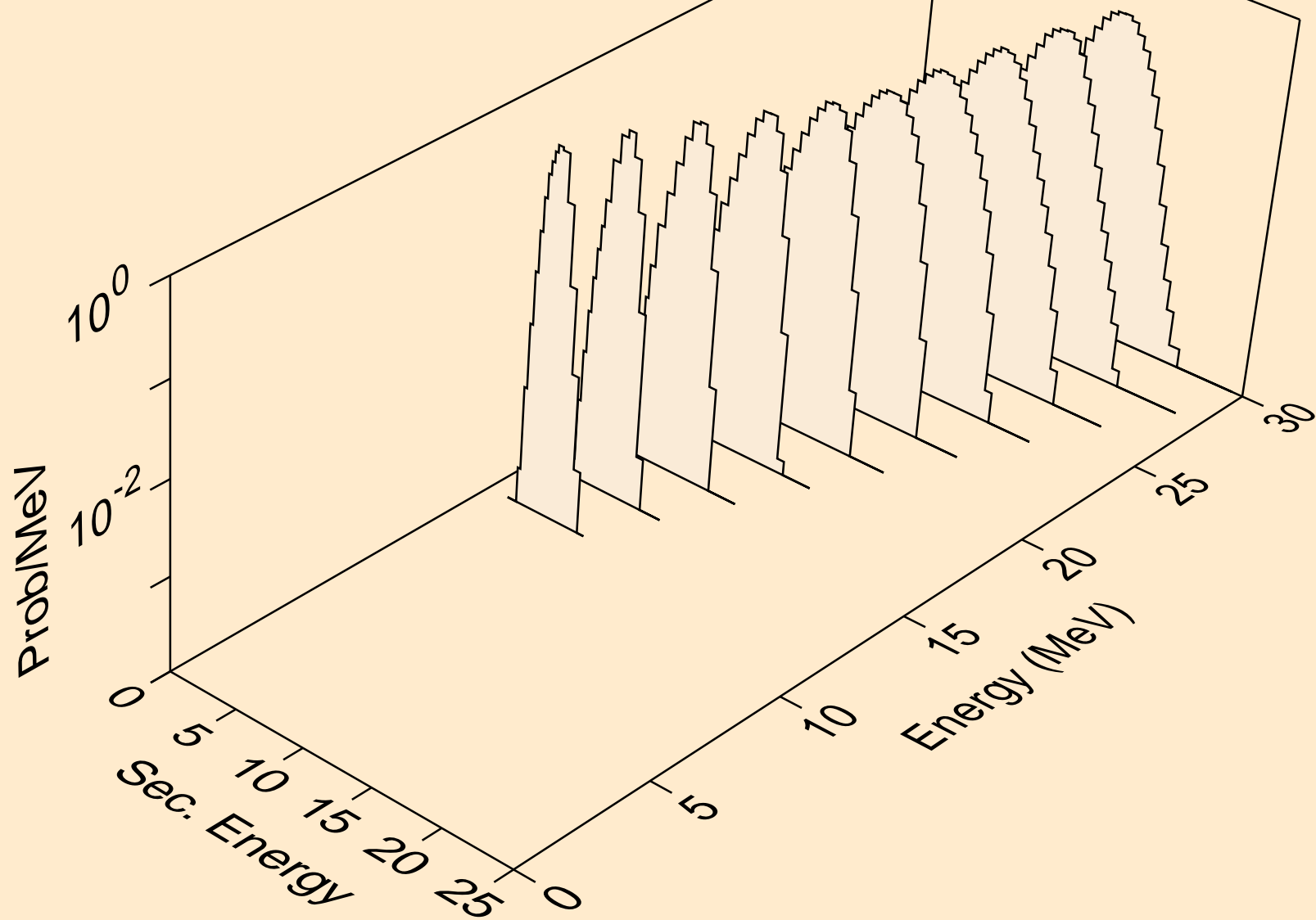

AC224 DEUTERON ACER TENDL-2024 LIBRARY; T=0.K  
Deuteron emission for (d,da)

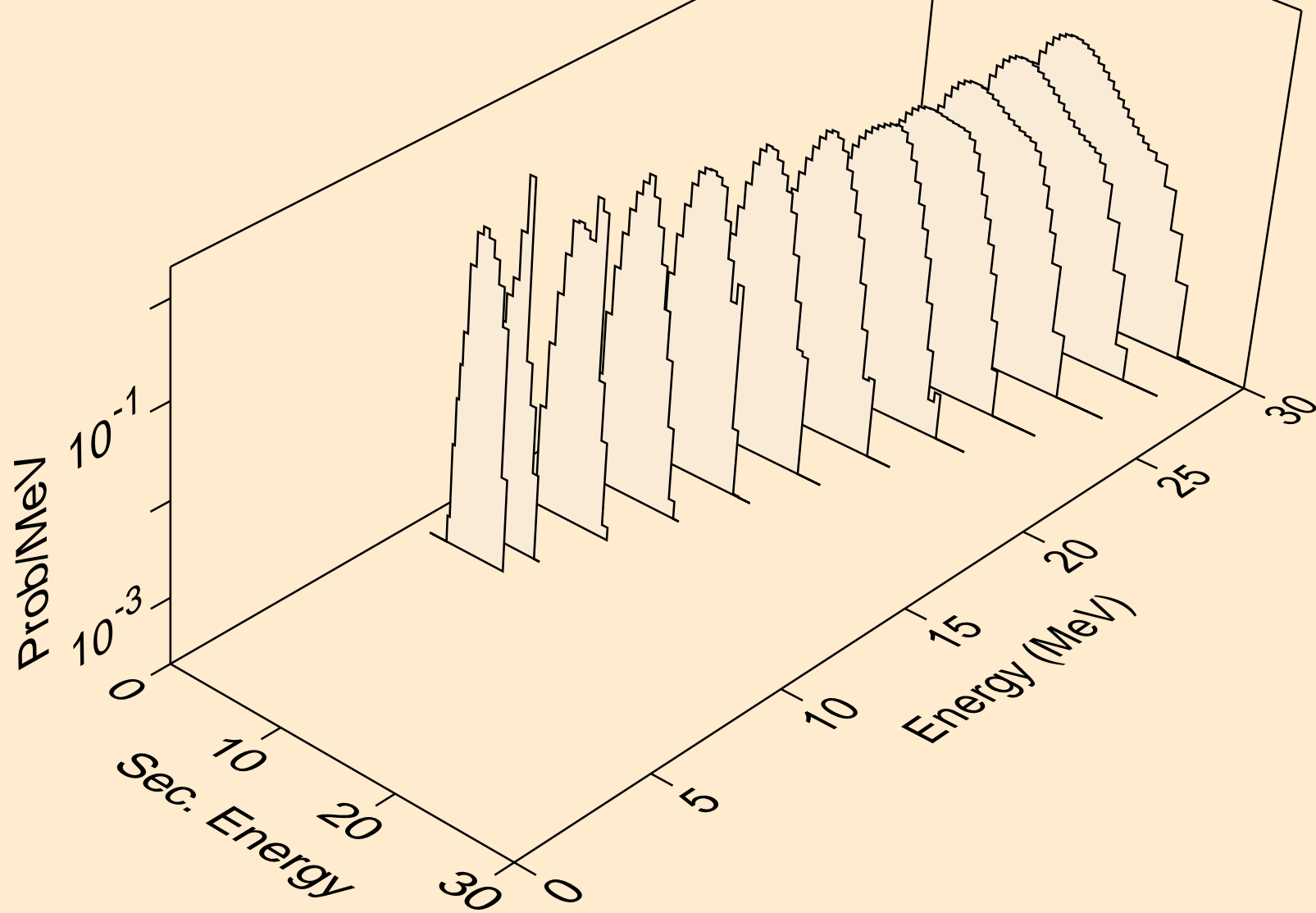

AC224 DEUTERON ACER TENDL-2024 LIBRARY; T=0.K  
Photon emission for (z,n)

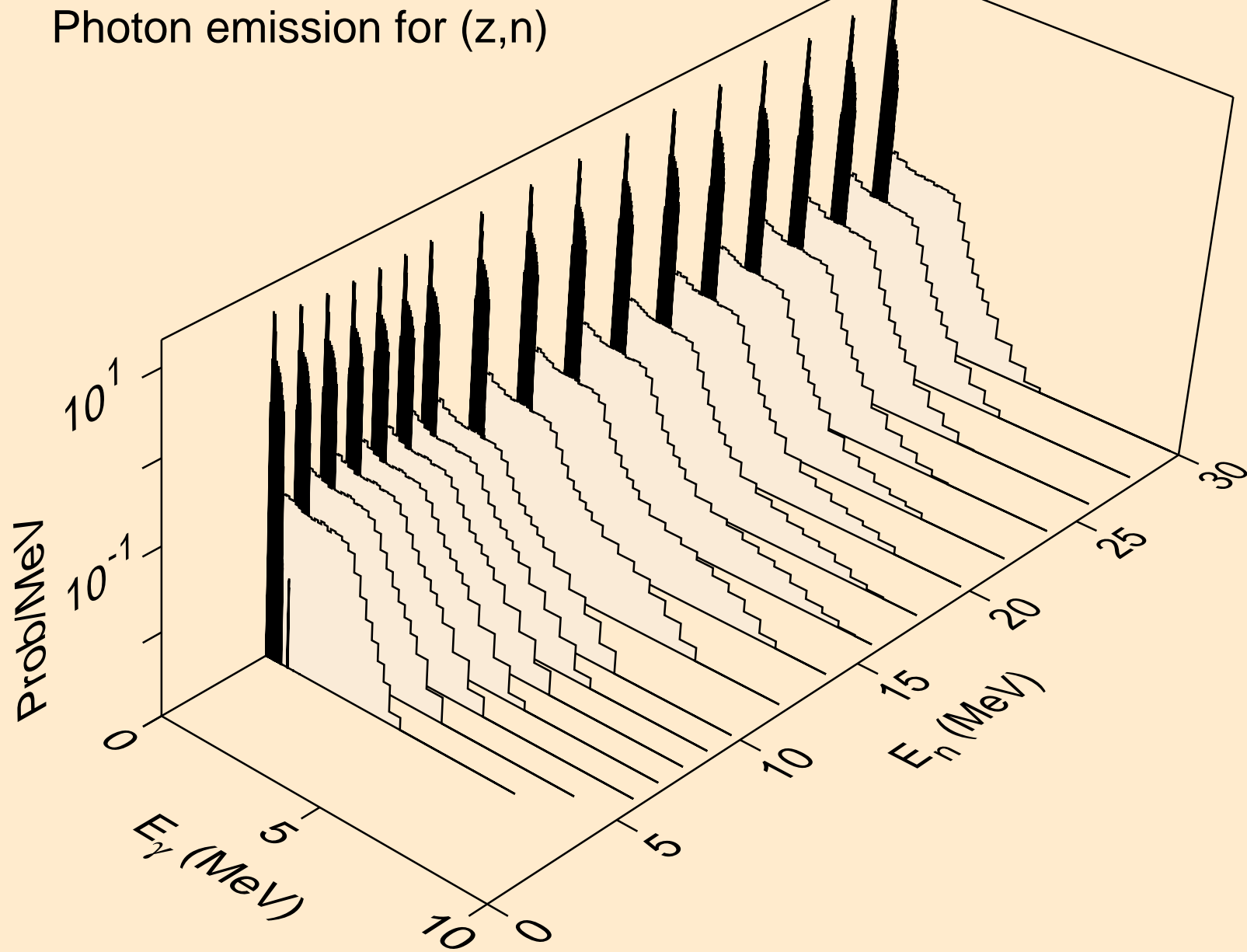

AC224 DEUTERON ACER TENDL-2024 LIBRARY; T=0.K  
Photon emission for (z,x)

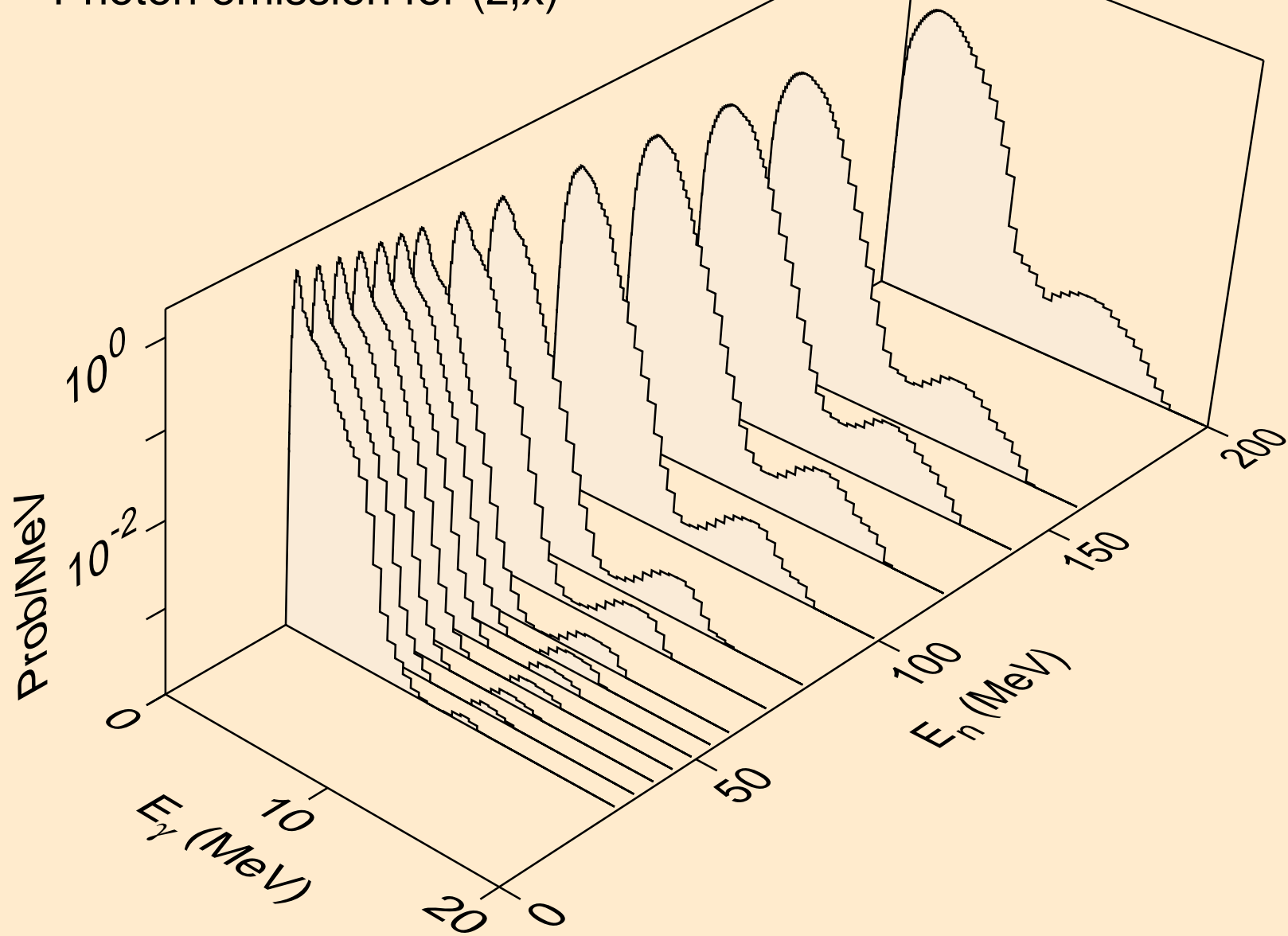

AC224 DEUTERON ACER TENDL-2024 LIBRARY; T=0.K  
Photon emission for (n,2nd)

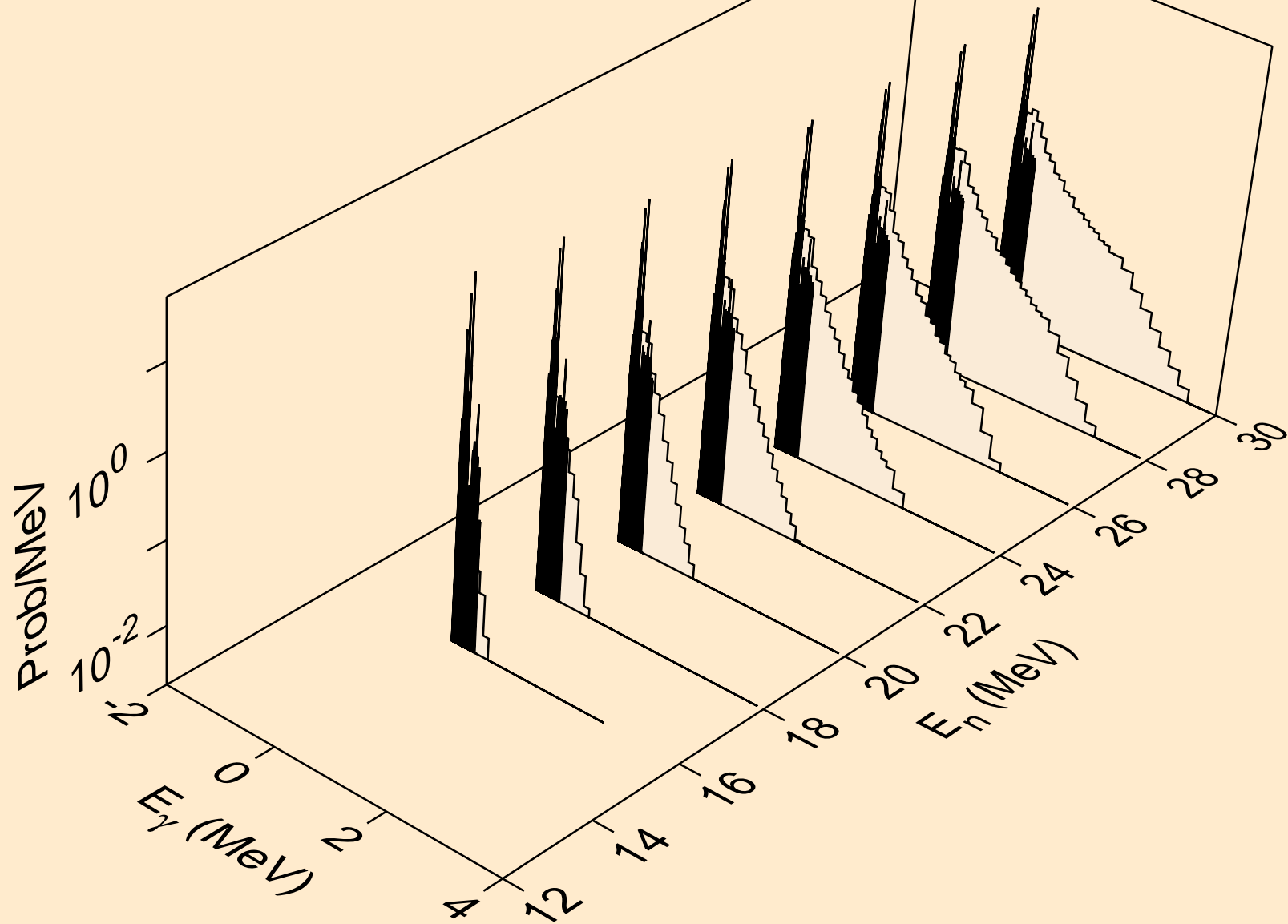

AC224 DEUTERON ACER TENDL-2024 LIBRARY; T=0.K  
Photon emission for (n,2n)

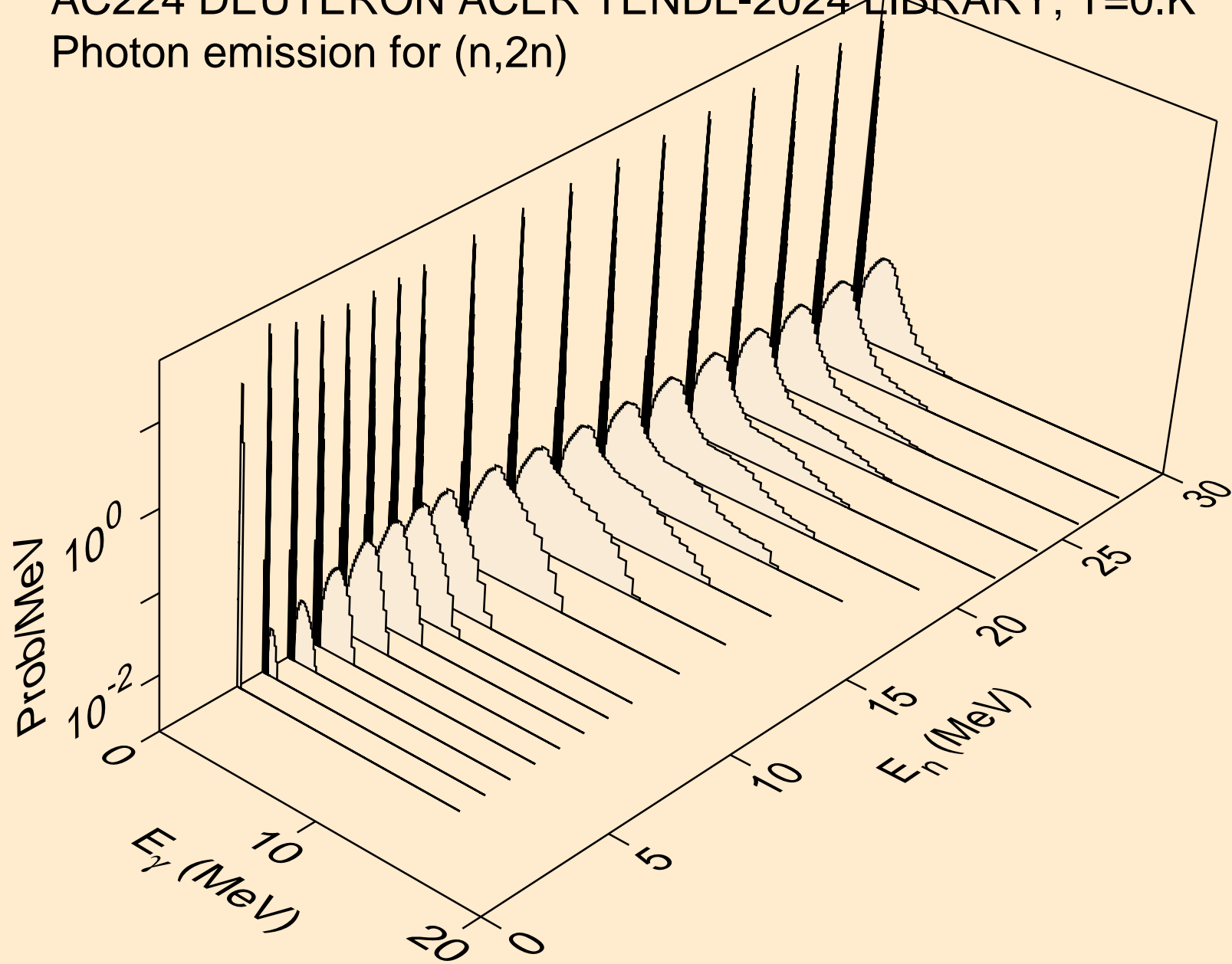

AC224 DEUTERON ACER TENDL-2024 LIBRARY; T=0.K  
Photon emission for (n,3n)

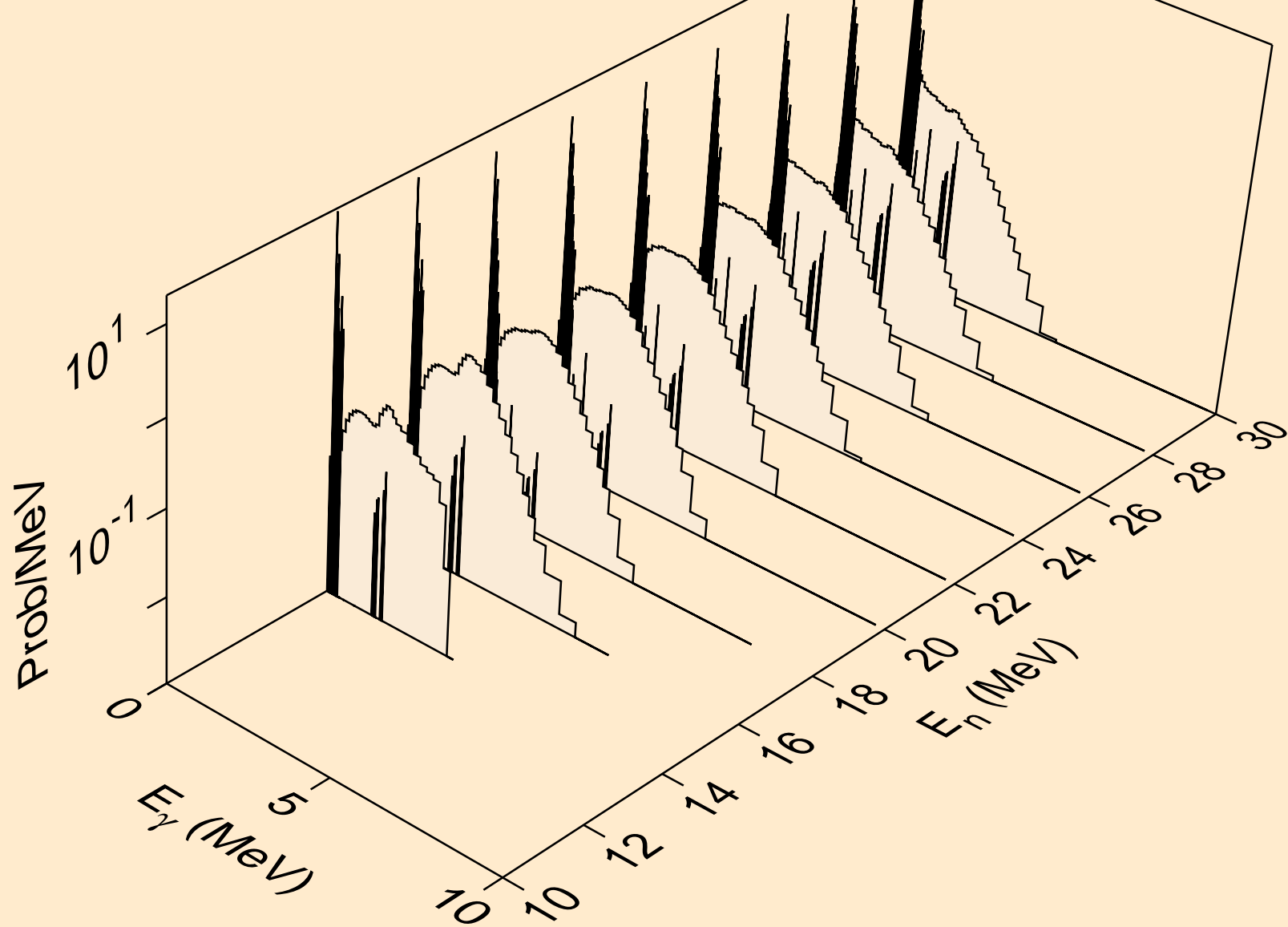

AC224 DEUTERON ACER TENDL-2024 LIBRARY; T=0.K  
Photon emission for (n,n\*)a

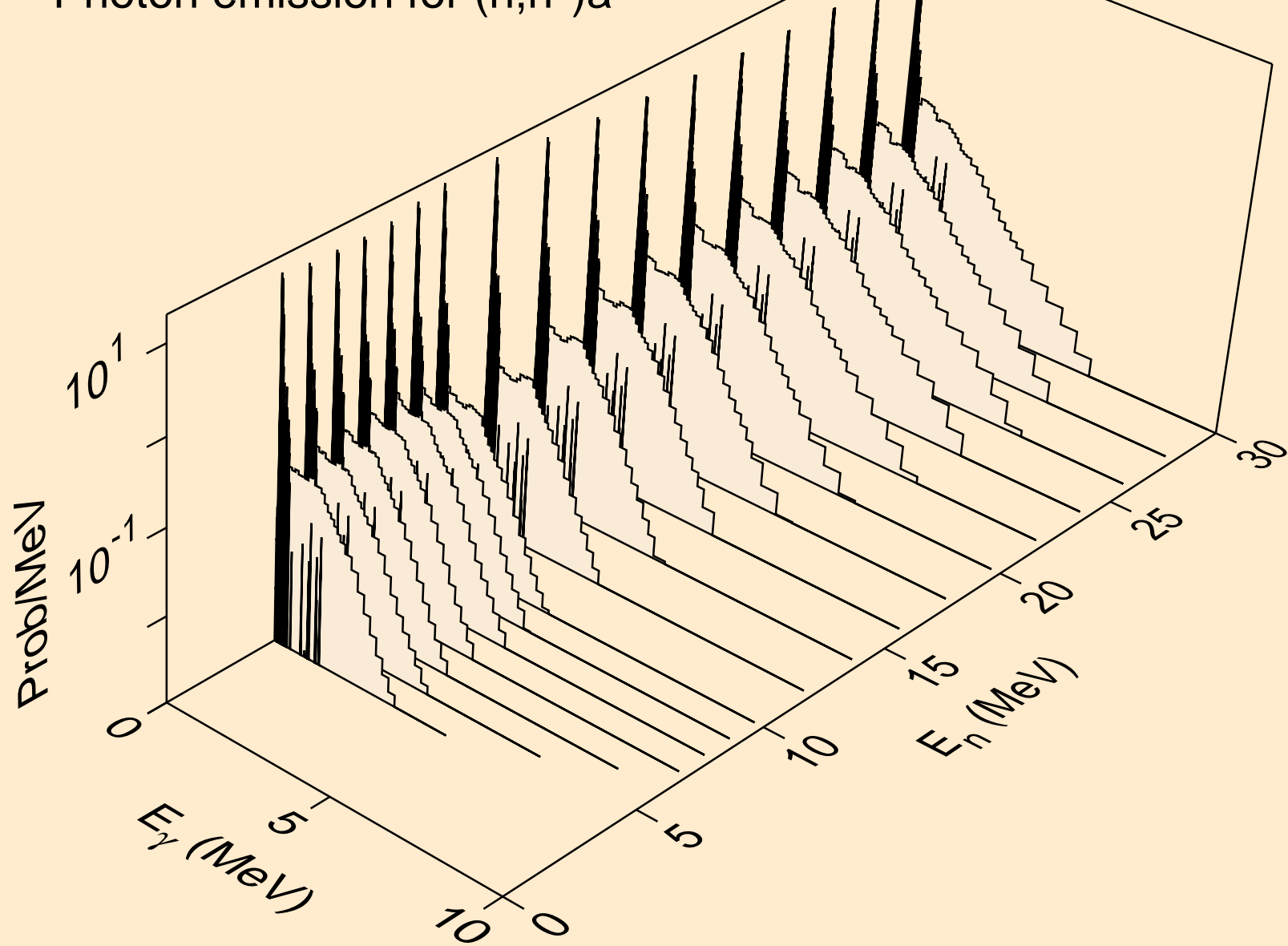

AC224 DEUTERON ACER TENDL-2024 LIBRARY; T=0.K  
Photon emission for (n,2n)a

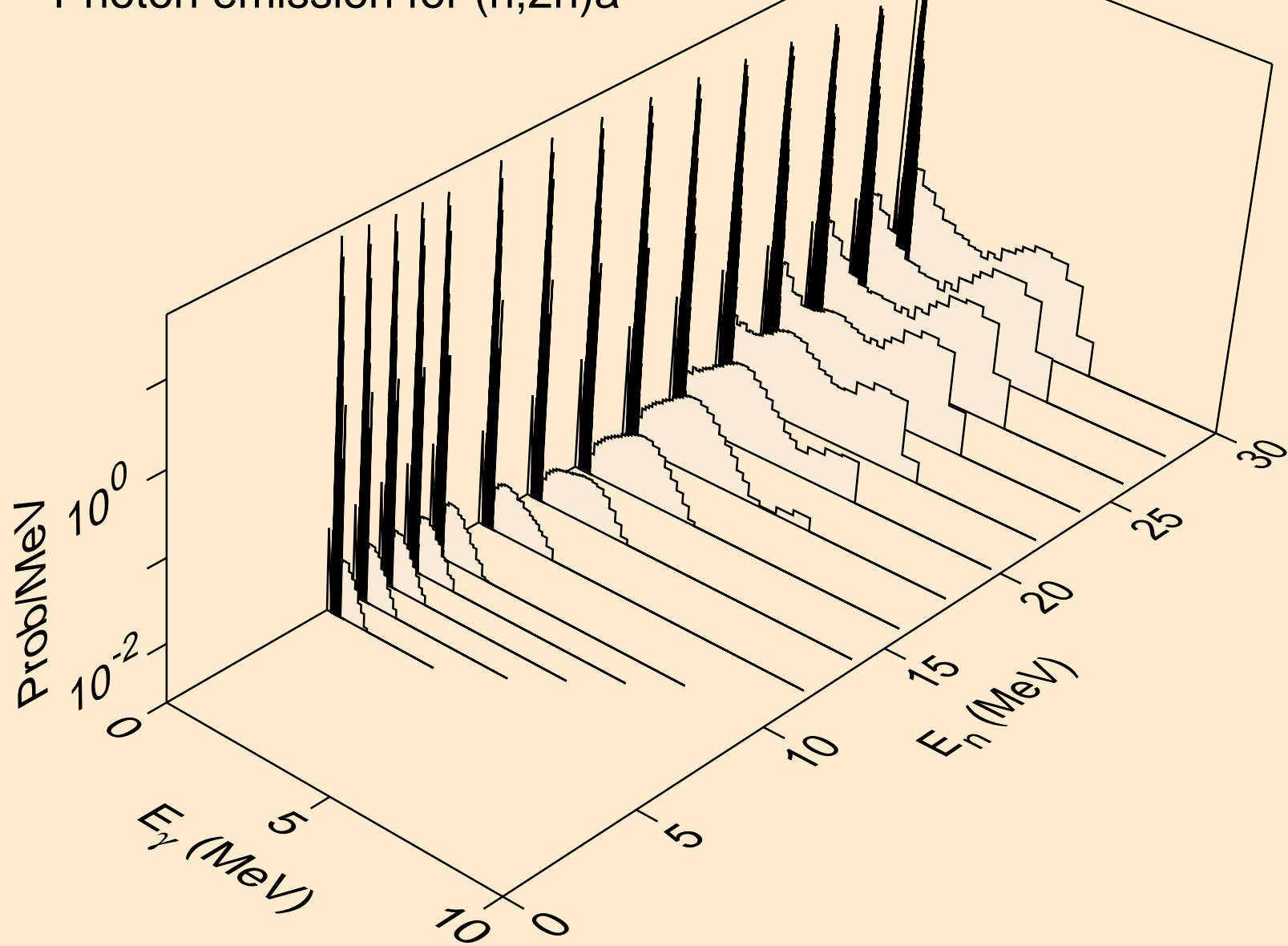

AC224 DEUTERON ACER TENDL-2024 LIBRARY; T=0.K  
Photon emission for (n,3n)a

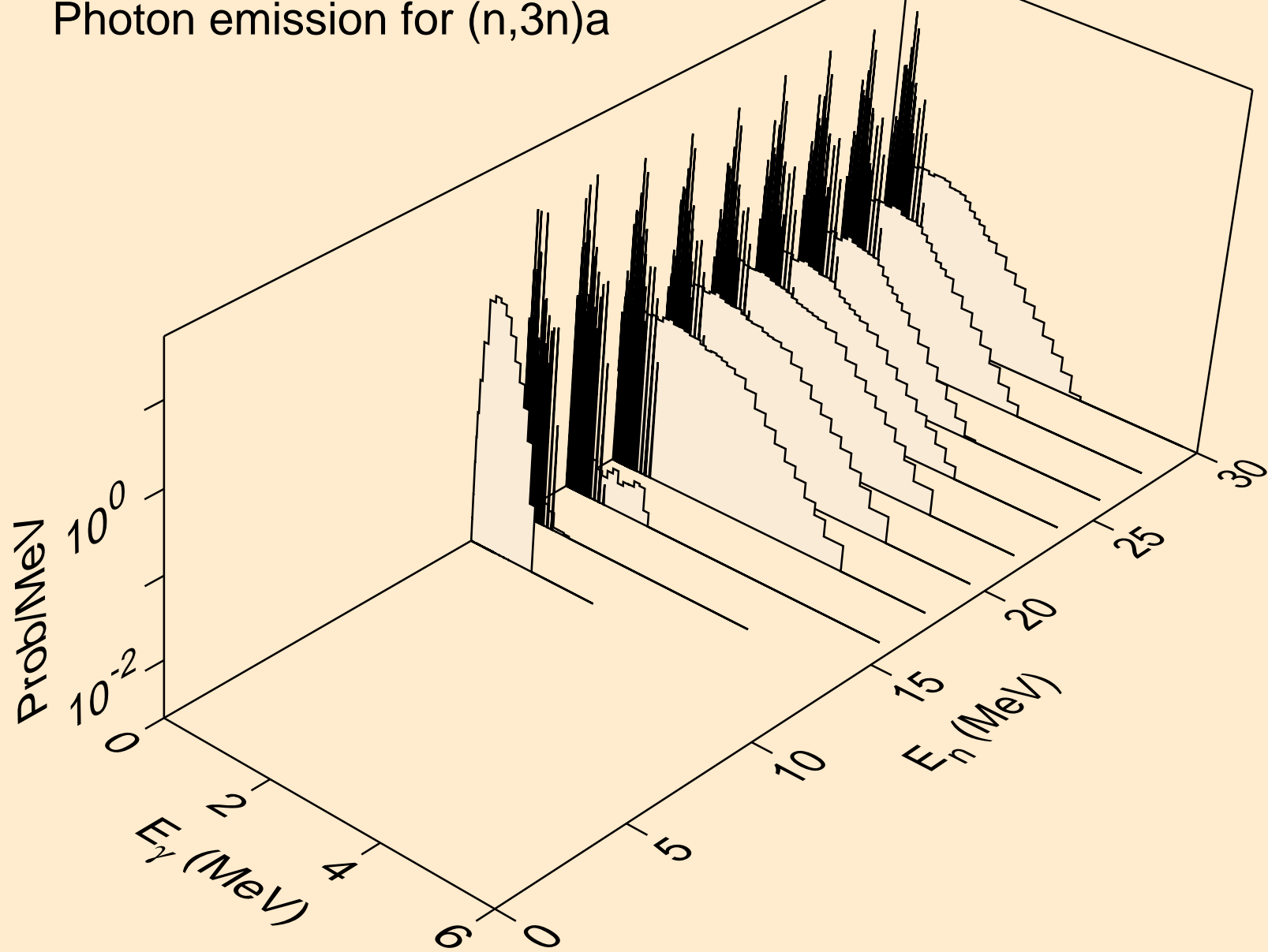

AC224 DEUTERON ACER TENDL-2024 LIBRARY; T=0.K  
Photon emission for (n,n\*)p

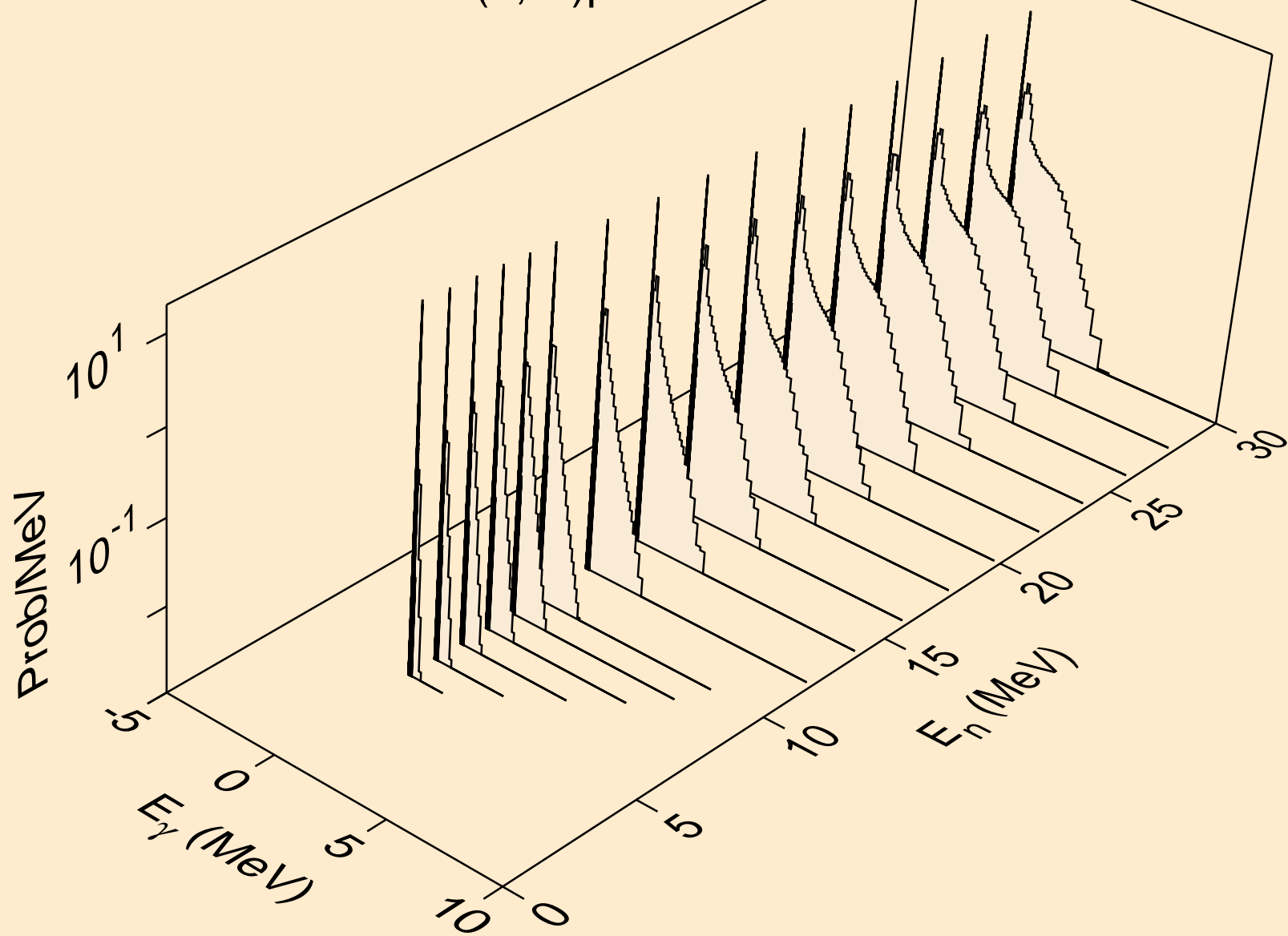

AC224 DEUTERON ACER TENDL-2024 LIBRARY; T=0.K  
Photon emission for (n,n\*)2a

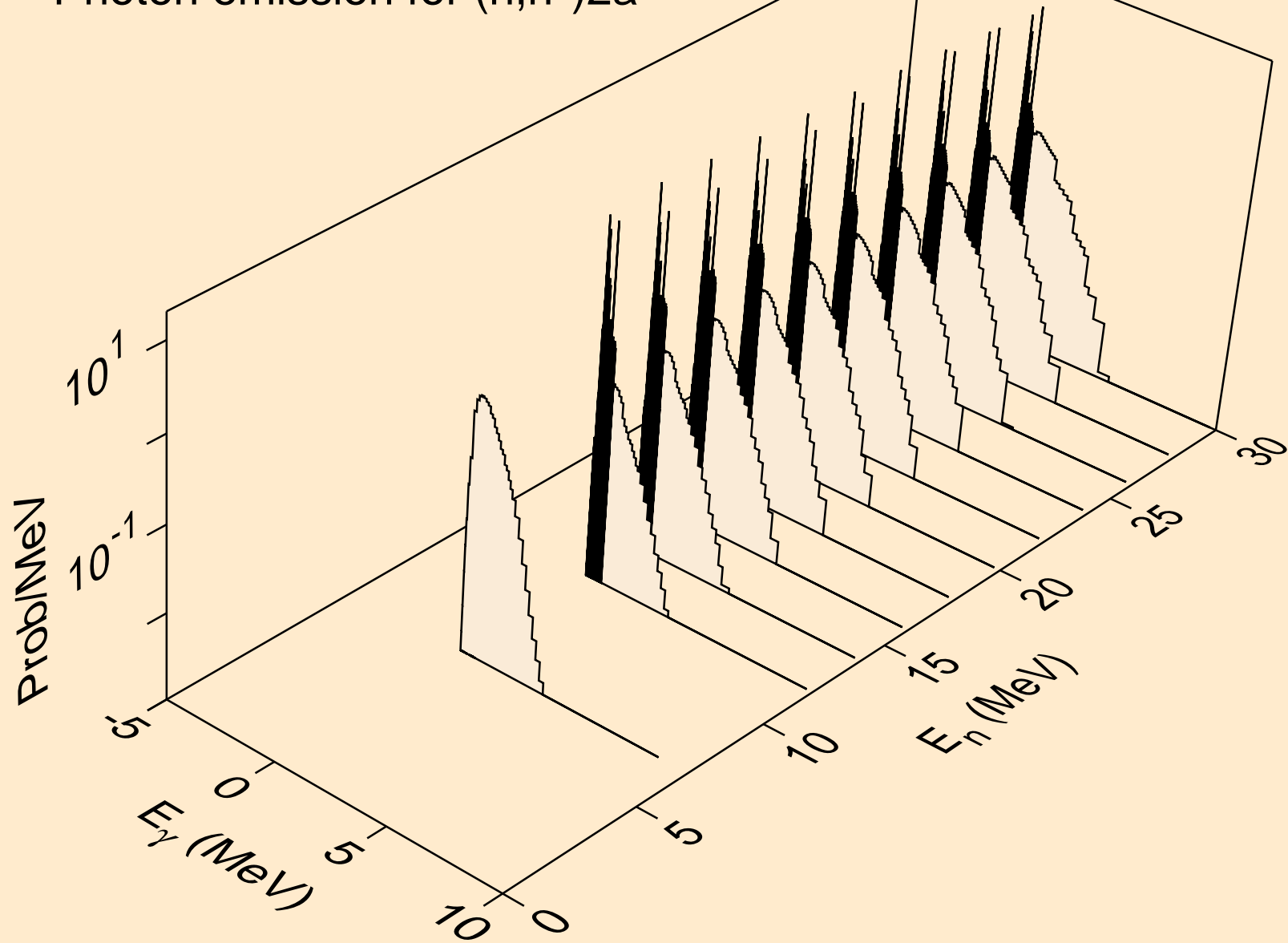

AC224 DEUTERON ACER TENDL-2024 LIBRARY; T=0.K  
Photon emission for (n,2n)2a

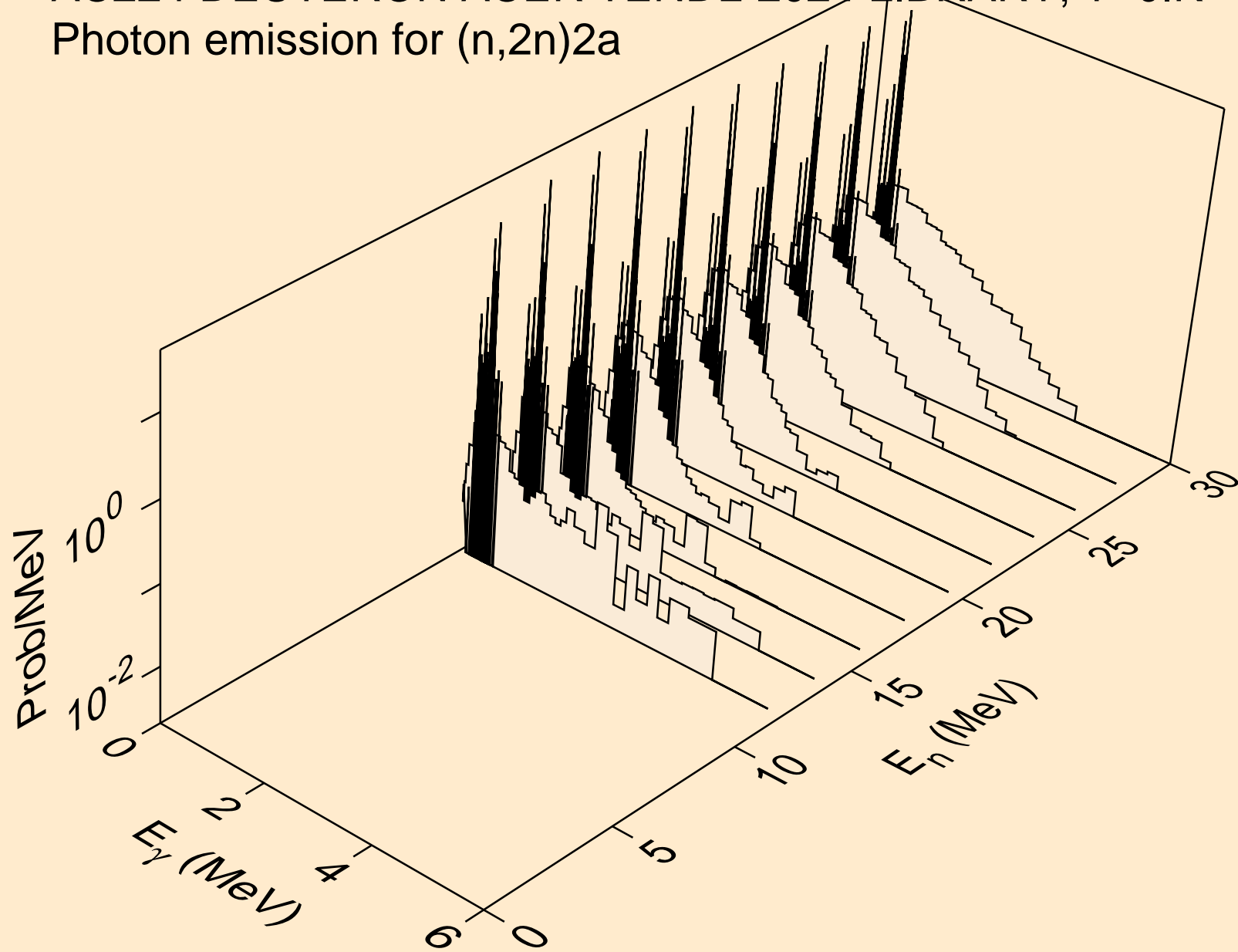

AC224 DEUTERON ACER TENDL-2024 LIBRARY; T=0.K  
Photon emission for (n,n\*)d

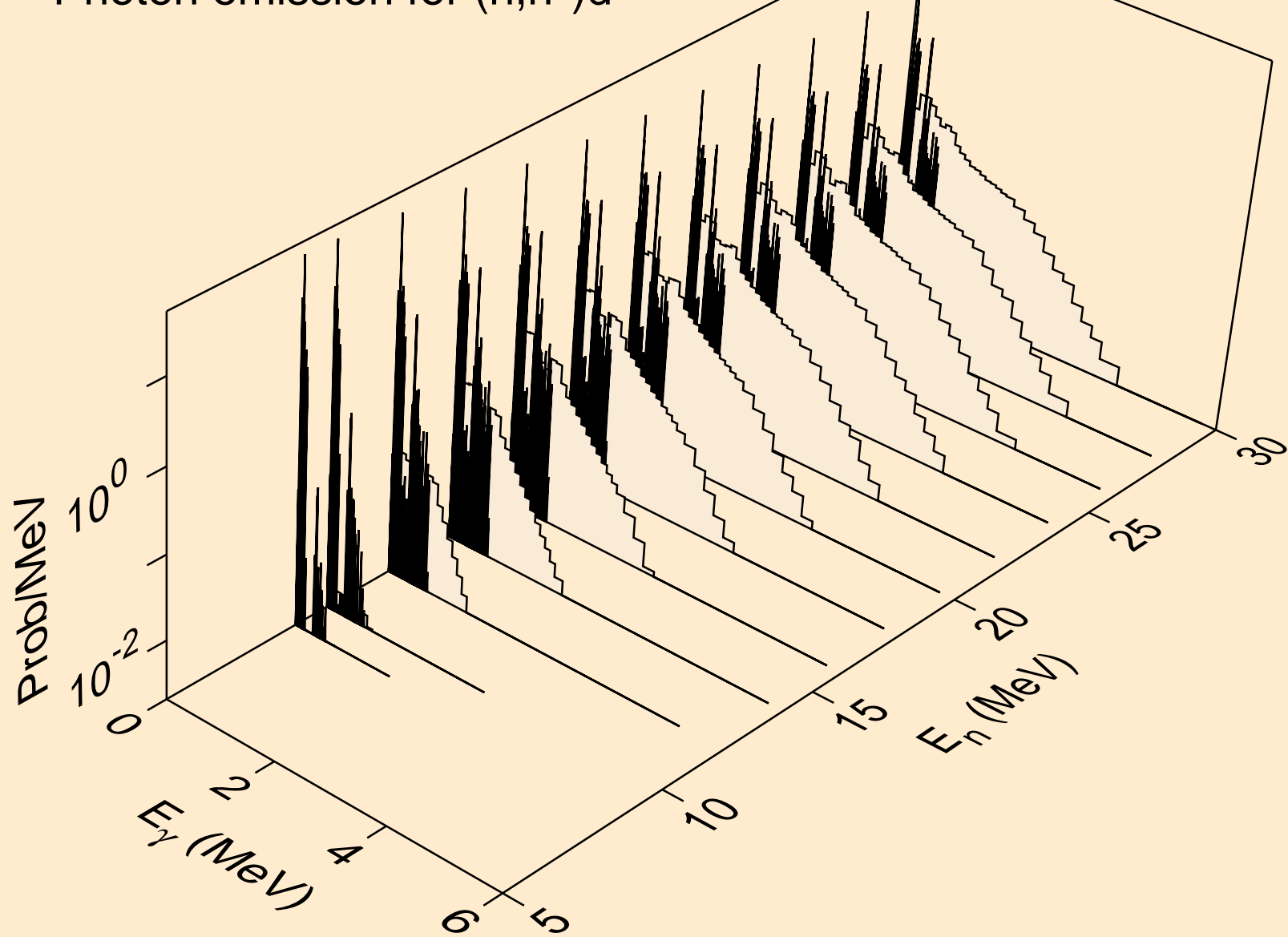

AC224 DEUTERON ACER TENDL-2024 LIBRARY; T=0.K  
Photon emission for (n,n\*)t

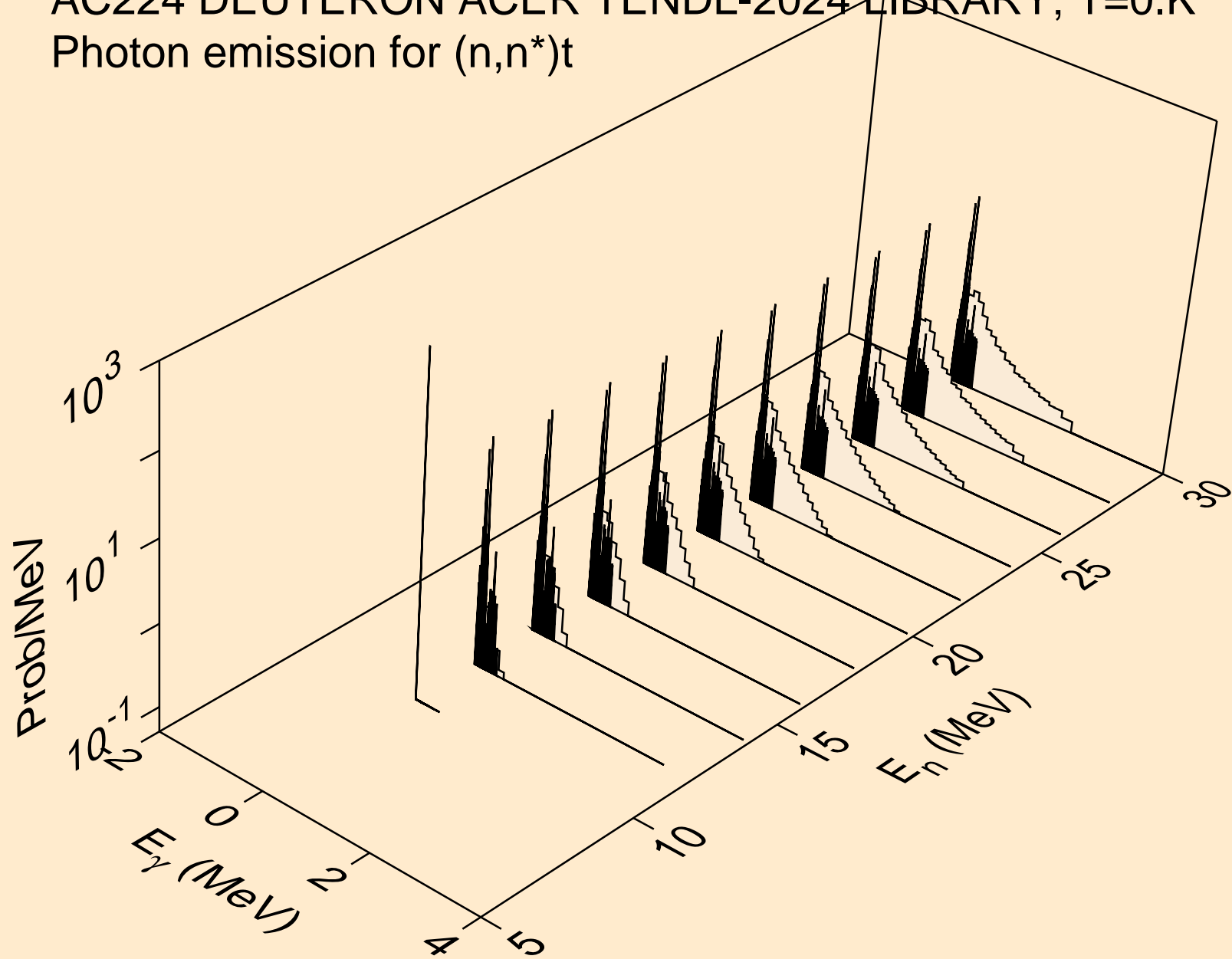

AC224 DEUTERON ACER TENDL-2024 LIBRARY; T=0.K  
Photon emission for (n,n\*)he3

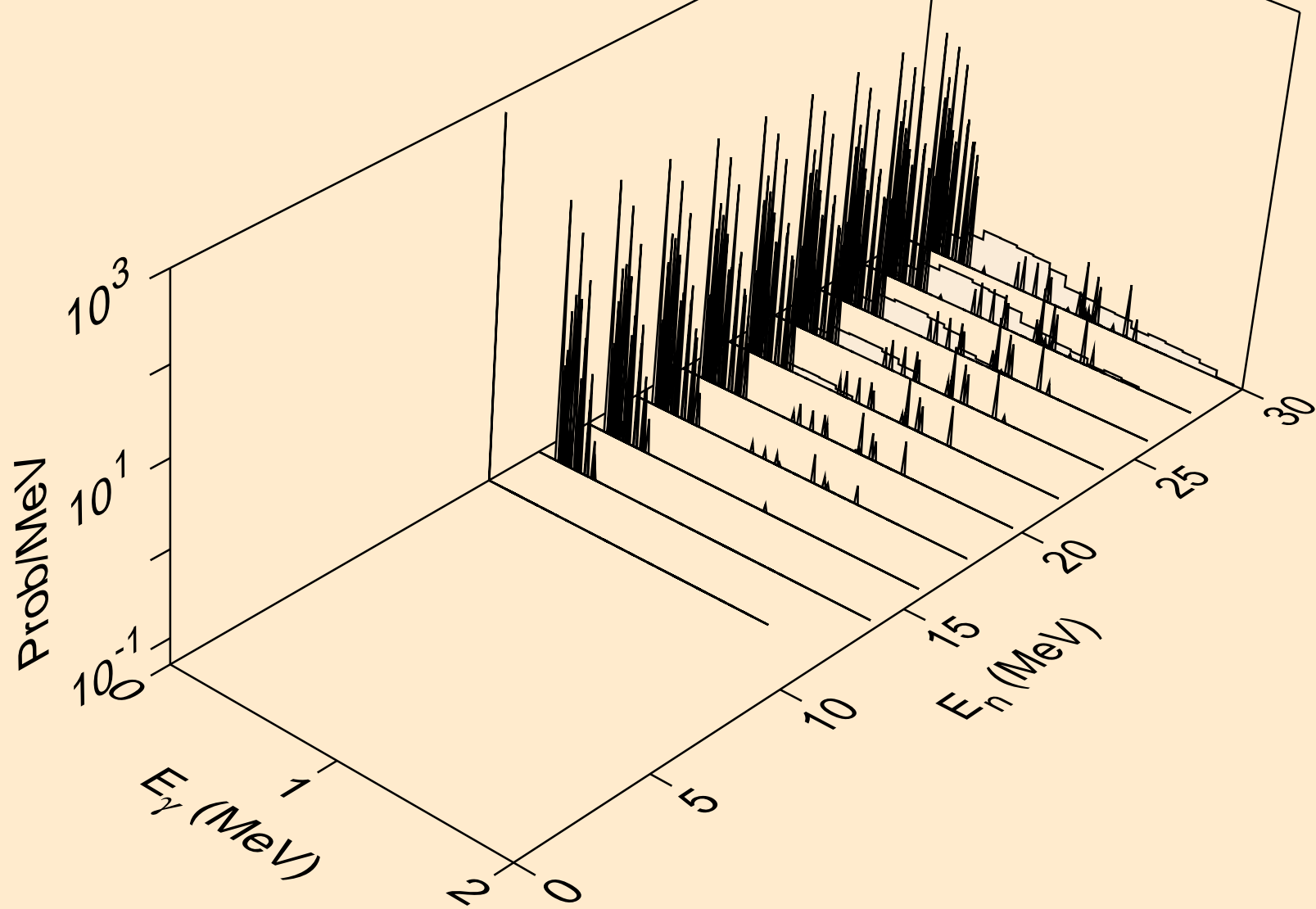

AC224 DEUTERON ACER TENDL-2024 LIBRARY; T=0.K  
Photon emission for (n,4n)

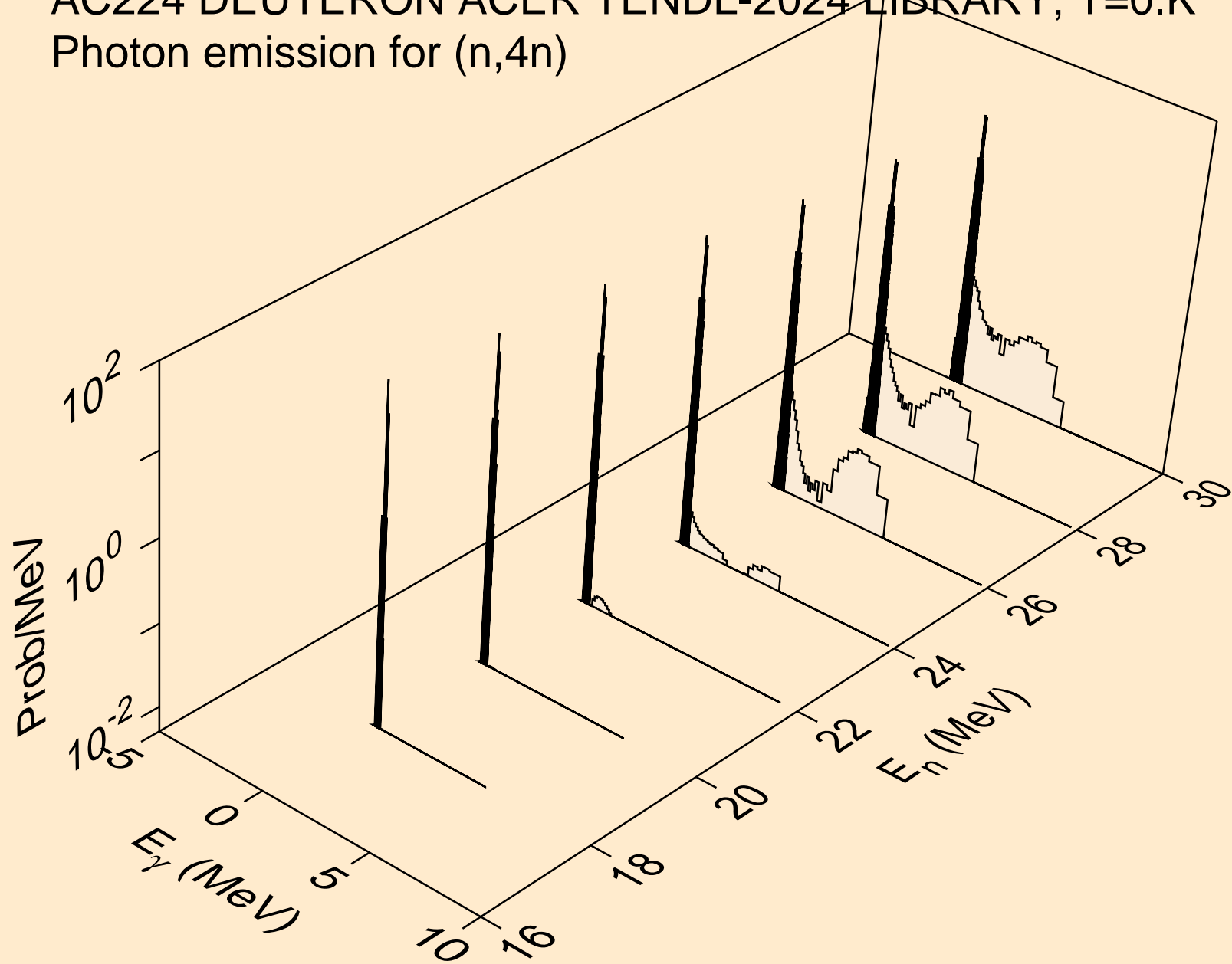

AC224 DEUTERON ACER TENDL-2024 LIBRARY; T=0.K  
Photon emission for (n,2np)

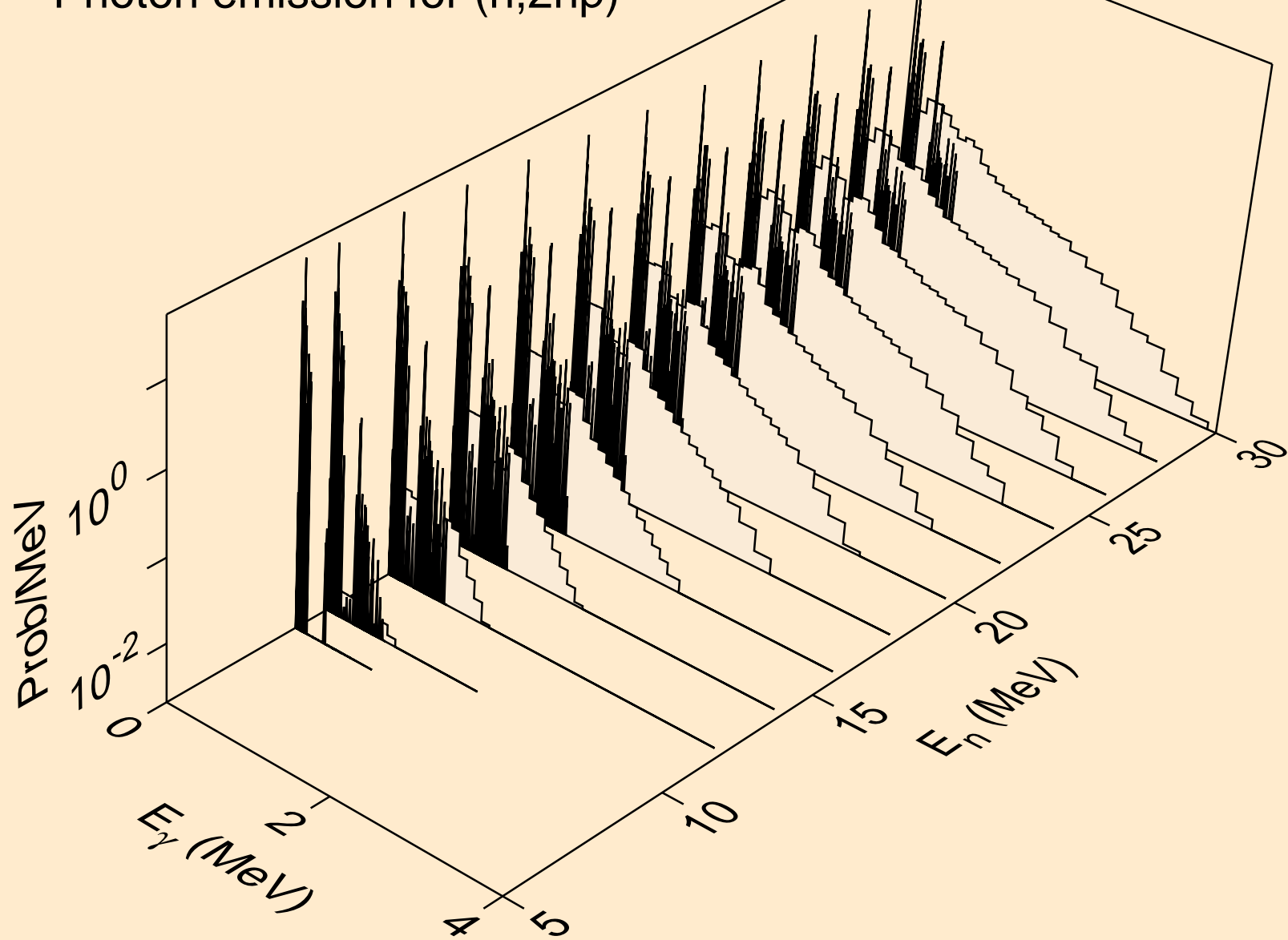

AC224 DEUTERON ACER TENDL-2024 LIBRARY; T=0.K  
Photon emission for (n,3np)

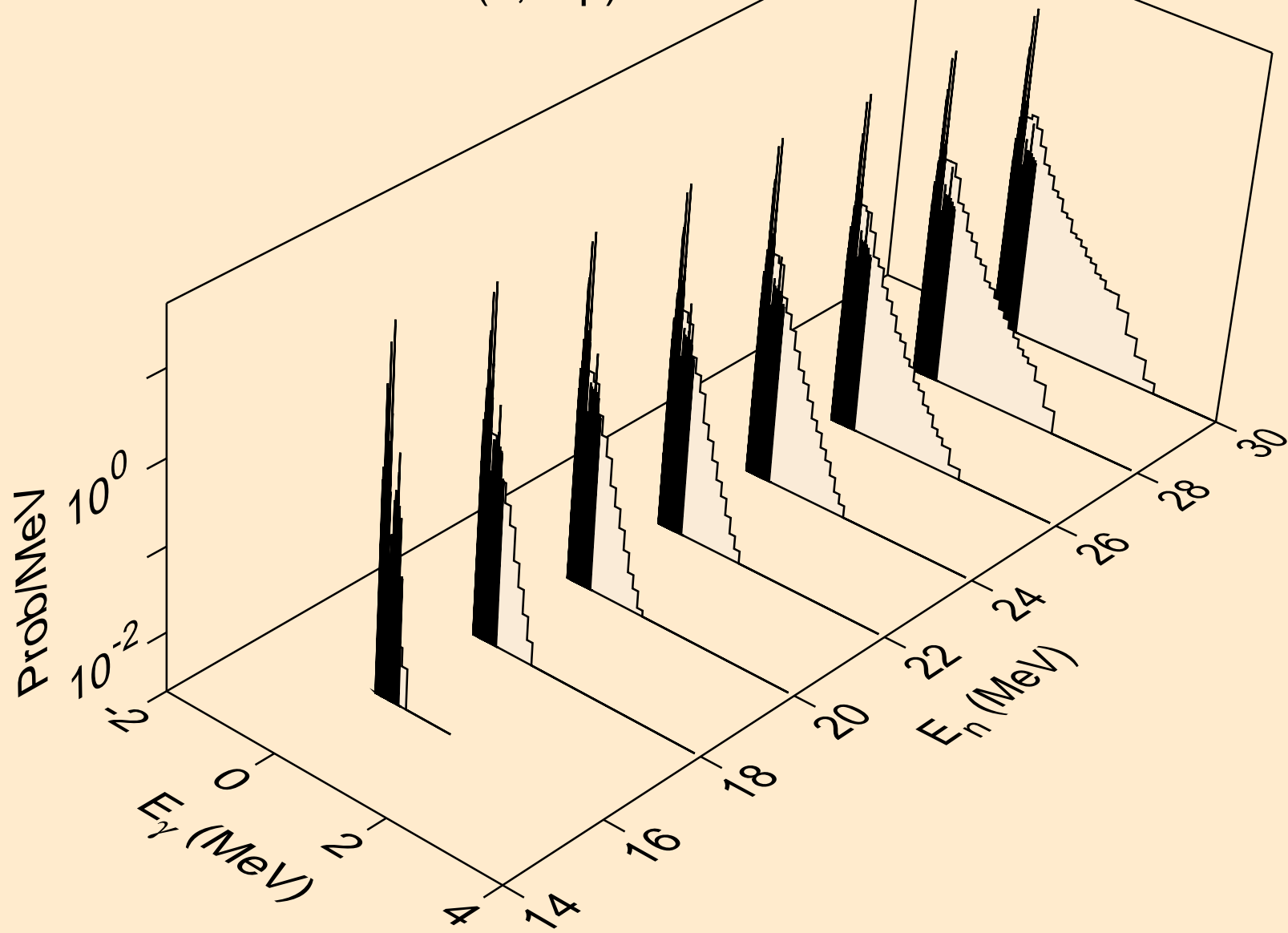

AC224 DEUTERON ACER TENDL-2024 LIBRARY; T=0.K  
Photon emission for (n,n2p)

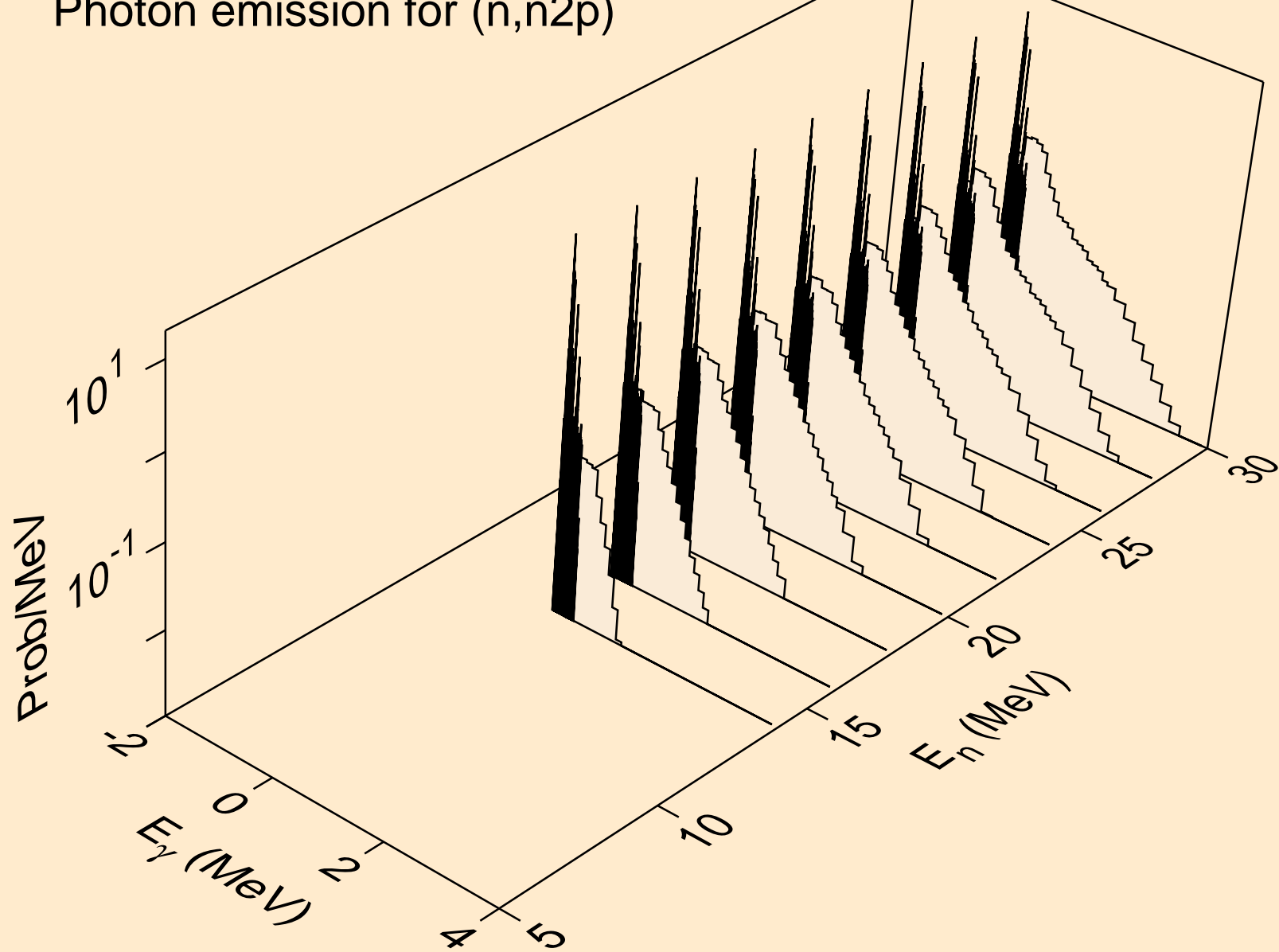

AC224 DEUTERON ACER TENDL-2024 LIBRARY; T=0.K  
Photon emission for (n,npa)

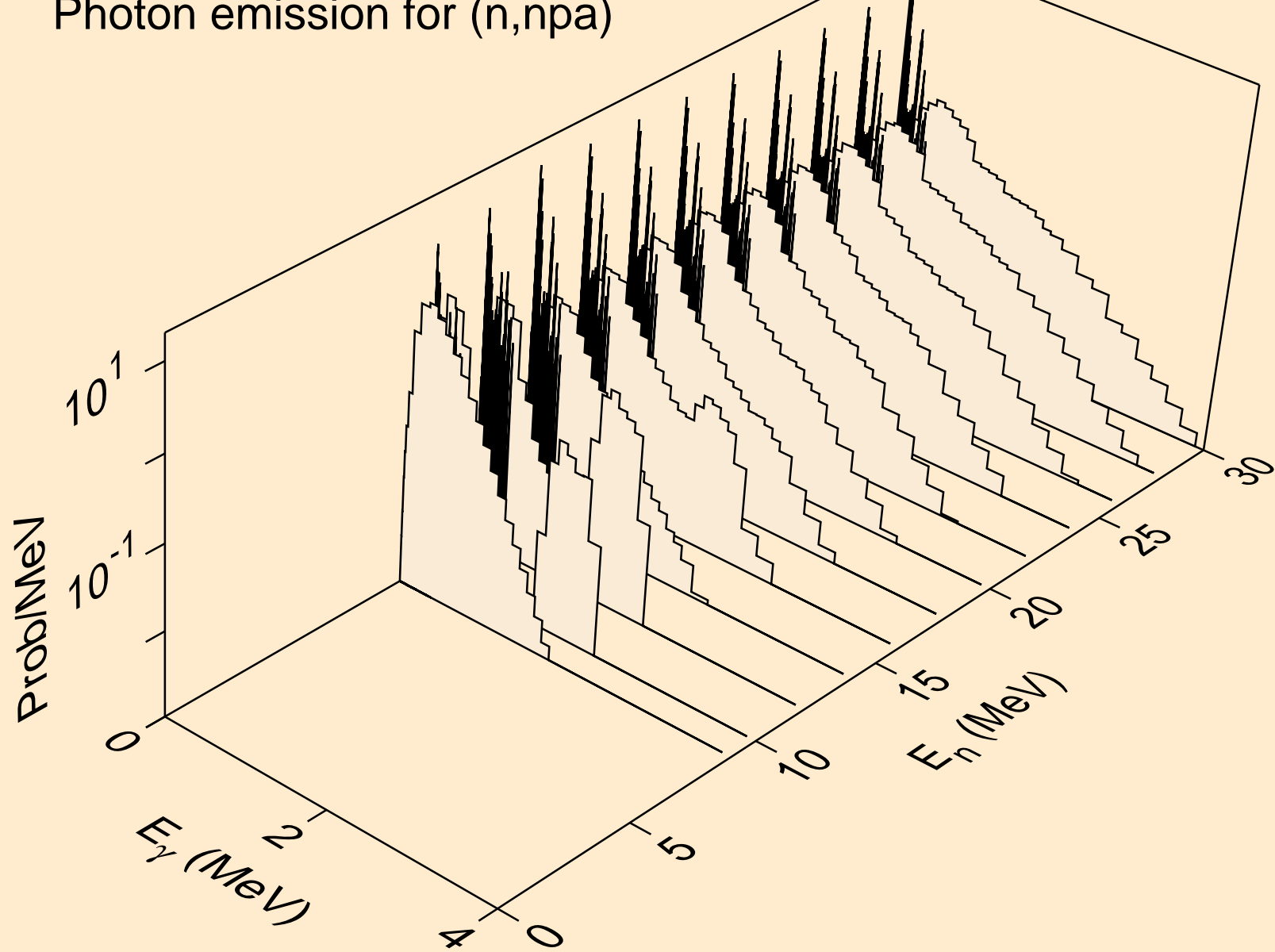

AC224 DEUTERON ACER TENDL-2024 LIBRARY; T=0.K  
Photon emission for (n,gma)

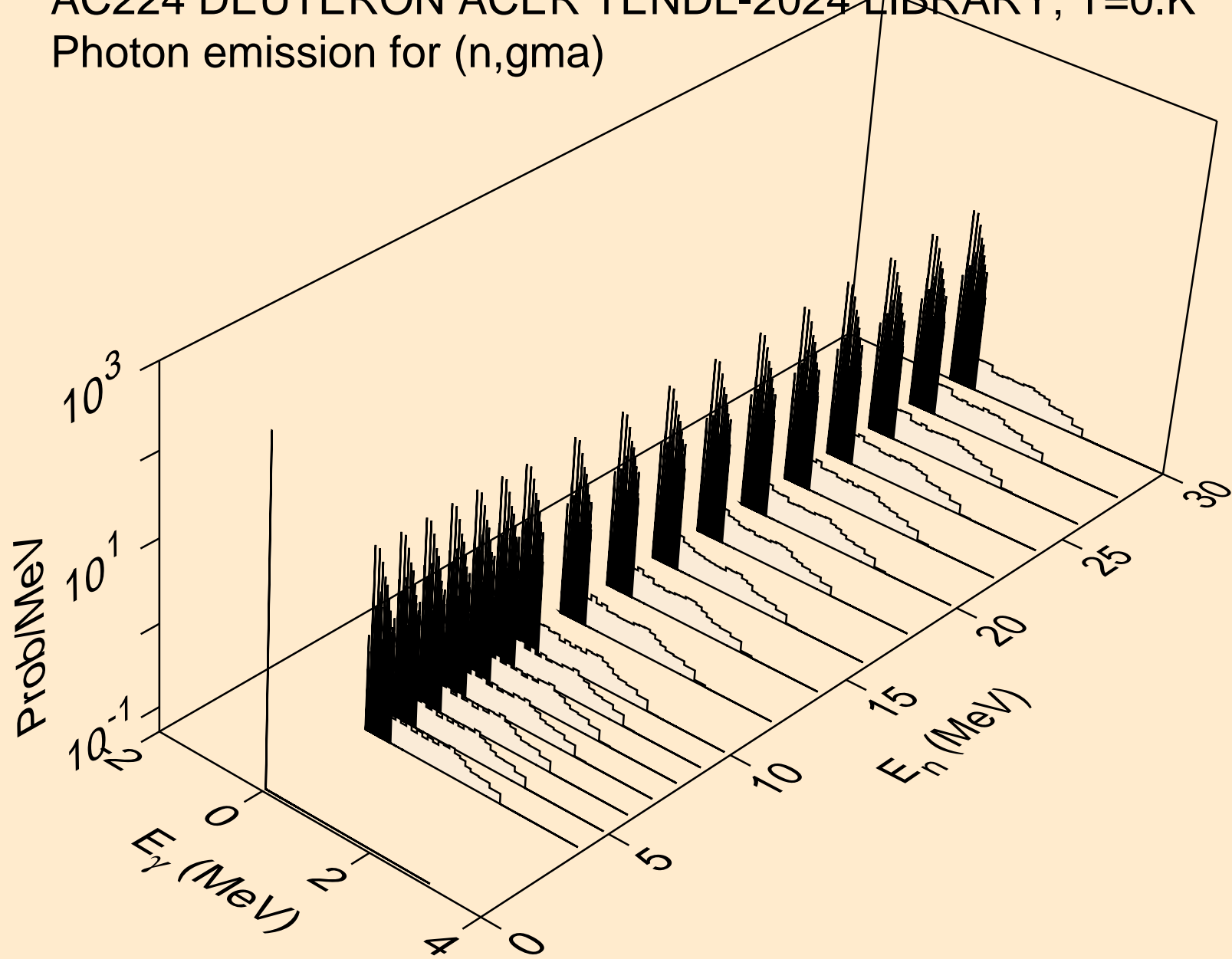

AC224 DEUTERON ACER TENDL-2024 LIBRARY; T=0.K  
Photon emission for (n,p)

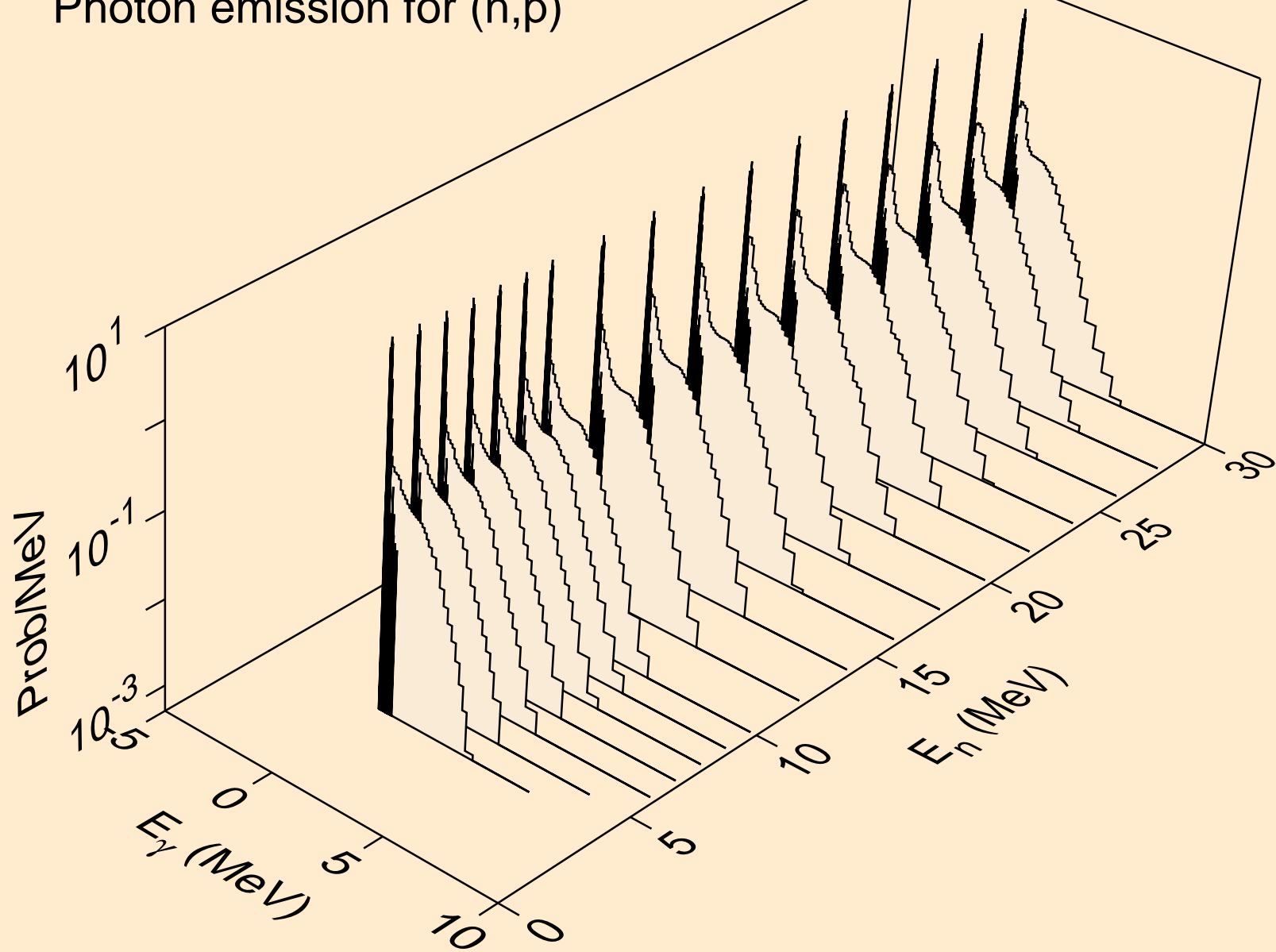

AC224 DEUTERON ACER TENDL-2024 LIBRARY; T=0.K  
Photon emission for inelastic

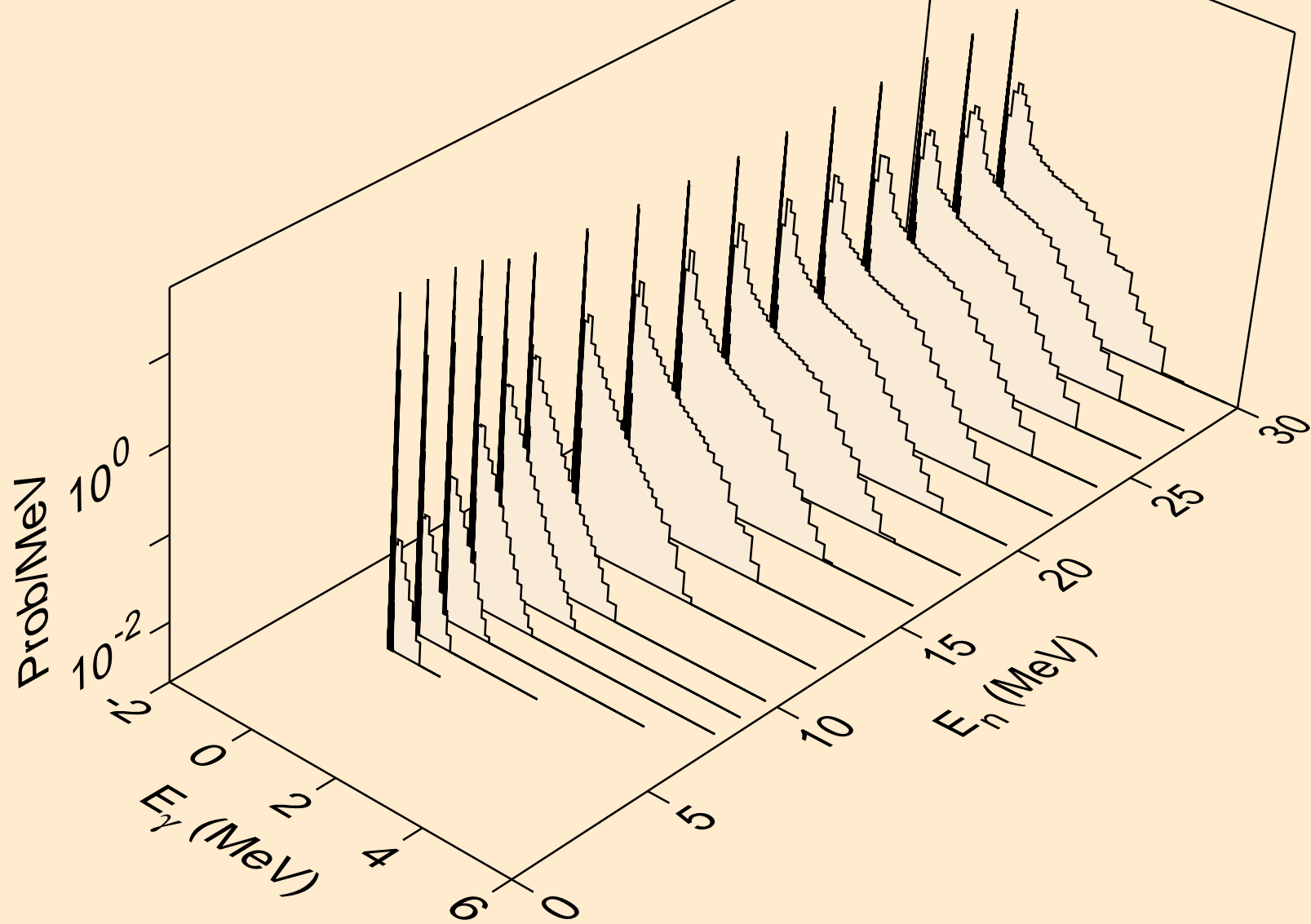

AC224 DEUTERON ACER TENDL-2024 LIBRARY; T=0.K  
Photon emission for (n,t)

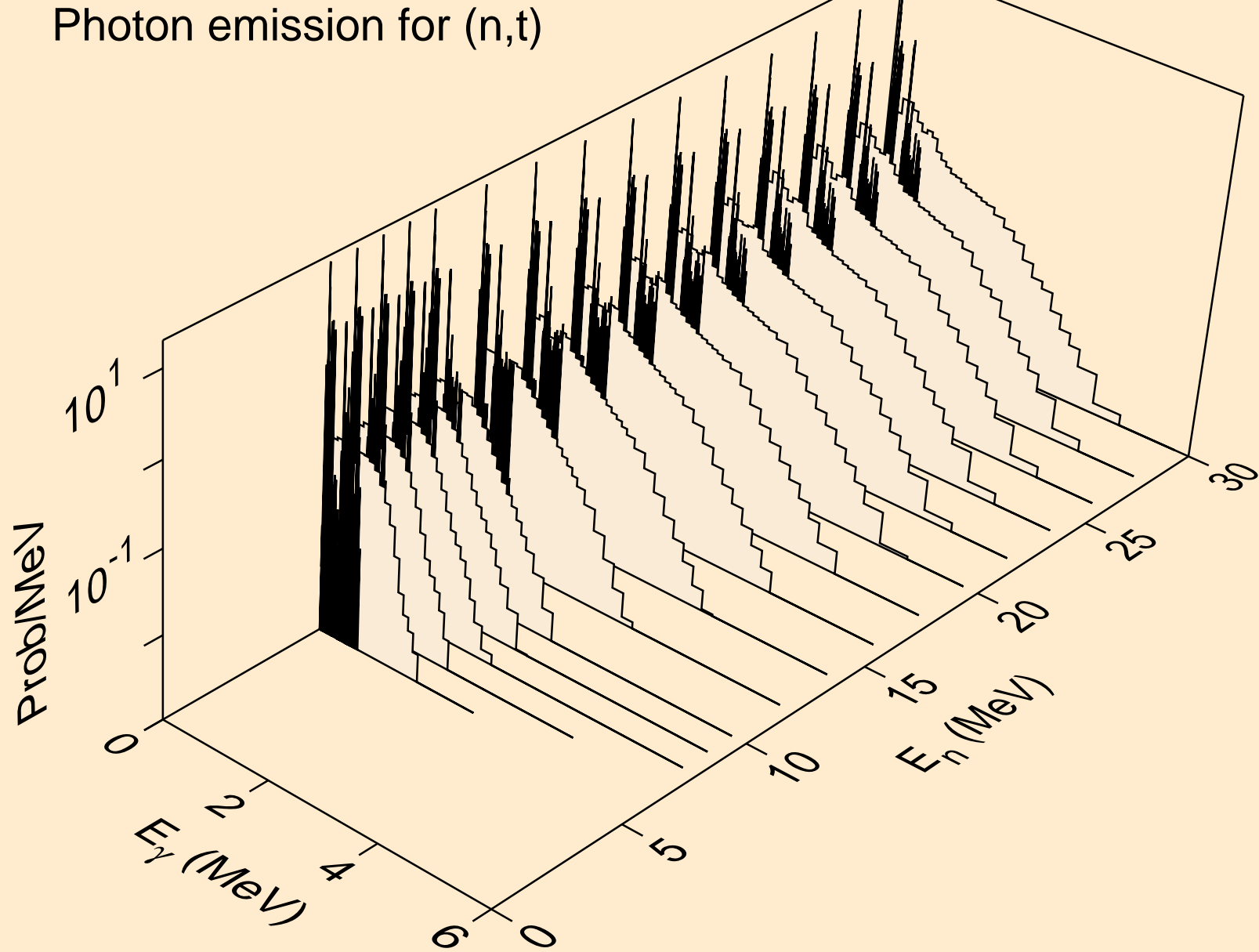

AC224 DEUTERON ACER TENDL-2024 LIBRARY; T=0.K  
Photon emission for (n,he3)

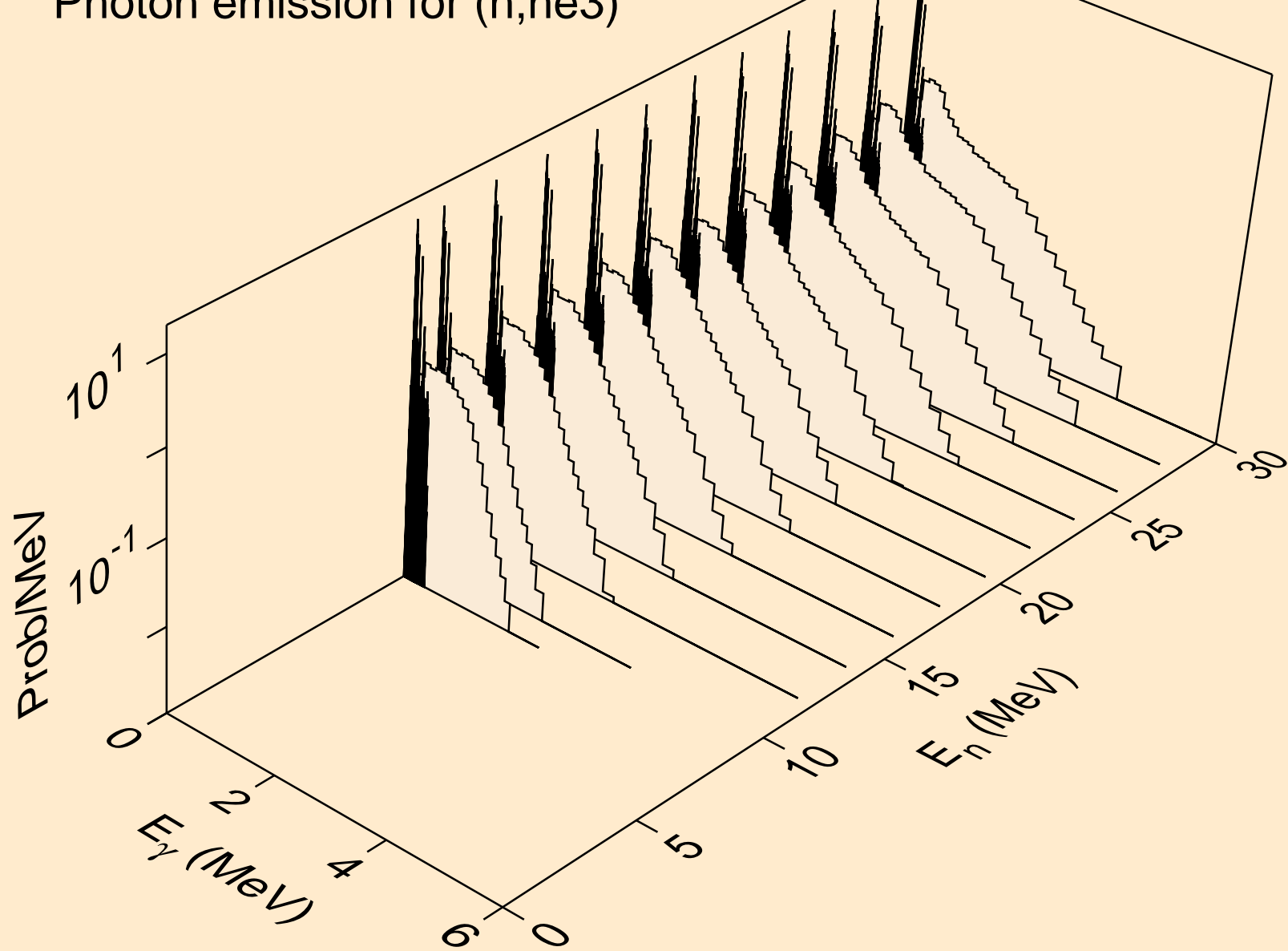

AC224 DEUTERON ACER TENDL-2024 LIBRARY; T=0.K  
Photon emission for (n,a)

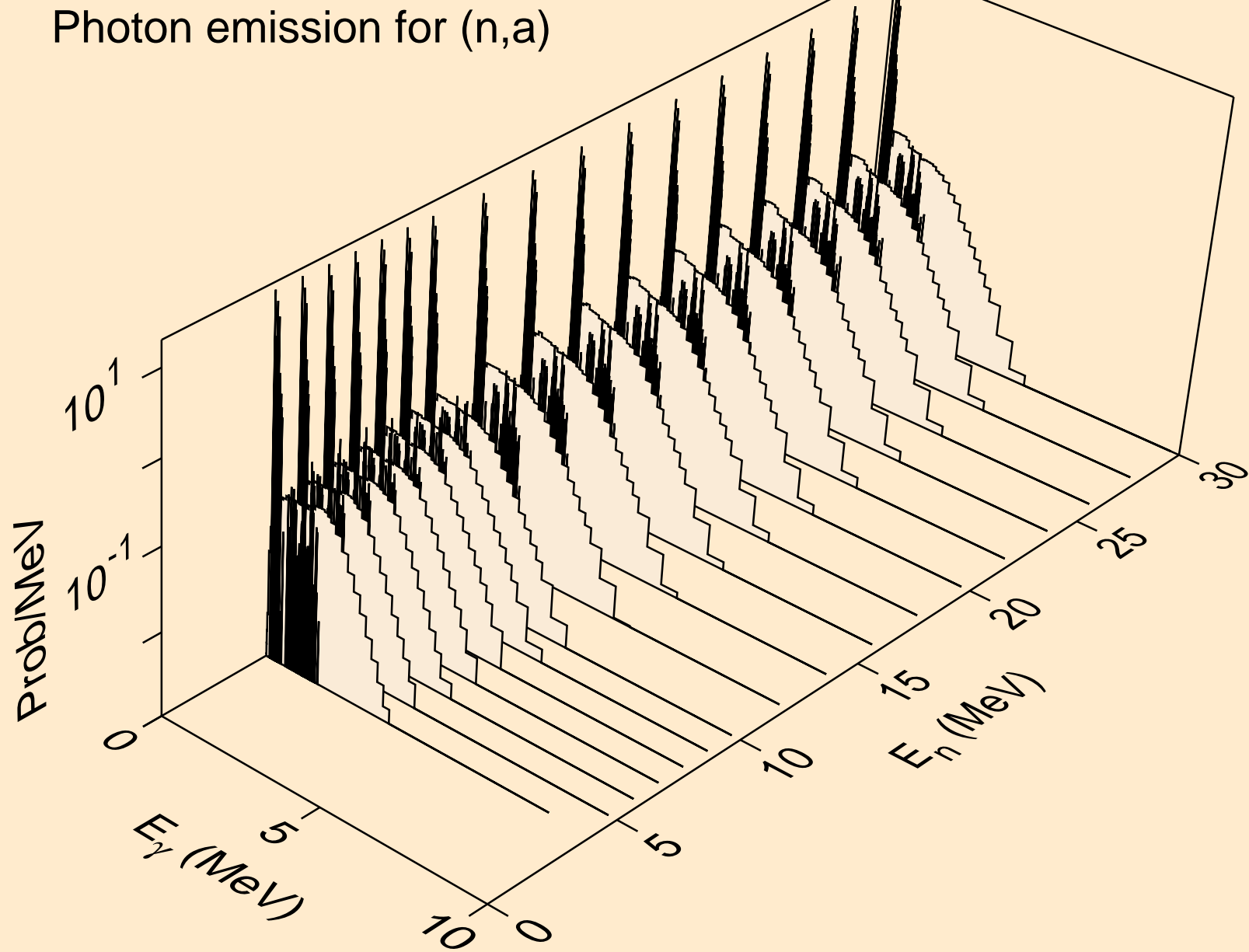

AC224 DEUTERON ACER TENDL-2024 LIBRARY; T=0.K  
Photon emission for (n,2a)

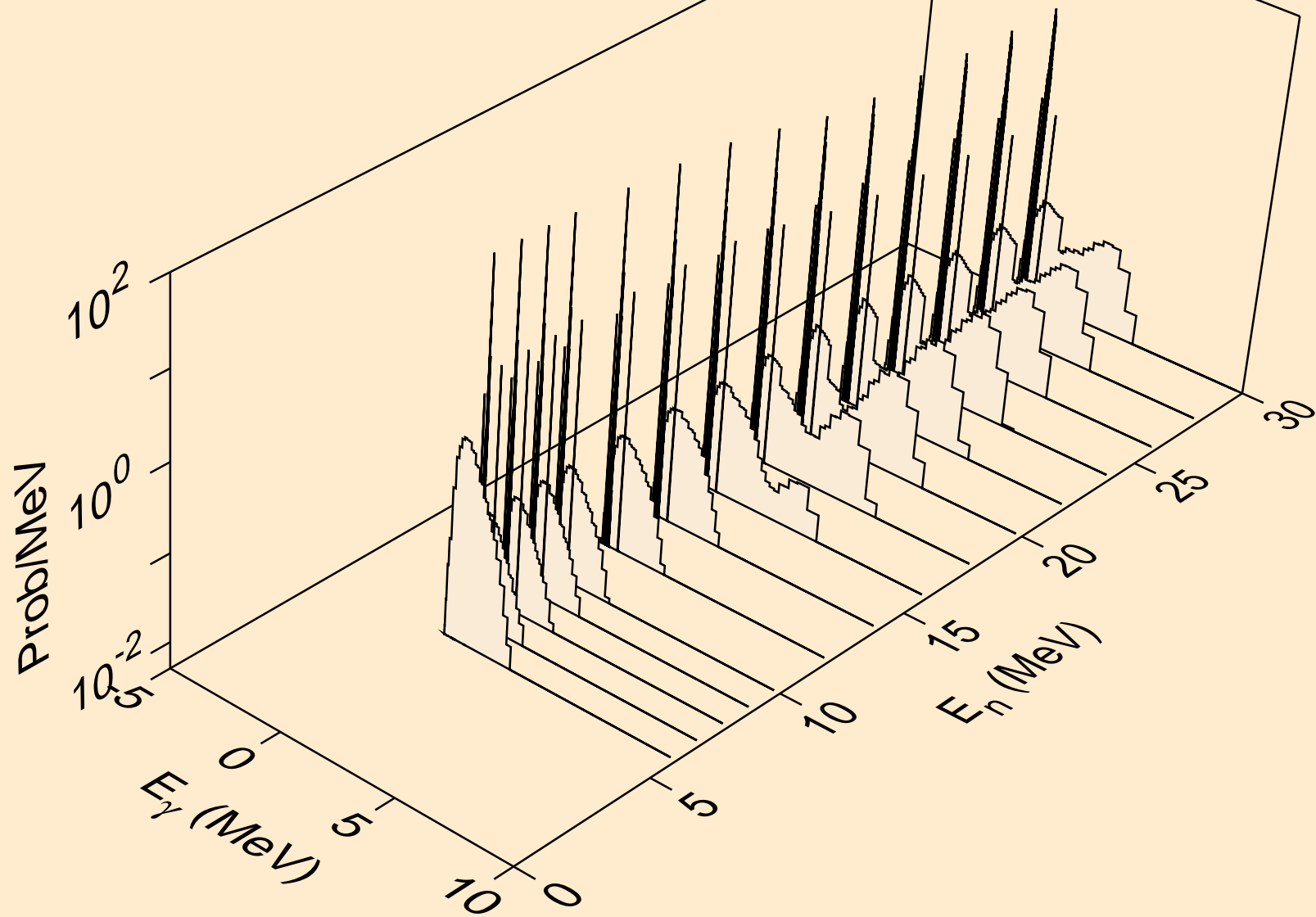

AC224 DEUTERON ACER TENDL-2024 LIBRARY; T=0.K  
Photon emission for (n,2p)

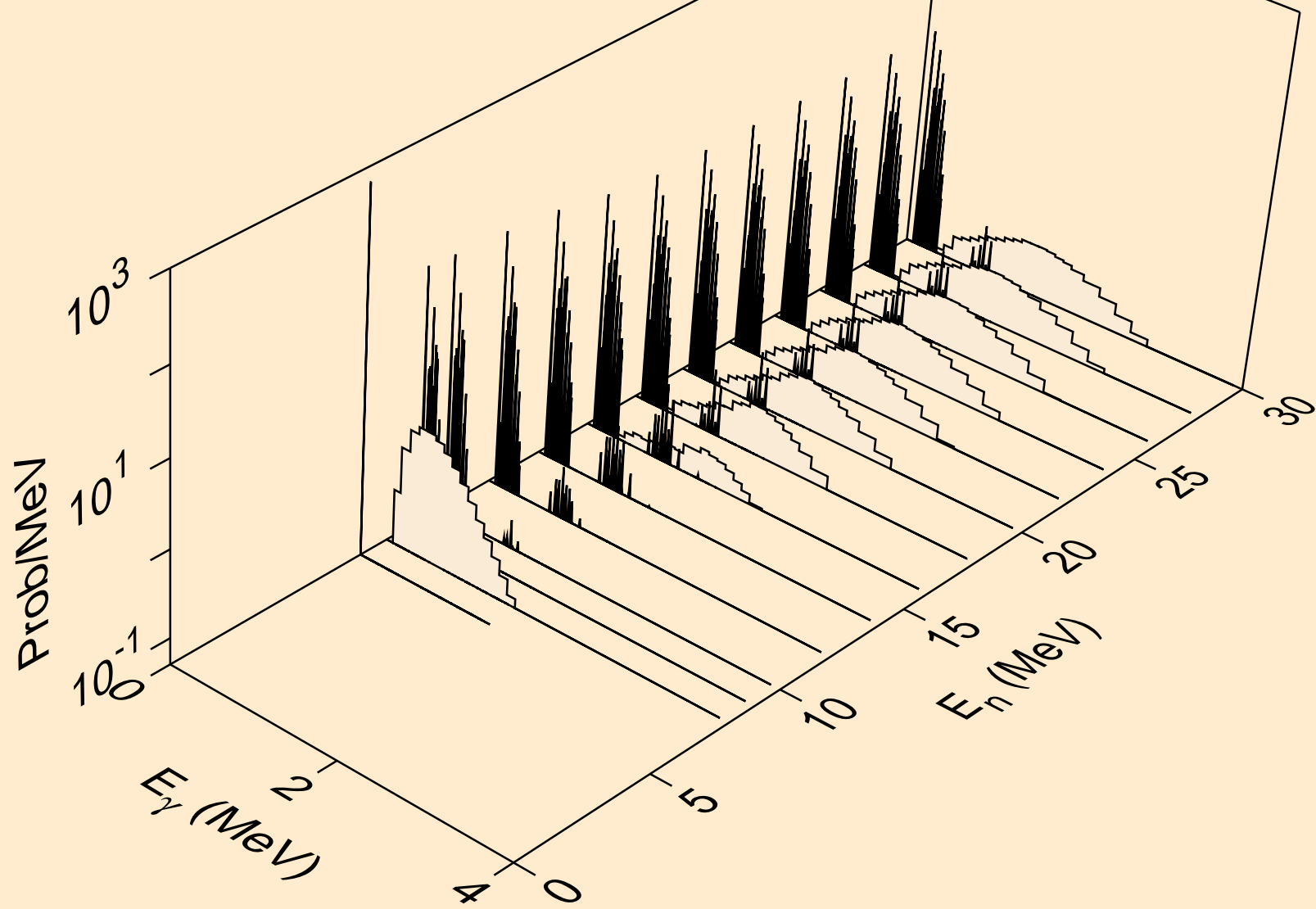

AC224 DEUTERON ACER TENDL-2024 LIBRARY; T=0.K  
Photon emission for (n,p)

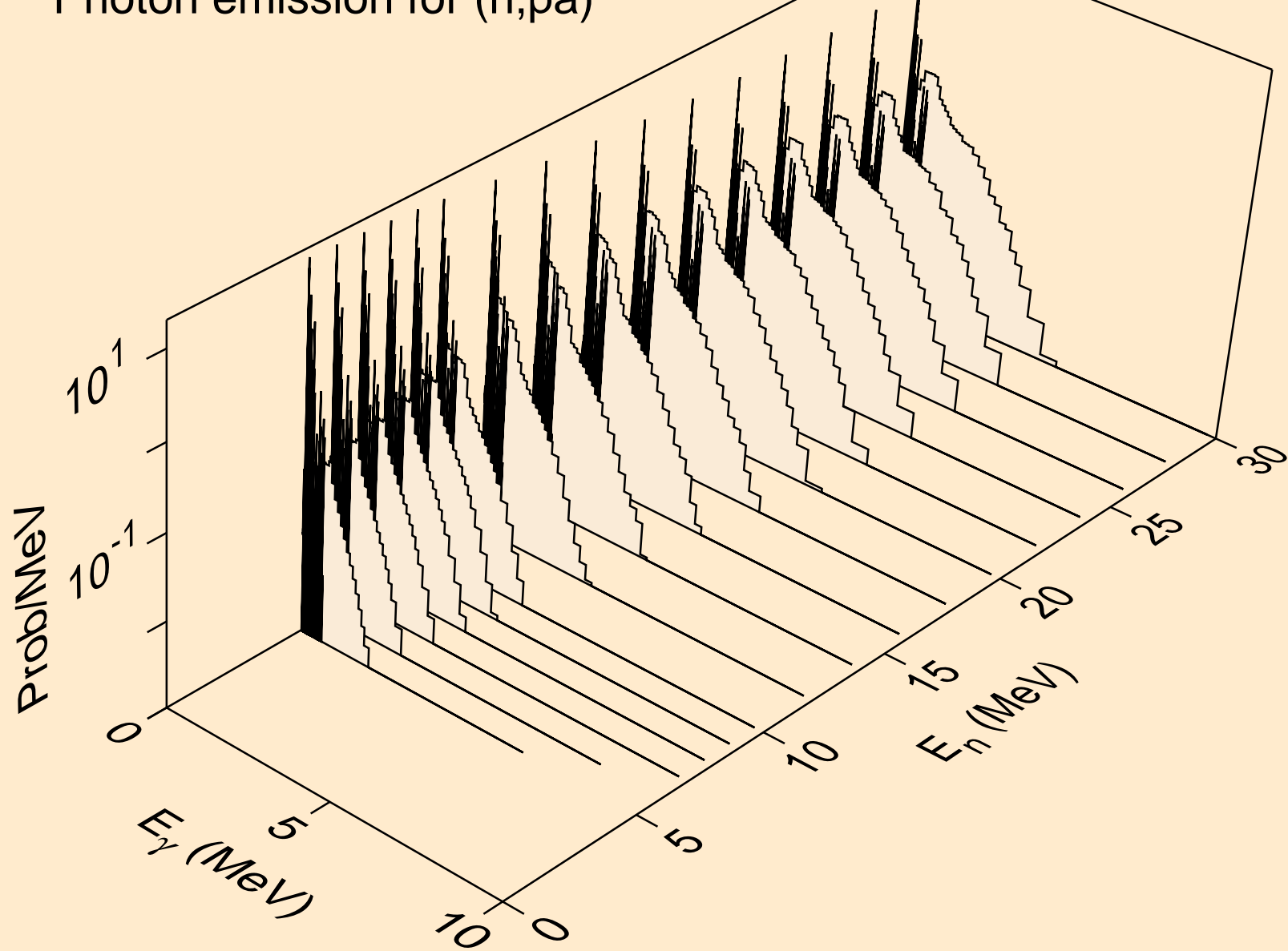

AC224 DEUTERON ACER TENDL-2024 LIBRARY; T=0.K  
Photon emission for (n,pd)

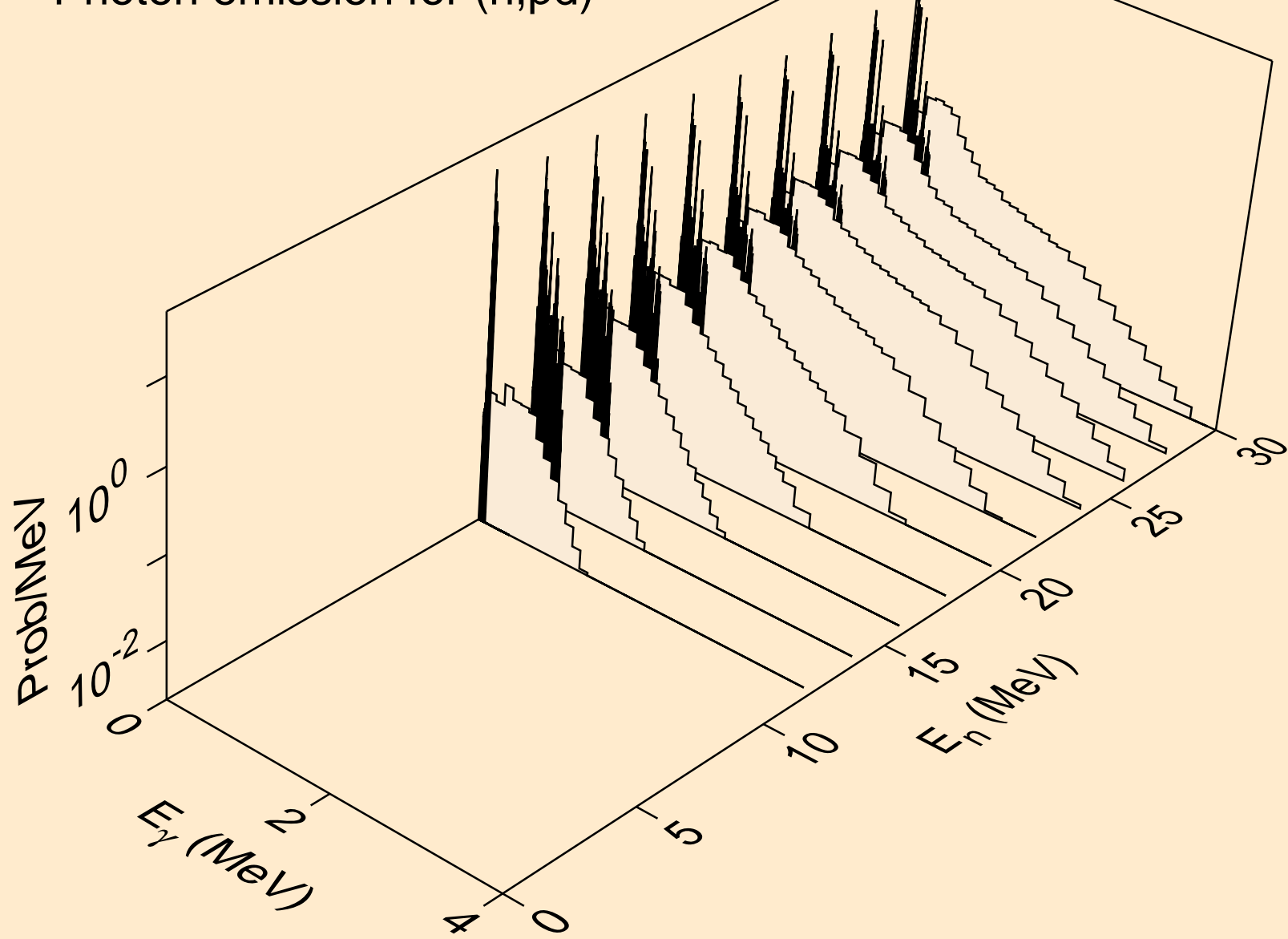

AC224 DEUTERON ACER TENDL-2024 LIBRARY; T=0.K  
Photon emission for (n,pt)

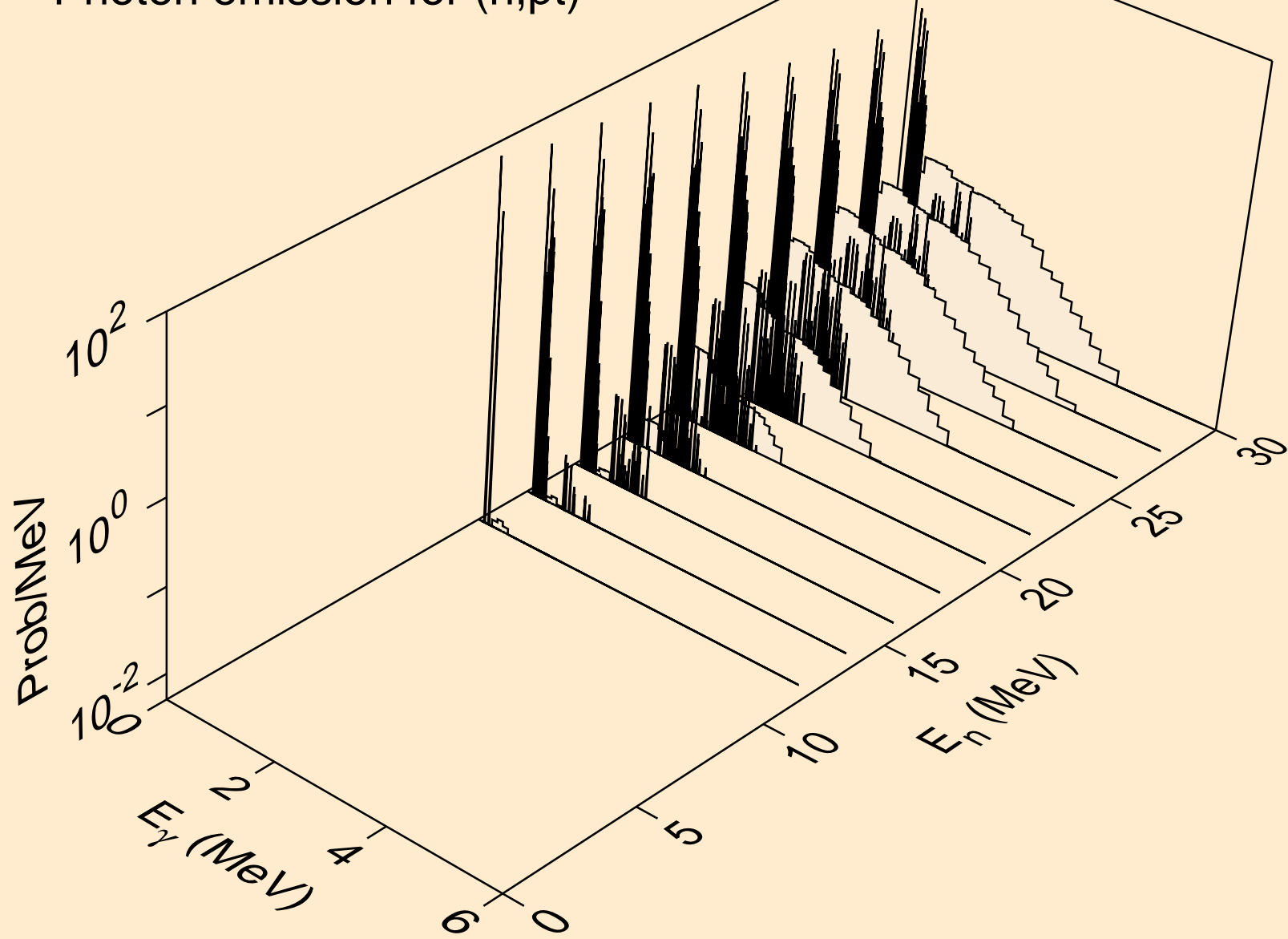

AC224 DEUTERON ACER TENDL-2024 LIBRARY; T=0.K  
Photon emission for (n,da)

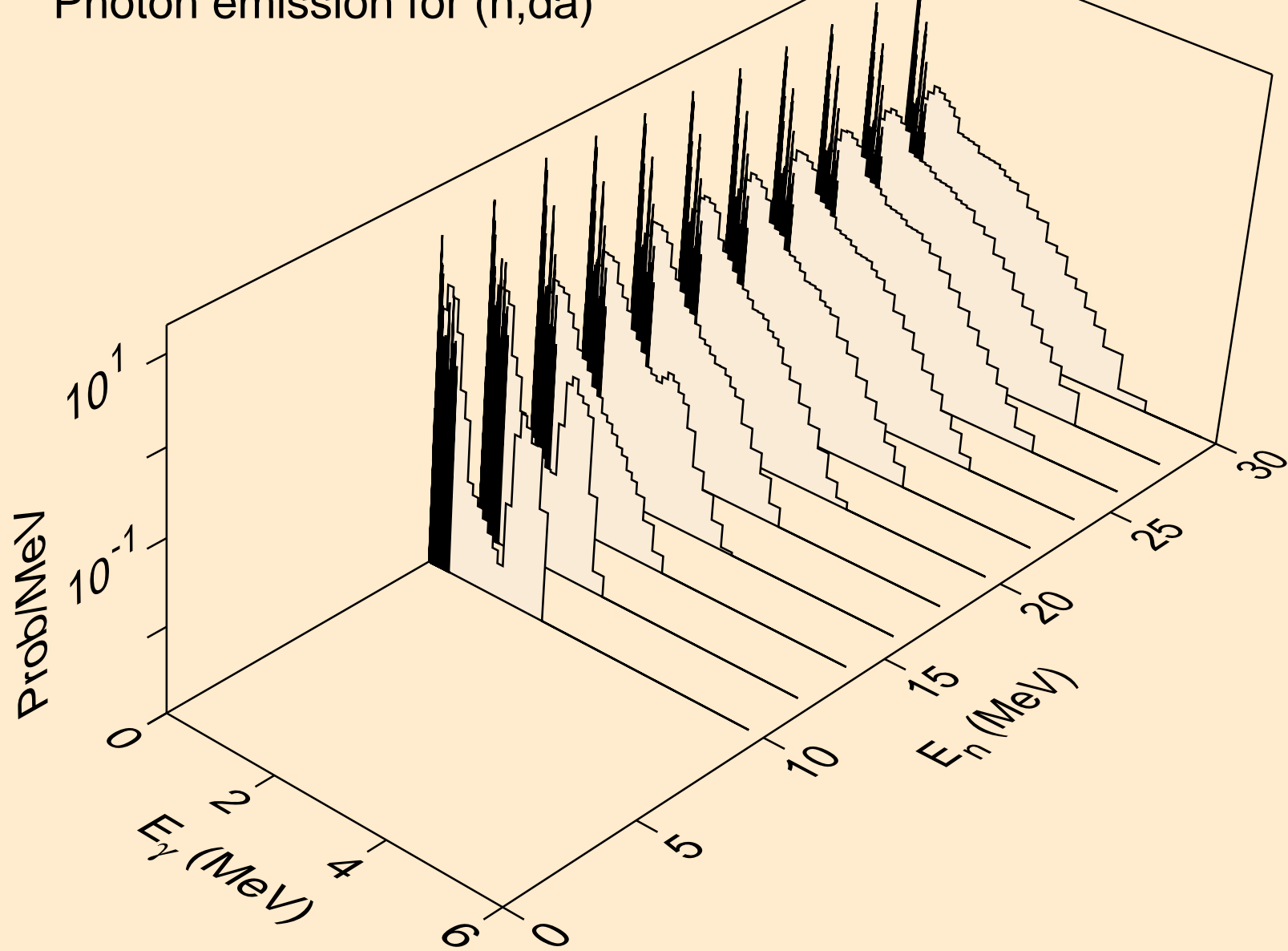

AC224 DEUTERON ACER TENDL-2024 LIBRARY; T=0.K  
Particle heating contributions

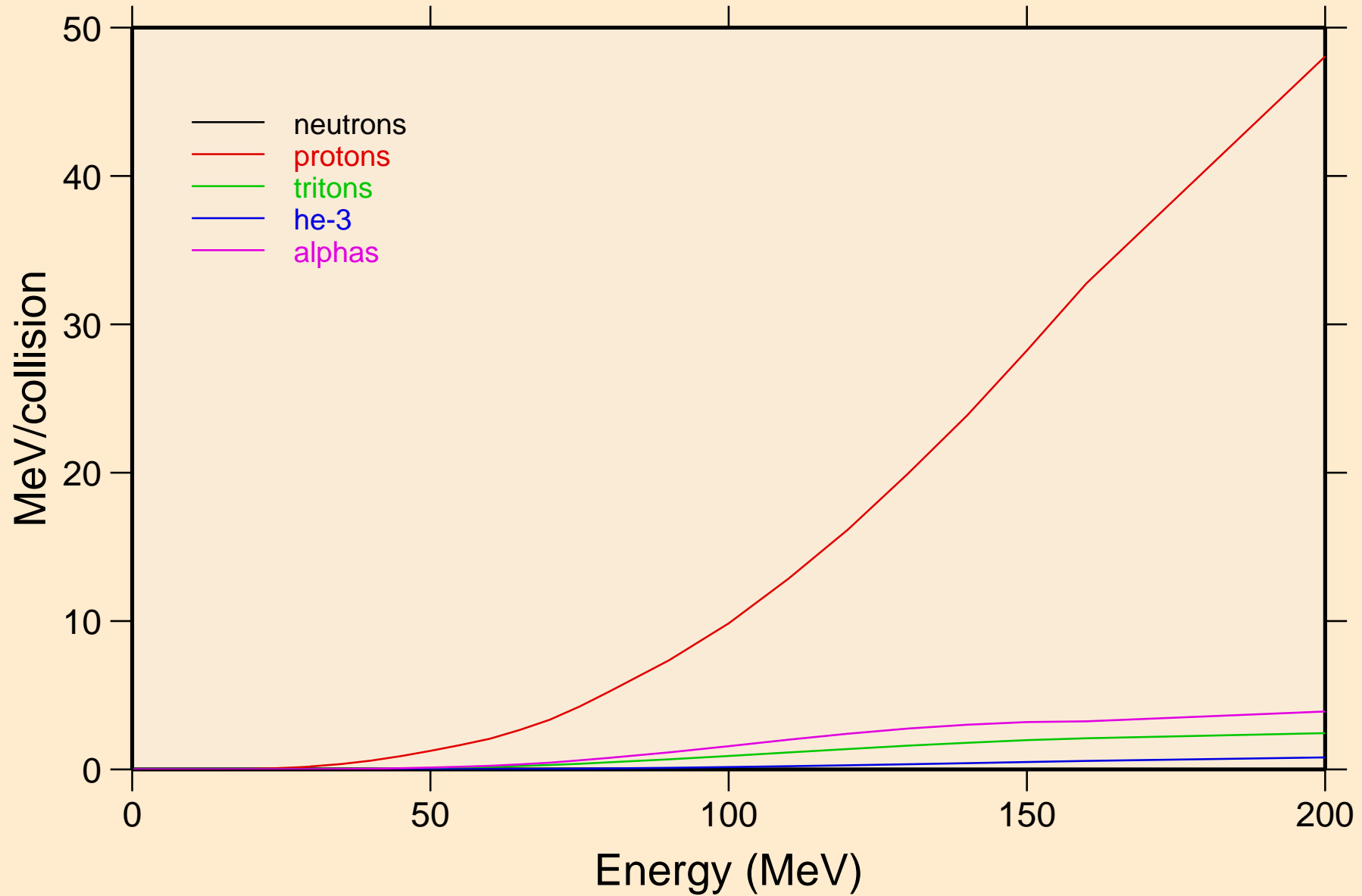

AC224 DEUTERON ACER TENDL-2024 LIBRARY; T=0.K  
Recoil Heating

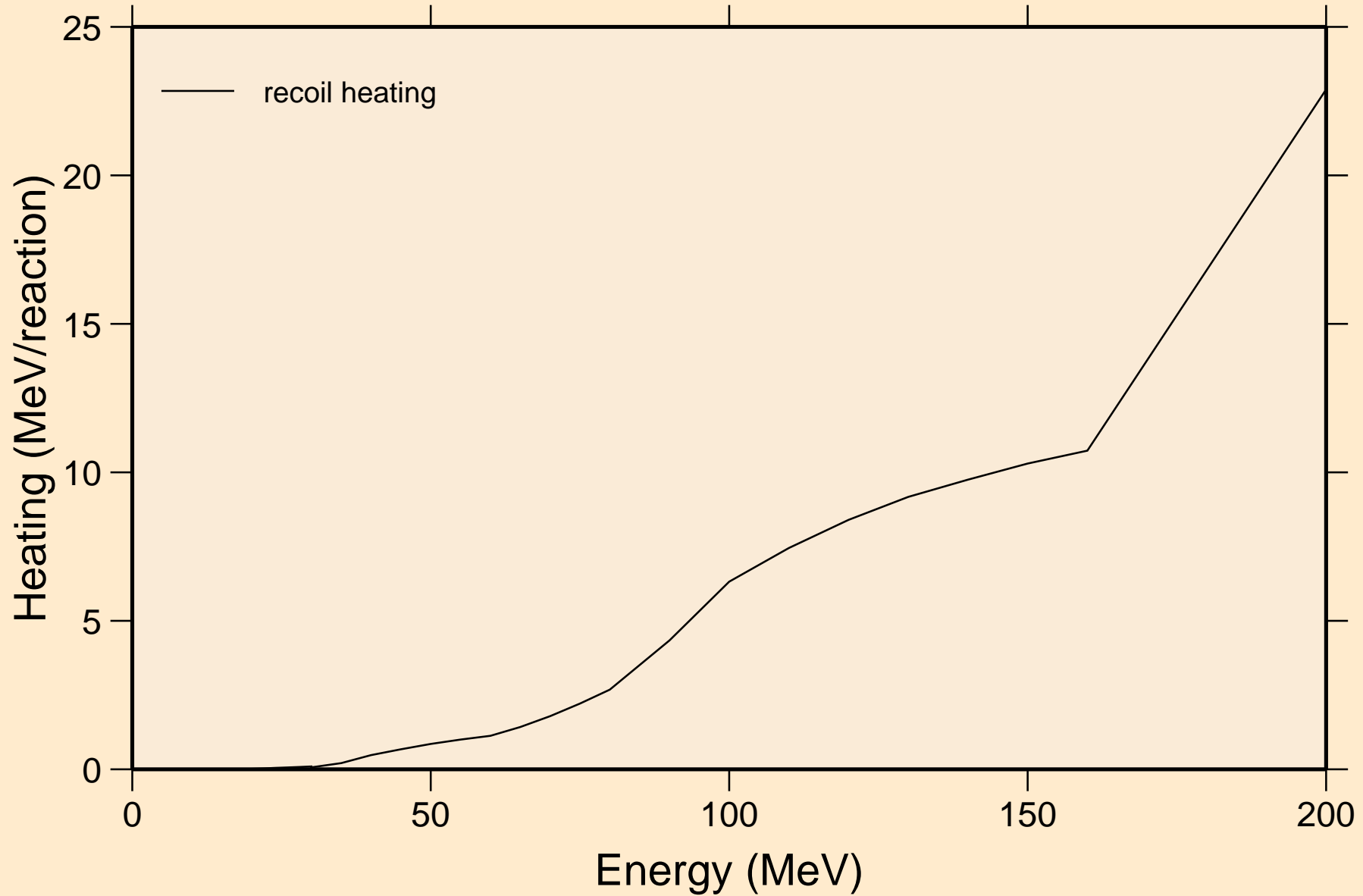

AC224 DEUTERON ACER TENDL-2024 LIBRARY; T=0.K  
Particle production cross sections

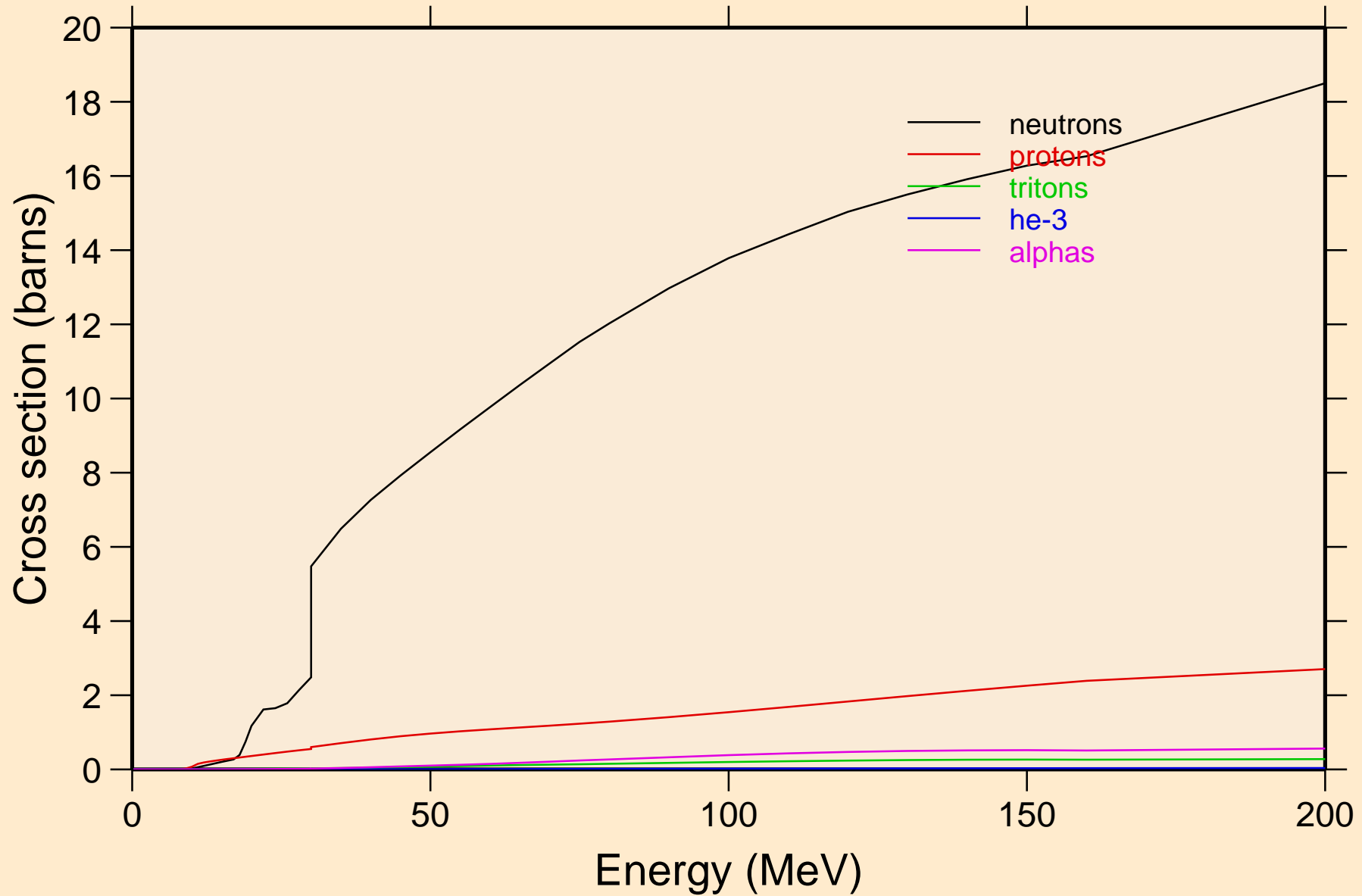

AC224 DEUTERON ACER TENDL-2024 LIBRARY; T=0.K  
neutrons from (d,n)

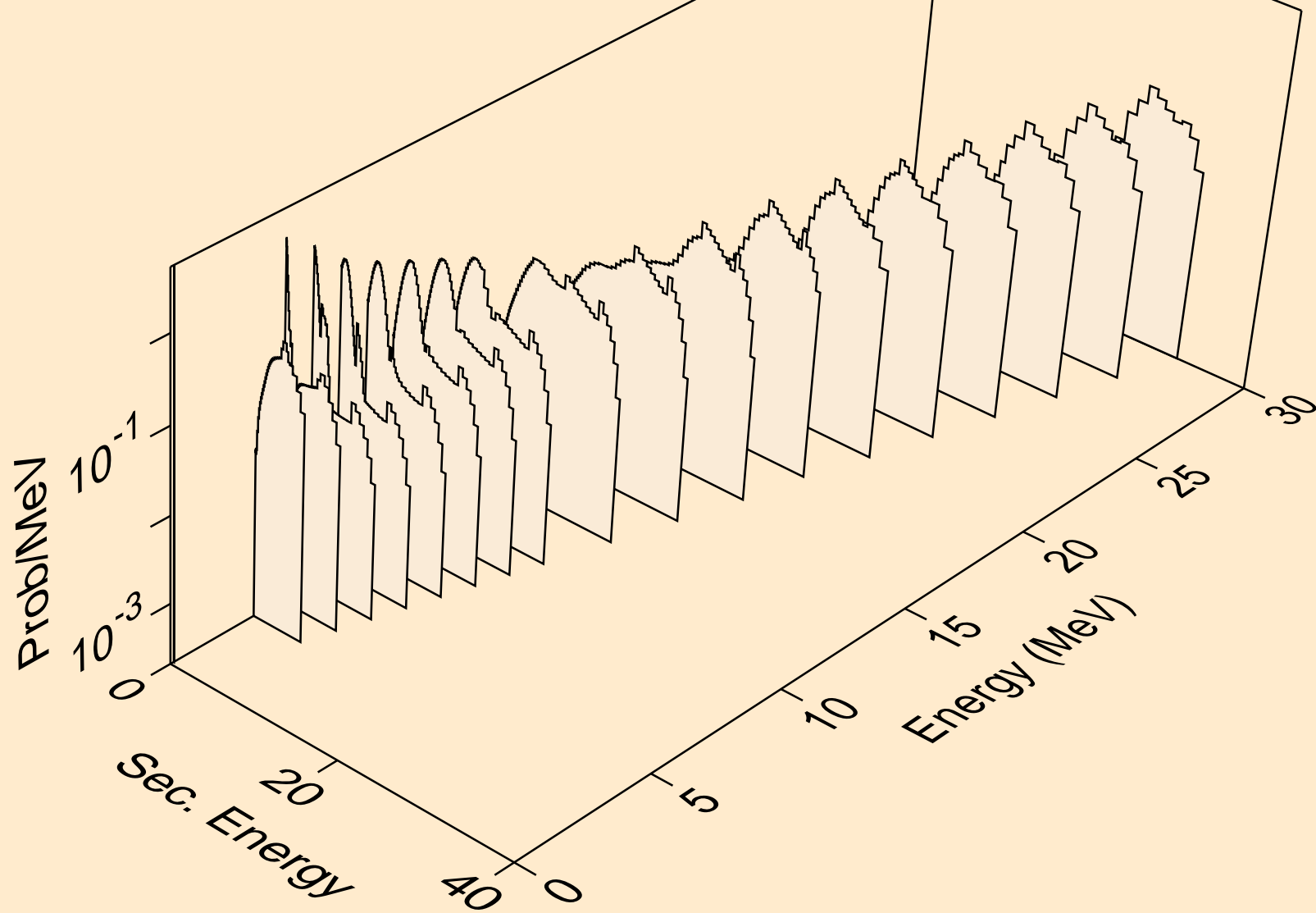

AC224 DEUTERON ACER TENDL-2024 LIBRARY; T=0.K  
neutrons from (d,x)

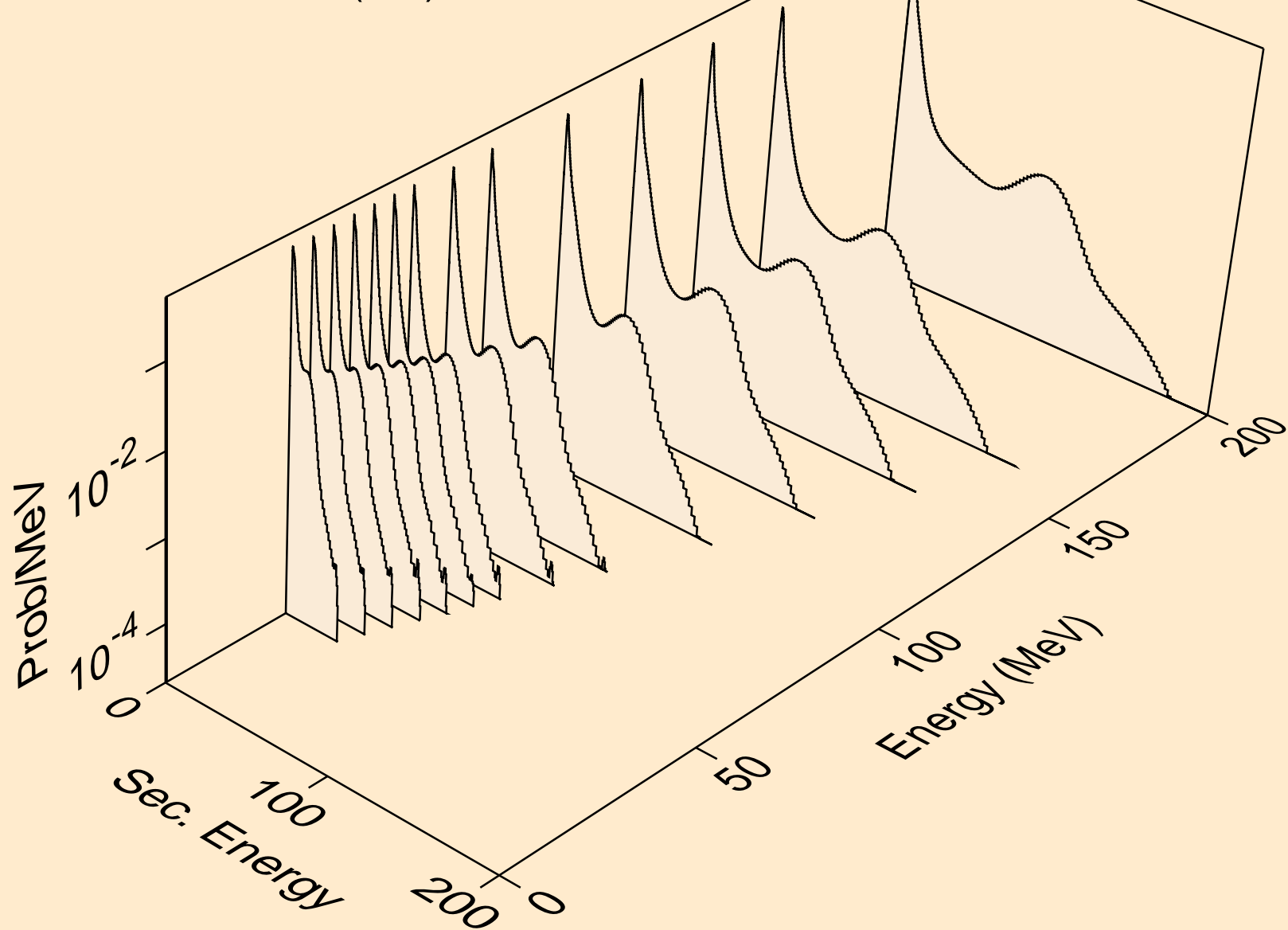

AC224 DEUTERON ACER TENDL-2024 LIBRARY; T=0.K  
neutrons from (d,2nd)

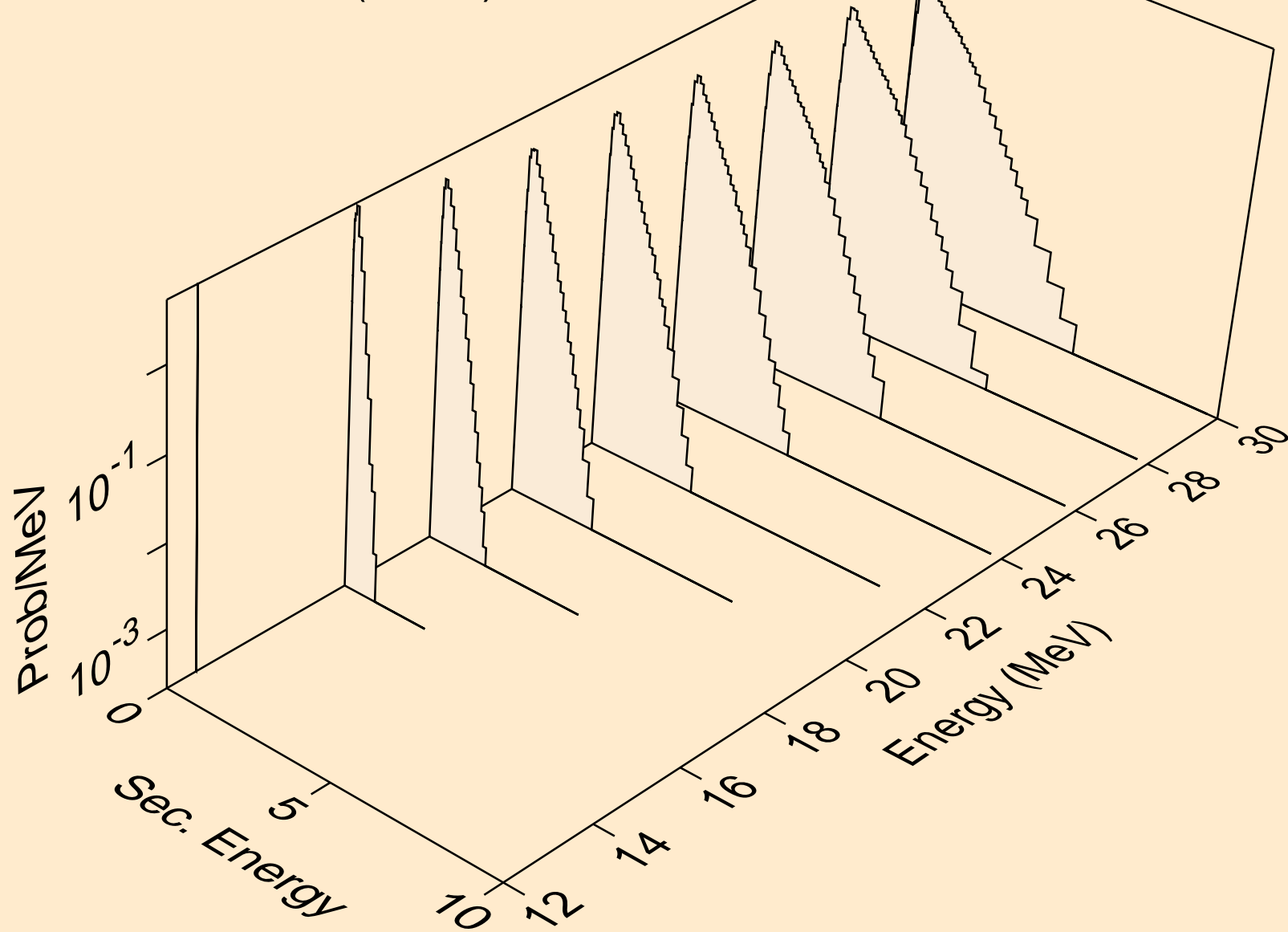

AC224 DEUTERON ACER TENDL-2024 LIBRARY; T=0.K  
neutrons from (d,2n)

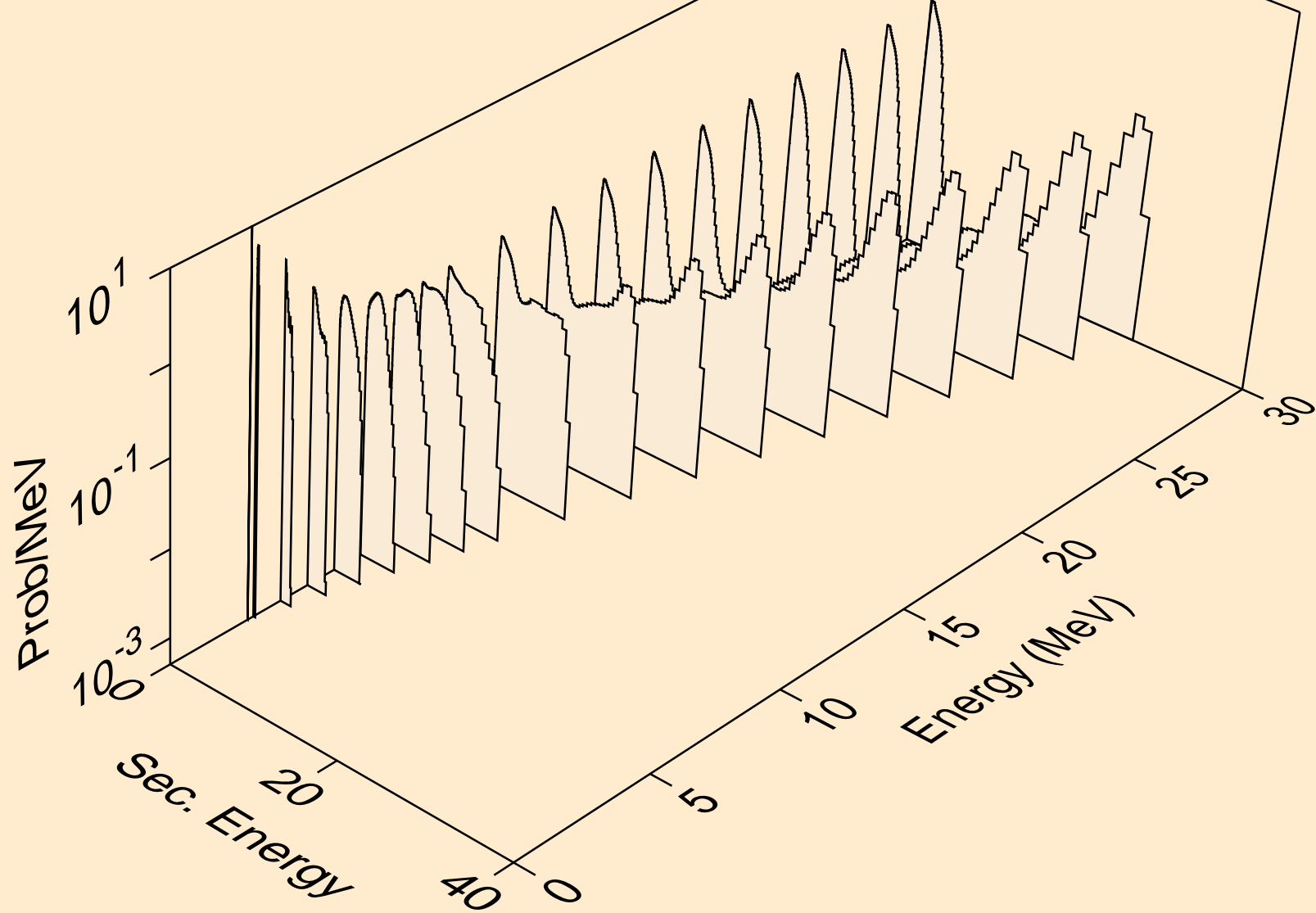

AC224 DEUTERON ACER TENDL-2024 LIBRARY; T=0.K  
neutrons from (d,3n)

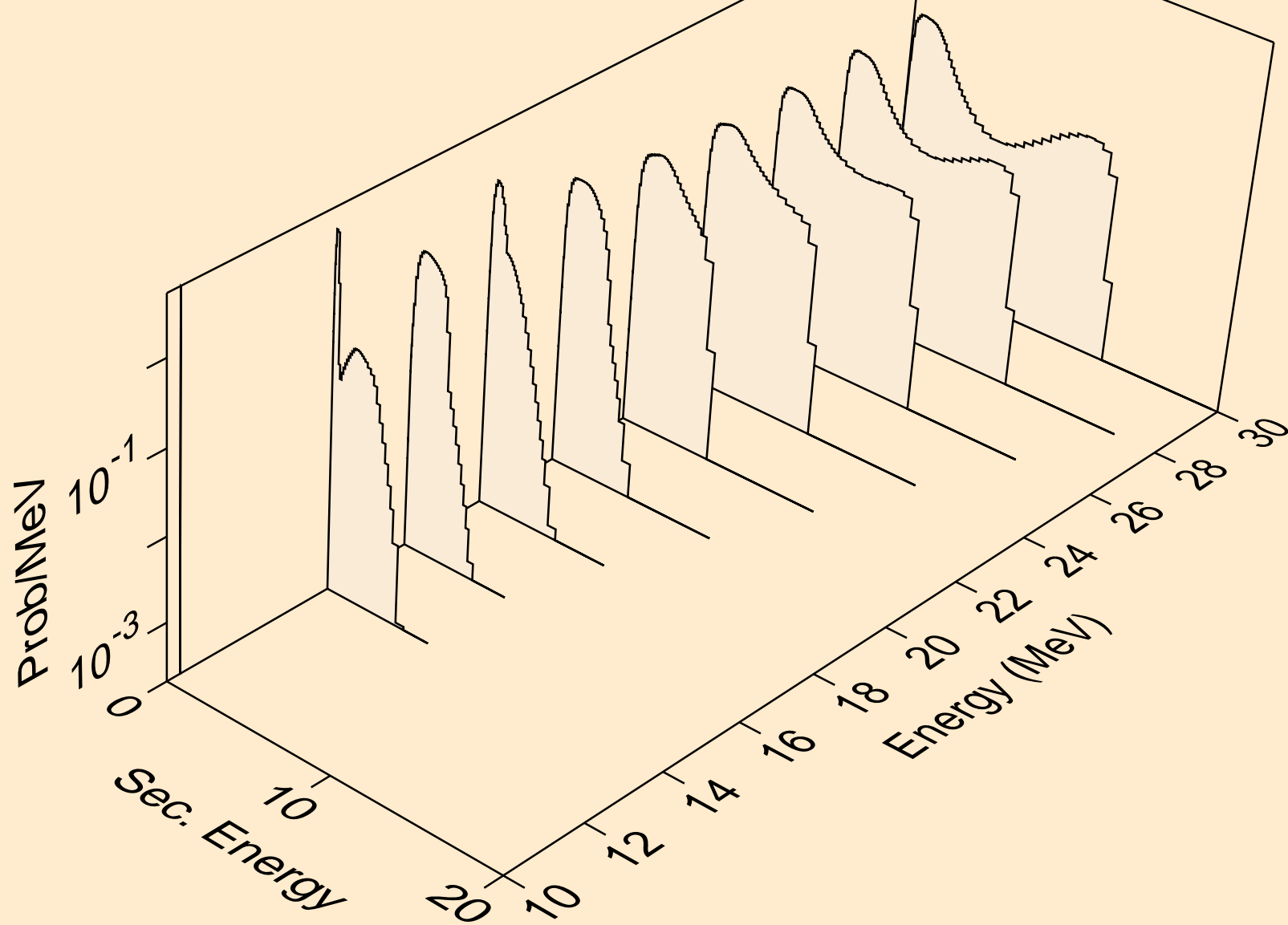

AC224 DEUTERON ACER TENDL-2024 LIBRARY; T=0.K  
neutrons from (d,n\*)a

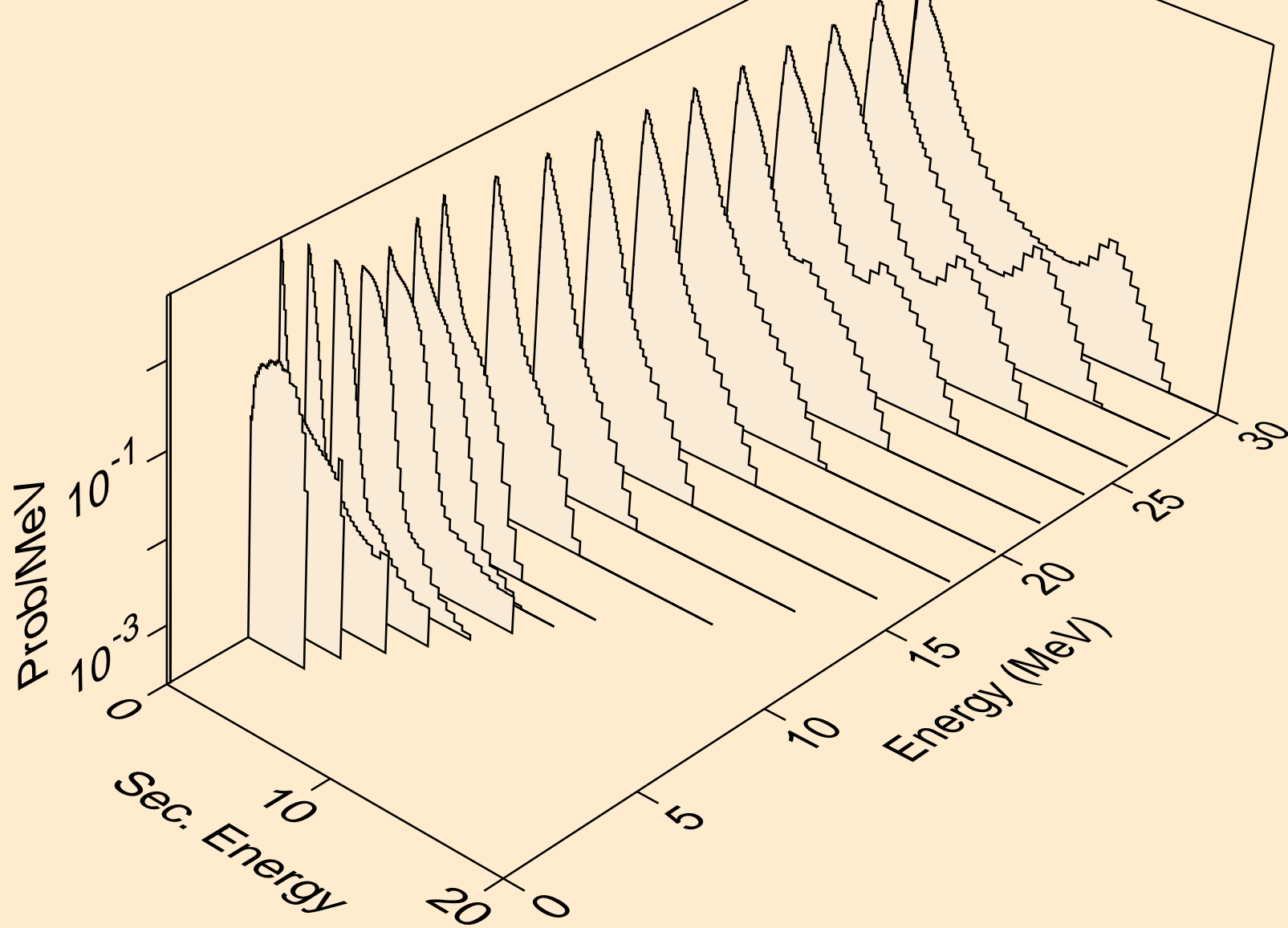

AC224 DEUTERON ACER TENDL-2024 LIBRARY; T=0.K  
neutrons from (d,2n)a

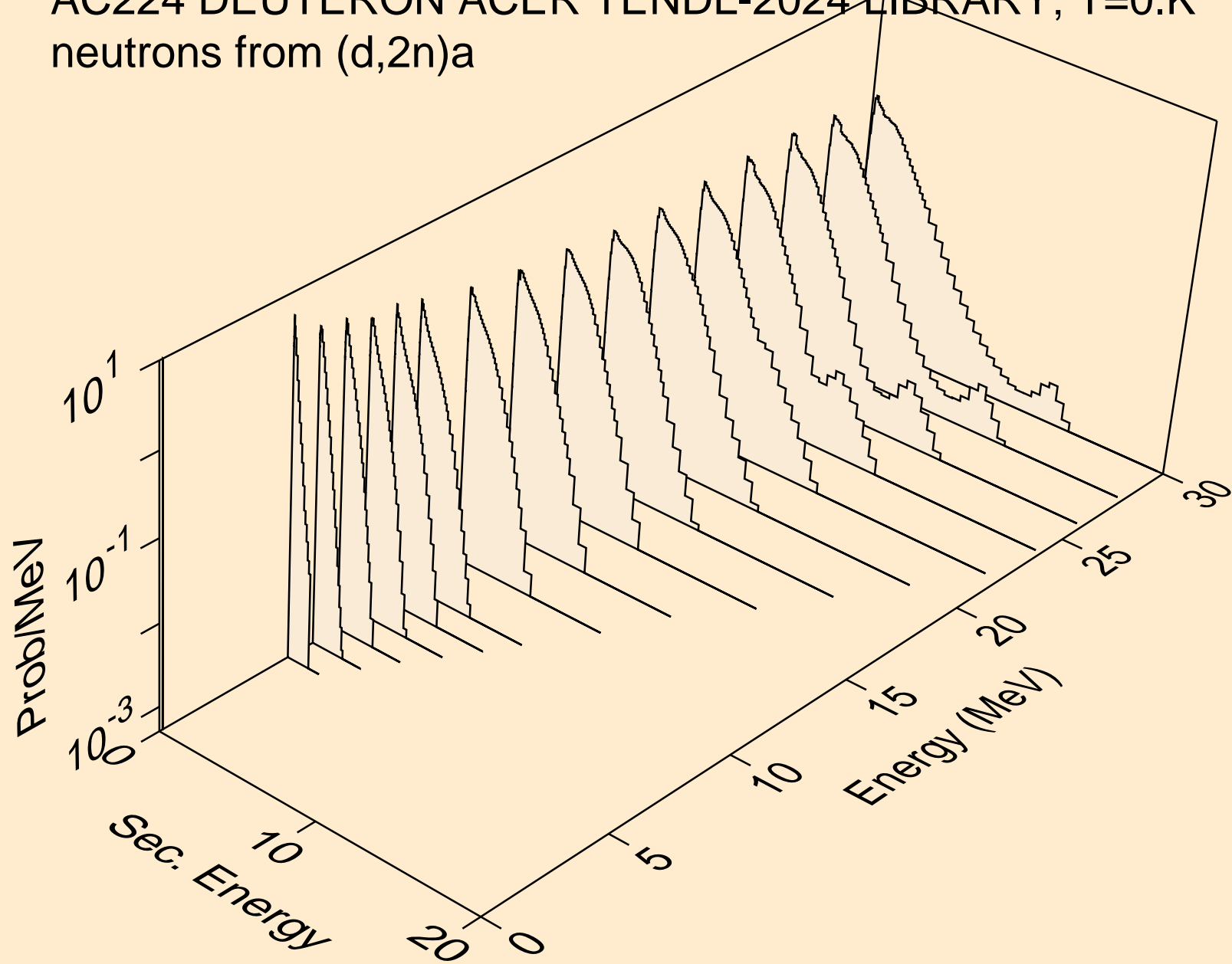

AC224 DEUTERON ACER TENDL-2024 LIBRARY; T=0.K  
neutrons from (d,3n)a

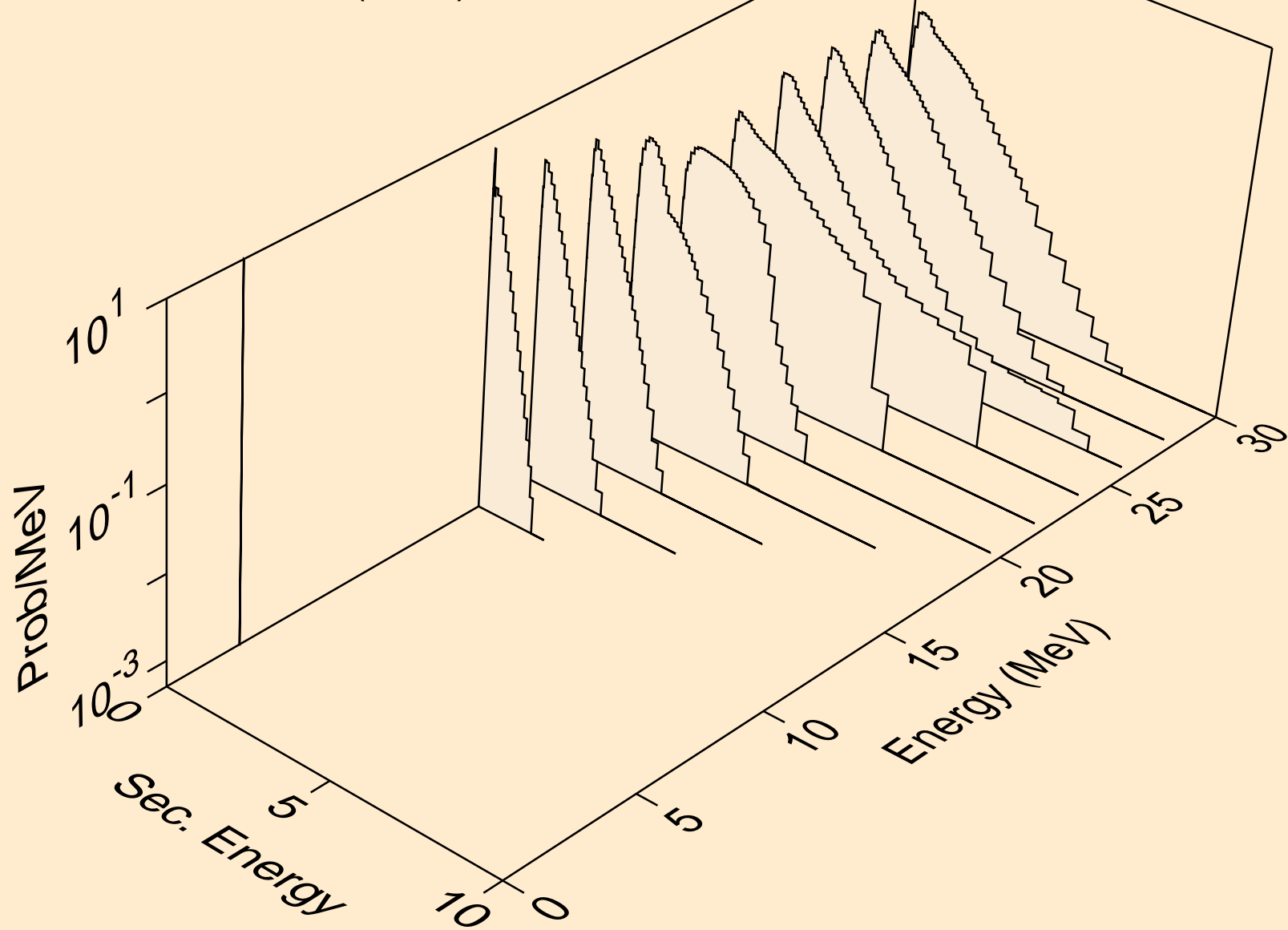

AC224 DEUTERON ACER TENDL-2024 LIBRARY; T=0.K  
neutrons from (d,n\*)p

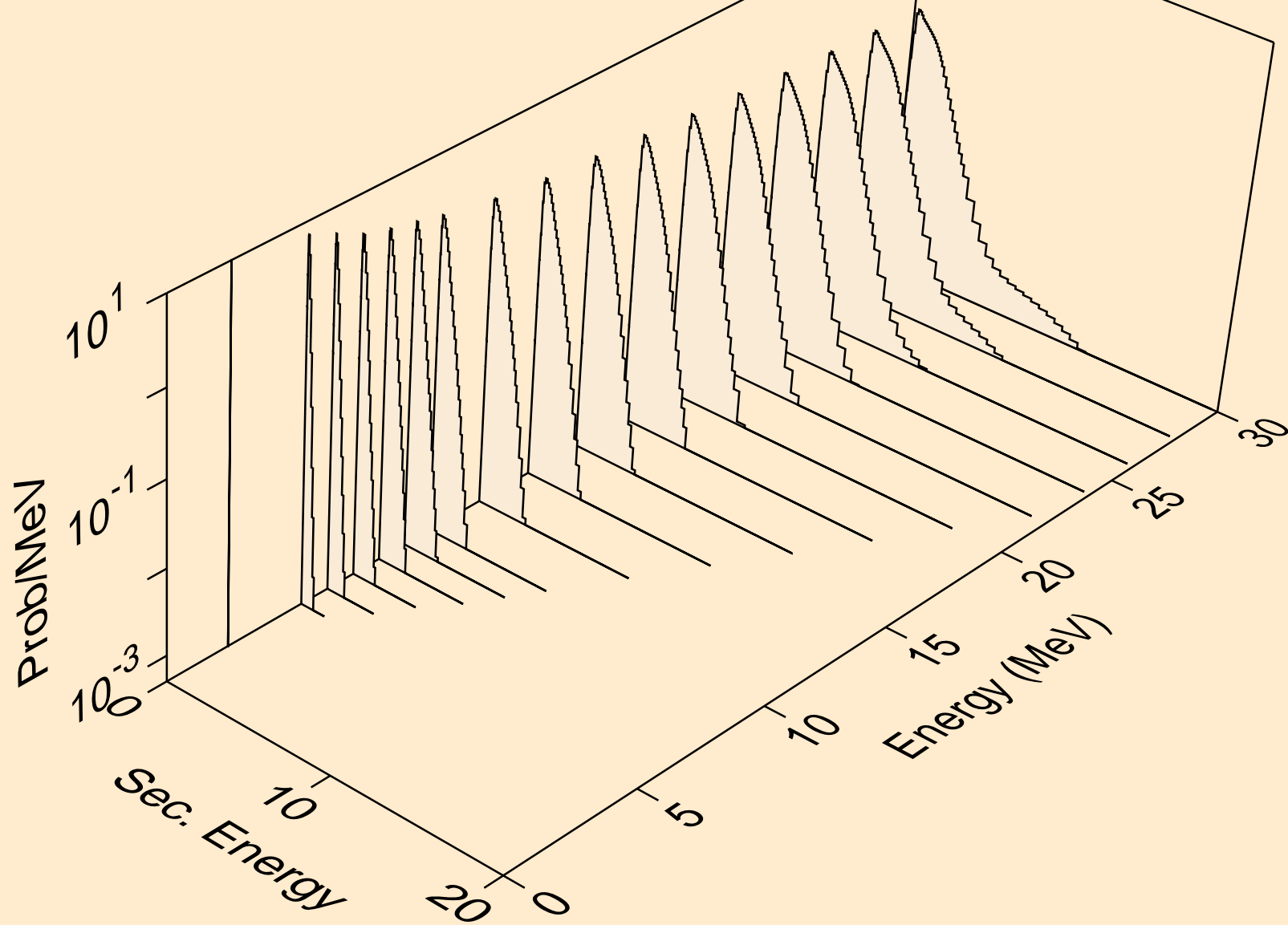

AC224 DEUTERON ACER TENDL-2024 LIBRARY; T=0.K  
neutrons from (d,n\*)2a

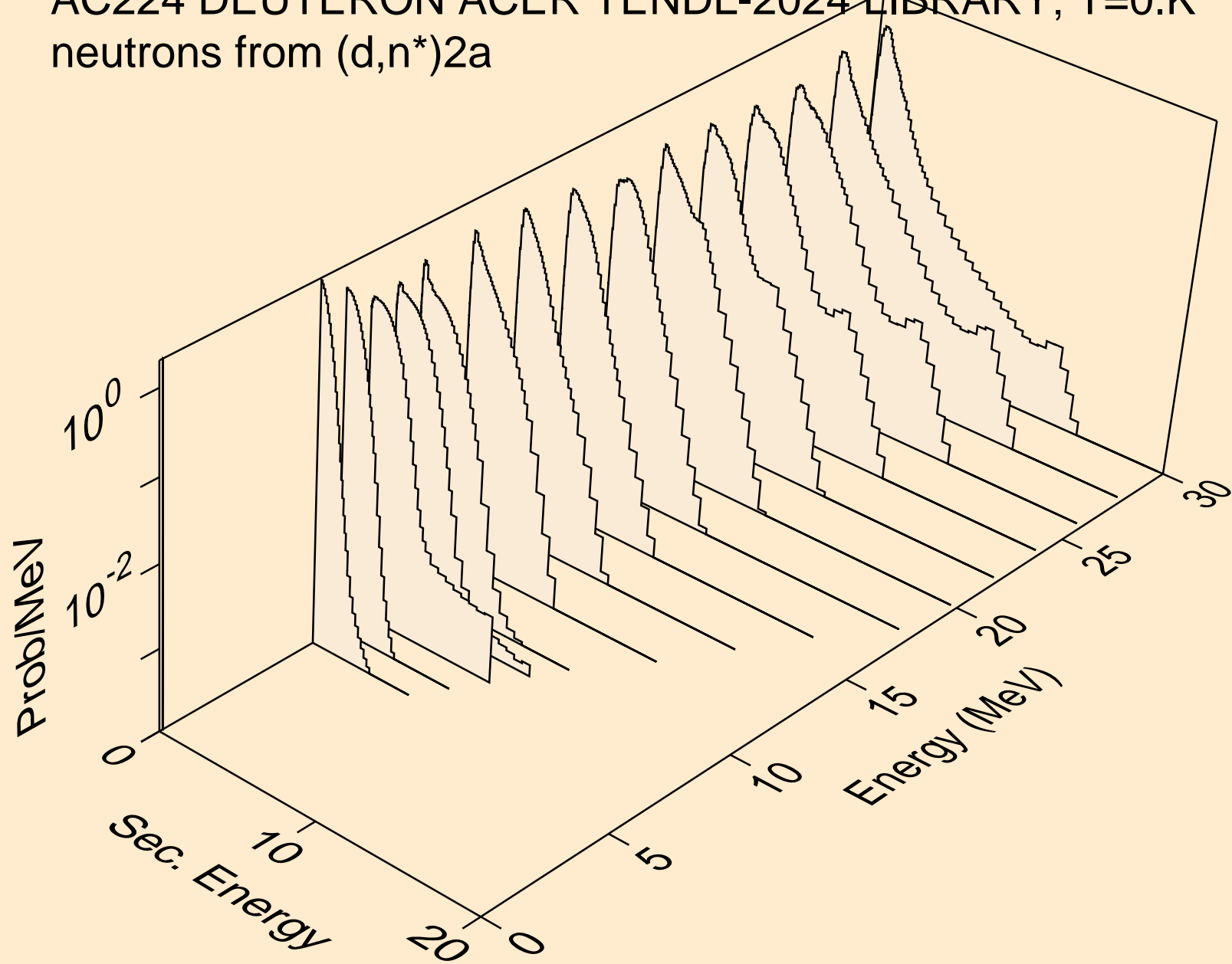

AC224 DEUTERON ACER TENDL-2024 LIBRARY; T=0.K  
neutrons from (d,2n)2a

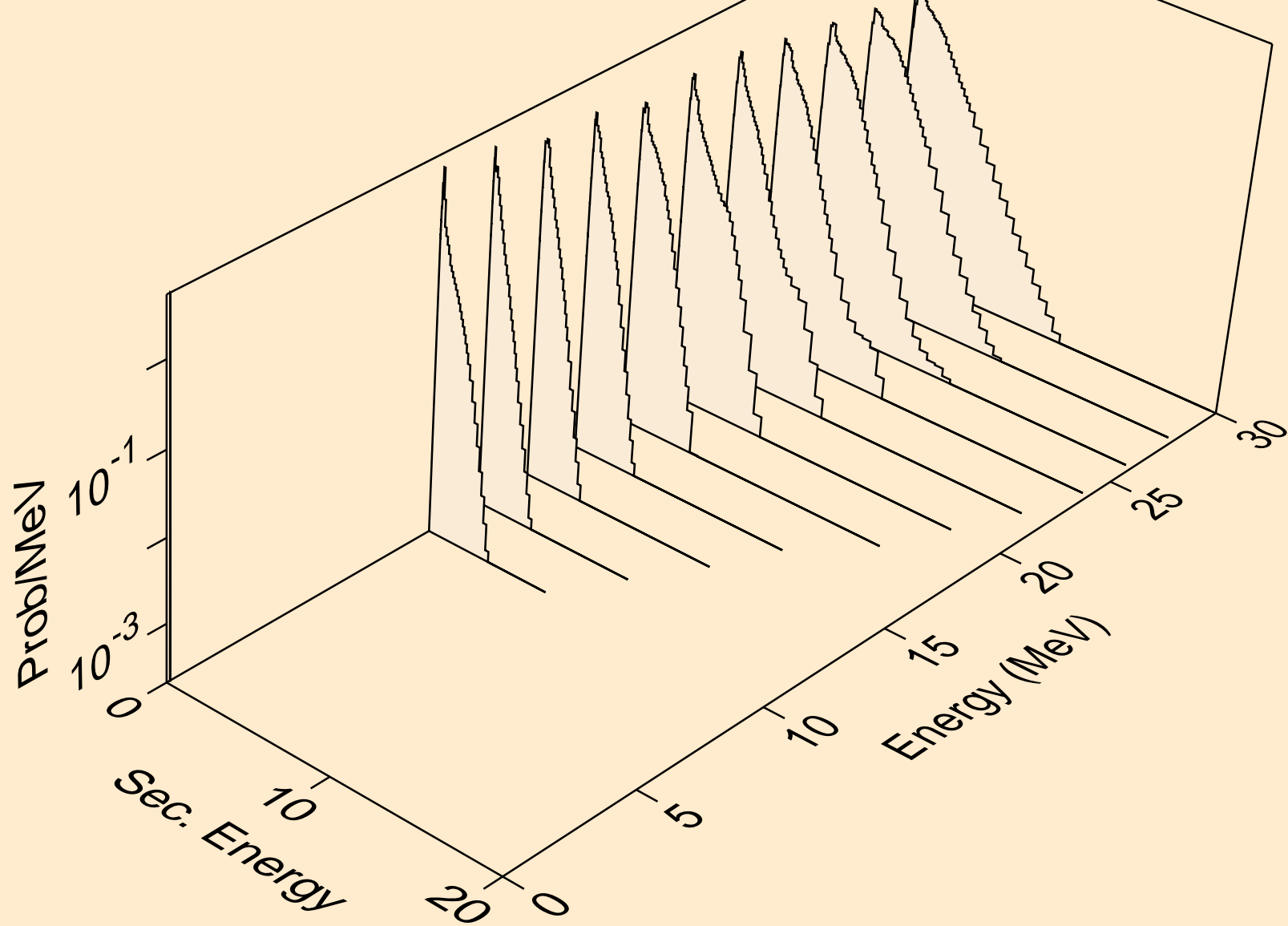

AC224 DEUTERON ACER TENDL-2024 LIBRARY; T=0.K  
neutrons from (d,n\*)d

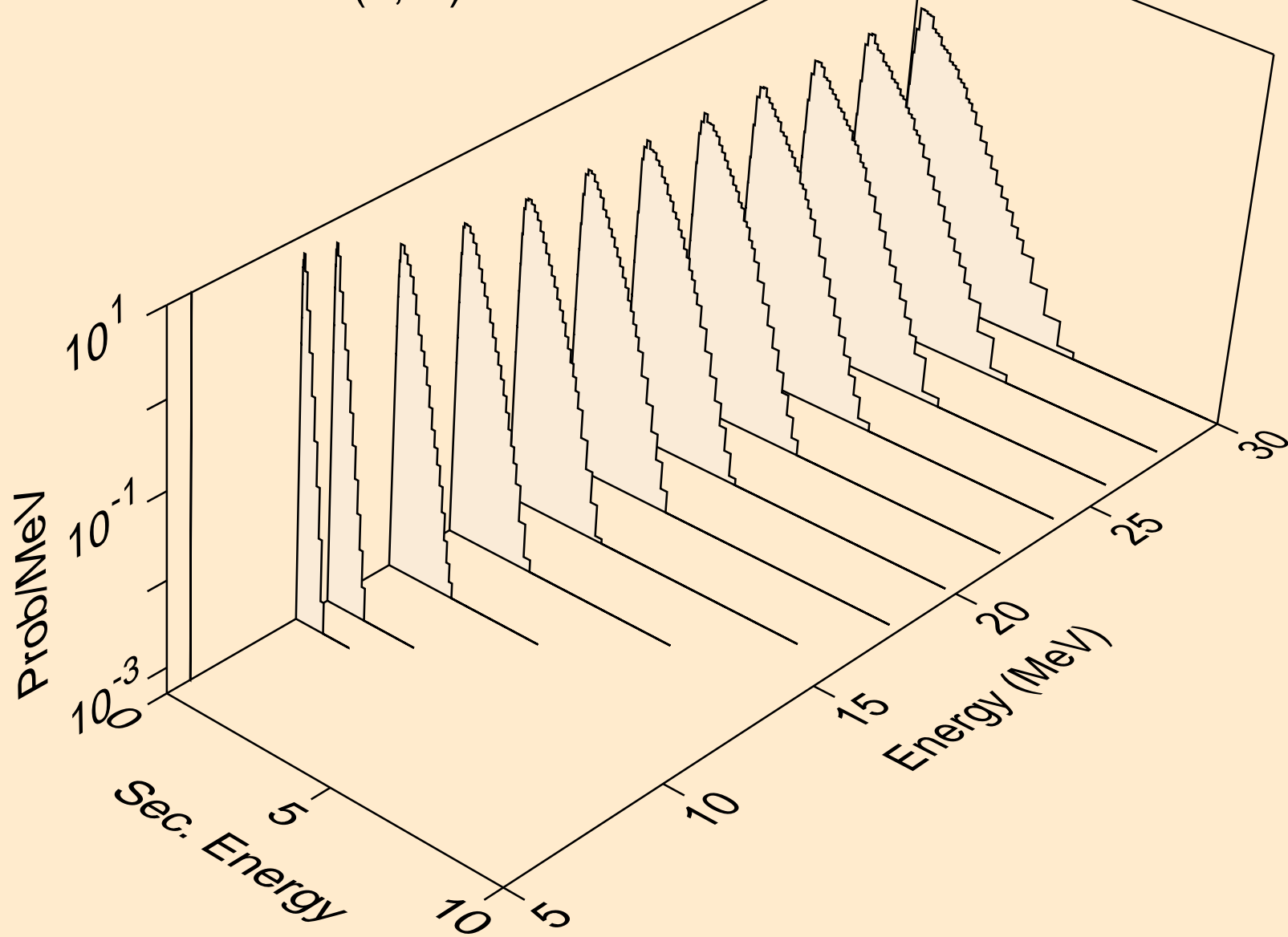

AC224 DEUTERON ACER TENDL-2024 LIBRARY; T=0.K  
neutrons from (d,n\*)t

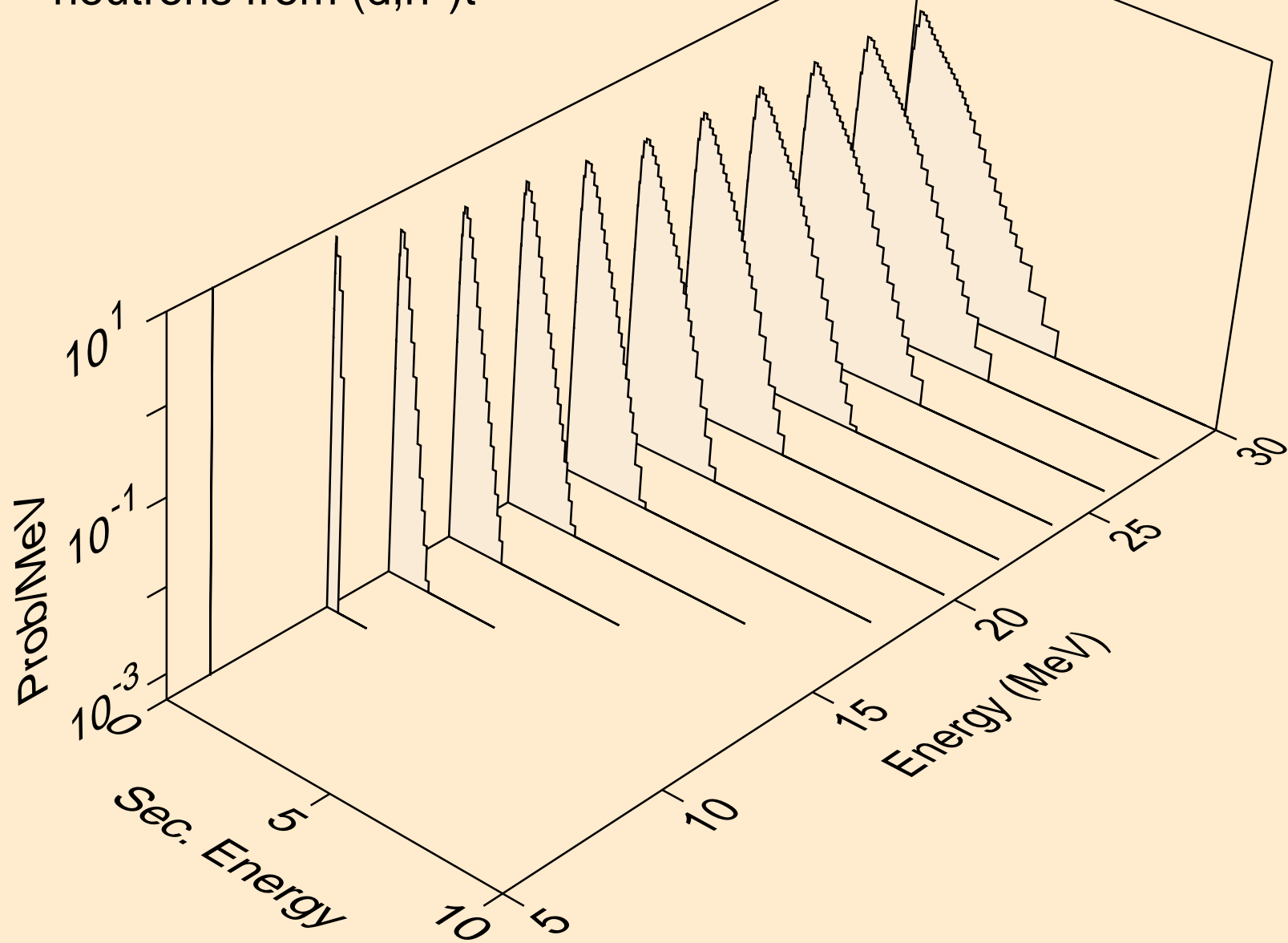

AC224 DEUTERON ACER TENDL-2024 LIBRARY; T=0.K  
neutrons from (d,n\*)he3

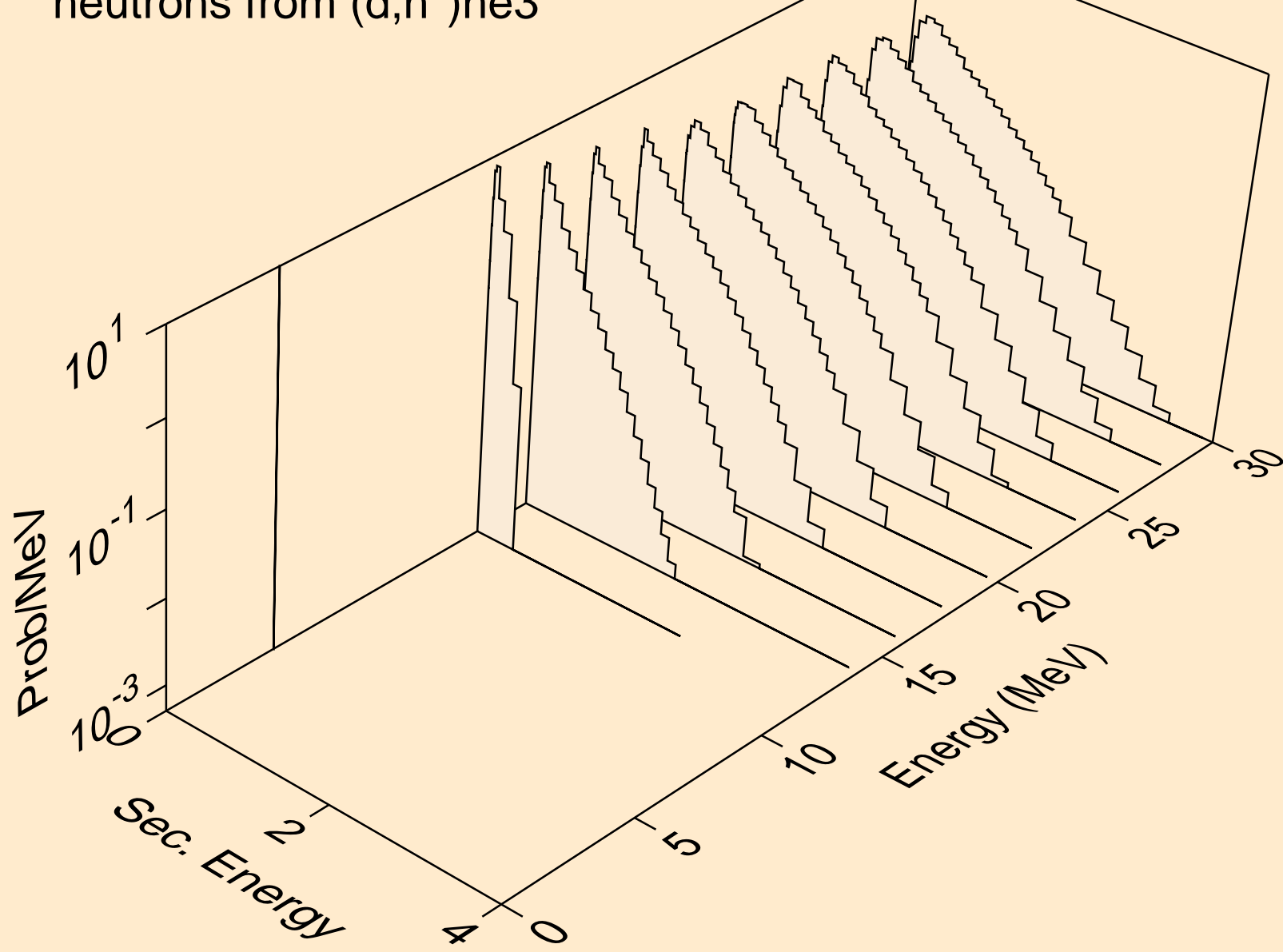

AC224 DEUTERON ACER TENDL-2024 LIBRARY; T=0.K  
neutrons from (d,4n)

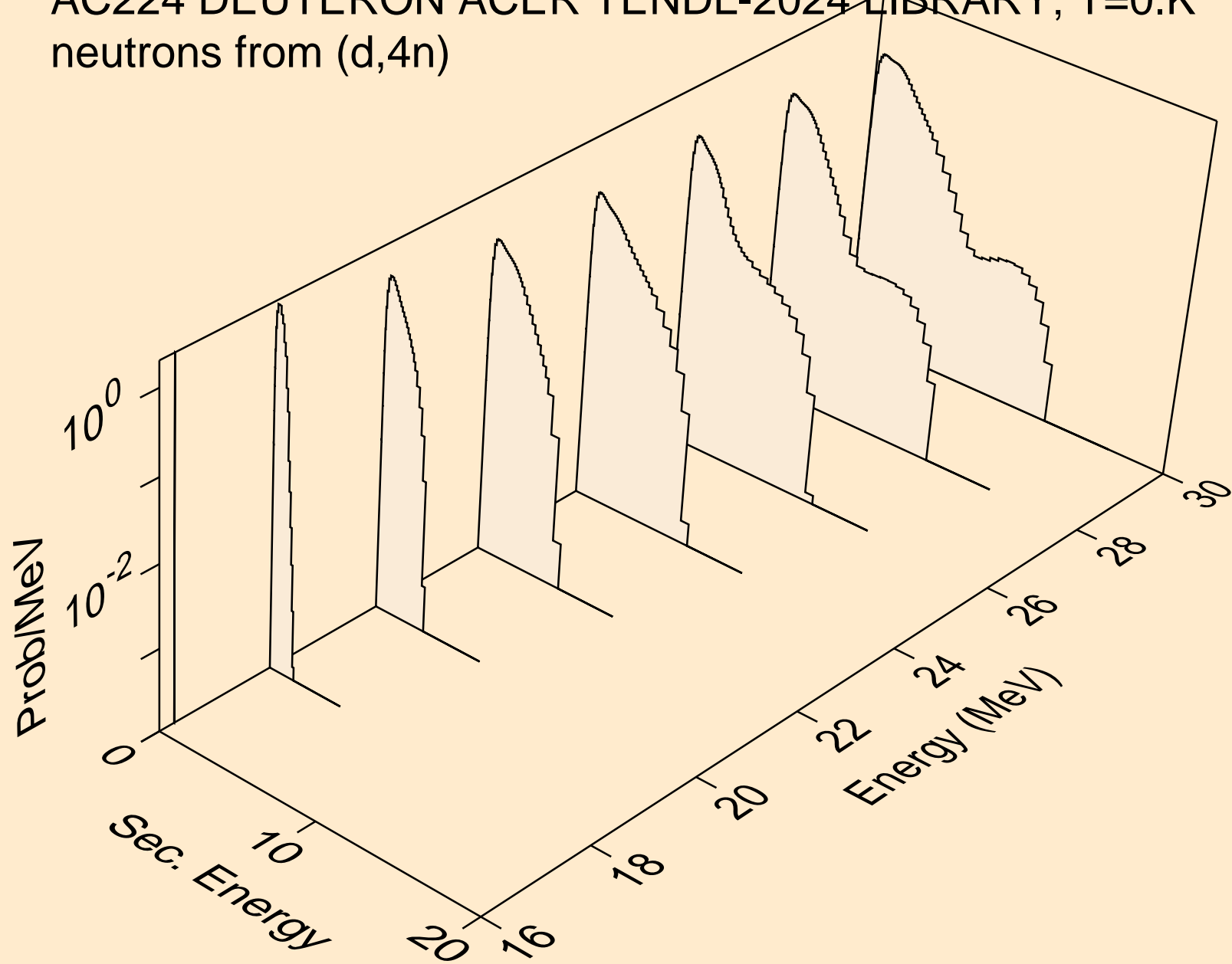

AC224 DEUTERON ACER TENDL-2024 LIBRARY; T=0.K  
neutrons from (d,2np)

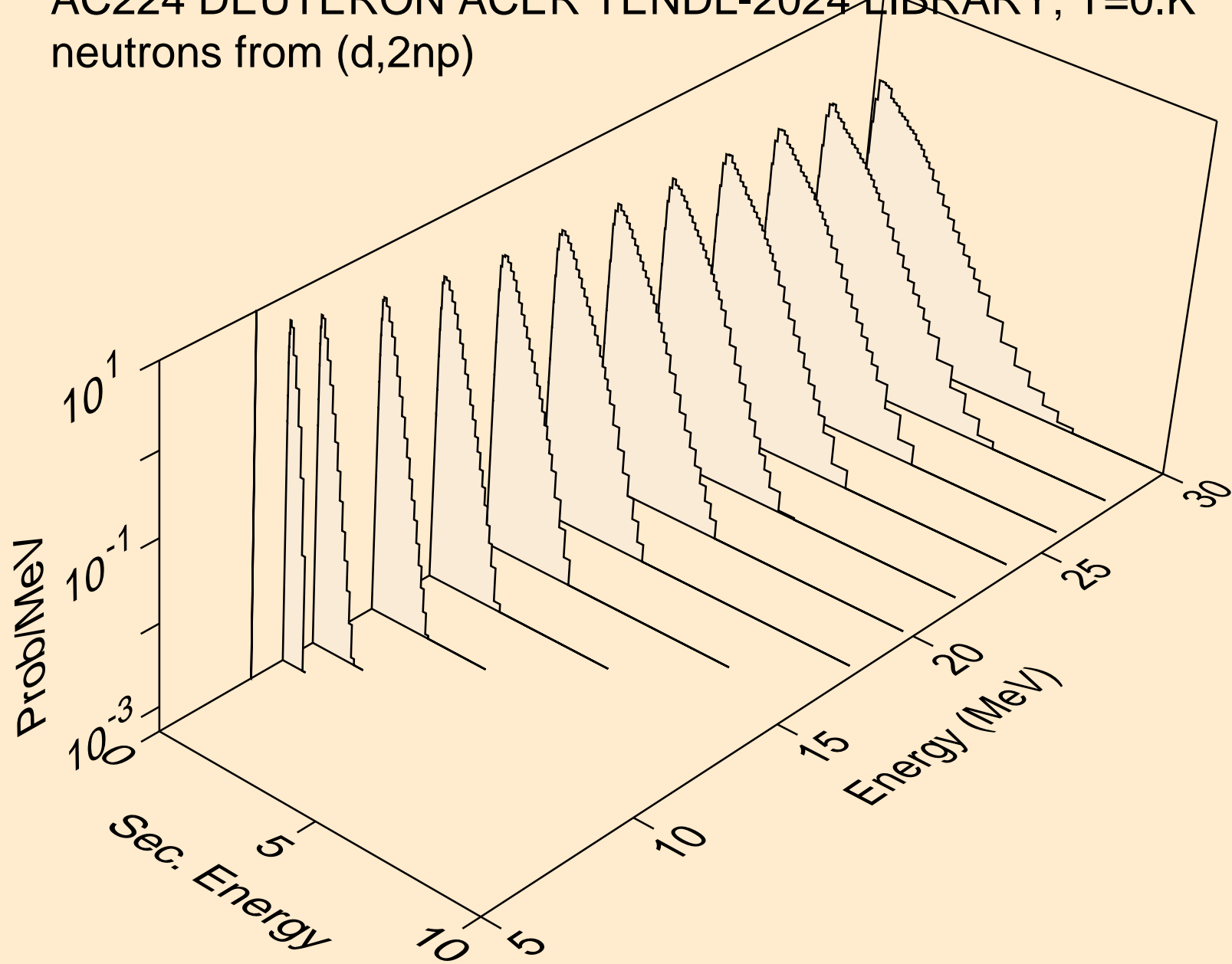

AC224 DEUTERON ACER TENDL-2024 LIBRARY; T=0.K  
neutrons from (d,3np)

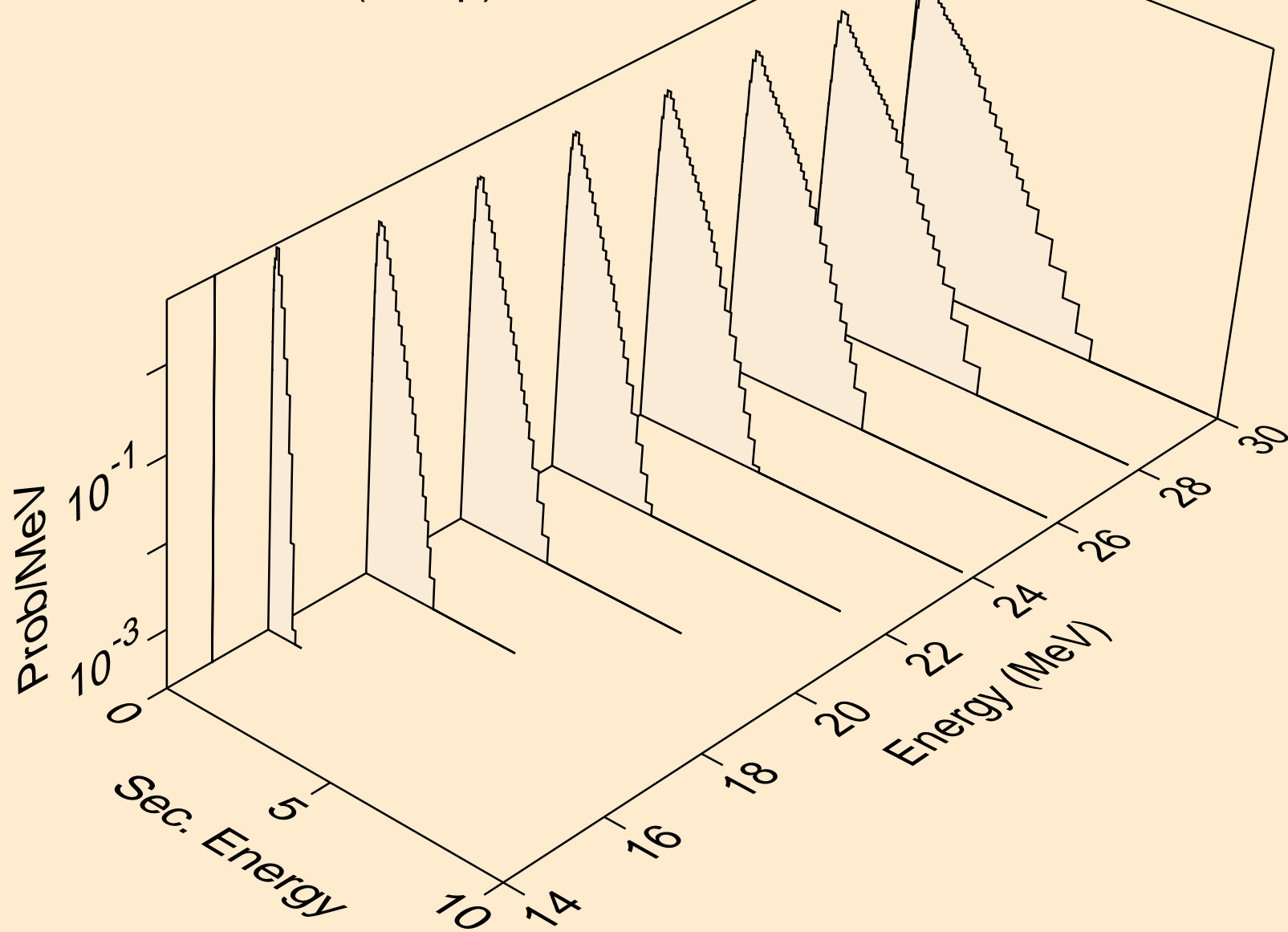

AC224 DEUTERON ACER TENDL-2024 LIBRARY; T=0.K  
neutrons from (d,n2p)

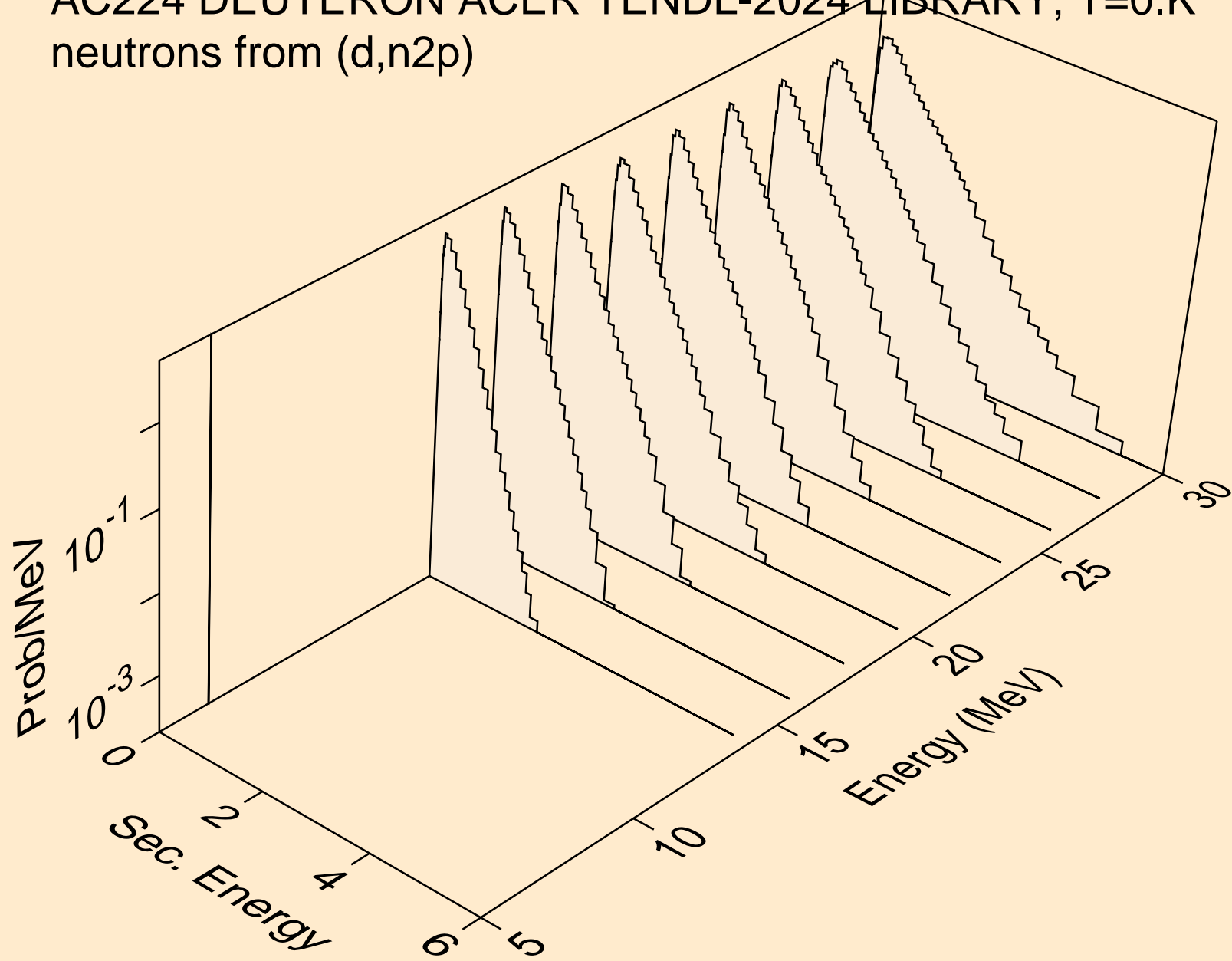

AC224 DEUTERON ACER TENDL-2024 LIBRARY; T=0.K  
neutrons from (d,npa)

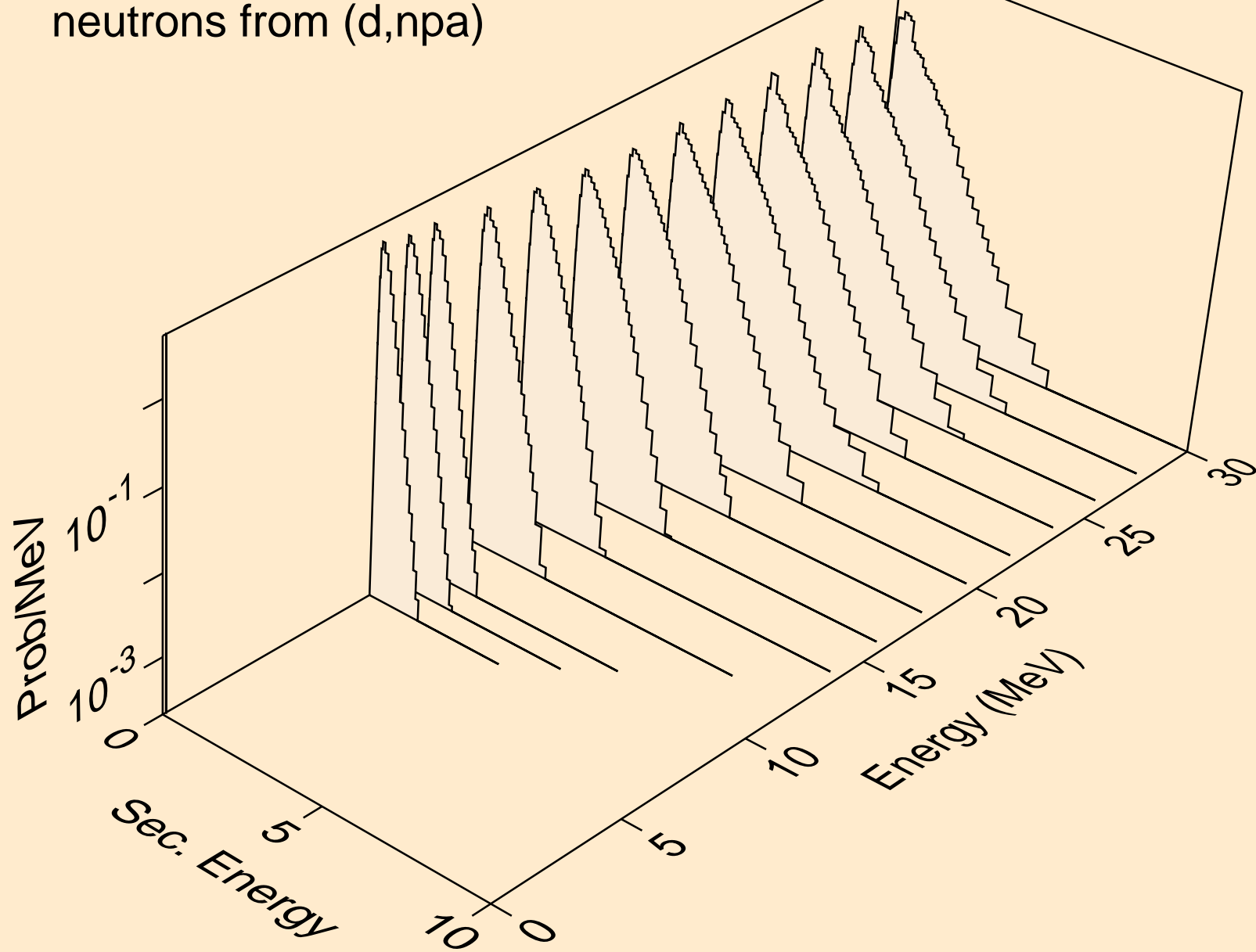

AC224 DEUTERON ACER TENDL-2024 LIBRARY; T=0.K  
protons from (d,x)

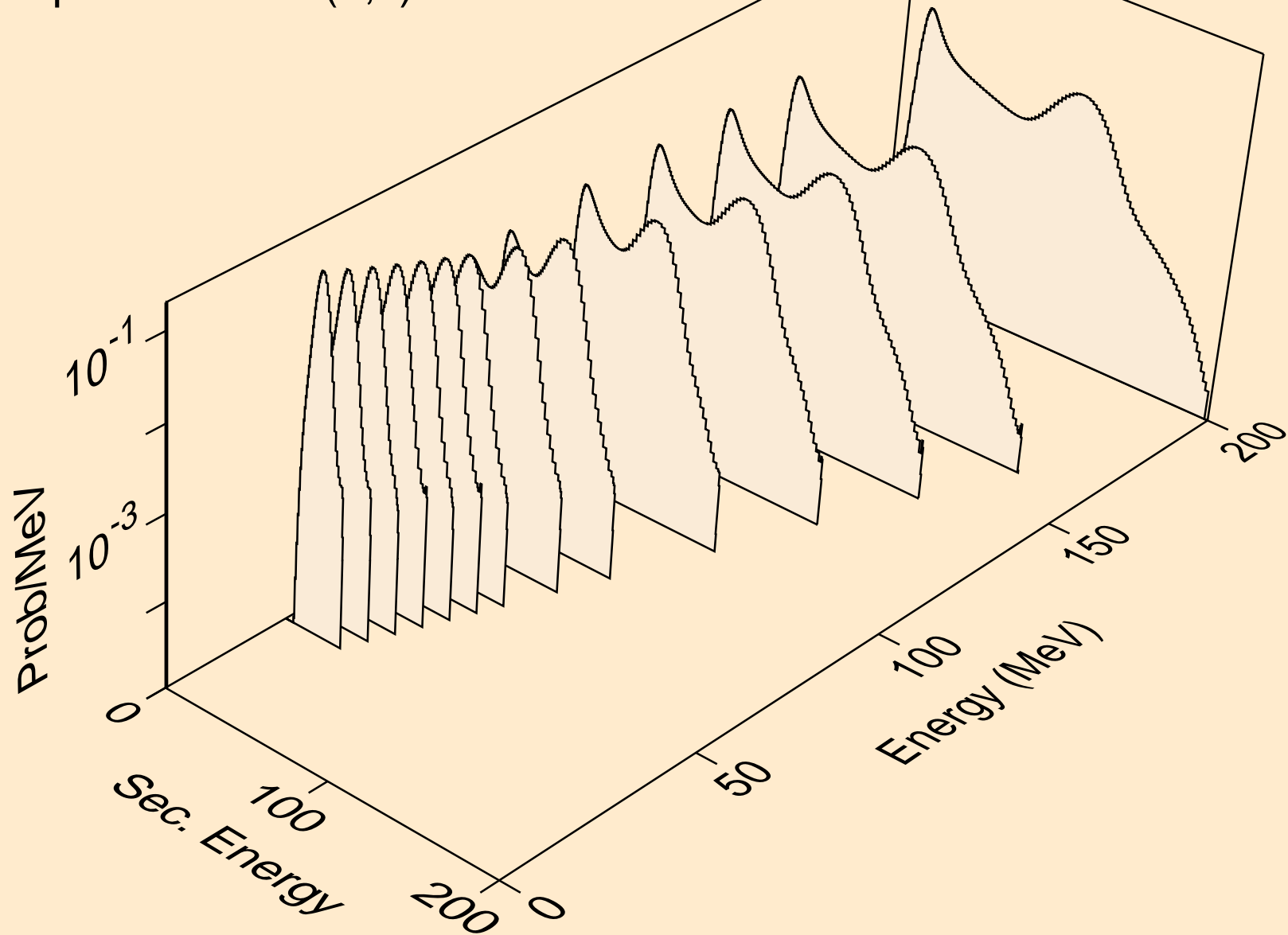

AC224 DEUTERON ACER TENDL-2024 LIBRARY; T=0.K  
protons from (d,n\*)p

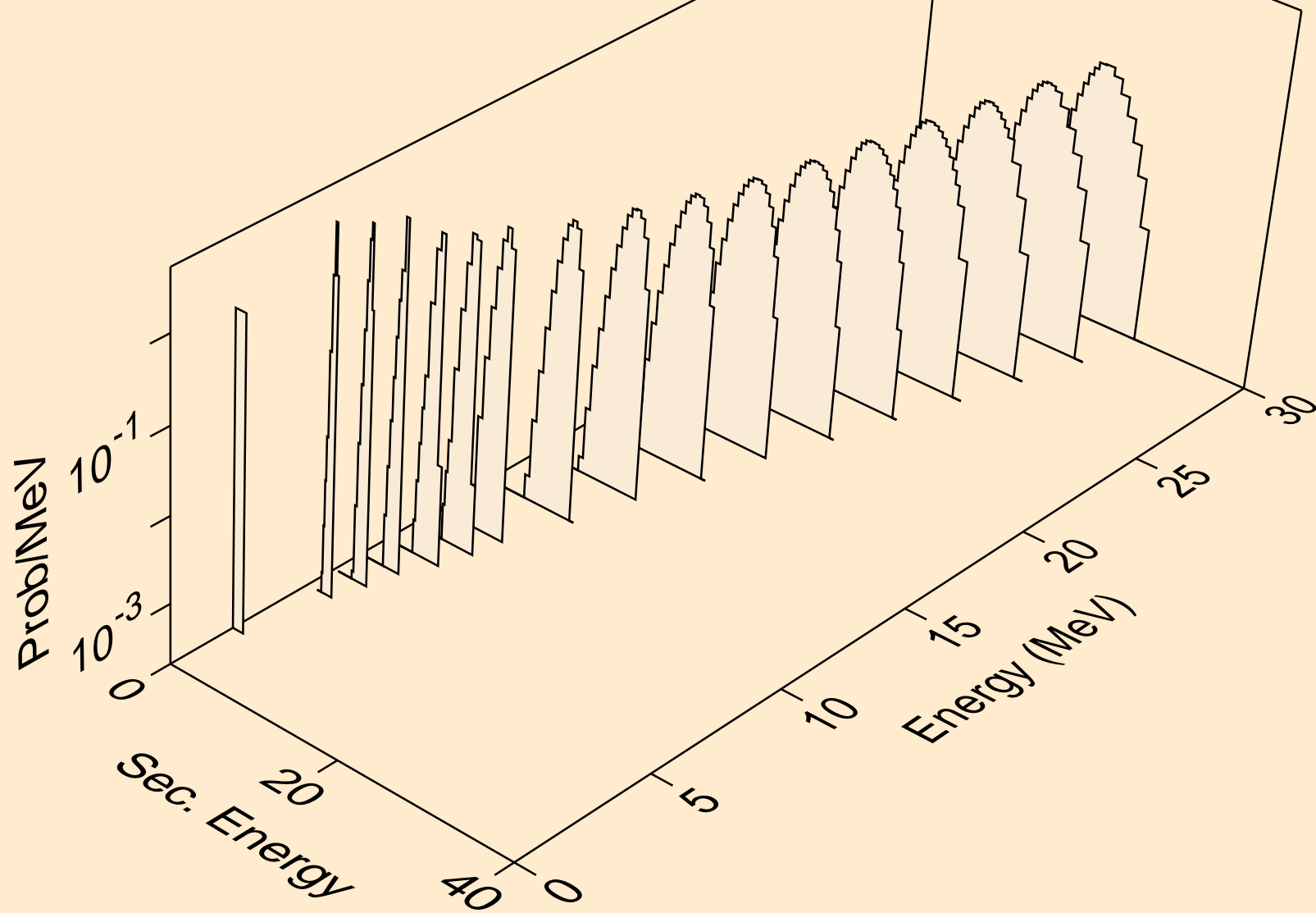

AC224 DEUTERON ACER TENDL-2024 LIBRARY; T=0.K  
protons from (d,2np)

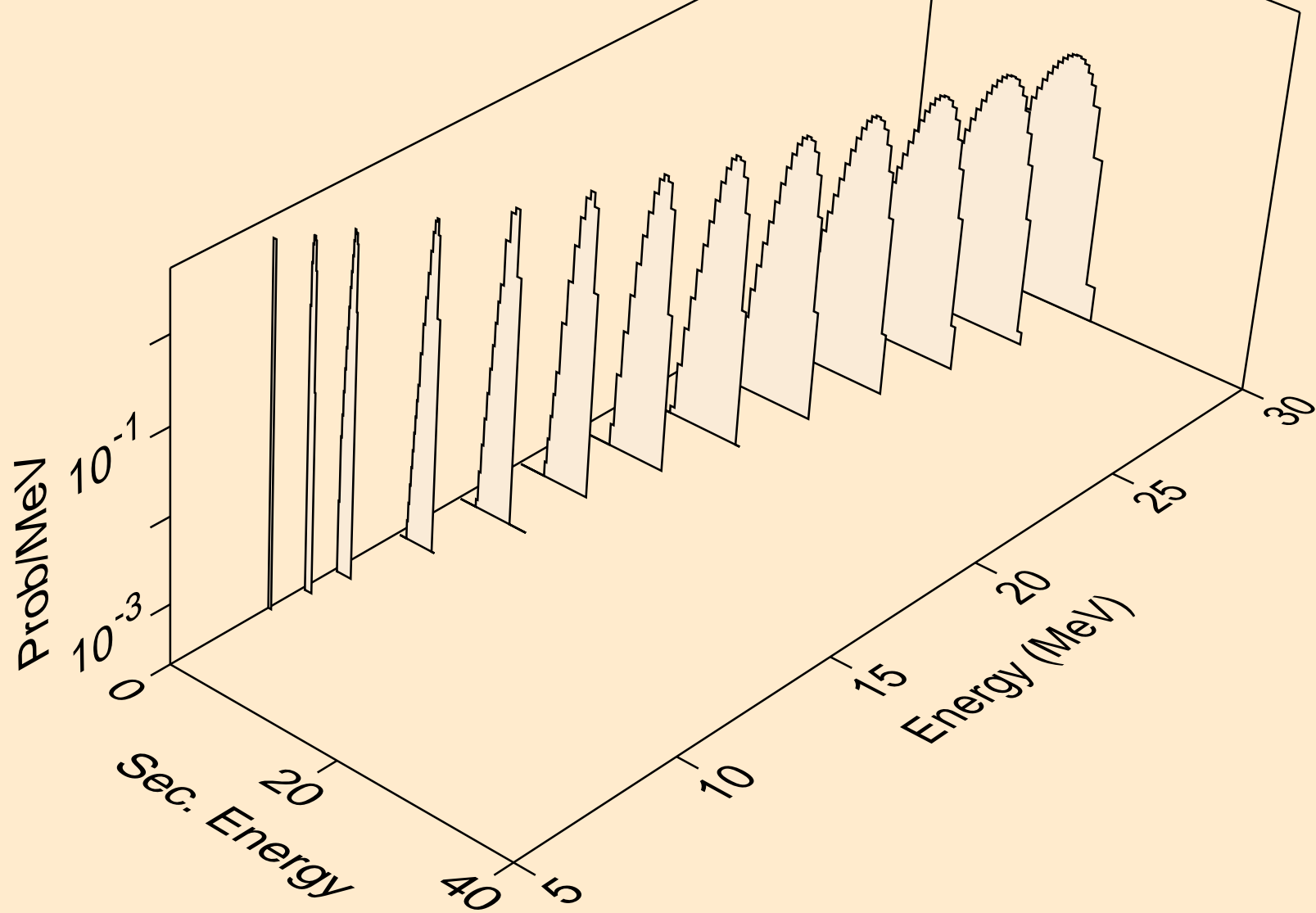

AC224 DEUTERON ACER TENDL-2024 LIBRARY; T=0.K  
protons from (d,3np)

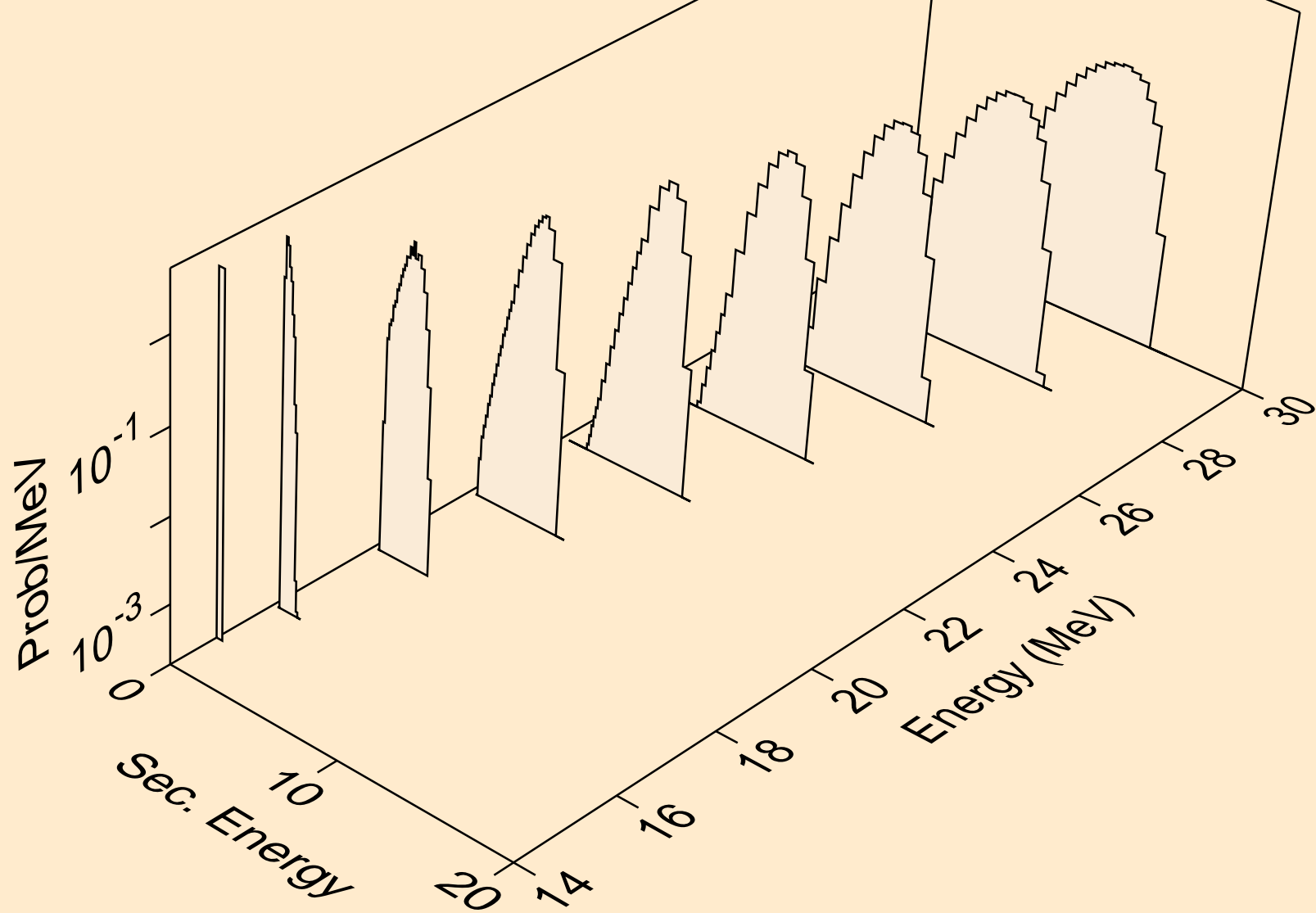

AC224 DEUTERON ACER TENDL-2024 LIBRARY; T=0.K  
protons from (d,n2p)

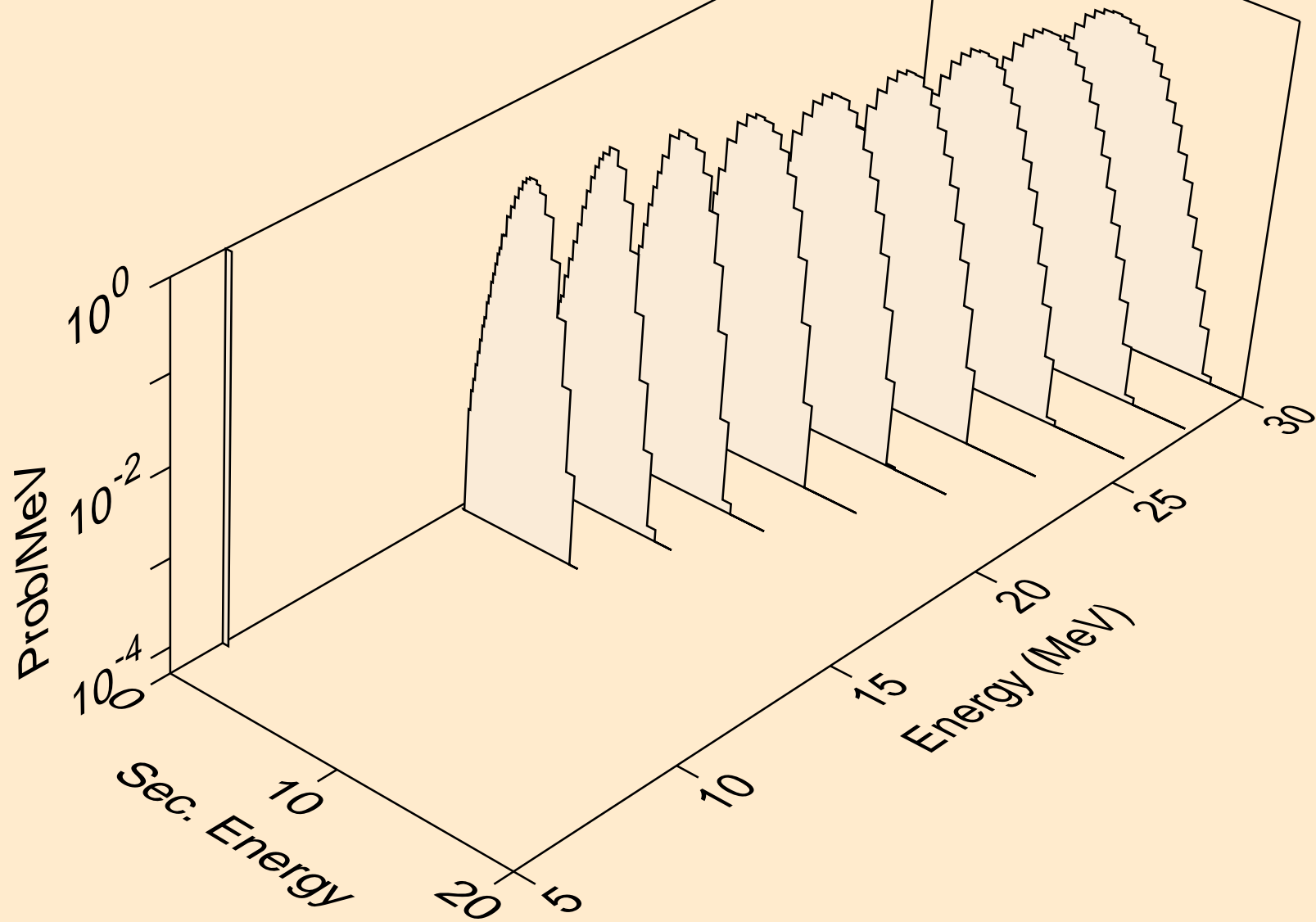

AC224 DEUTERON ACER TENDL-2024 LIBRARY; T=0.K  
protons from (d,npa)

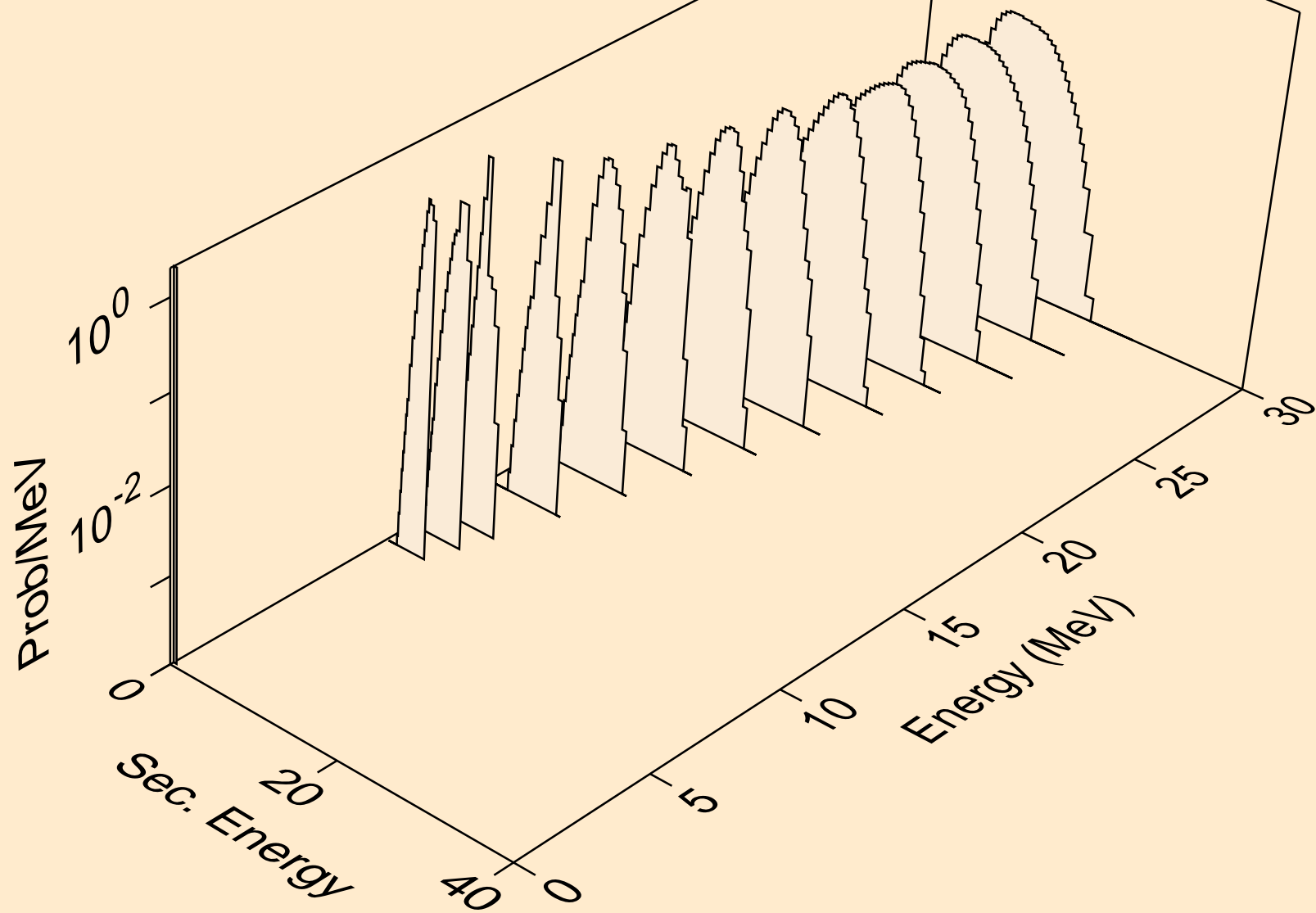

AC224 DEUTERON ACER TENDL-2024 LIBRARY; T=0.K  
protons from (d,p)

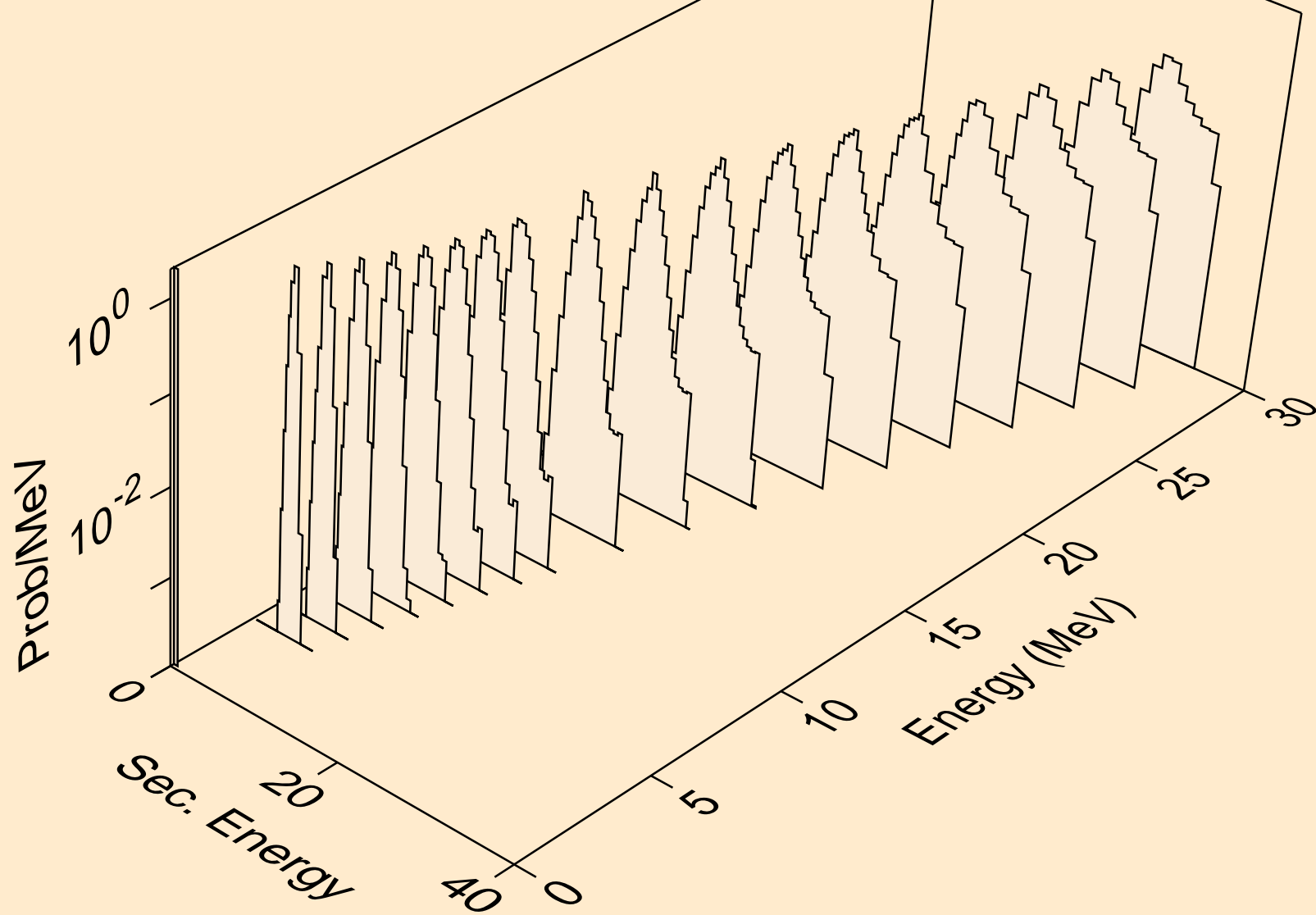

AC224 DEUTERON ACER TENDL-2024 LIBRARY; T=0.K  
protons from (d,2p)

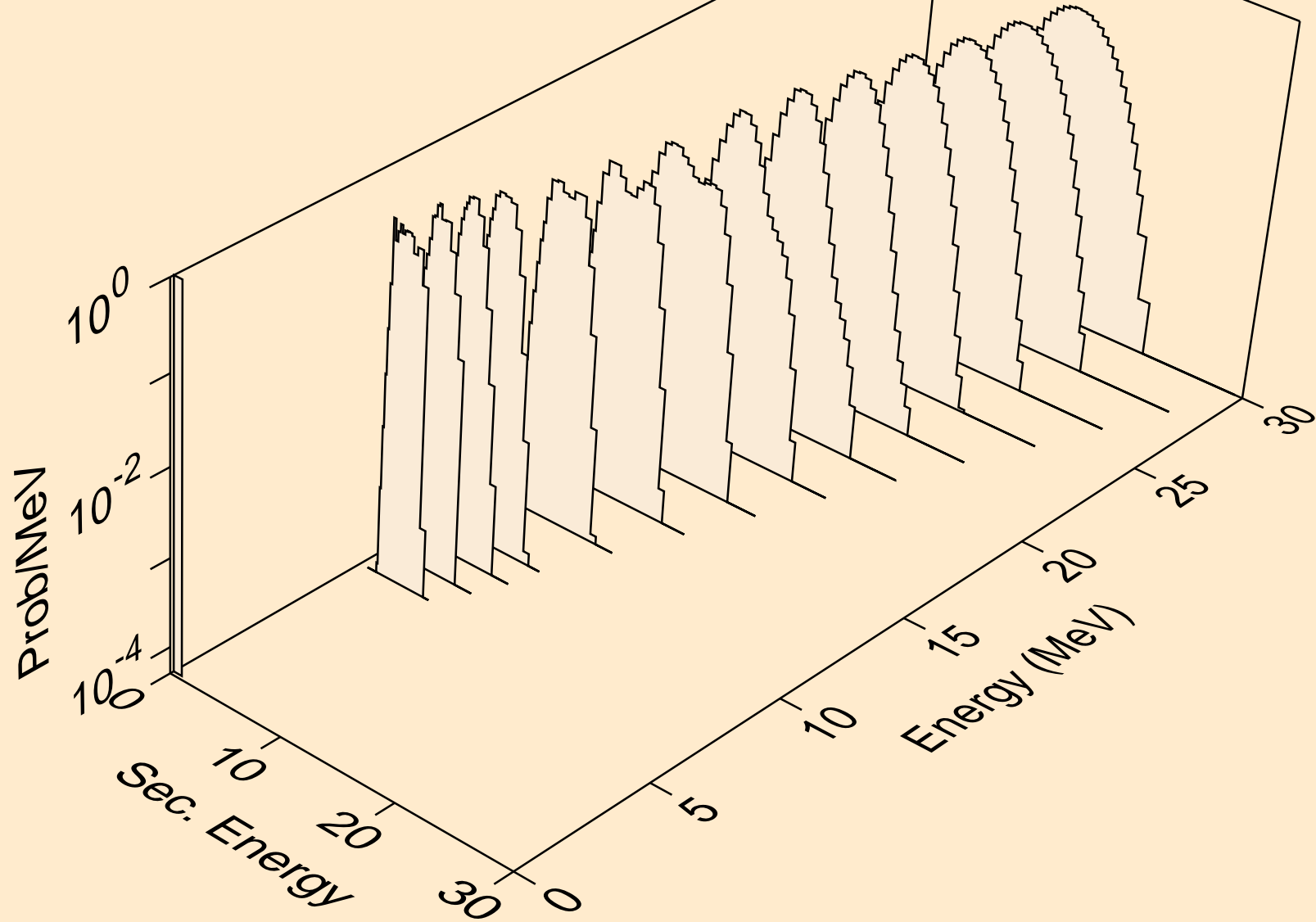

AC224 DEUTERON ACER TENDL-2024 LIBRARY; T=0.K  
protons from (d,pa)

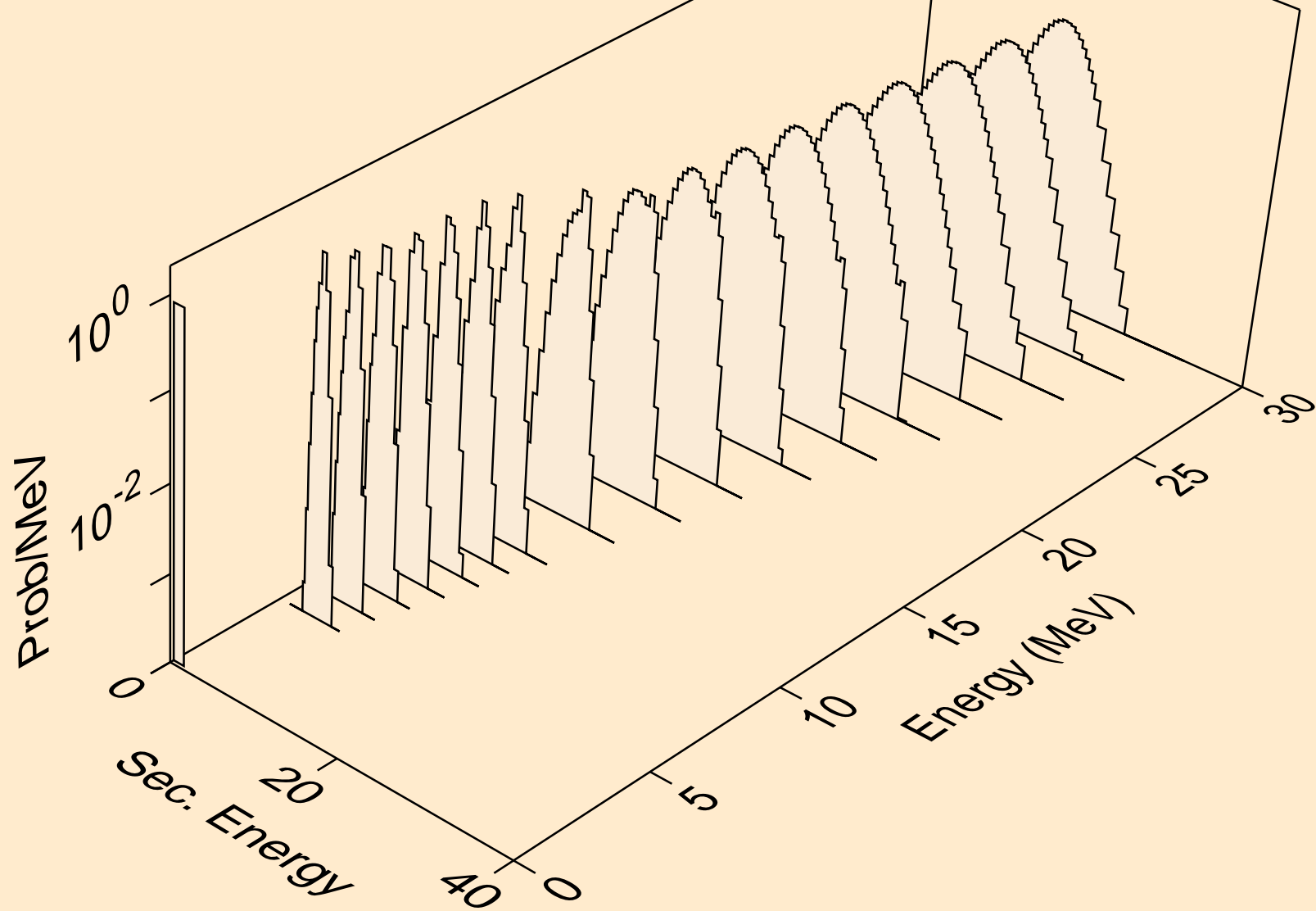

AC224 DEUTERON ACER TENDL-2024 LIBRARY; T=0.K  
protons from (d,pd)

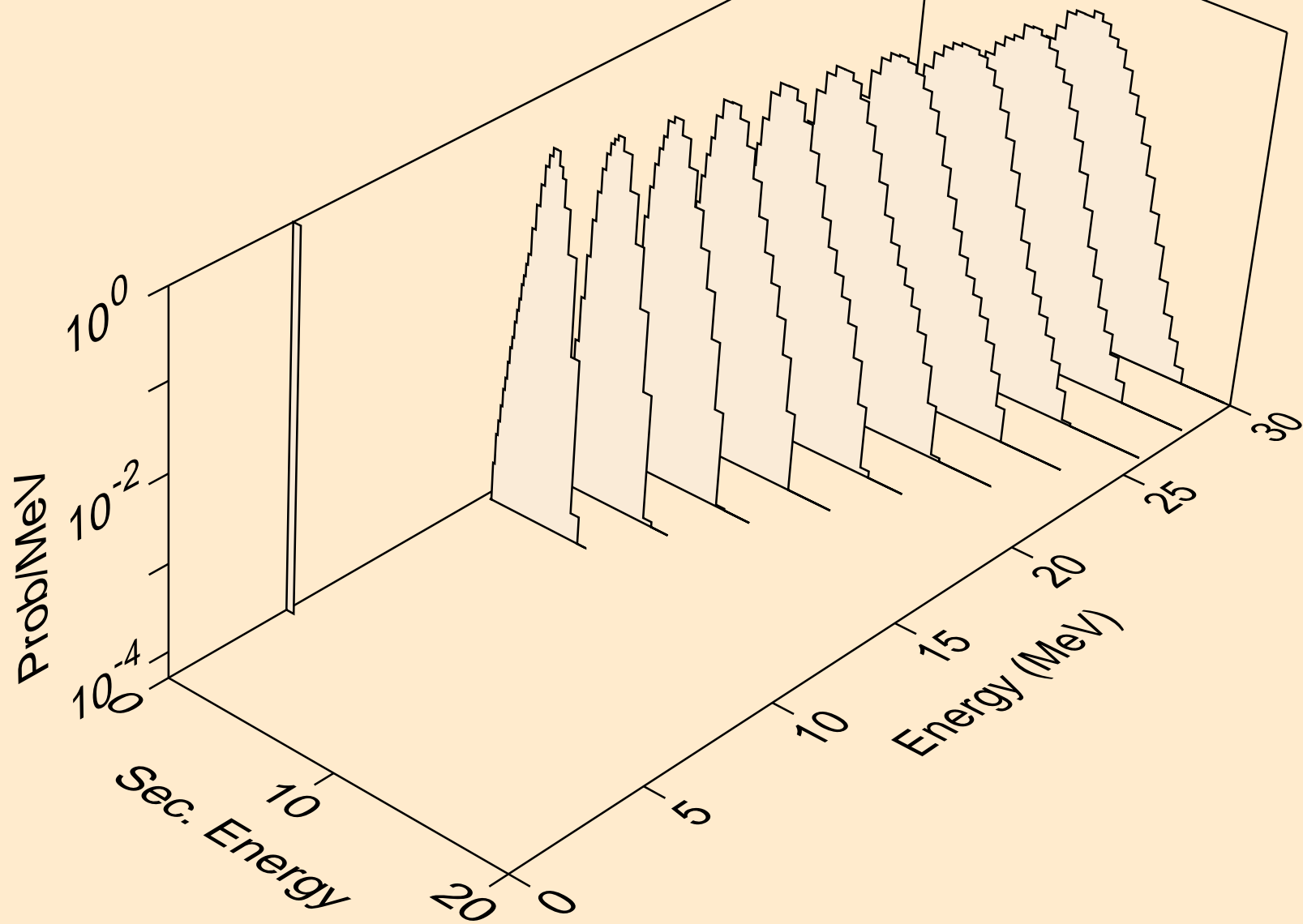

AC224 DEUTERON ACER TENDL-2024 LIBRARY; T=0.K  
protons from (d,pt)

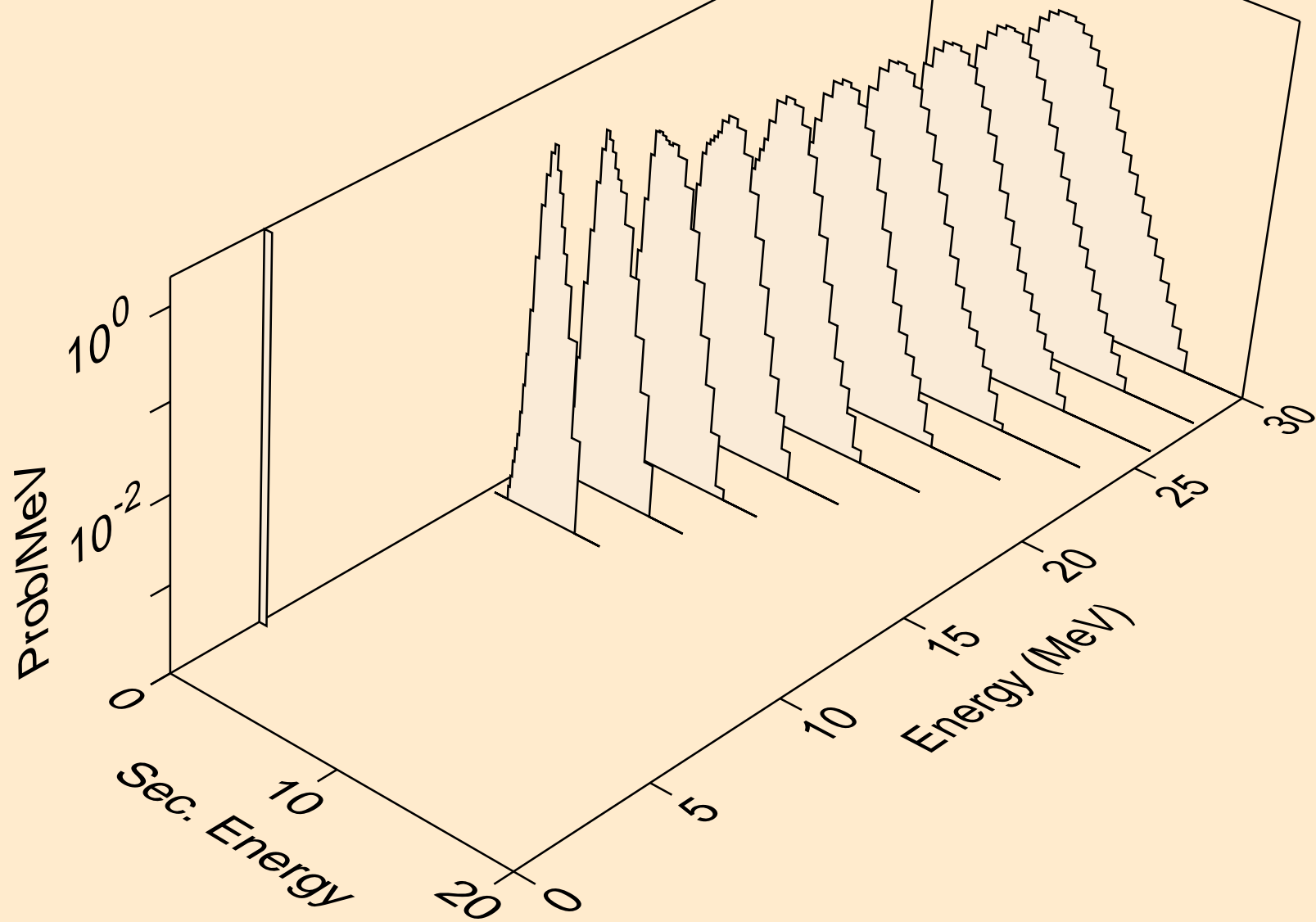

AC224 DEUTERON ACER TENDL-2024 LIBRARY; T=0.K  
tritons from (d,x)

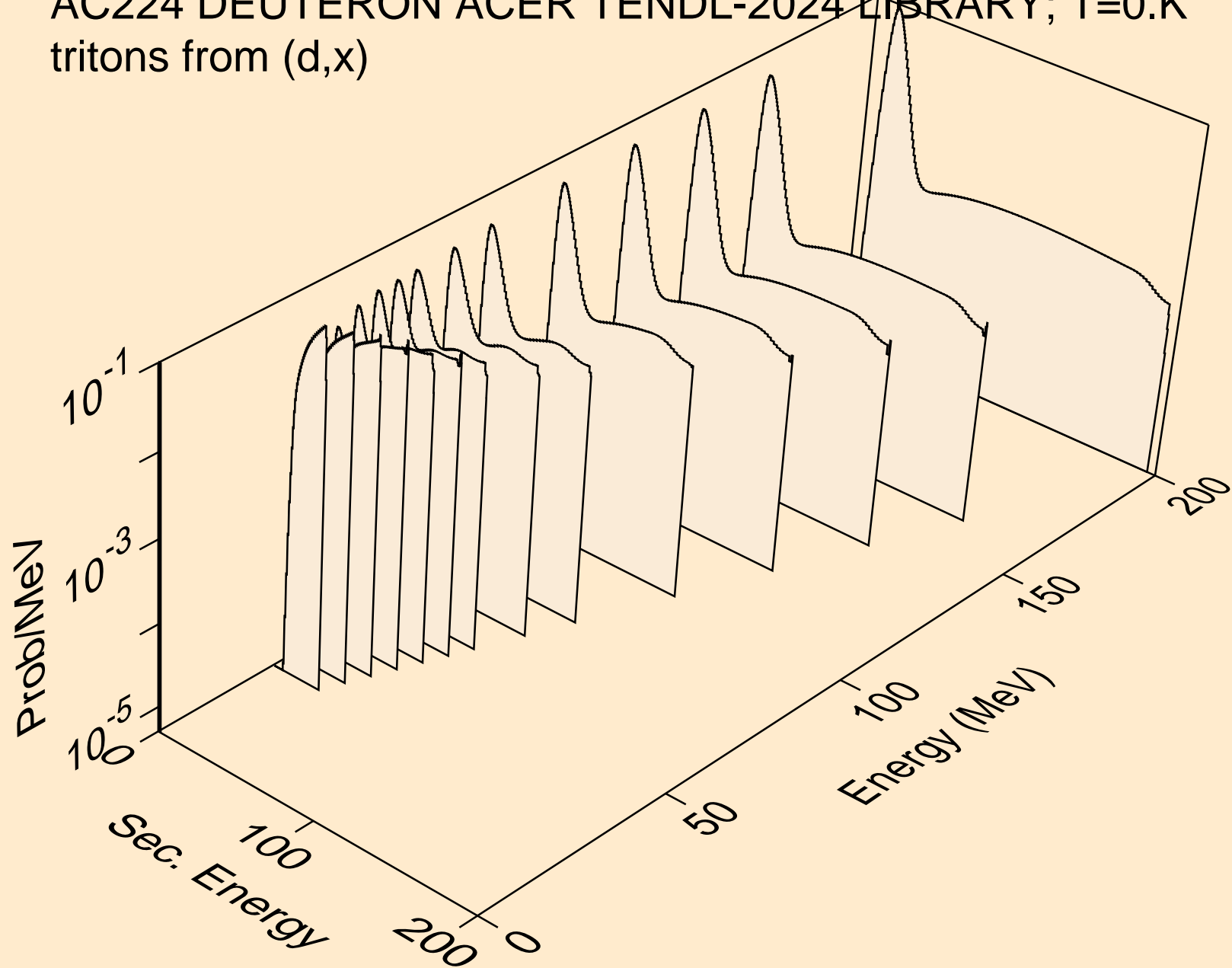

AC224 DEUTERON ACER TENDL-2024 LIBRARY; T=0.K  
tritons from (d,n\*)t

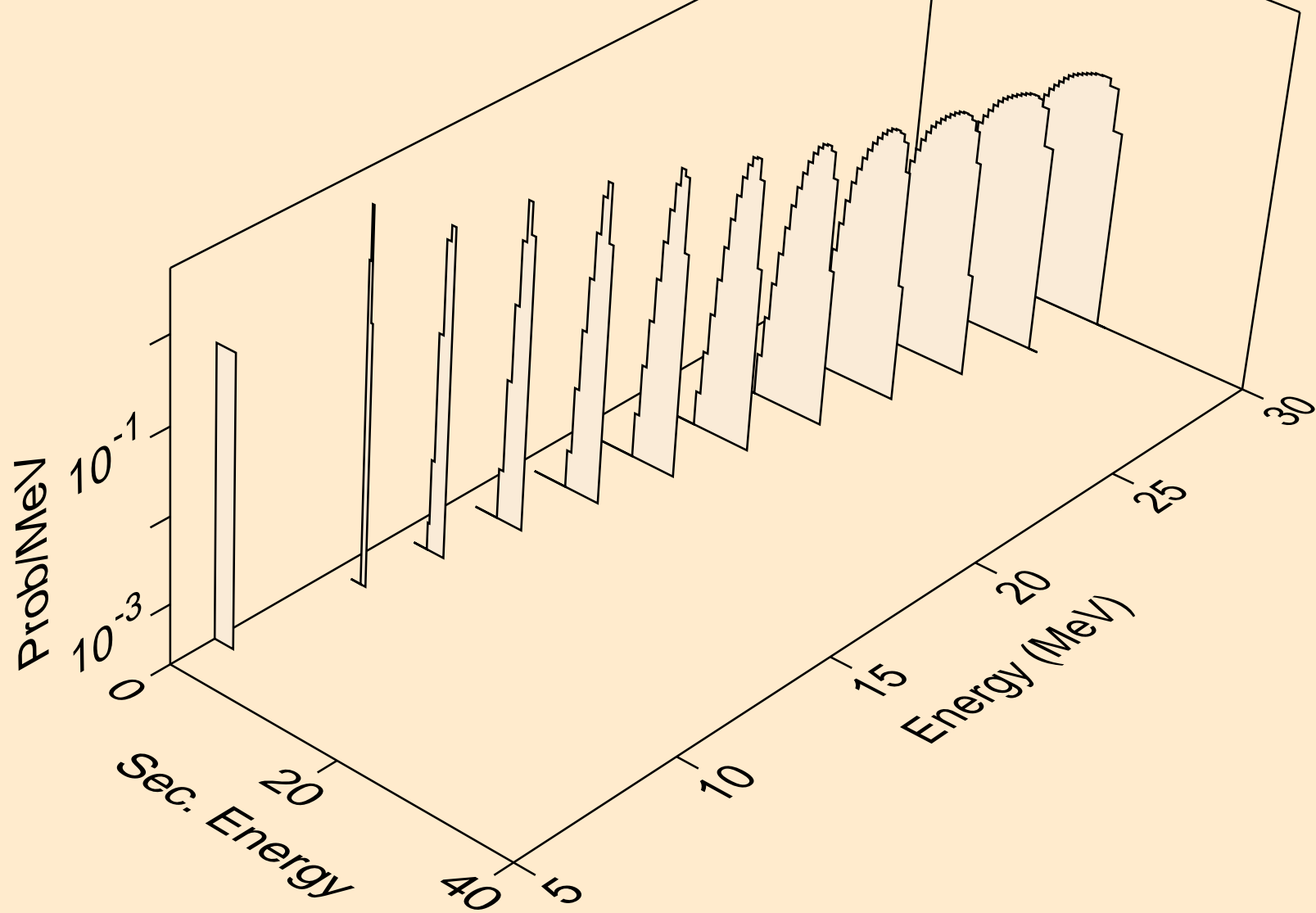

AC224 DEUTERON ACER TENDL-2024 LIBRARY; T=0.K  
tritons from (d,t)

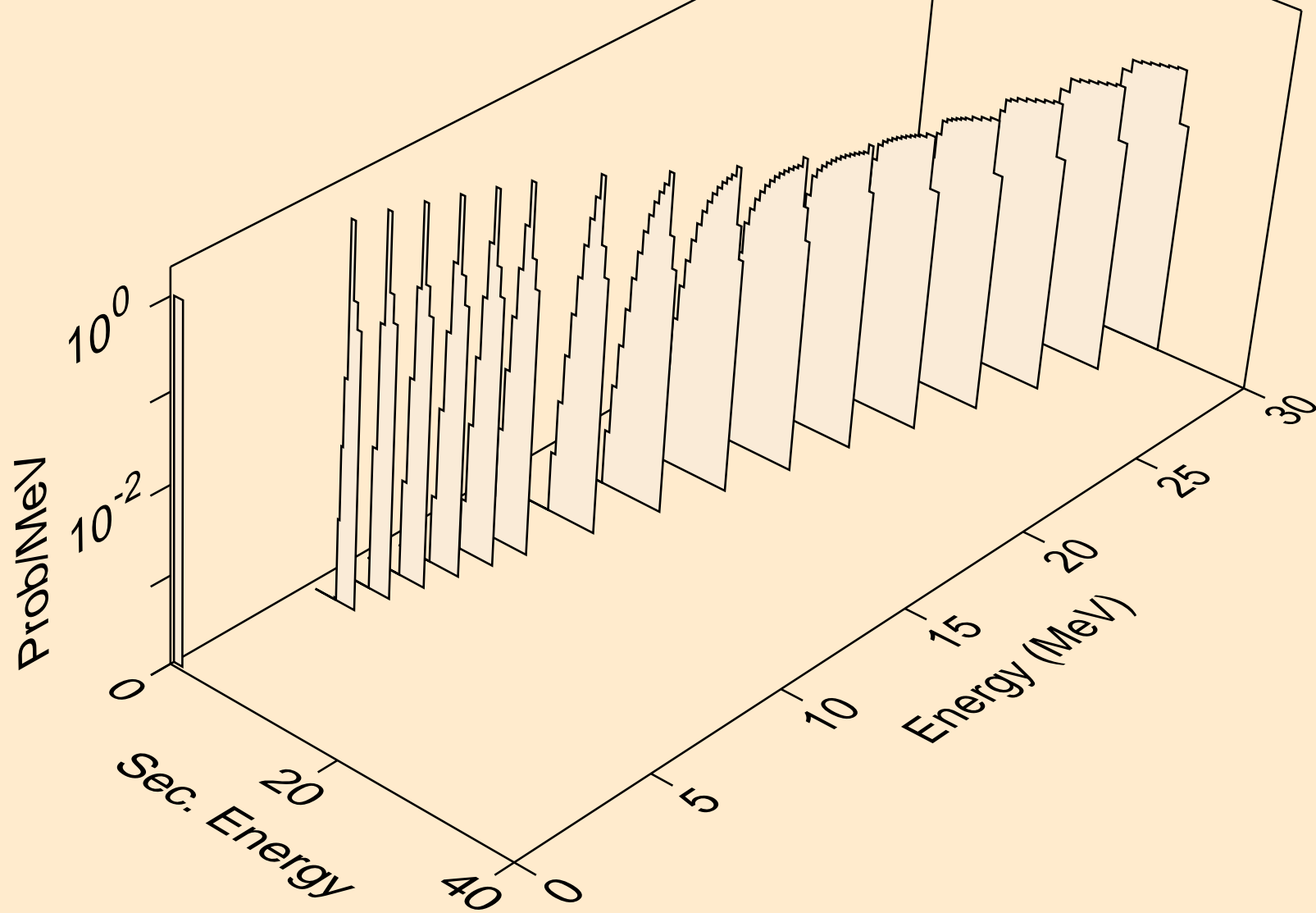

AC224 DEUTERON ACER TENDL-2024 LIBRARY; T=0.K  
tritons from (d,pt)

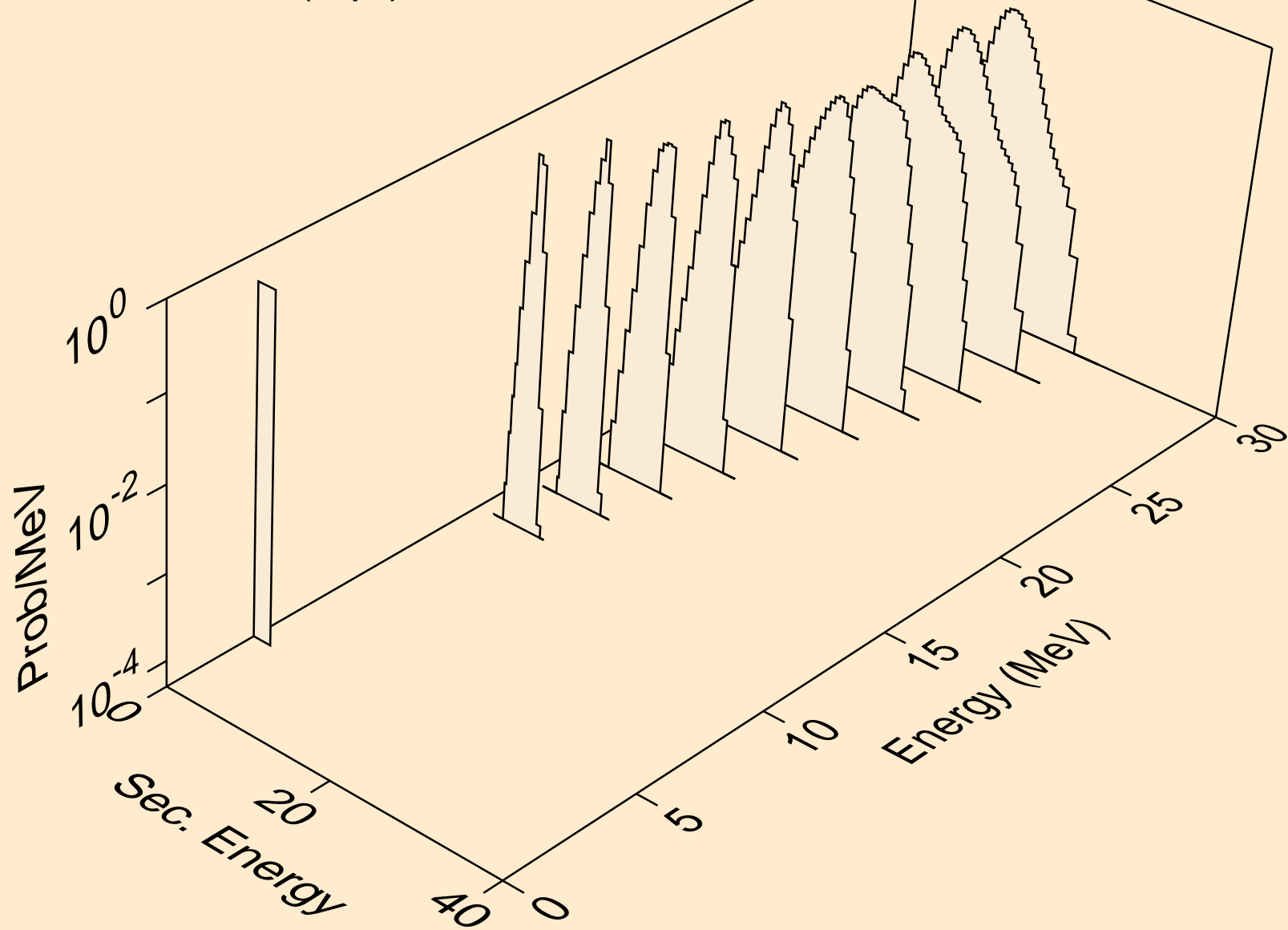

AC224 DEUTERON ACER TENDL-2024 LIBRARY; T=0.K  
he3s from (d,x)

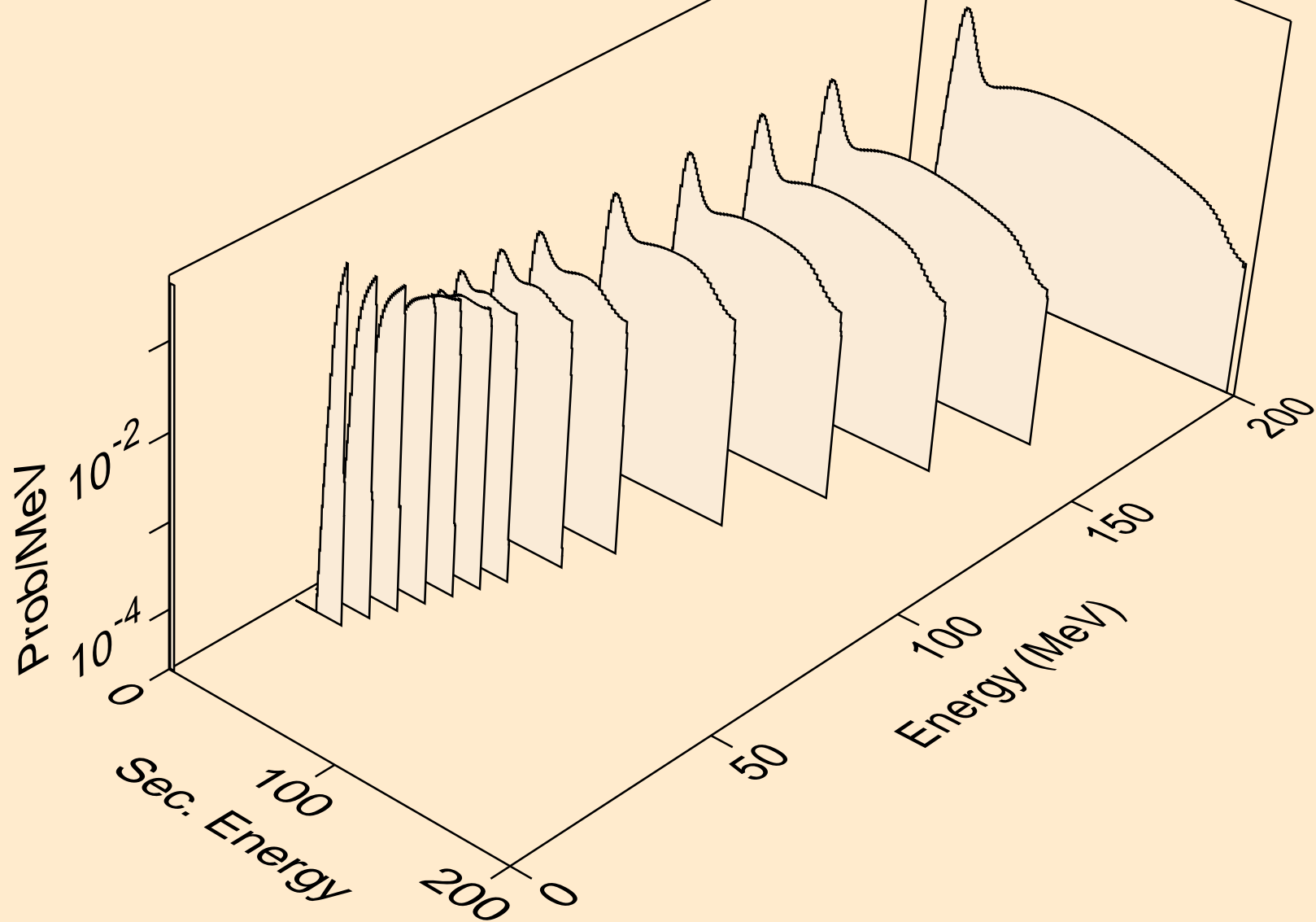

AC224 DEUTERON ACER TENDL-2024 LIBRARY; T=0.K  
he3s from (d,n\*)he3

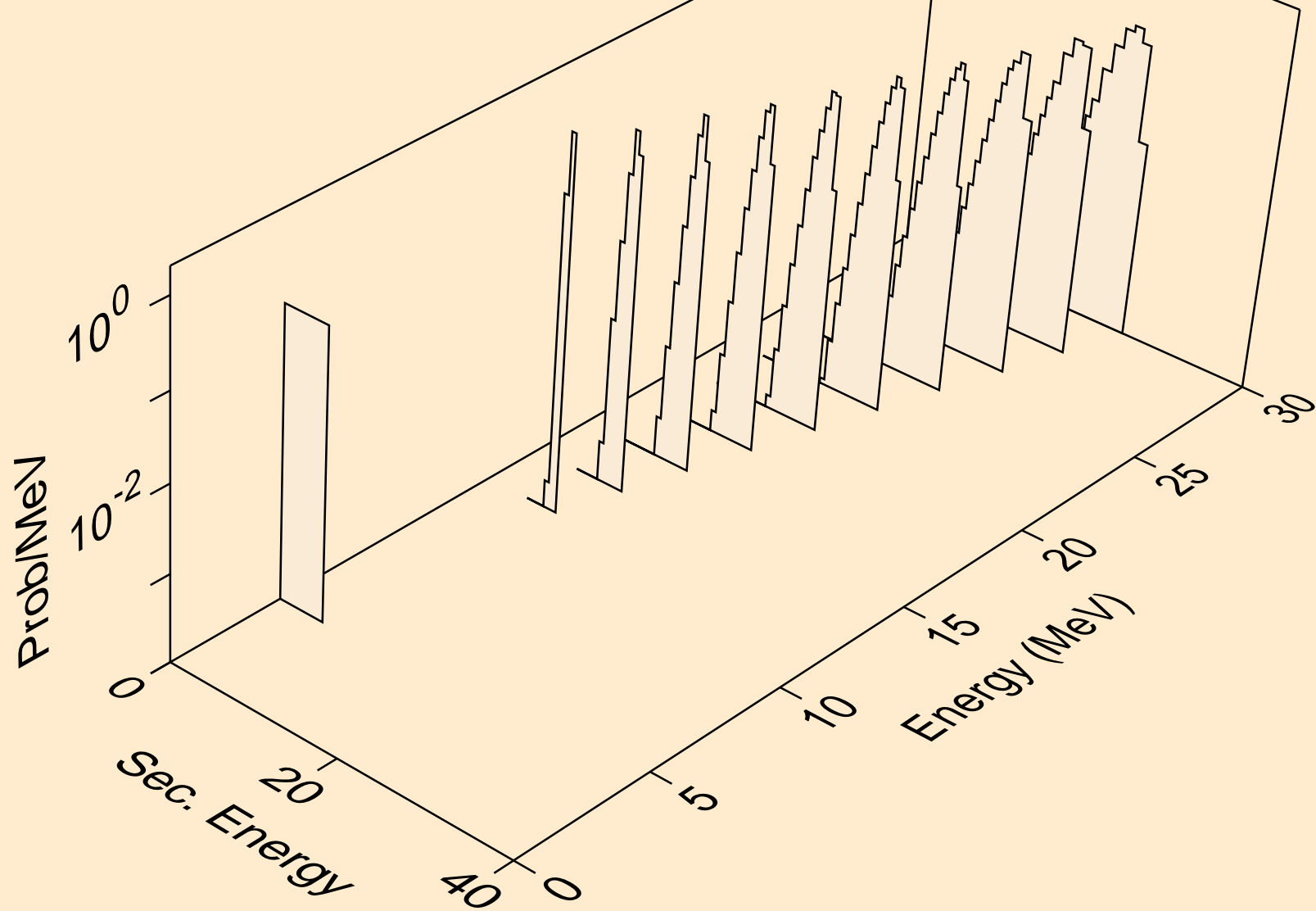

AC224 DEUTERON ACER TENDL-2024 LIBRARY; T=0.K  
he3s from (d,he3)

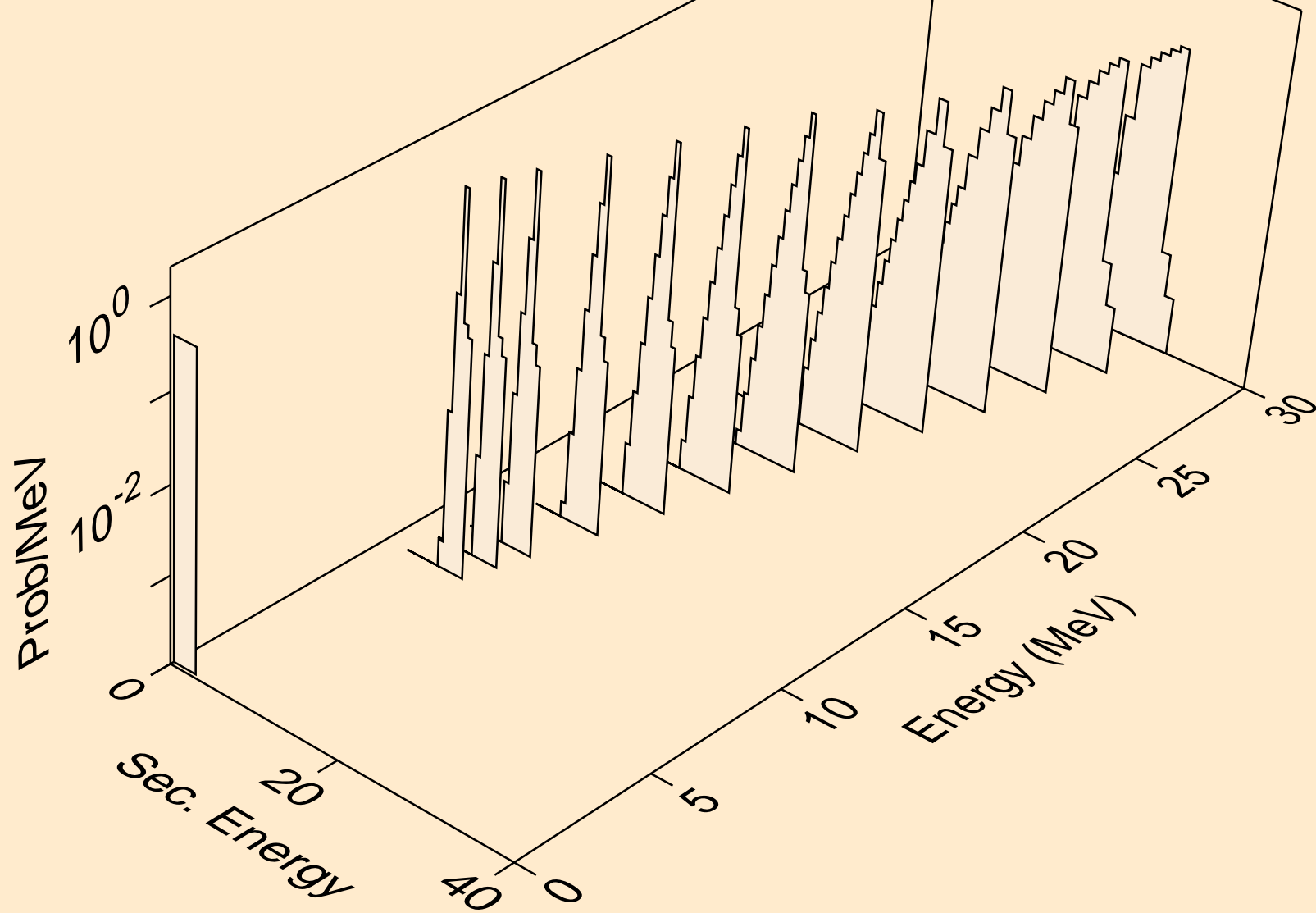

AC224 DEUTERON ACER TENDL-2024 LIBRARY; T=0.K  
alphas from (d,x)

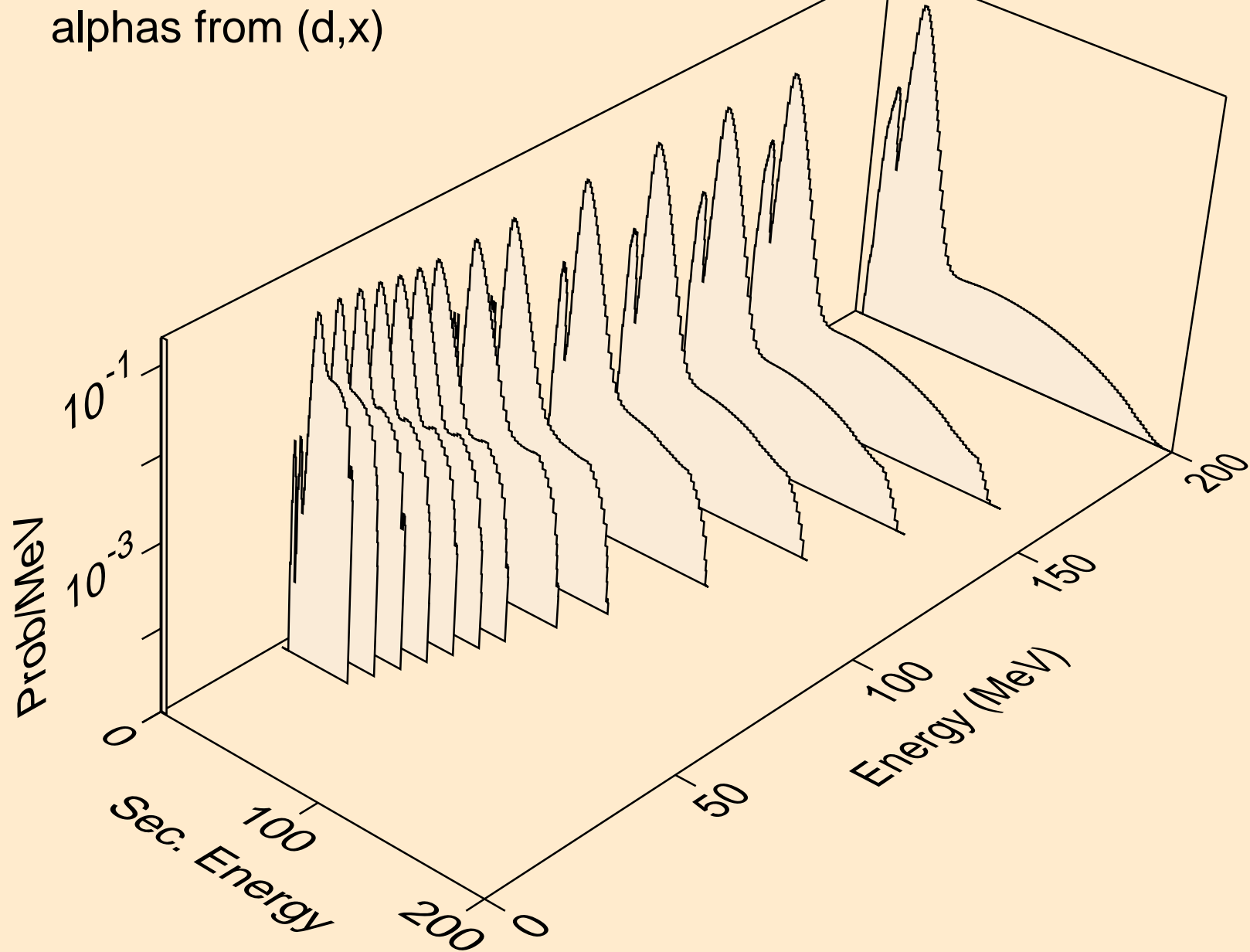

AC224 DEUTERON ACER TENDL-2024 LIBRARY; T=0.K  
alphas from (d,n\*)a

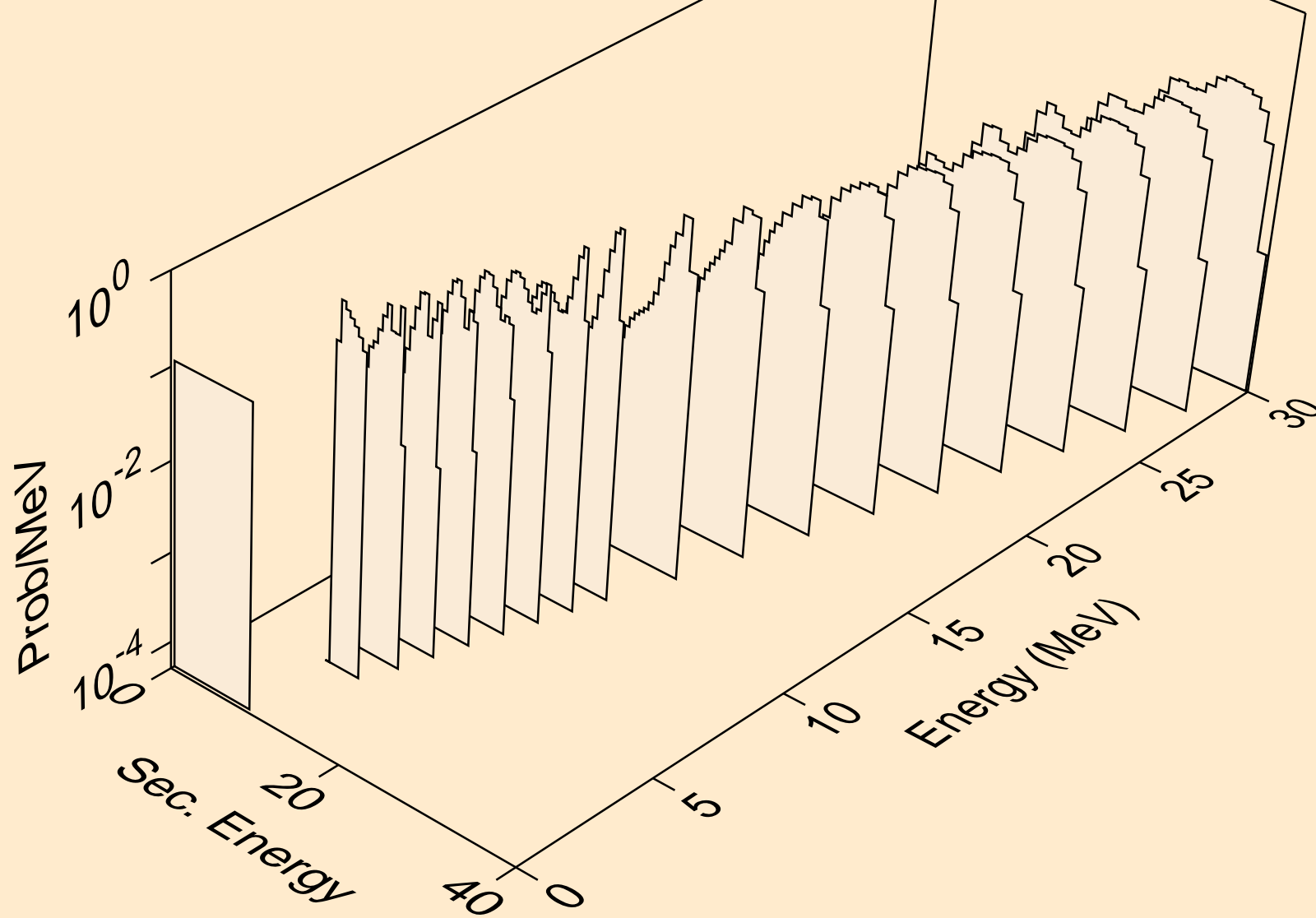

AC224 DEUTERON ACER TENDL-2024 LIBRARY; T=0.K  
alphas from (d,2n)a

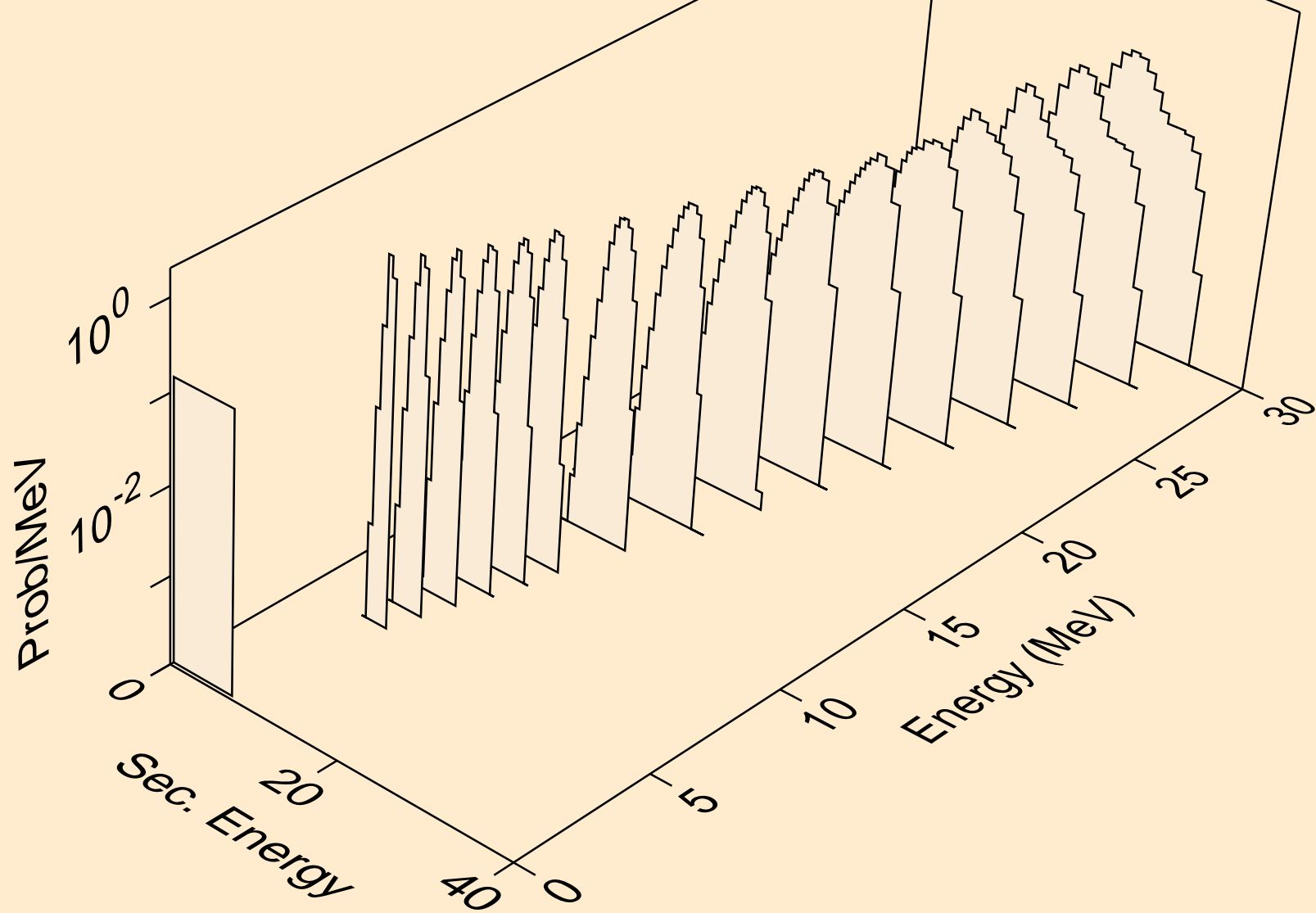

AC224 DEUTERON ACER TENDL-2024 LIBRARY; T=0.K  
alphas from (d,3n)a

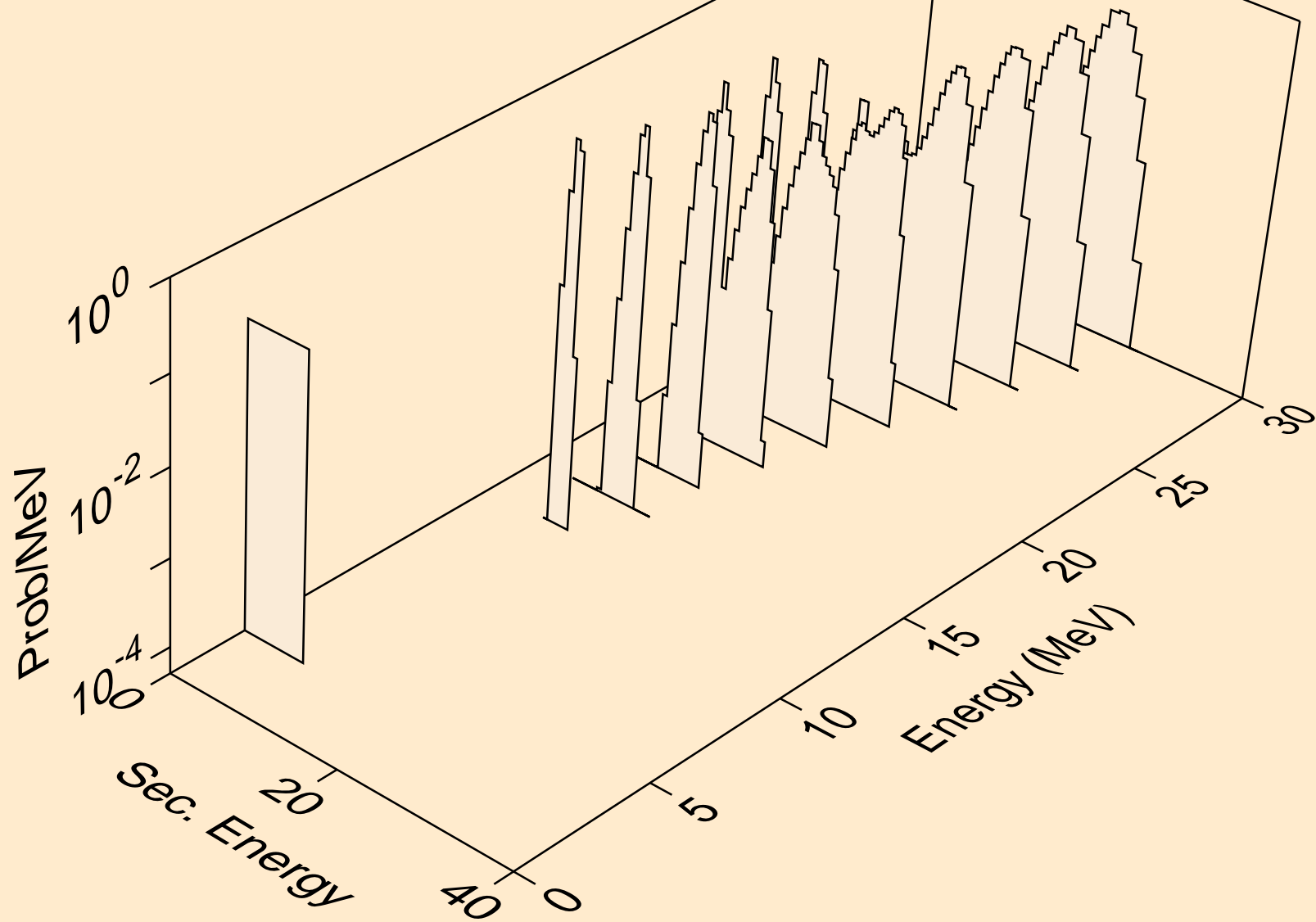

AC224 DEUTERON ACER TENDL-2024 LIBRARY; T=0.K  
alphas from (d,n\*)2a

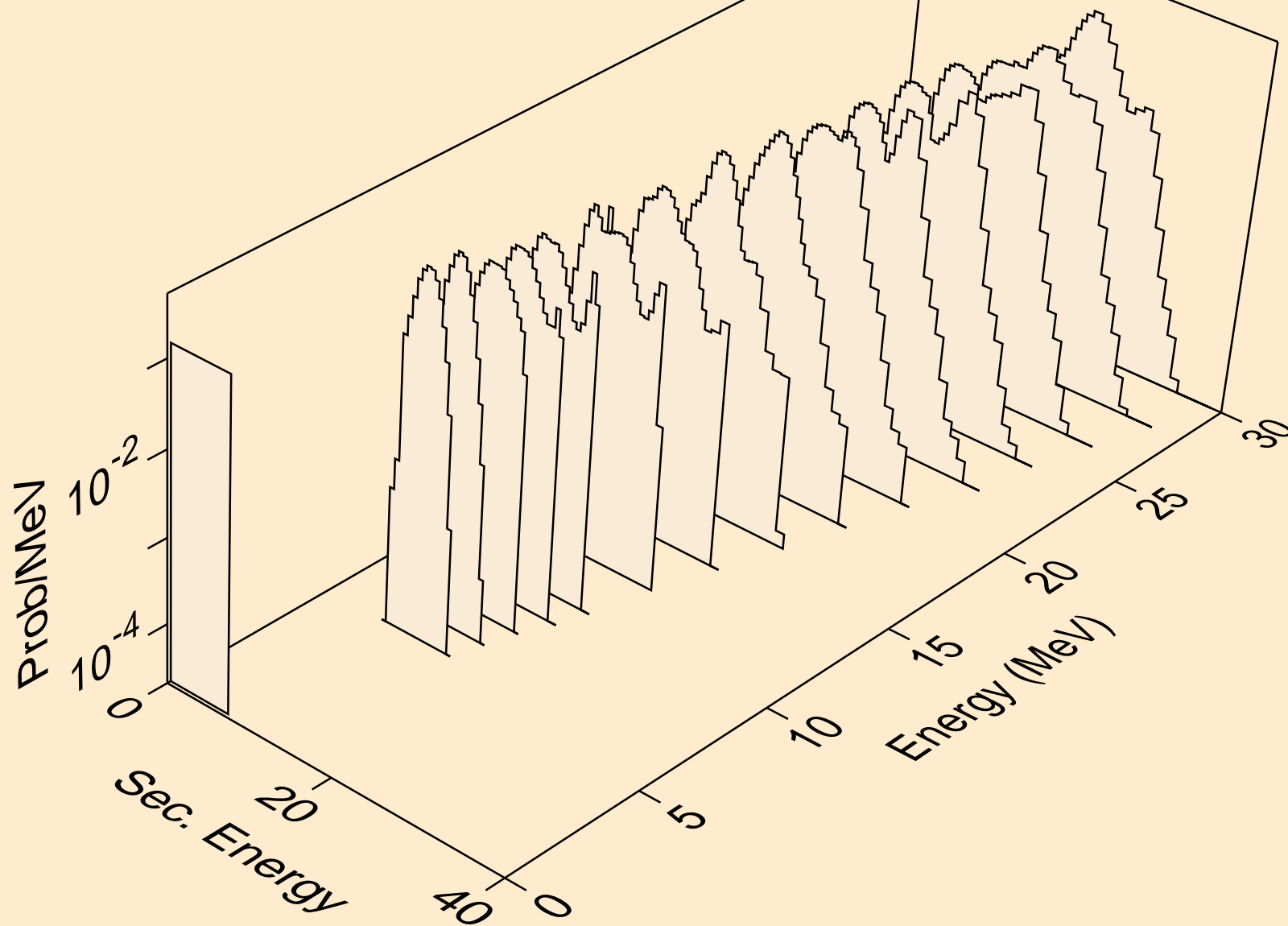

AC224 DEUTERON ACER TENDL-2024 LIBRARY; T=0.K  
alphas from (d,2n)2a

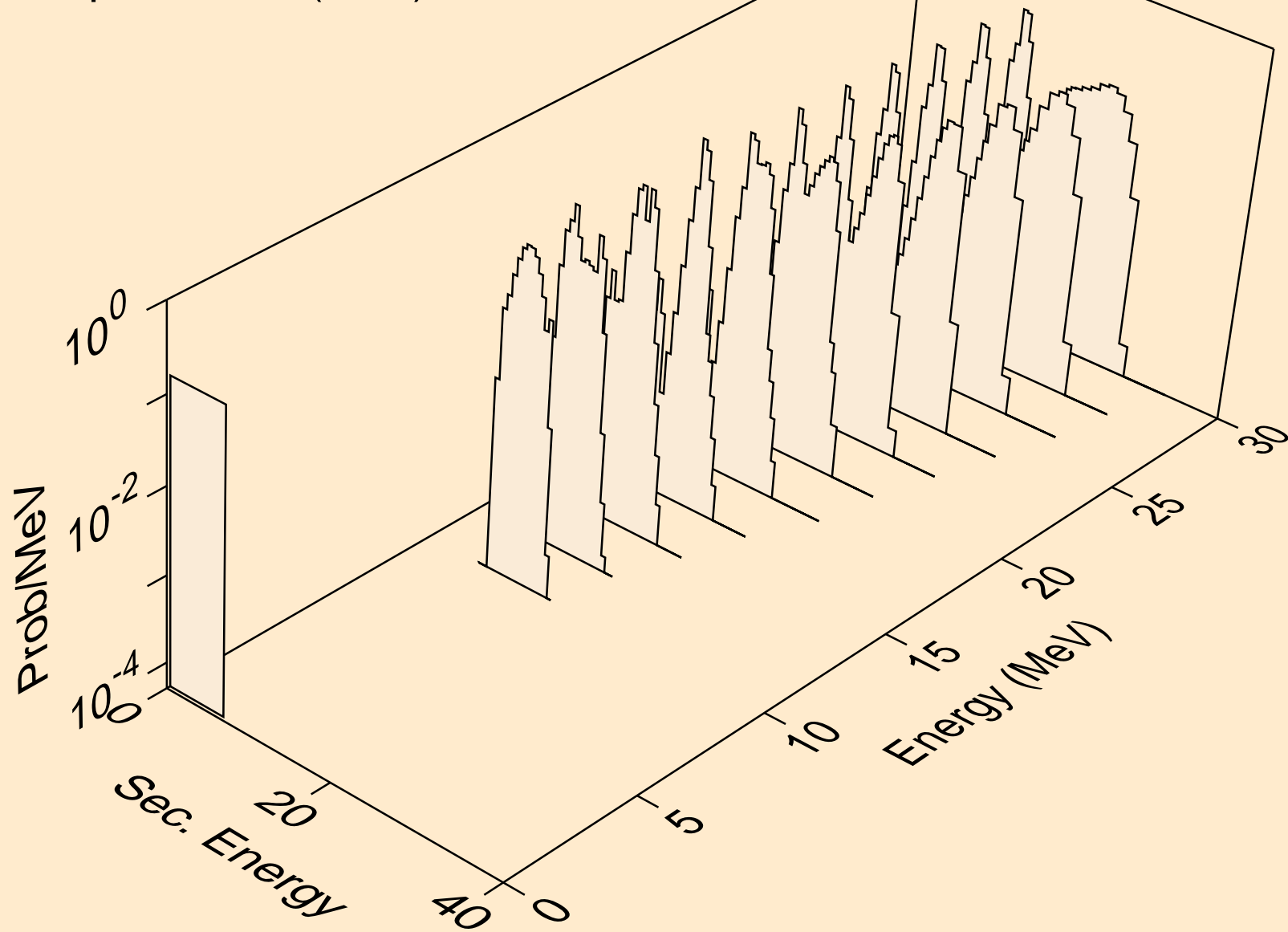

AC224 DEUTERON ACER TENDL-2024 LIBRARY; T=0.K  
alphas from (d,npa)

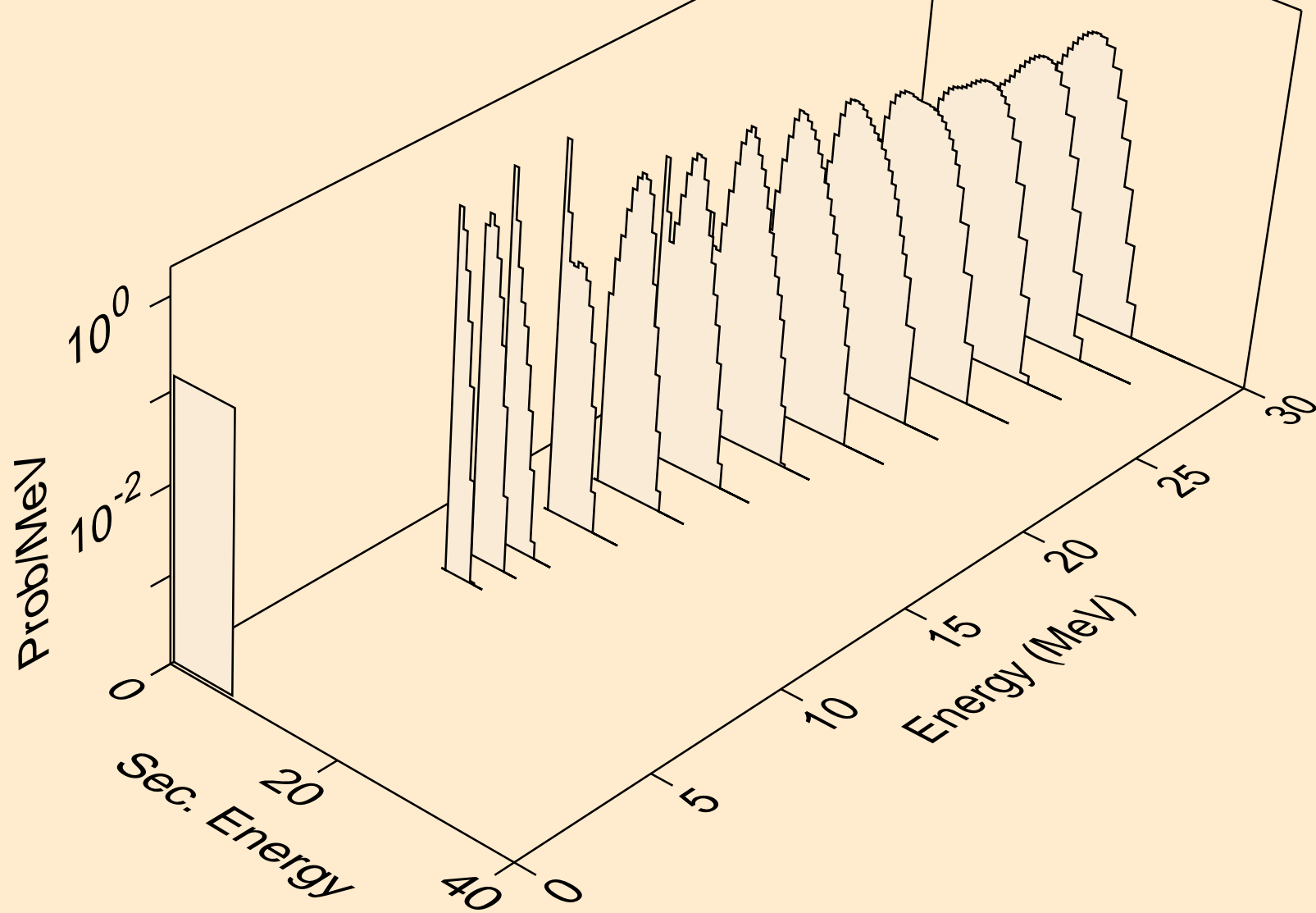

AC224 DEUTERON ACER TENDL-2024 LIBRARY; T=0.K  
alphas from (d,a)

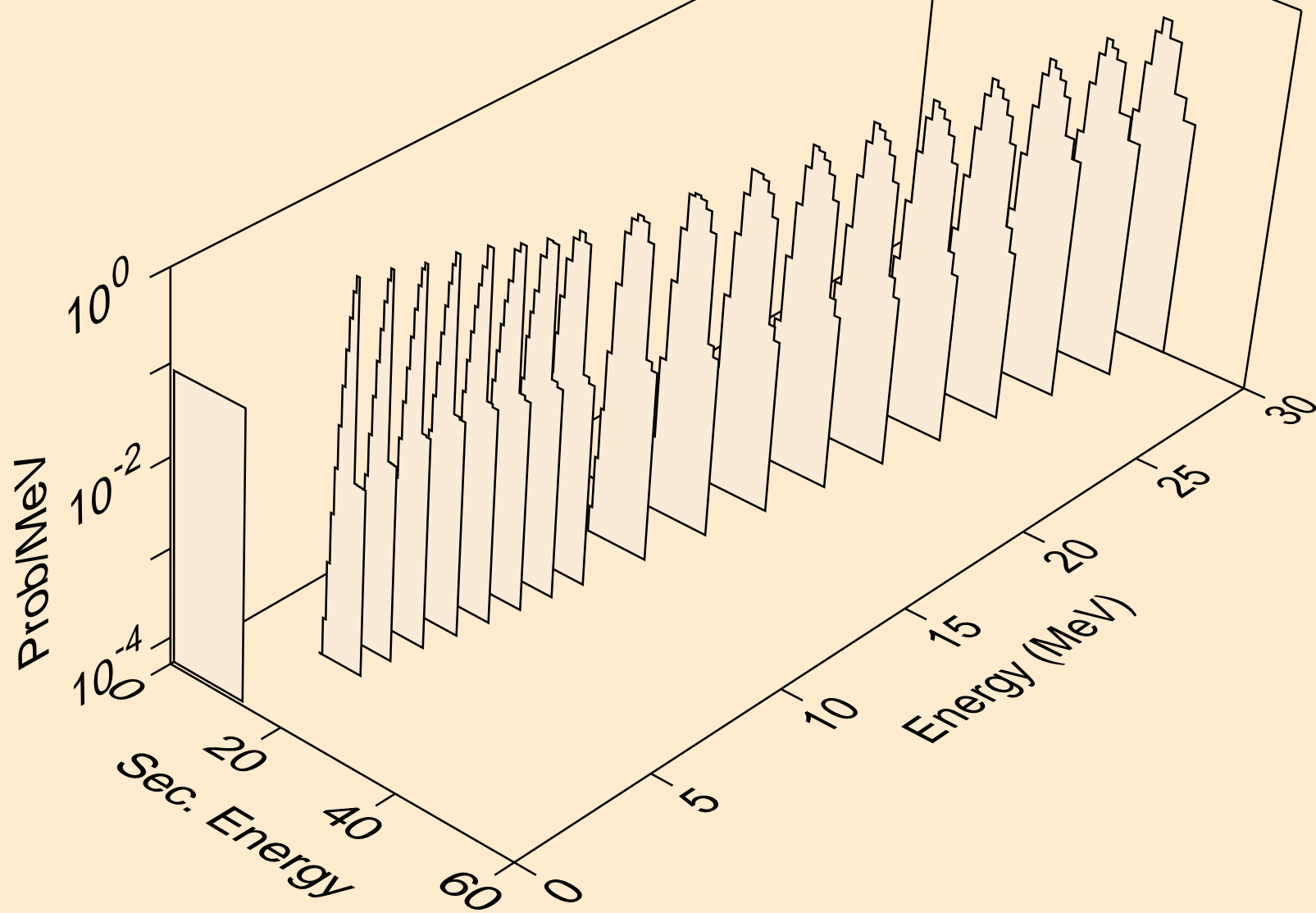

AC224 DEUTERON ACER TENDL-2024 LIBRARY; T=0.K  
alphas from (d,2a)

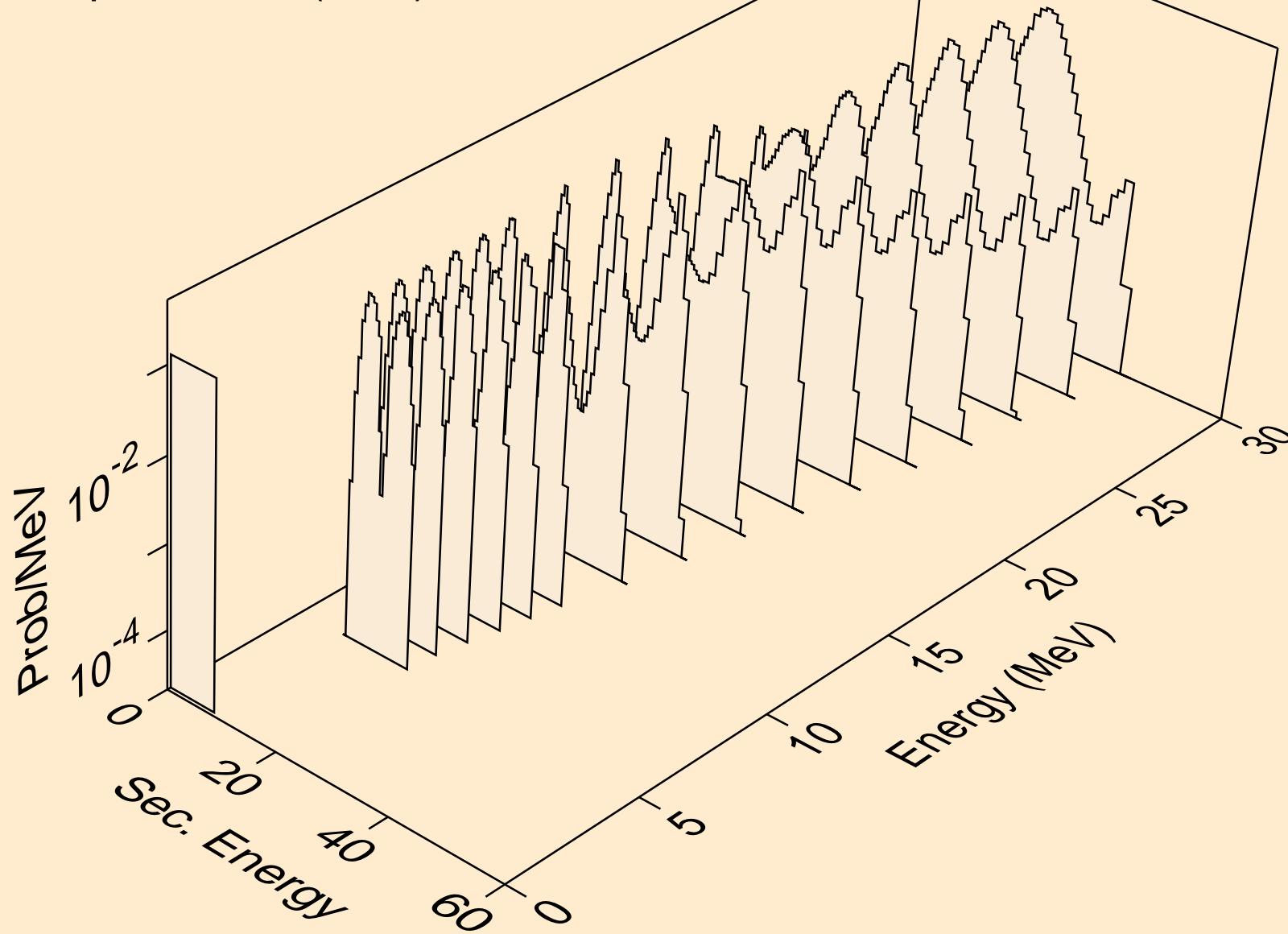

AC224 DEUTERON ACER TENDL-2024 LIBRARY; T=0.K  
alphas from (d,pa)

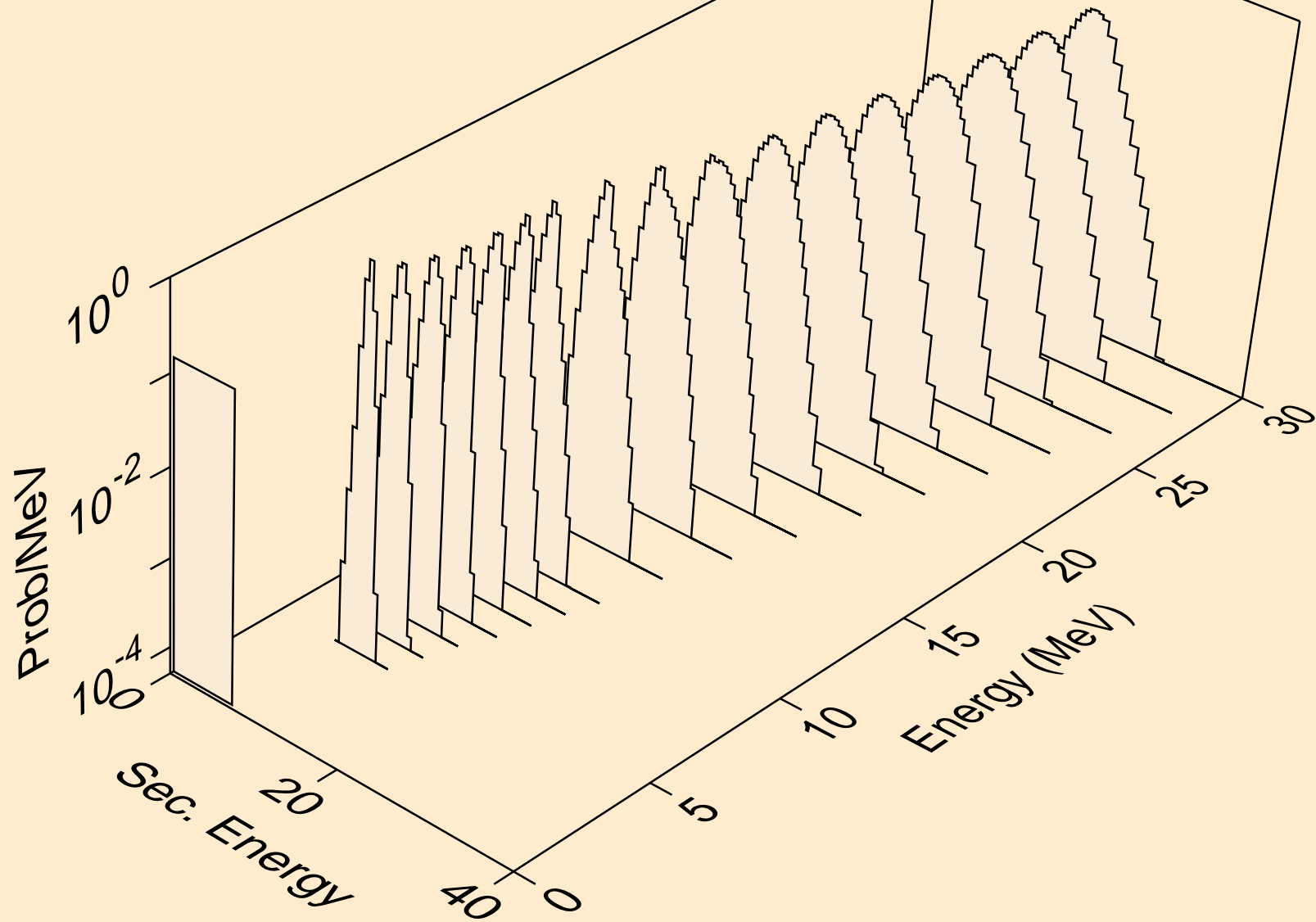

AC224 DEUTERON ACER TENDL-2024 LIBRARY; T=0.K  
alphas from (d,da)

