

PU233 DEUTERON ACER TENDL-2024 LIBRARY; T=0.K
Principal cross sections

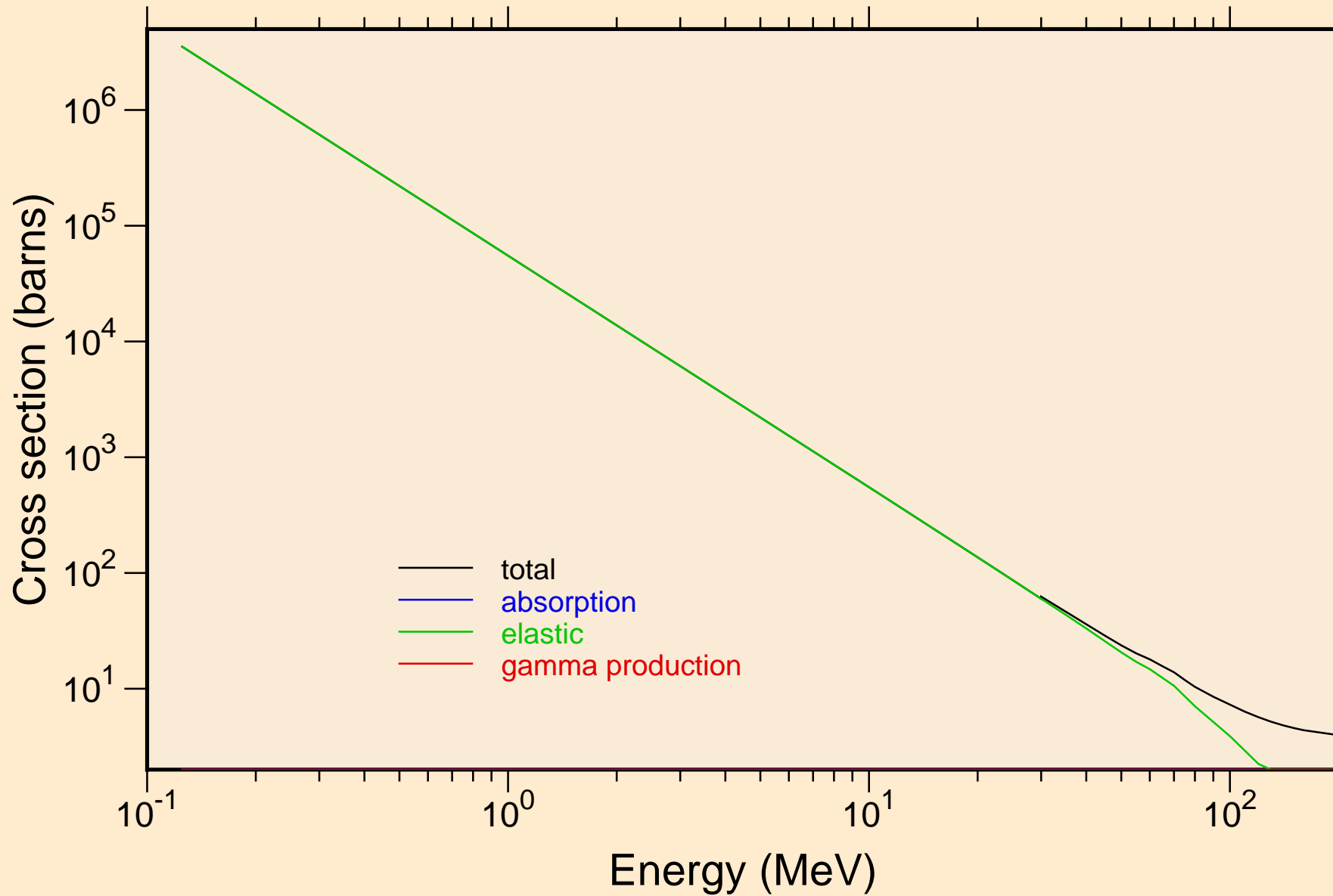

PU233 DEUTERON ACER TENDL-2024 LIBRARY; T=0.K
Heating

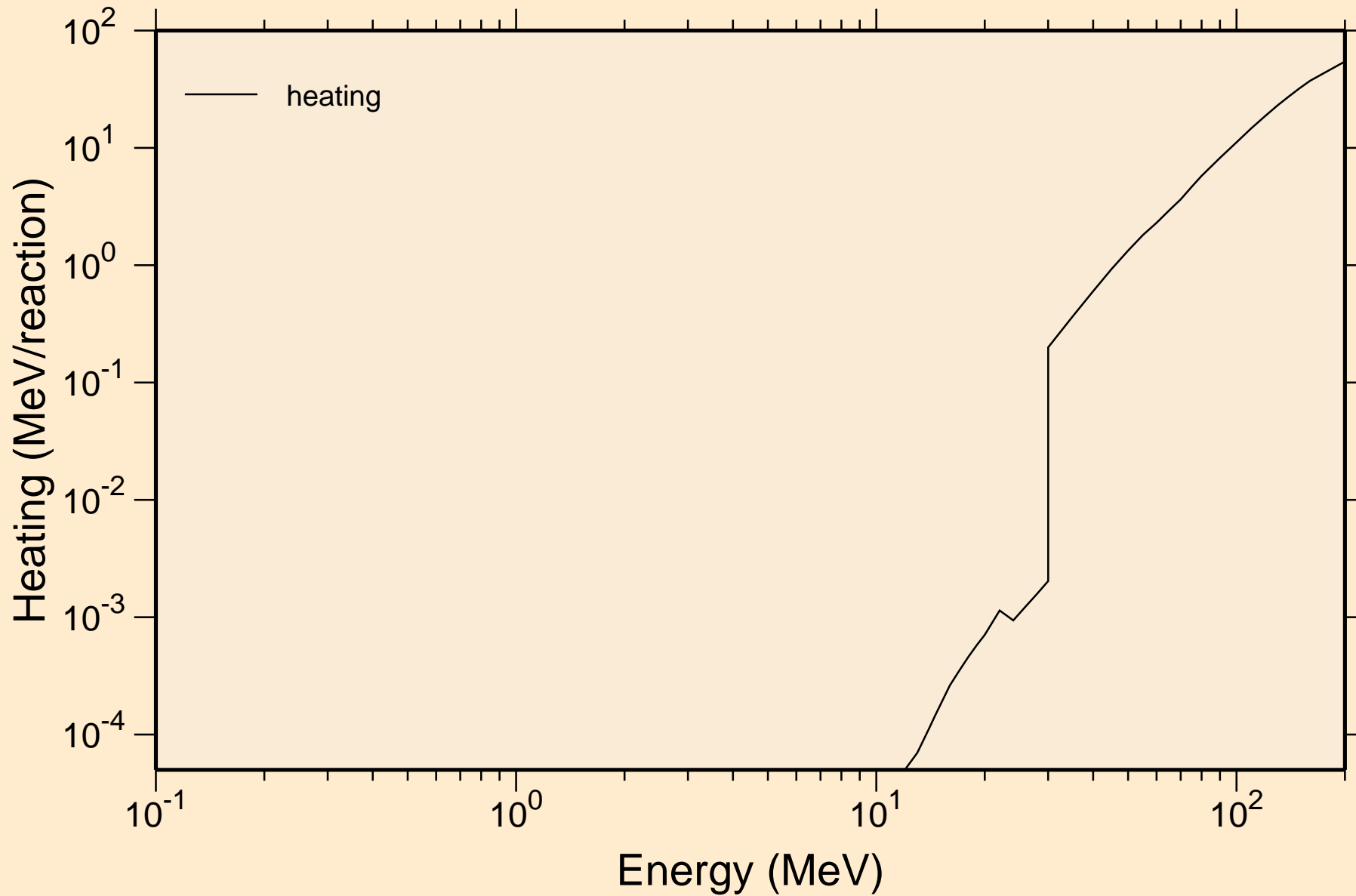

PU233 DEUTERON ACER TENDL-2024 LIBRARY; T=0.K
Principal cross sections

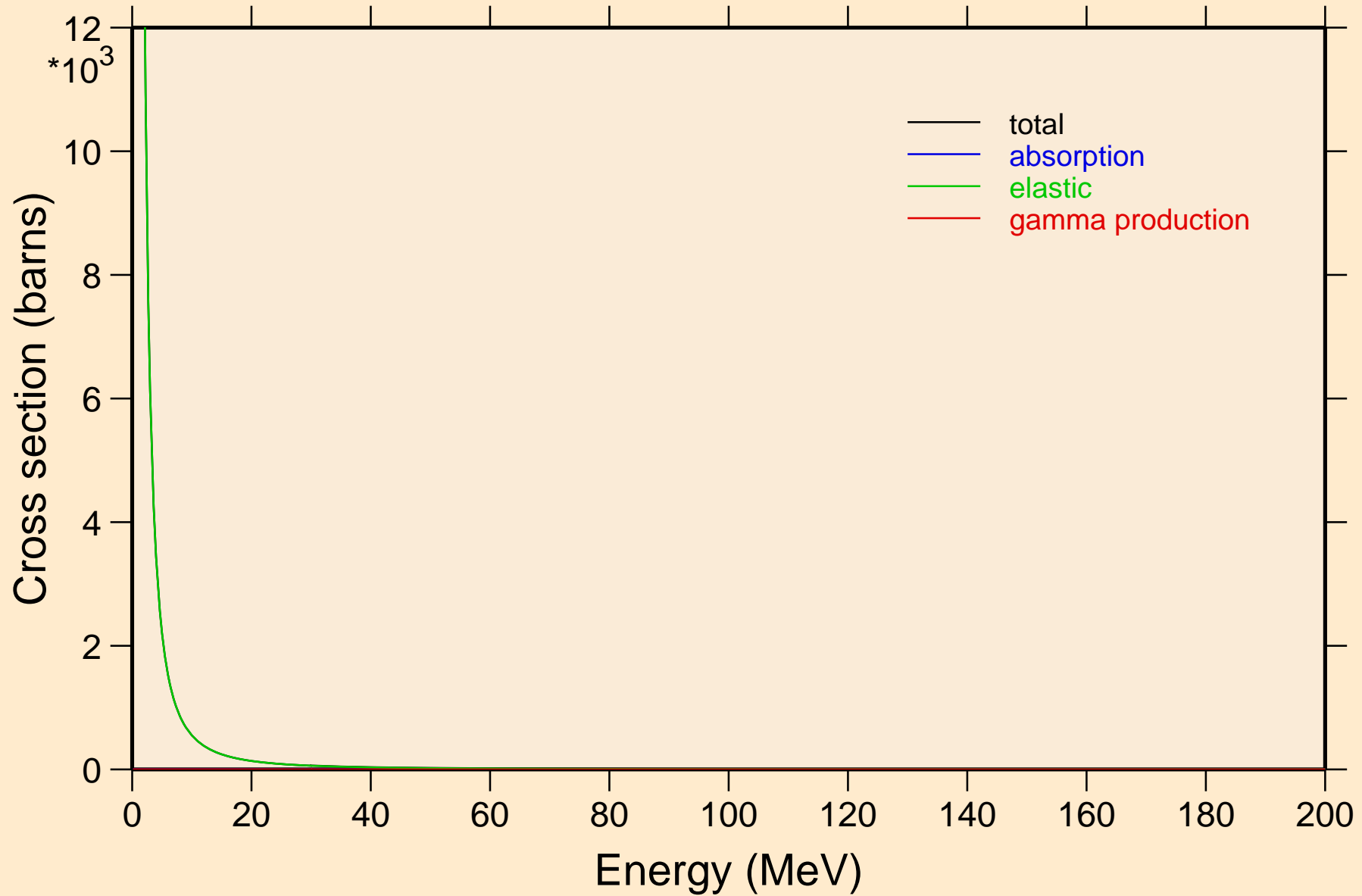

PU233 DEUTERON ACER TENDL-2024 LIBRARY; T=0.K
Heating

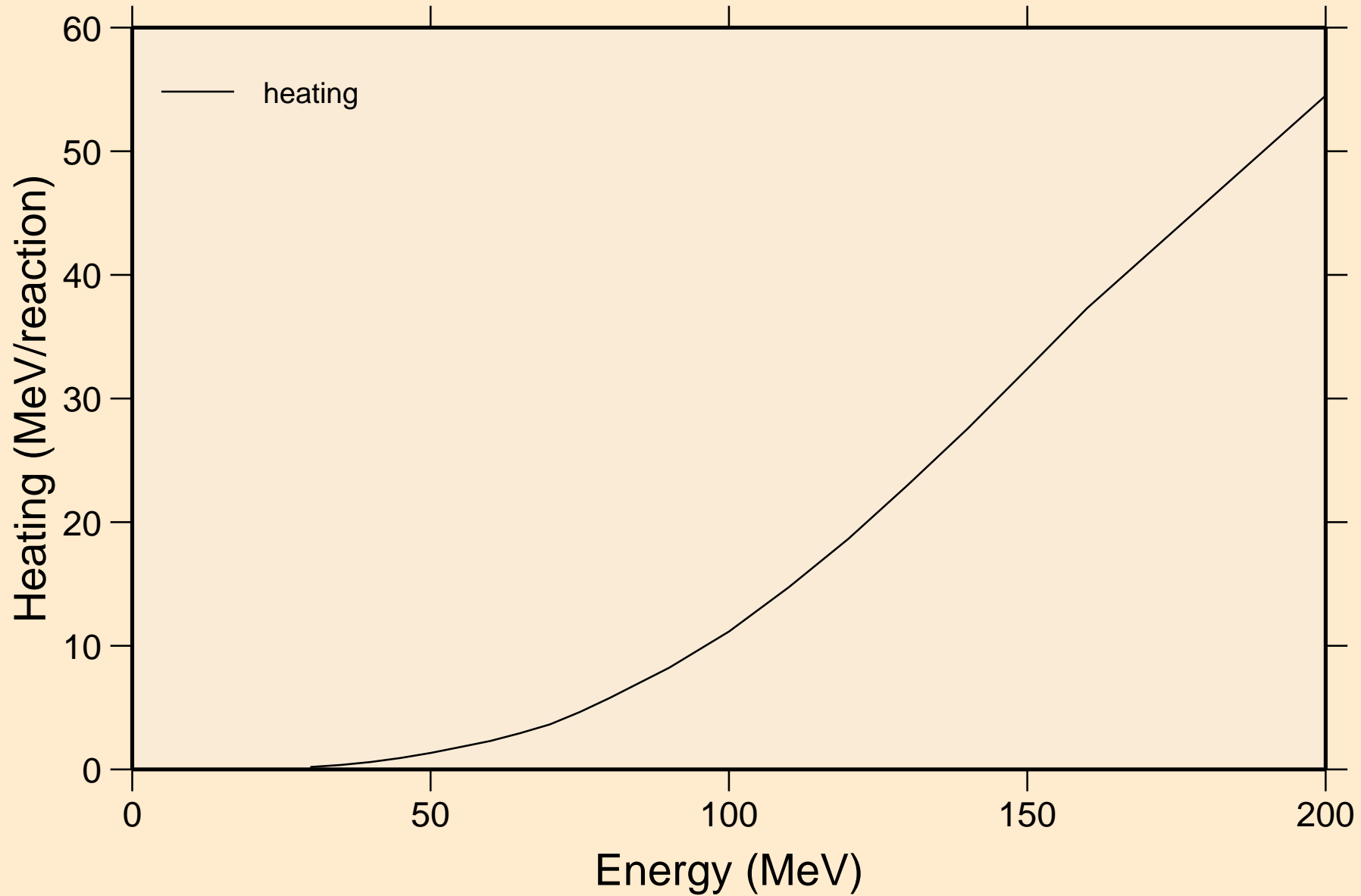

PU233 DEUTERON ACER TENDL-2024 LIBRARY; T=0.K
Threshold reactions

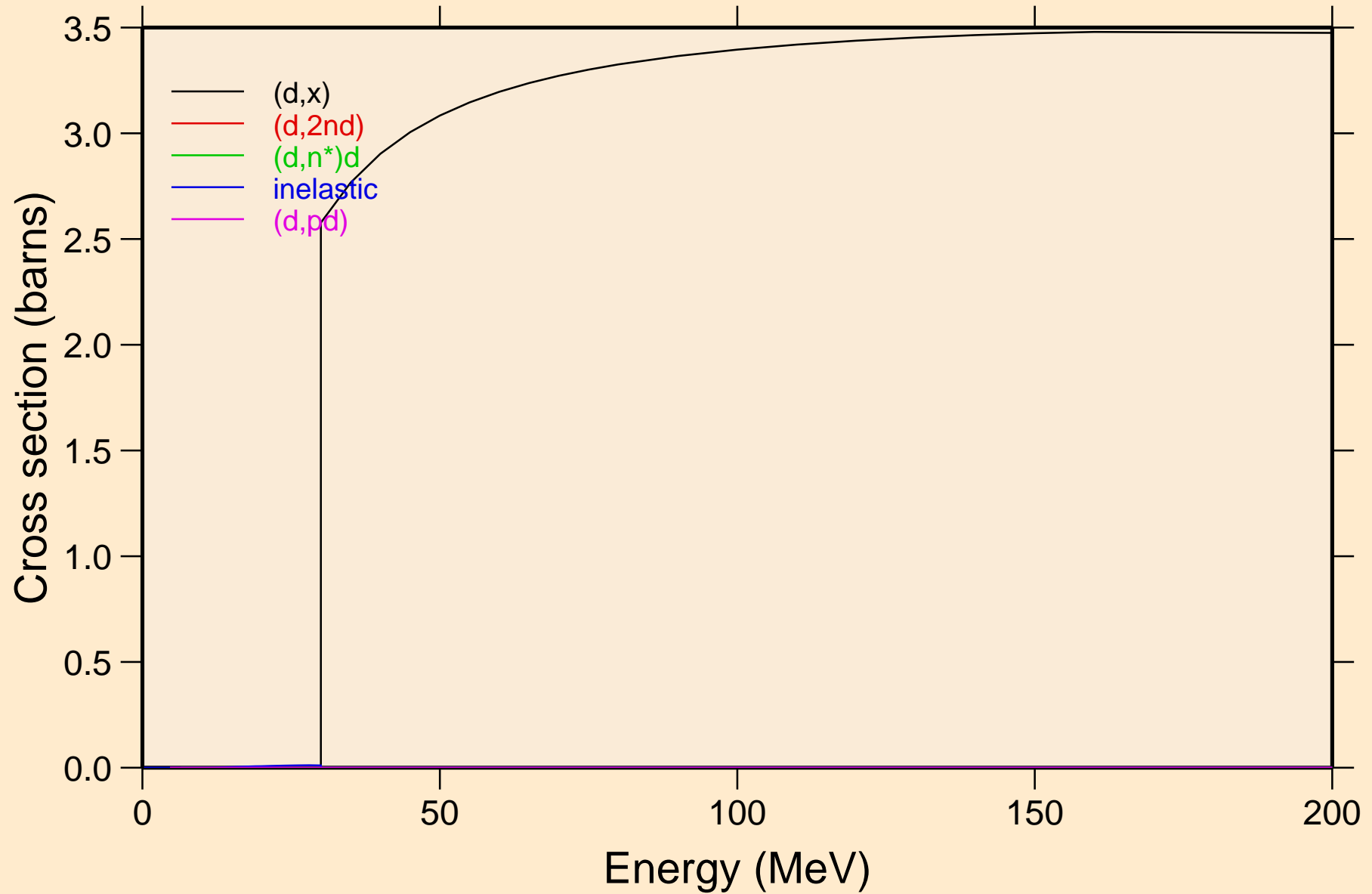

PU233 DEUTERON ACER TENDL-2024 LIBRARY; T=0.K
Threshold reactions

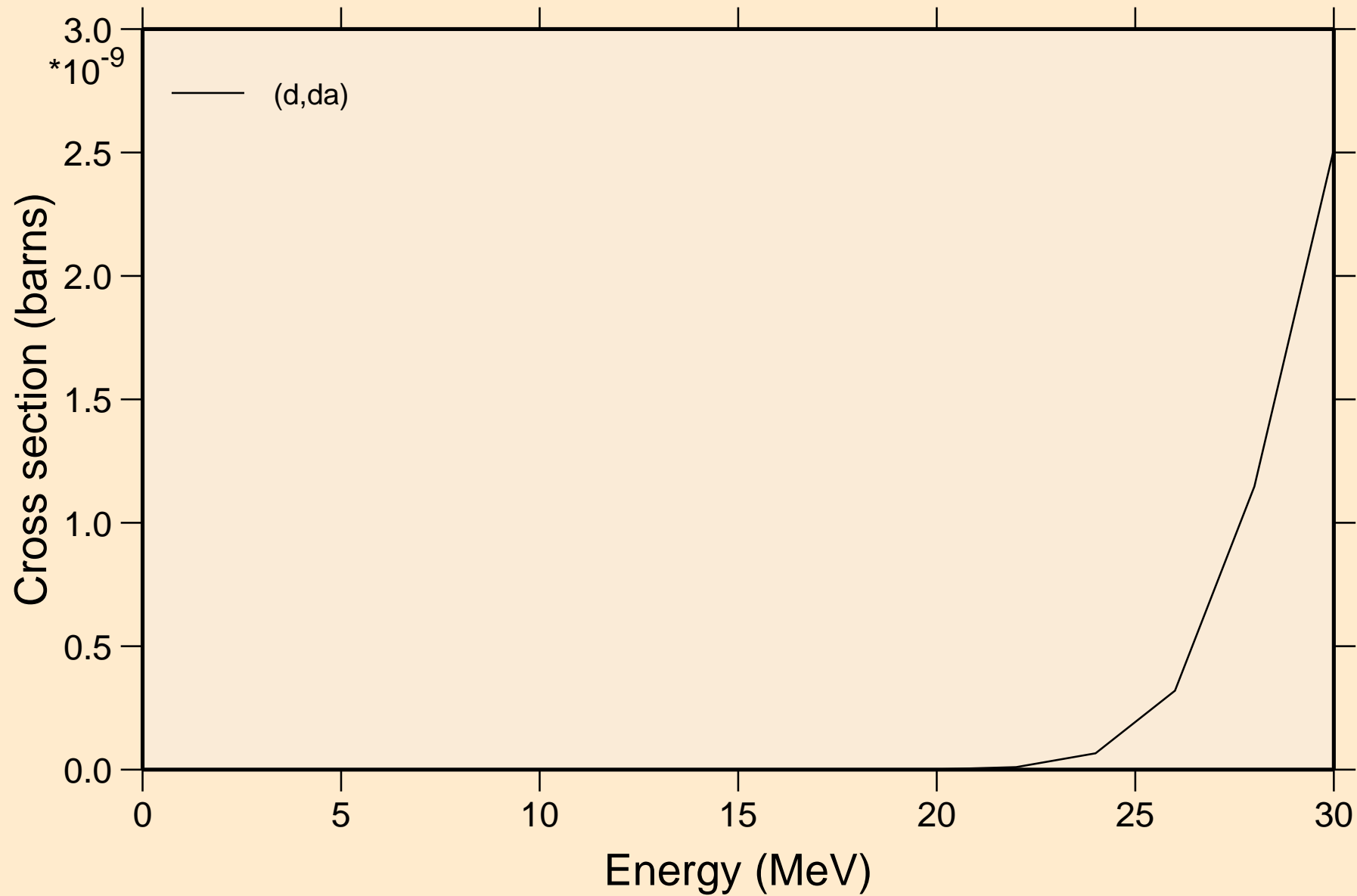

PU233 DEUTERON ACER TENDL-2024 LIBRARY; T=0.K
angular distribution for elastic

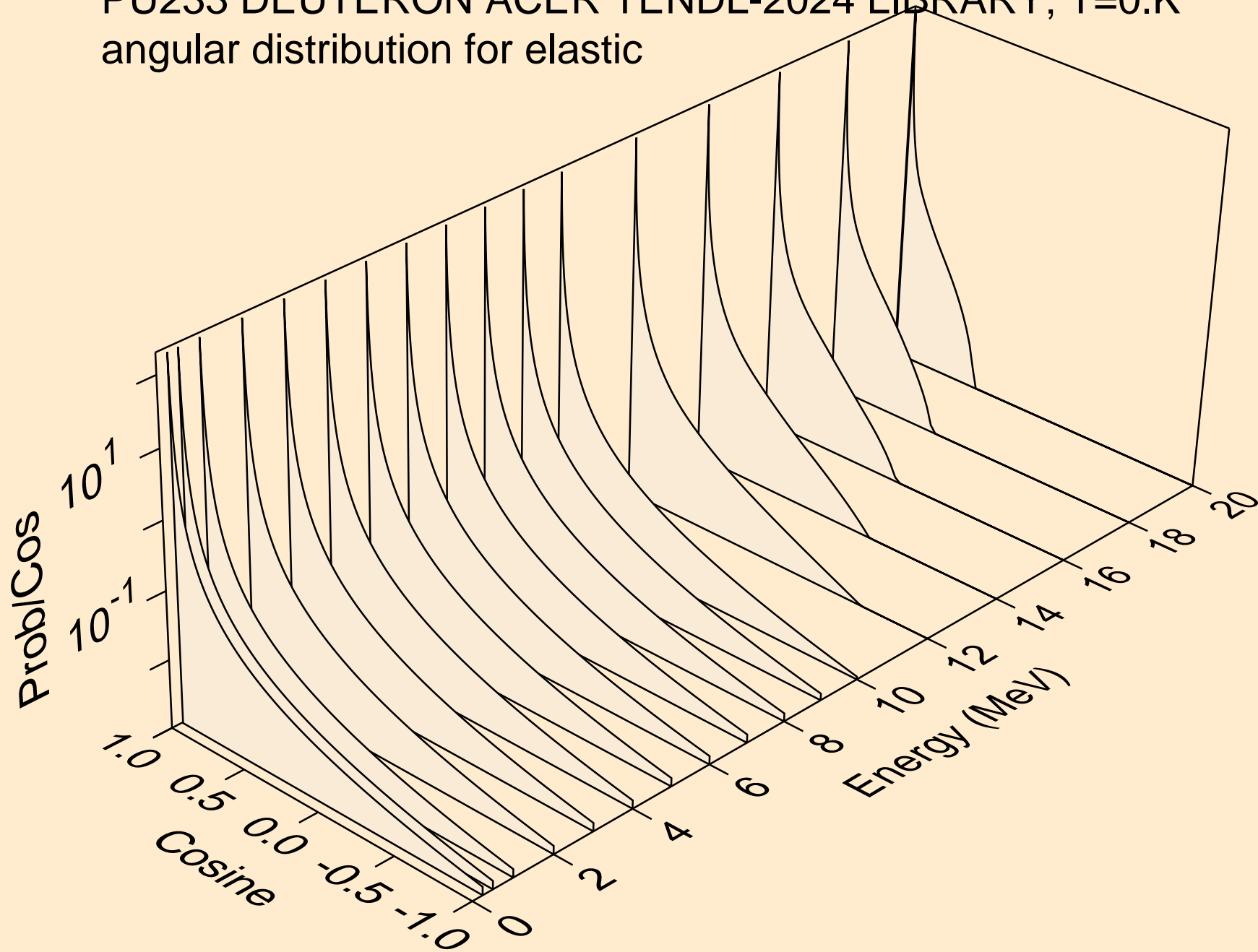

PU233 DEUTERON ACER TENDL-2024 LIBRARY; T=0.K
angular distribution for elastic

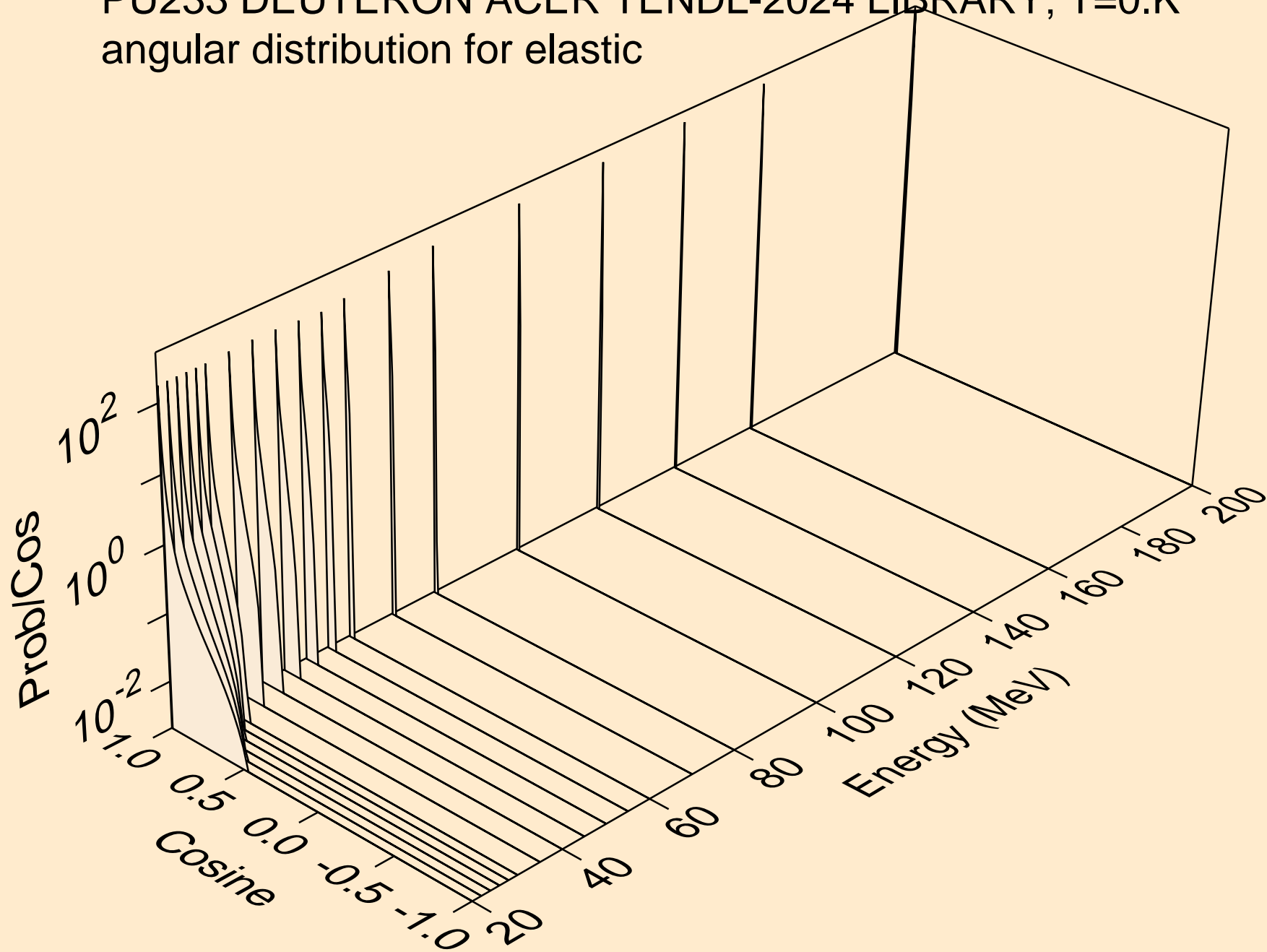

PU233 DEUTERON ACER TENDL-2024 LIBRARY; T=0.K
Deuteron emission for (d,x)

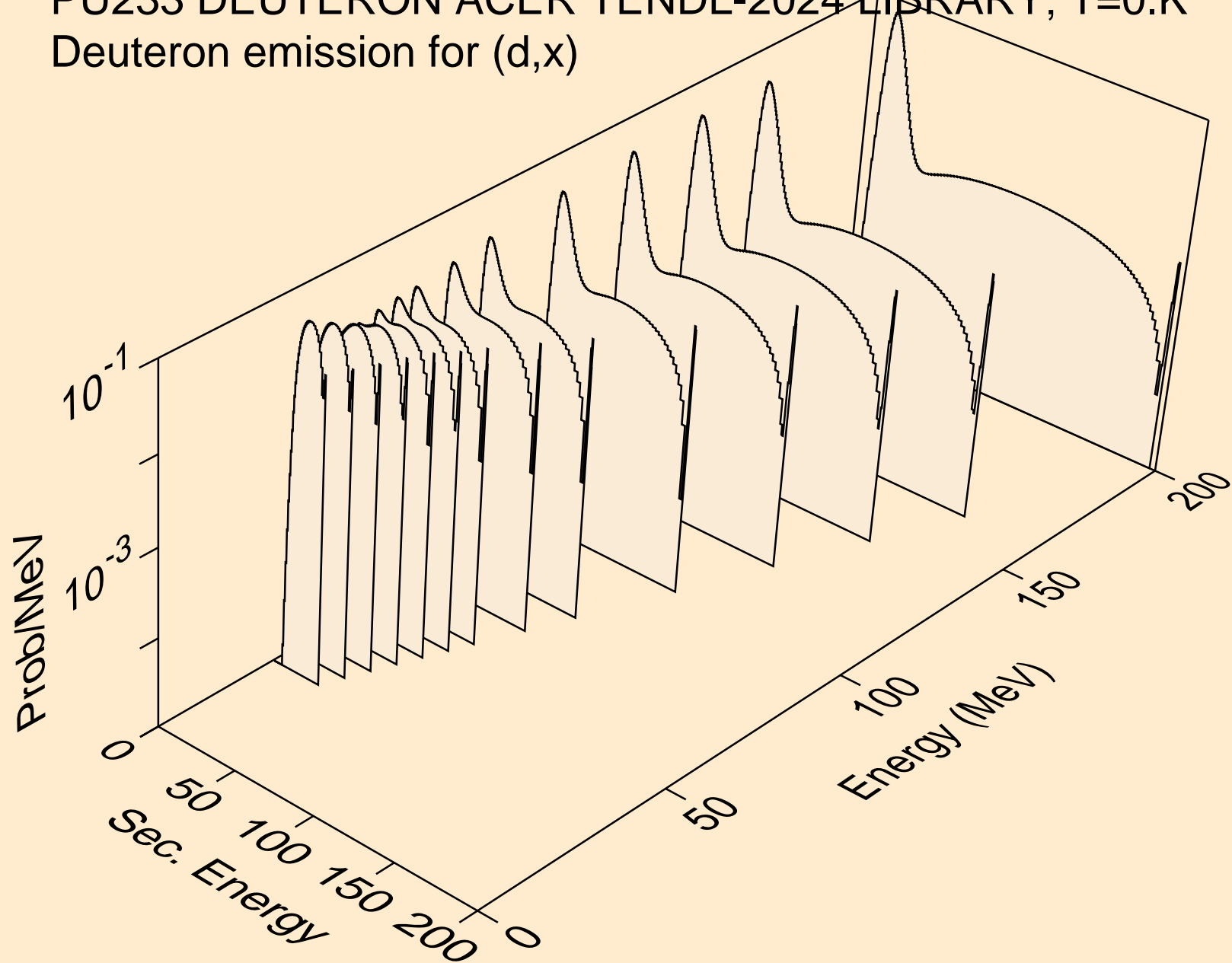

PU233 DEUTERON ACER TENDL-2024 LIBRARY; T=0.K
Deuteron emission for (d,2nd)

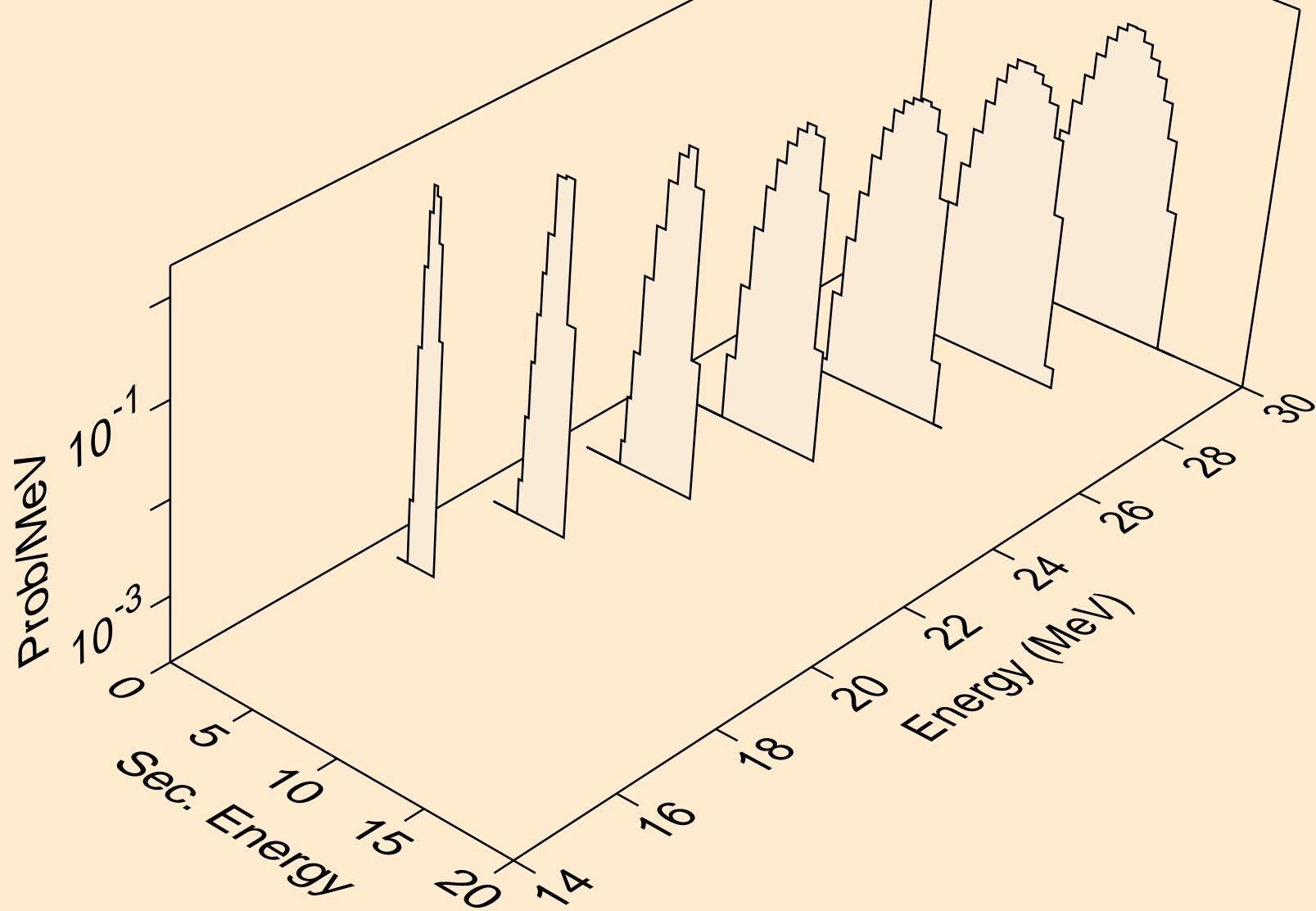

PU233 DEUTERON ACER TENDL-2024 LIBRARY; T=0.K
Deuteron emission for (d,n*)d

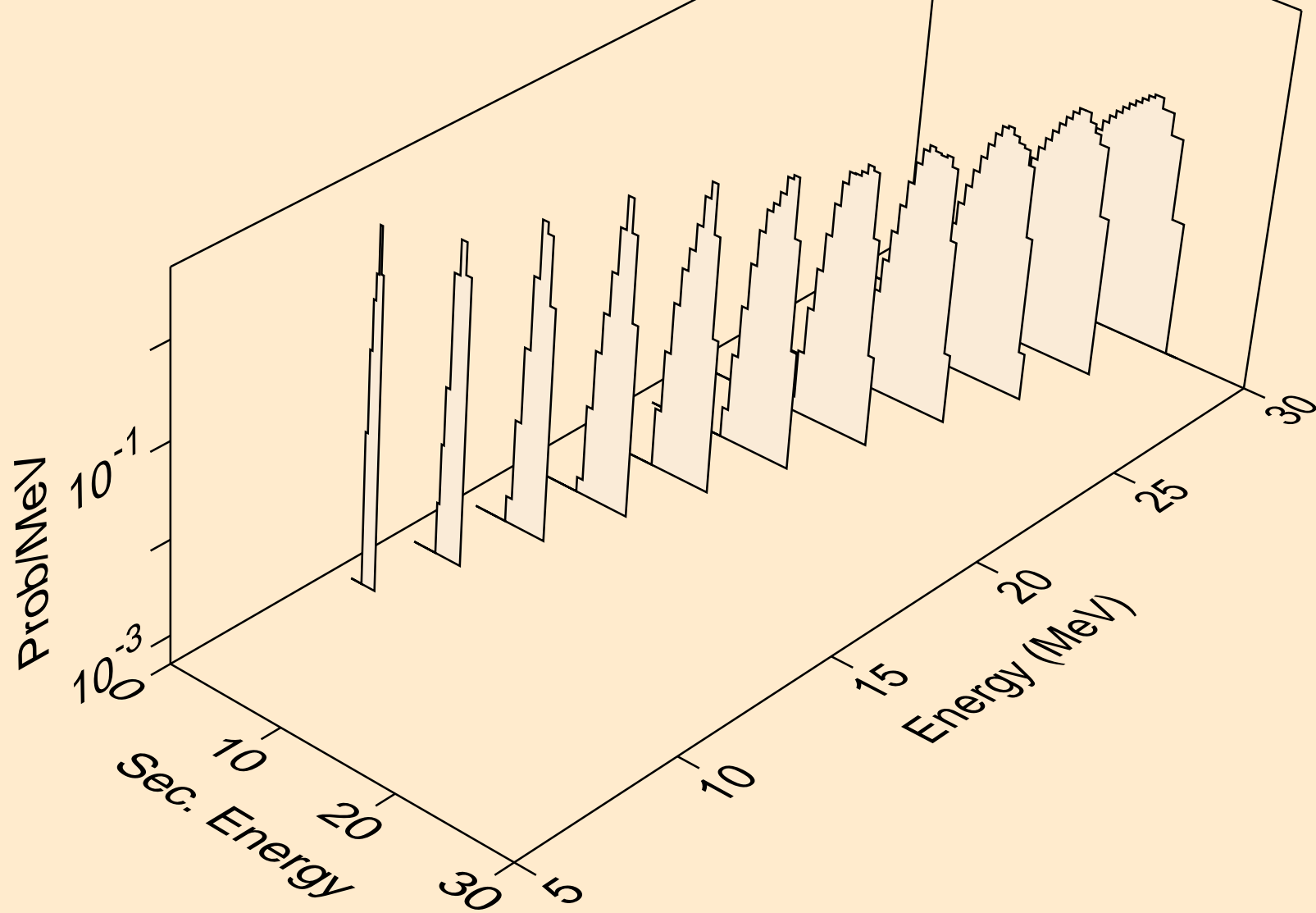

PU233 DEUTERON ACER TENDL-2024 LIBRARY; T=0.K
Deuteron emission for inelastic

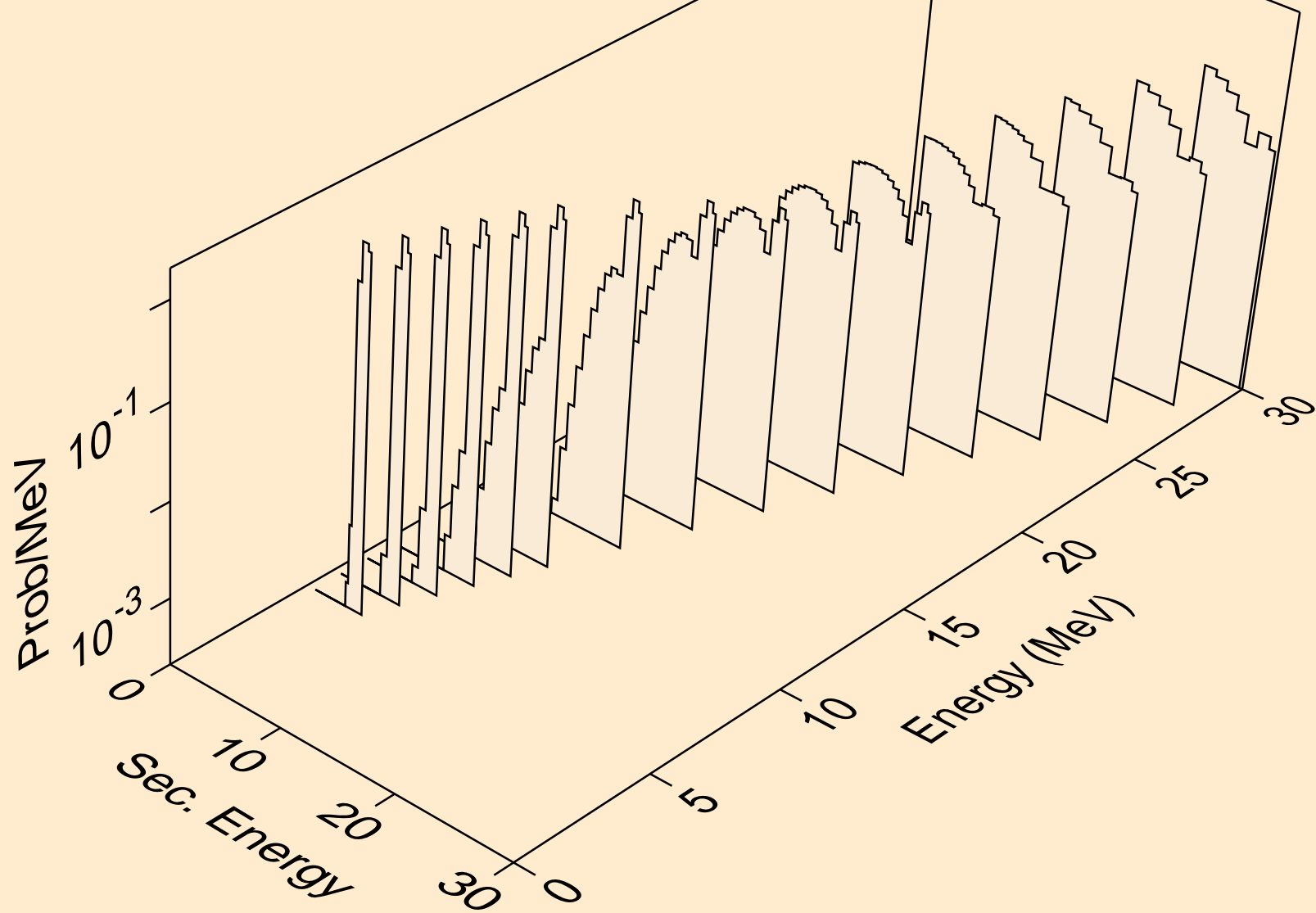

PU233 DEUTERON ACER TENDL-2024 LIBRARY; T=0.K
Deuteron emission for (d,pd)

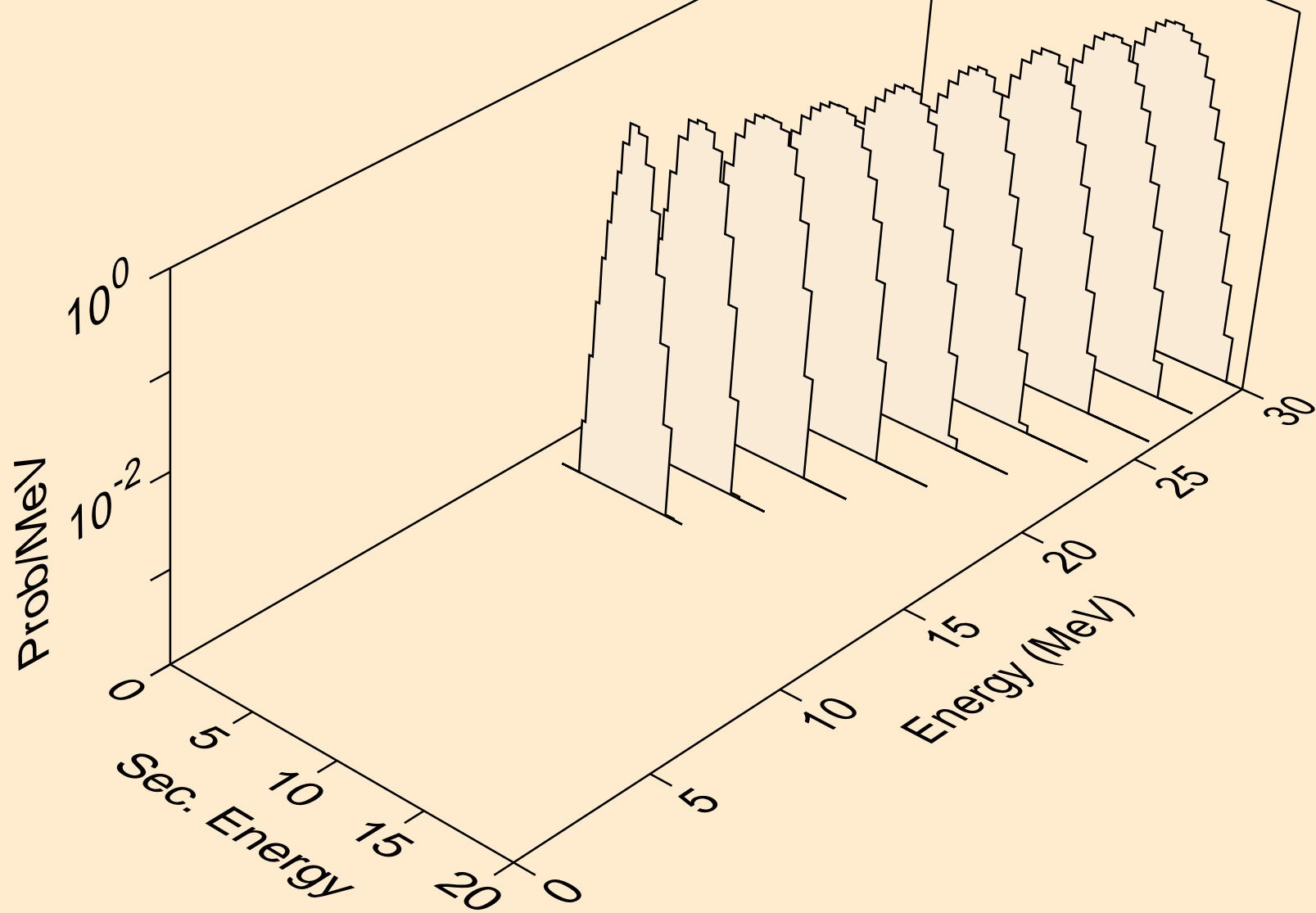

PU233 DEUTERON ACER TENDL-2024 LIBRARY; T=0.K
Deuteron emission for (d,da)

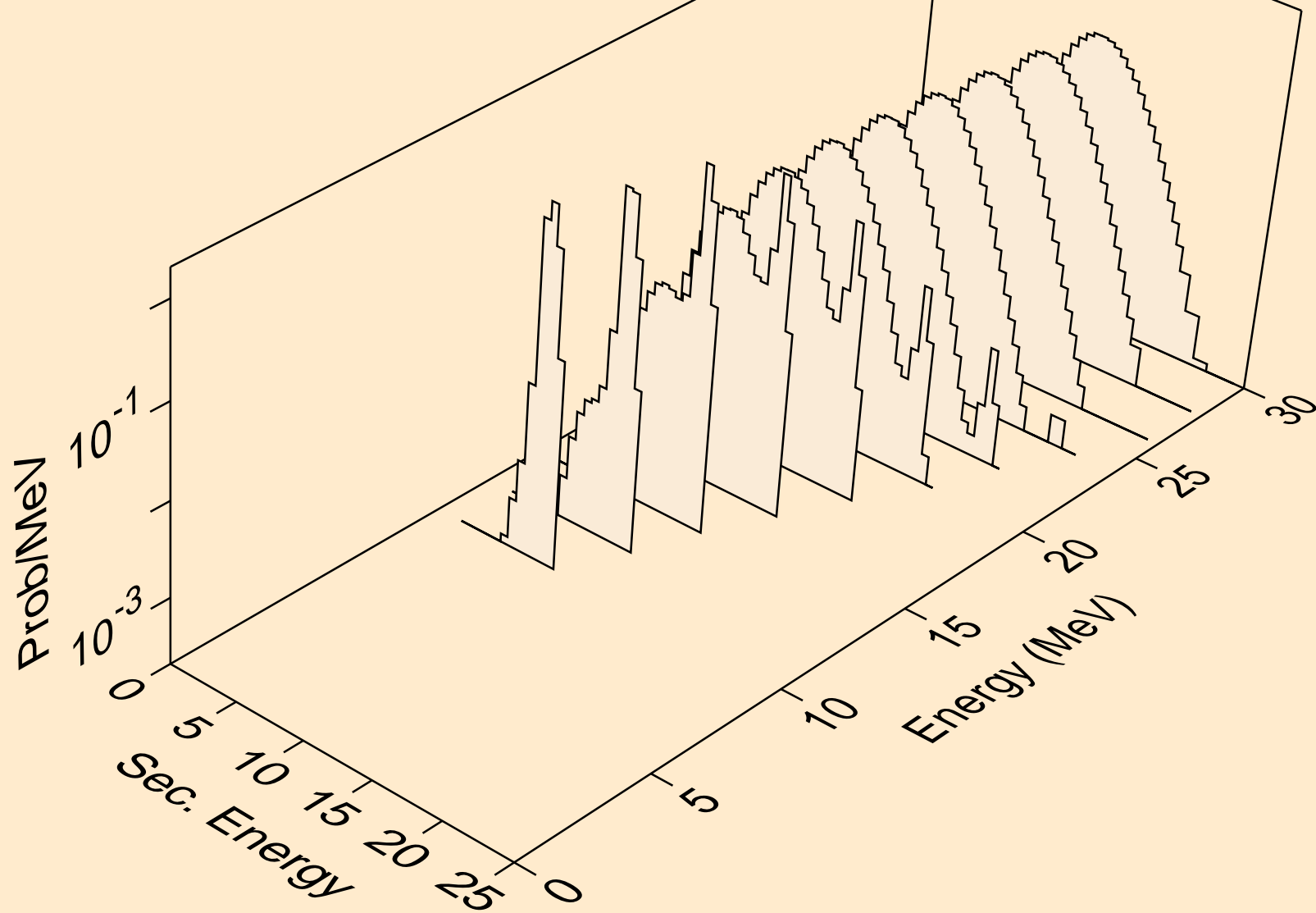

PU233 DEUTERON ACER TENDL-2024 LIBRARY; T=0.K
Photon emission for (z,n)

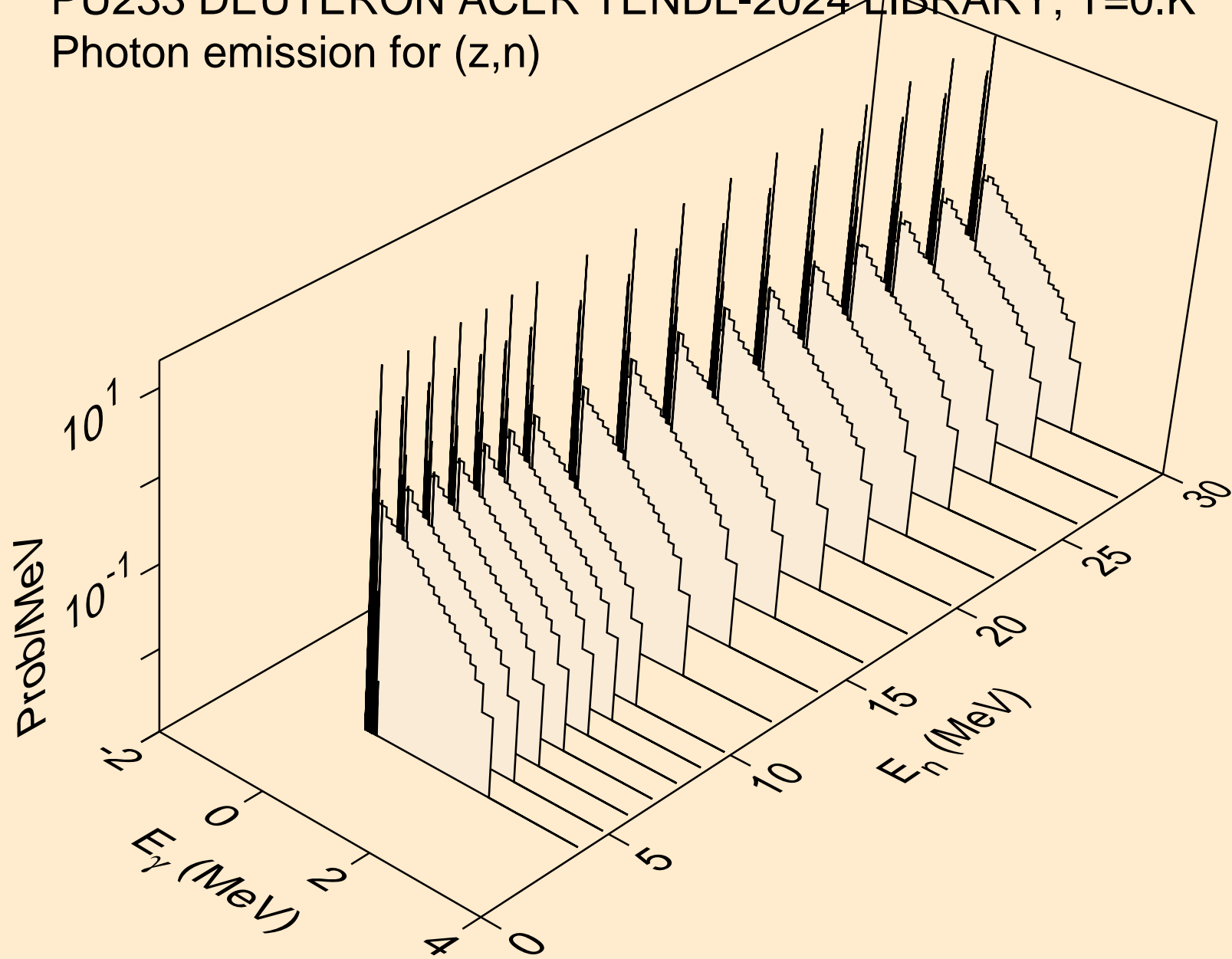

PU233 DEUTERON ACER TENDL-2024 LIBRARY; T=0.K
Photon emission for (z,x)

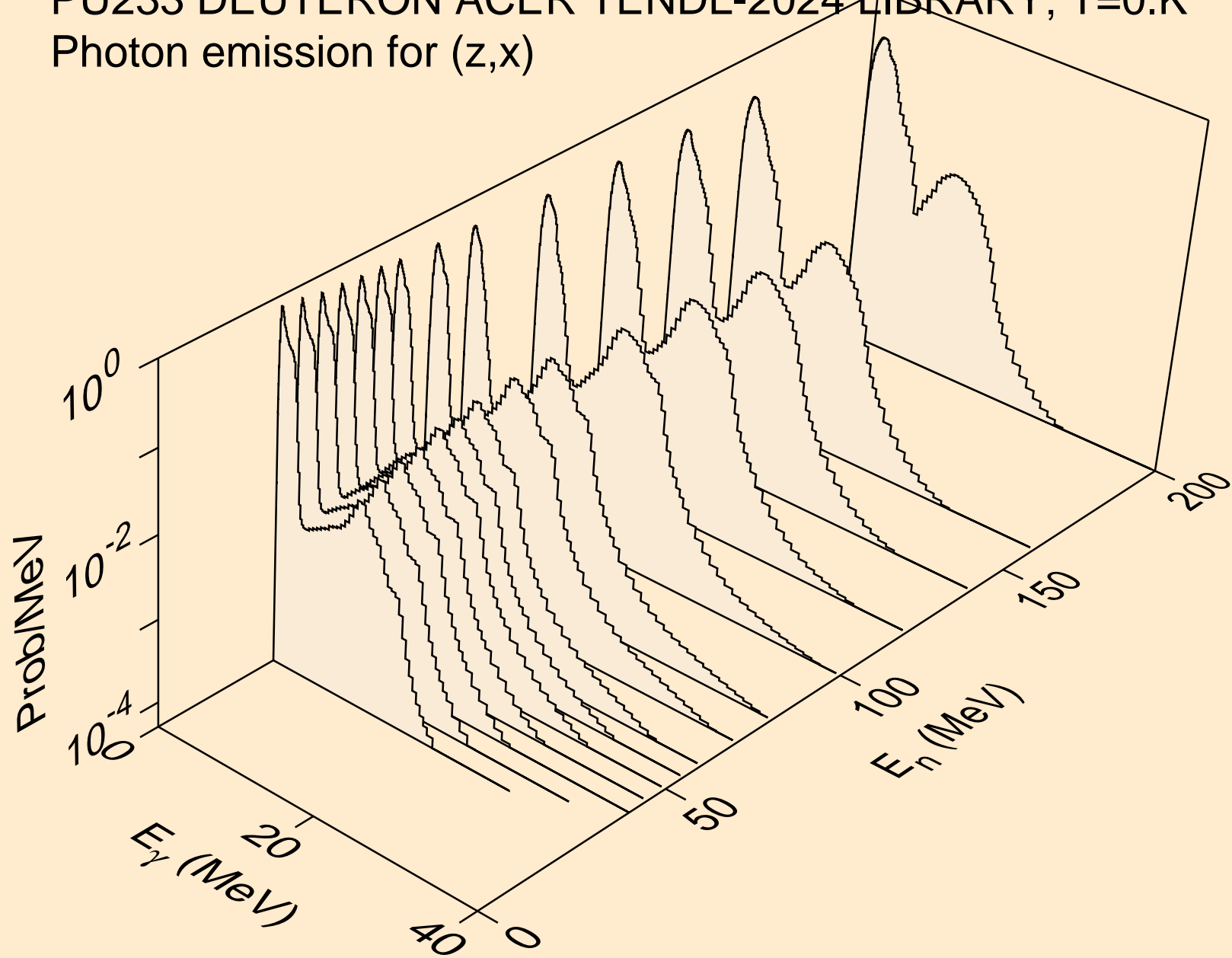

PU233 DEUTERON ACER TENDL-2024 LIBRARY; T=0.K
Photon emission for (n,2nd)

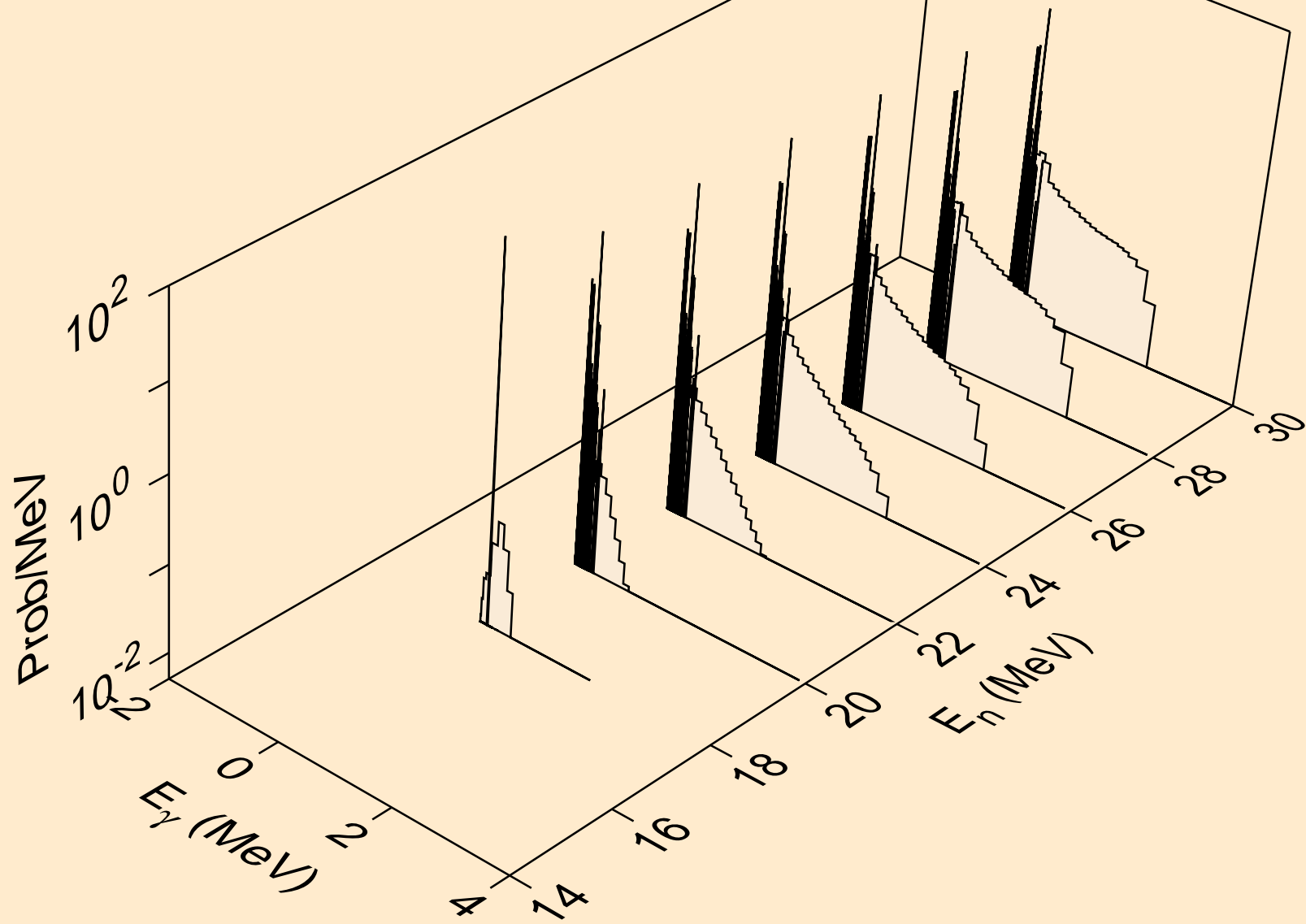

PU233 DEUTERON ACER TENDL-2024 LIBRARY; T=0.K
Photon emission for (n,2n)

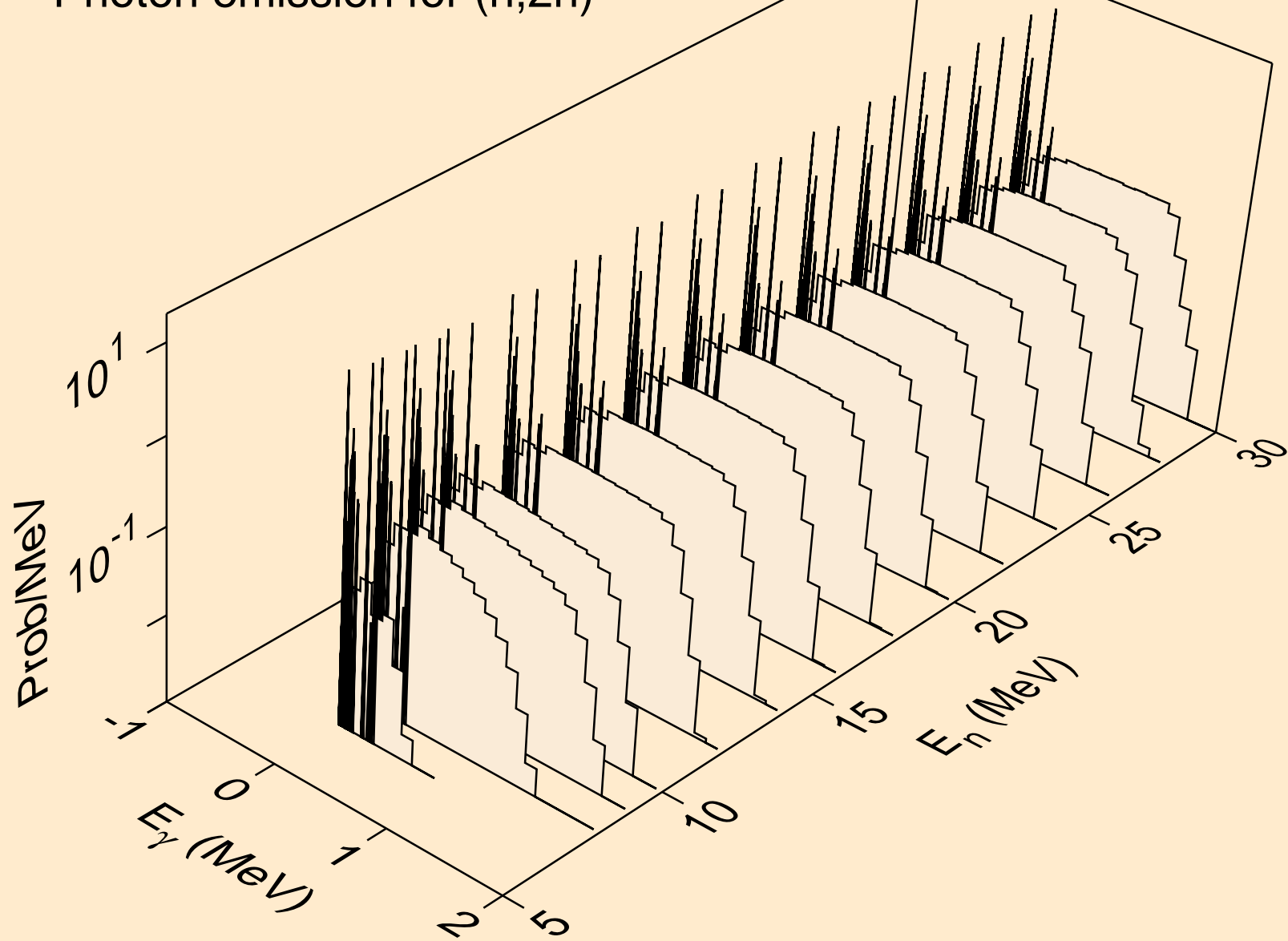

PU233 DEUTERON ACER TENDL-2024 LIBRARY; T=0.K
Photon emission for (n,3n)

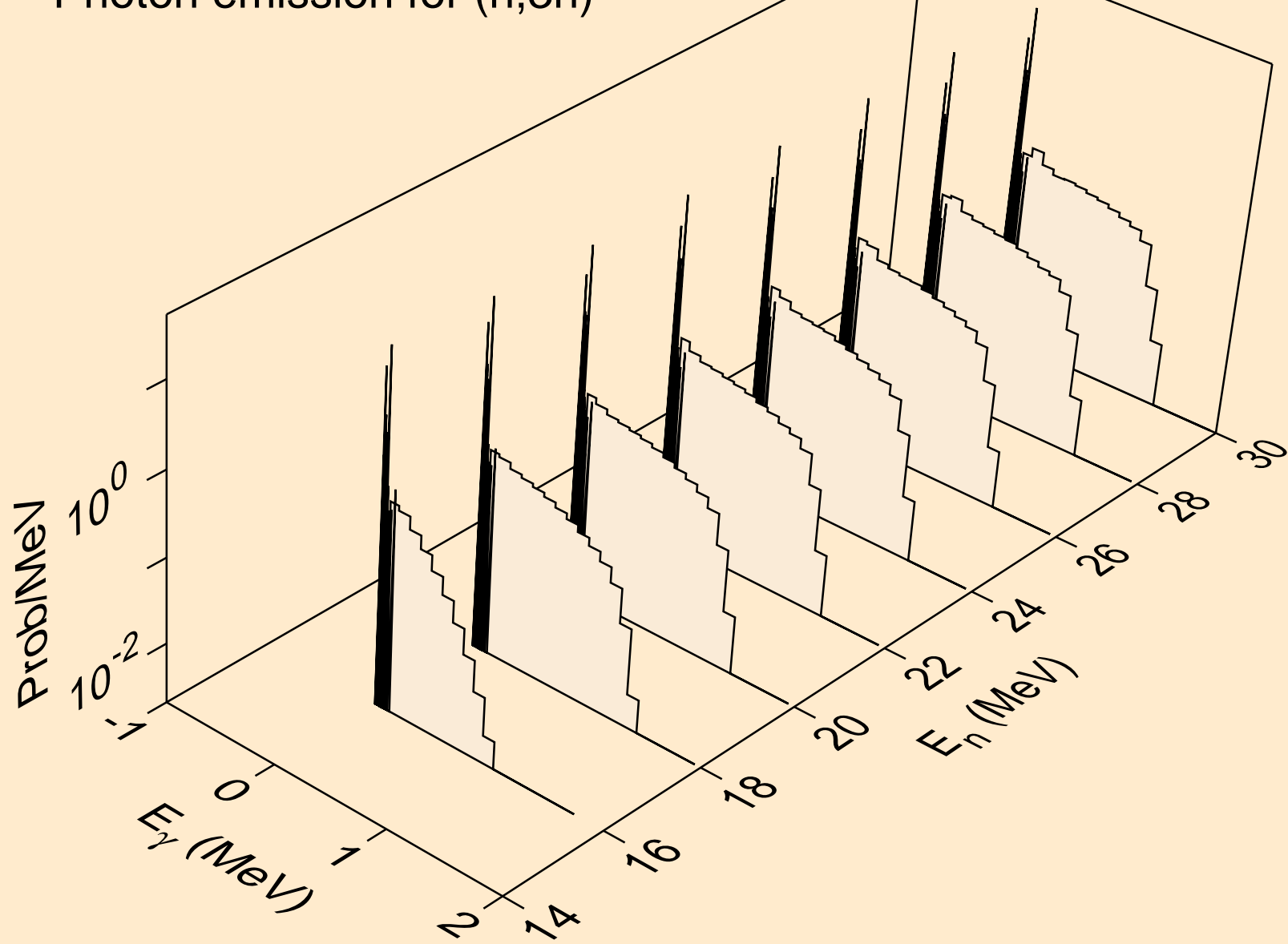

PU233 DEUTERON ACER TENDL-2024 LIBRARY; T=0.K
Photon emission for (n,n*)a

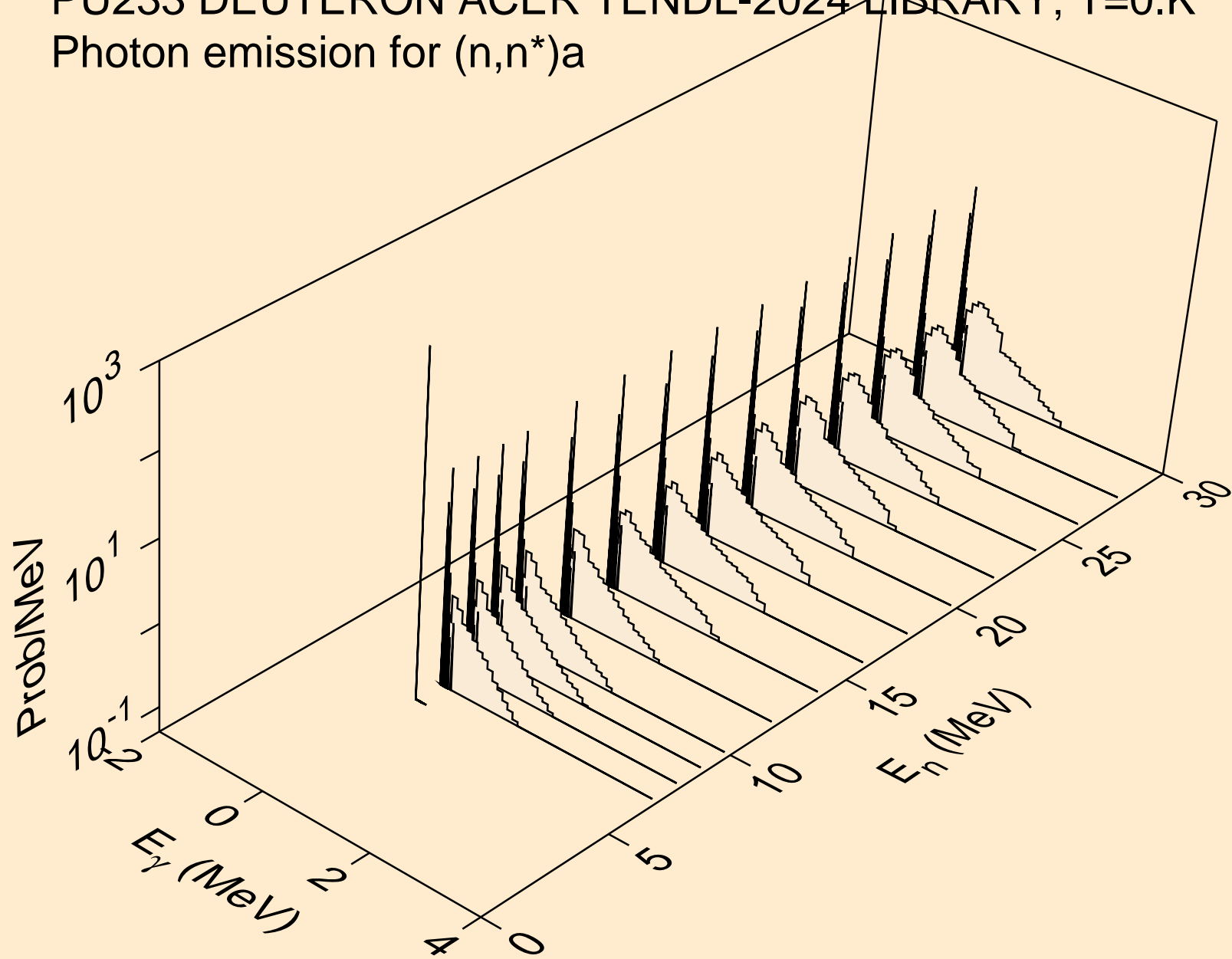

PU233 DEUTERON ACER TENDL-2024 LIBRARY; T=0.K
Photon emission for (n,2n)a

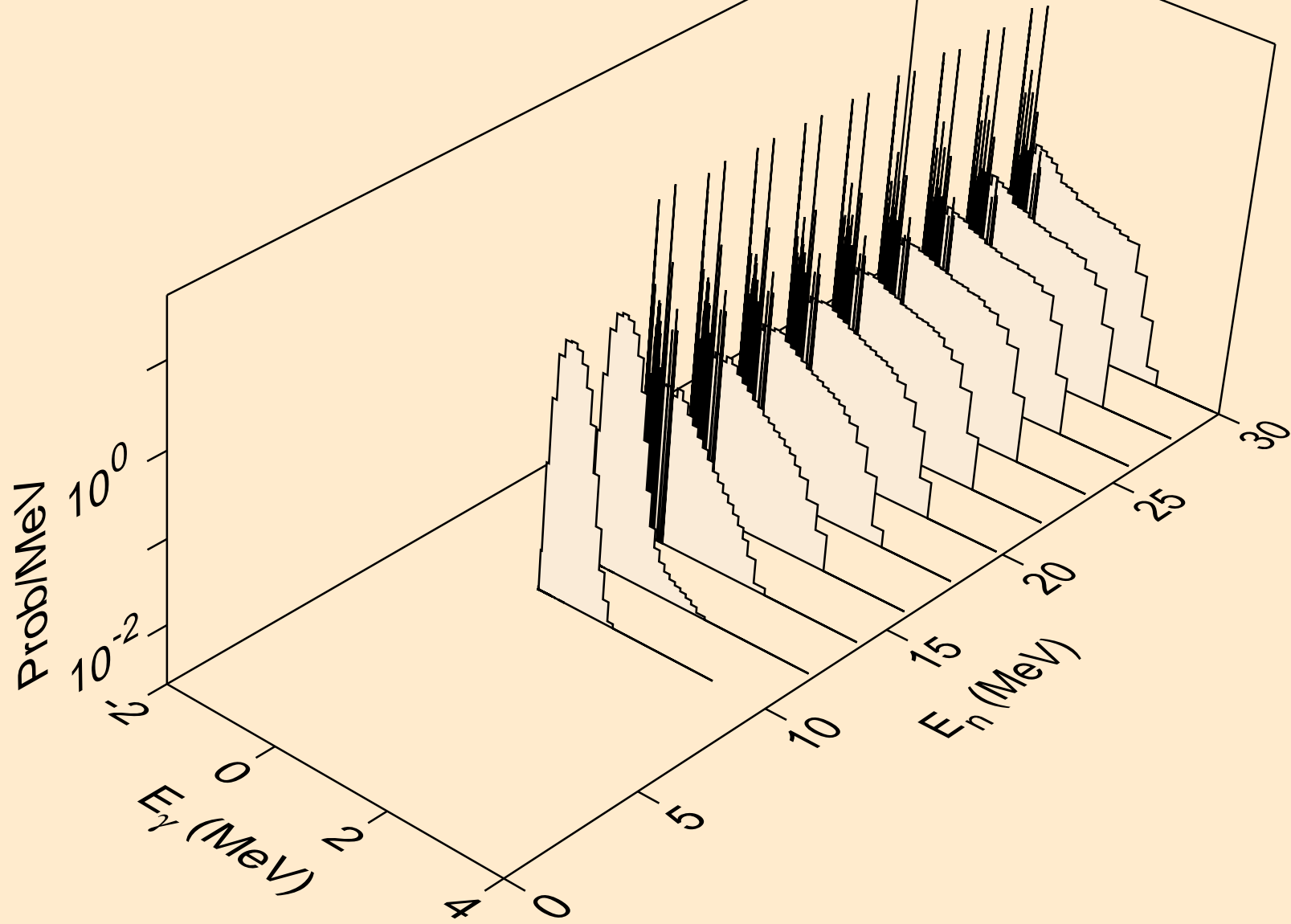

PU233 DEUTERON ACER TENDL-2024 LIBRARY; T=0.K
Photon emission for (n,3n)a

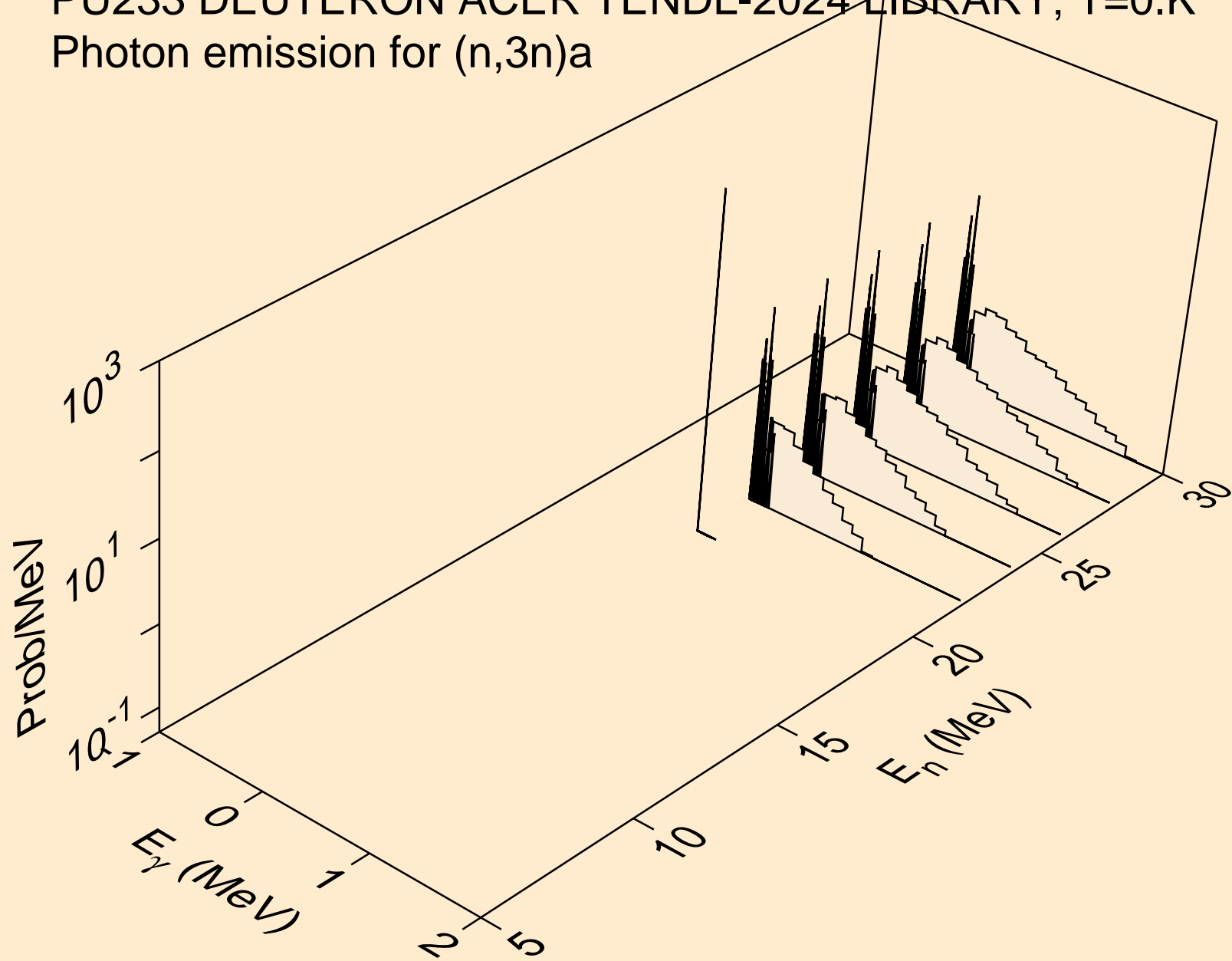

PU233 DEUTERON ACER TENDL-2024 LIBRARY; T=0.K
Photon emission for (n,n*)p

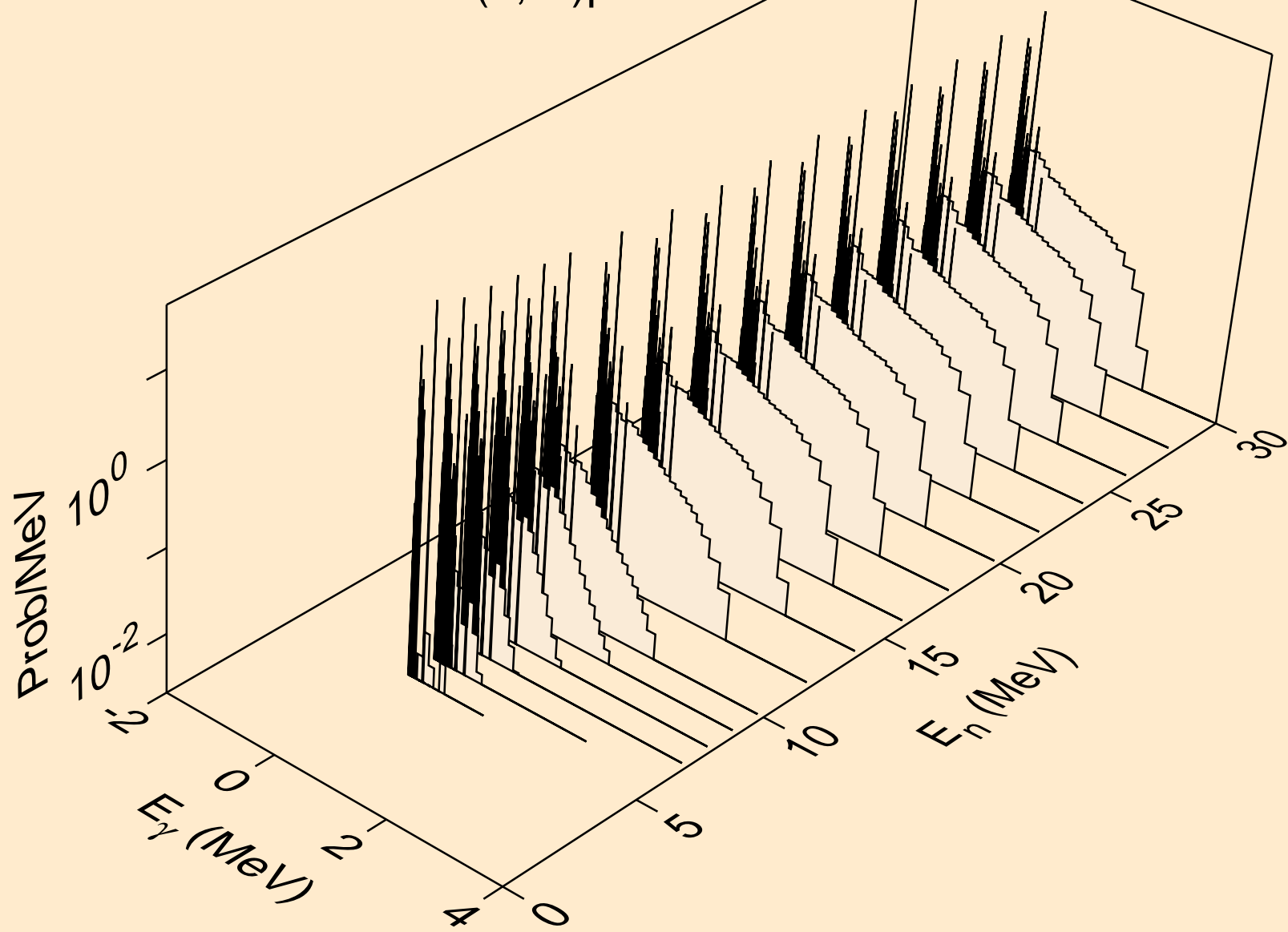

PU233 DEUTERON ACER TENDL-2024 LIBRARY; T=0.K
Photon emission for (n,n*)2a

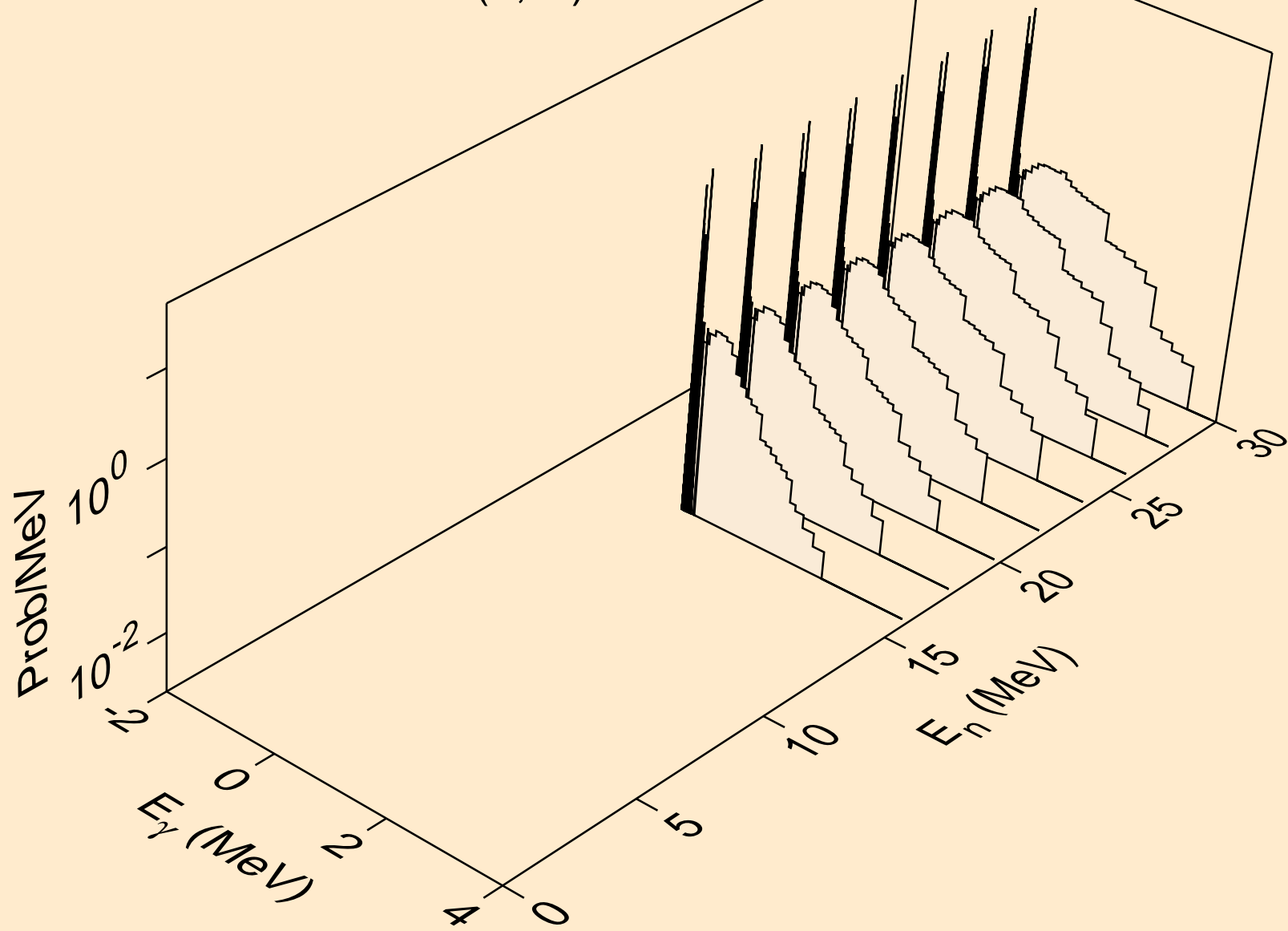

PU233 DEUTERON ACER TENDL-2024 LIBRARY; T=0.K
Photon emission for (n,n*)d

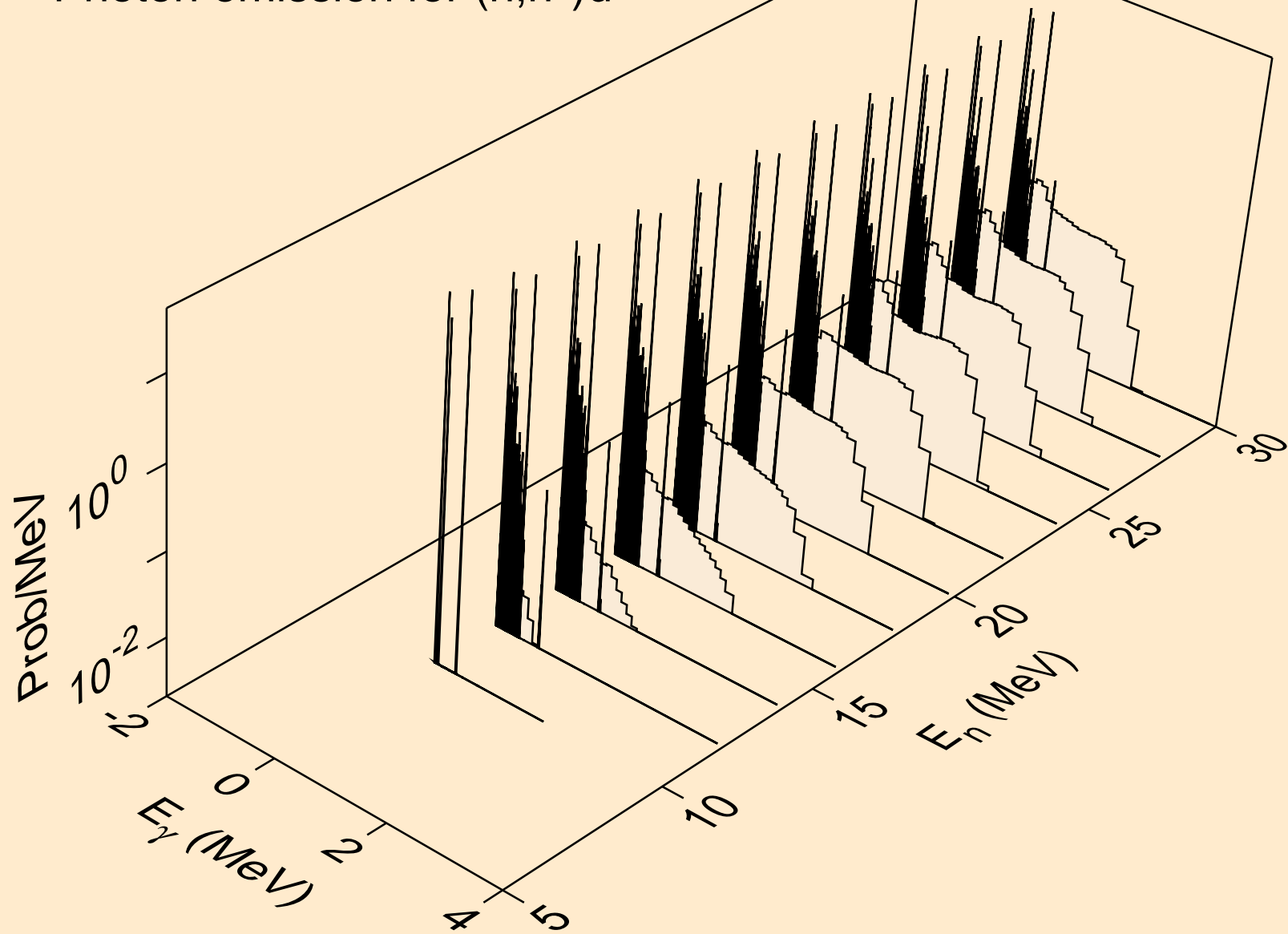

PU233 DEUTERON ACER TENDL-2024 LIBRARY; T=0.K
Photon emission for (n,n*)t

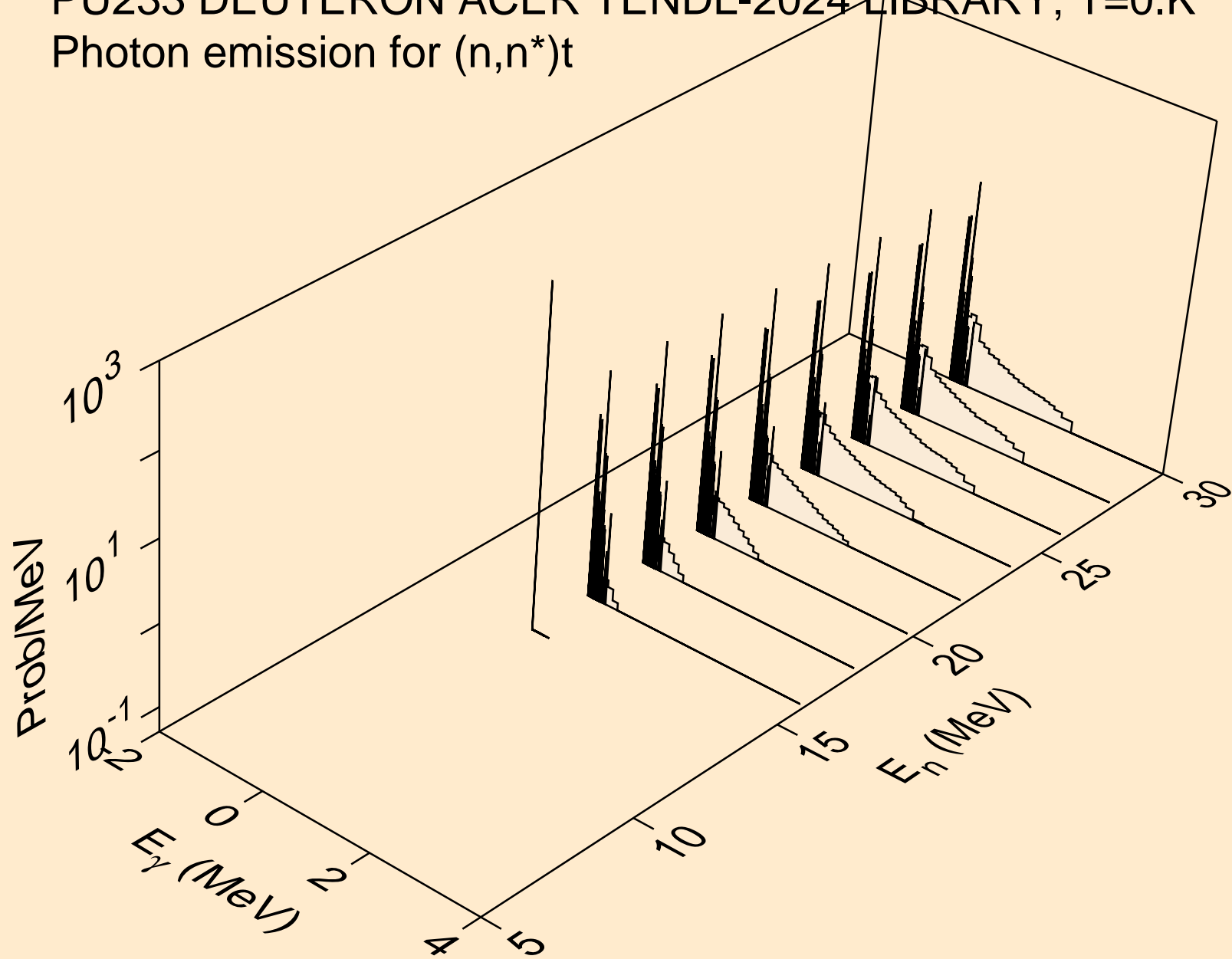

PU233 DEUTERON ACER TENDL-2024 LIBRARY; T=0.K
Photon emission for (n,n*)he3

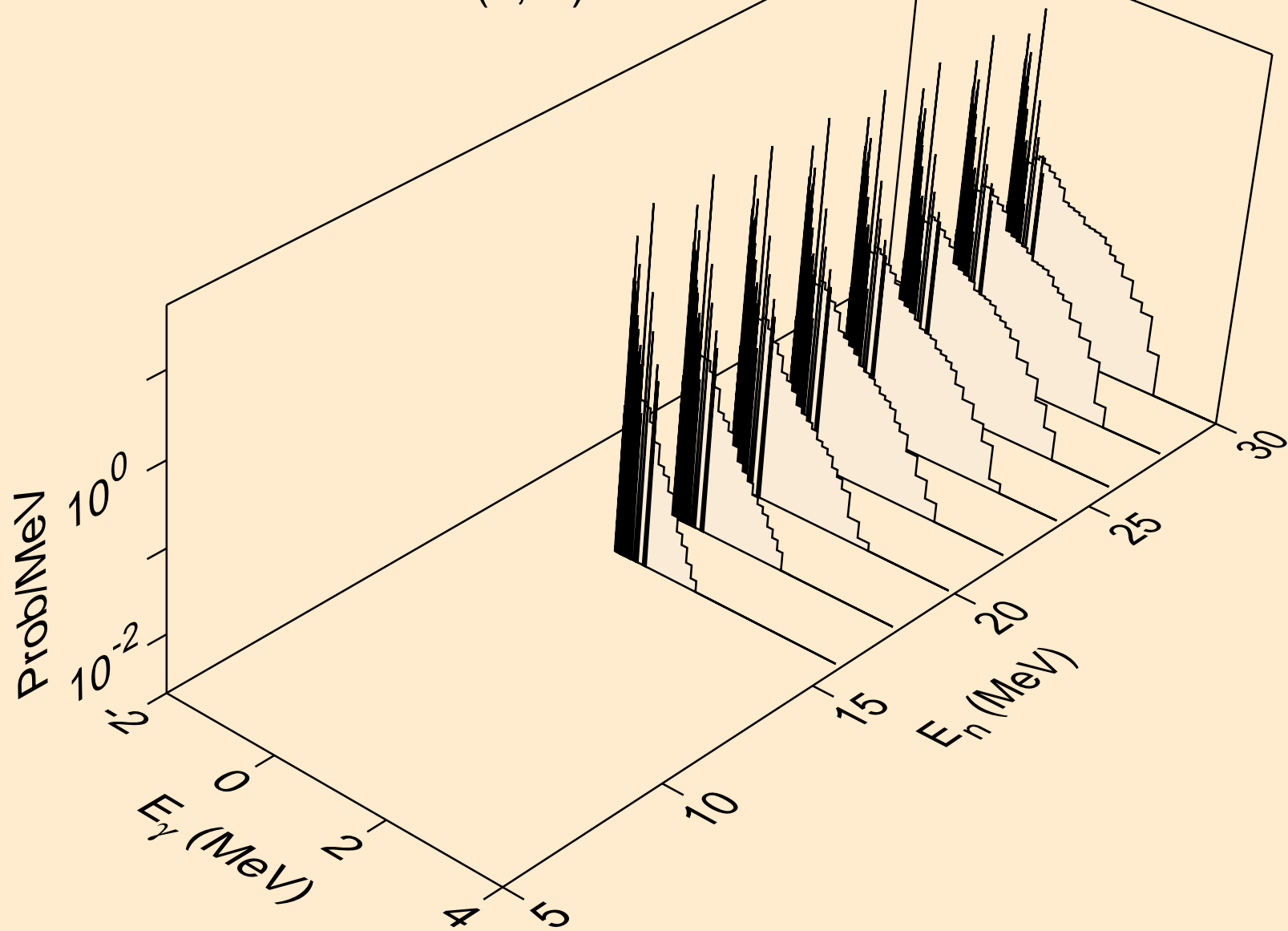

PU233 DEUTERON ACER TENDL-2024 LIBRARY; T=0.K
Photon emission for (n,4n)

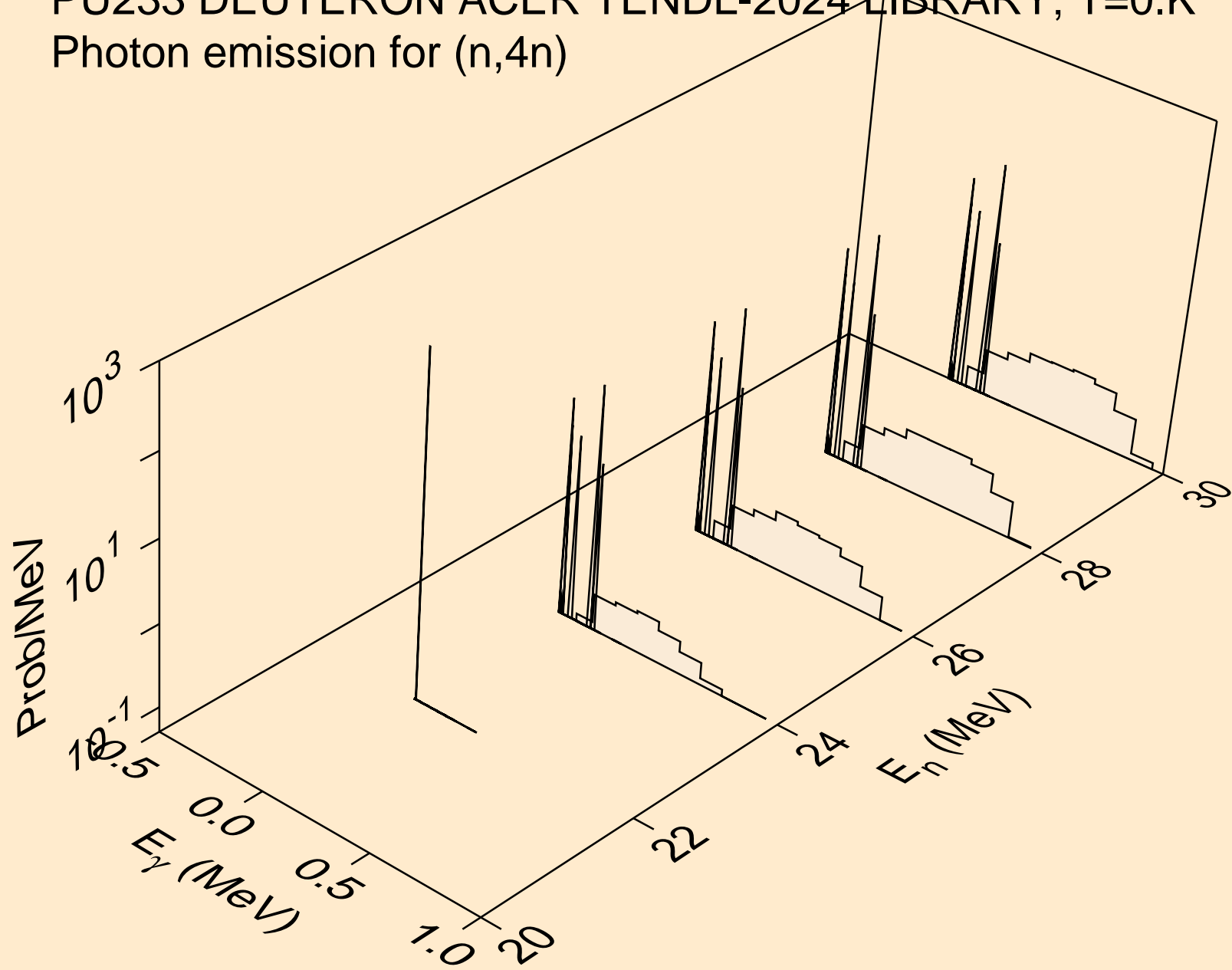

PU233 DEUTERON ACER TENDL-2024 LIBRARY; T=0.K
Photon emission for (n,2np)

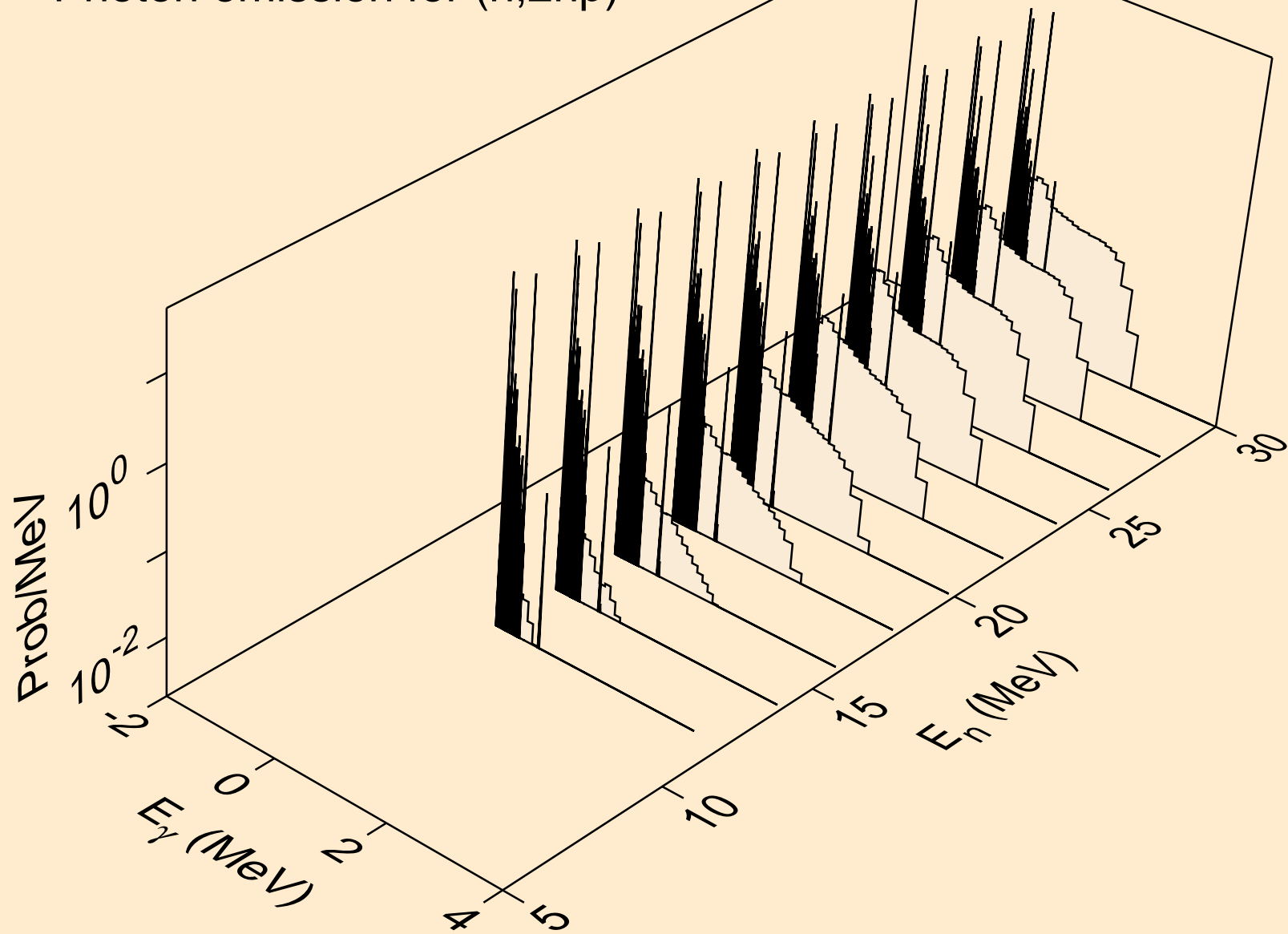

PU233 DEUTERON ACER TENDL-2024 LIBRARY; T=0.K
Photon emission for (n,3np)

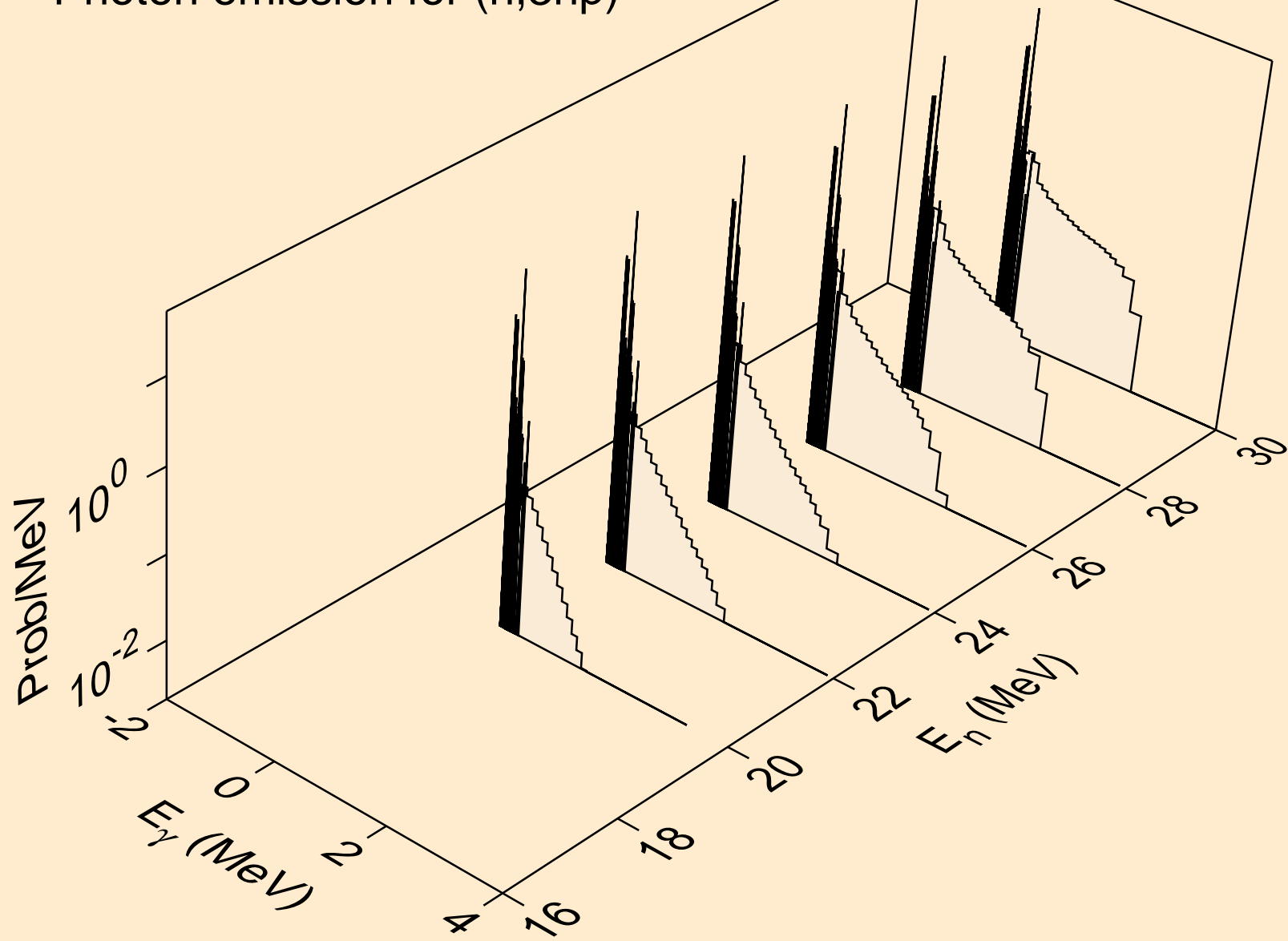

PU233 DEUTERON ACER TENDL-2024 LIBRARY; T=0.K
Photon emission for (n,n2p)

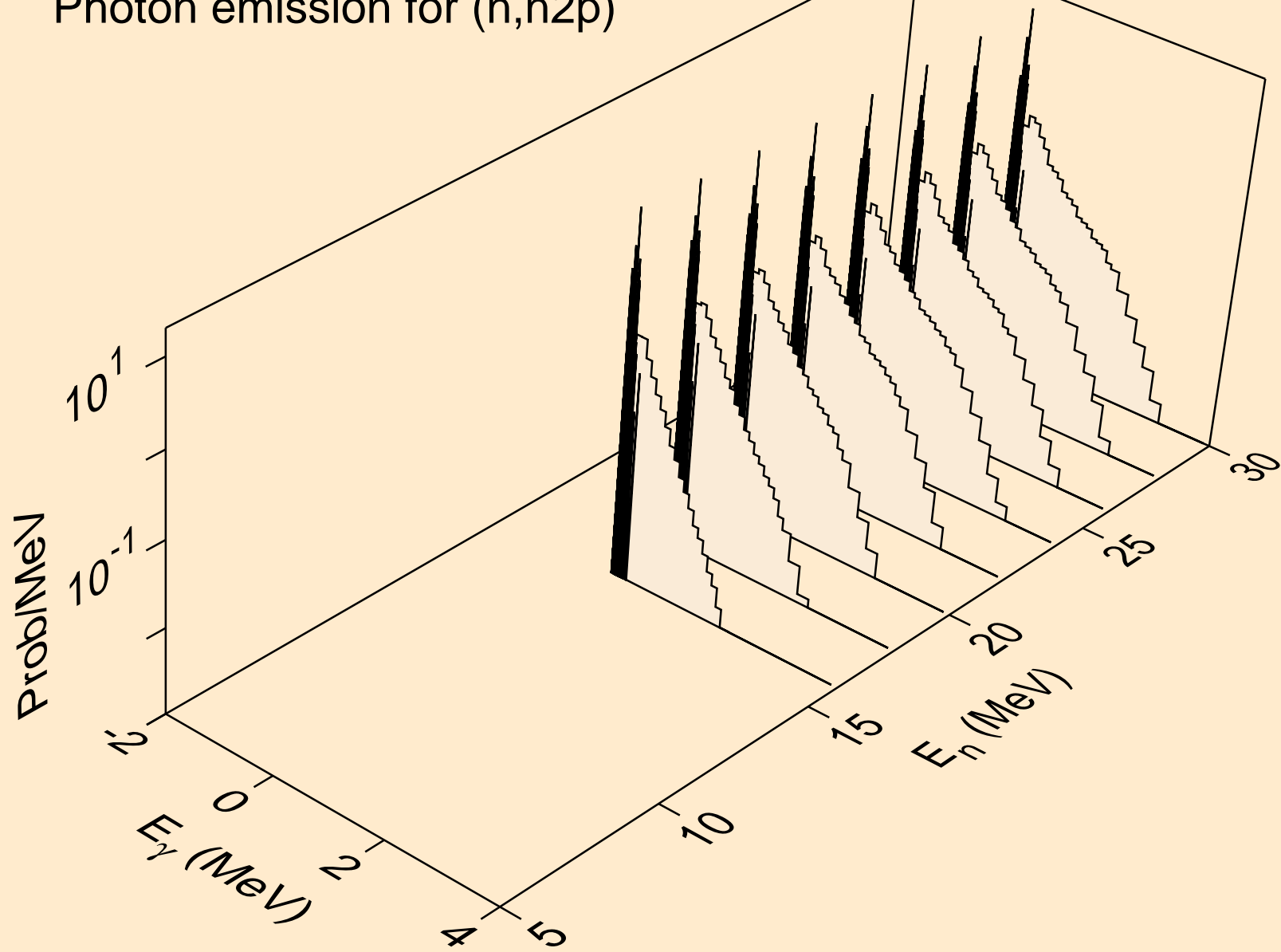

PU233 DEUTERON ACER TENDL-2024 LIBRARY; T=0.K
Photon emission for (n,npa)

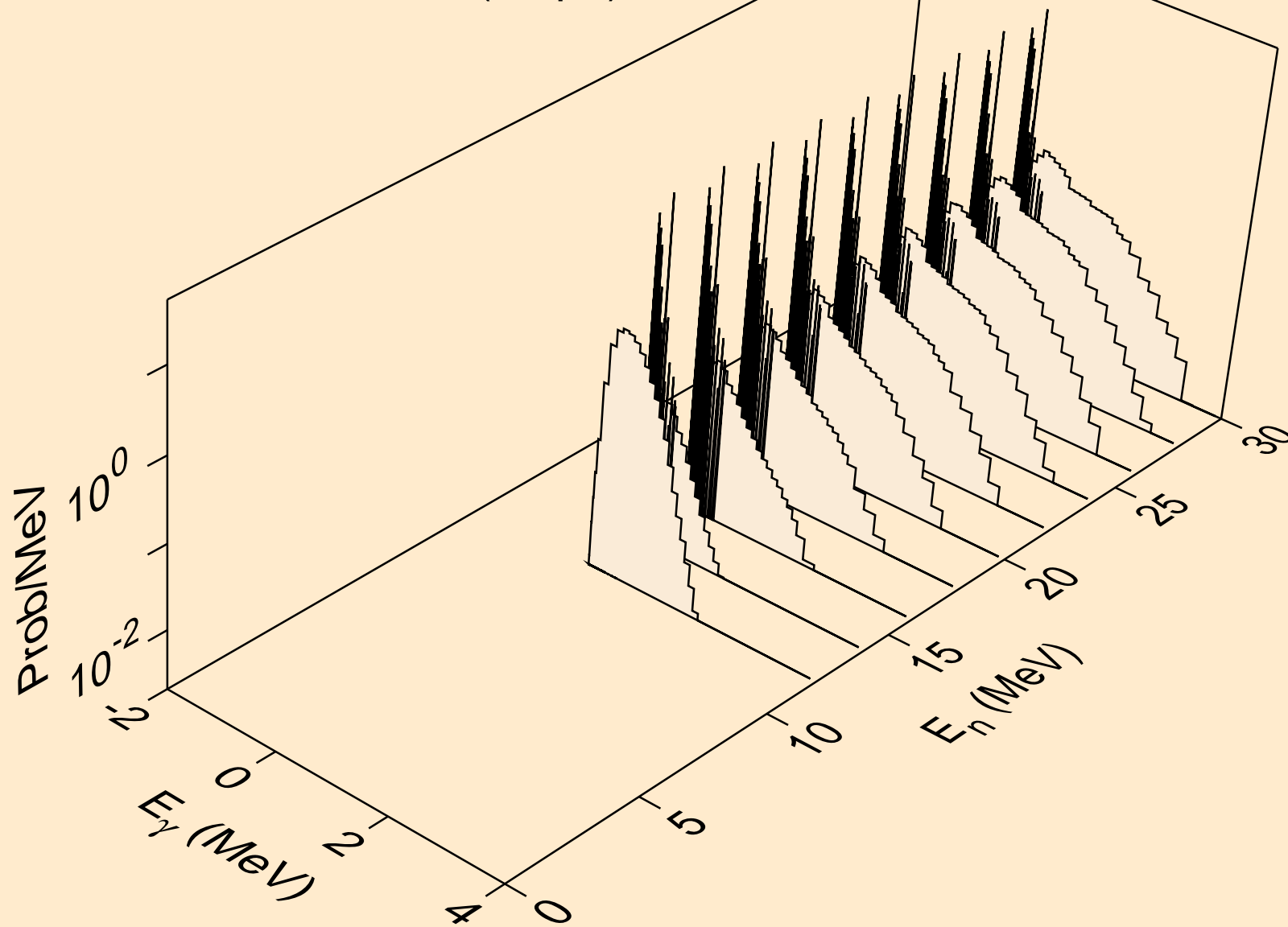

PU233 DEUTERON ACER TENDL-2024 LIBRARY; T=0.K
Photon emission for (n,p)

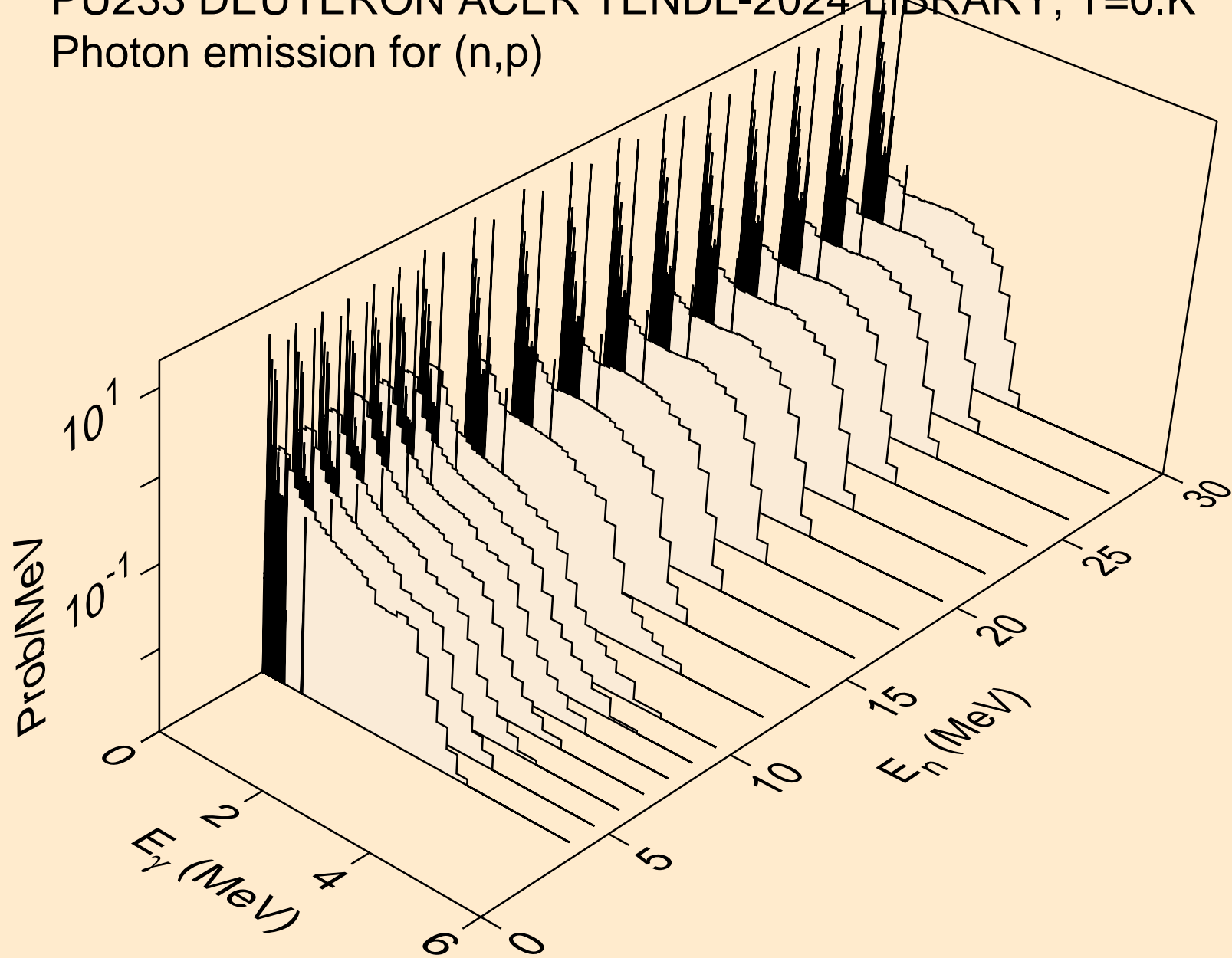

PU233 DEUTERON ACER TENDL-2024 LIBRARY; T=0.K
Photon emission for inelastic

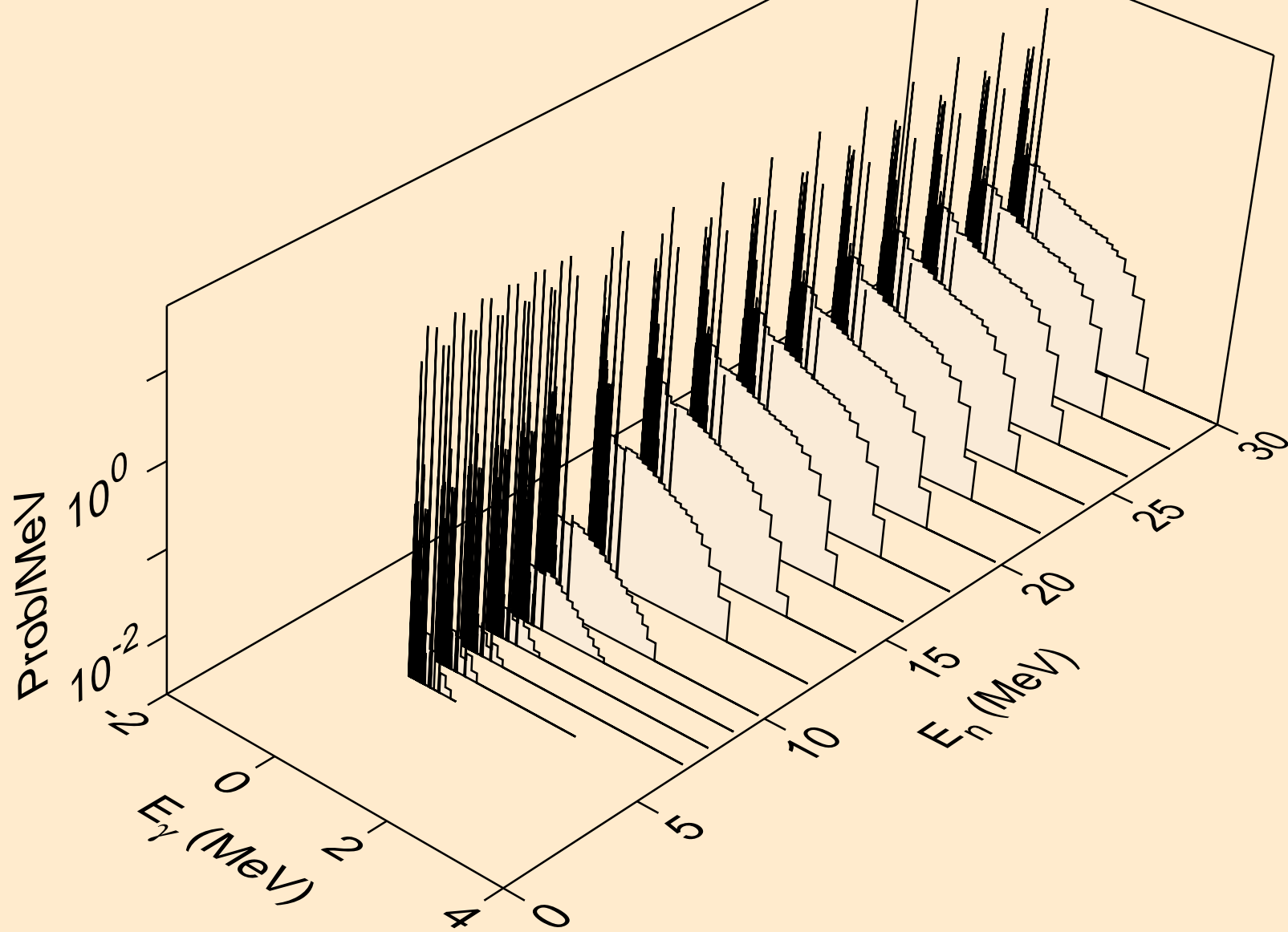

PU233 DEUTERON ACER TENDL-2024 LIBRARY; T=0.K
Photon emission for (n,t)

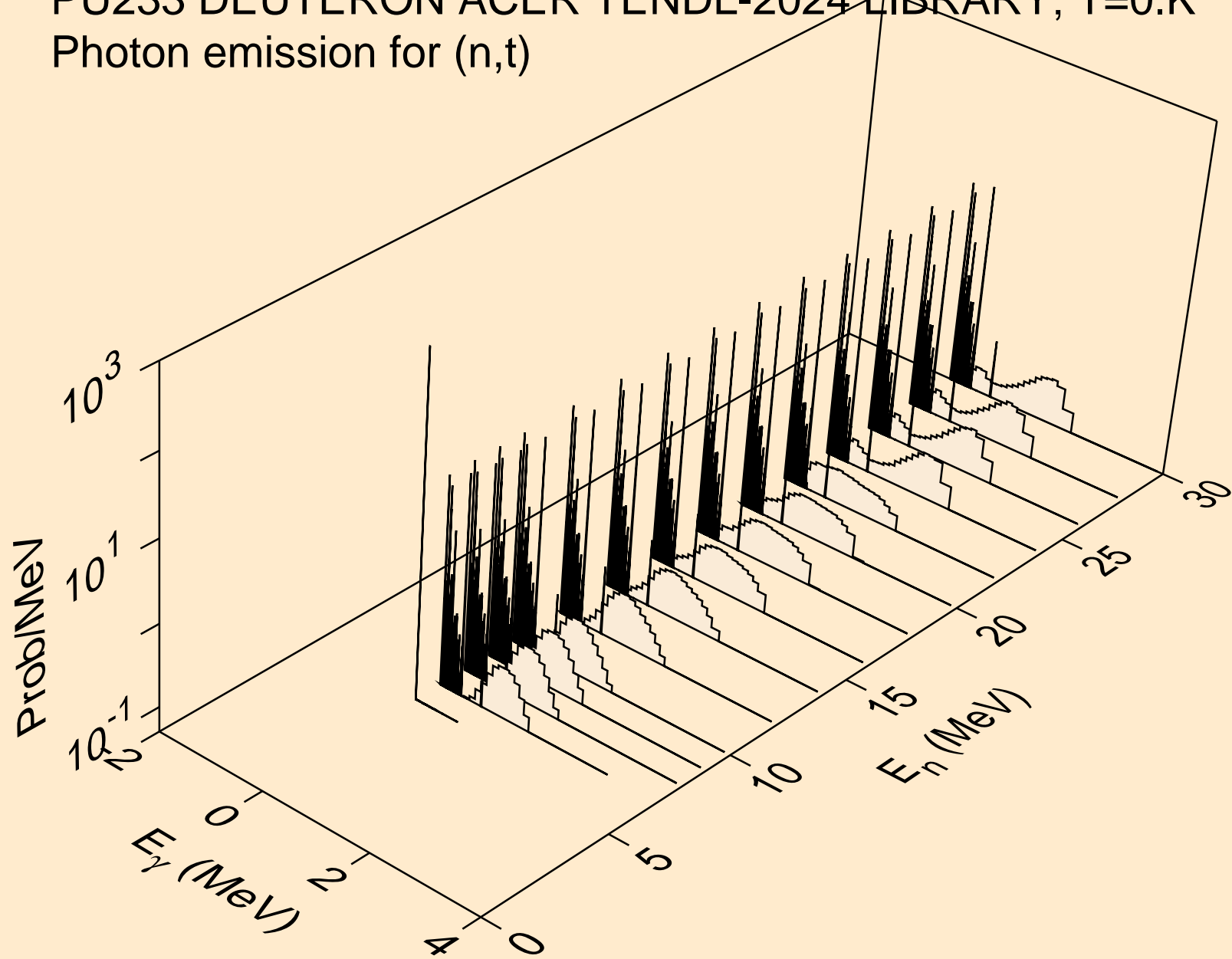

PU233 DEUTERON ACER TENDL-2024 LIBRARY; T=0.K
Photon emission for (n,he3)

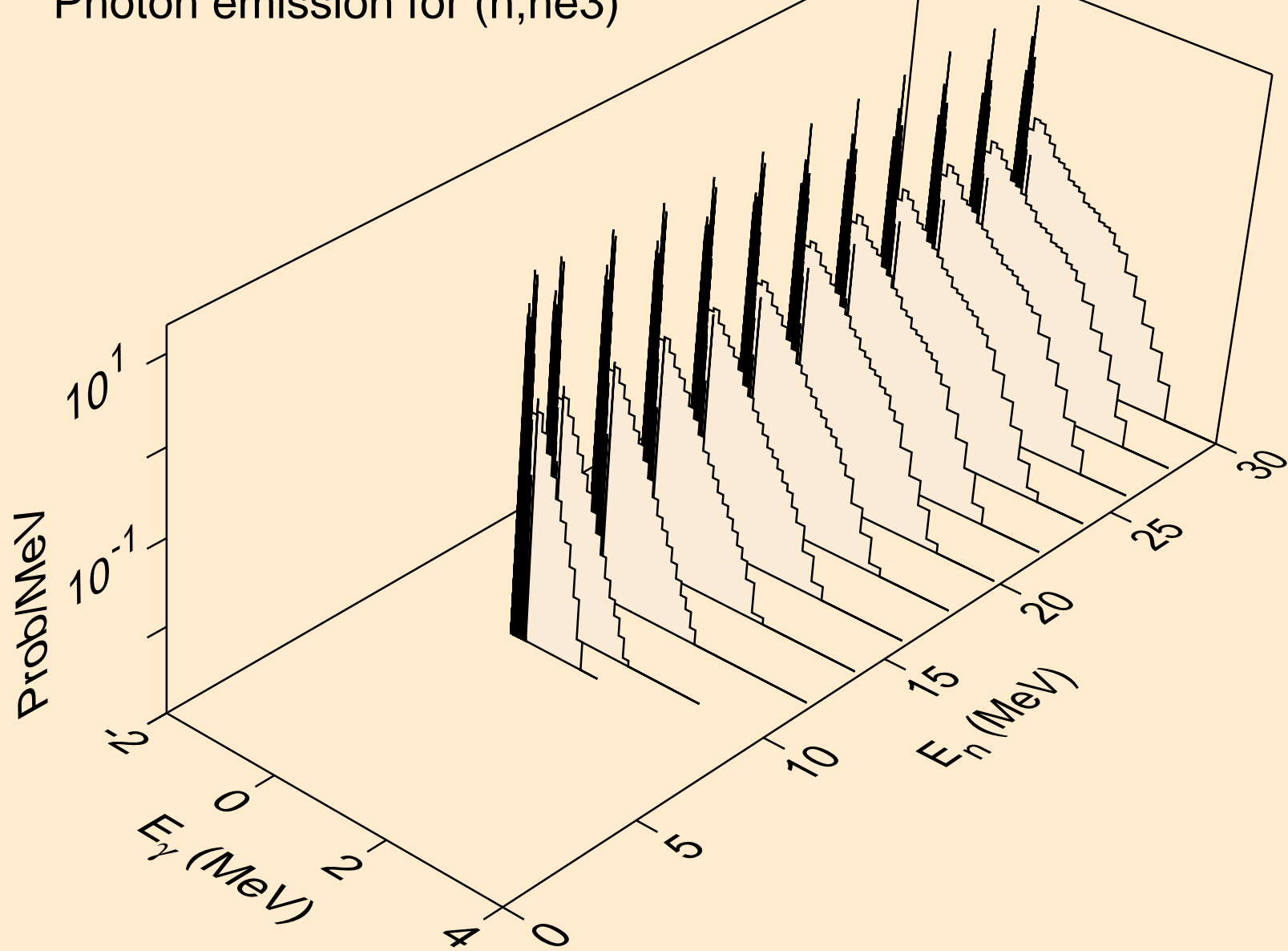

PU233 DEUTERON ACER TENDL-2024 LIBRARY; T=0.K
Photon emission for (n,a)

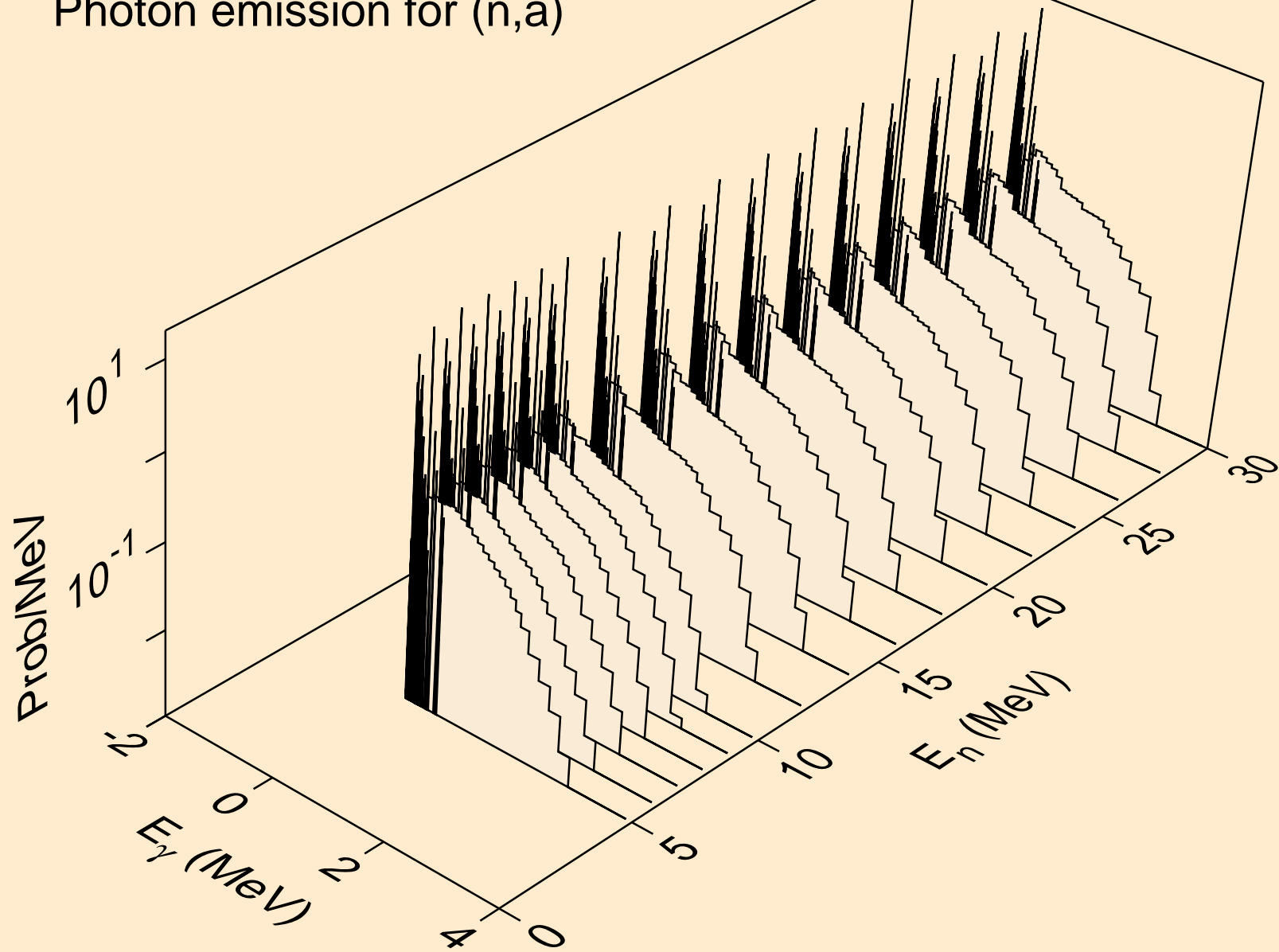

PU233 DEUTERON ACER TENDL-2024 LIBRARY; T=0.K
Photon emission for (n,2a)

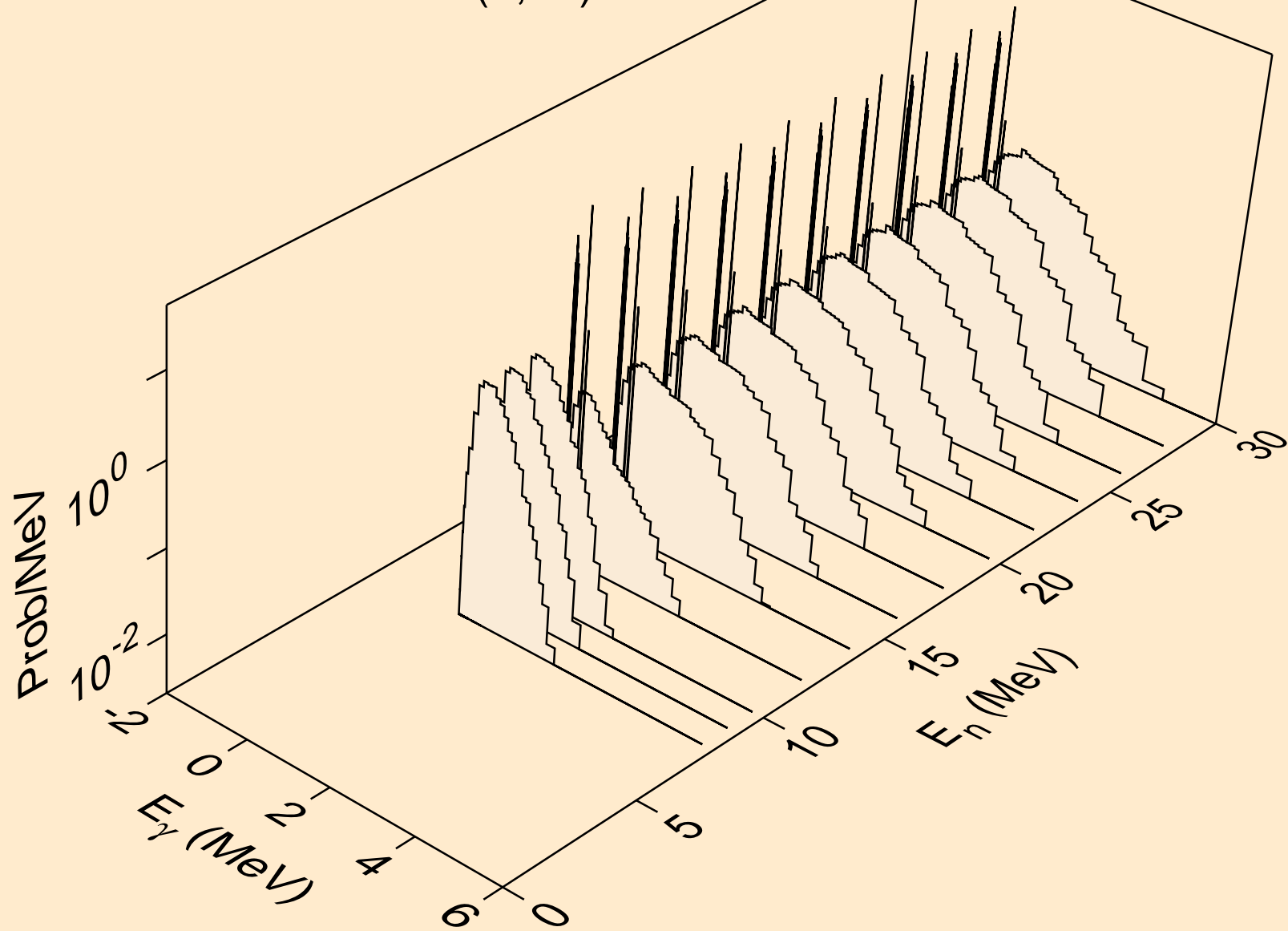

PU233 DEUTERON ACER TENDL-2024 LIBRARY; T=0.K
Photon emission for (n,2p)

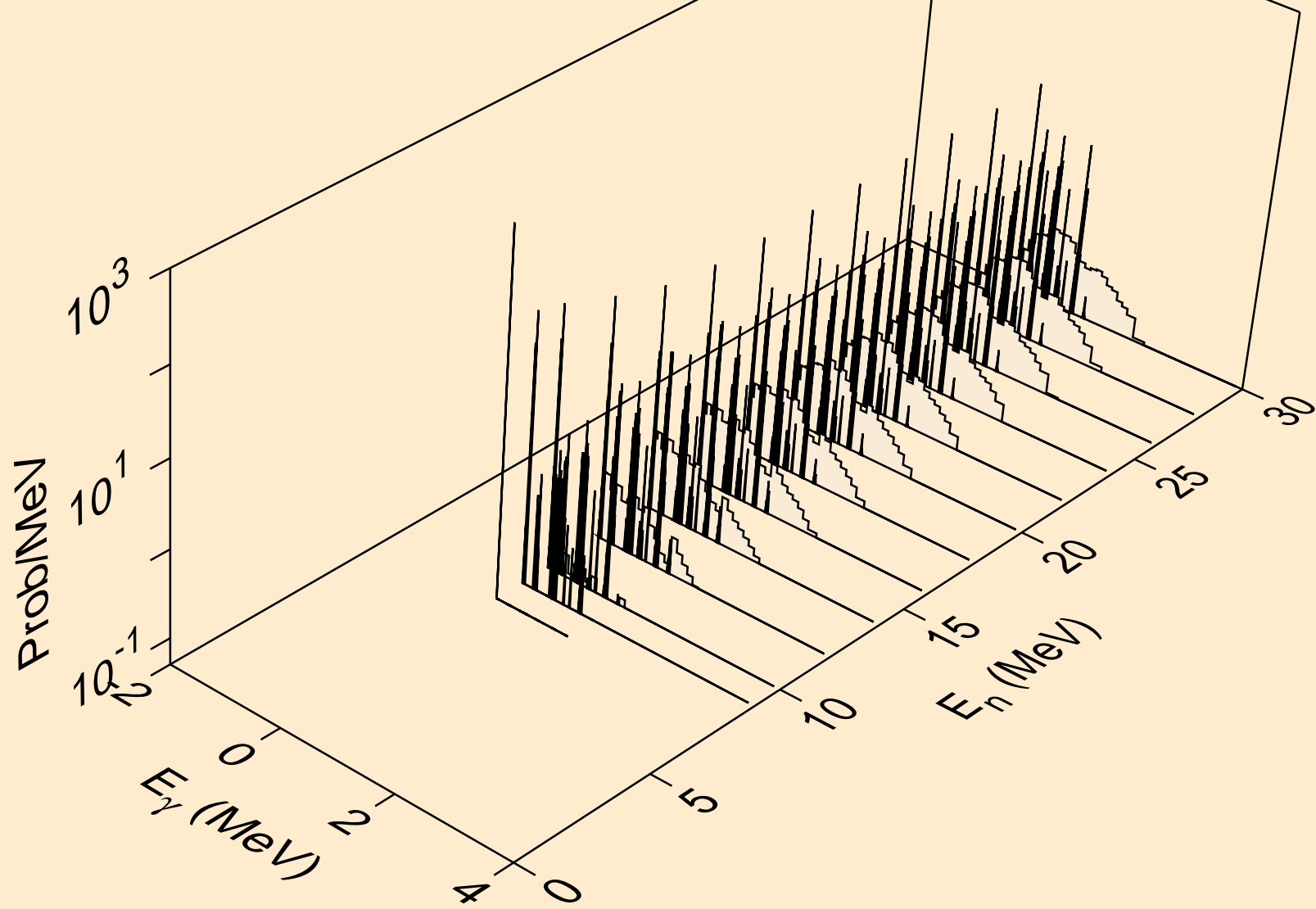

PU233 DEUTERON ACER TENDL-2024 LIBRARY; T=0.K
Photon emission for (n,pa)

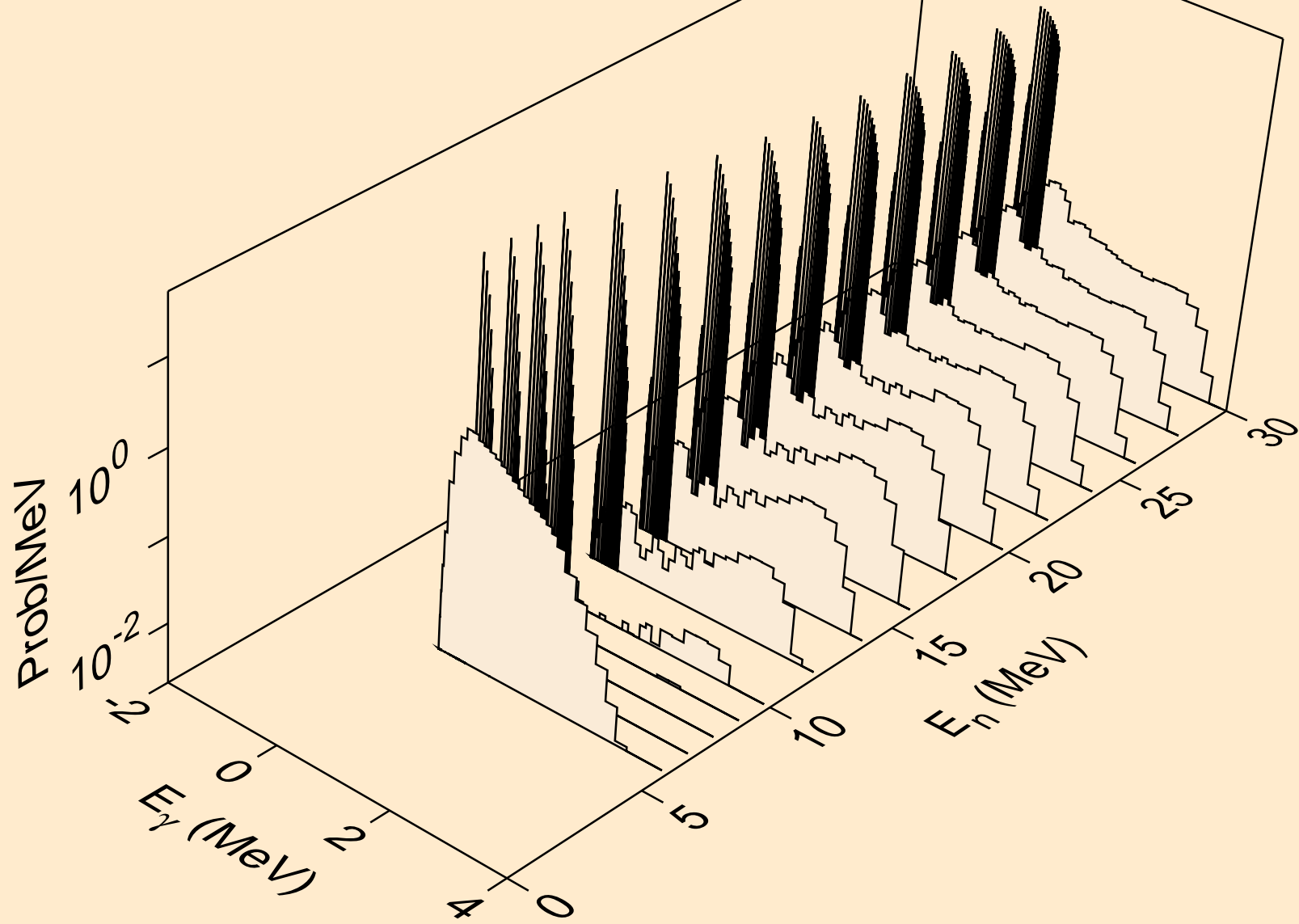

PU233 DEUTERON ACER TENDL-2024 LIBRARY; T=0.K
Photon emission for (n,pd)

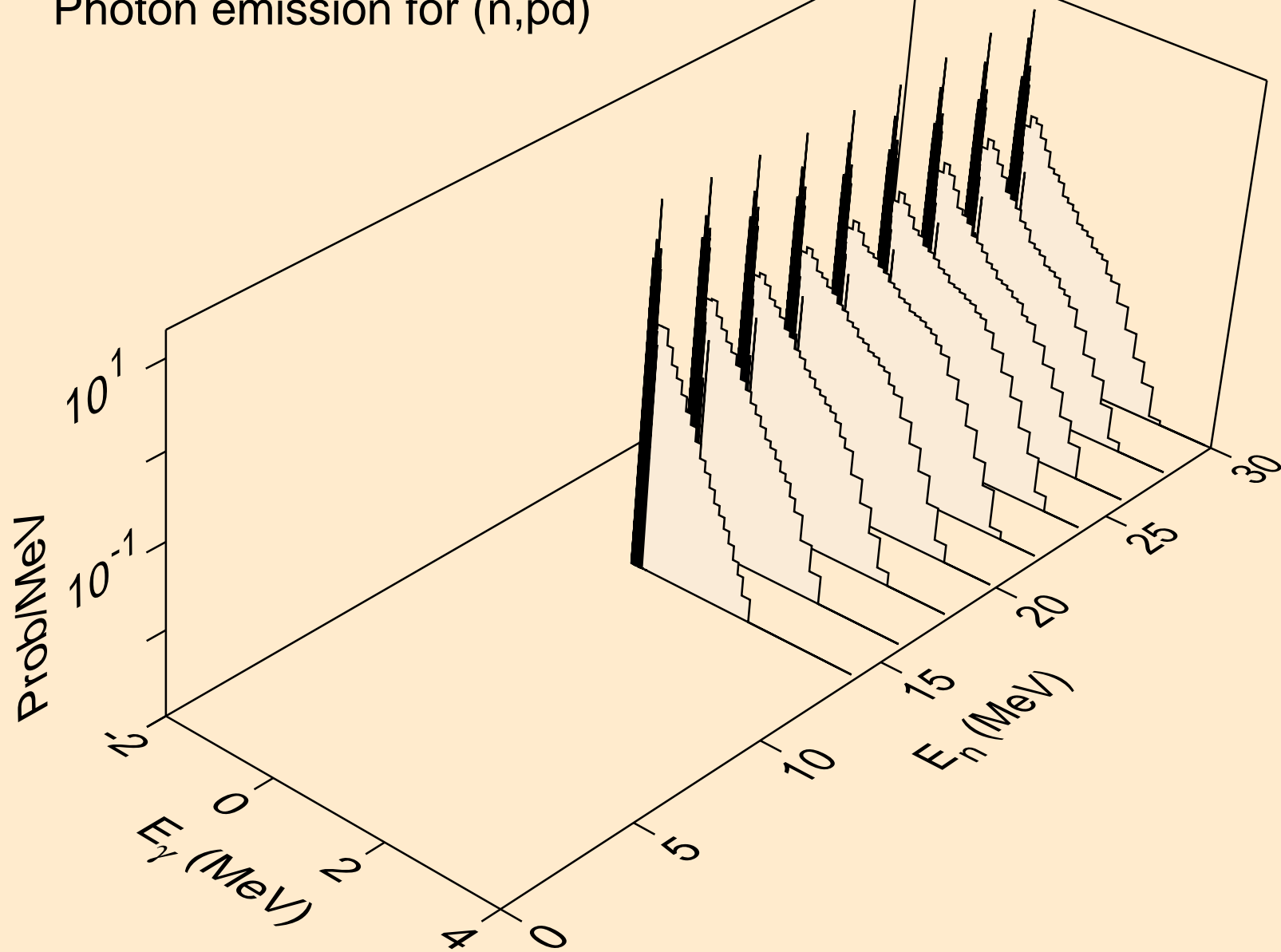

PU233 DEUTERON ACER TENDL-2024 LIBRARY; T=0.K
Photon emission for (n,da)

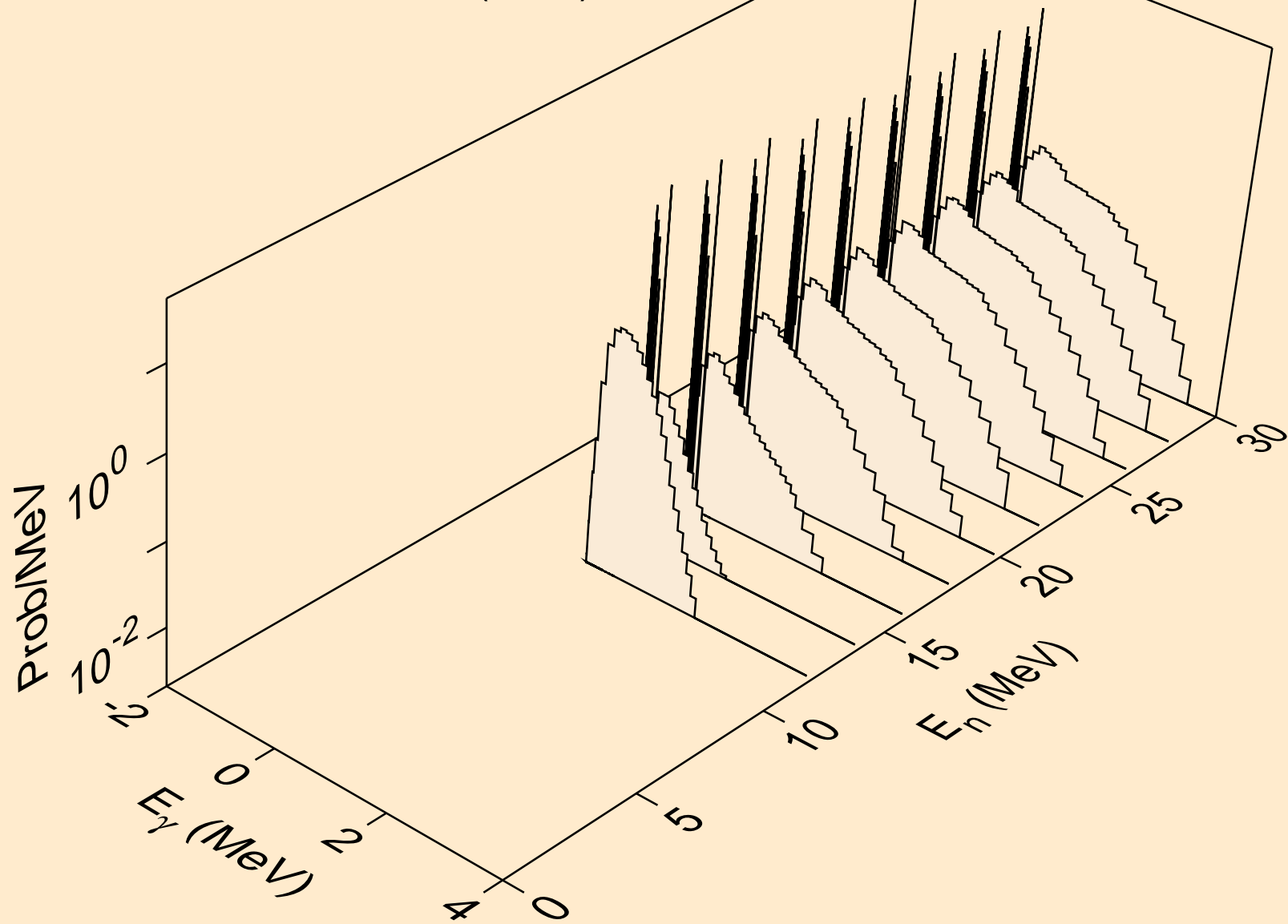

PU233 DEUTERON ACER TENDL-2024 LIBRARY; T=0.K

Particle heating contributions

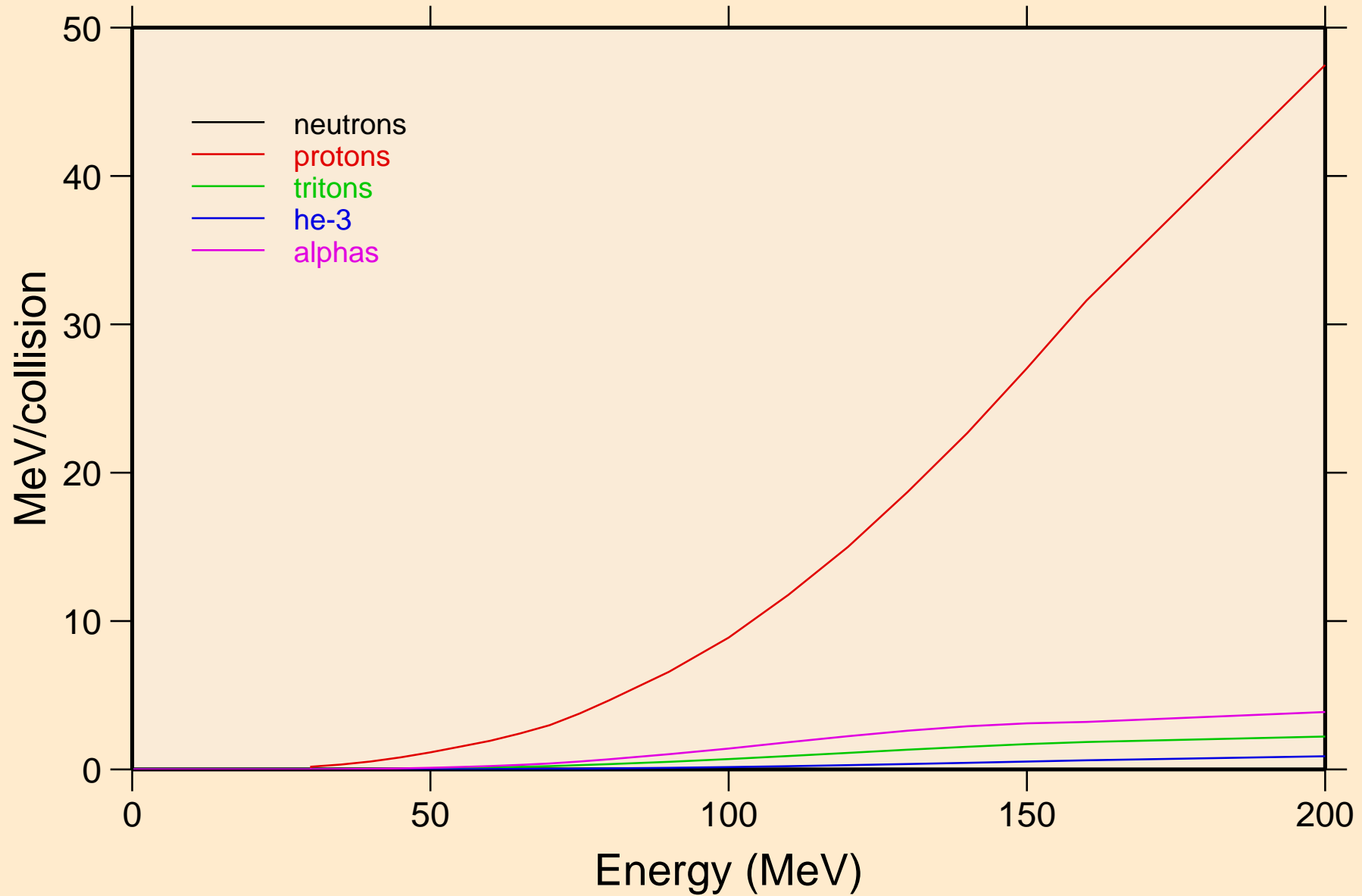

PU233 DEUTERON ACER TENDL-2024 LIBRARY; T=0.K
Recoil Heating

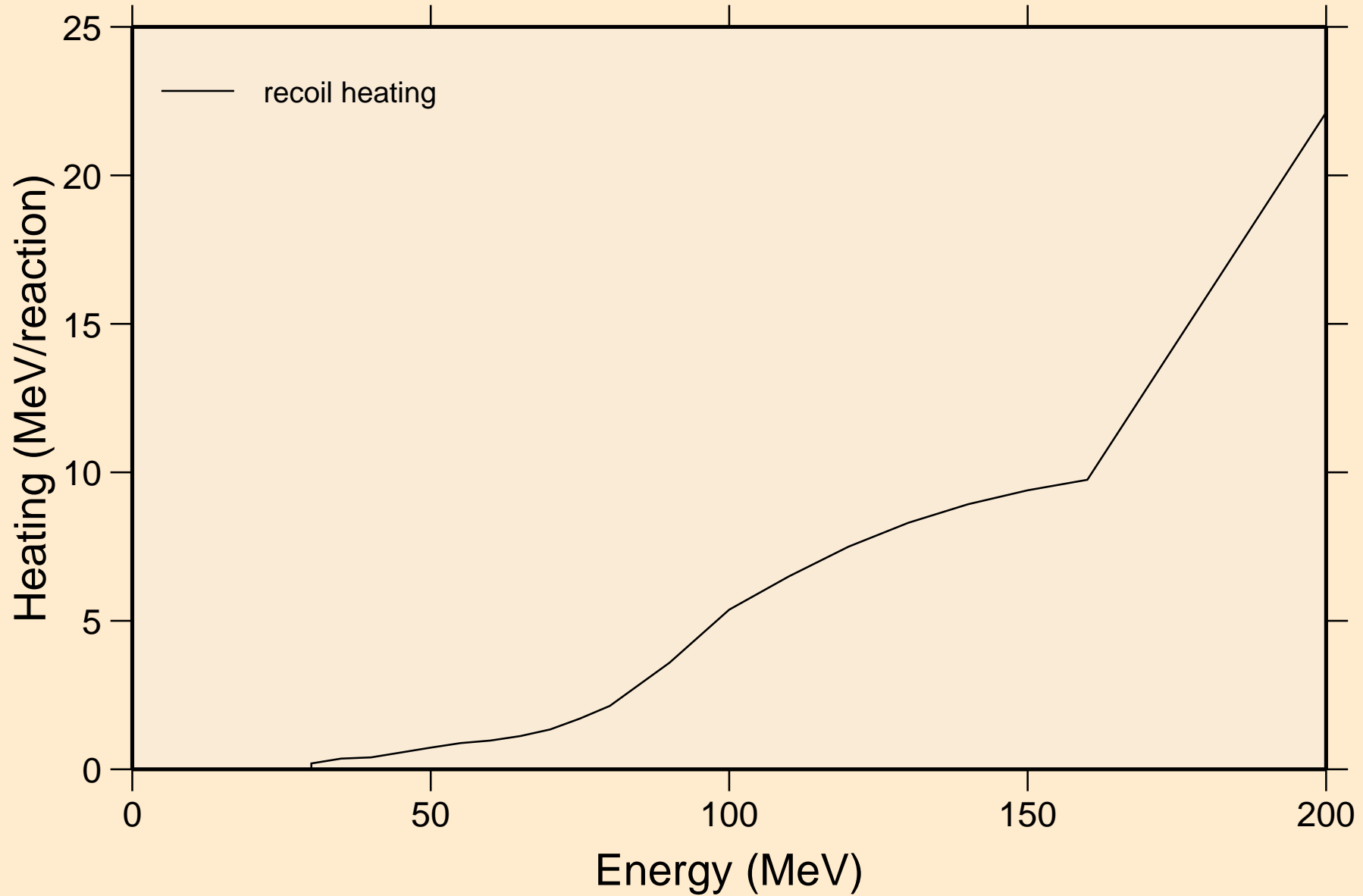

PU233 DEUTERON ACER TENDL-2024 LIBRARY; T=0.K
Particle production cross sections

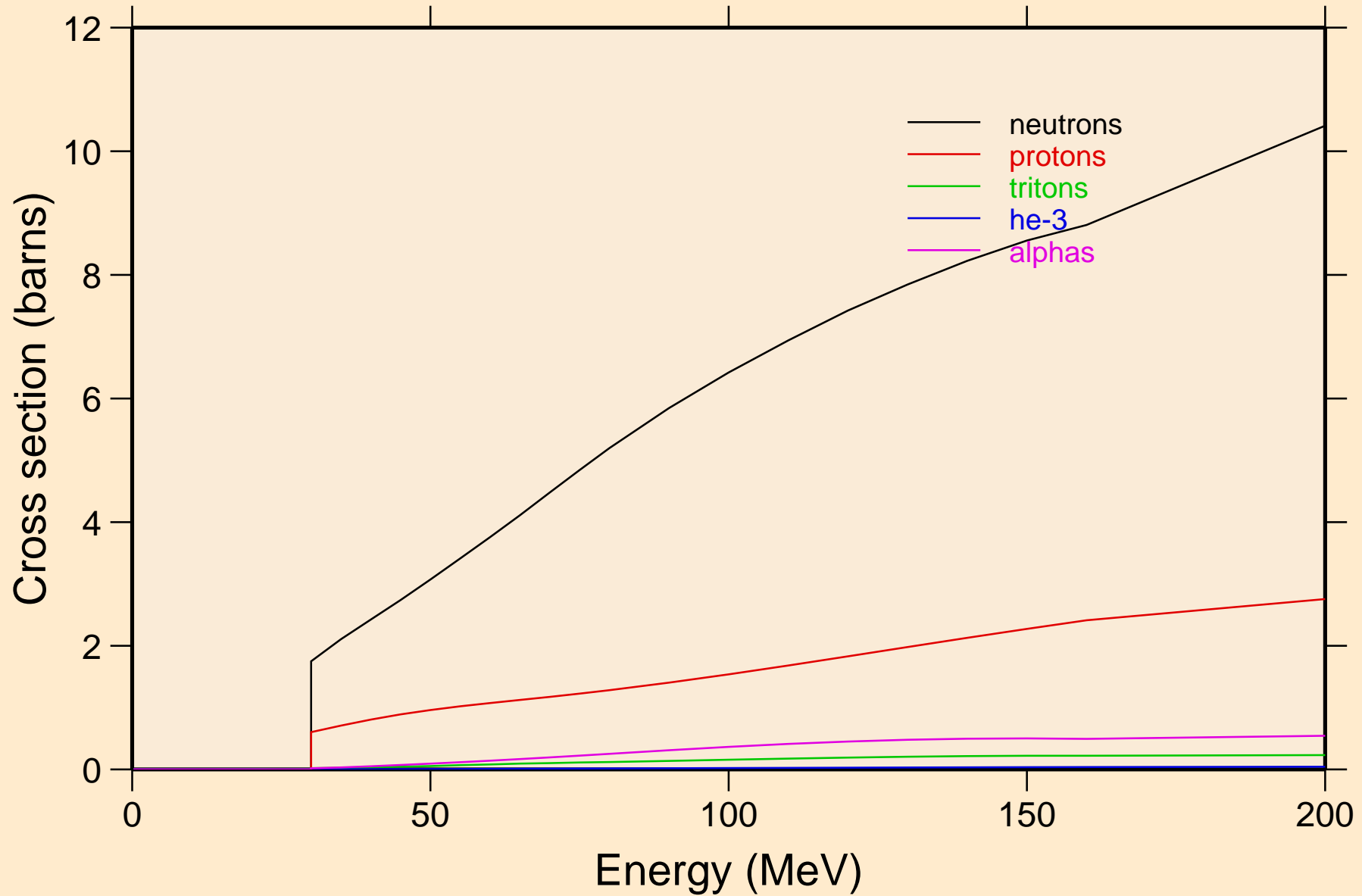

PU233 DEUTERON ACER TENDL-2024 LIBRARY; T=0.K
neutrons from (d,n)

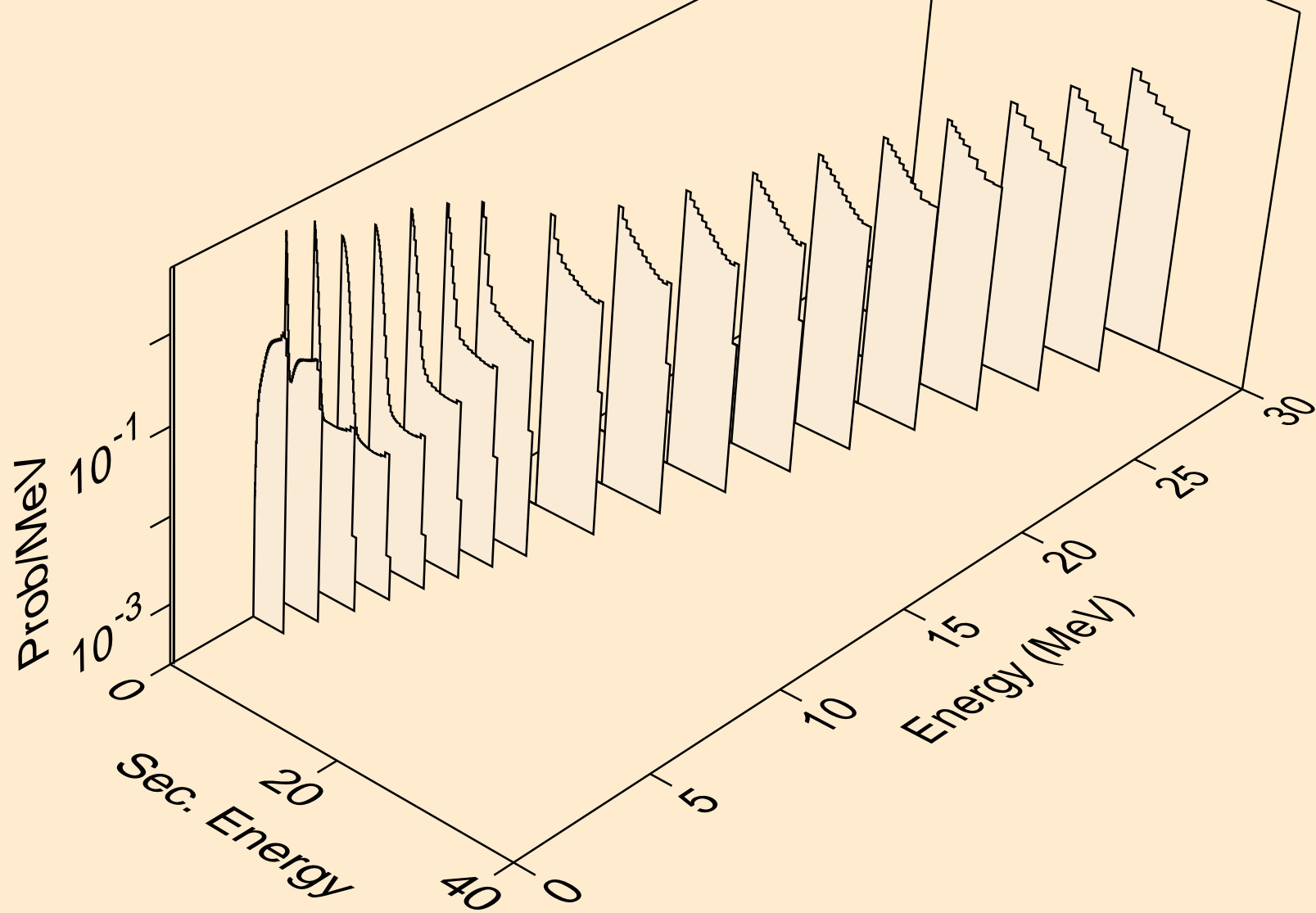

PU233 DEUTERON ACER TENDL-2024 LIBRARY; T=0.K
neutrons from (d,x)

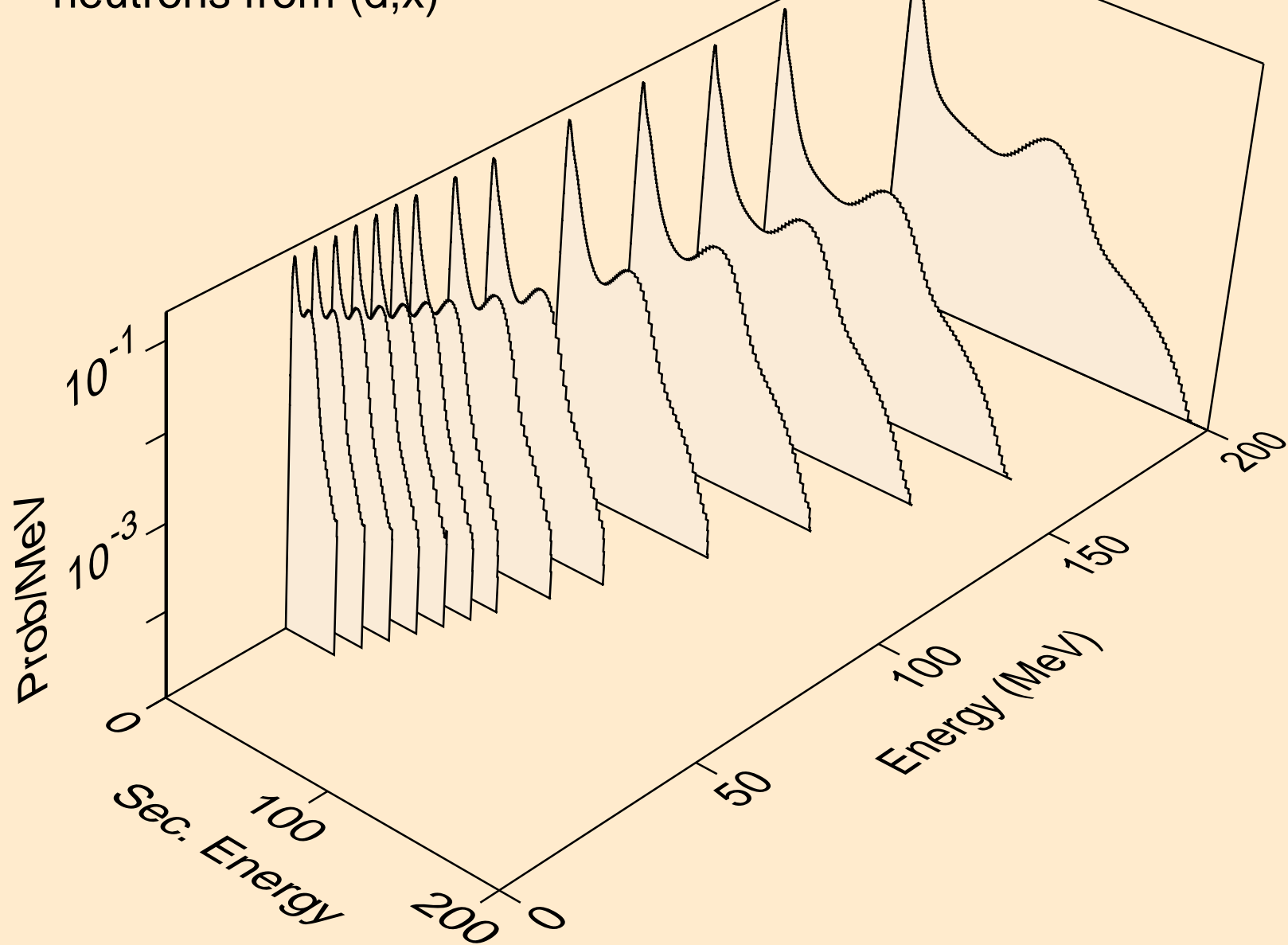

PU233 DEUTERON ACER TENDL-2024 LIBRARY; T=0.K
neutrons from (d,2nd)

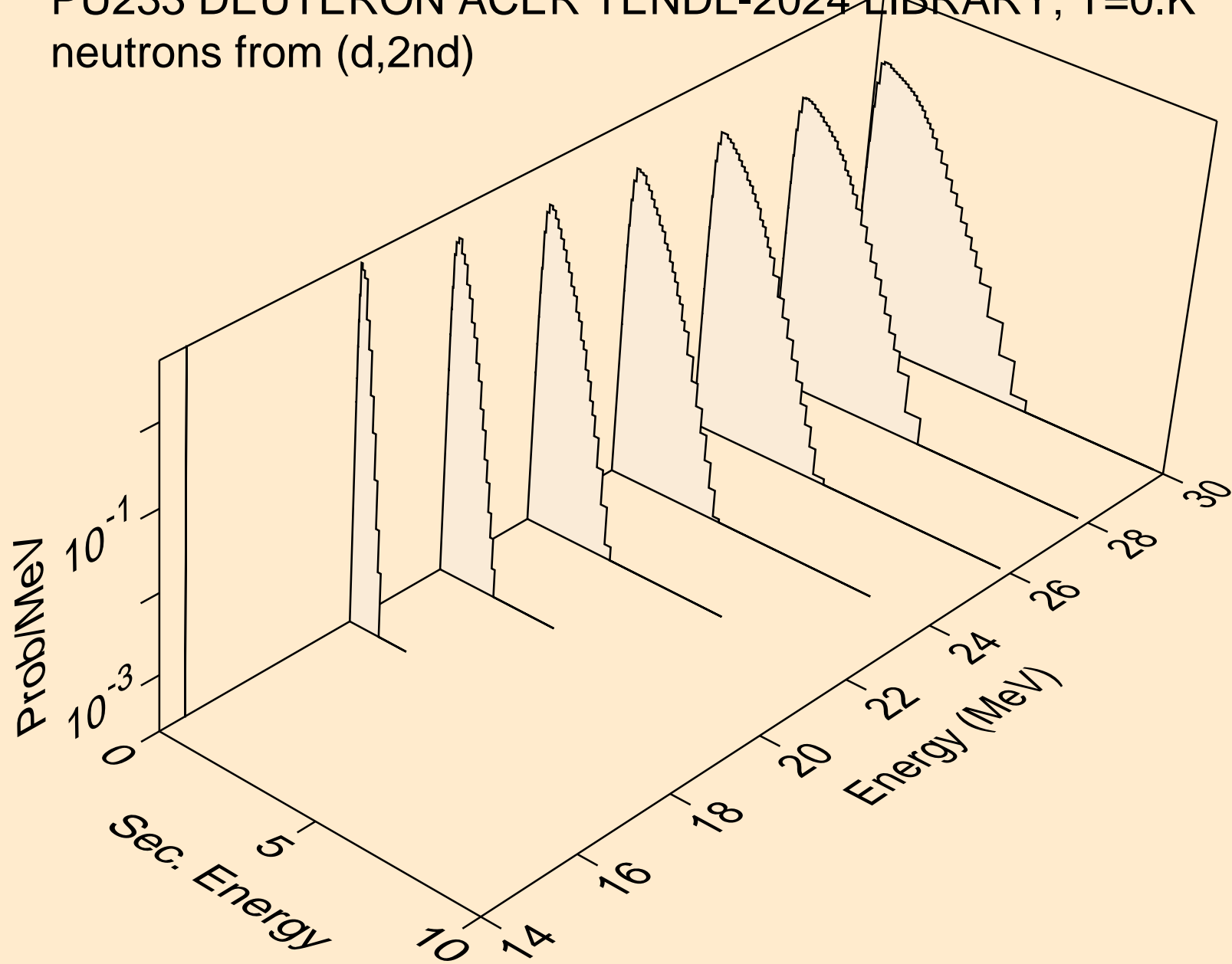

PU233 DEUTERON ACER TENDL-2024 LIBRARY; T=0.K
neutrons from (d,2n)

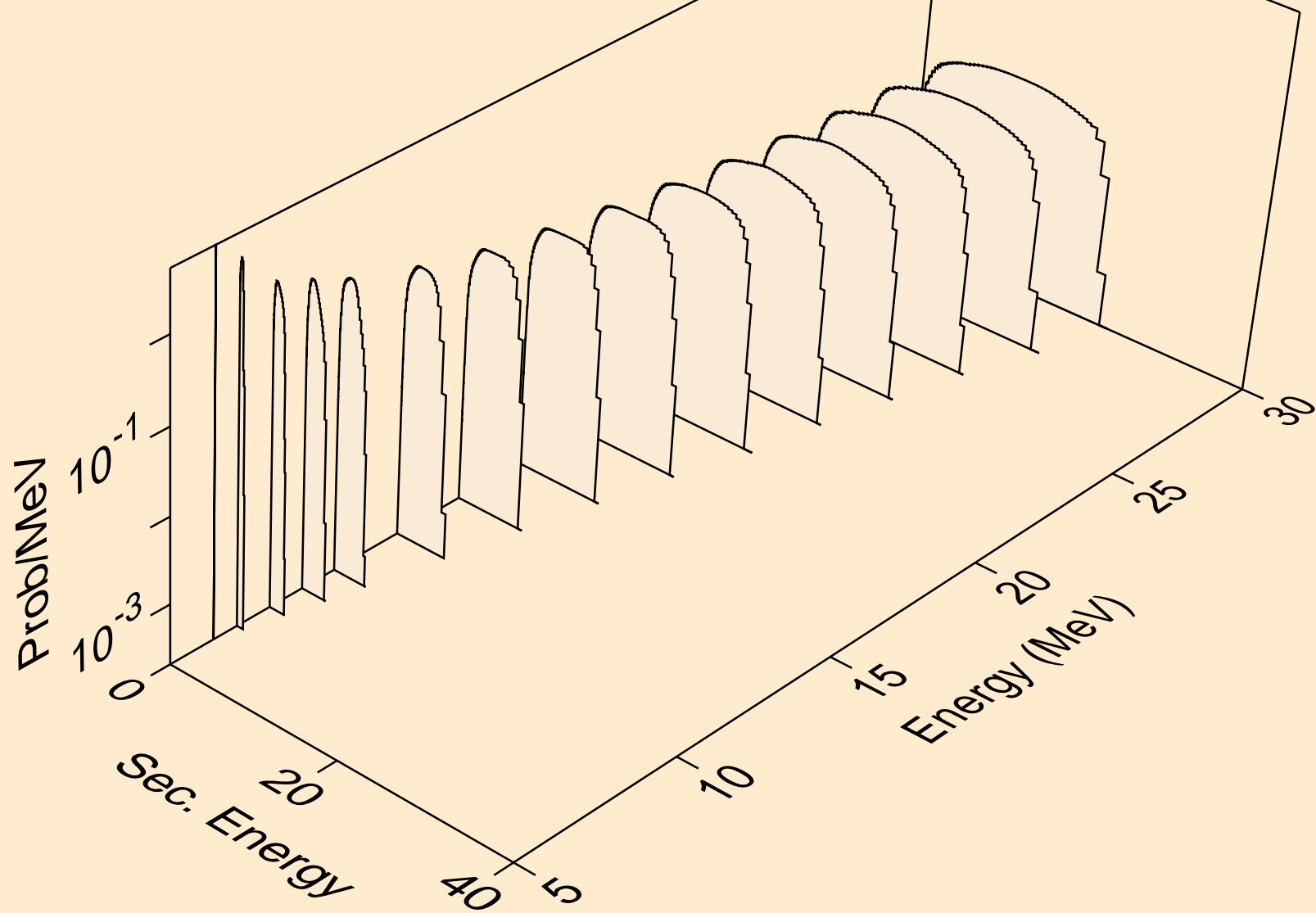

PU233 DEUTERON ACER TENDL-2024 LIBRARY; T=0.K
neutrons from (d,3n)

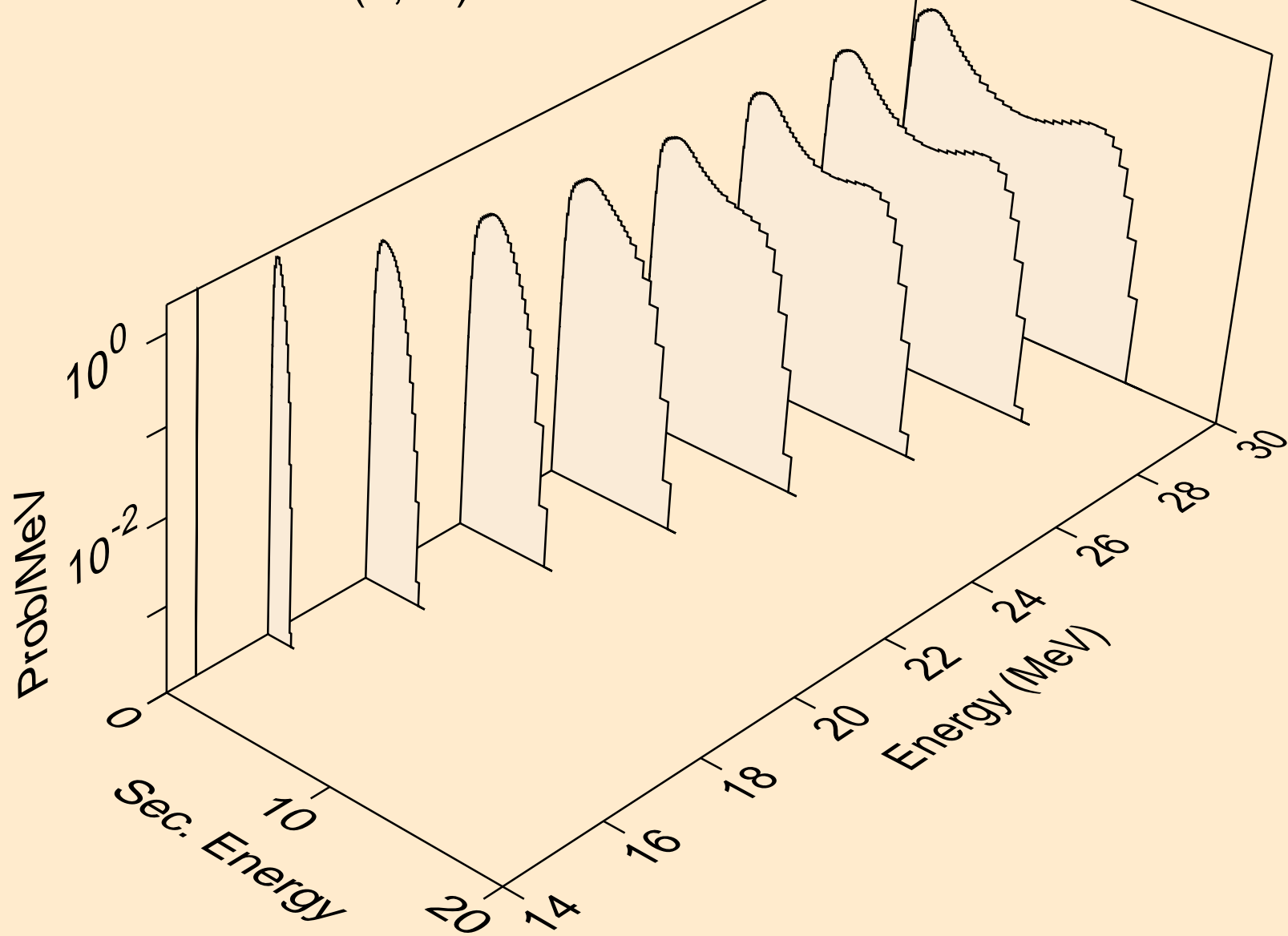

PU233 DEUTERON ACER TENDL-2024 LIBRARY; T=0.K
neutrons from (d,n*)a

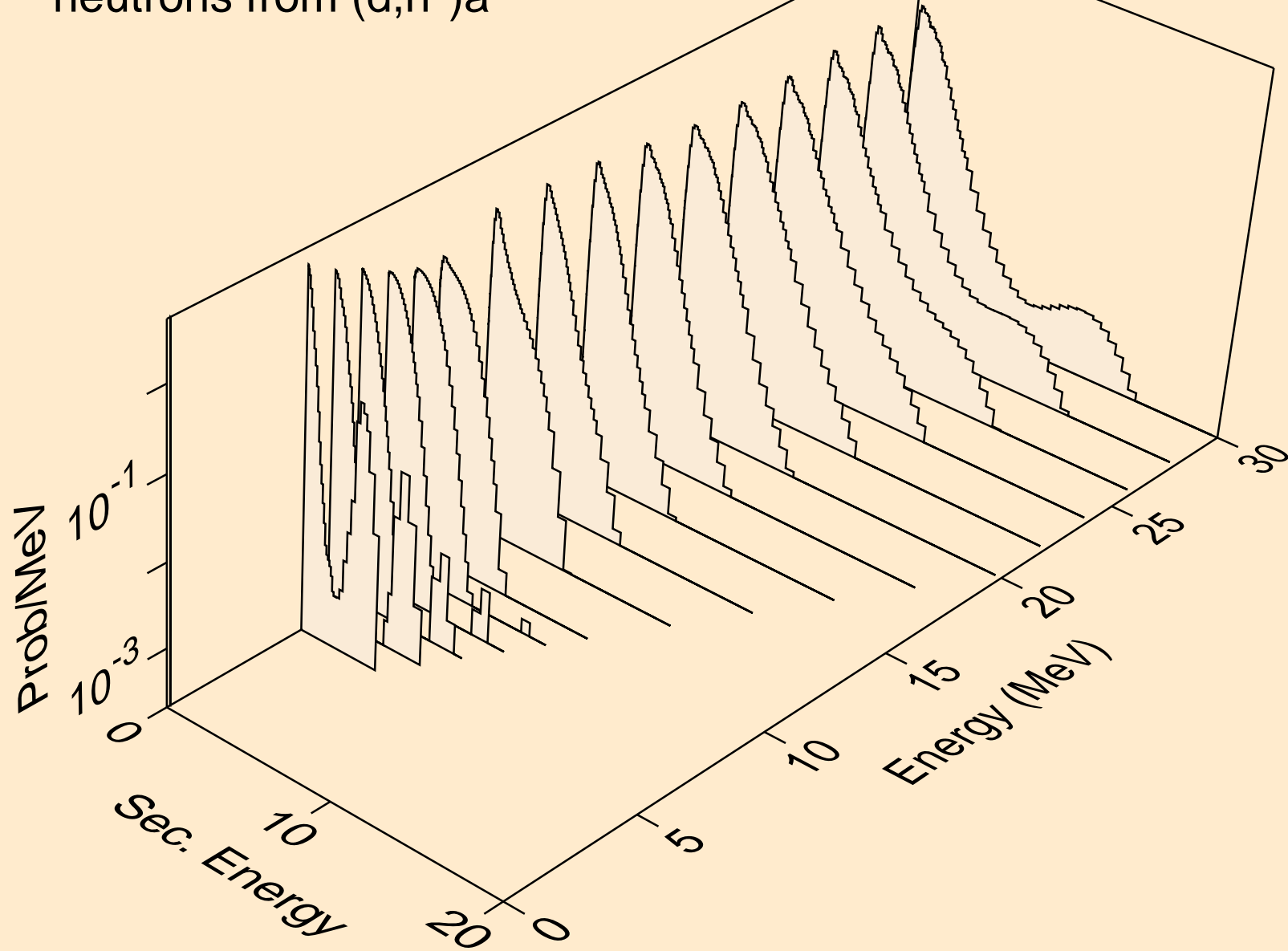

PU233 DEUTERON ACER TENDL-2024 LIBRARY; T=0.K
neutrons from (d,2n)a

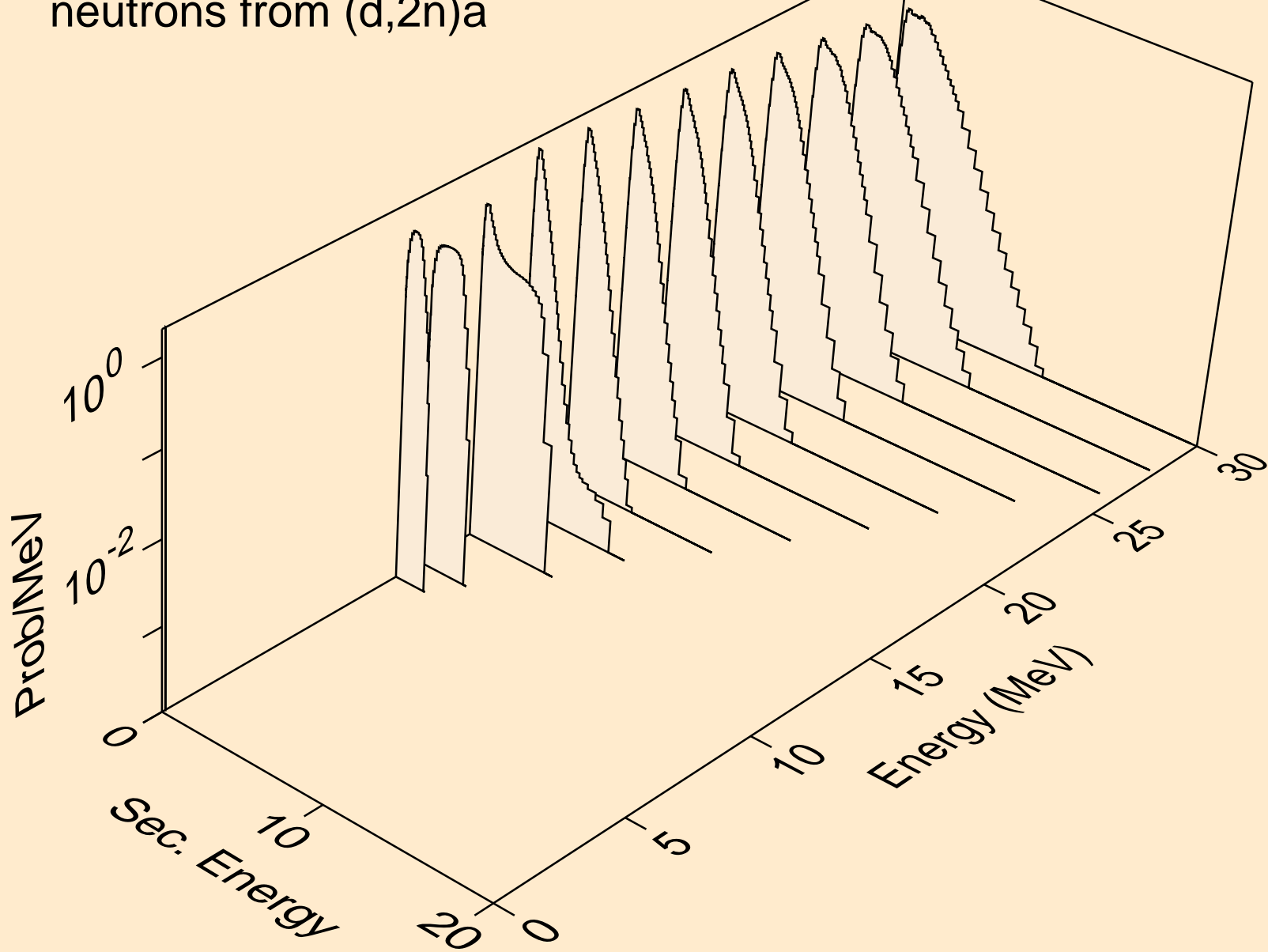

PU233 DEUTERON ACER TENDL-2024 LIBRARY; T=0.K
neutrons from (d,3n)a

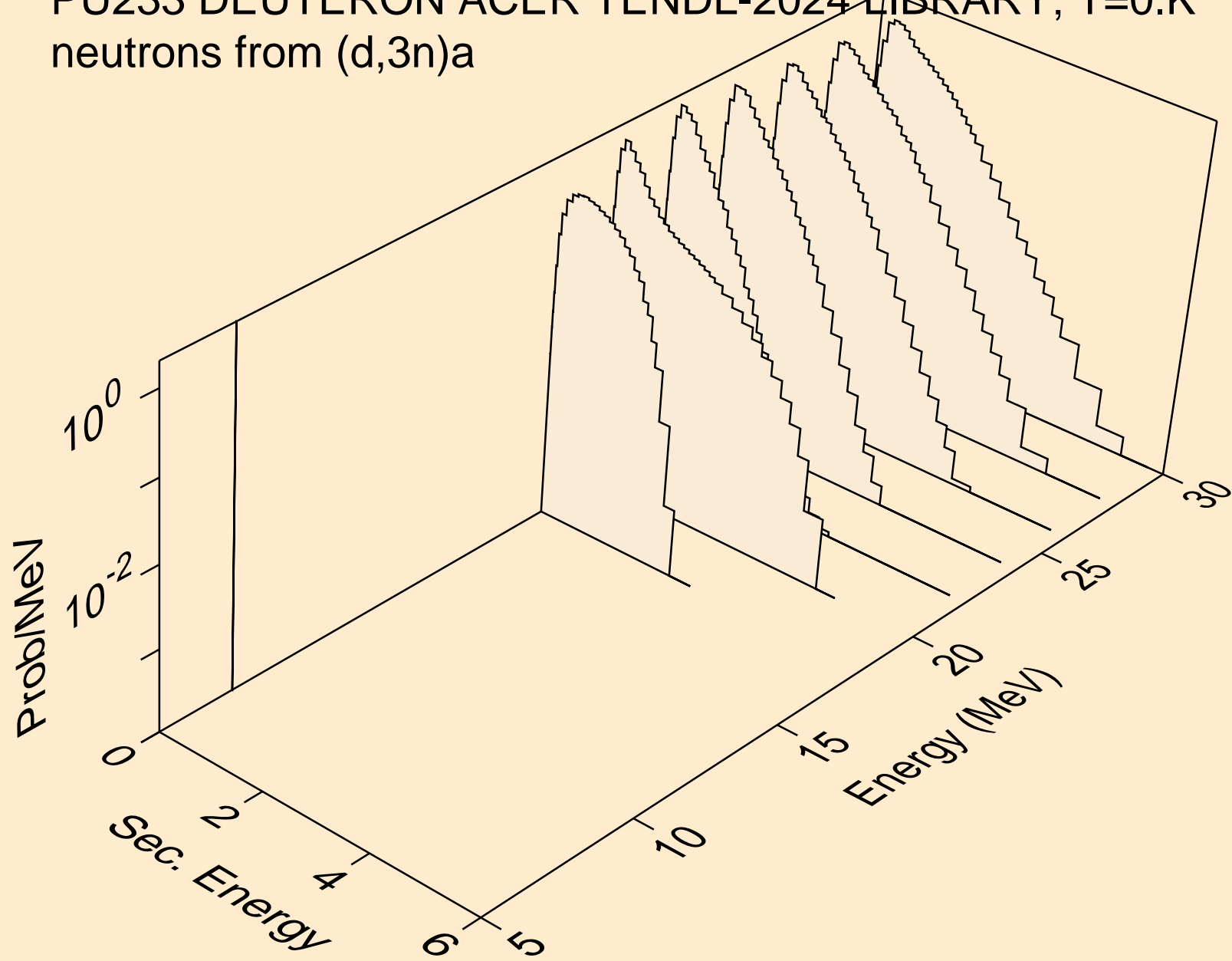

PU233 DEUTERON ACER TENDL-2024 LIBRARY; T=0.K
neutrons from (d,n*)p

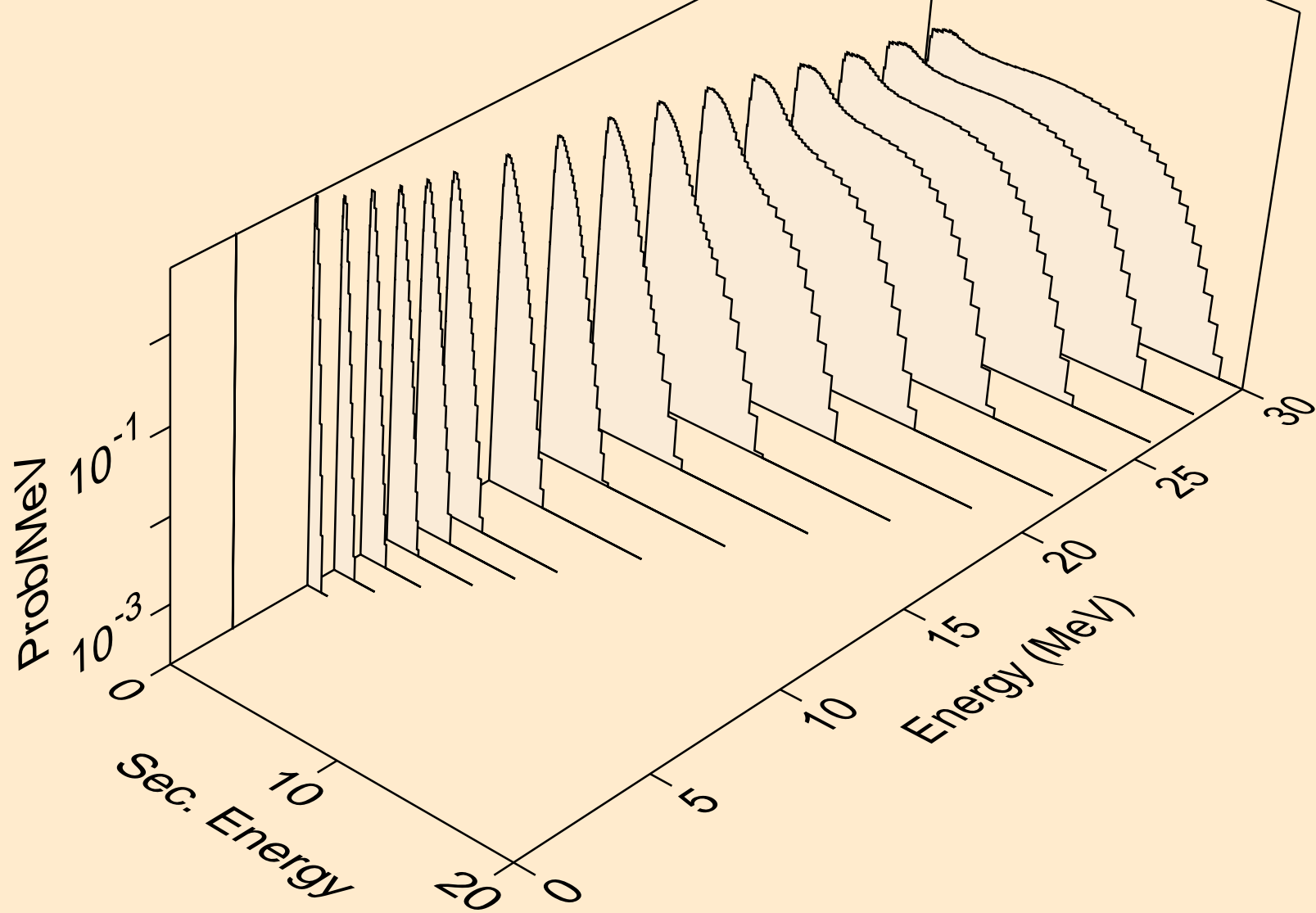

PU233 DEUTERON ACER TENDL-2024 LIBRARY; T=0.K
neutrons from (d,n*)2a

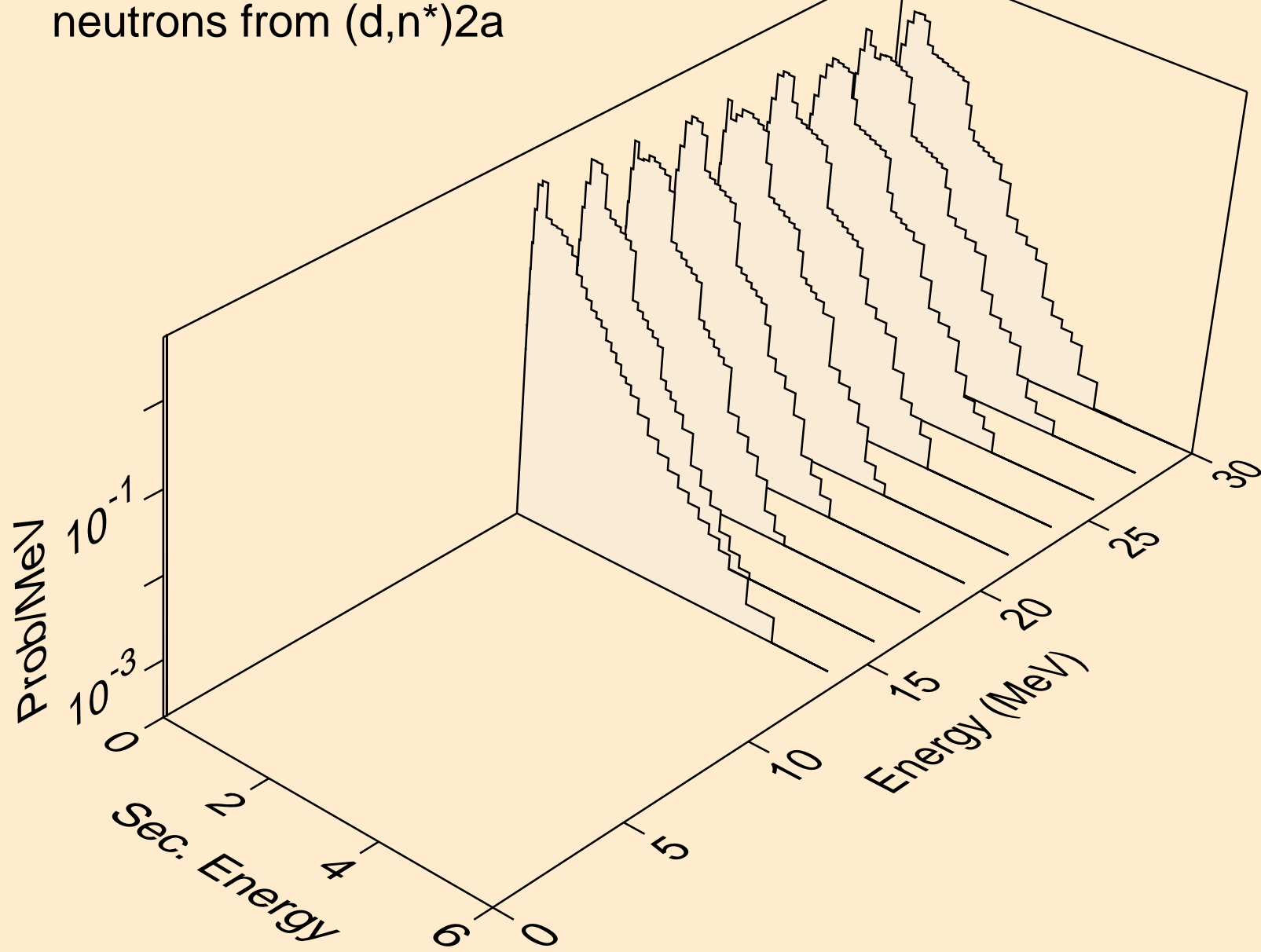

PU233 DEUTERON ACER TENDL-2024 LIBRARY; T=0.K
neutrons from (d,n*)d

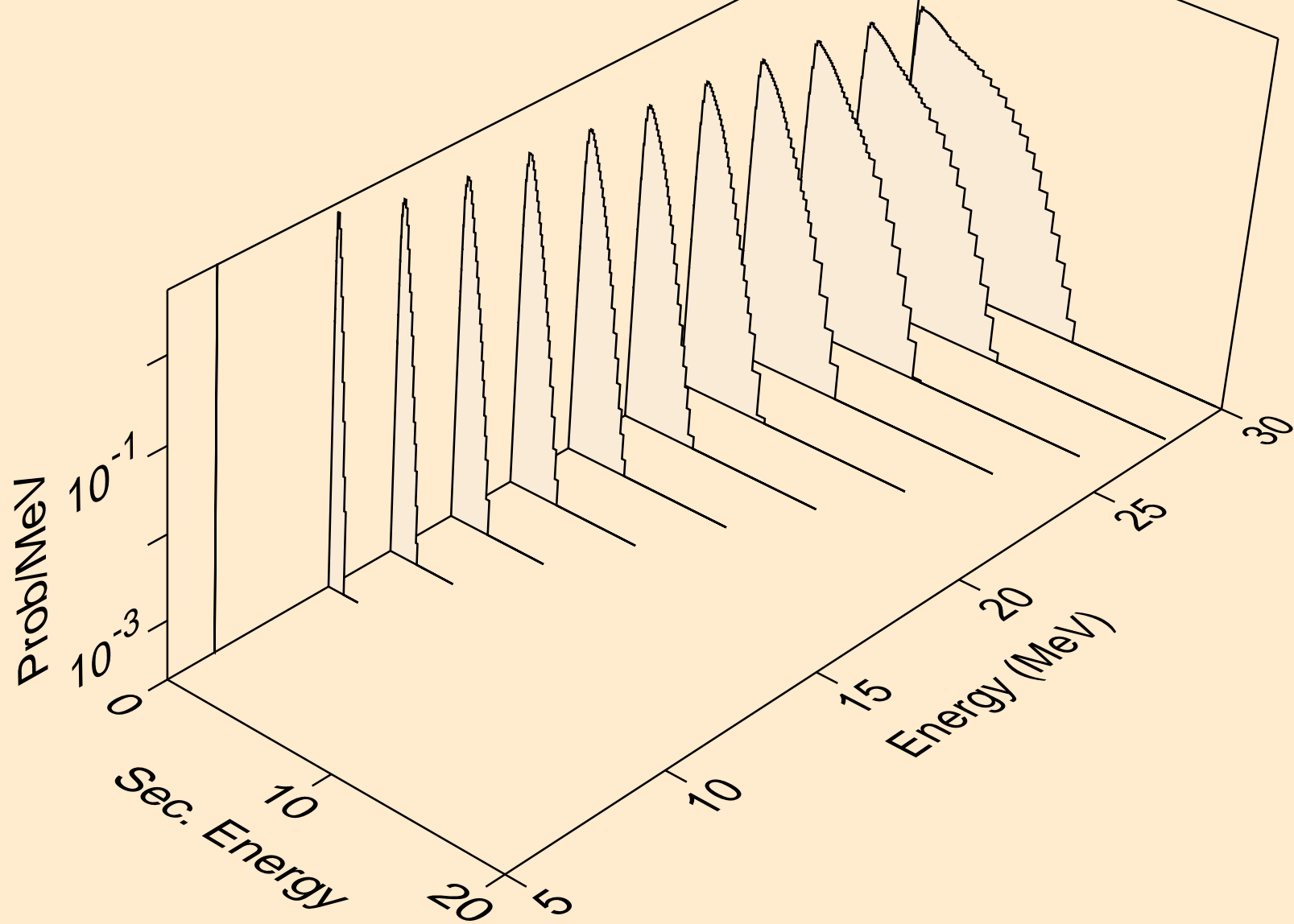

PU233 DEUTERON ACER TENDL-2024 LIBRARY; T=0.K
neutrons from (d,n*)t

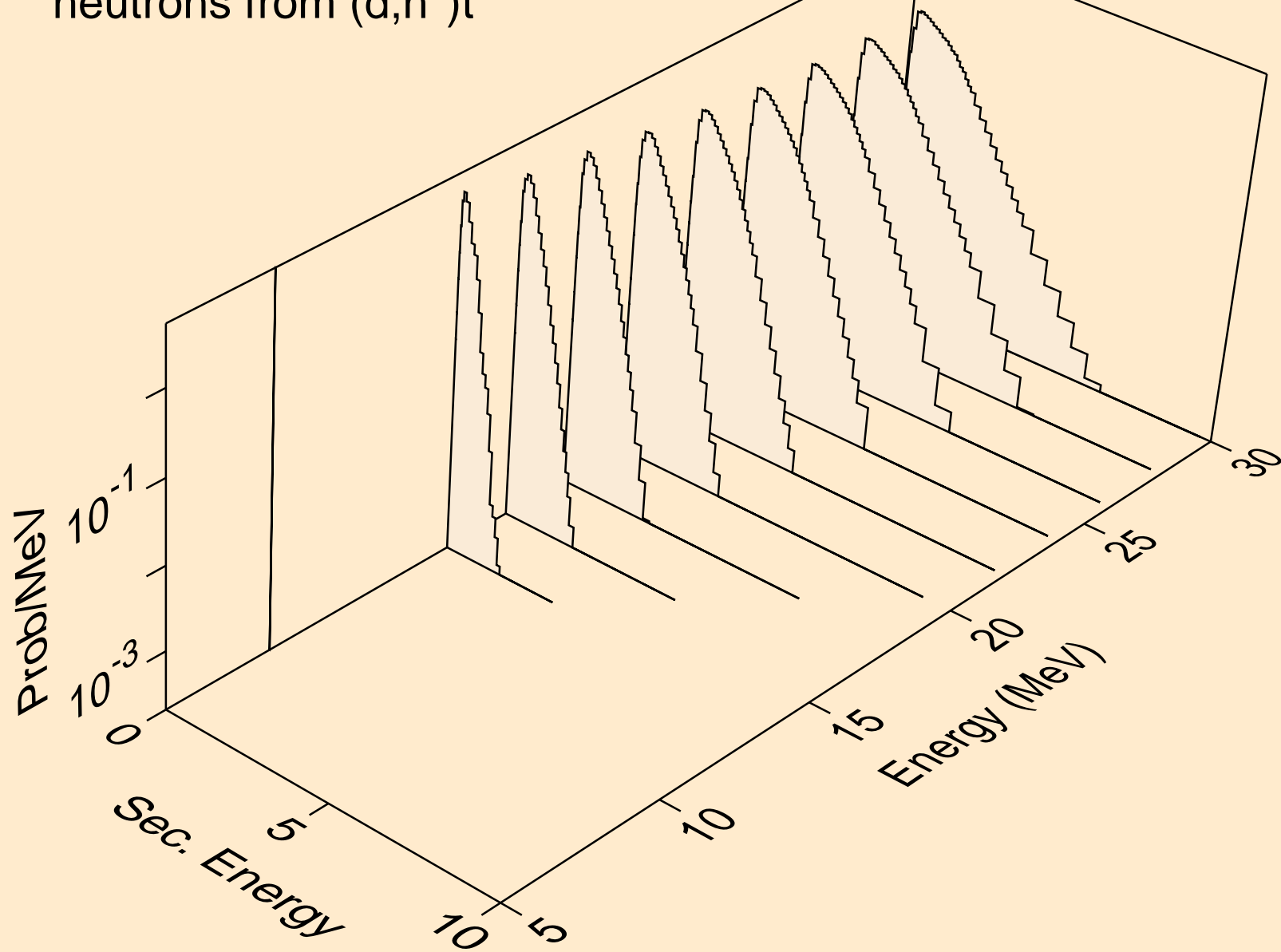

PU233 DEUTERON ACER TENDL-2024 LIBRARY; T=0.K
neutrons from (d,n*)he3

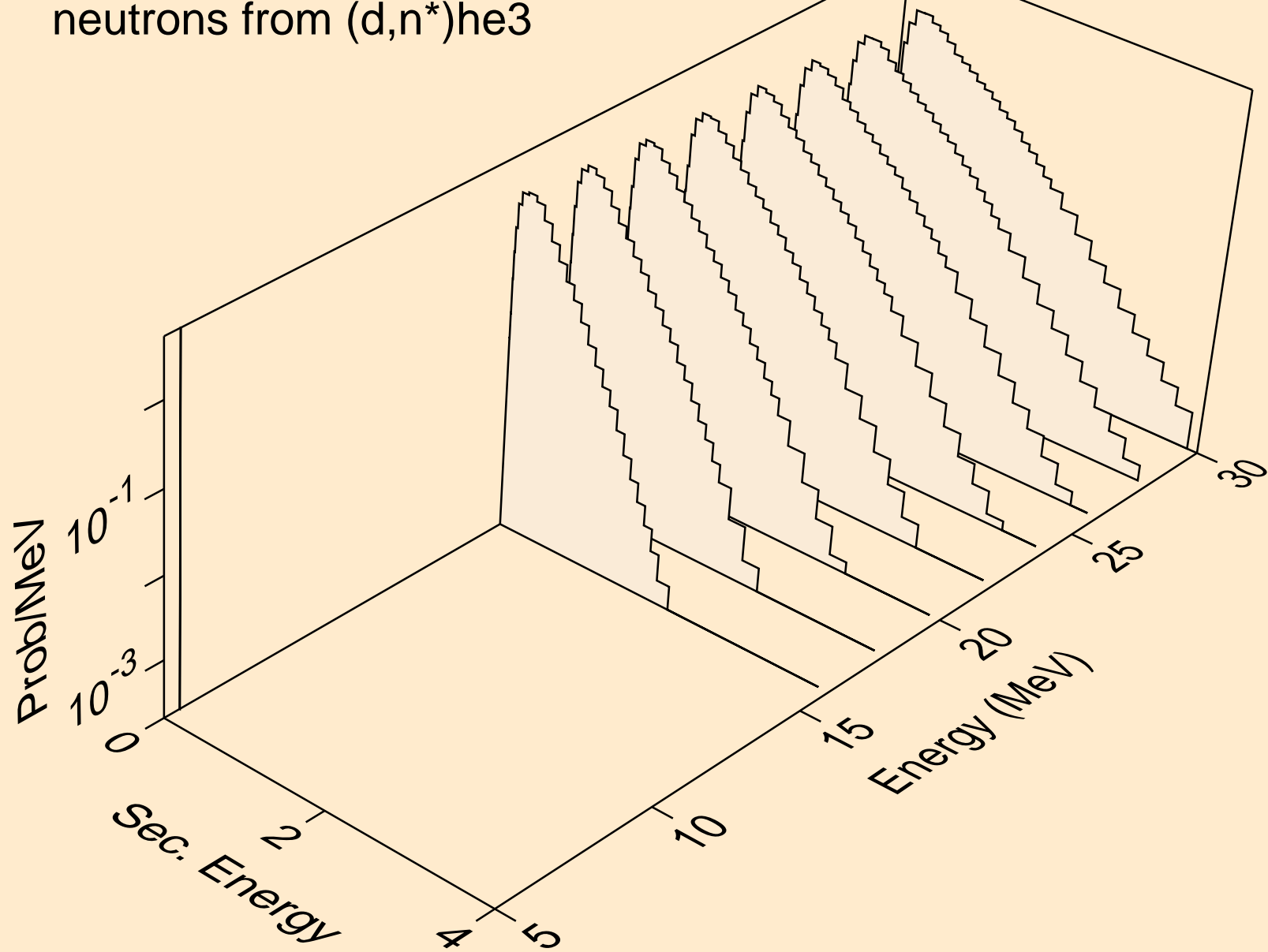

PU233 DEUTERON ACER TENDL-2024 LIBRARY; T=0.K
neutrons from (d,4n)

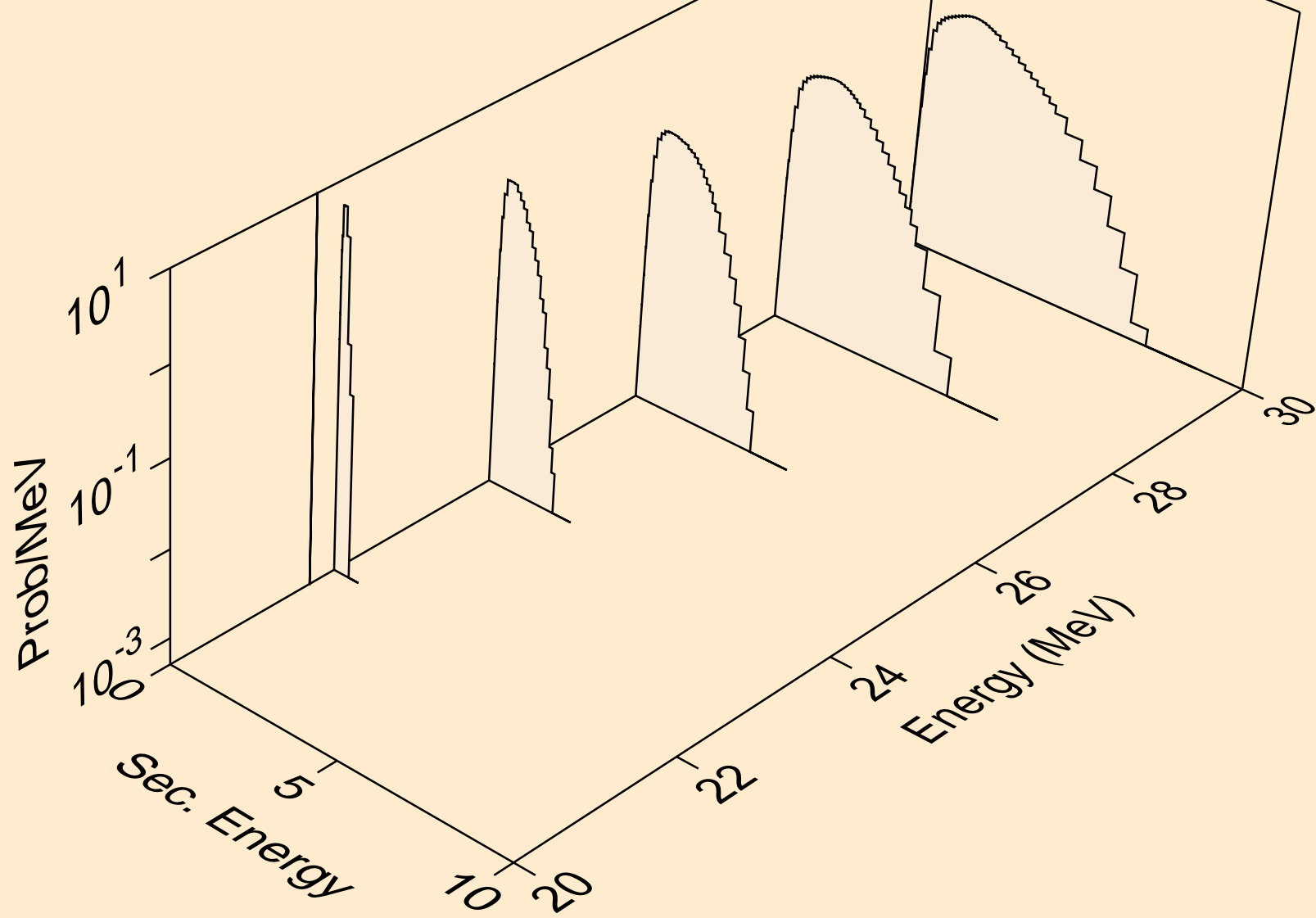

PU233 DEUTERON ACER TENDL-2024 LIBRARY; T=0.K
neutrons from (d,2np)

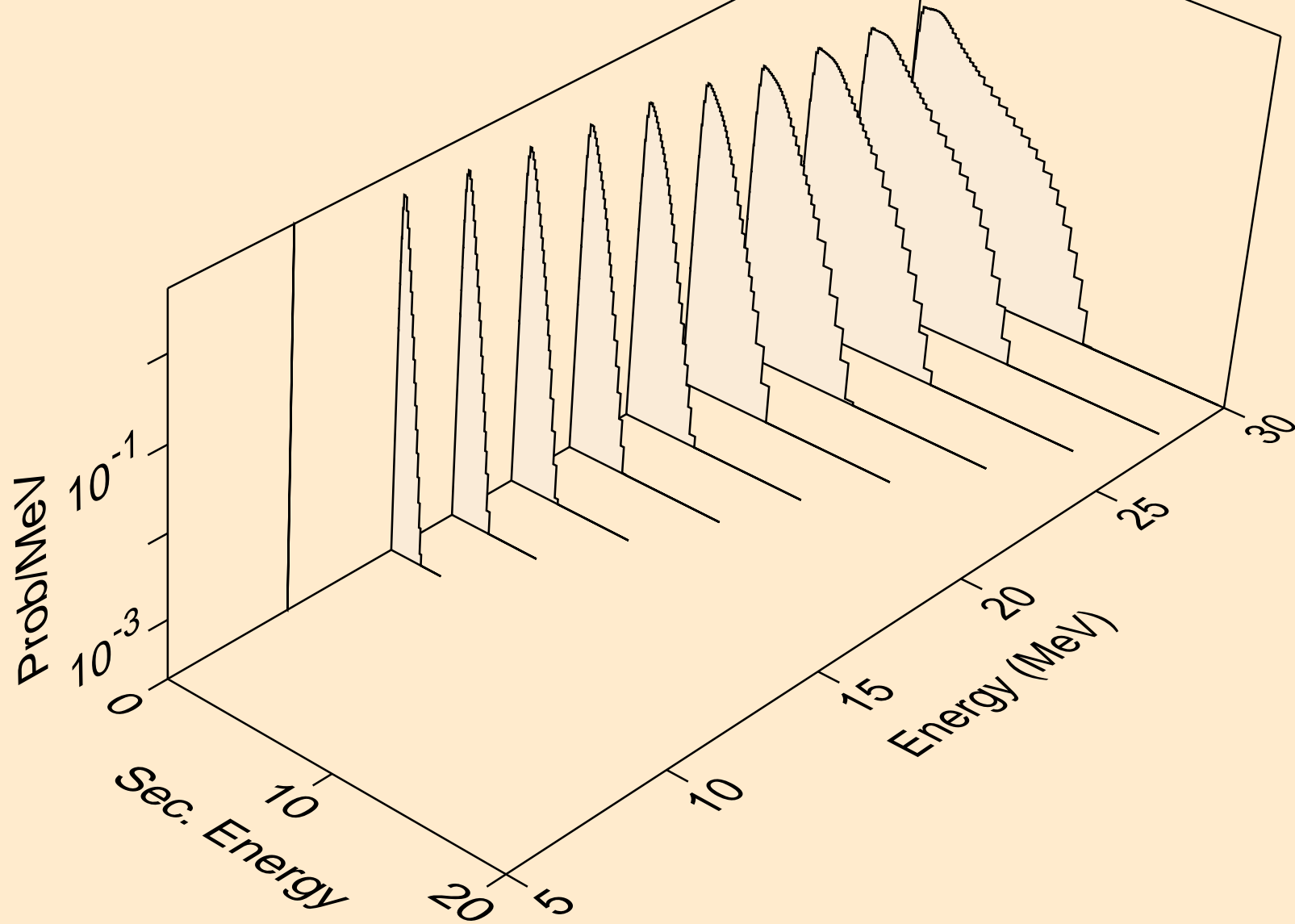

PU233 DEUTERON ACER TENDL-2024 LIBRARY; T=0.K
neutrons from (d,3np)

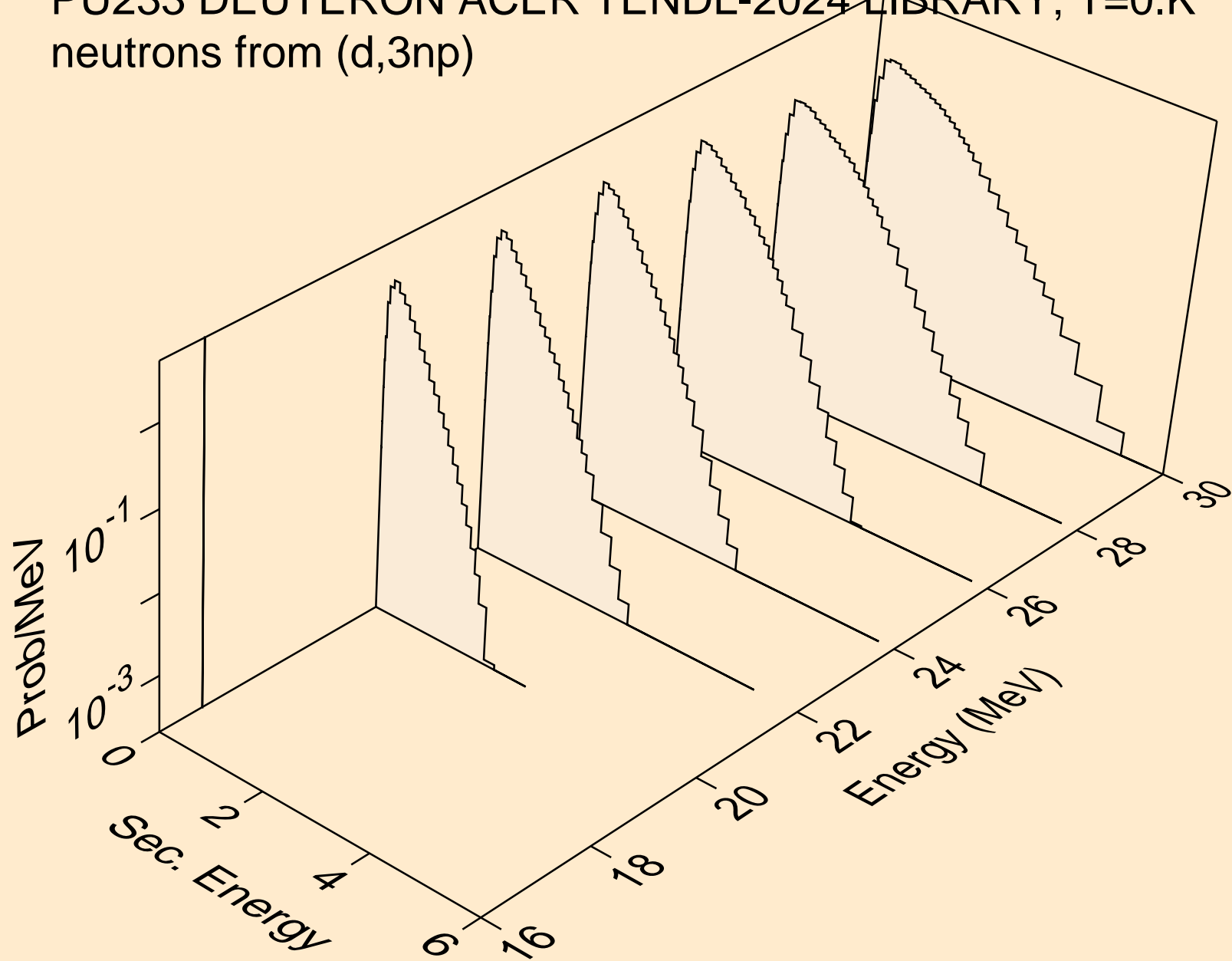

PU233 DEUTERON ACER TENDL-2024 LIBRARY; T=0.K
neutrons from (d,n2p)

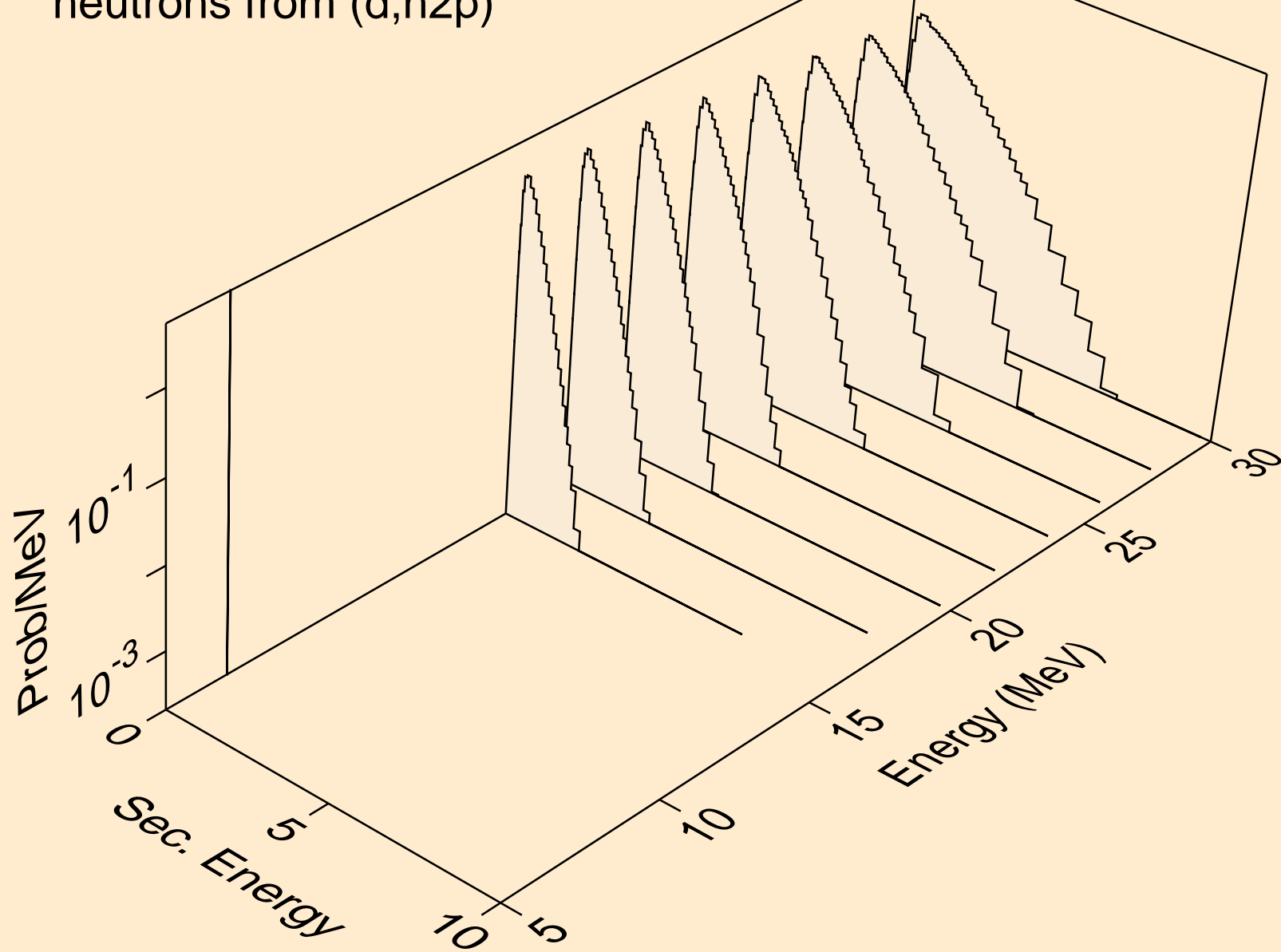

PU233 DEUTERON ACER TENDL-2024 LIBRARY; T=0.K
neutrons from (d,npa)

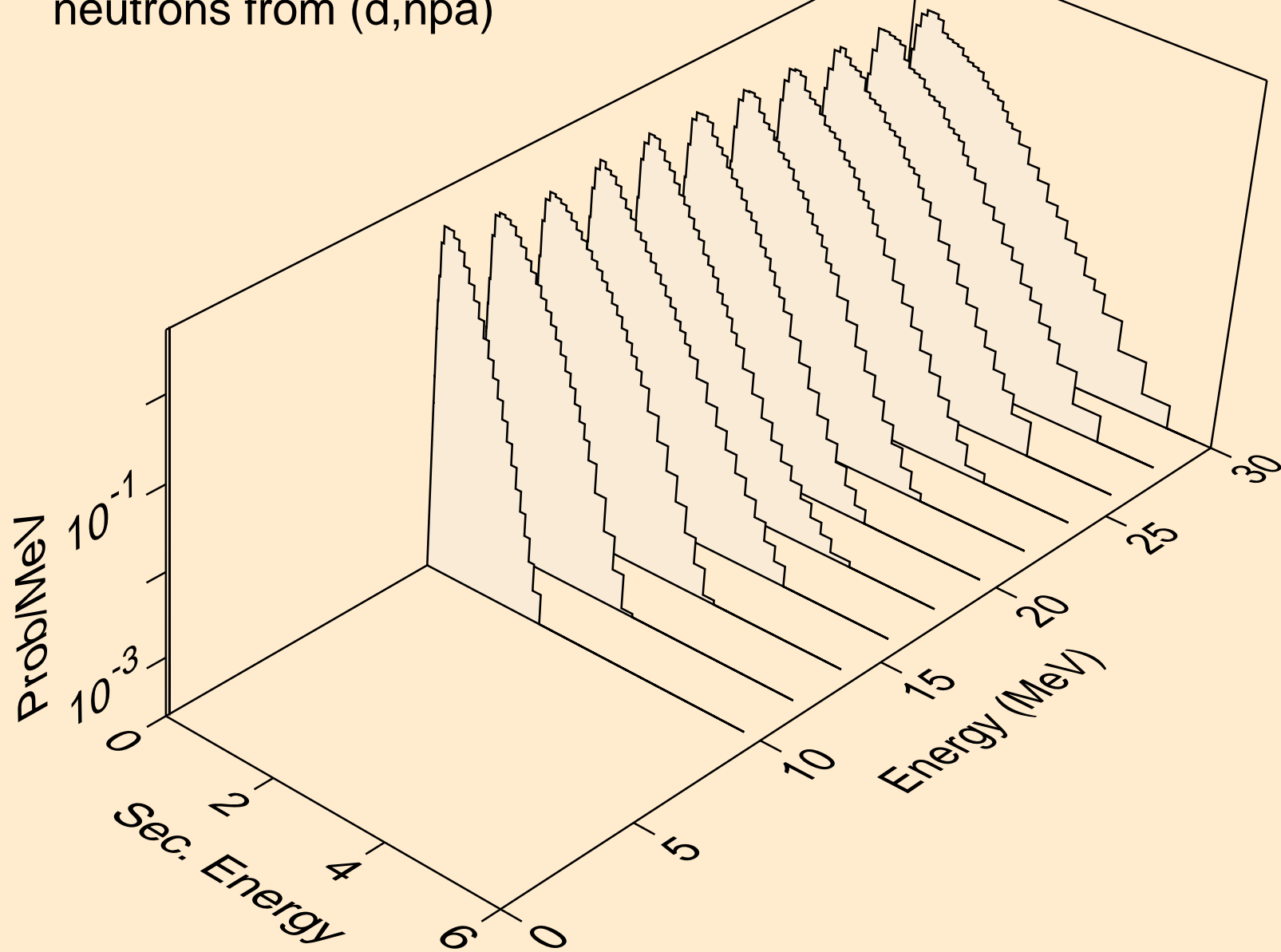

PU233 DEUTERON ACER TENDL-2024 LIBRARY; T=0.K
protons from (d,x)

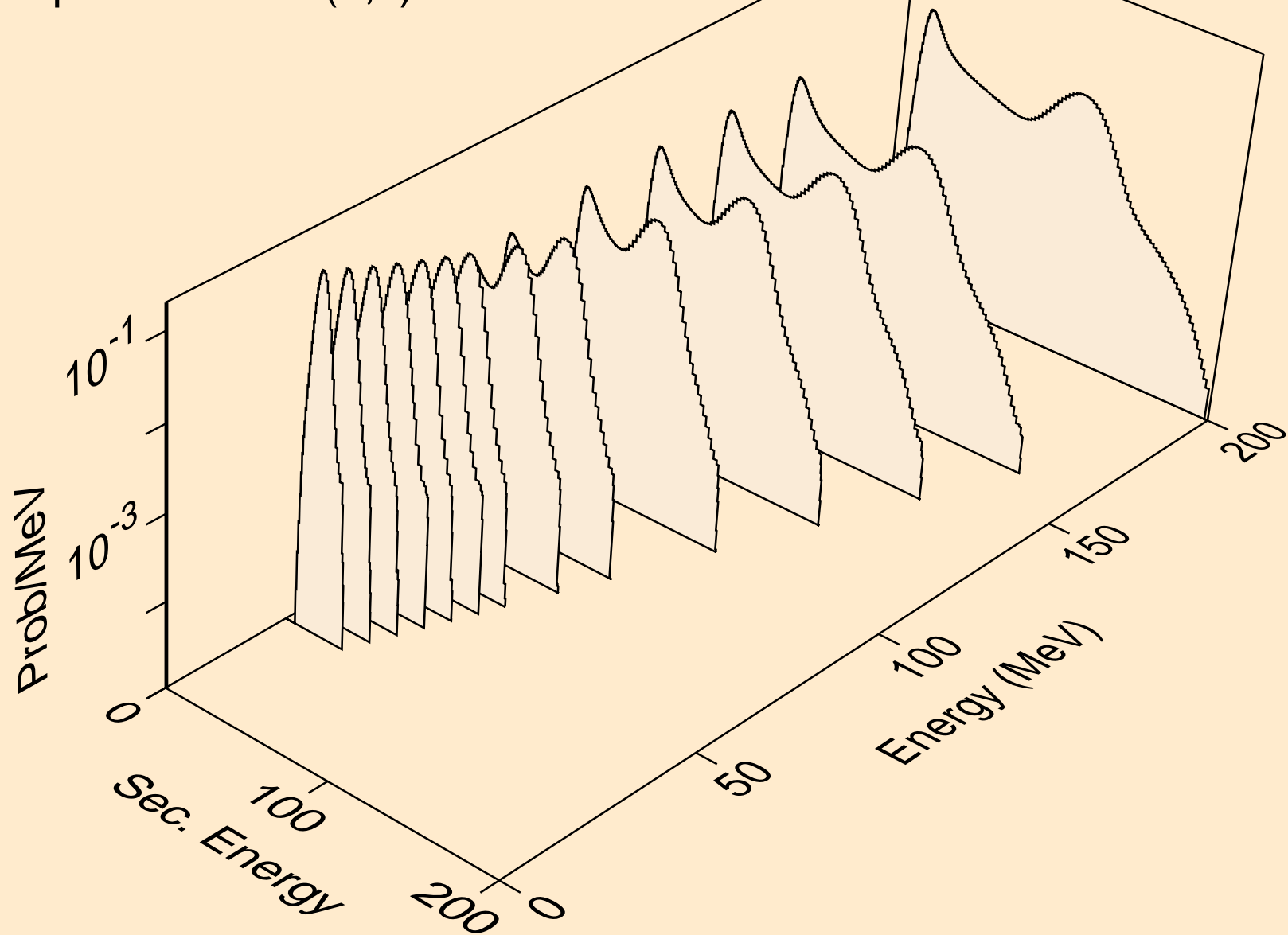

PU233 DEUTERON ACER TENDL-2024 LIBRARY; T=0.K
protons from (d,n*)p

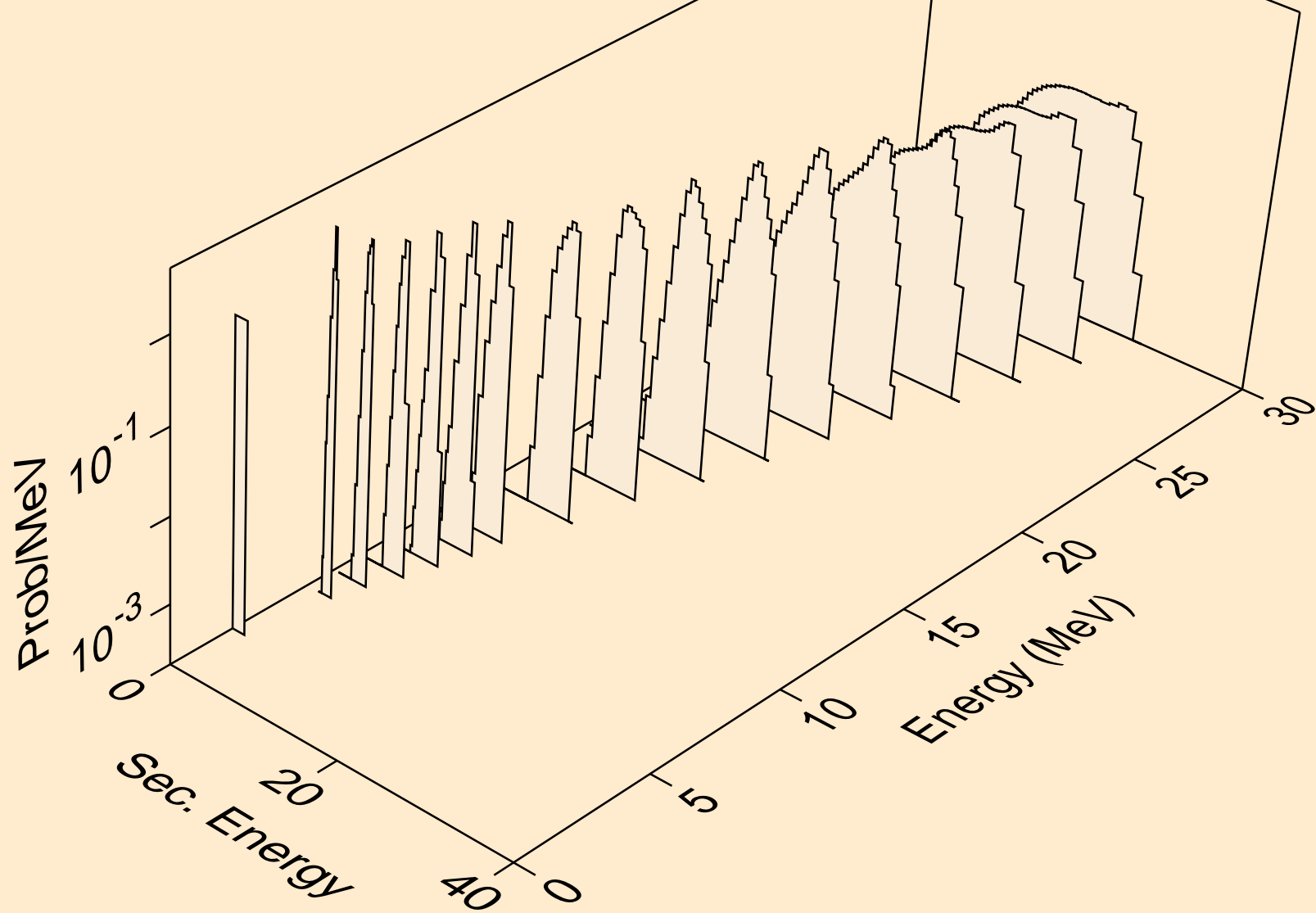

PU233 DEUTERON ACER TENDL-2024 LIBRARY; T=0.K
protons from (d,2np)

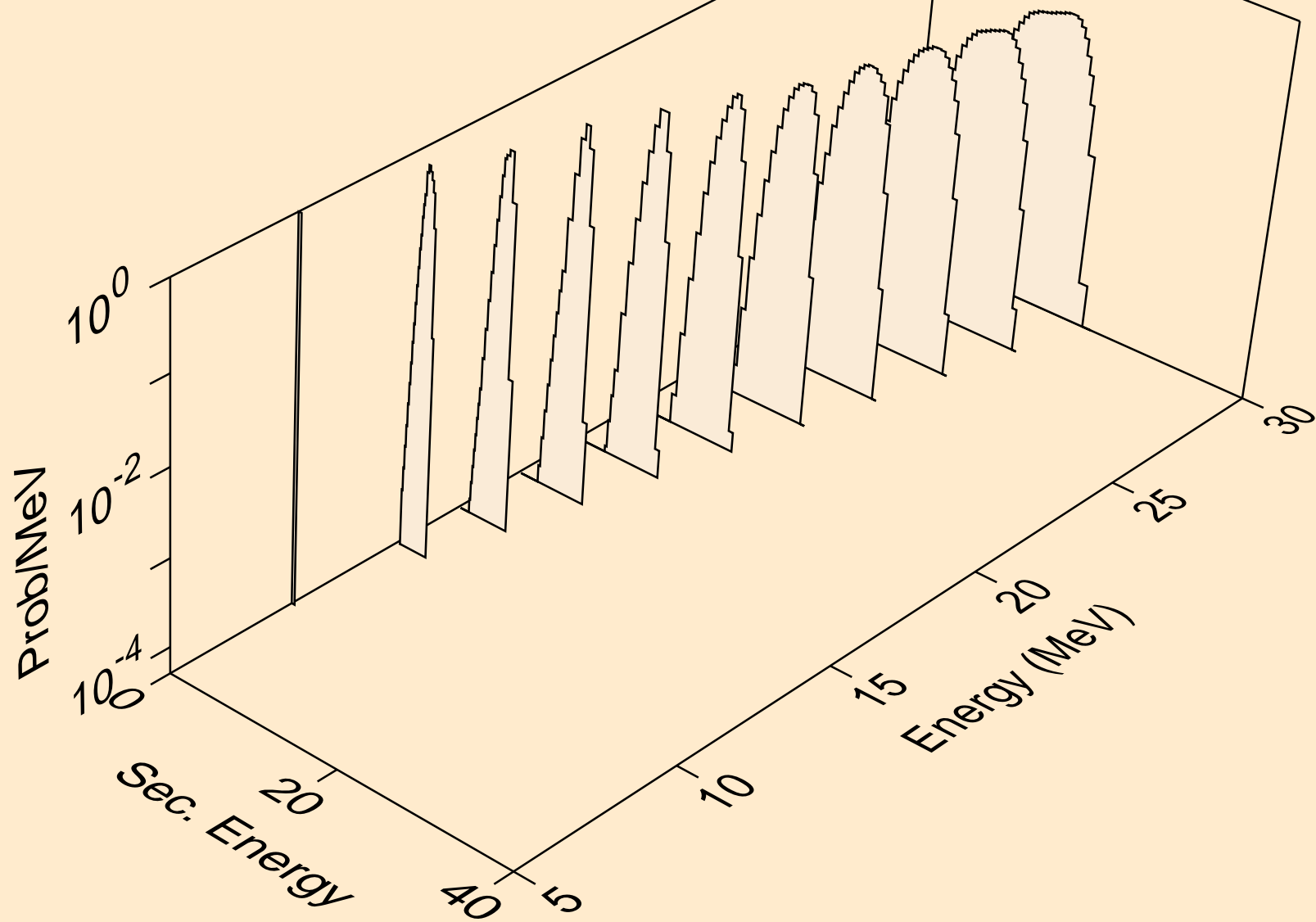

PU233 DEUTERON ACER TENDL-2024 LIBRARY; T=0.K
protons from (d,3np)

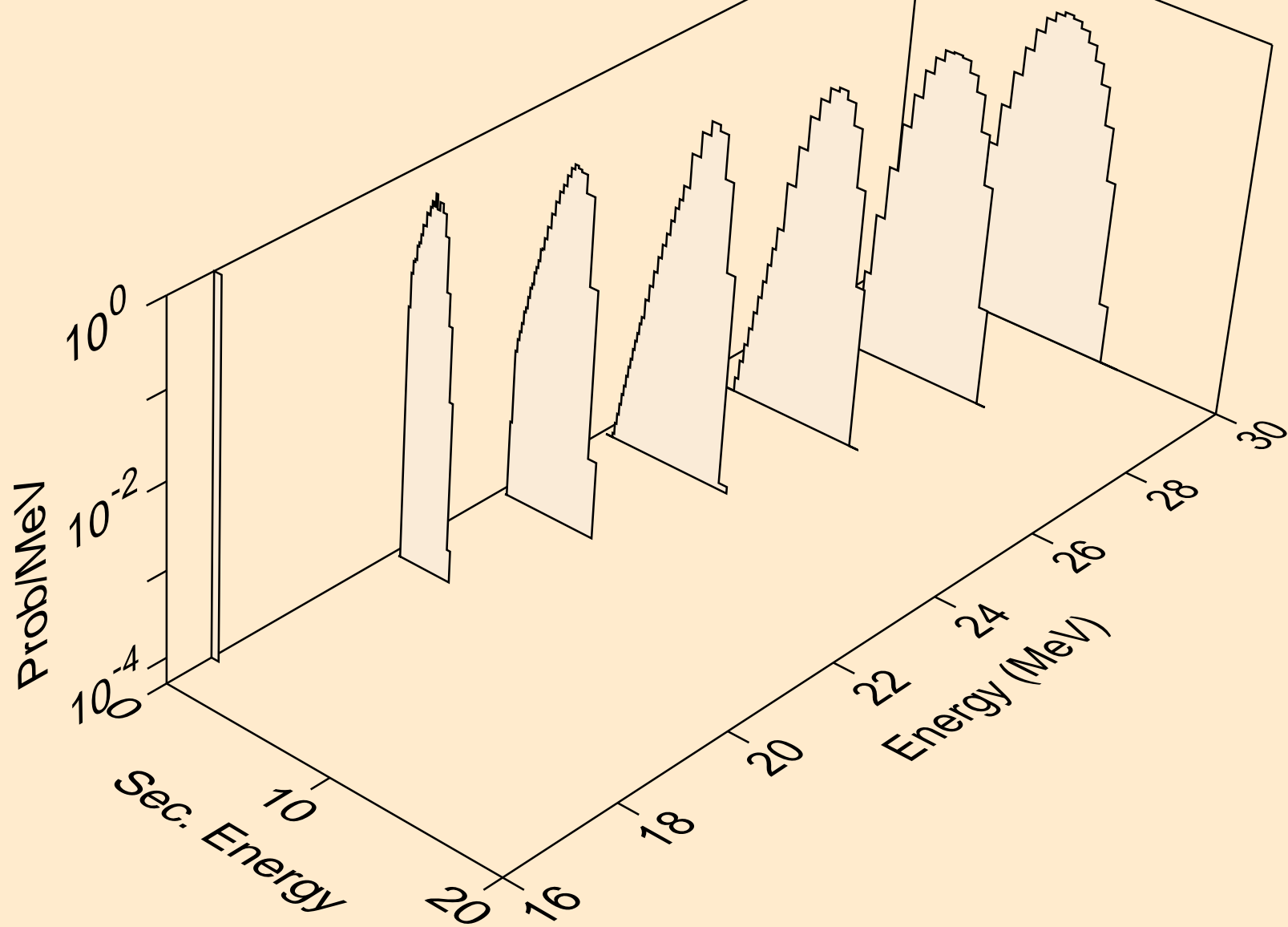

PU233 DEUTERON ACER TENDL-2024 LIBRARY; T=0.K
protons from (d,n2p)

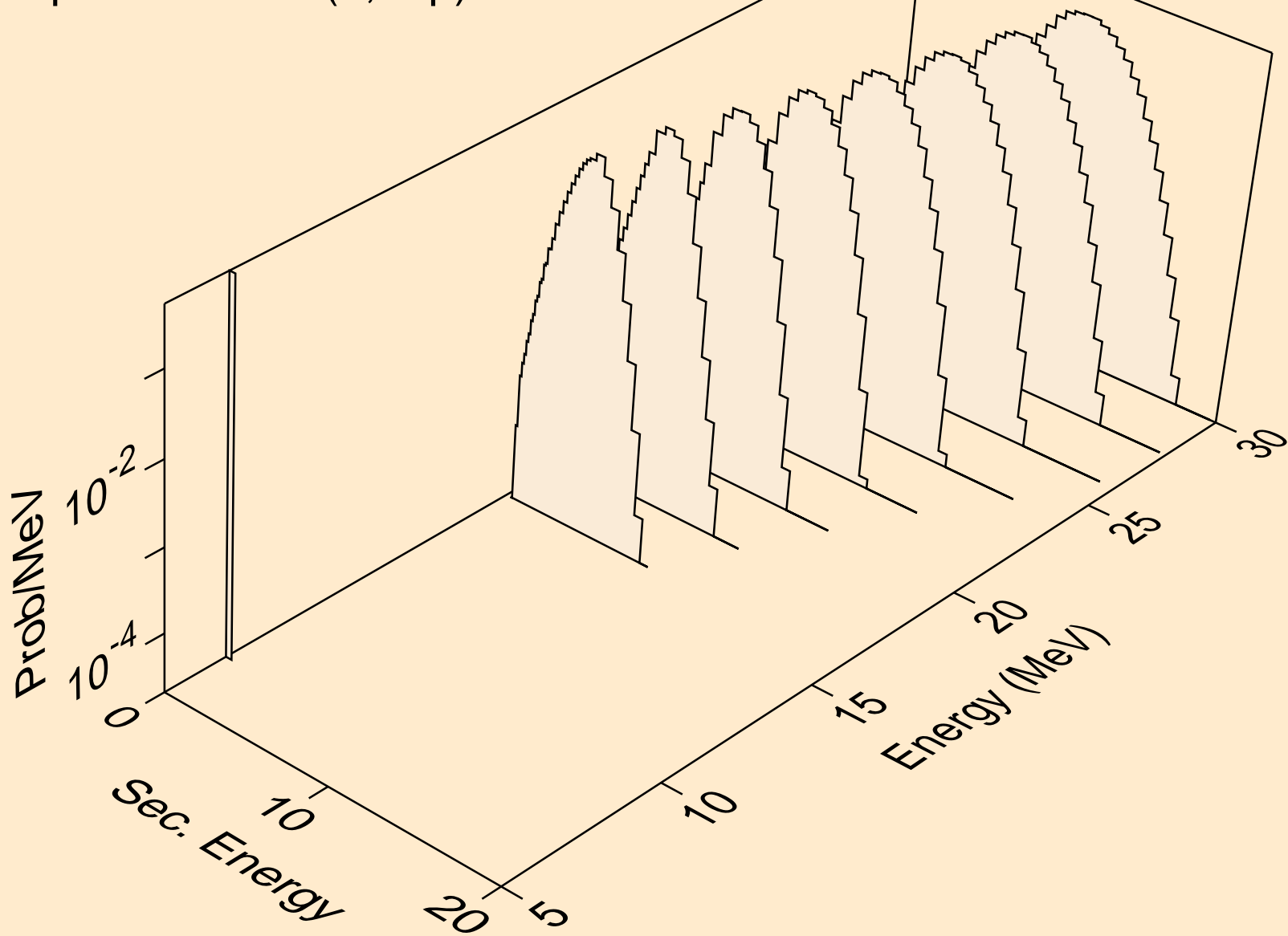

PU233 DEUTERON ACER TENDL-2024 LIBRARY; T=0.K
protons from (d,npa)

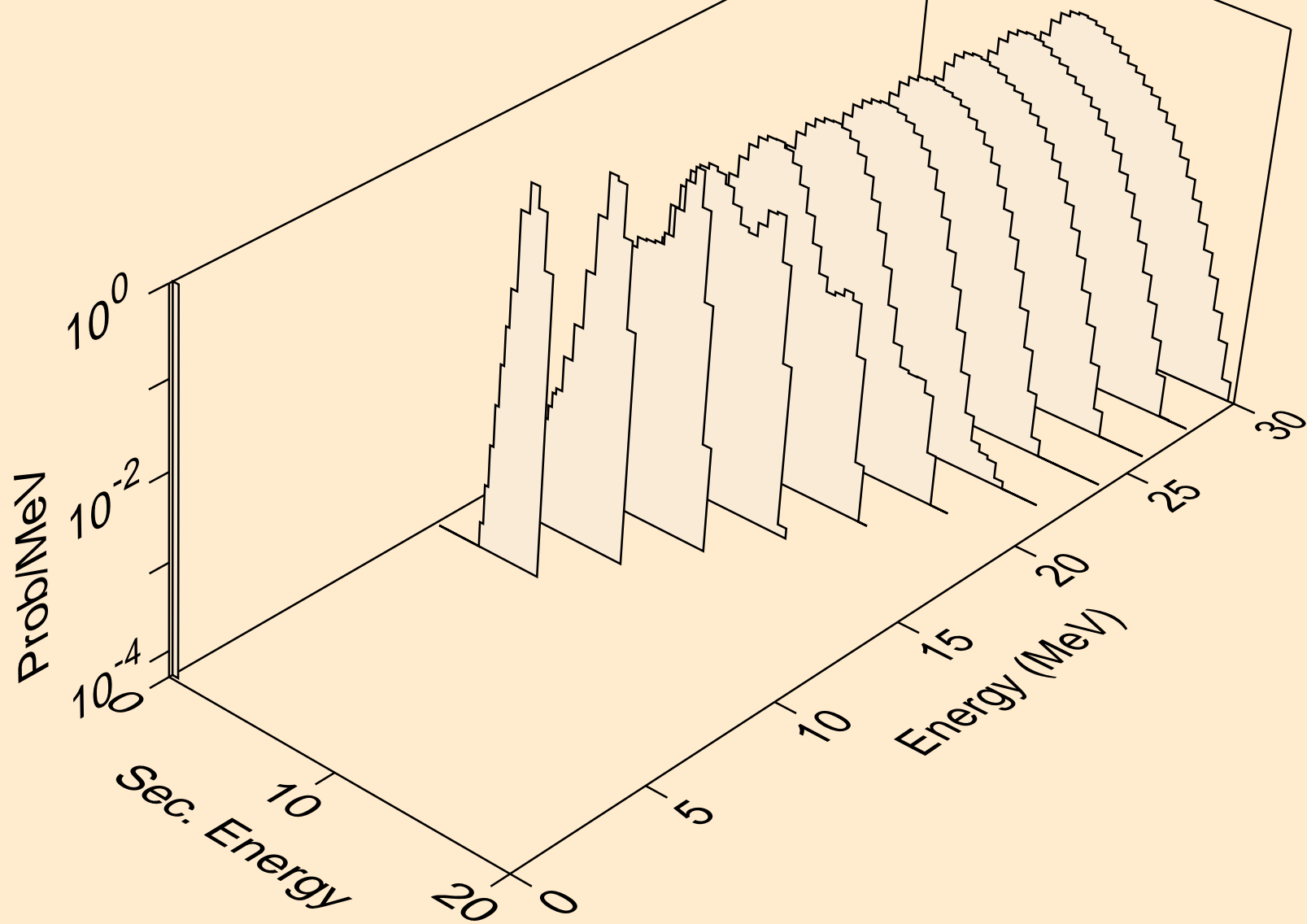

PU233 DEUTERON ACER TENDL-2024 LIBRARY; T=0.K
protons from (d,p)

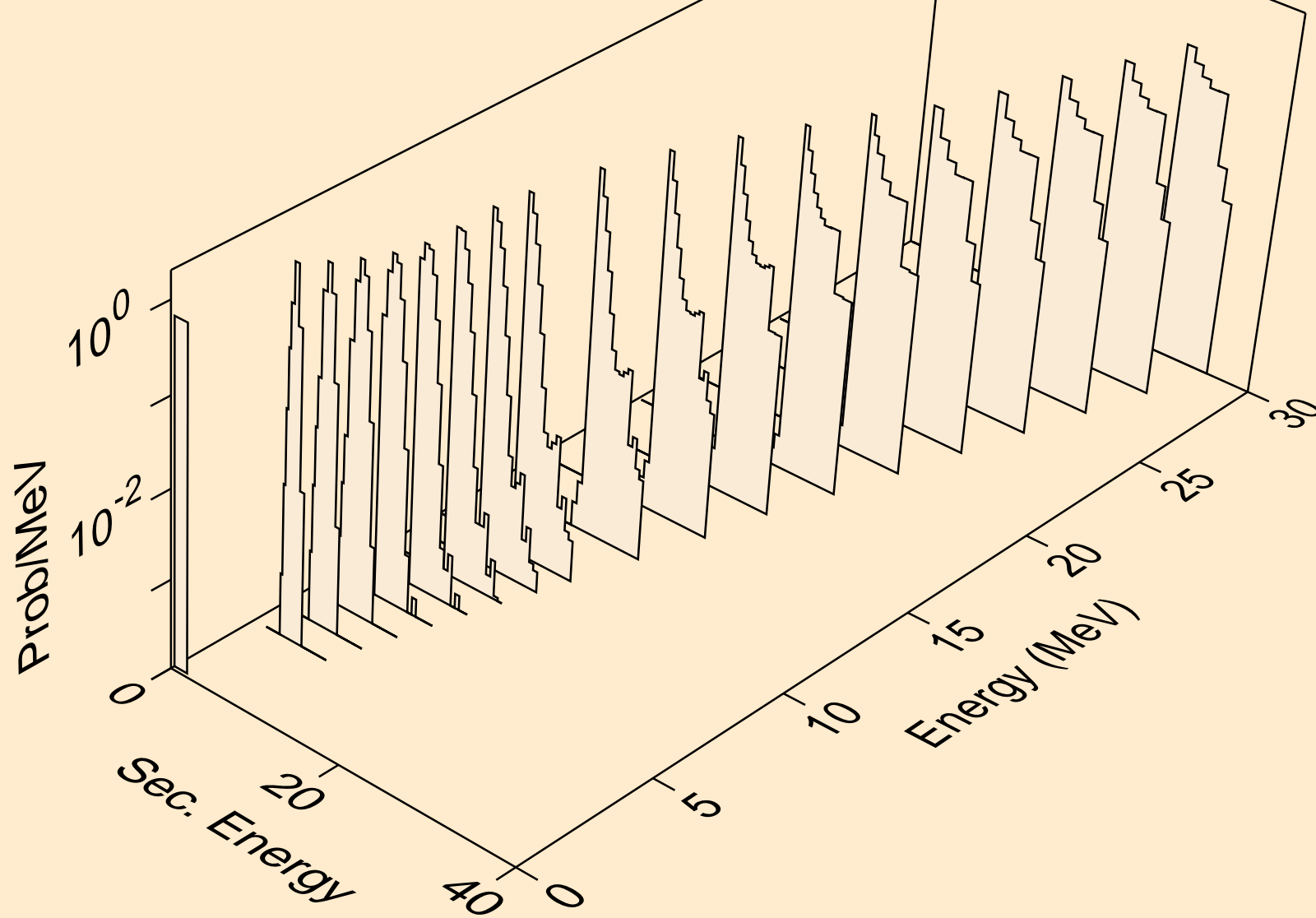

PU233 DEUTERON ACER TENDL-2024 LIBRARY; T=0.K
protons from (d,2p)

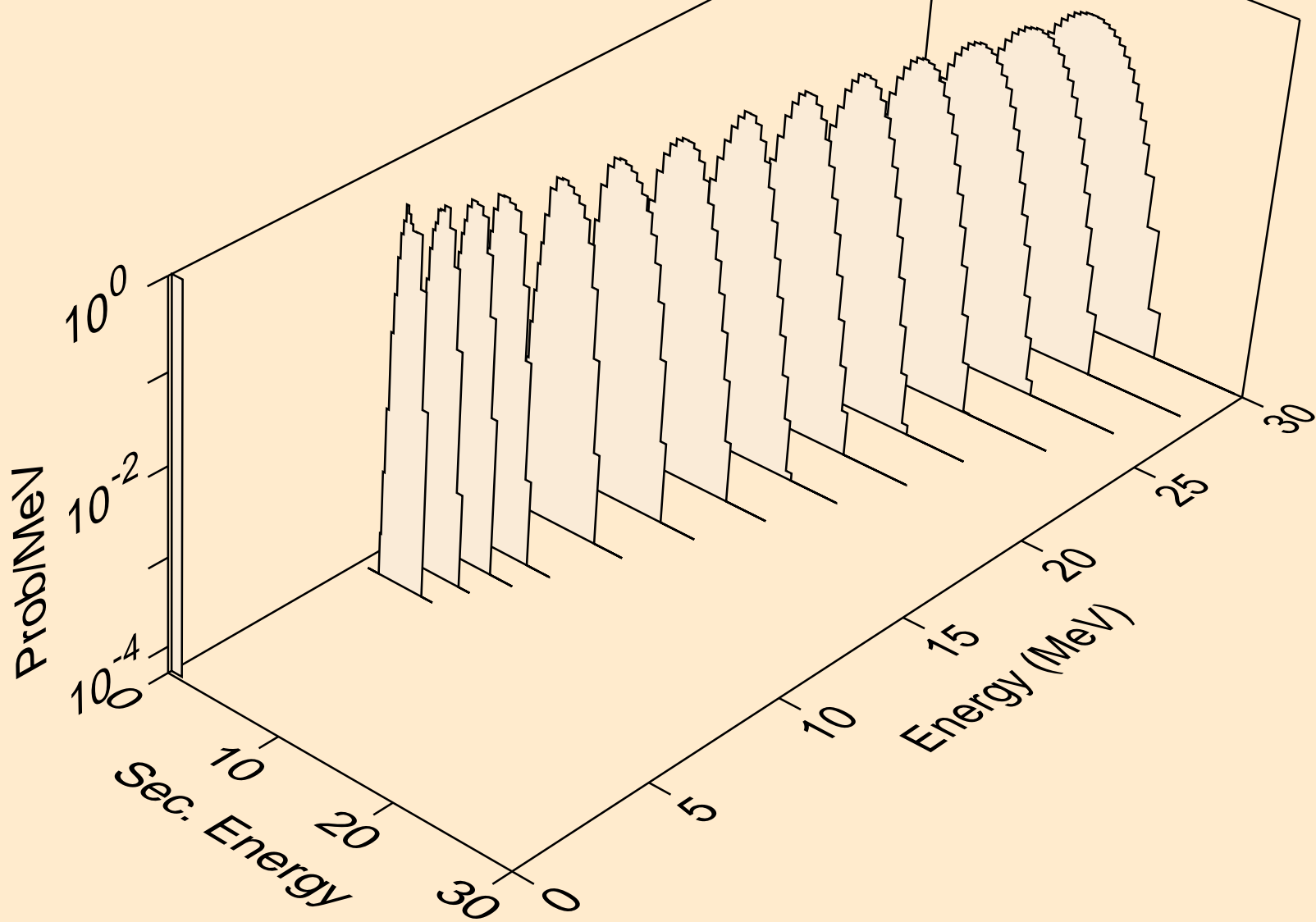

PU233 DEUTERON ACER TENDL-2024 LIBRARY; T=0.K
protons from (d,pa)

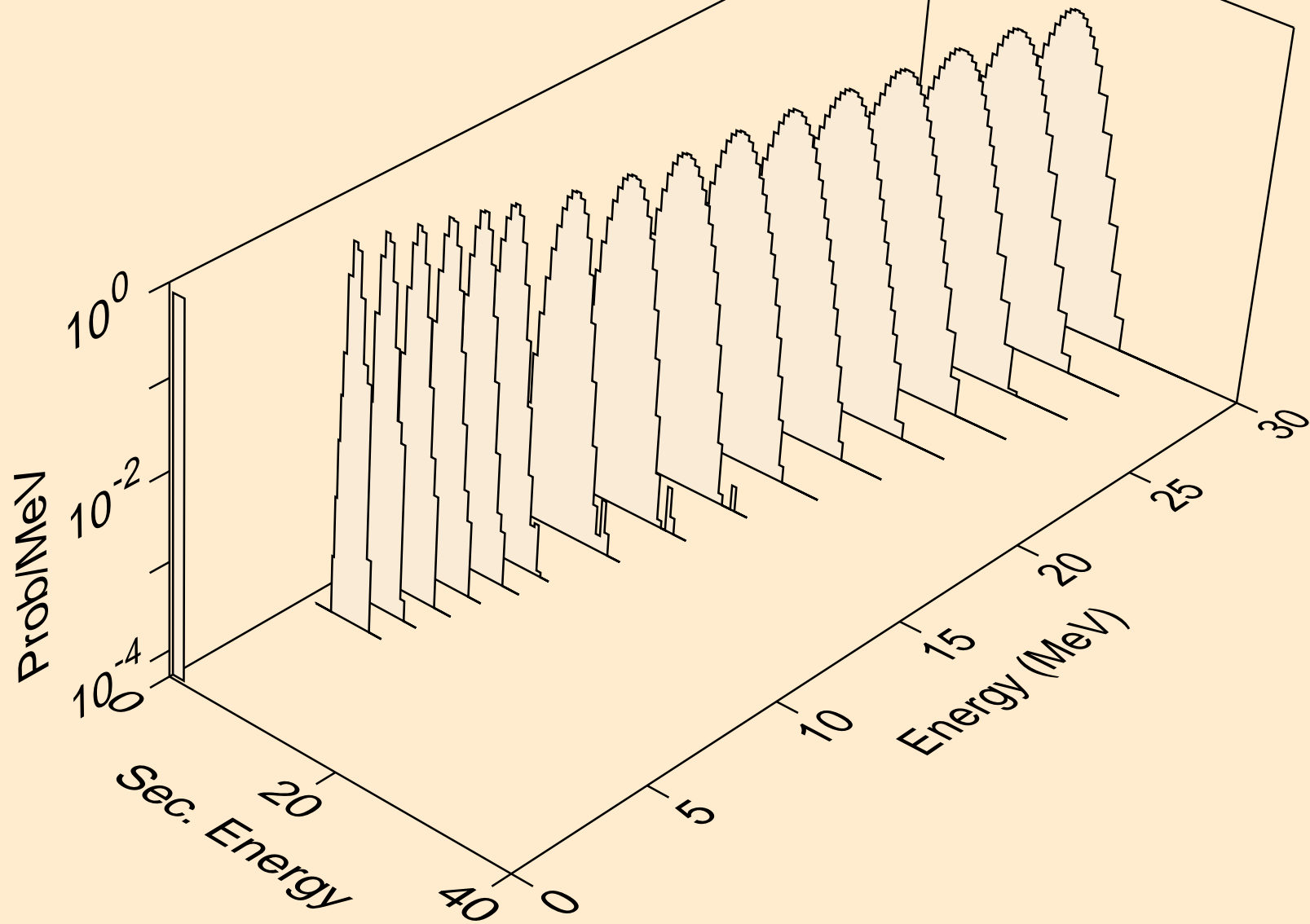

PU233 DEUTERON ACER TENDL-2024 LIBRARY; T=0.K
protons from (d,pd)

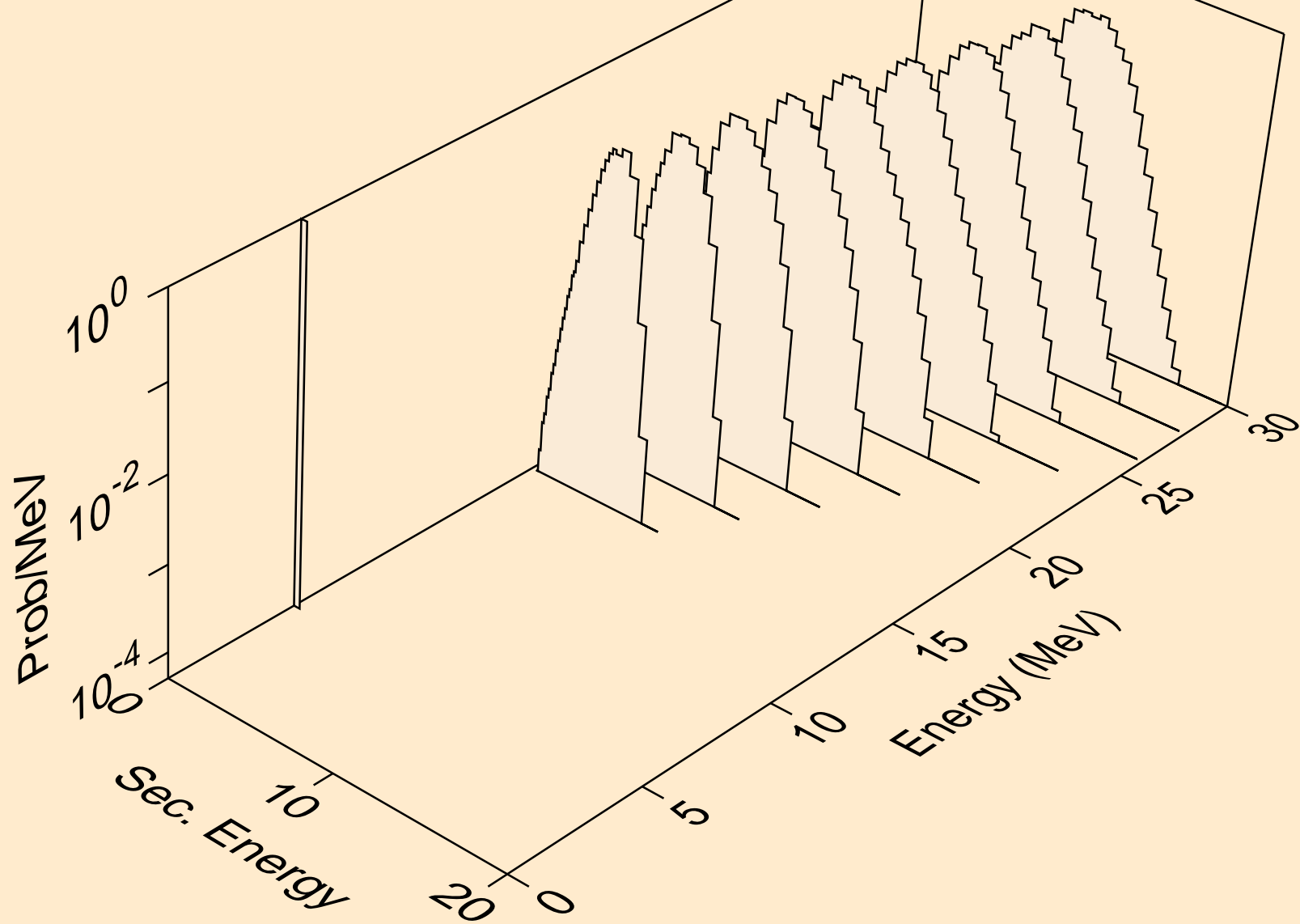

PU233 DEUTERON ACER TENDL-2024 LIBRARY; T=0.K
tritons from (d,x)

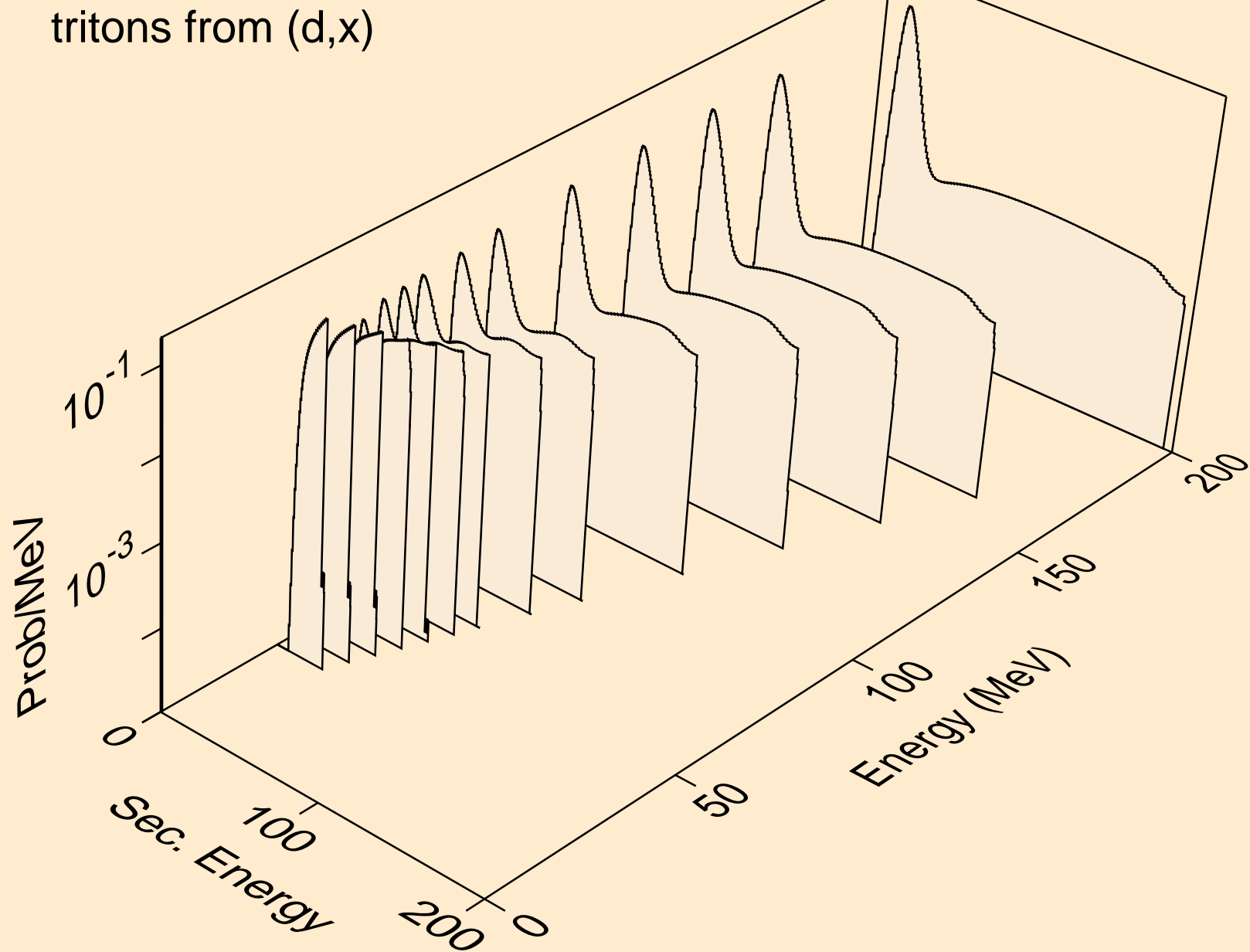

PU233 DEUTERON ACER TENDL-2024 LIBRARY; T=0.K
tritons from (d,n*)t

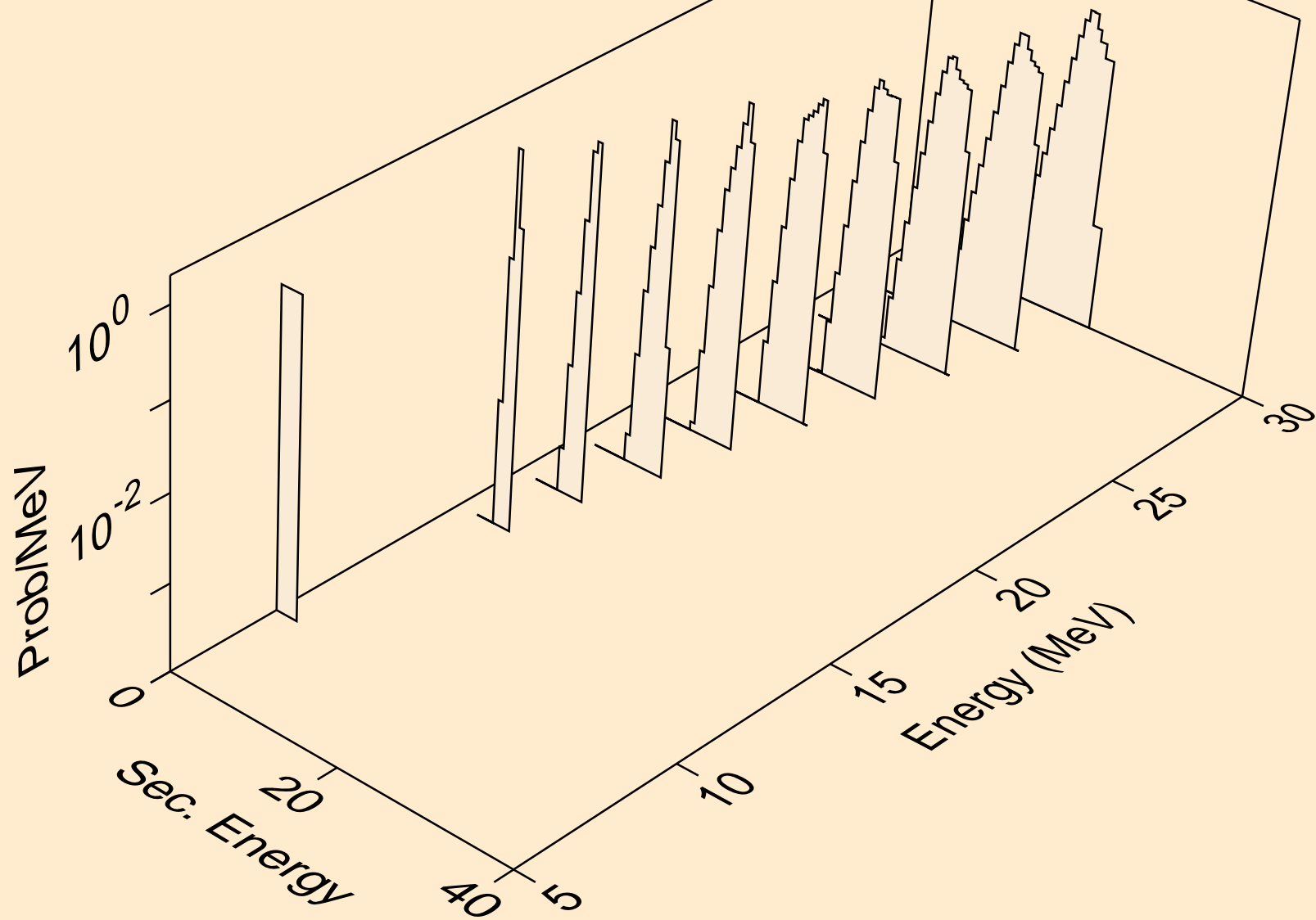

PU233 DEUTERON ACER TENDL-2024 LIBRARY; T=0.K
tritons from (d,t)

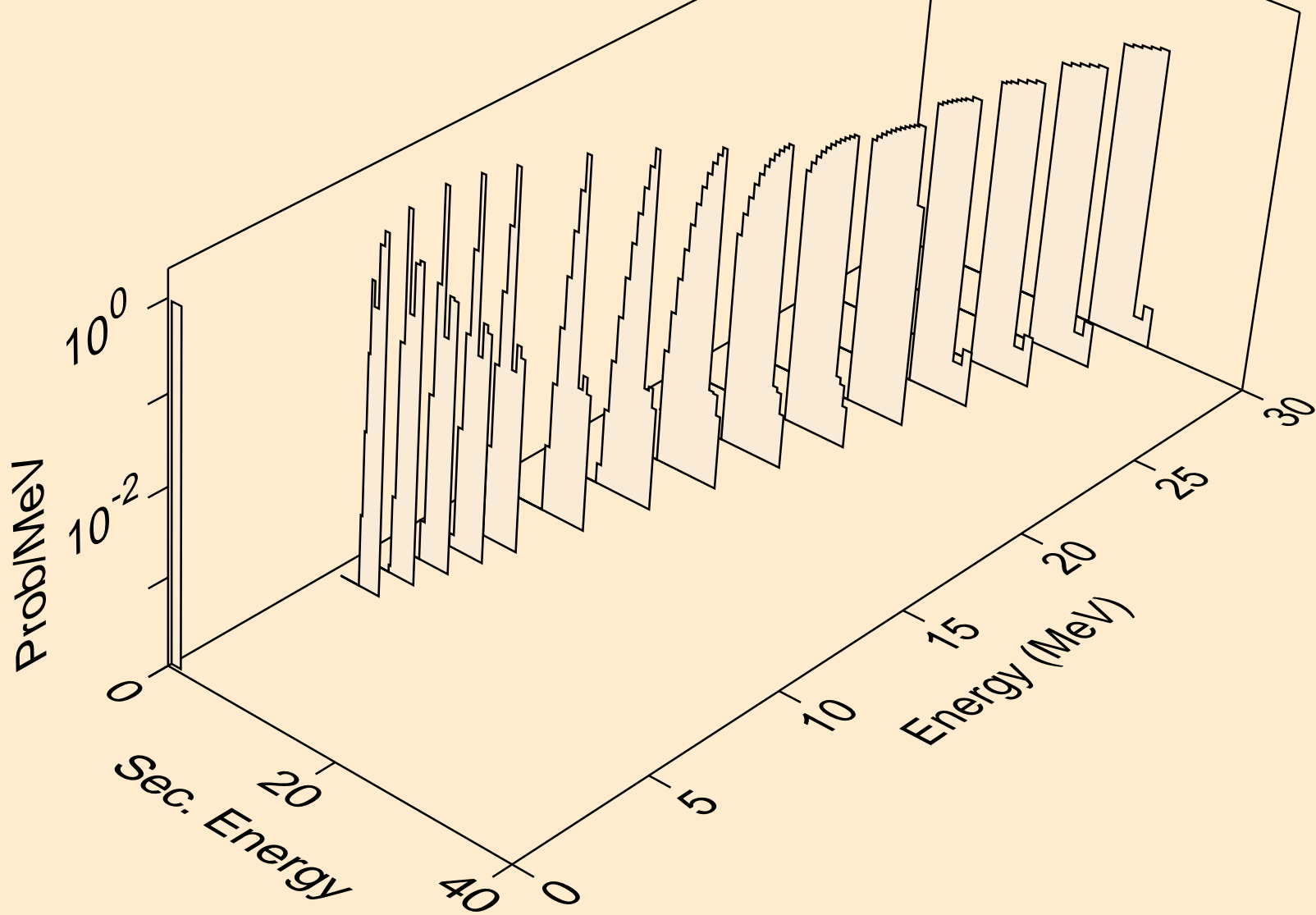

PU233 DEUTERON ACER TENDL-2024 LIBRARY; T=0.K
he3s from (d,x)

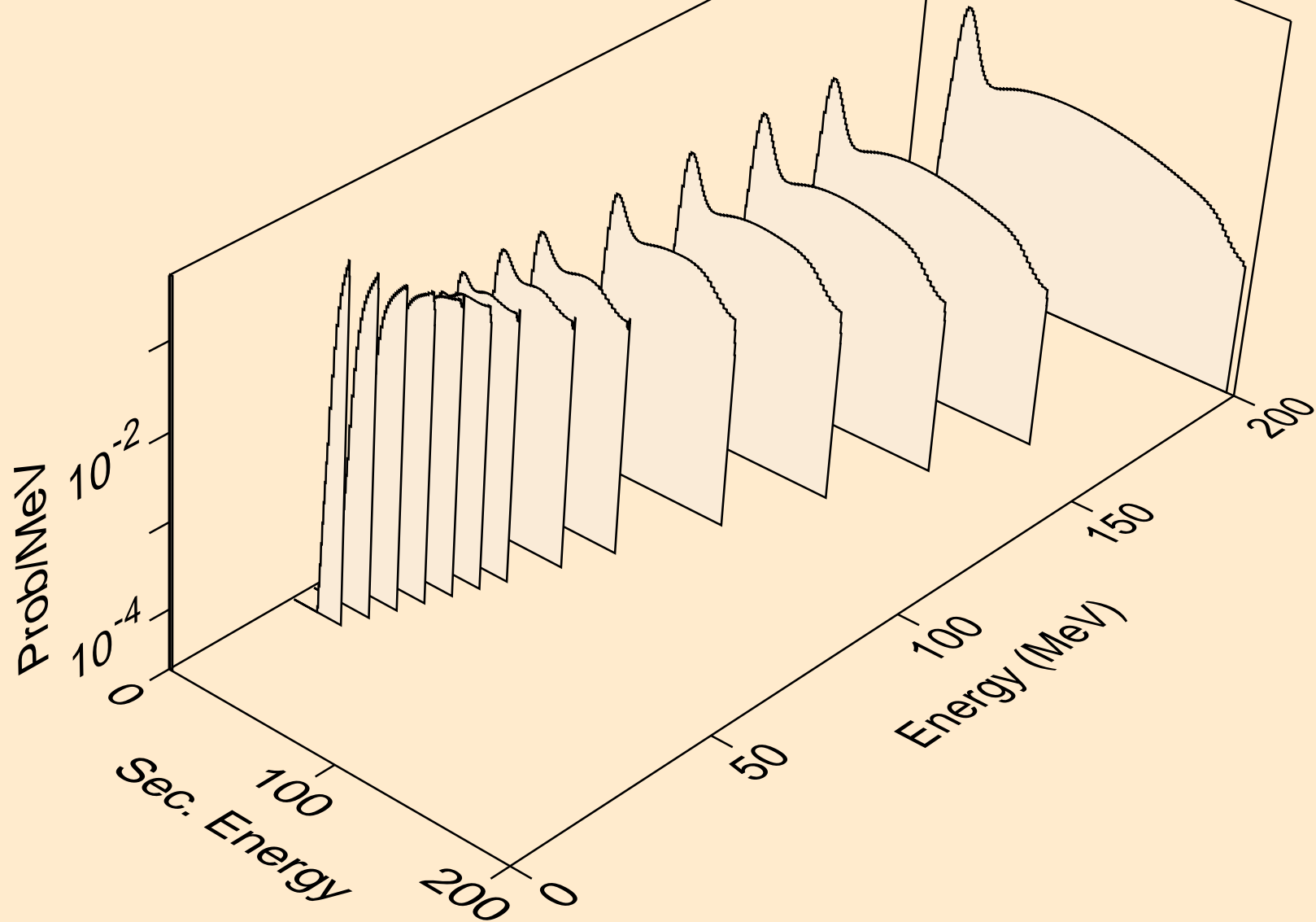

PU233 DEUTERON ACER TENDL-2024 LIBRARY; T=0.K
he3s from (d,n*)he3

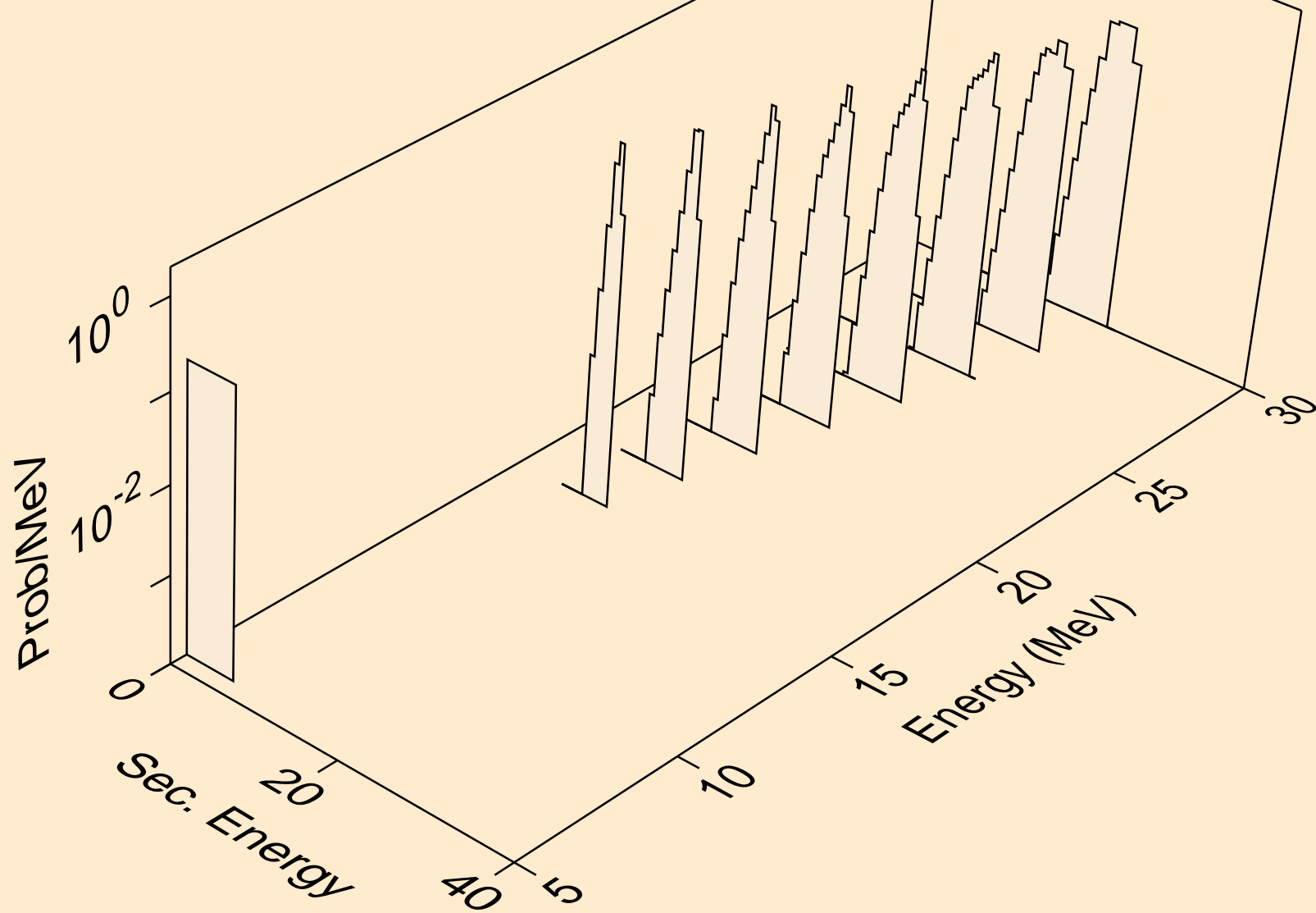

PU233 DEUTERON ACER TENDL-2024 LIBRARY; T=0.K
he3s from (d,he3)

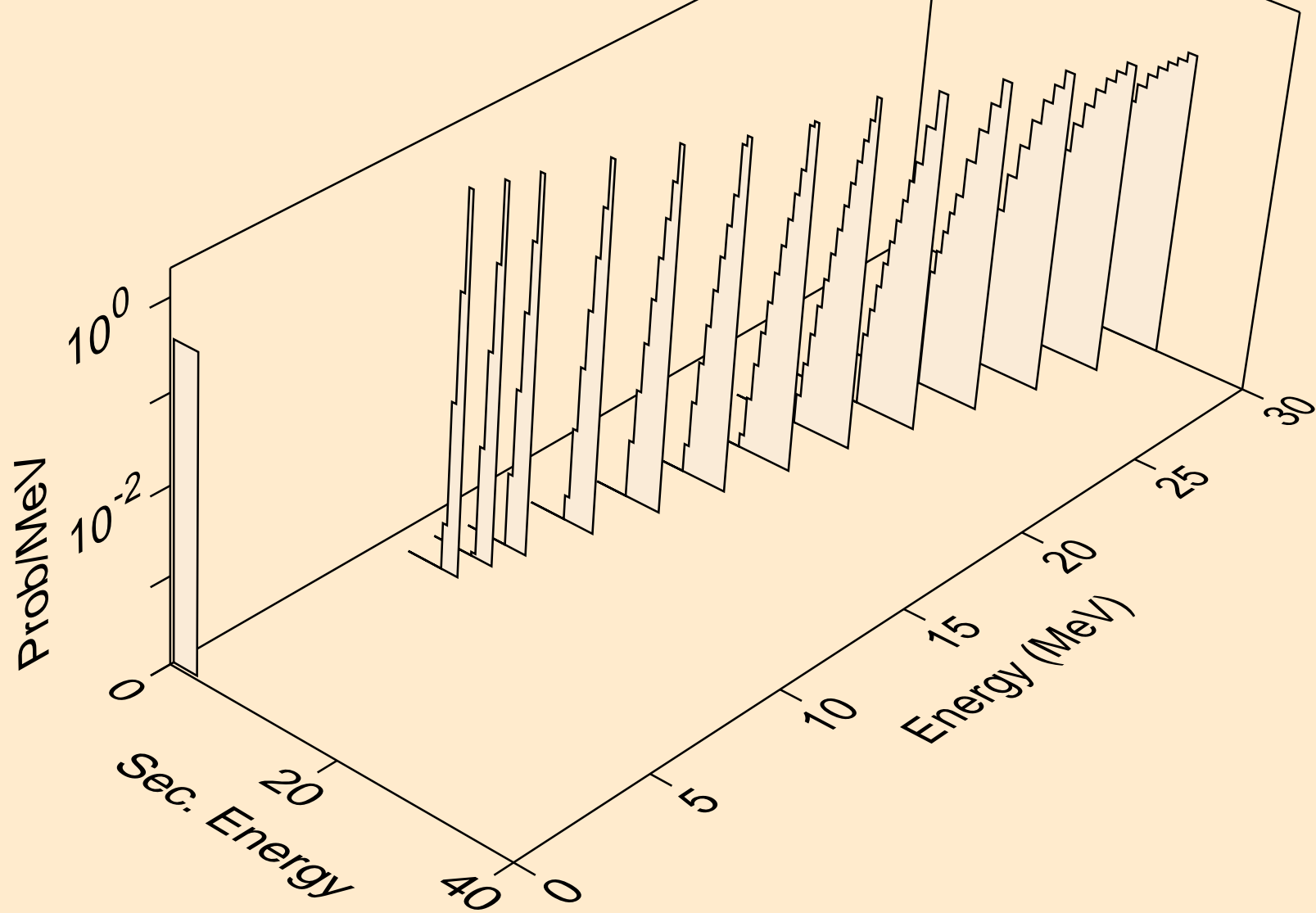

PU233 DEUTERON ACER TENDL-2024 LIBRARY; T=0.K
alphas from (d,x)

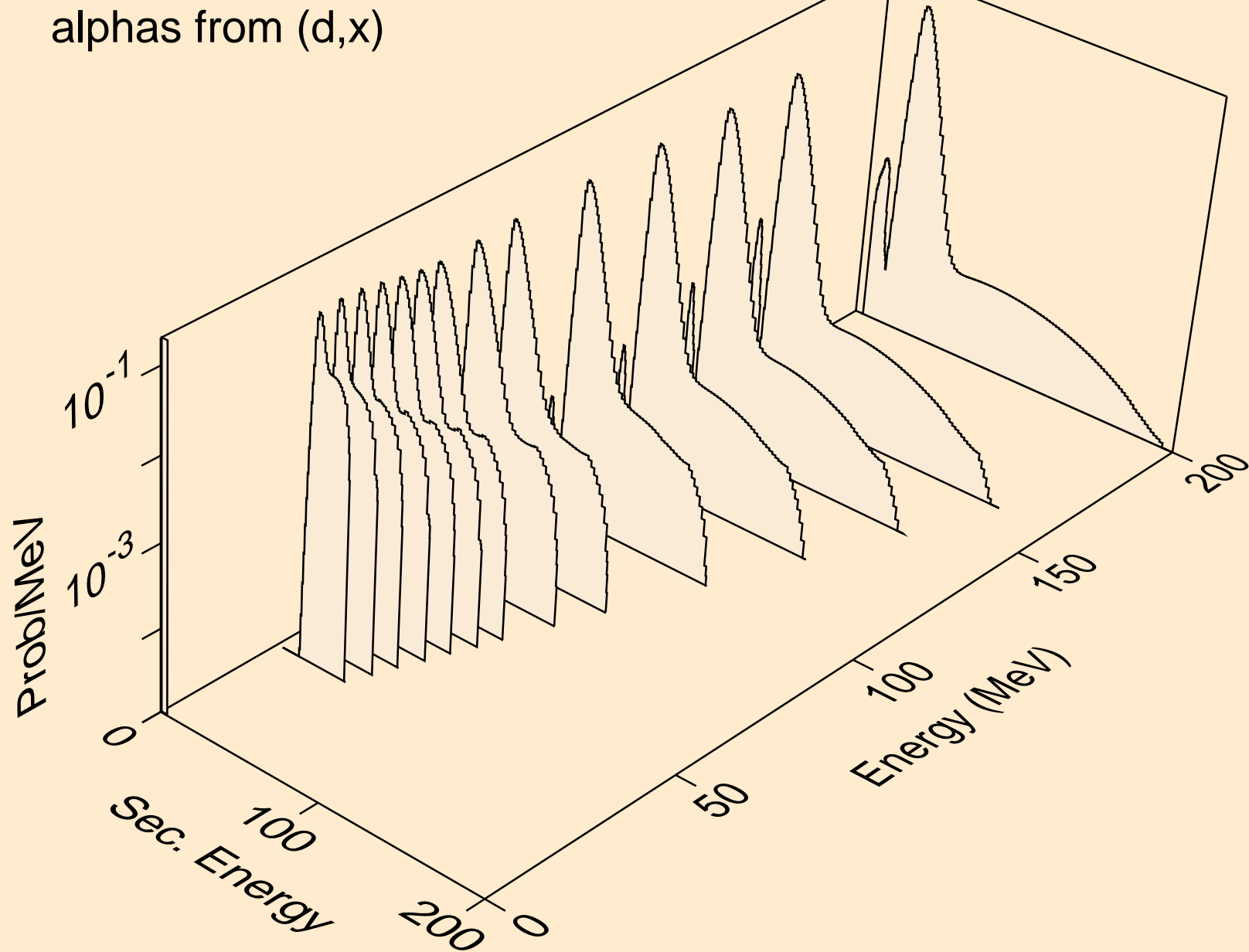

PU233 DEUTERON ACER TENDL-2024 LIBRARY; T=0.K
alphas from (d,n*)a

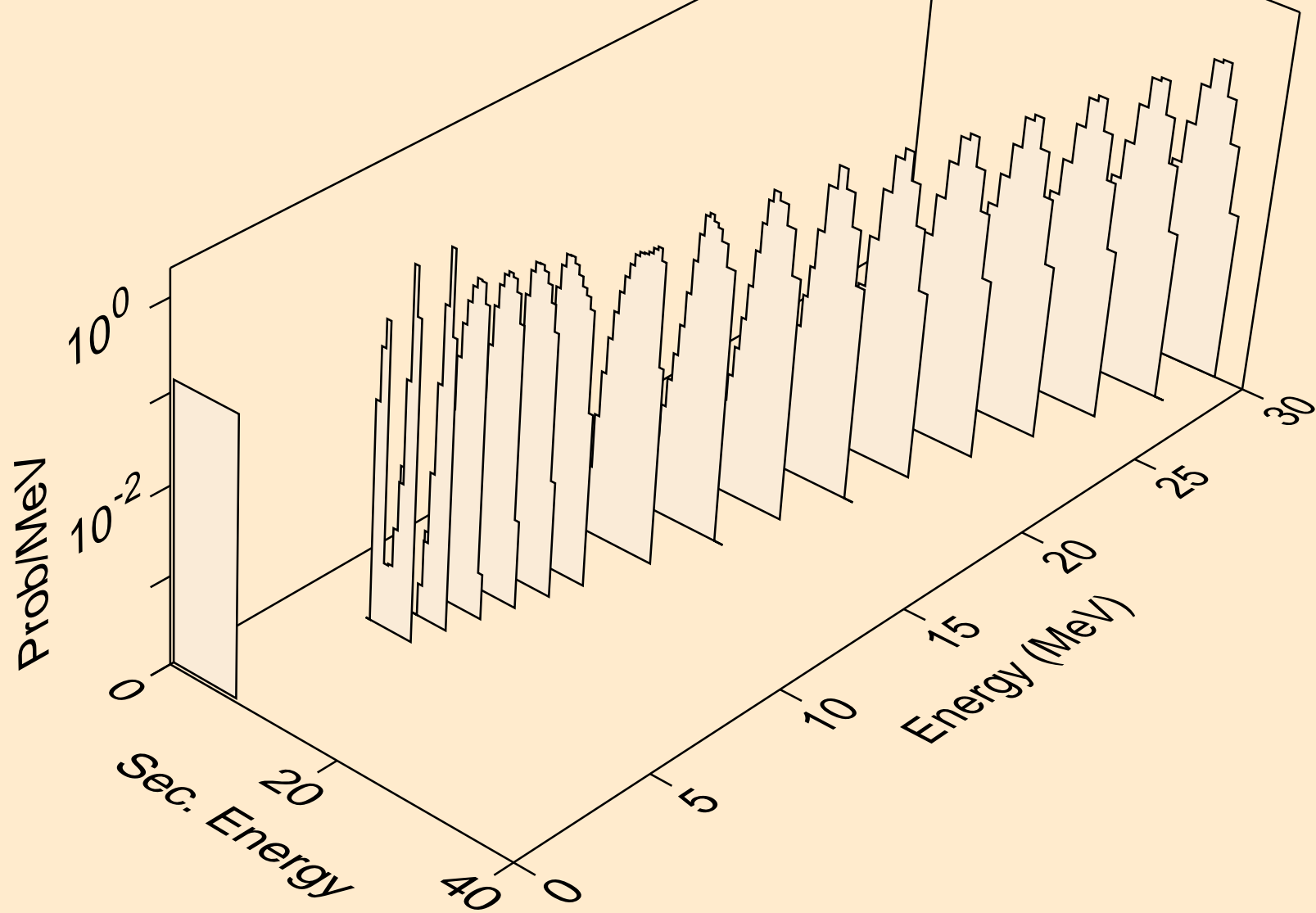

PU233 DEUTERON ACER TENDL-2024 LIBRARY; T=0.K
alphas from (d,2n)a

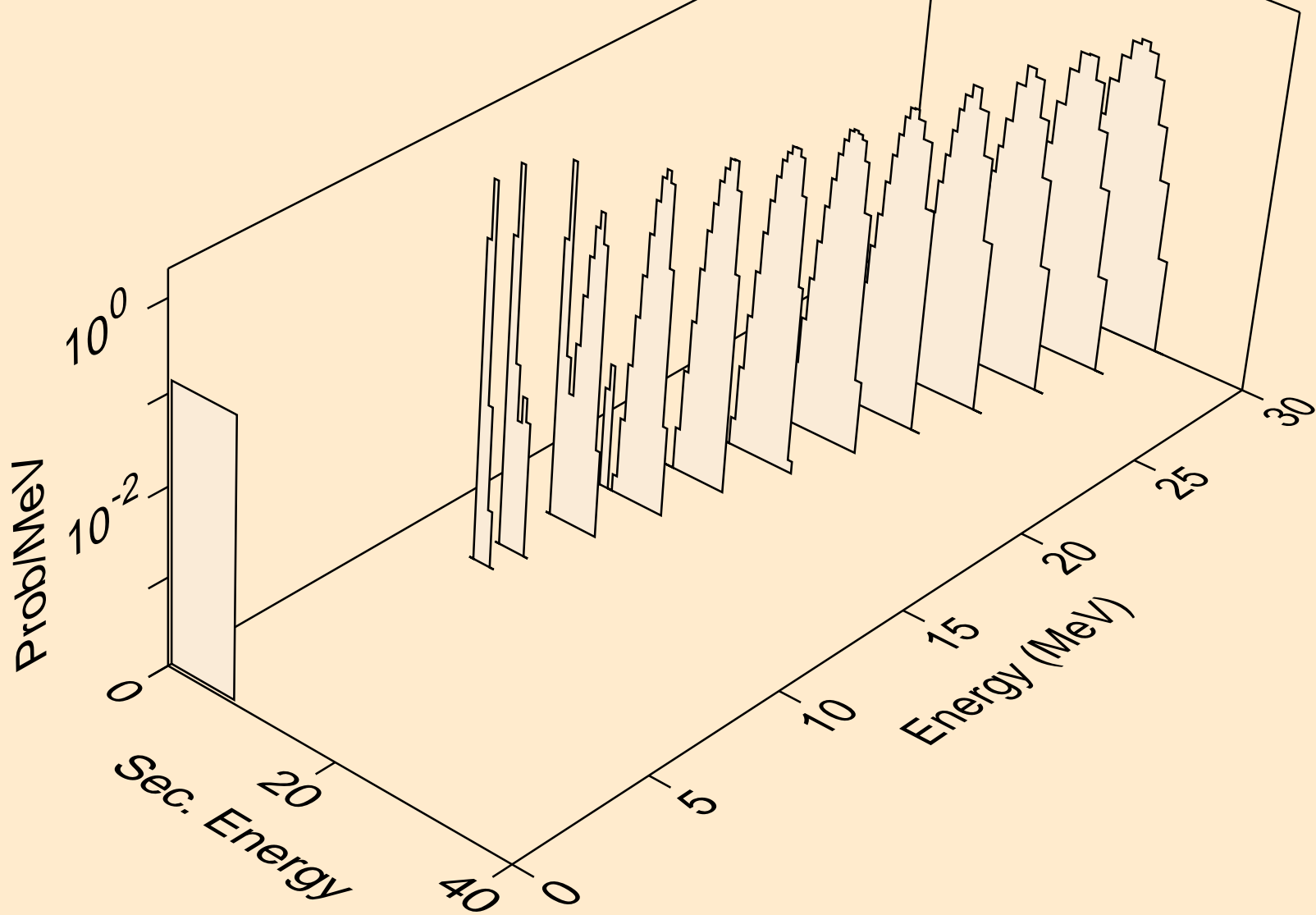

PU233 DEUTERON ACER TENDL-2024 LIBRARY; T=0.K
alphas from (d,3n)a

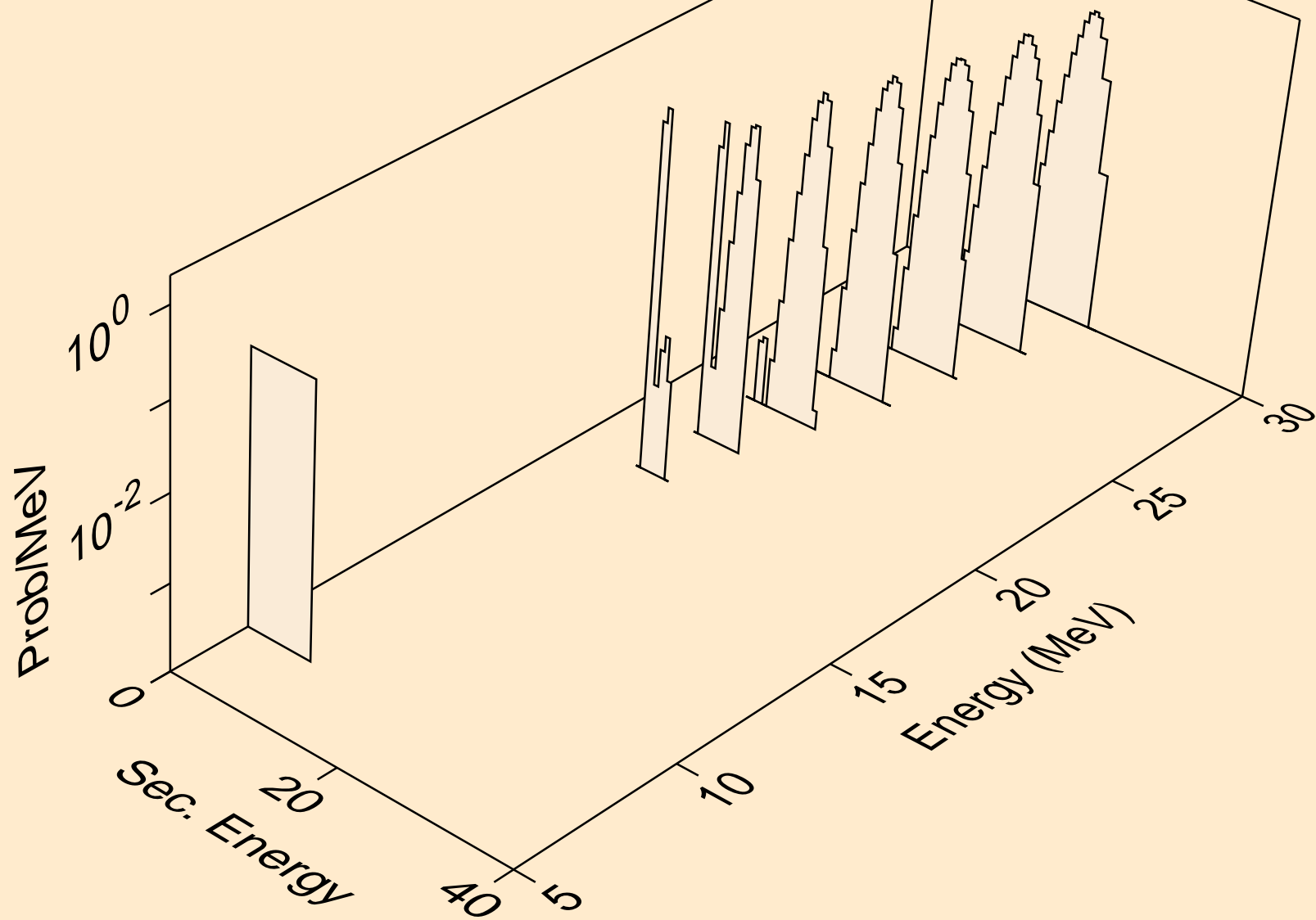

PU233 DEUTERON ACER TENDL-2024 LIBRARY; T=0.K
alphas from (d,n*)2a

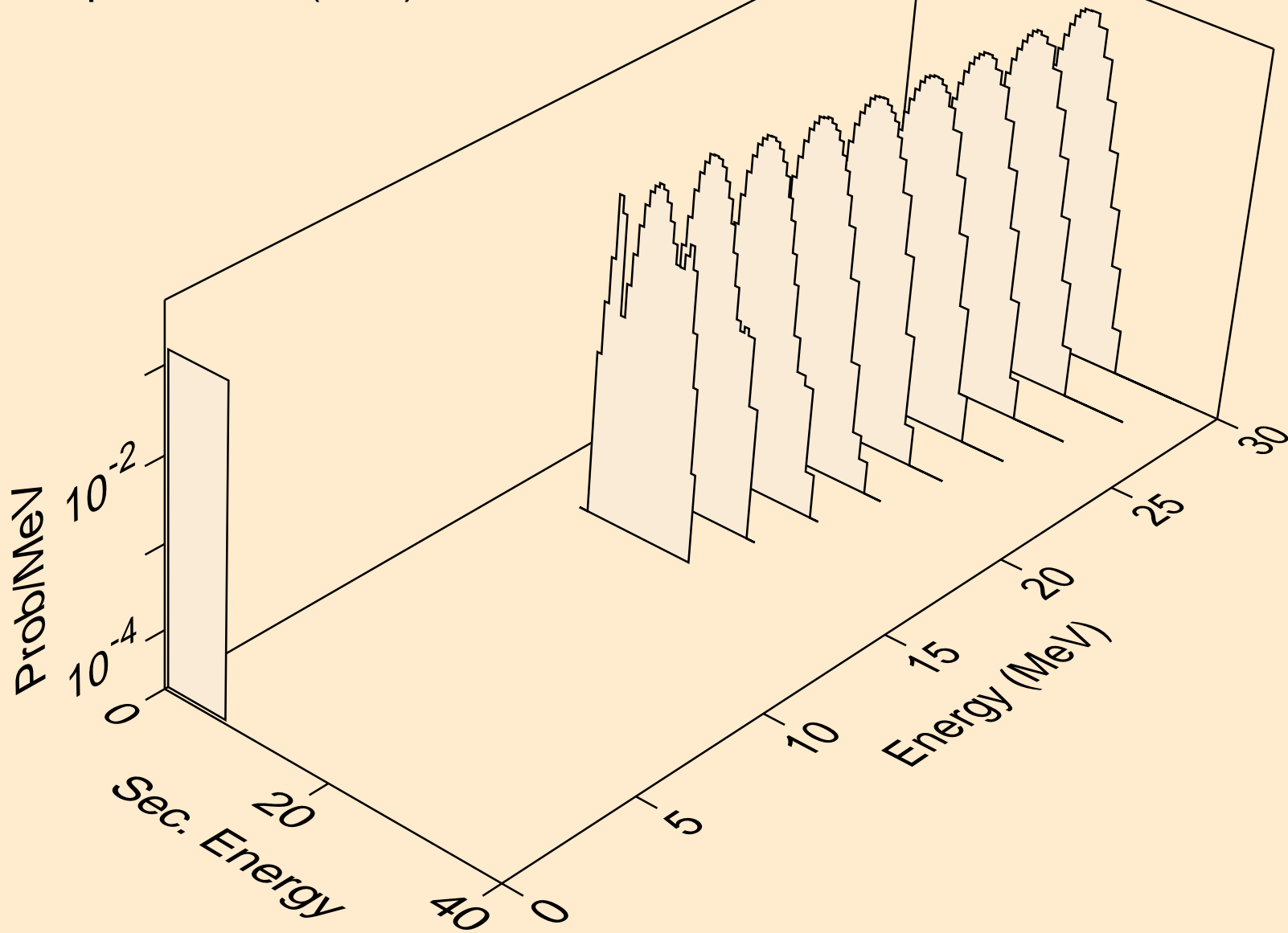

PU233 DEUTERON ACER TENDL-2024 LIBRARY; T=0.K
alphas from (d,npa)

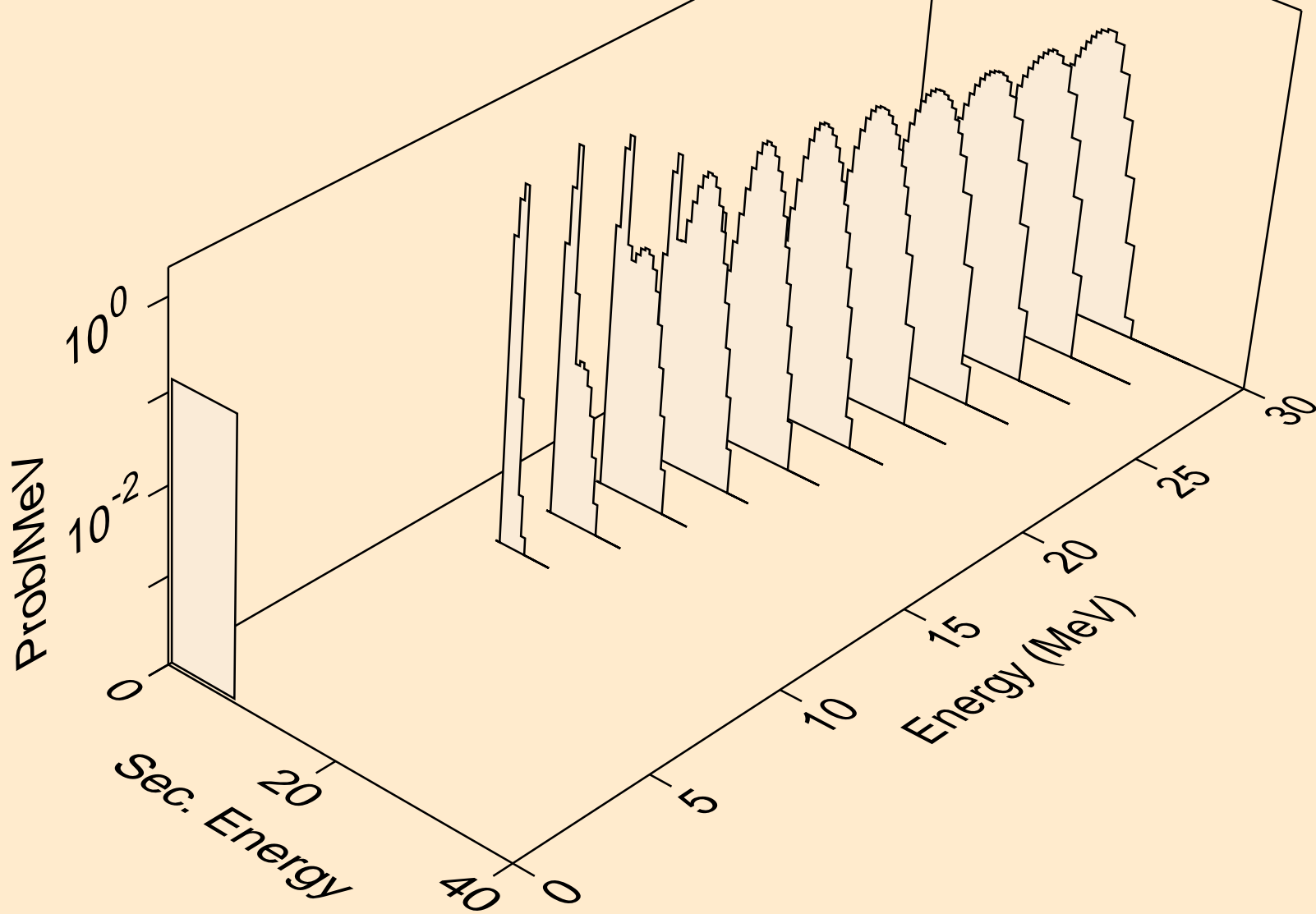

PU233 DEUTERON ACER TENDL-2024 LIBRARY; T=0.K
alphas from (d,a)

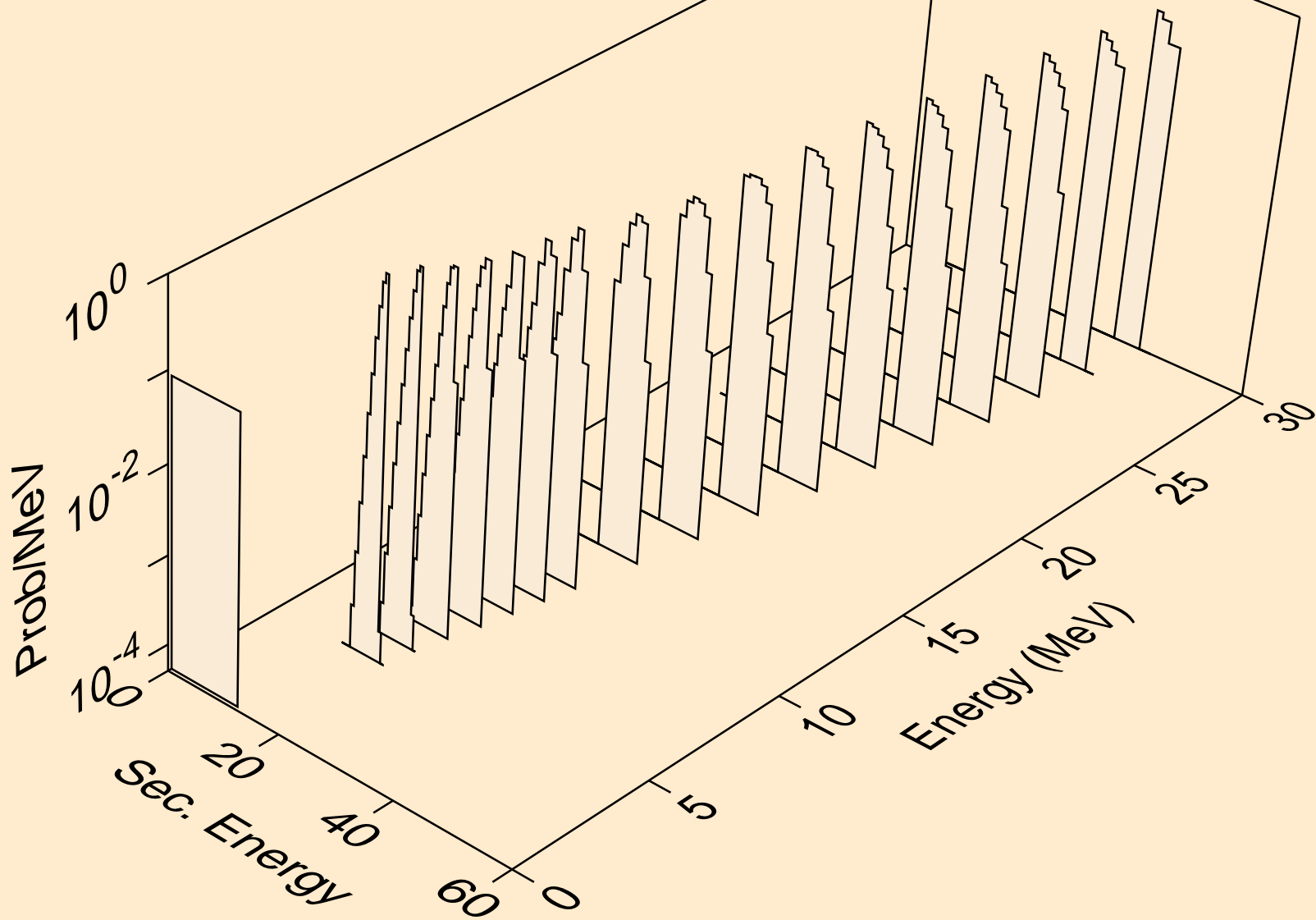

PU233 DEUTERON ACER TENDL-2024 LIBRARY; T=0.K
alphas from (d,2a)

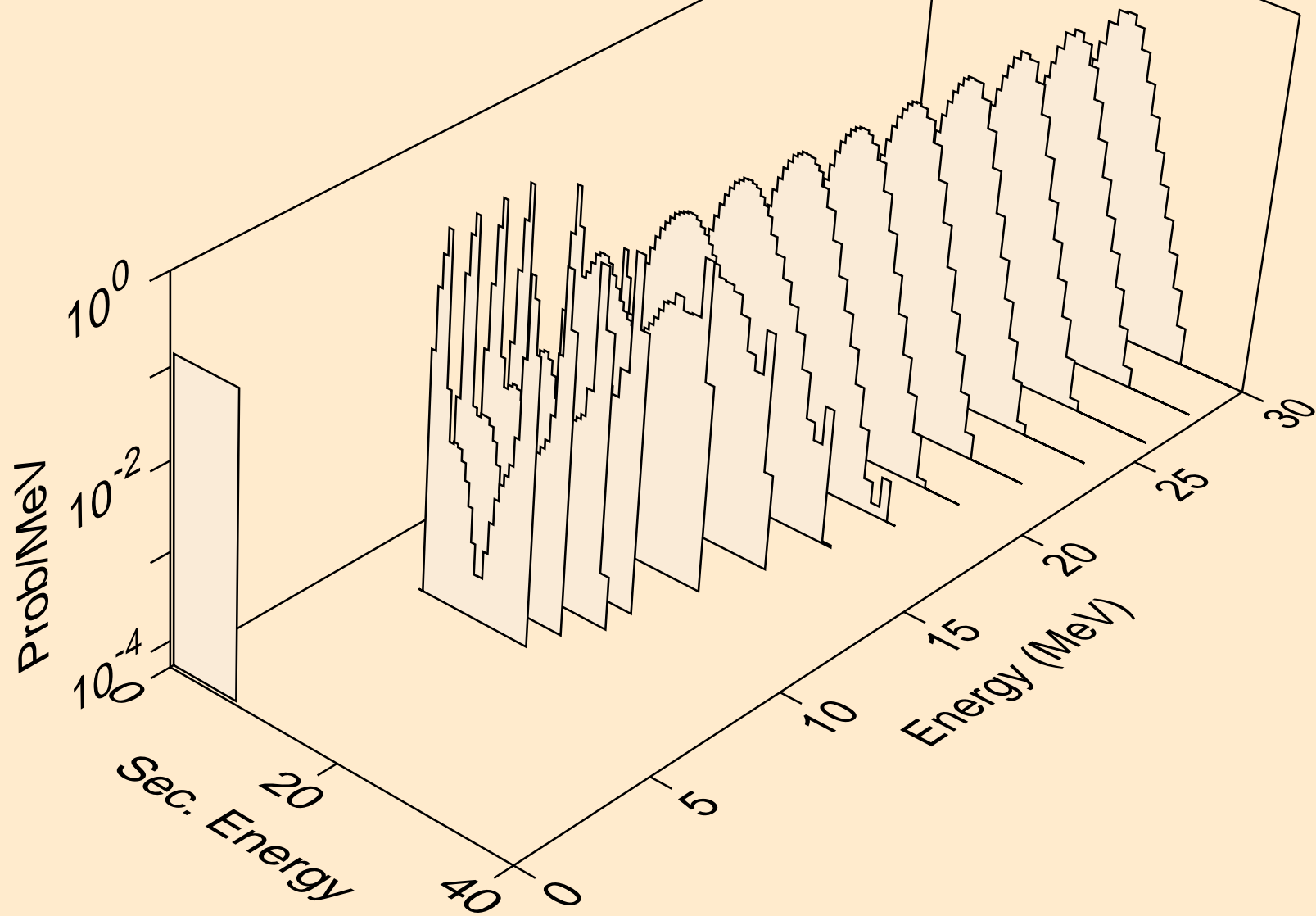

PU233 DEUTERON ACER TENDL-2024 LIBRARY; T=0.K
alphas from (d,pa)

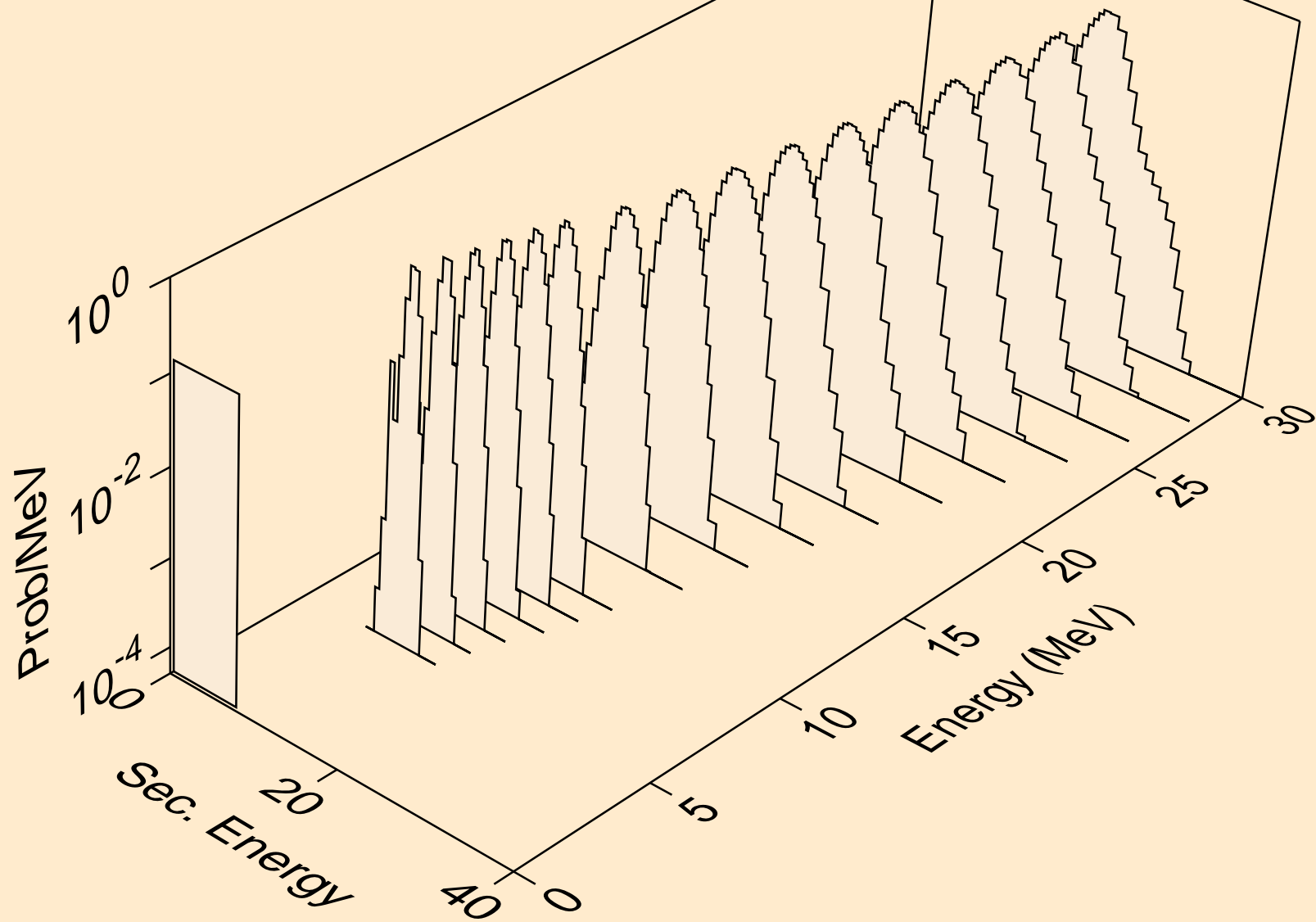

PU233 DEUTERON ACER TENDL-2024 LIBRARY; T=0.K
alphas from (d,da)

