

F019 PHOTON ACER TENDL-2024 LIBRARY; T=0.K
Principal cross sections

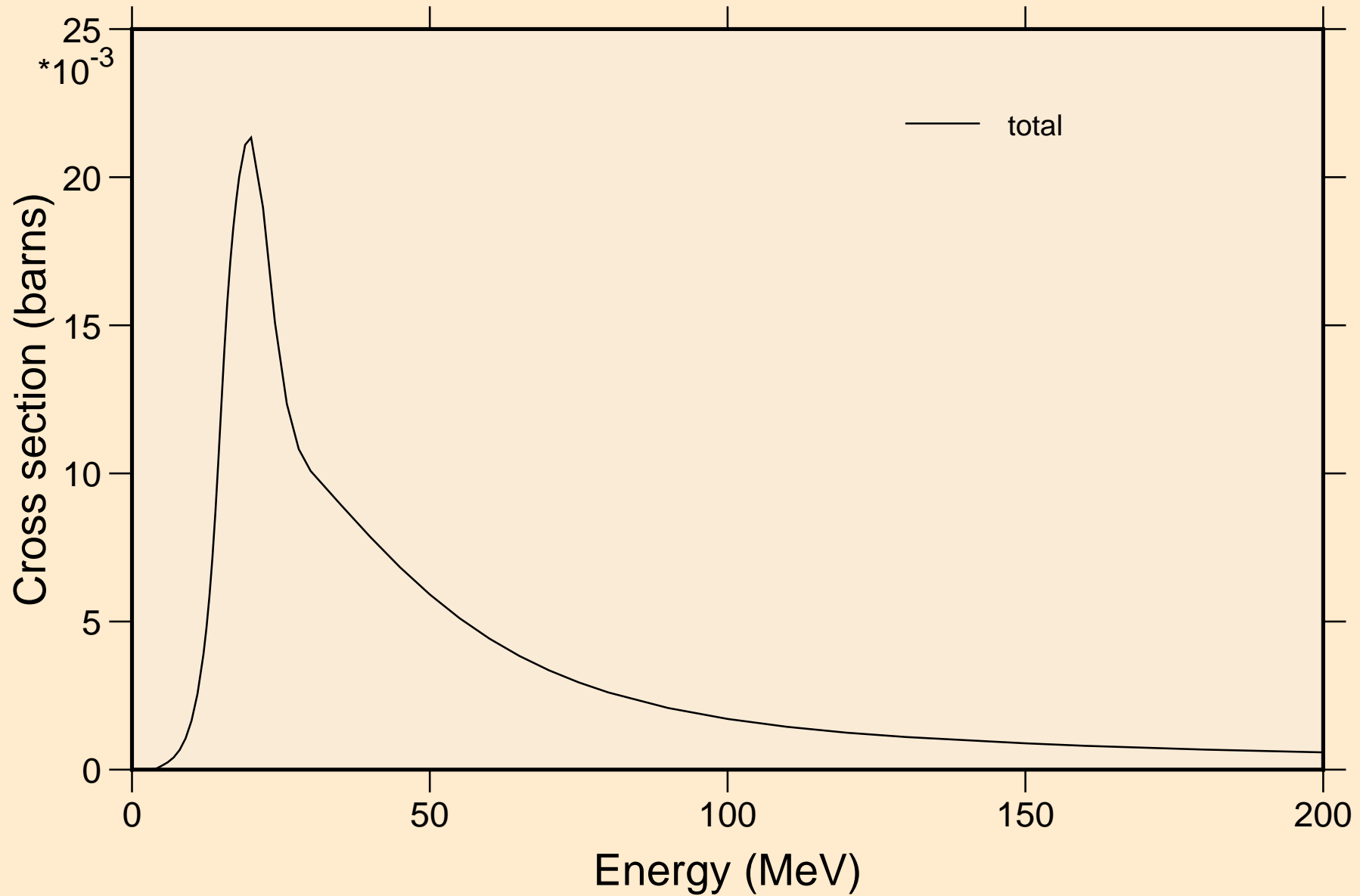

F019 PHOTON ACER TENDL-2024 LIBRARY; T=0.K

Heating

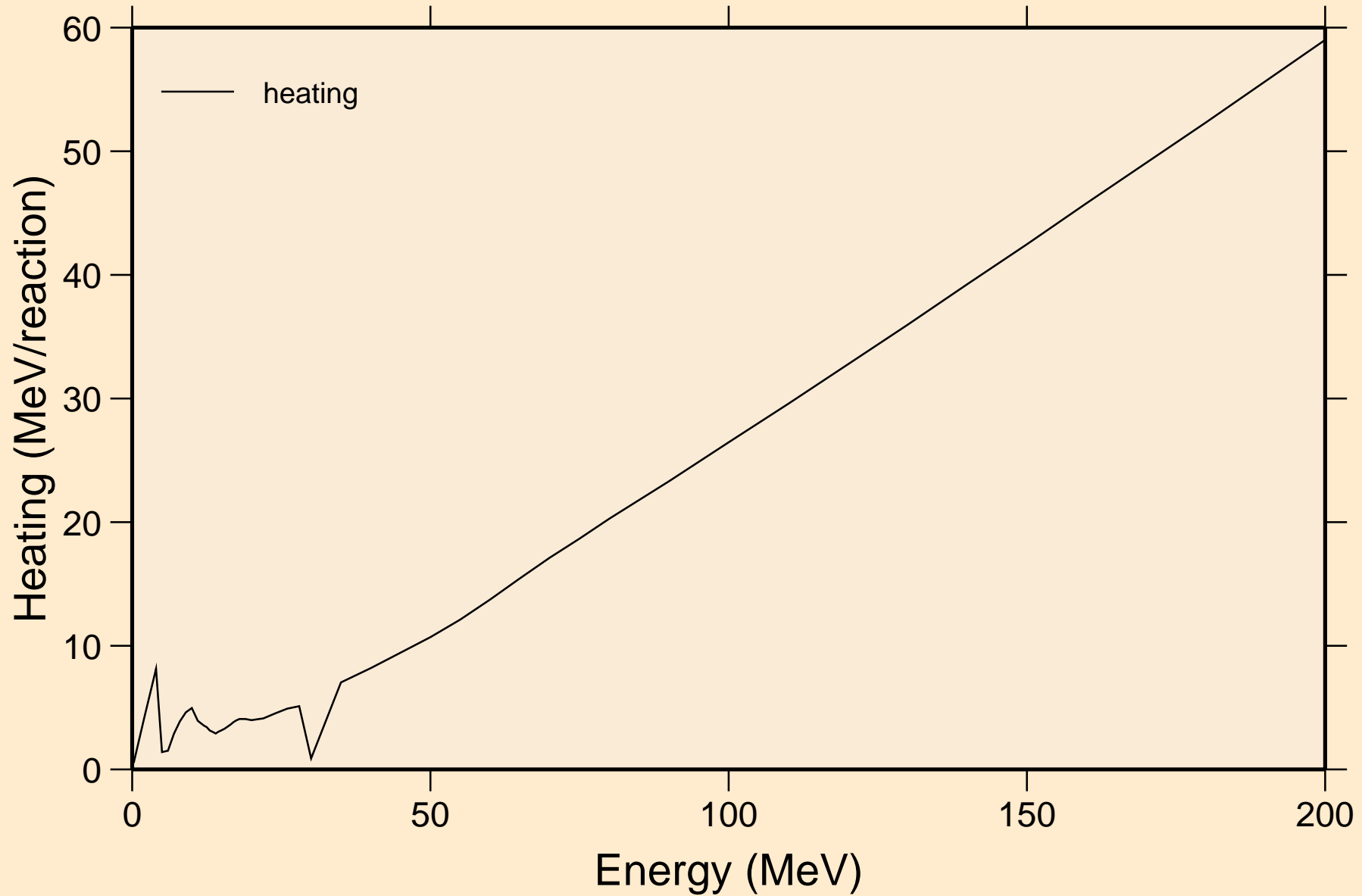

F019 PHOTON ACER TENDL-2024 LIBRARY; T=0.K

Particle heating contributions

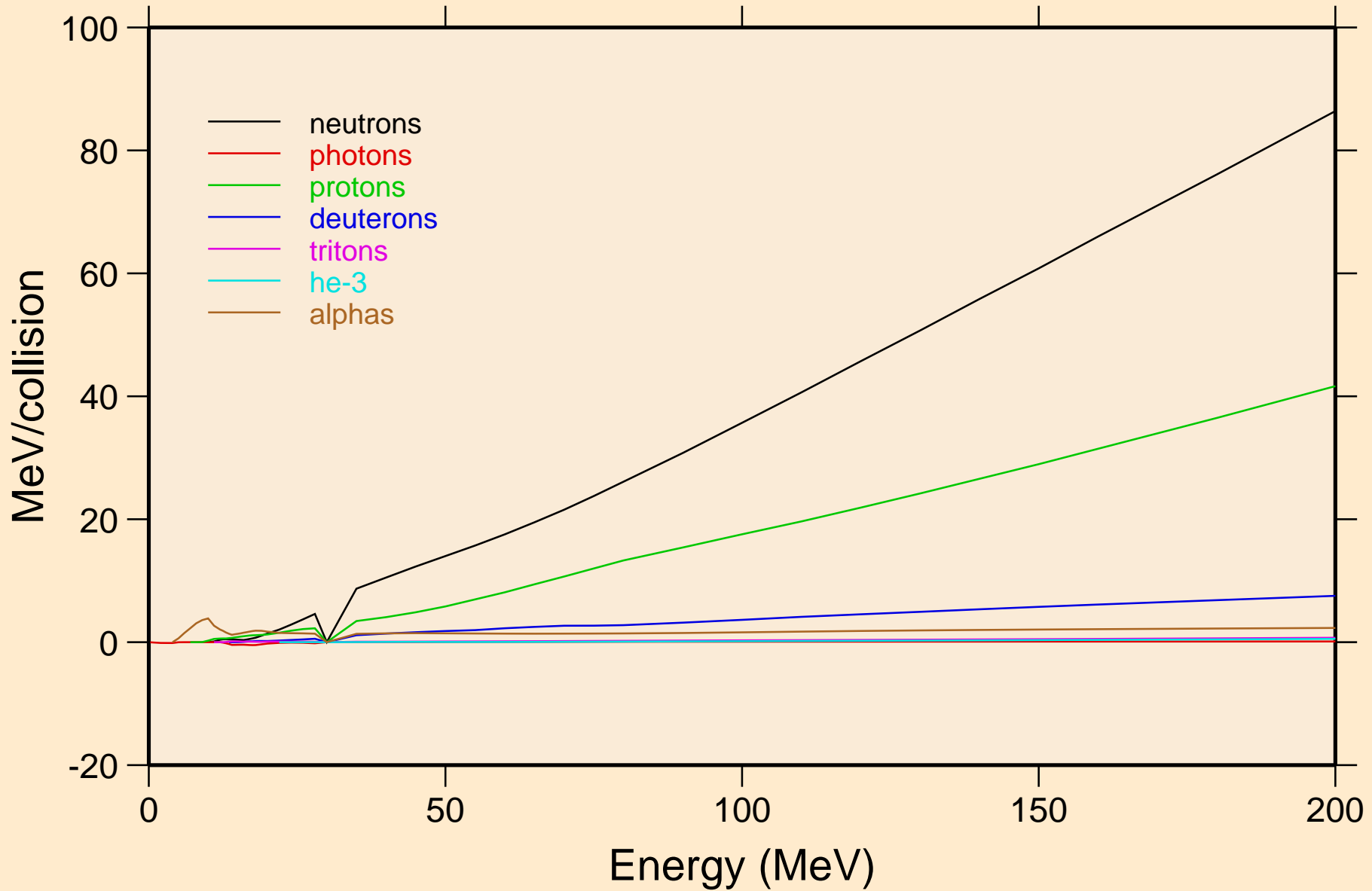

F019 PHOTON ACER TENDL-2024 LIBRARY; T=0.K
Particle production cross sections

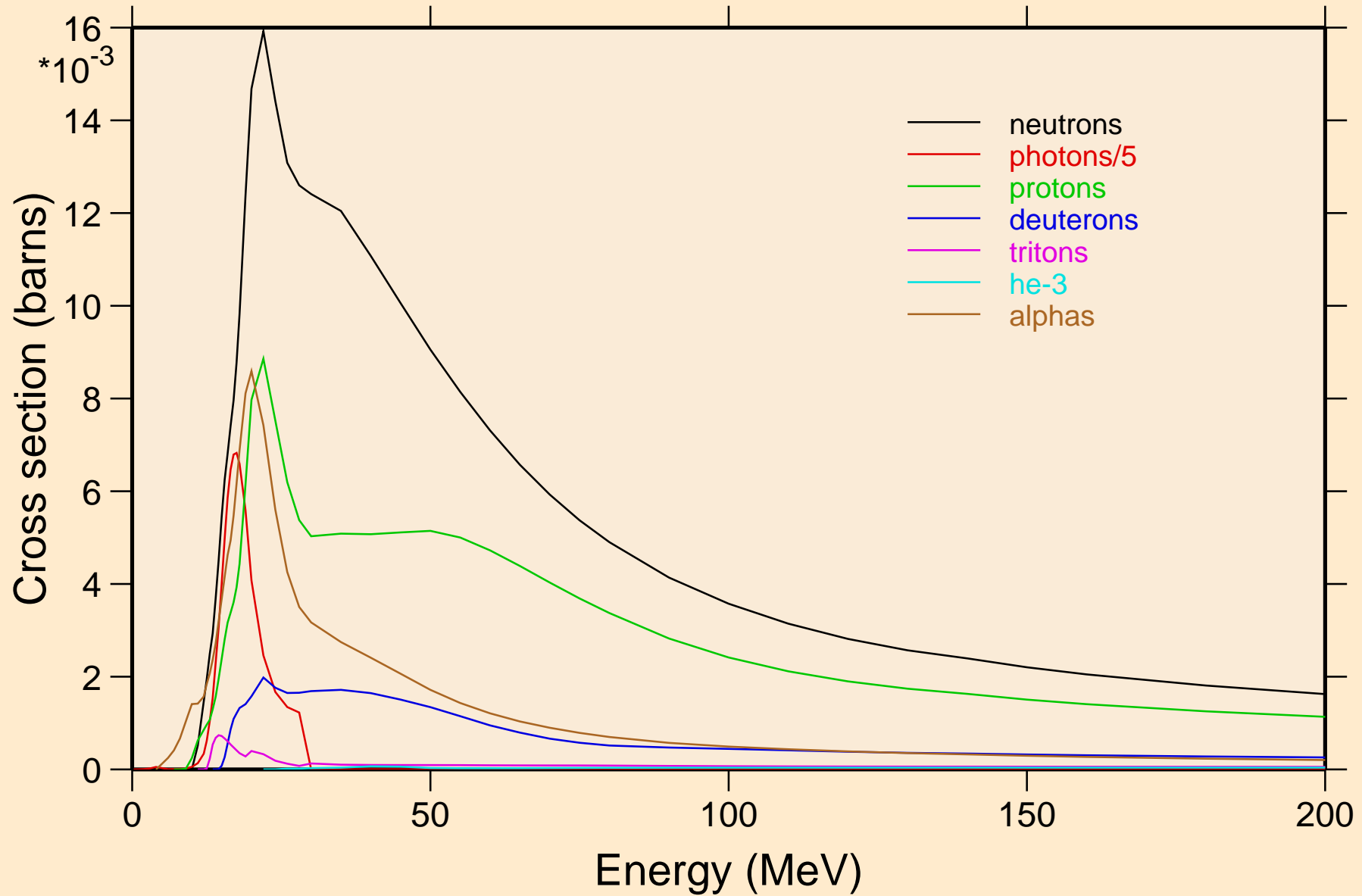

F019 PHOTON ACER TENDL-2024 LIBRARY; T=0.K
neutrons from (g,x)

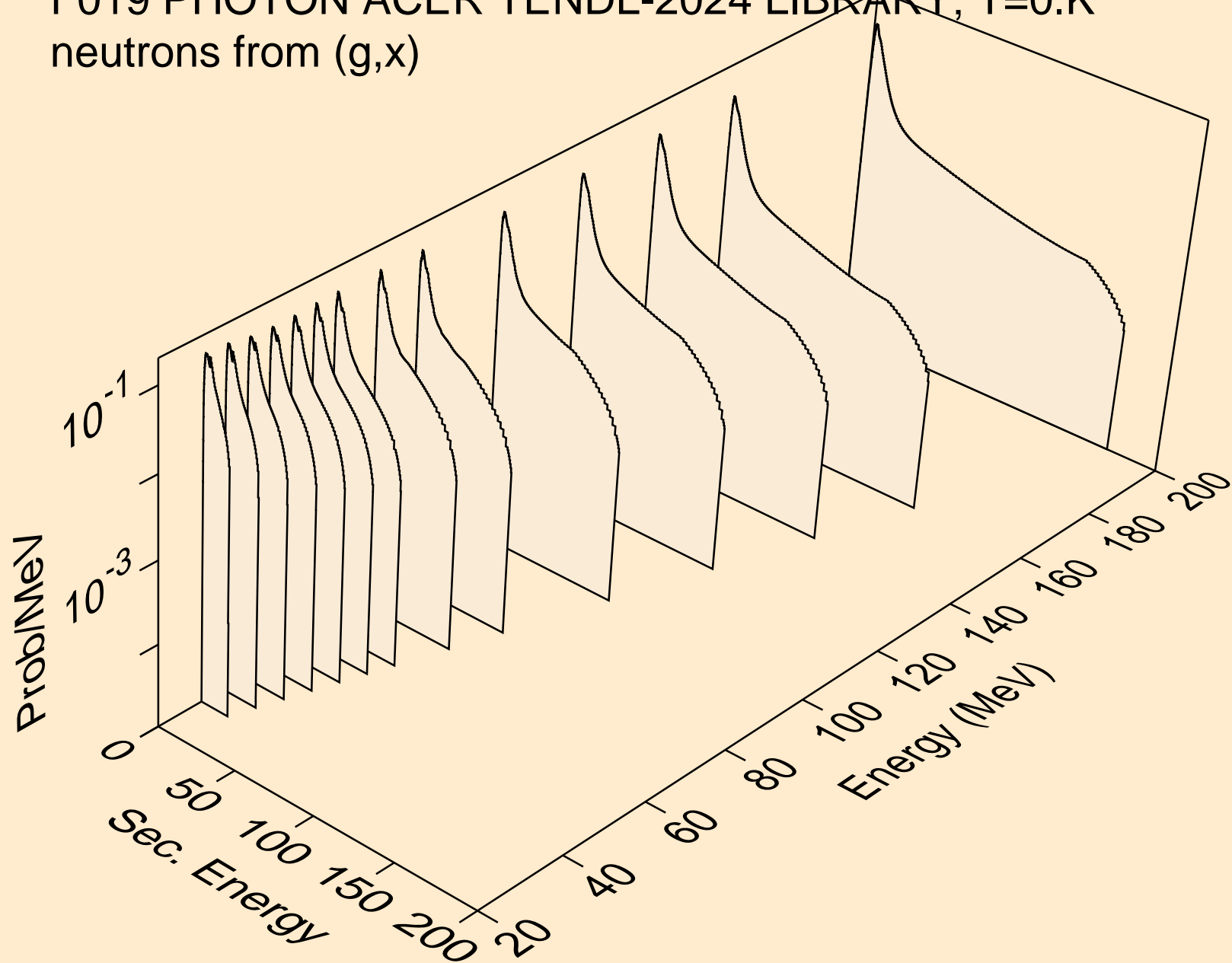

F019 PHOTON ACER TENDL-2024 LIBRARY; T=0.K
neutrons from (g,2n)

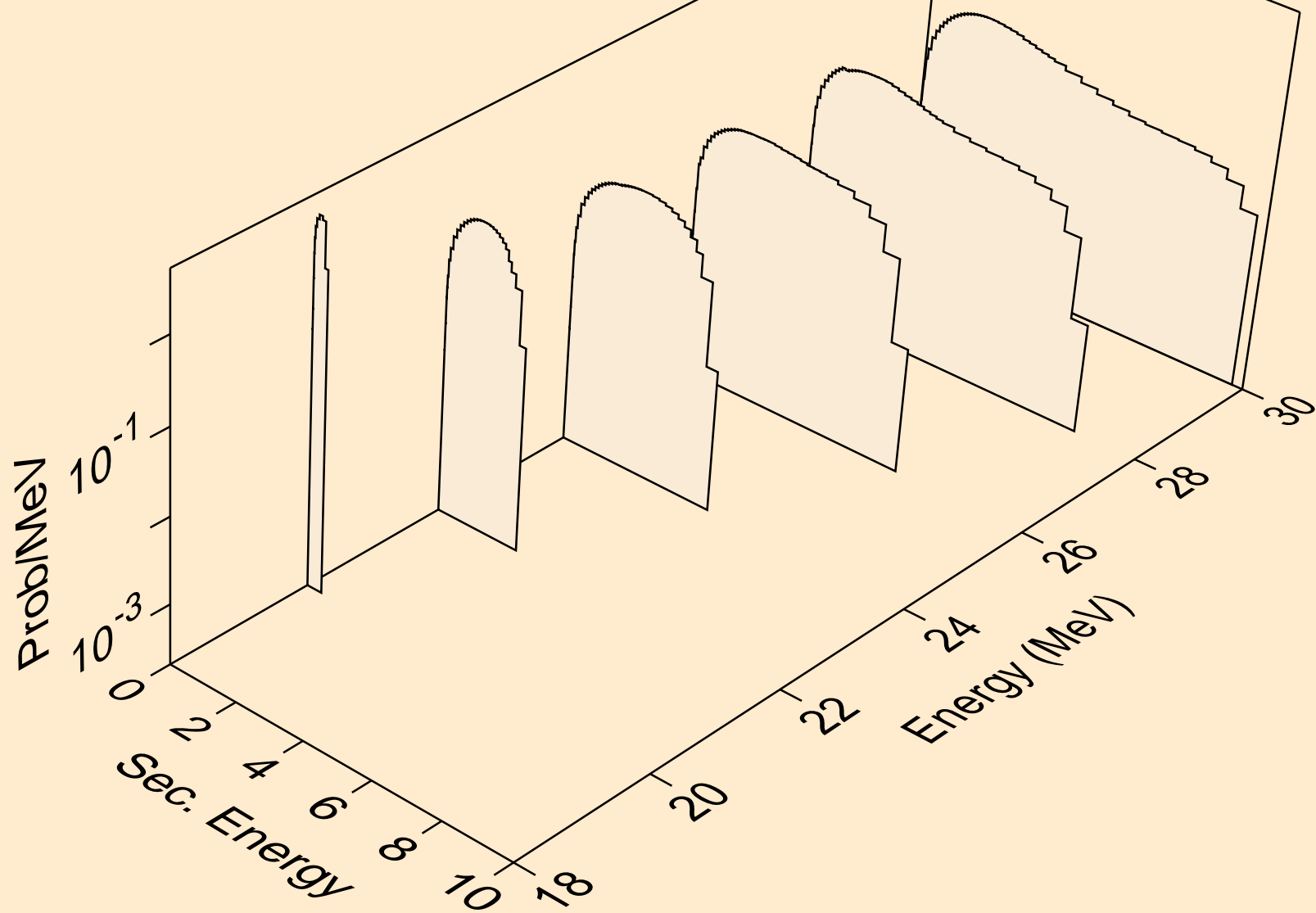

F019 PHOTON ACER TENDL-2024 LIBRARY; T=0.K
neutrons from (g,n*)a

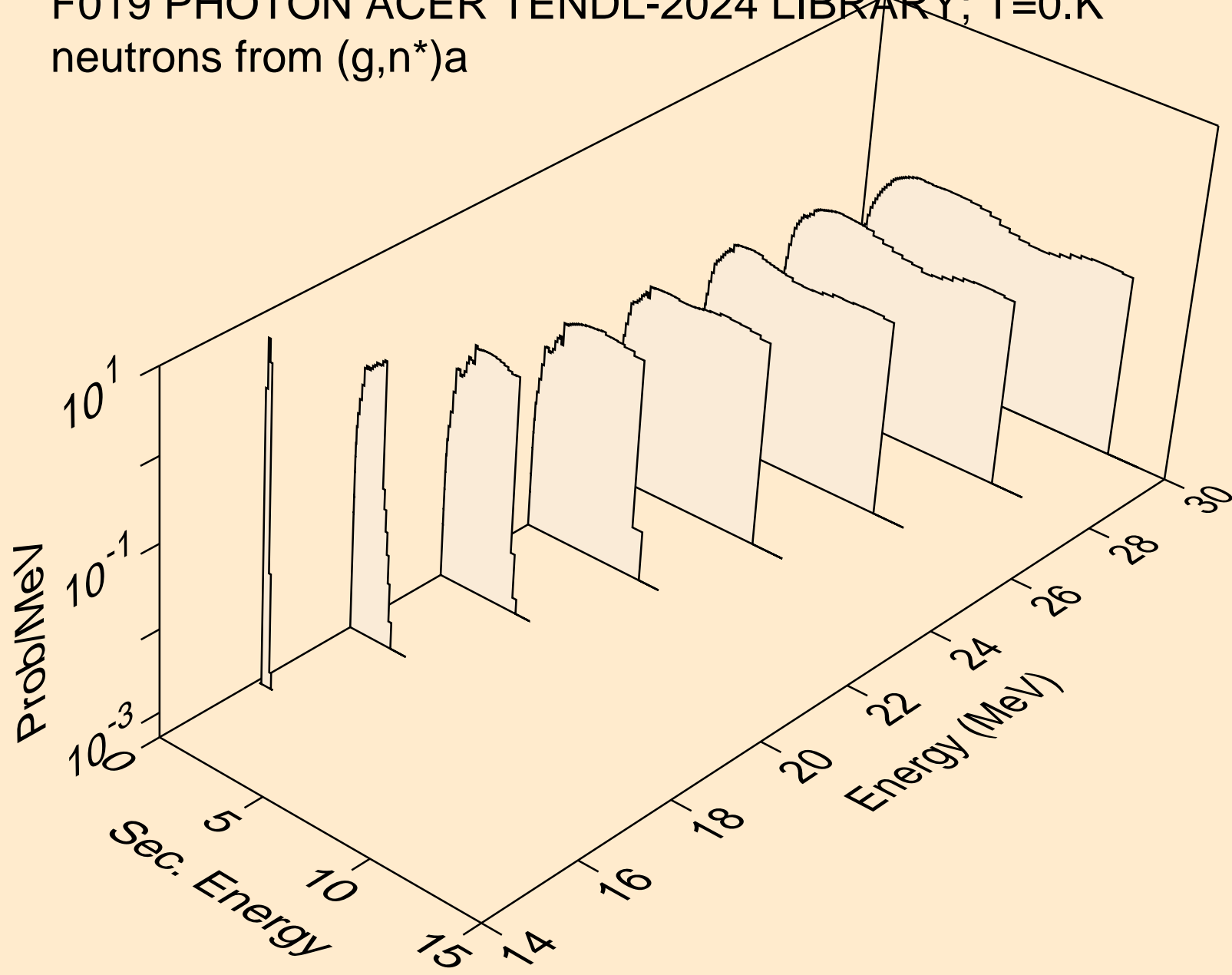

F019 PHOTON ACER TENDL-2024 LIBRARY; T=0.K
neutrons from (g,2n)a

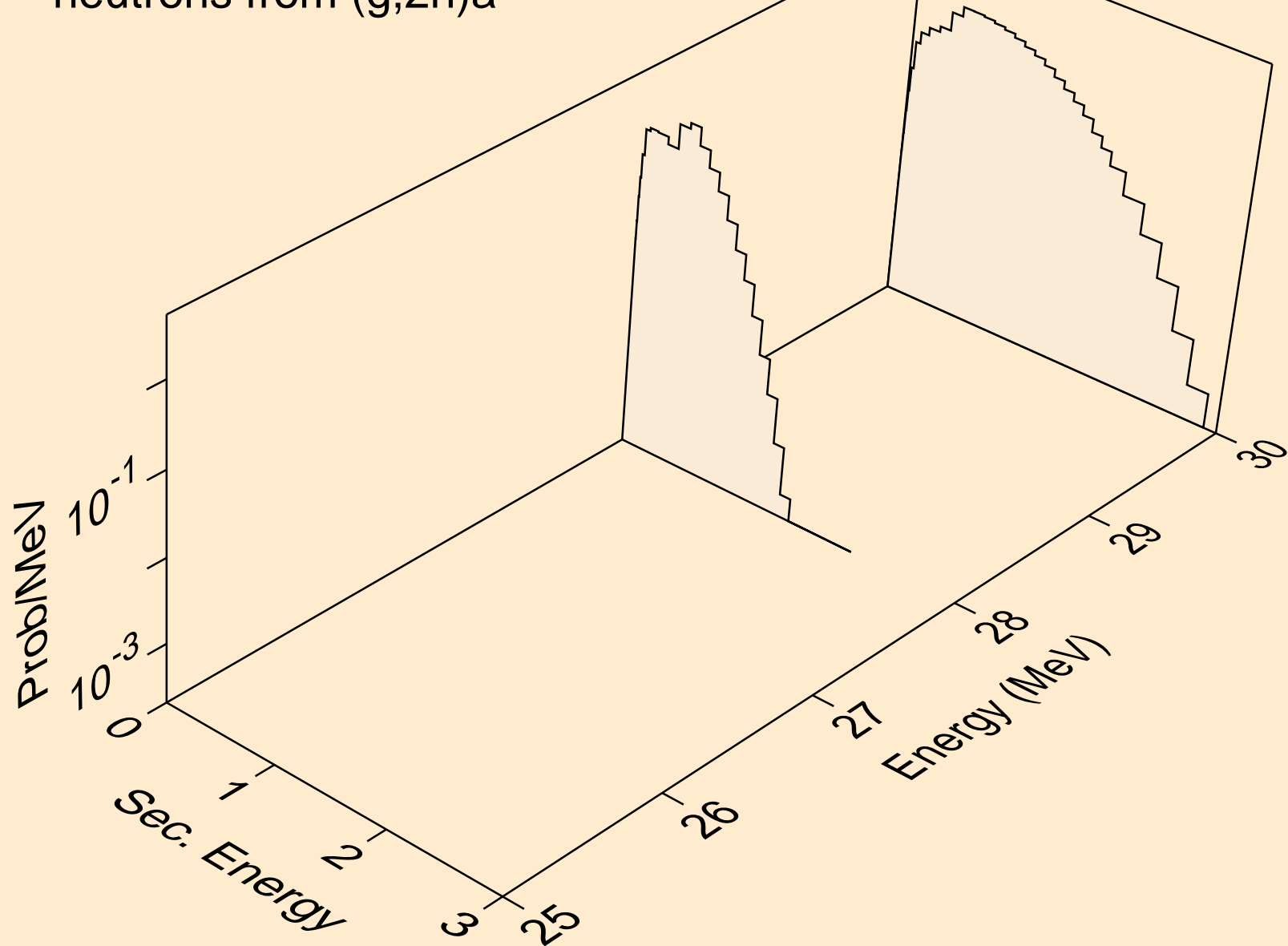

F019 PHOTON ACER TENDL-2024 LIBRARY; T=0.K
neutrons from (g,n*)p

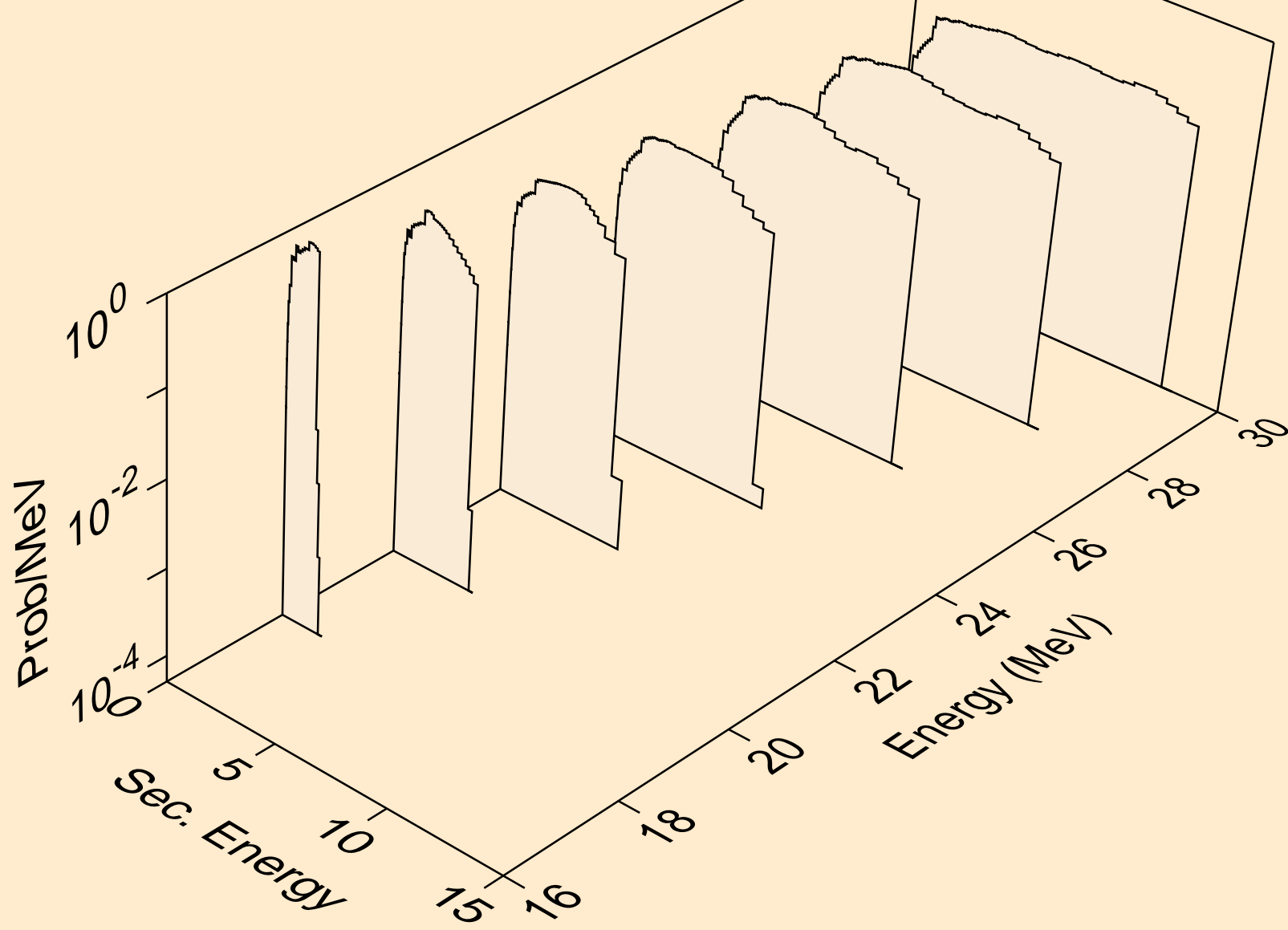

F019 PHOTON ACER TENDL-2024 LIBRARY; T=0.K
neutrons from (g,n*)d

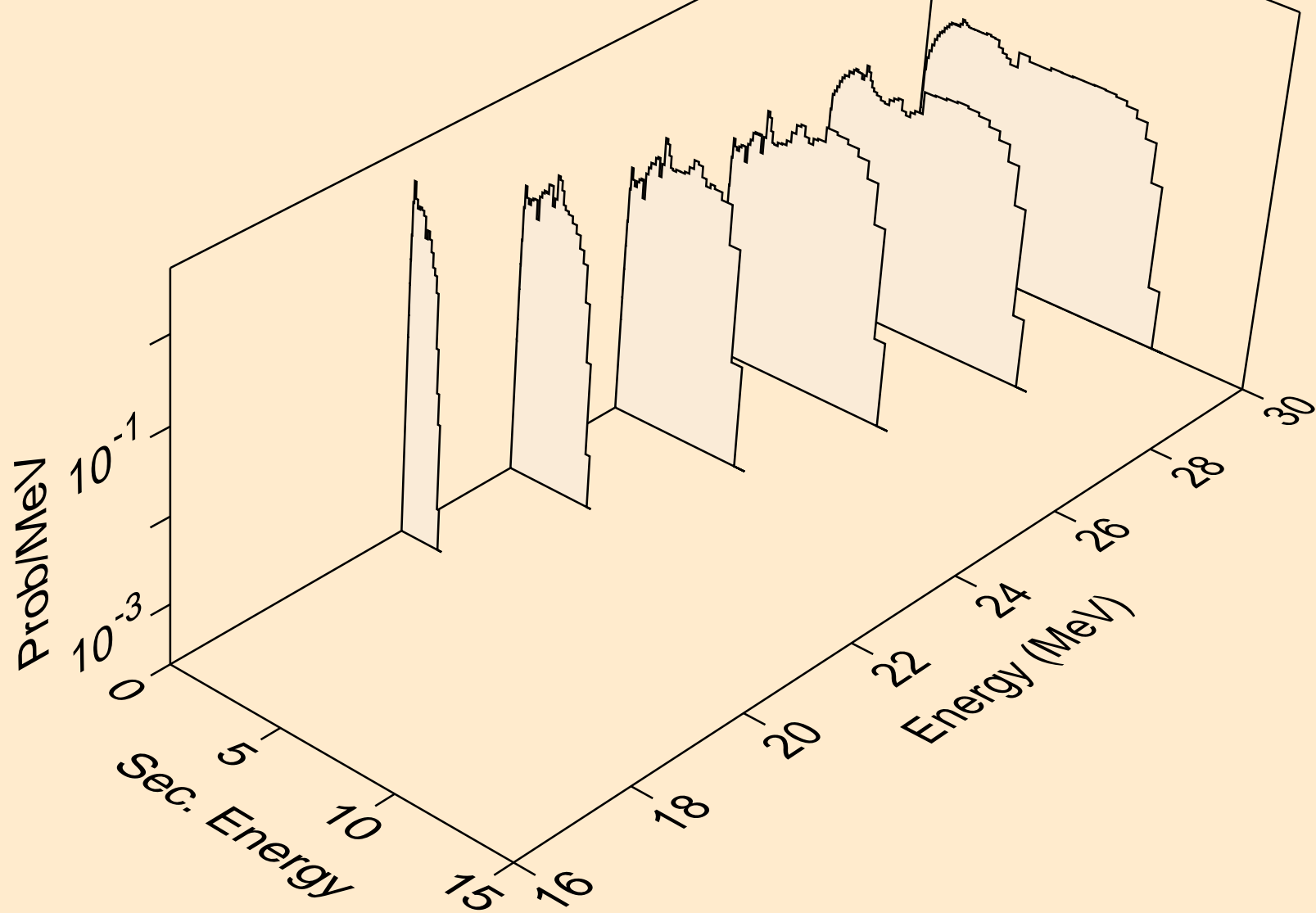

F019 PHOTON ACER TENDL-2024 LIBRARY; T=0.K
neutrons from (g,n*)t

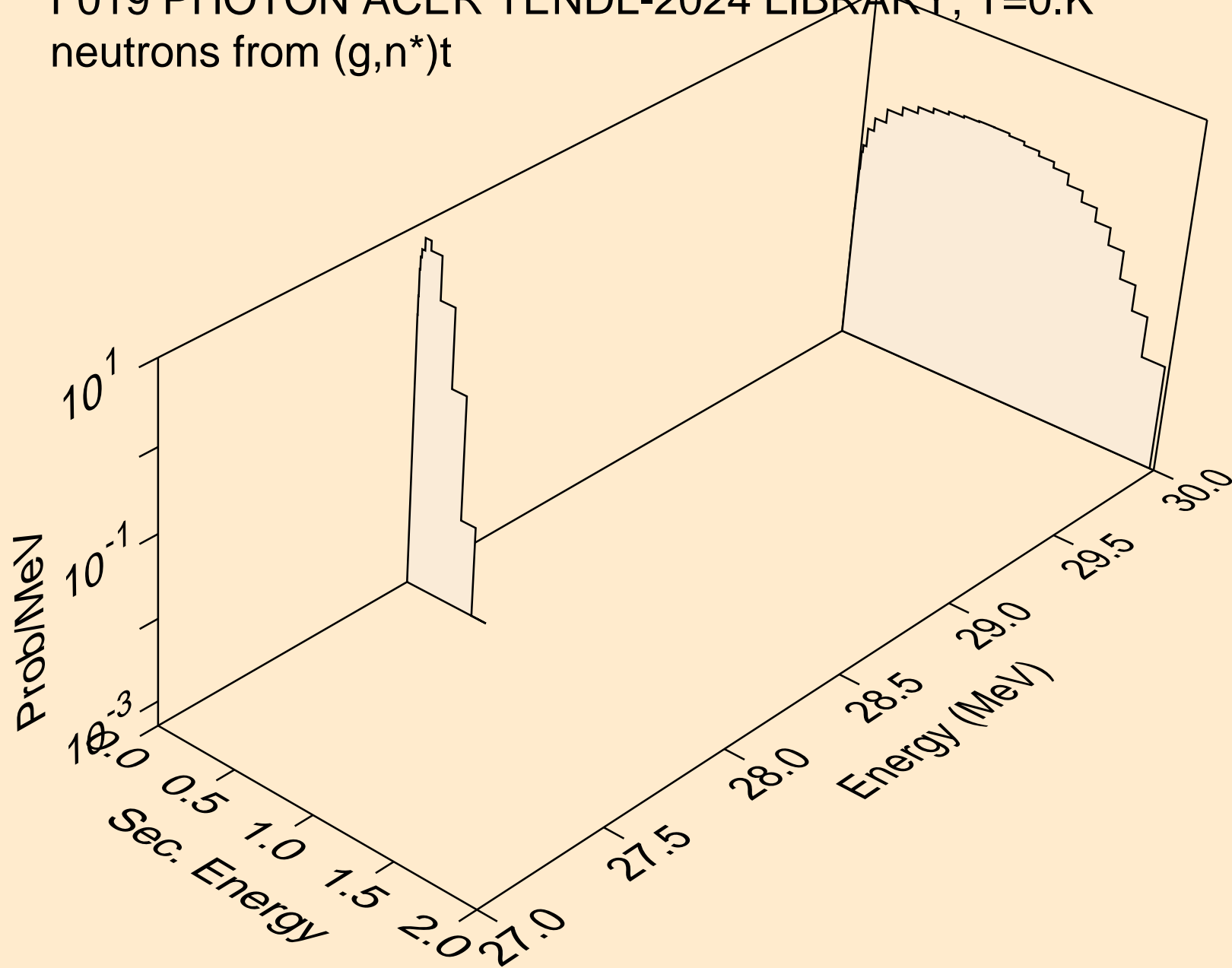

F019 PHOTON ACER TENDL-2024 LIBRARY; T=0.K
neutrons from (g,n*)he3

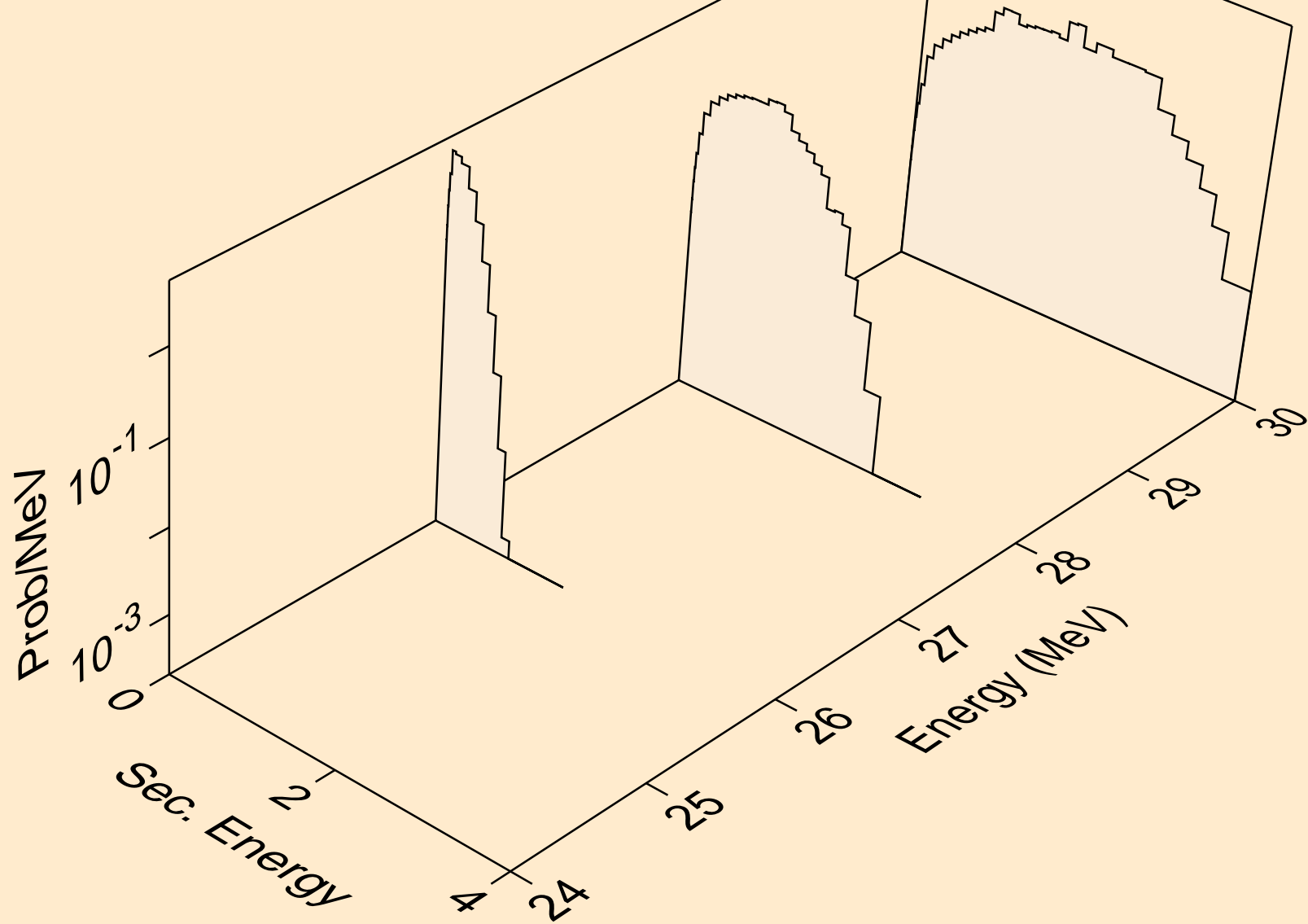

F019 PHOTON ACER TENDL-2024 LIBRARY; T=0.K
neutrons from (g,2np)

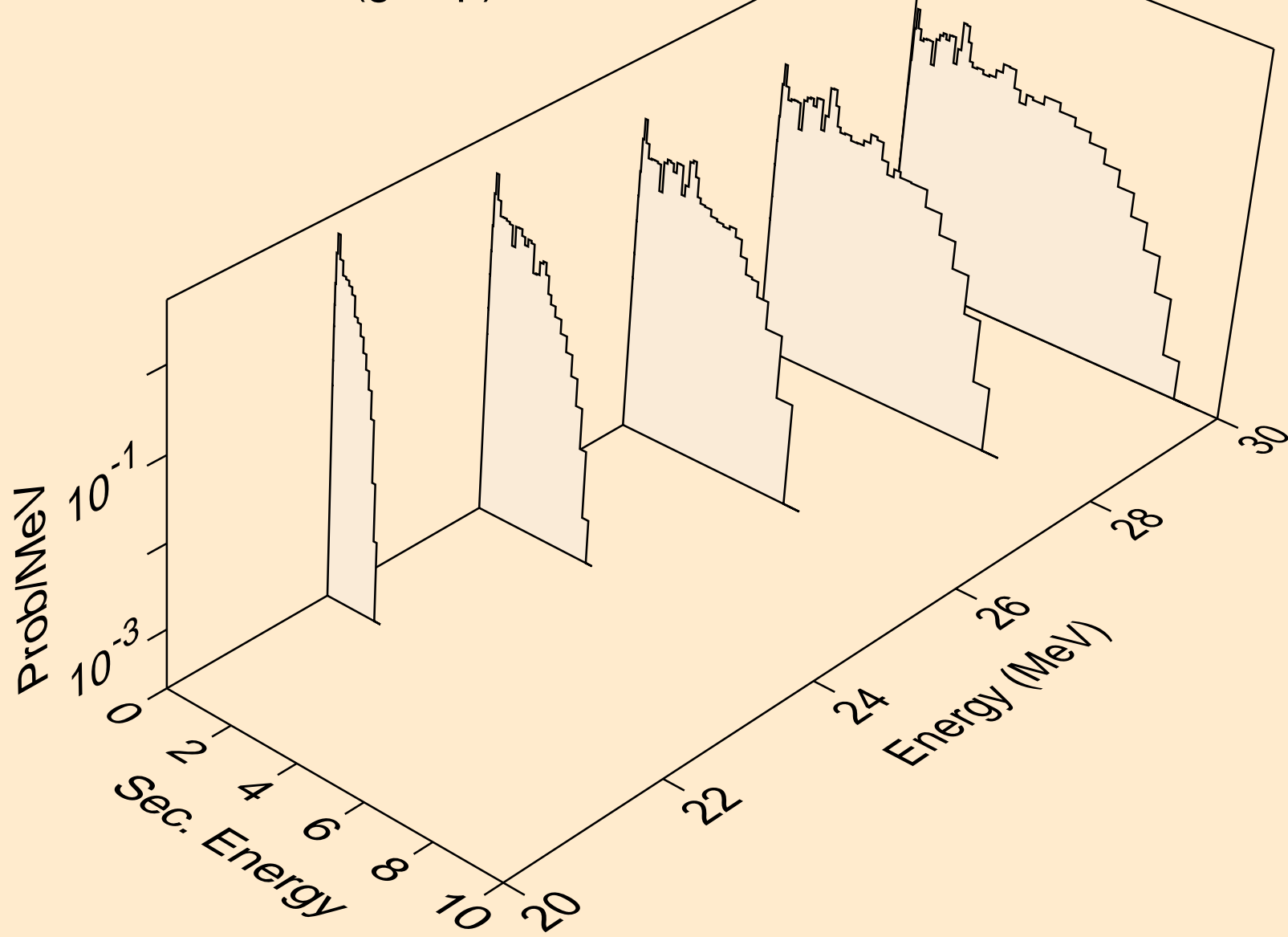

F019 PHOTON ACER TENDL-2024 LIBRARY; T=0.K
neutrons from (g,npa)

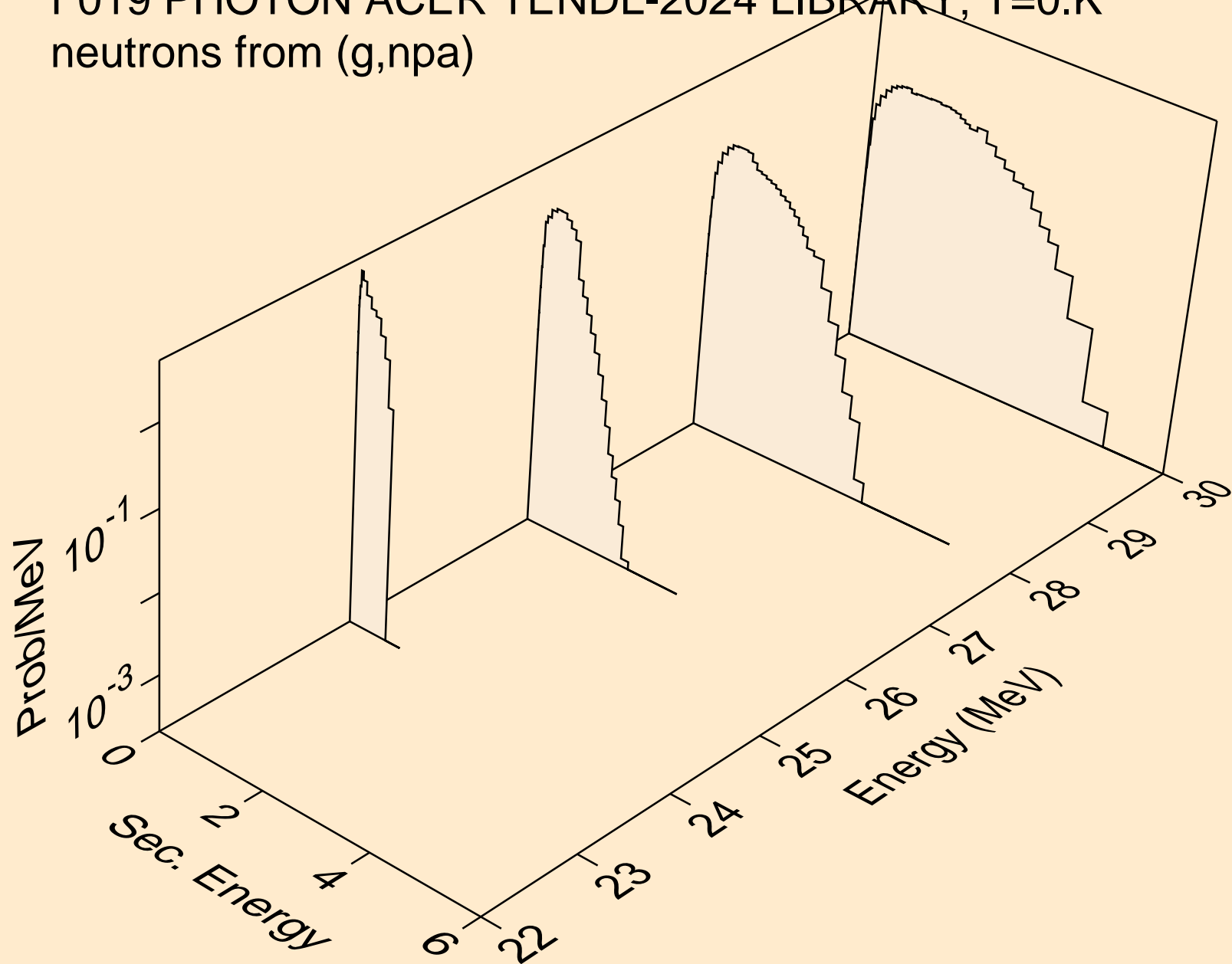

F019 PHOTON ACER TENDL-2024 LIBRARY; T=0.K
angular distribution for (g,n*0) neutron

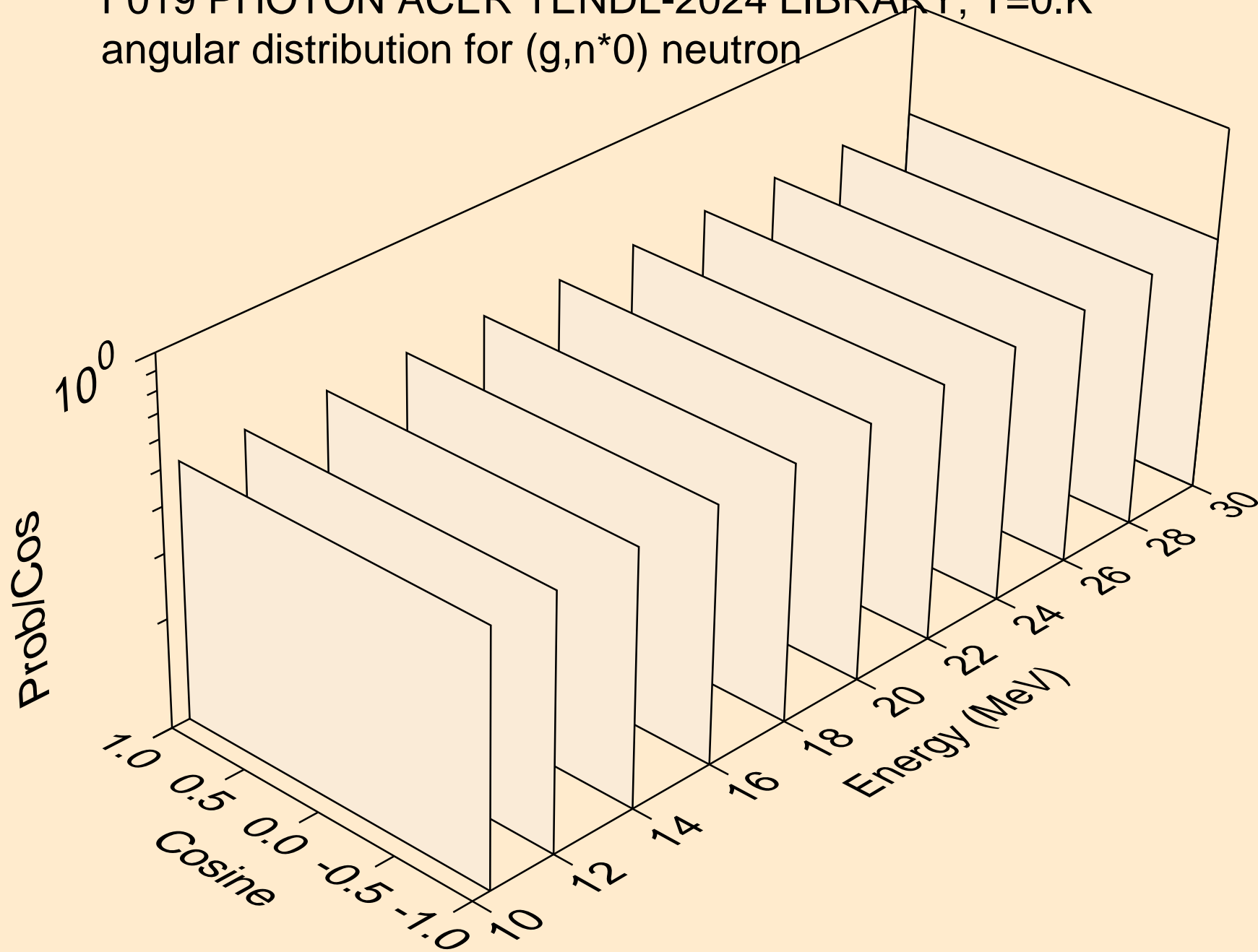

F019 PHOTON ACER TENDL-2024 LIBRARY; T=0.K
angular distribution for (g,n*1) neutron

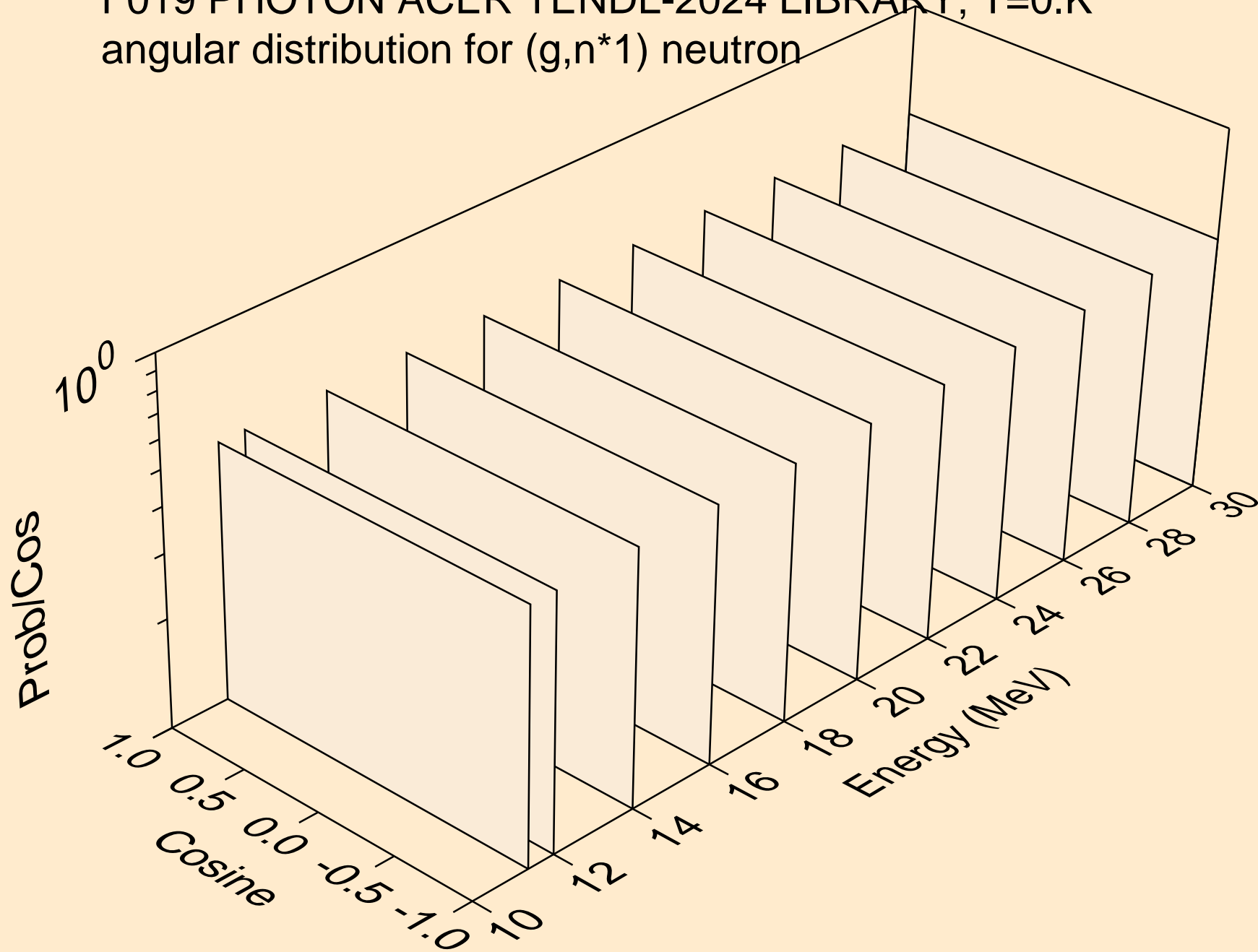

F019 PHOTON ACER TENDL-2024 LIBRARY; T=0.K
neutrons from (g,n*c)

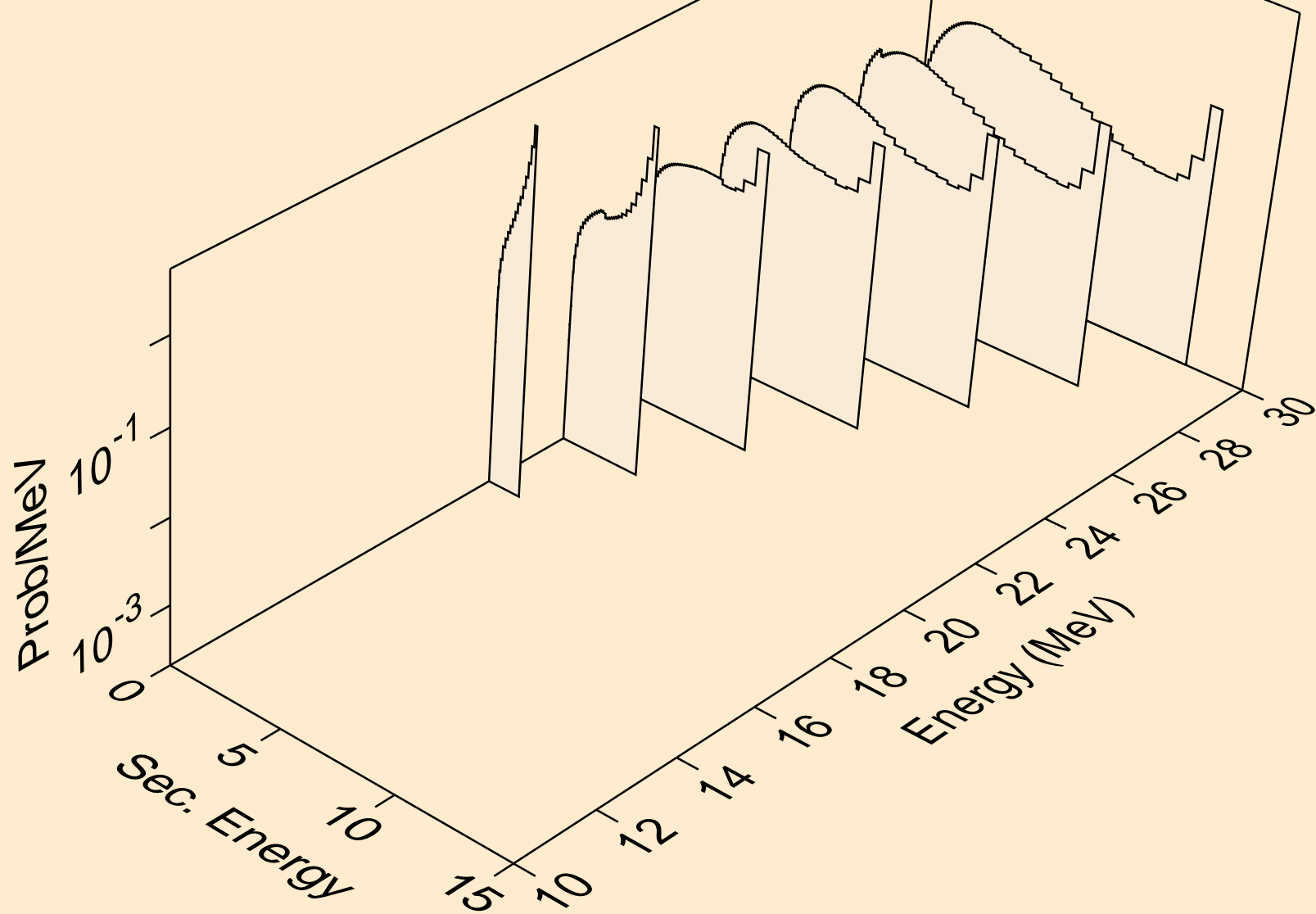

F019 PHOTON ACER TENDL-2024 LIBRARY; T=0.K
photons from (g,x)

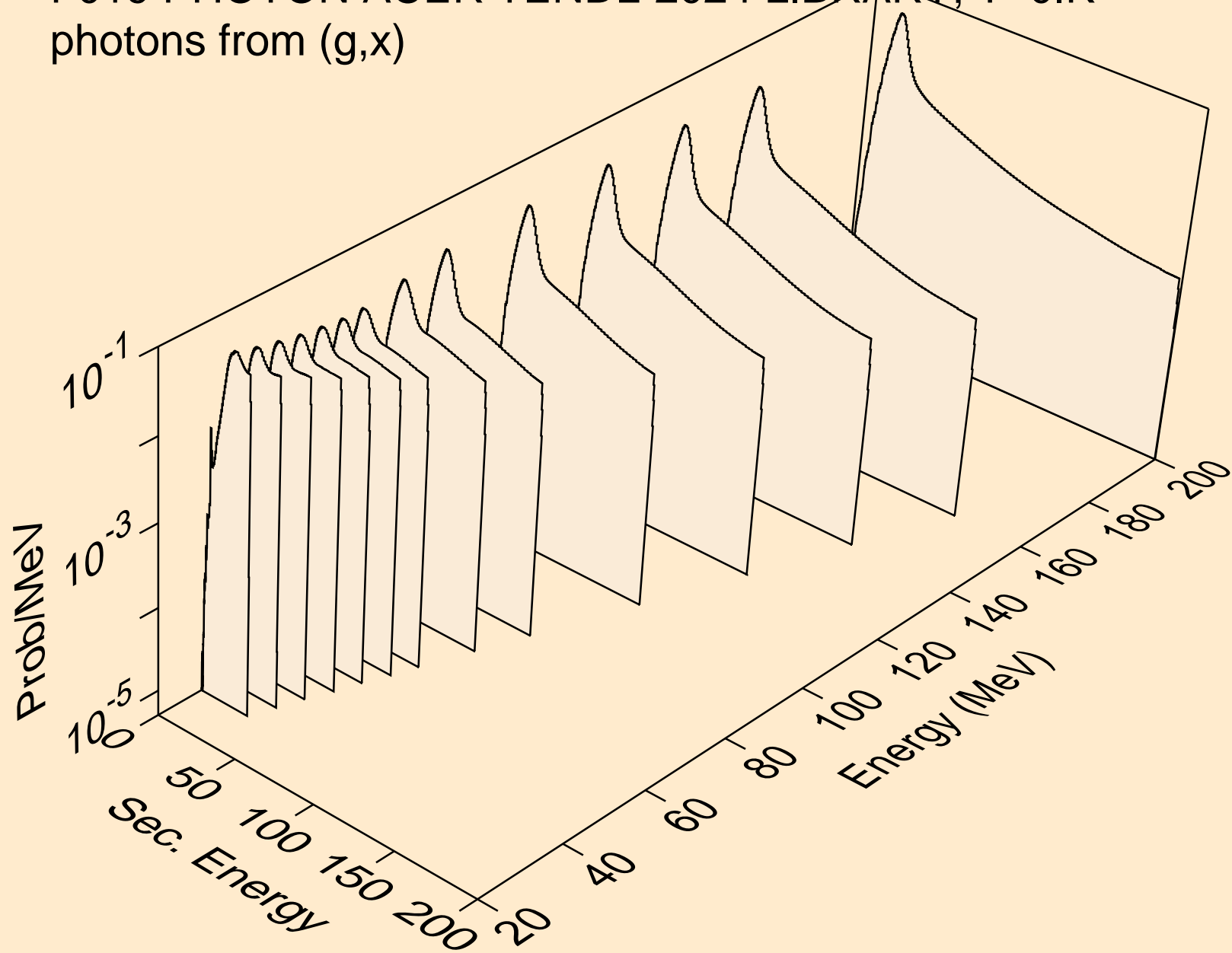

F019 PHOTON ACER TENDL-2024 LIBRARY; T=0.K
photons from (g,2n)

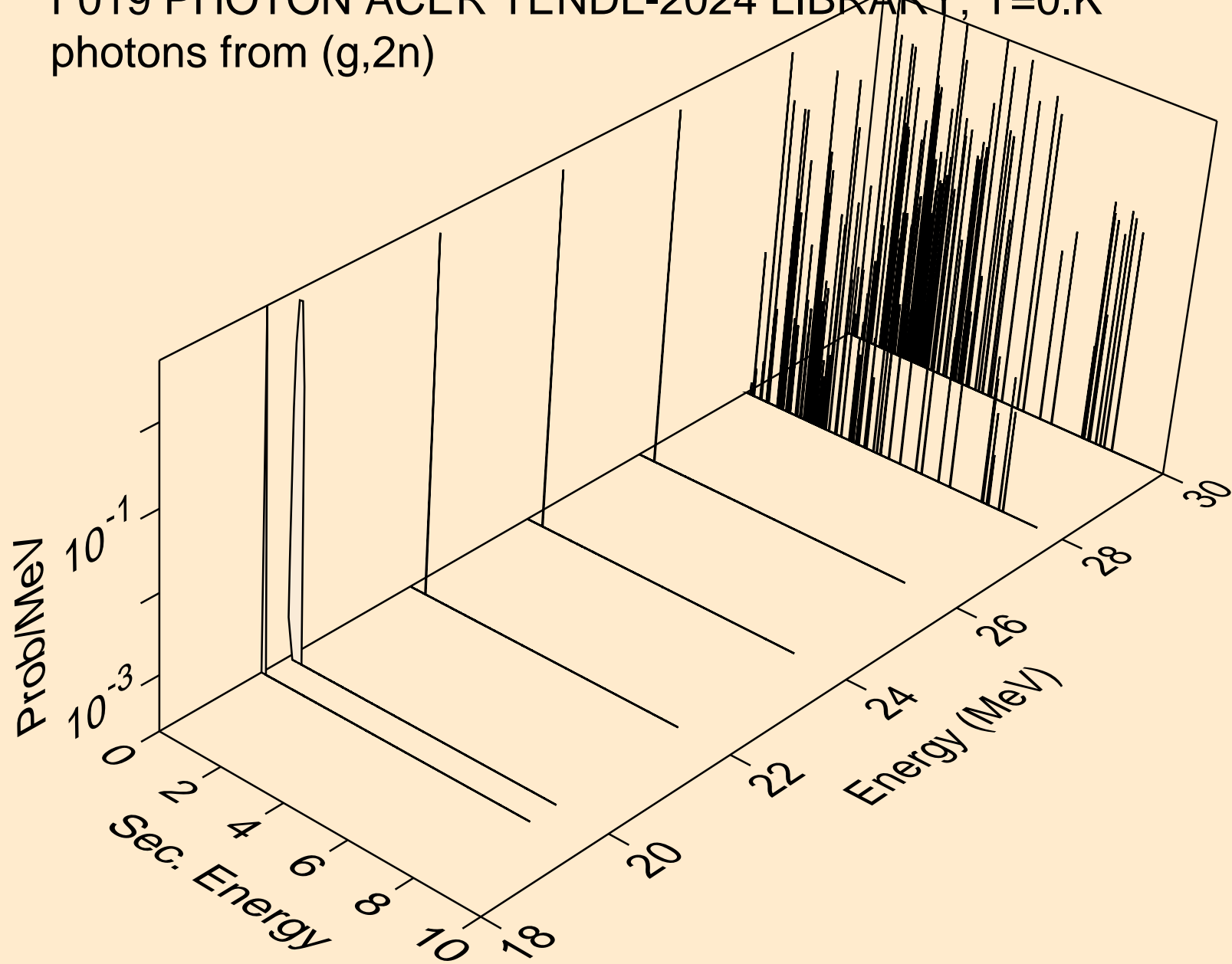

F019 PHOTON ACER TENDL-2024 LIBRARY; T=0.K
photons from (g,n*)a

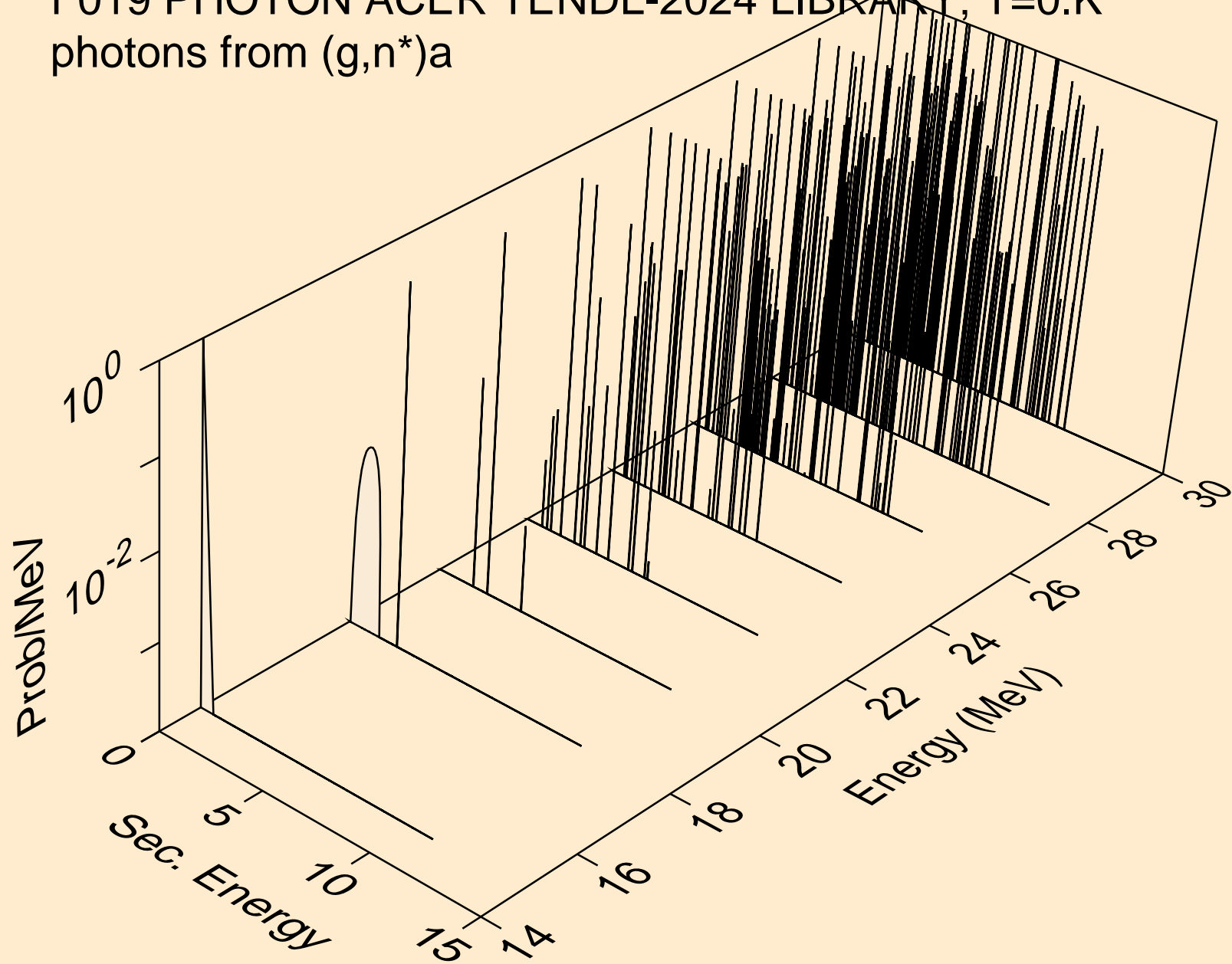

F019 PHOTON ACER TENDL-2024 LIBRARY; T=0.K
photons from (g,2n)a

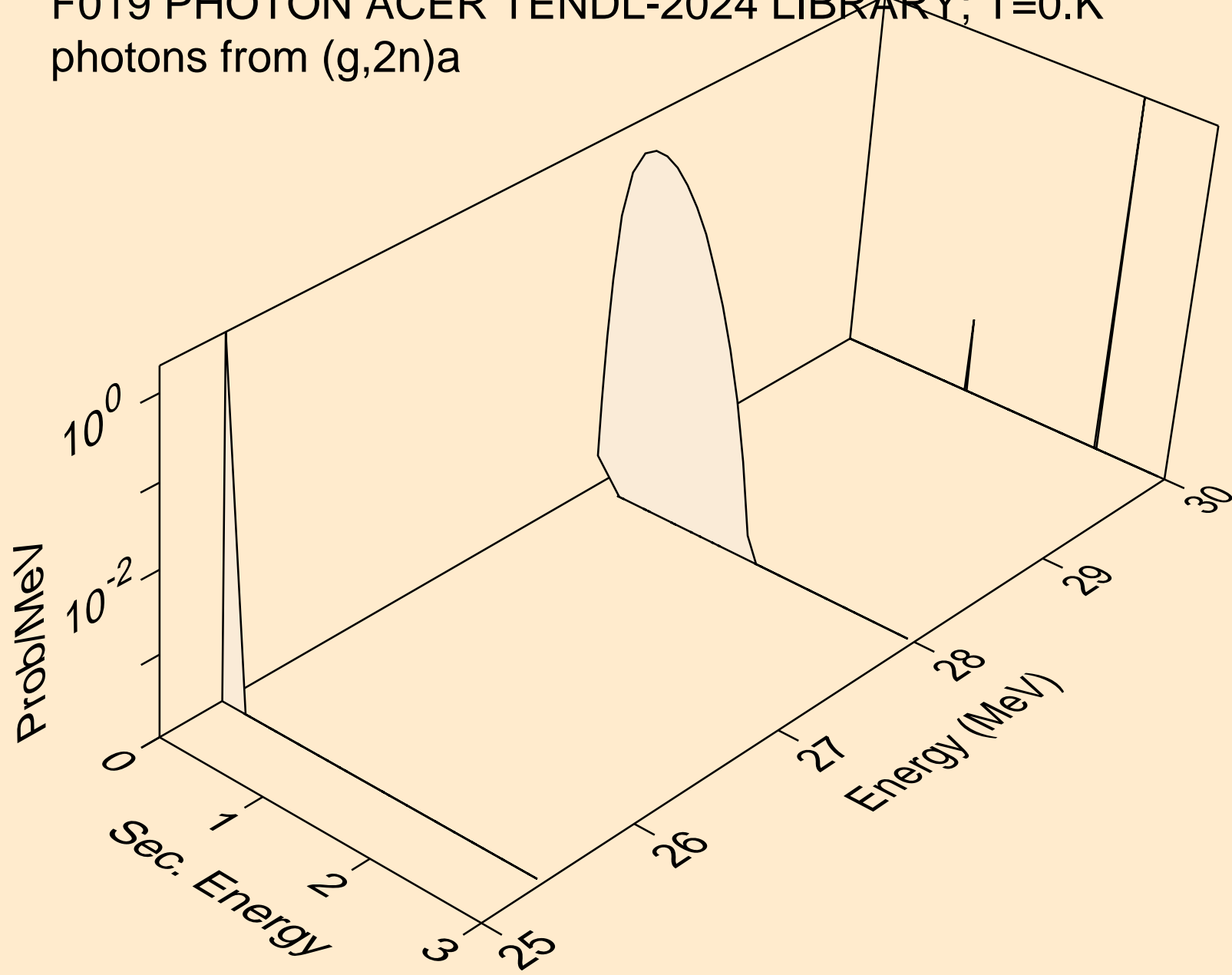

F019 PHOTON ACER TENDL-2024 LIBRARY; T=0.K
photons from (g,n*)p

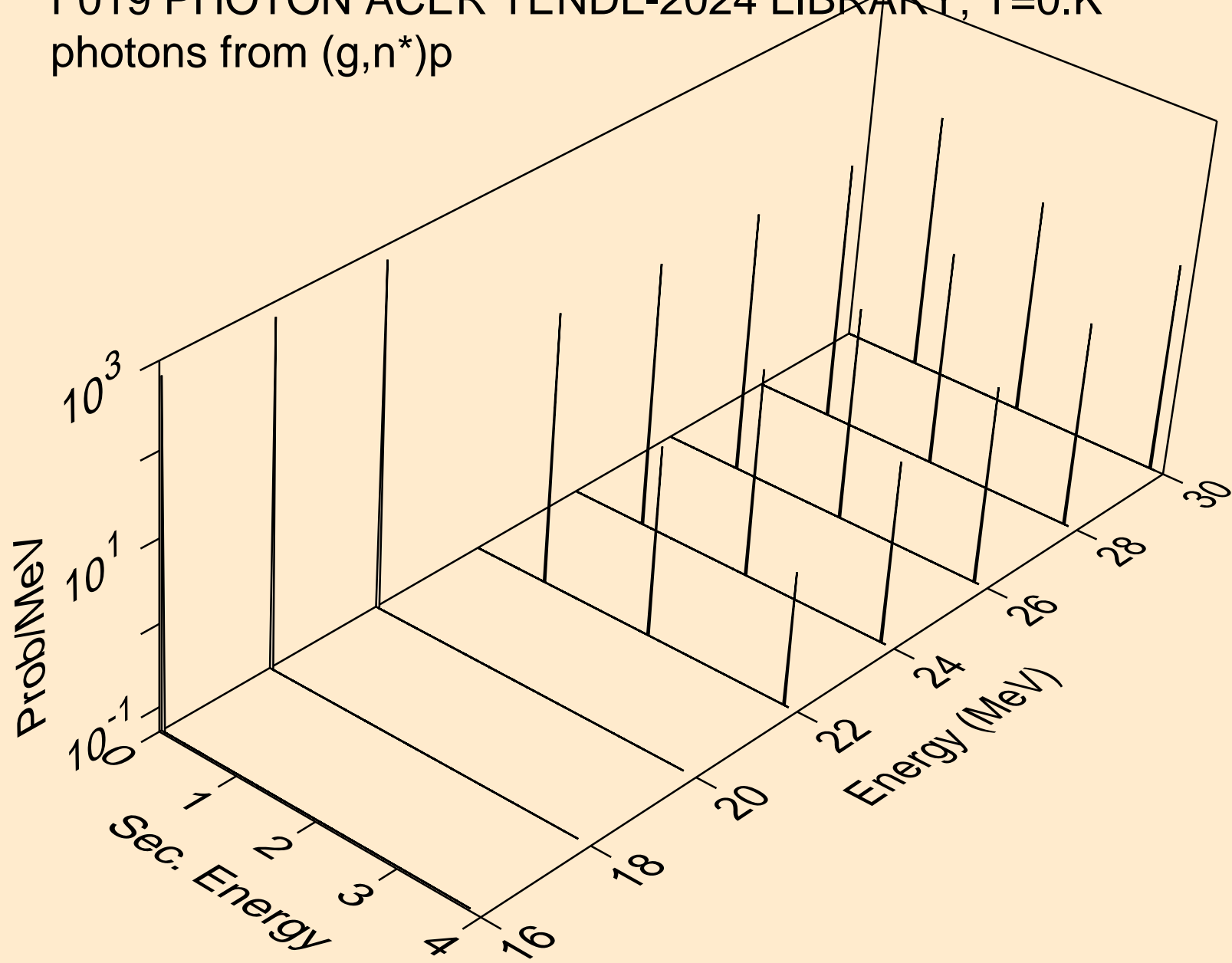

F019 PHOTON ACER TENDL-2024 LIBRARY; T=0.K
photons from (g,n*)d

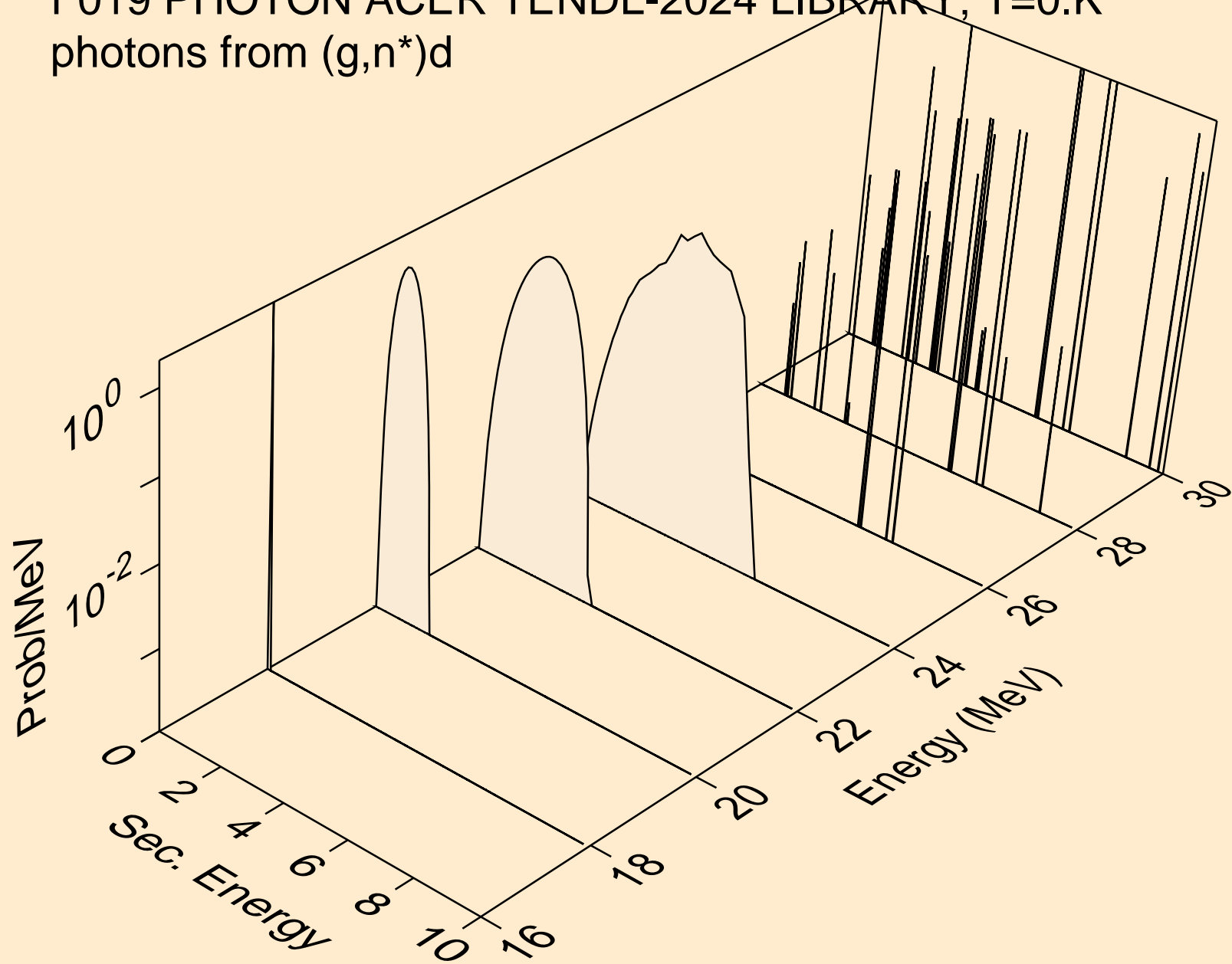

F019 PHOTON ACER TENDL-2024 LIBRARY; T=0.K
photons from (g,n*)t

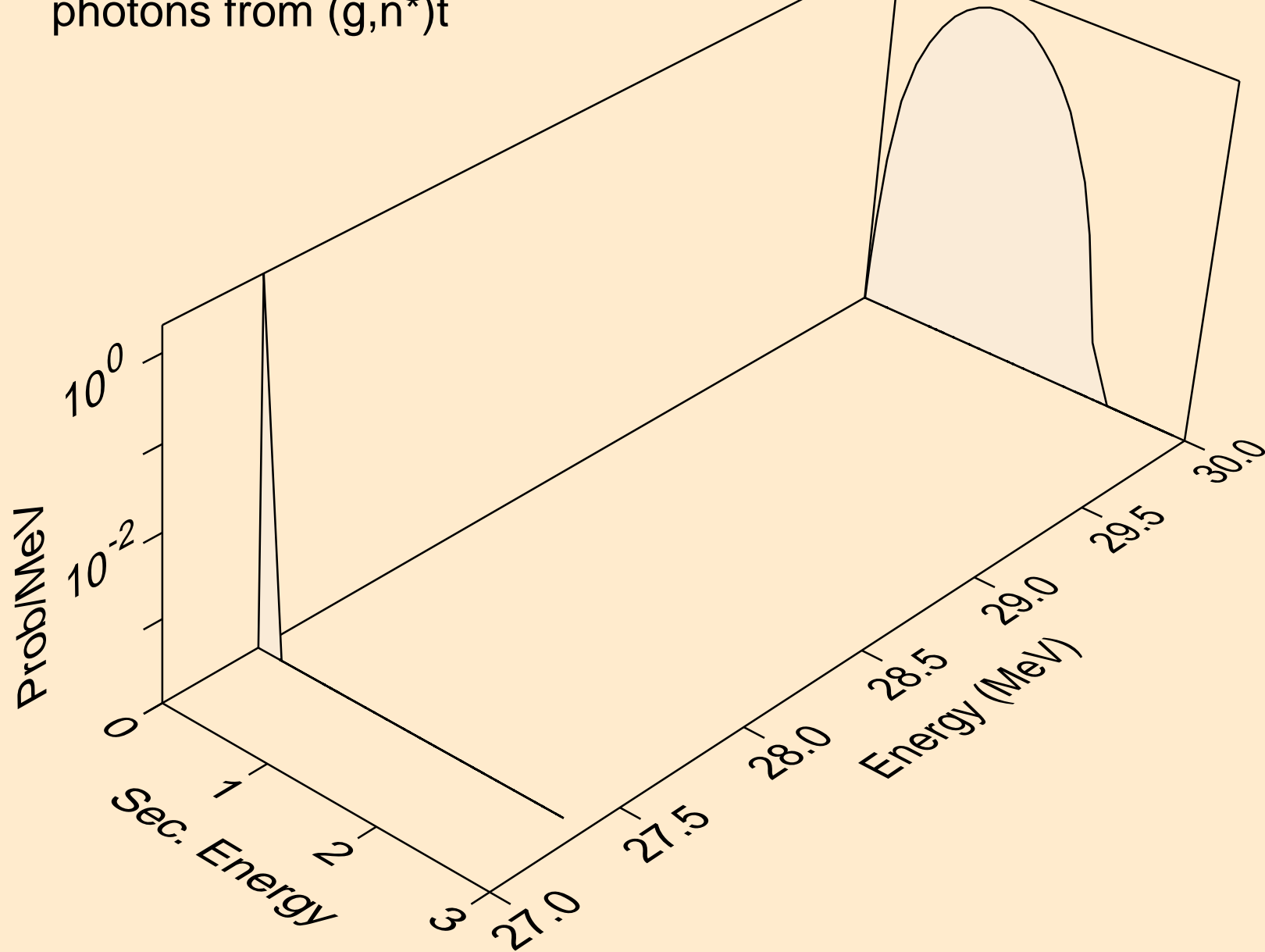

F019 PHOTON ACER TENDL-2024 LIBRARY; T=0.K
photons from (g,n*)he3

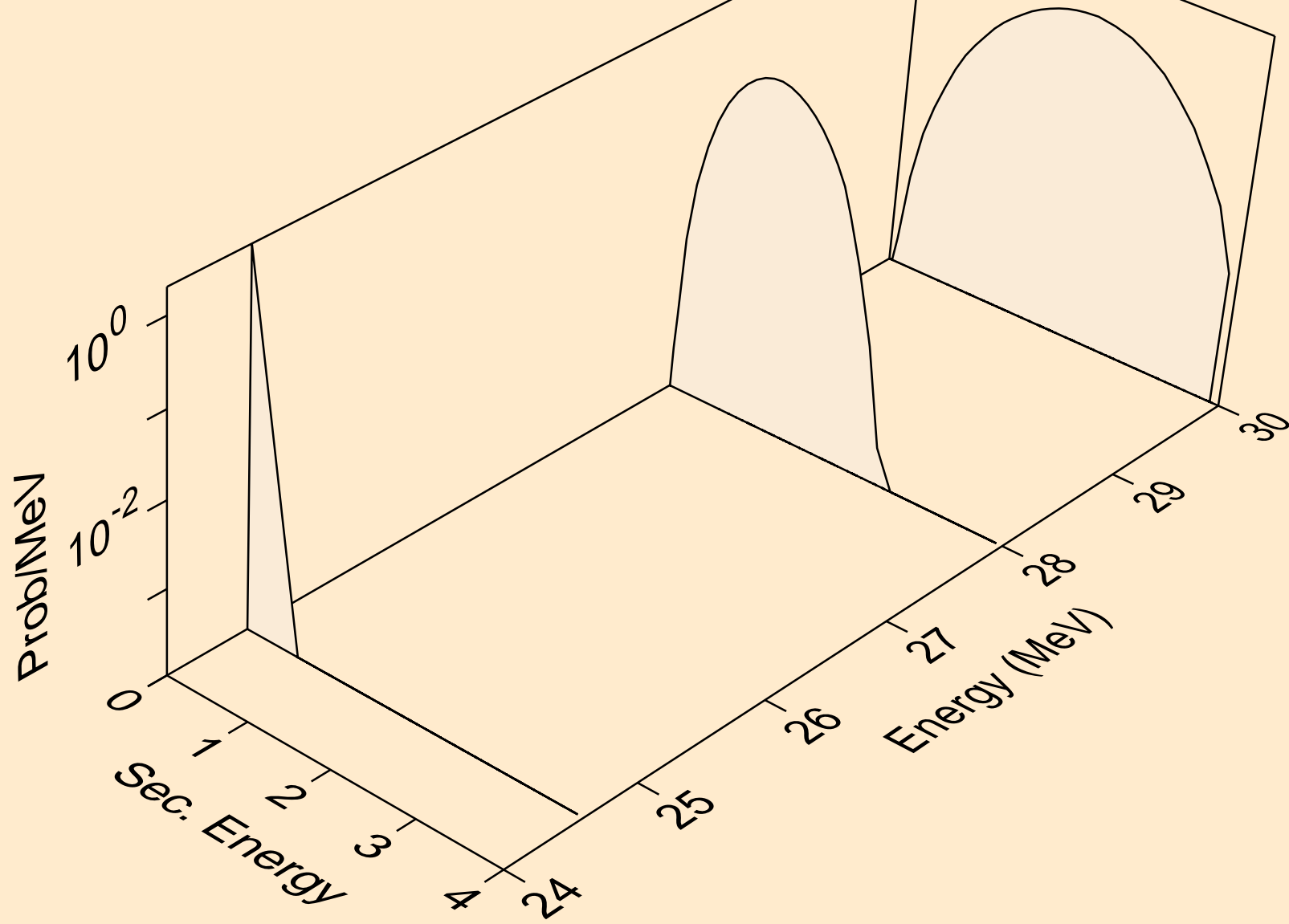

F019 PHOTON ACER TENDL-2024 LIBRARY; T=0.K
photons from (g,2np)

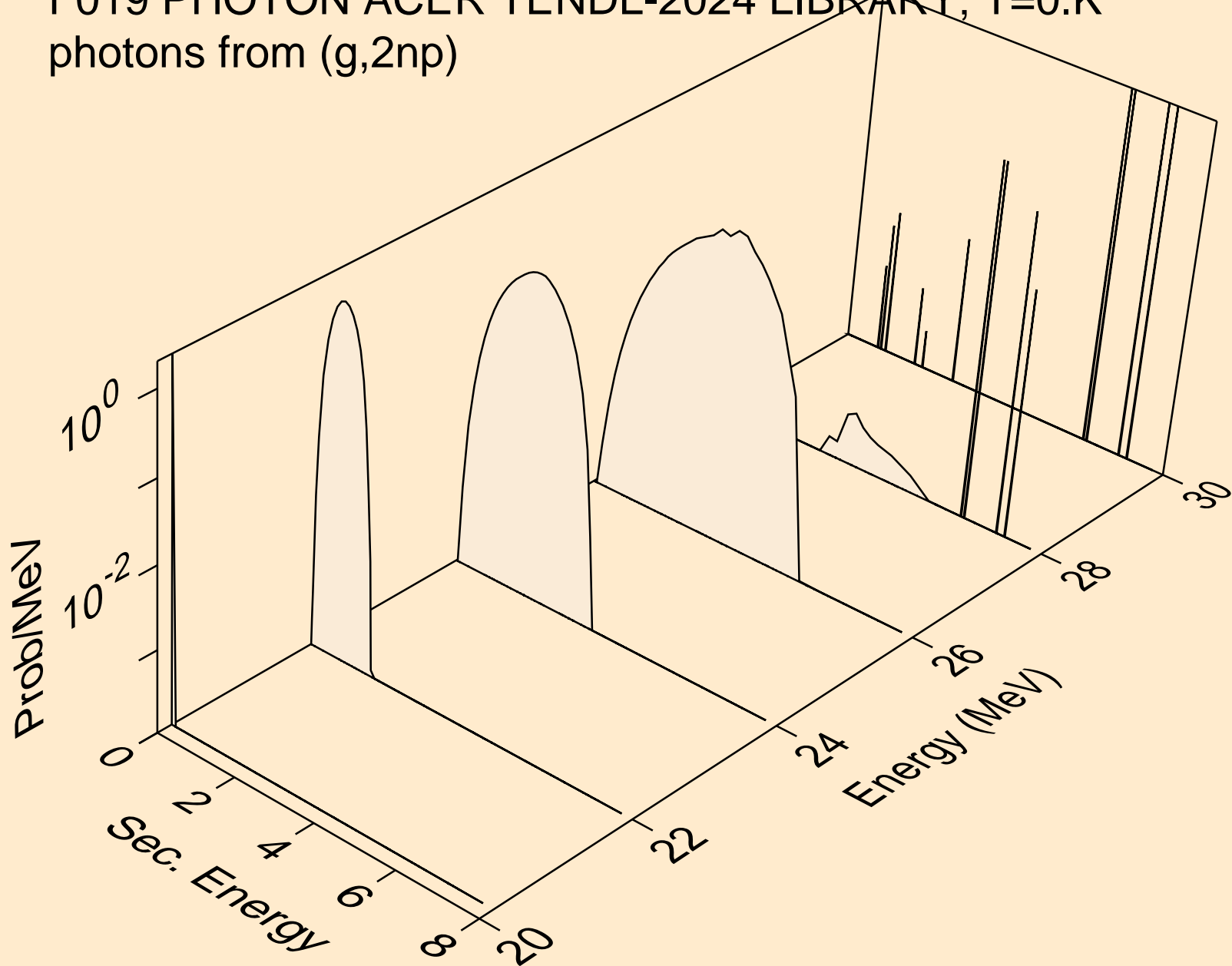

F019 PHOTON ACER TENDL-2024 LIBRARY; T=0.K
photons from (g,npa)

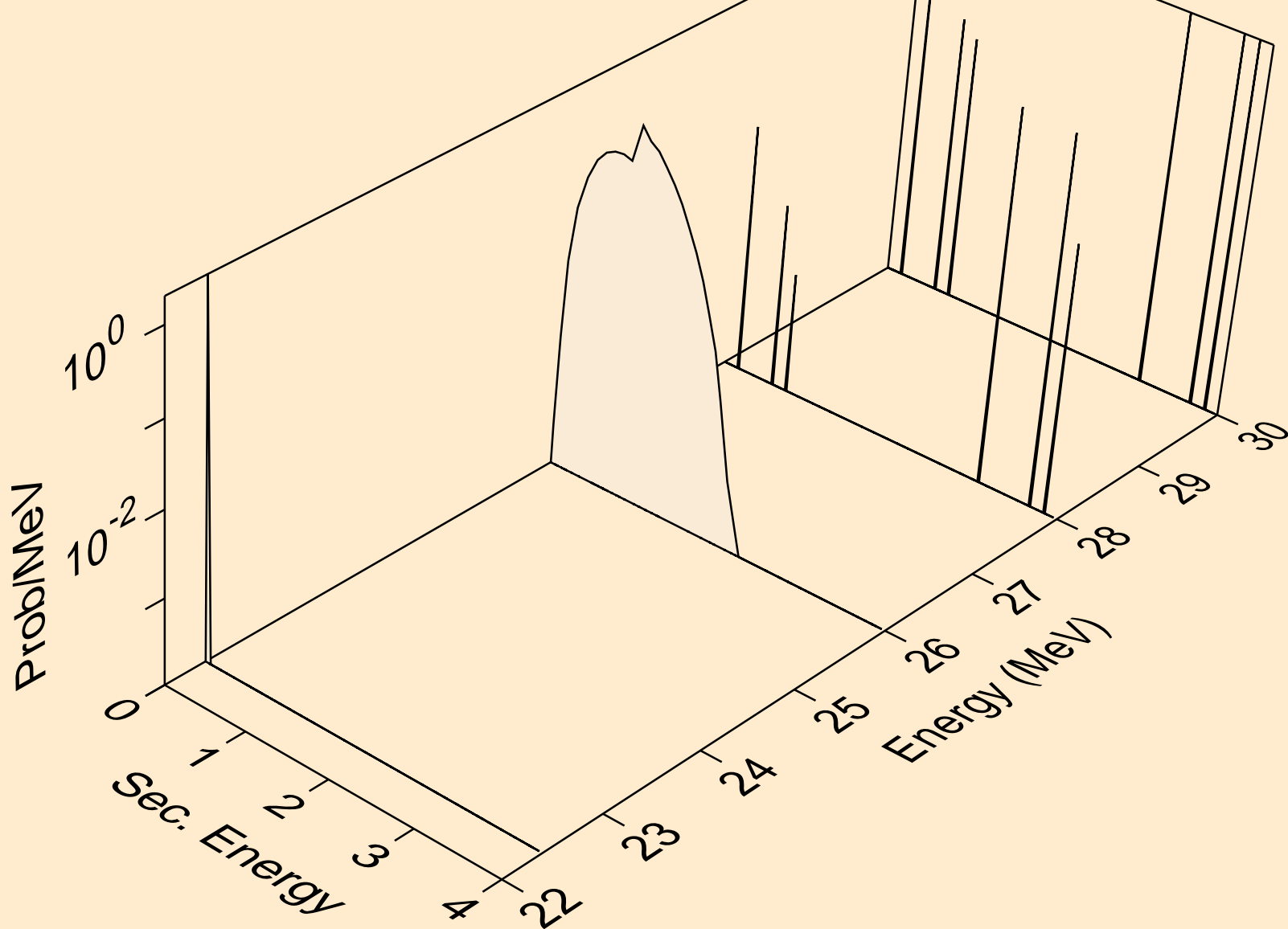

F019 PHOTON ACER TENDL-2024 LIBRARY; T=0.K
photons from (g,n*c)

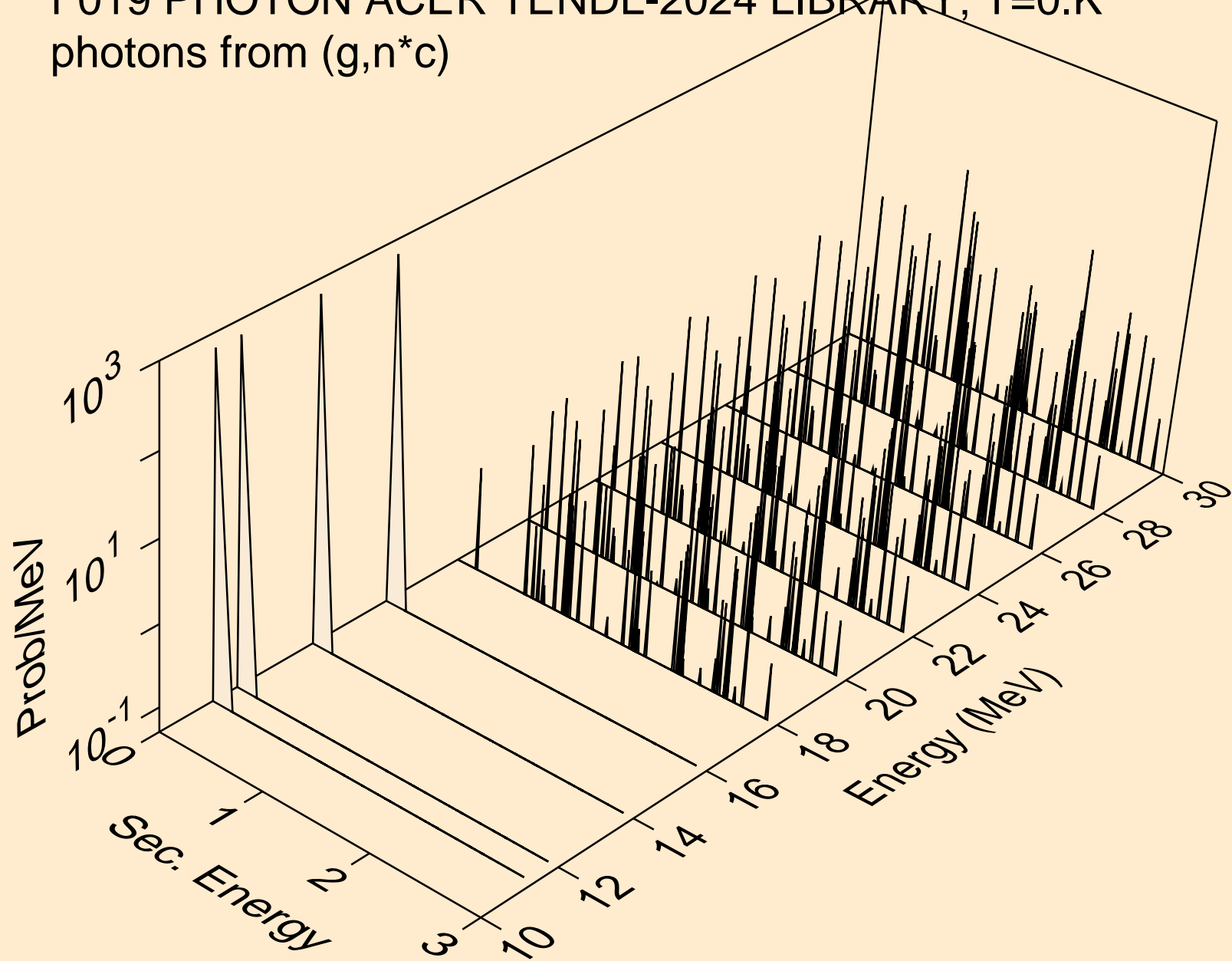

F019 PHOTON ACER TENDL-2024 LIBRARY; T=0.K
photons from (g,gma)

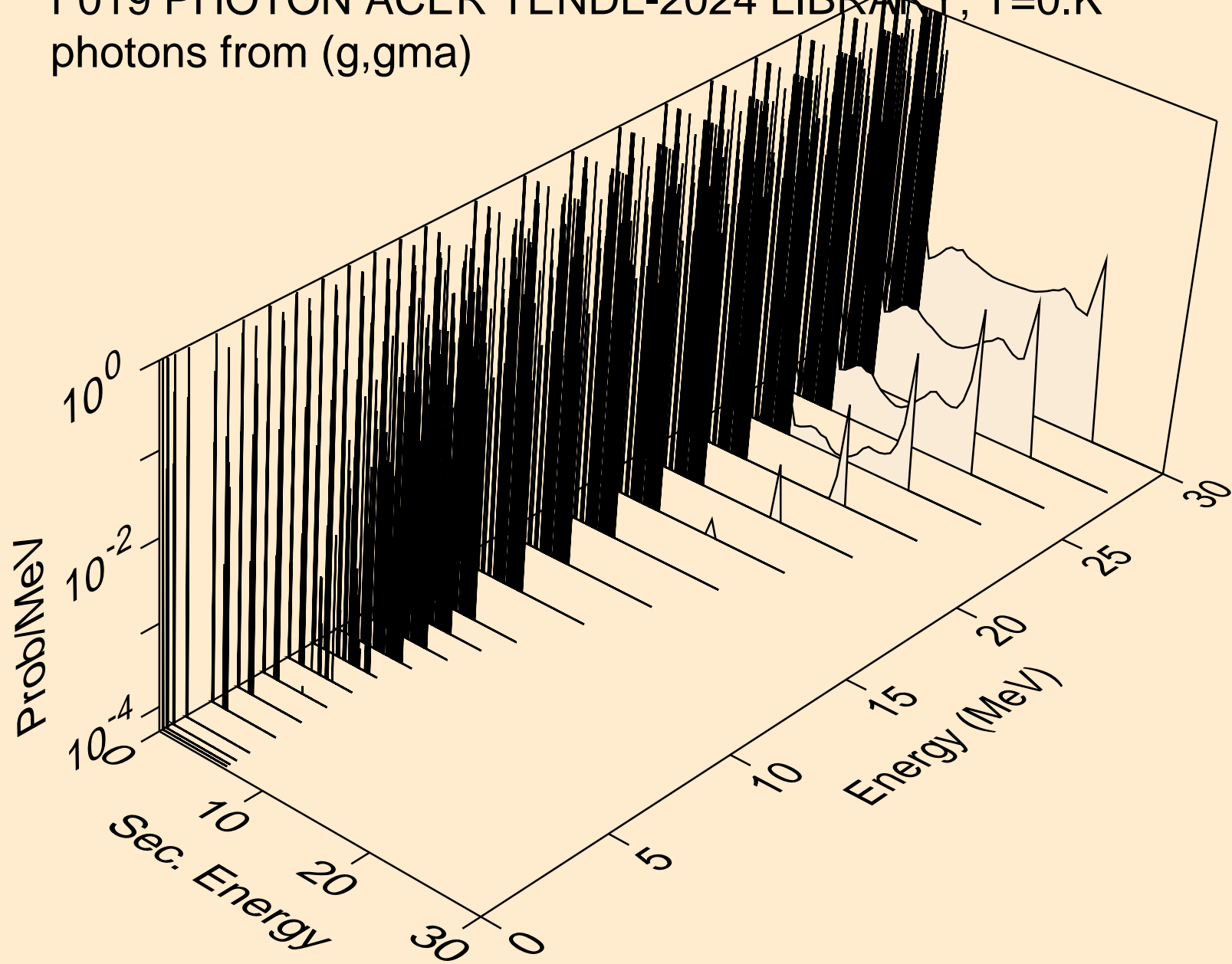

F019 PHOTON ACER TENDL-2024 LIBRARY; T=0.K
photons from (g,p)

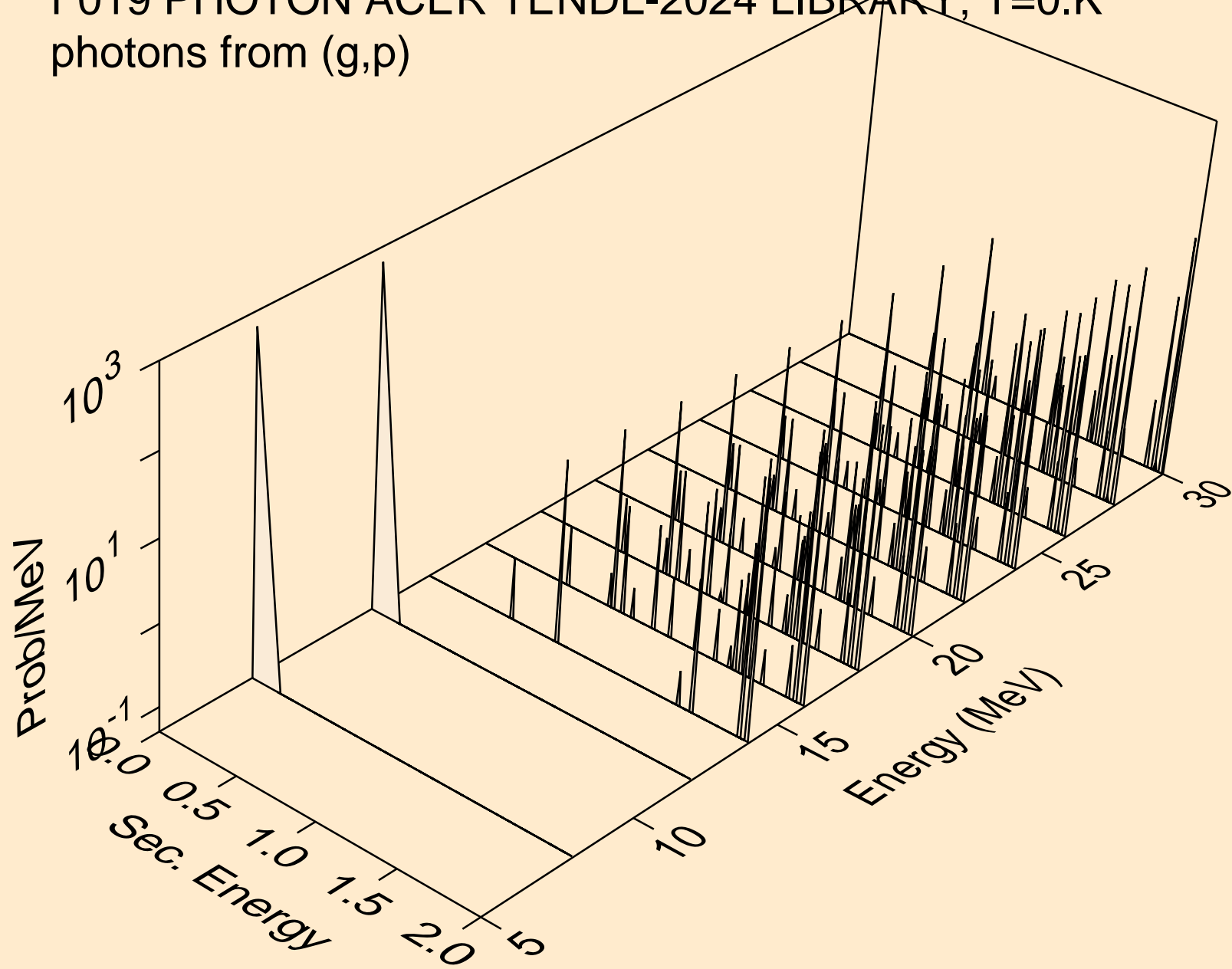

F019 PHOTON ACER TENDL-2024 LIBRARY; T=0.K
photons from (g,d)

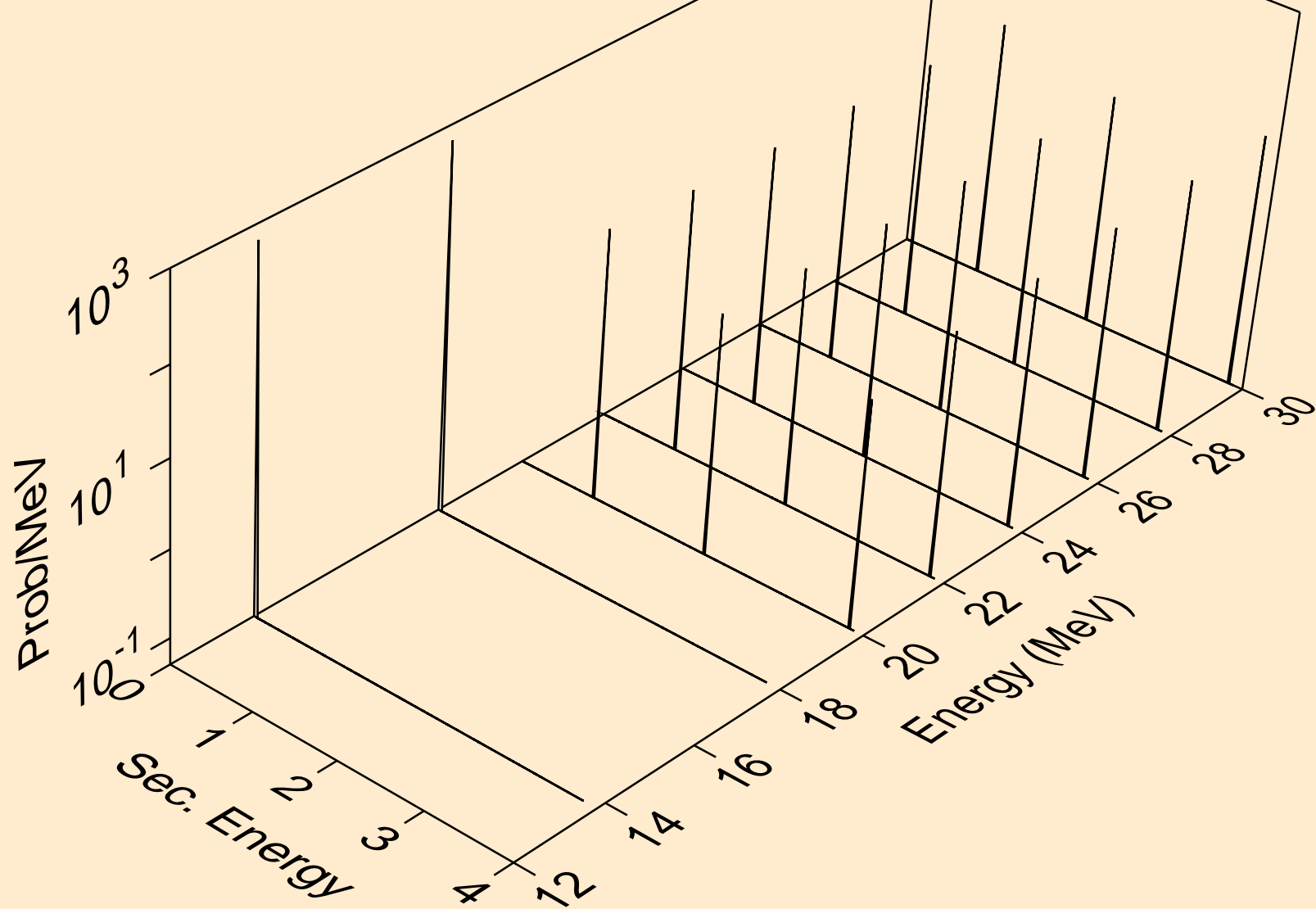

F019 PHOTON ACER TENDL-2024 LIBRARY; T=0.K
photons from (g,t)

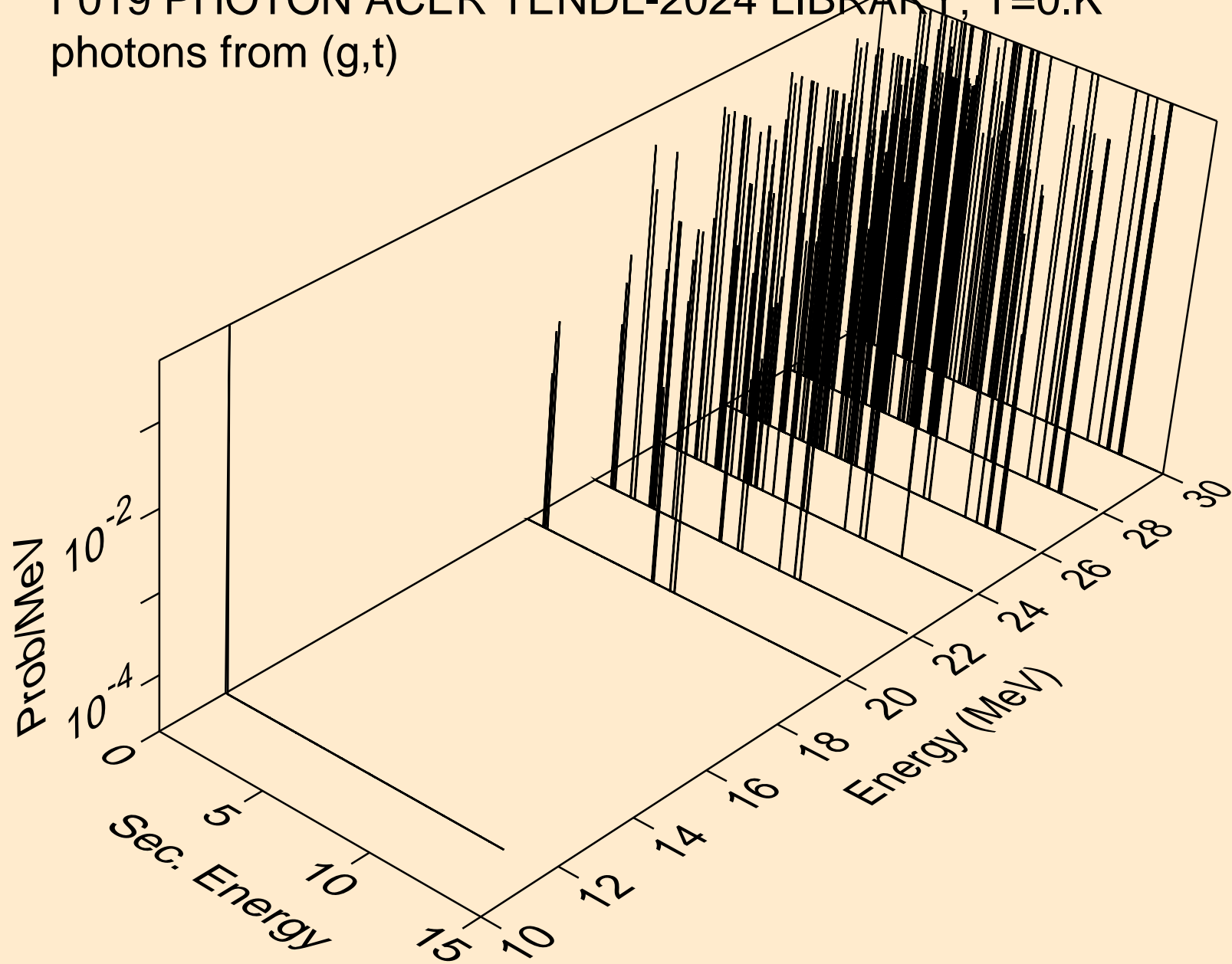

F019 PHOTON ACER TENDL-2024 LIBRARY; T=0.K
photons from (g,he3)

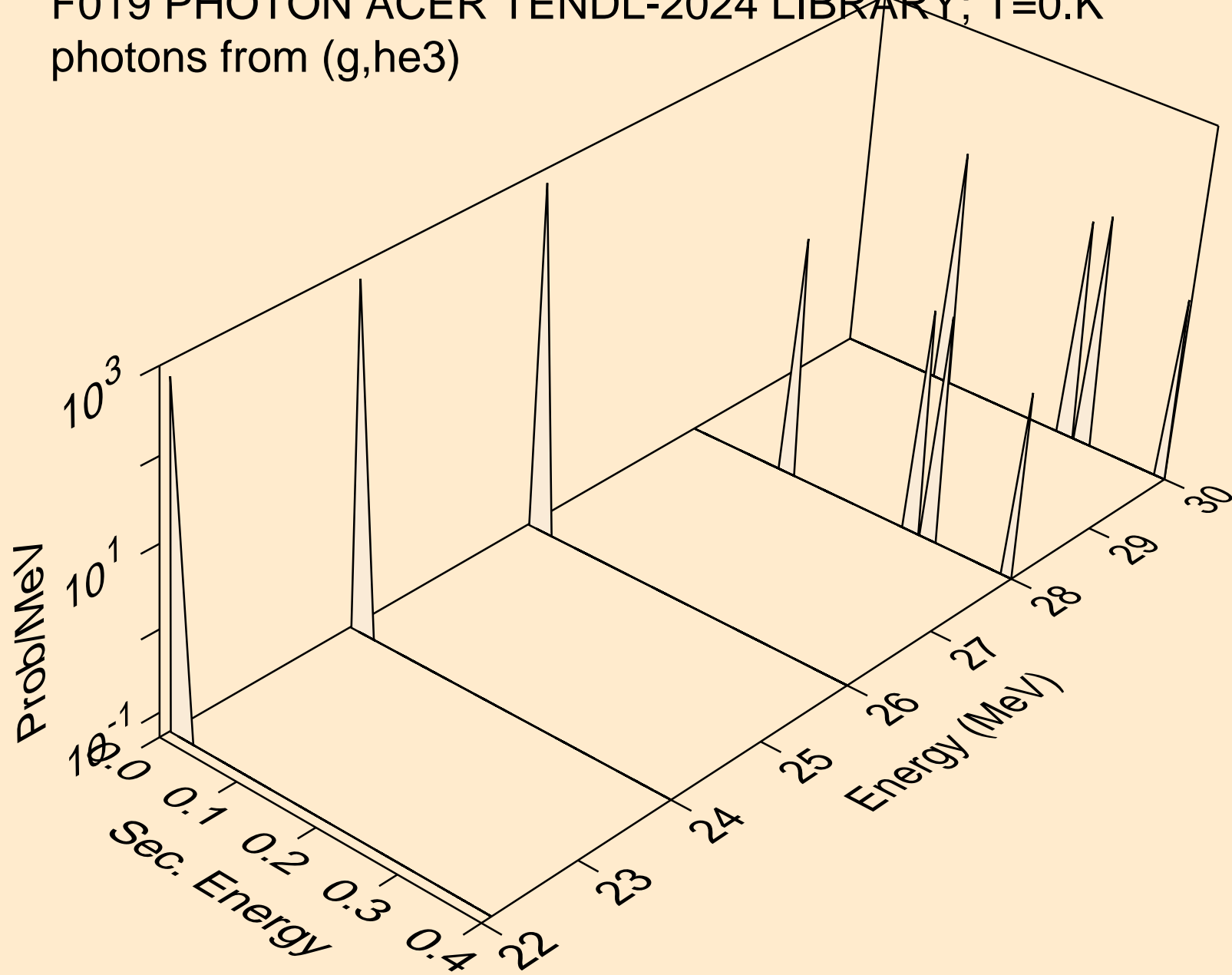

F019 PHOTON ACER TENDL-2024 LIBRARY; T=0.K
photons from (g,a)

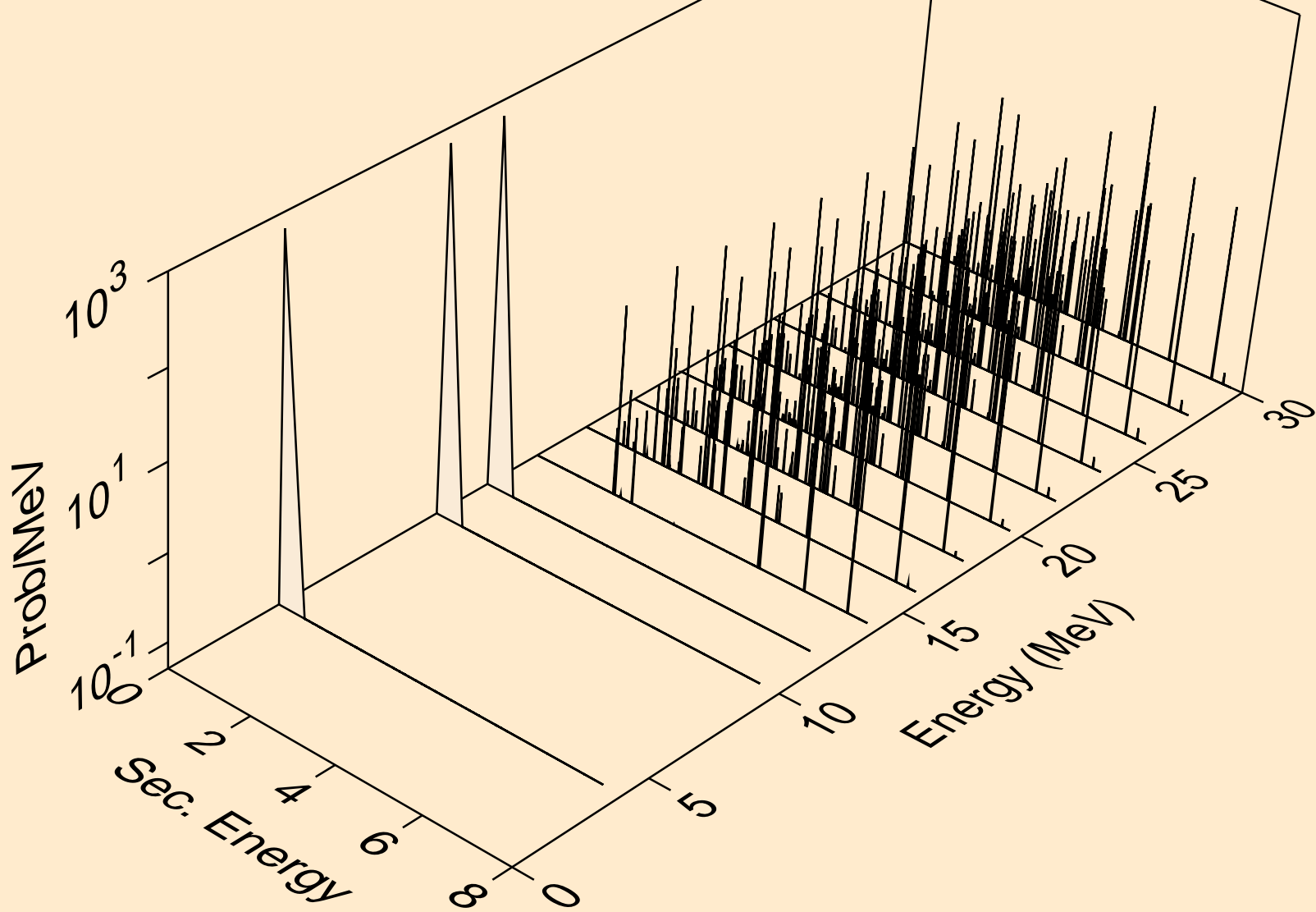

F019 PHOTON ACER TENDL-2024 LIBRARY; T=0.K
photons from (g,2a)

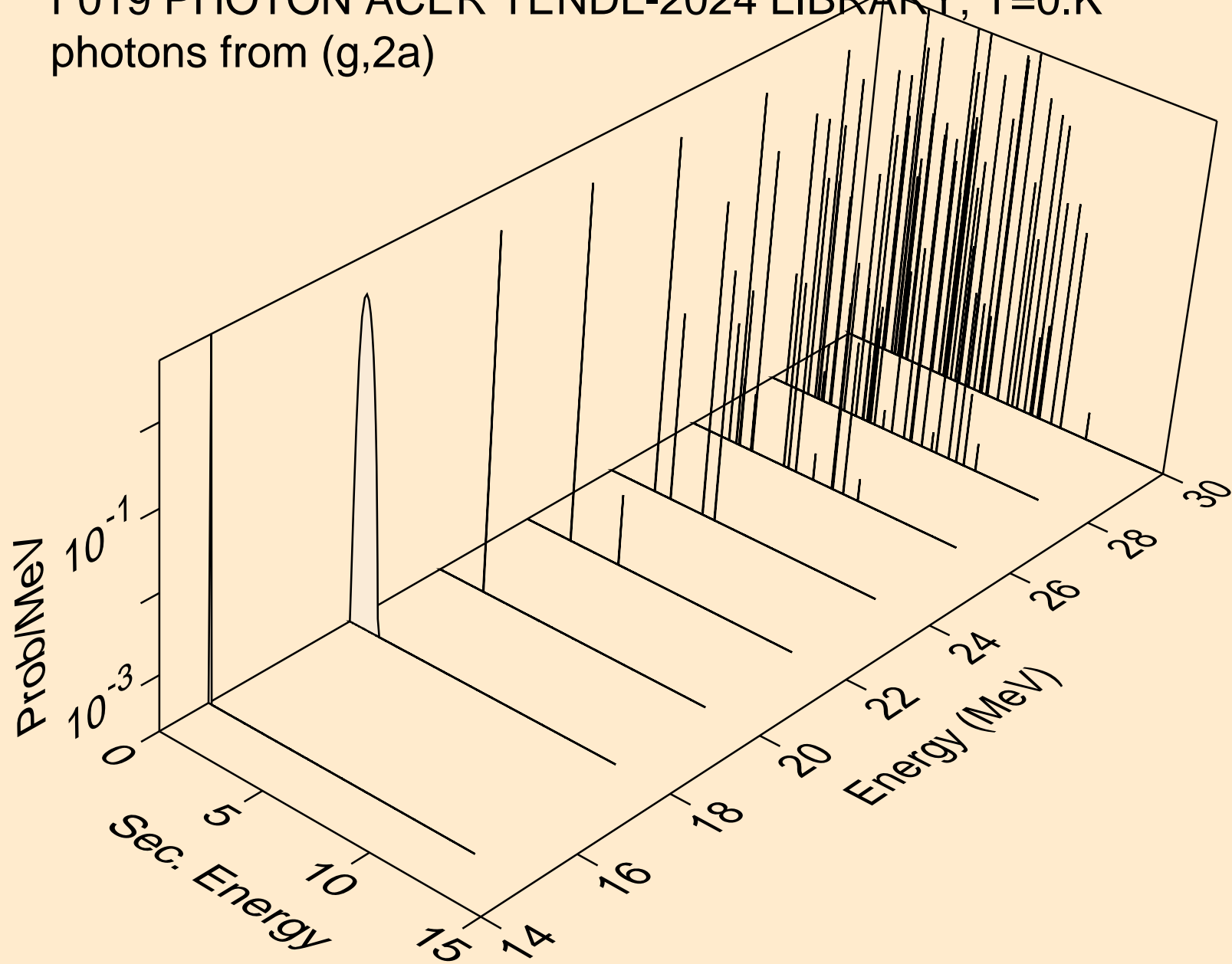

F019 PHOTON ACER TENDL-2024 LIBRARY; T=0.K
photons from (g,2p)

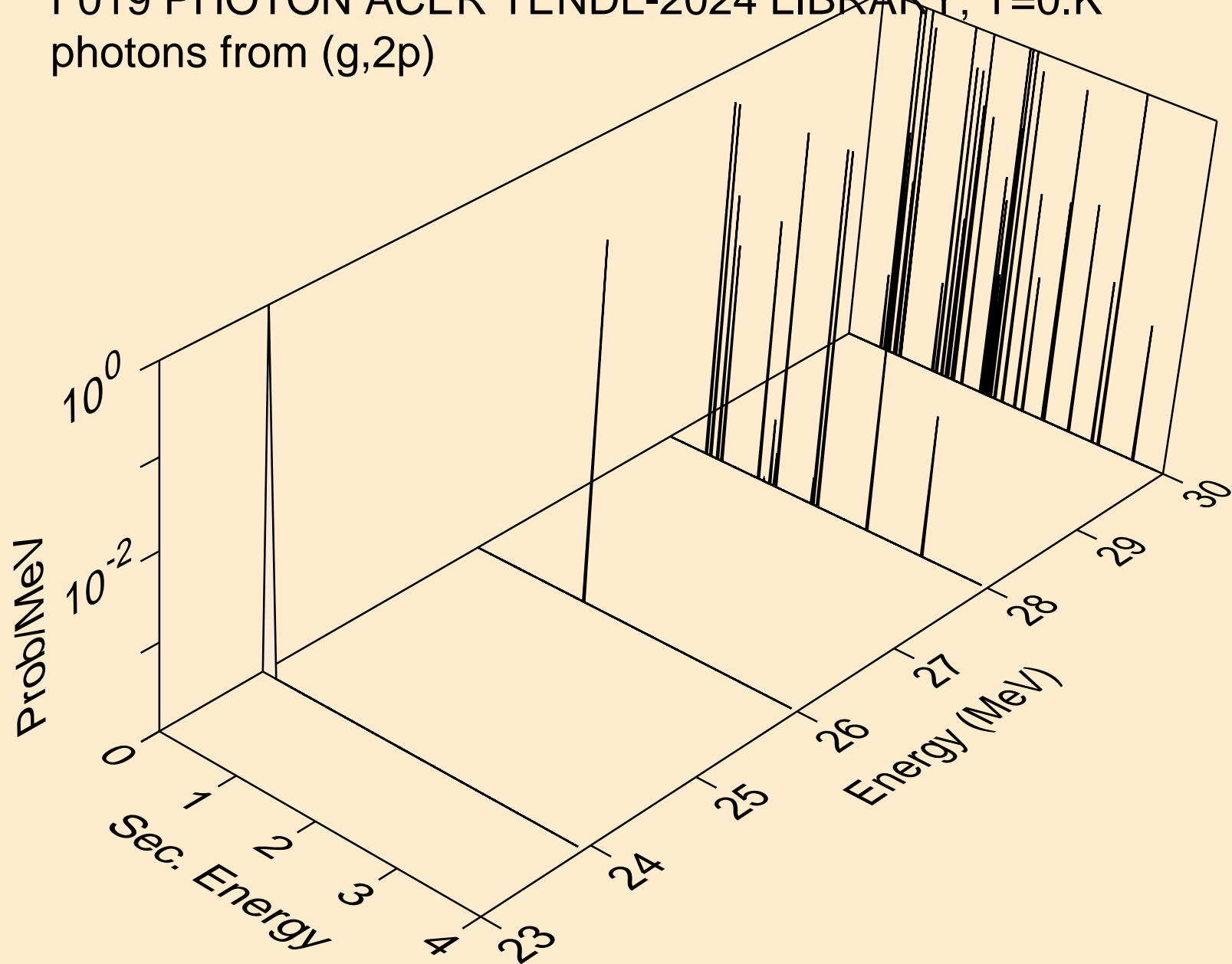

F019 PHOTON ACER TENDL-2024 LIBRARY; T=0.K
photons from (g,pa)

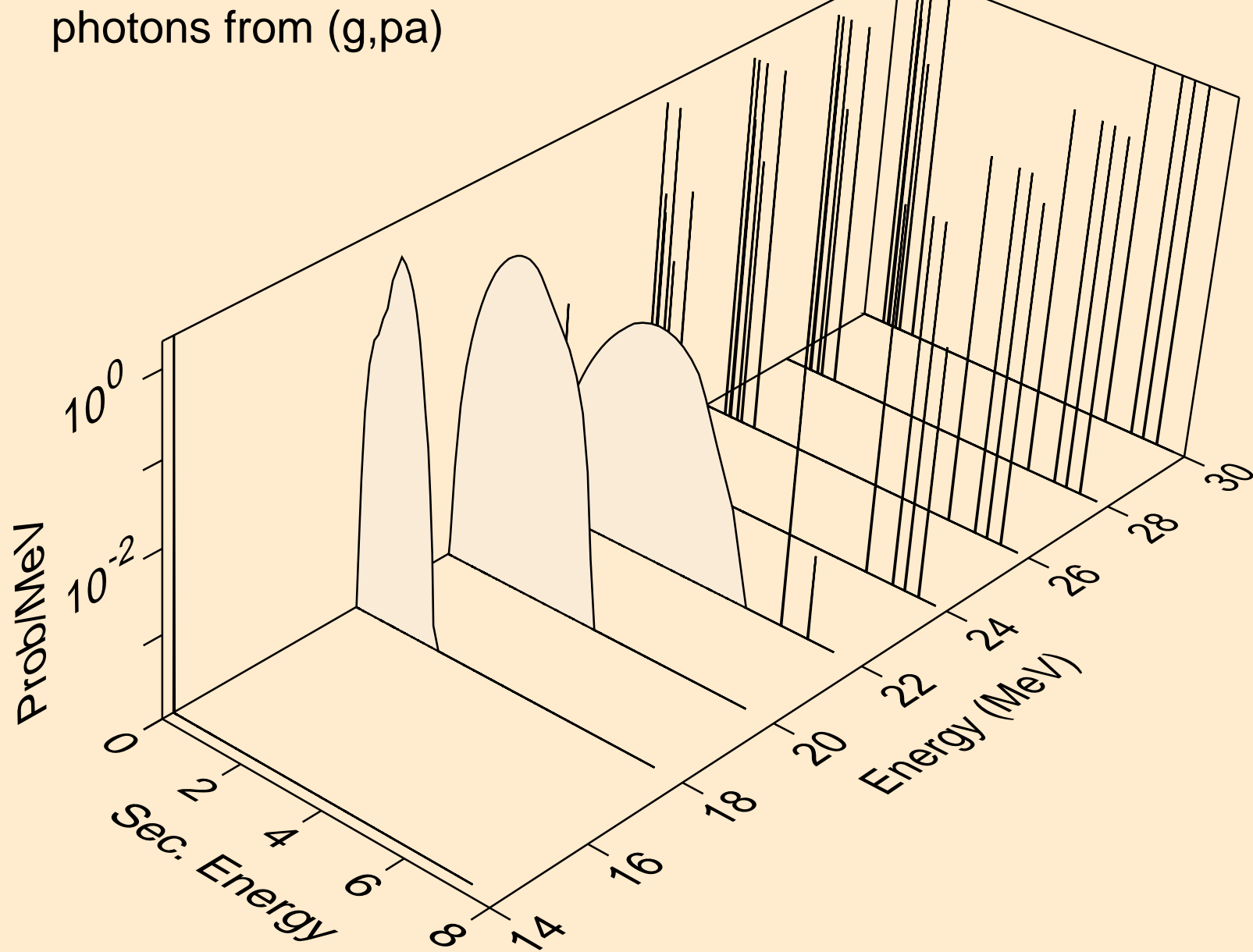

F019 PHOTON ACER TENDL-2024 LIBRARY; T=0.K
photons from (g,pd)

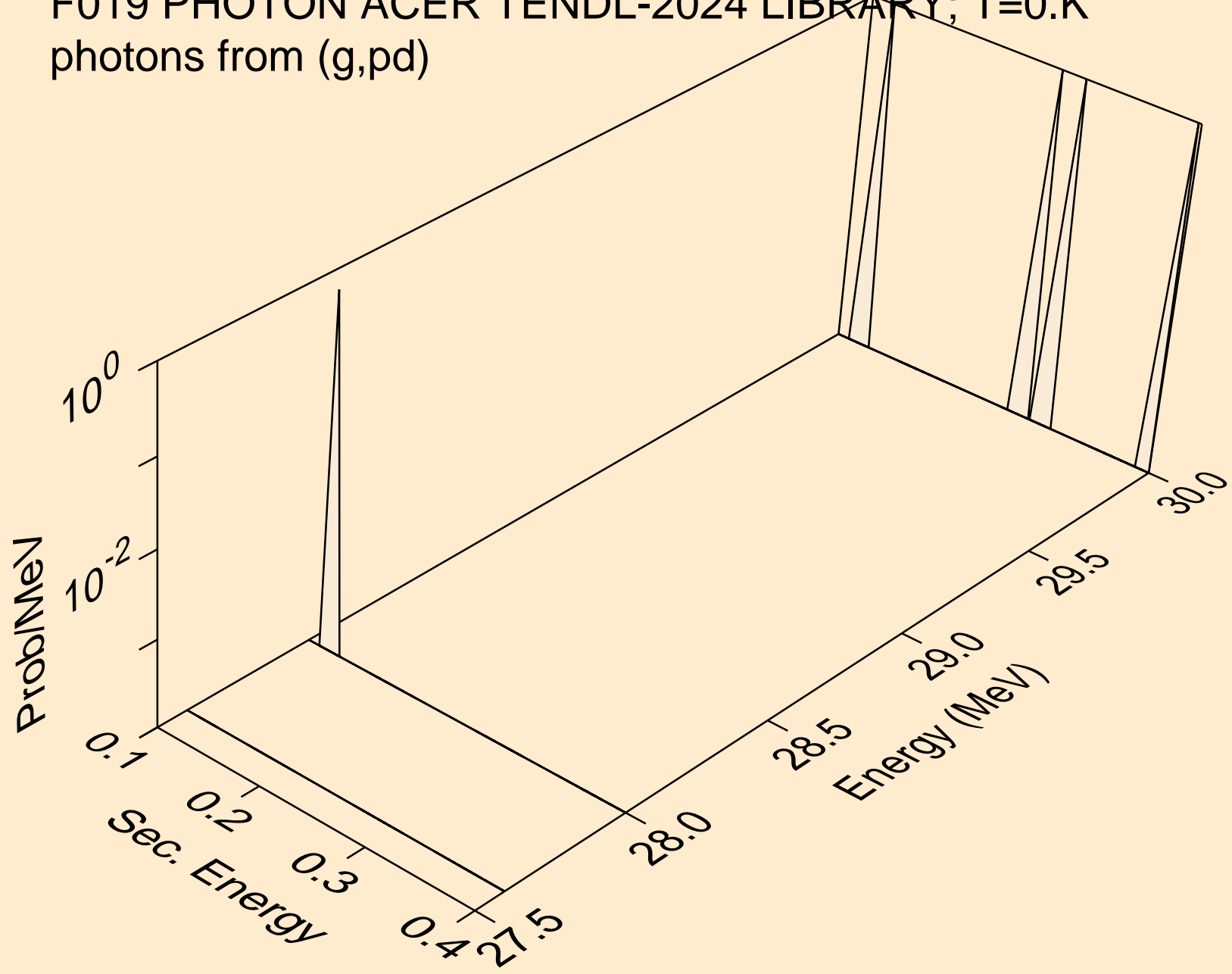

F019 PHOTON ACER TENDL-2024 LIBRARY; T=0.K
photons from (g,pt)

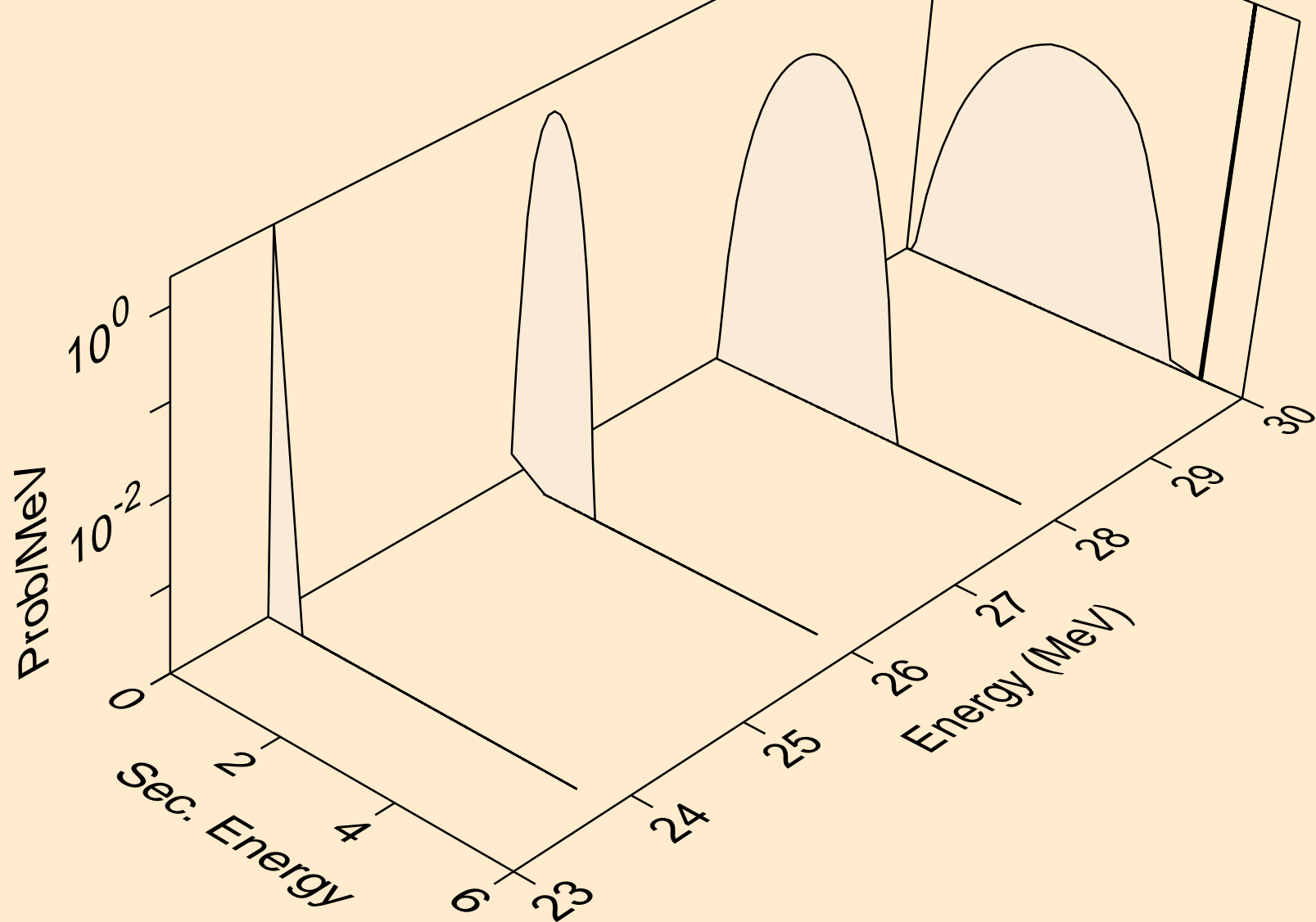

F019 PHOTON ACER TENDL-2024 LIBRARY; T=0.K
photons from (g,da)

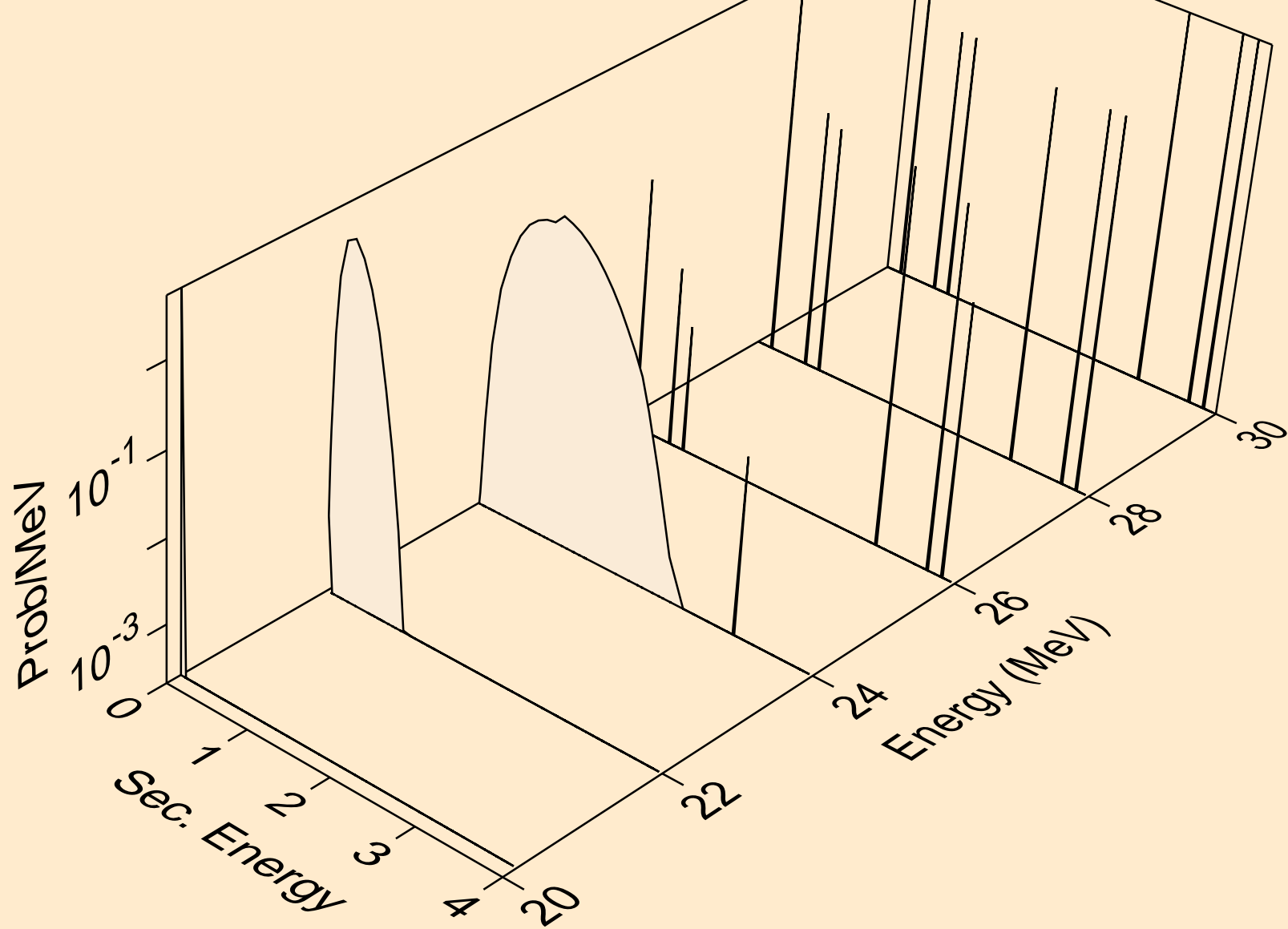

F019 PHOTON ACER TENDL-2024 LIBRARY; T=0.K
protons from (g,x)

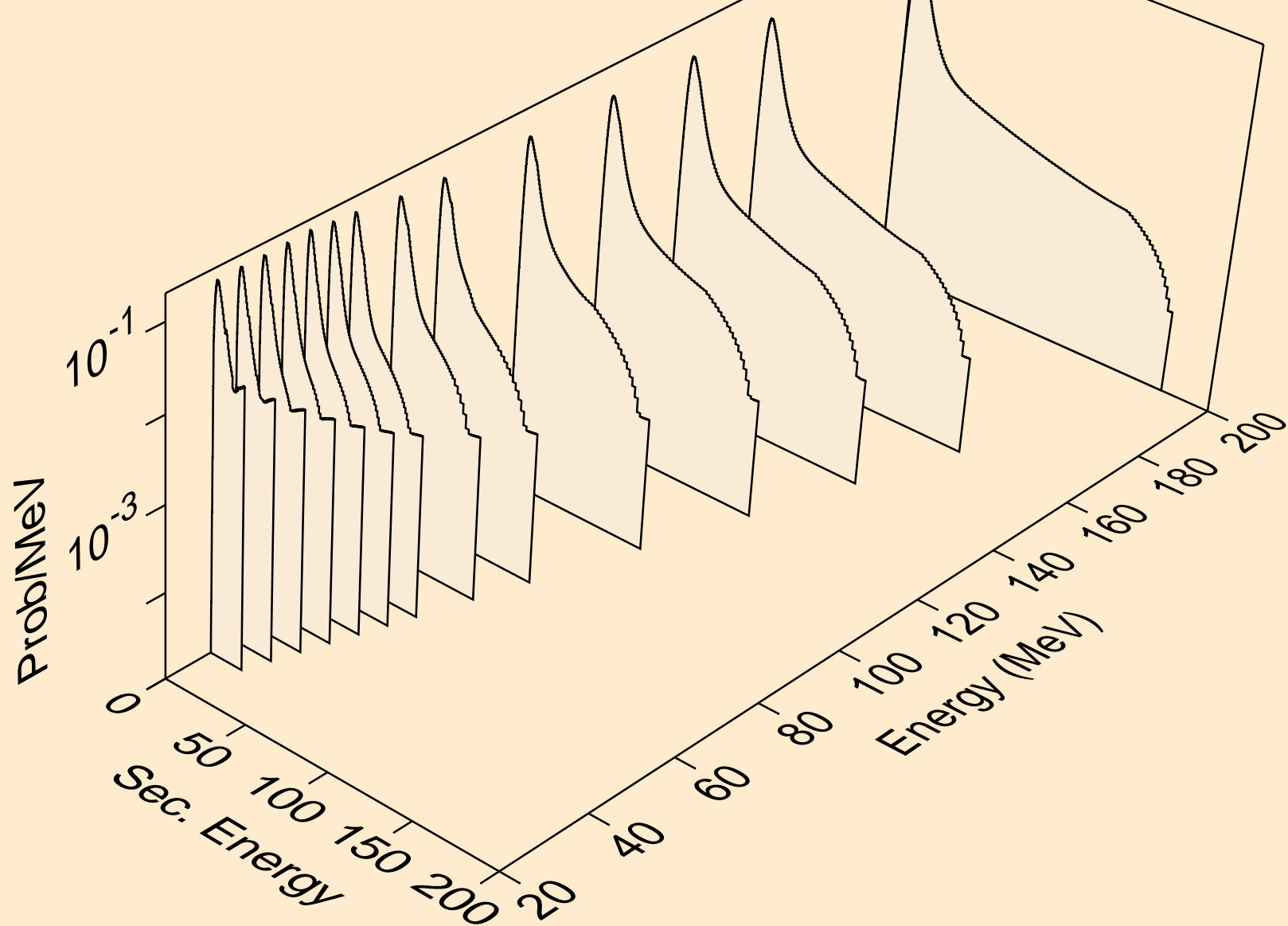

F019 PHOTON ACER TENDL-2024 LIBRARY; T=0.K
protons from (g,n*)p

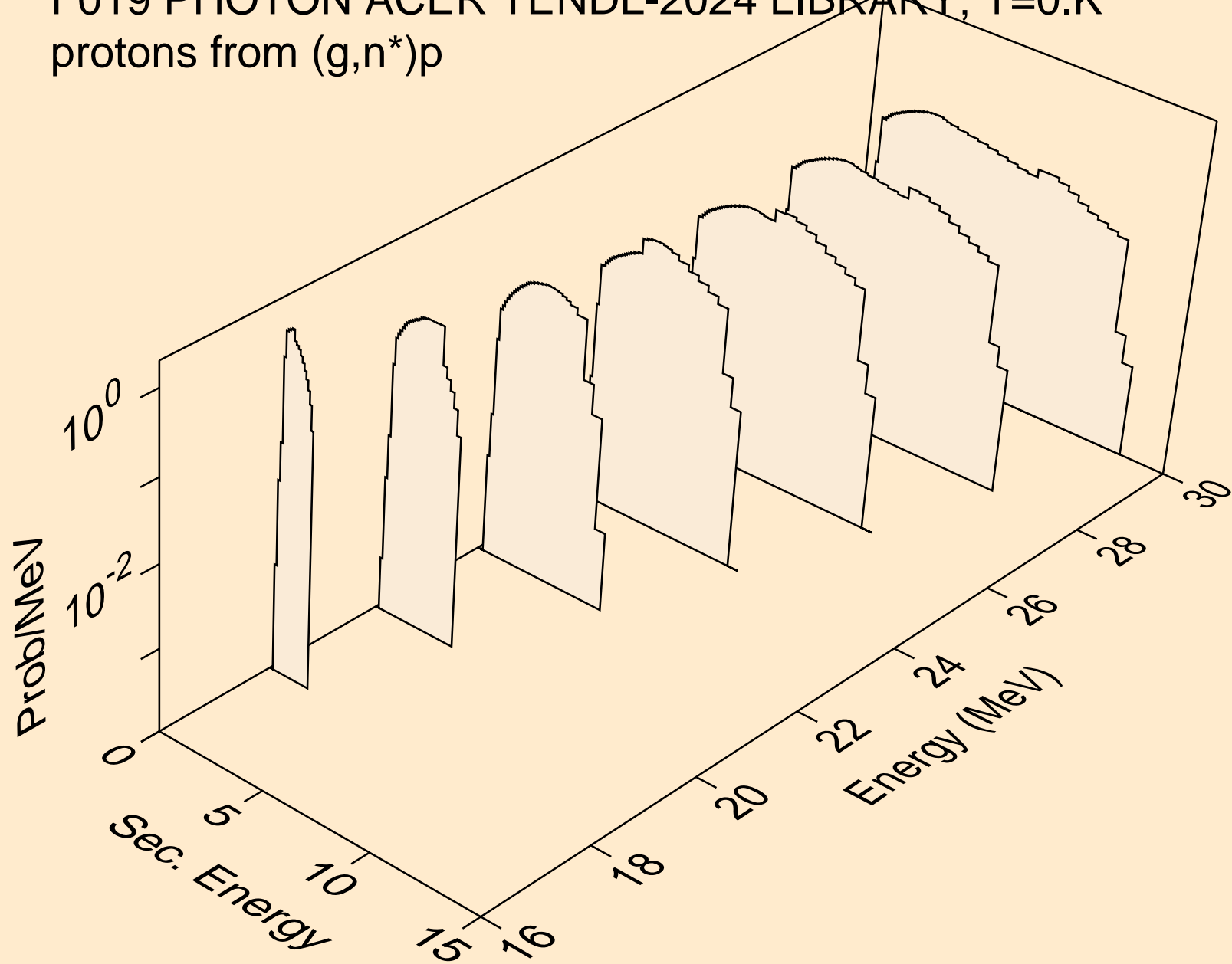

F019 PHOTON ACER TENDL-2024 LIBRARY; T=0.K
protons from (g,2np)

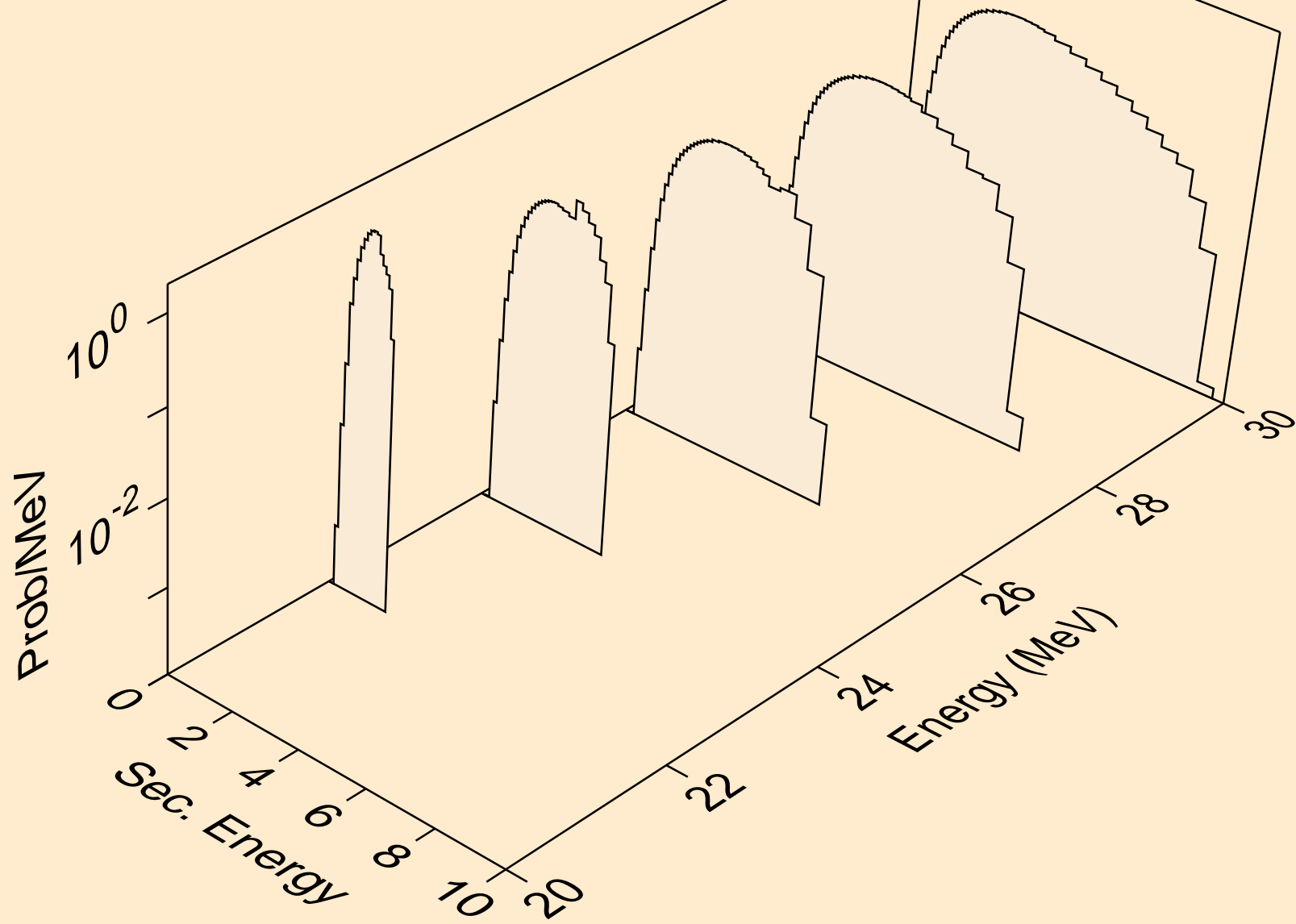

F019 PHOTON ACER TENDL-2024 LIBRARY; T=0.K
protons from (g,npa)

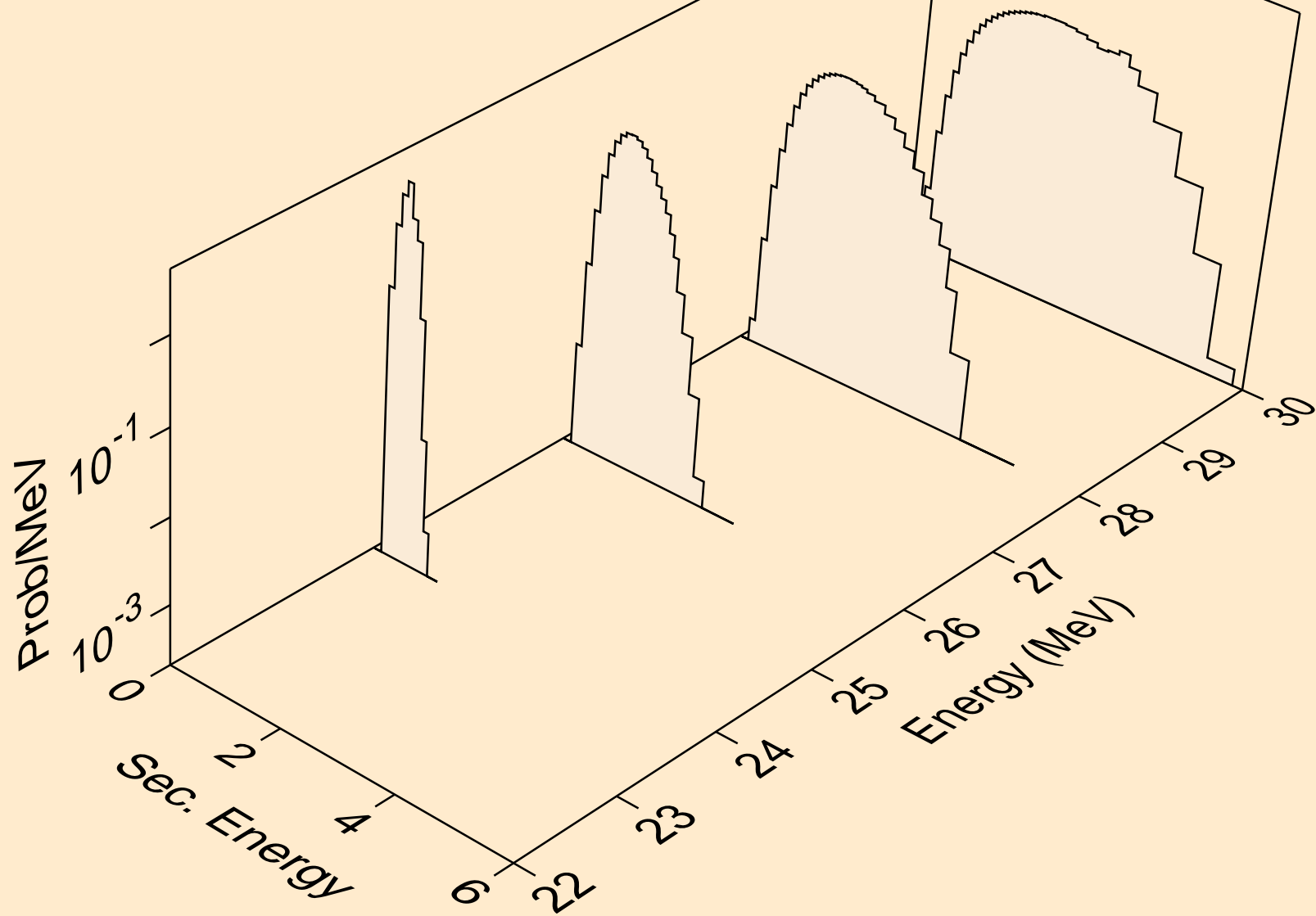

F019 PHOTON ACER TENDL-2024 LIBRARY; T=0.K
protons from (g,p)

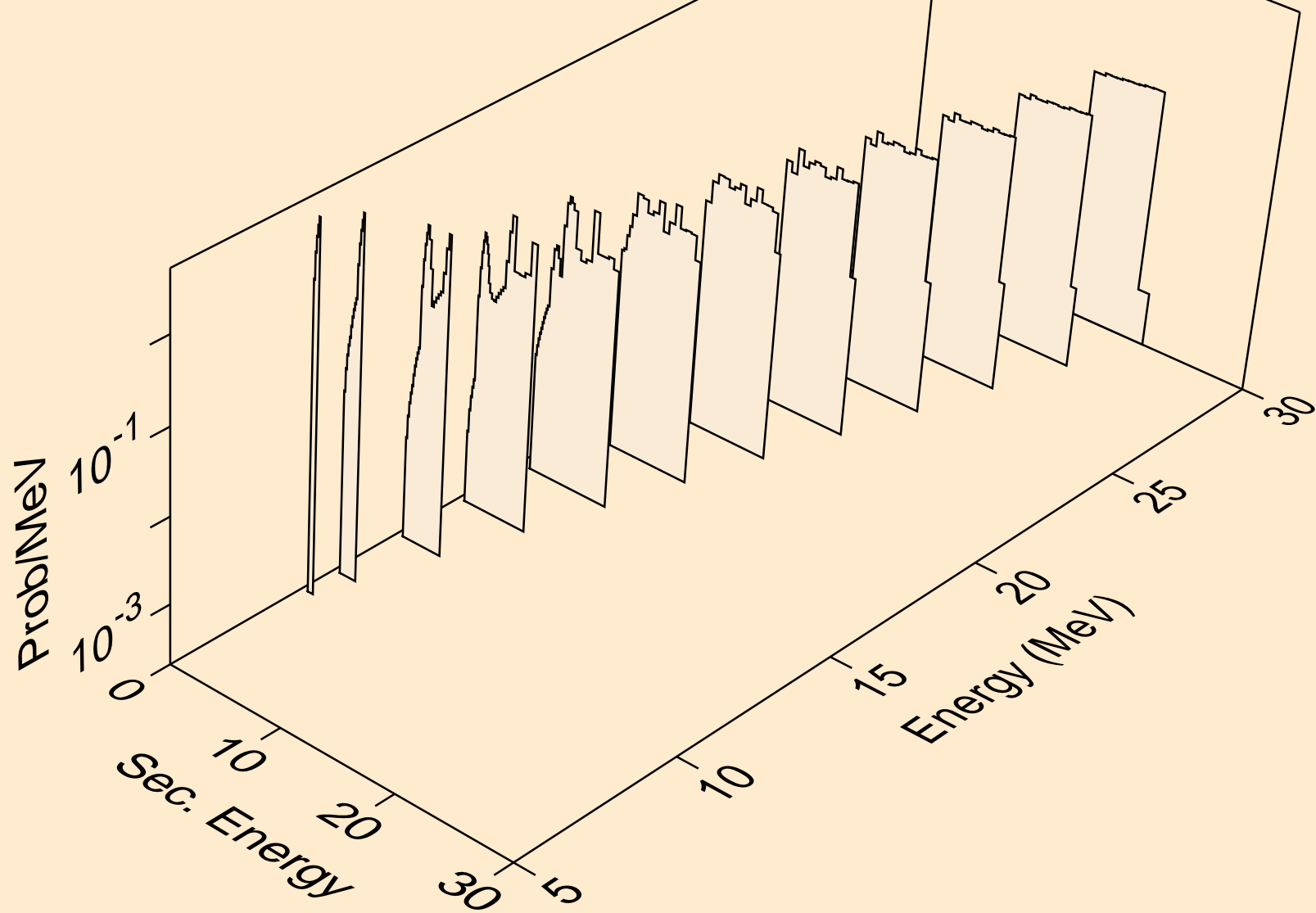

F019 PHOTON ACER TENDL-2024 LIBRARY; T=0.K
protons from (g,2p)

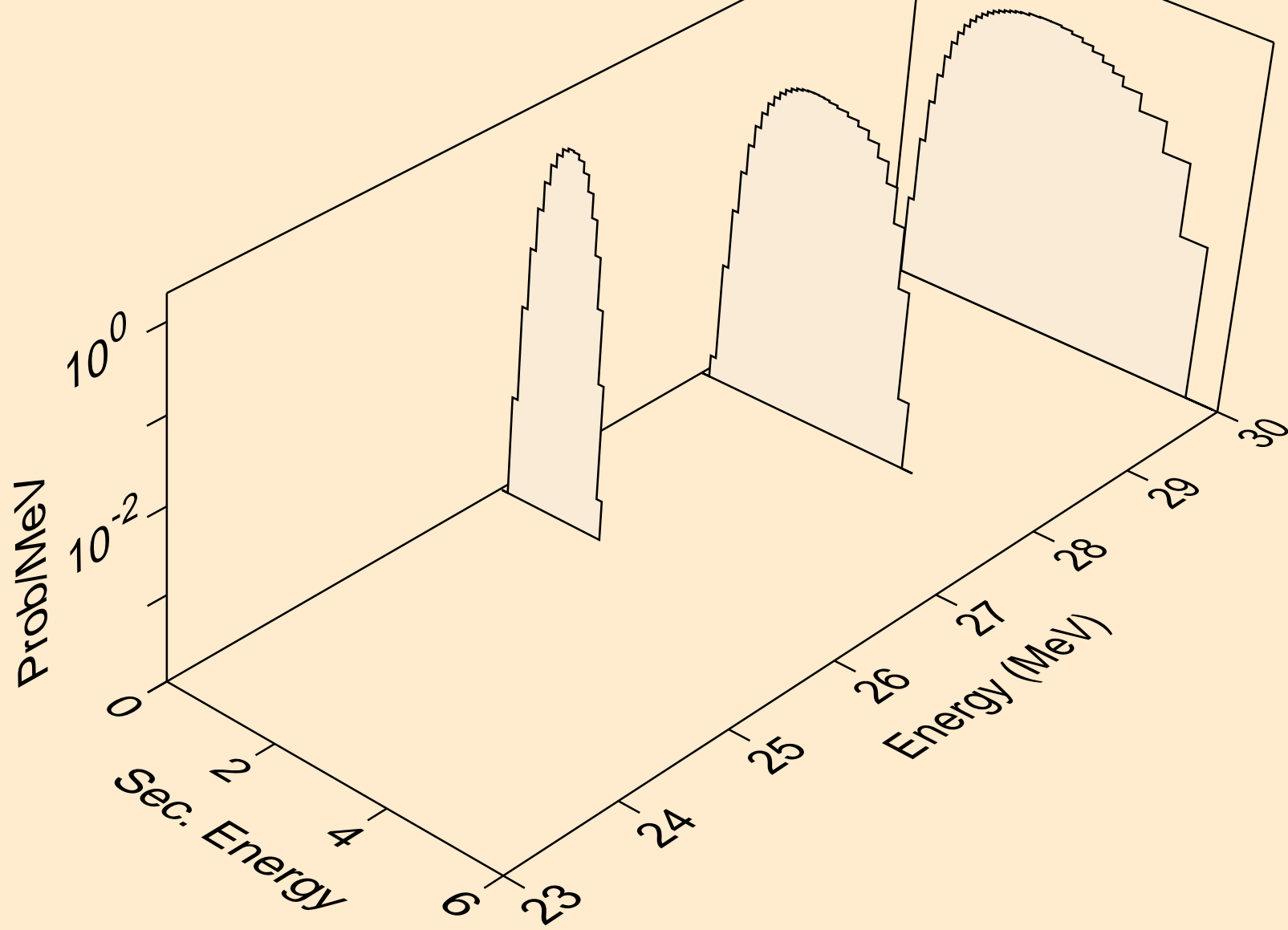

F019 PHOTON ACER TENDL-2024 LIBRARY; T=0.K
protons from (g,pa)

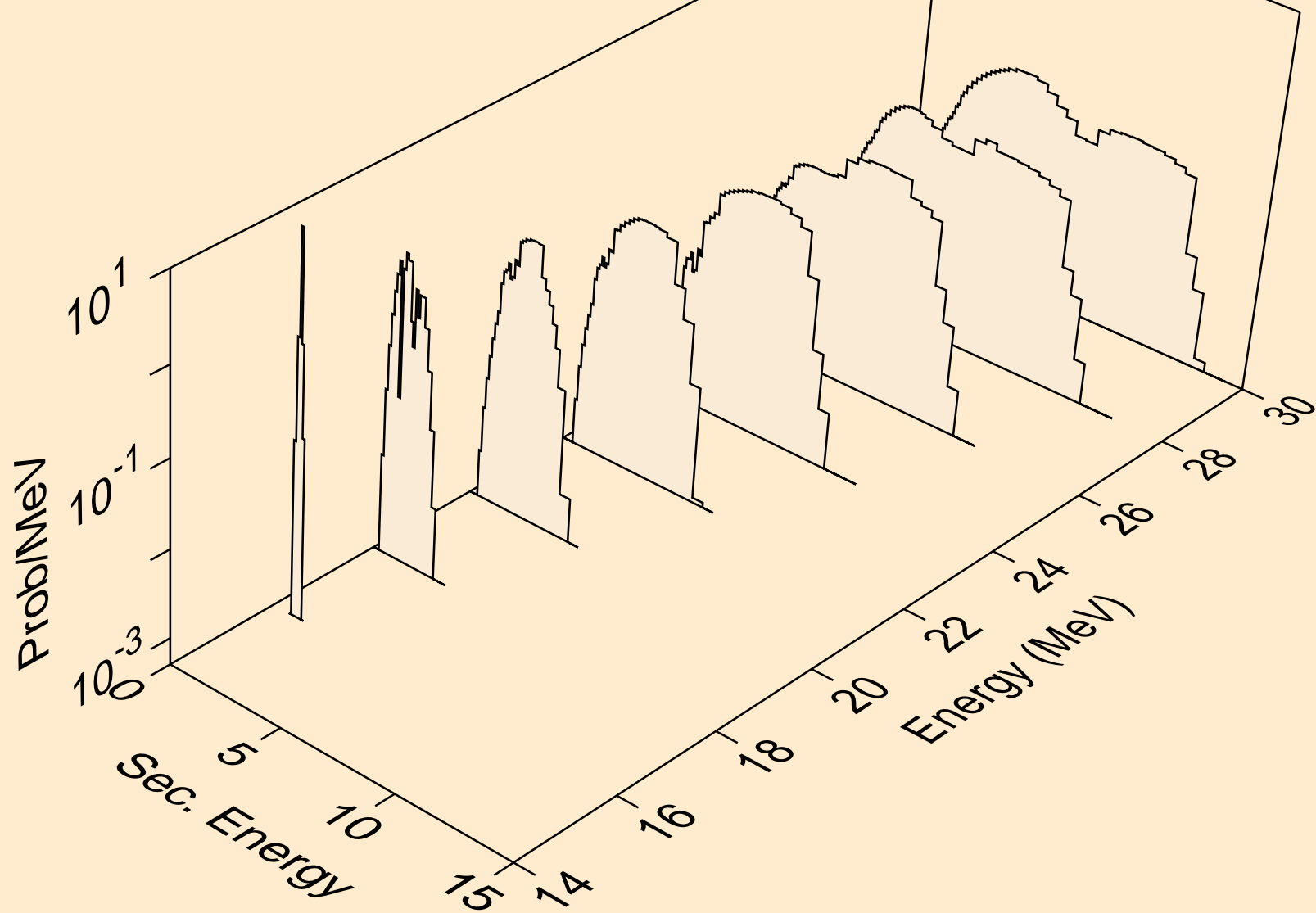

F019 PHOTON ACER TENDL-2024 LIBRARY; T=0.K
protons from (g,pd)

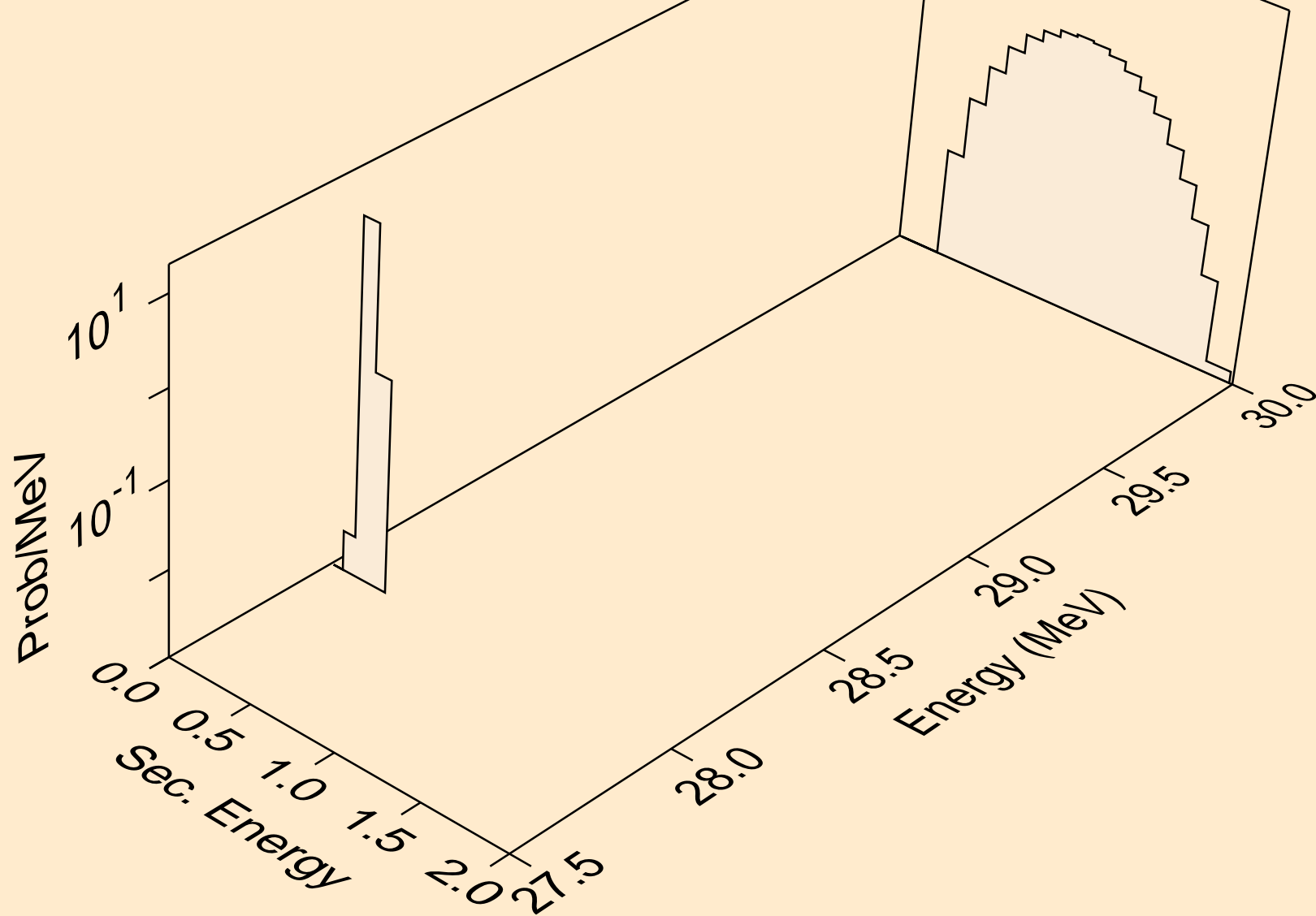

F019 PHOTON ACER TENDL-2024 LIBRARY; T=0.K
protons from (g,pt)

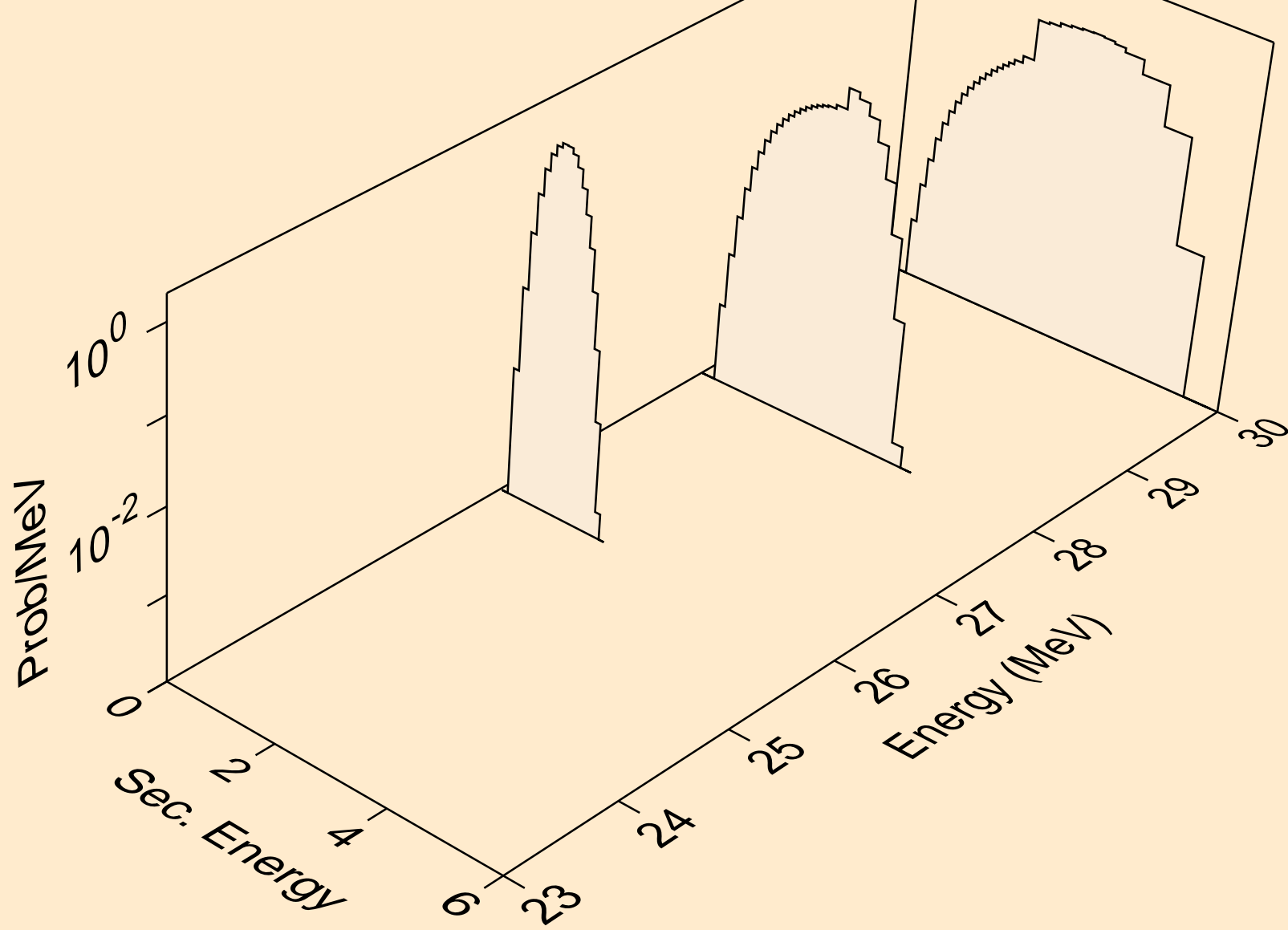

F019 PHOTON ACER TENDL-2024 LIBRARY; T=0.K
deuterons from (g,x)

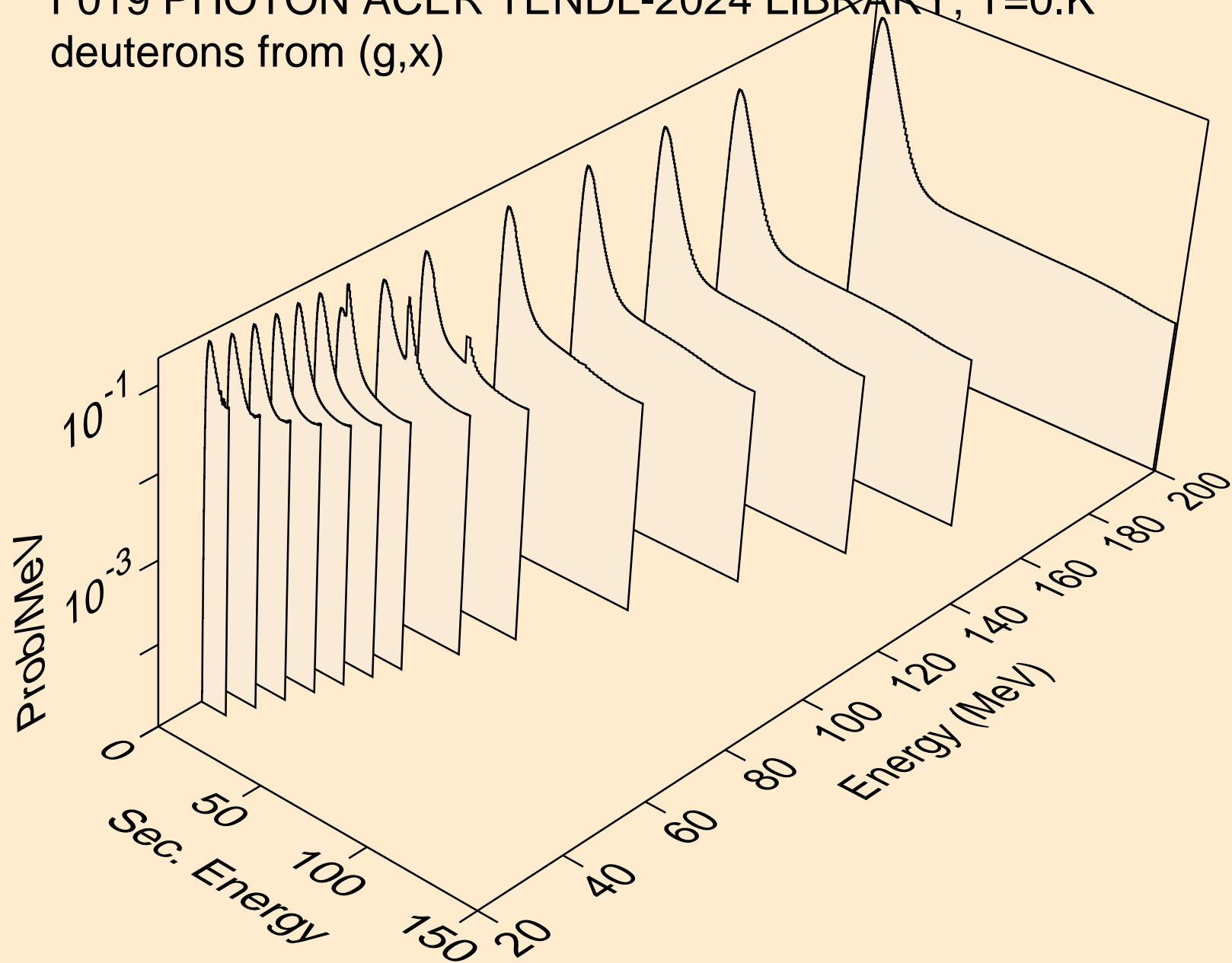

F019 PHOTON ACER TENDL-2024 LIBRARY; T=0.K
deuterons from (g,n*)d

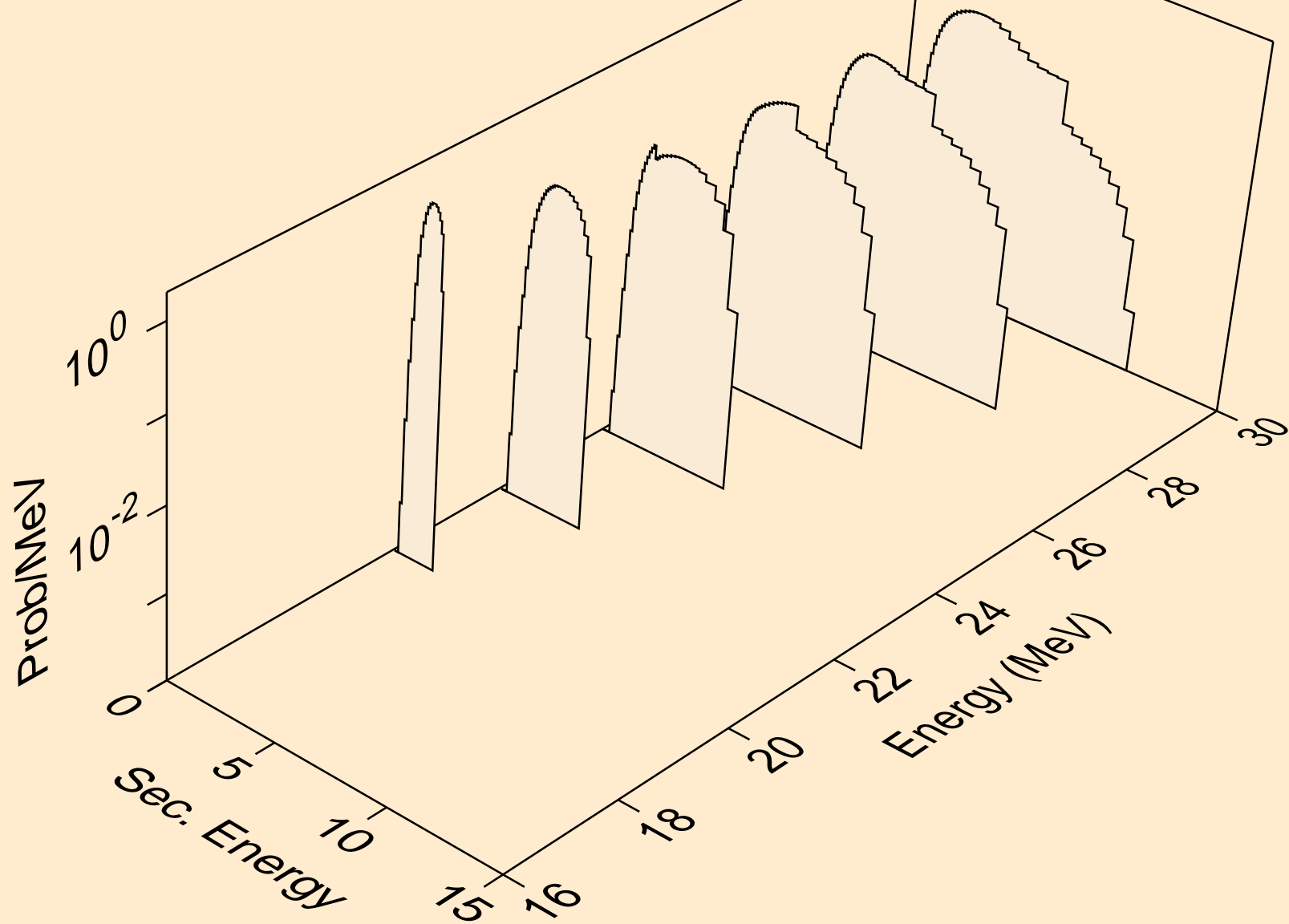

F019 PHOTON ACER TENDL-2024 LIBRARY; T=0.K
deuterons from (g,d)

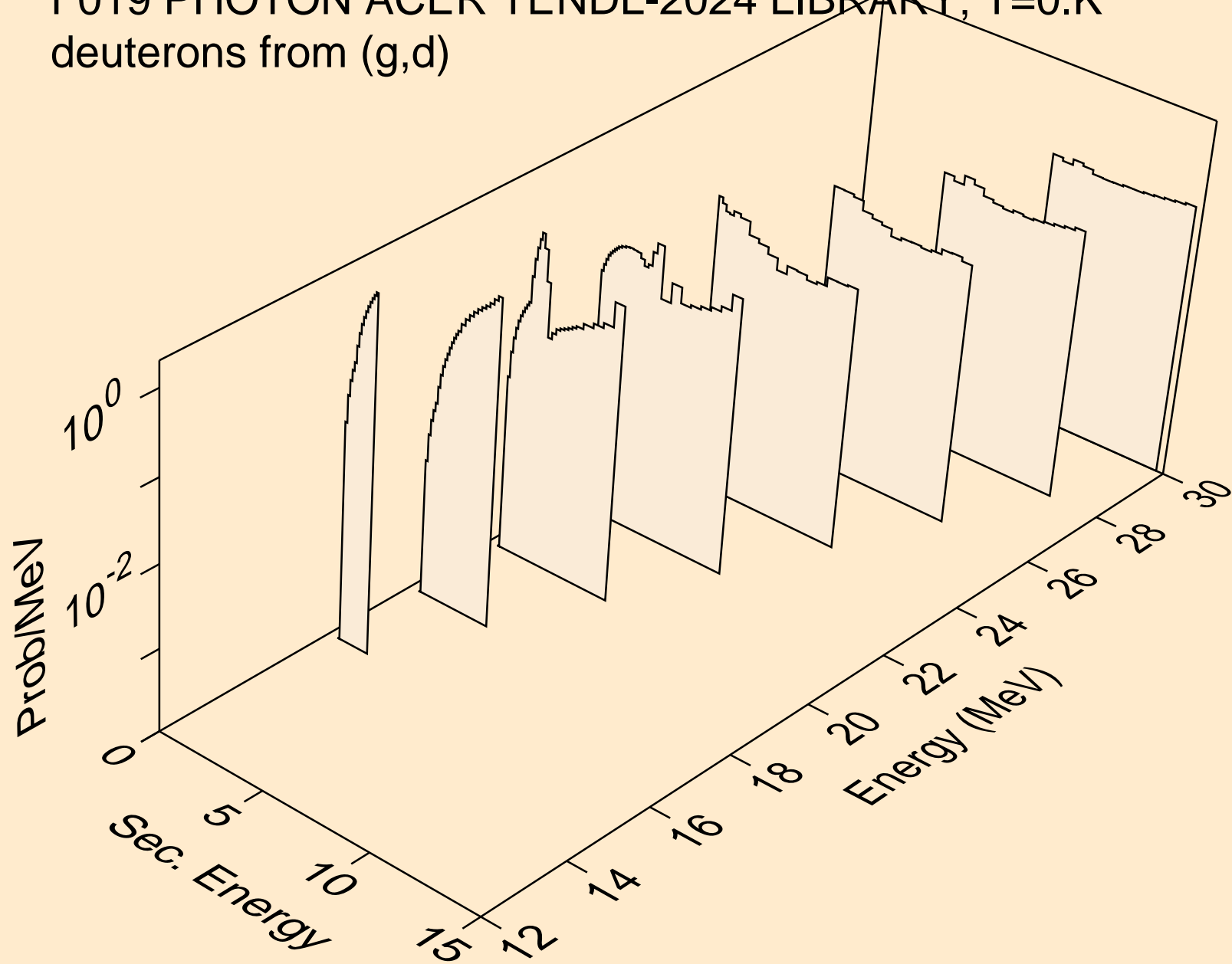

F019 PHOTON ACER TENDL-2024 LIBRARY; T=0.K
deuterons from (g,pd)

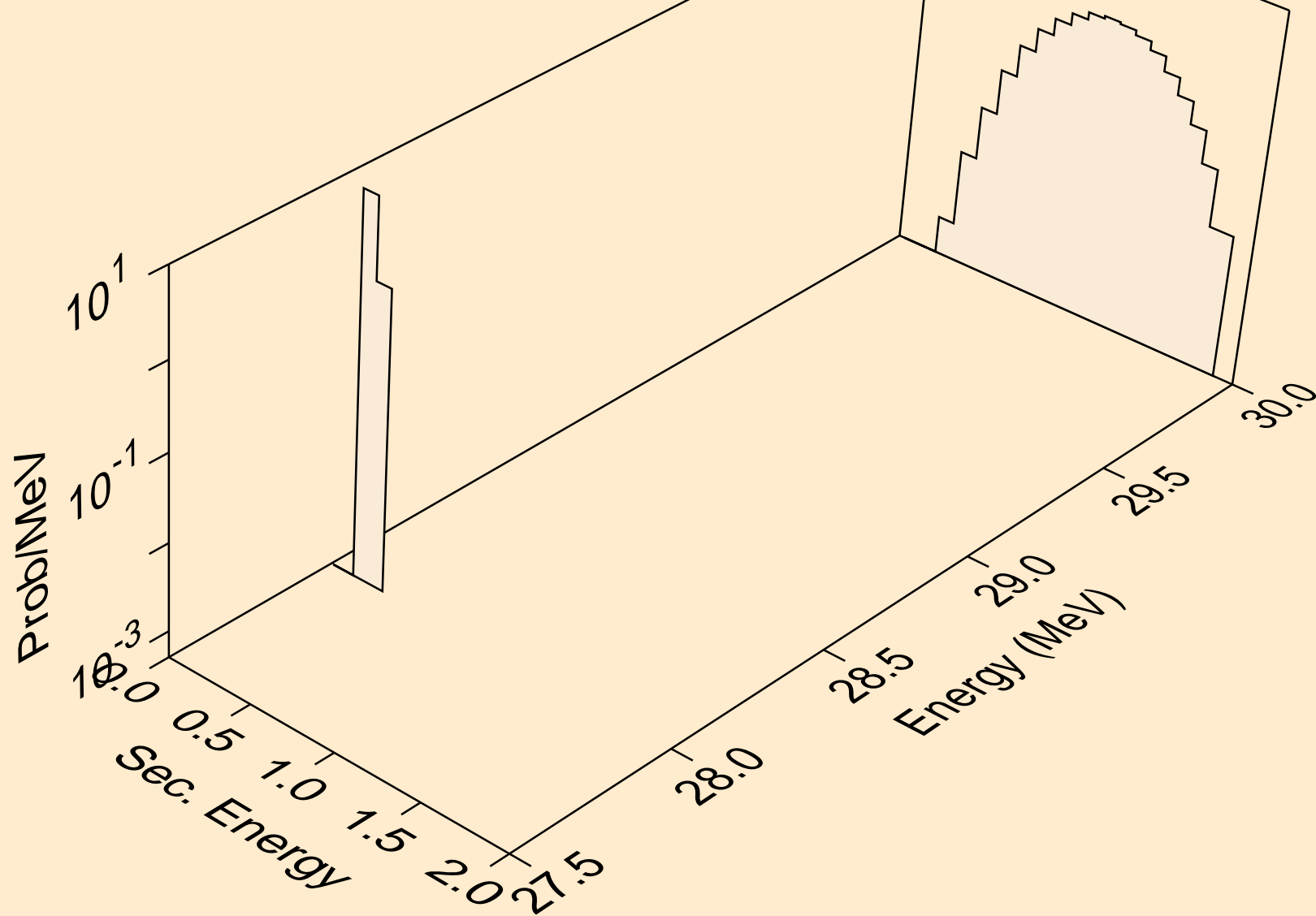

F019 PHOTON ACER TENDL-2024 LIBRARY; T=0.K
deuterons from (g,da)

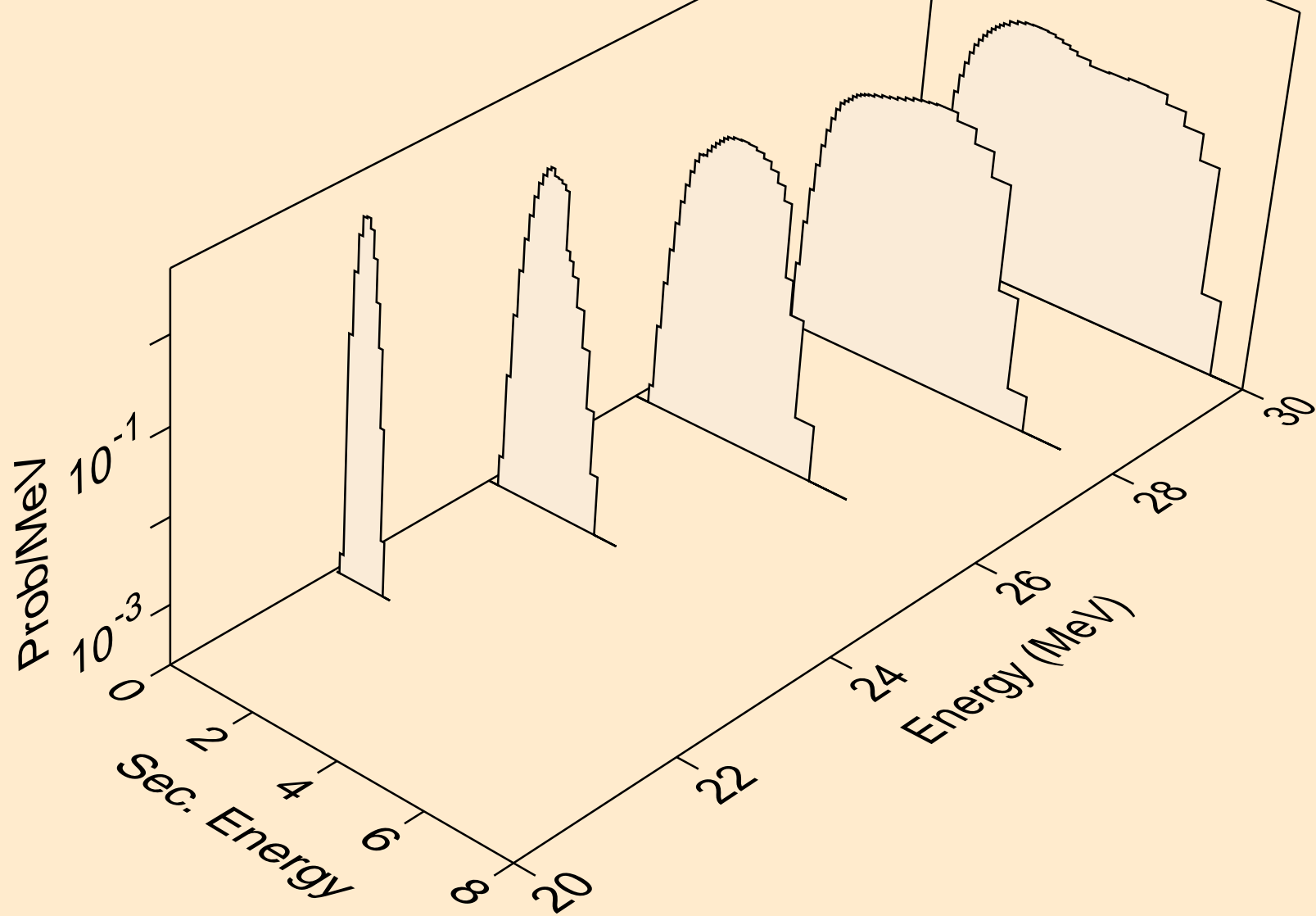

F019 PHOTON ACER TENDL-2024 LIBRARY; T=0.K
tritons from (g,x)

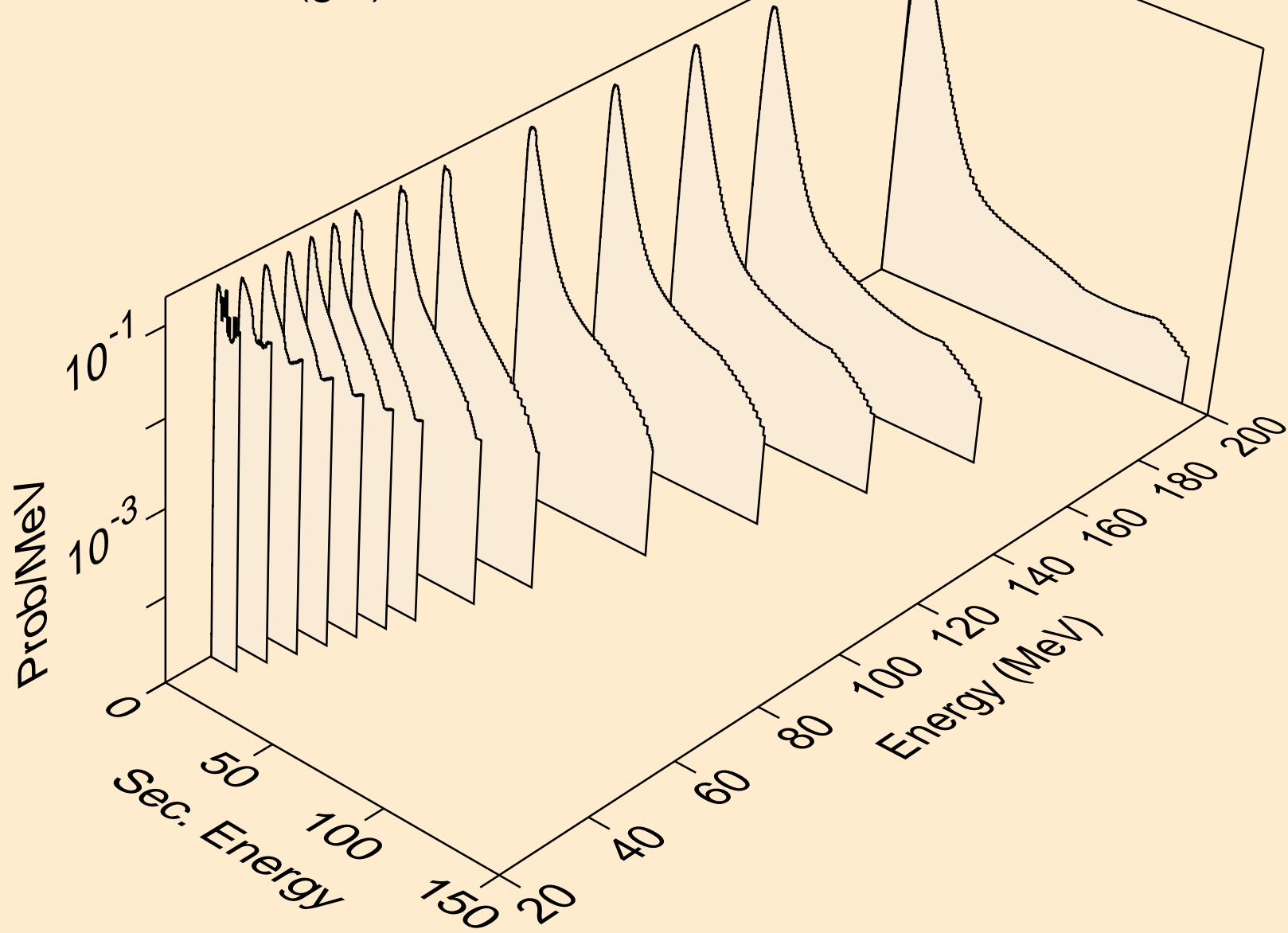

F019 PHOTON ACER TENDL-2024 LIBRARY; T=0.K
tritons from (g,n*)t

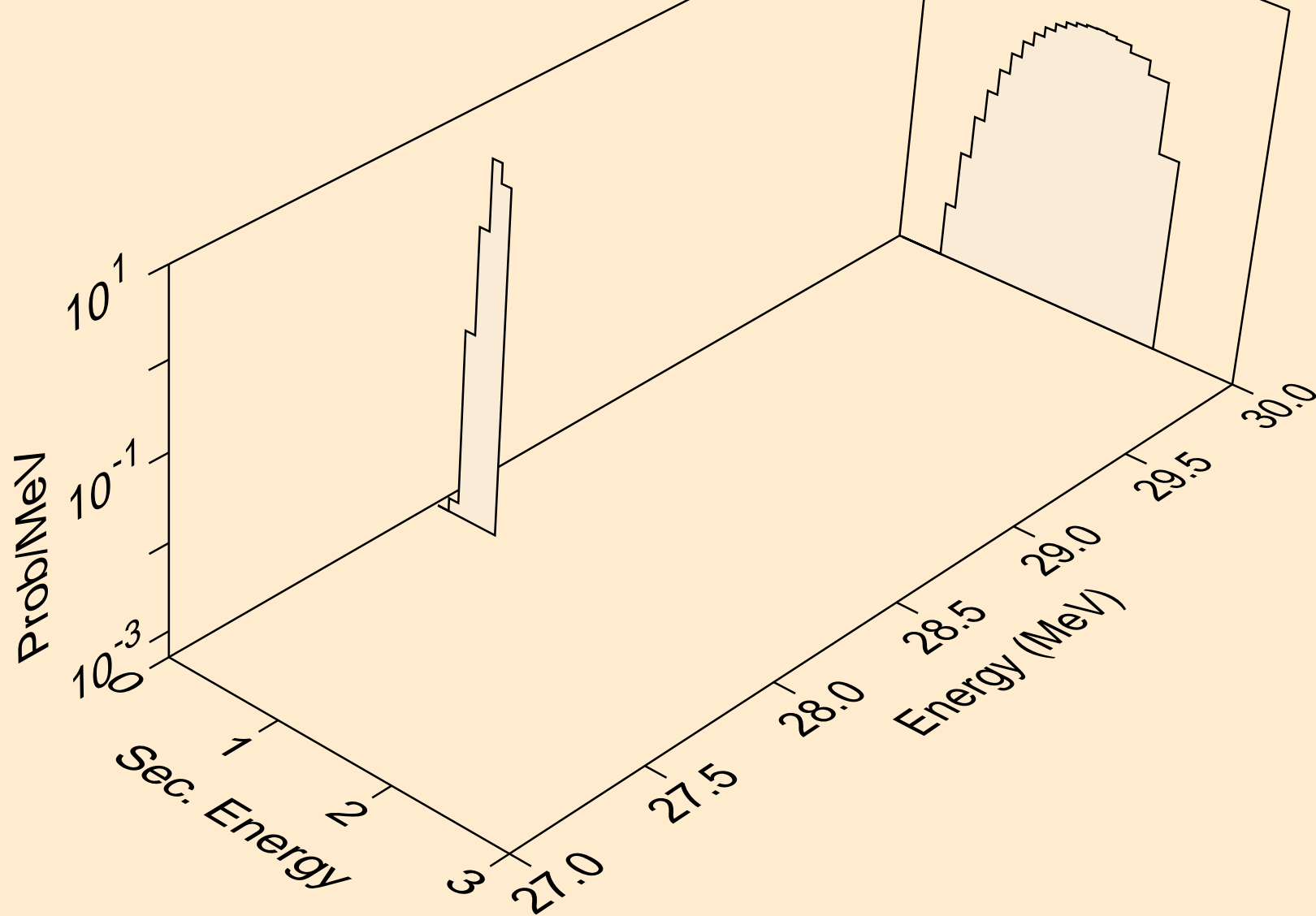

F019 PHOTON ACER TENDL-2024 LIBRARY; T=0.K
tritons from (g,t)

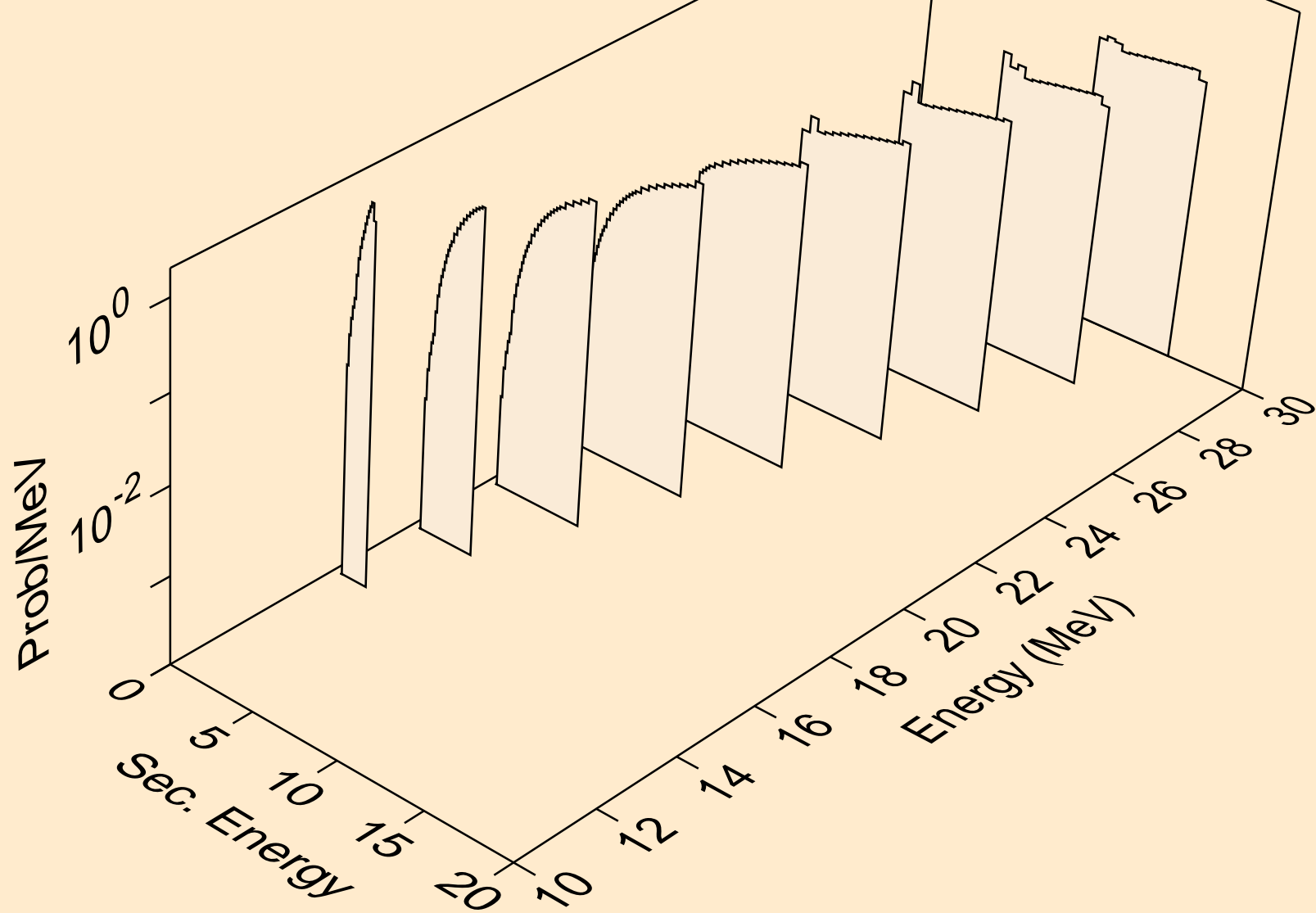

F019 PHOTON ACER TENDL-2024 LIBRARY; T=0.K
tritons from (g,pt)

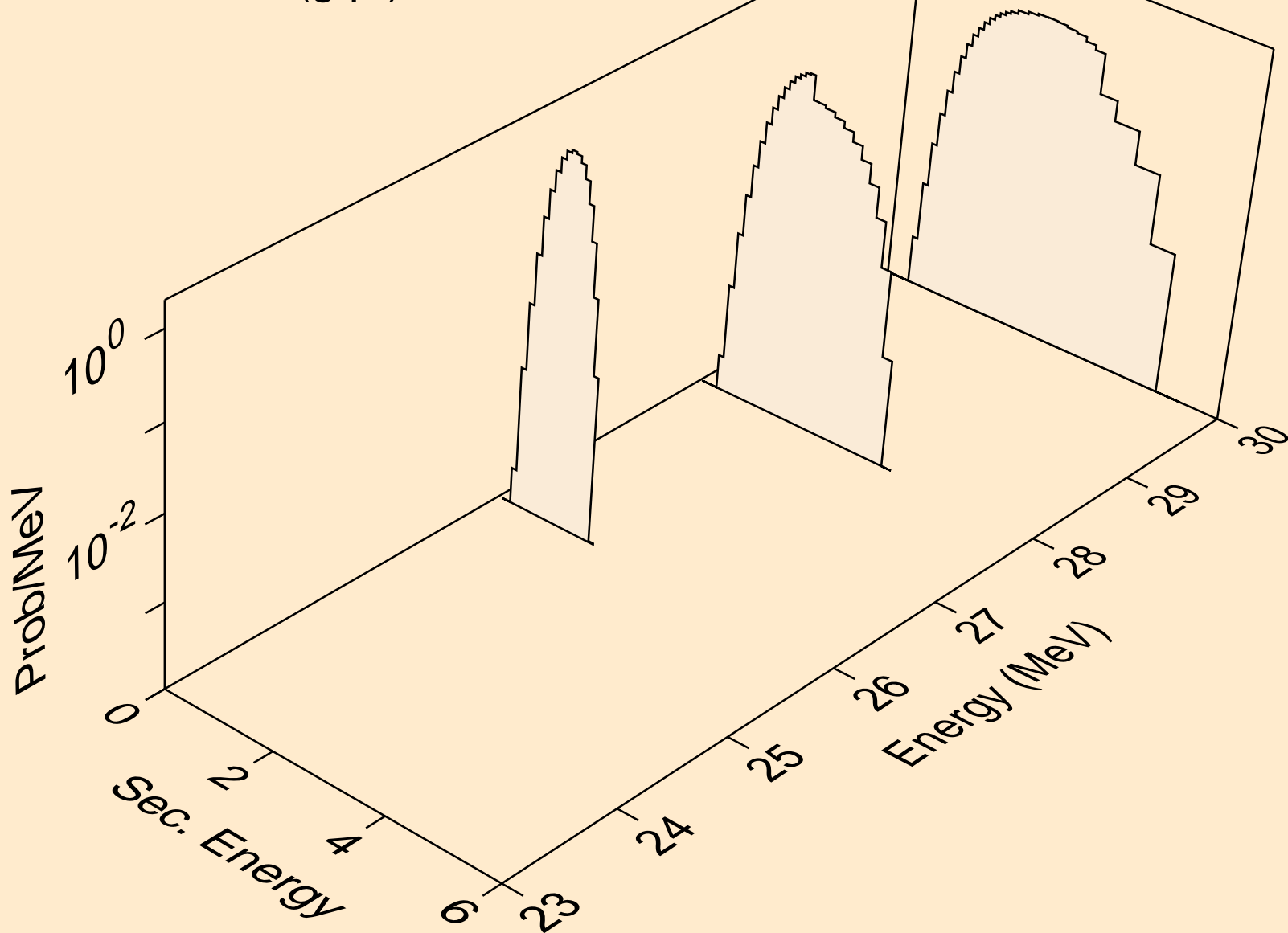

F019 PHOTON ACER TENDL-2024 LIBRARY; T=0.K
he3s from (g,x)

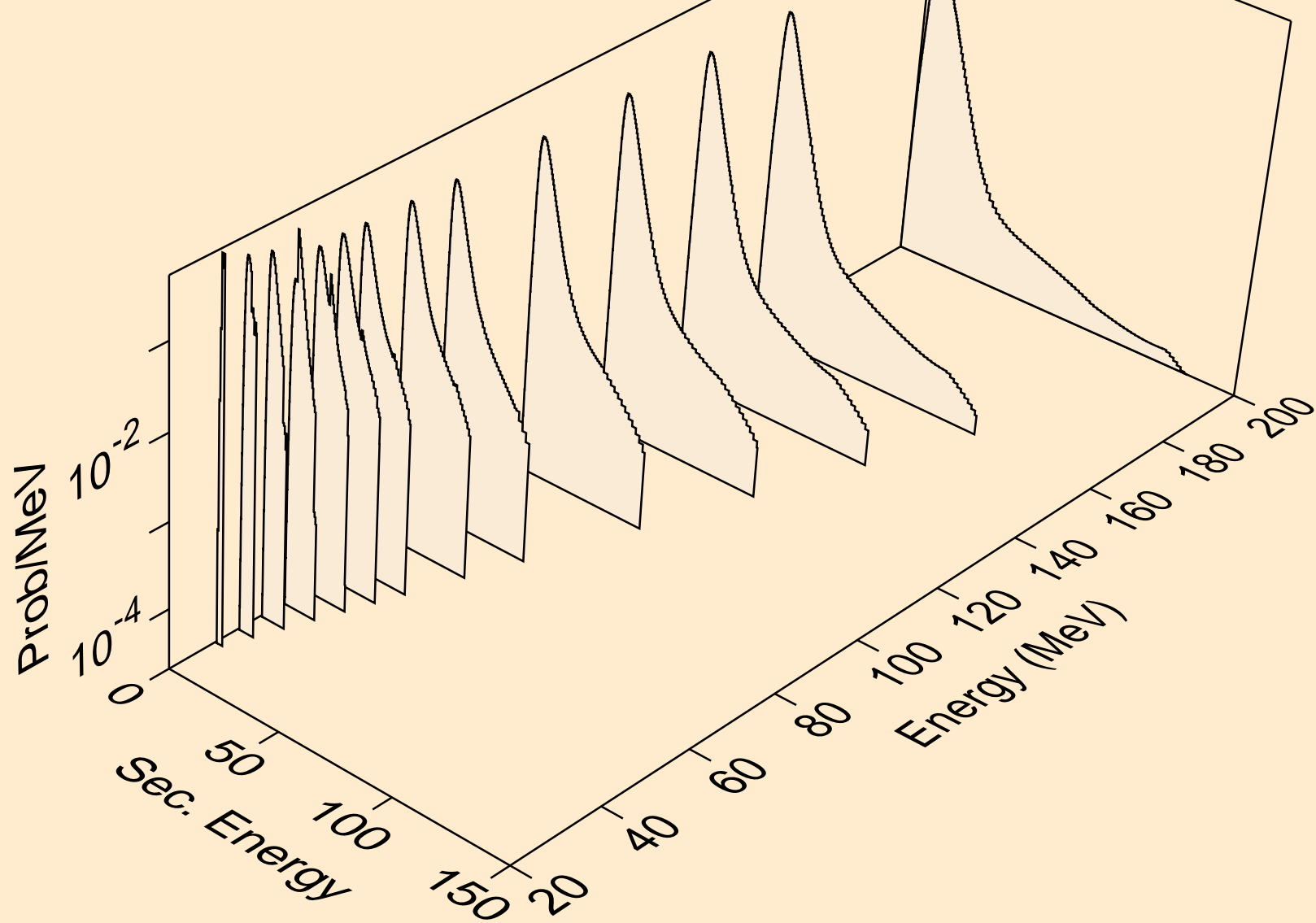

F019 PHOTON ACER TENDL-2024 LIBRARY; T=0.K
he3s from (g,n*)he3

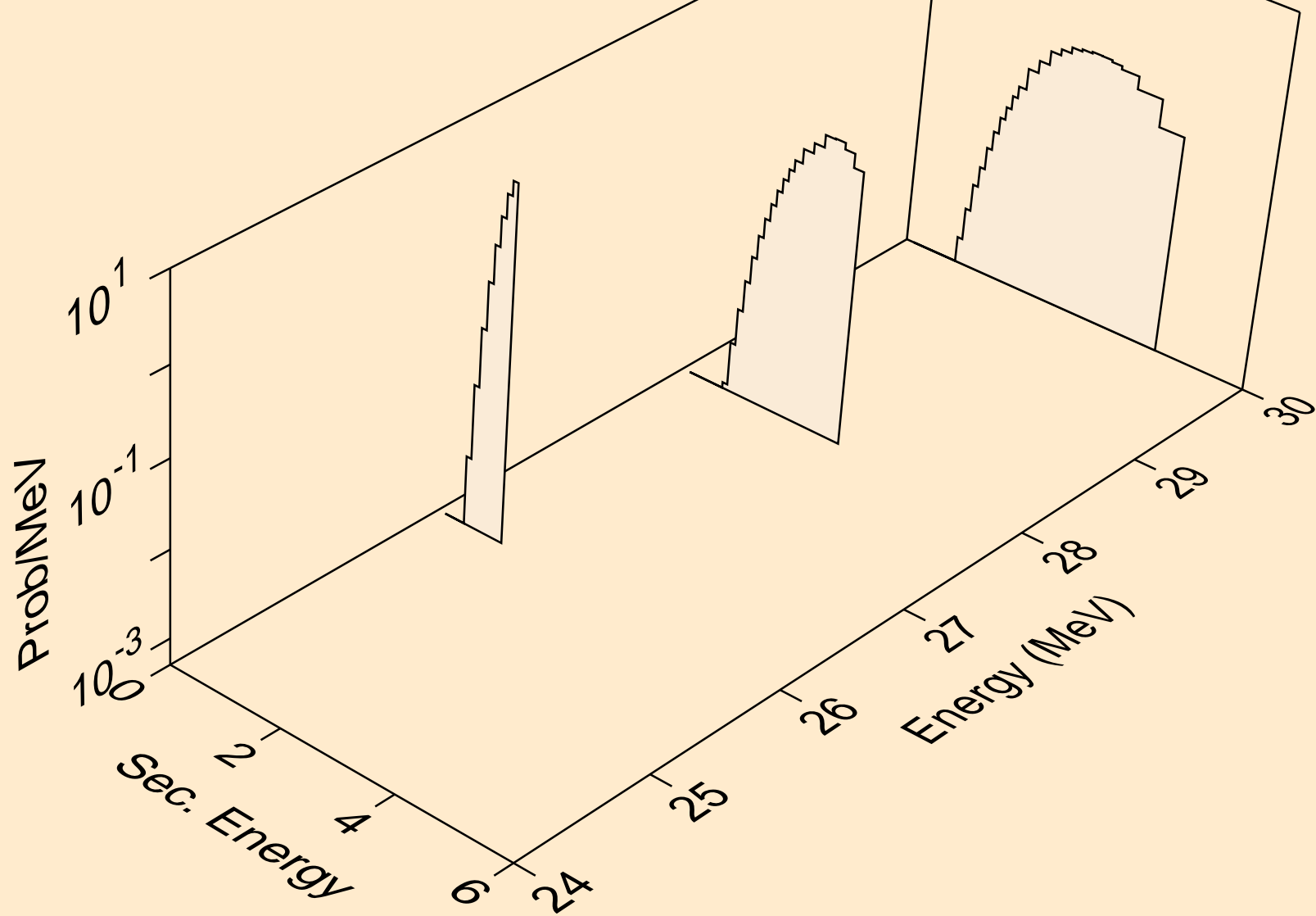

F019 PHOTON ACER TENDL-2024 LIBRARY; T=0.K
he3s from (g,he3)

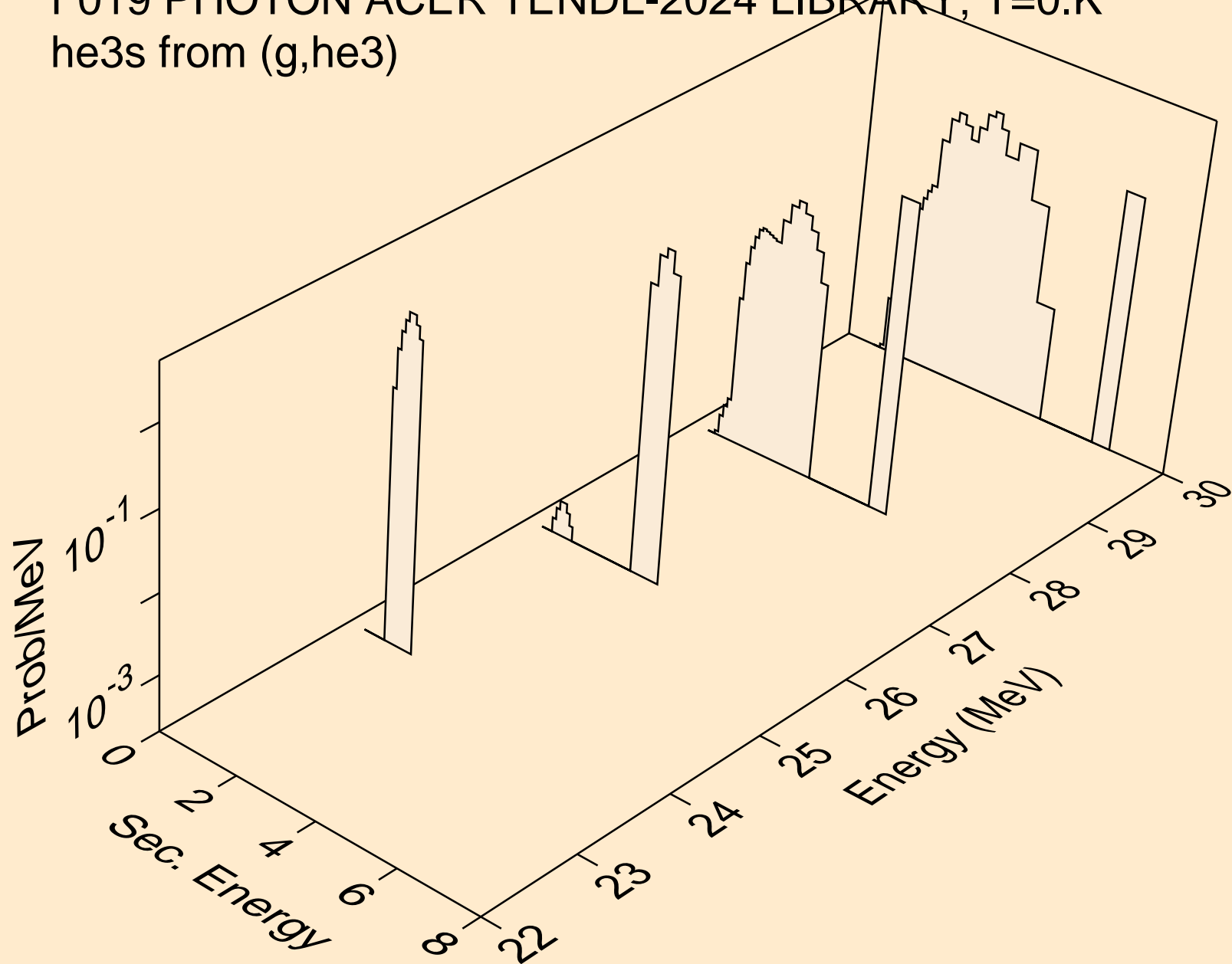

F019 PHOTON ACER TENDL-2024 LIBRARY; T=0.K
alphas from (g,x)

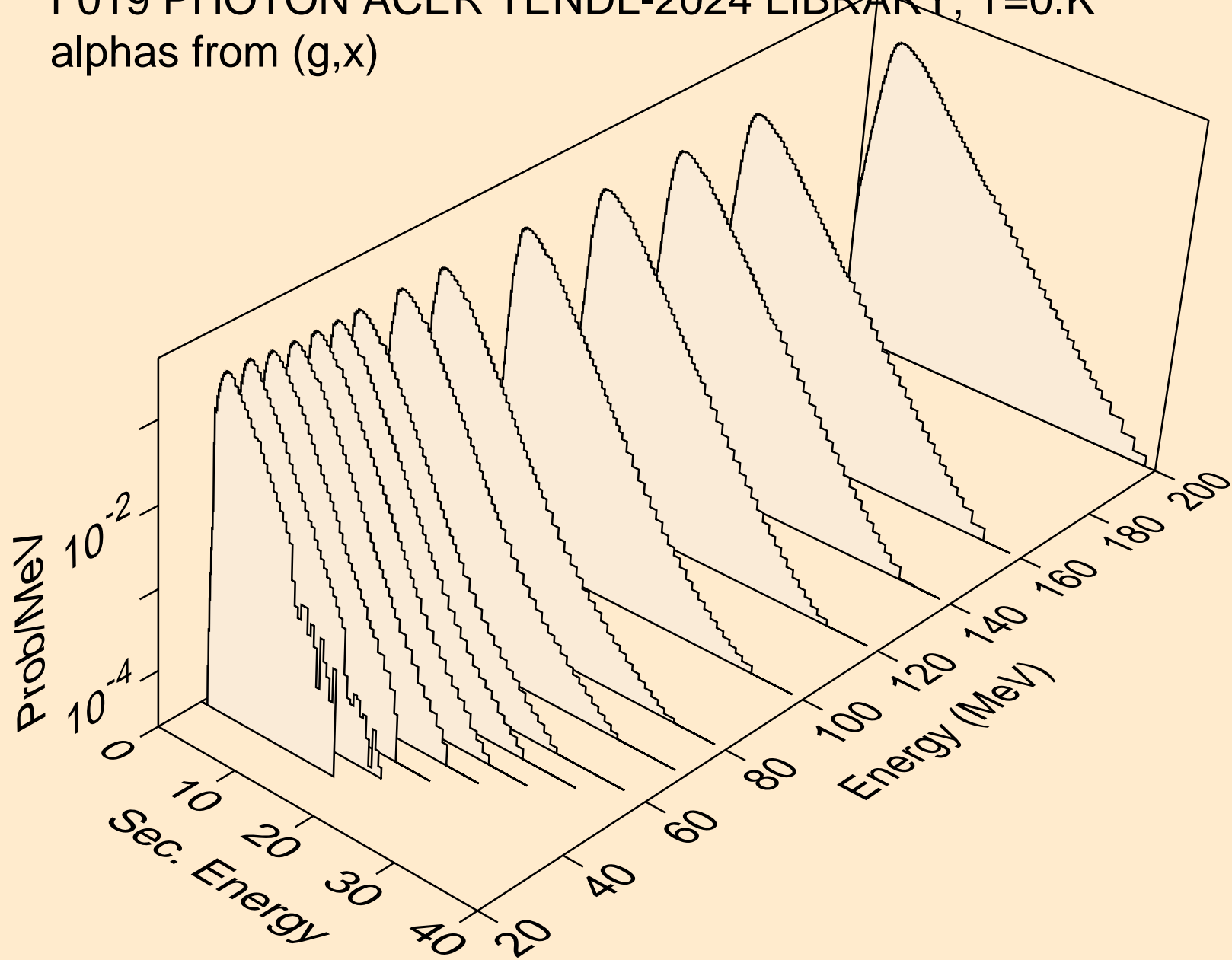

F019 PHOTON ACER TENDL-2024 LIBRARY; T=0.K
alphas from (g,n*)a

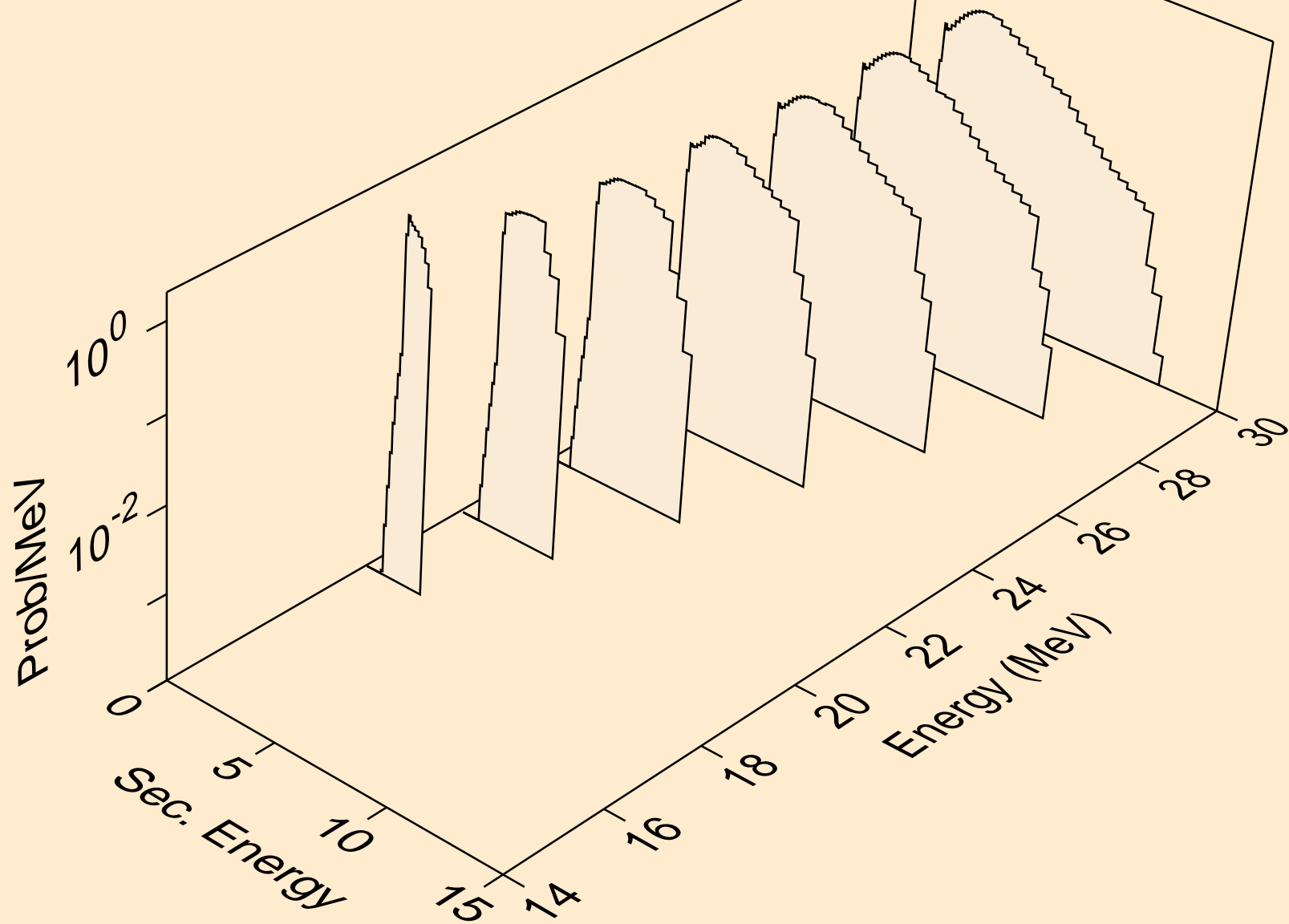

F019 PHOTON ACER TENDL-2024 LIBRARY; T=0.K
alphas from (g,2n)a

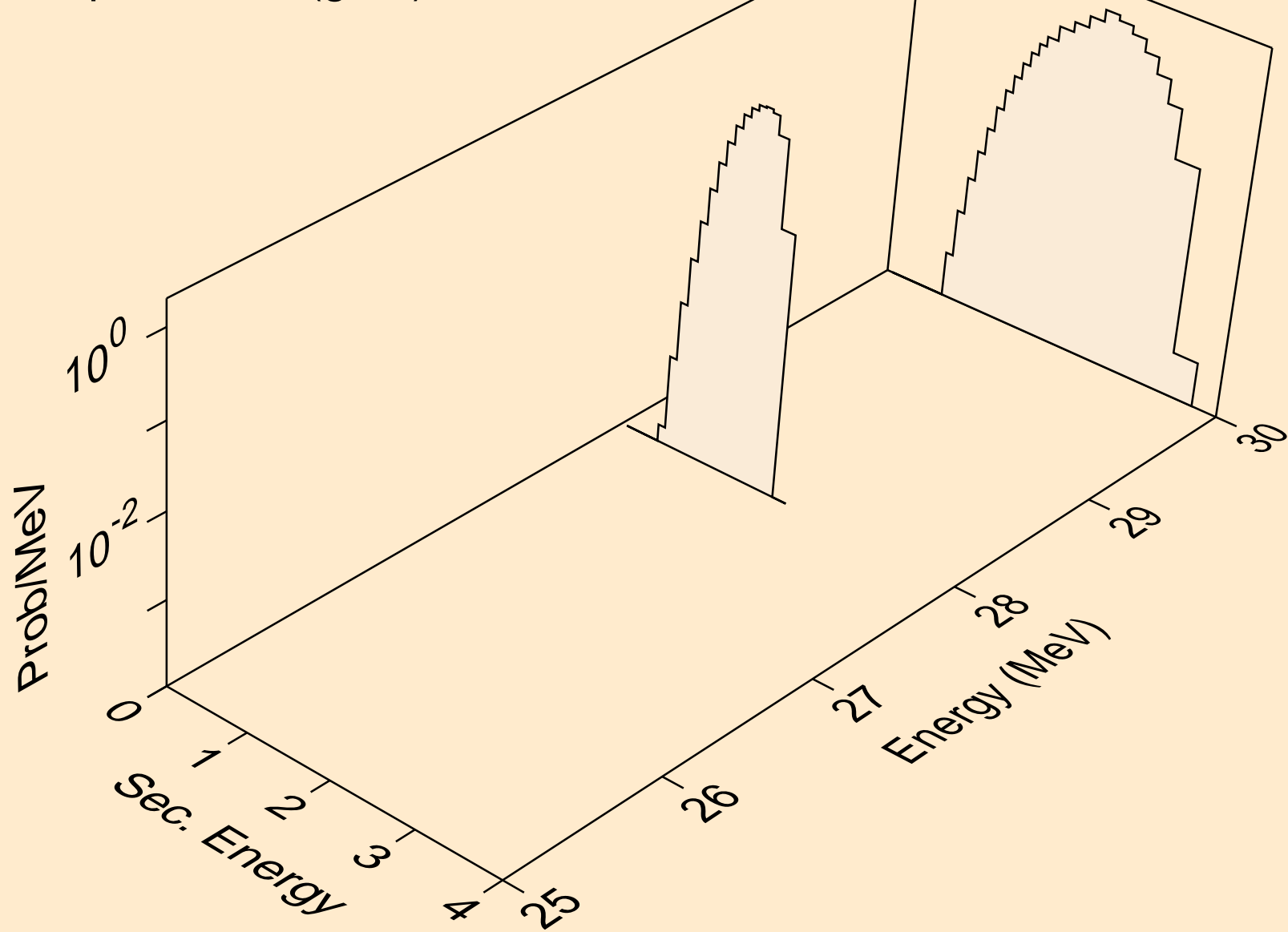

F019 PHOTON ACER TENDL-2024 LIBRARY; T=0.K
alphas from (g,npa)

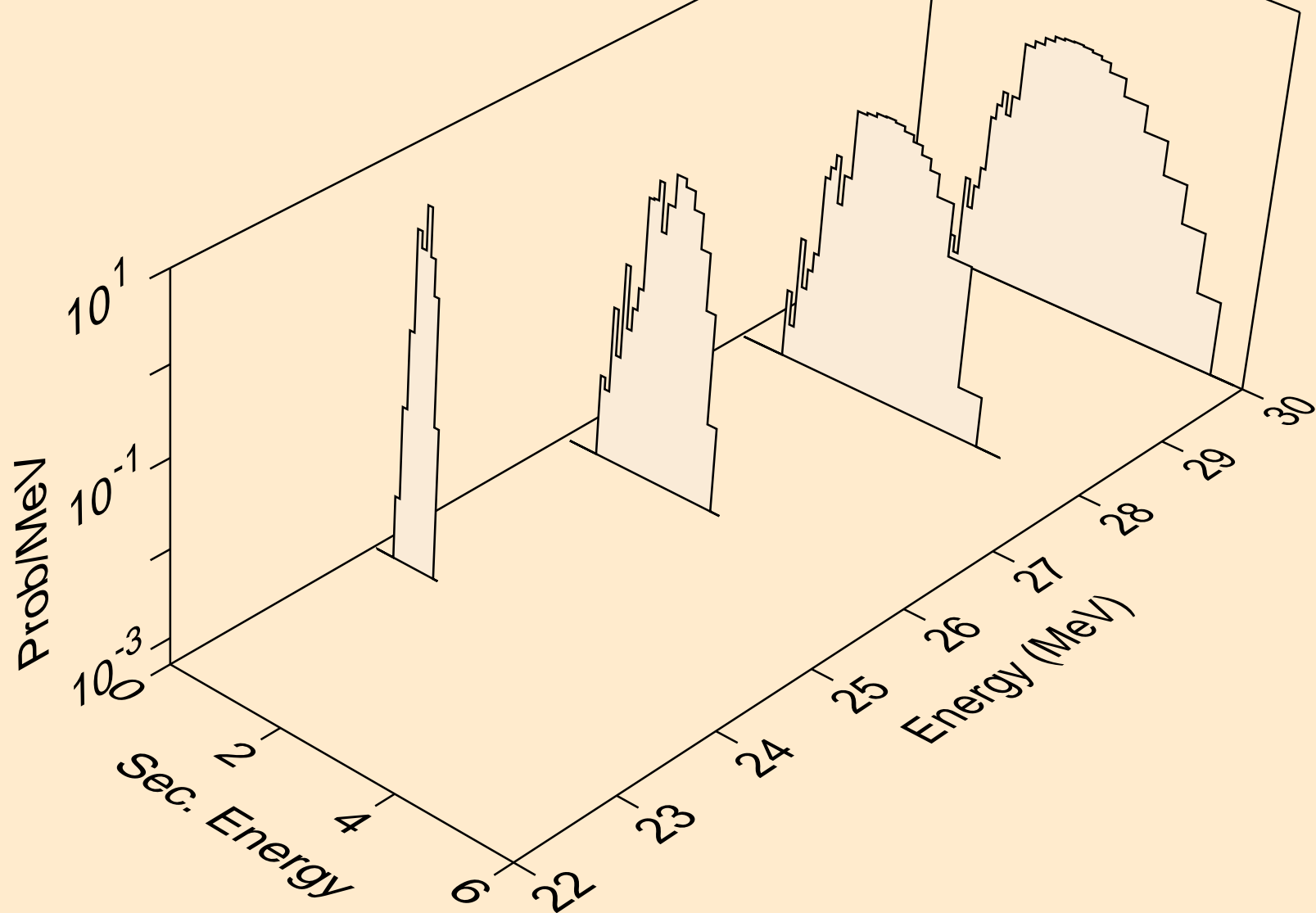

F019 PHOTON ACER TENDL-2024 LIBRARY; T=0.K
alphas from (g,a)

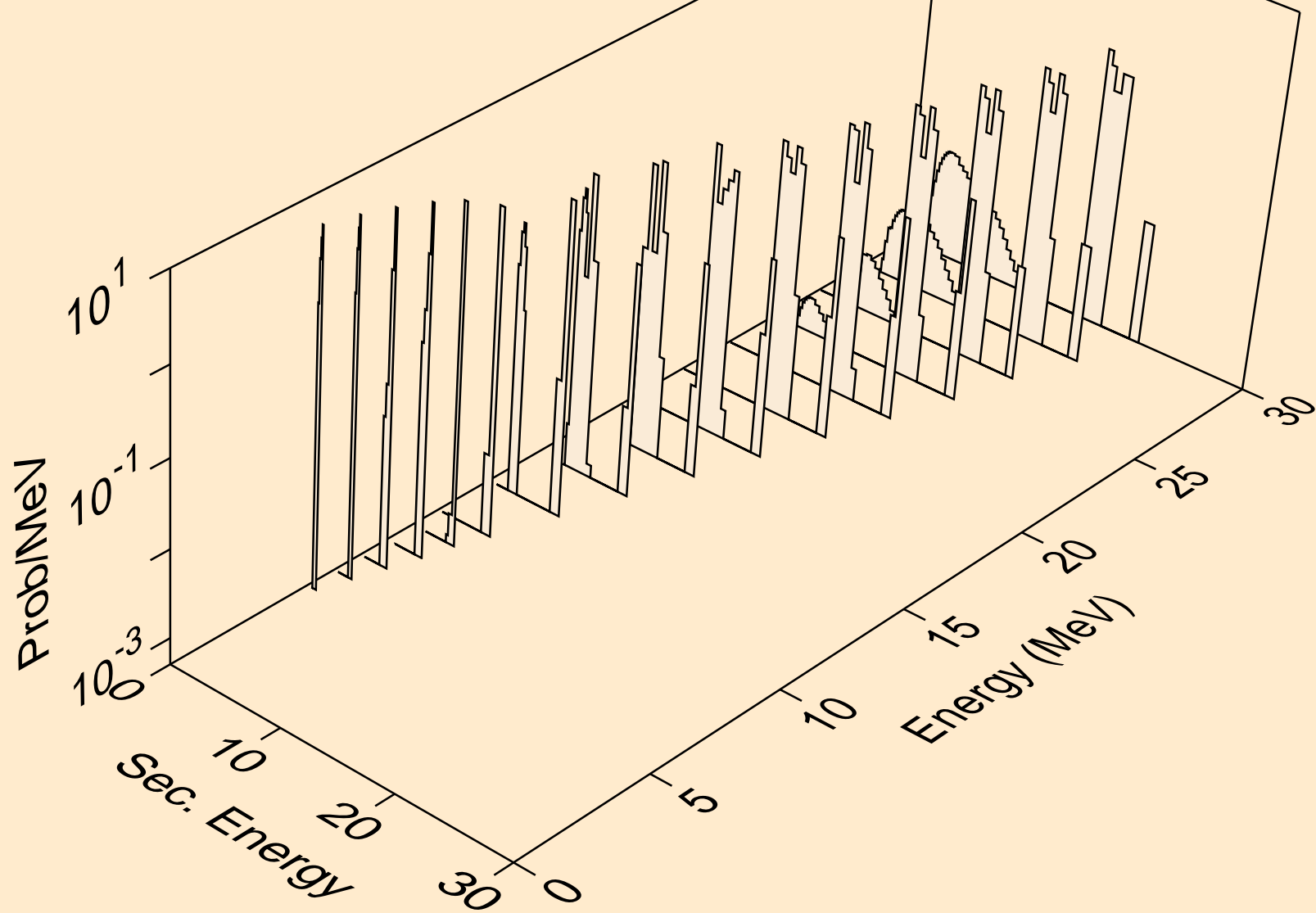

F019 PHOTON ACER TENDL-2024 LIBRARY; T=0.K
alphas from (g,2a)

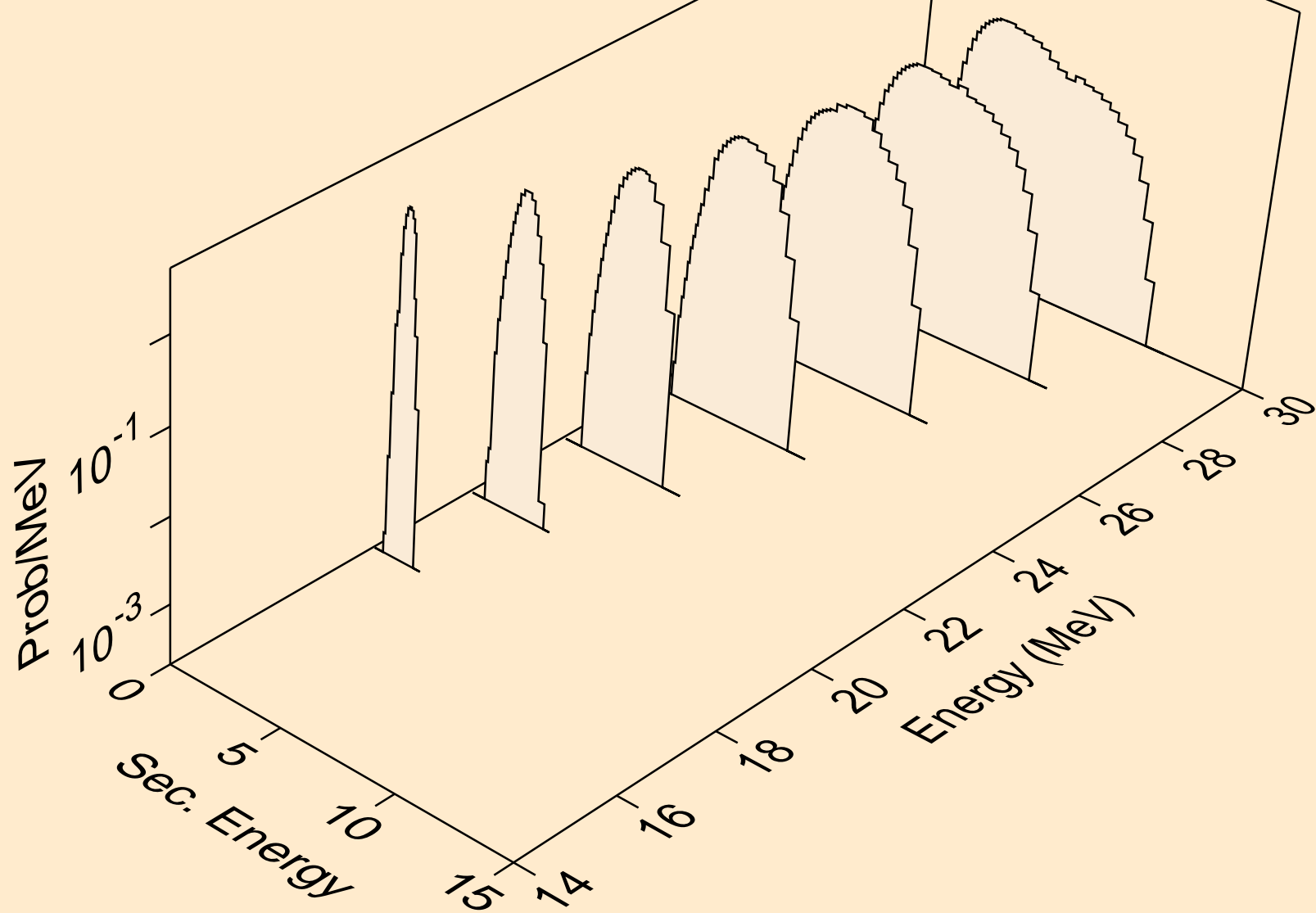

F019 PHOTON ACER TENDL-2024 LIBRARY; T=0.K
alphas from (g,pa)

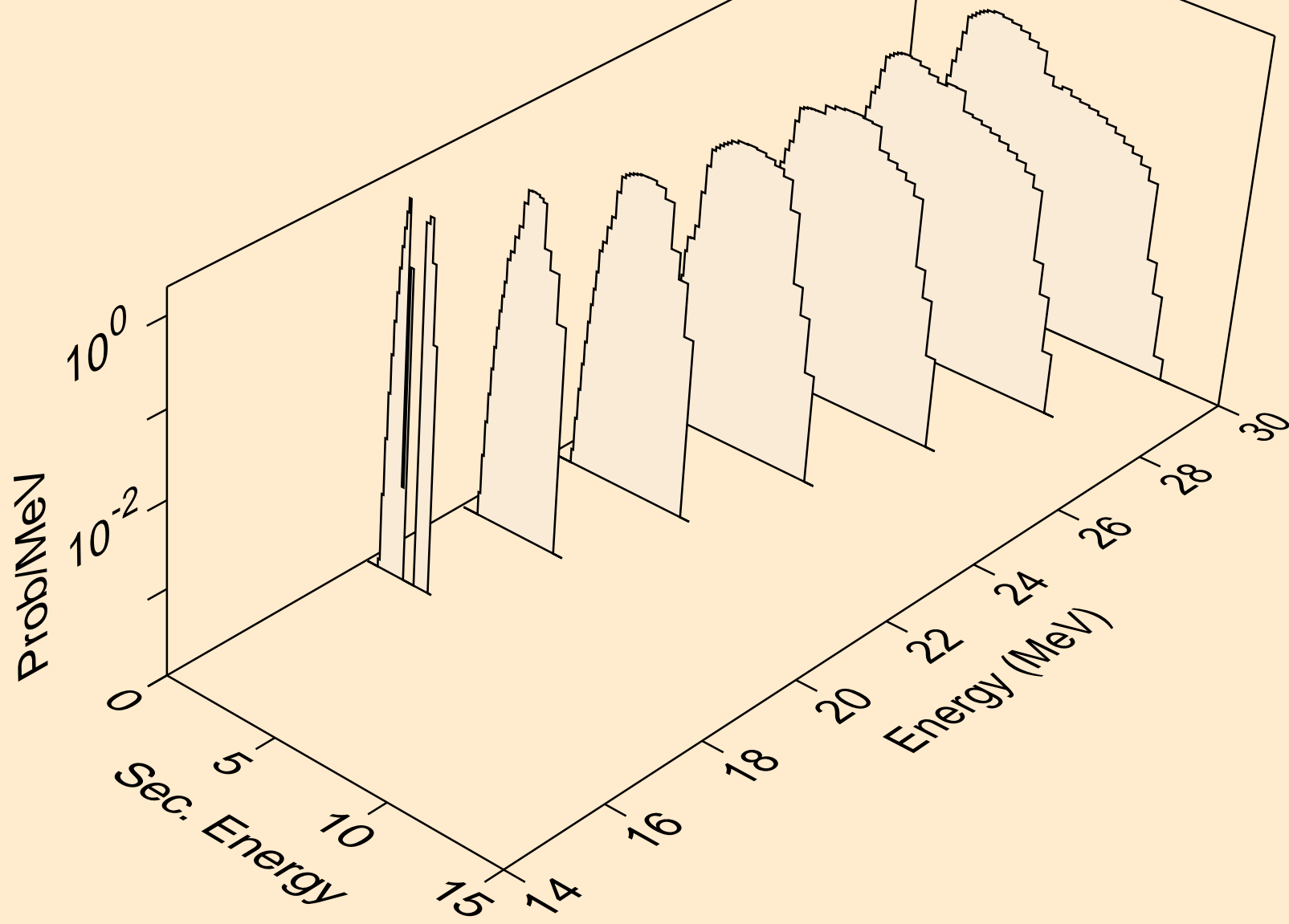

F019 PHOTON ACER TENDL-2024 LIBRARY; T=0.K
alphas from (g,da)

