

P033 PHOTON ACER TENDL-2024 LIBRARY; T=0.K

Principal cross sections

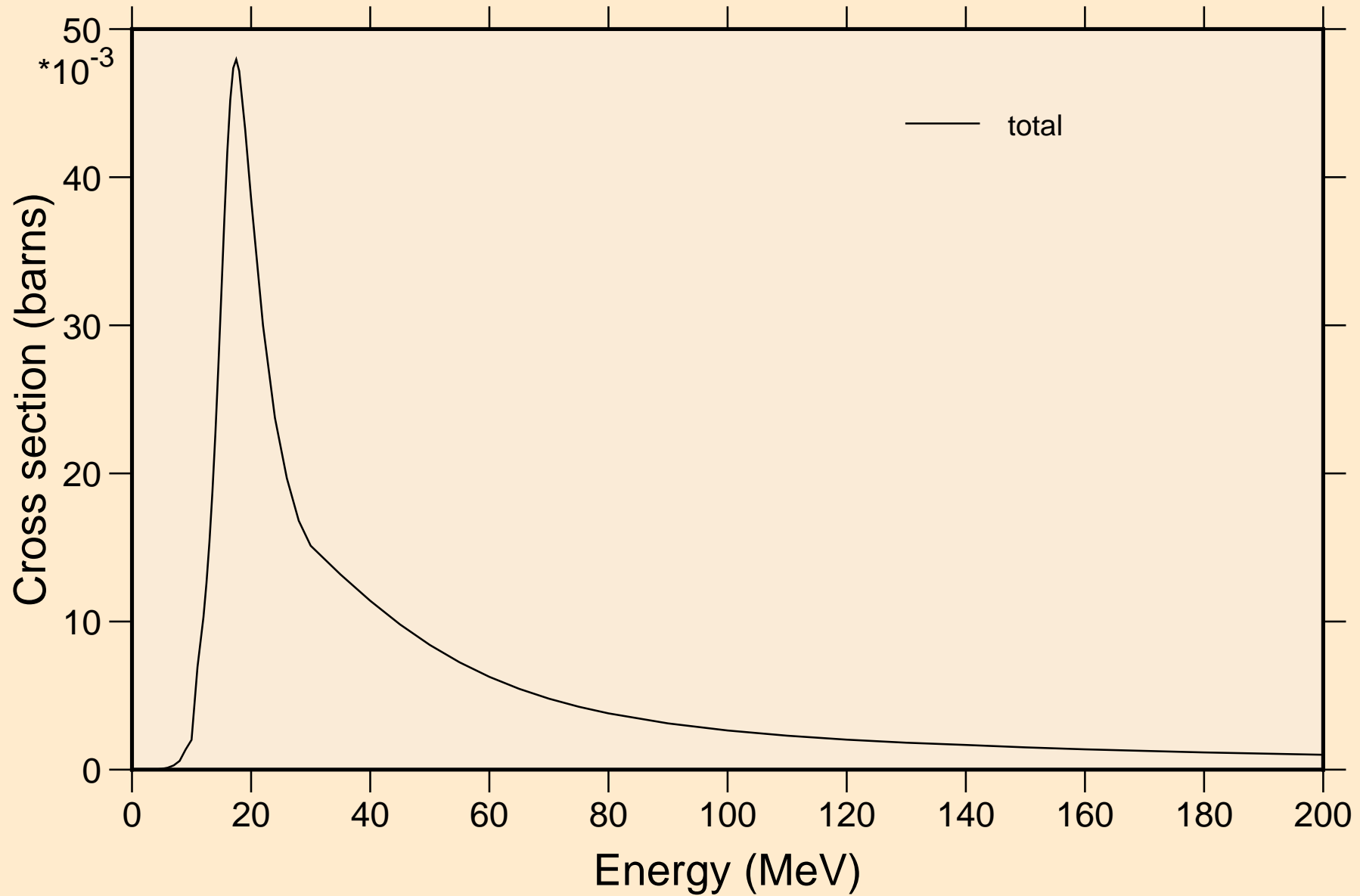

P033 PHOTON ACER TENDL-2024 LIBRARY; T=0.K
Partial cross sections

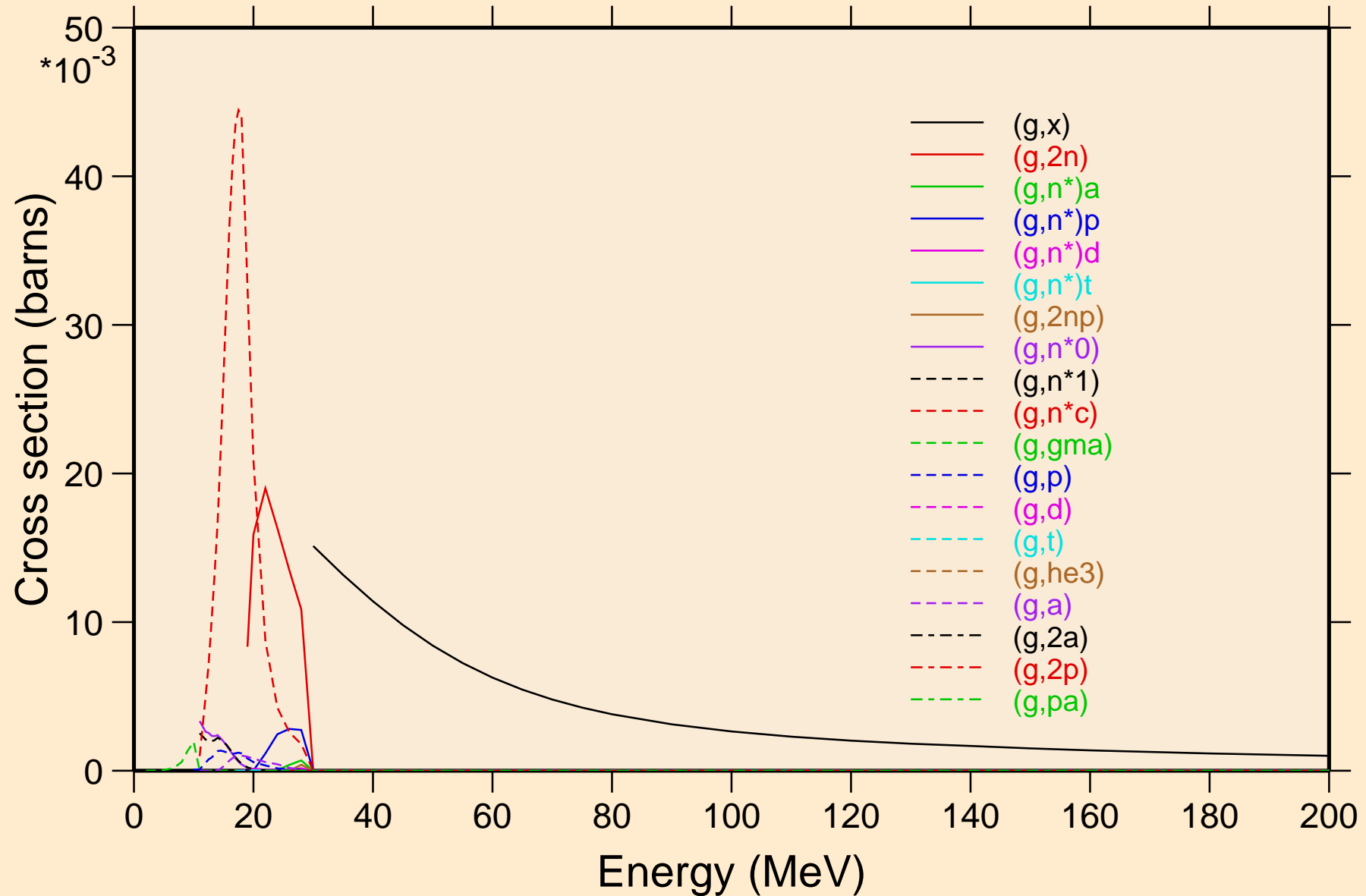

P033 PHOTON ACER TENDL-2024 LIBRARY; T=0.K

Heating

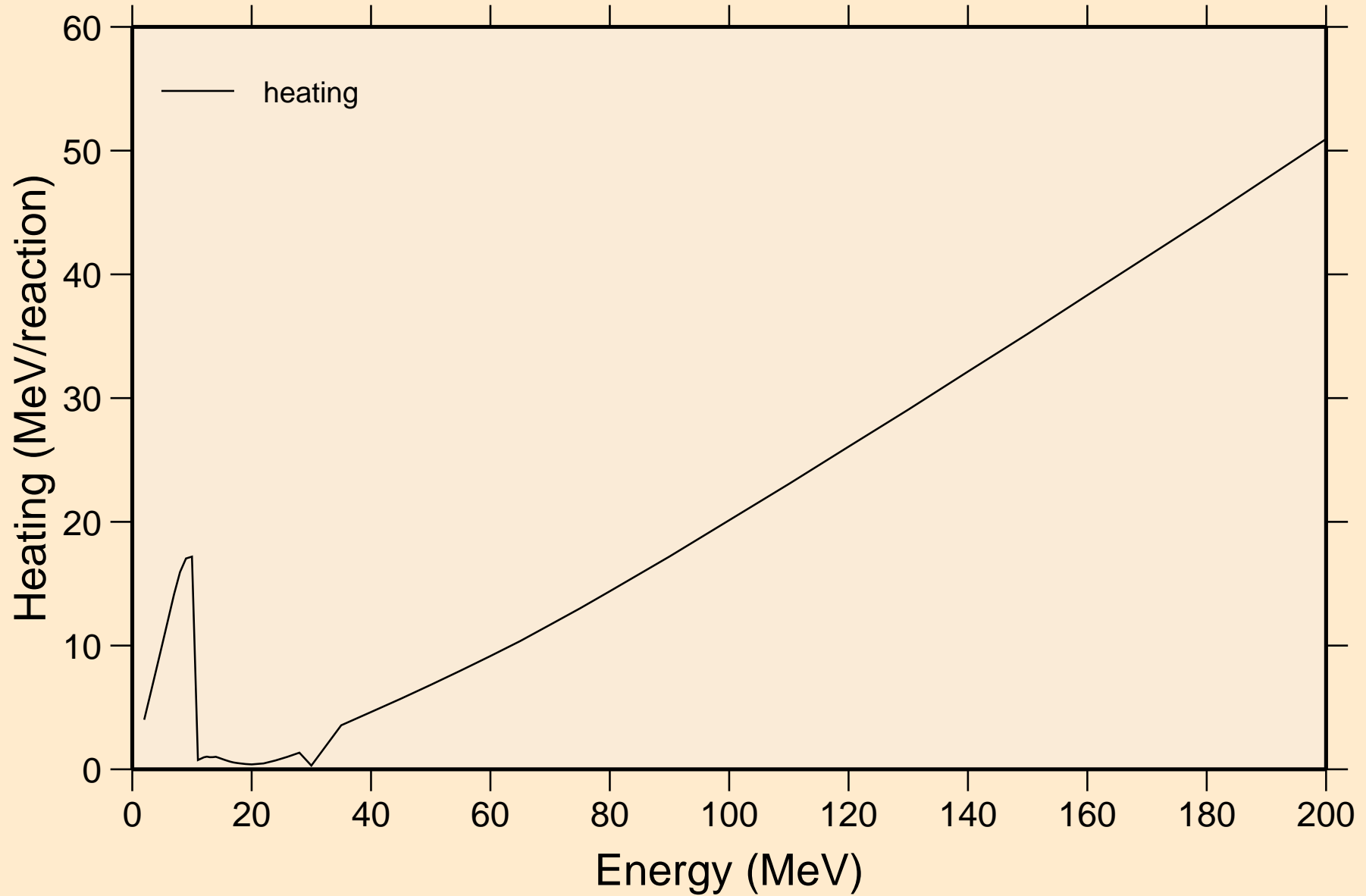

P033 PHOTON ACER TENDL-2024 LIBRARY; T=0.K

Particle heating contributions

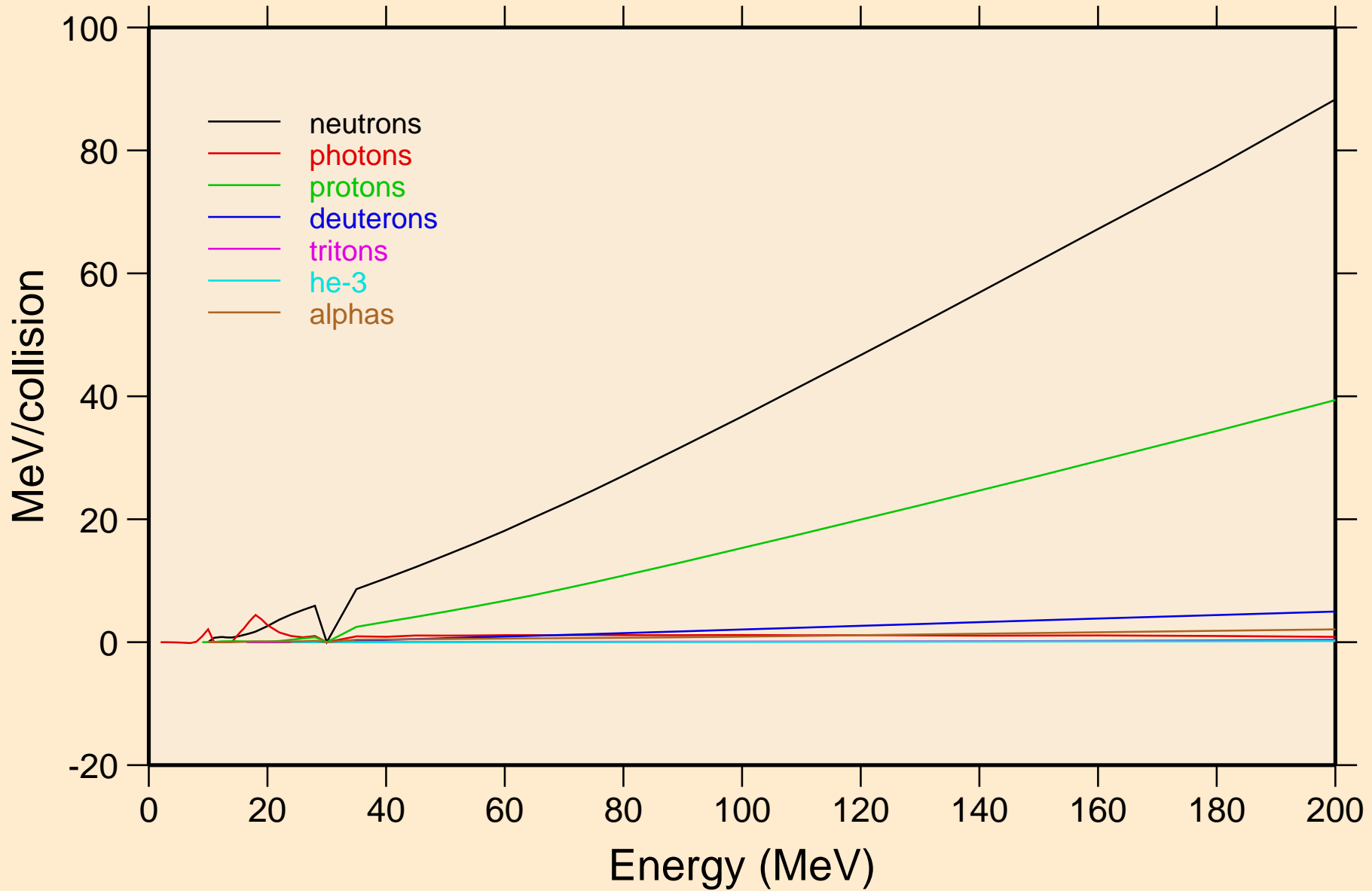

P033 PHOTON ACER TENDL-2024 LIBRARY; T=0.K
Particle production cross sections

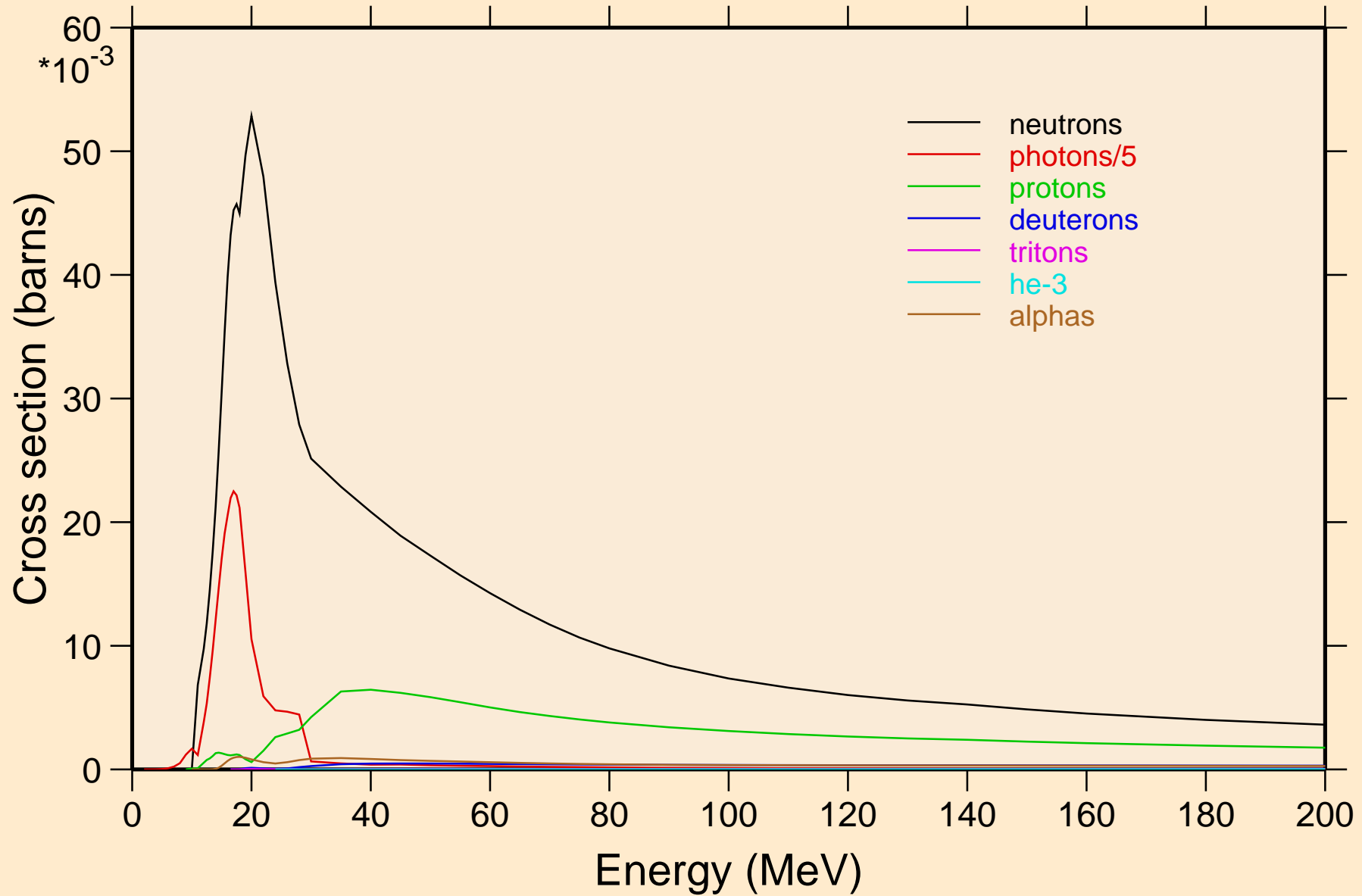

P033 PHOTON ACER TENDL-2024 LIBRARY; T=0.K
neutrons from (g,x)

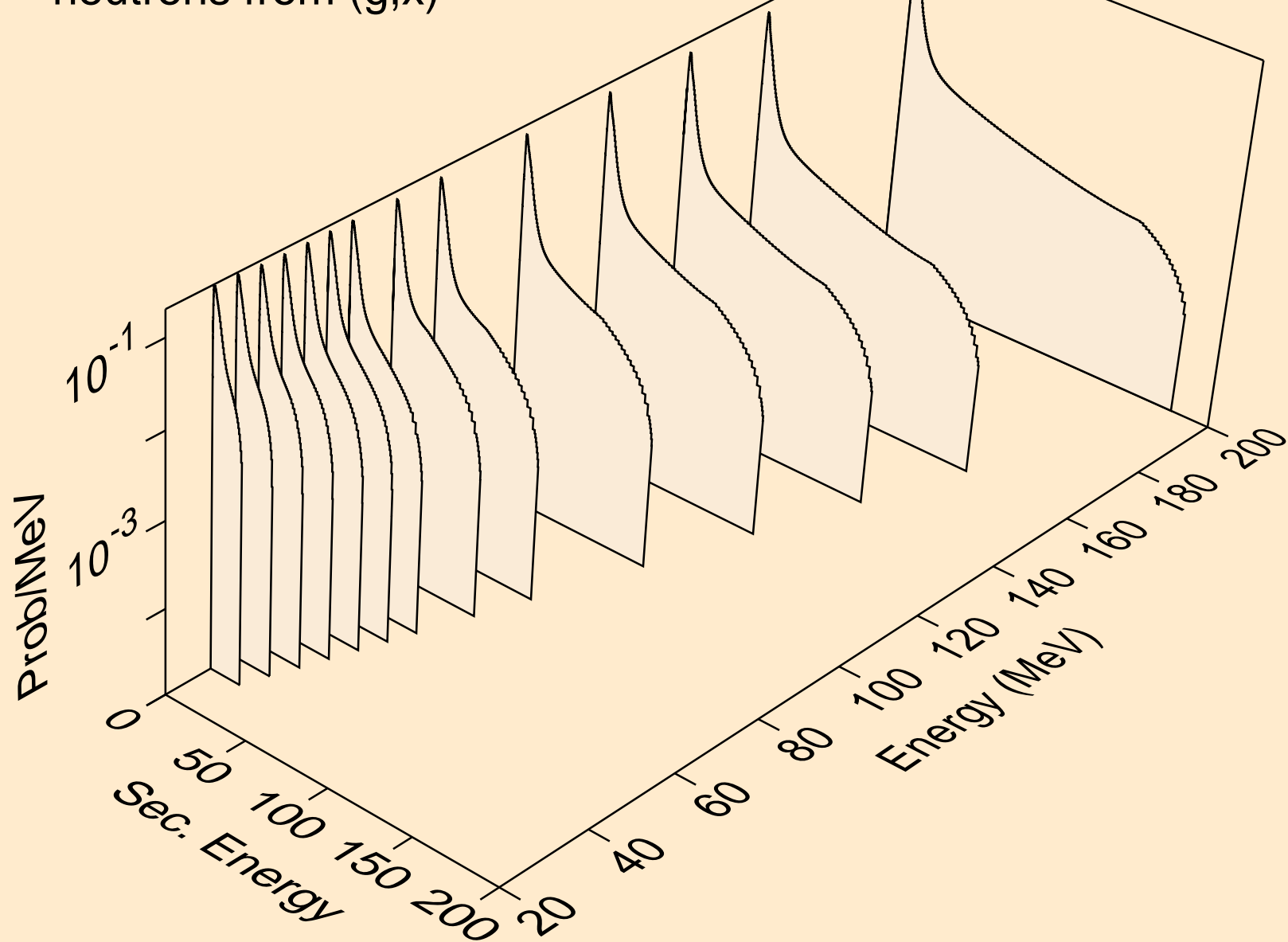

P033 PHOTON ACER TENDL-2024 LIBRARY; T=0.K
neutrons from (g,2n)

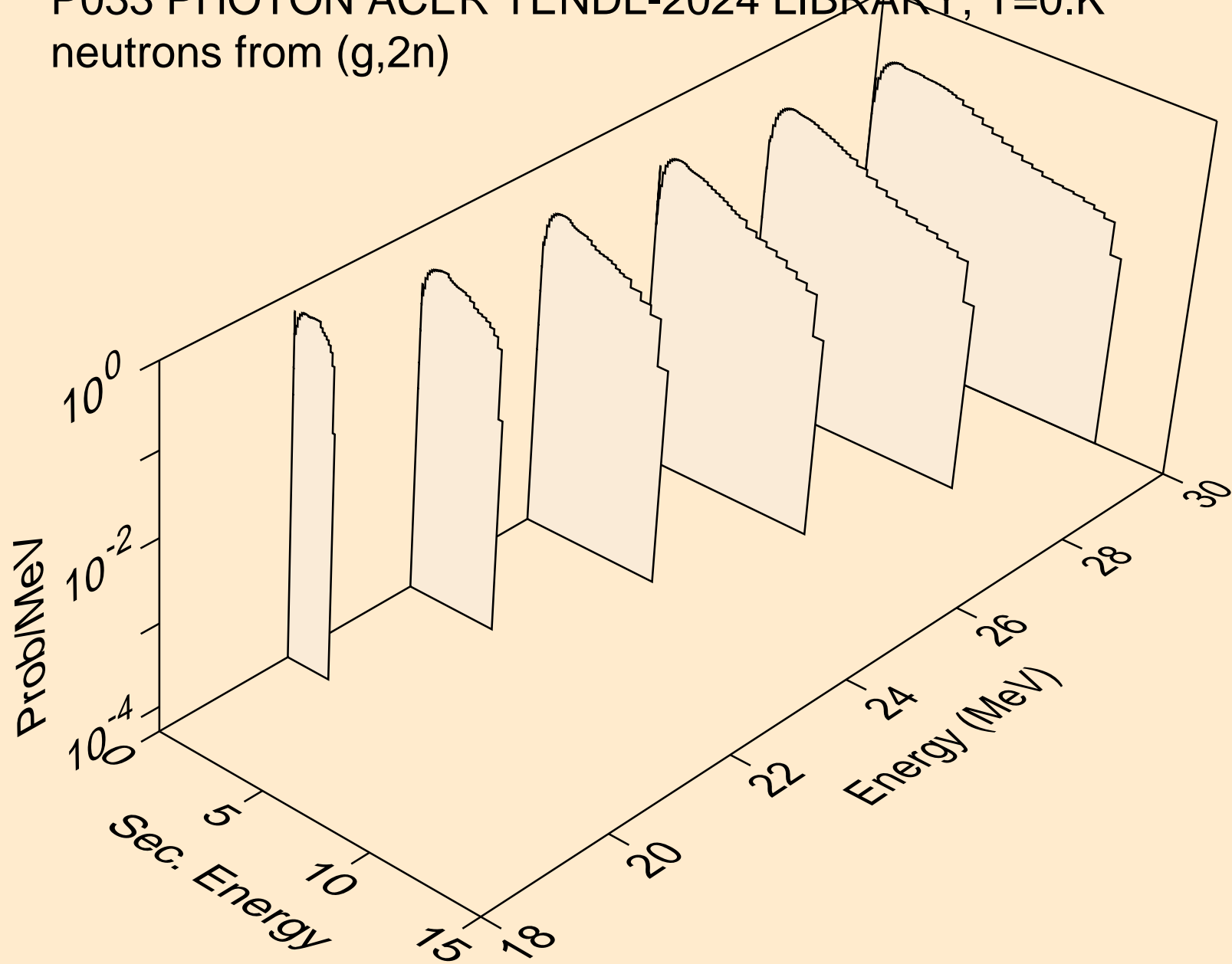

P033 PHOTON ACER TENDL-2024 LIBRARY; T=0.K
neutrons from (g,n*)a

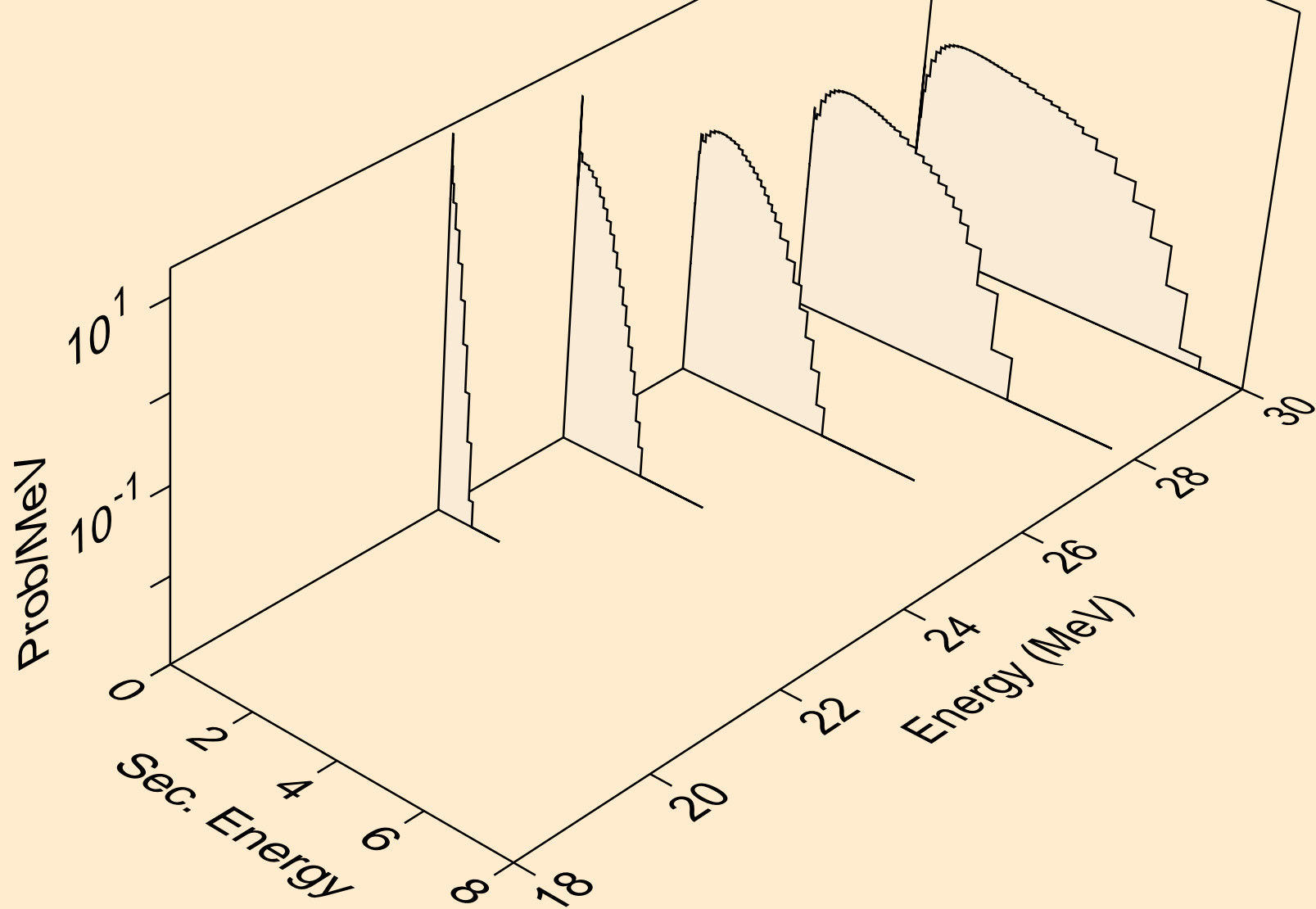

P033 PHOTON ACER TENDL-2024 LIBRARY; T=0.K
neutrons from (g,n*)p

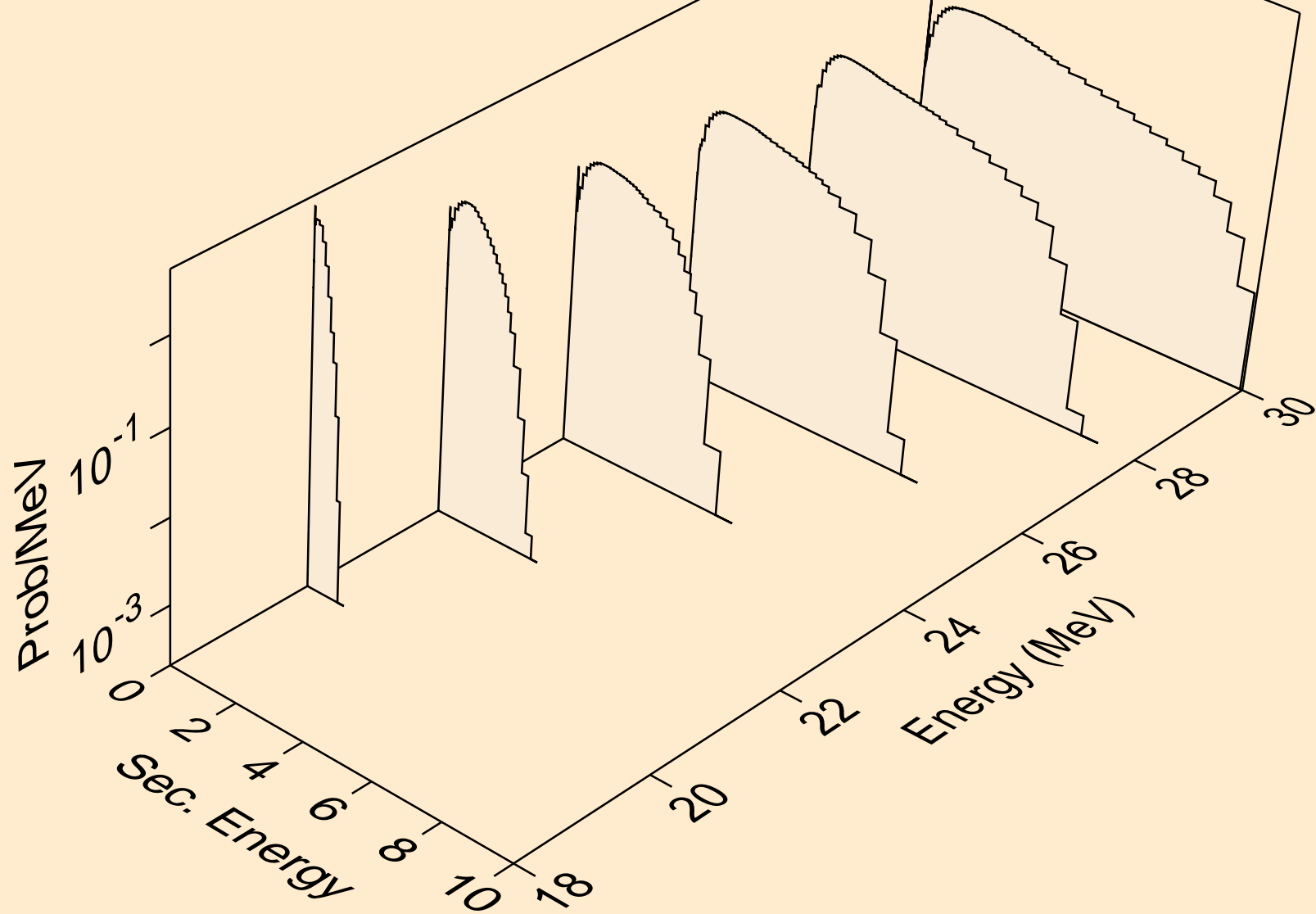

P033 PHOTON ACER TENDL-2024 LIBRARY; T=0.K
neutrons from (g,n*)d

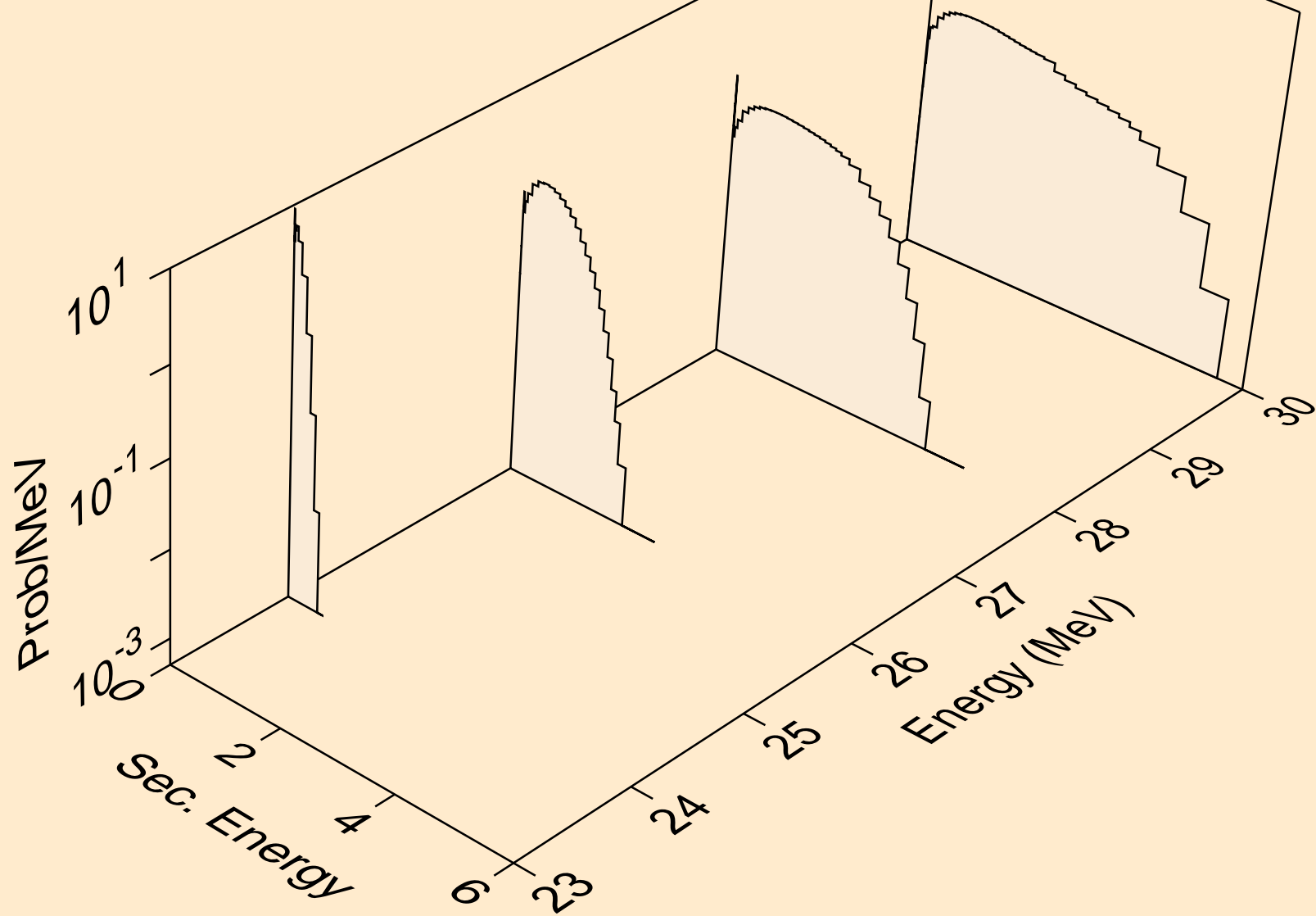

P033 PHOTON ACER TENDL-2024 LIBRARY; T=0.K
neutrons from (g,n*)t

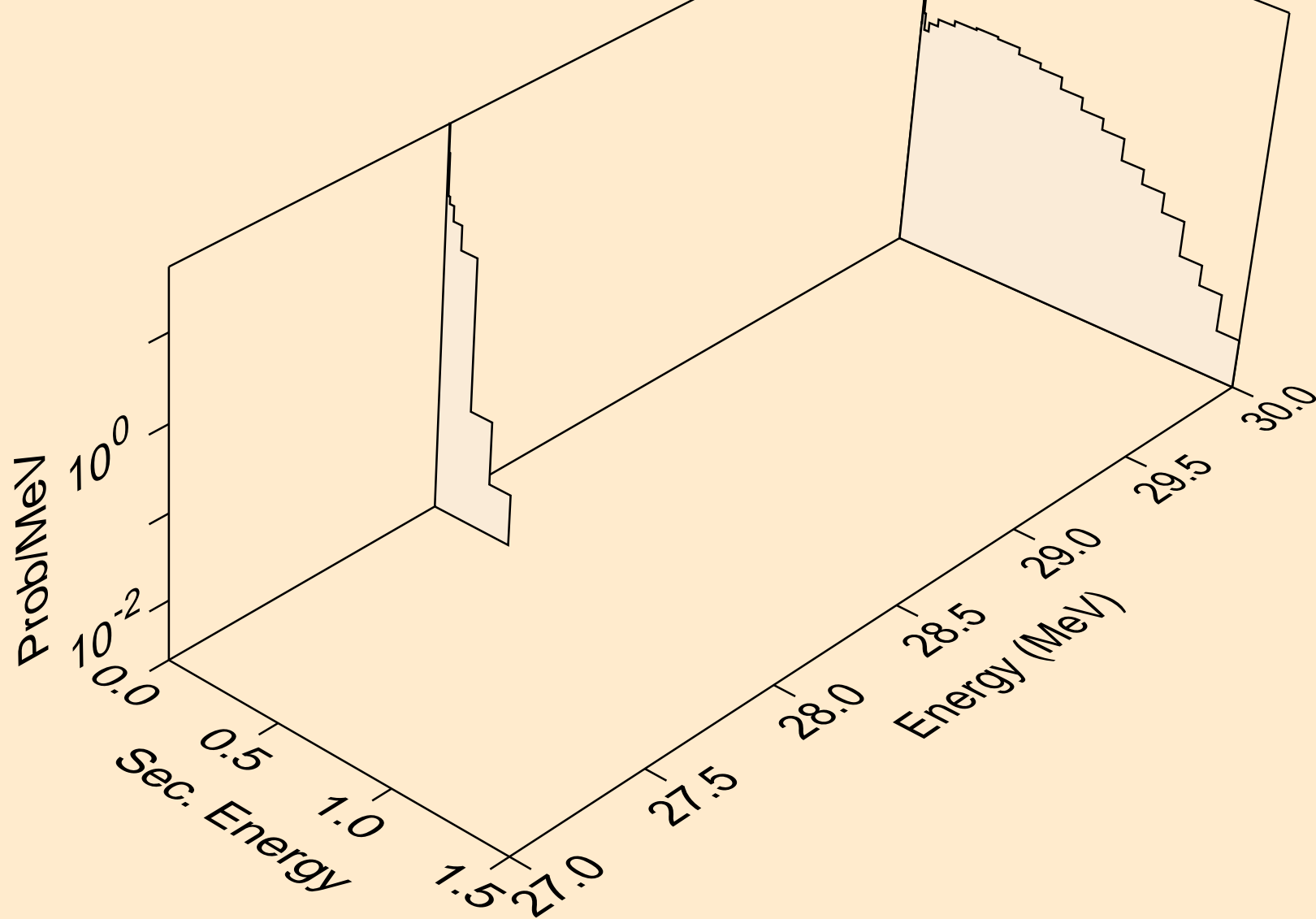

P033 PHOTON ACER TENDL-2024 LIBRARY; T=0.K
neutrons from (g,2np)

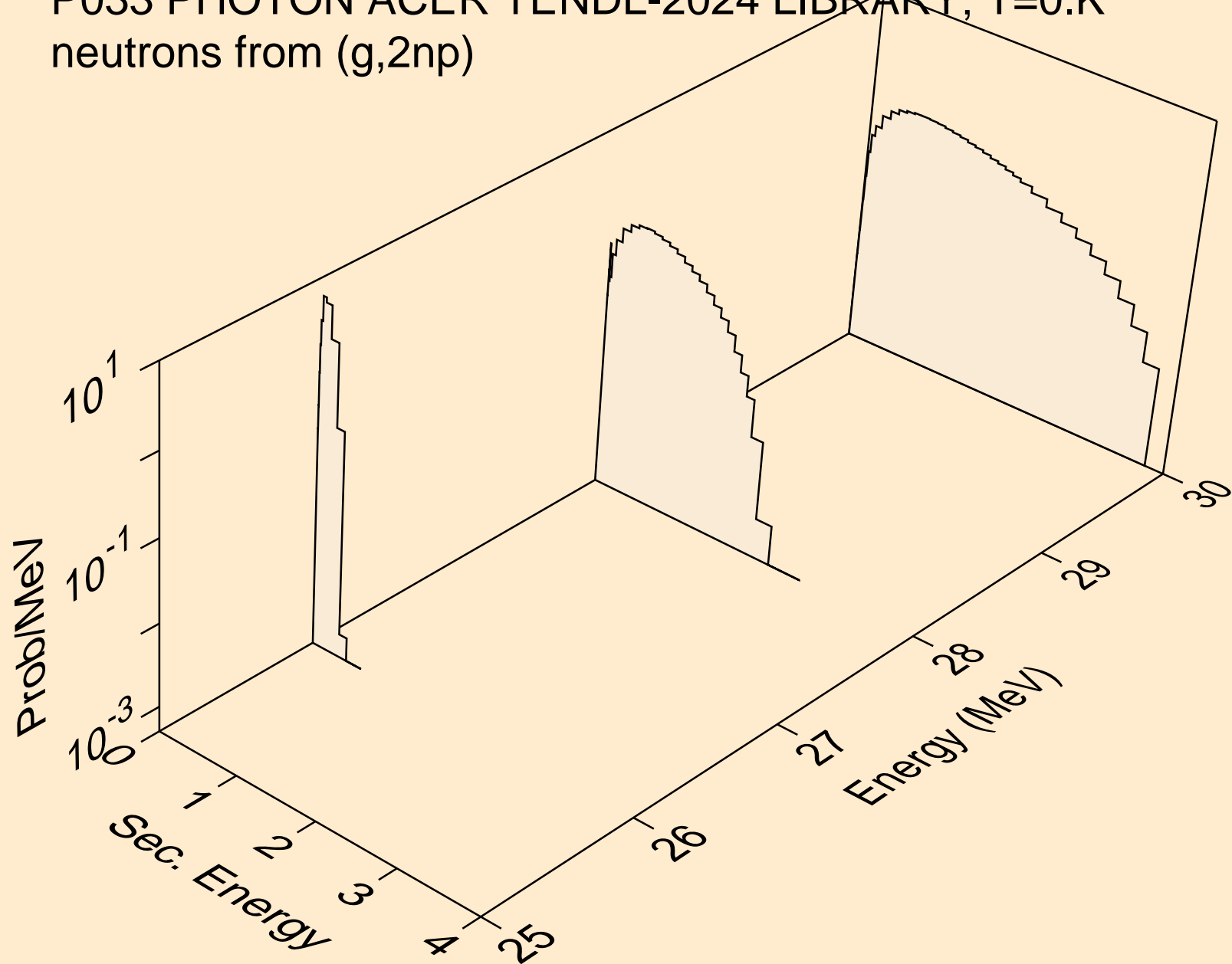

P033 PHOTON ACER TENDL-2024 LIBRARY; T=0.K
angular distribution for (g,n*0) neutron

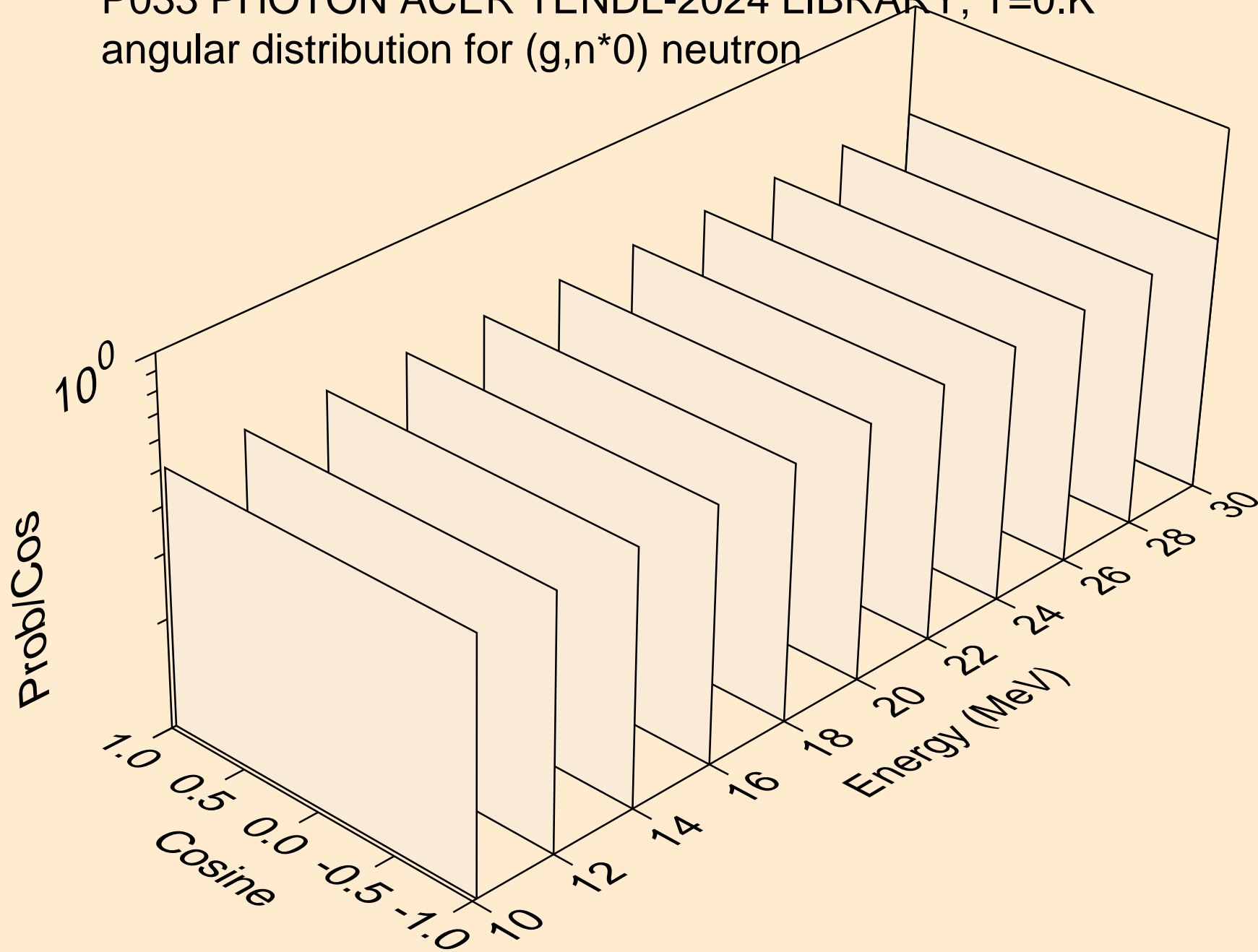

P033 PHOTON ACER TENDL-2024 LIBRARY; T=0.K
angular distribution for (g,n*1) neutron

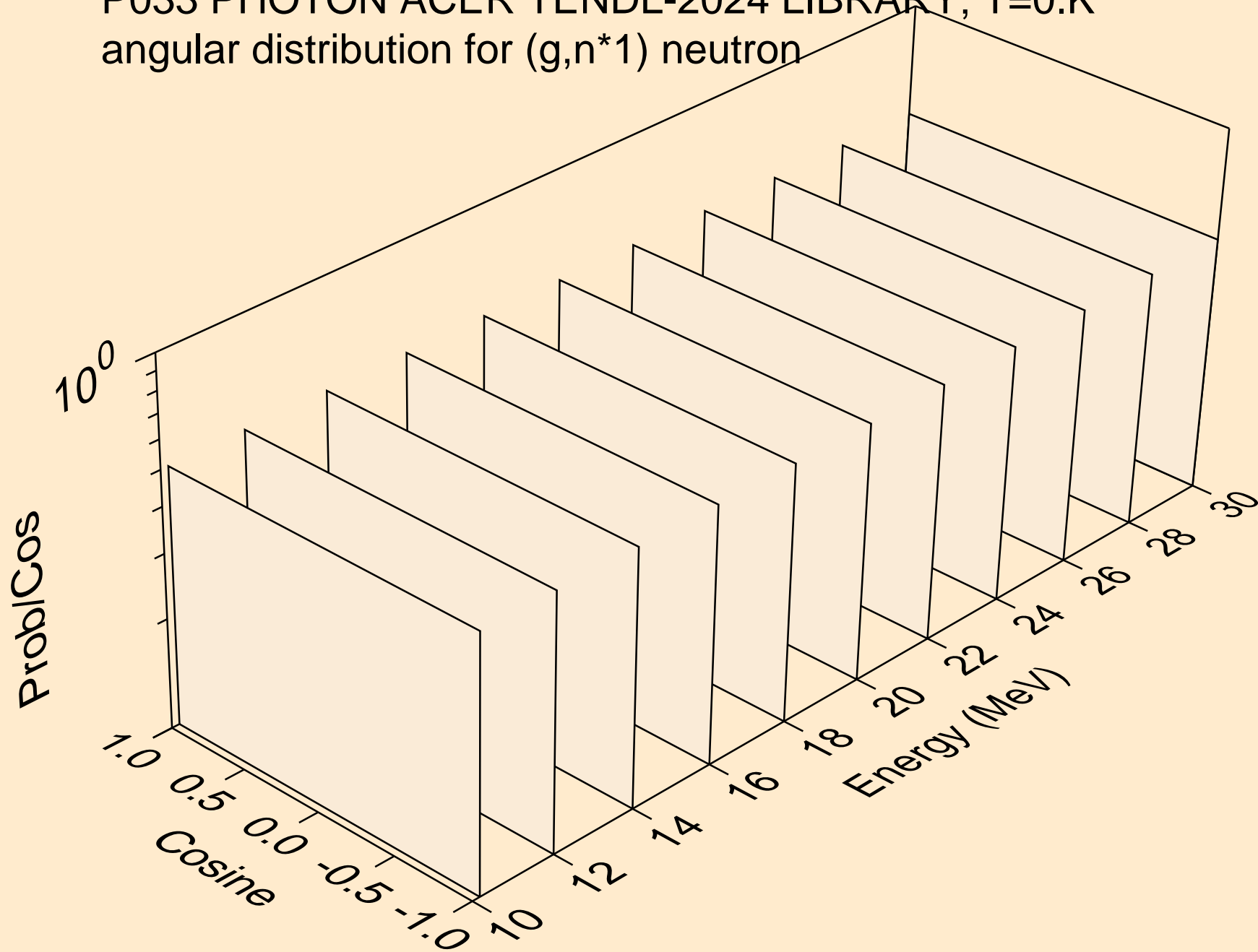

P033 PHOTON ACER TENDL-2024 LIBRARY; T=0.K
neutrons from (g,n*c)

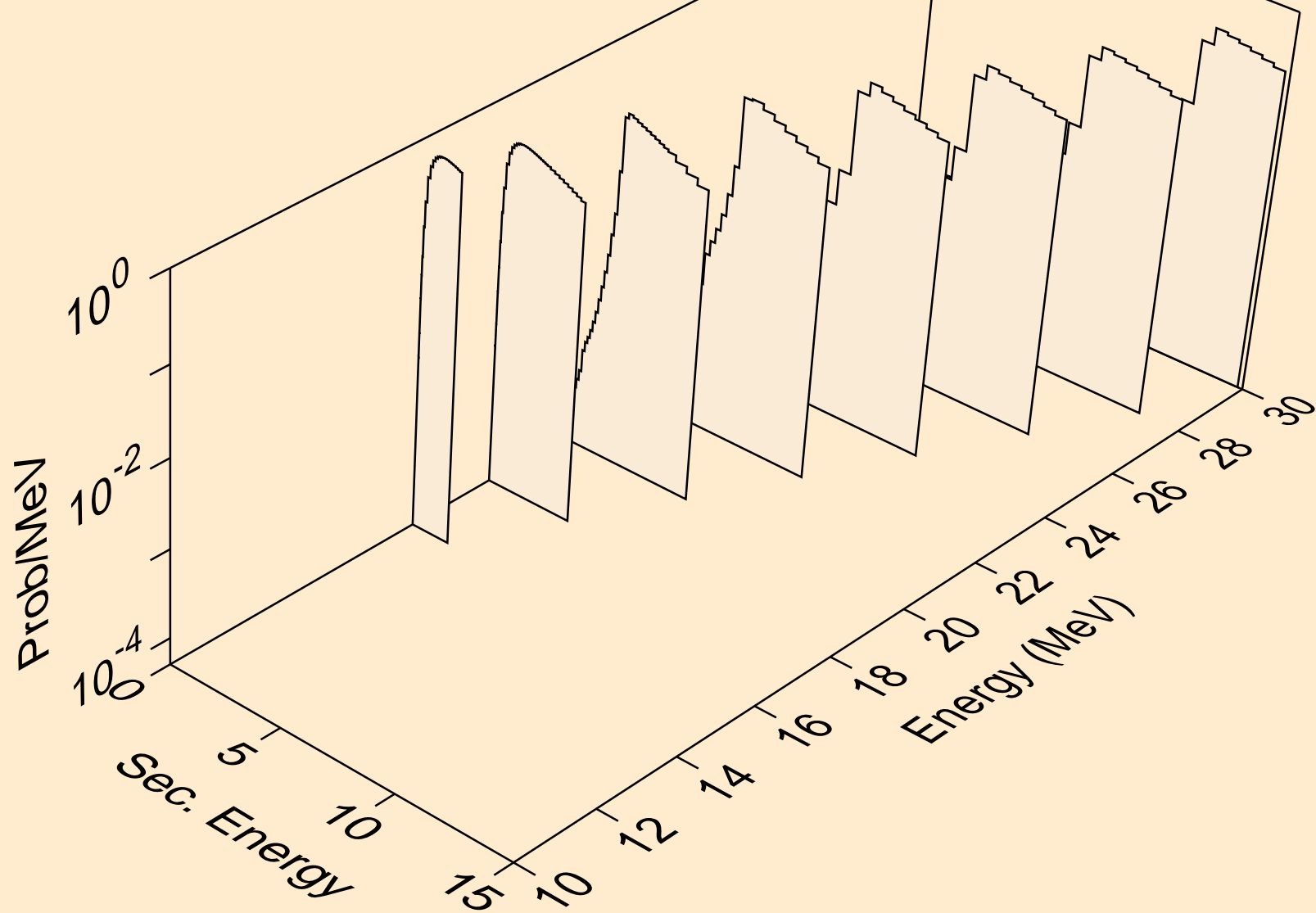

P033 PHOTON ACER TENDL-2024 LIBRARY; T=0.K
photons from (g,x)

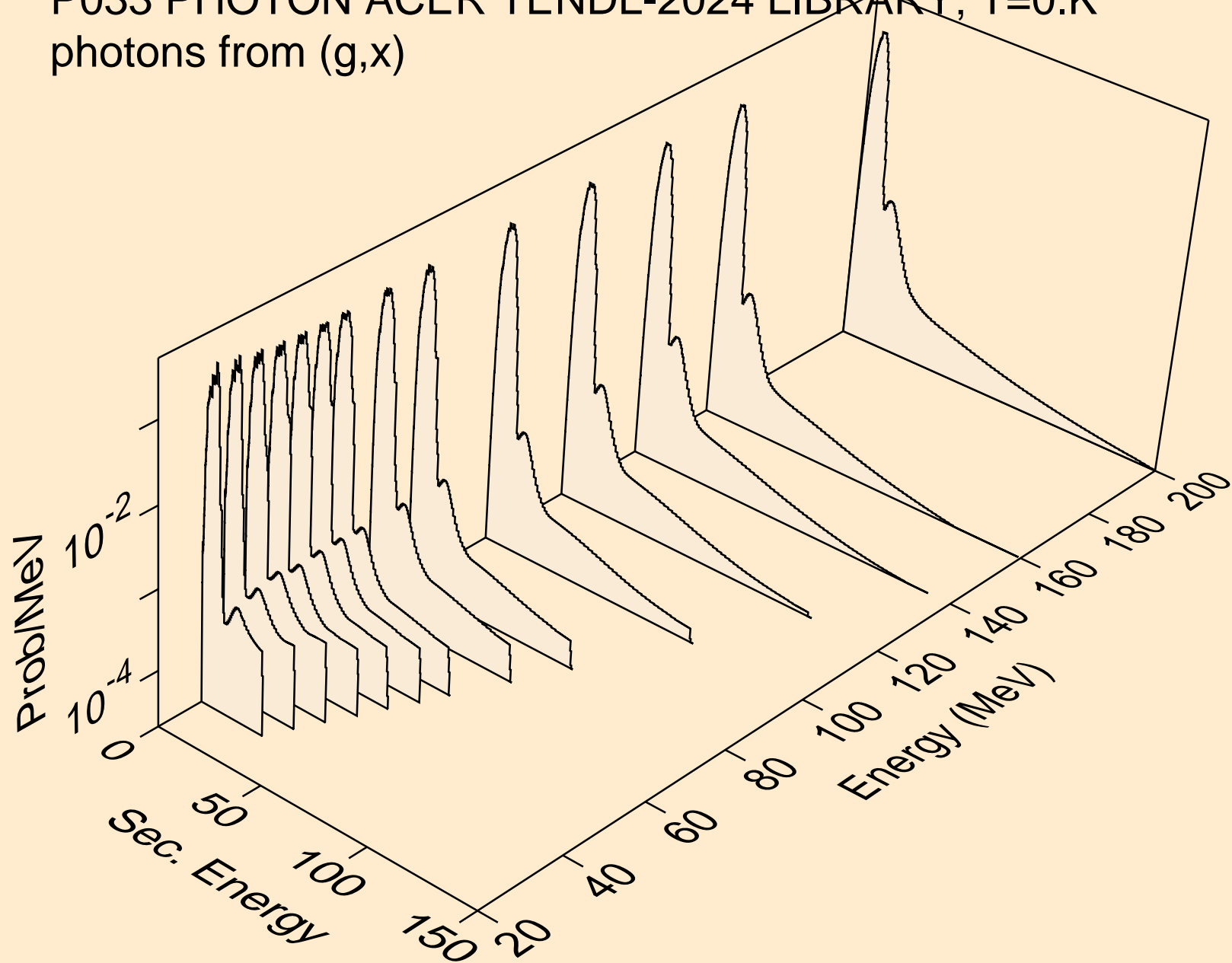

P033 PHOTON ACER TENDL-2024 LIBRARY; T=0.K
photons from (g,2n)

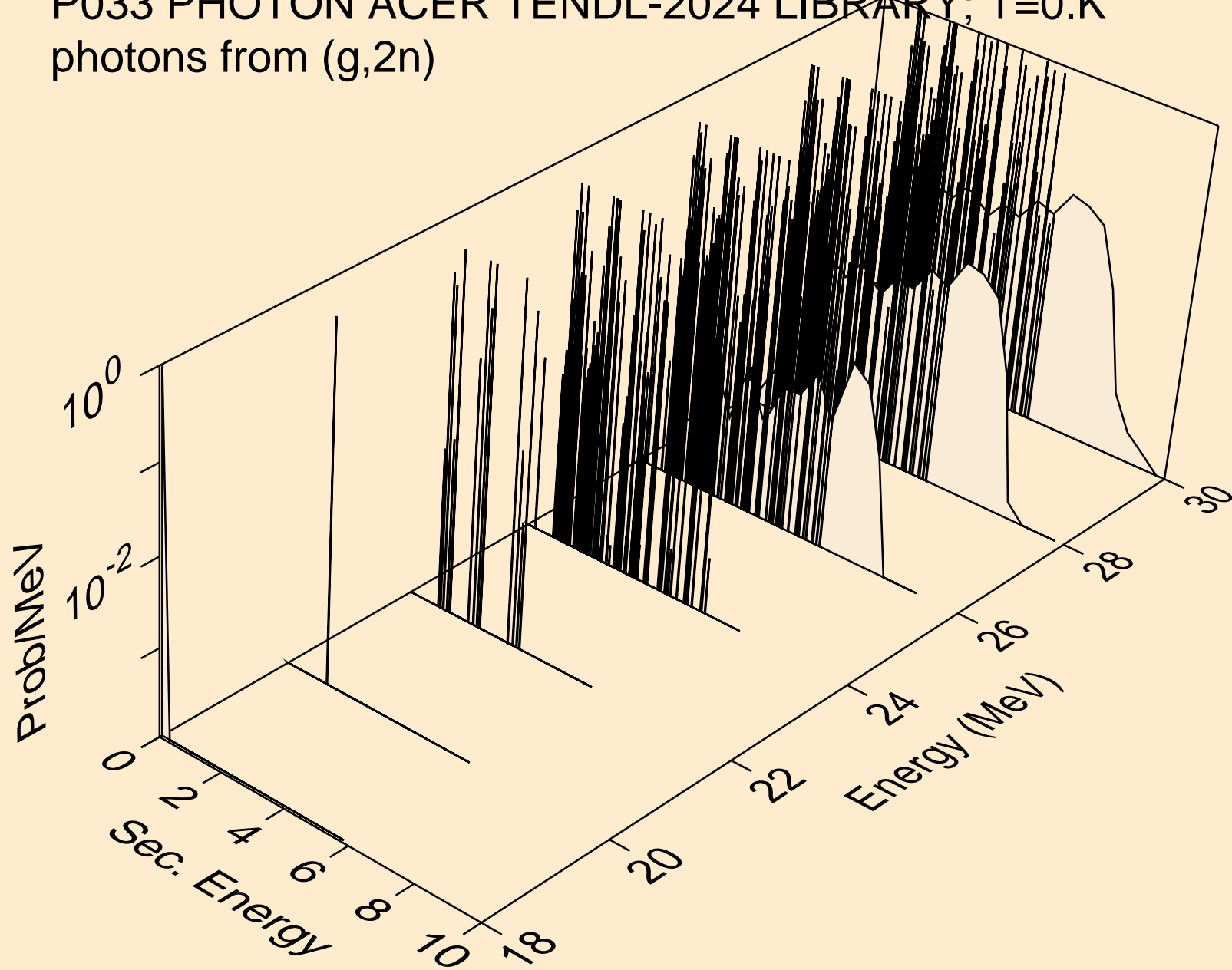

P033 PHOTON ACER TENDL-2024 LIBRARY; T=0.K
photons from (g,n*)a

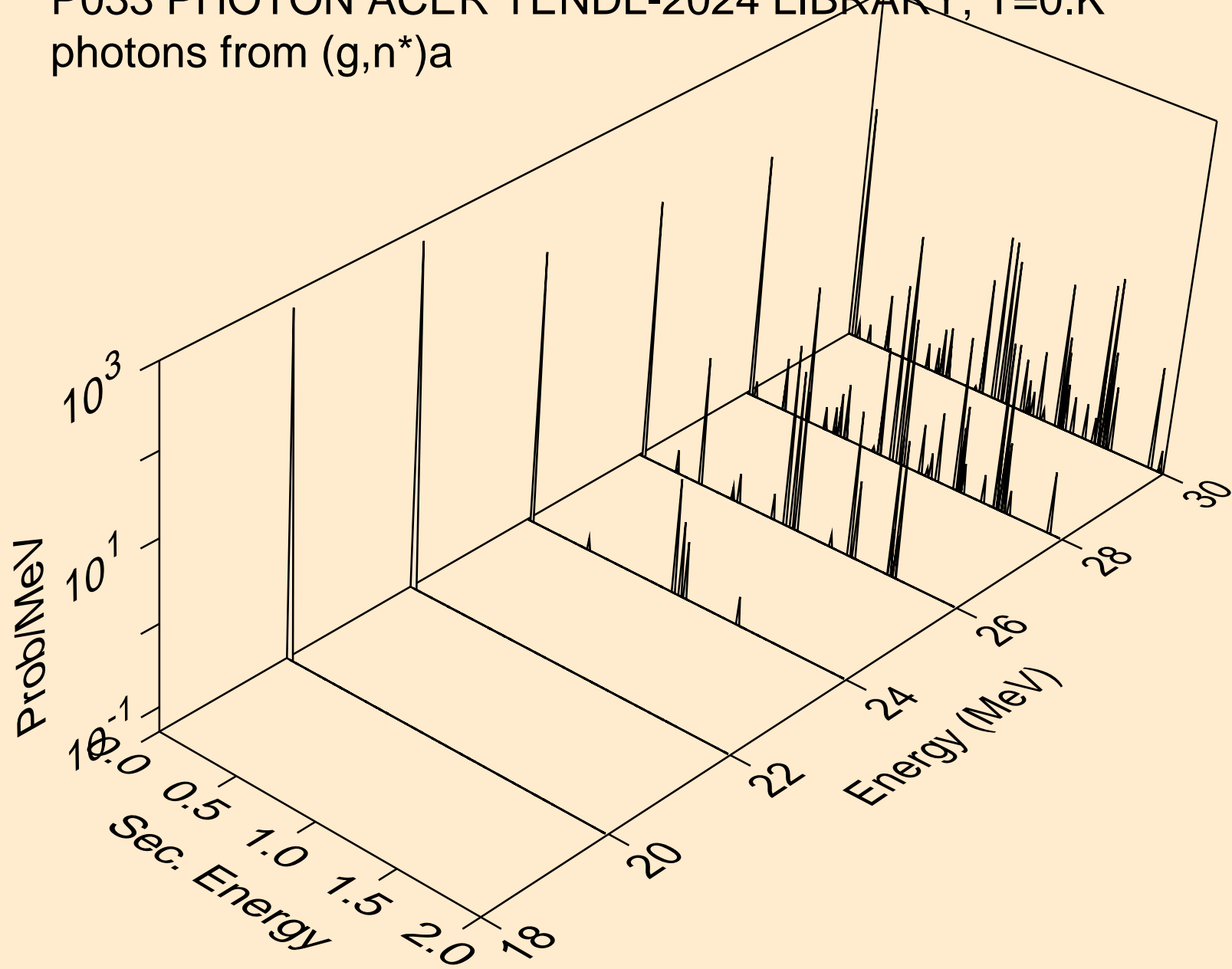

P033 PHOTON ACER TENDL-2024 LIBRARY; T=0.K
photons from (g,n*)p

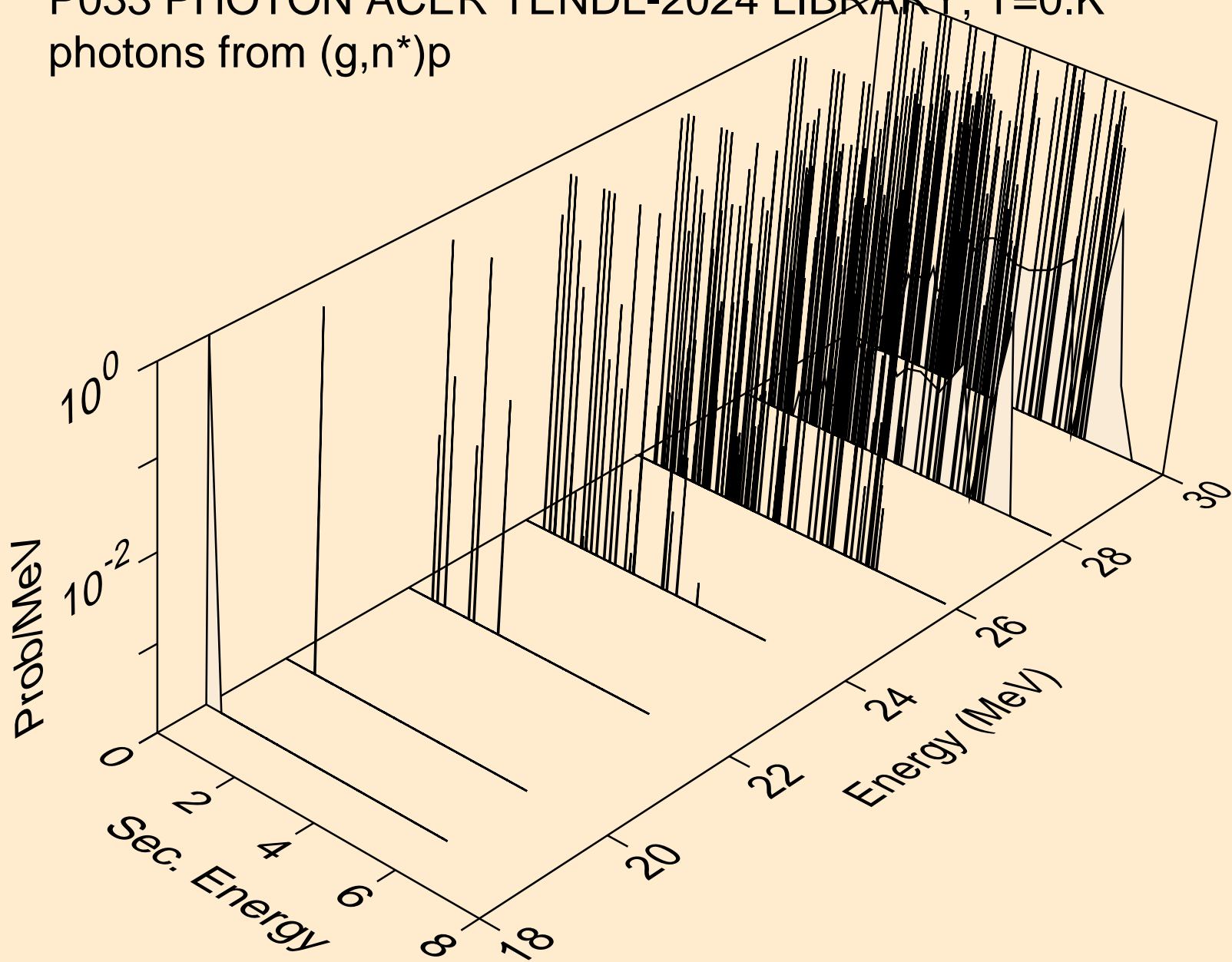

P033 PHOTON ACER TENDL-2024 LIBRARY; T=0.K
photons from (g,n*)d

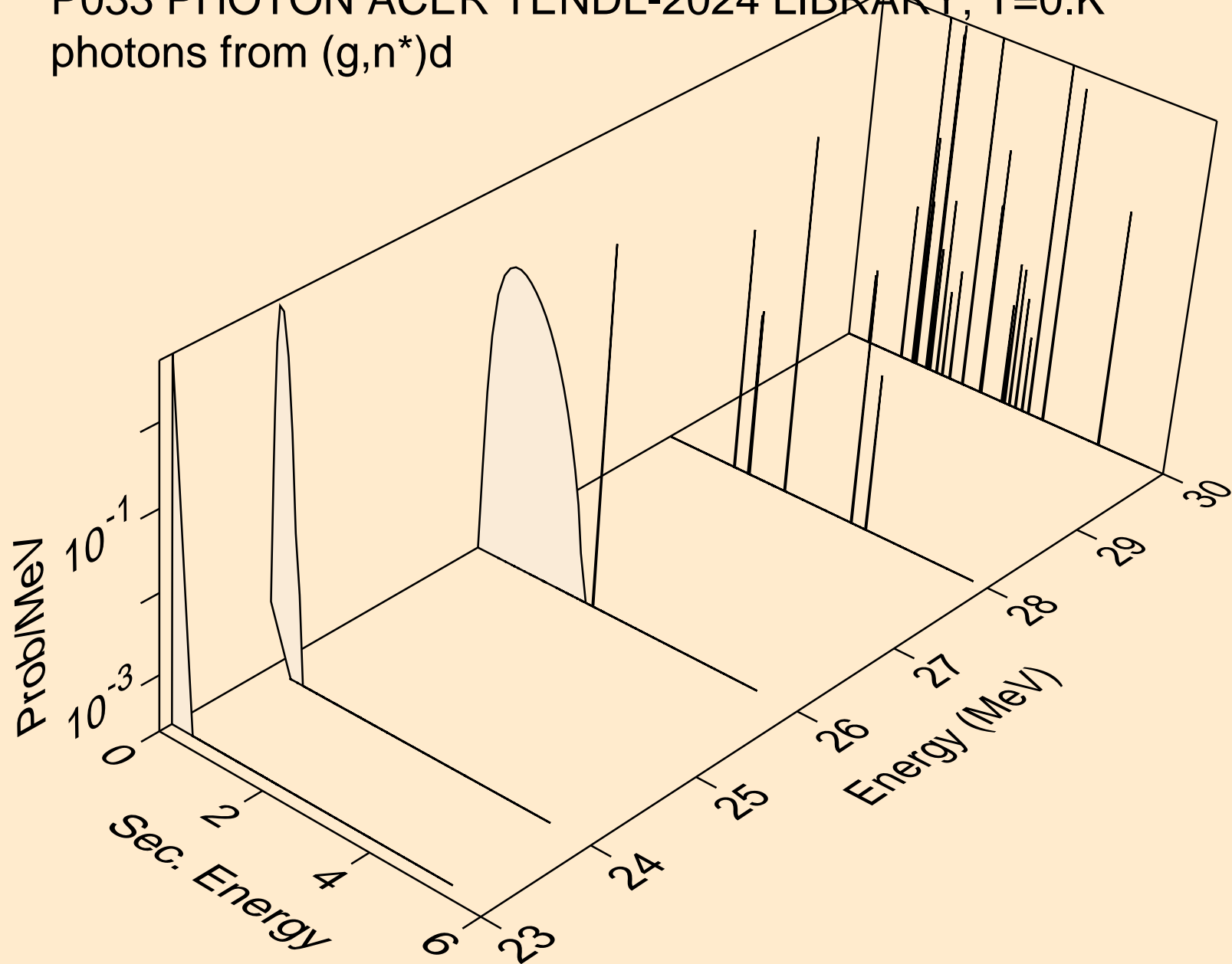

P033 PHOTON ACER TENDL-2024 LIBRARY; T=0.K
photons from (g,n*)t

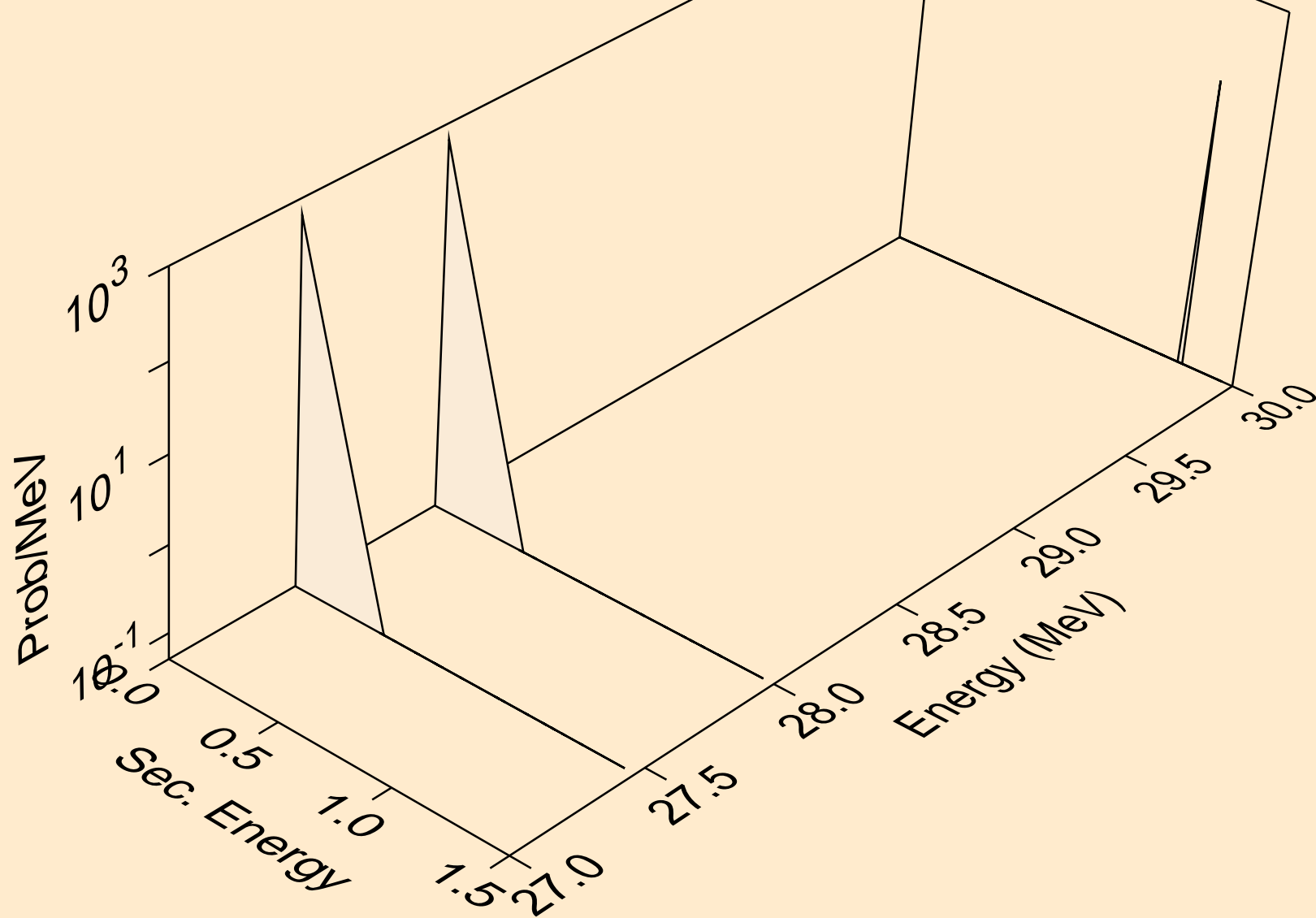

P033 PHOTON ACER TENDL-2024 LIBRARY; T=0.K
photons from (g,2np)

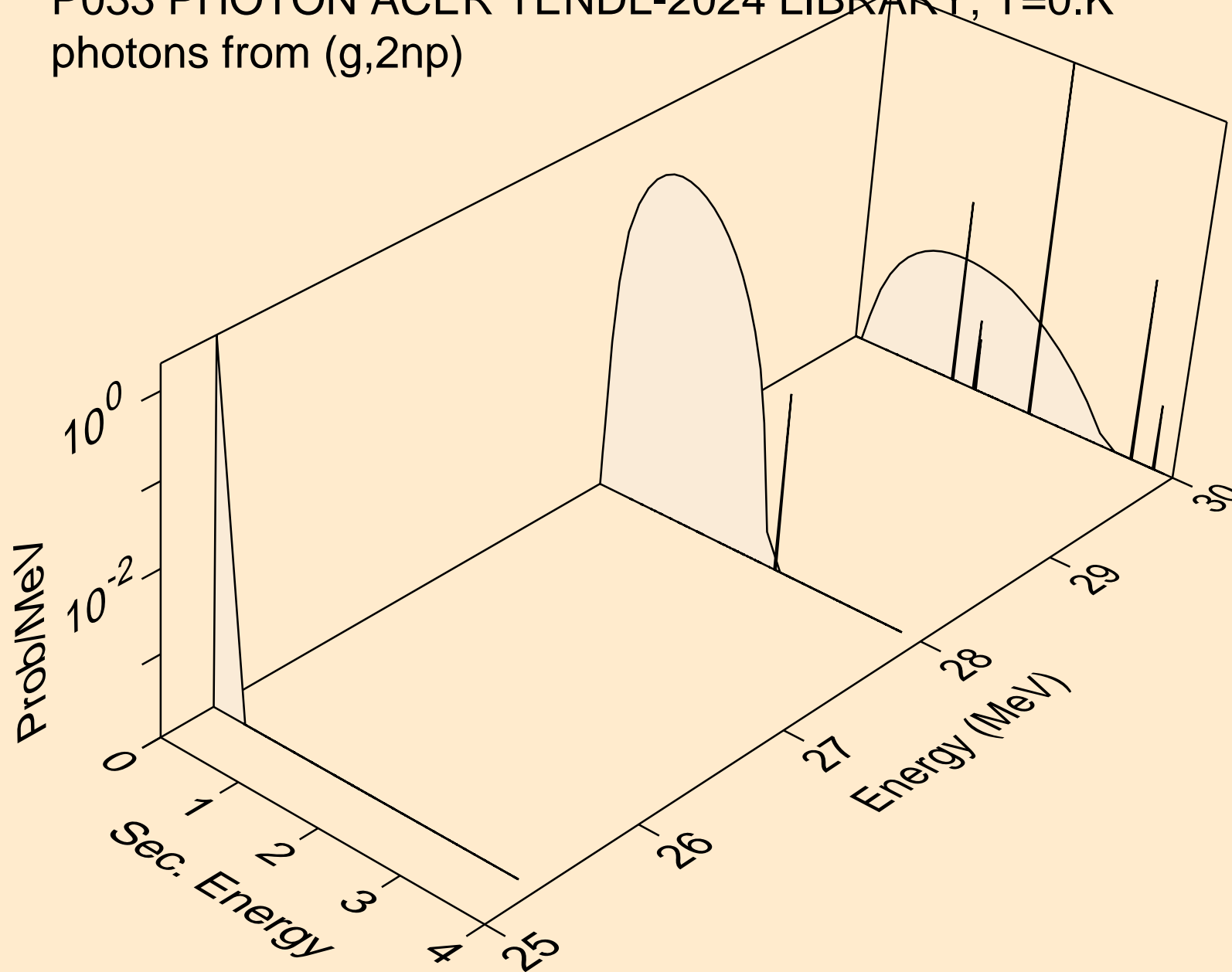

P033 PHOTON ACER TENDL-2024 LIBRARY; T=0.K
photons from (g,n*c)

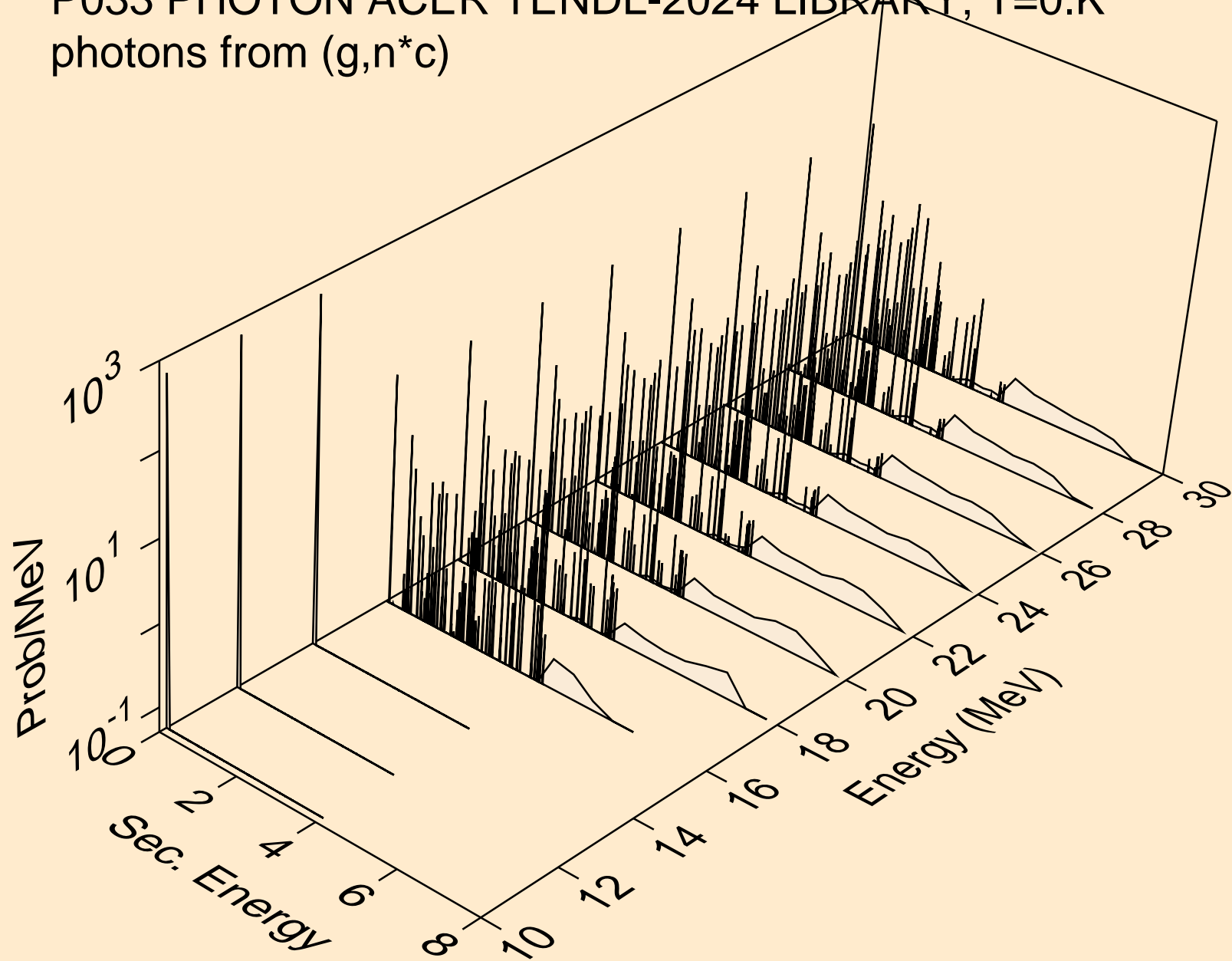

P033 PHOTON ACER TENDL-2024 LIBRARY; T=0.K
photons from (g,gma)

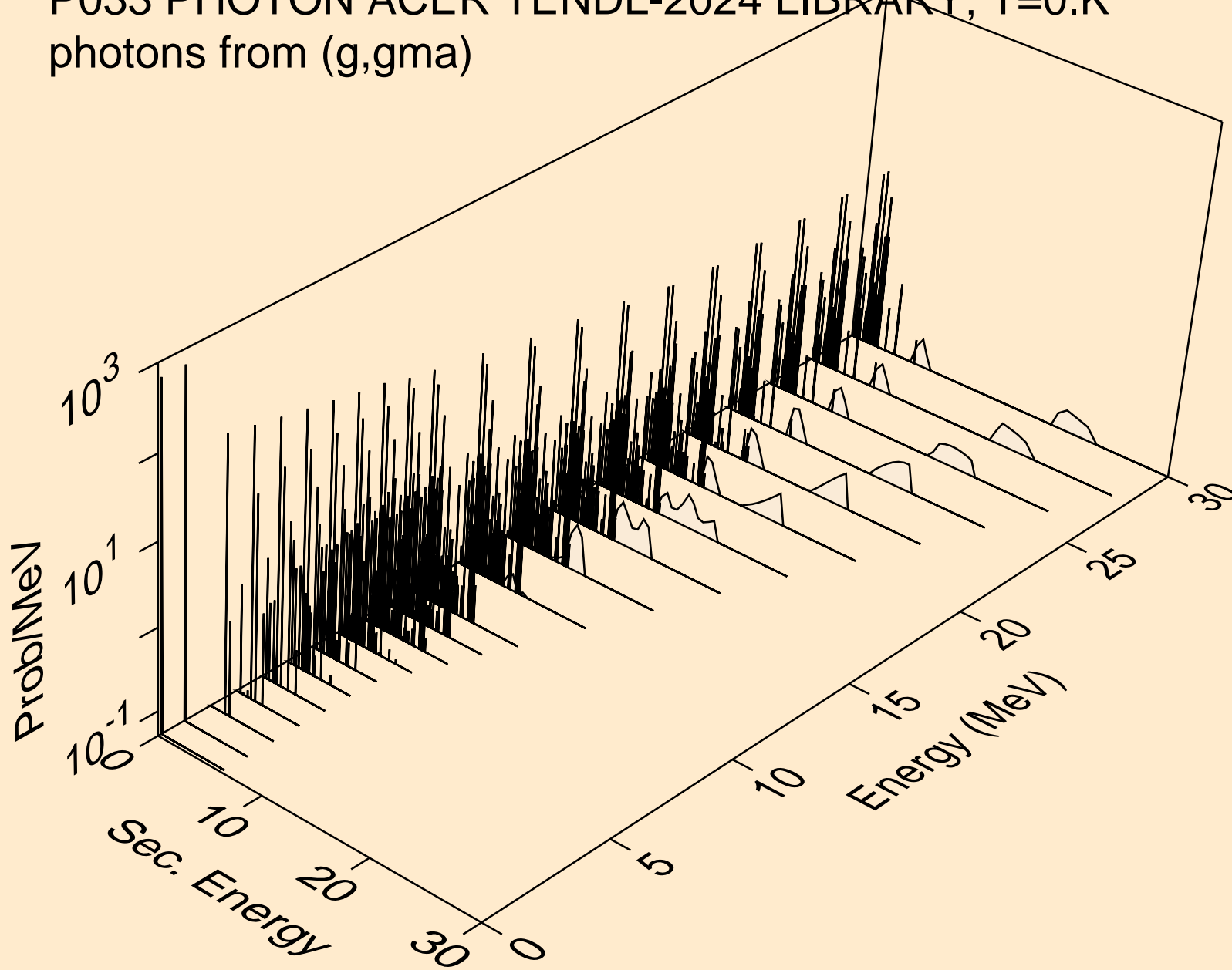

P033 PHOTON ACER TENDL-2024 LIBRARY; T=0.K
photons from (g,p)

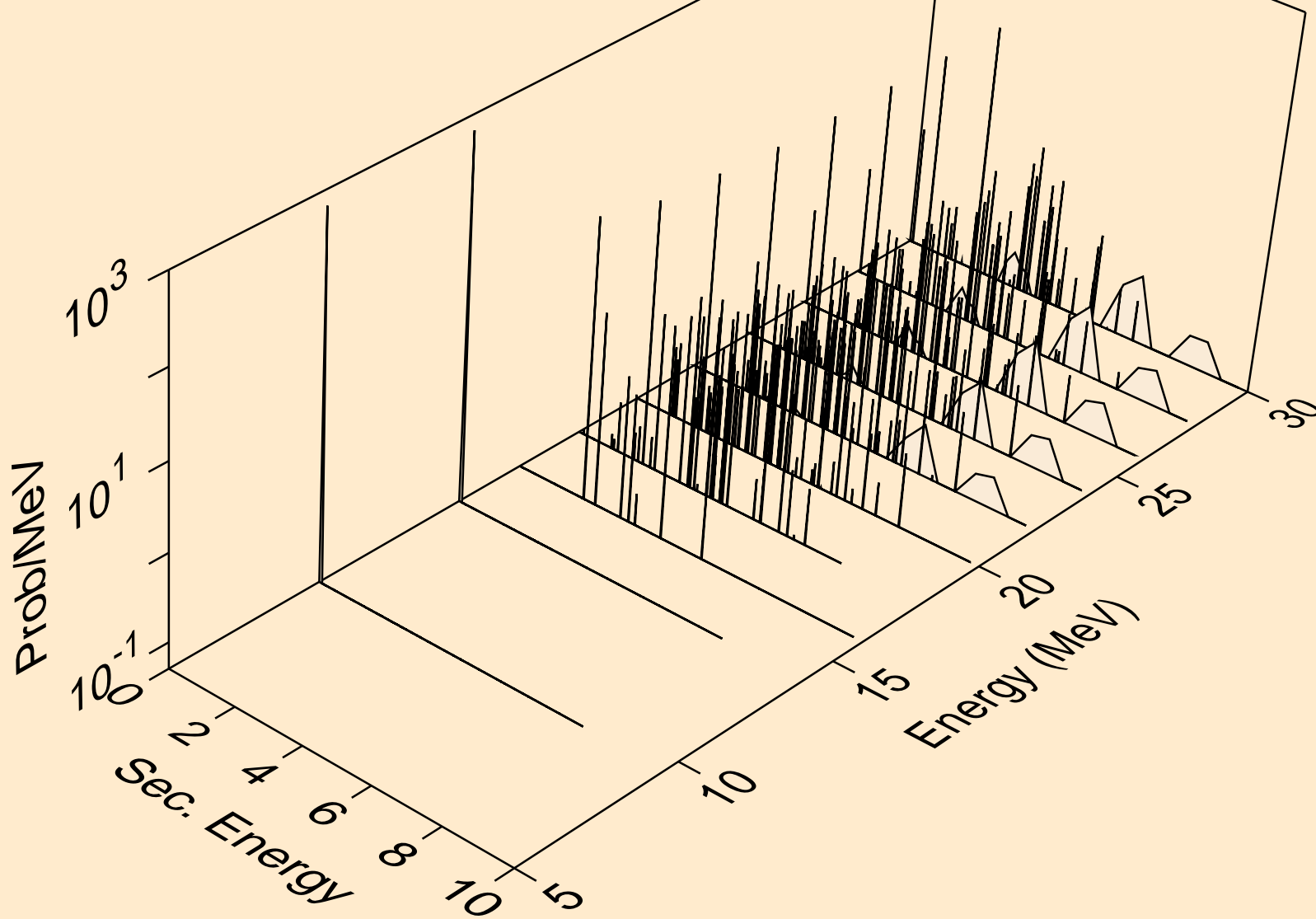

P033 PHOTON ACER TENDL-2024 LIBRARY; T=0.K
photons from (g,d)

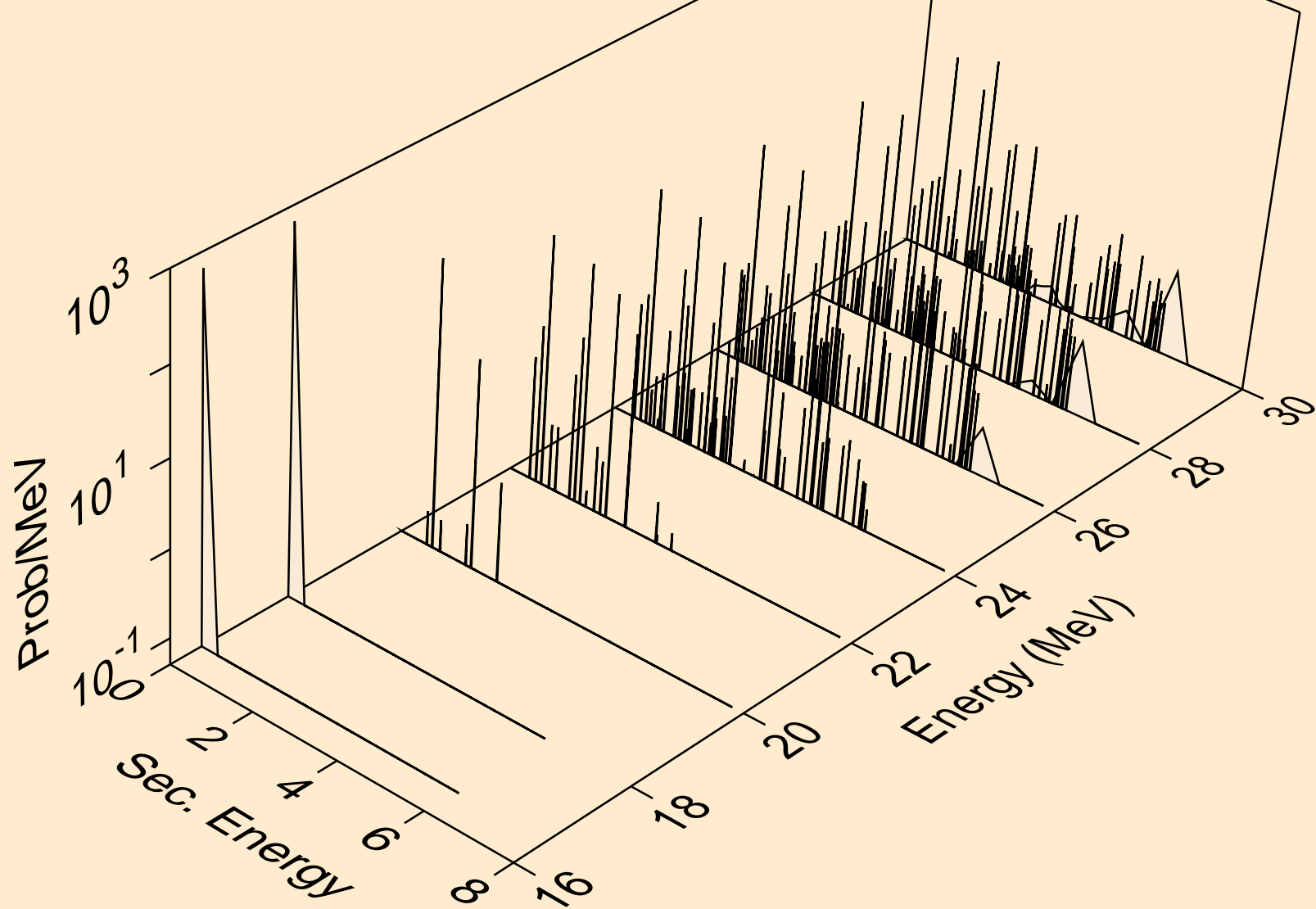

P033 PHOTON ACER TENDL-2024 LIBRARY; T=0.K
photons from (g,t)

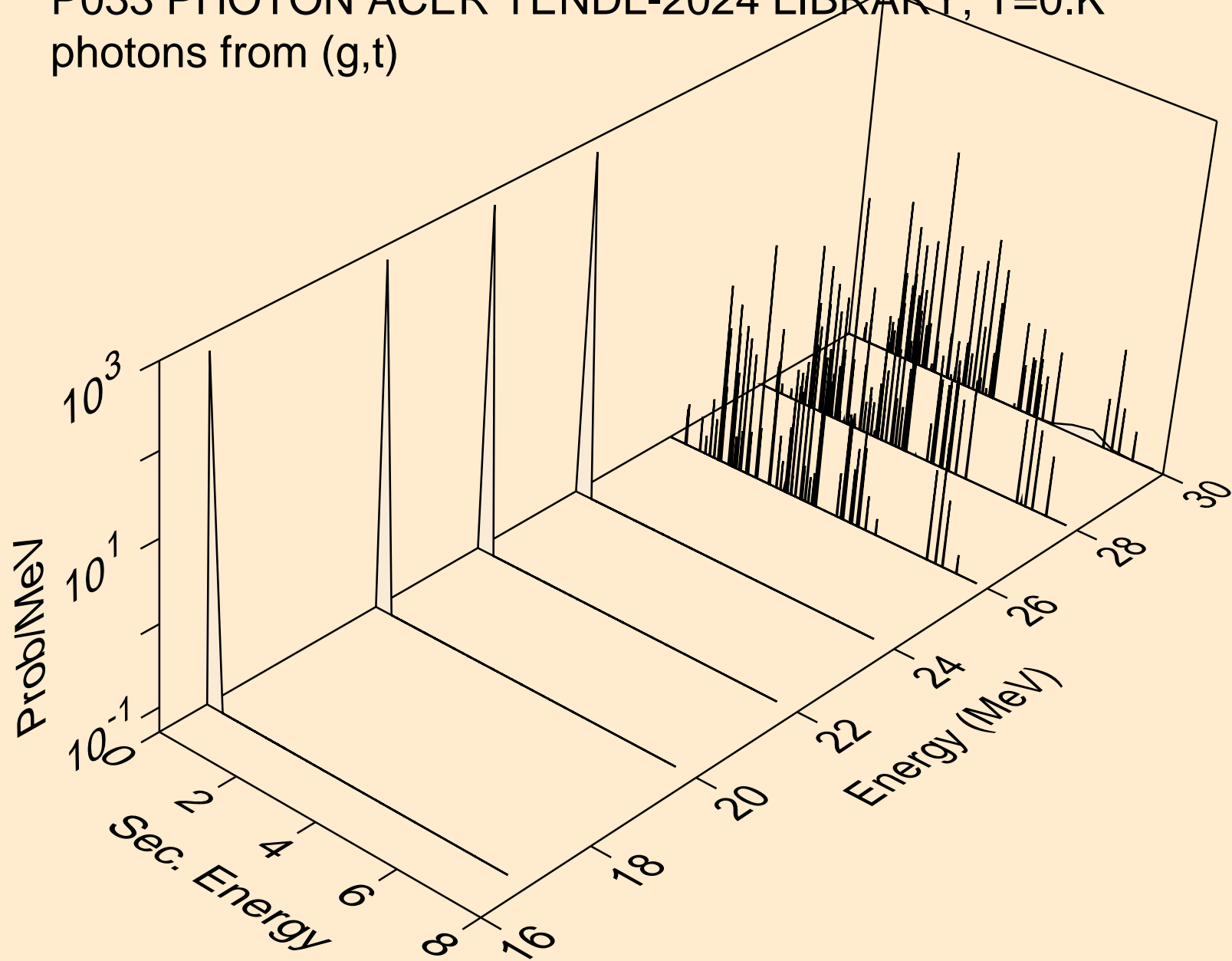

P033 PHOTON ACER TENDL-2024 LIBRARY; T=0.K
photons from (g,he3)

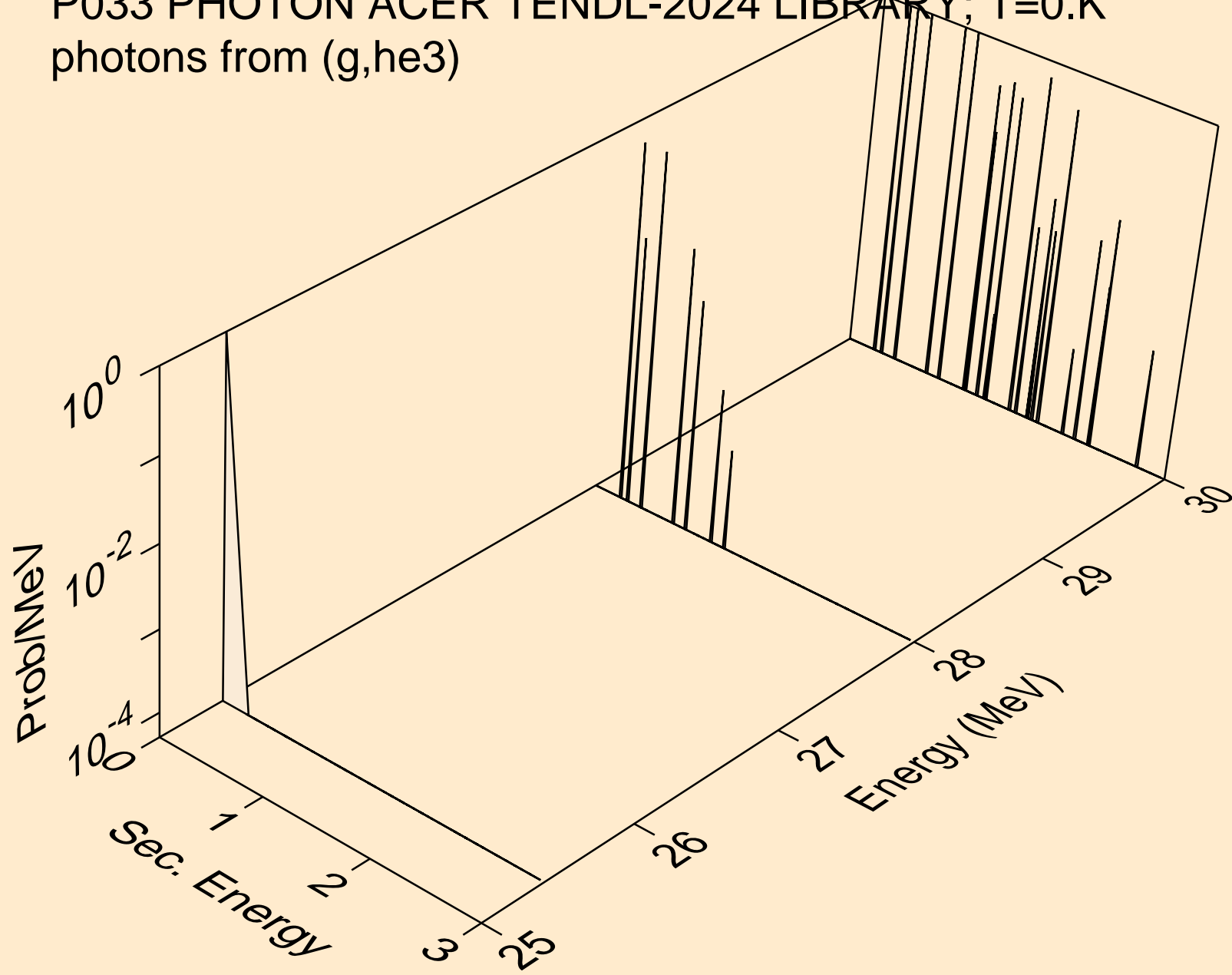

P033 PHOTON ACER TENDL-2024 LIBRARY; T=0.K
photons from (g,a)

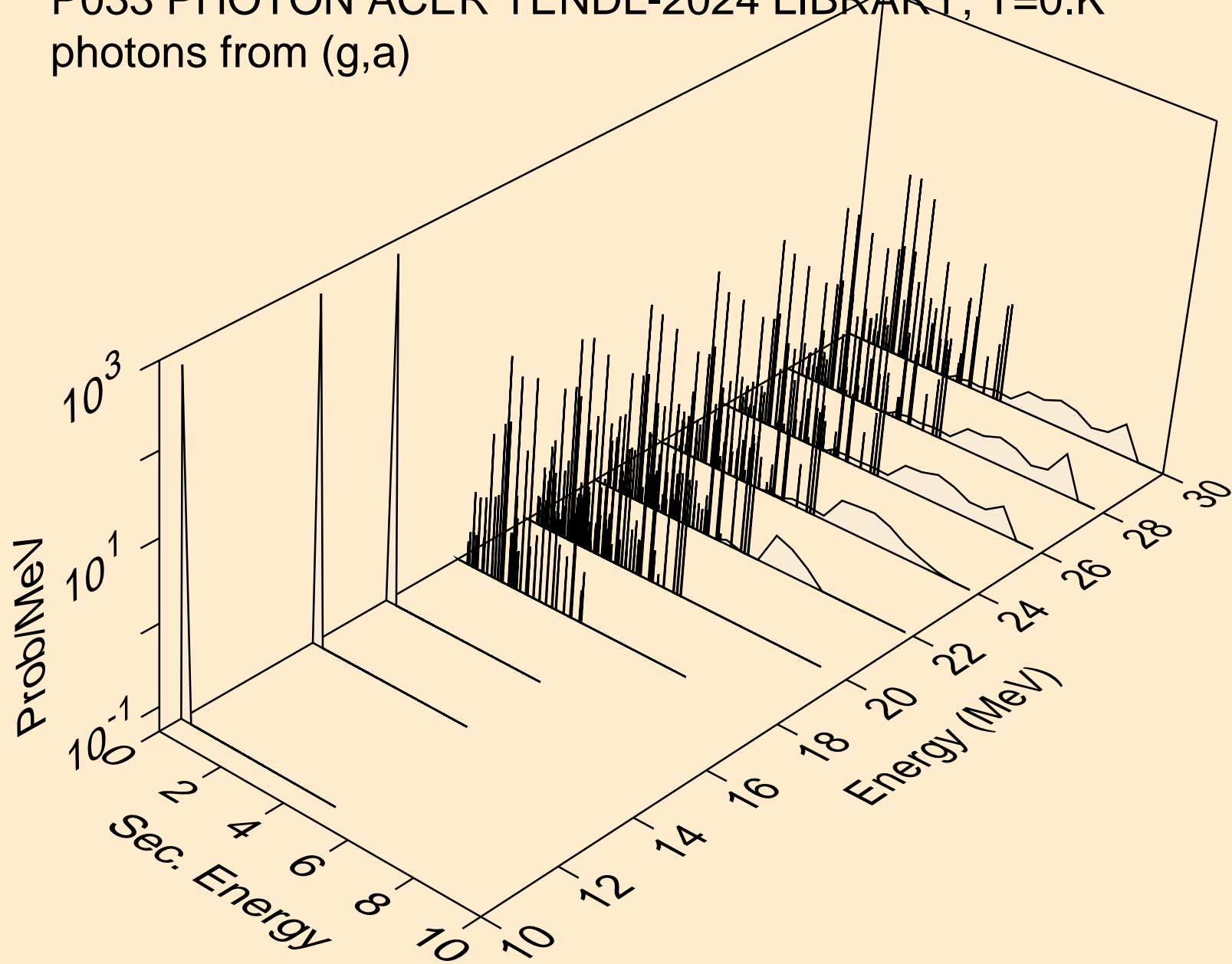

P033 PHOTON ACER TENDL-2024 LIBRARY; T=0.K
photons from (g,2a)

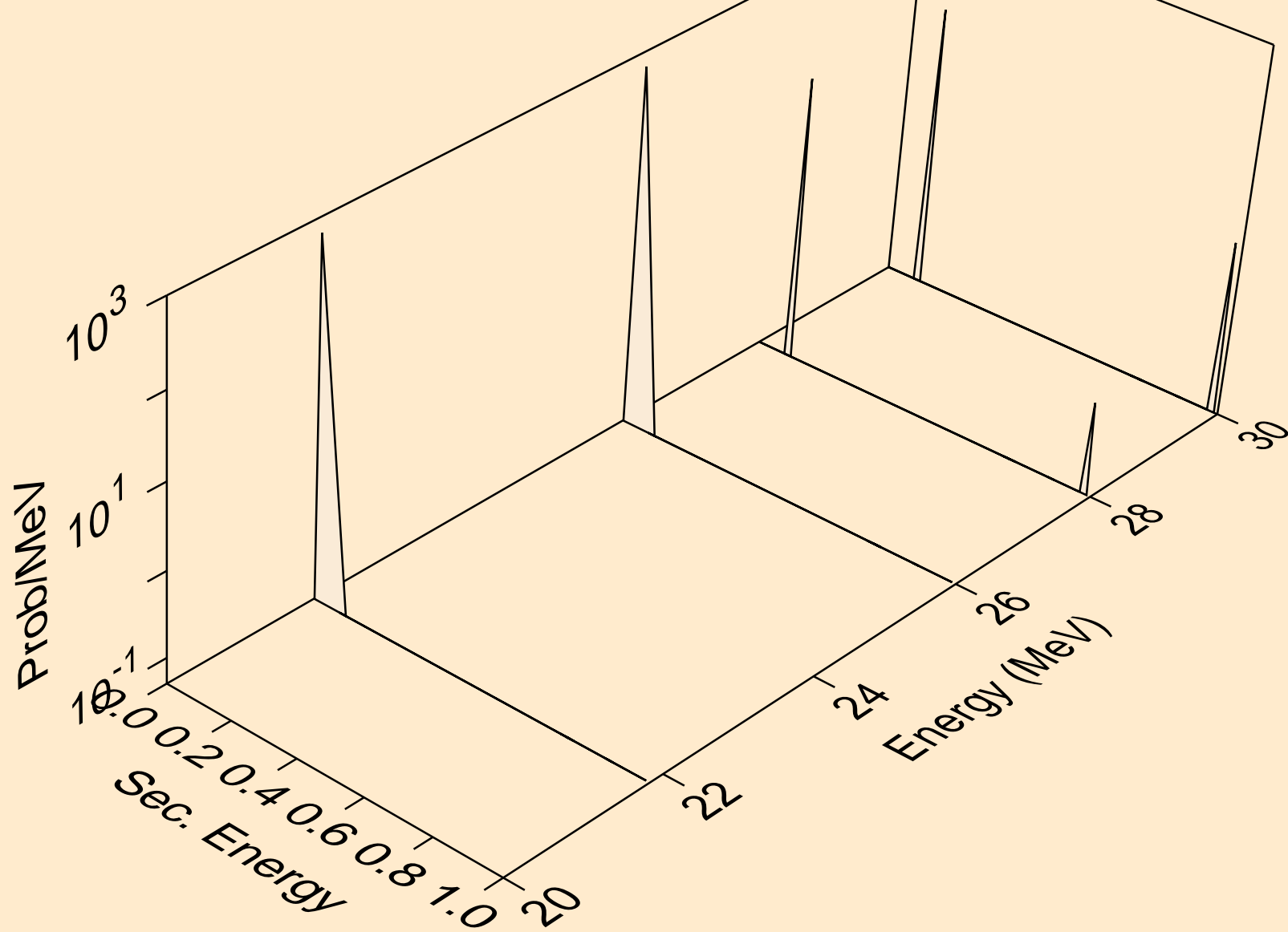

P033 PHOTON ACER TENDL-2024 LIBRARY; T=0.K
photons from (g,2p)

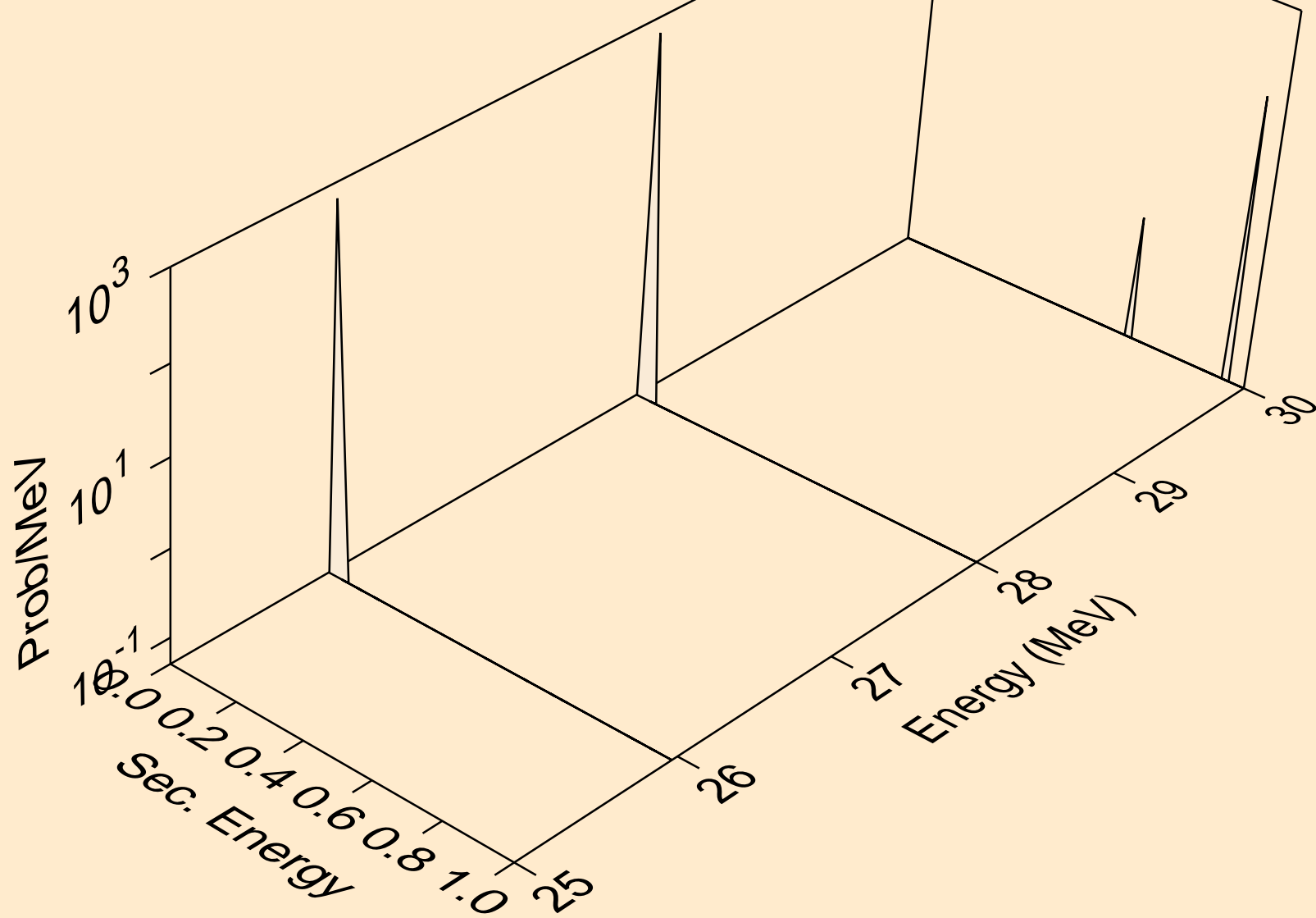

P033 PHOTON ACER TENDL-2024 LIBRARY; T=0.K
photons from (g,pa)

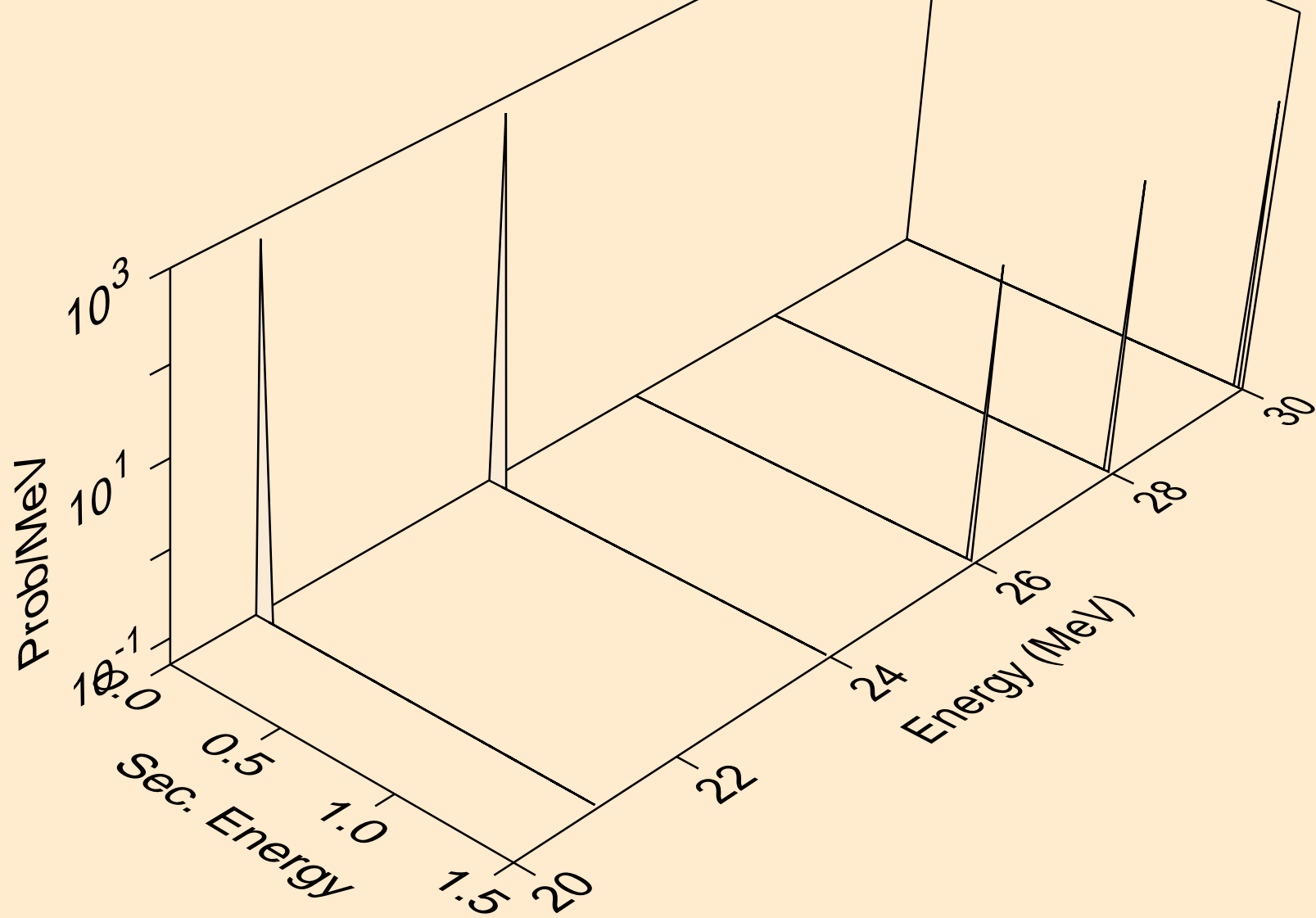

P033 PHOTON ACER TENDL-2024 LIBRARY; T=0.K
protons from (g,x)

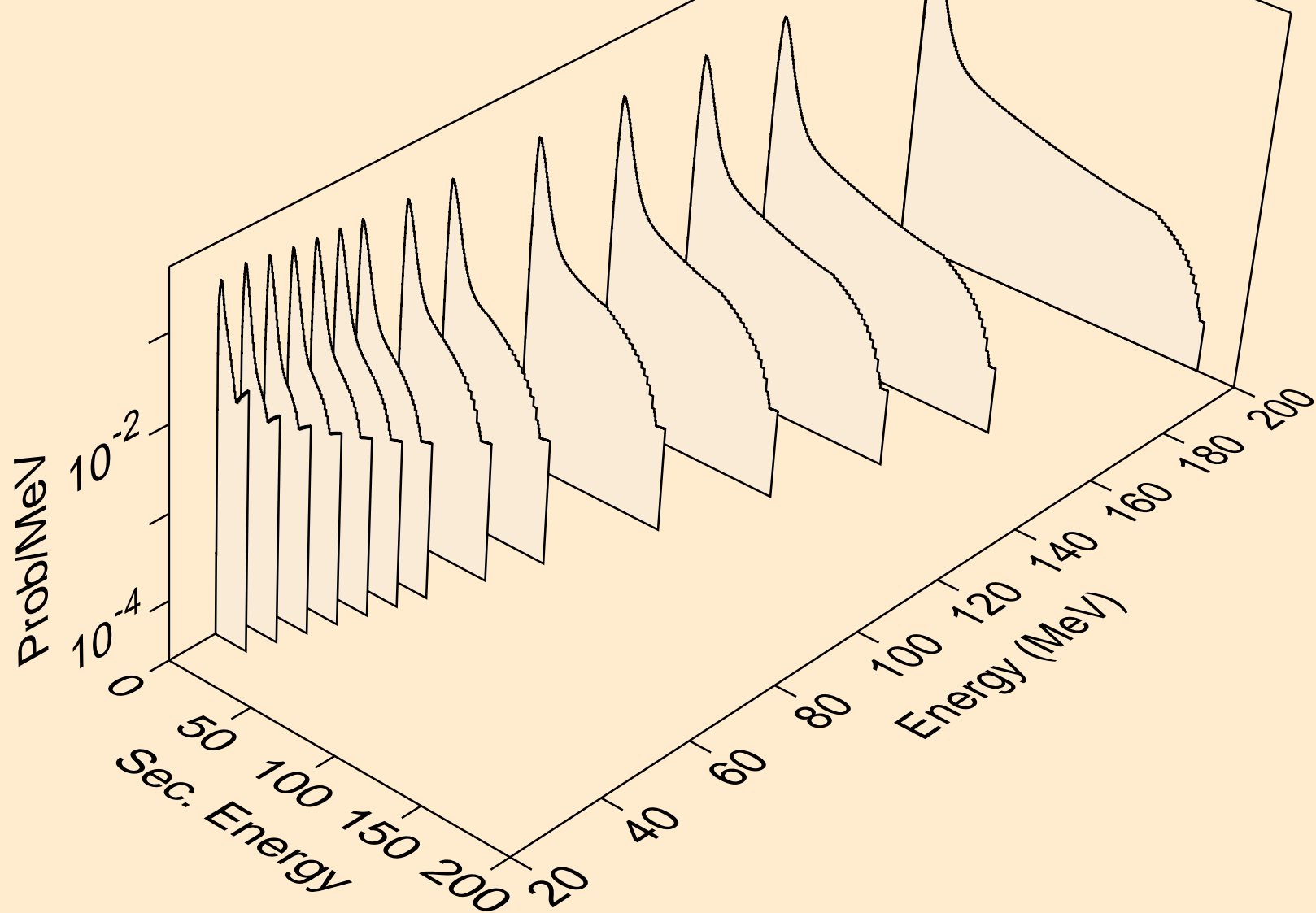

P033 PHOTON ACER TENDL-2024 LIBRARY; T=0.K
protons from (g,n*)p

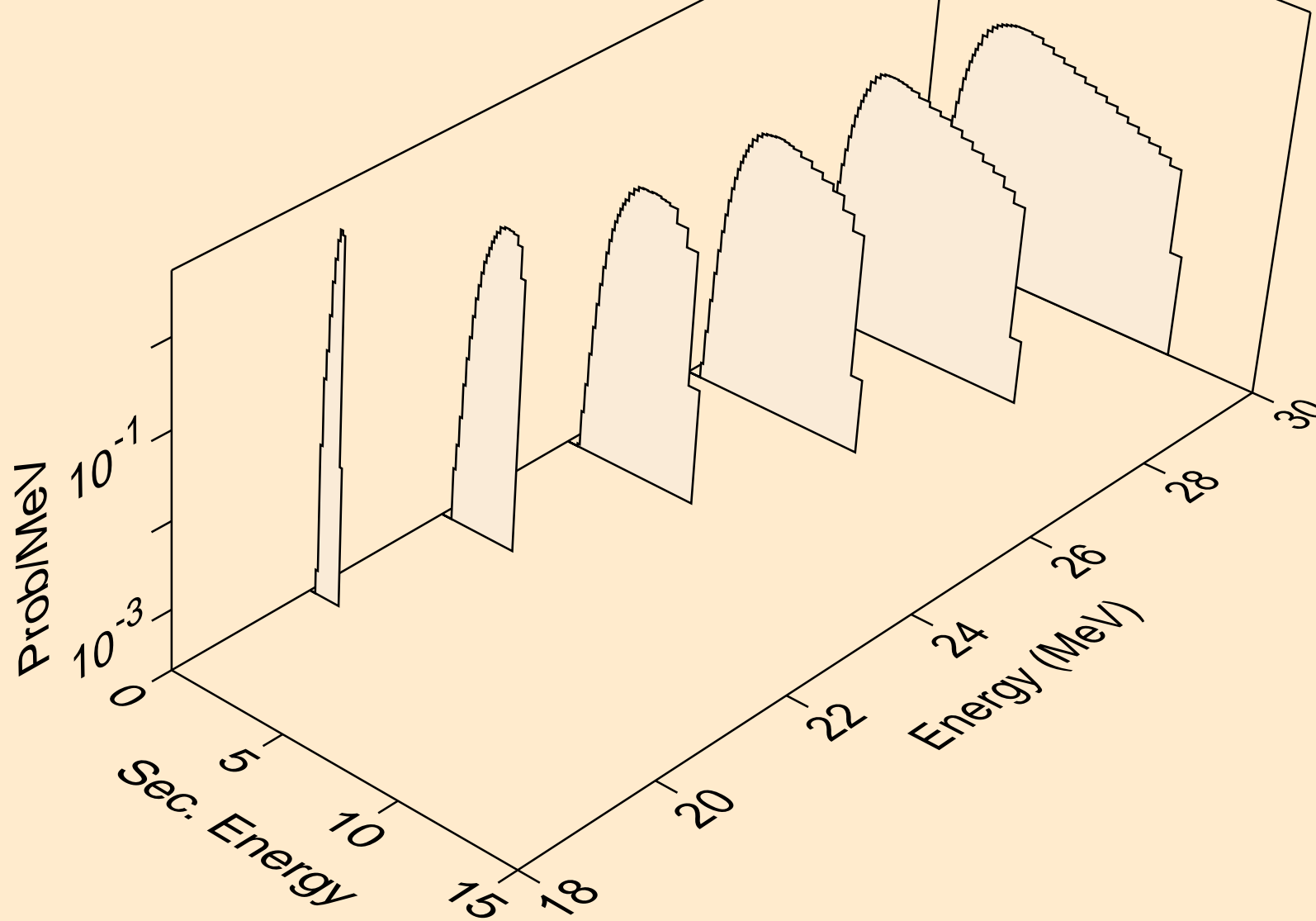

P033 PHOTON ACER TENDL-2024 LIBRARY; T=0.K
protons from (g,2np)

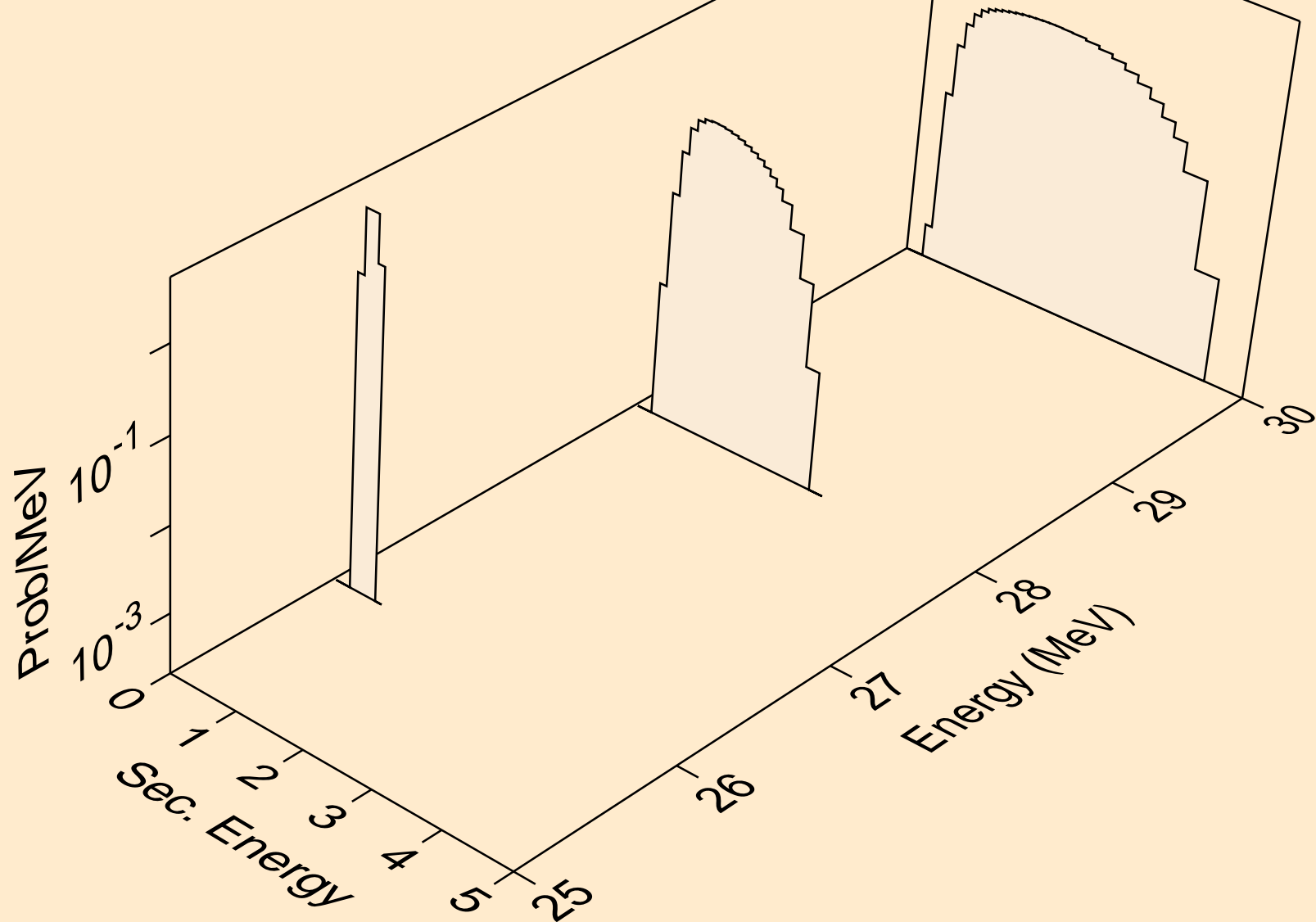

P033 PHOTON ACER TENDL-2024 LIBRARY; T=0.K
protons from (g,p)

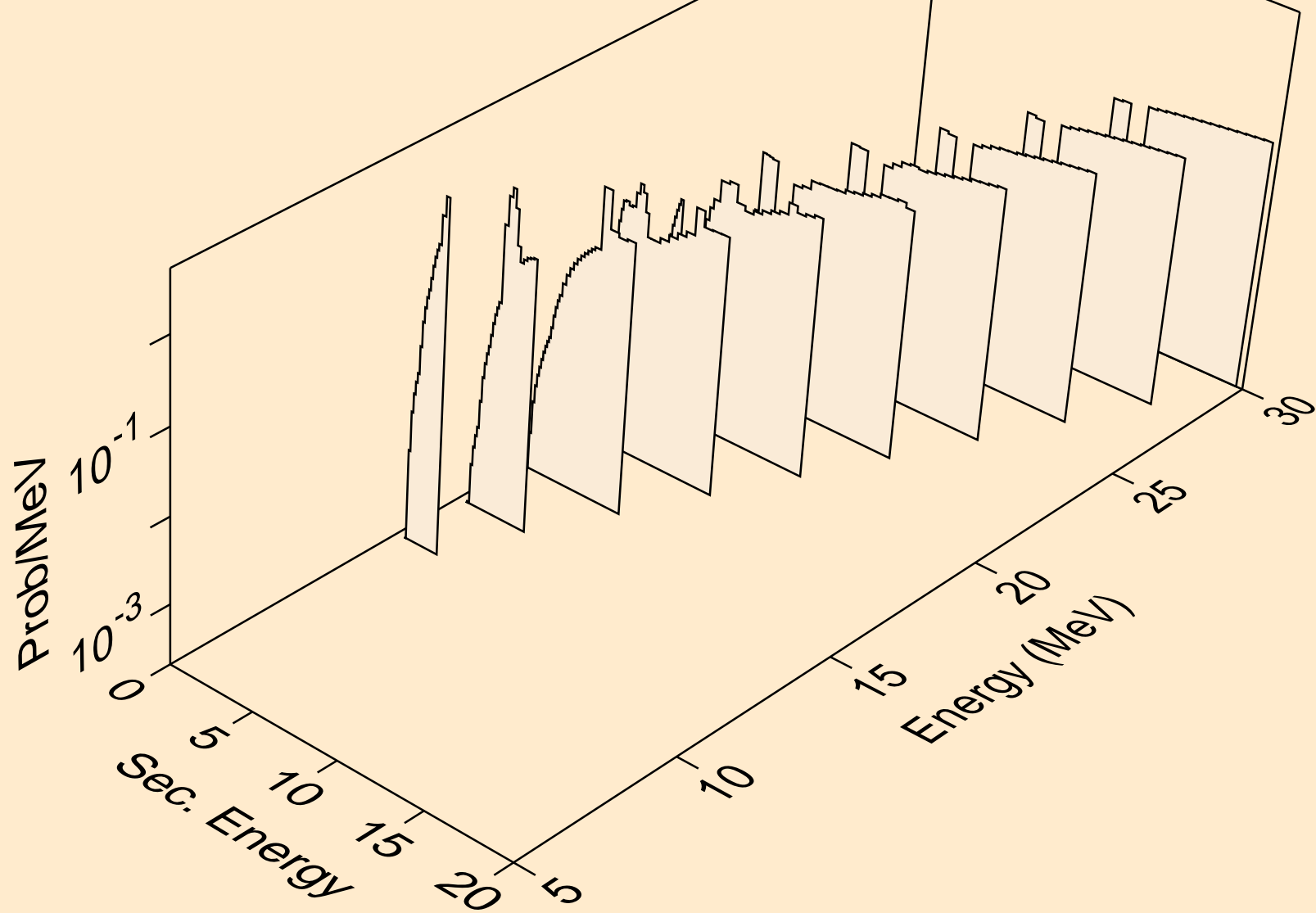

P033 PHOTON ACER TENDL-2024 LIBRARY; T=0.K
protons from (g,2p)

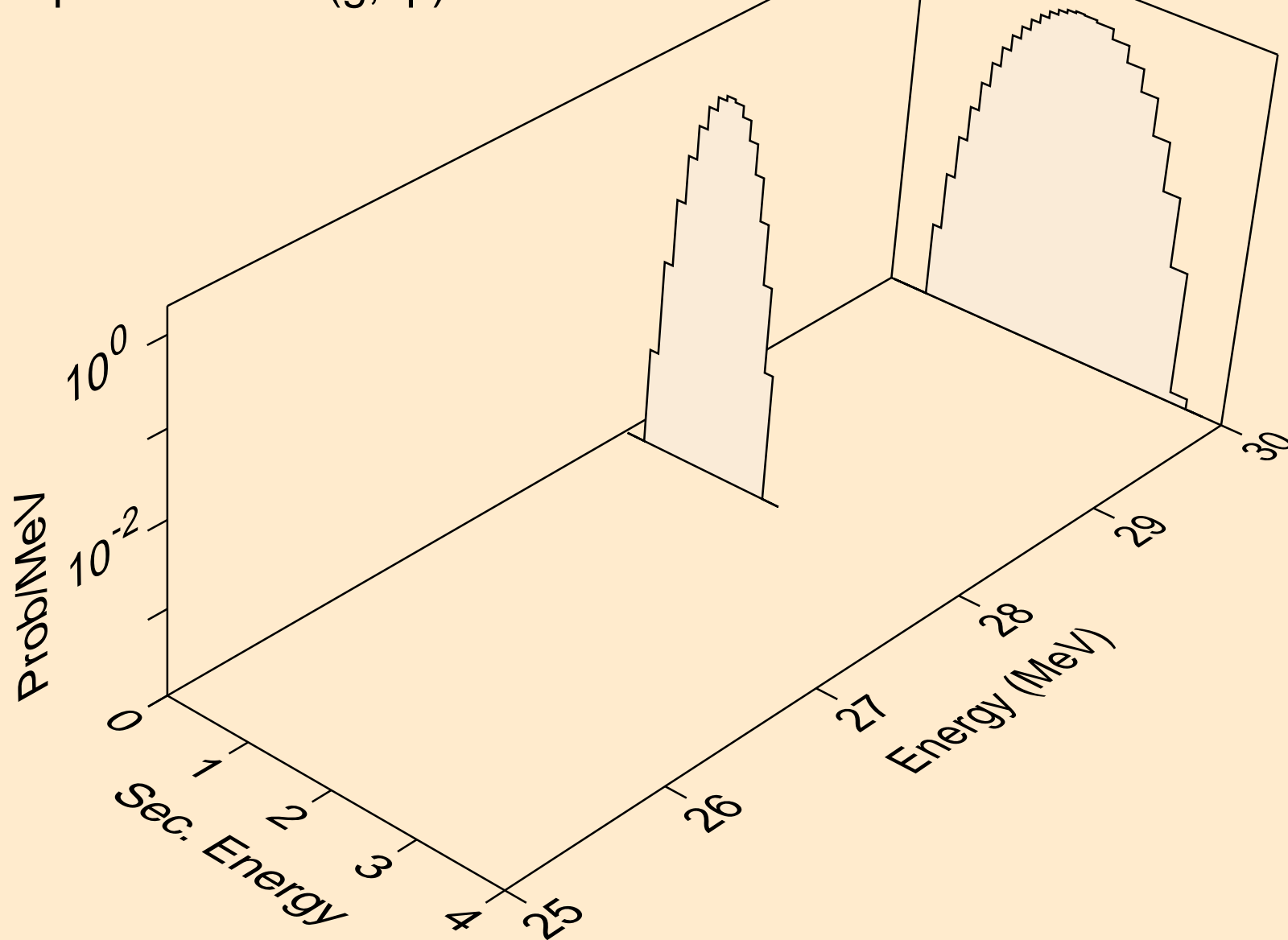

P033 PHOTON ACER TENDL-2024 LIBRARY; T=0.K
protons from (g,pa)

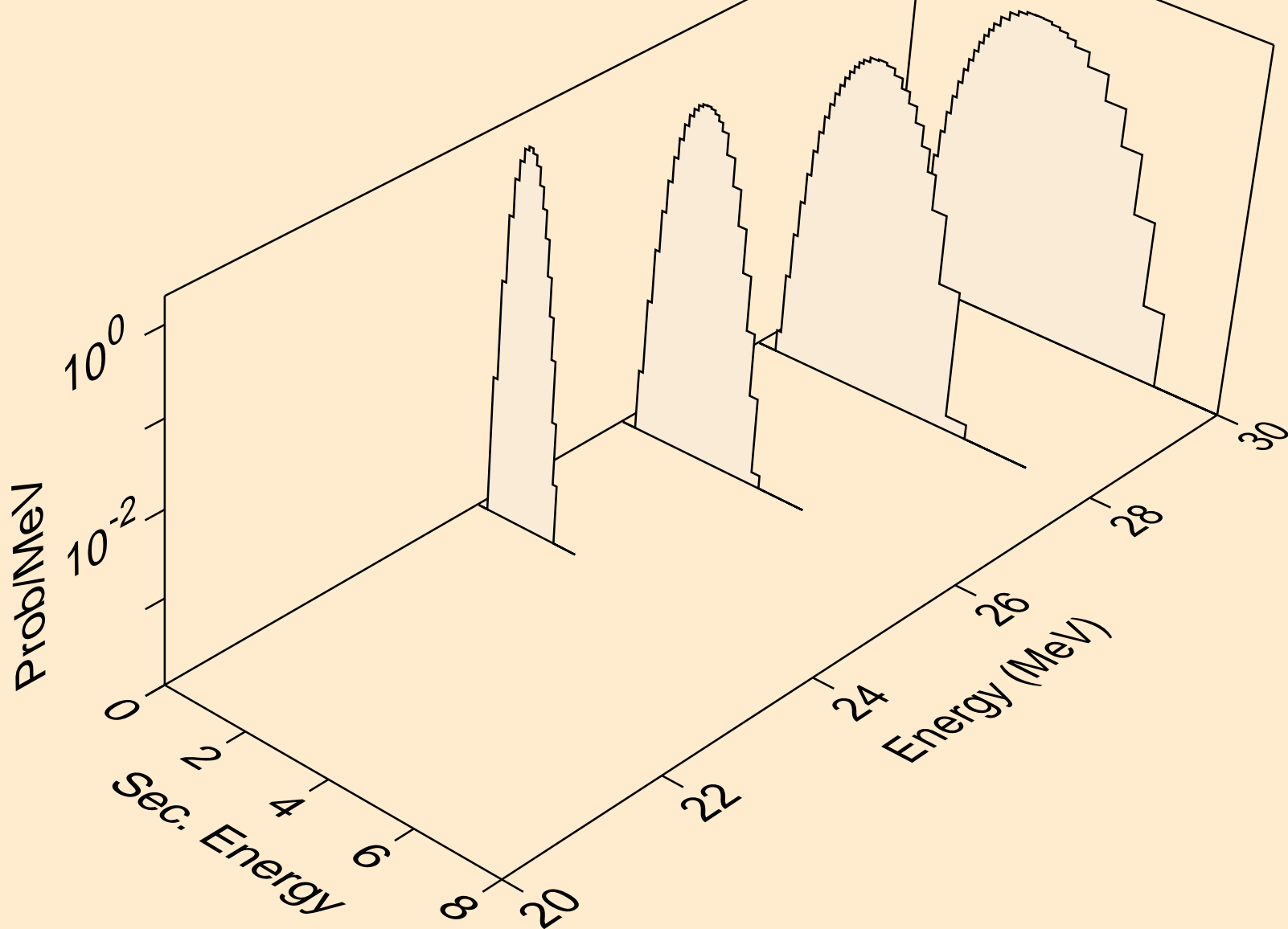

P033 PHOTON ACER TENDL-2024 LIBRARY; T=0.K
deuterons from (g,x)

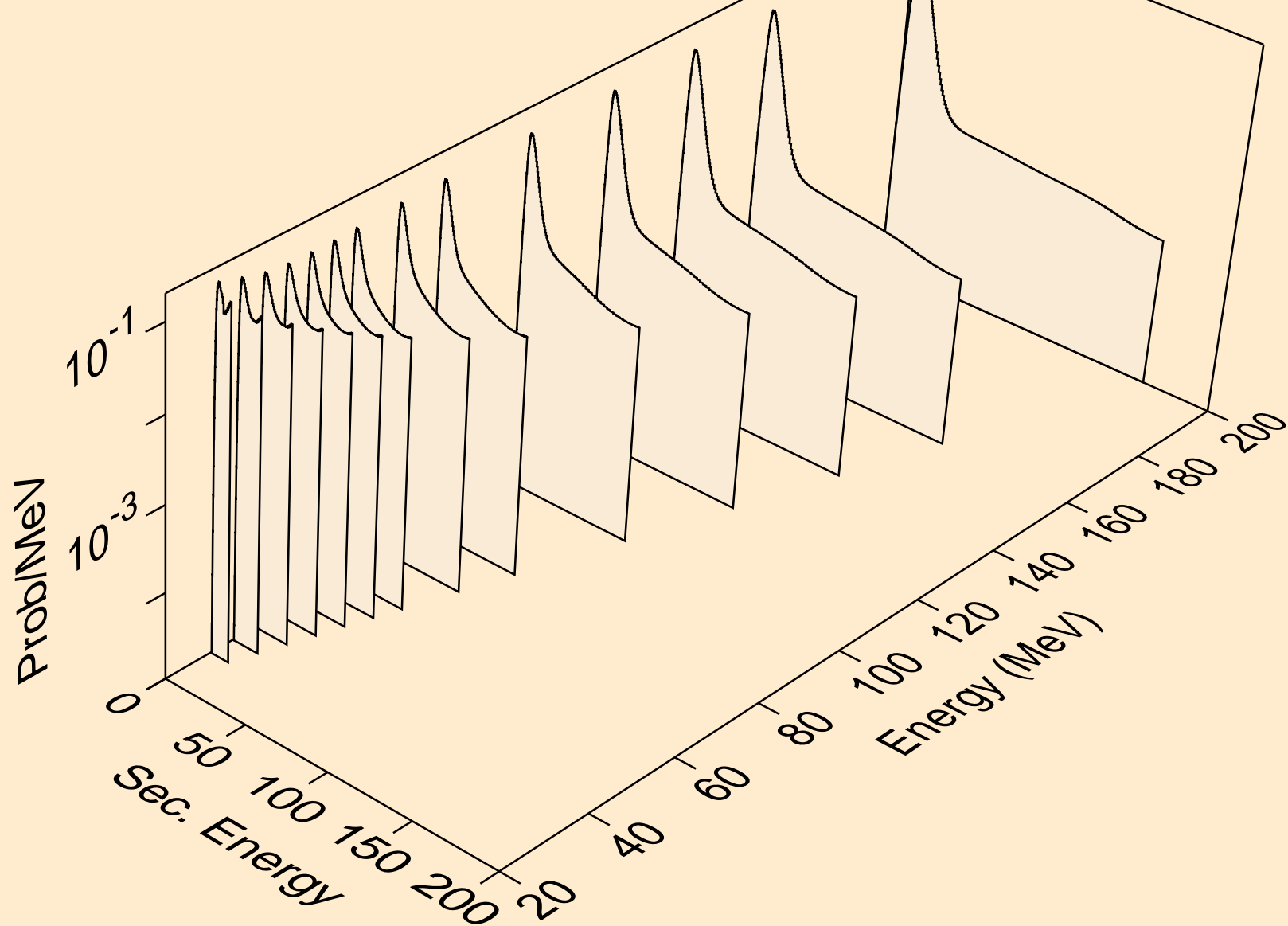

P033 PHOTON ACER TENDL-2024 LIBRARY; T=0.K
deuterons from (g,n*)d

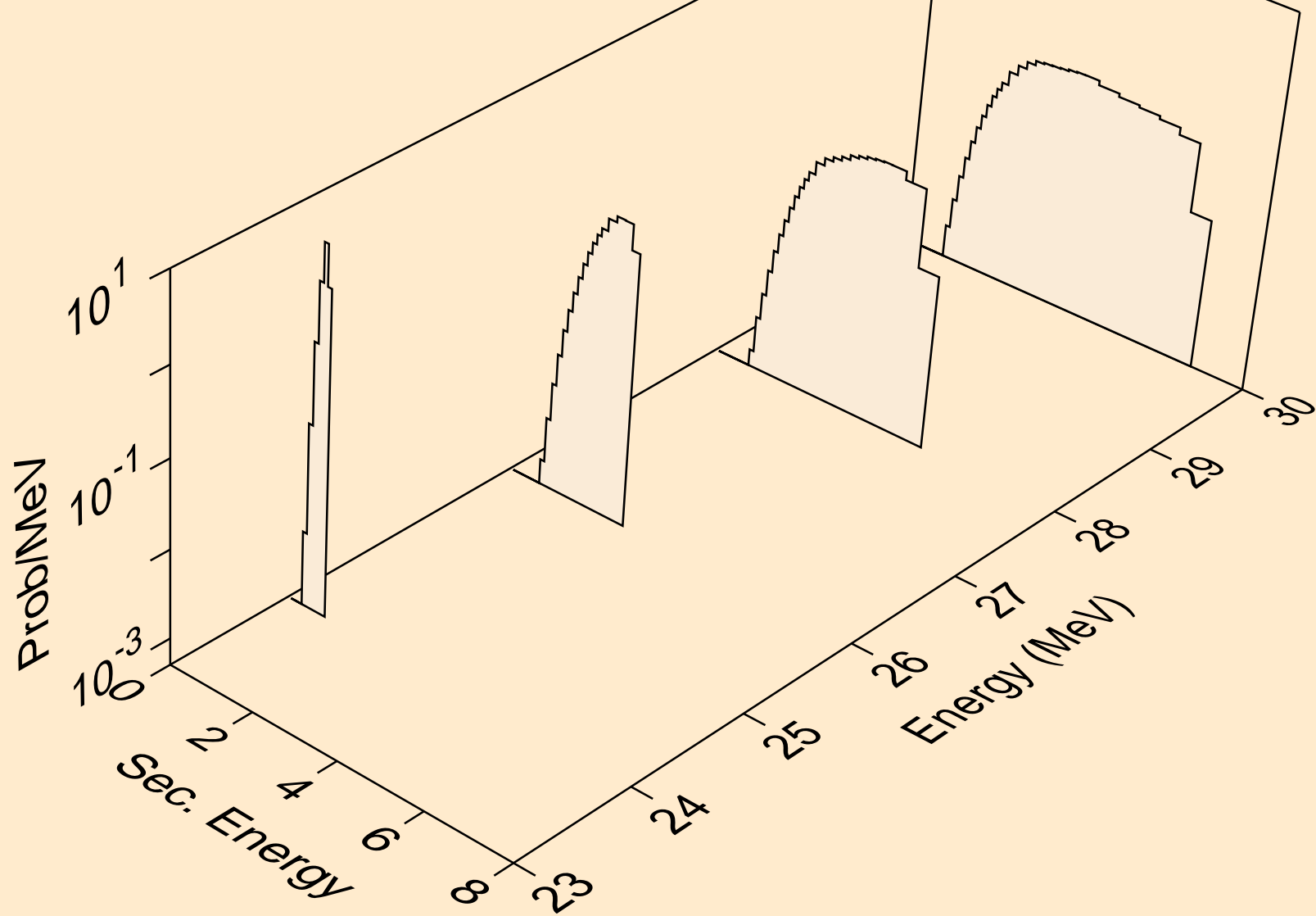

P033 PHOTON ACER TENDL-2024 LIBRARY; T=0.K
deuterons from (g,d)

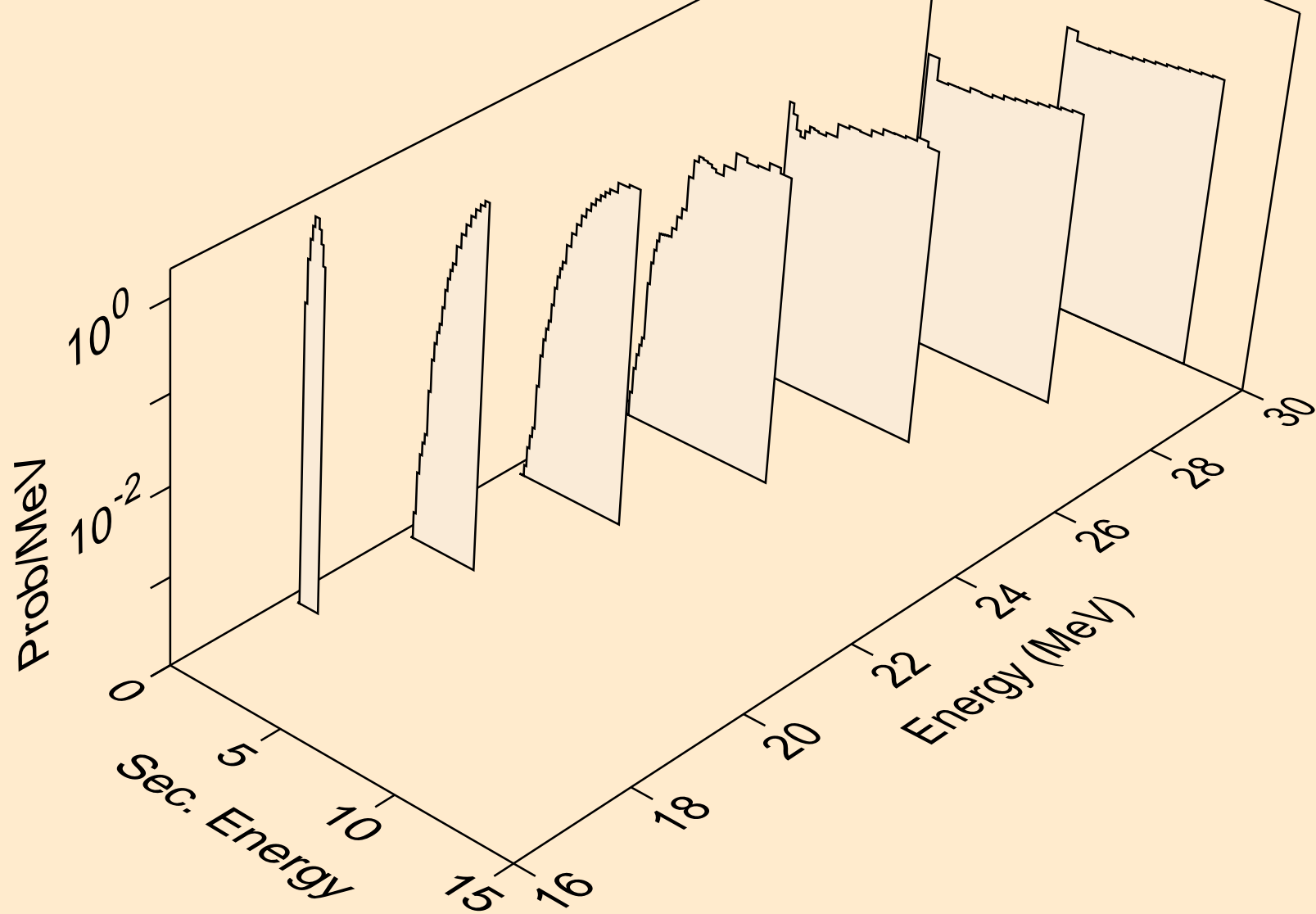

P033 PHOTON ACER TENDL-2024 LIBRARY; T=0.K
tritons from (g,x)

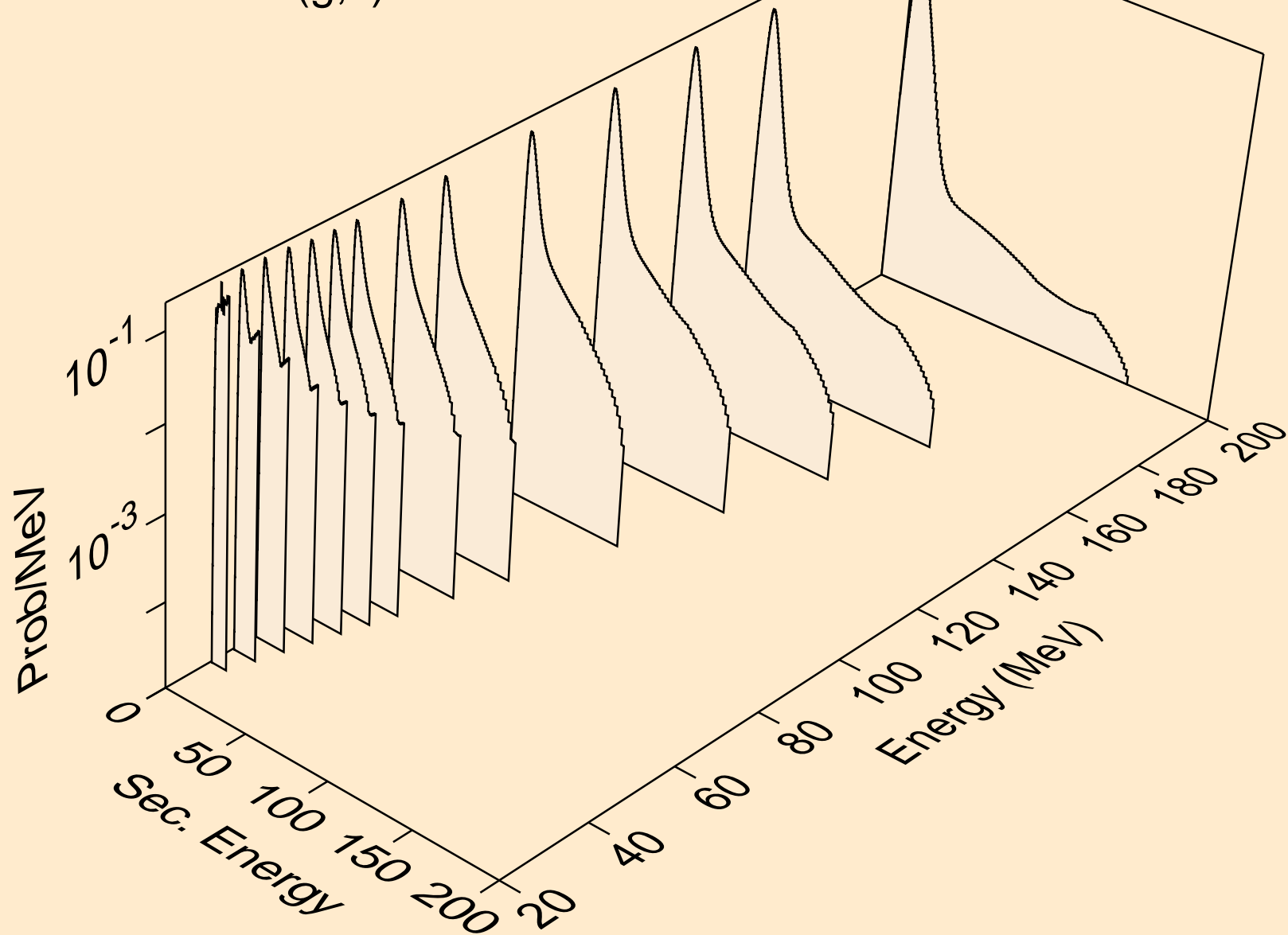

P033 PHOTON ACER TENDL-2024 LIBRARY; T=0.K
tritons from (g,n*)t

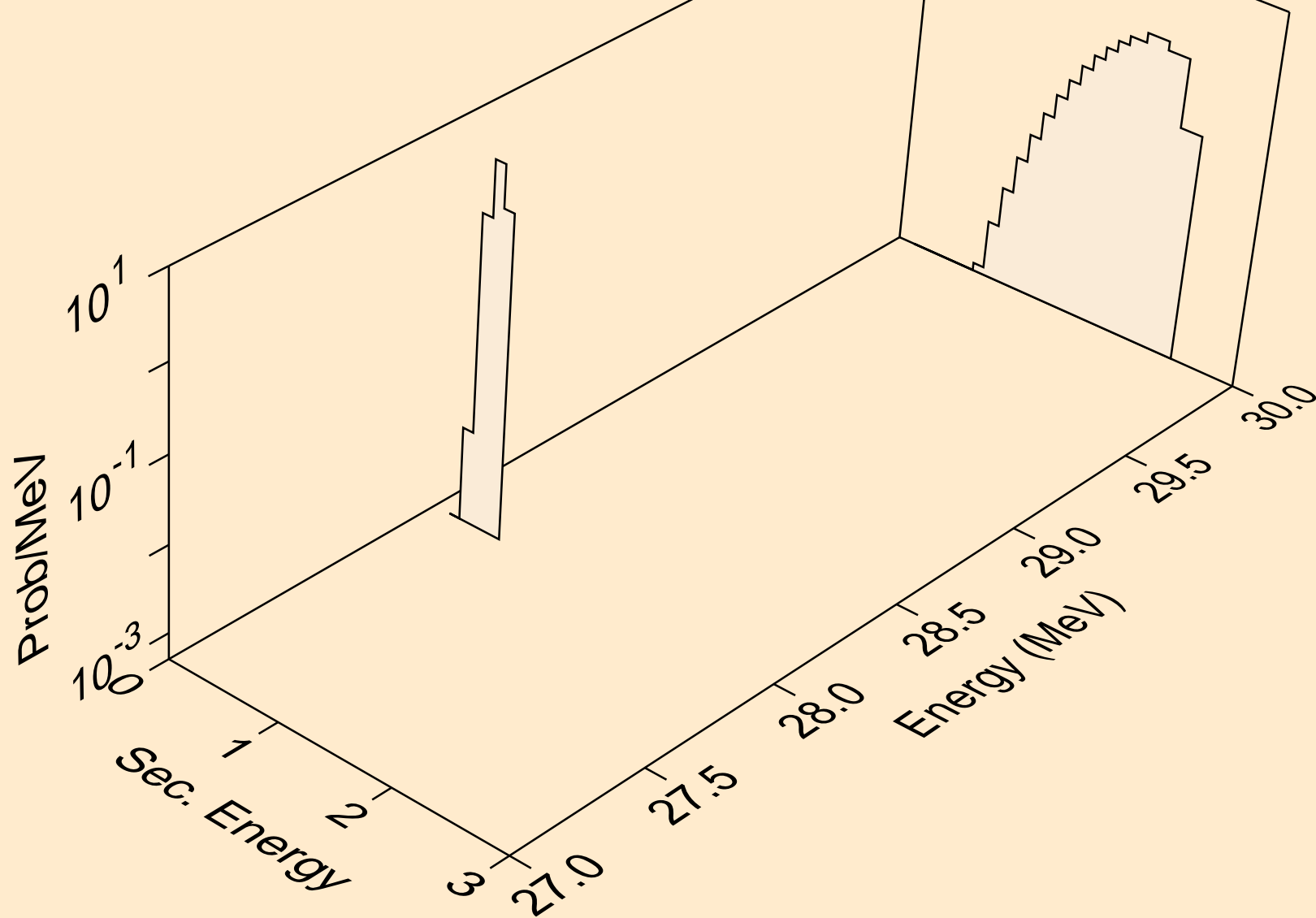

P033 PHOTON ACER TENDL-2024 LIBRARY; T=0.K
tritons from (g,t)

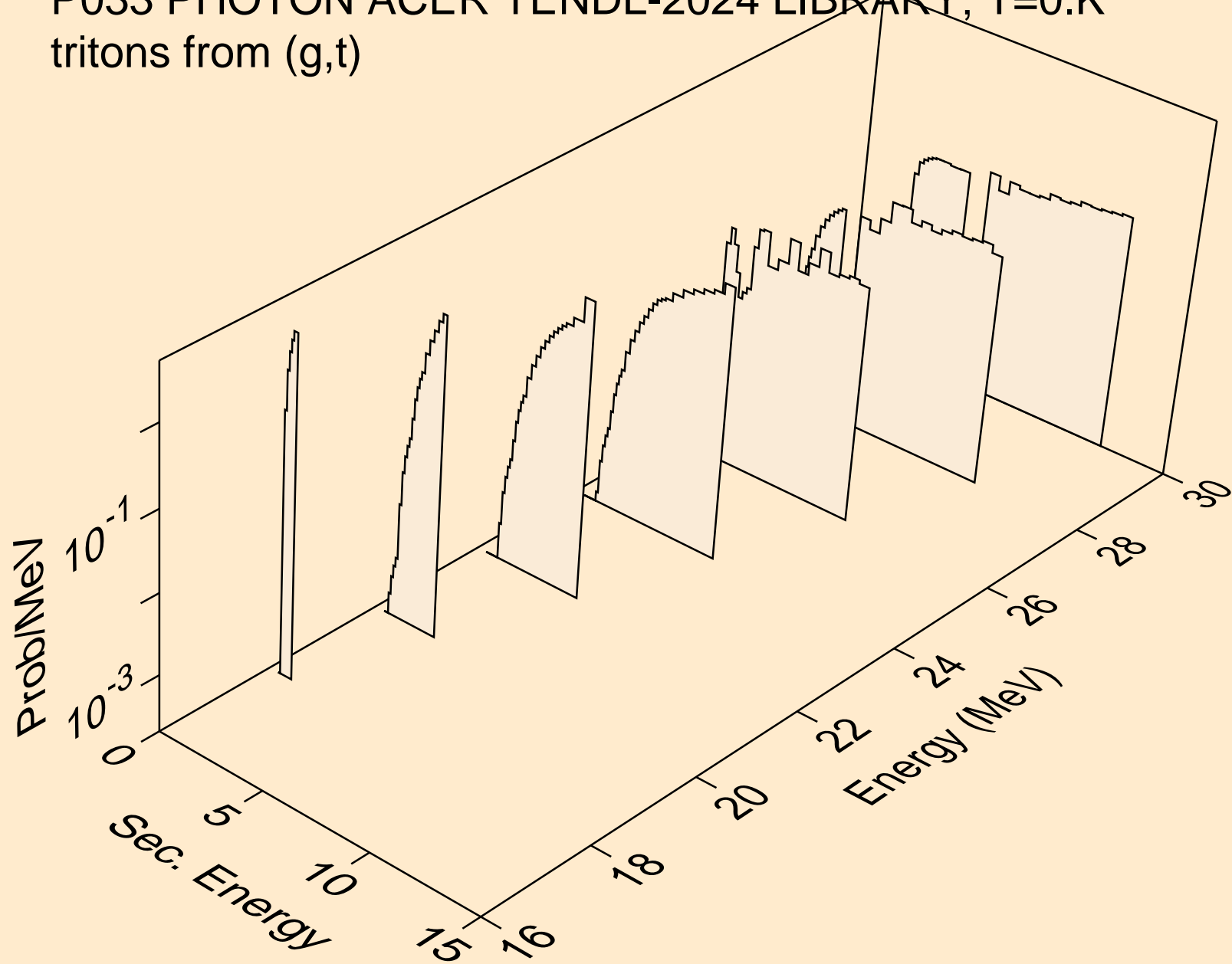

P033 PHOTON ACER TENDL-2024 LIBRARY; T=0.K
he3s from (g,x)

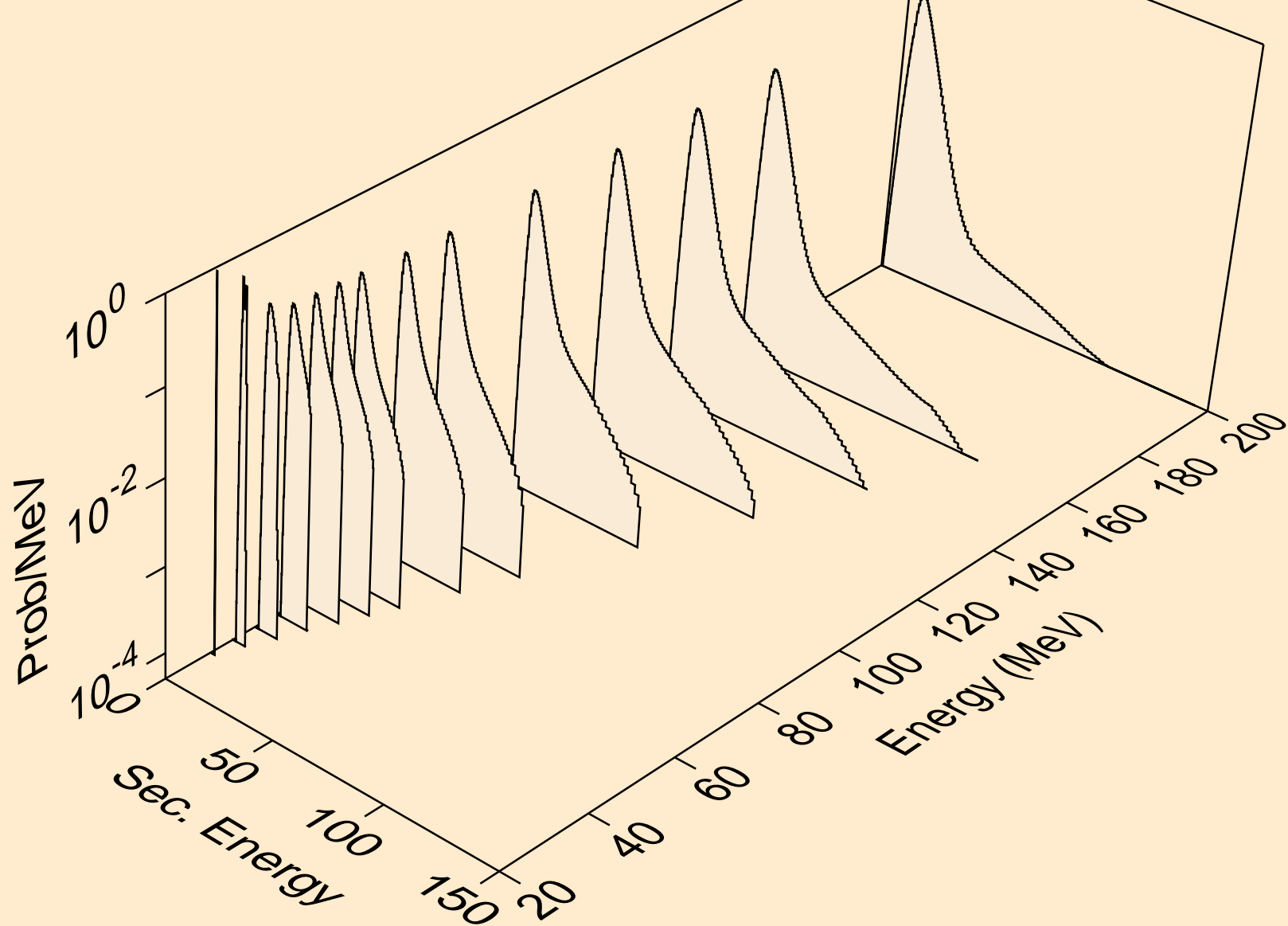

P033 PHOTON ACER TENDL-2024 LIBRARY; T=0.K
he3s from (g,he3)

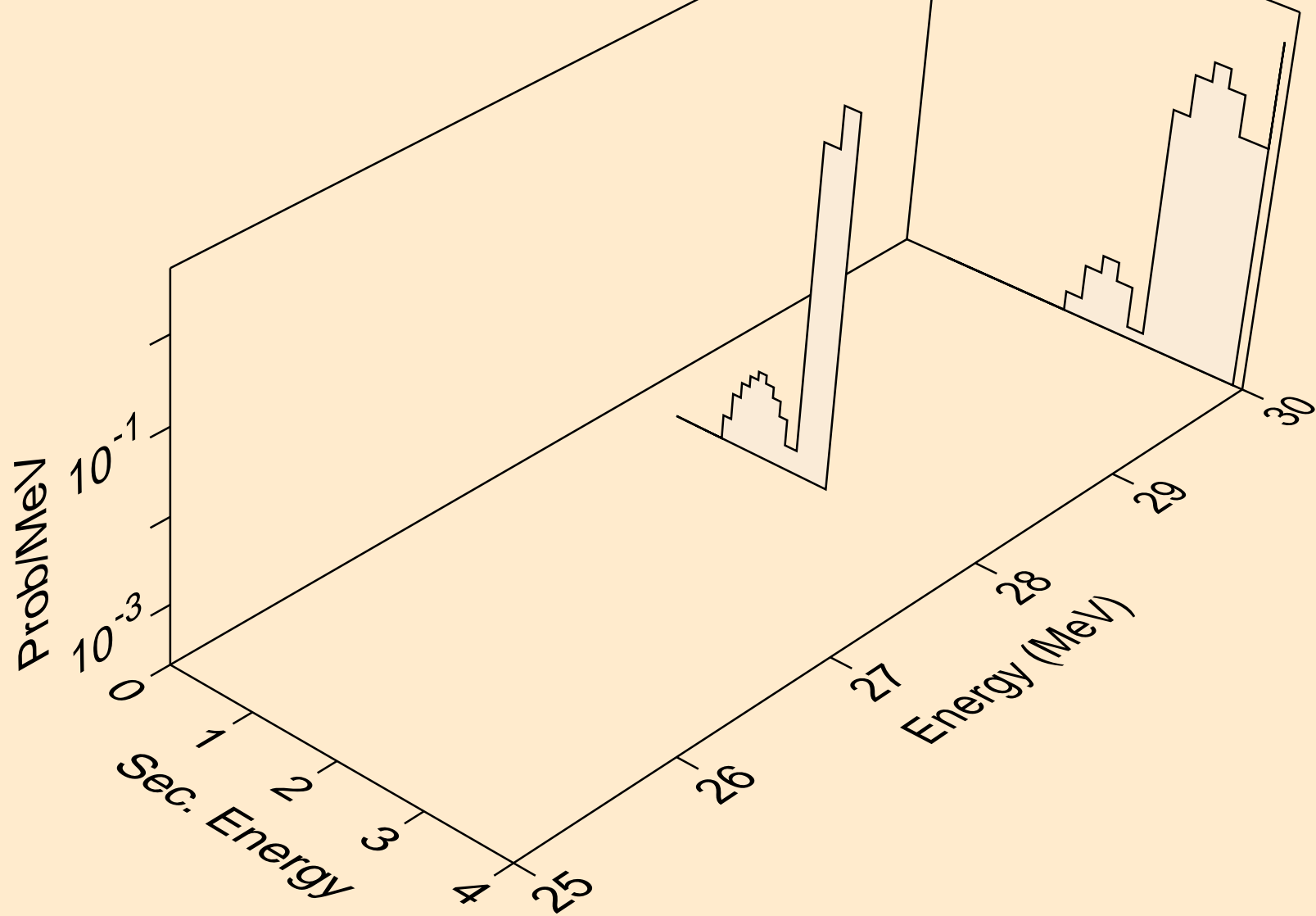

P033 PHOTON ACER TENDL-2024 LIBRARY; T=0.K
alphas from (g,x)

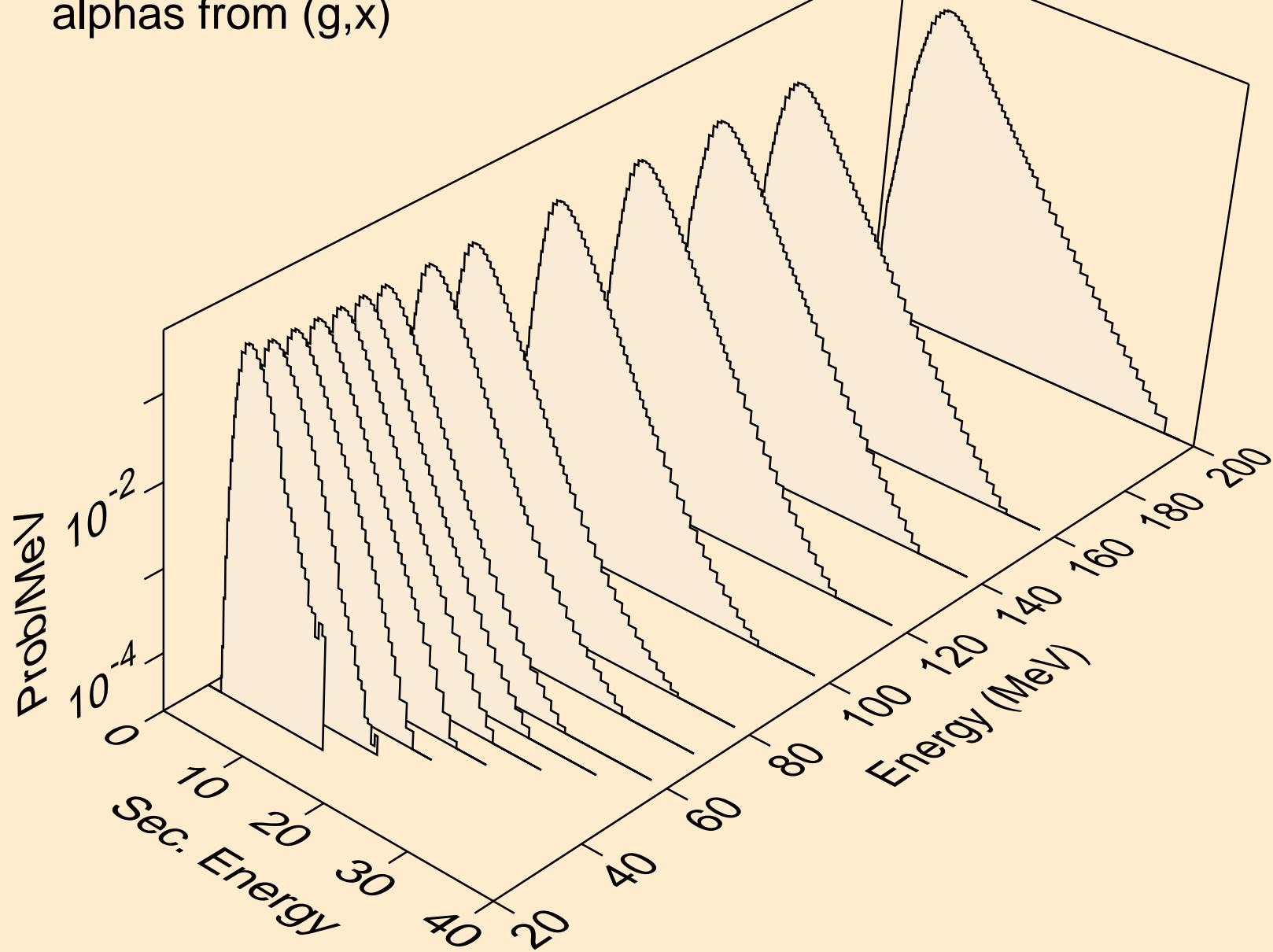

P033 PHOTON ACER TENDL-2024 LIBRARY; T=0.K
alphas from (g,n*)a

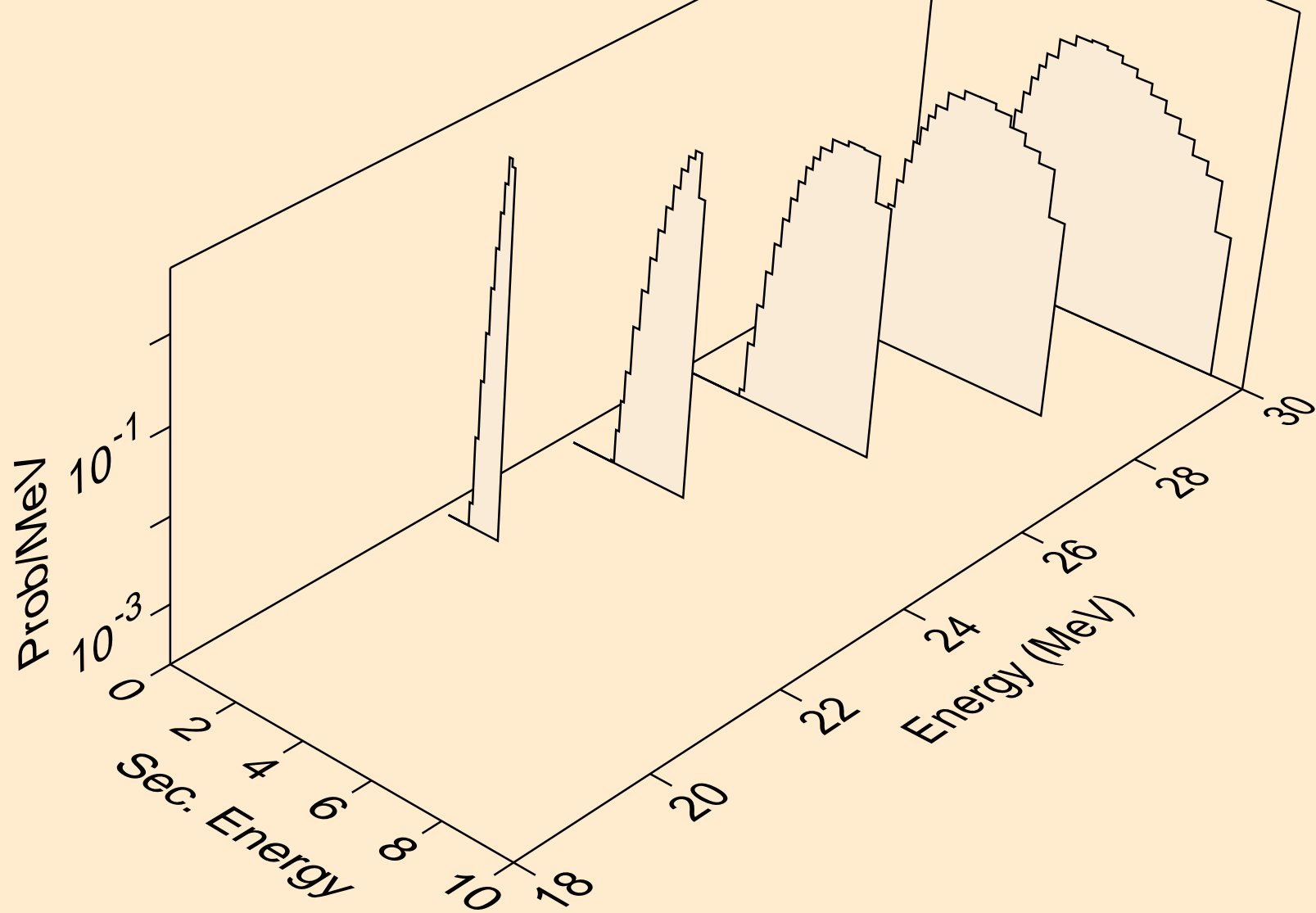

P033 PHOTON ACER TENDL-2024 LIBRARY; T=0.K
alphas from (g,a)

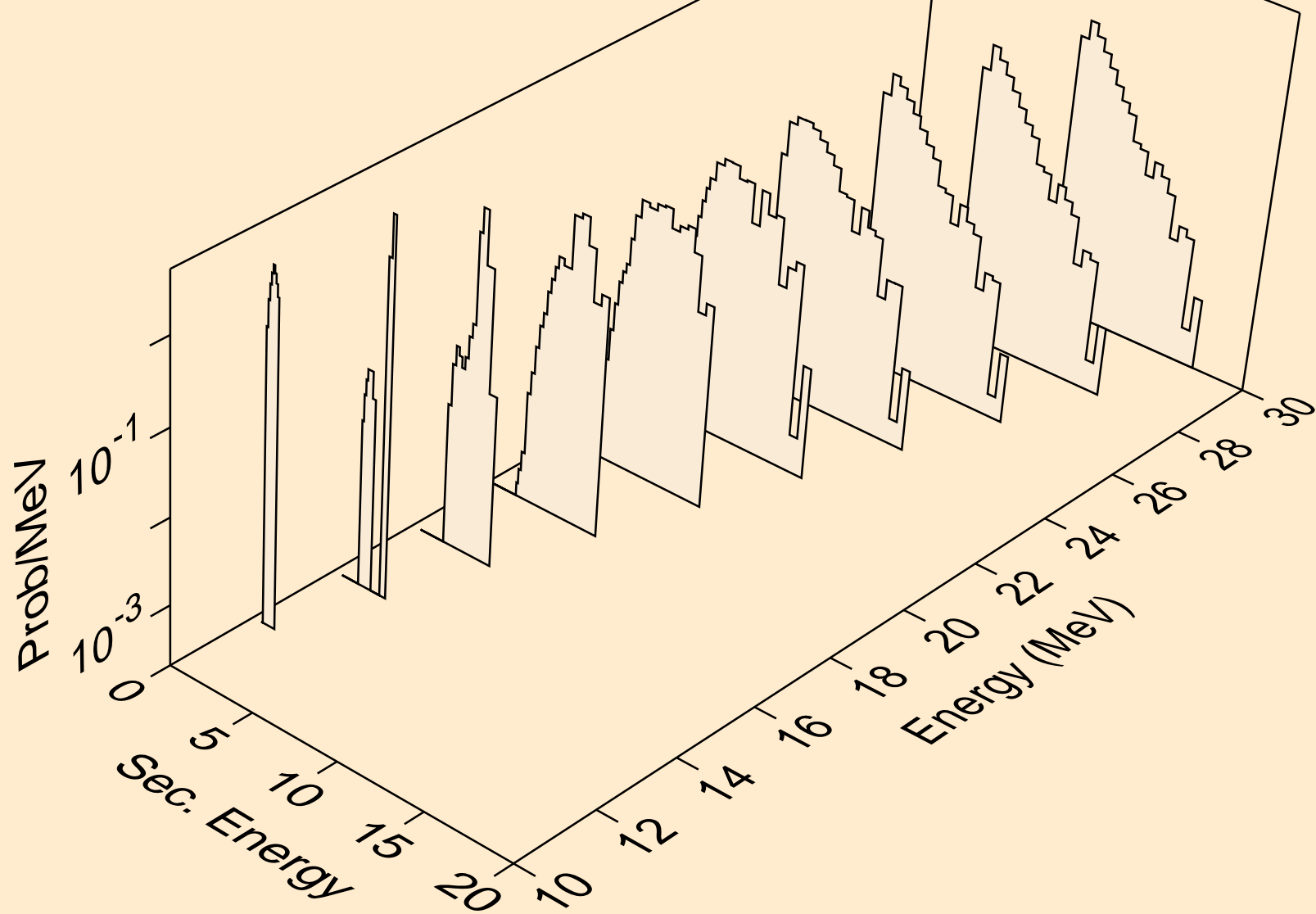

P033 PHOTON ACER TENDL-2024 LIBRARY; T=0.K
alphas from (g,2a)

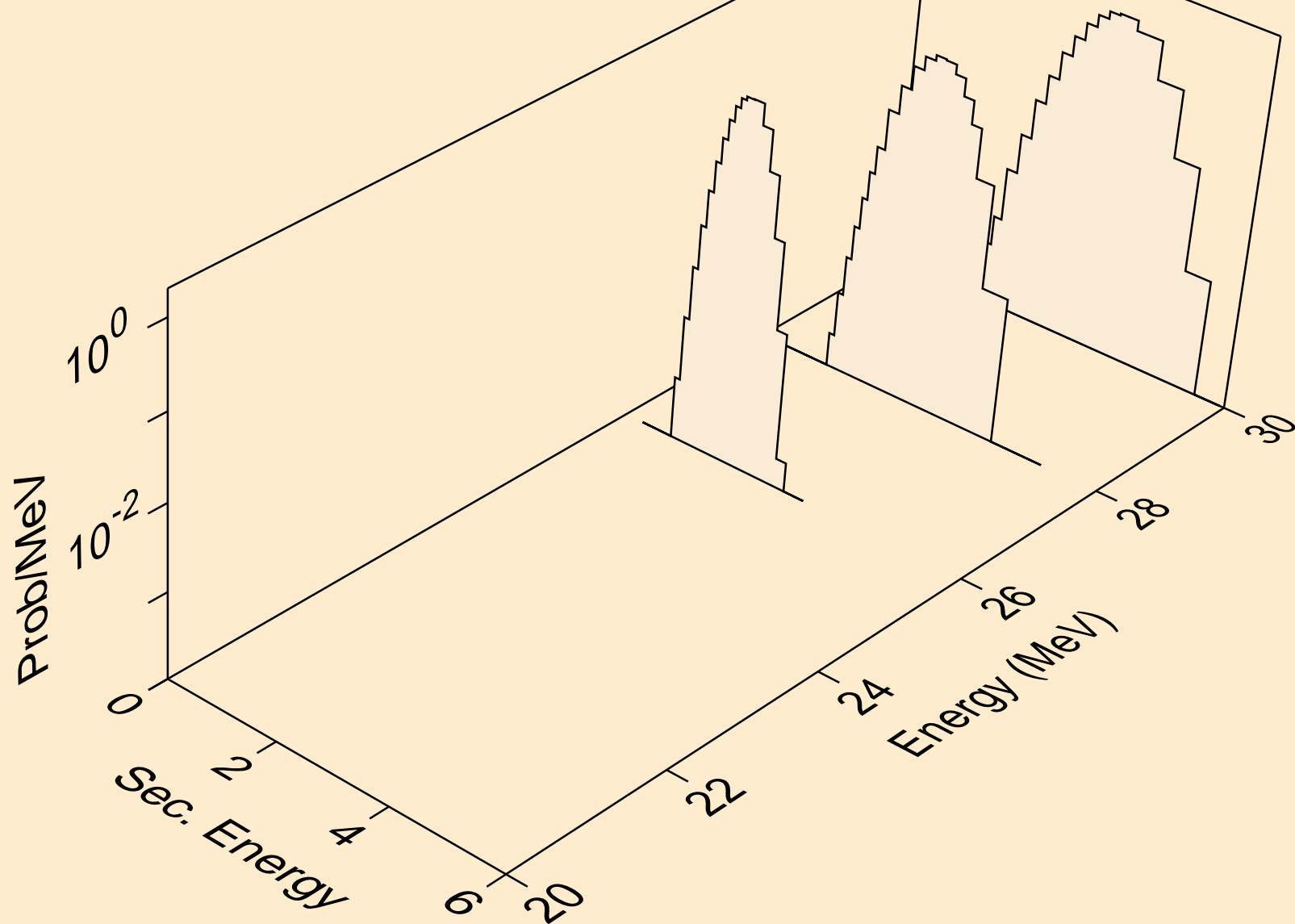

P033 PHOTON ACER TENDL-2024 LIBRARY; T=0.K
alphas from (g,pa)

