

RH094 PHOTON ACER TENDL-2024 LIBRARY; T=0.K
Principal cross sections

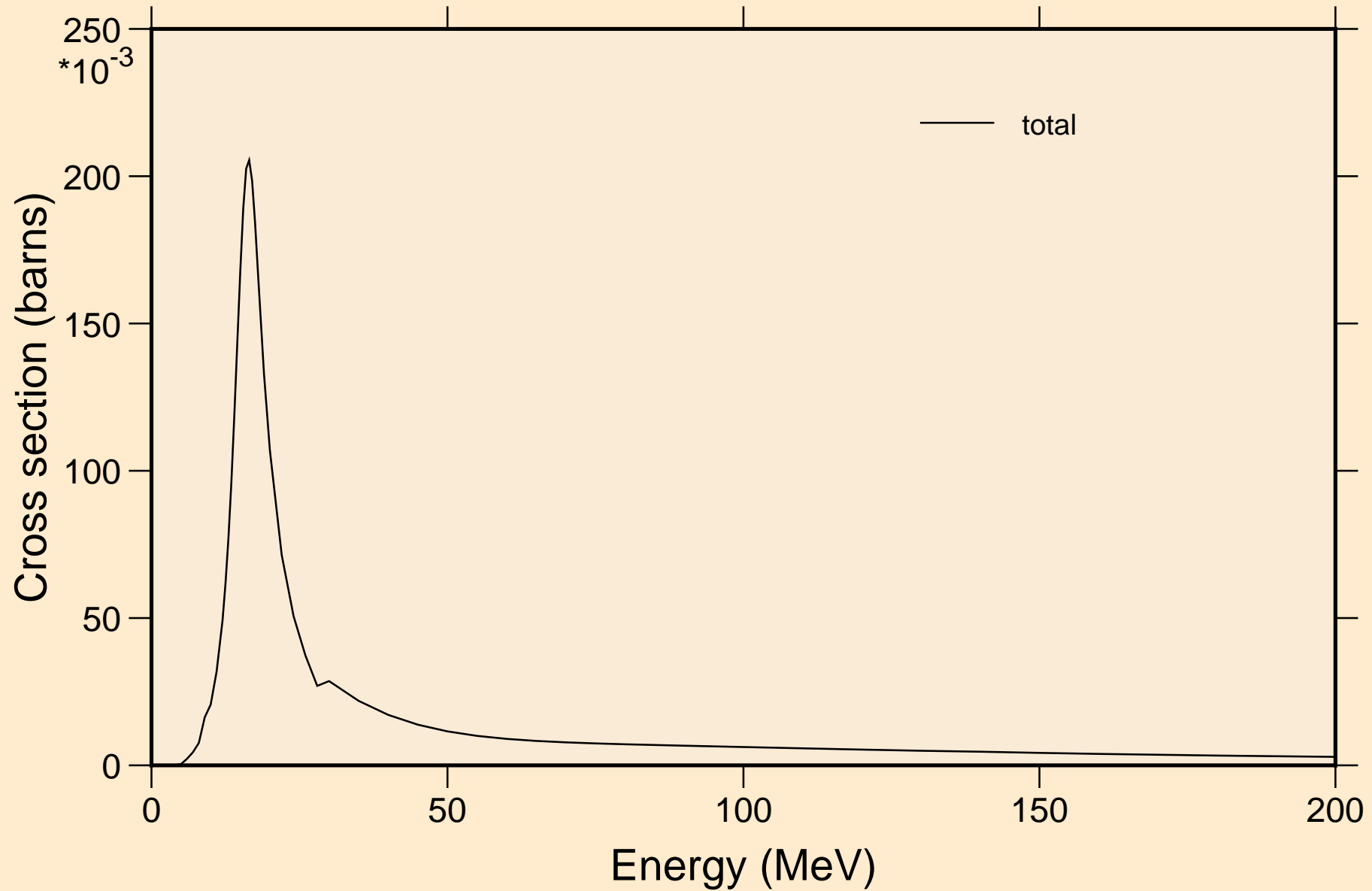

RH094 PHOTON ACER TENDL-2024 LIBRARY; T=0.K

Partial cross sections

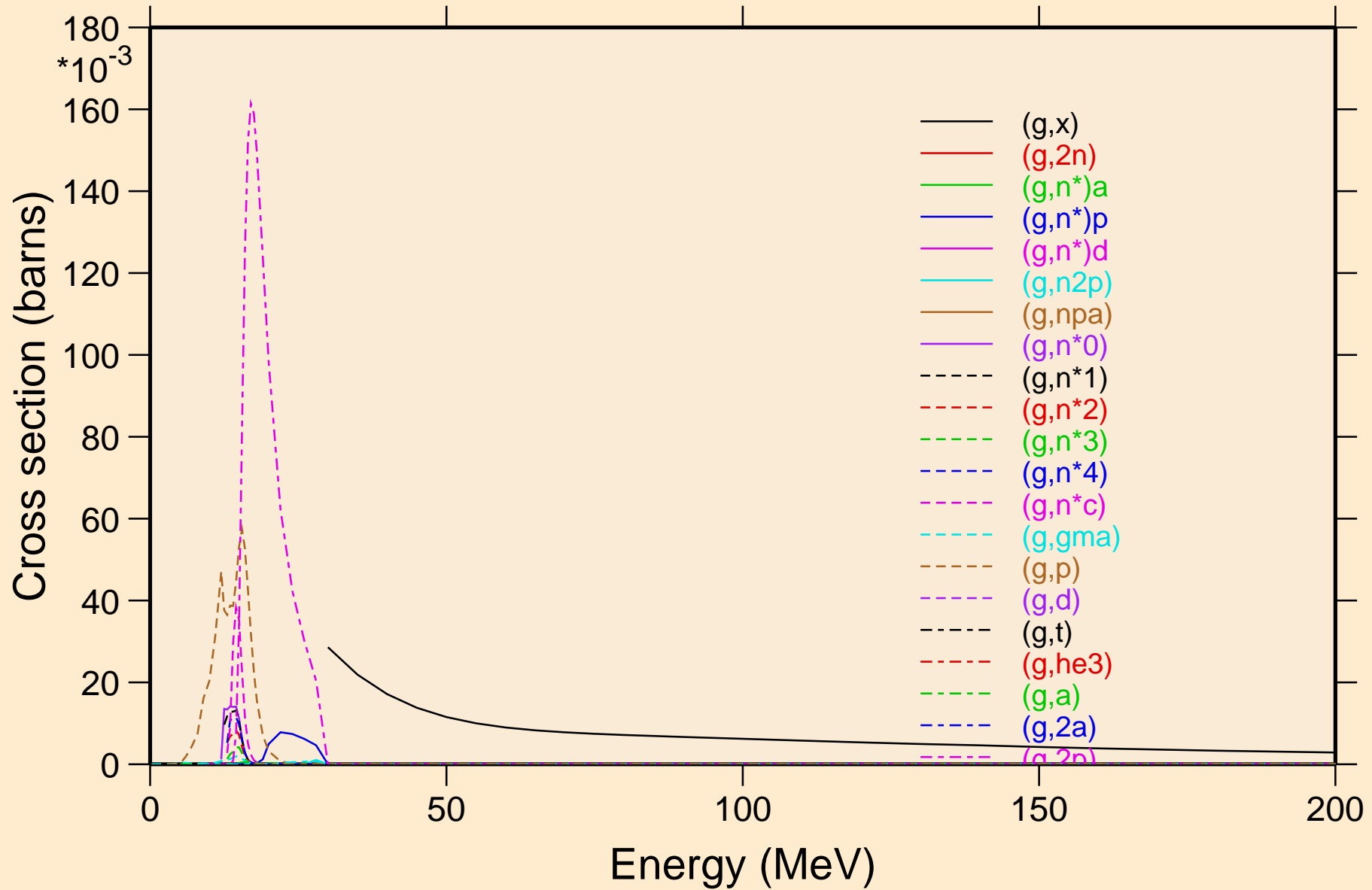

RH094 PHOTON ACER TENDL-2024 LIBRARY; T=0.K

Heating

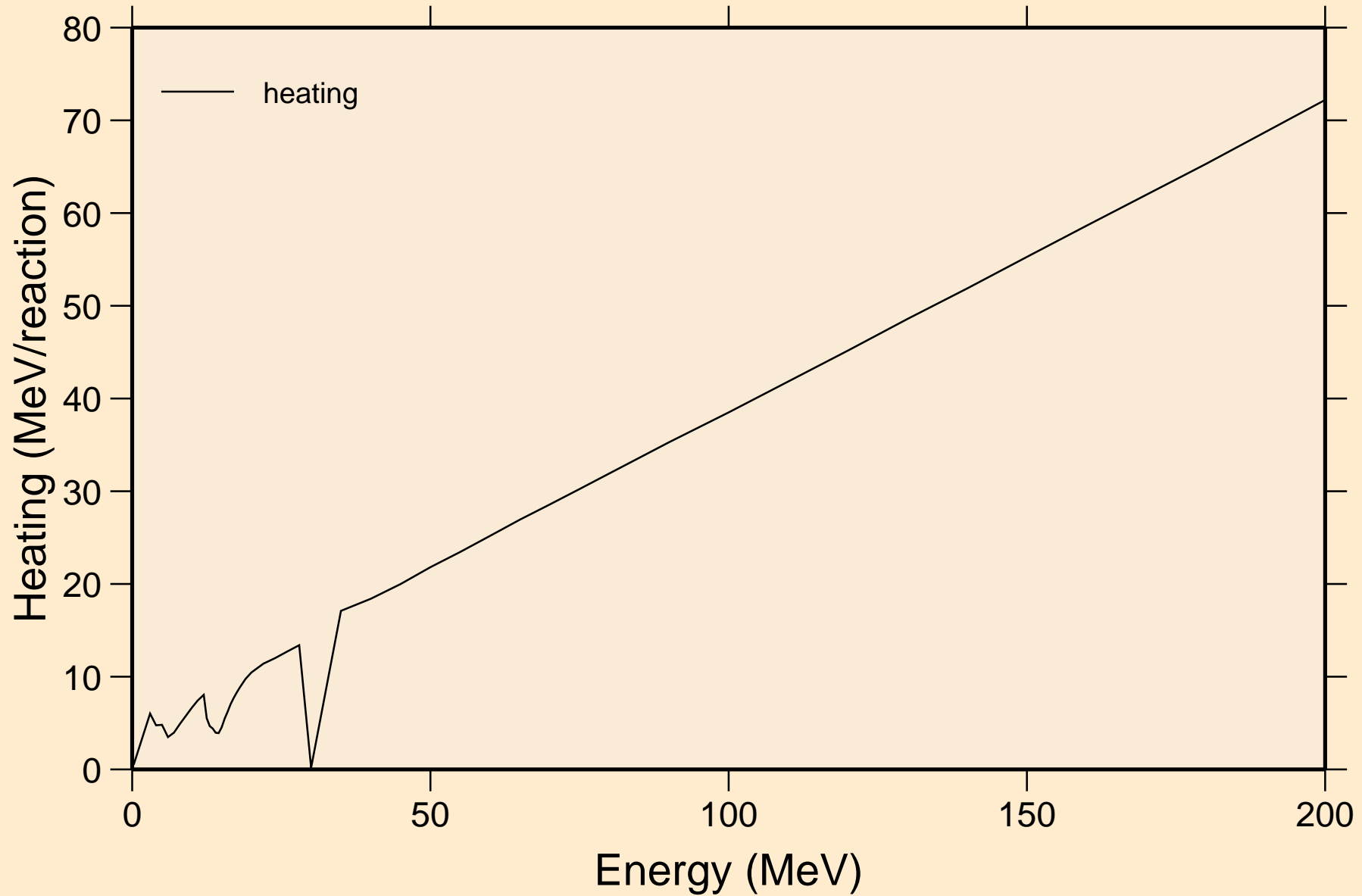

RH094 PHOTON ACER TENDL-2024 LIBRARY; T=0.K

Particle heating contributions

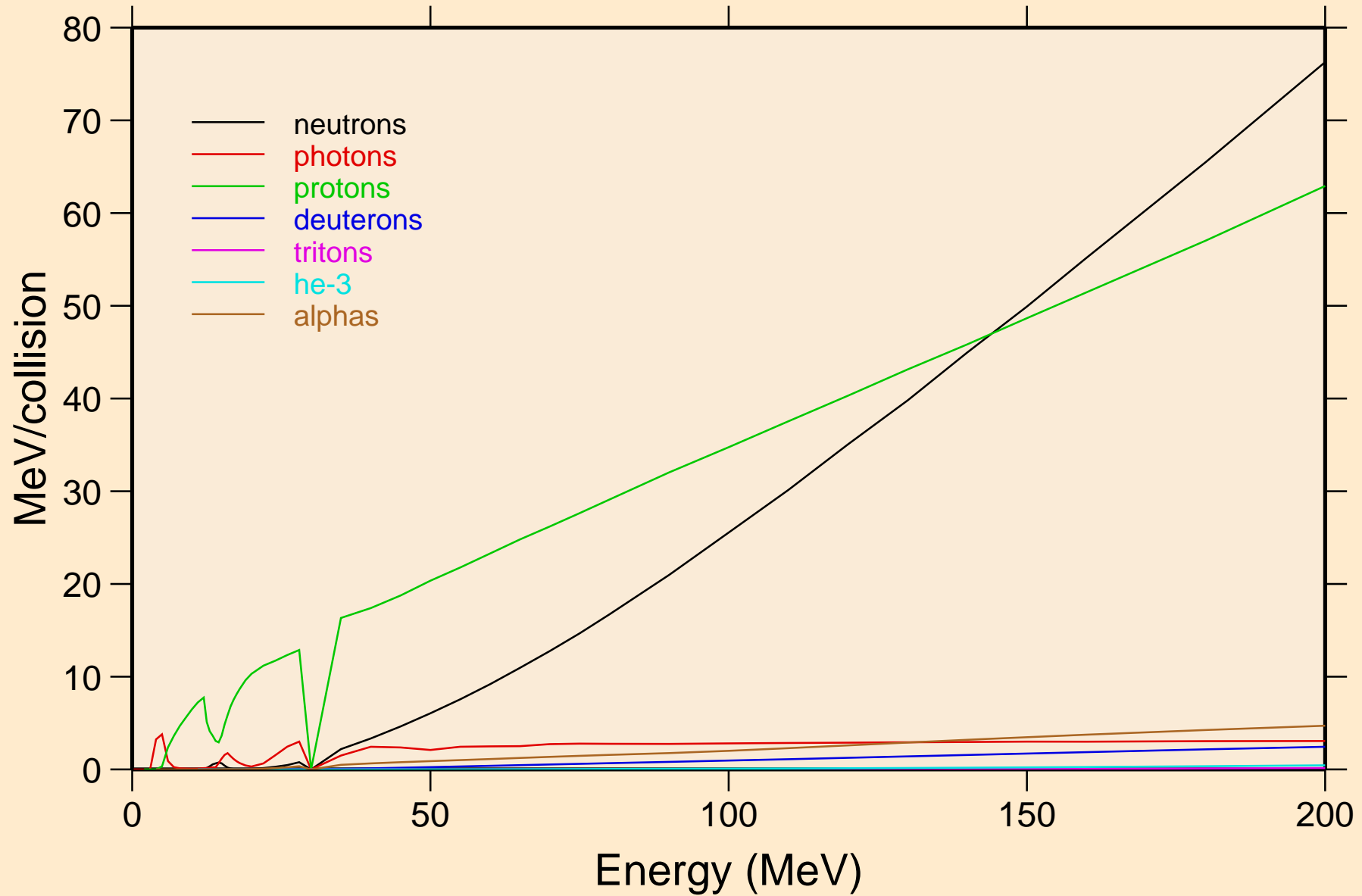

RH094 PHOTON ACER TENDL-2024 LIBRARY; T=0.K

Particle production cross sections

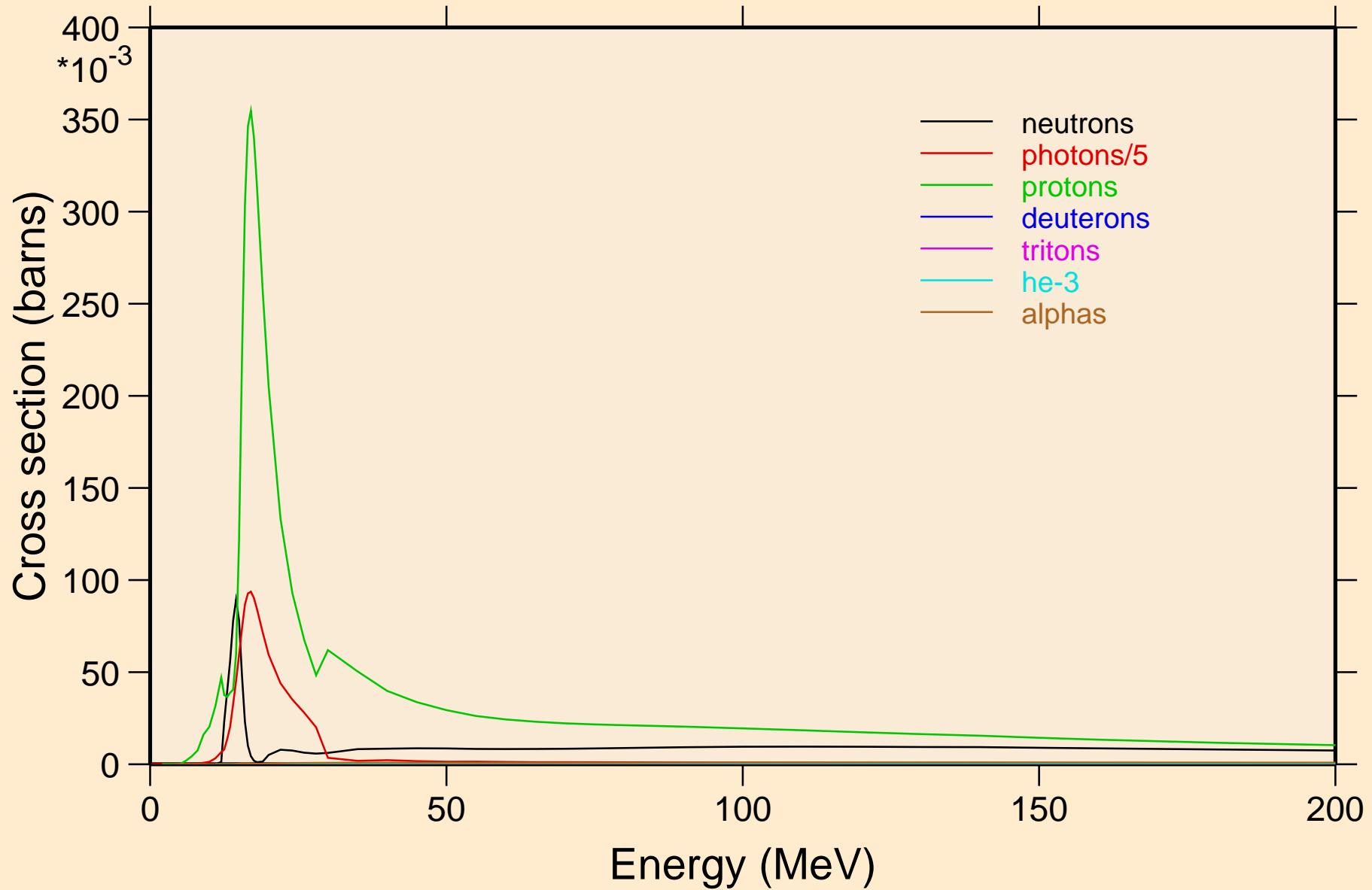

RH094 PHOTON ACER TENDL-2024 LIBRARY; T=0.K
neutrons from (g,x)

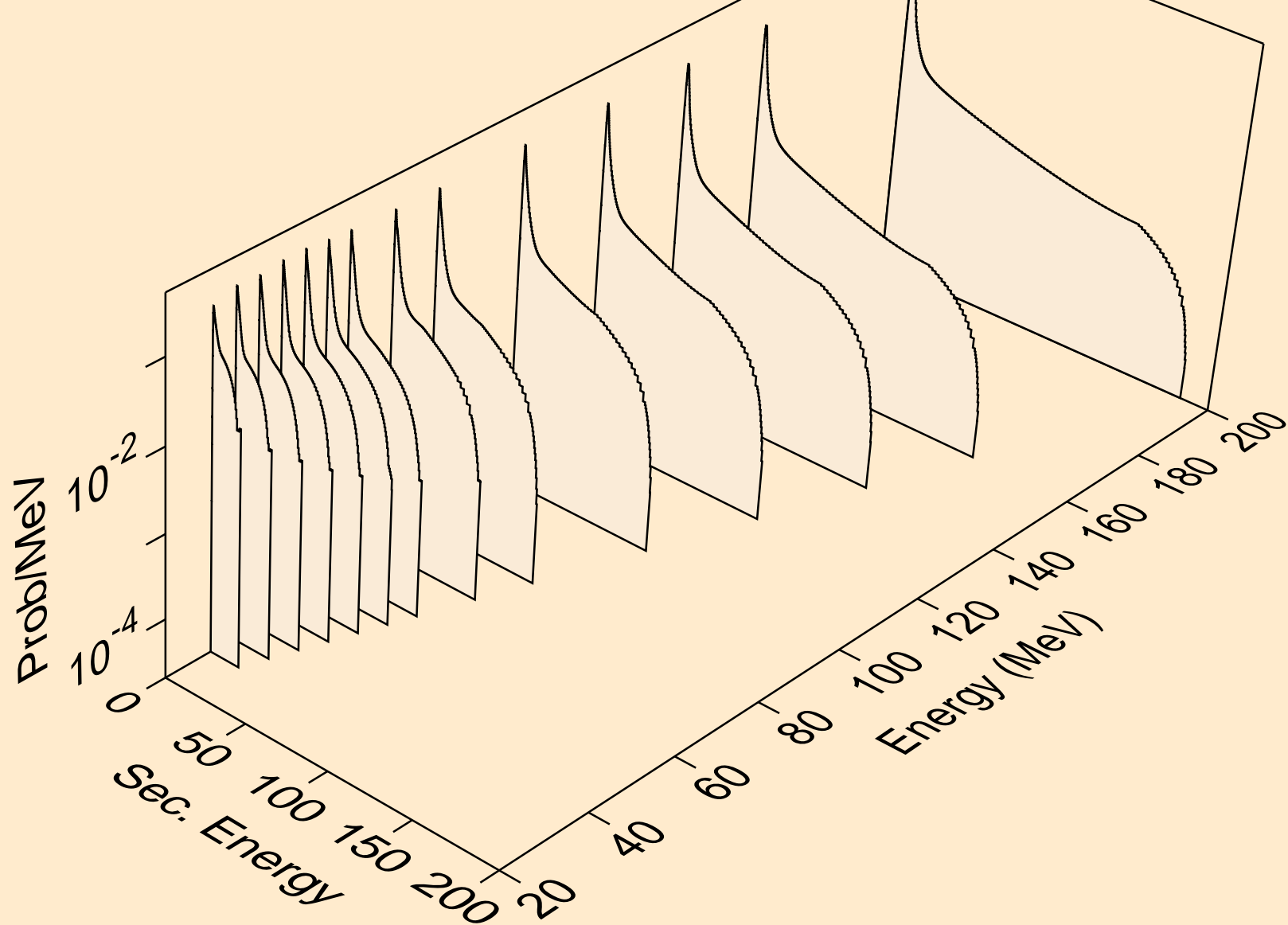

RH094 PHOTON ACER TENDL-2024 LIBRARY; T=0.K
neutrons from (g,2n)

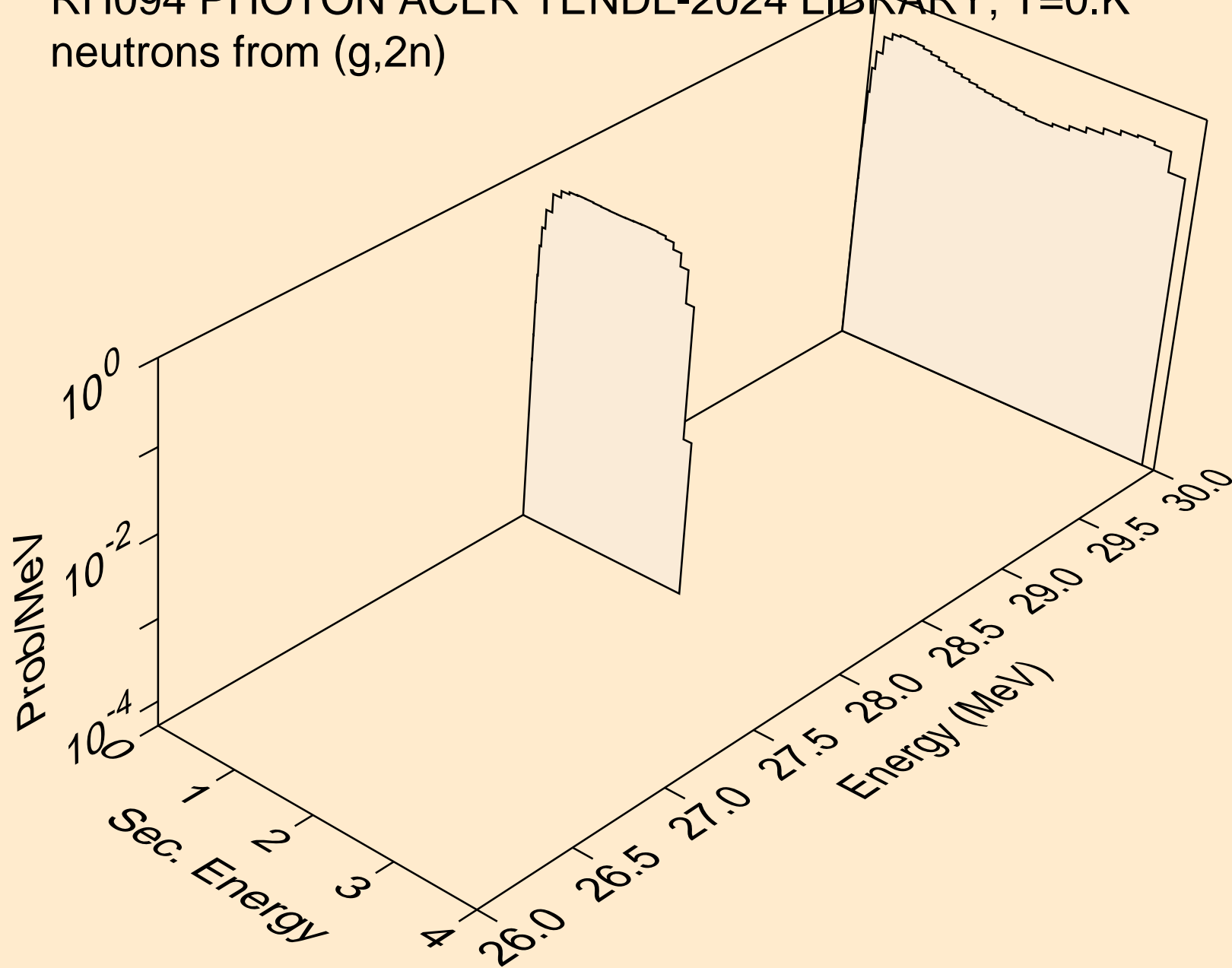

RH094 PHOTON ACER TENDL-2024 LIBRARY; T=0.K
neutrons from (g,n*)a

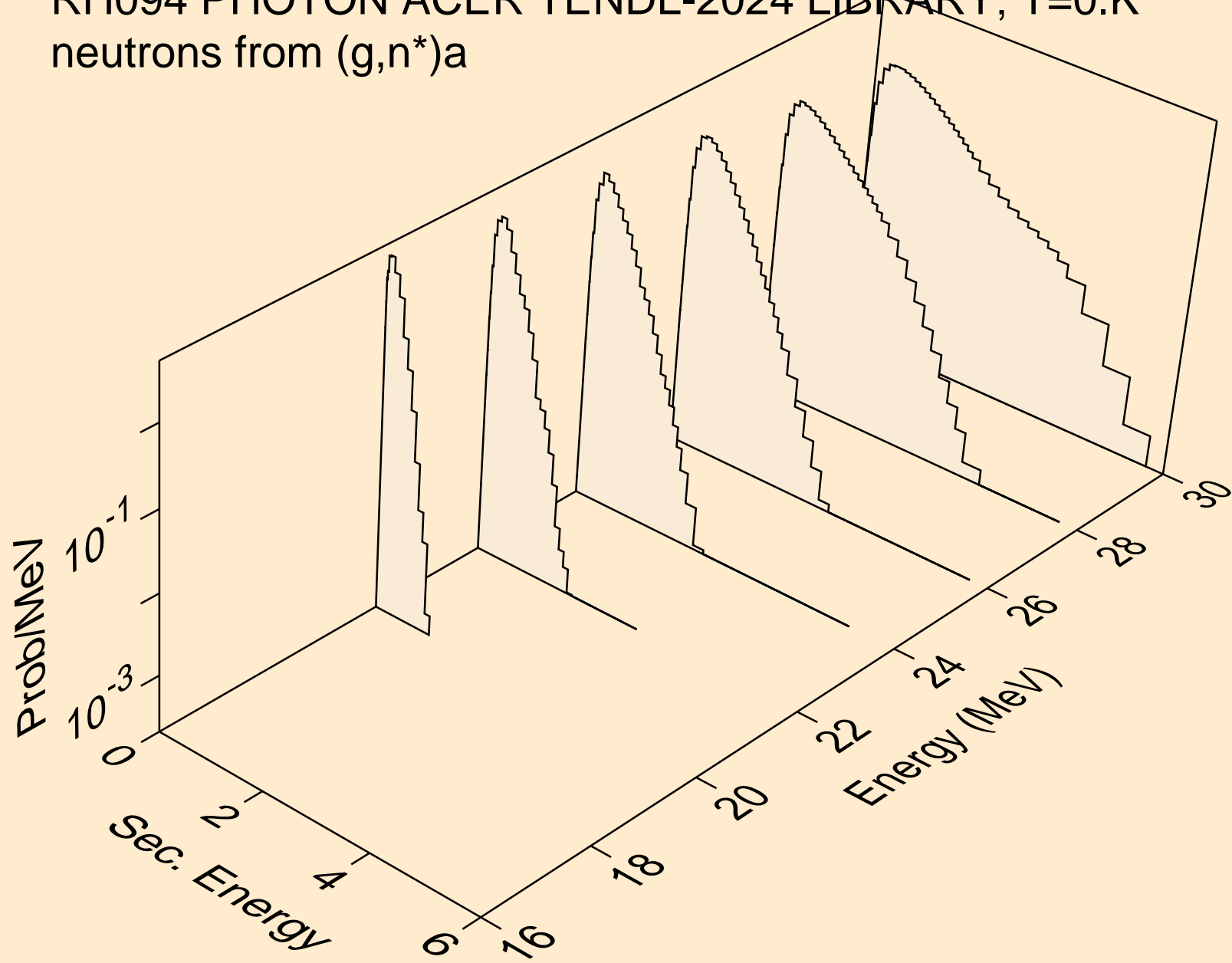

RH094 PHOTON ACER TENDL-2024 LIBRARY; T=0.K
neutrons from (g,n*)p

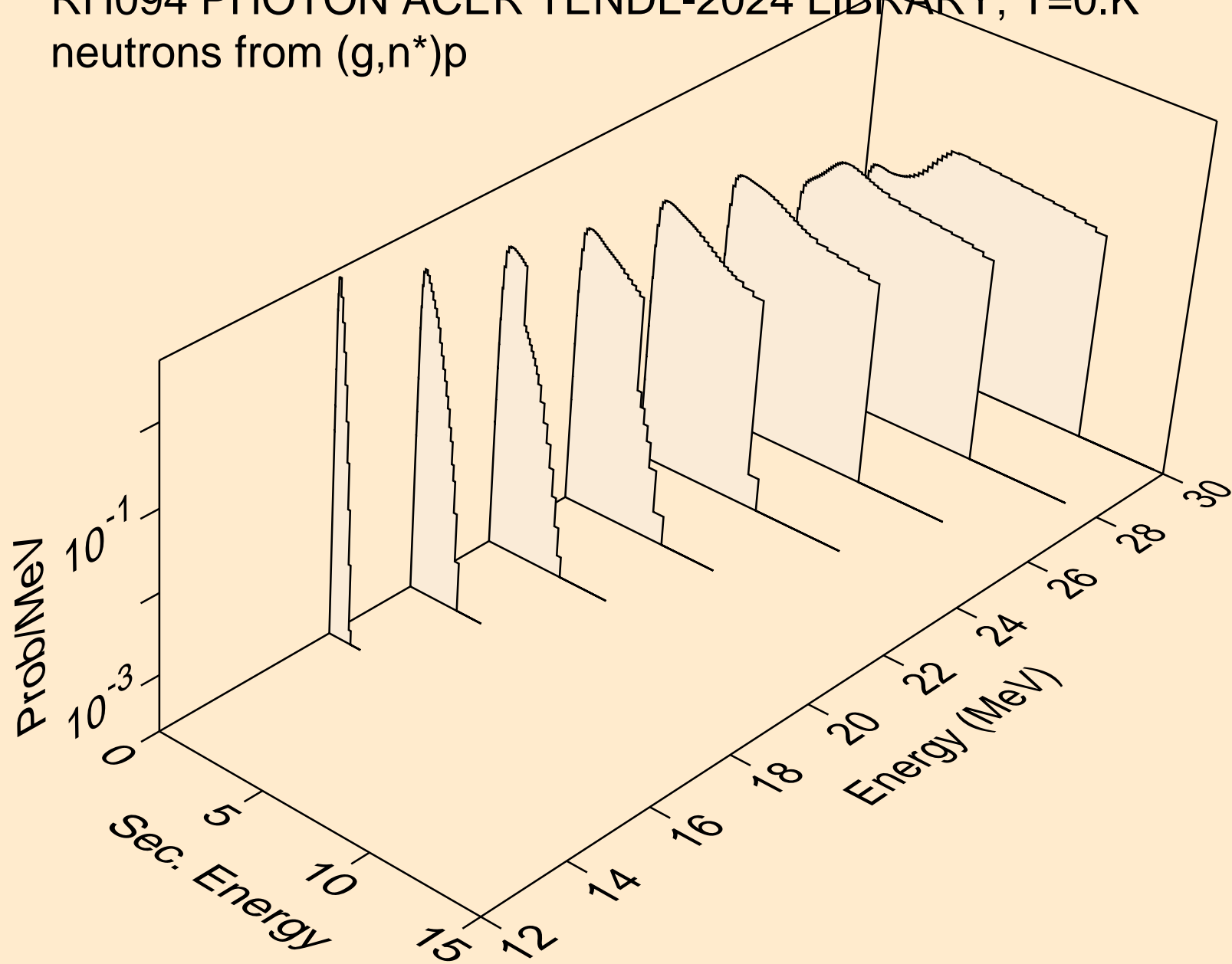

RH094 PHOTON ACER TENDL-2024 LIBRARY; T=0.K
neutrons from (g,n*)d

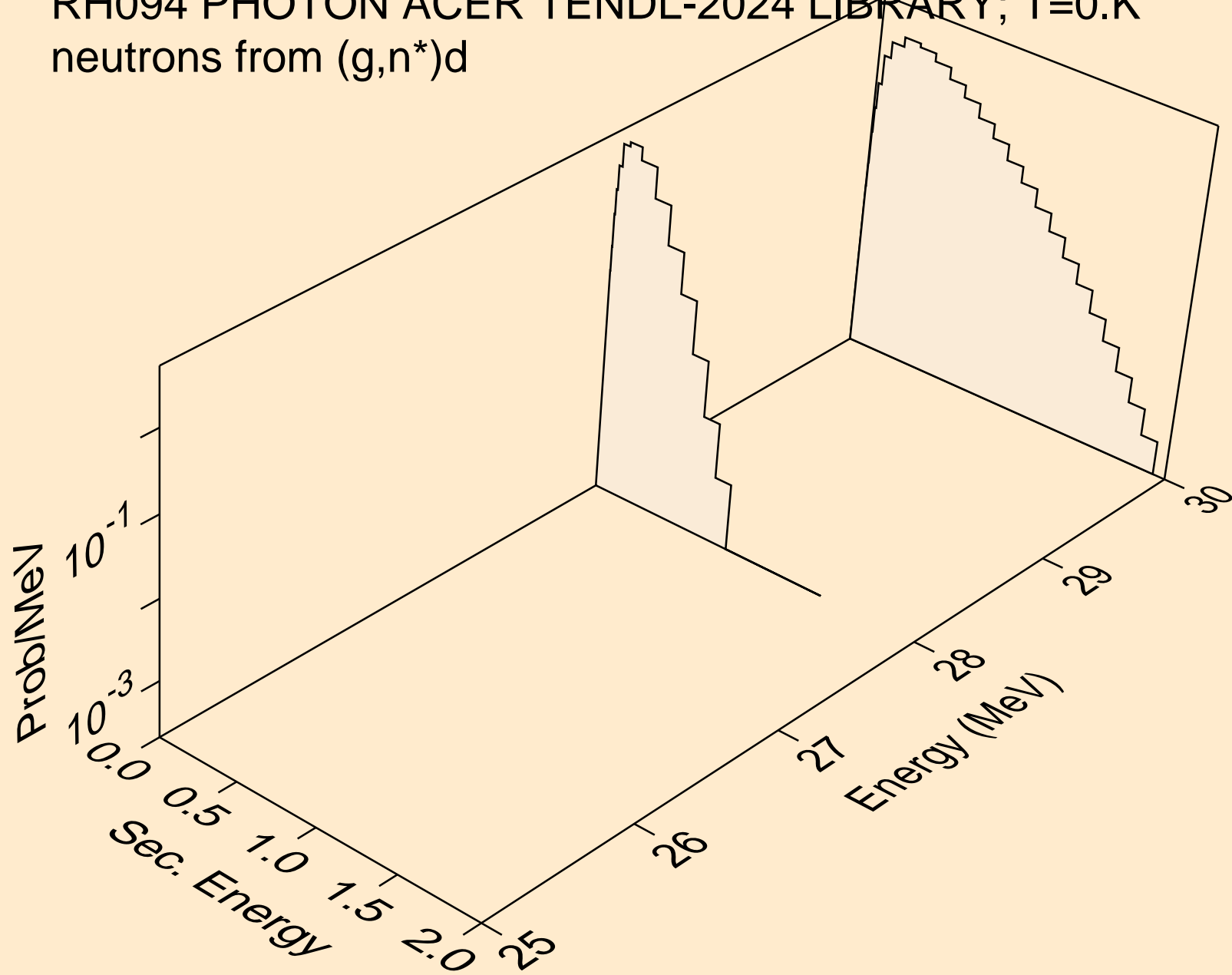

RH094 PHOTON ACER TENDL-2024 LIBRARY; T=0.K
neutrons from (g,n2p)

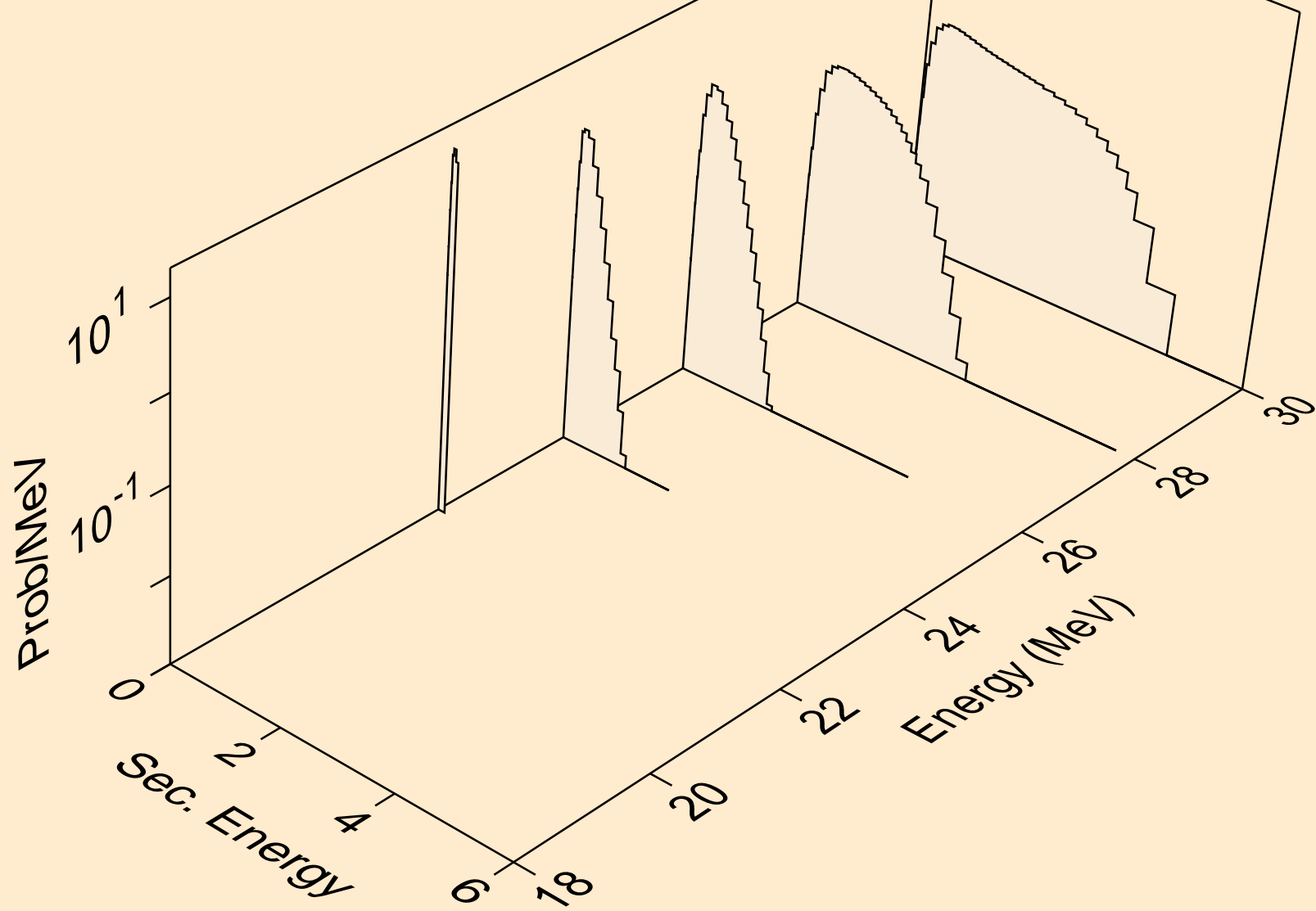

RH094 PHOTON ACER TENDL-2024 LIBRARY; T=0.K
neutrons from (g,npa)

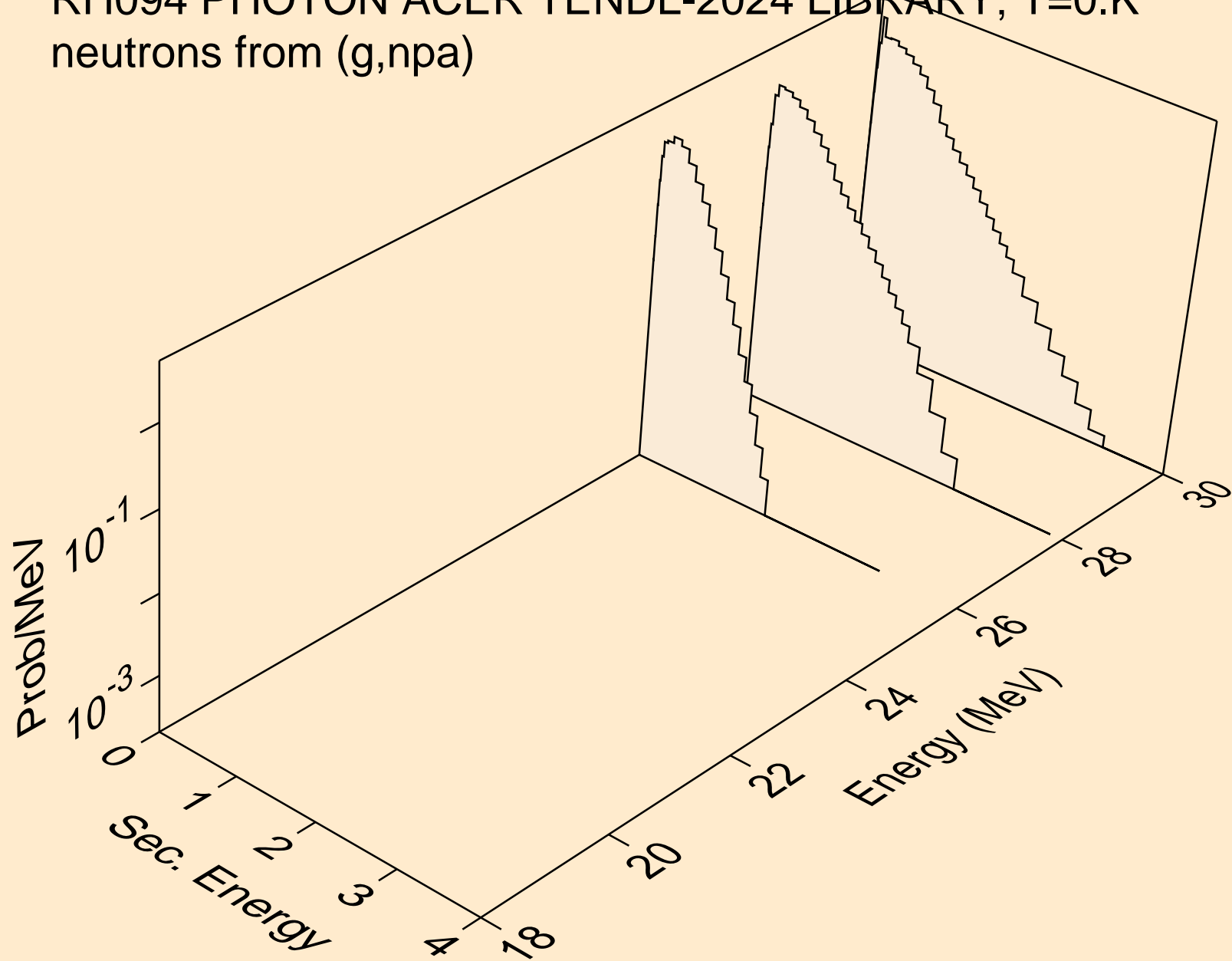

RH094 PHOTON ACER TENDL-2024 LIBRARY; T=0.K
angular distribution for (g,n*0) neutron

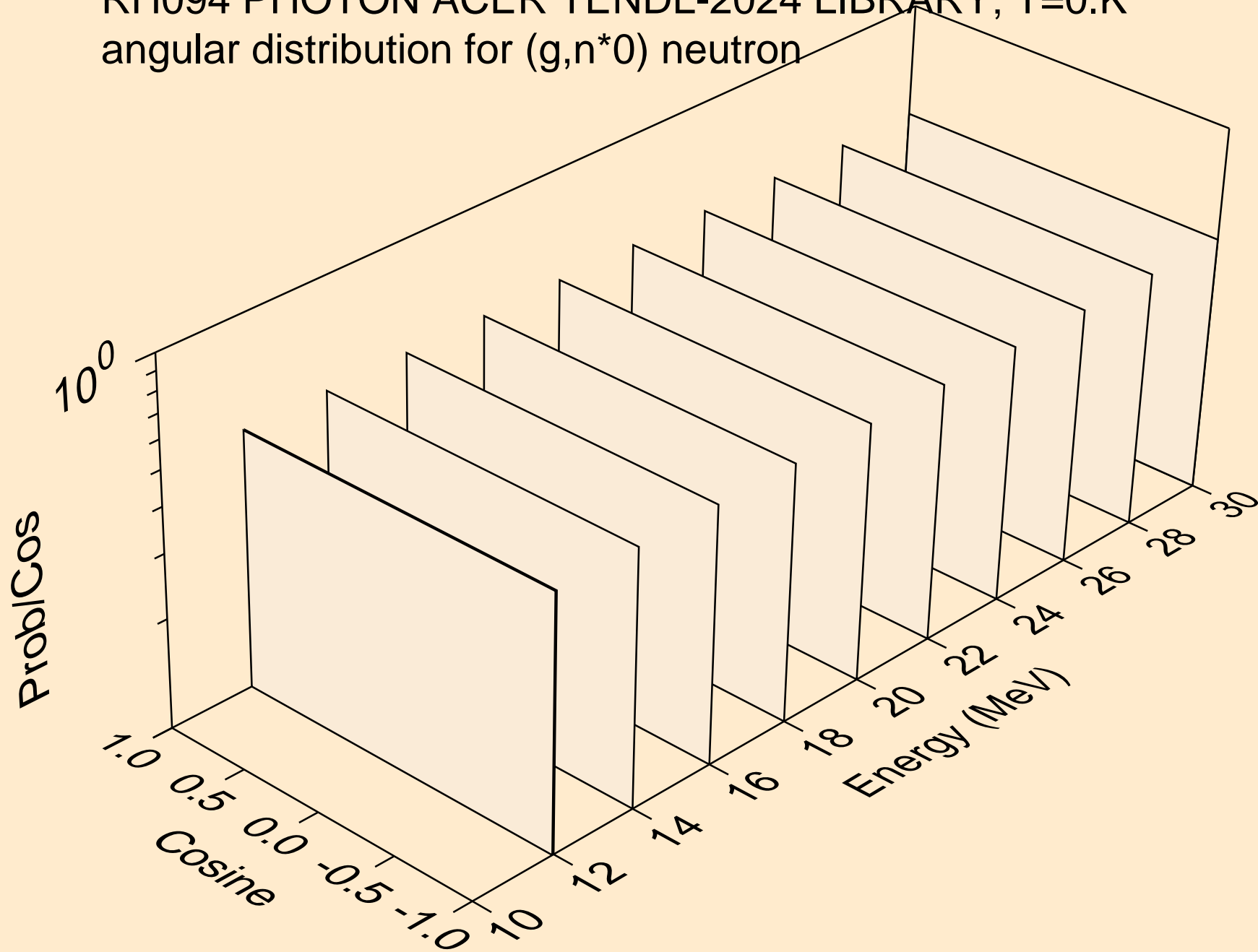

RH094 PHOTON ACER TENDL-2024 LIBRARY; T=0.K
angular distribution for (g,n*1) neutron

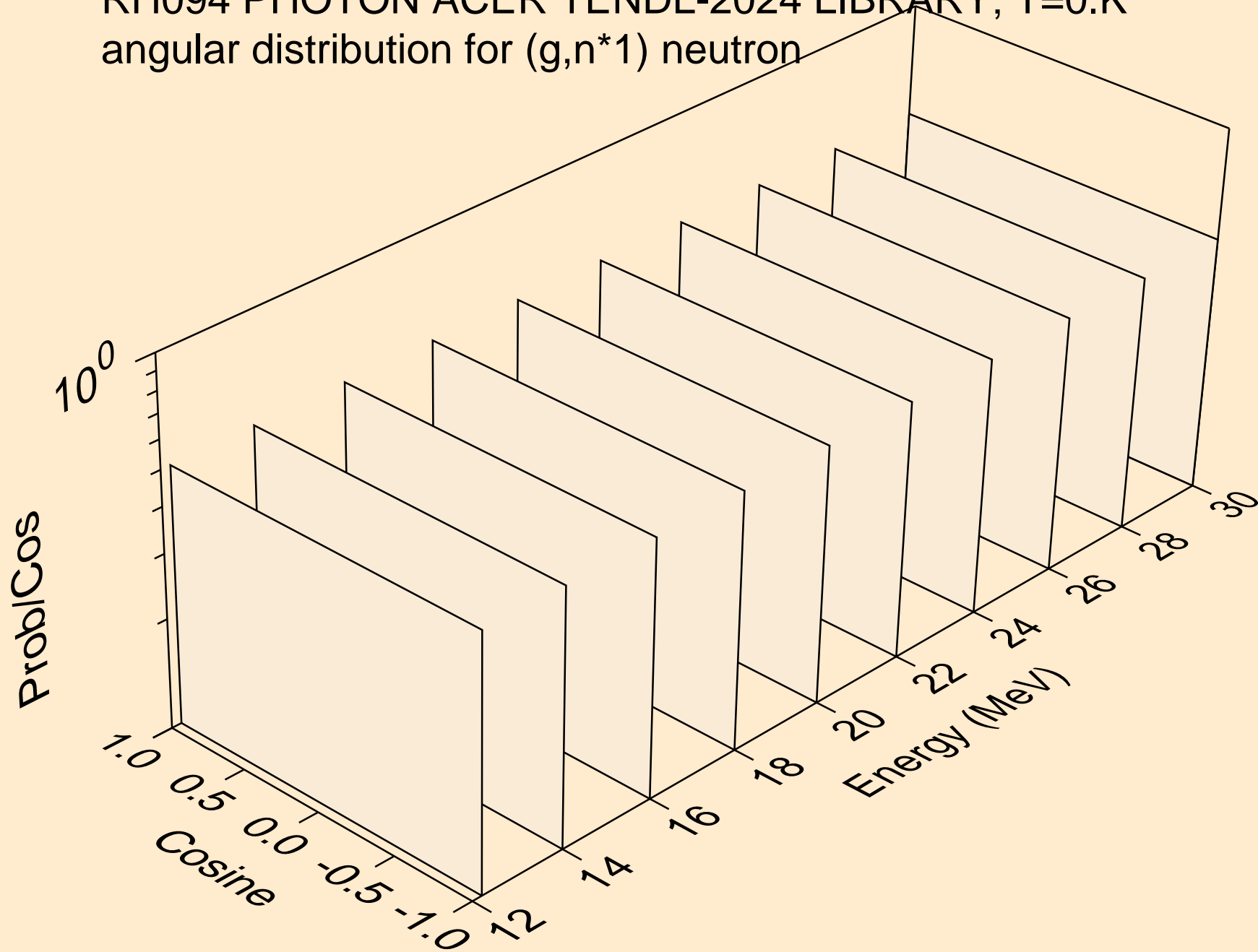

RH094 PHOTON ACER TENDL-2024 LIBRARY; T=0.K
angular distribution for (g,n*2) neutron

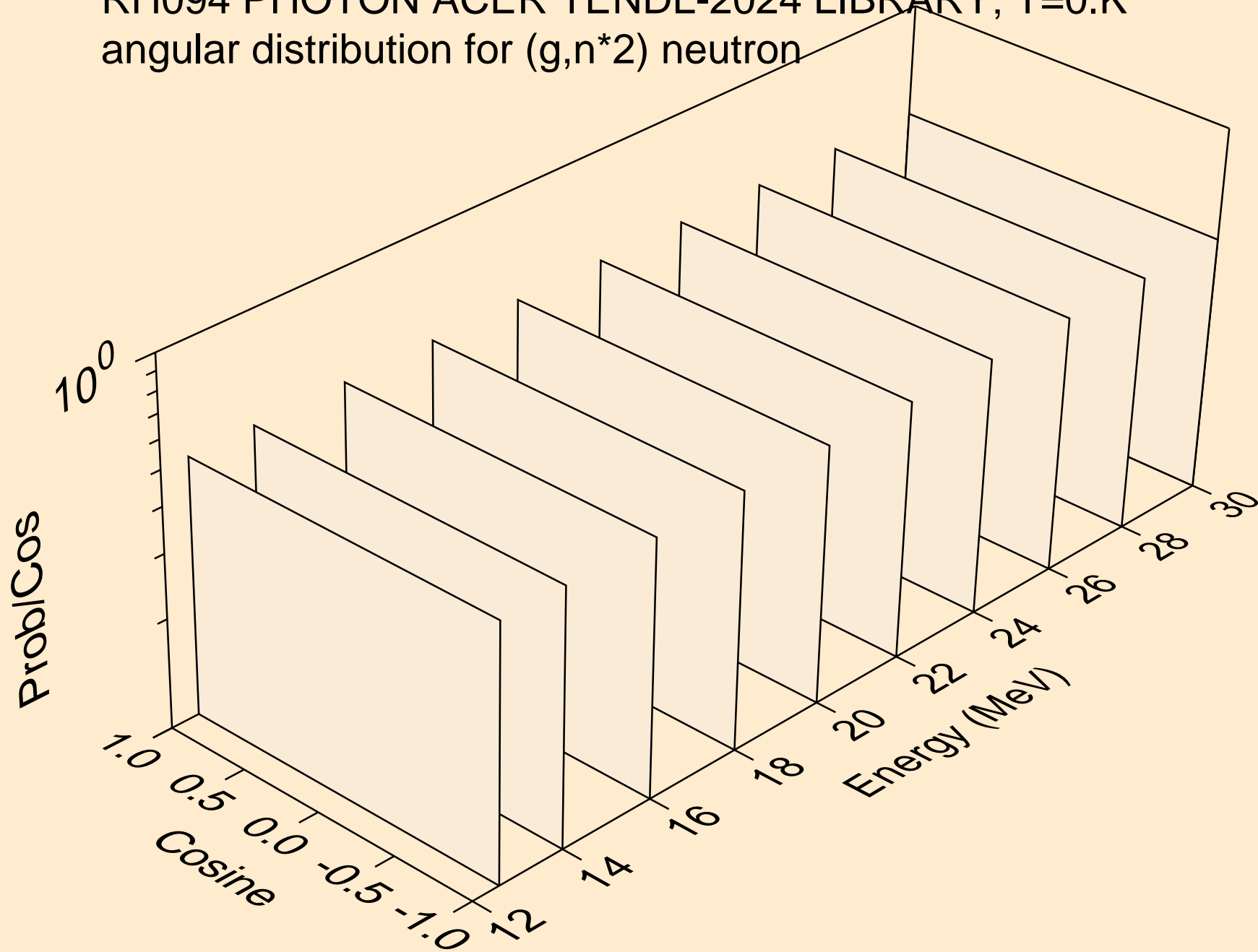

RH094 PHOTON ACER TENDL-2024 LIBRARY; T=0.K
angular distribution for (g,n*3) neutron

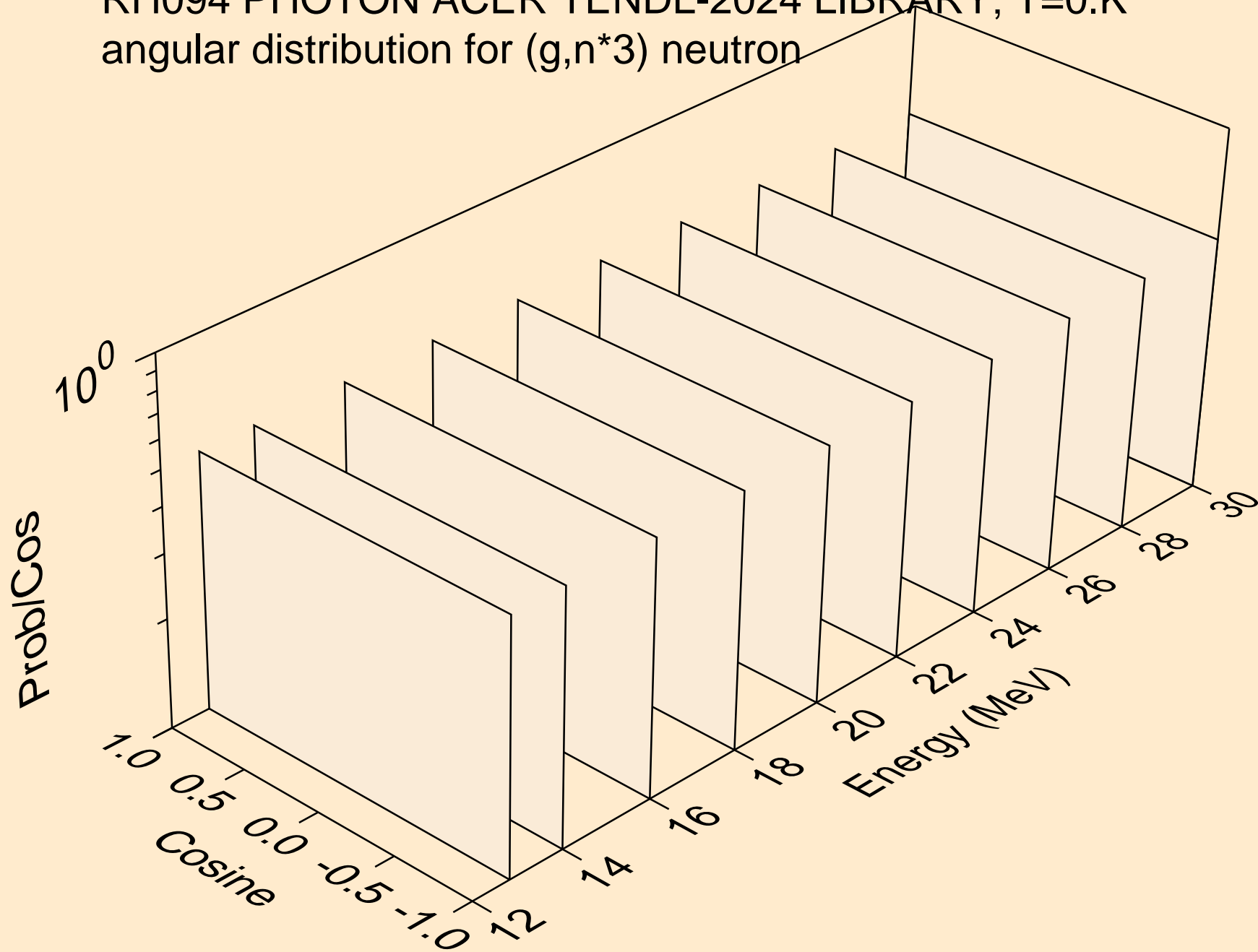

RH094 PHOTON ACER TENDL-2024 LIBRARY; T=0.K
angular distribution for (g,n*4) neutron

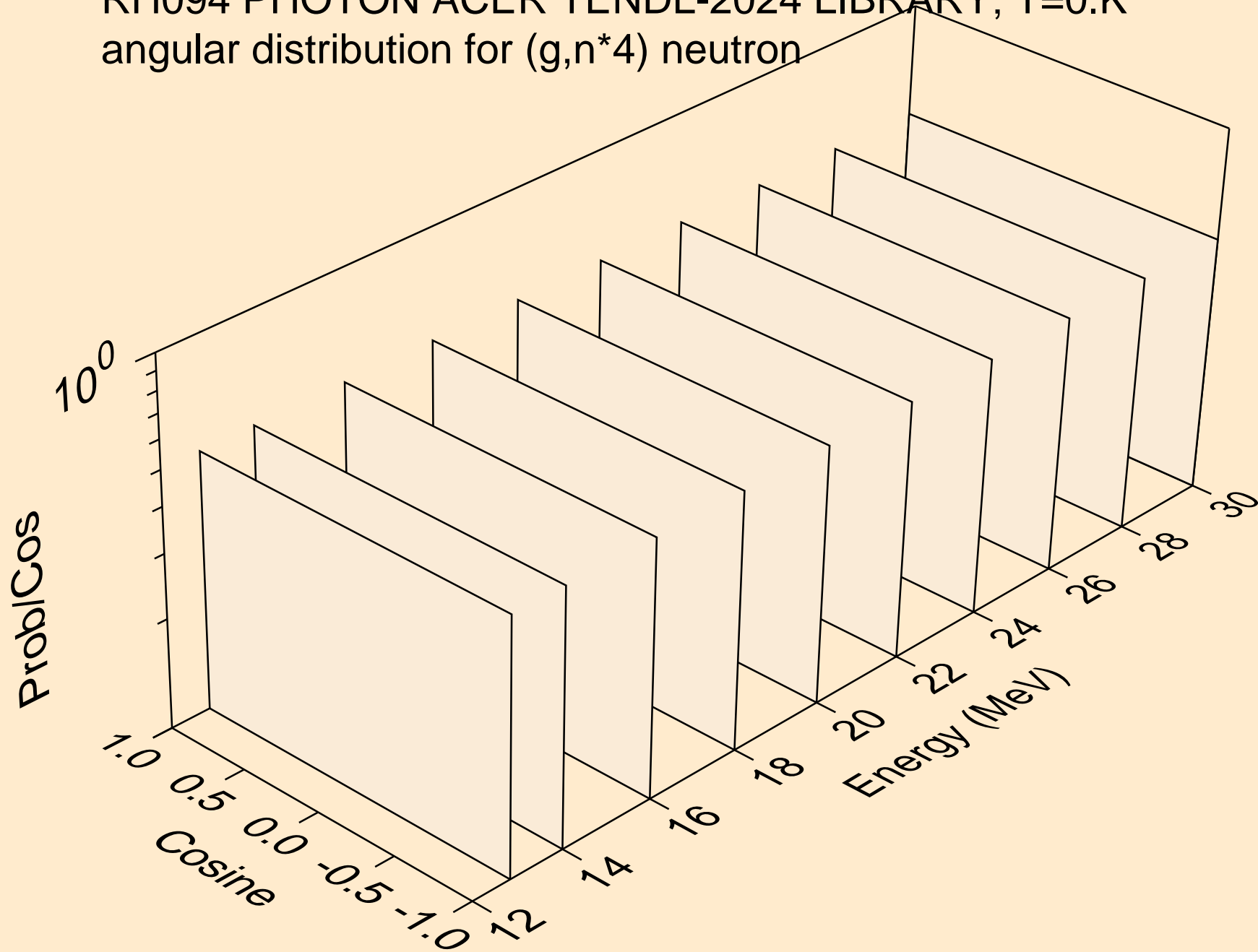

RH094 PHOTON ACER TENDL-2024 LIBRARY; T=0.K
neutrons from (g,n*c)

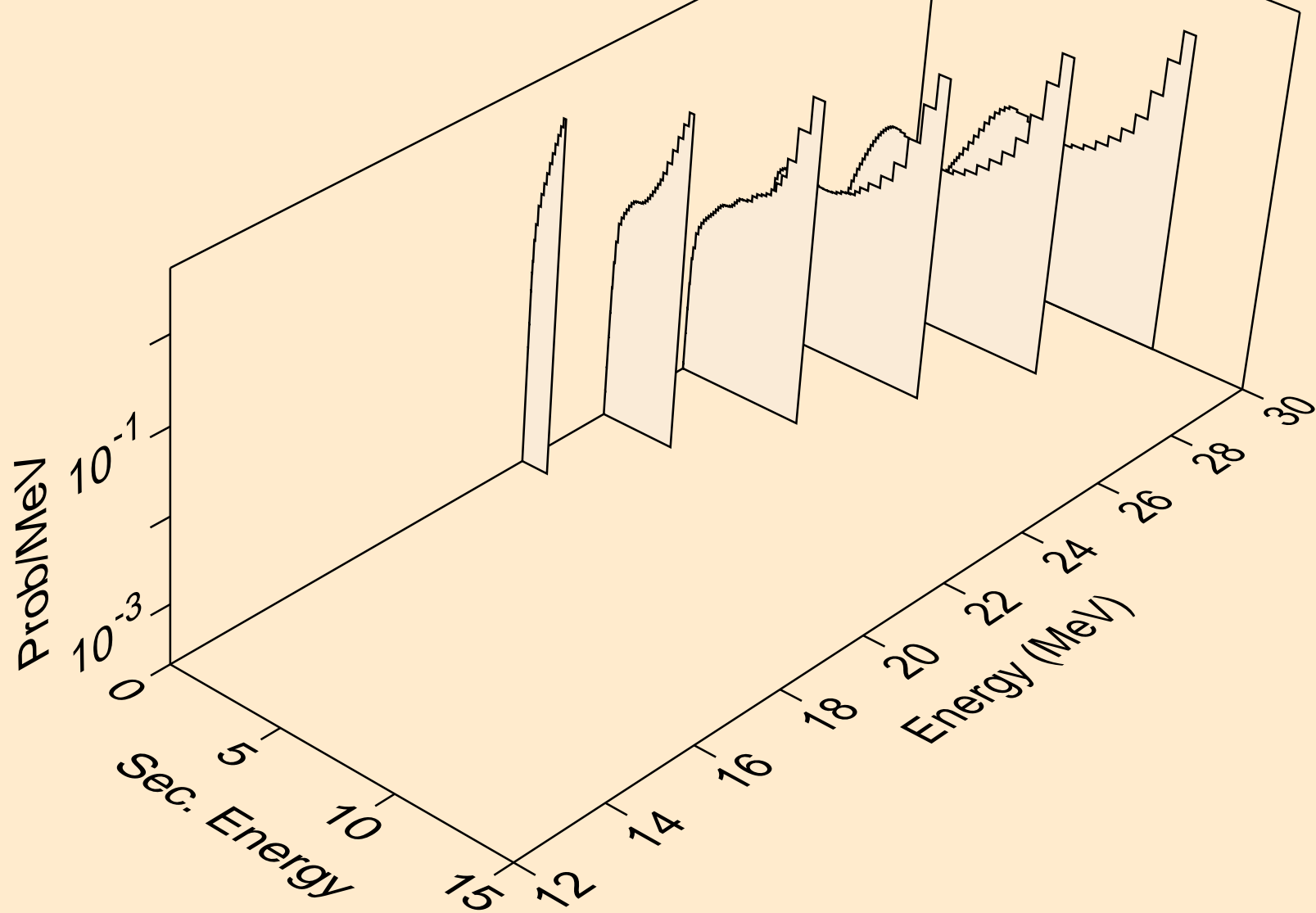

RH094 PHOTON ACER TENDL-2024 LIBRARY; T=0.K
photons from (g,x)

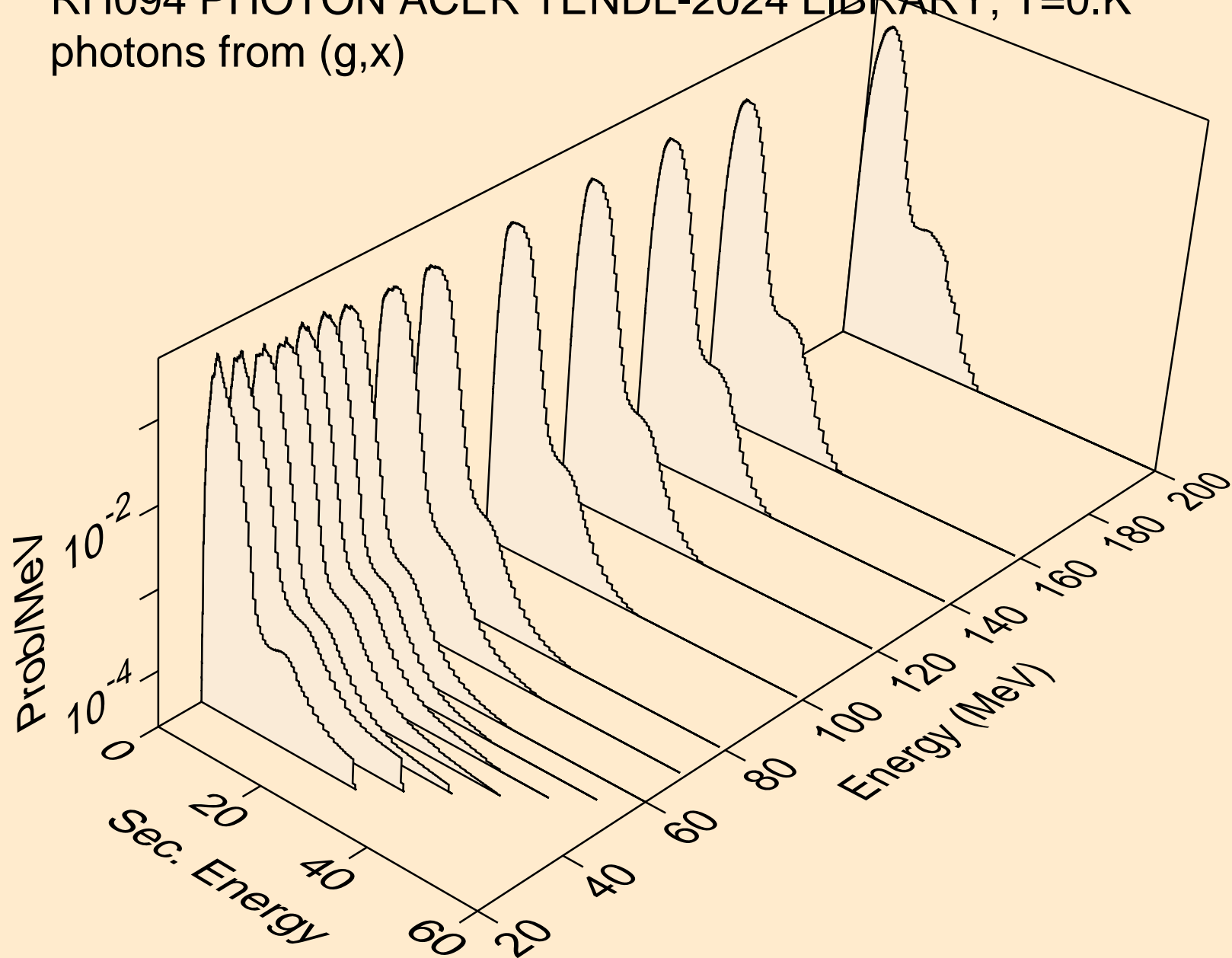

RH094 PHOTON ACER TENDL-2024 LIBRARY; T=0.K
photons from (g,2n)

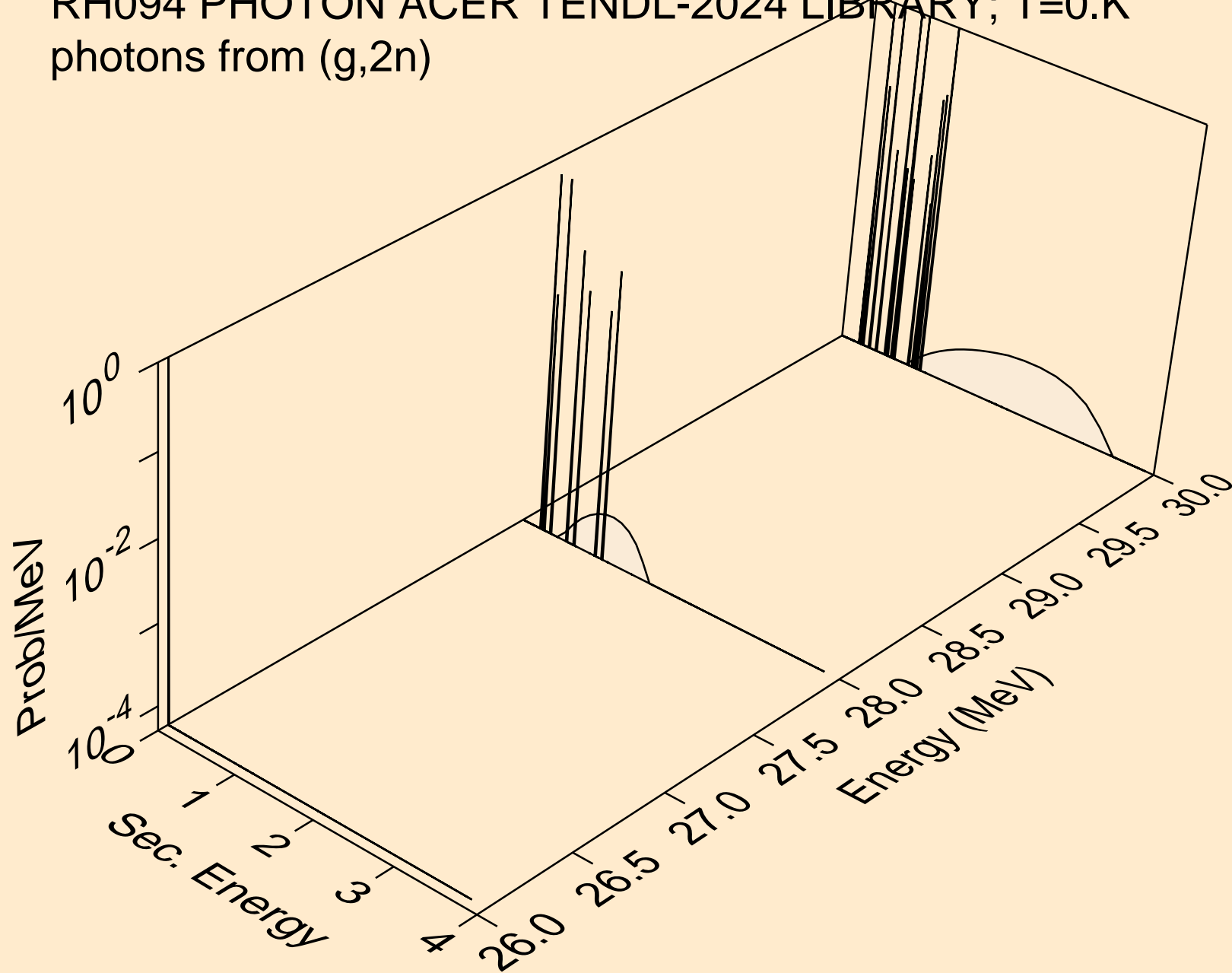

RH094 PHOTON ACER TENDL-2024 LIBRARY; T=0.K
photons from (g,n*)a

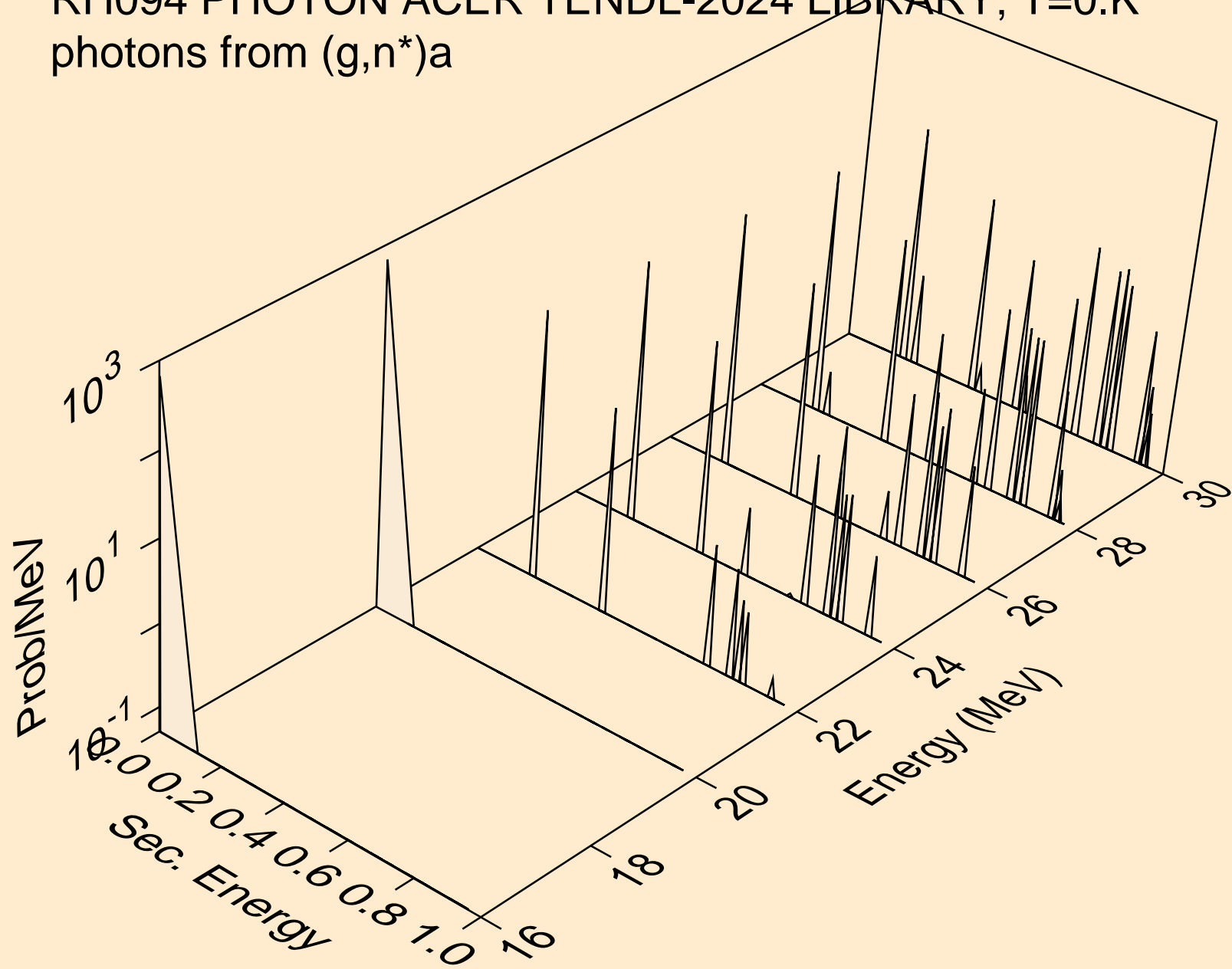

RH094 PHOTON ACER TENDL-2024 LIBRARY; T=0.K
photons from (g,n*)p

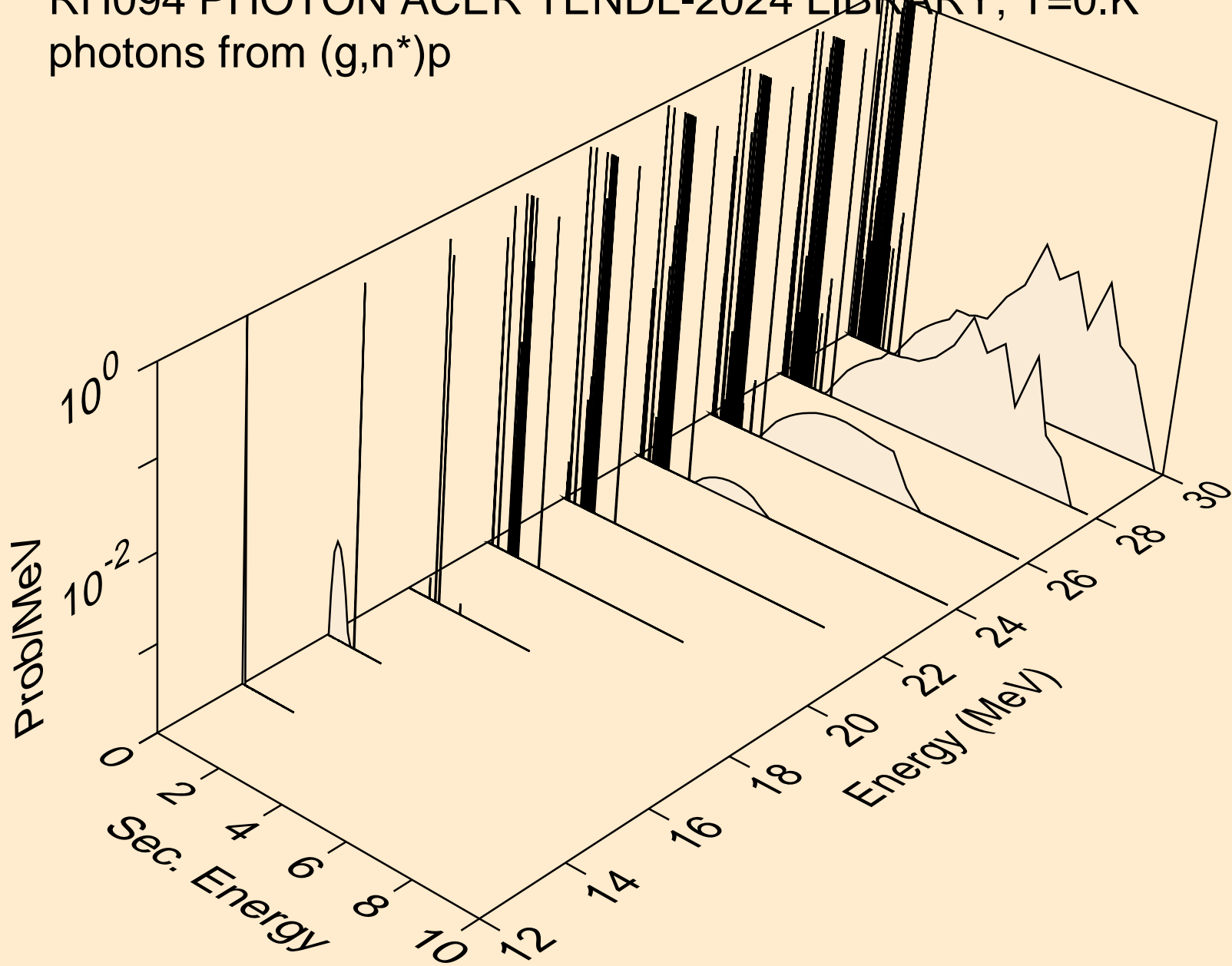

RH094 PHOTON ACER TENDL-2024 LIBRARY; T=0.K
photons from (g,n*)d

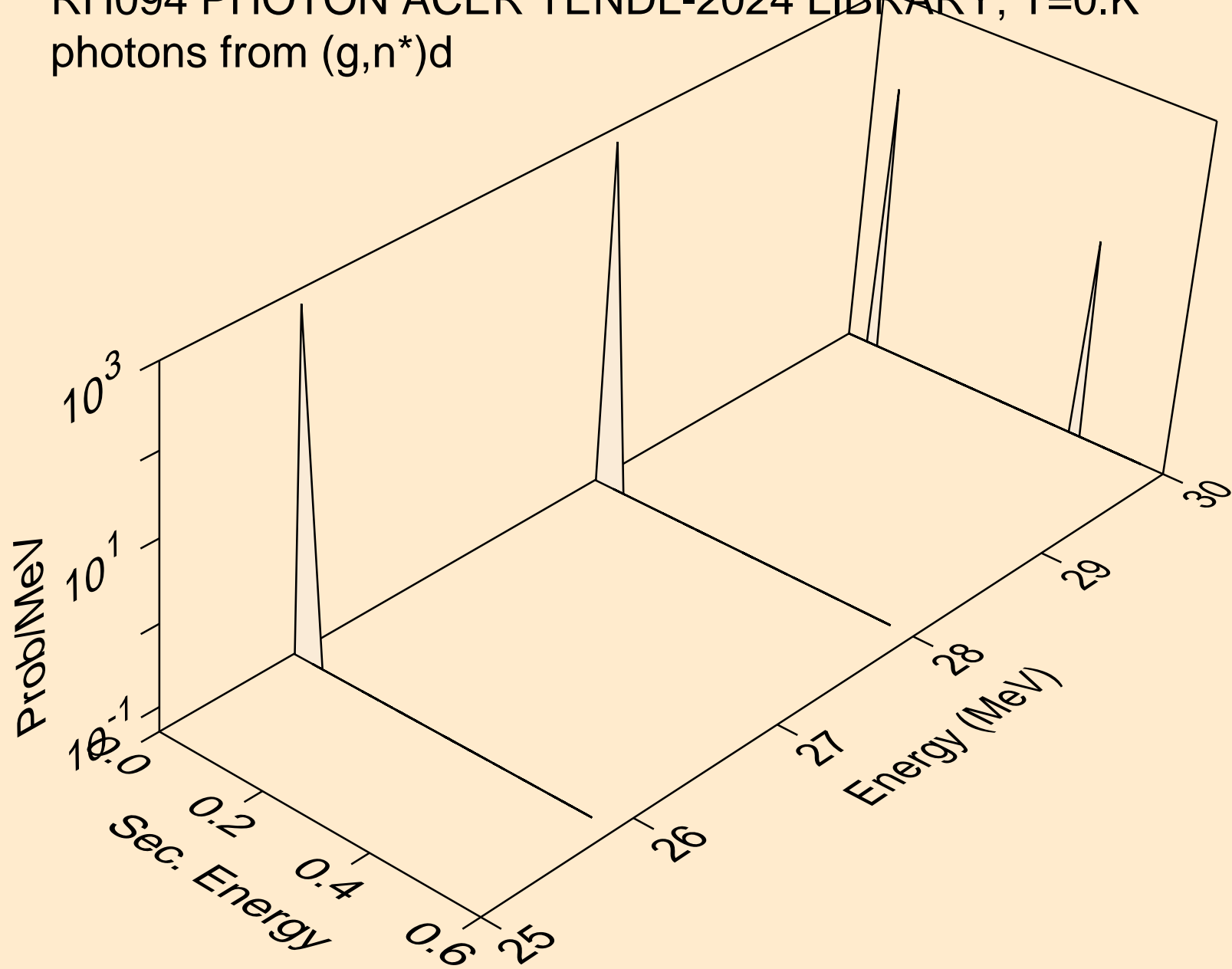

RH094 PHOTON ACER TENDL-2024 LIBRARY; T=0.K
photons from (g,n2p)

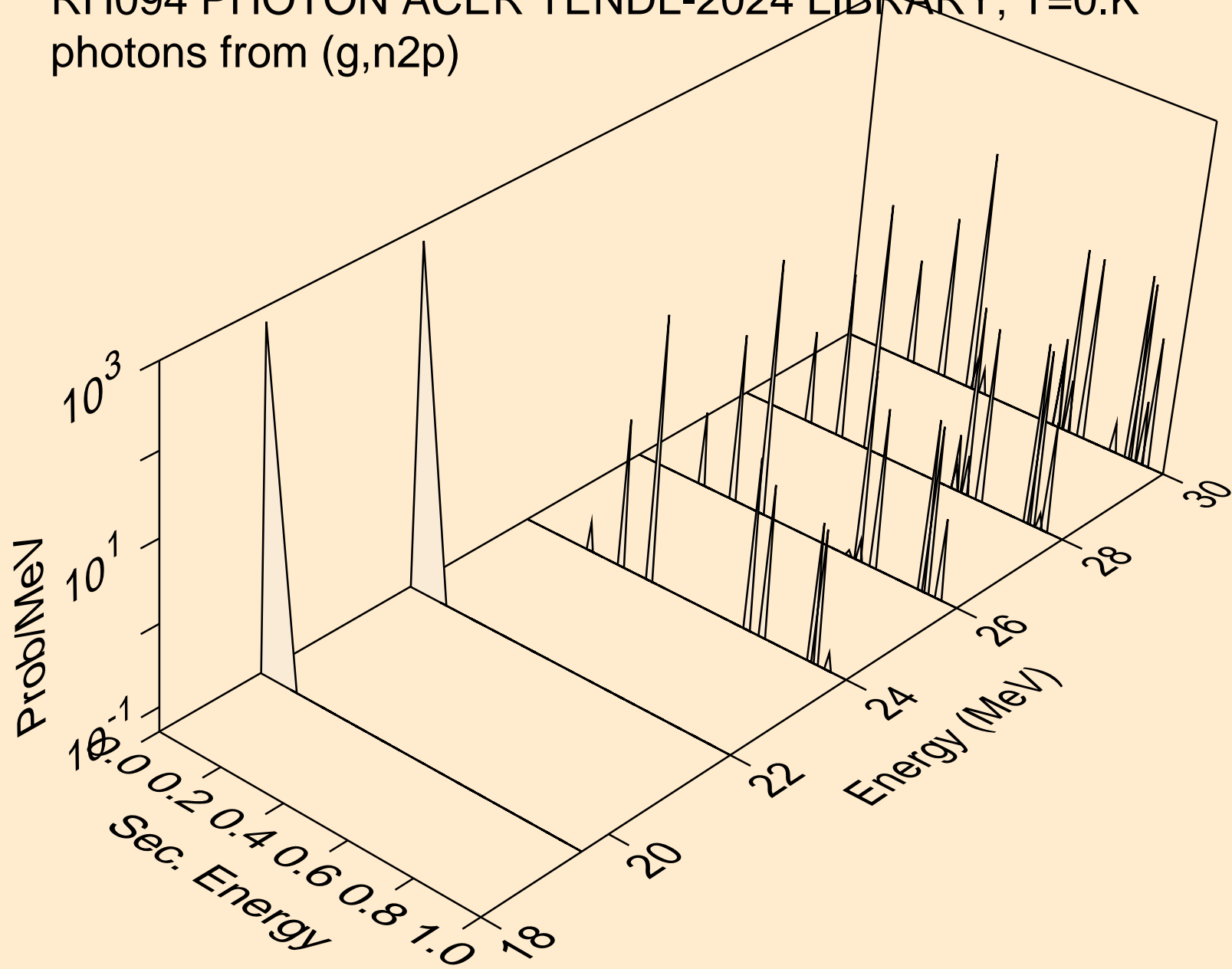

RH094 PHOTON ACER TENDL-2024 LIBRARY; T=0.K
photons from (g,npa)

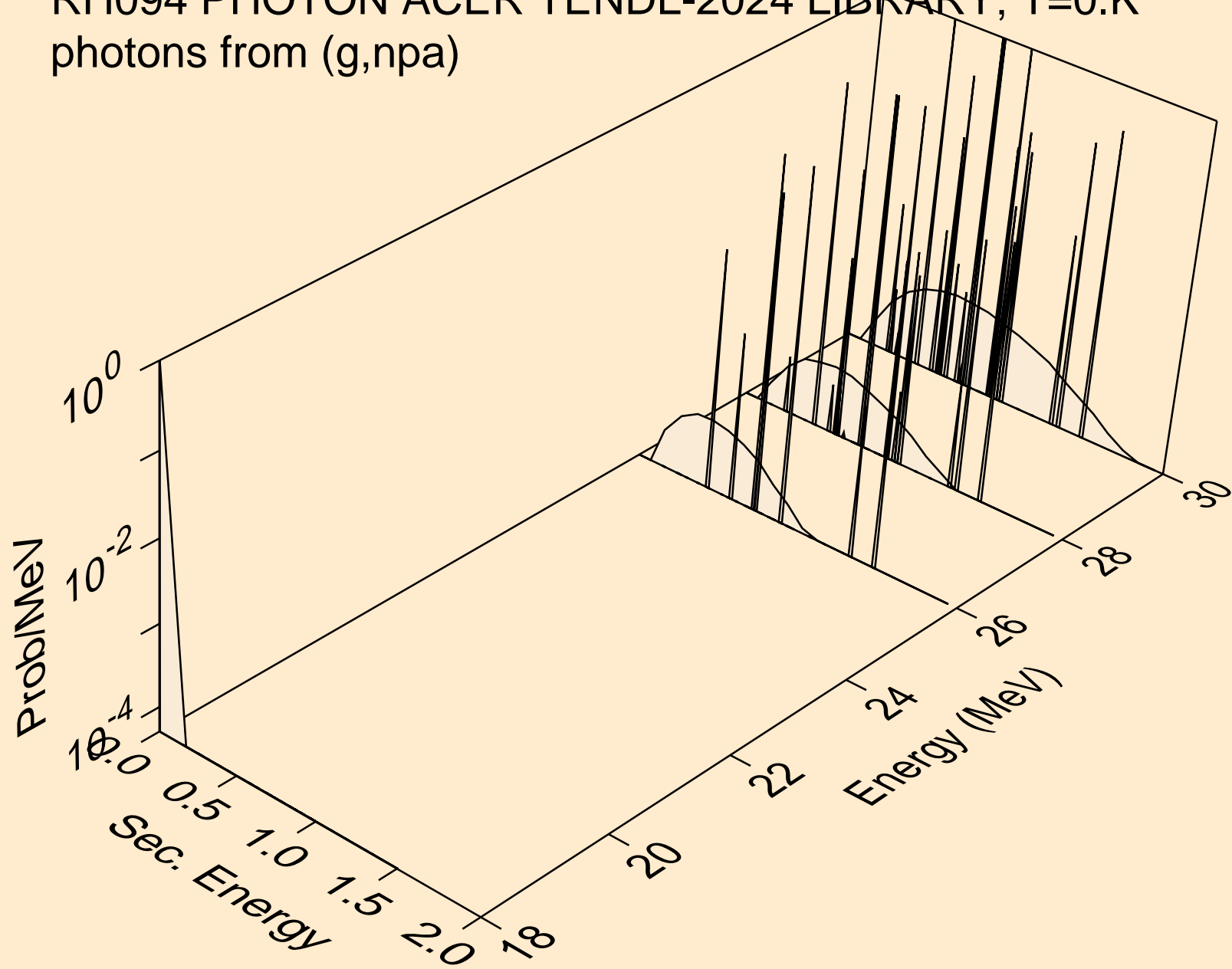

RH094 PHOTON ACER TENDL-2024 LIBRARY; T=0.K
photons from (g,n*c)

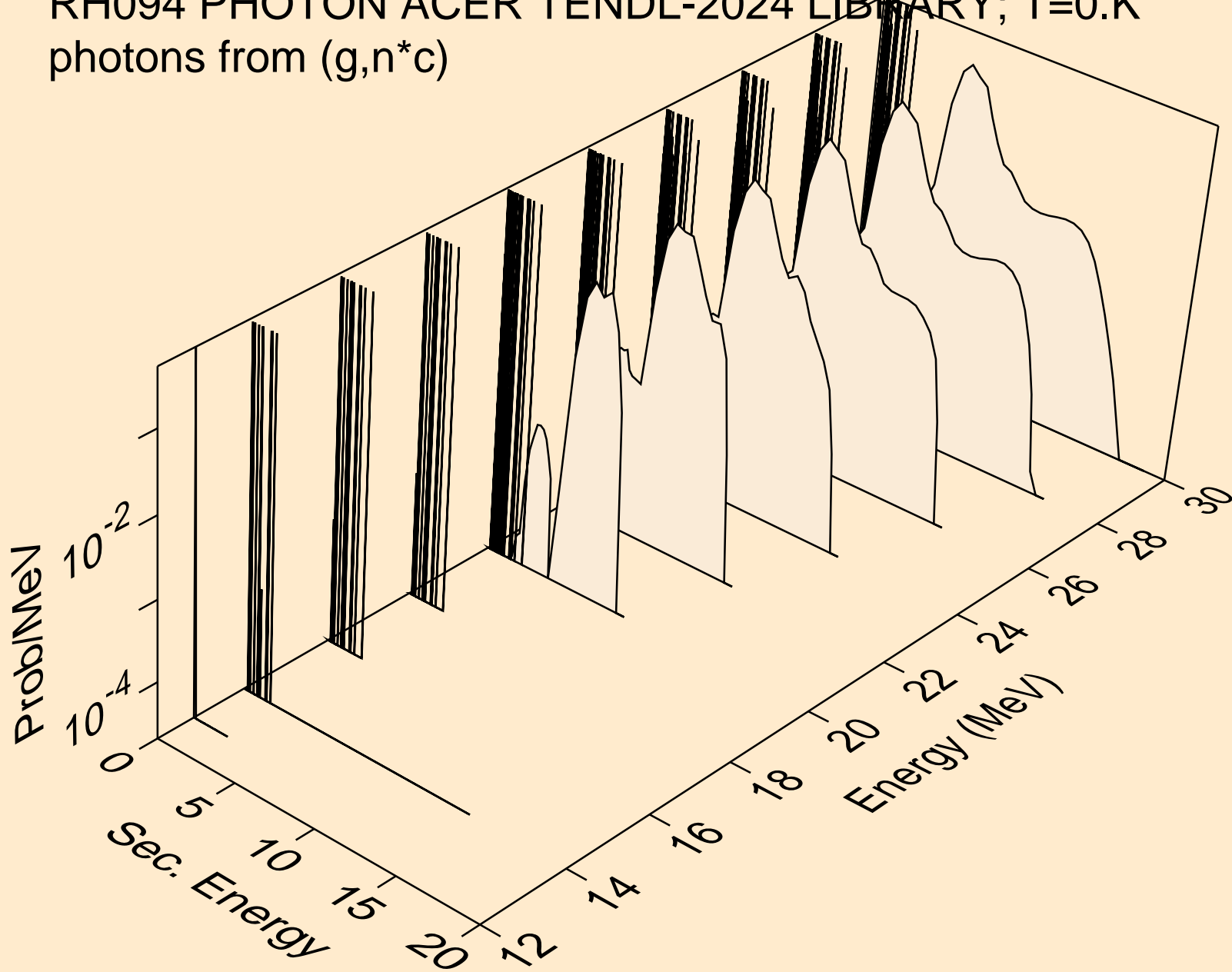

RH094 PHOTON ACER TENDL-2024 LIBRARY; T=0.K
photons from (g,gma)

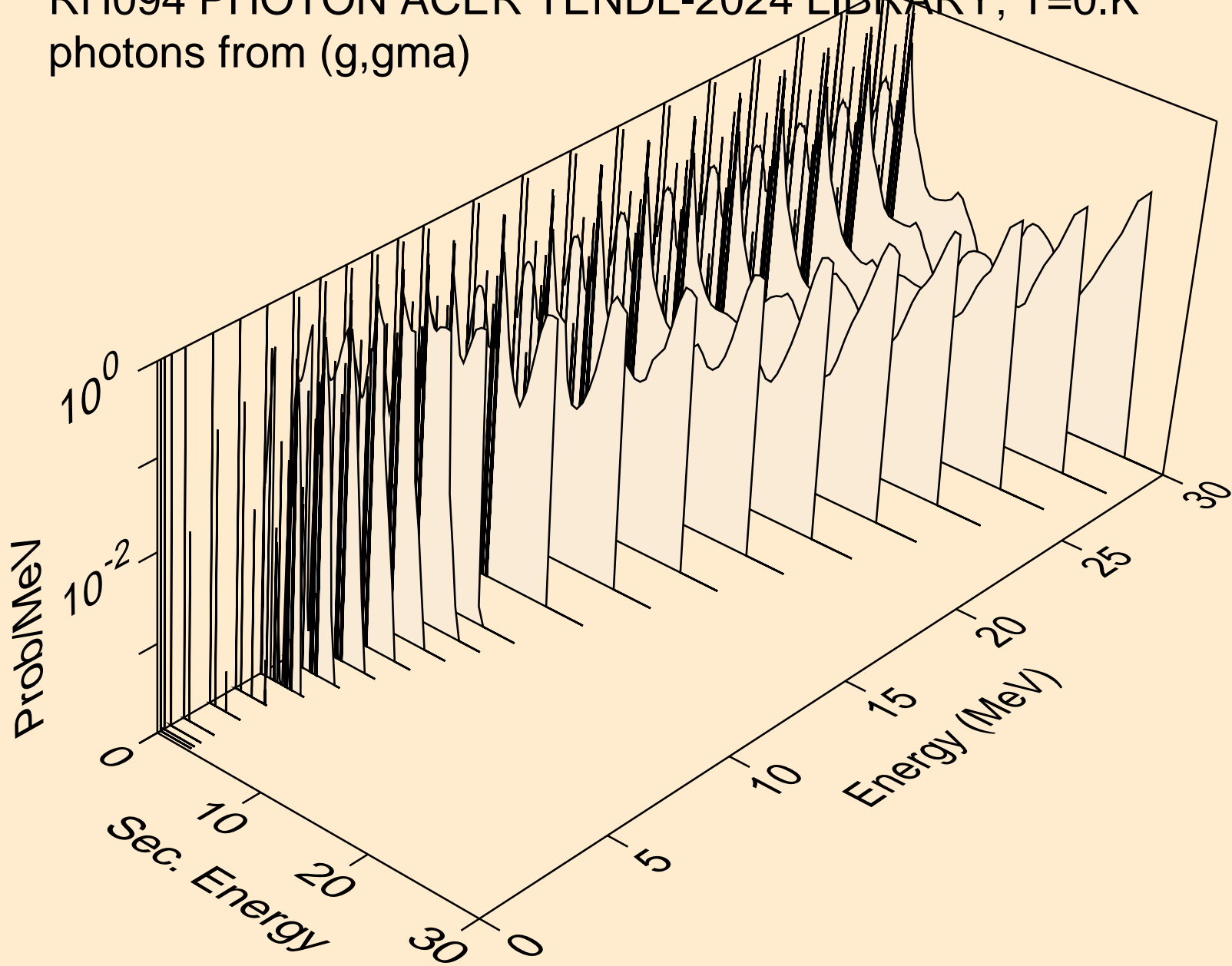

RH094 PHOTON ACER TENDL-2024 LIBRARY; T=0.K
photons from (g,p)

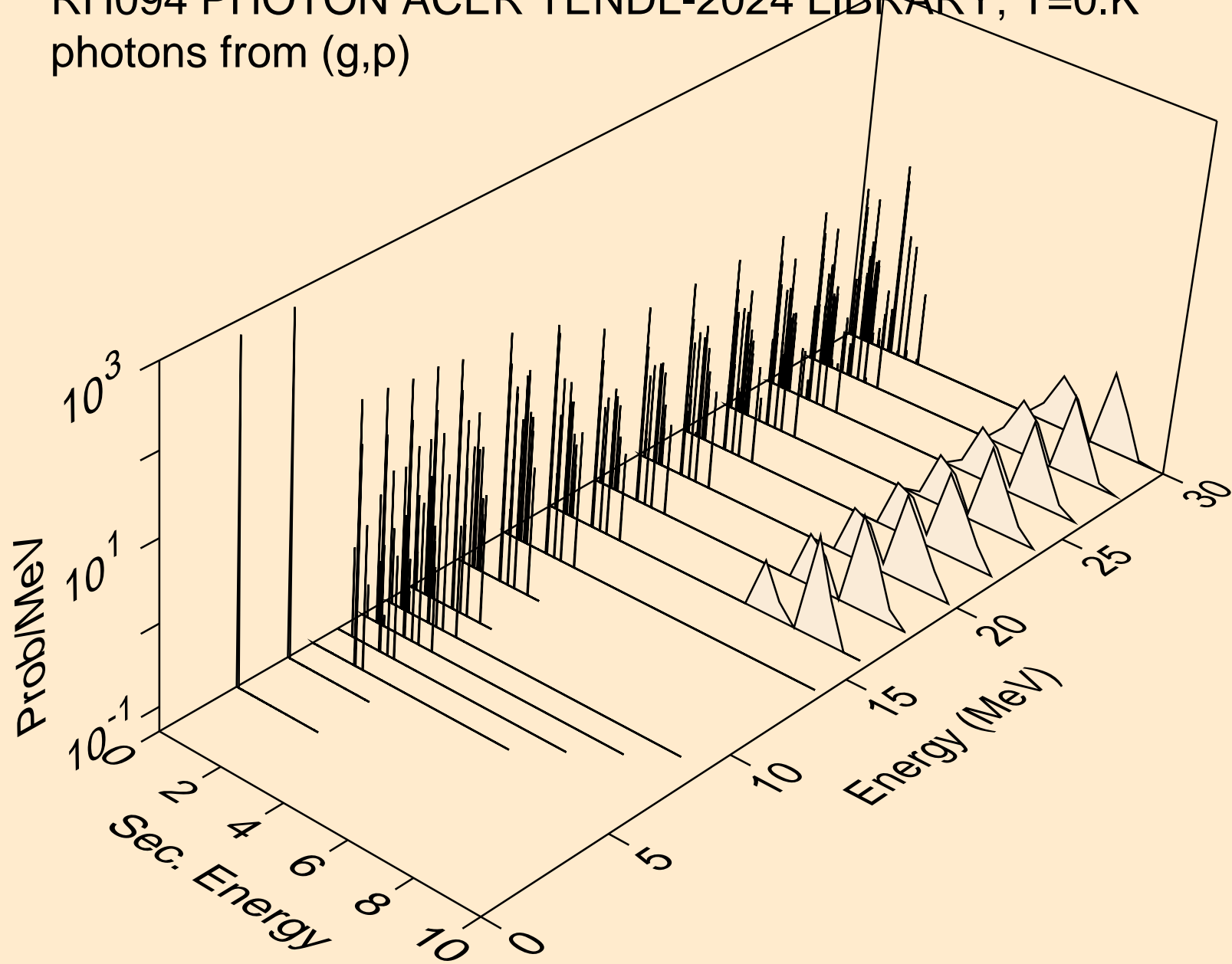

RH094 PHOTON ACER TENDL-2024 LIBRARY; T=0.K
photons from (g,d)

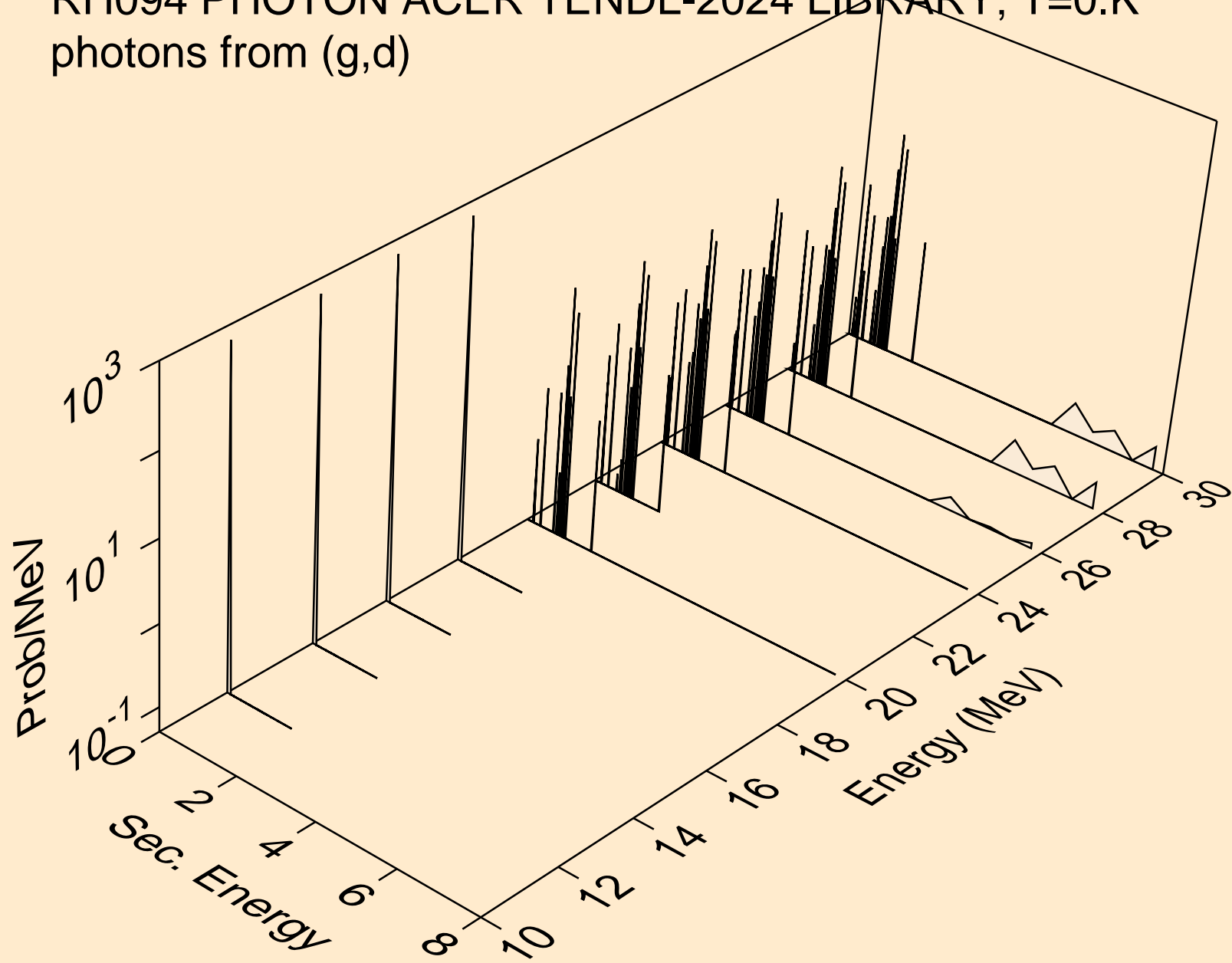

RH094 PHOTON ACER TENDL-2024 LIBRARY; T=0.K
photons from (g,t)

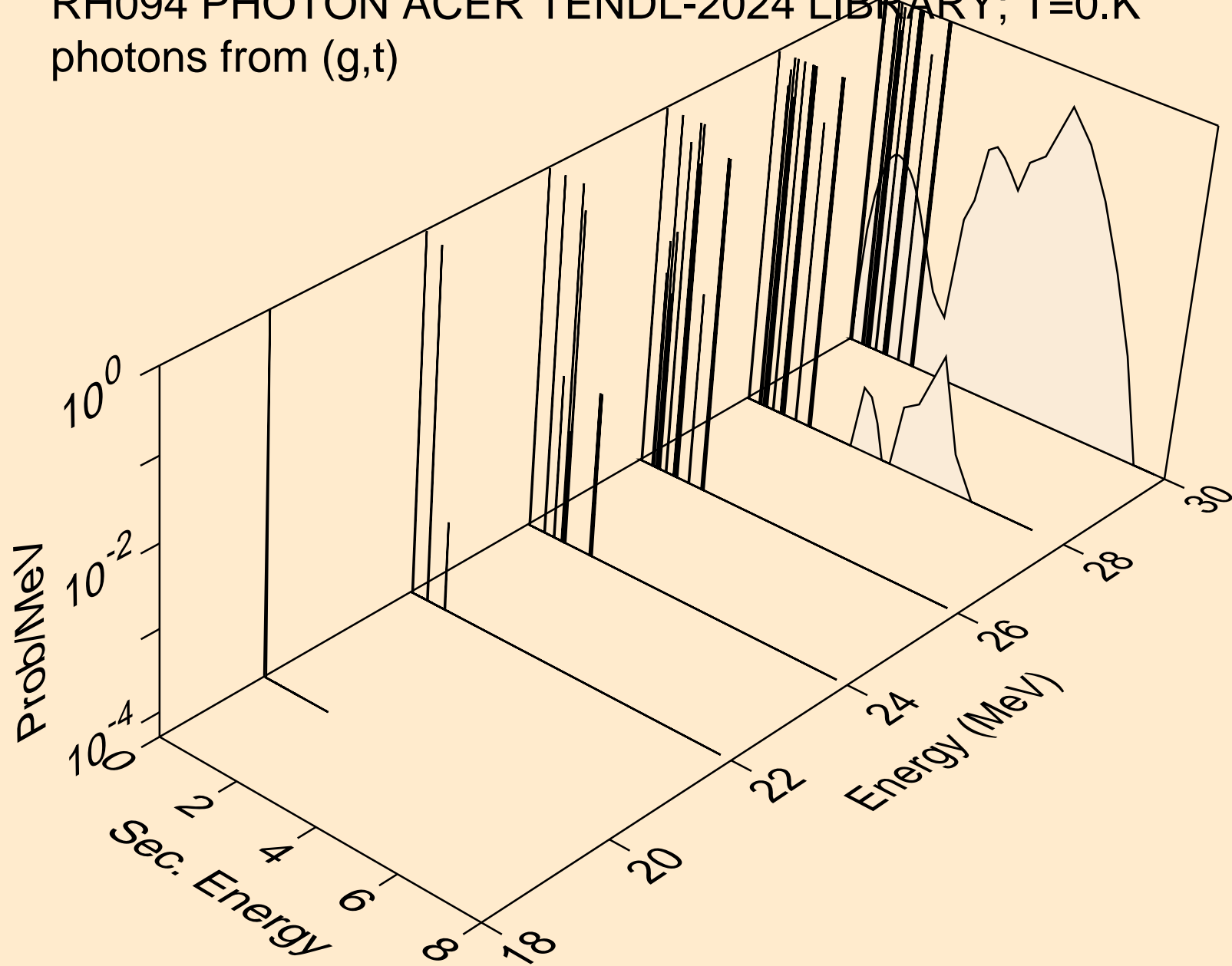

RH094 PHOTON ACER TENDL-2024 LIBRARY; T=0.K
photons from (g,he3)

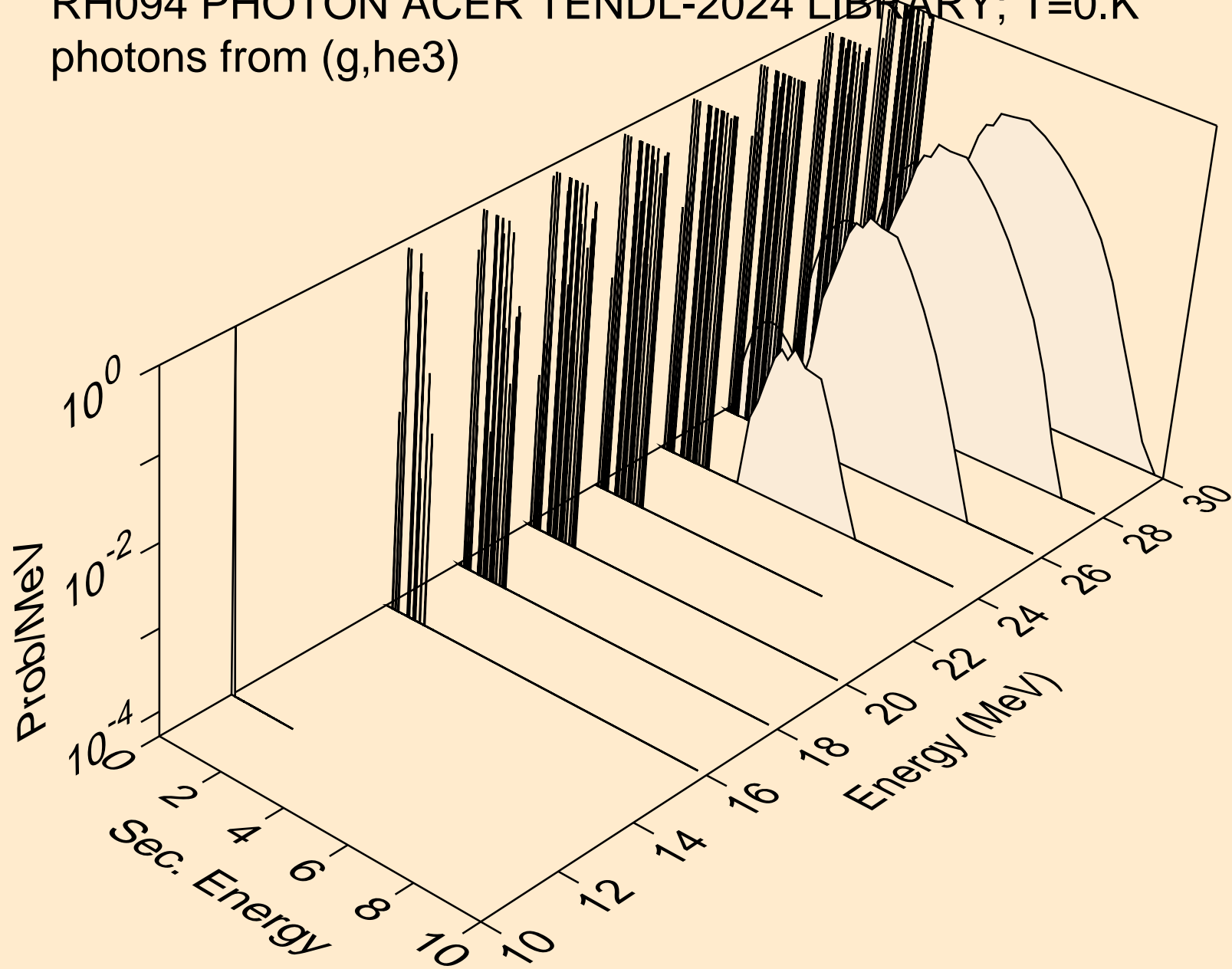

RH094 PHOTON ACER TENDL-2024 LIBRARY; T=0.K
photons from (g,a)

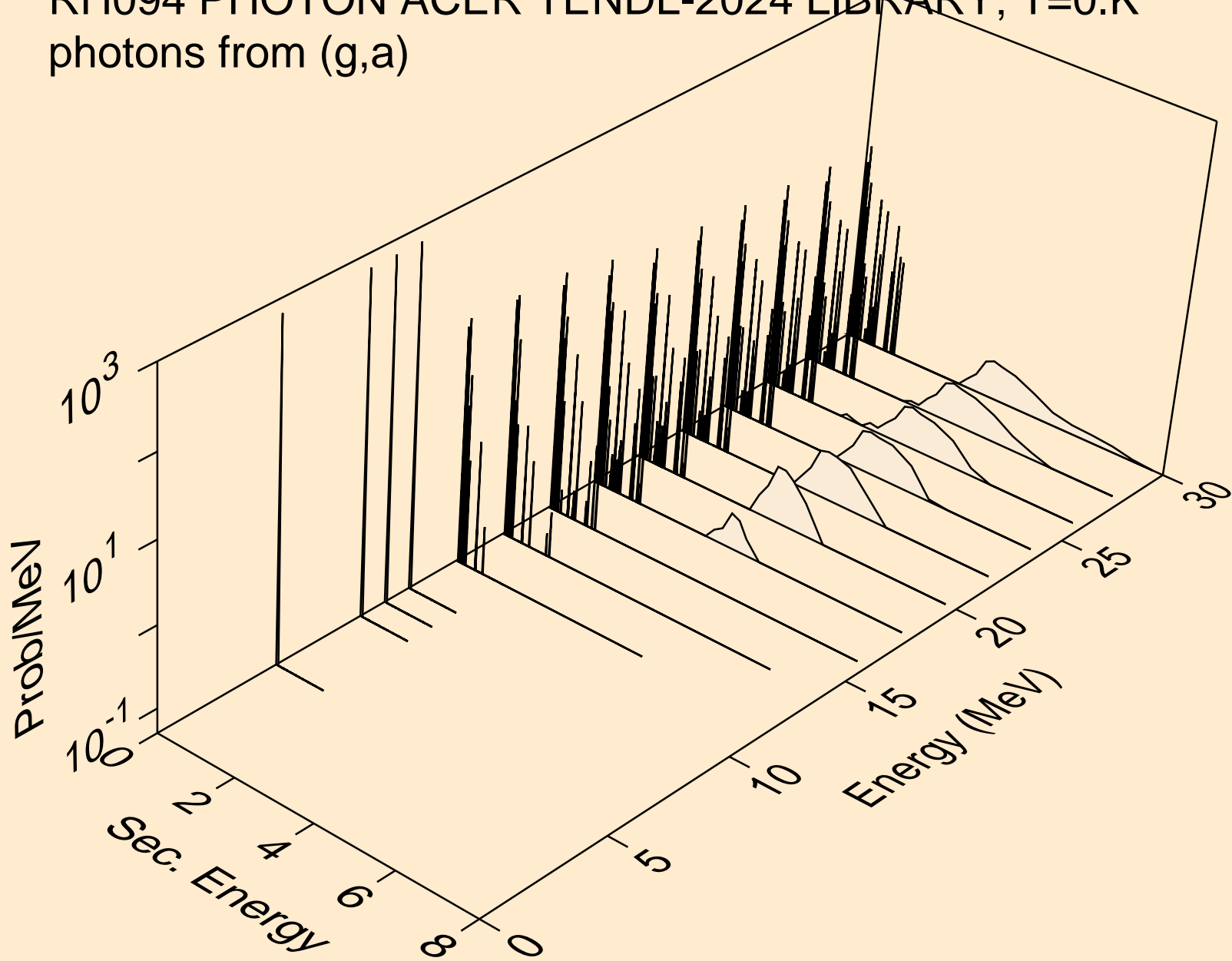

RH094 PHOTON ACER TENDL-2024 LIBRARY; T=0.K
photons from (g,2a)

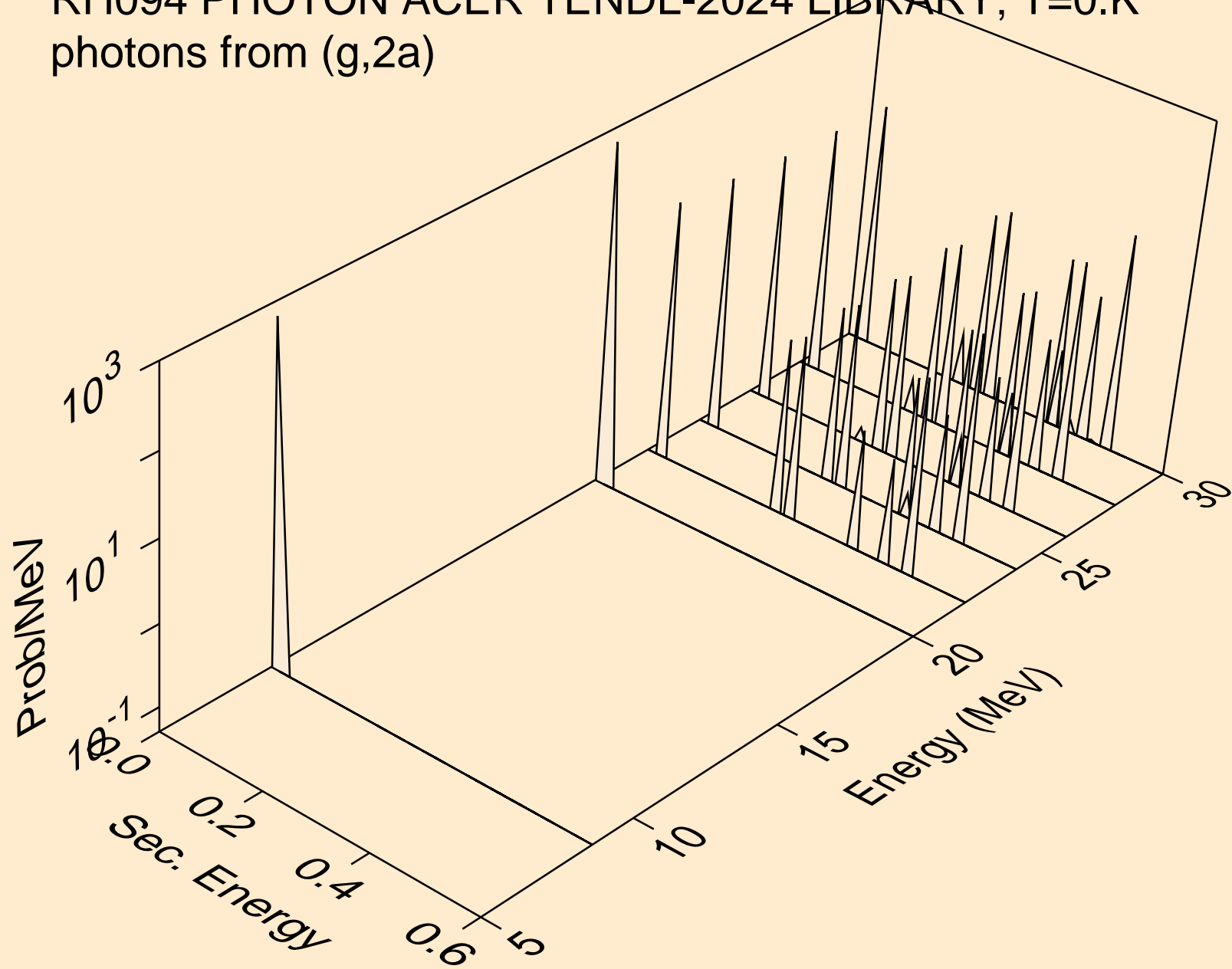

RH094 PHOTON ACER TENDL-2024 LIBRARY; T=0.K
photons from (g,2p)

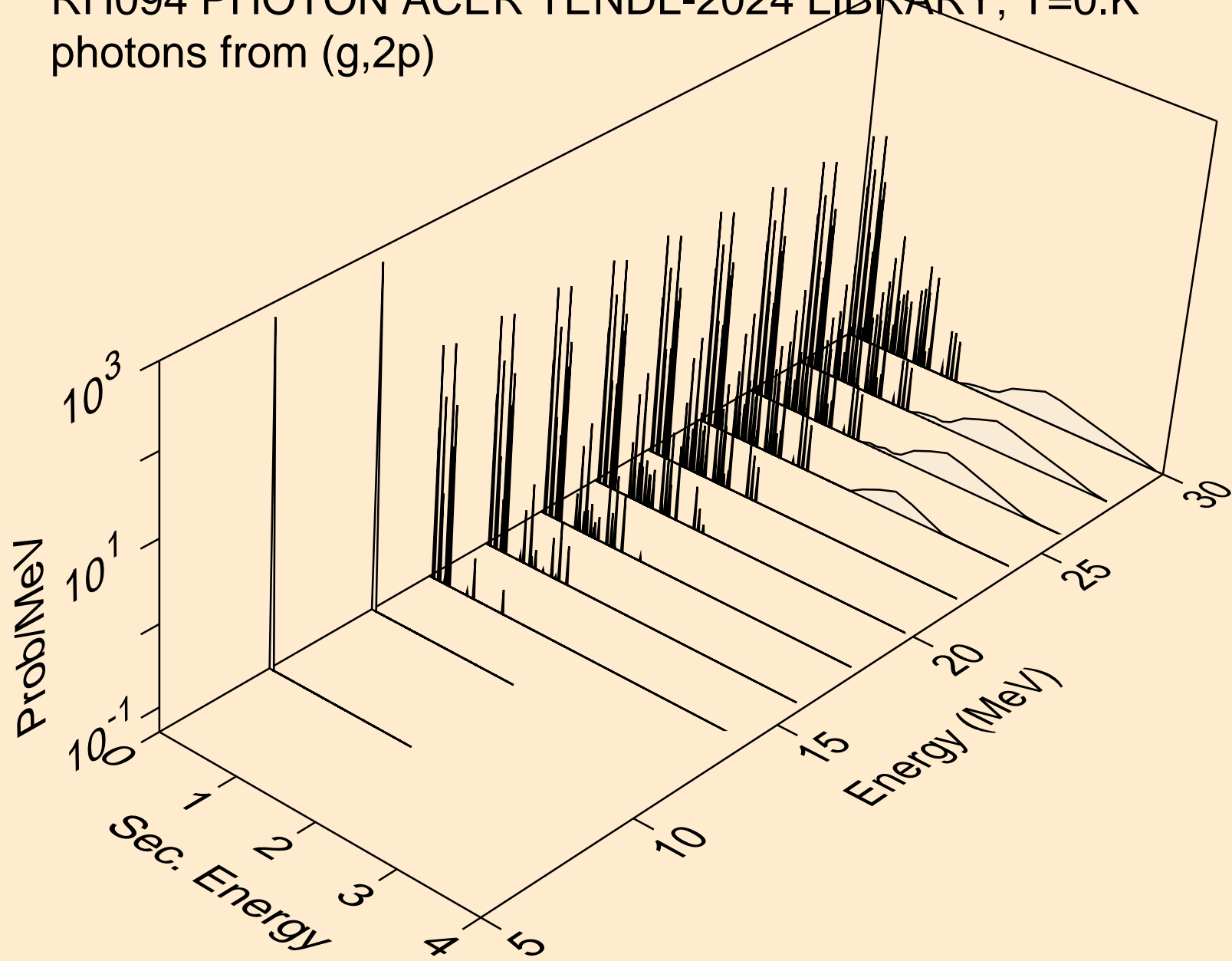

RH094 PHOTON ACER TENDL-2024 LIBRARY; T=0.K
photons from (g,pa)

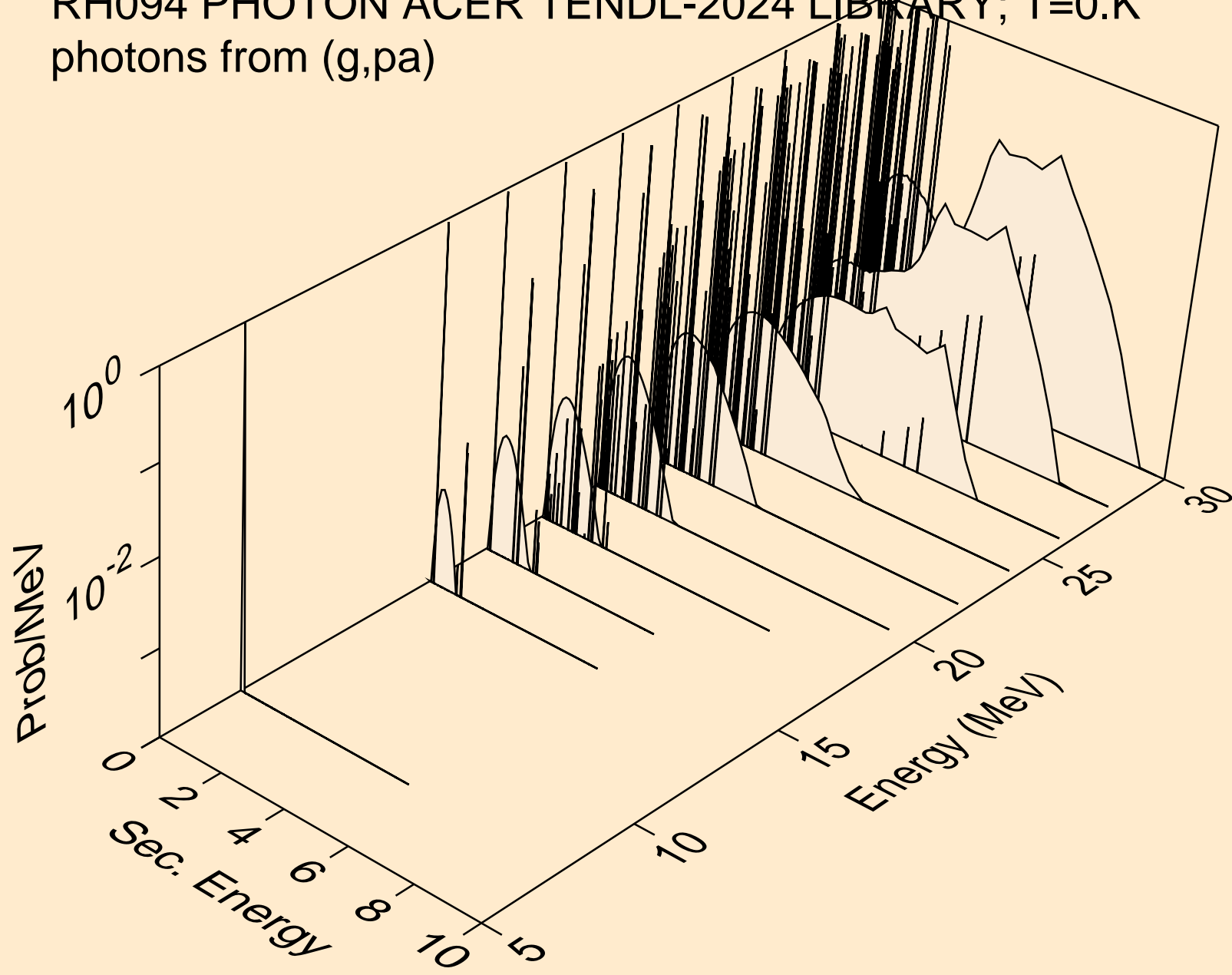

RH094 PHOTON ACER TENDL-2024 LIBRARY; T=0.K
photons from (g,pd)

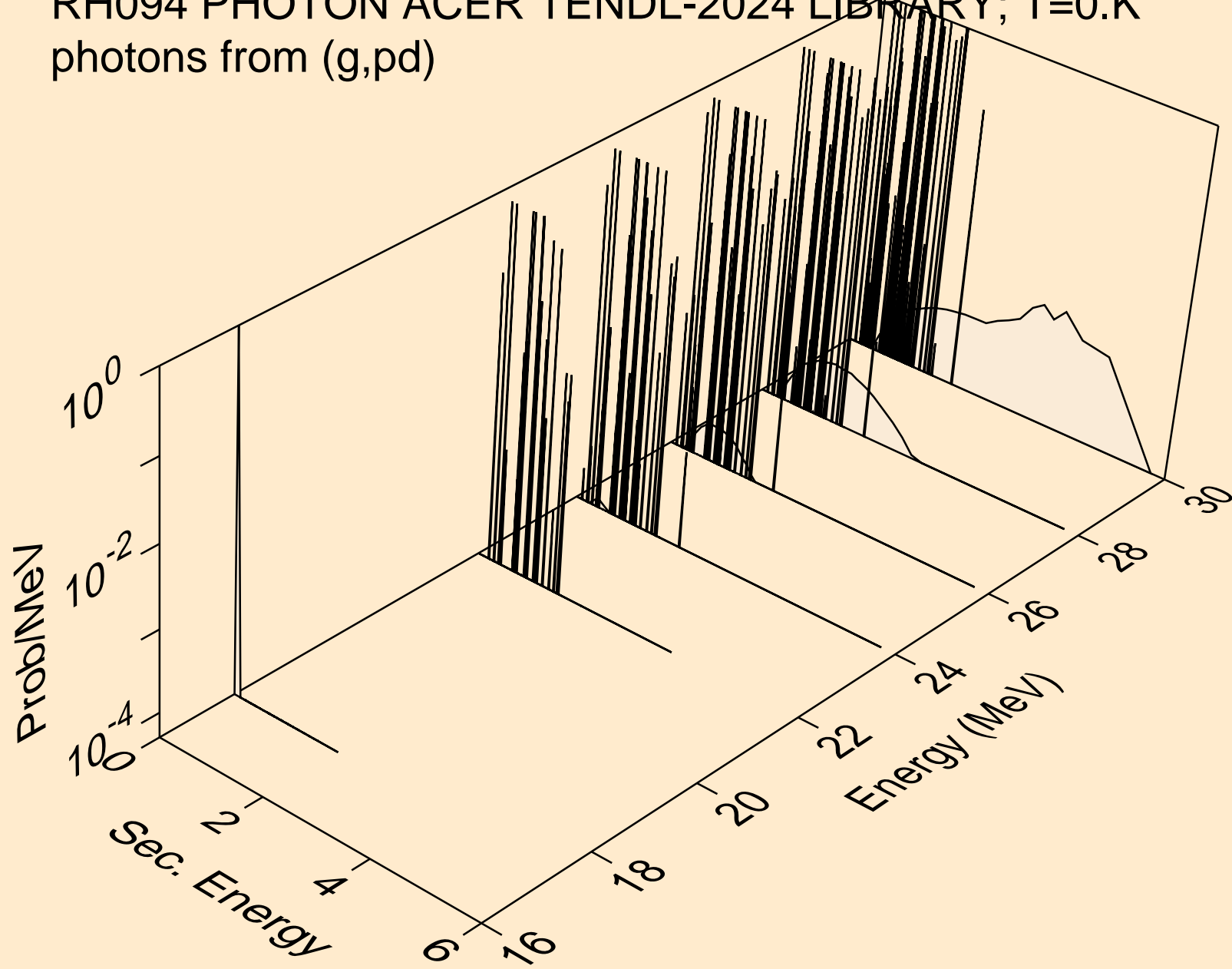

RH094 PHOTON ACER TENDL-2024 LIBRARY; T=0.K
protons from (g,x)

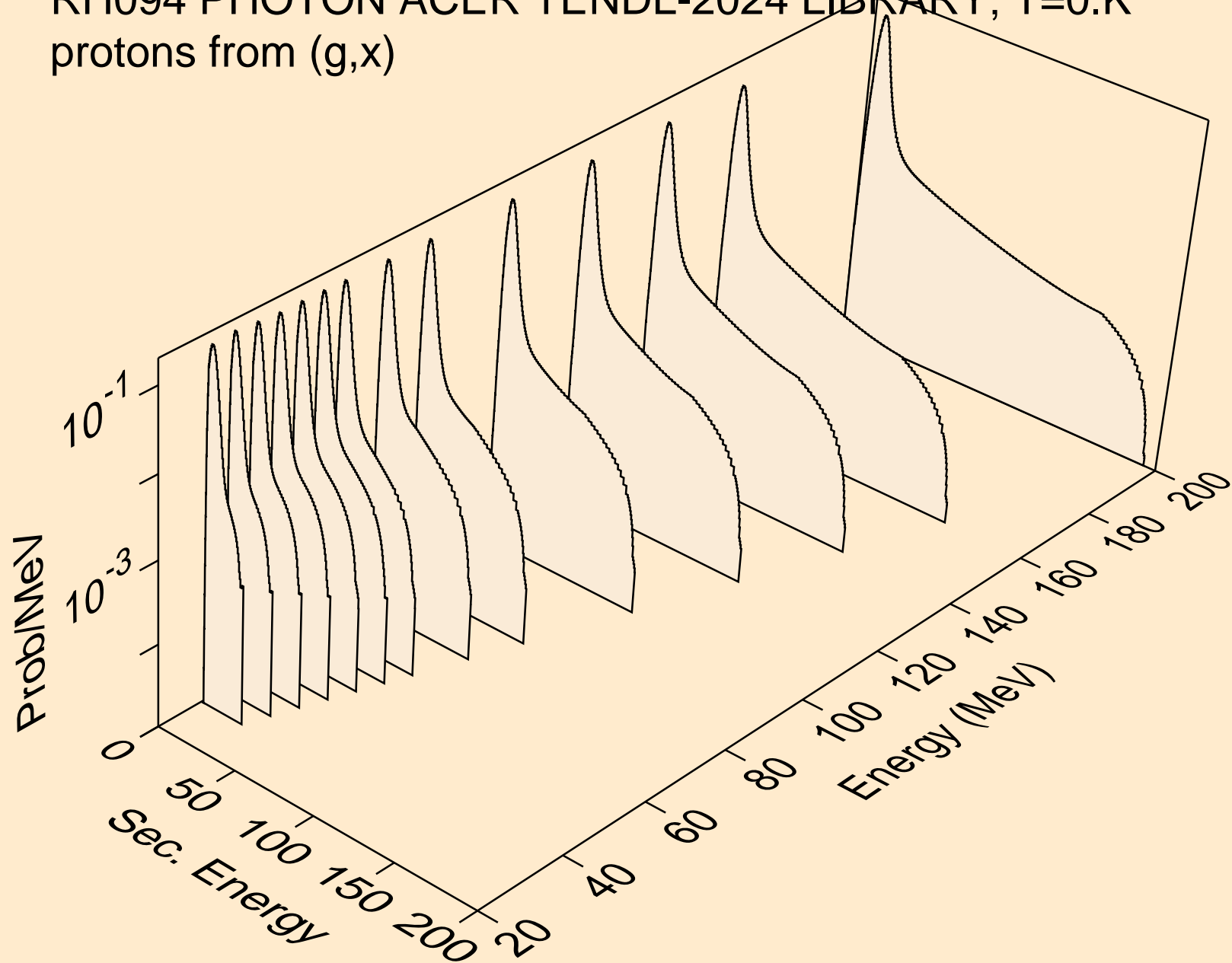

RH094 PHOTON ACER TENDL-2024 LIBRARY; T=0.K
protons from (g,n*)p

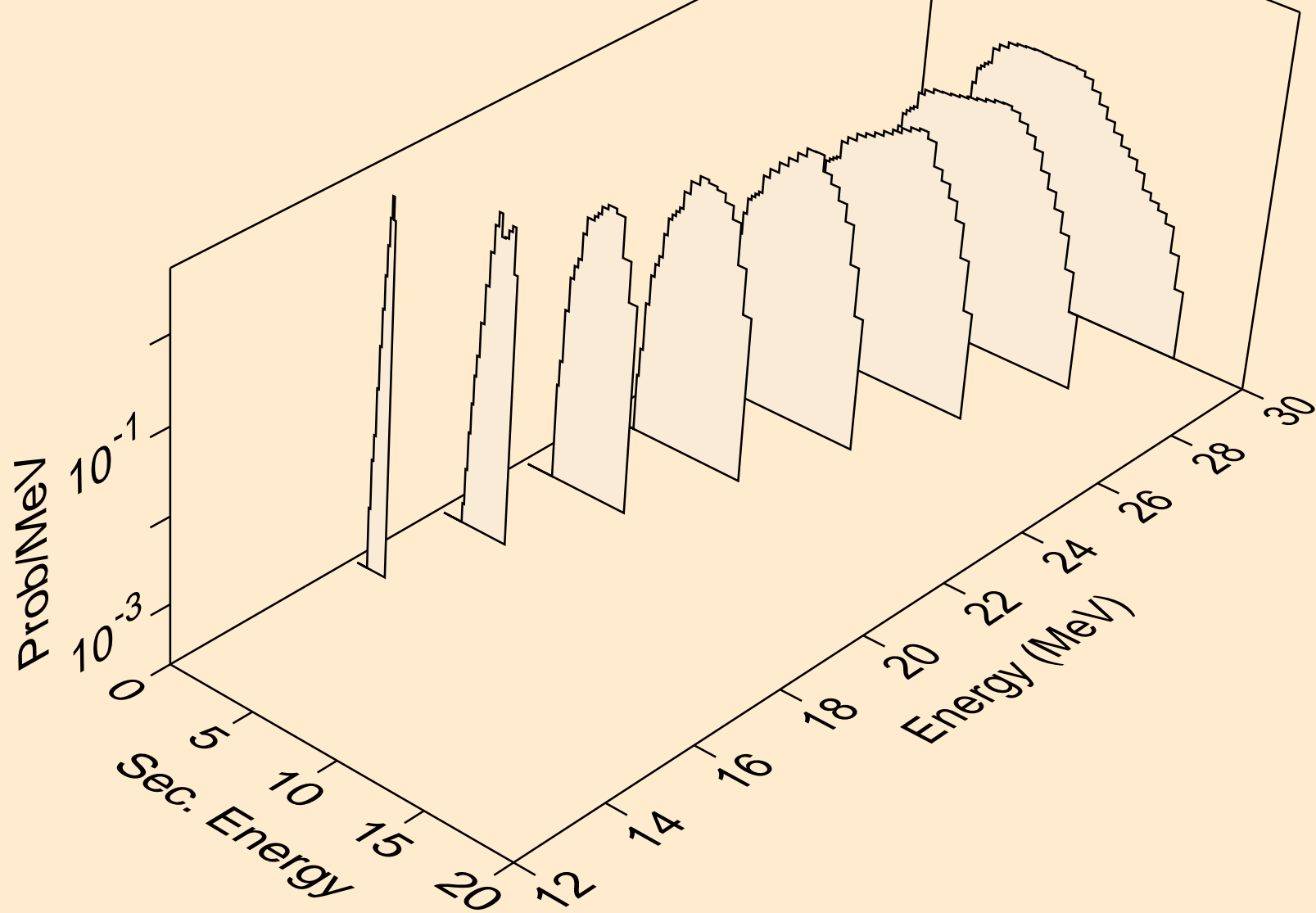

RH094 PHOTON ACER TENDL-2024 LIBRARY; T=0.K
protons from (g,n2p)

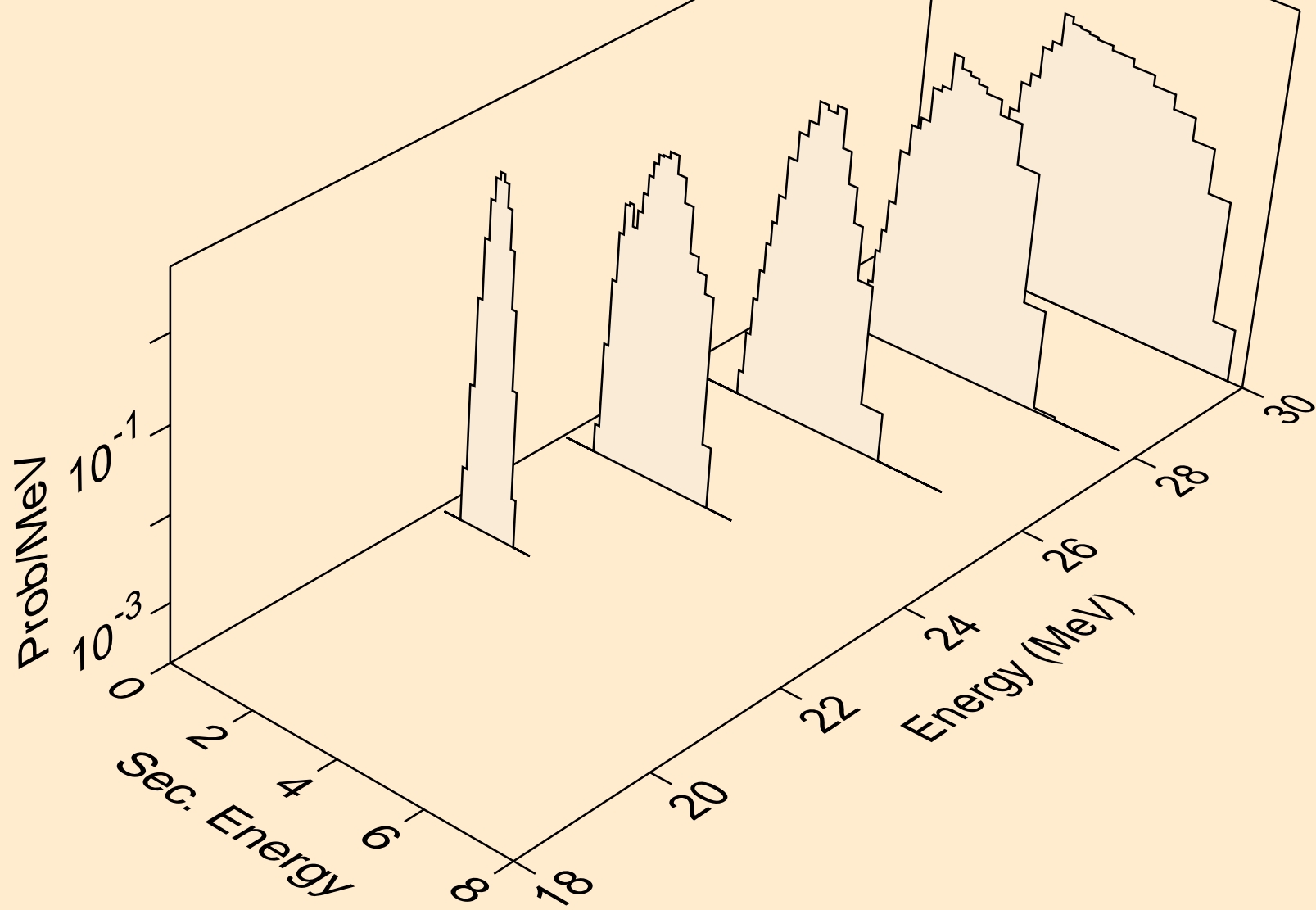

RH094 PHOTON ACER TENDL-2024 LIBRARY; T=0.K
protons from (g,npa)

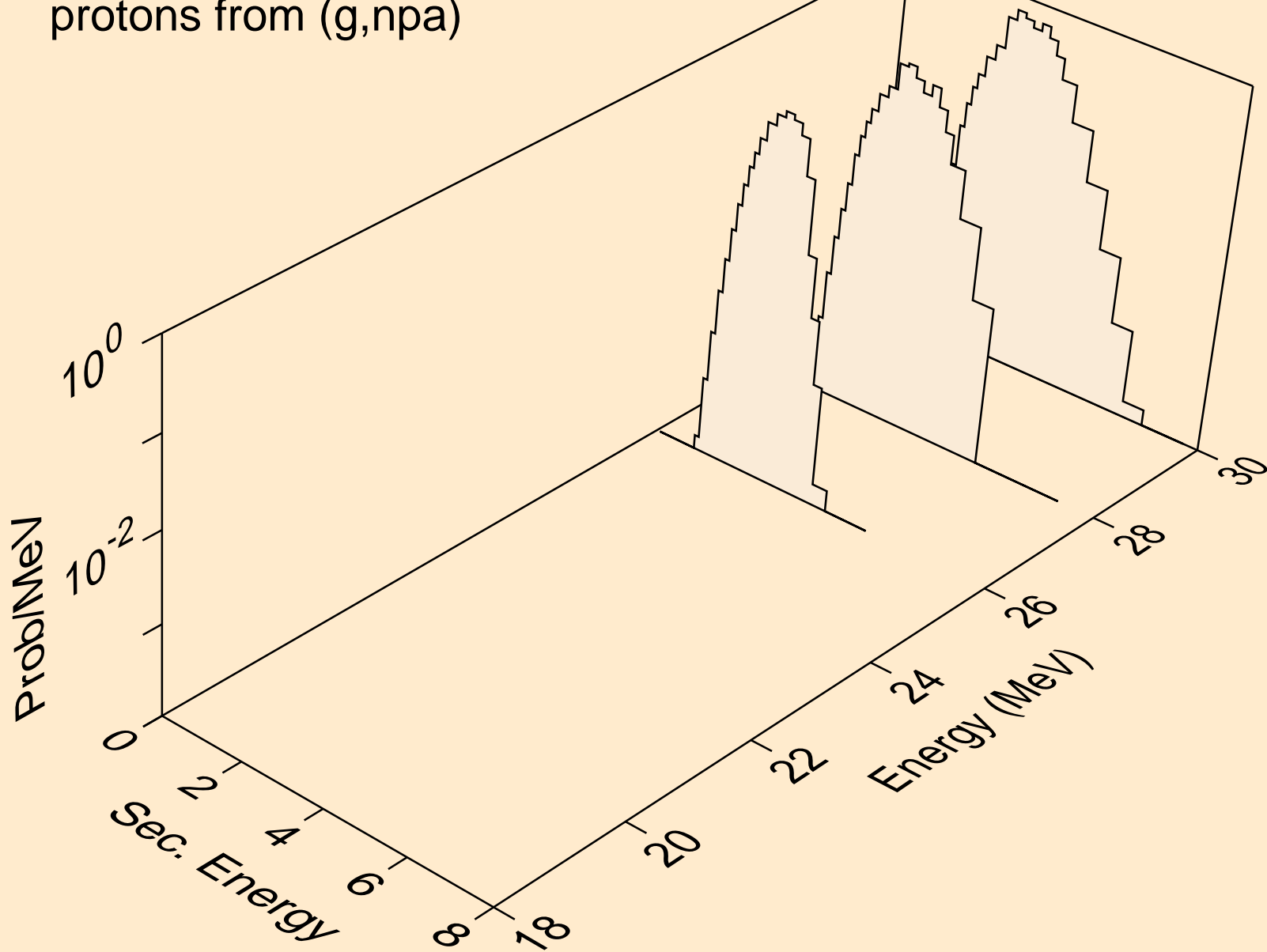

RH094 PHOTON ACER TENDL-2024 LIBRARY; T=0.K
protons from (g,p)

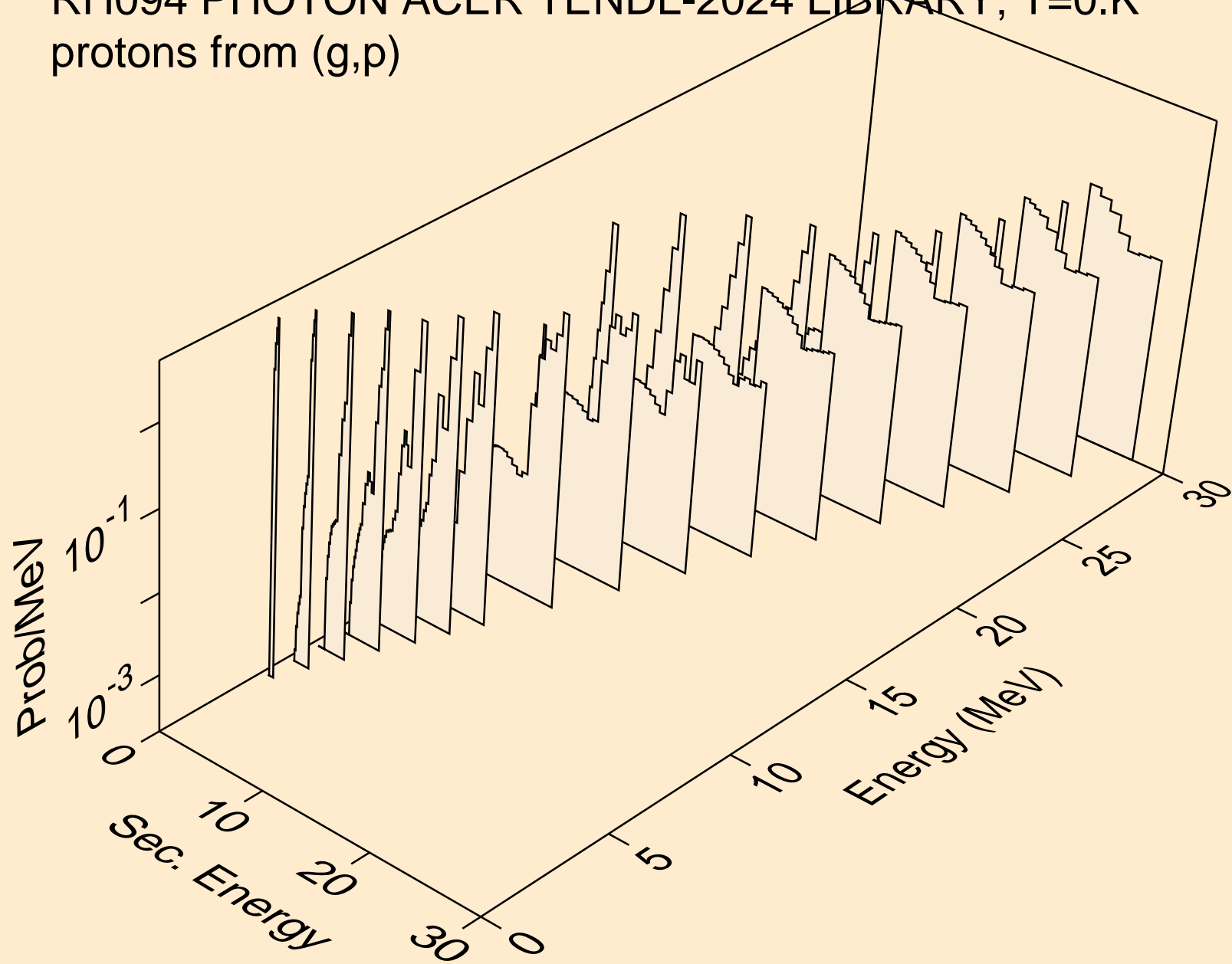

RH094 PHOTON ACER TENDL-2024 LIBRARY; T=0.K
protons from (g,2p)

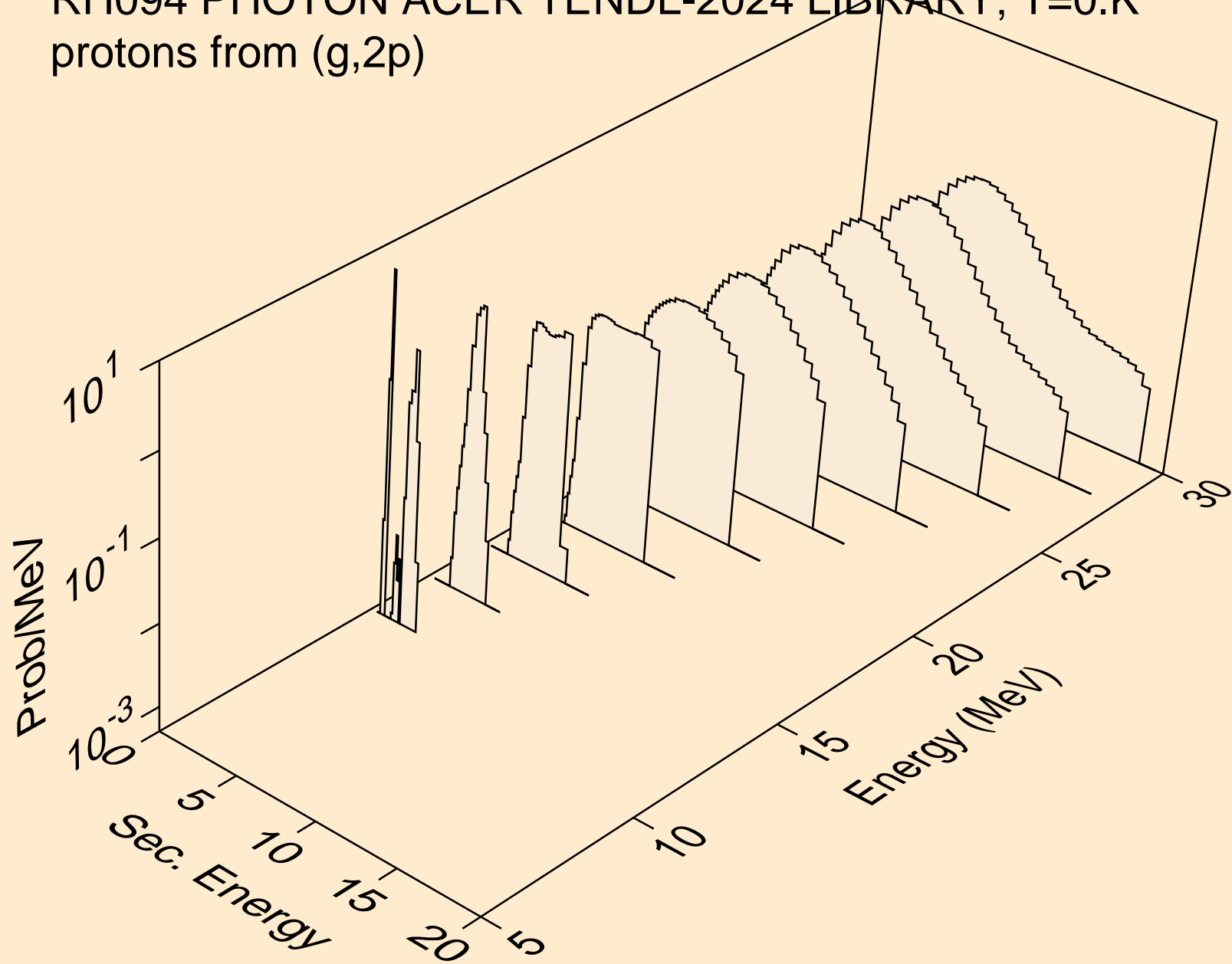

RH094 PHOTON ACER TENDL-2024 LIBRARY; T=0.K
protons from (g,pa)

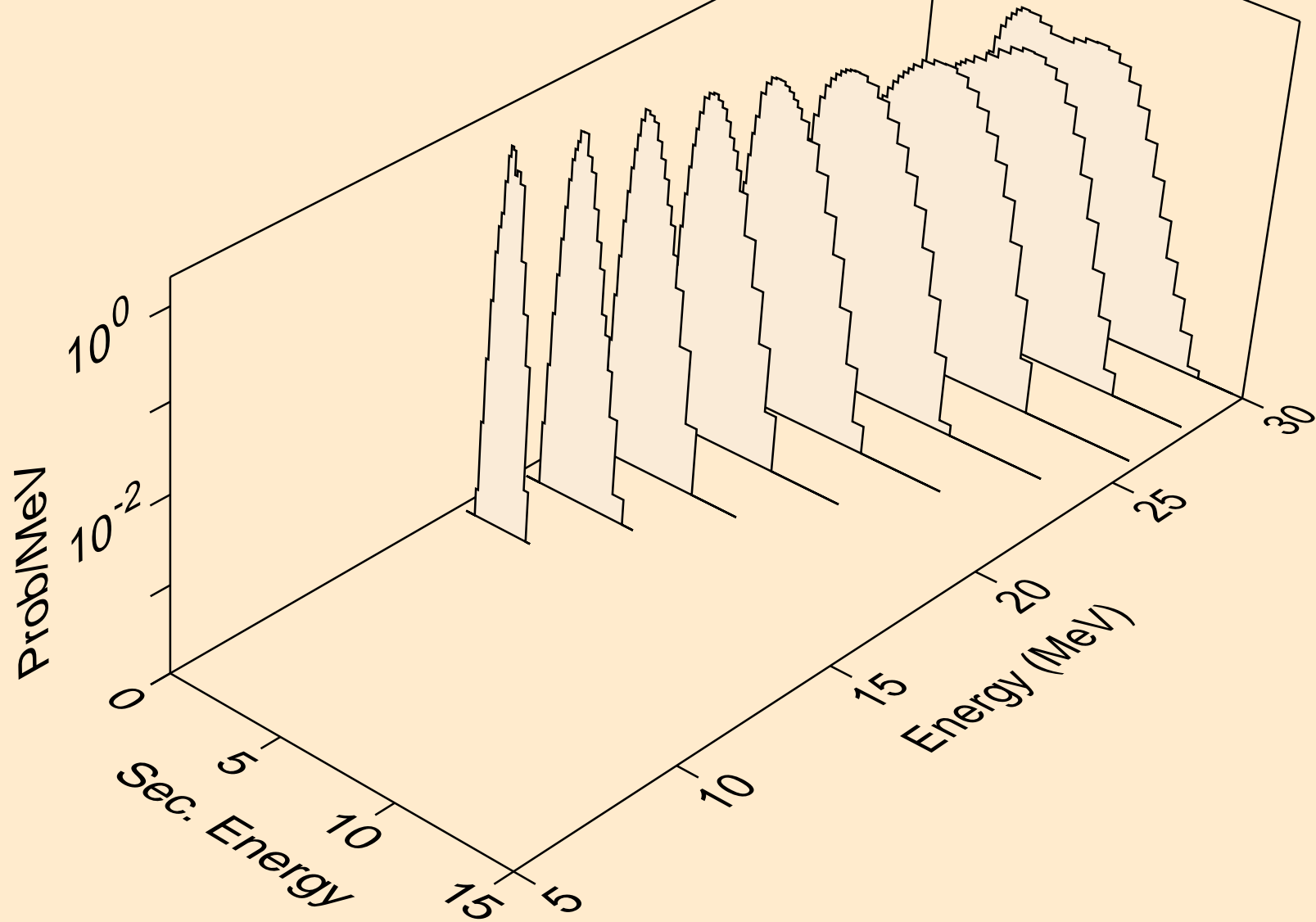

RH094 PHOTON ACER TENDL-2024 LIBRARY; T=0.K
protons from (g,pd)

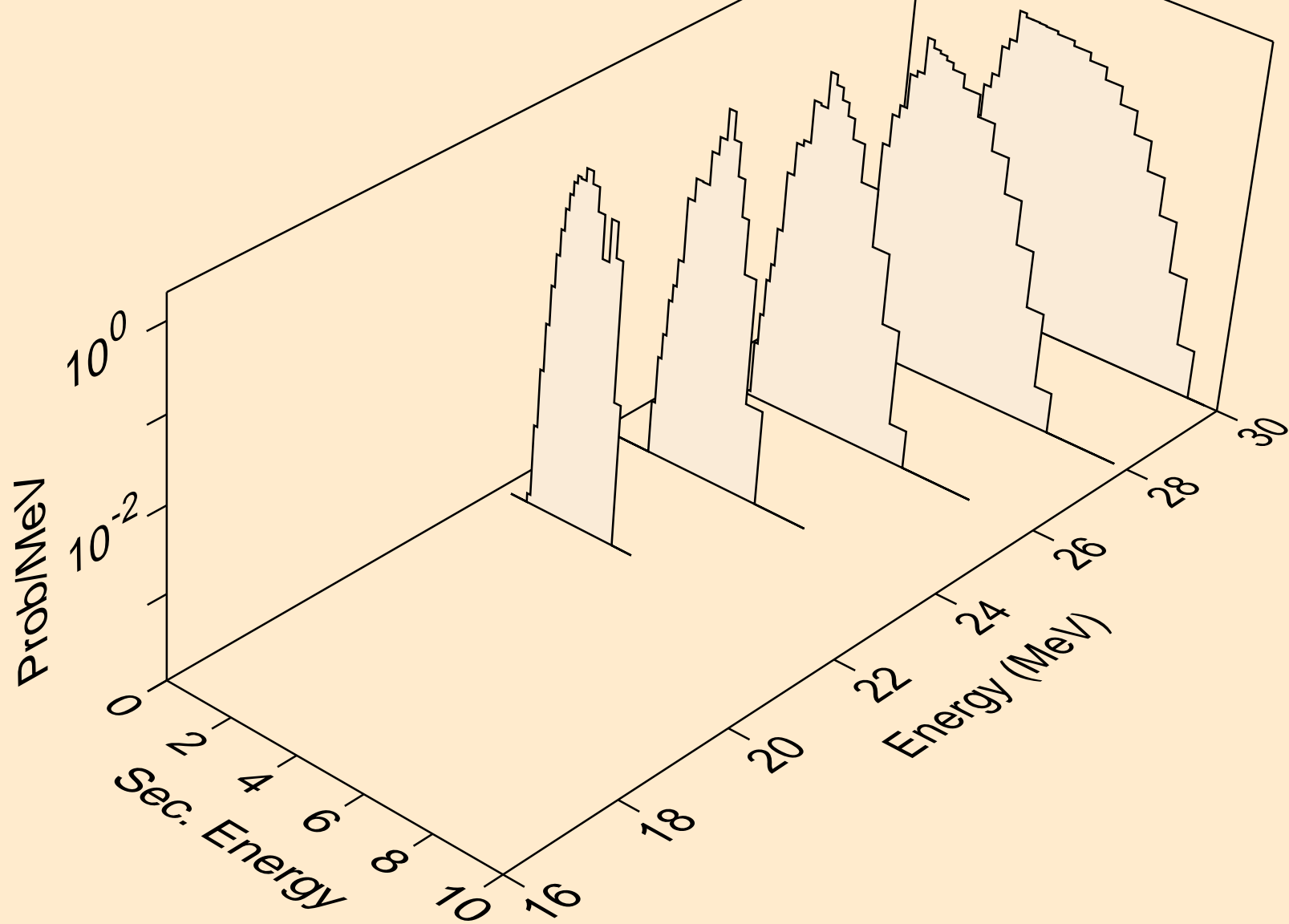

RH094 PHOTON ACER TENDL-2024 LIBRARY; T=0.K
deuterons from (g,x)

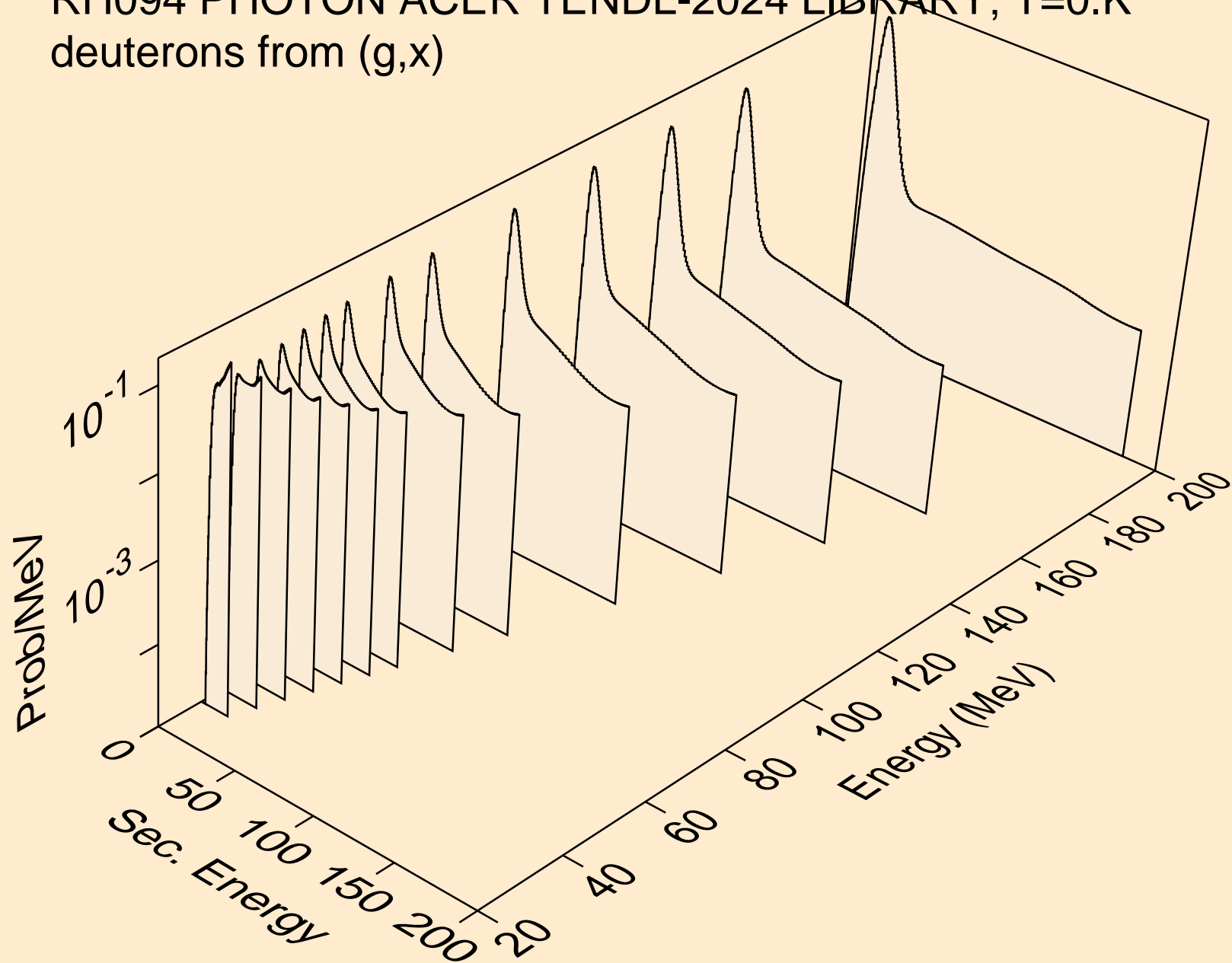

RH094 PHOTON ACER TENDL-2024 LIBRARY; T=0.K
deuterons from (g,n*)d

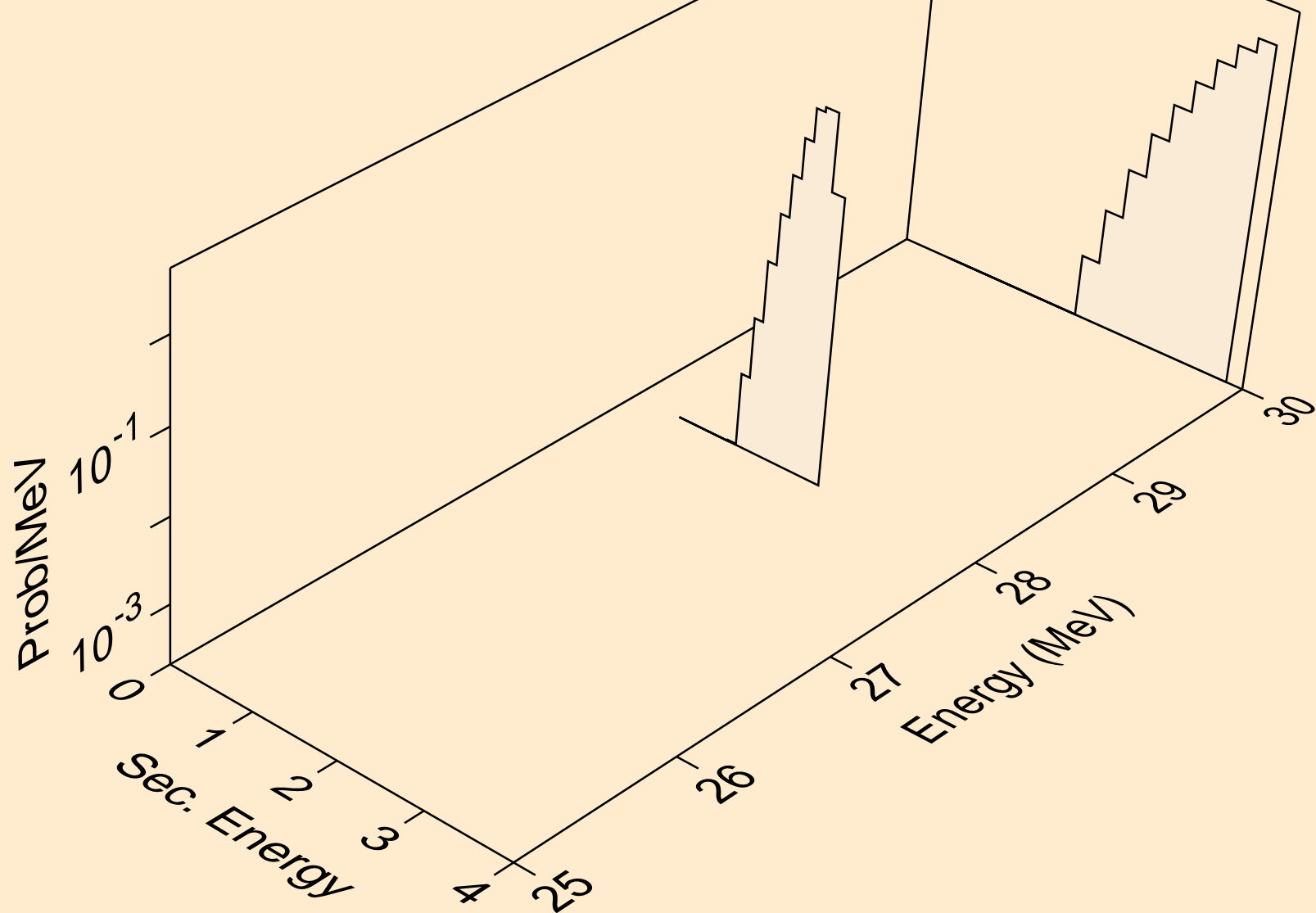

RH094 PHOTON ACER TENDL-2024 LIBRARY; T=0.K
deuterons from (g,d)

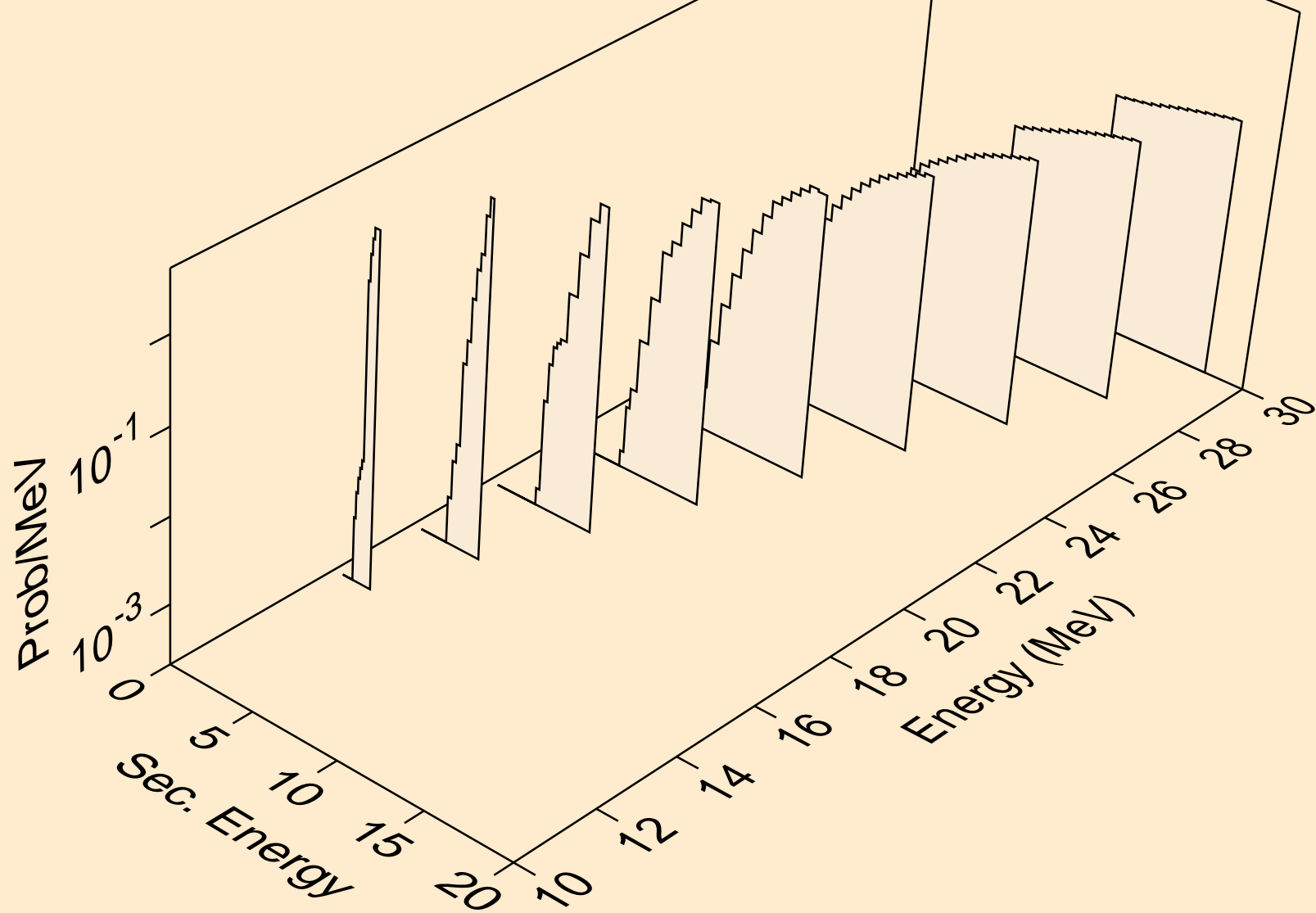

RH094 PHOTON ACER TENDL-2024 LIBRARY; T=0.K
deuterons from (g,pd)

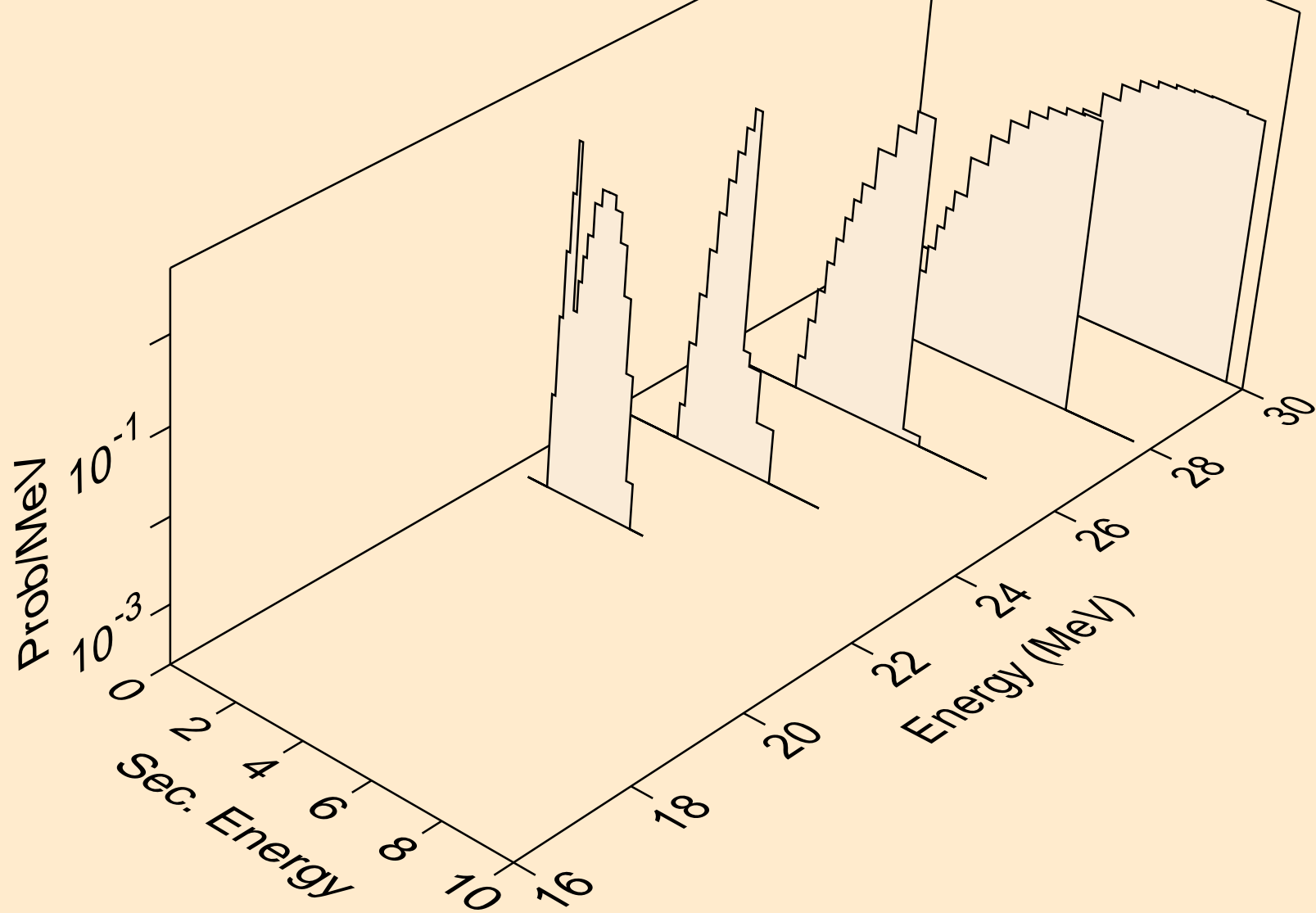

RH094 PHOTON ACER TENDL-2024 LIBRARY; T=0.K
tritons from (g,x)

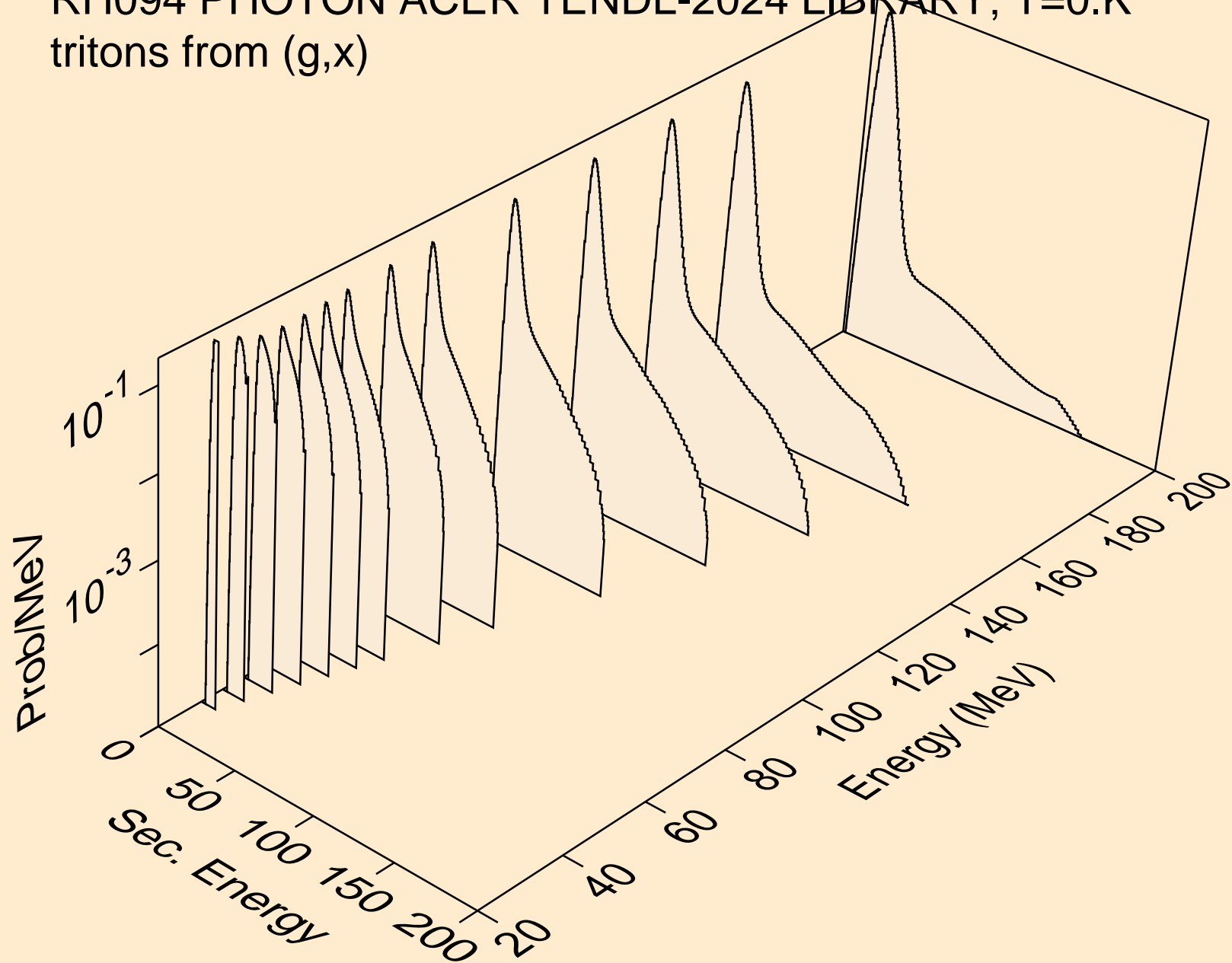

RH094 PHOTON ACER TENDL-2024 LIBRARY; T=0.K
tritons from (g,t)

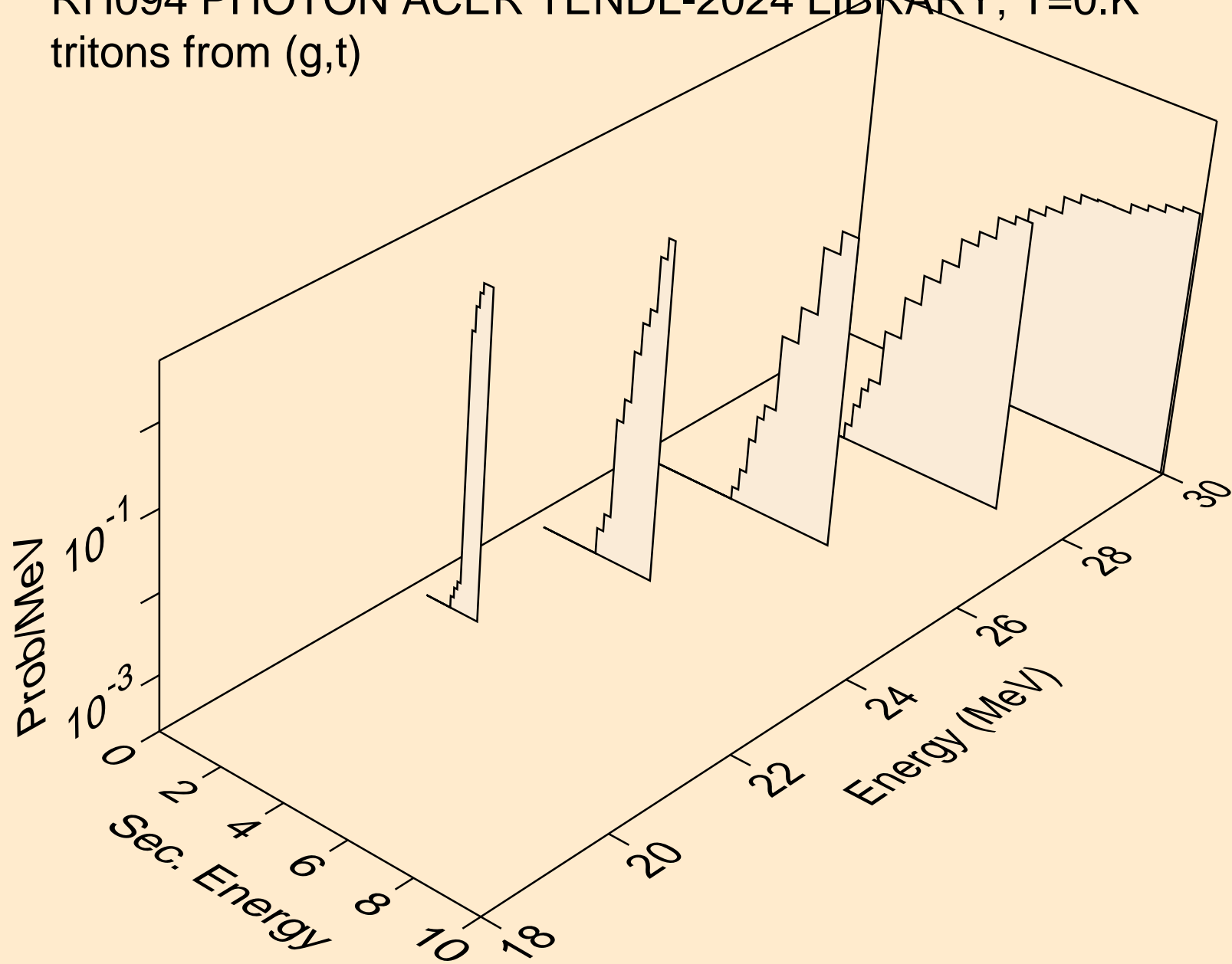

RH094 PHOTON ACER TENDL-2024 LIBRARY; T=0.K
he3s from (g,x)

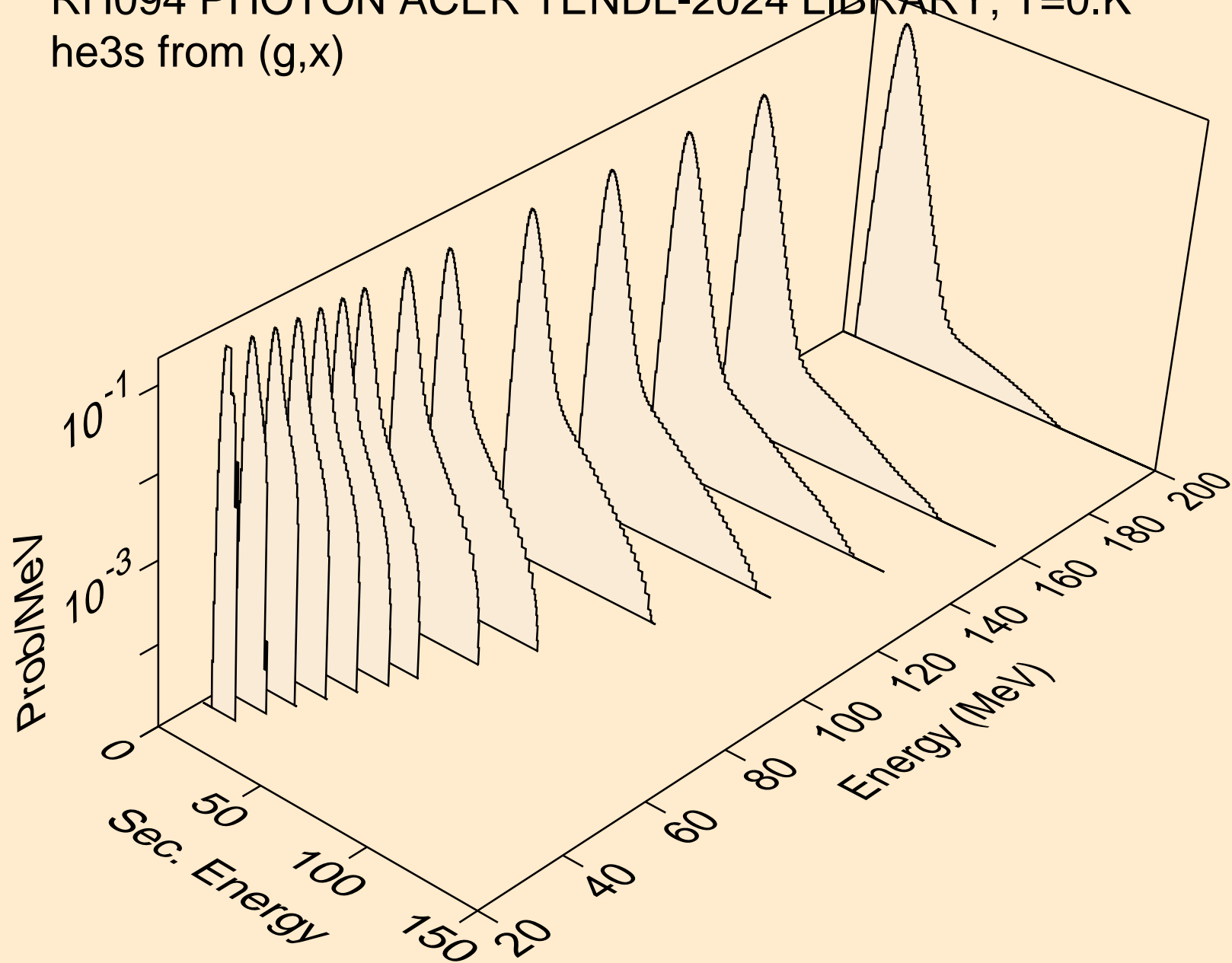

RH094 PHOTON ACER TENDL-2024 LIBRARY; T=0.K
he3s from (g,he3)

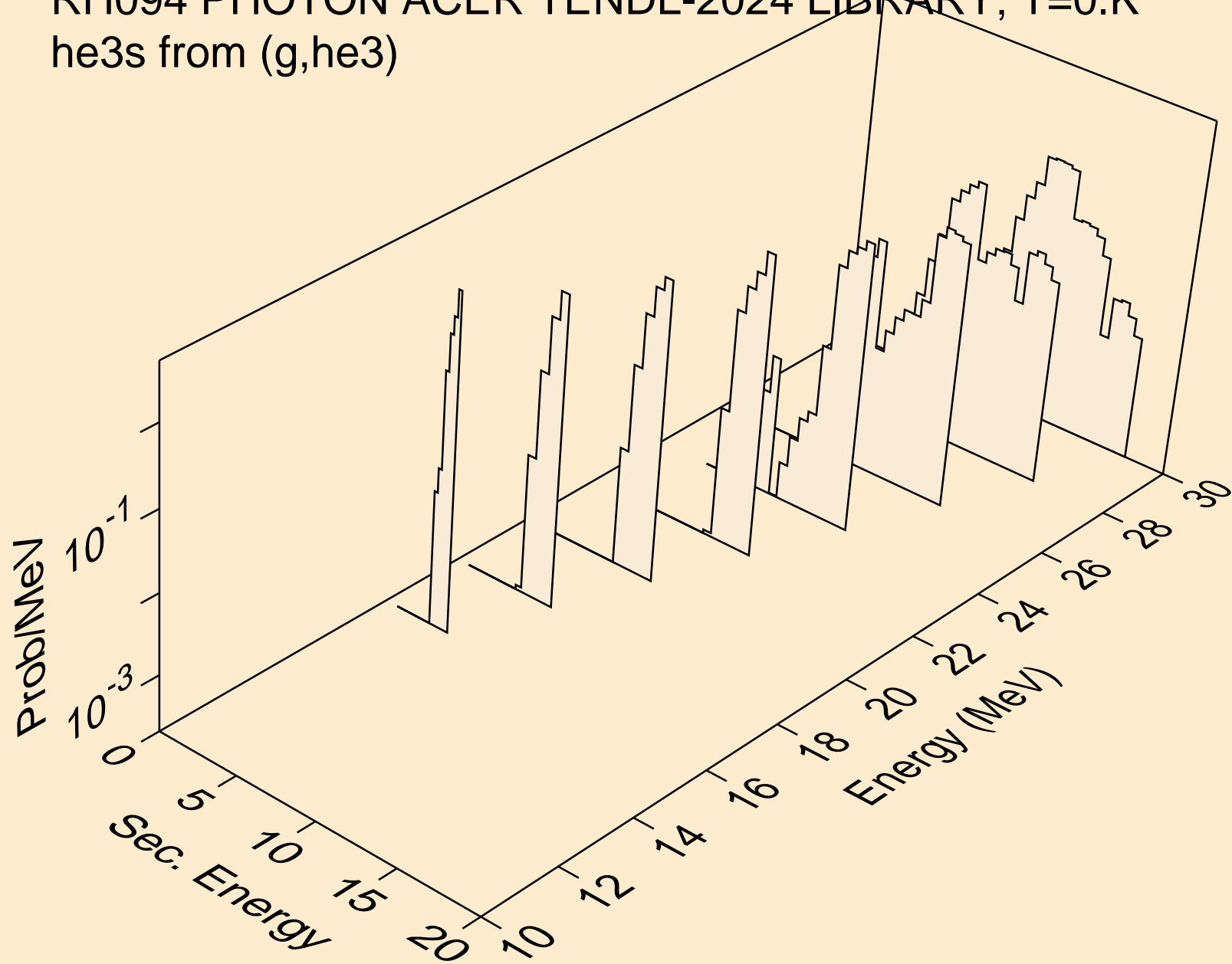

RH094 PHOTON ACER TENDL-2024 LIBRARY; T=0.K
alphas from (g,x)

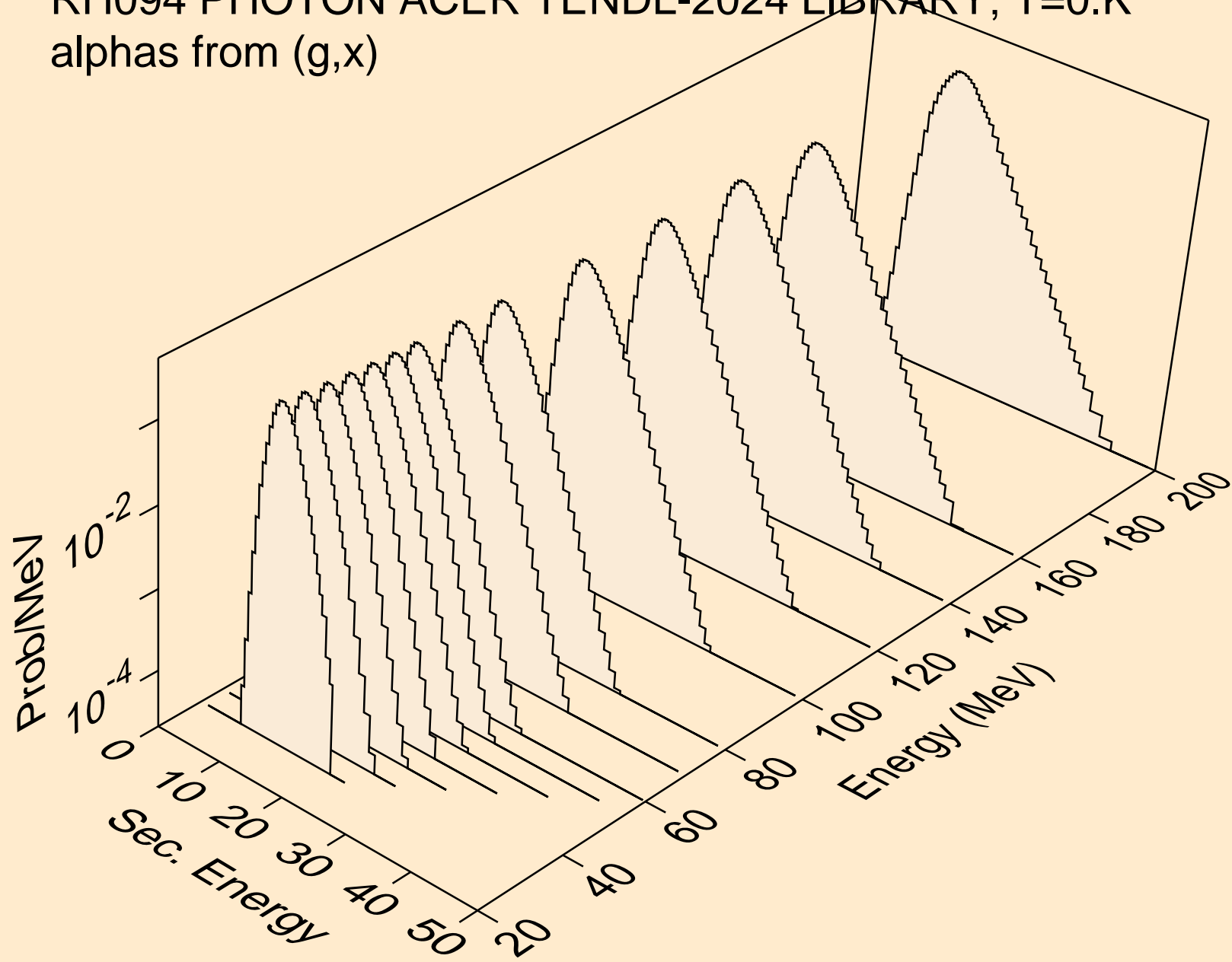

RH094 PHOTON ACER TENDL-2024 LIBRARY; T=0.K
alphas from (g,n*)a

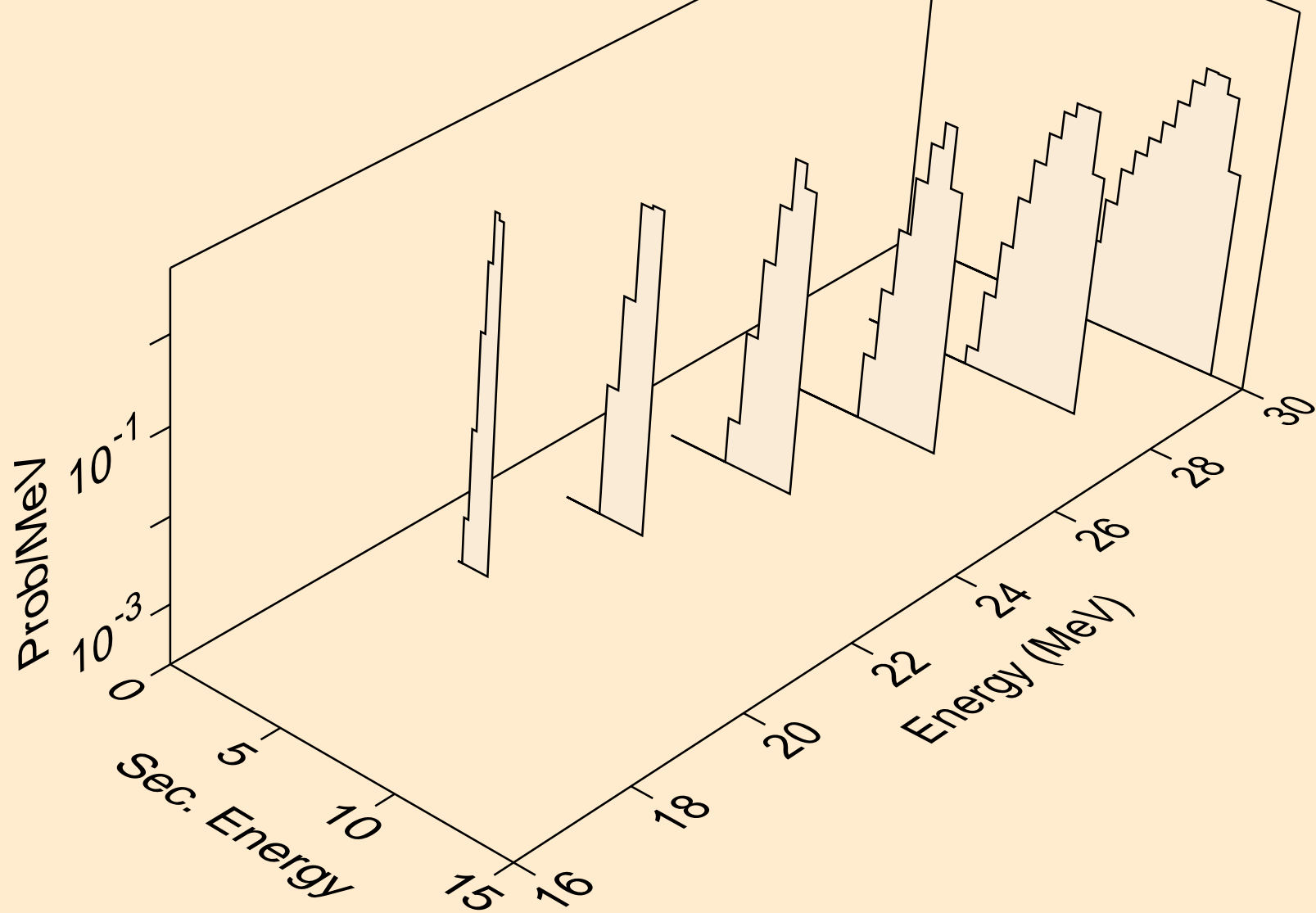

RH094 PHOTON ACER TENDL-2024 LIBRARY; T=0.K
alphas from (g,npa)

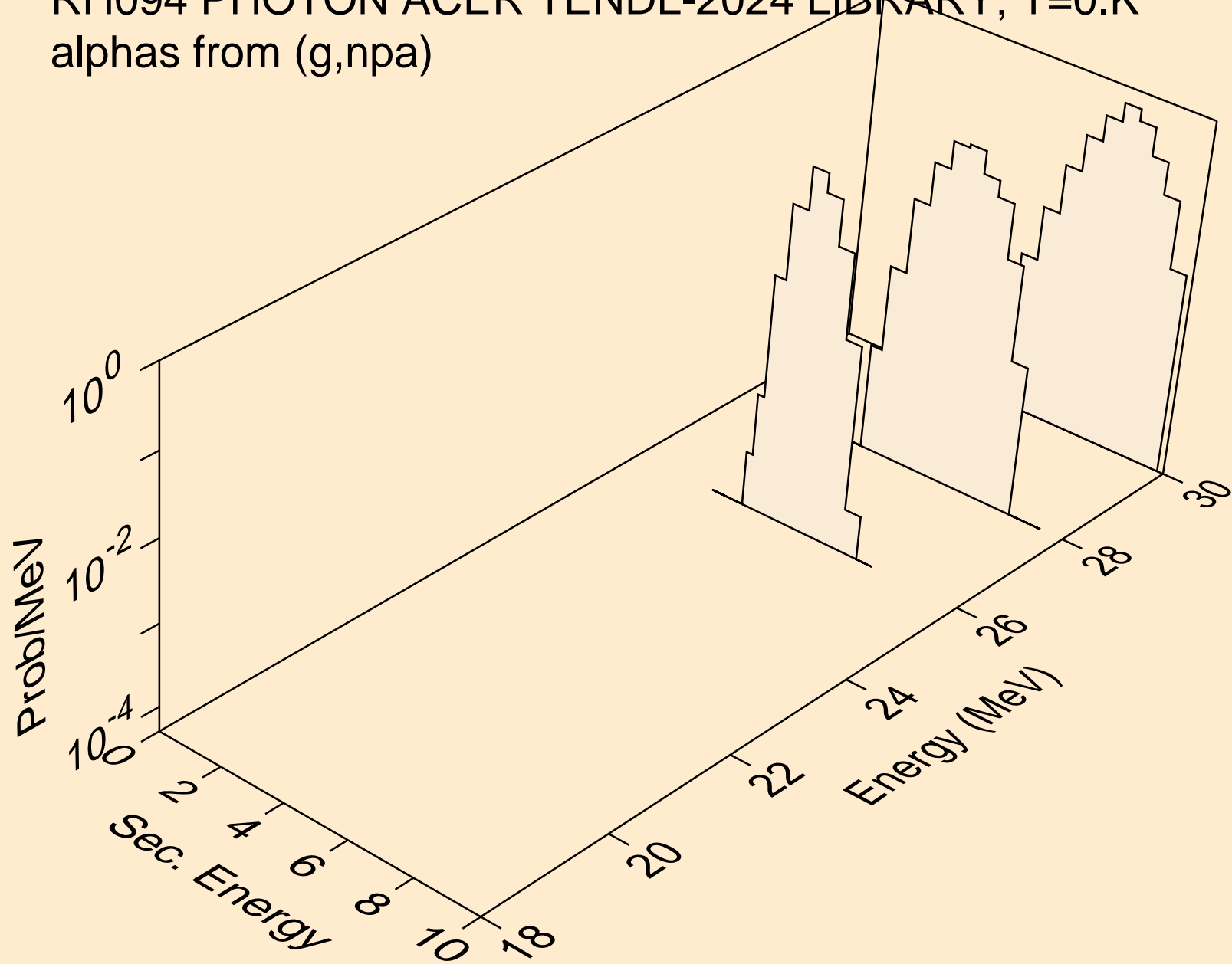

RH094 PHOTON ACER TENDL-2024 LIBRARY; T=0.K
alphas from (g,a)

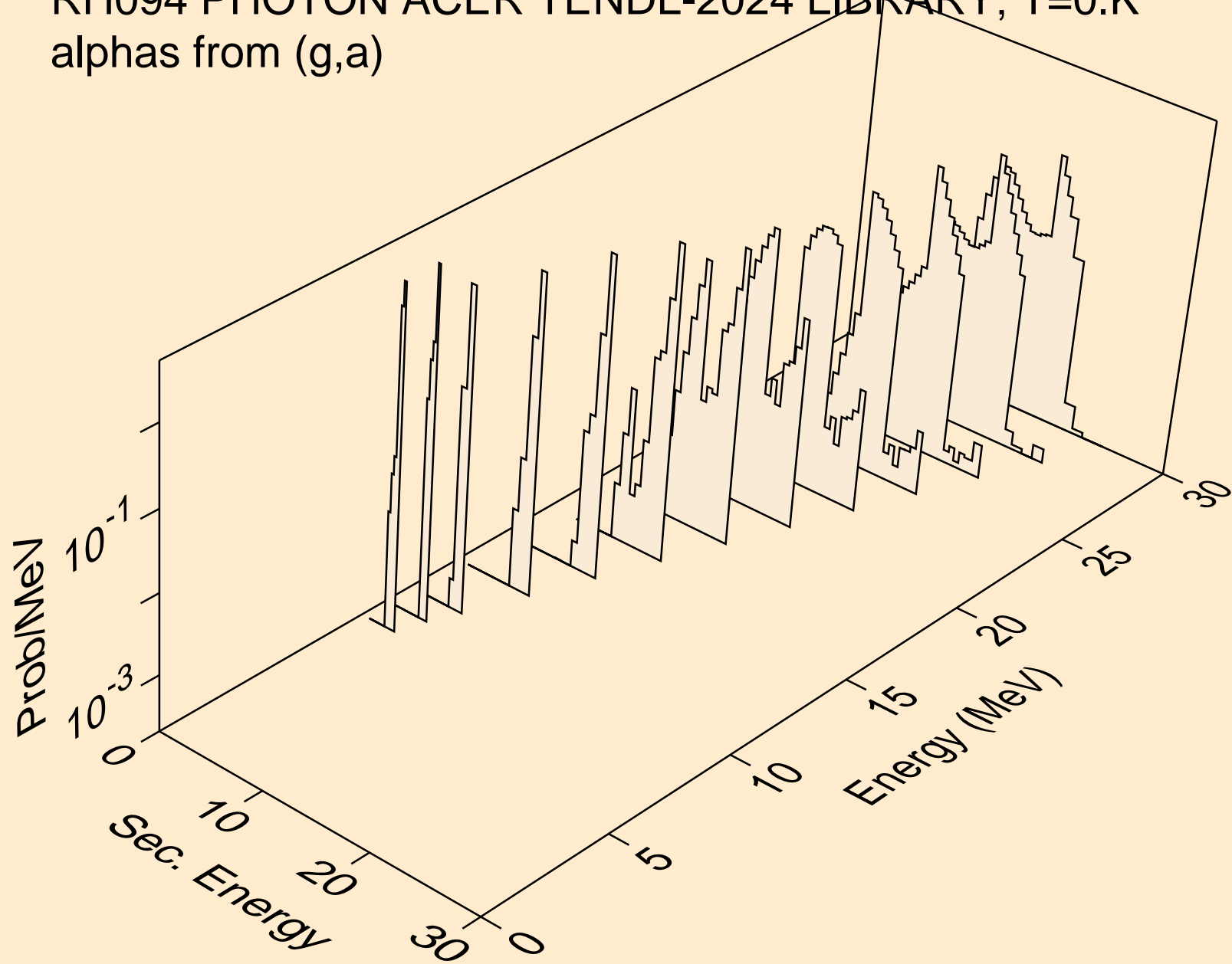

RH094 PHOTON ACER TENDL-2024 LIBRARY; T=0.K
alphas from (g,2a)

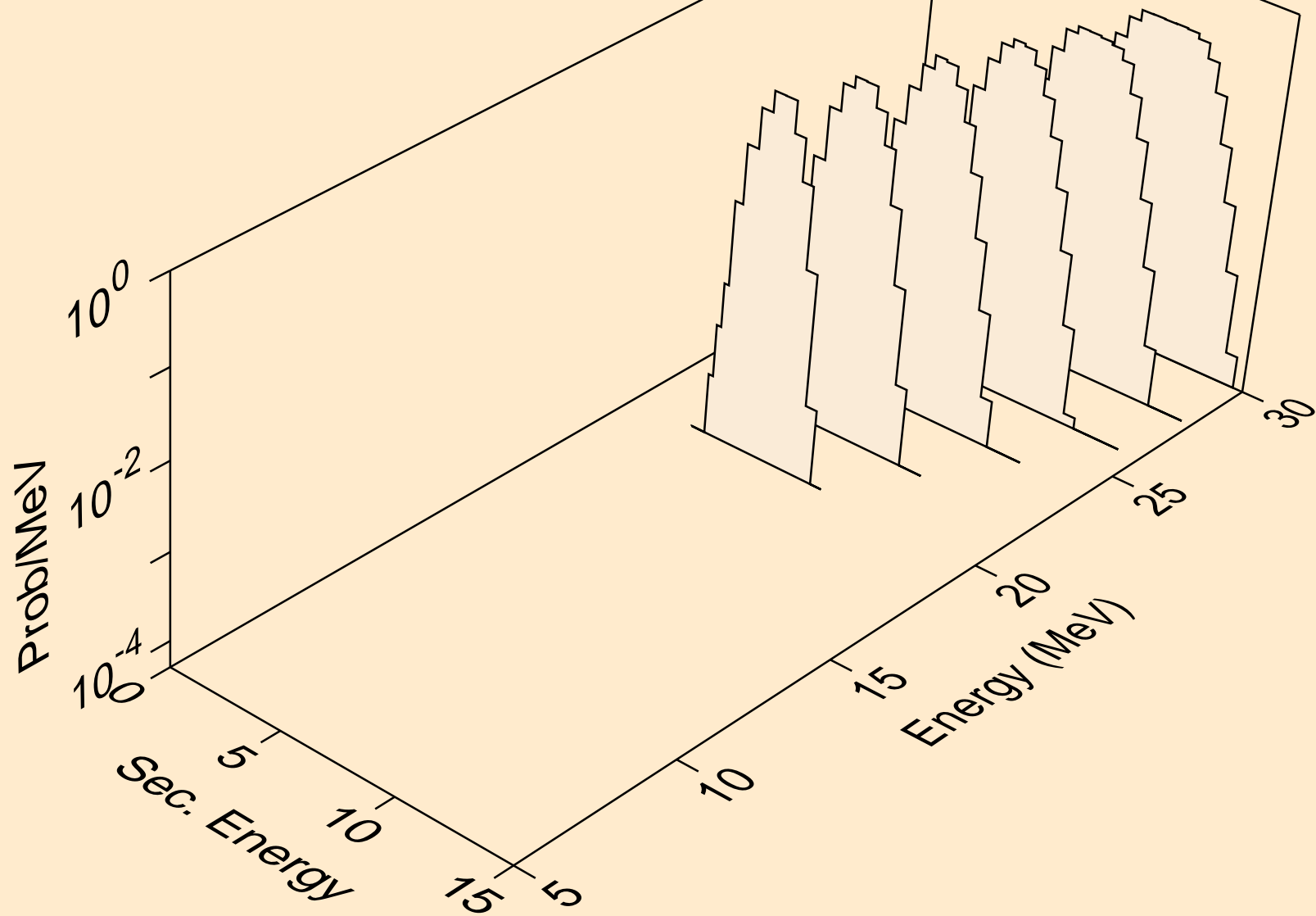

RH094 PHOTON ACER TENDL-2024 LIBRARY; T=0.K
alphas from (g,pa)

