

TA172 PHOTON ACER TENDL-2024 LIBRARY; T=0.K
Principal cross sections

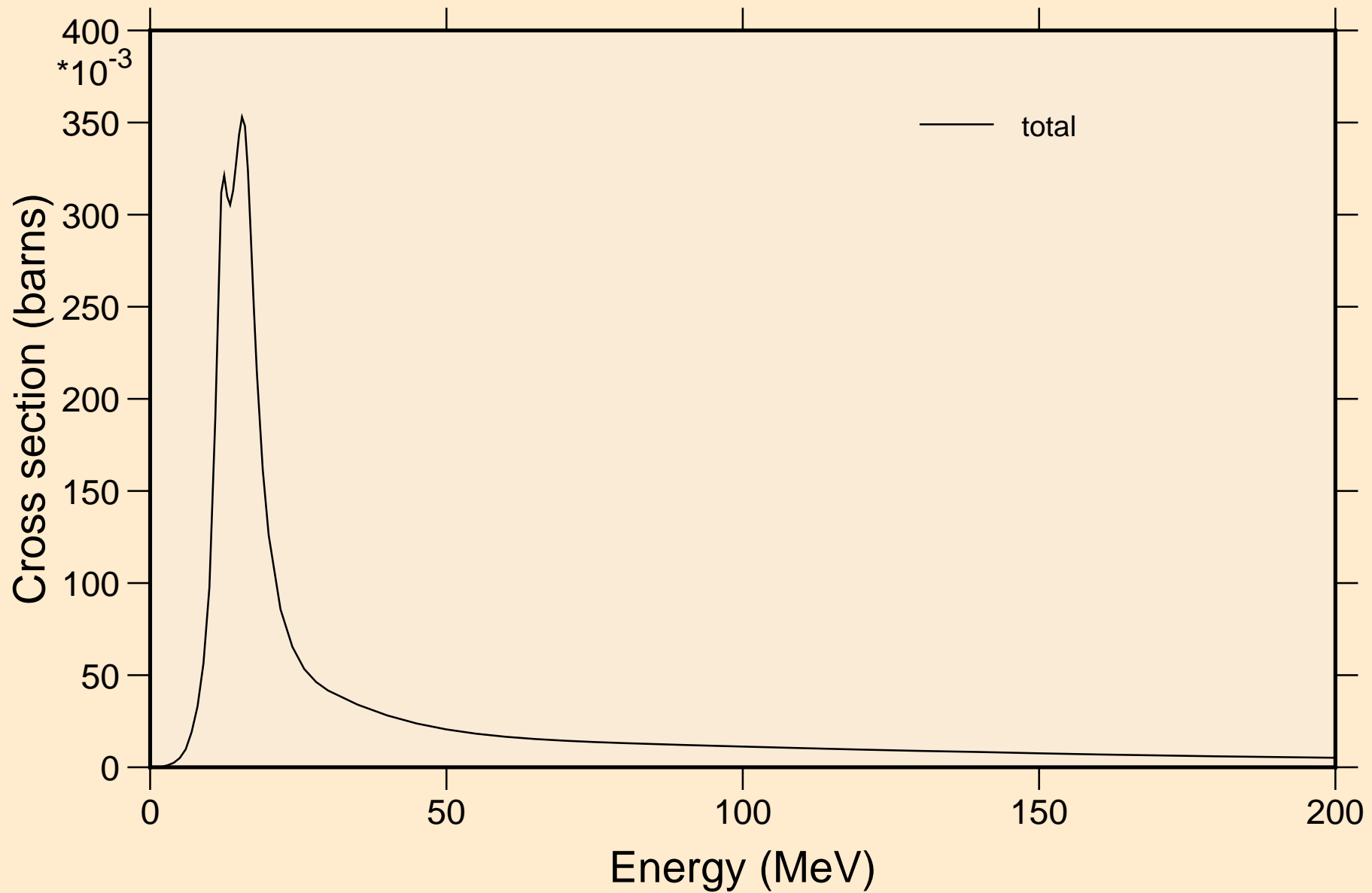

TA172 PHOTON ACER TENDL-2024 LIBRARY; T=0.K

Partial cross sections

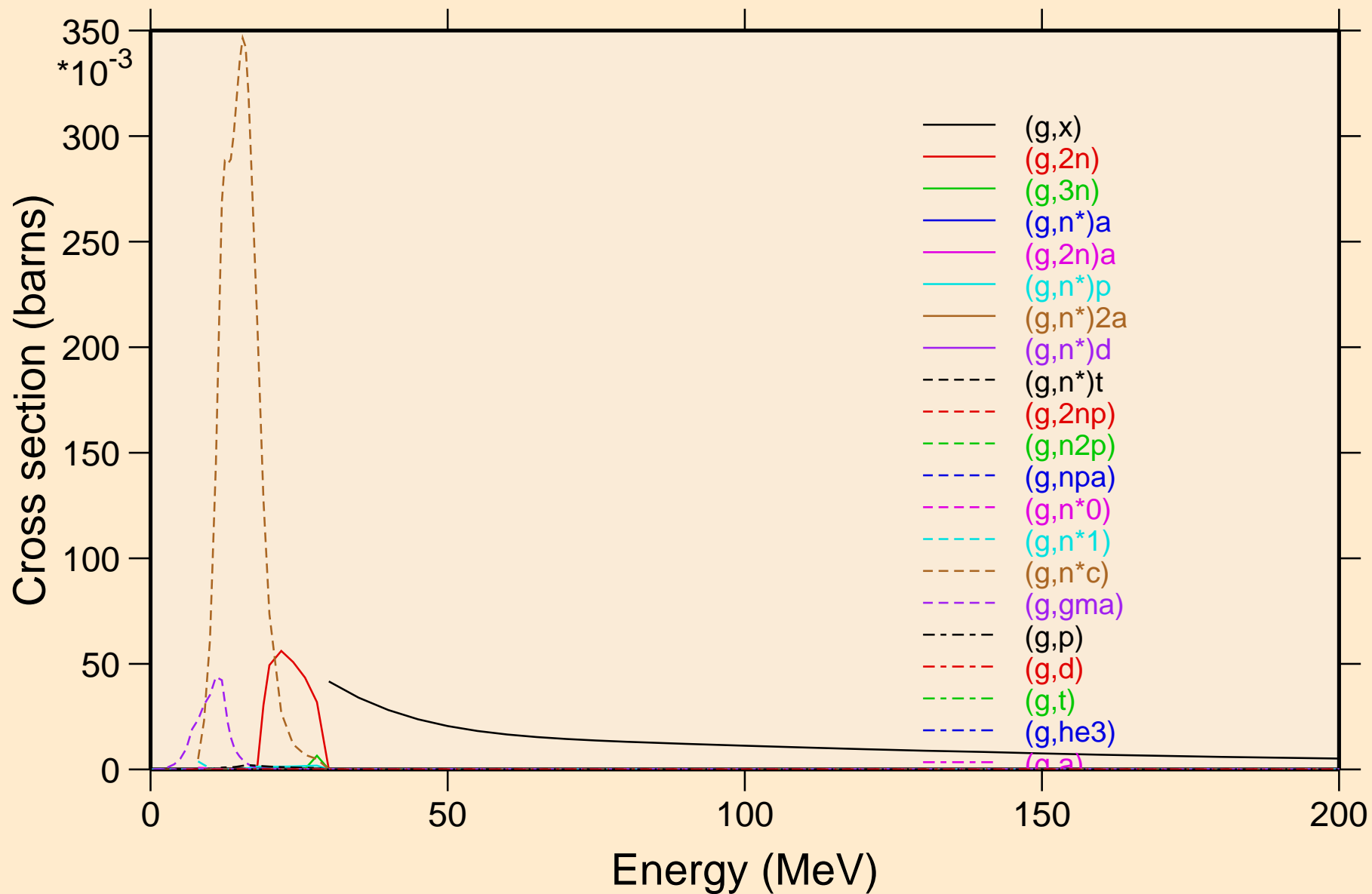

TA172 PHOTON ACER TENDL-2024 LIBRARY; T=0.K

Heating

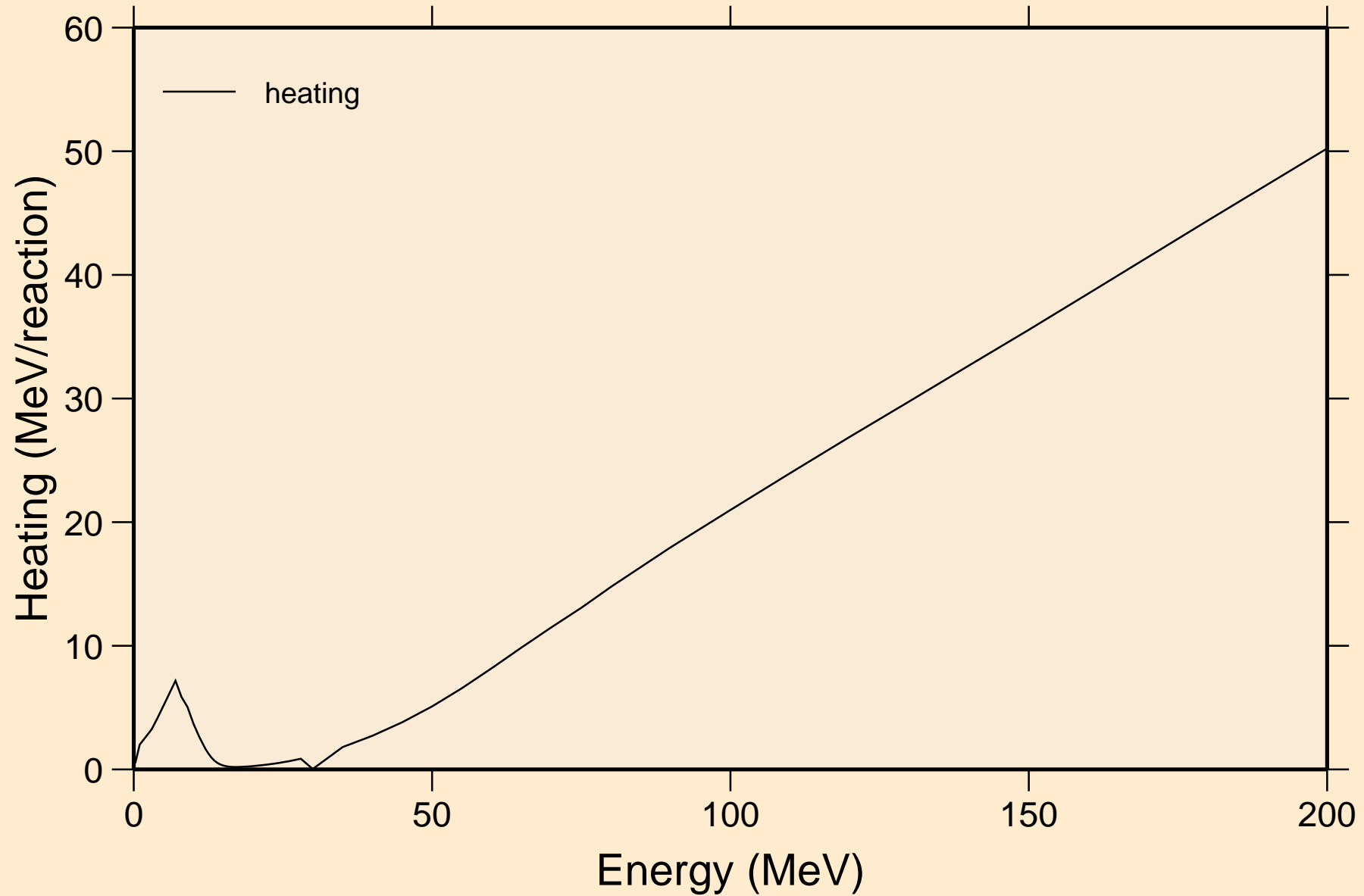

TA172 PHOTON ACER TENDL-2024 LIBRARY; T=0.K

Particle heating contributions

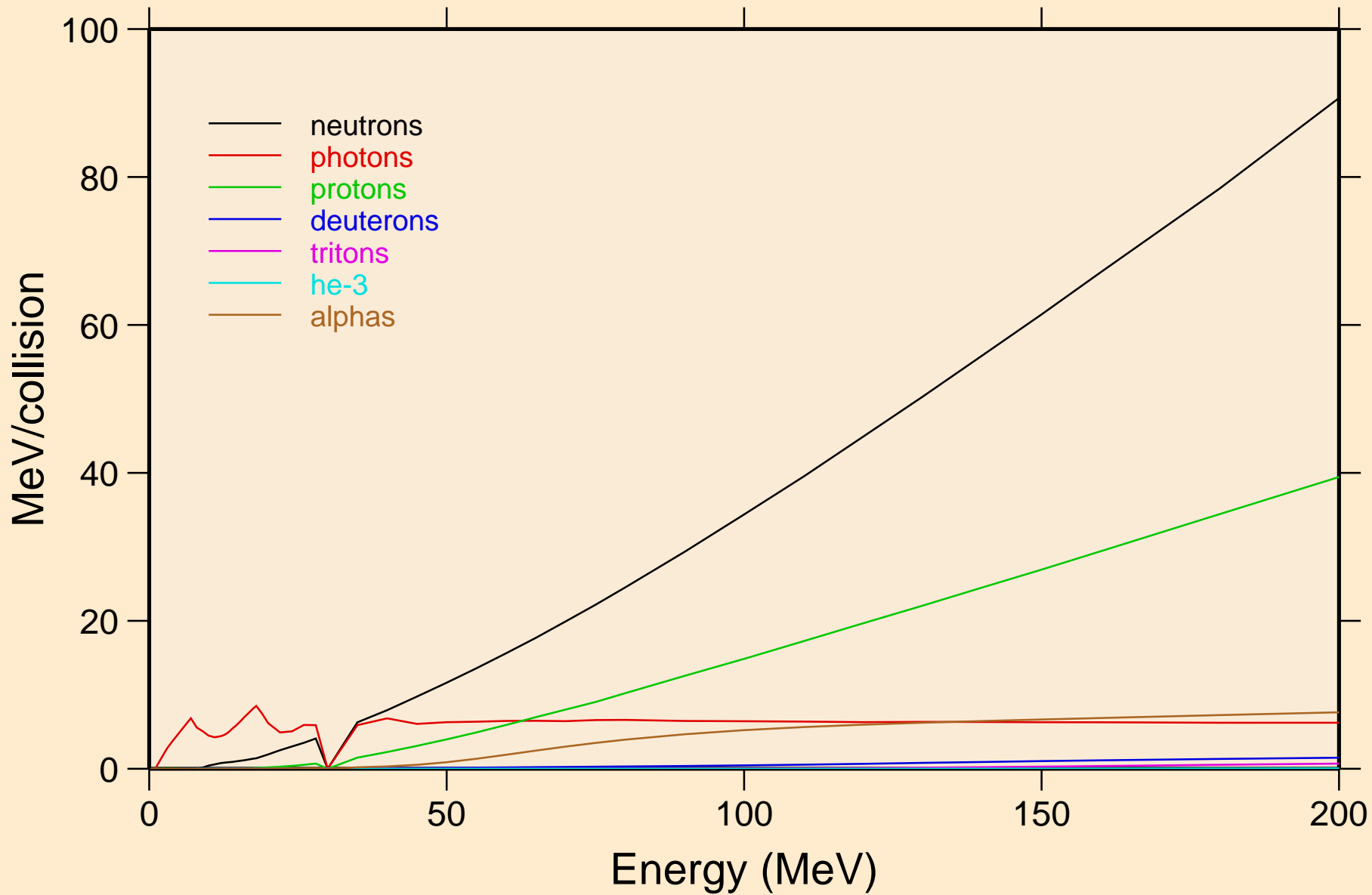

TA172 PHOTON ACER TENDL-2024 LIBRARY; T=0.K

Particle production cross sections

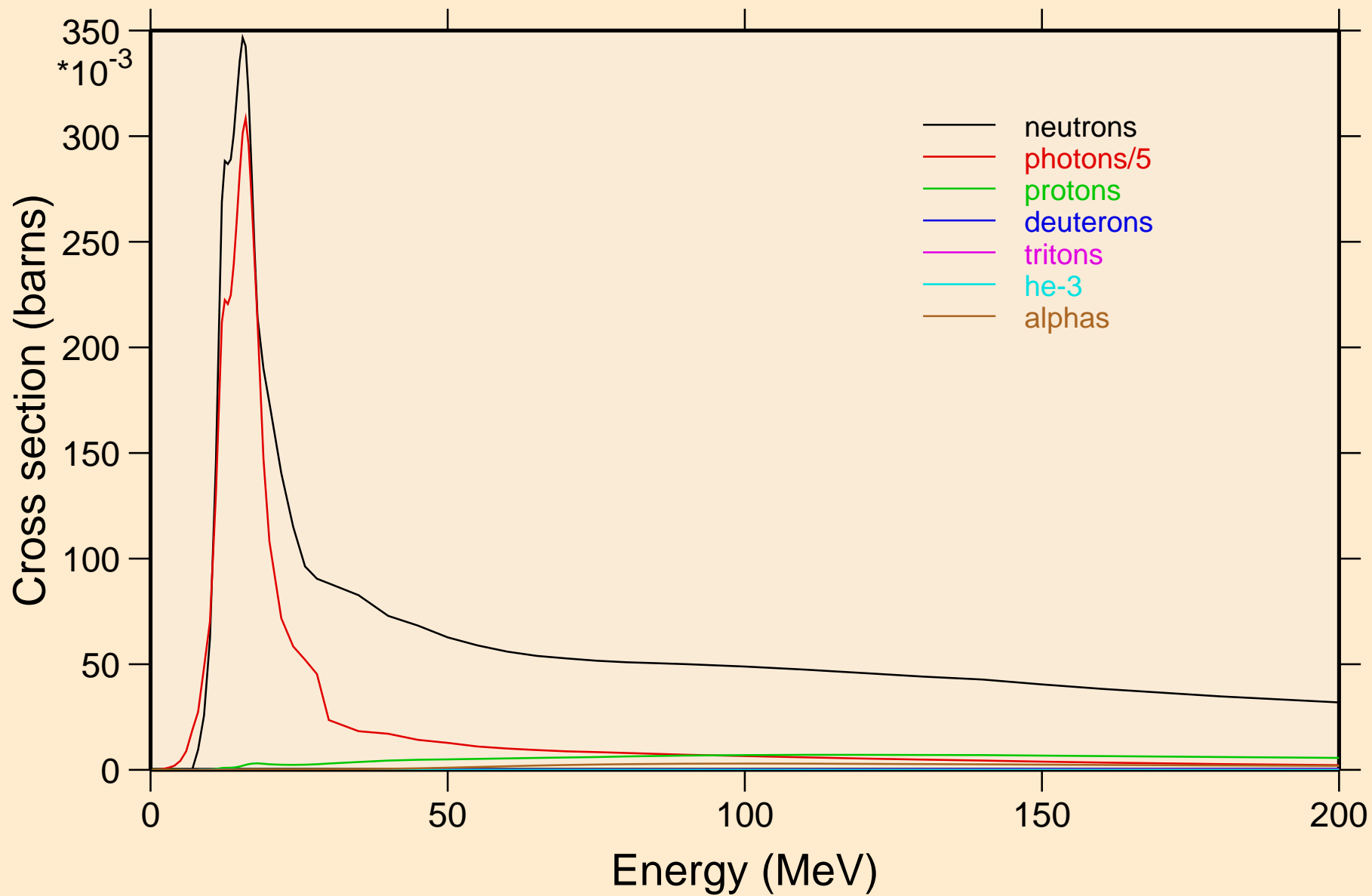

TA172 PHOTON ACER TENDL-2024 LIBRARY; T=0.K
neutrons from (g,x)

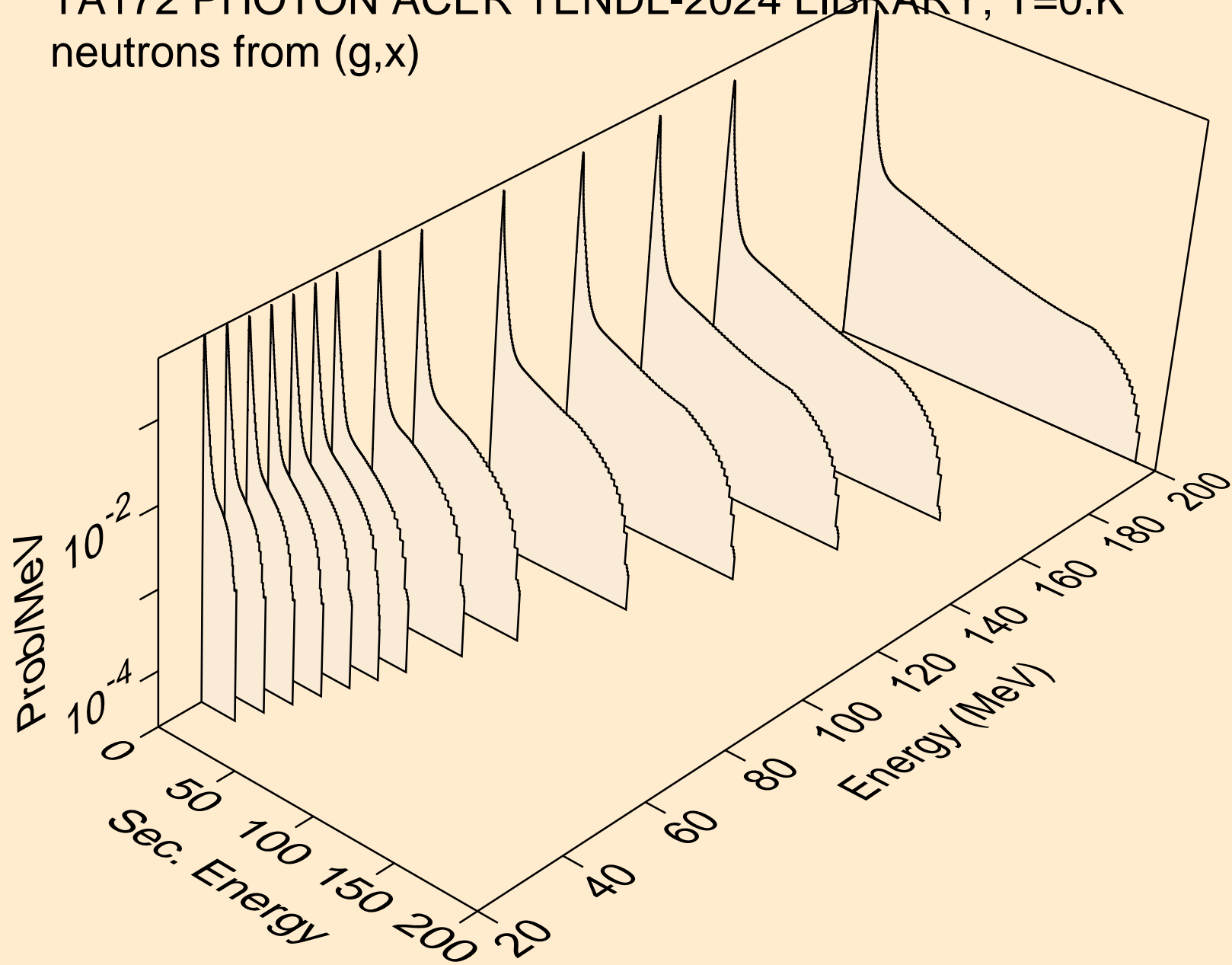

TA172 PHOTON ACER TENDL-2024 LIBRARY; T=0.K
neutrons from (g,2n)

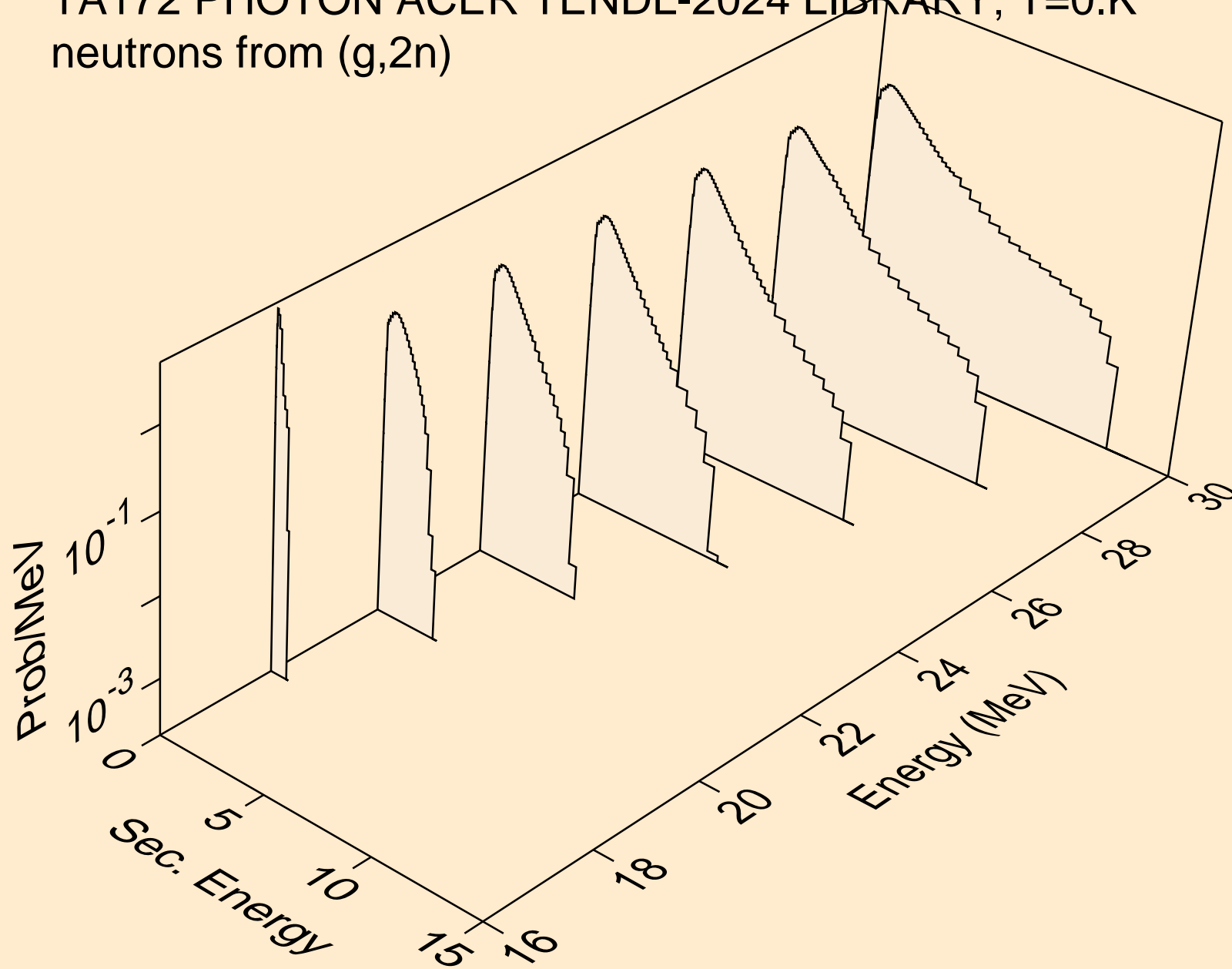

TA172 PHOTON ACER TENDL-2024 LIBRARY; T=0.K
neutrons from (g,3n)

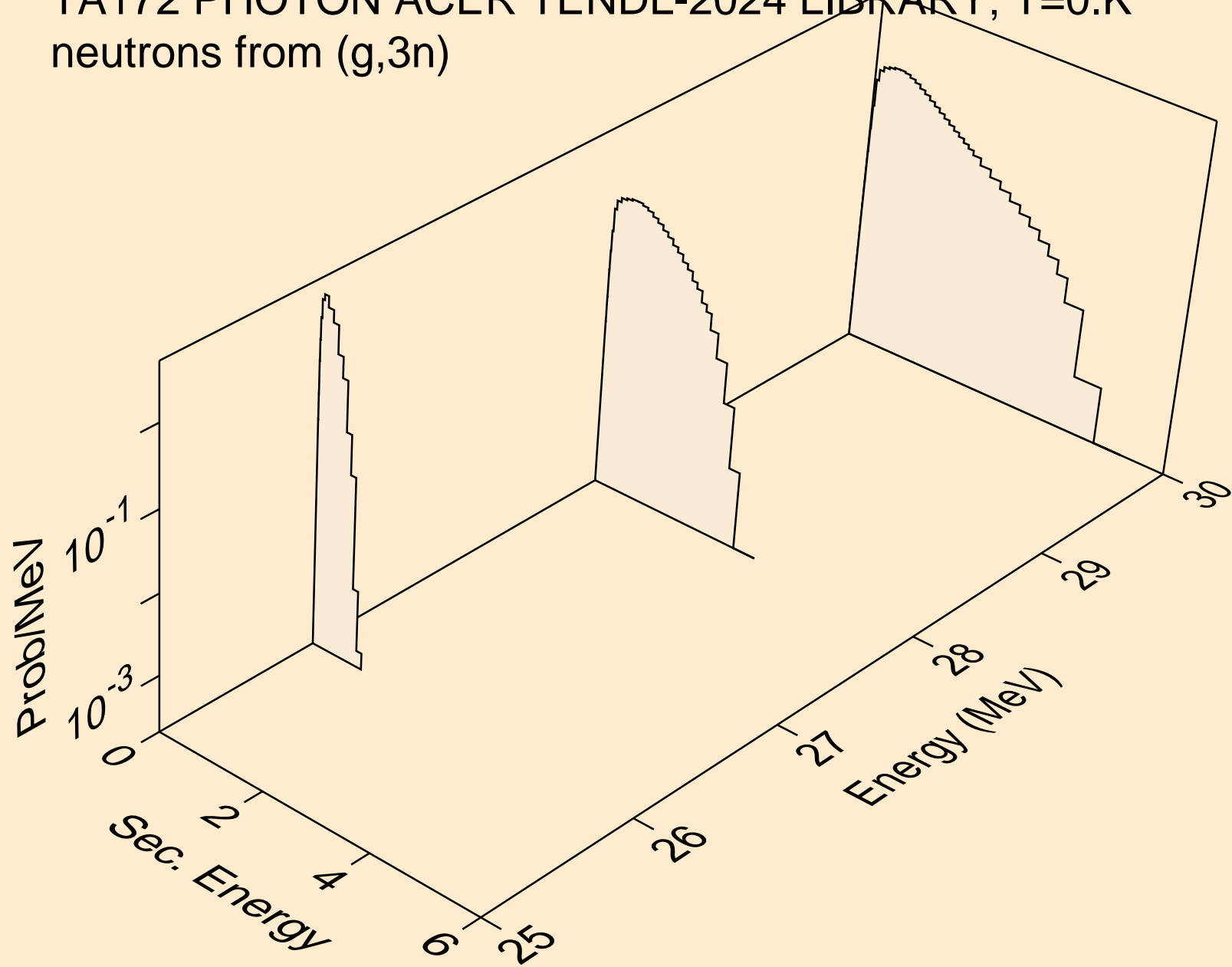

TA172 PHOTON ACER TENDL-2024 LIBRARY; T=0.K
neutrons from (g,n*)a

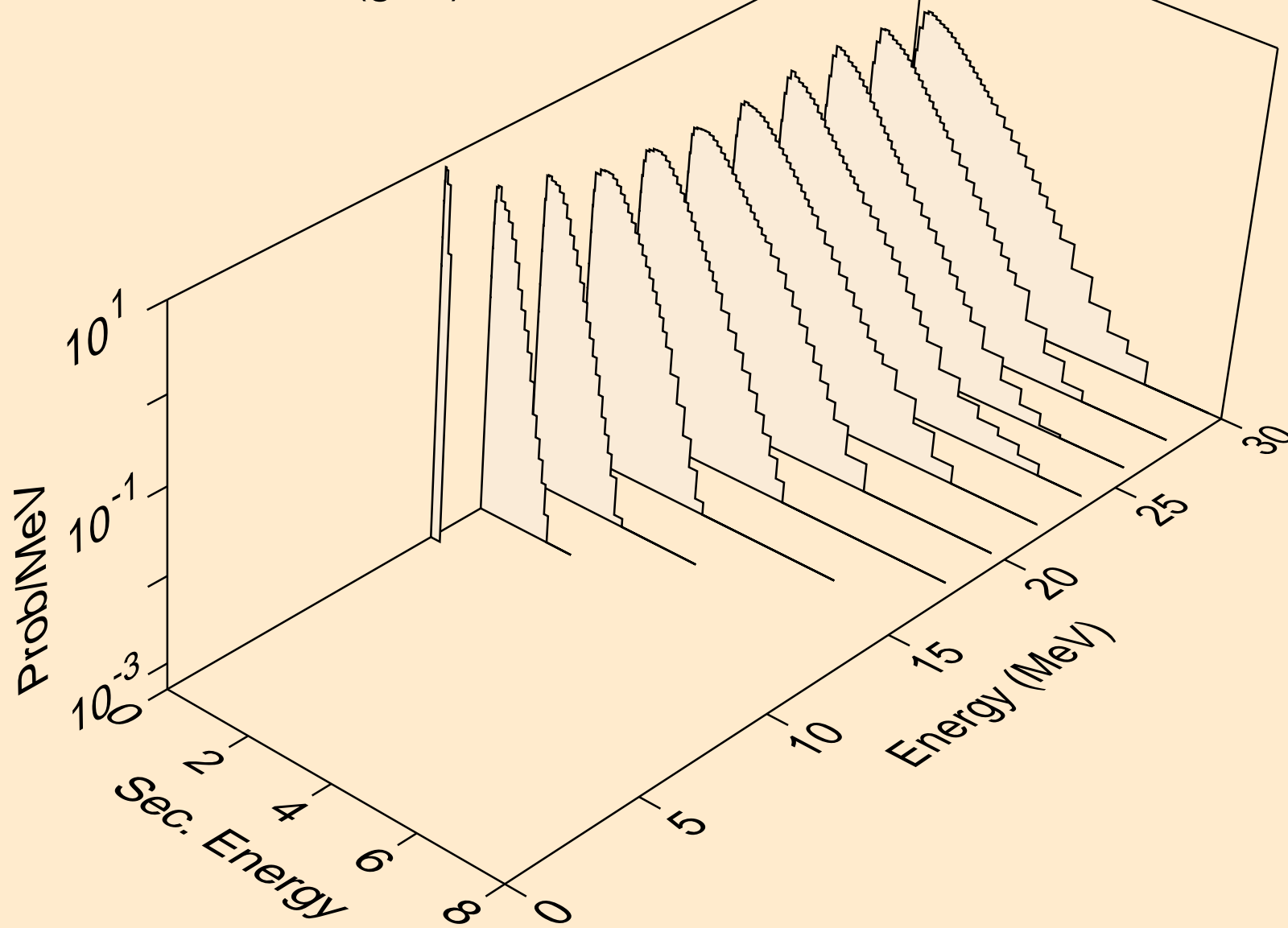

TA172 PHOTON ACER TENDL-2024 LIBRARY; T=0.K
neutrons from (g,2n)a

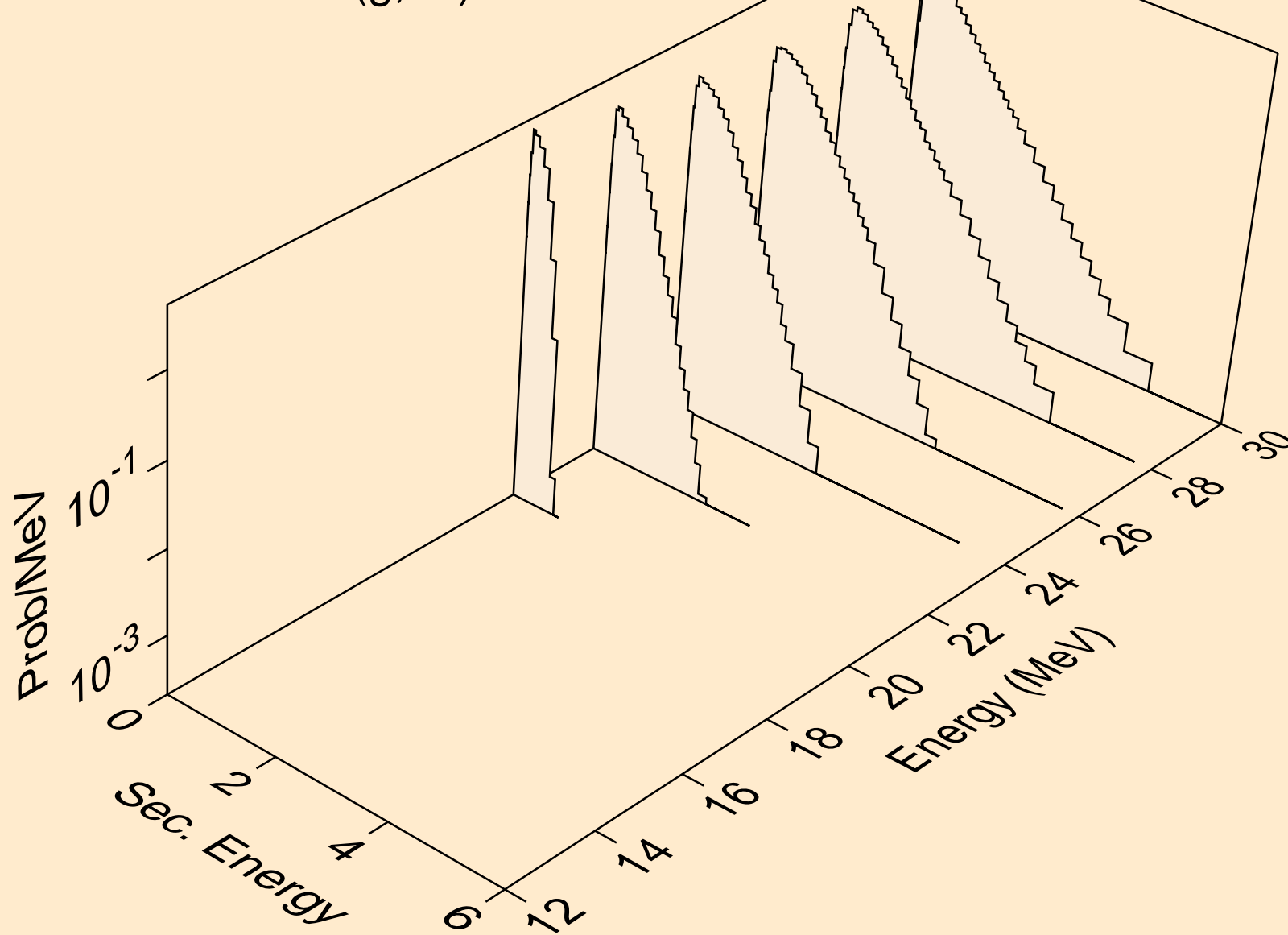

TA172 PHOTON ACER TENDL-2024 LIBRARY; T=0.K
neutrons from (g,n*)p

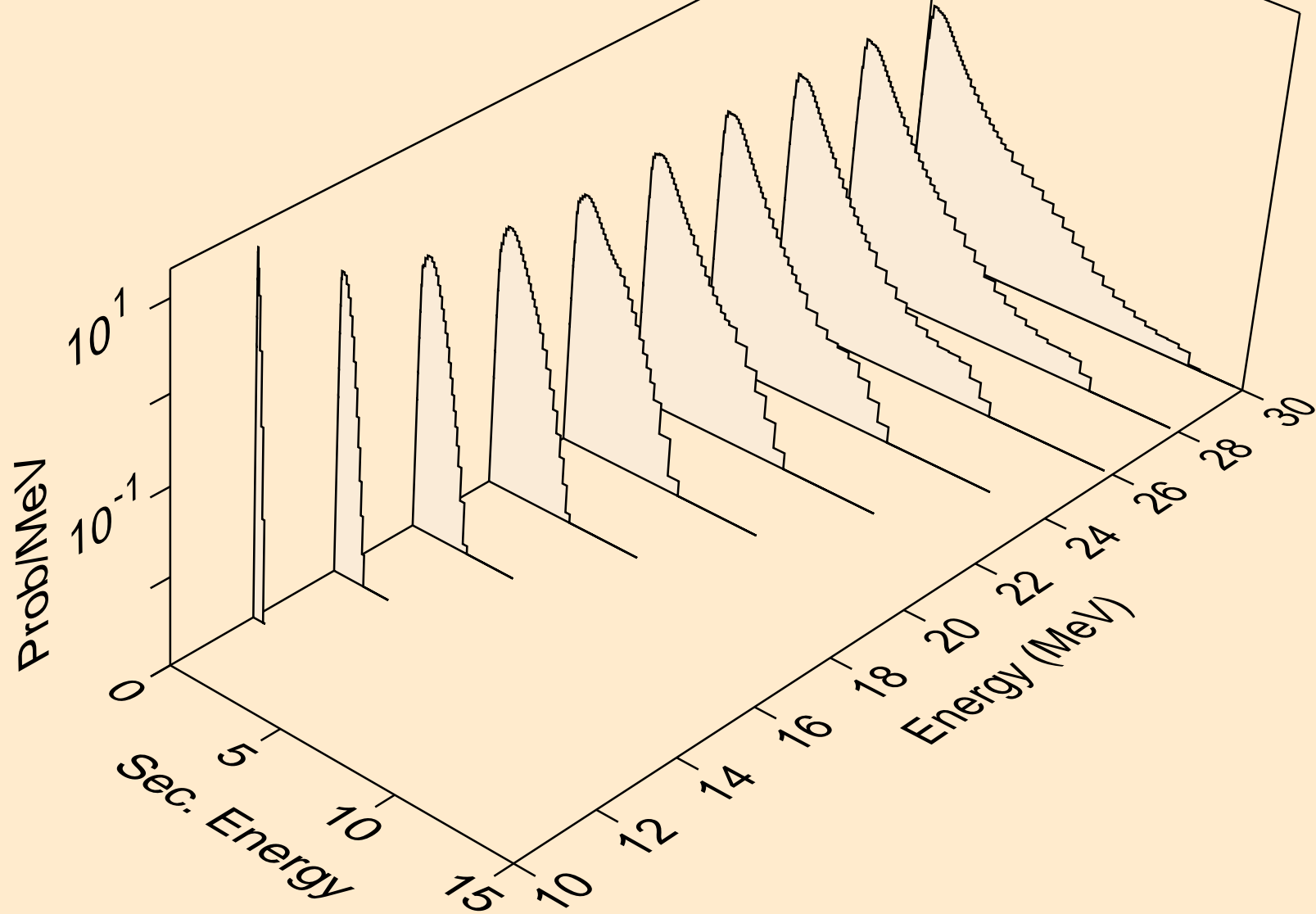

TA172 PHOTON ACER TENDL-2024 LIBRARY; T=0.K
neutrons from (g,n*)2a

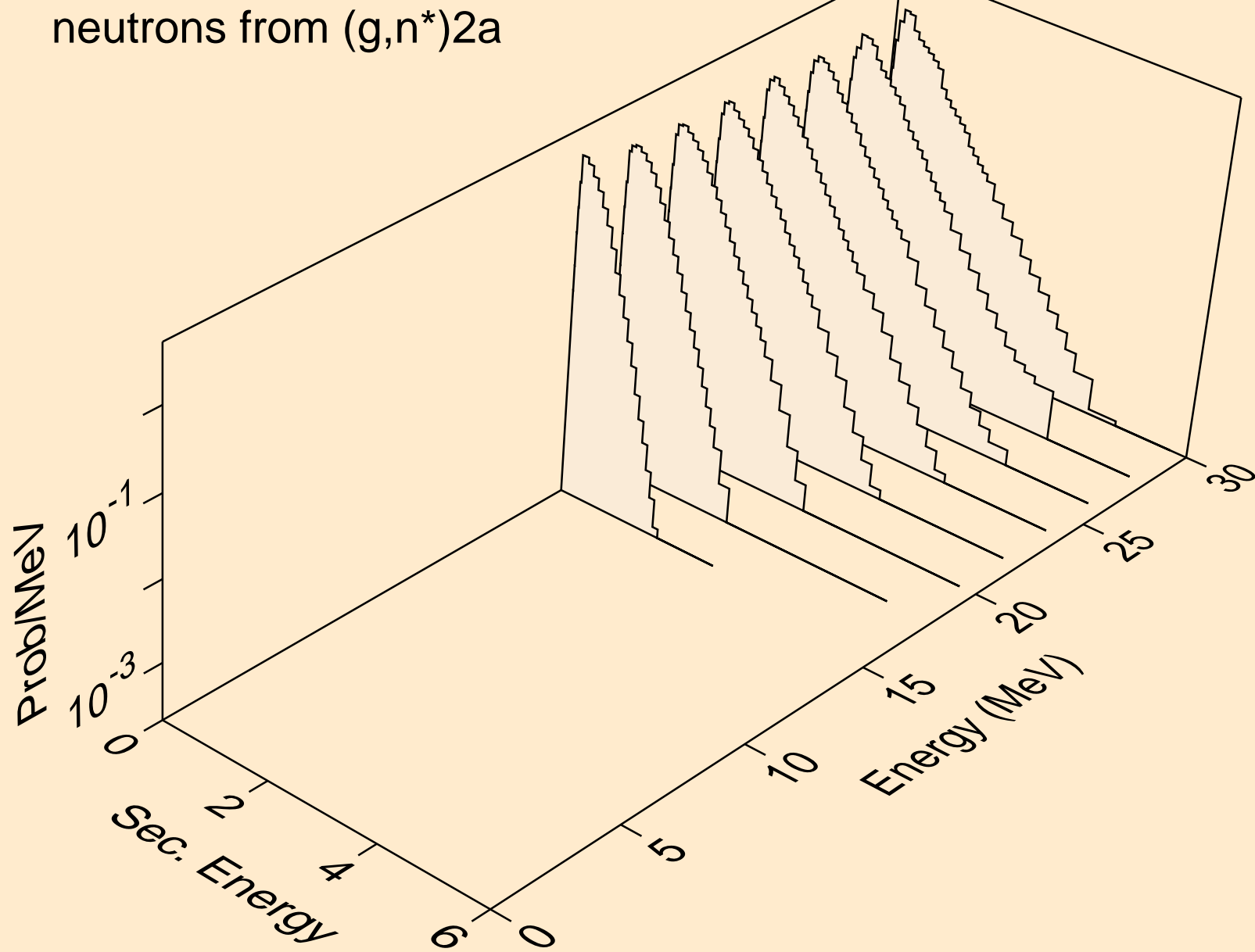

TA172 PHOTON ACER TENDL-2024 LIBRARY; T=0.K
neutrons from (g,n*)d

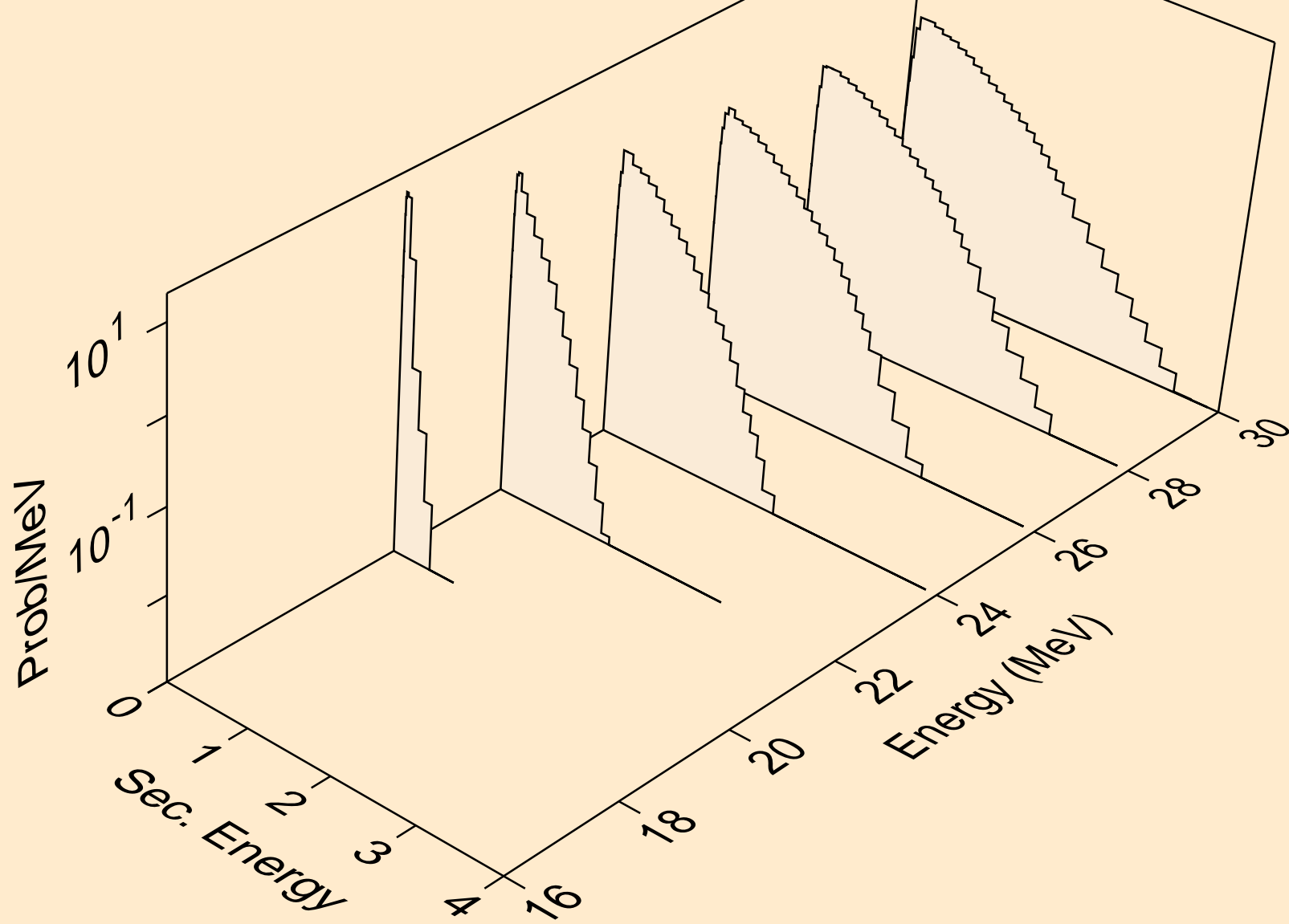

TA172 PHOTON ACER TENDL-2024 LIBRARY; T=0.K
neutrons from (g,n*)t

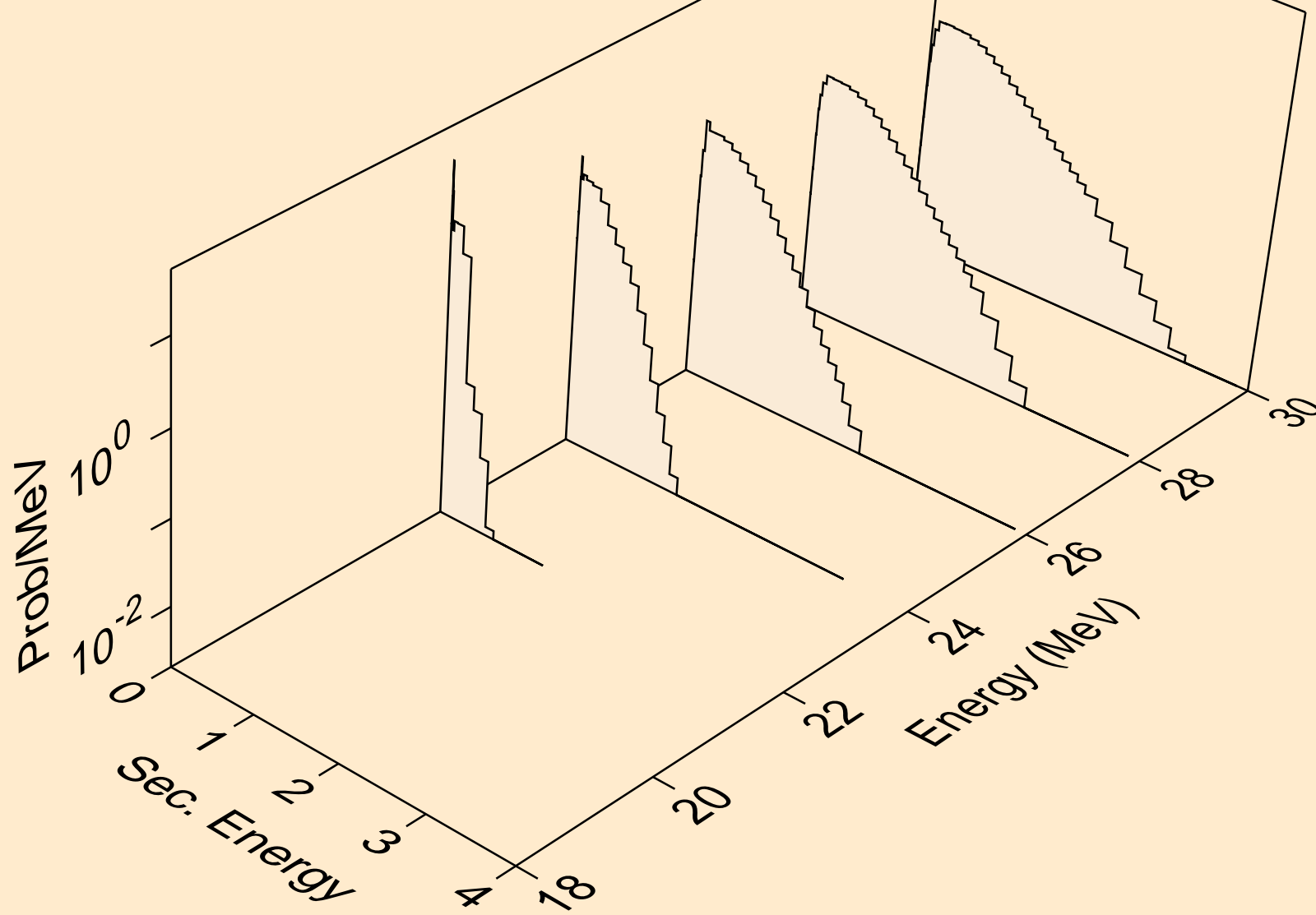

TA172 PHOTON ACER TENDL-2024 LIBRARY; T=0.K
neutrons from (g,2np)

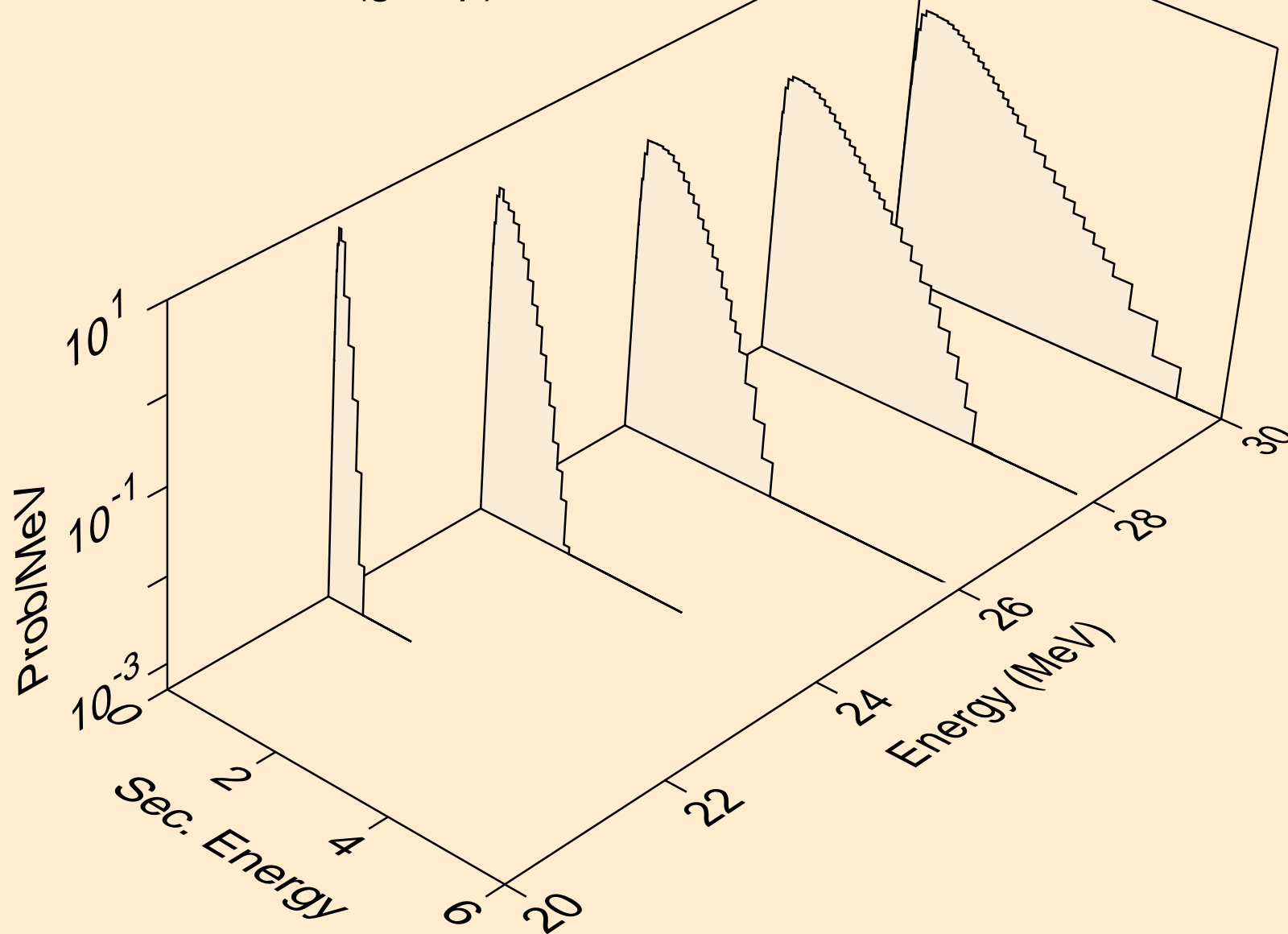

TA172 PHOTON ACER TENDL-2024 LIBRARY; T=0.K
neutrons from (g,n2p)

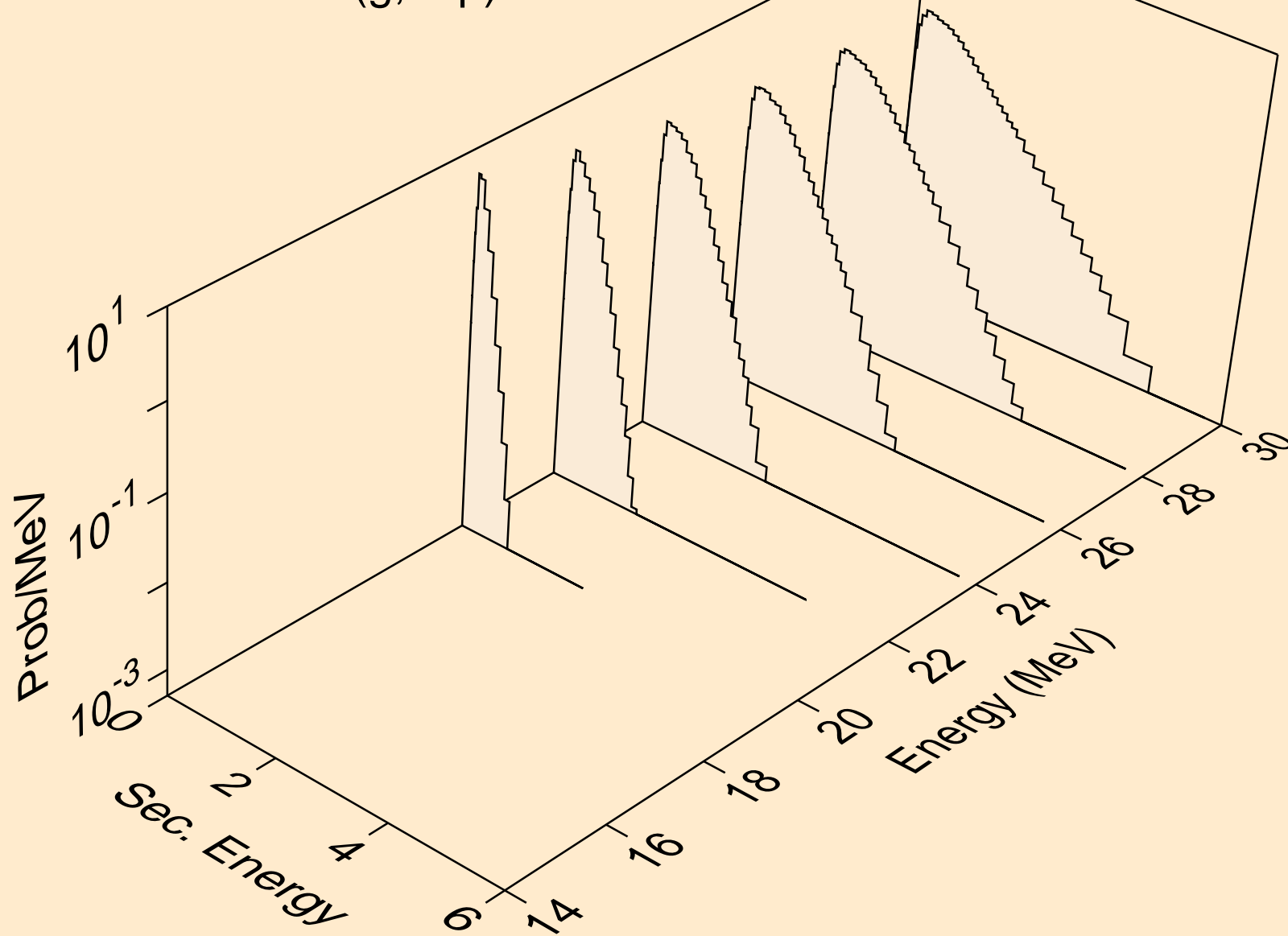

TA172 PHOTON ACER TENDL-2024 LIBRARY; T=0.K
neutrons from (g,npa)

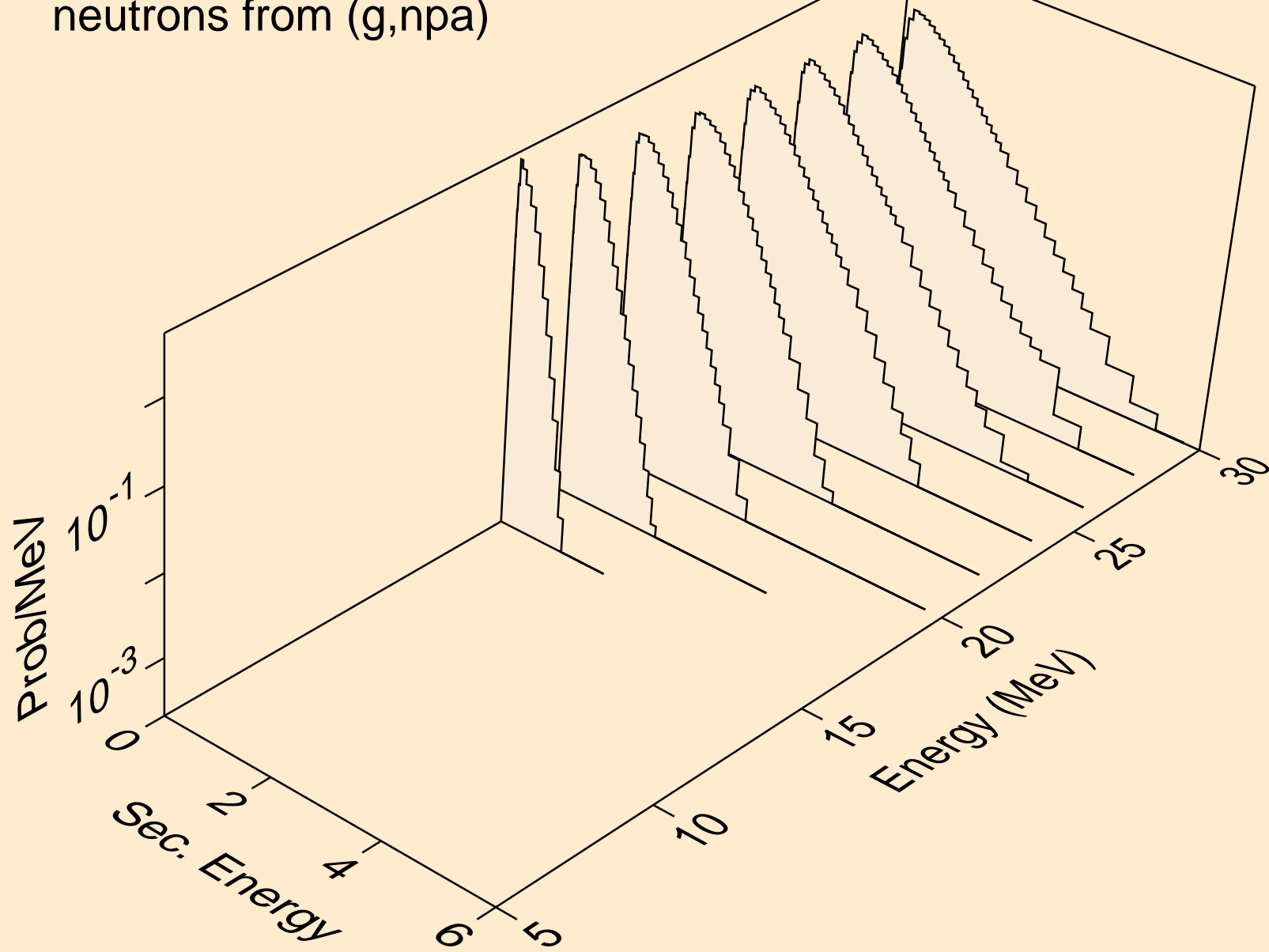

TA172 PHOTON ACER TENDL-2024 LIBRARY; T=0.K
angular distribution for (g,n*0) neutron

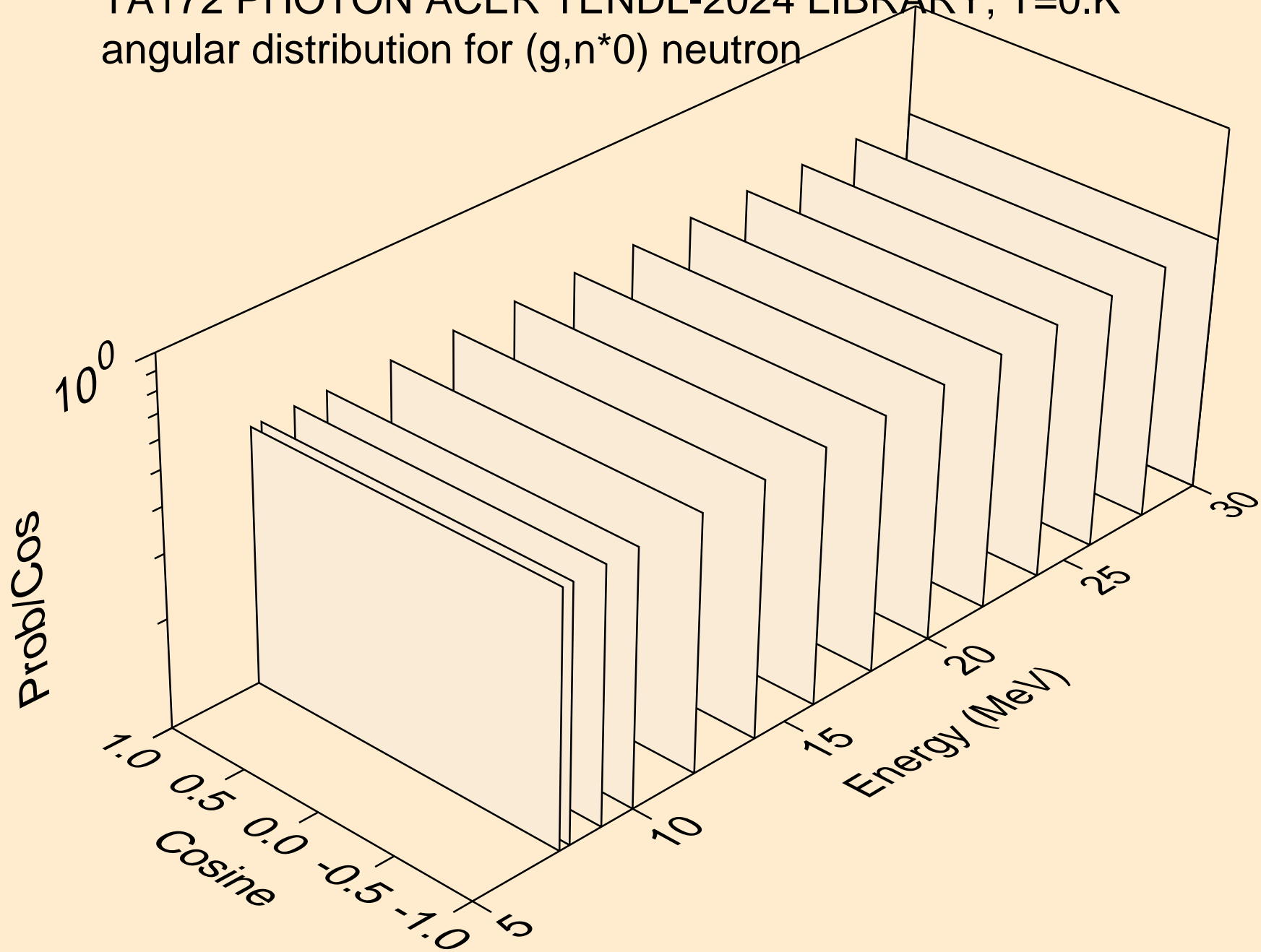

TA172 PHOTON ACER TENDL-2024 LIBRARY; T=0.K
angular distribution for (g,n*1) neutron

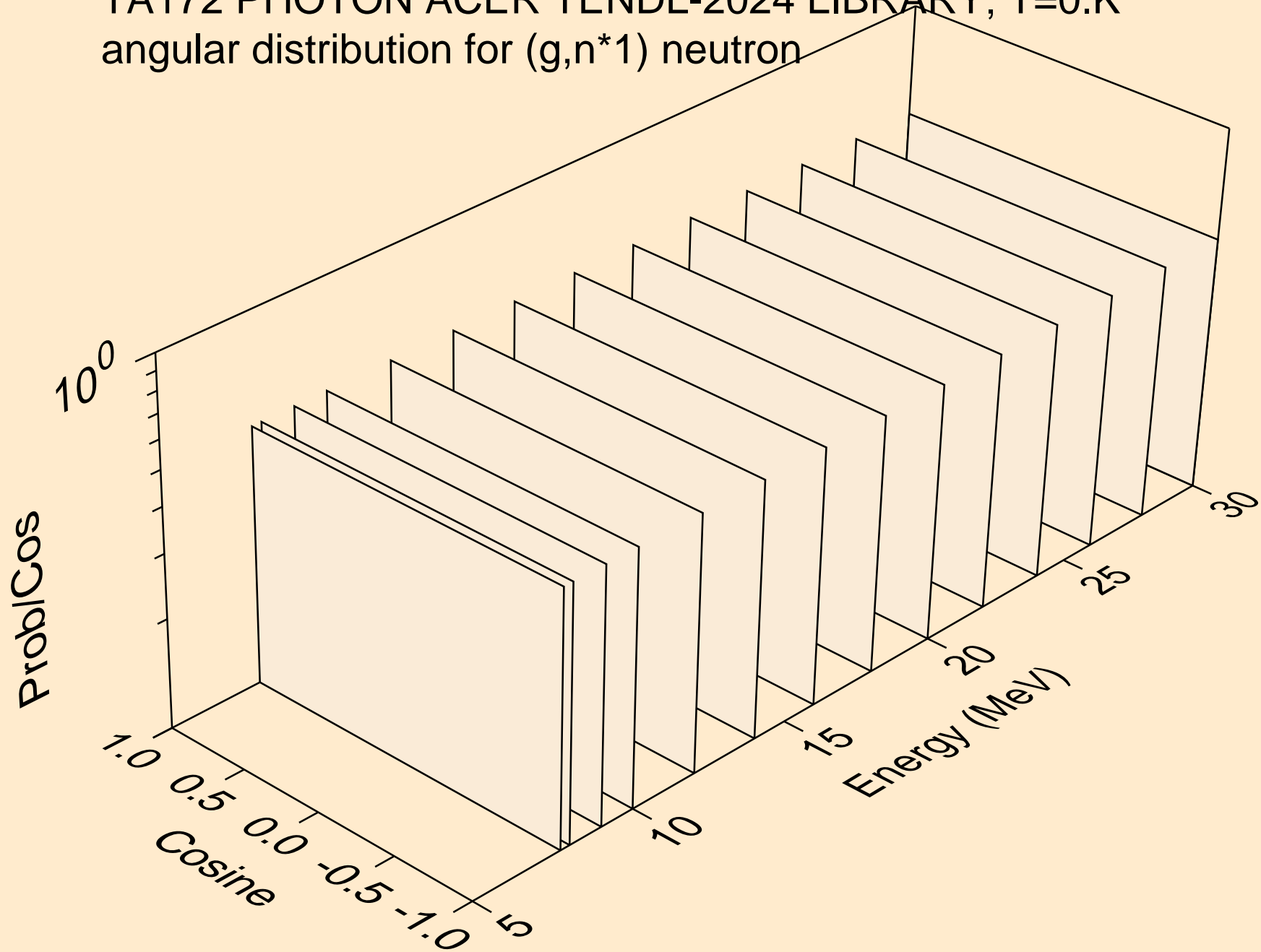

TA172 PHOTON ACER TENDL-2024 LIBRARY; T=0.K
neutrons from (g,n*c)

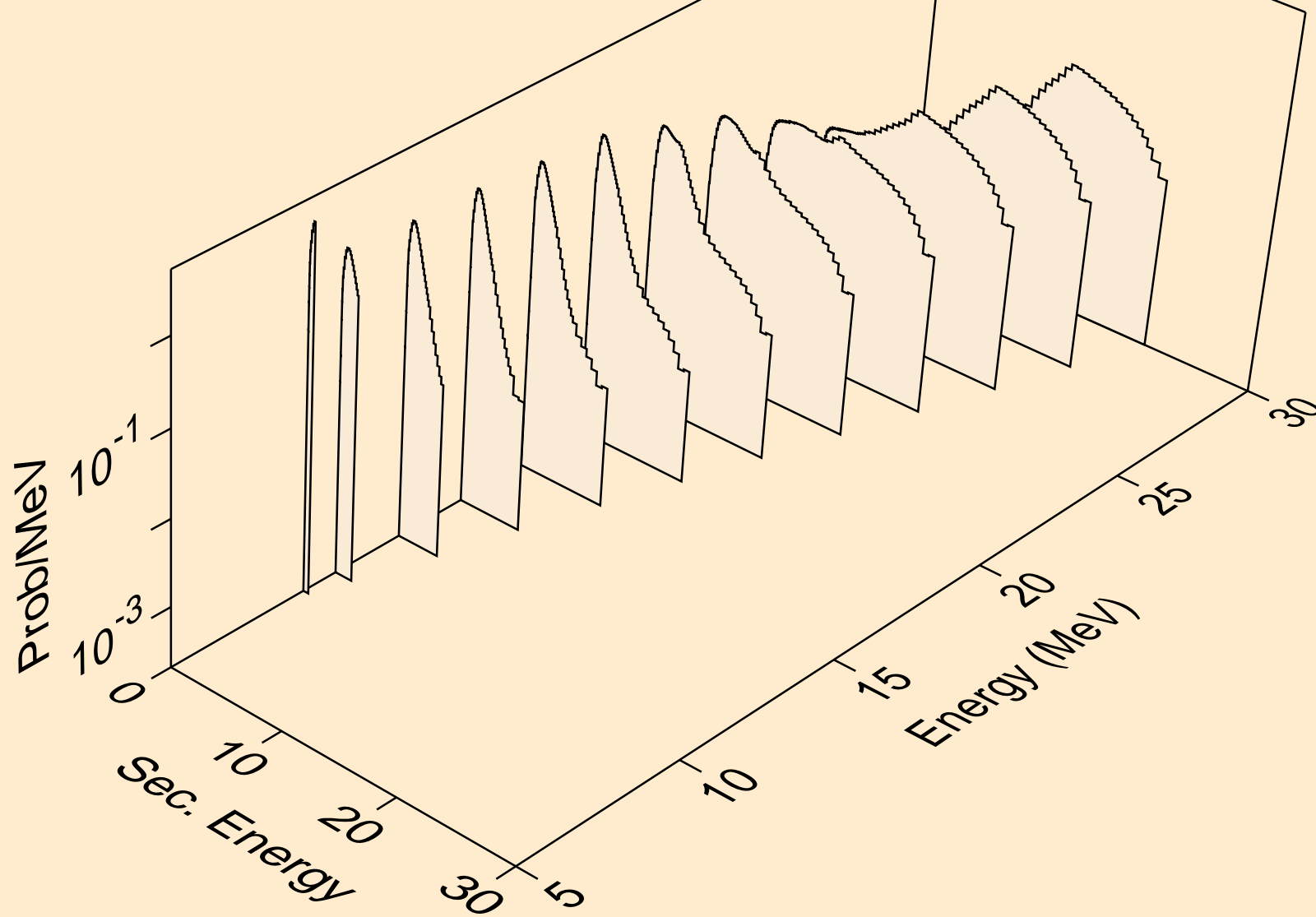

TA172 PHOTON ACER TENDL-2024 LIBRARY; T=0.K
photons from (g,x)

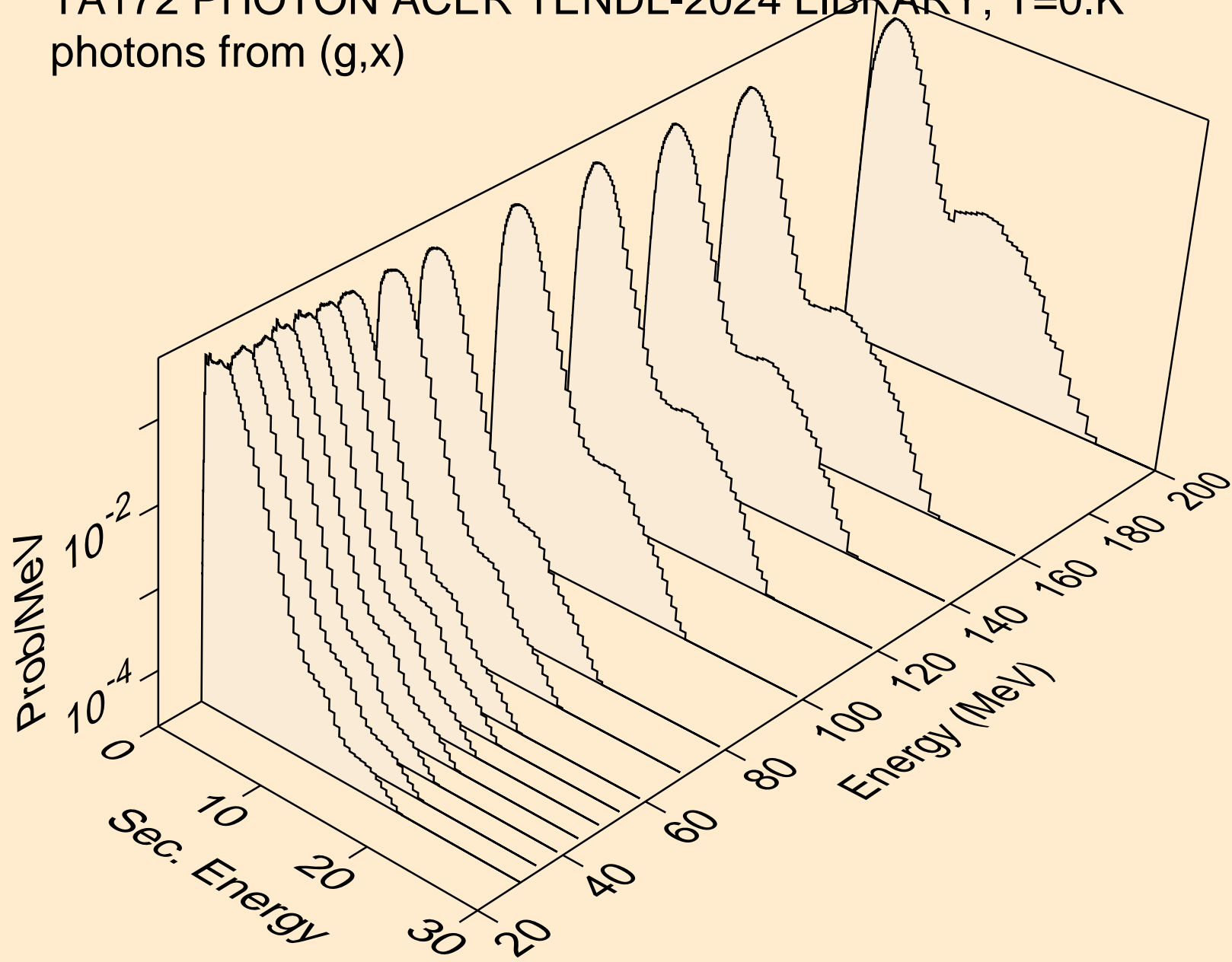

TA172 PHOTON ACER TENDL-2024 LIBRARY; T=0.K
photons from (g,2n)

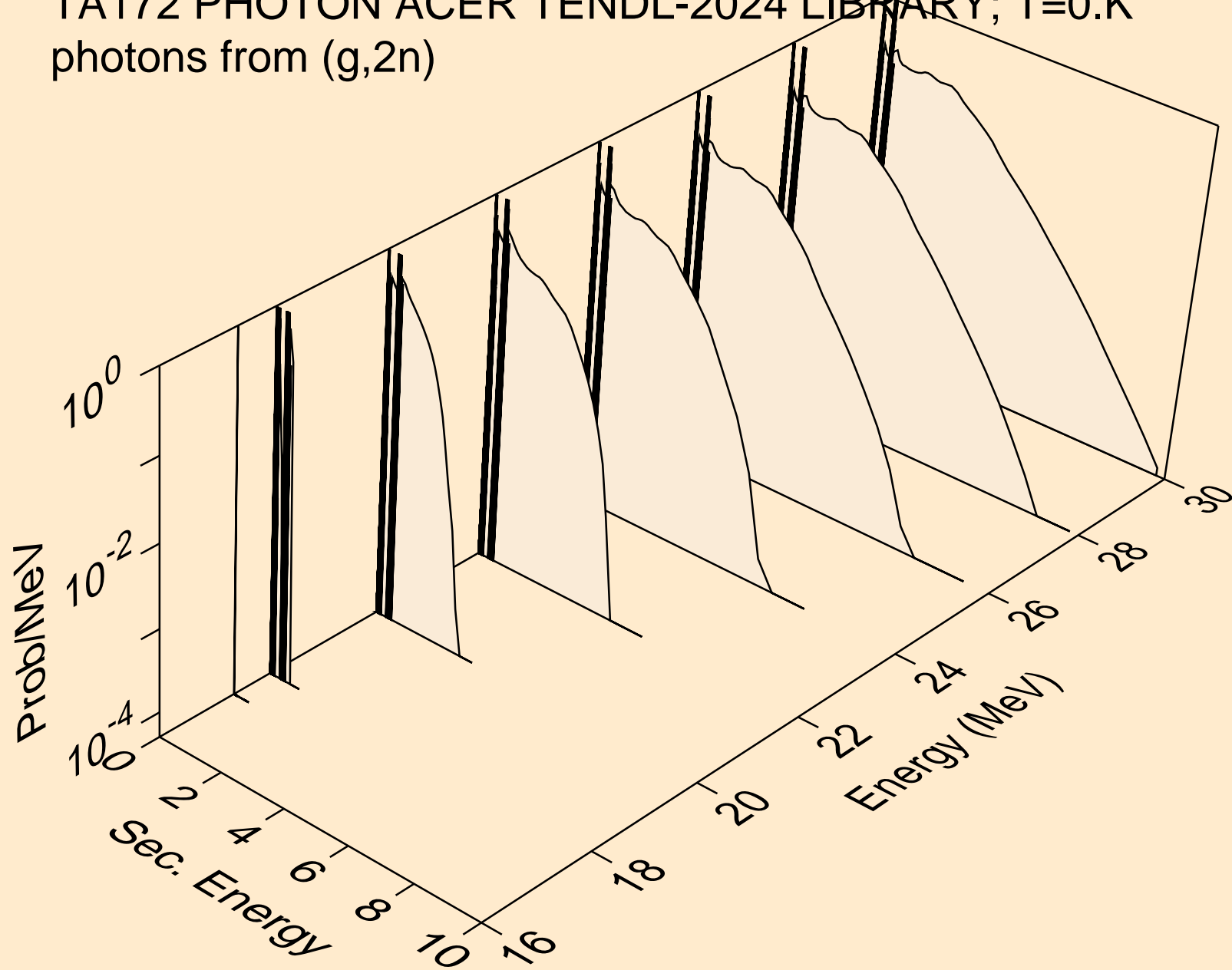

TA172 PHOTON ACER TENDL-2024 LIBRARY; T=0.K
photons from (g,3n)

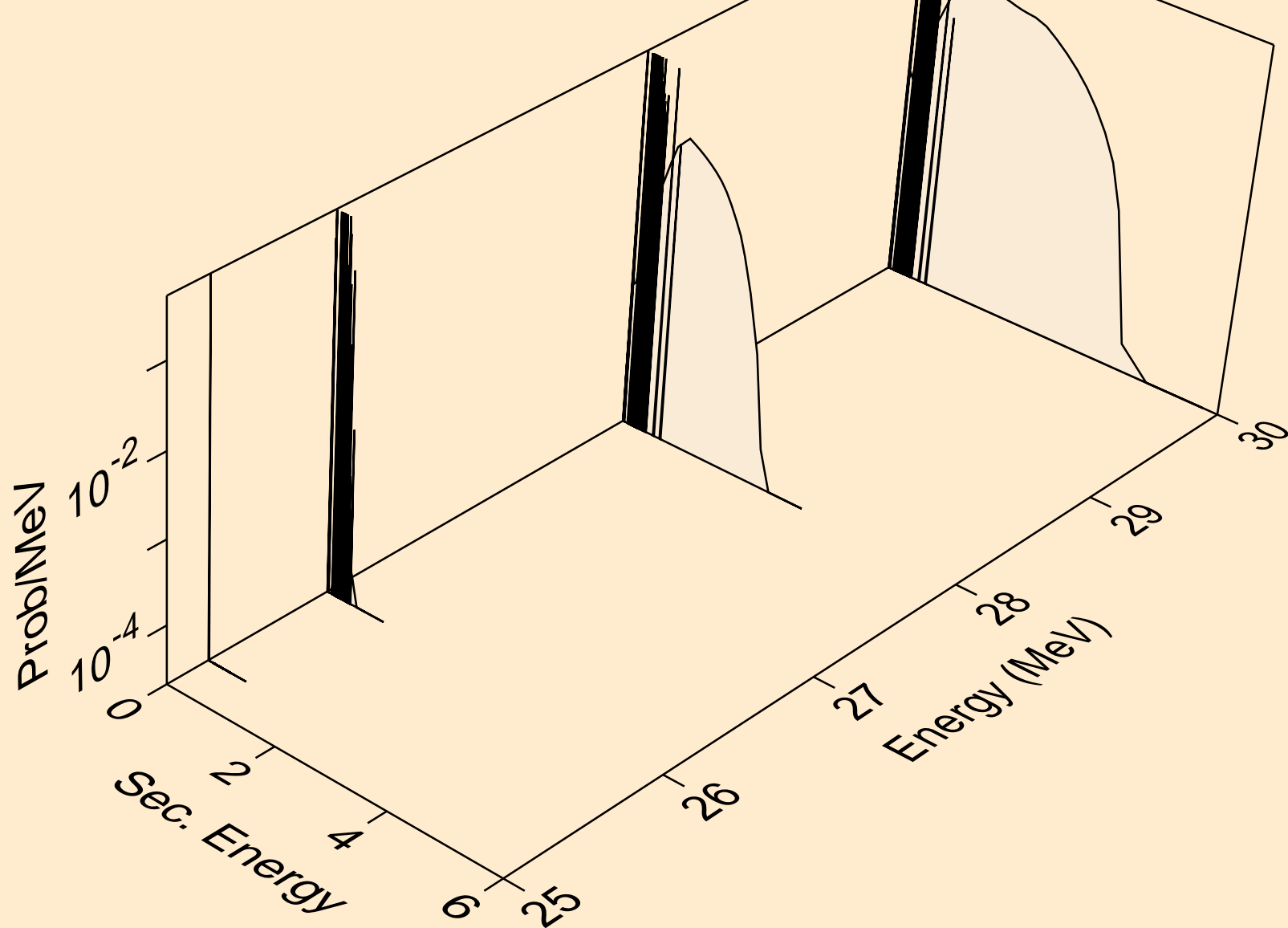

TA172 PHOTON ACER TENDL-2024 LIBRARY; T=0.K
photons from (g,n*)a

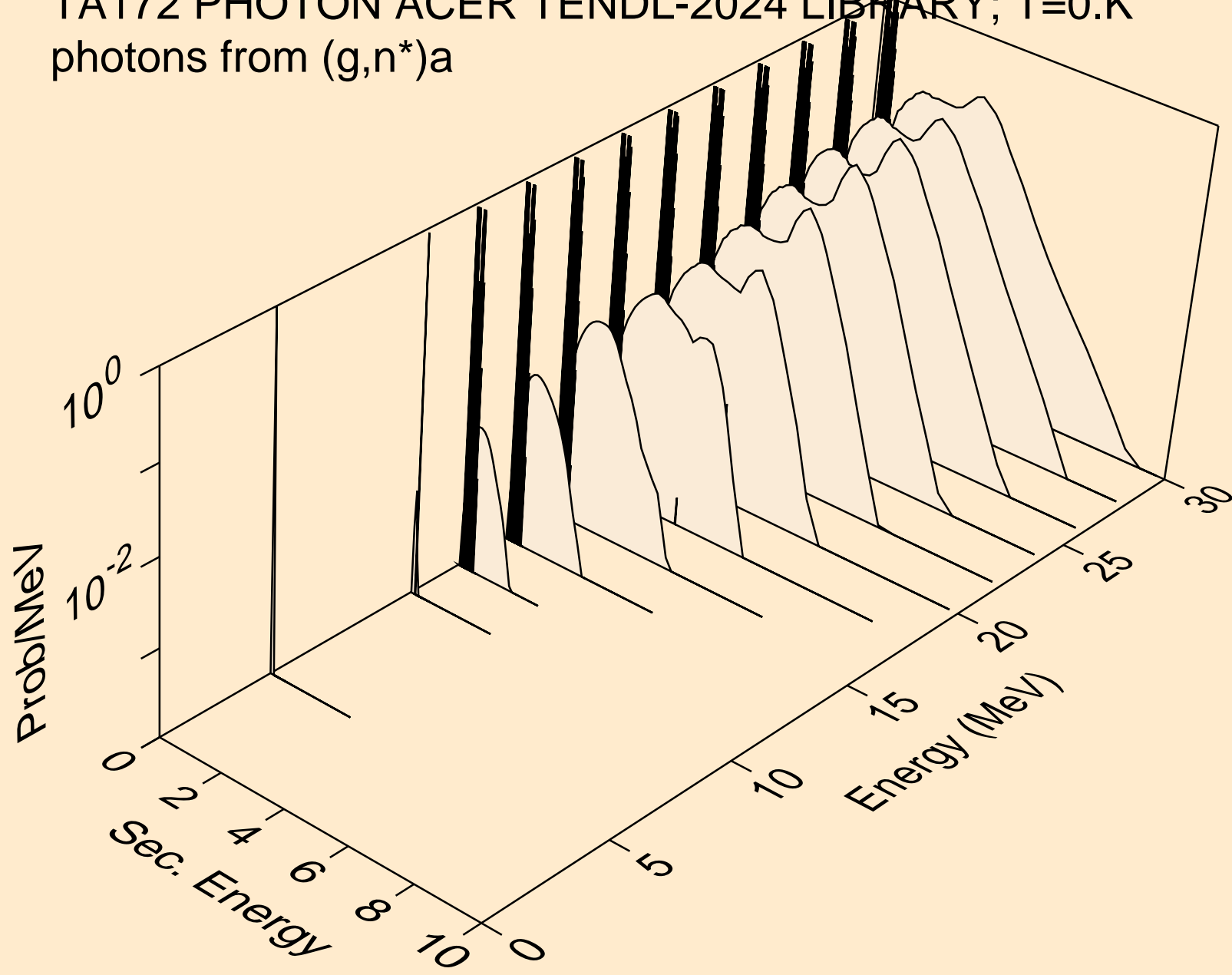

TA172 PHOTON ACER TENDL-2024 LIBRARY; T=0.K
photons from (g,2n)a

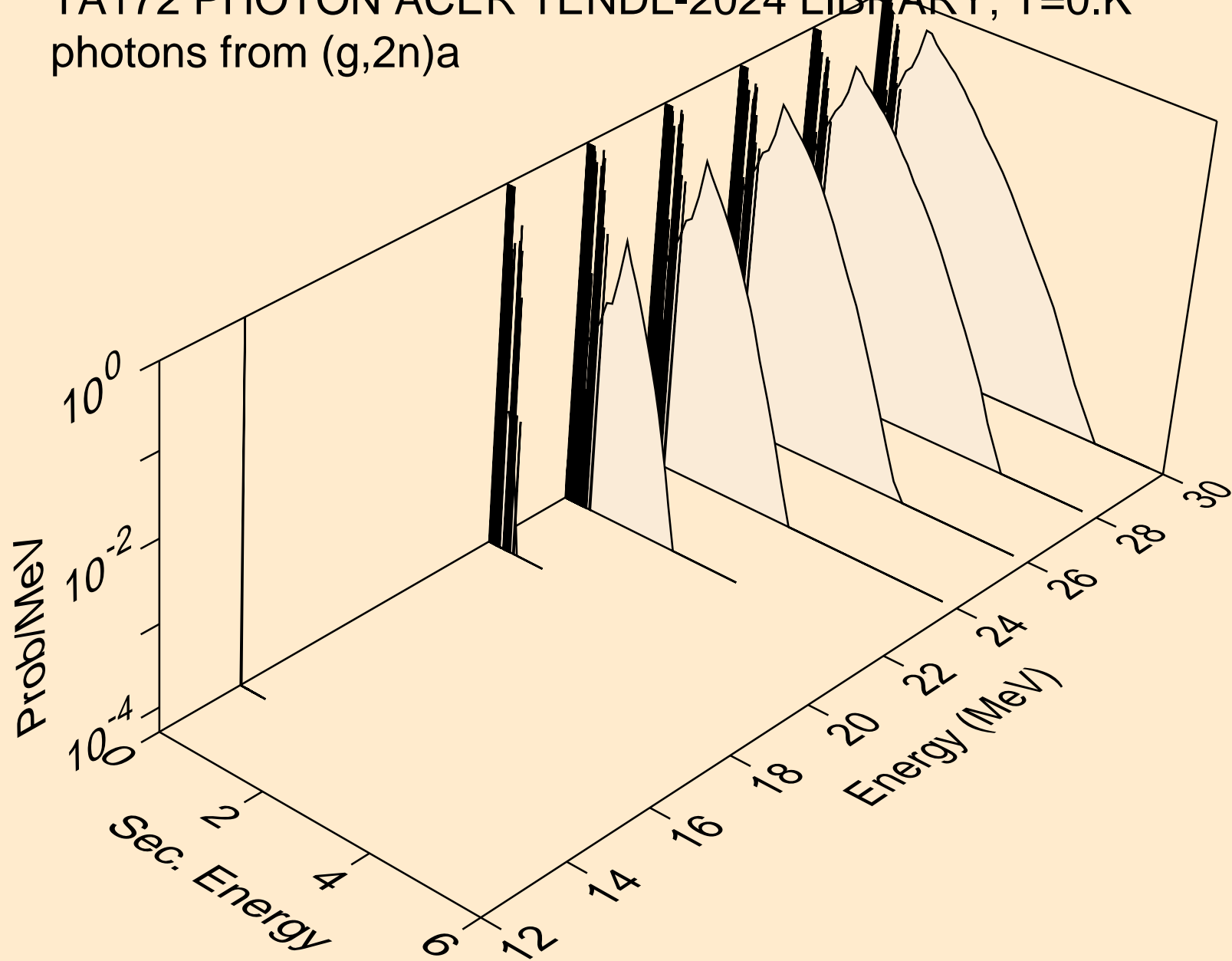

TA172 PHOTON ACER TENDL-2024 LIBRARY; T=0.K
photons from (g,n*)p

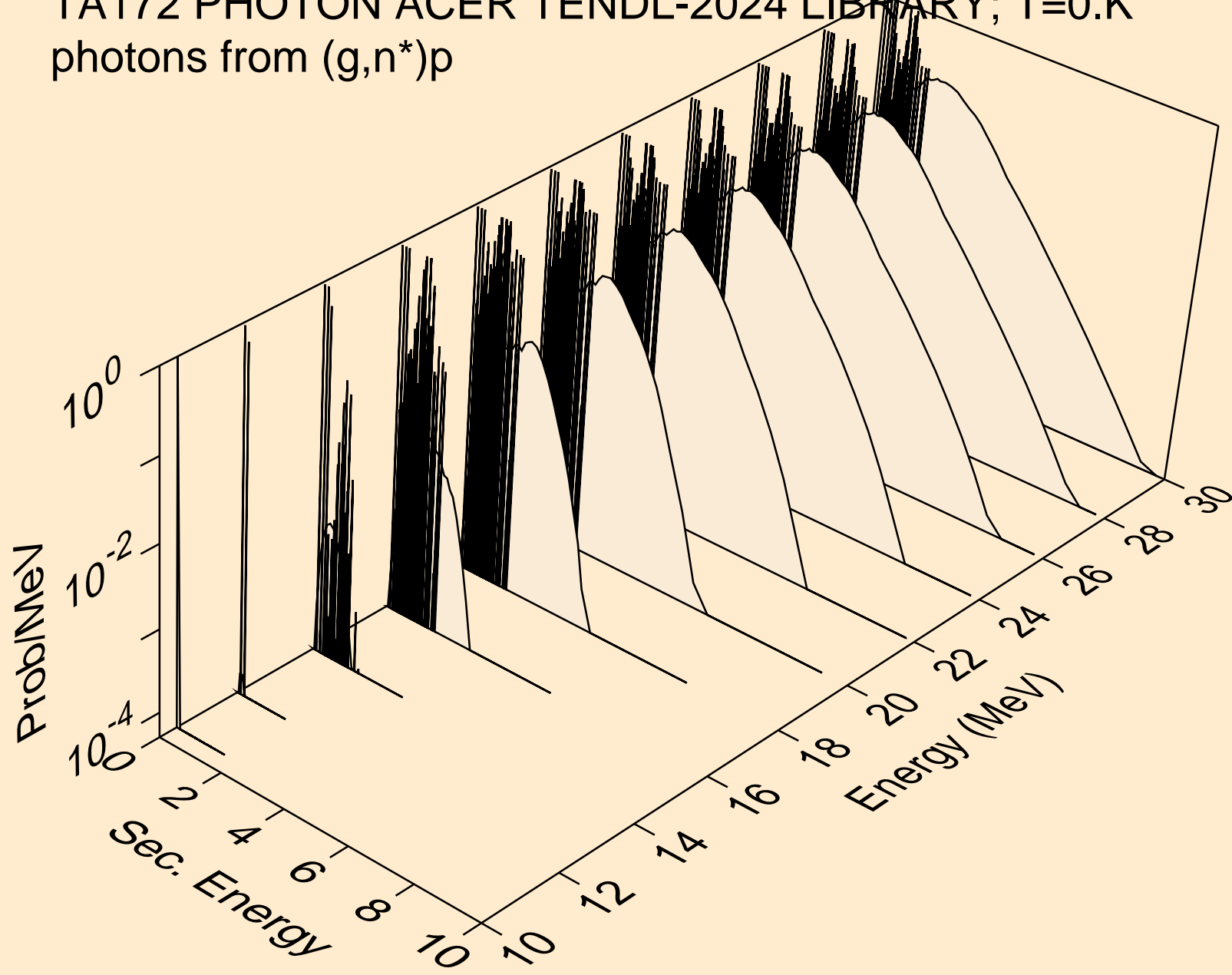

TA172 PHOTON ACER TENDL-2024 LIBRARY; T=0.K
photons from (g,n*)2a

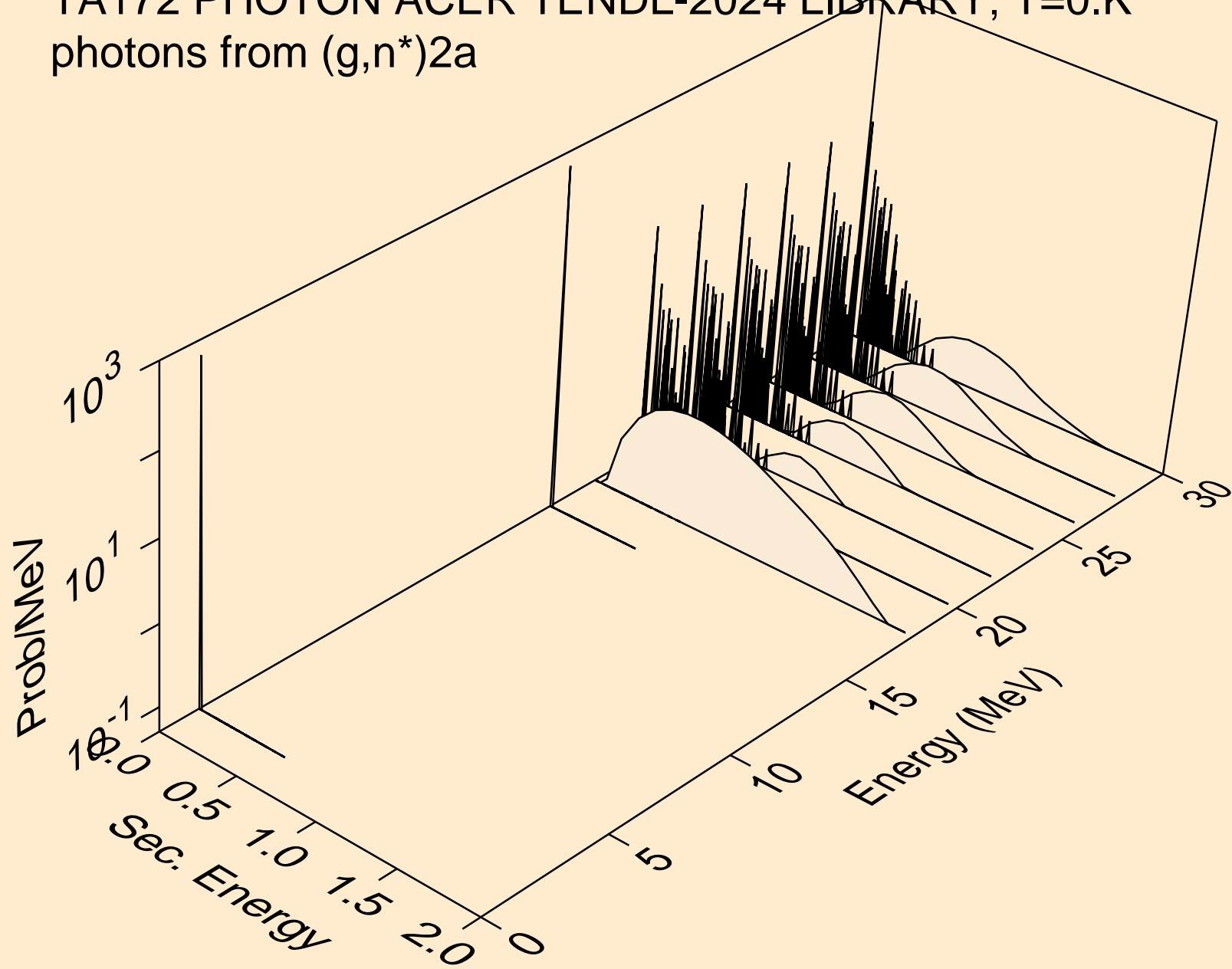

TA172 PHOTON ACER TENDL-2024 LIBRARY; T=0.K
photons from (g,n*)d

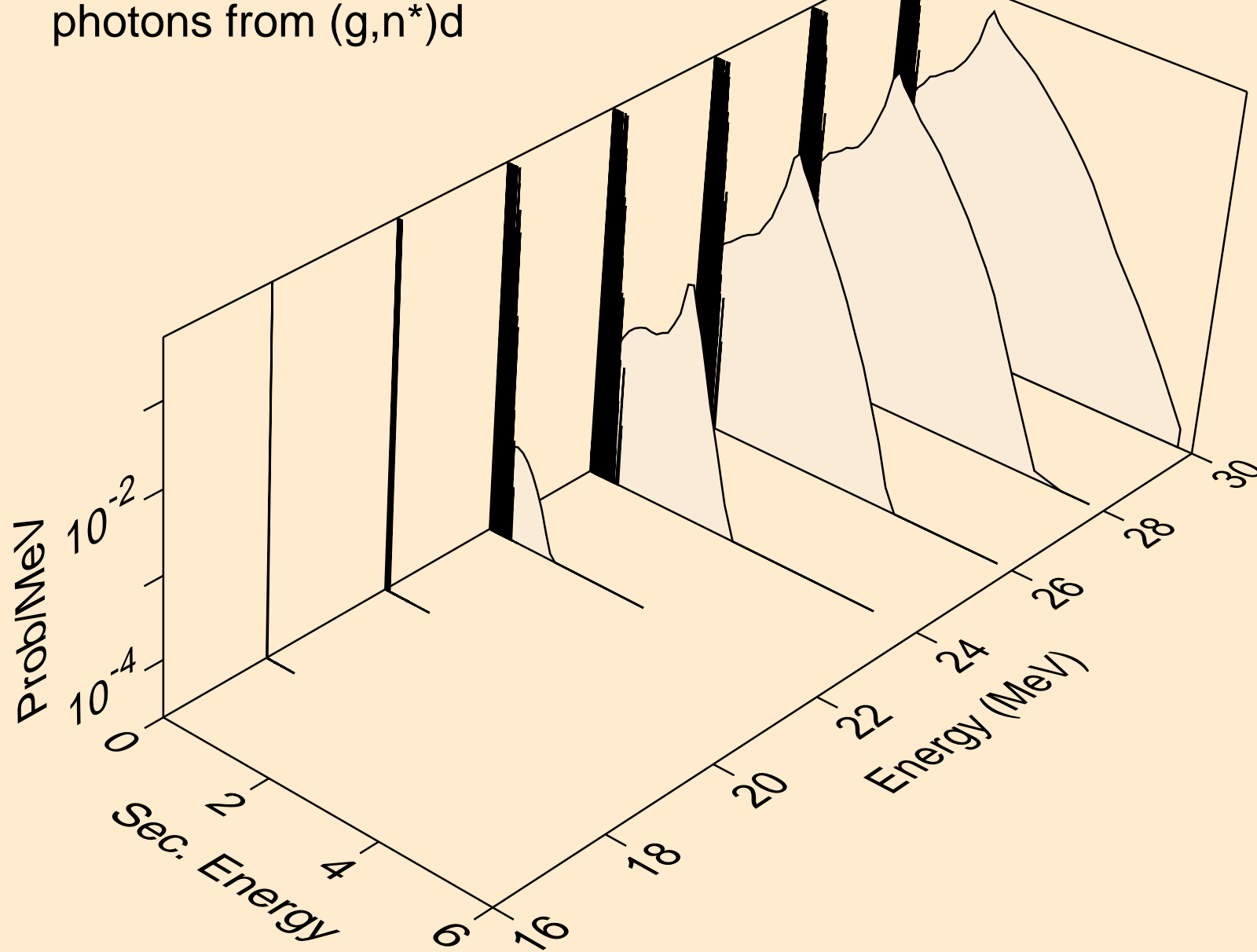

TA172 PHOTON ACER TENDL-2024 LIBRARY; T=0.K
photons from (g,n*)t

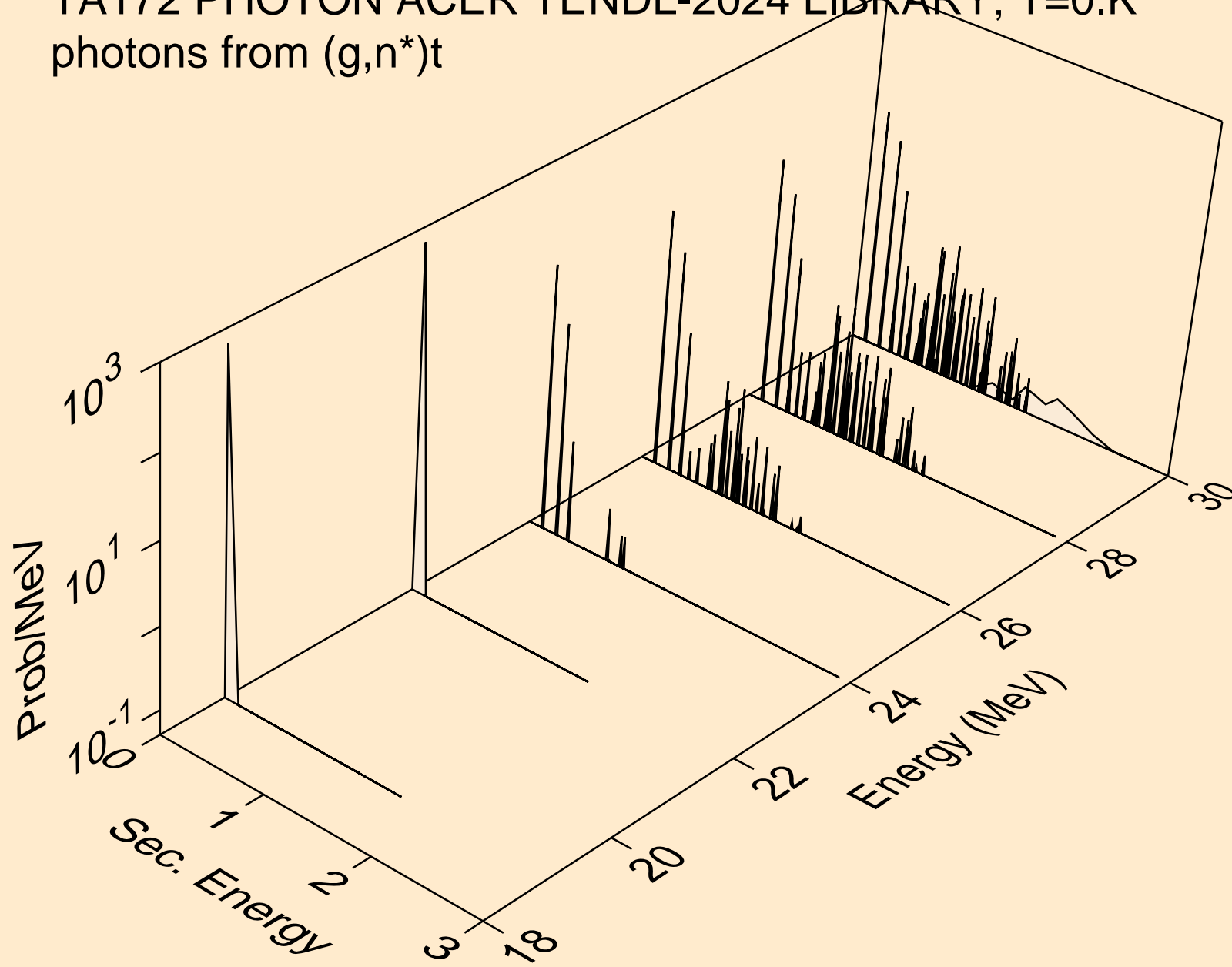

TA172 PHOTON ACER TENDL-2024 LIBRARY; T=0.K
photons from (g,2np)

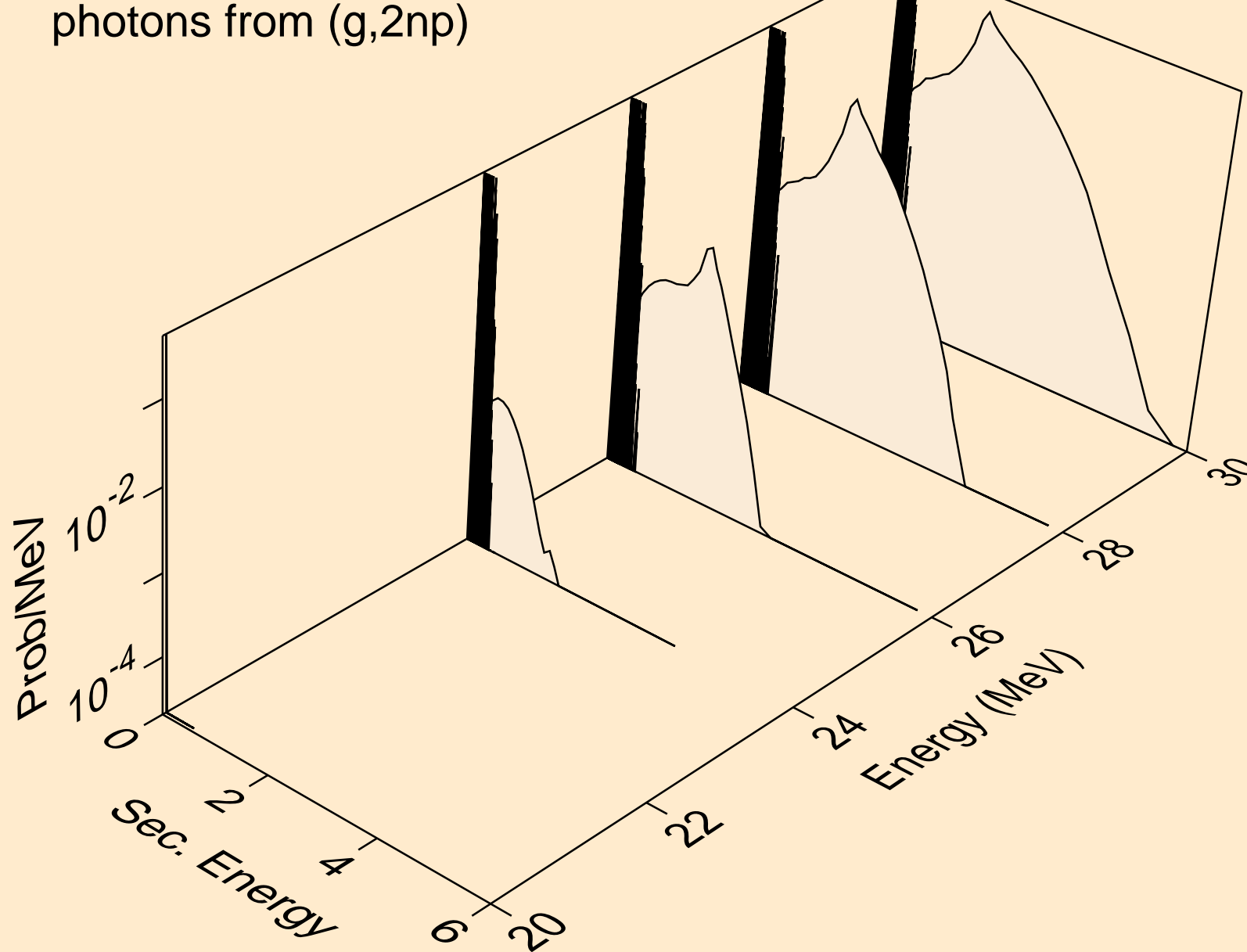

TA172 PHOTON ACER TENDL-2024 LIBRARY; T=0.K
photons from (g,n2p)

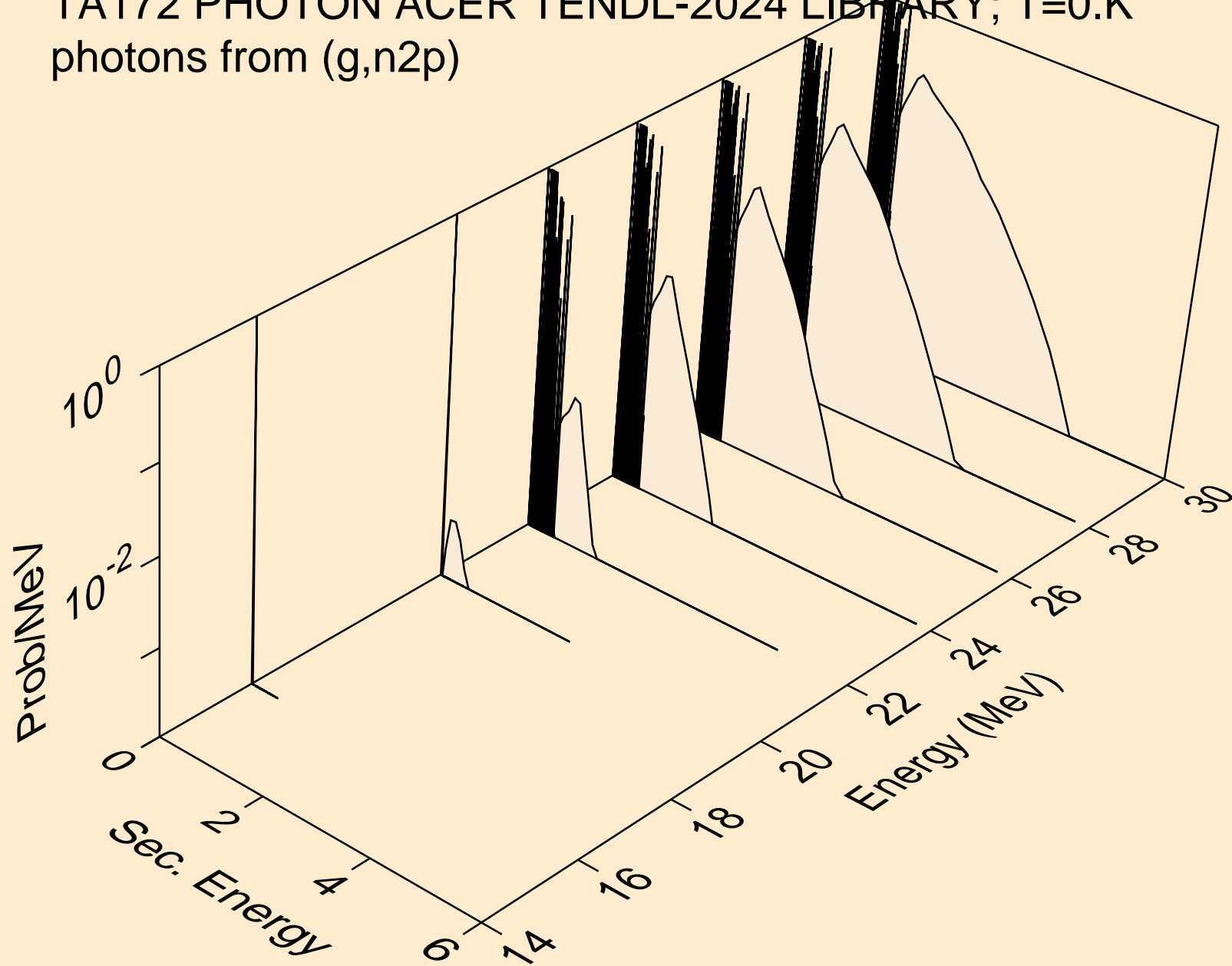

TA172 PHOTON ACER TENDL-2024 LIBRARY; T=0.K
photons from (g,npa)

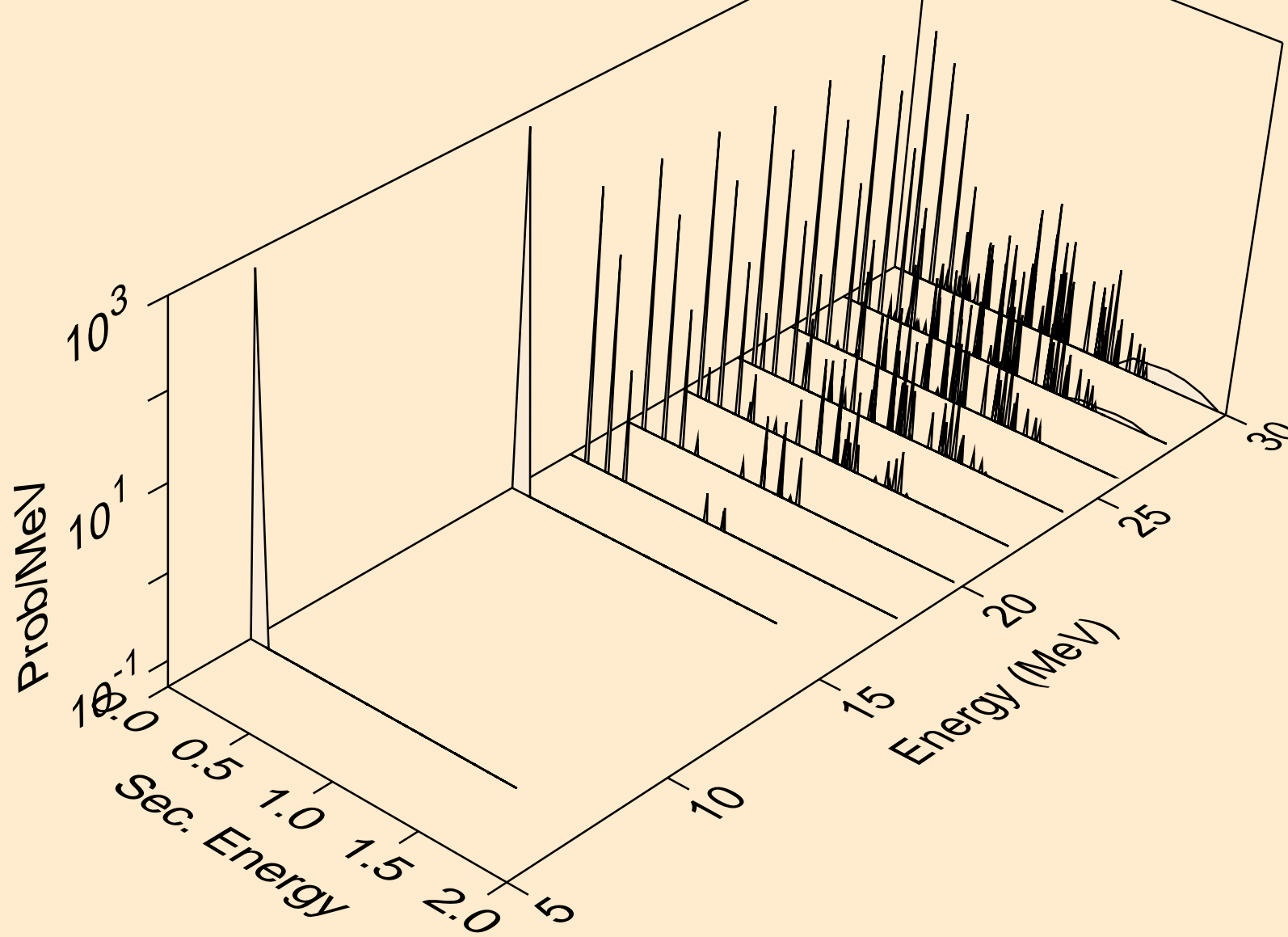

TA172 PHOTON ACER TENDL-2024 LIBRARY; T=0.K
photons from (g,n*c)

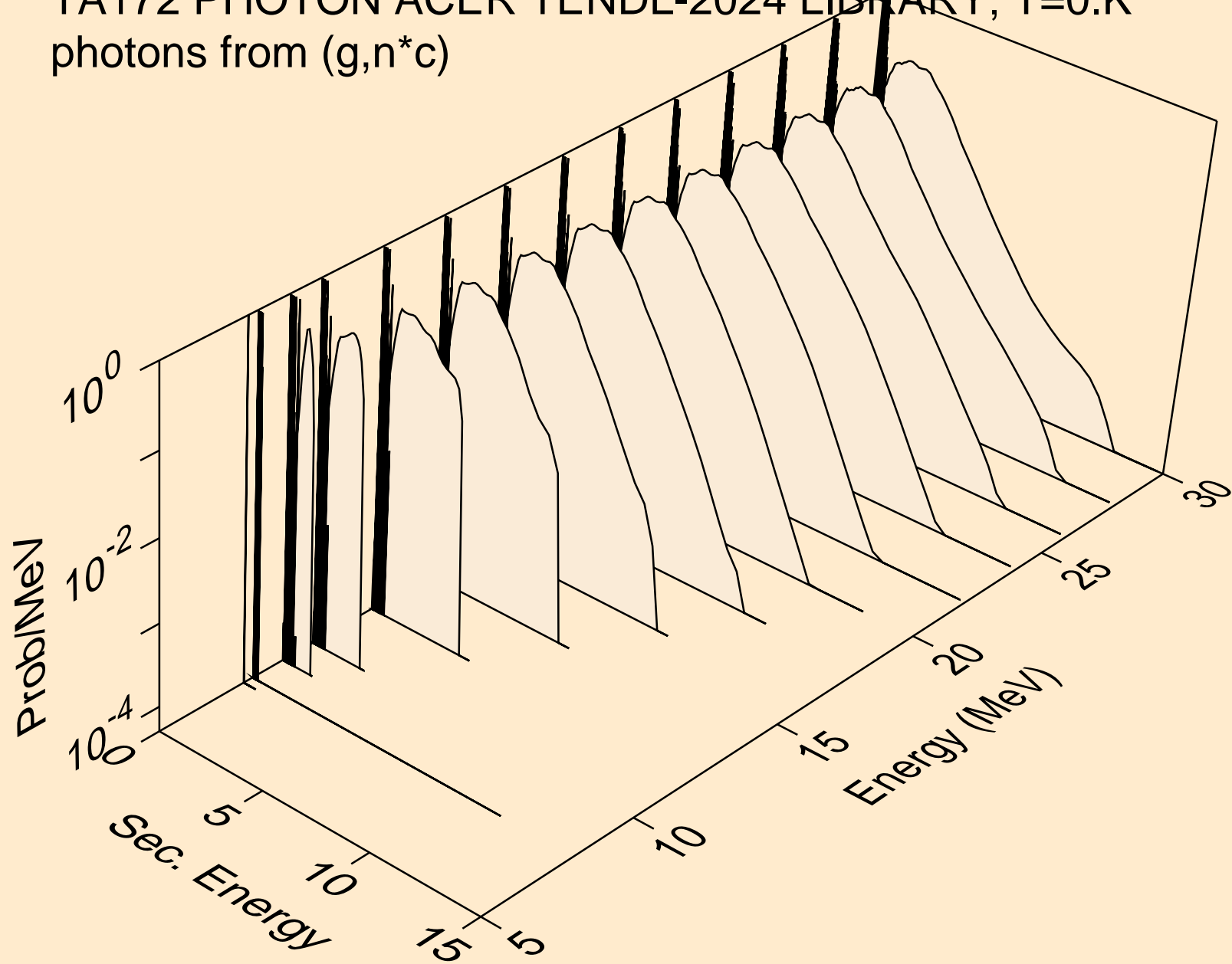

TA172 PHOTON ACER TENDL-2024 LIBRARY; T=0.K
photons from (g,gma)

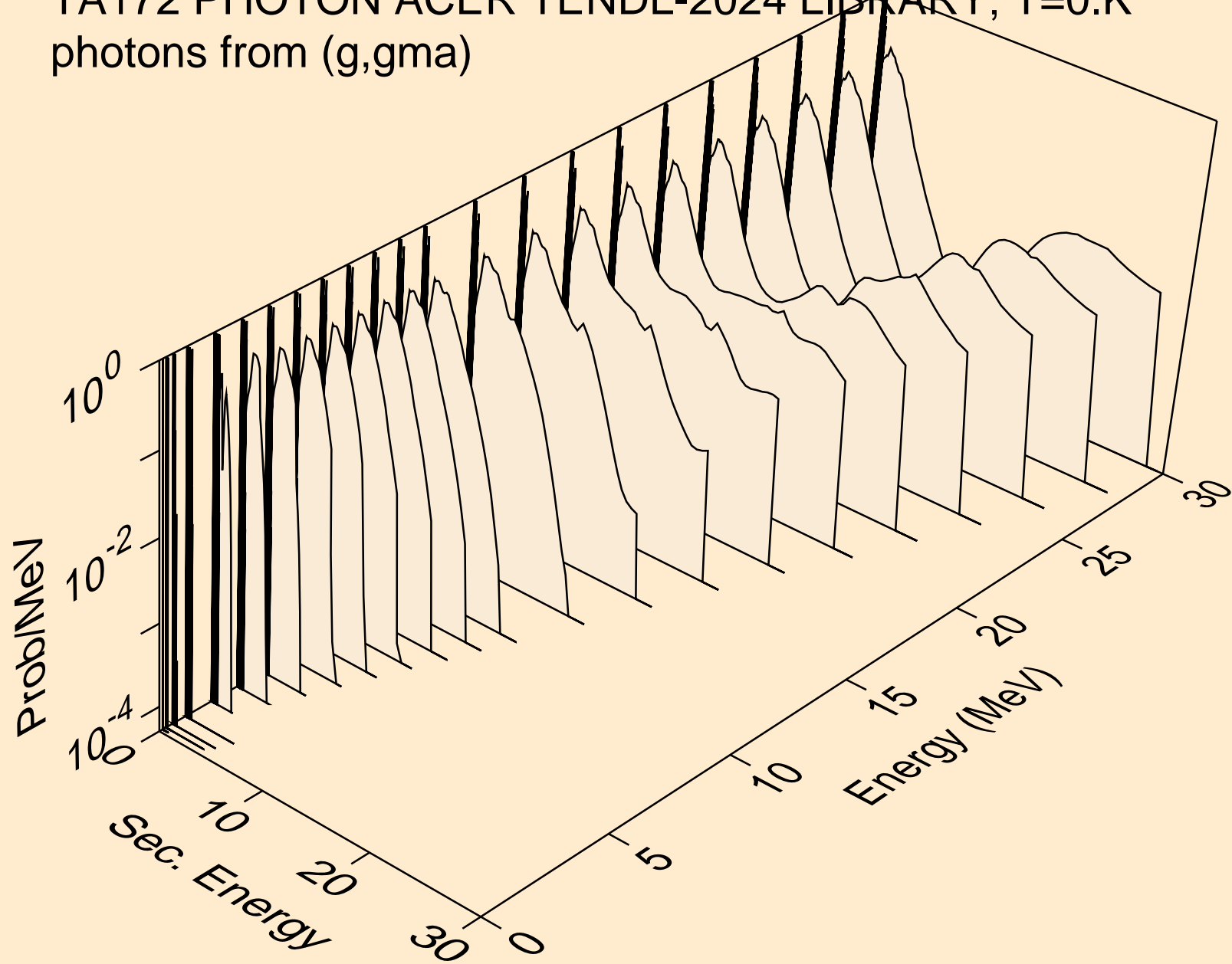

TA172 PHOTON ACER TENDL-2024 LIBRARY; T=0.K
photons from (g,p)

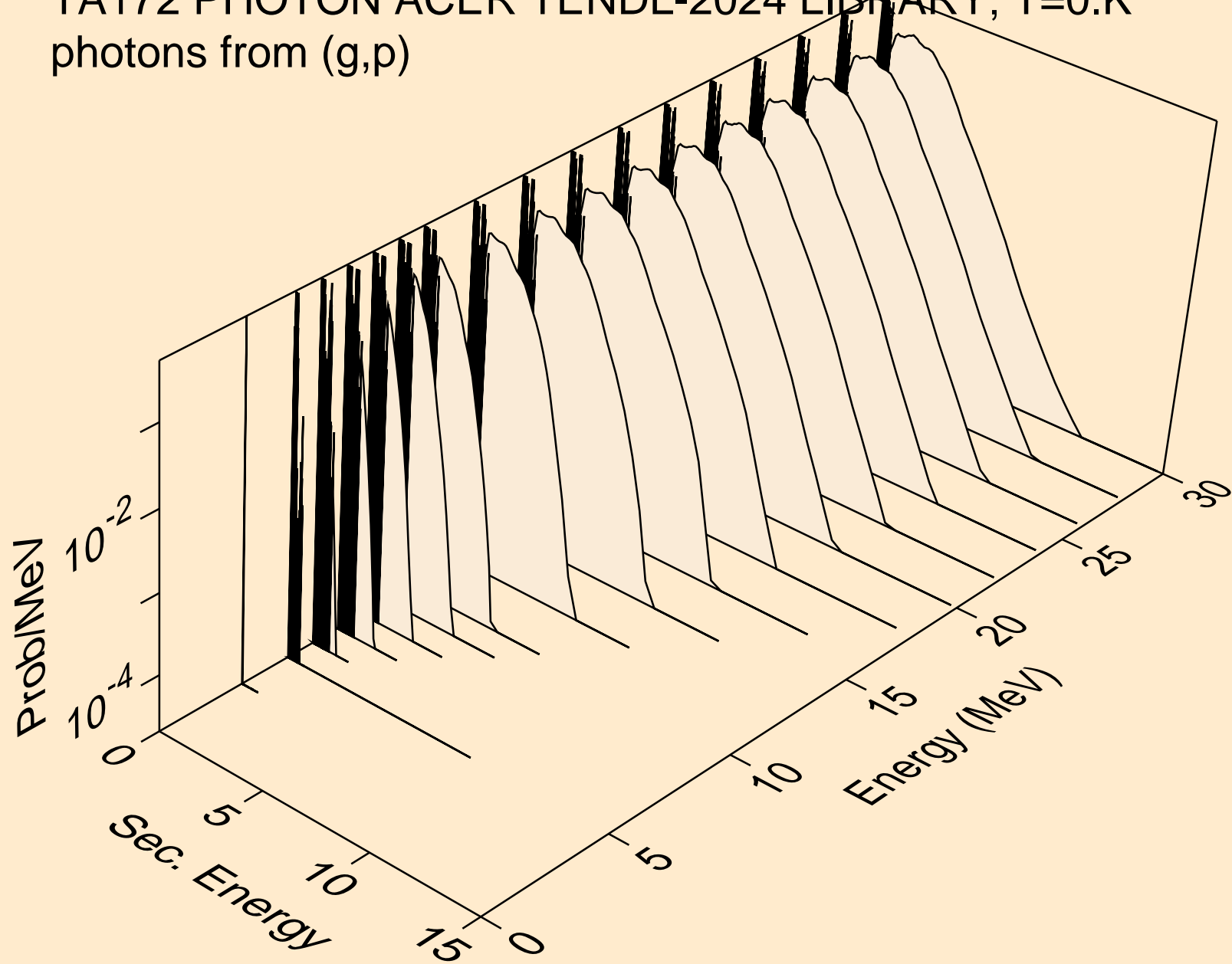

TA172 PHOTON ACER TENDL-2024 LIBRARY; T=0.K
photons from (g,d)

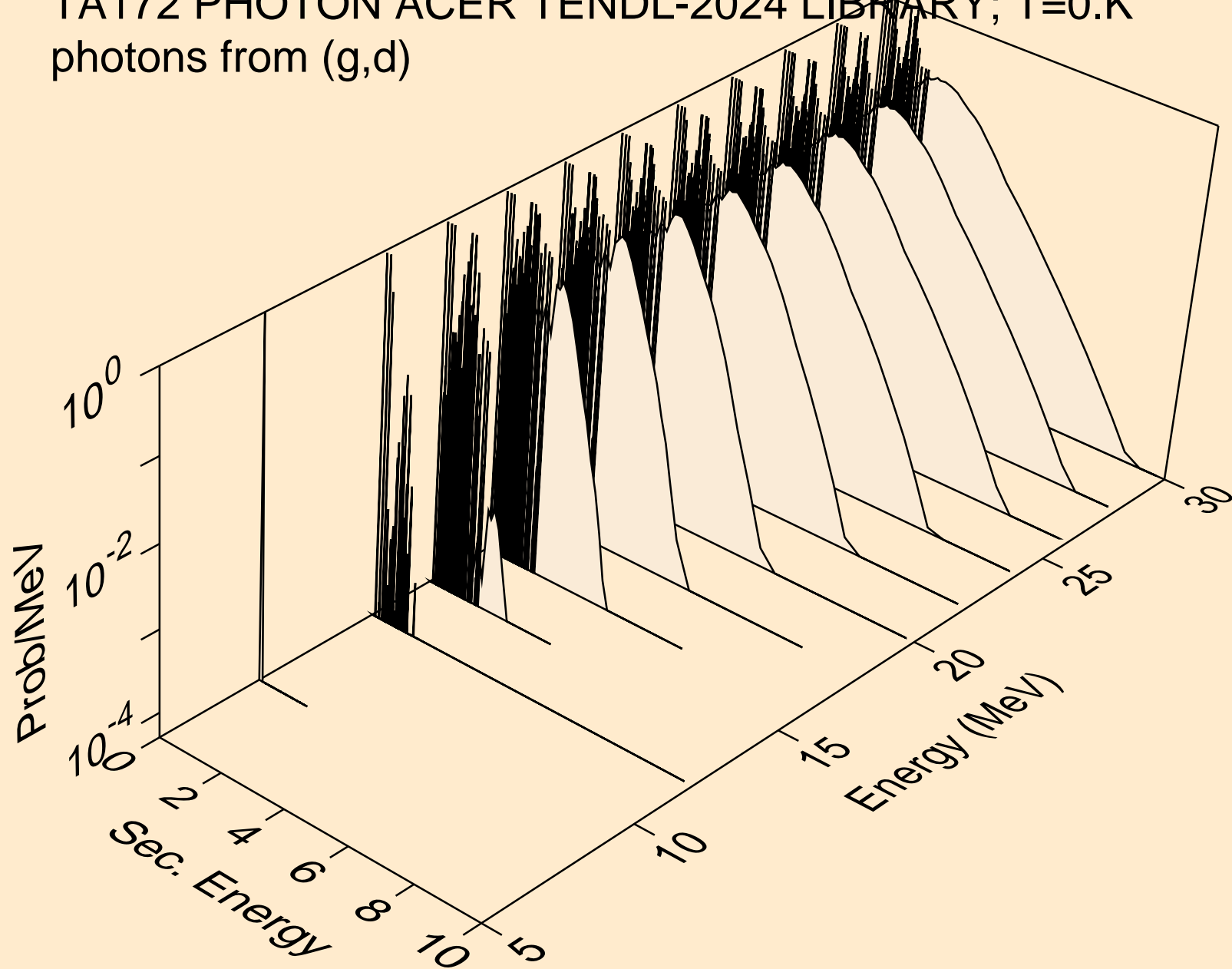

TA172 PHOTON ACER TENDL-2024 LIBRARY; T=0.K
photons from (g,t)

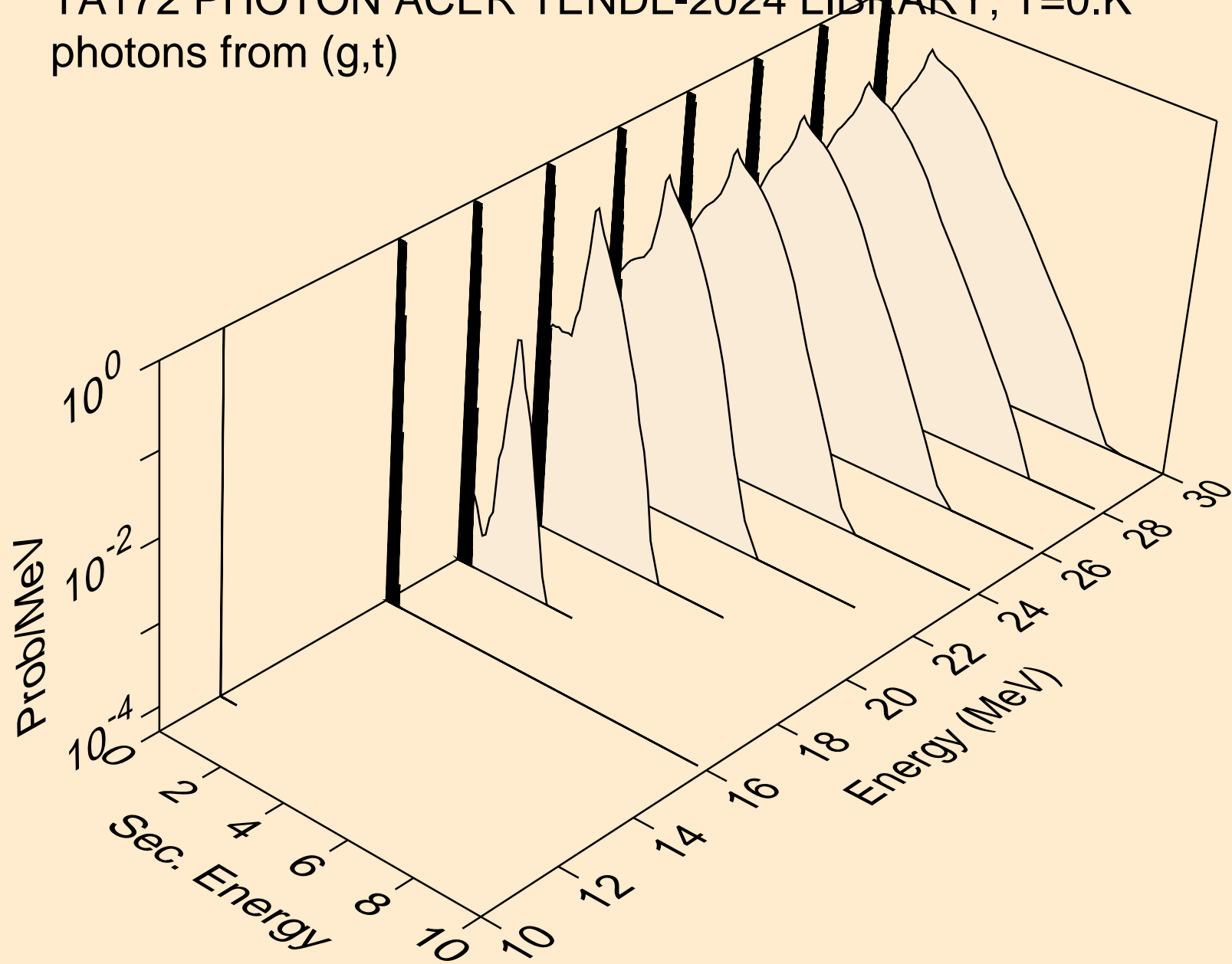

TA172 PHOTON ACER TENDL-2024 LIBRARY; T=0.K
photons from (g,he3)

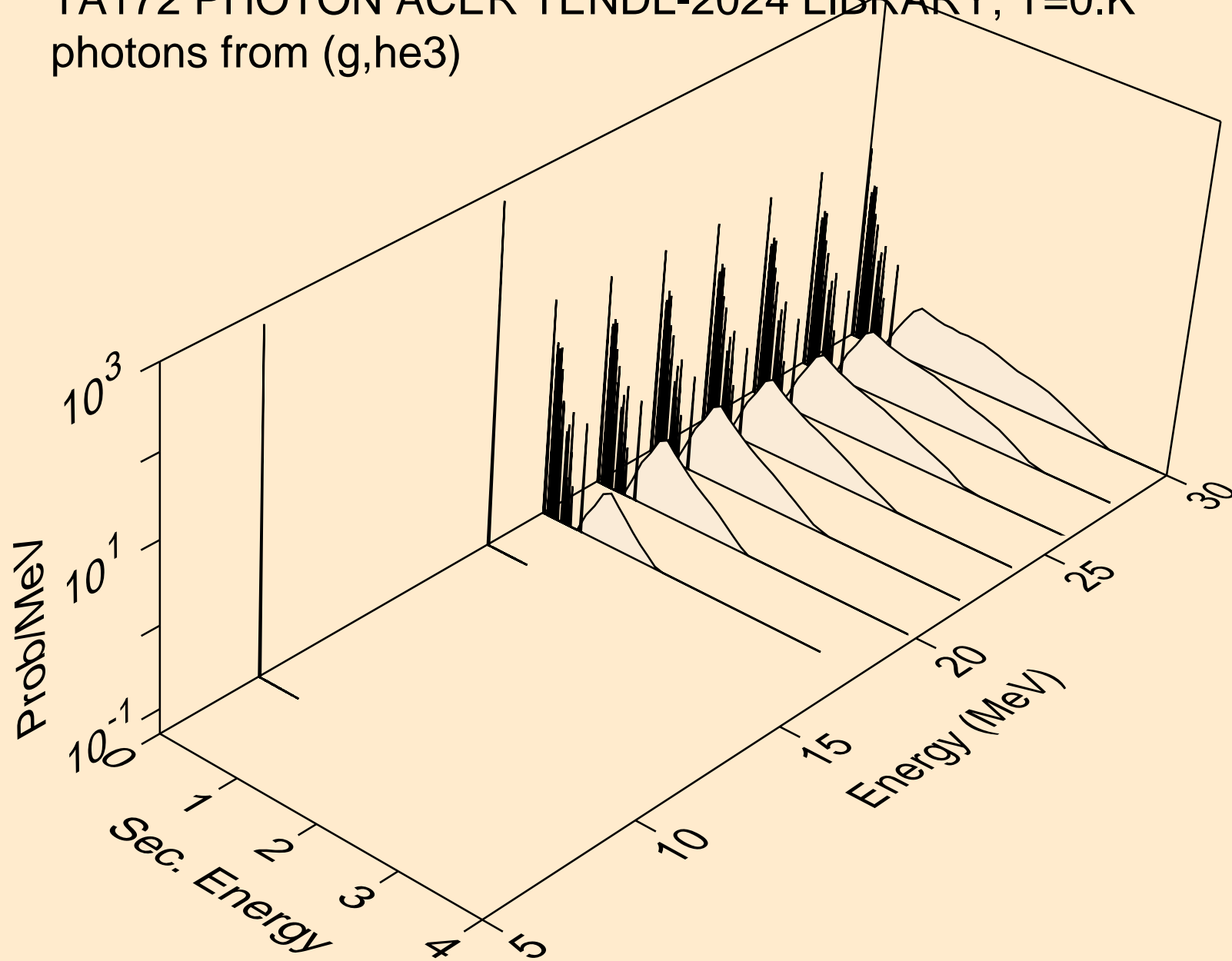

TA172 PHOTON ACER TENDL-2024 LIBRARY; T=0.K
photons from (g,a)

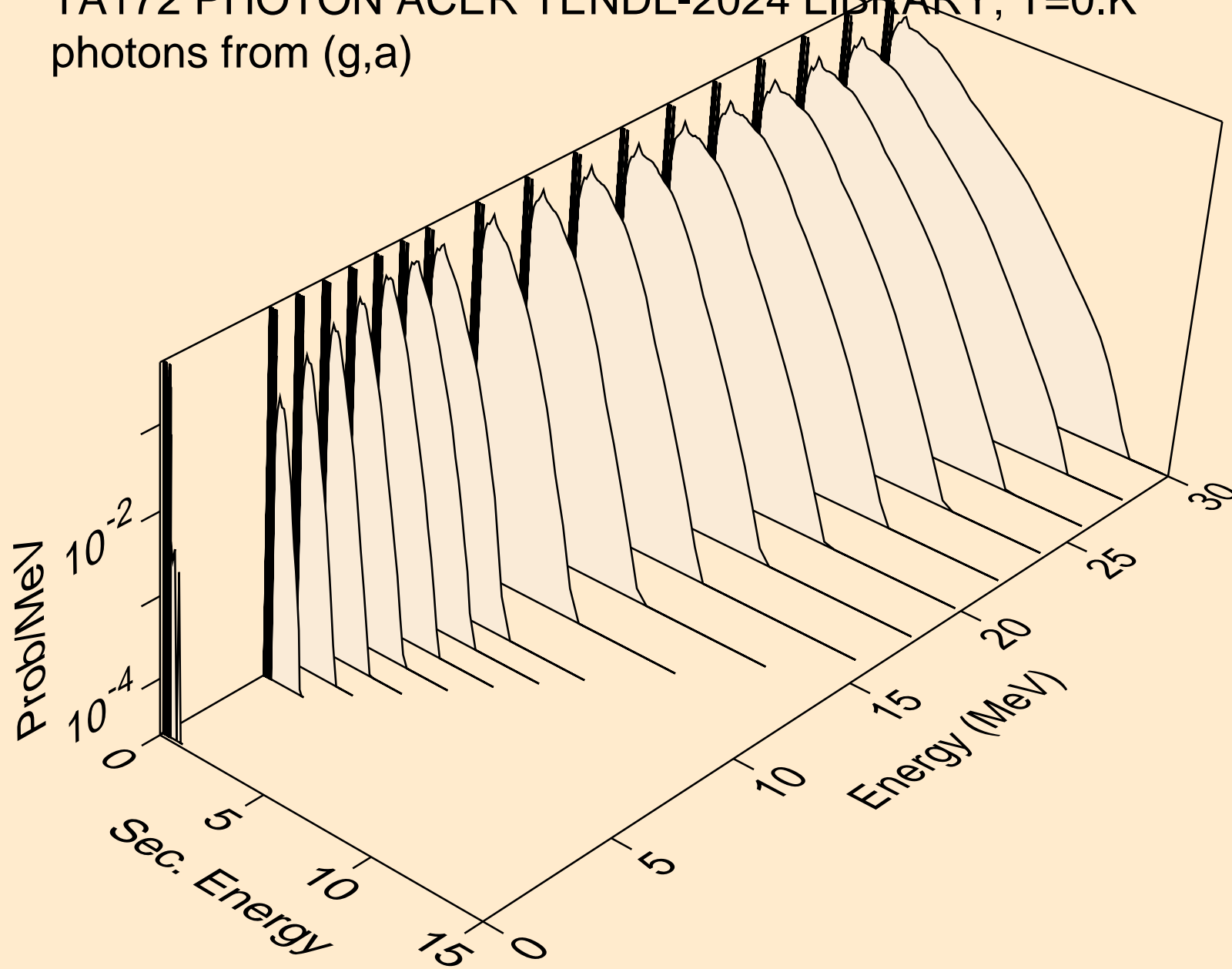

TA172 PHOTON ACER TENDL-2024 LIBRARY; T=0.K
photons from (g,2a)

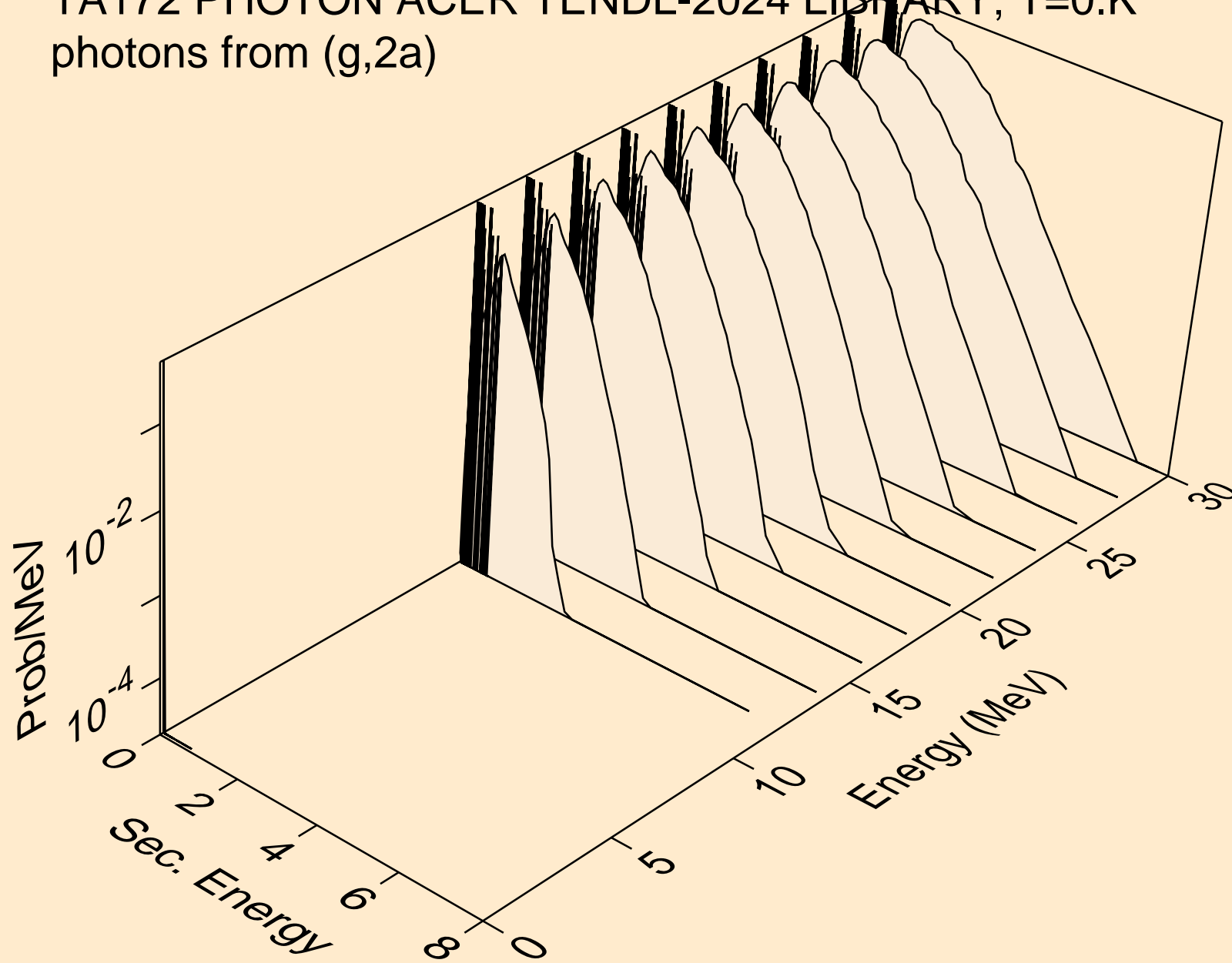

TA172 PHOTON ACER TENDL-2024 LIBRARY; T=0.K
photons from (g,2p)

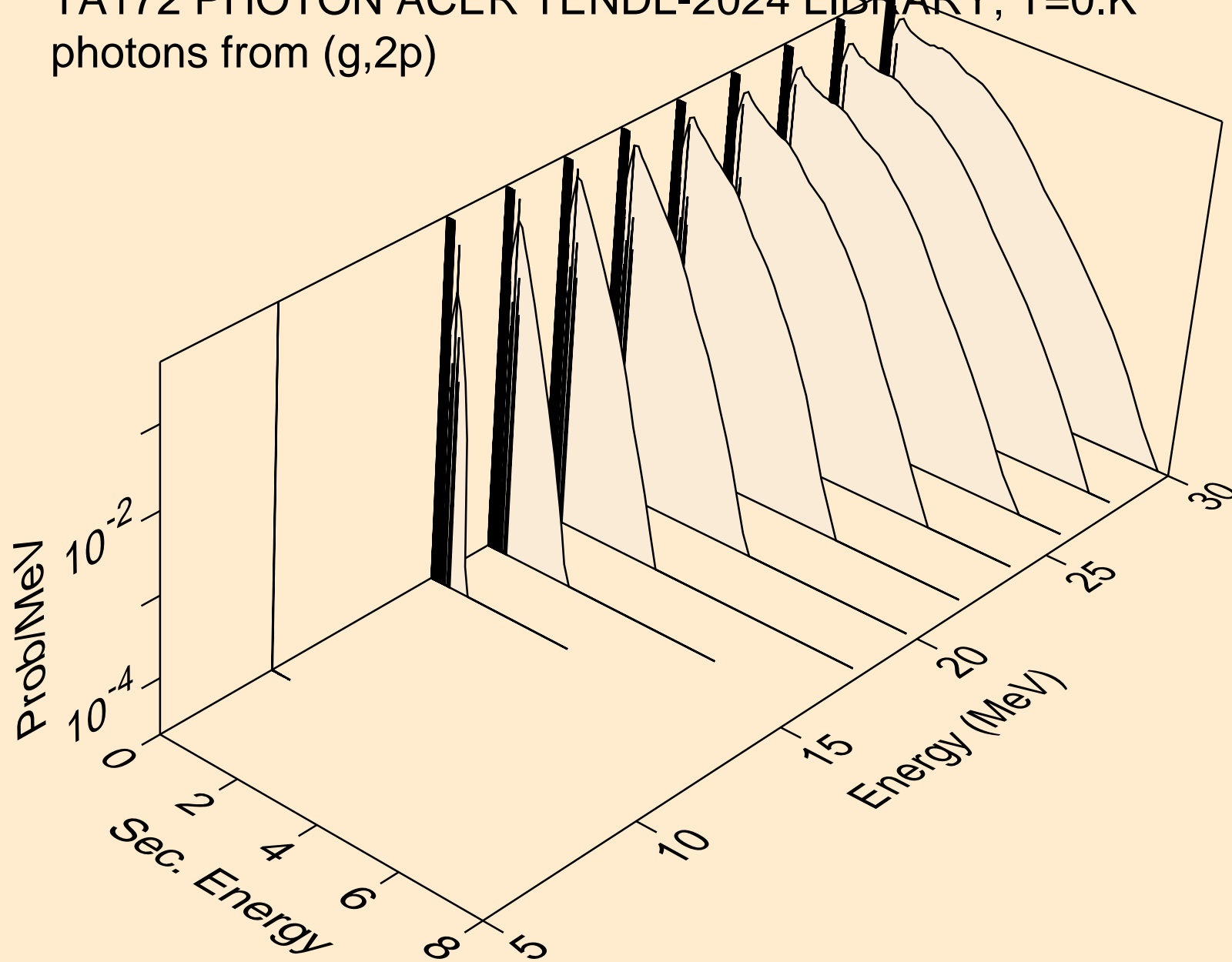

TA172 PHOTON ACER TENDL-2024 LIBRARY; T=0.K
photons from (g,pa)

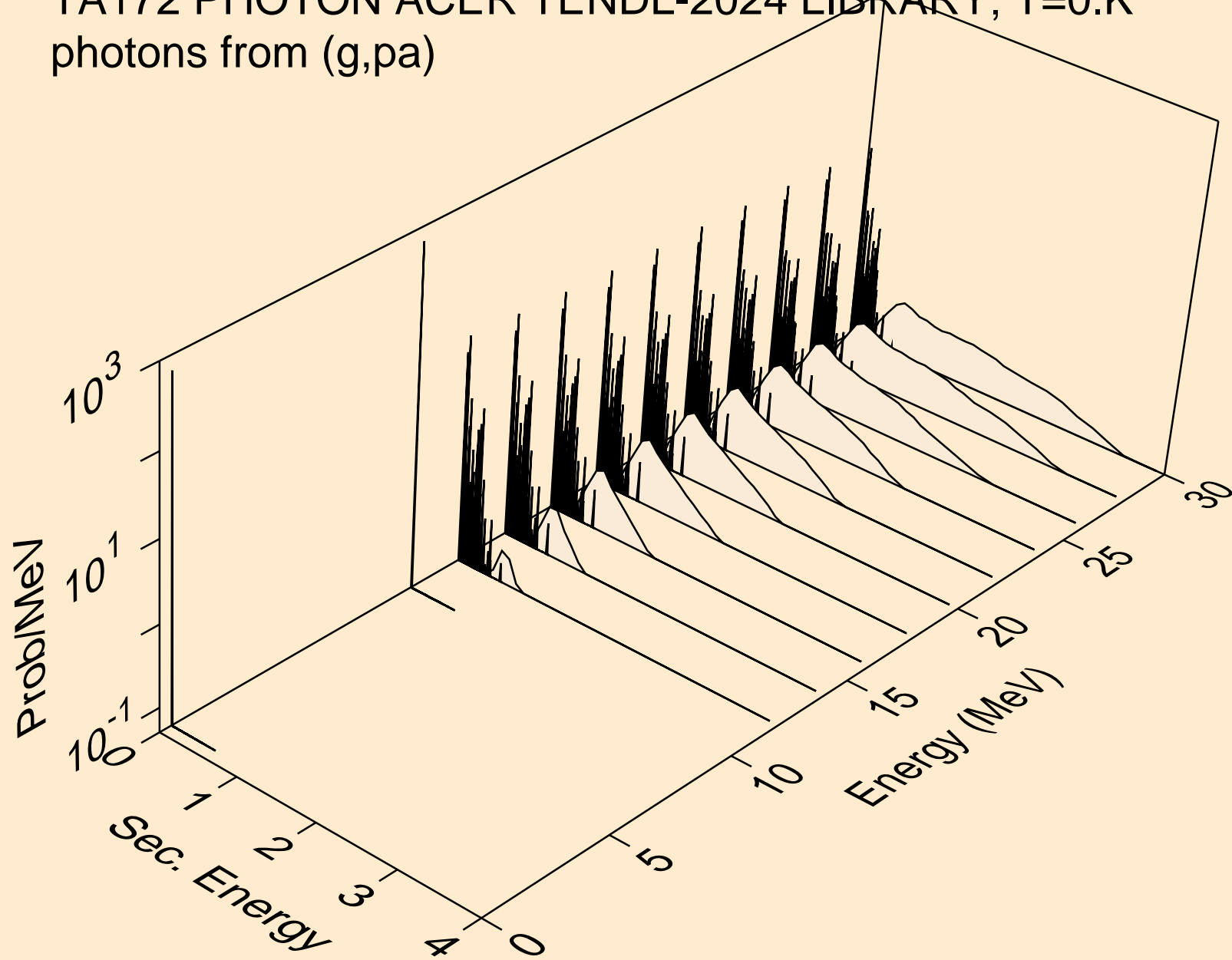

TA172 PHOTON ACER TENDL-2024 LIBRARY; T=0.K
photons from (g,pd)

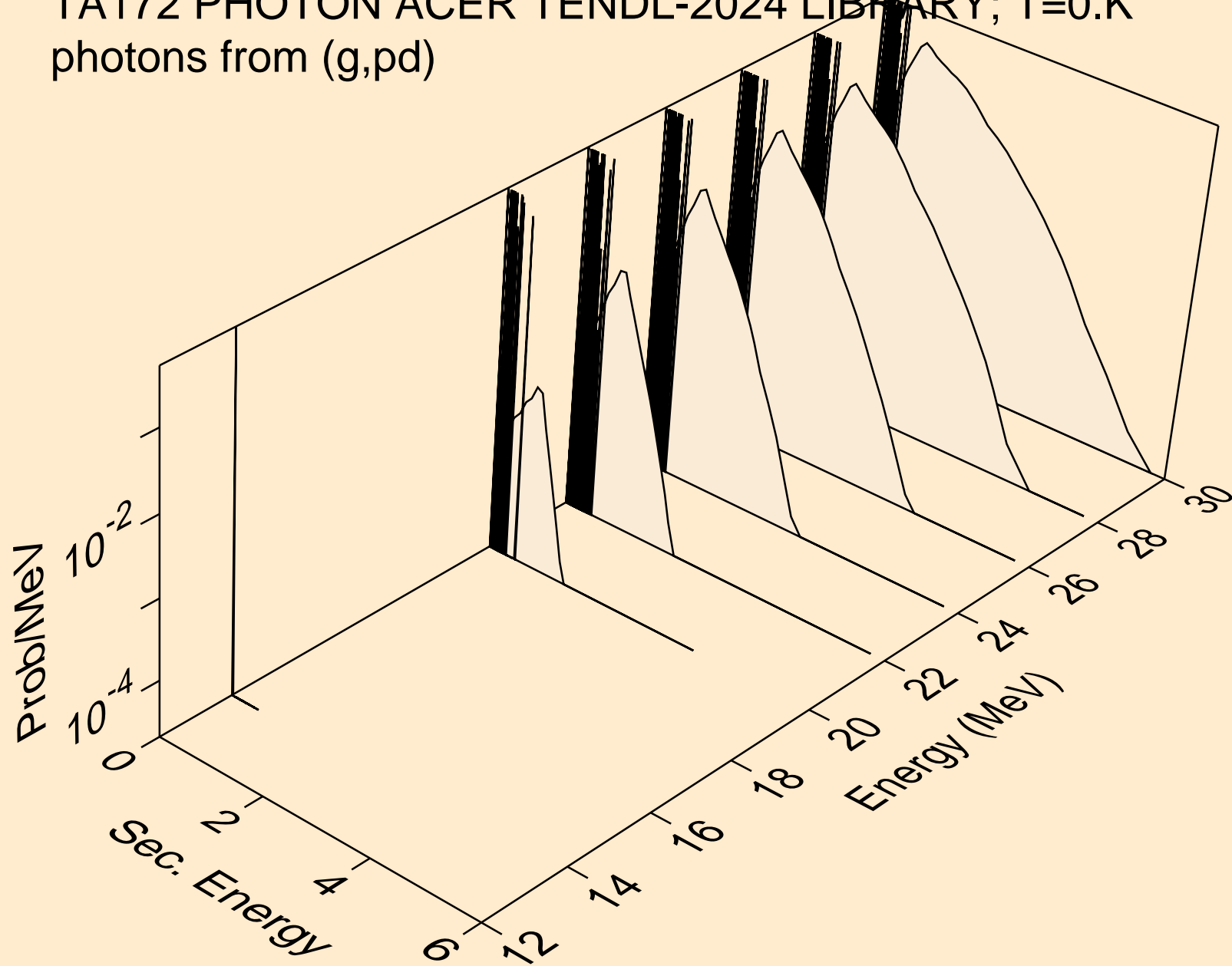

TA172 PHOTON ACER TENDL-2024 LIBRARY; T=0.K
photons from (g,da)

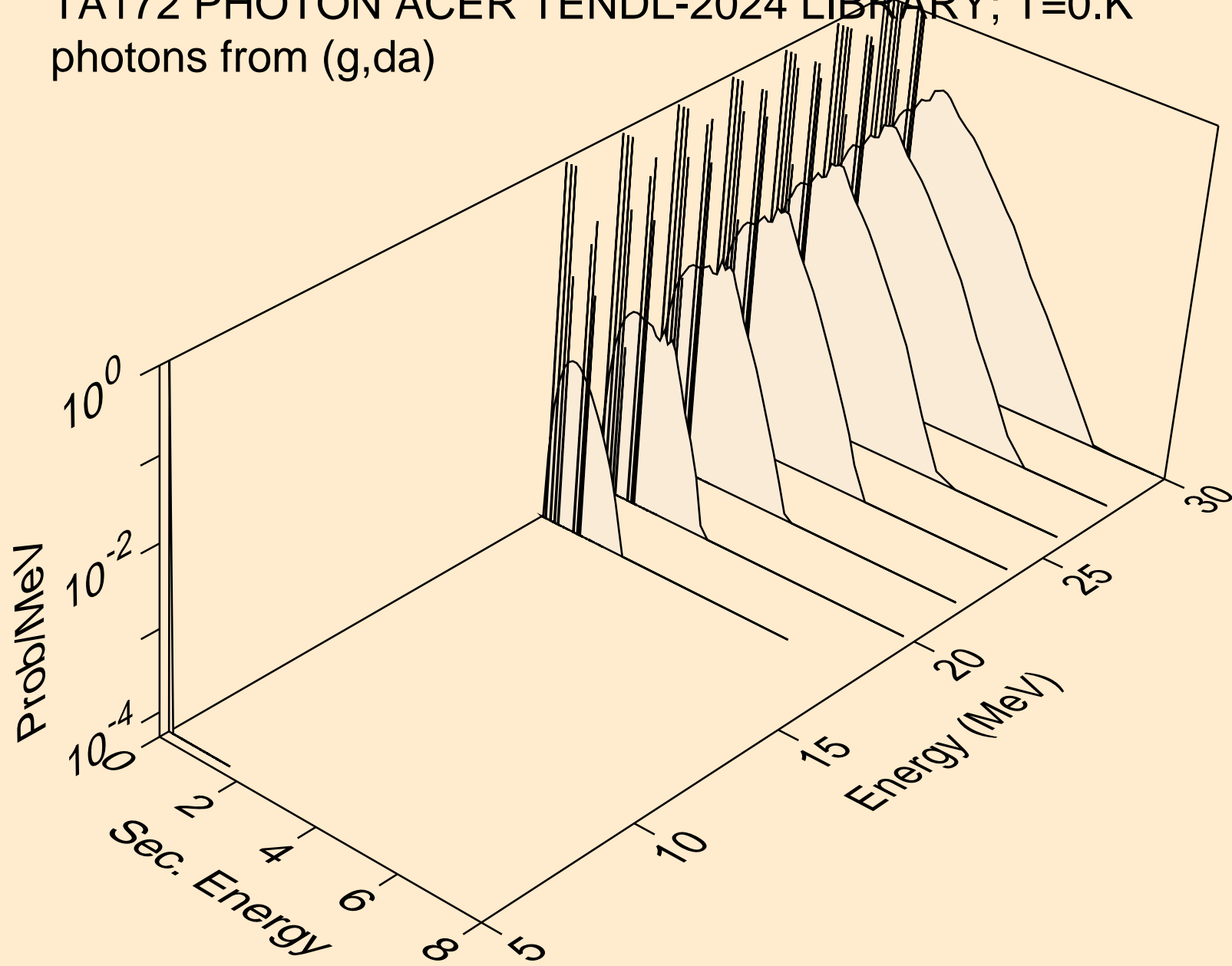

TA172 PHOTON ACER TENDL-2024 LIBRARY; T=0.K
protons from (g,x)

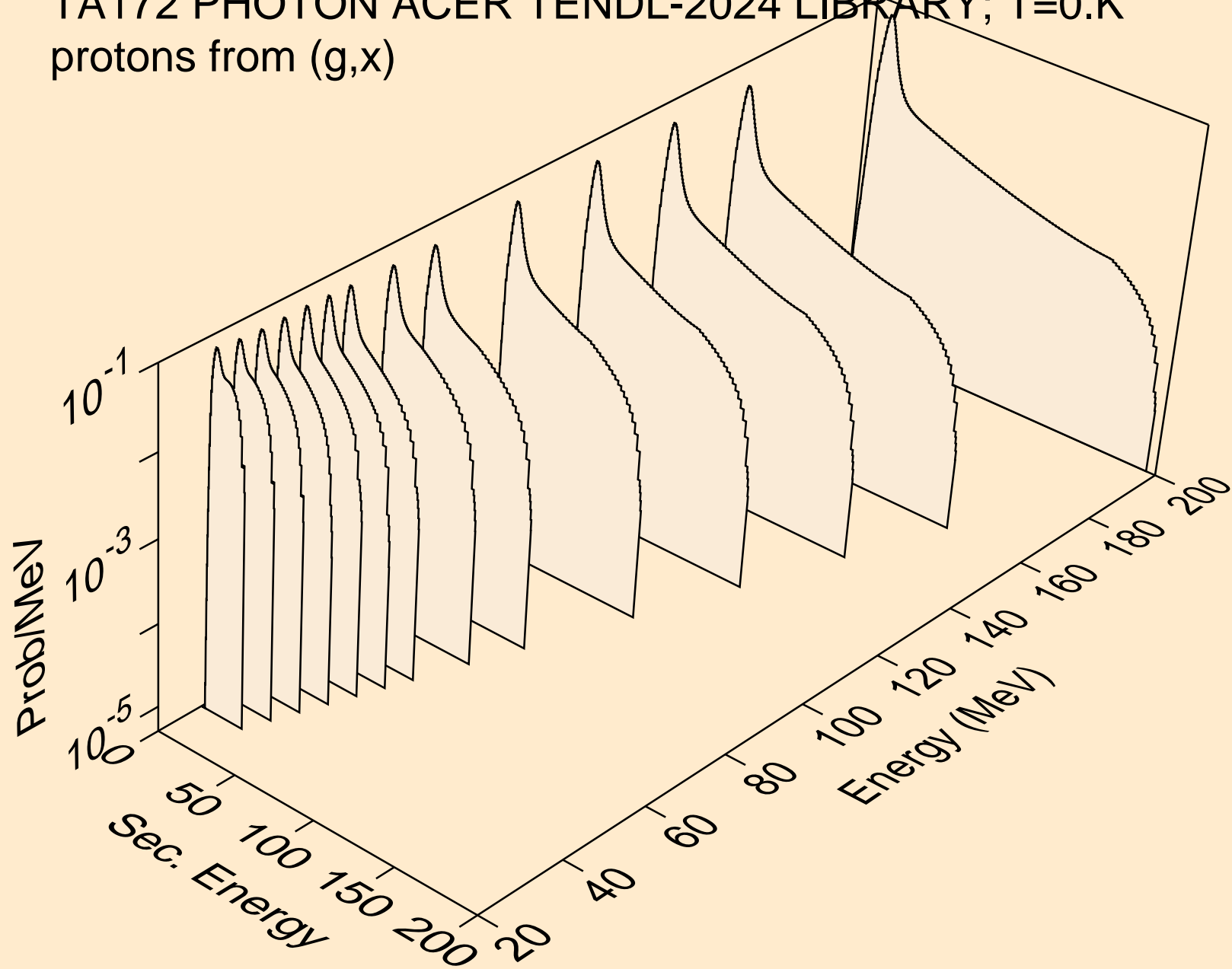

TA172 PHOTON ACER TENDL-2024 LIBRARY; T=0.K
protons from (g,n*)p

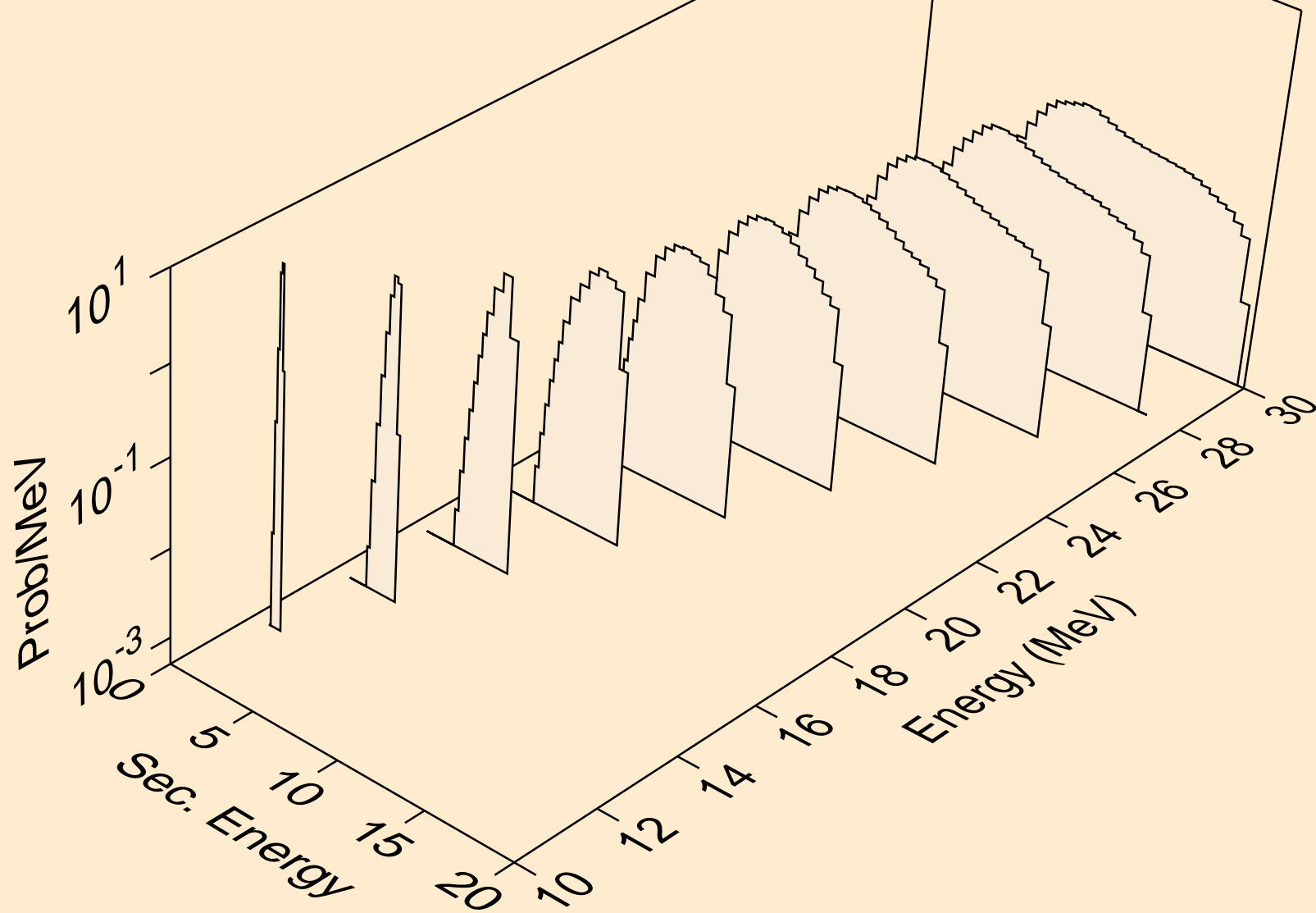

TA172 PHOTON ACER TENDL-2024 LIBRARY; T=0.K
protons from (g,2np)

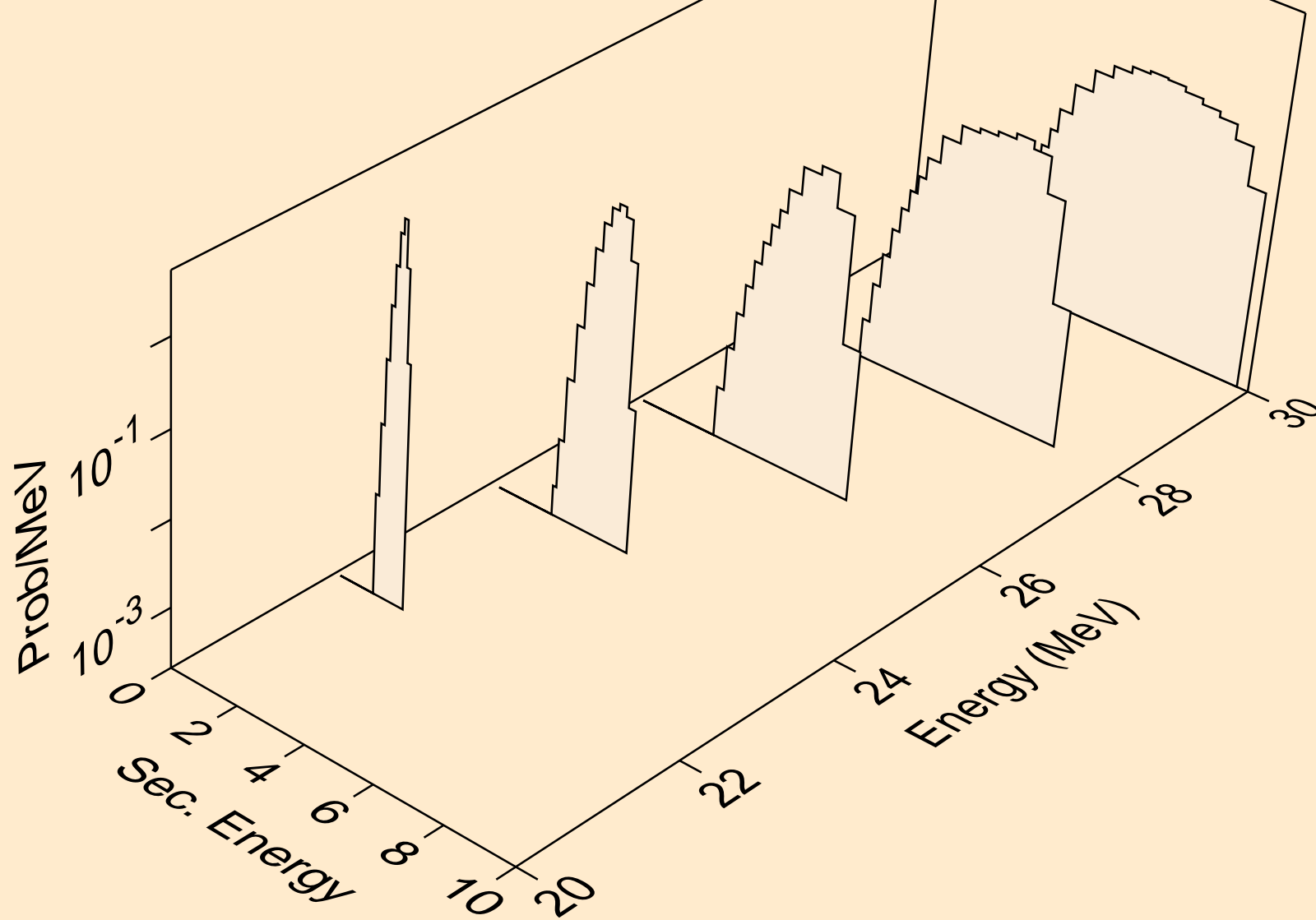

TA172 PHOTON ACER TENDL-2024 LIBRARY; T=0.K
protons from (g,n2p)

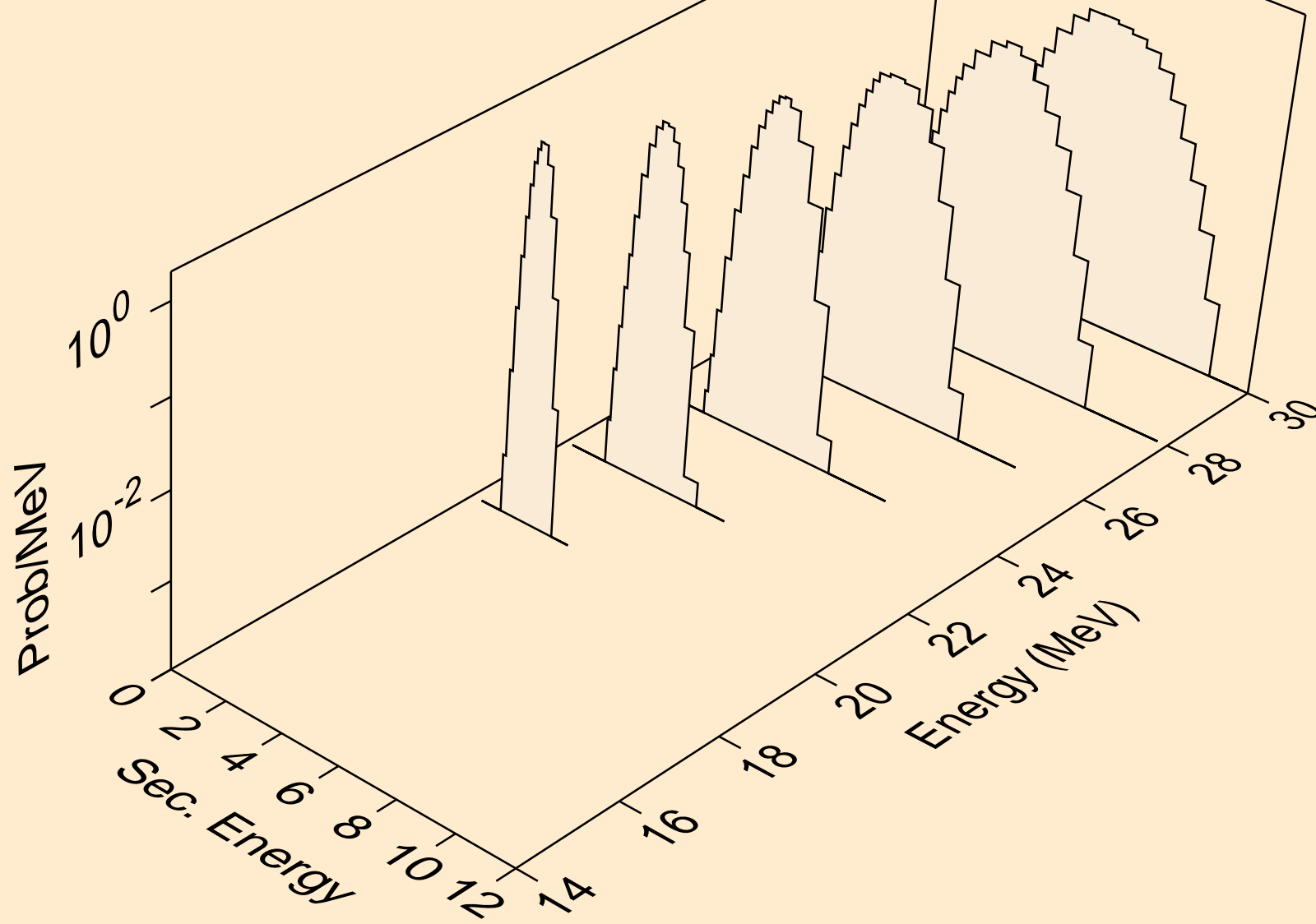

TA172 PHOTON ACER TENDL-2024 LIBRARY; T=0.K
protons from (g,npa)

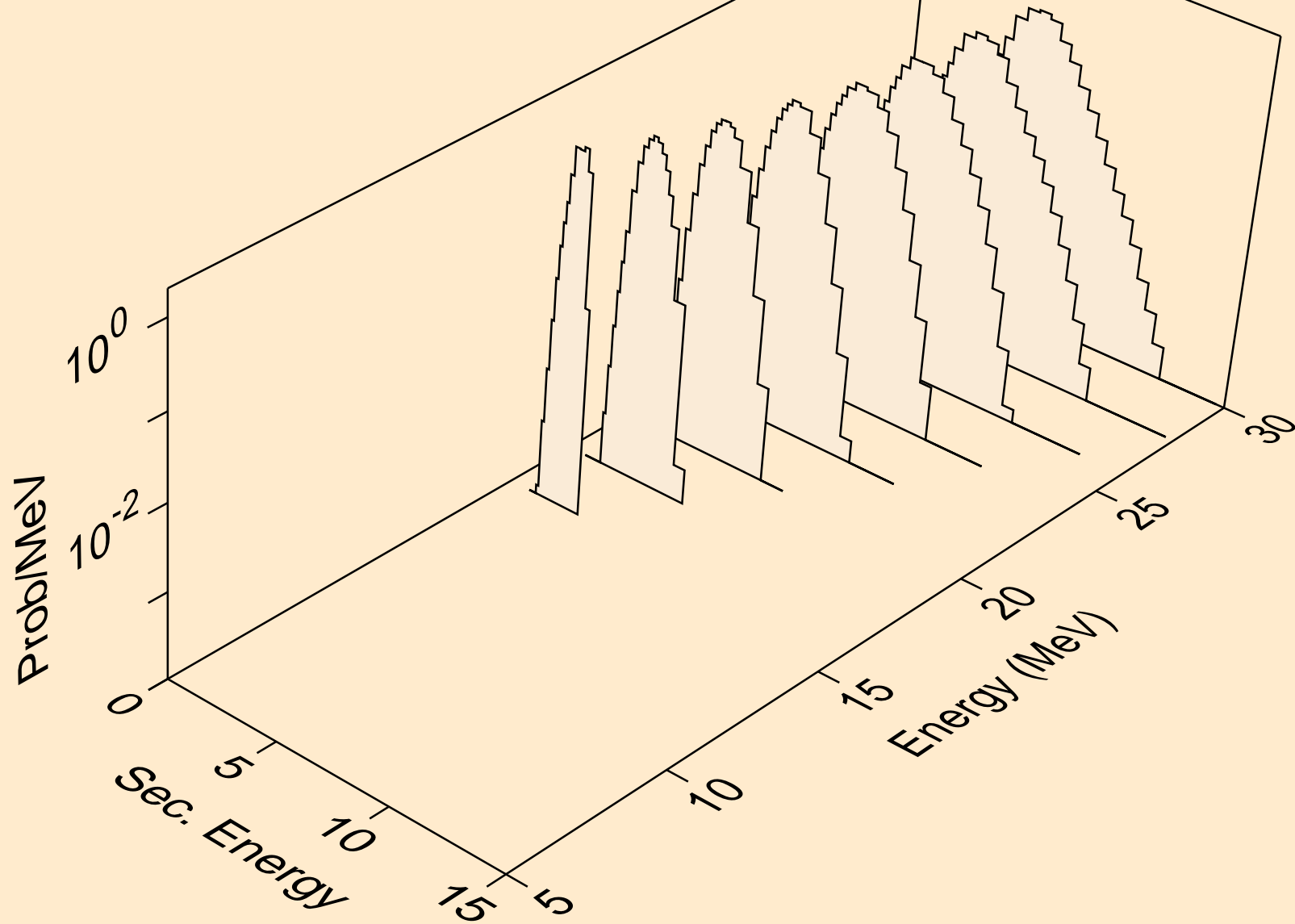

TA172 PHOTON ACER TENDL-2024 LIBRARY; T=0.K
protons from (g,p)

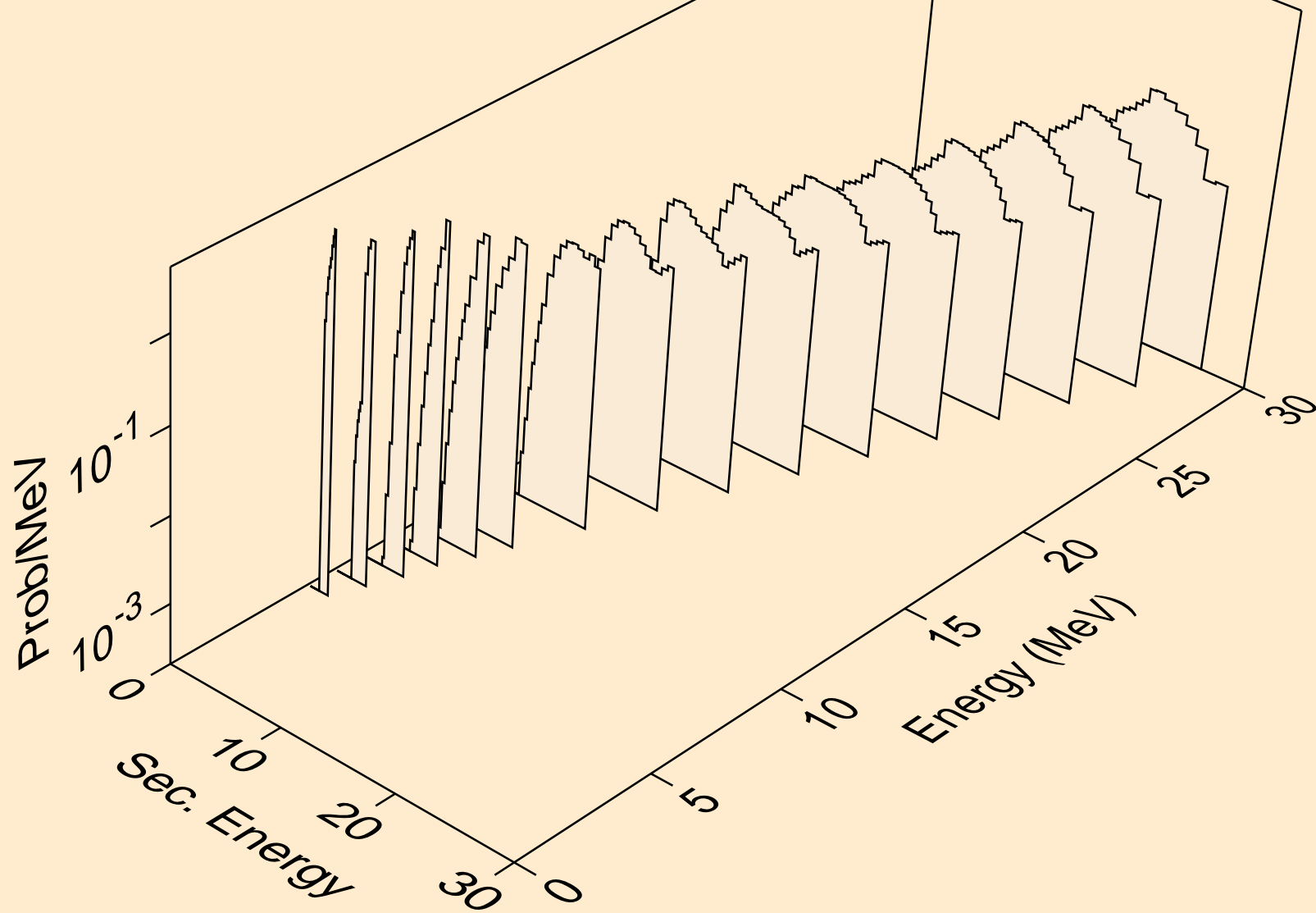

TA172 PHOTON ACER TENDL-2024 LIBRARY; T=0.K
protons from (g,2p)

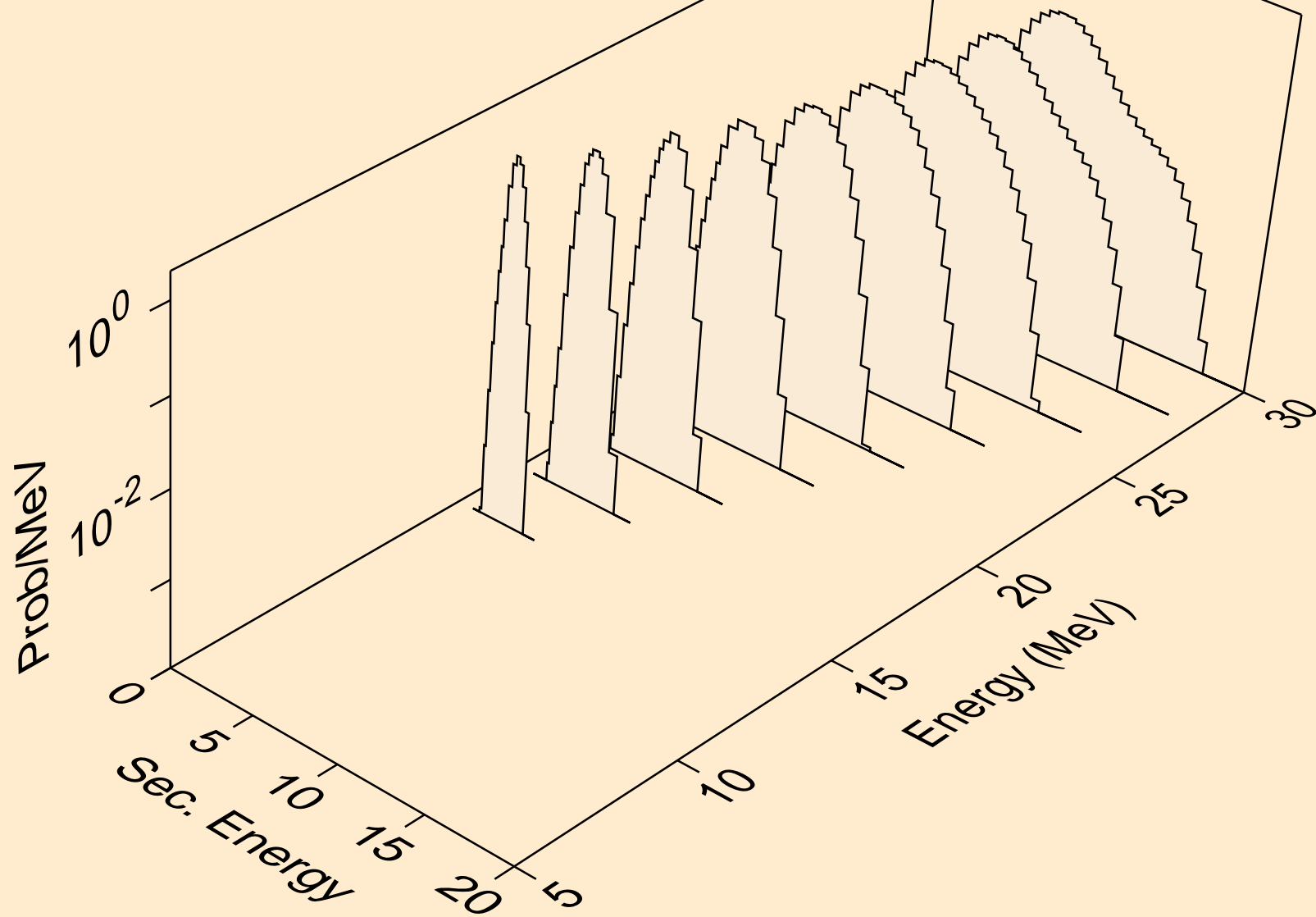

TA172 PHOTON ACER TENDL-2024 LIBRARY; T=0.K
protons from (g,pa)

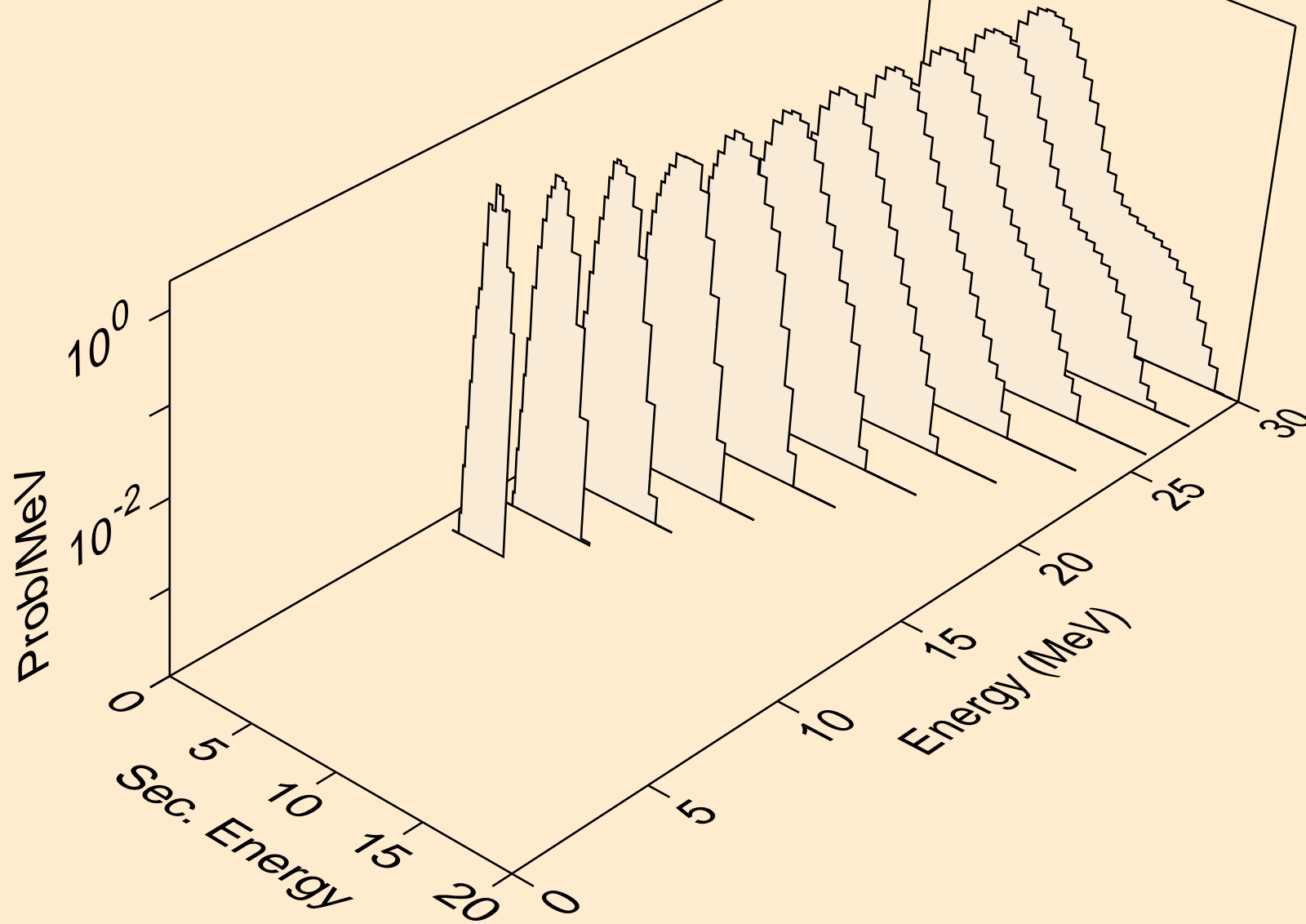

TA172 PHOTON ACER TENDL-2024 LIBRARY; T=0.K
protons from (g,pd)

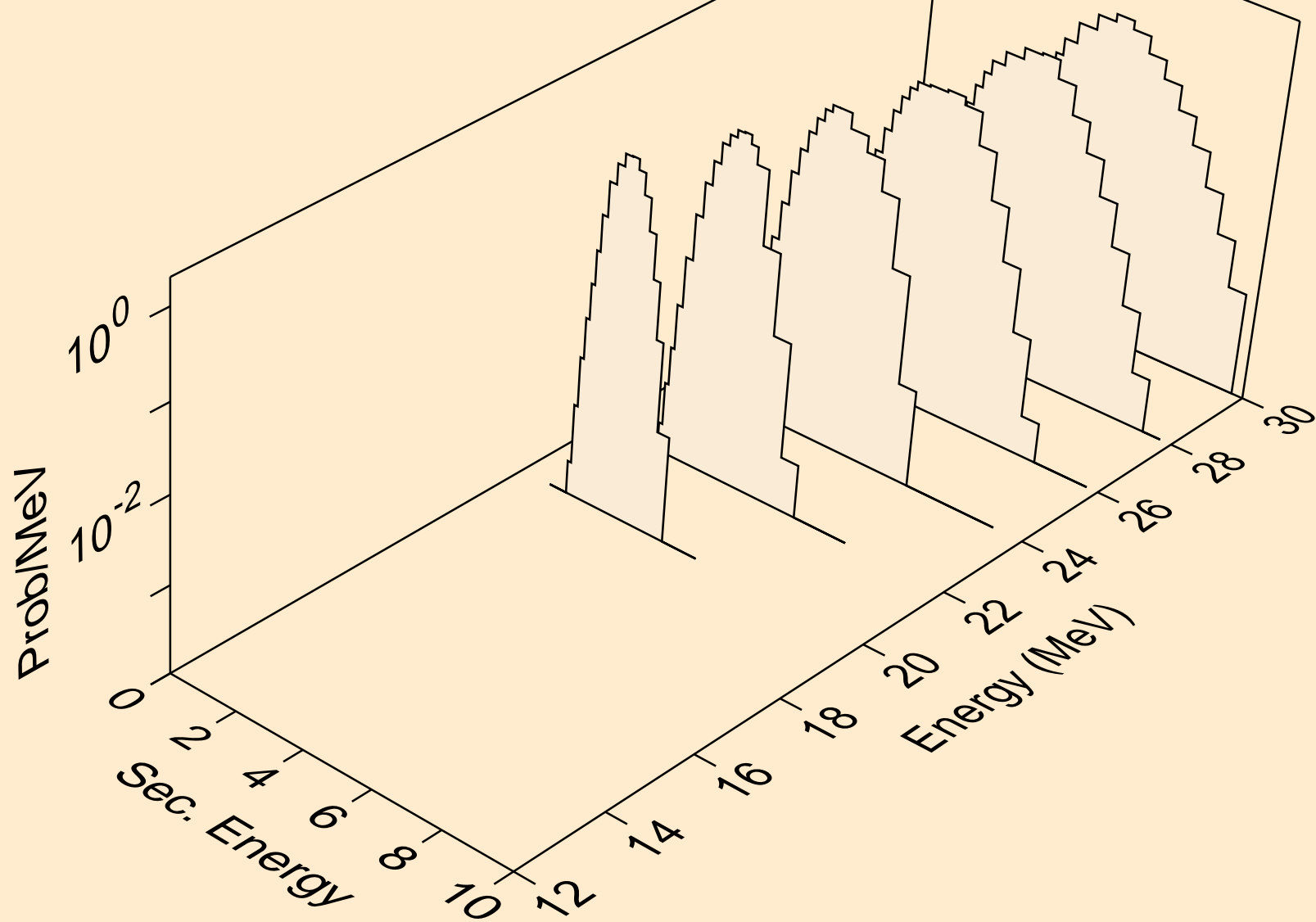

TA172 PHOTON ACER TENDL-2024 LIBRARY; T=0.K
deuterons from (g,x)

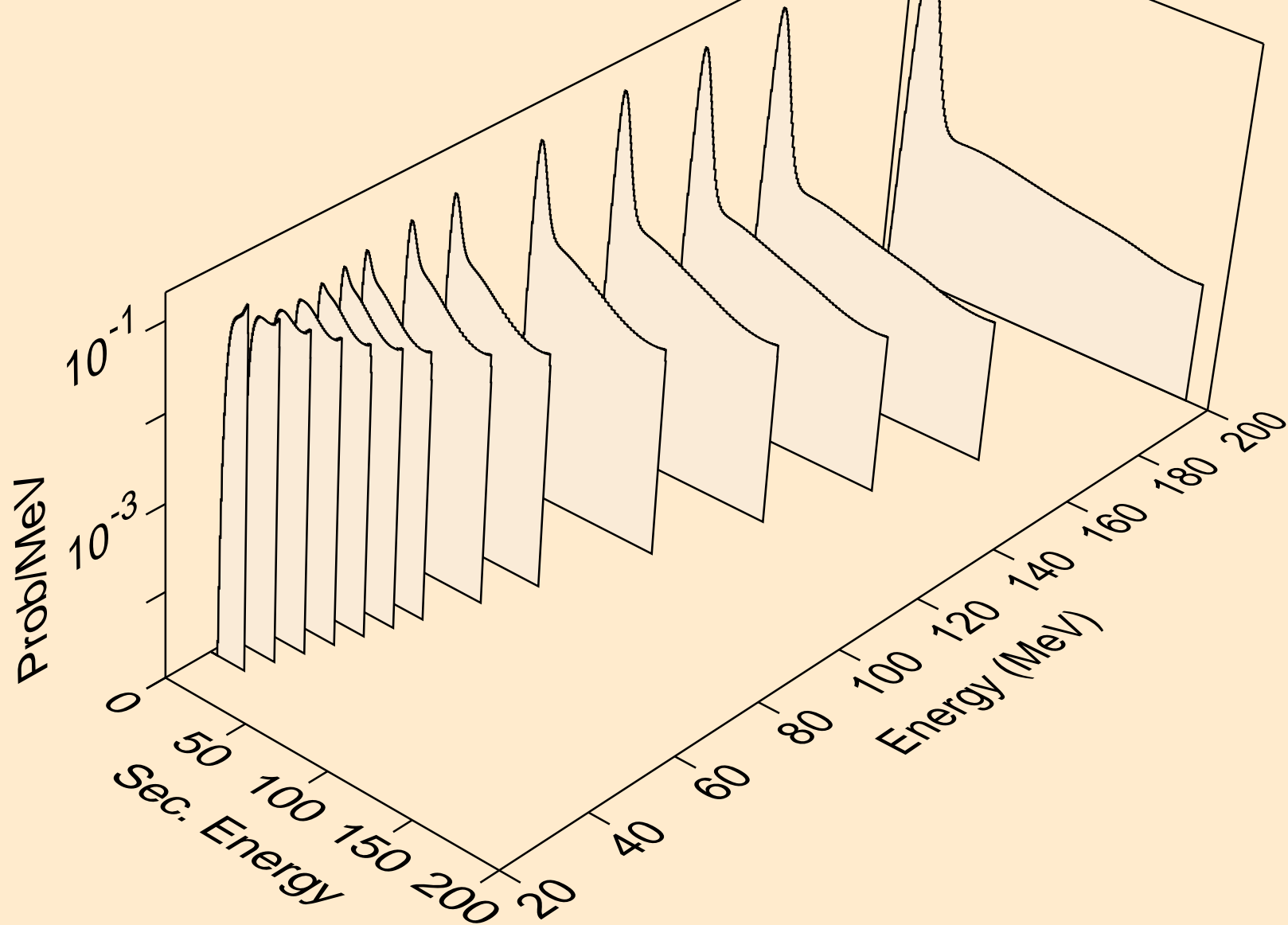

TA172 PHOTON ACER TENDL-2024 LIBRARY; T=0.K
deuterons from (g,n*)d

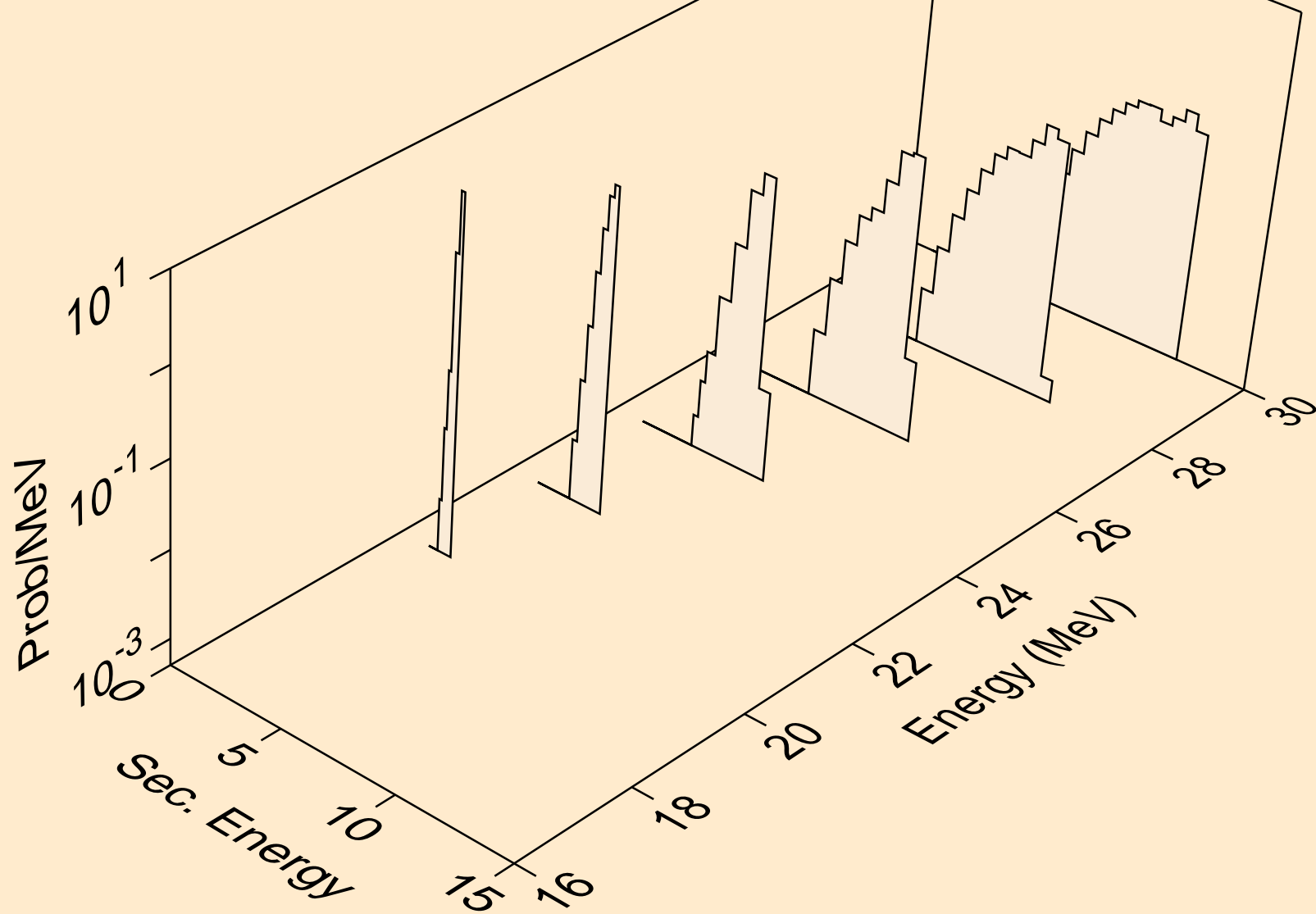

TA172 PHOTON ACER TENDL-2024 LIBRARY; T=0.K
deuterons from (g,d)

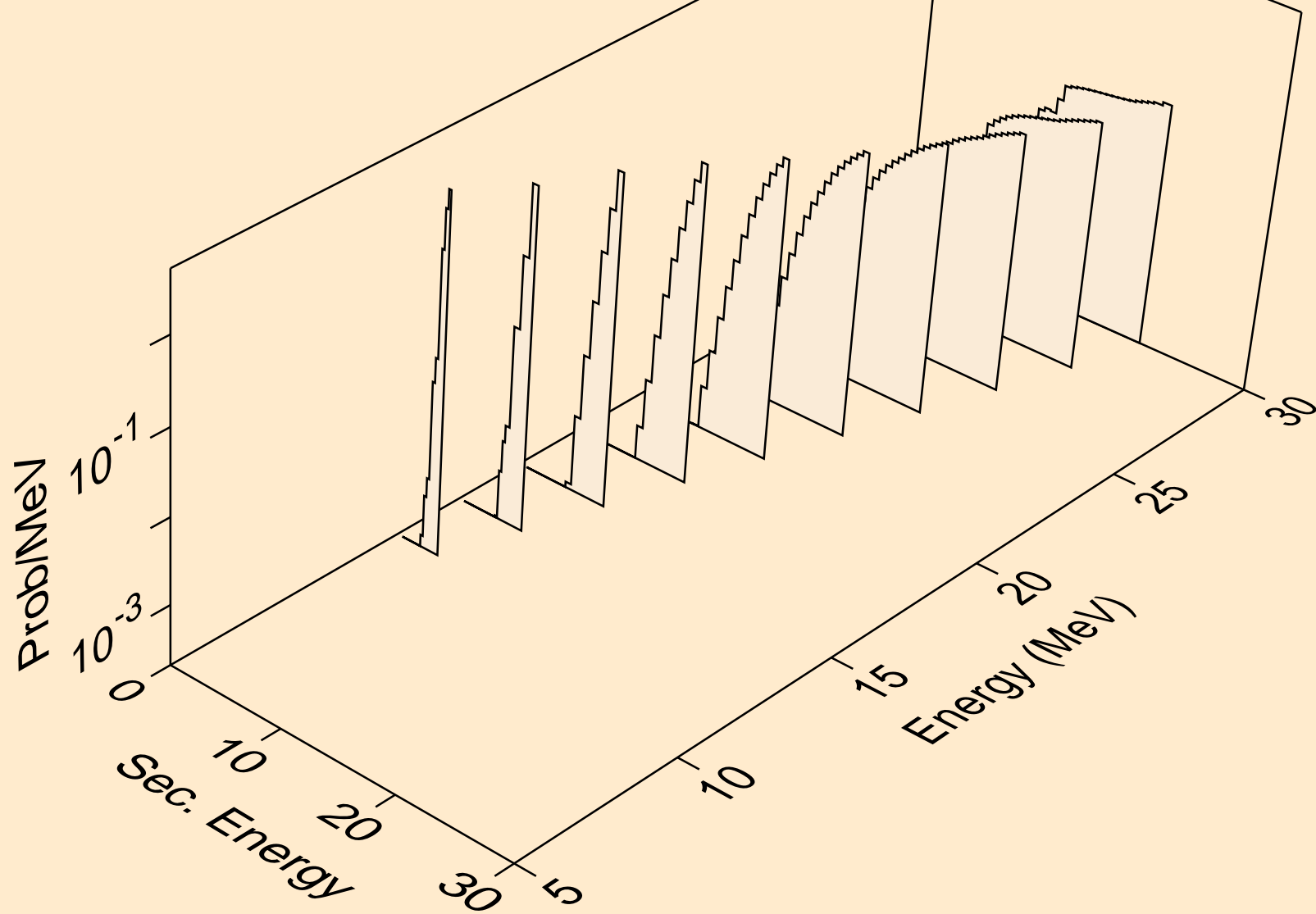

TA172 PHOTON ACER TENDL-2024 LIBRARY; T=0.K
deuterons from (g,pd)

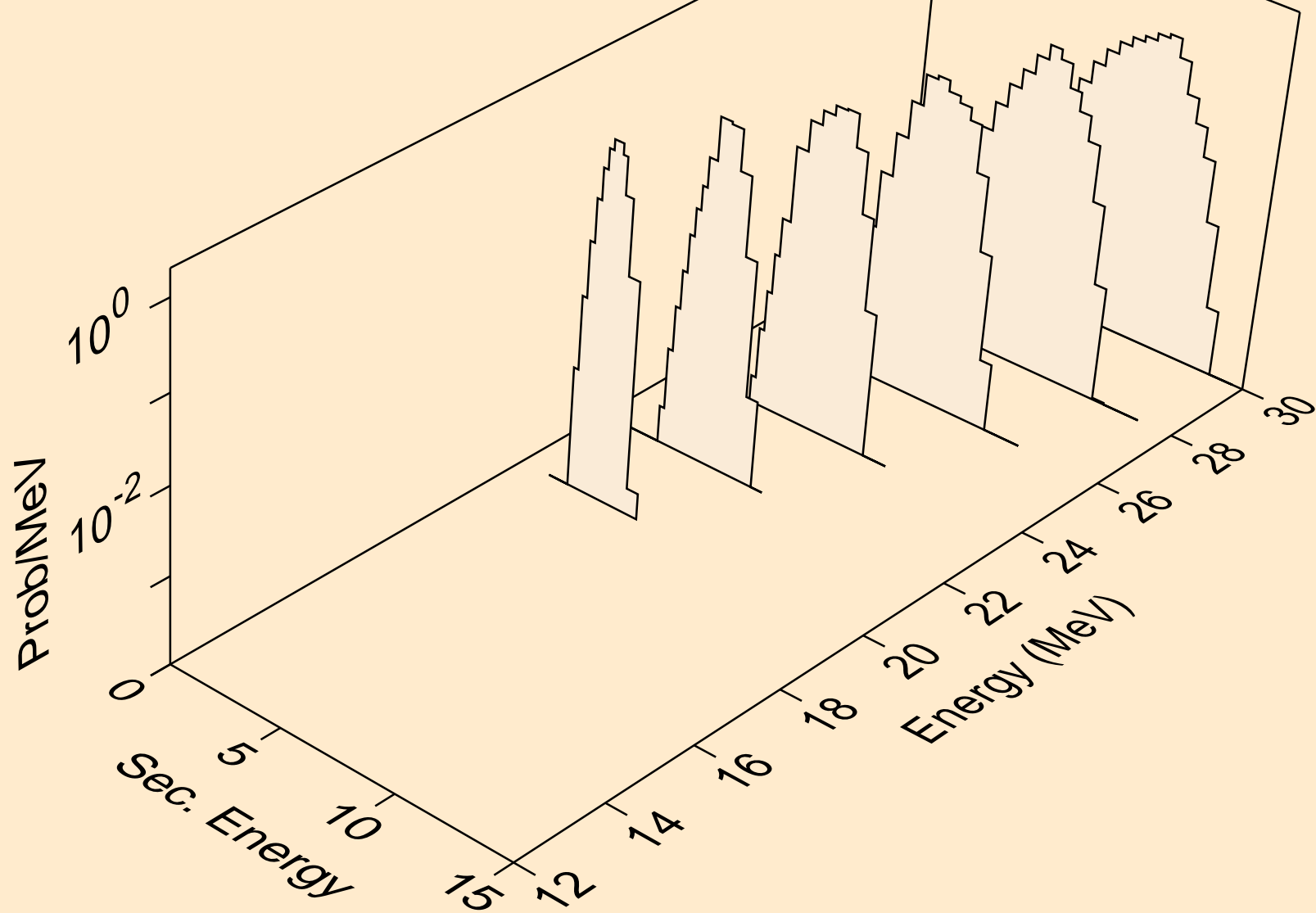

TA172 PHOTON ACER TENDL-2024 LIBRARY; T=0.K
deuterons from (g,da)

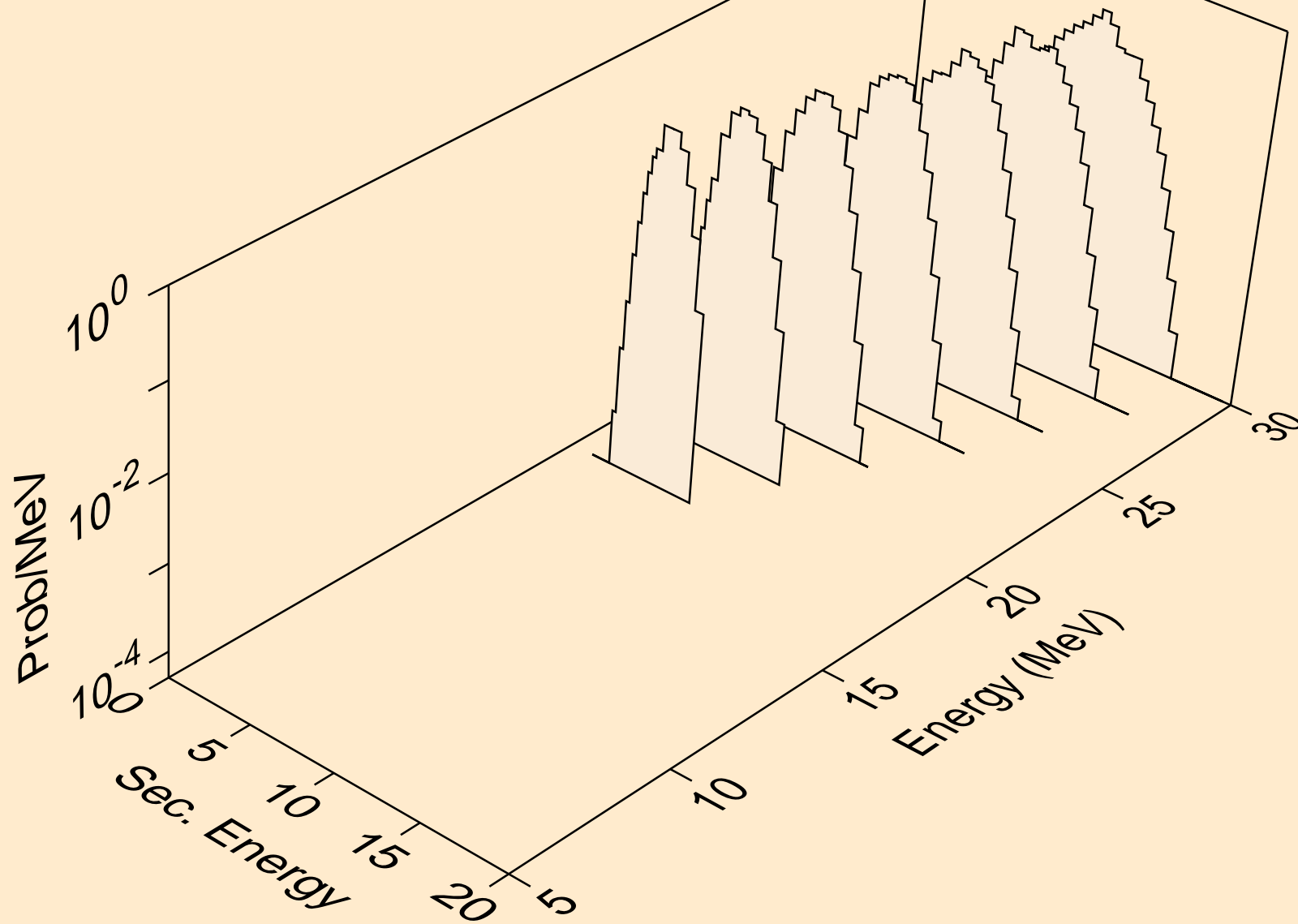

TA172 PHOTON ACER TENDL-2024 LIBRARY; T=0.K
tritons from (g,x)

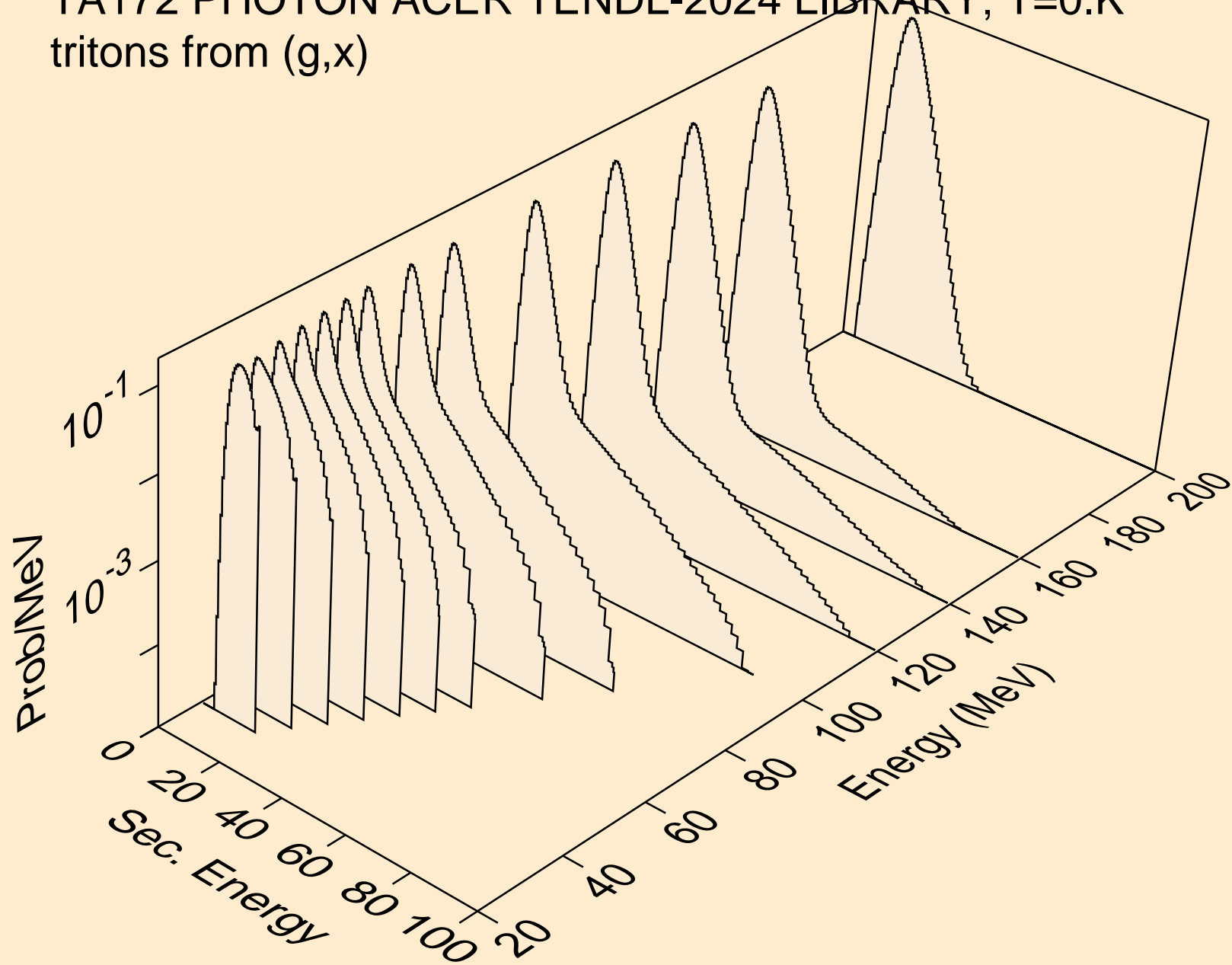

TA172 PHOTON ACER TENDL-2024 LIBRARY; T=0.K
tritons from (g,n*)t

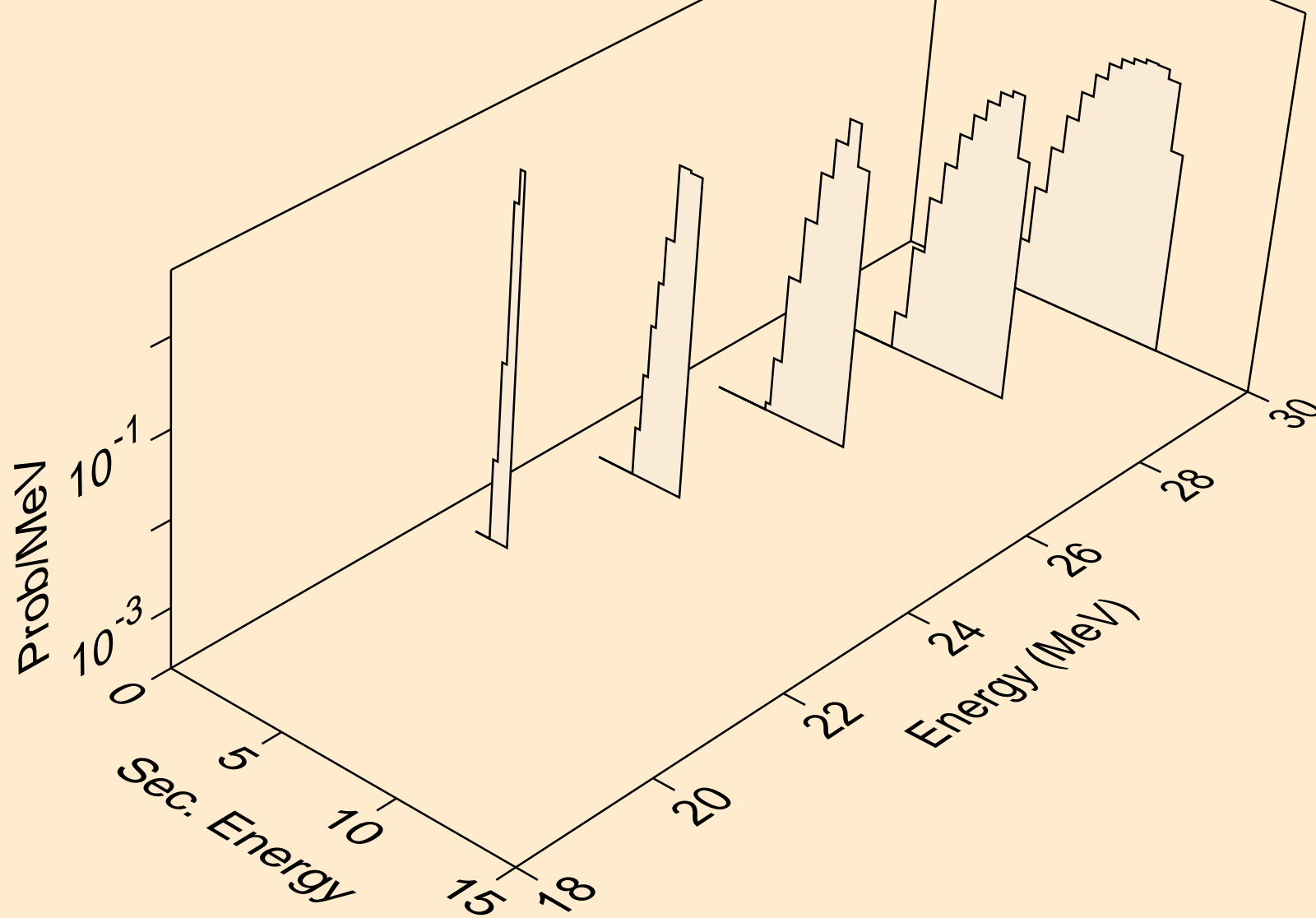

TA172 PHOTON ACER TENDL-2024 LIBRARY; T=0.K
tritons from (g,t)

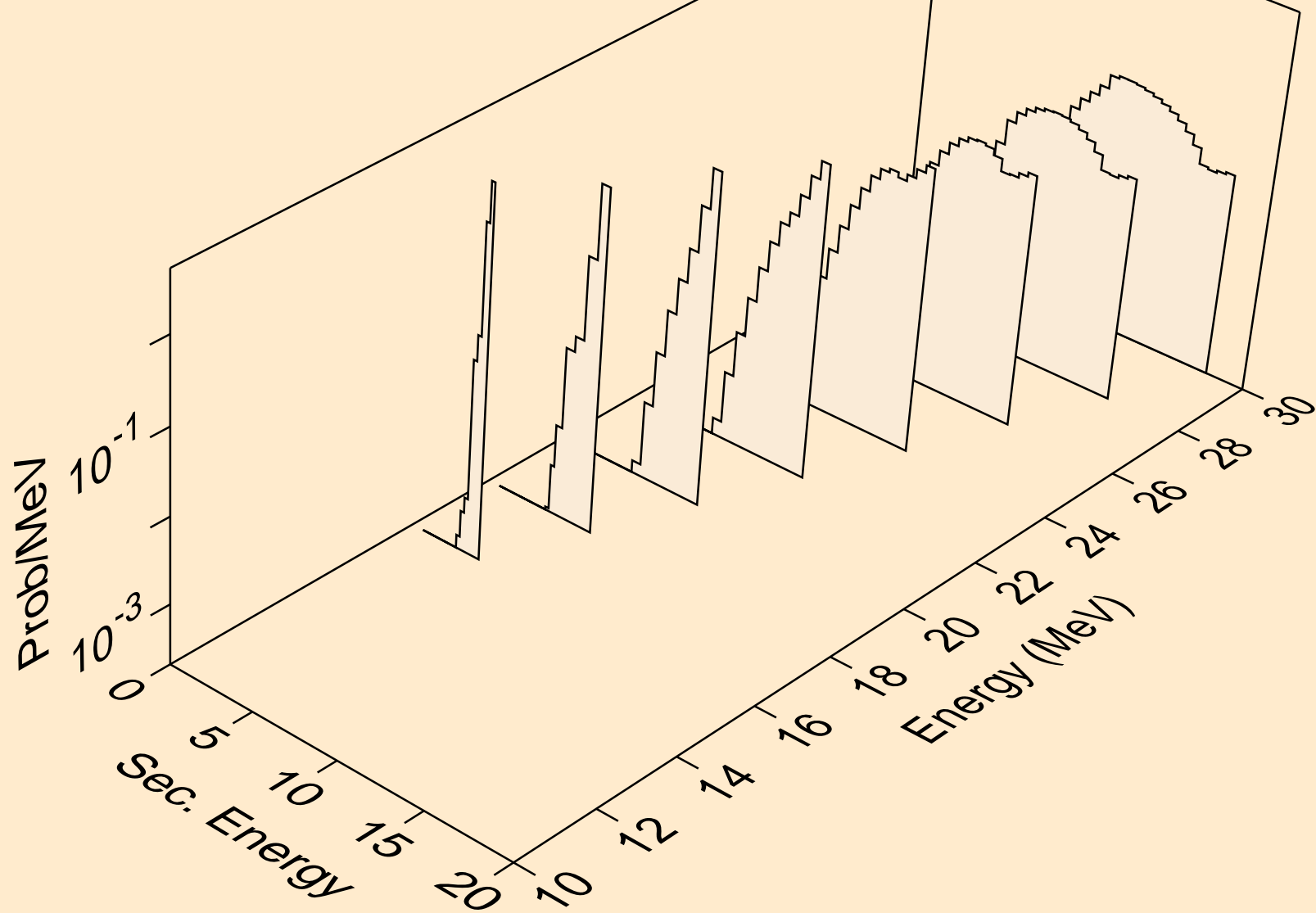

TA172 PHOTON ACER TENDL-2024 LIBRARY; T=0.K
he3s from (g,x)

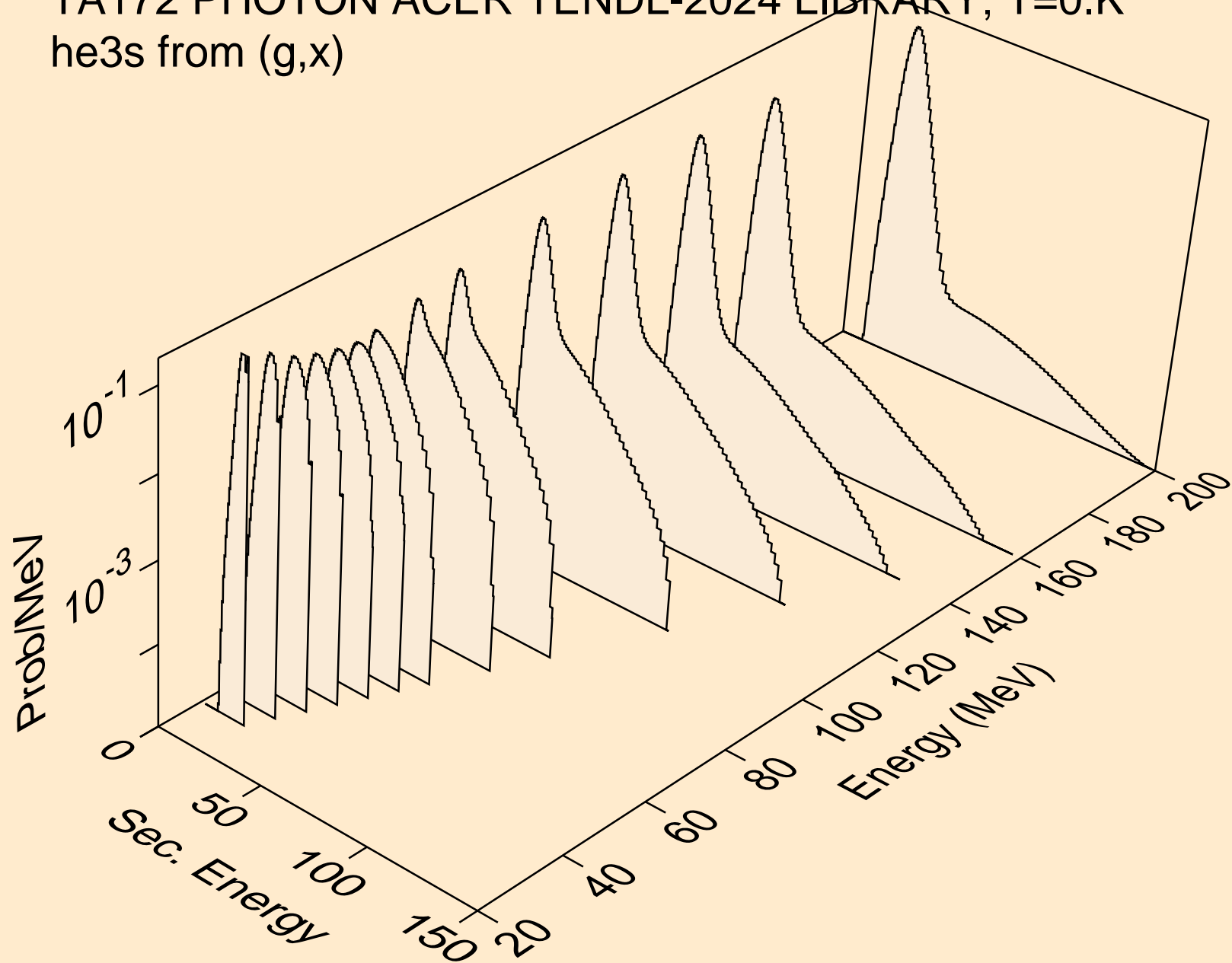

TA172 PHOTON ACER TENDL-2024 LIBRARY; T=0.K
he3s from (g,he3)

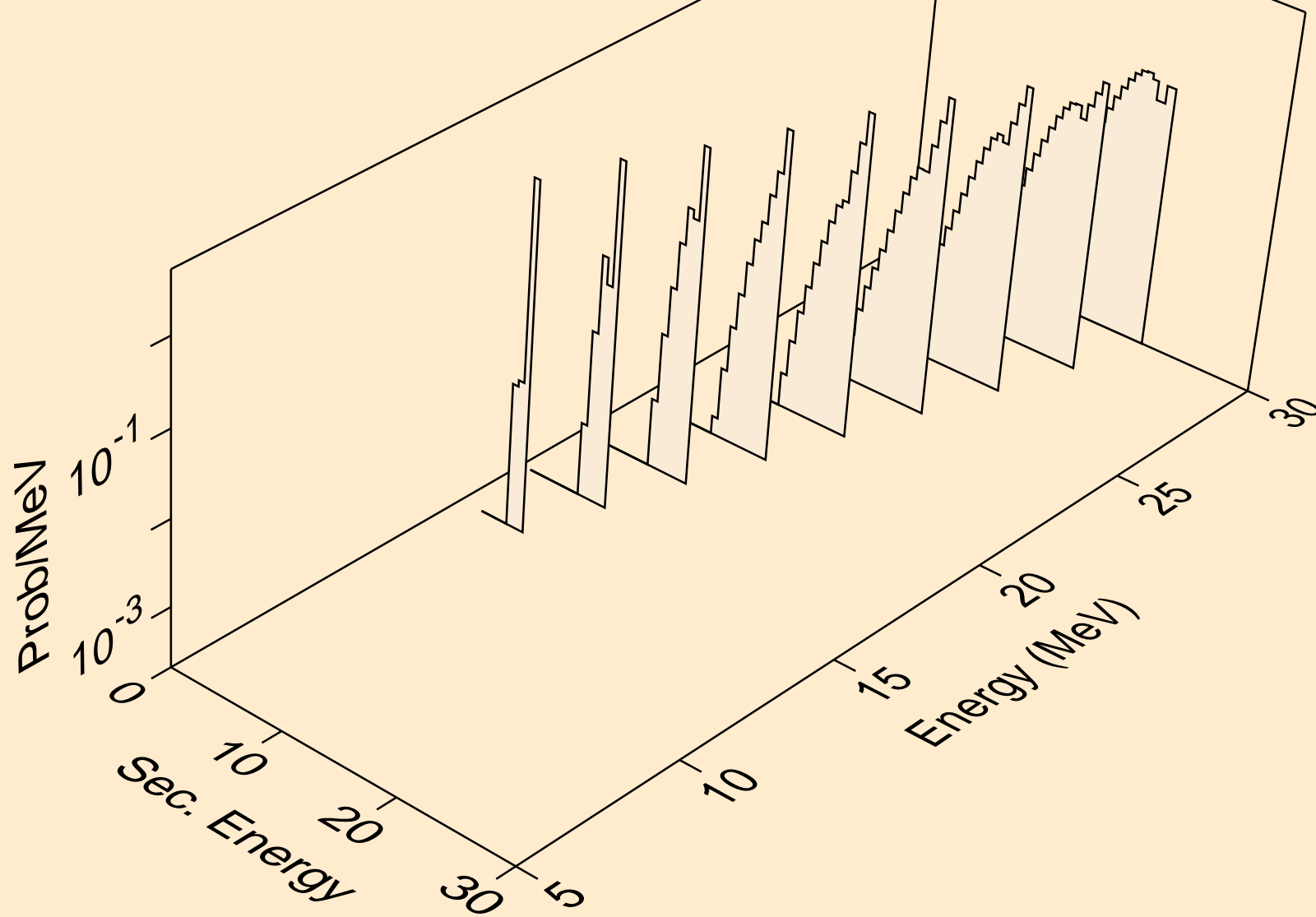

TA172 PHOTON ACER TENDL-2024 LIBRARY; T=0.K
alphas from (g,x)

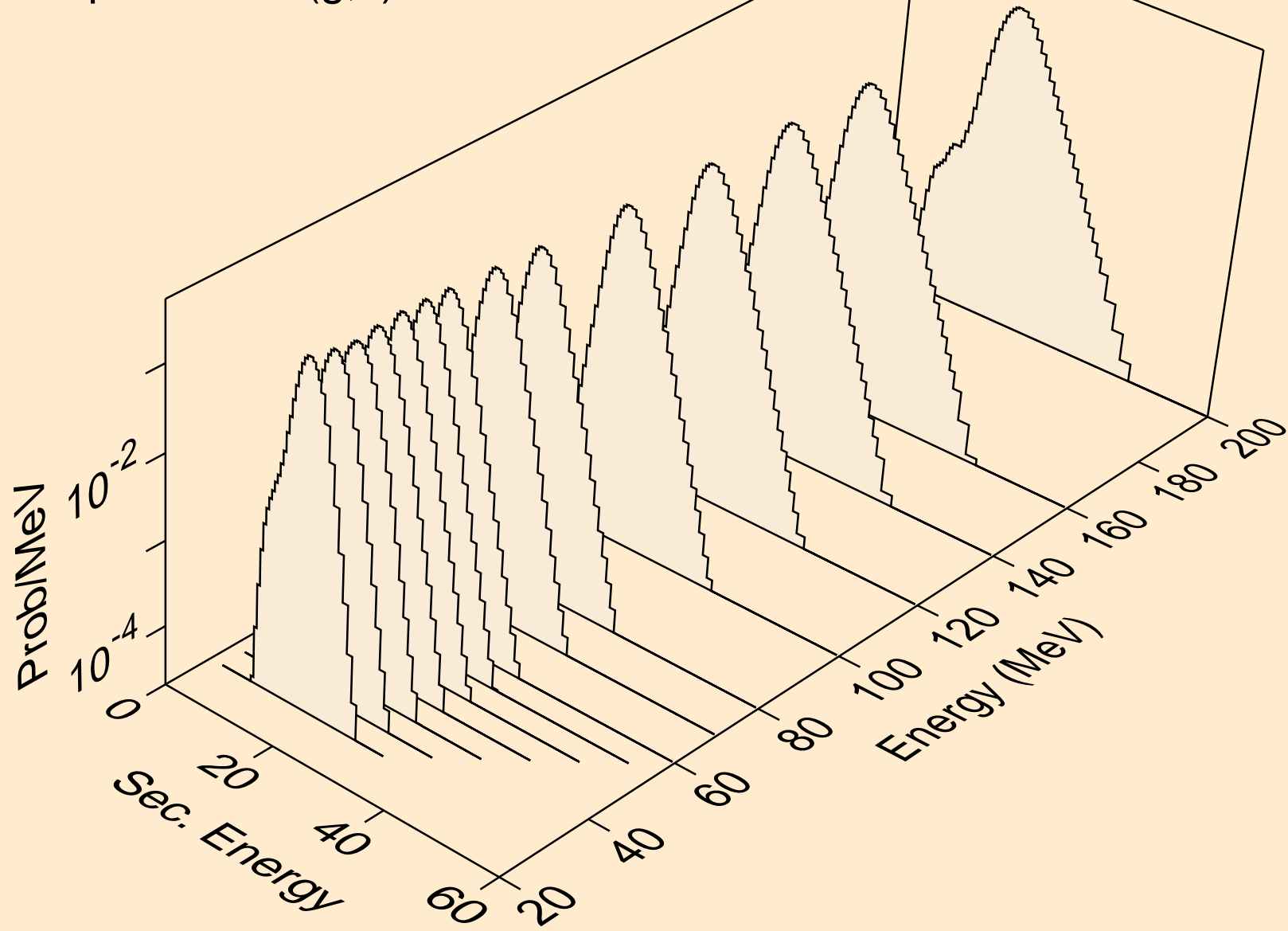

TA172 PHOTON ACER TENDL-2024 LIBRARY; T=0.K
alphas from (g,n*)a

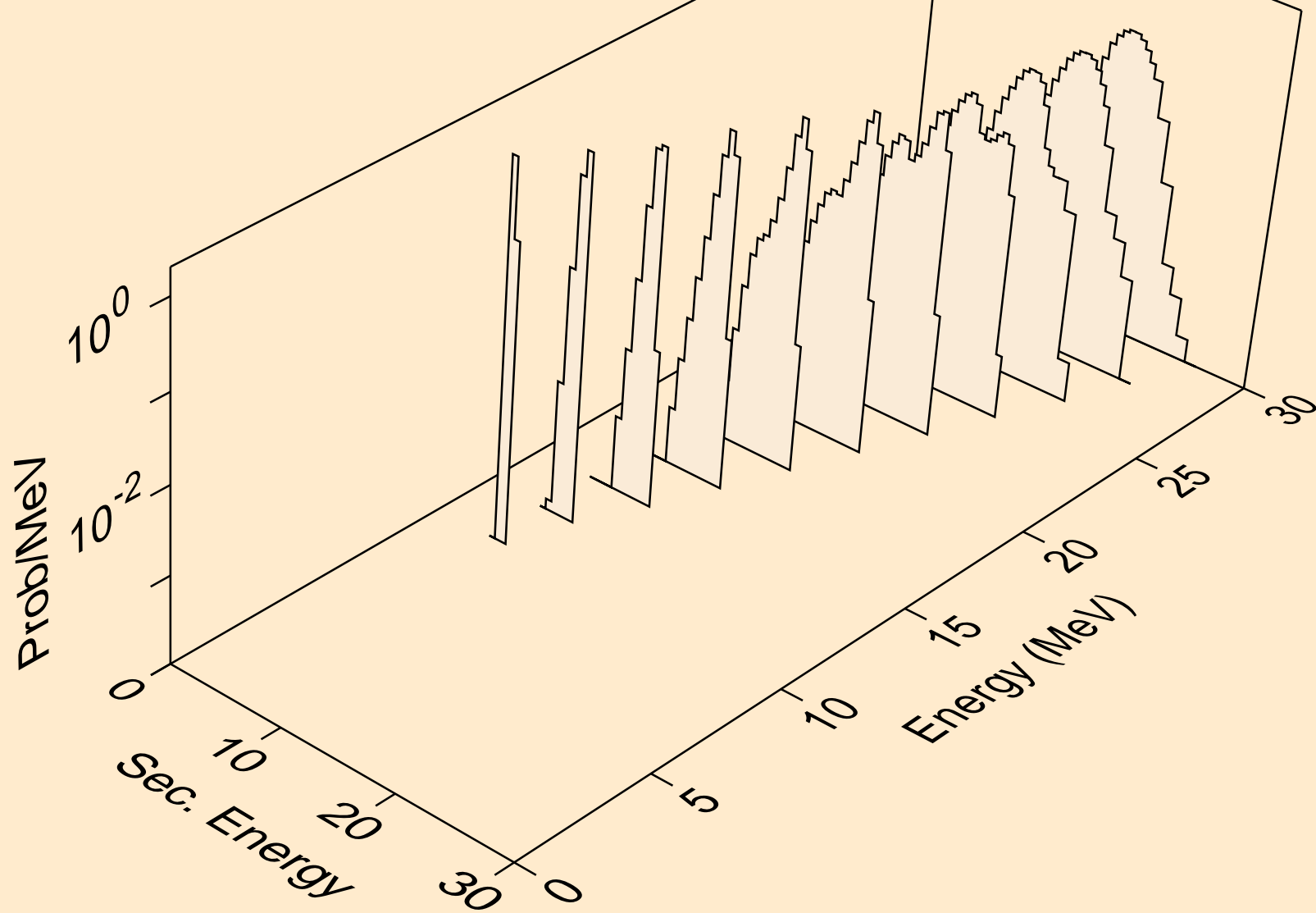

TA172 PHOTON ACER TENDL-2024 LIBRARY; T=0.K
alphas from (g,2n)a

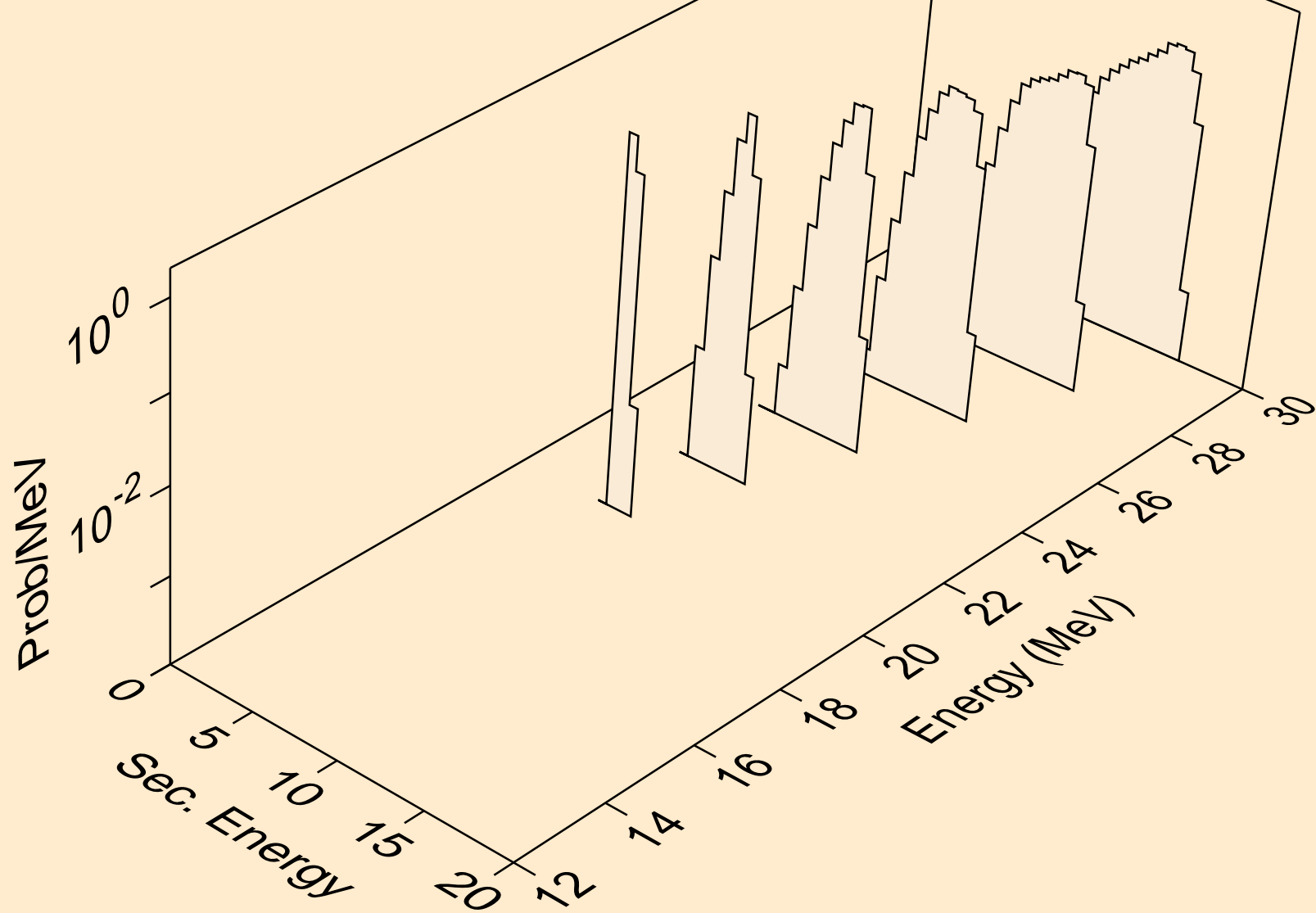

TA172 PHOTON ACER TENDL-2024 LIBRARY; T=0.K
alphas from (g,n*)2a

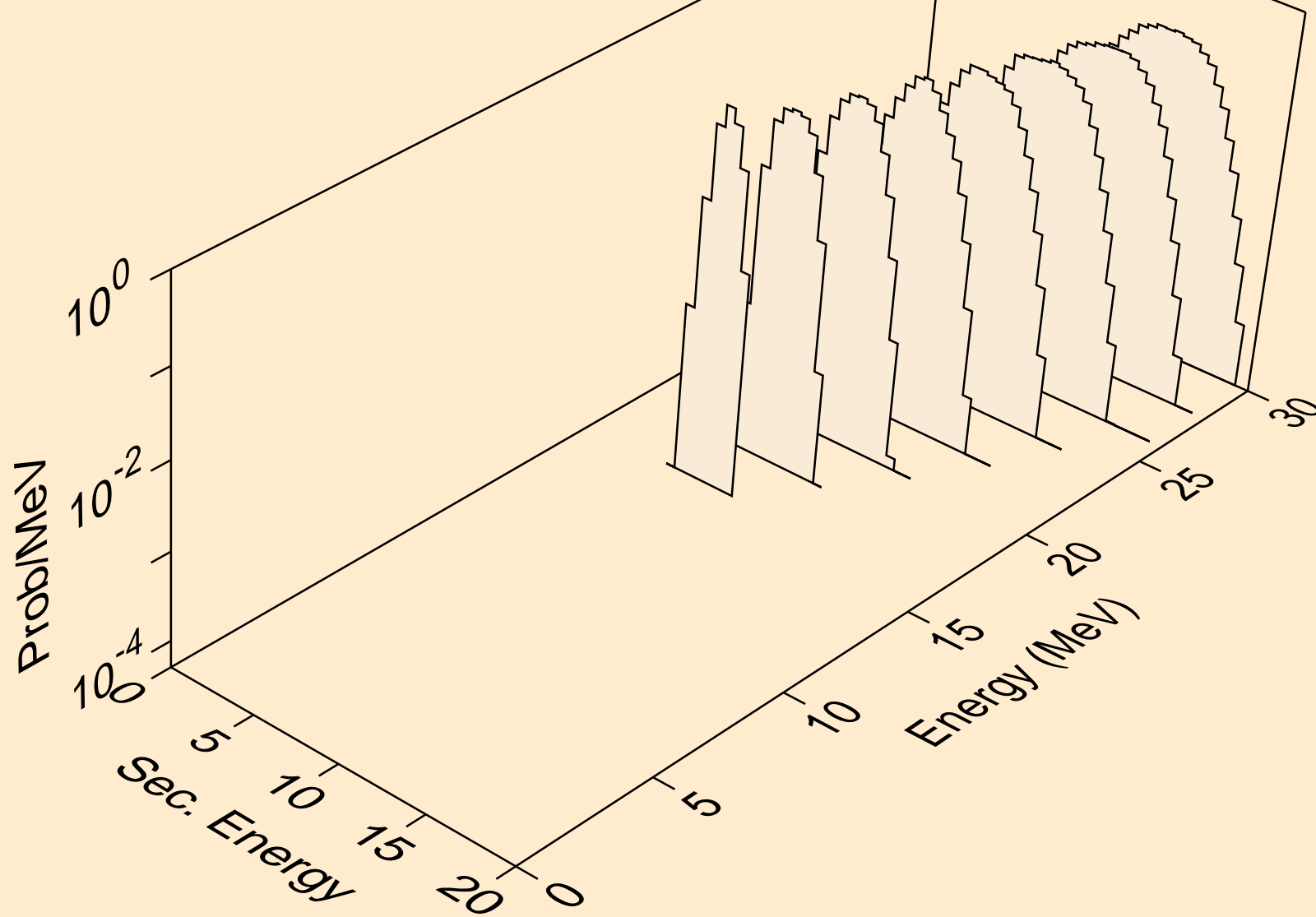

TA172 PHOTON ACER TENDL-2024 LIBRARY; T=0.K
alphas from (g,npa)

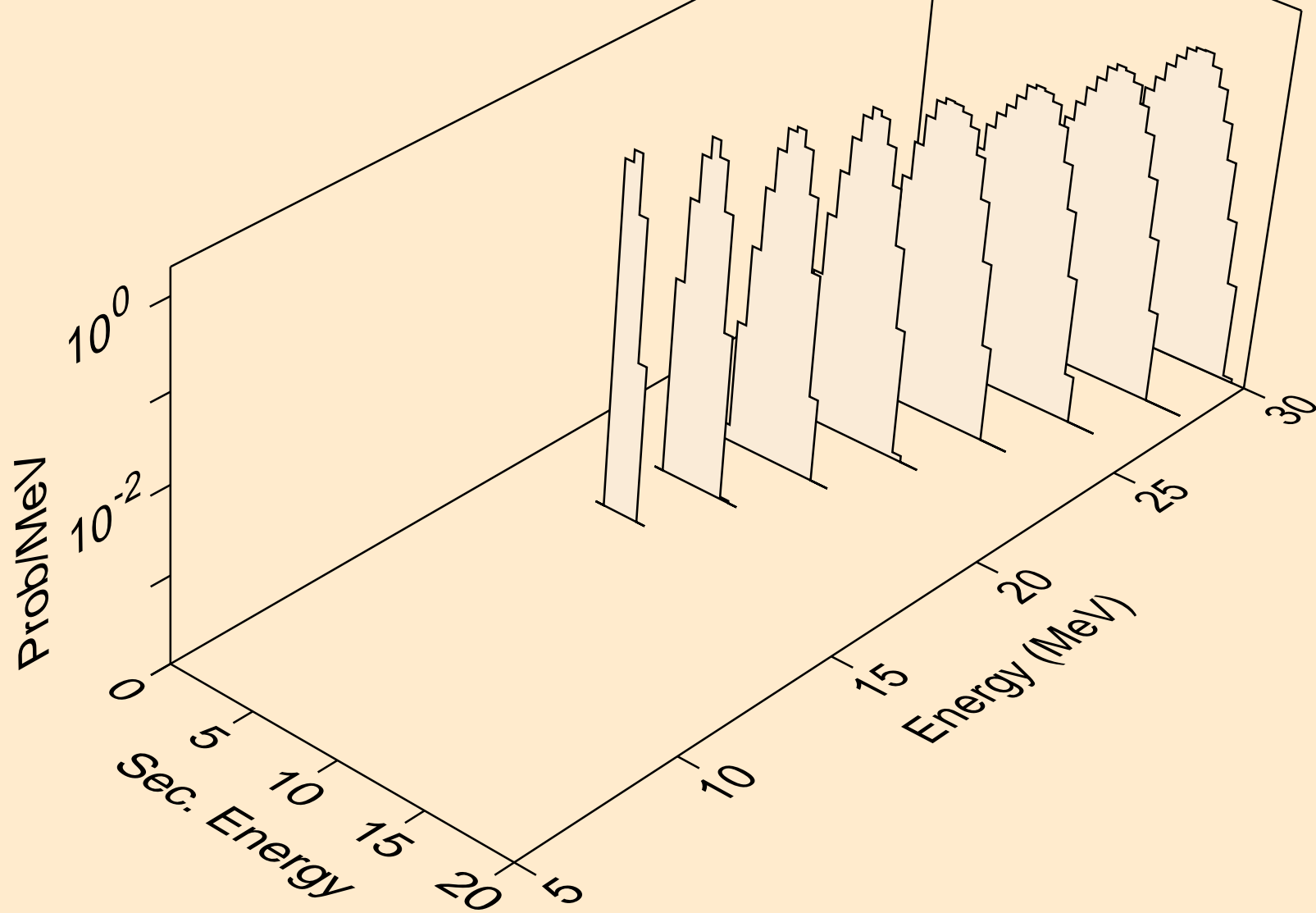

TA172 PHOTON ACER TENDL-2024 LIBRARY; T=0.K
alphas from (g,a)

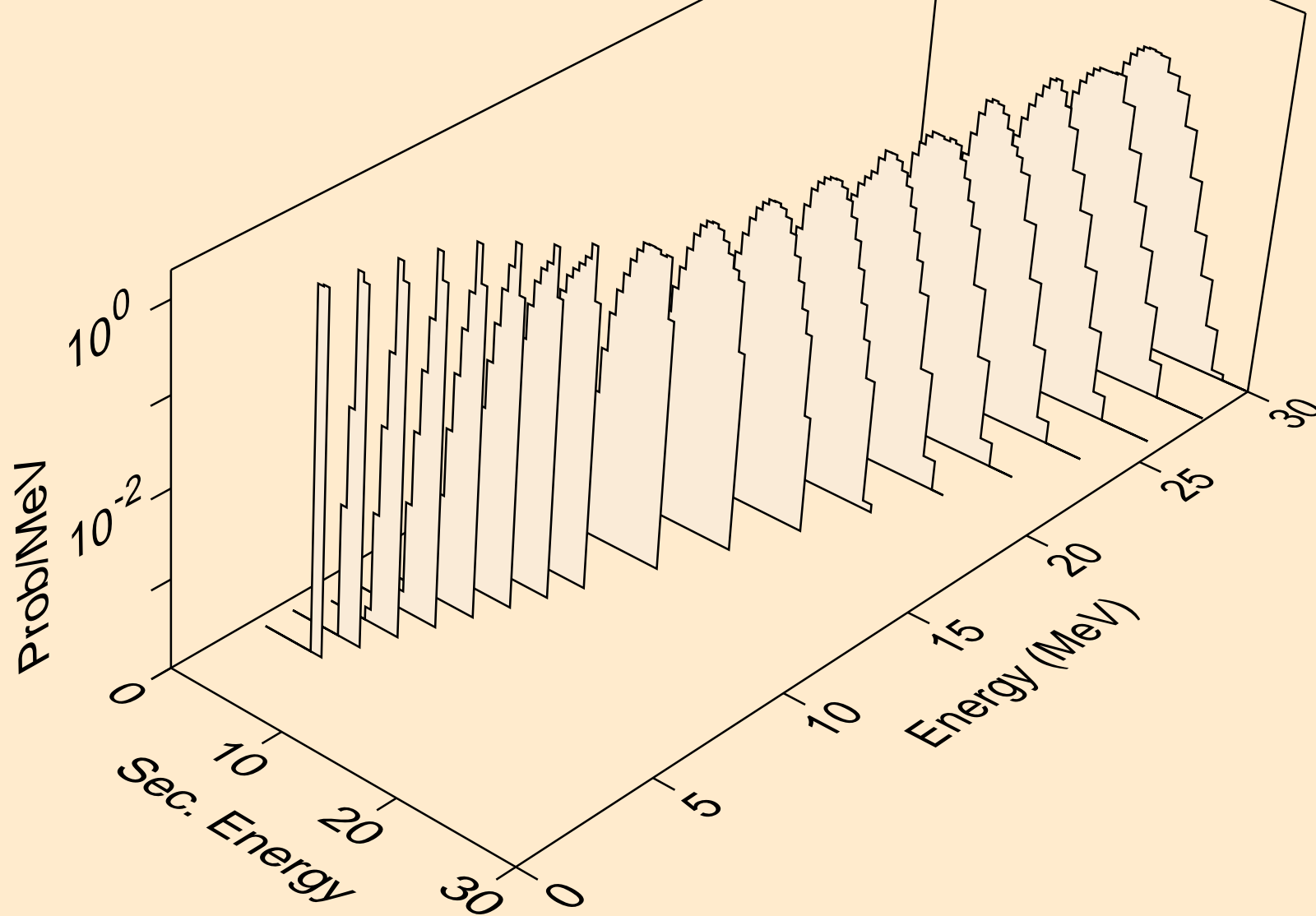

TA172 PHOTON ACER TENDL-2024 LIBRARY; T=0.K
alphas from (g,2a)

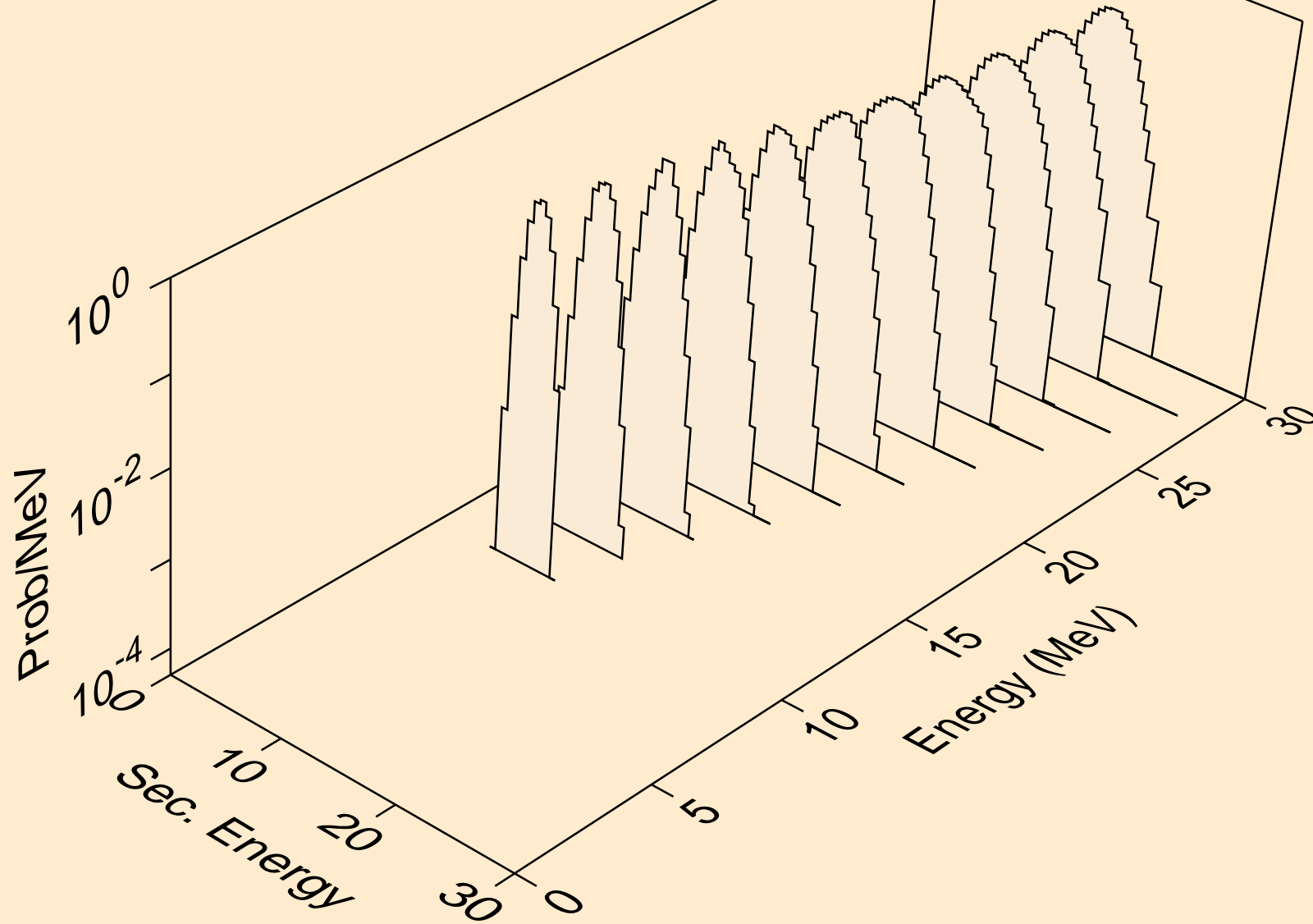

TA172 PHOTON ACER TENDL-2024 LIBRARY; T=0.K
alphas from (g,pa)

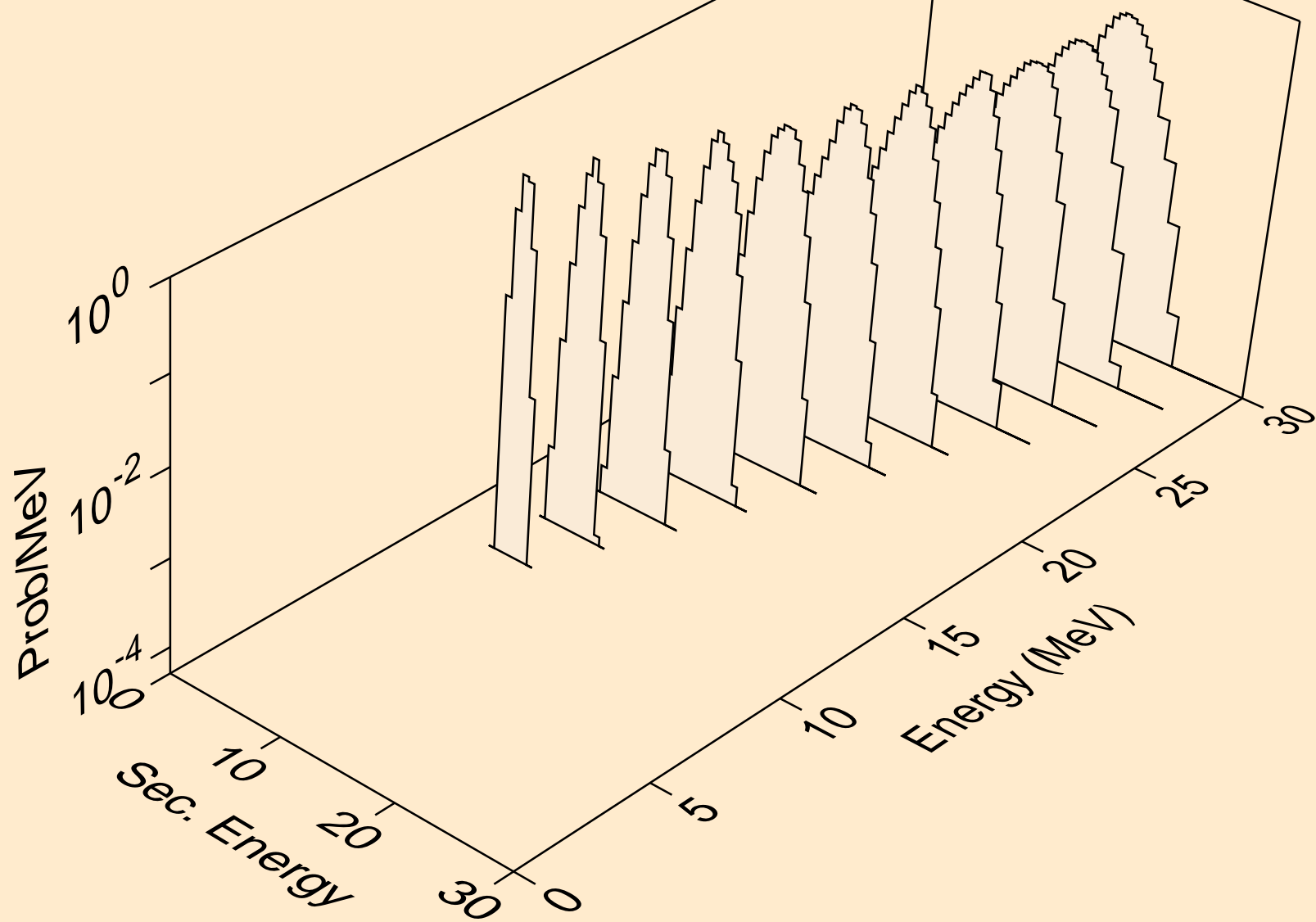

TA172 PHOTON ACER TENDL-2024 LIBRARY; T=0.K
alphas from (g,da)

