

# TH239 PHOTON ACER TENDL-2024 LIBRARY; T=0.K

## Principal cross sections

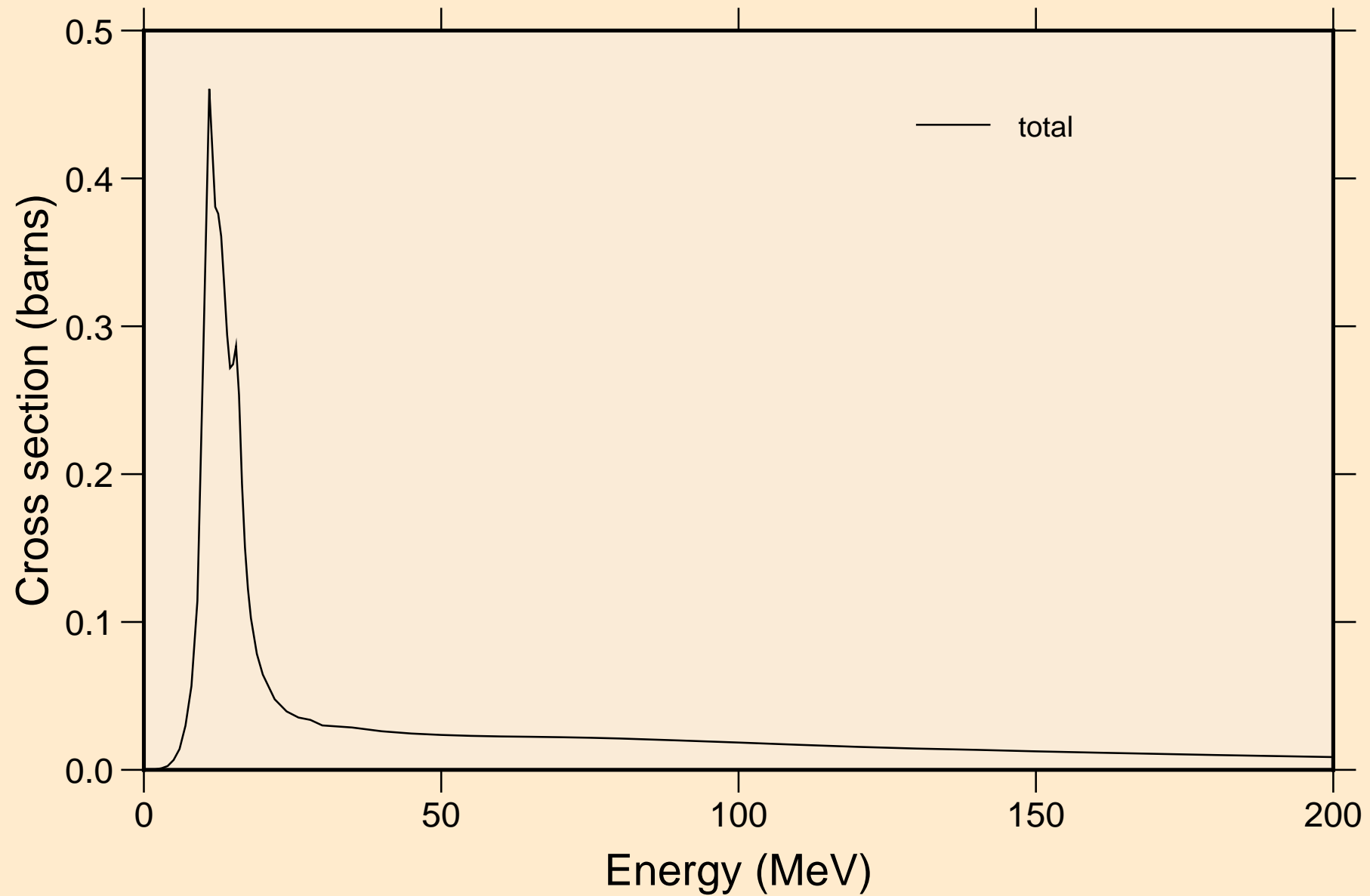

# TH239 PHOTON ACER TENDL-2024 LIBRARY; T=0.K

## Partial cross sections

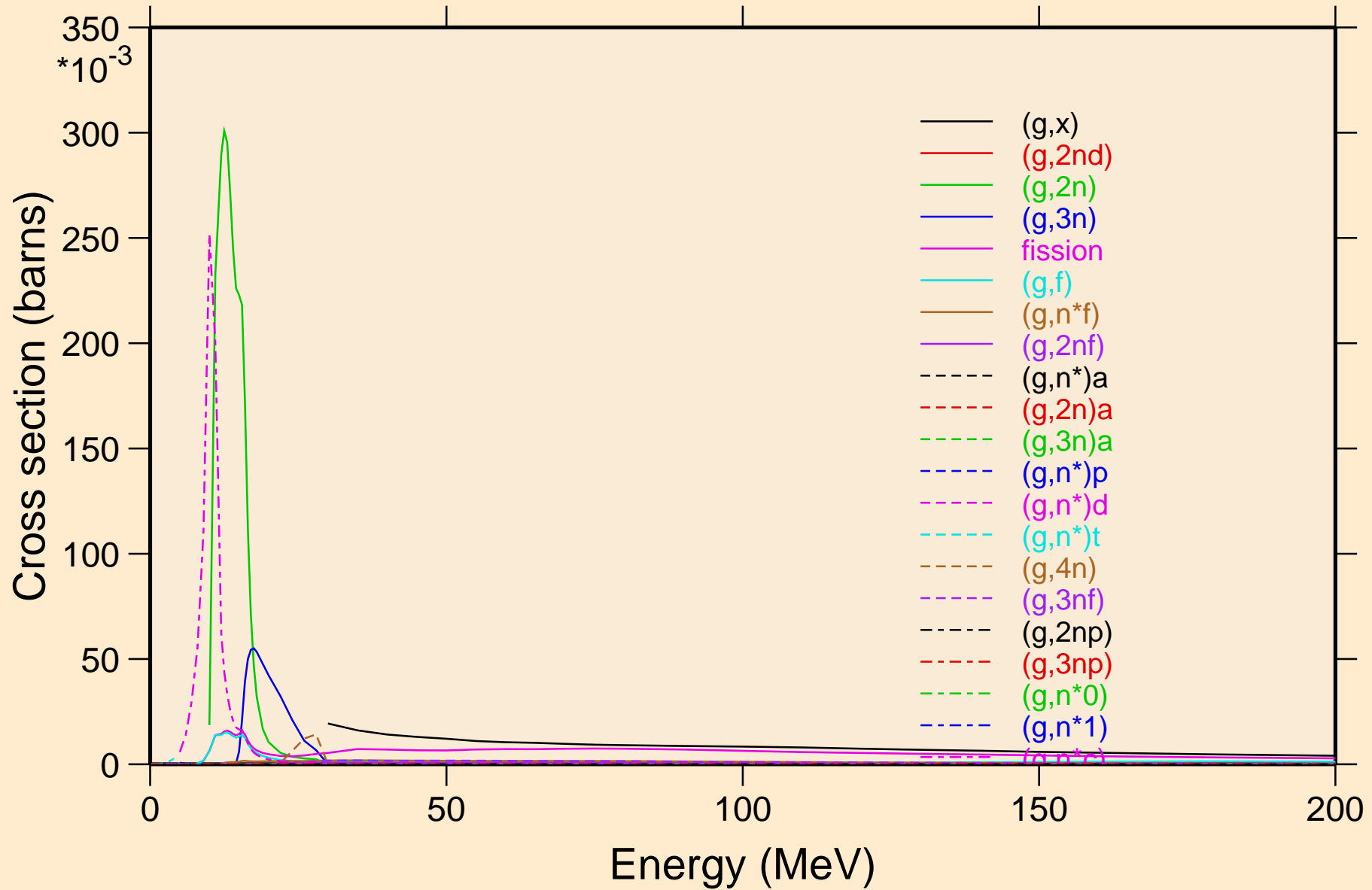

TH239 PHOTON ACER TENDL-2024 LIBRARY; T=0.K

Heating

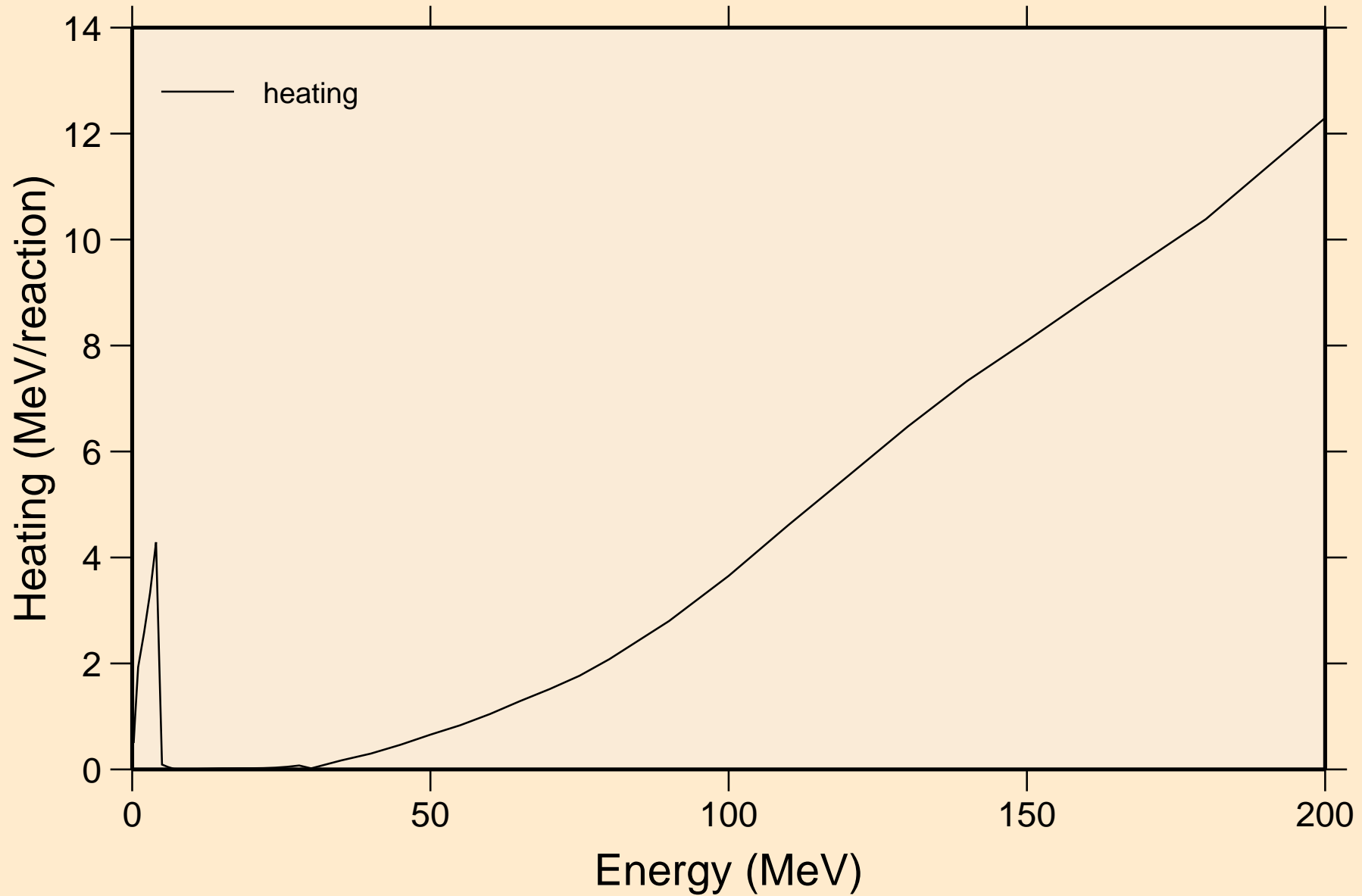

# TH239 PHOTON ACER TENDL-2024 LIBRARY; T=0.K

## Particle heating contributions

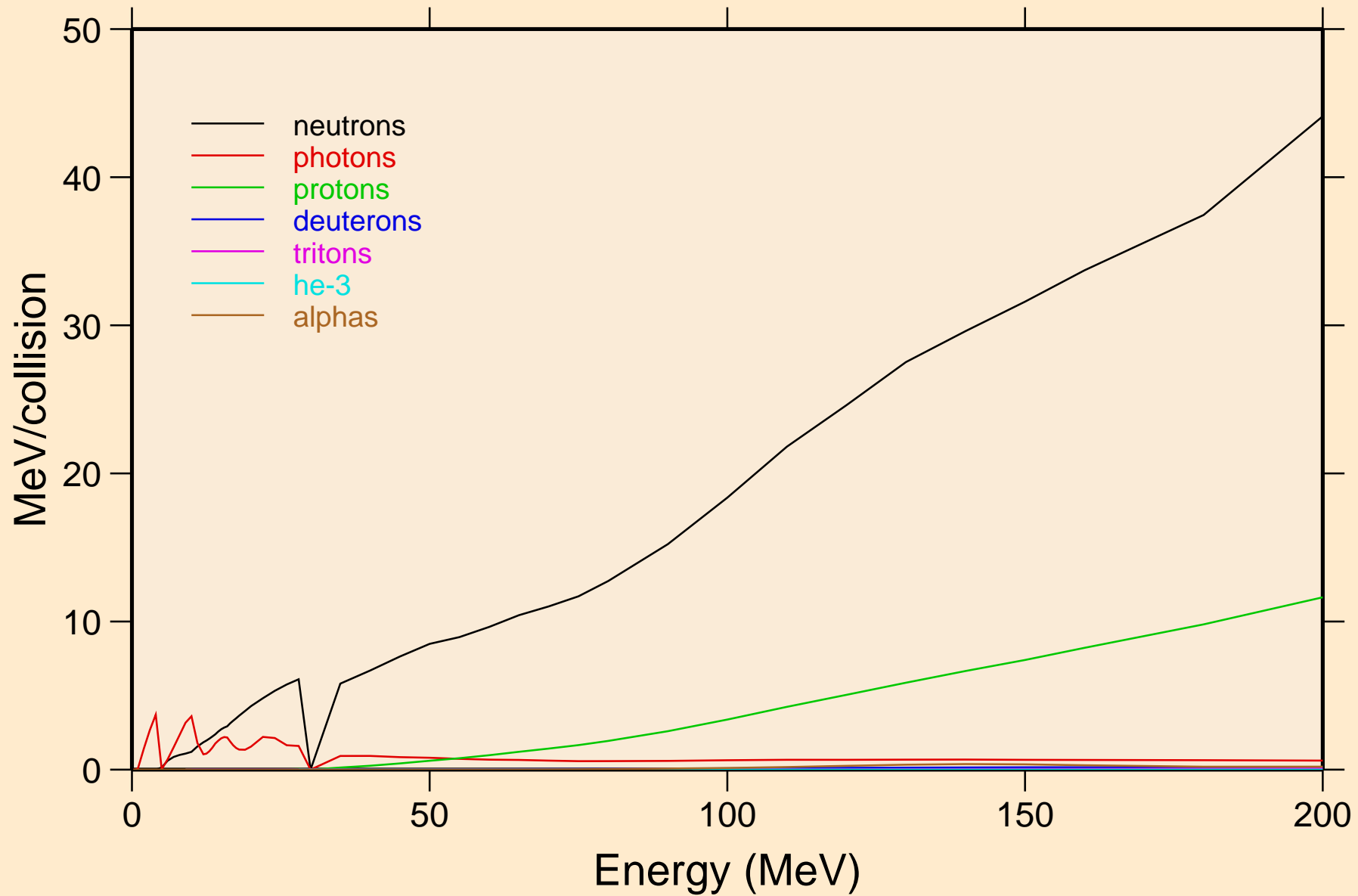

TH239 PHOTON ACER TENDL-2024 LIBRARY; T=0.K  
Particle production cross sections

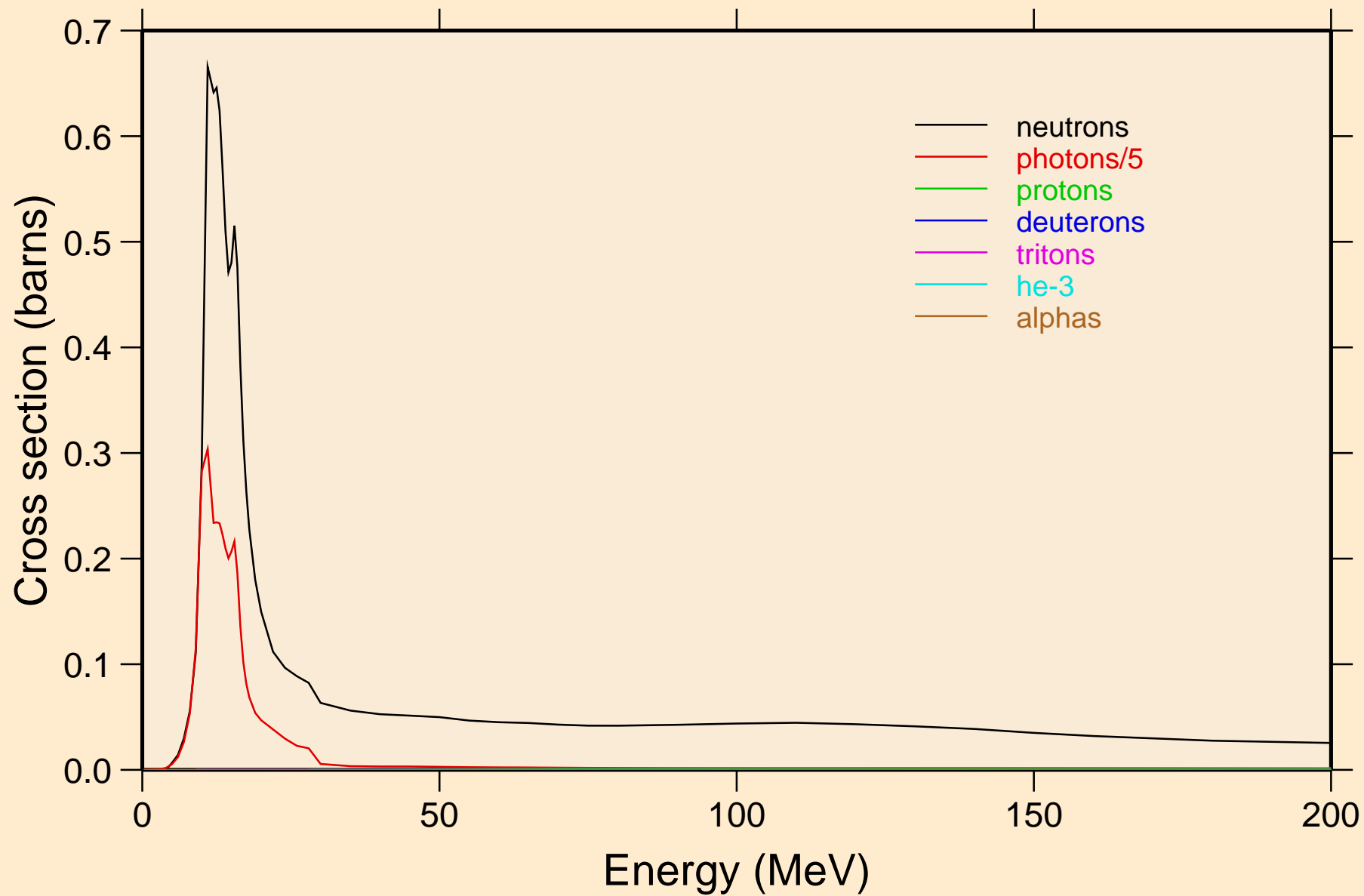

TH239 PHOTON ACER TENDL-2024 LIBRARY; T=0.K  
neutrons from (g,x)

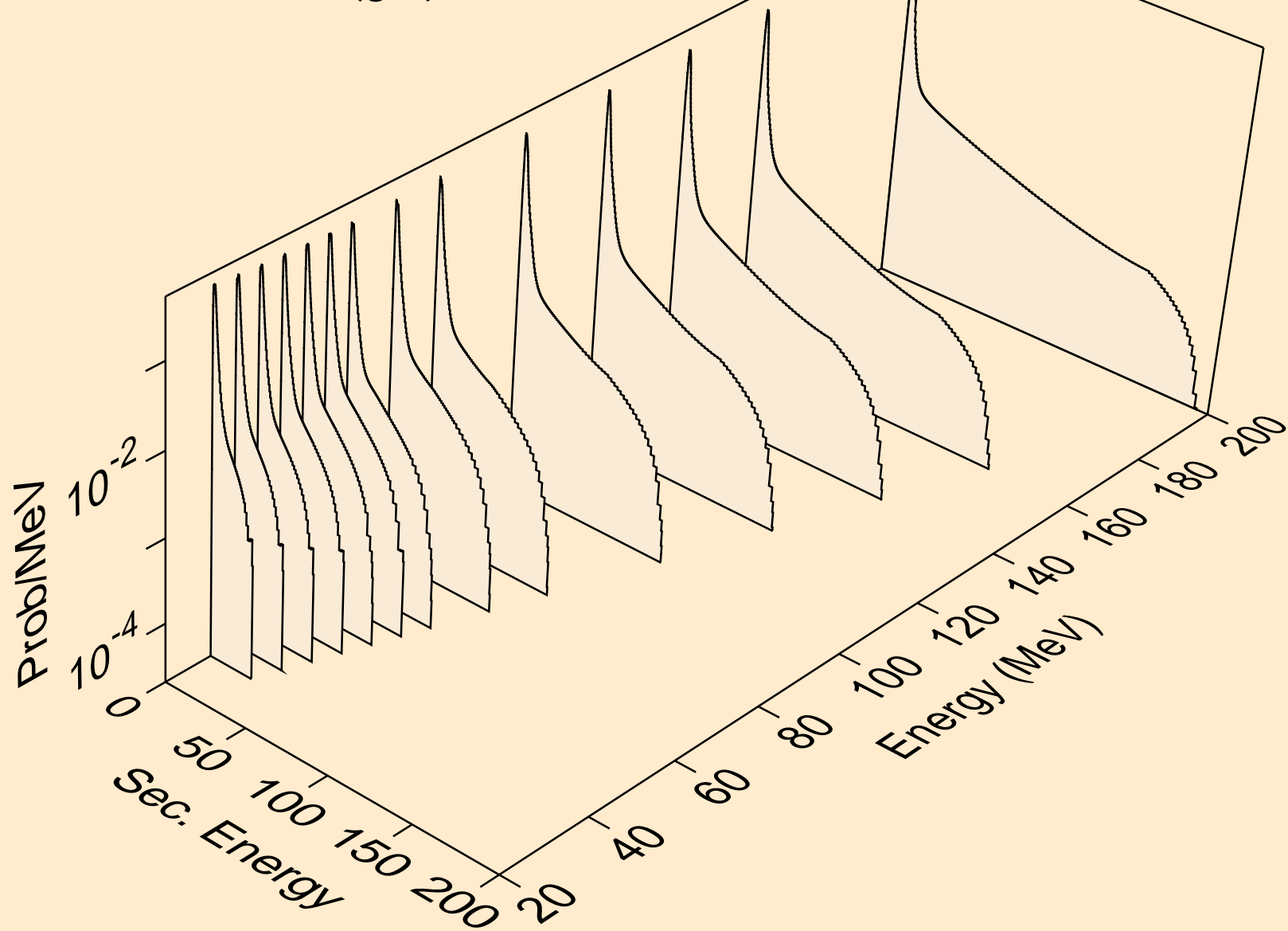

TH239 PHOTON ACER TENDL-2024 LIBRARY; T=0.K  
neutrons from (g,2nd)

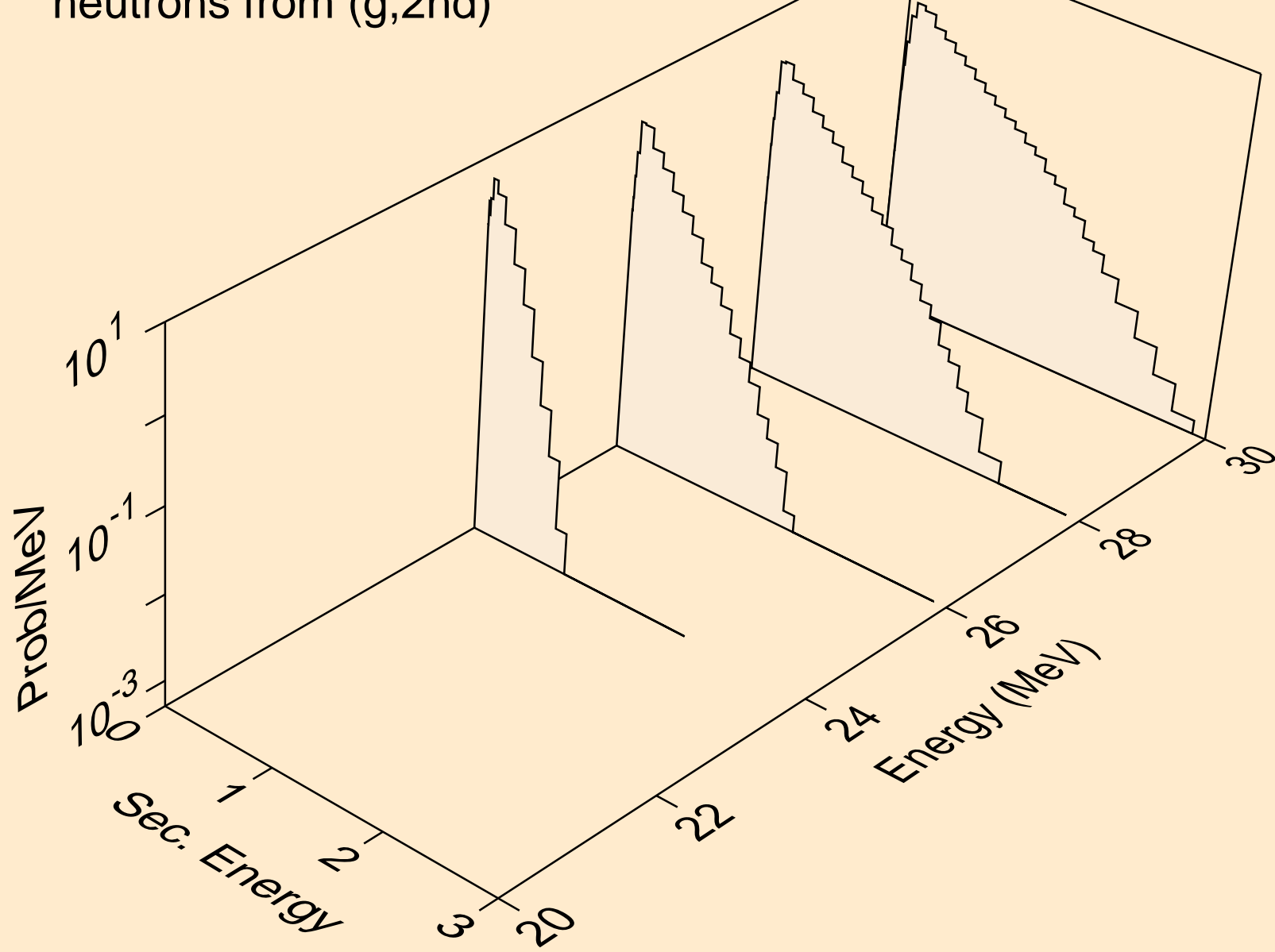

TH239 PHOTON ACER TENDL-2024 LIBRARY; T=0.K  
neutrons from (g,2n)

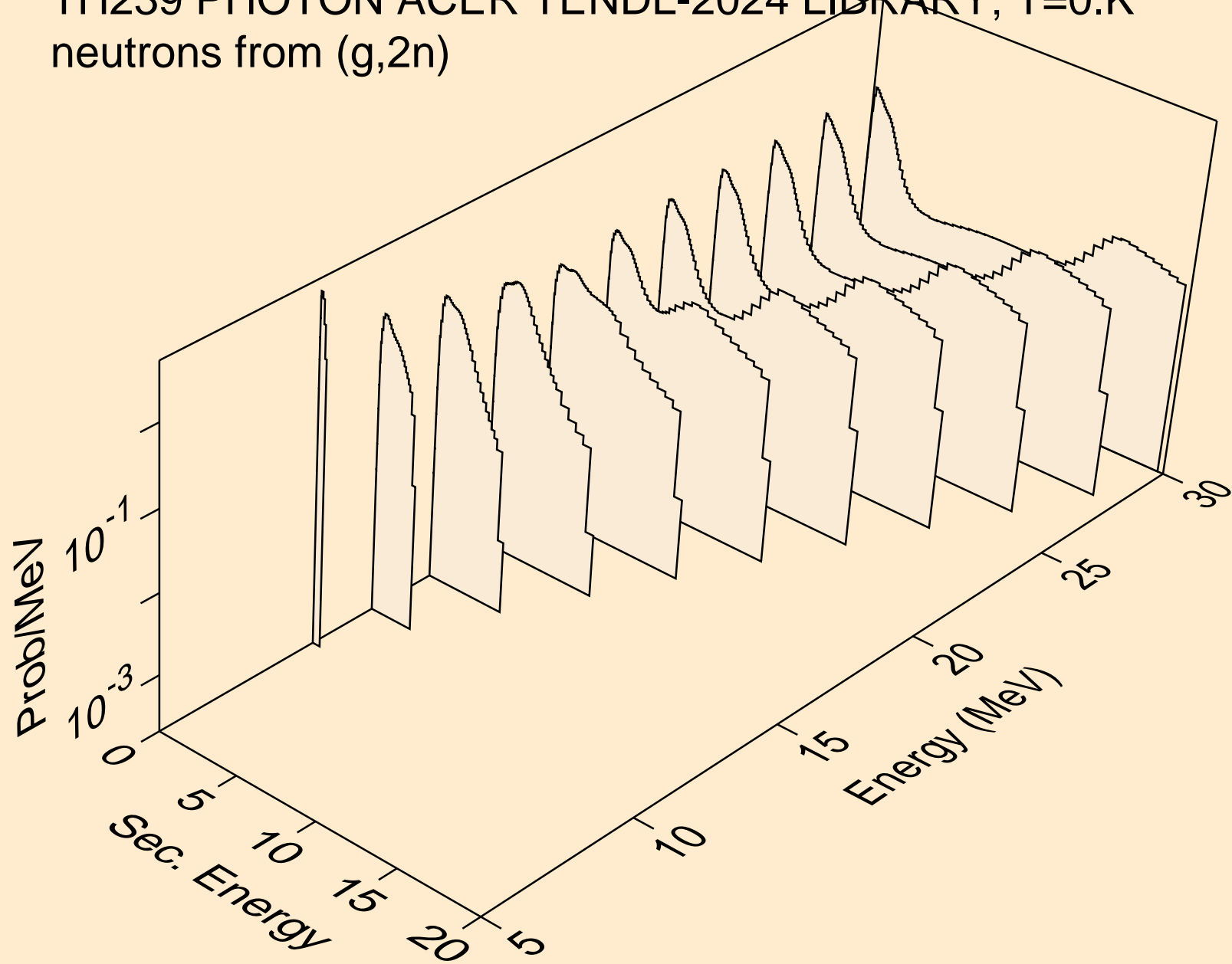

TH239 PHOTON ACER TENDL-2024 LIBRARY; T=0.K  
neutrons from (g,3n)

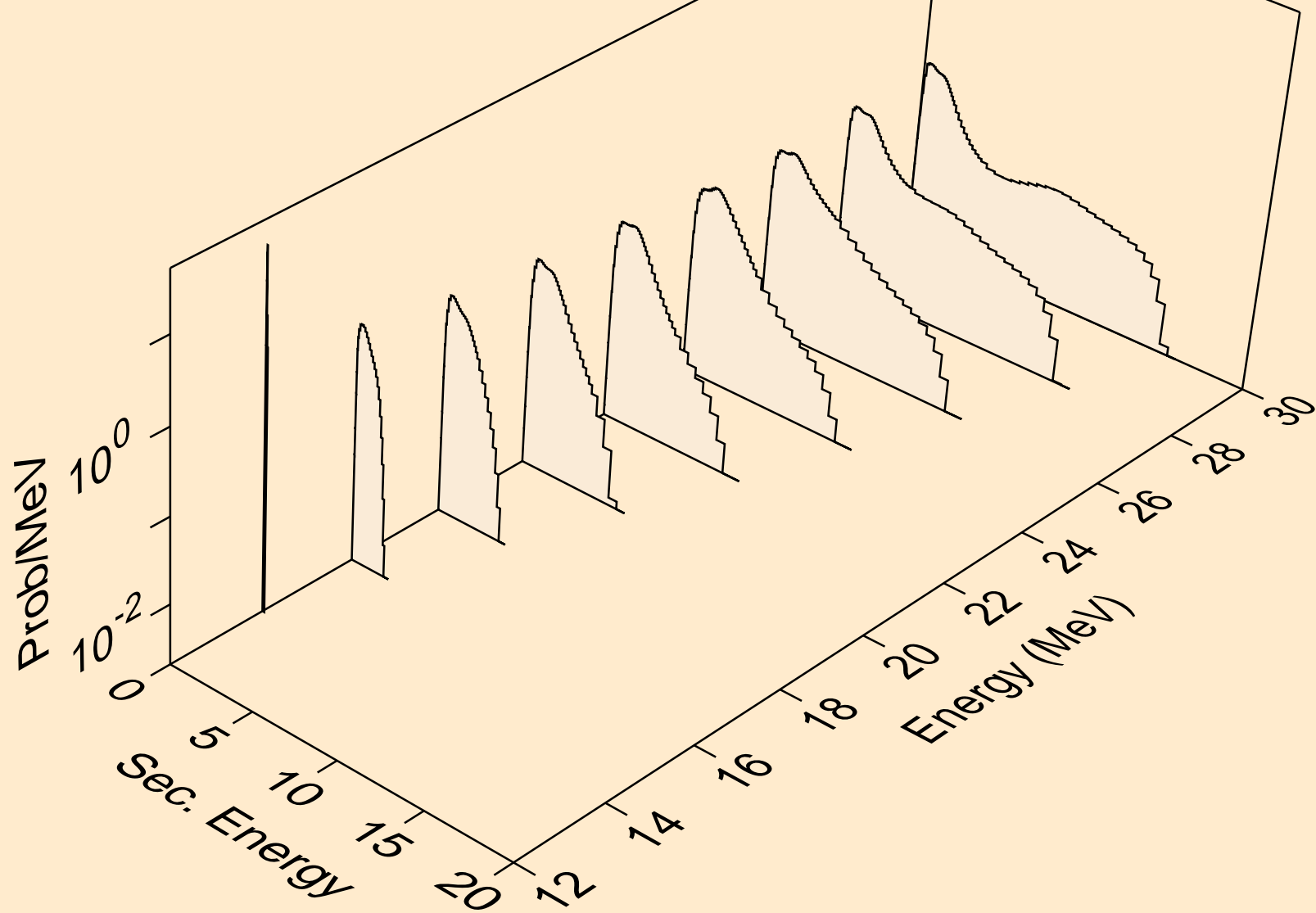

TH239 PHOTON ACER TENDL-2024 LIBRARY; T=0.K  
neutrons from (g,n\*)a

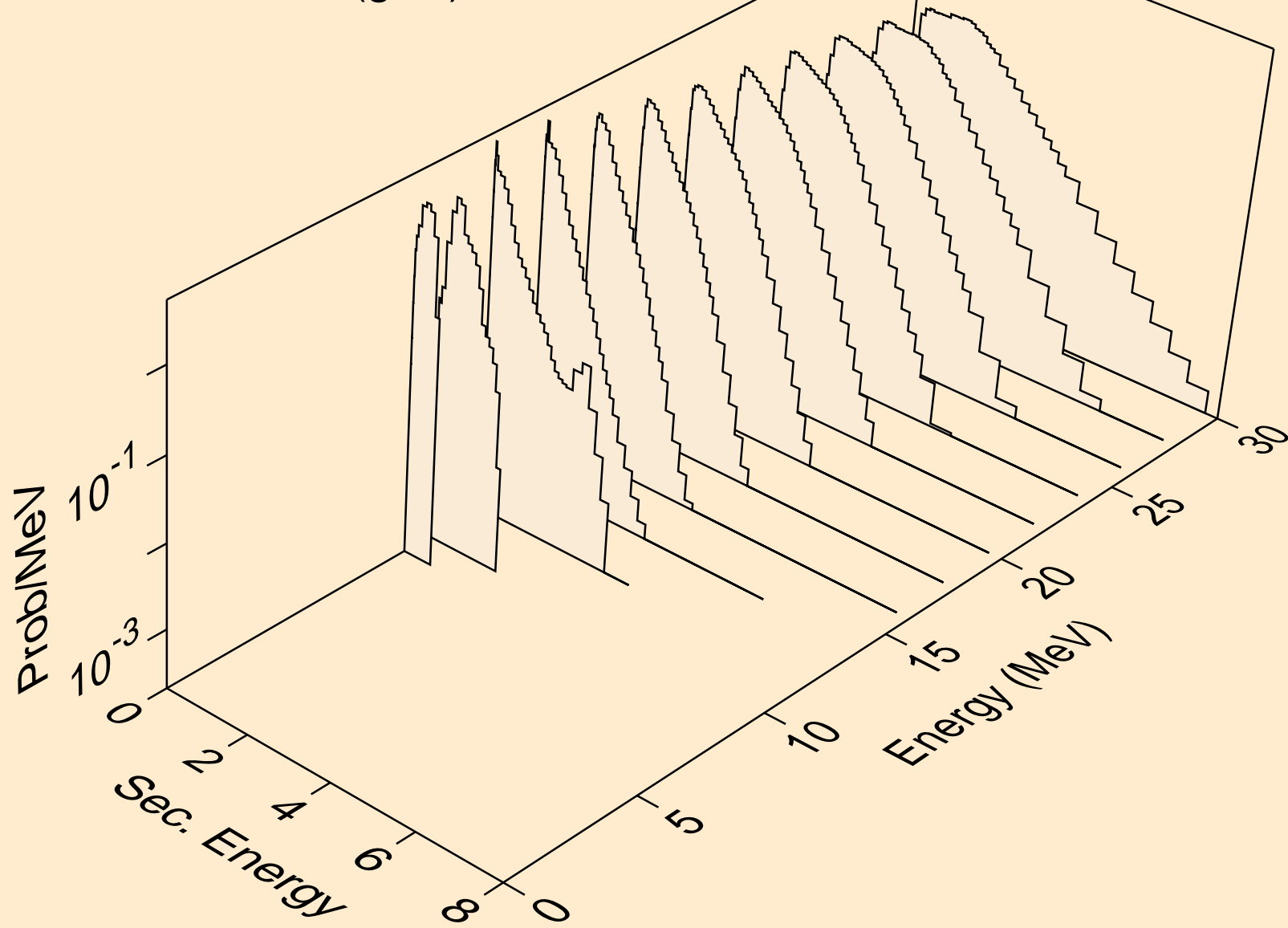

TH239 PHOTON ACER TENDL-2024 LIBRARY; T=0.K  
neutrons from (g,2n)a

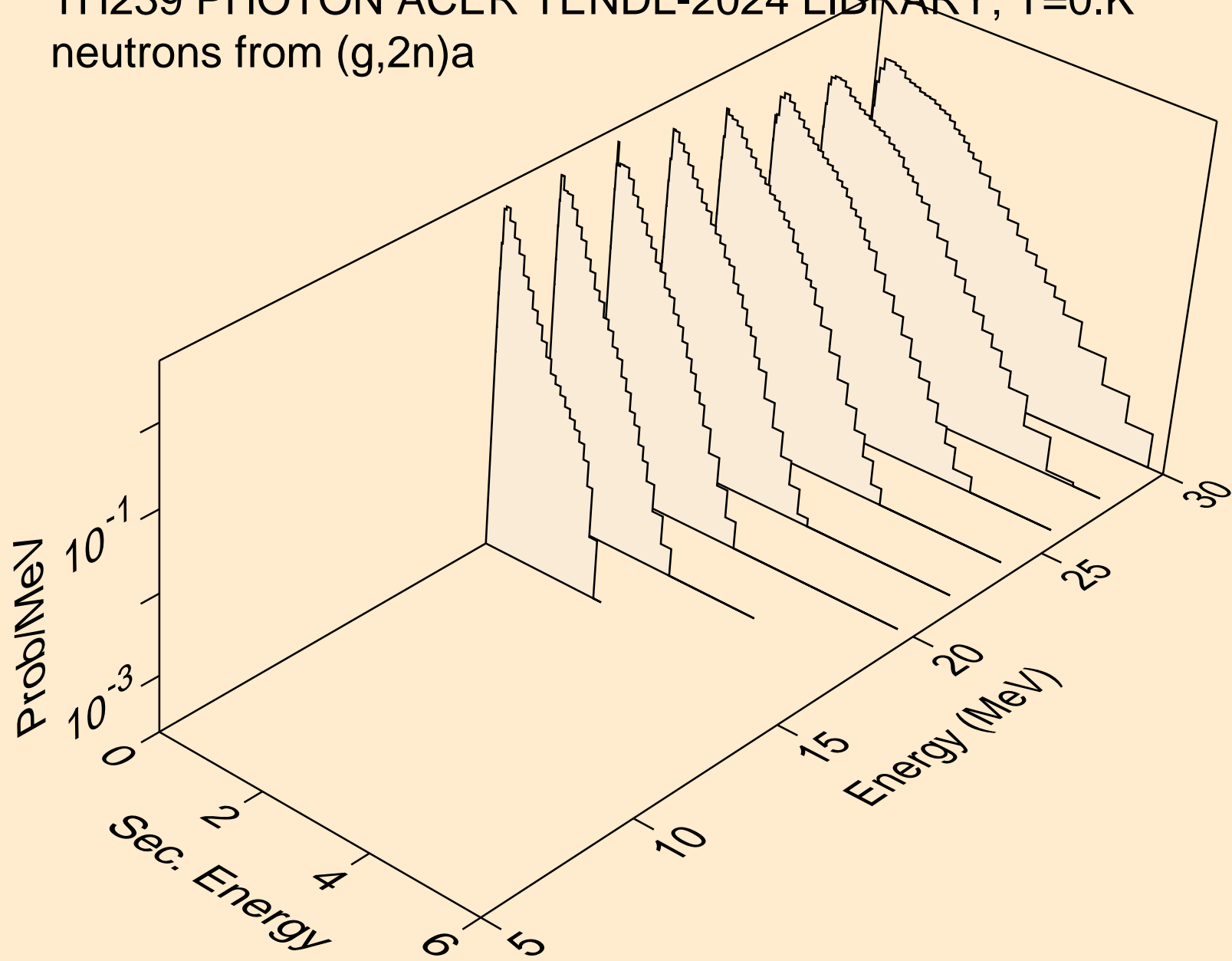

TH239 PHOTON ACER TENDL-2024 LIBRARY; T=0.K  
neutrons from (g,3n)a

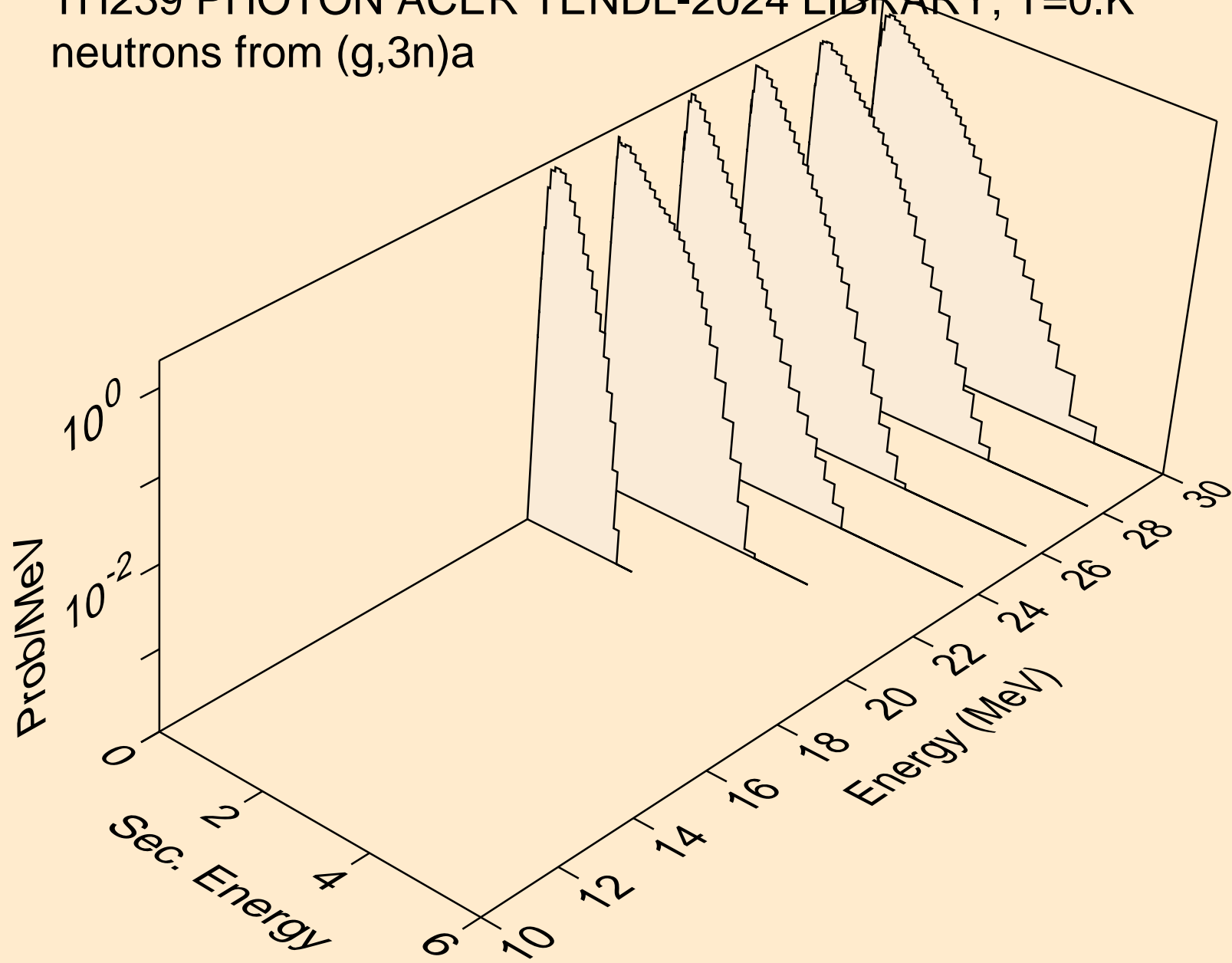

TH239 PHOTON ACER TENDL-2024 LIBRARY; T=0.K  
neutrons from (g,n\*)p

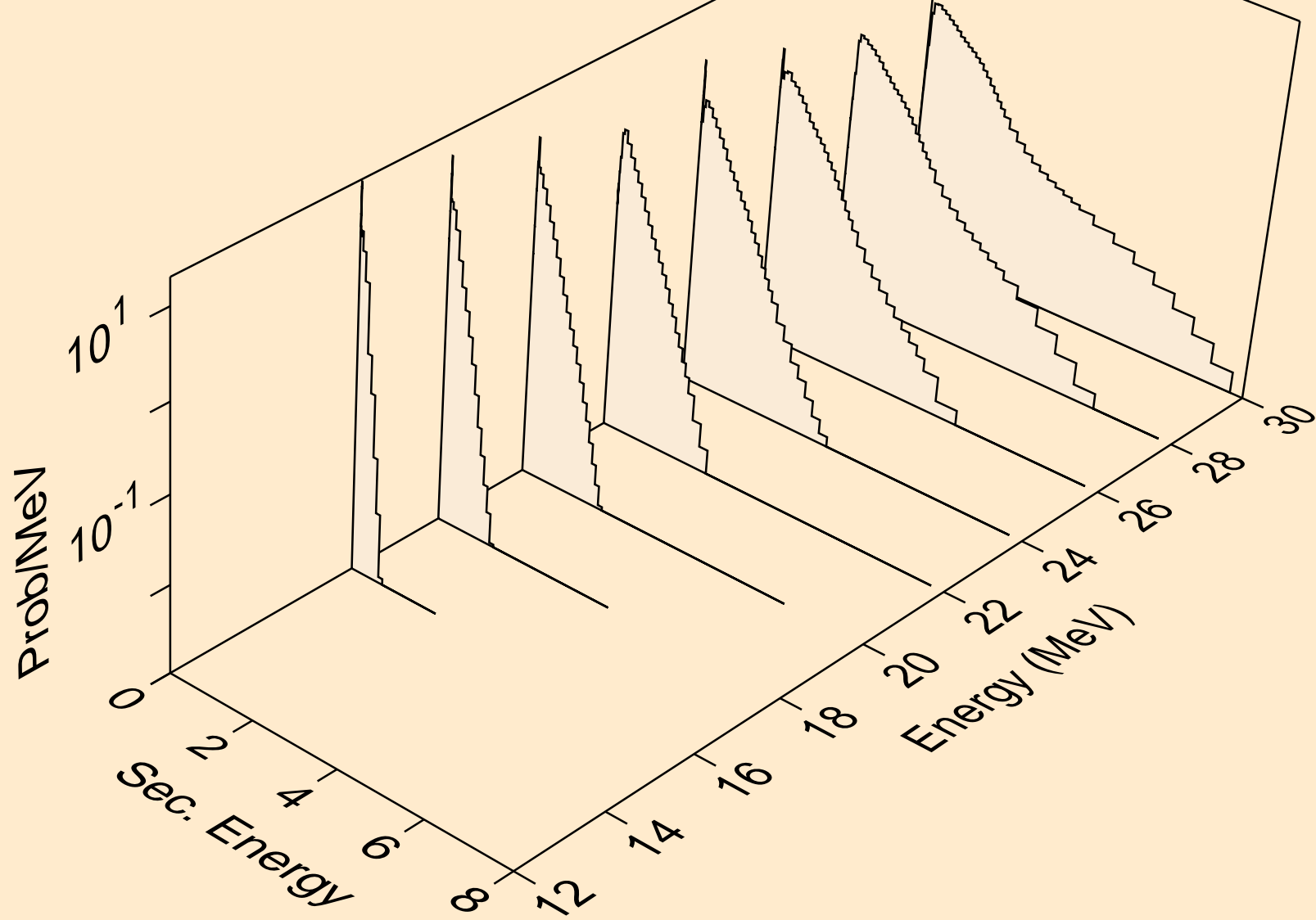

TH239 PHOTON ACER TENDL-2024 LIBRARY; T=0.K  
neutrons from (g,n\*)d

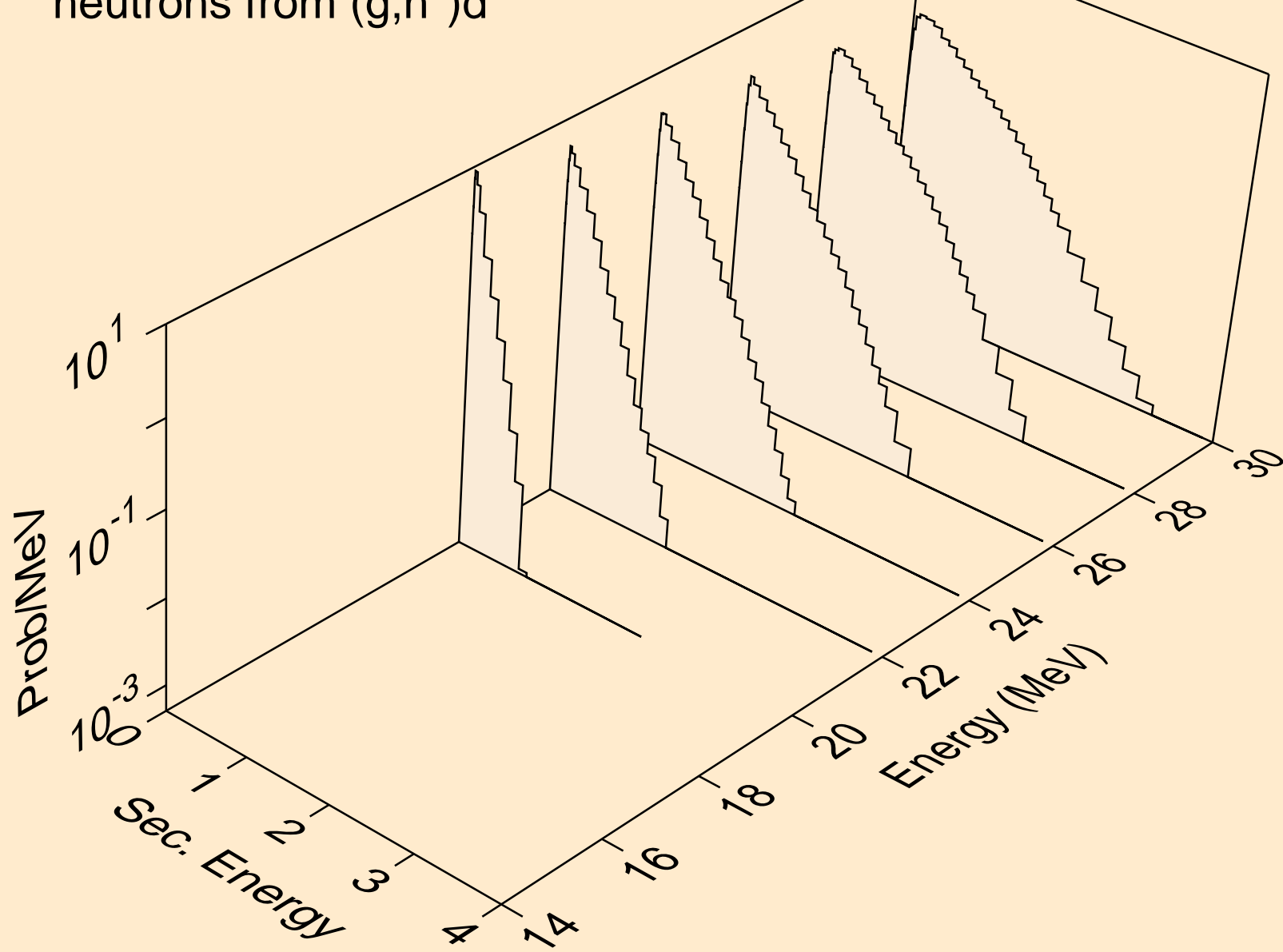

TH239 PHOTON ACER TENDL-2024 LIBRARY; T=0.K  
neutrons from (g,n\*)t

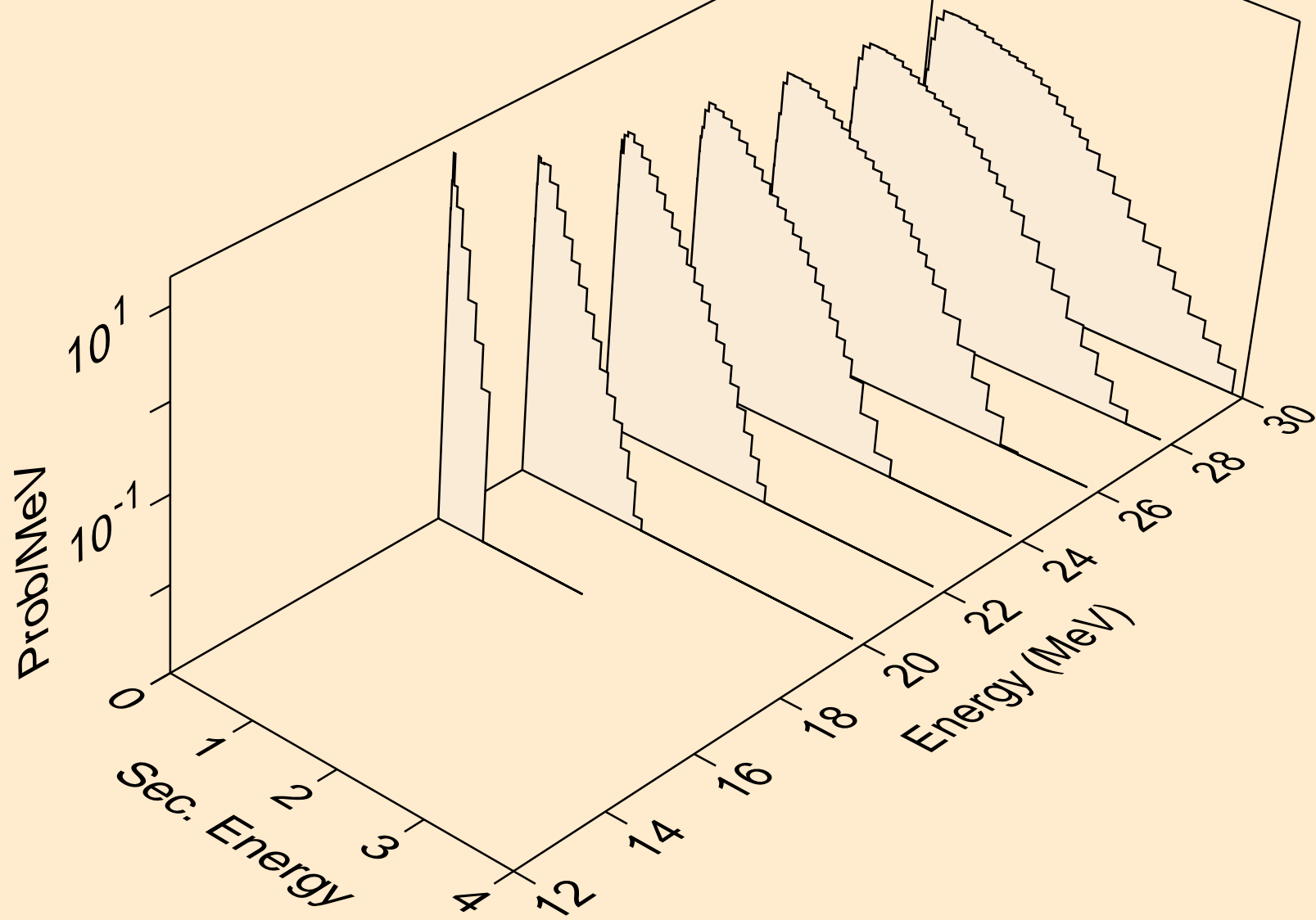

TH239 PHOTON ACER TENDL-2024 LIBRARY; T=0.K  
neutrons from (g,4n)

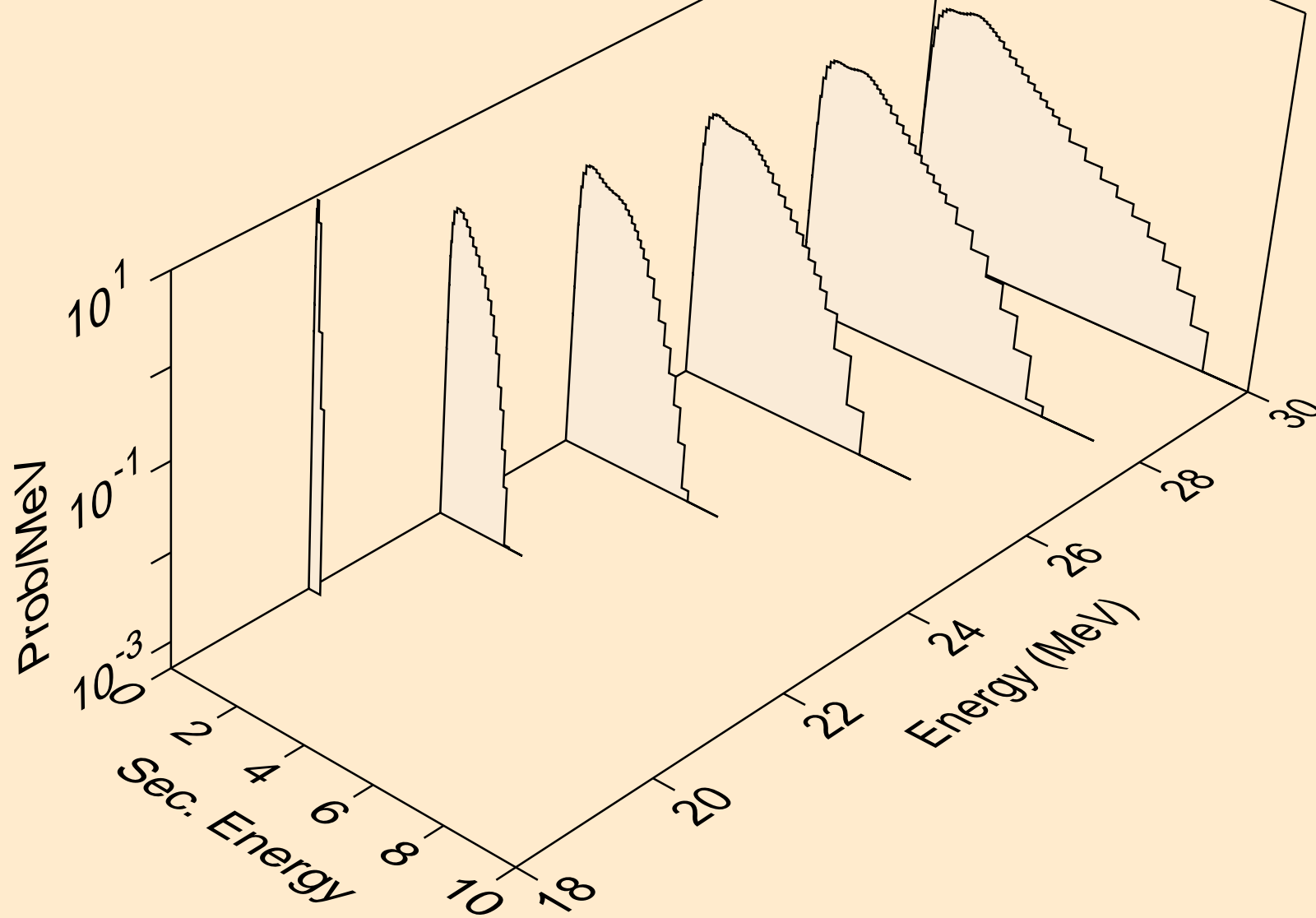

TH239 PHOTON ACER TENDL-2024 LIBRARY; T=0.K  
neutrons from (g,2np)

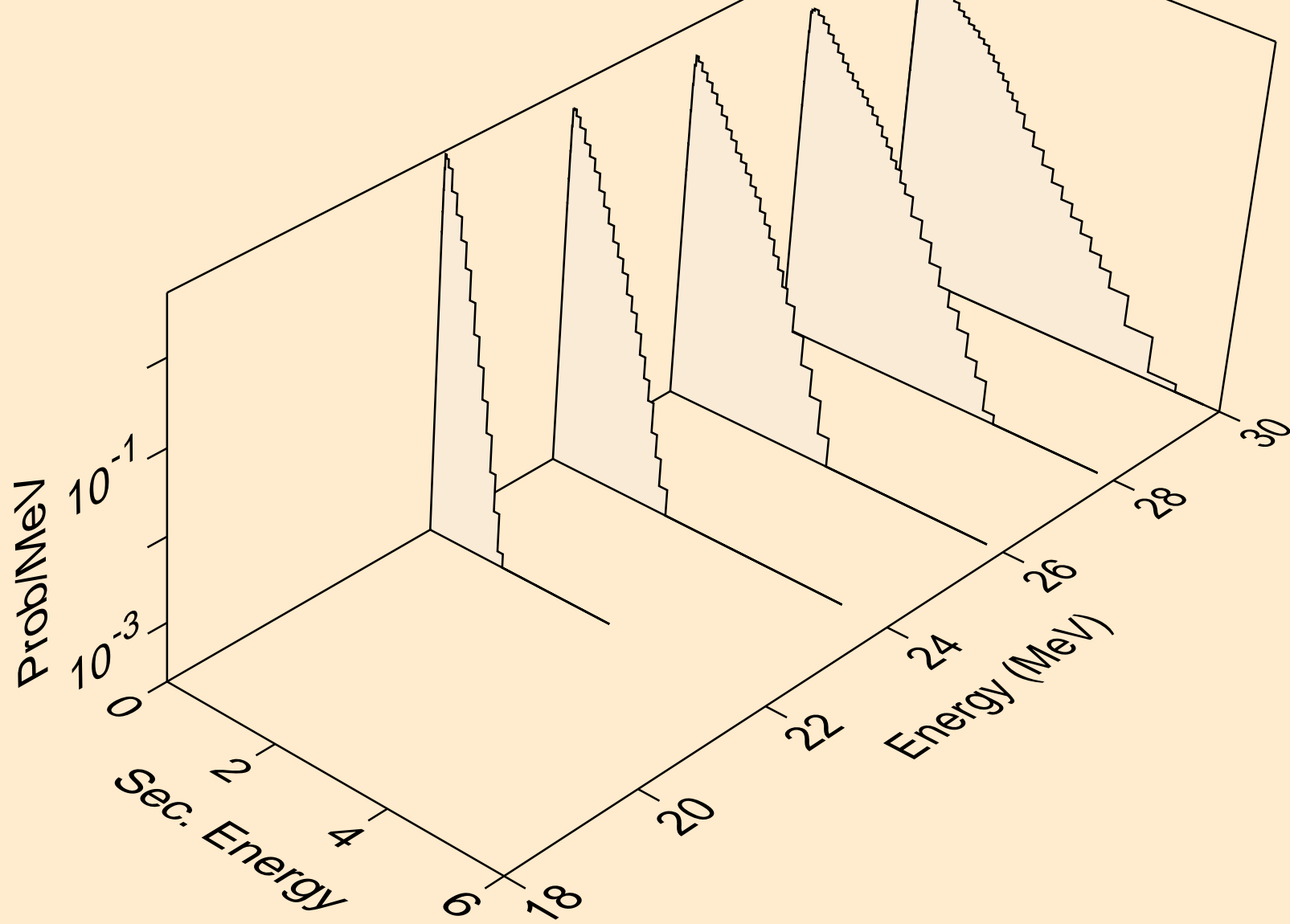

TH239 PHOTON ACER TENDL-2024 LIBRARY; T=0.K  
neutrons from (g,3np)

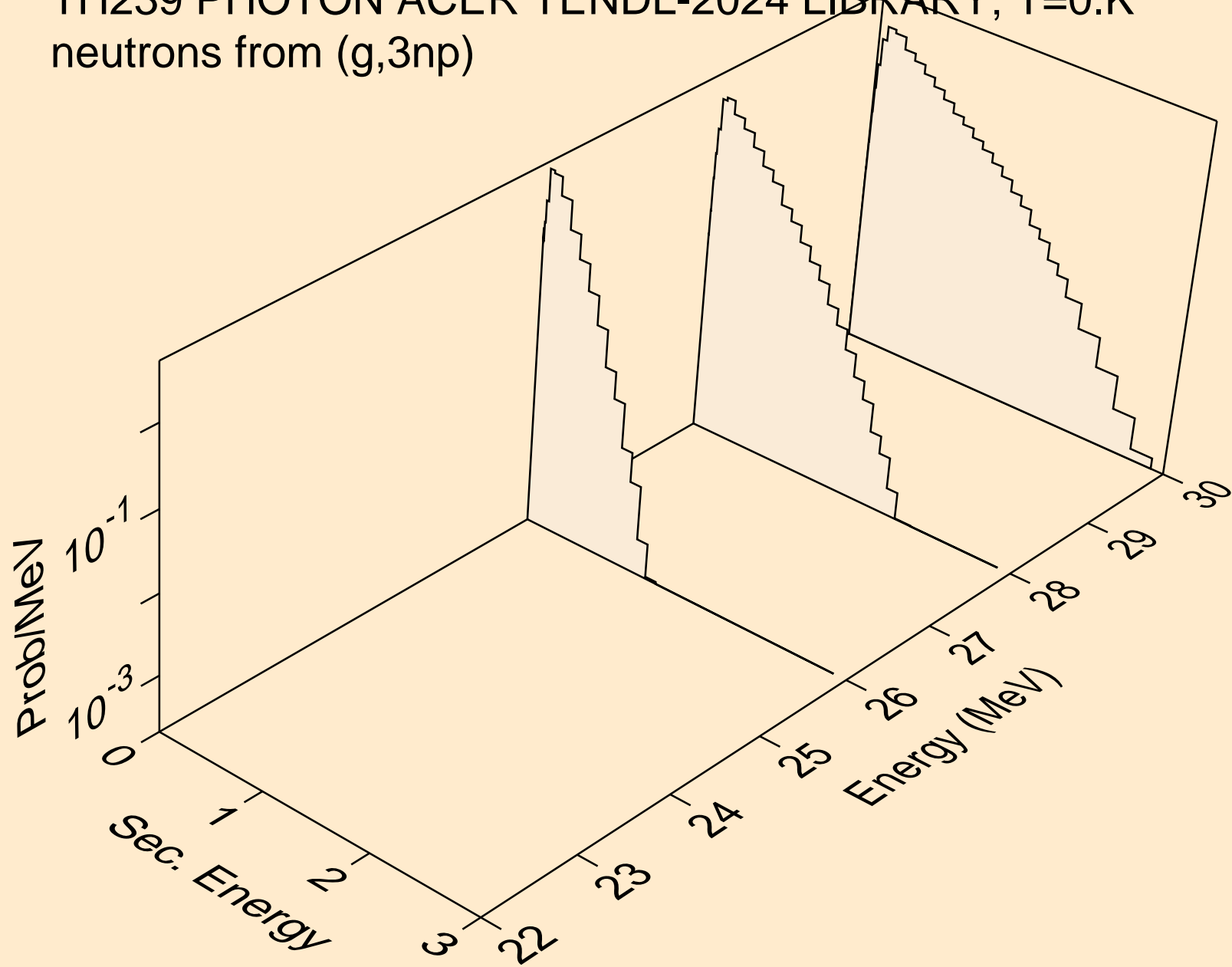

TH239 PHOTON ACER TENDL-2024 LIBRARY; T=0.K  
angular distribution for (g,n\*0) neutron

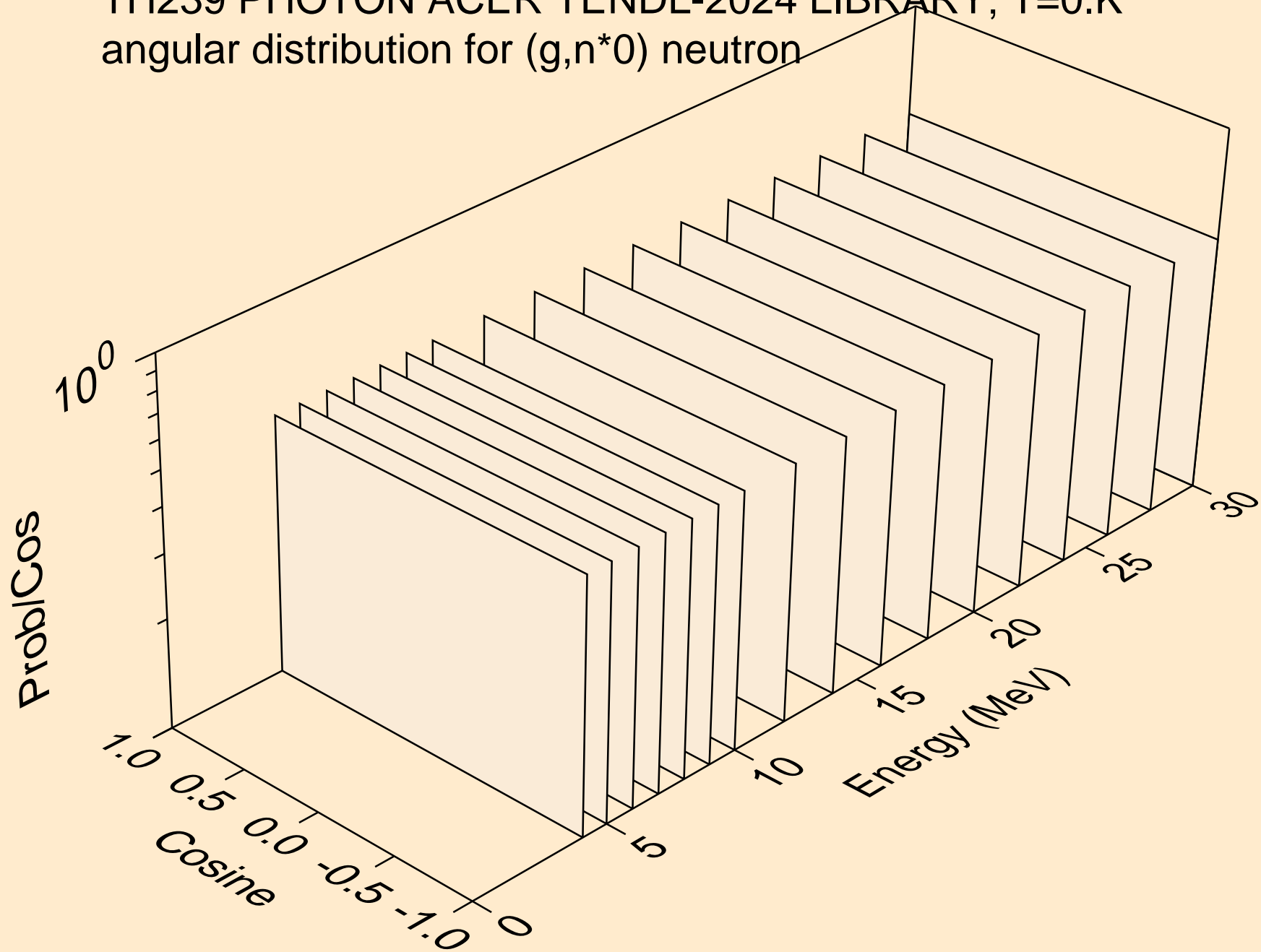

TH239 PHOTON ACER TENDL-2024 LIBRARY; T=0.K  
angular distribution for (g,n\*1) neutron

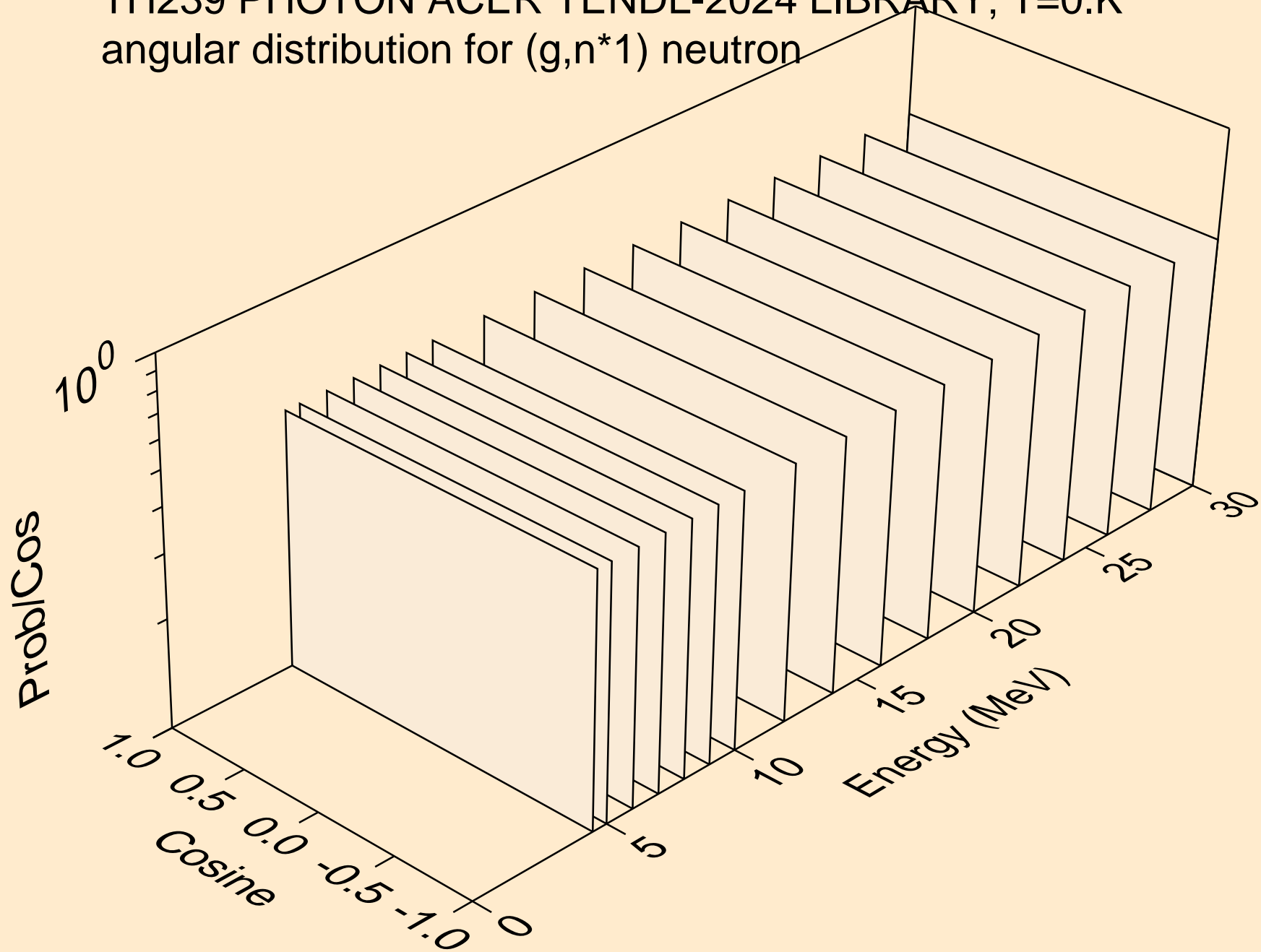

TH239 PHOTON ACER TENDL-2024 LIBRARY; T=0.K  
neutrons from (g,n\*c)

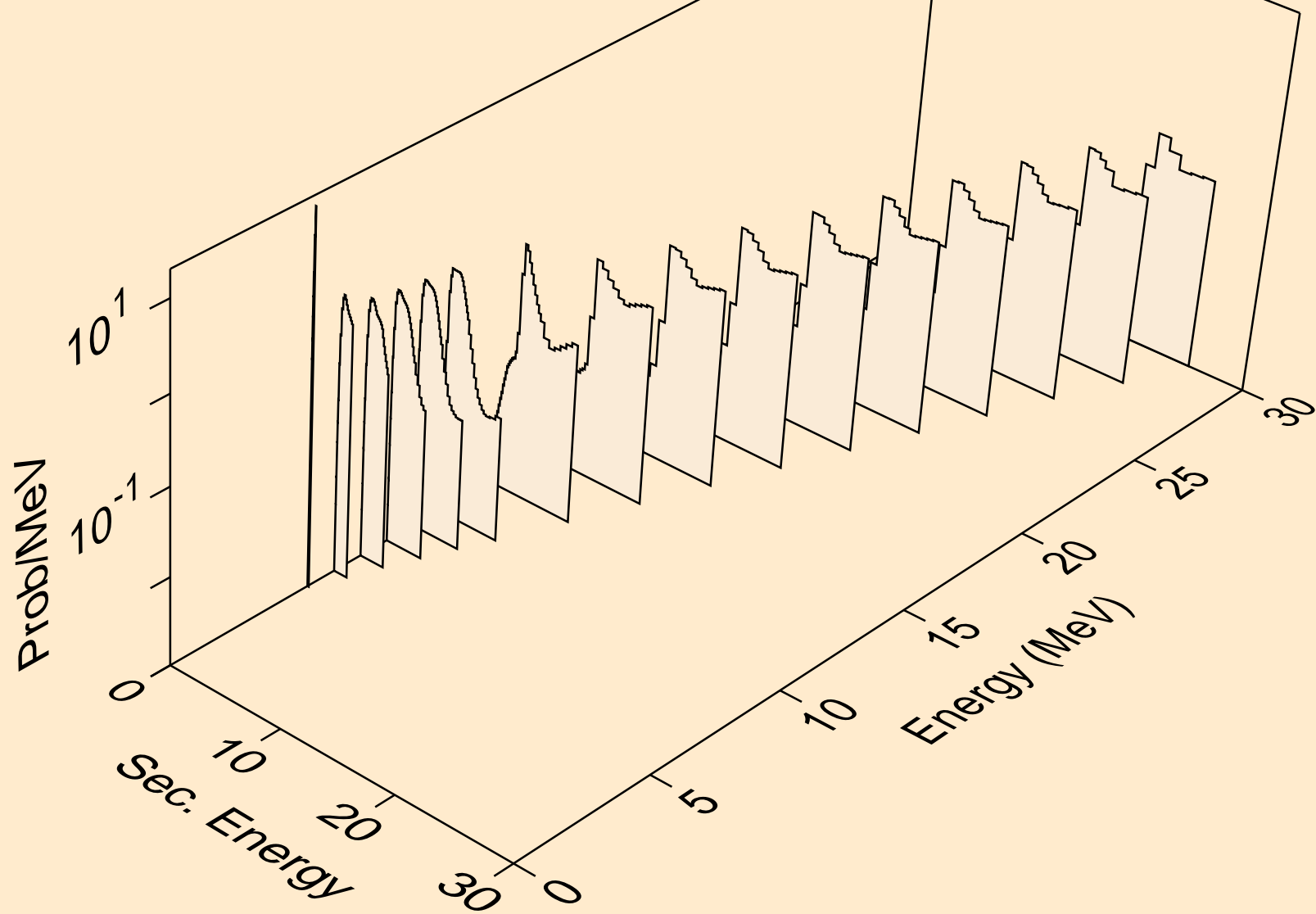

TH239 PHOTON ACER TENDL-2024 LIBRARY; T=0.K  
photons from (g,x)

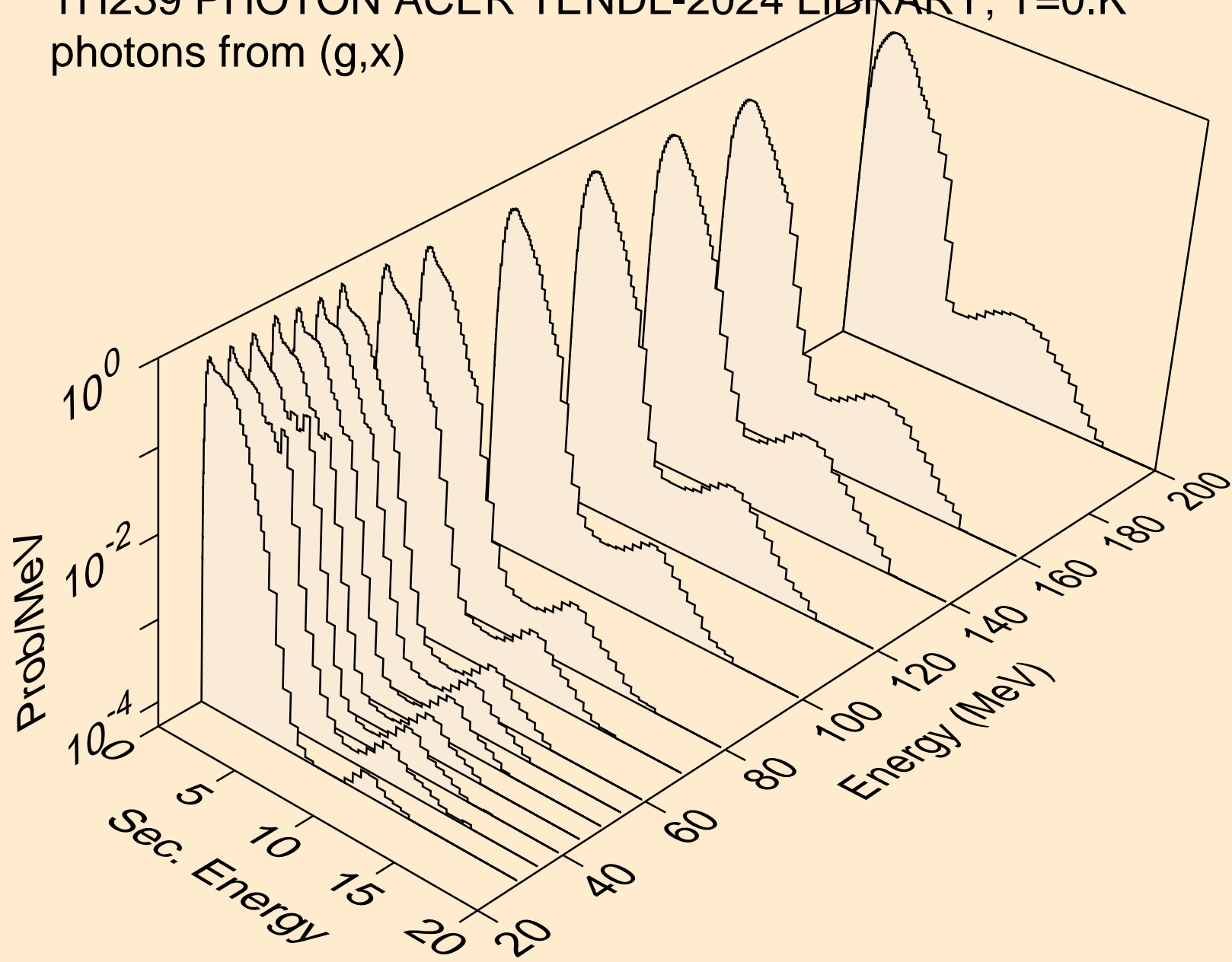

TH239 PHOTON ACER TENDL-2024 LIBRARY; T=0.K  
photons from (g,2nd)

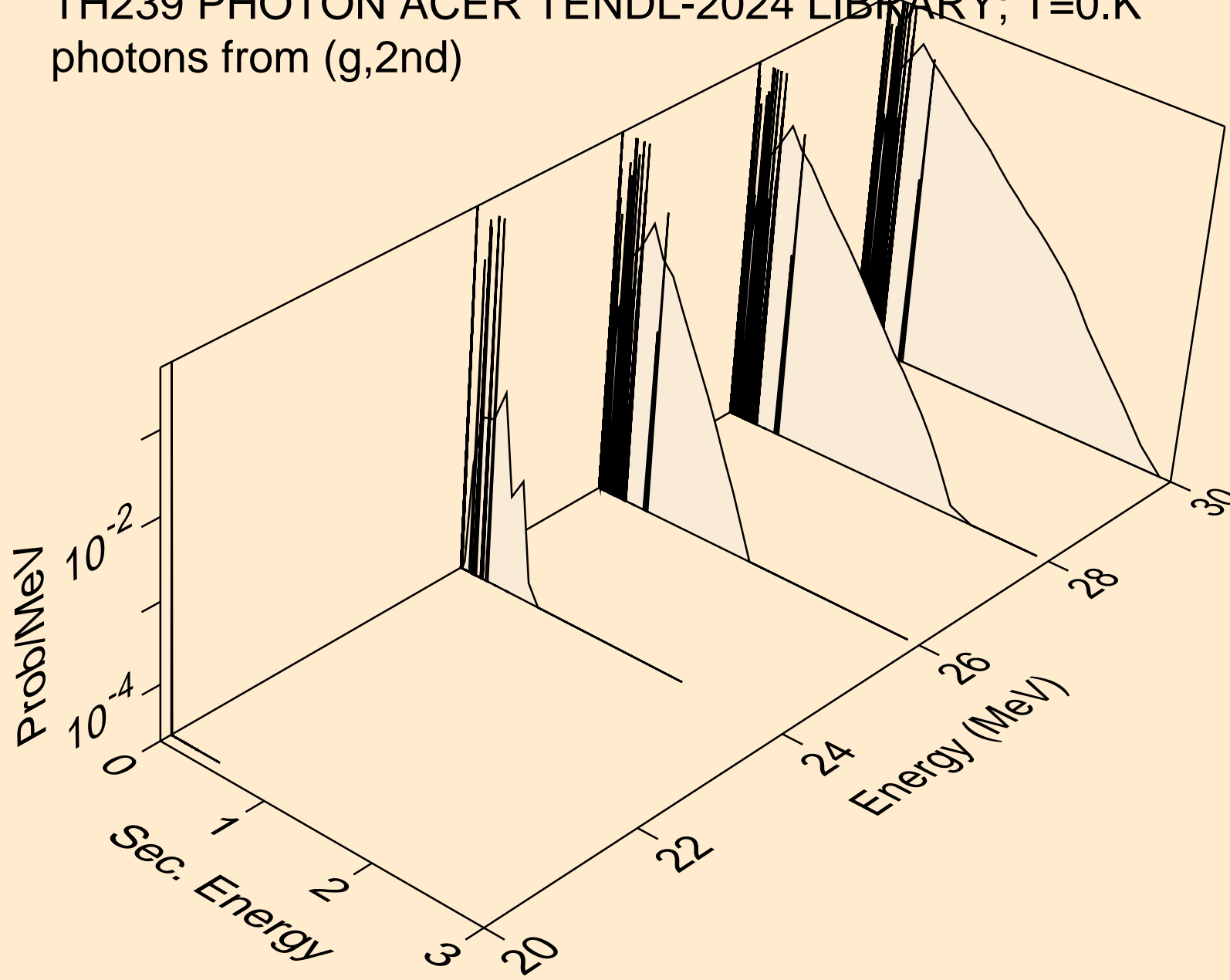

TH239 PHOTON ACER TENDL-2024 LIBRARY; T=0.K  
photons from (g,2n)

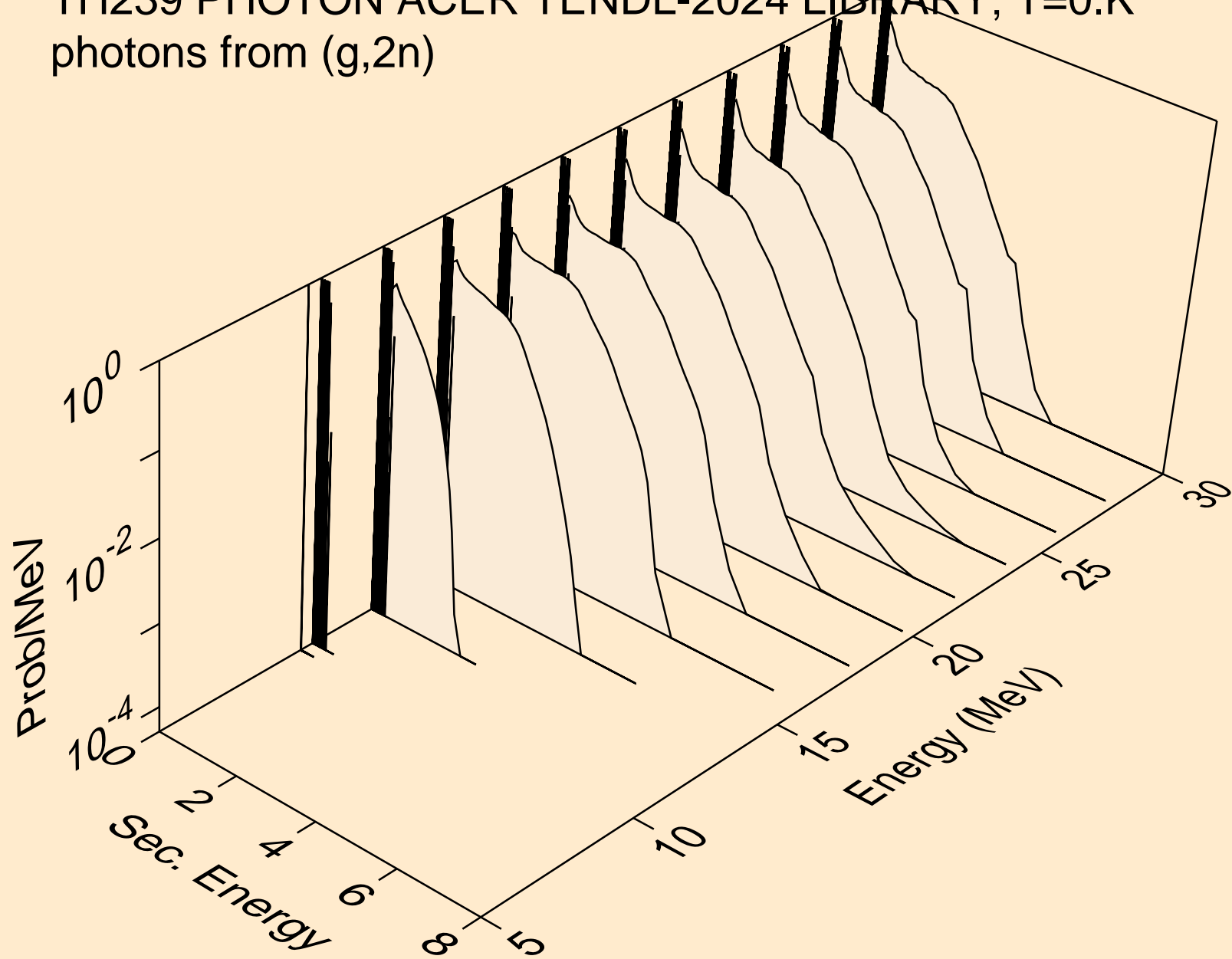

TH239 PHOTON ACER TENDL-2024 LIBRARY; T=0.K  
photons from (g,3n)

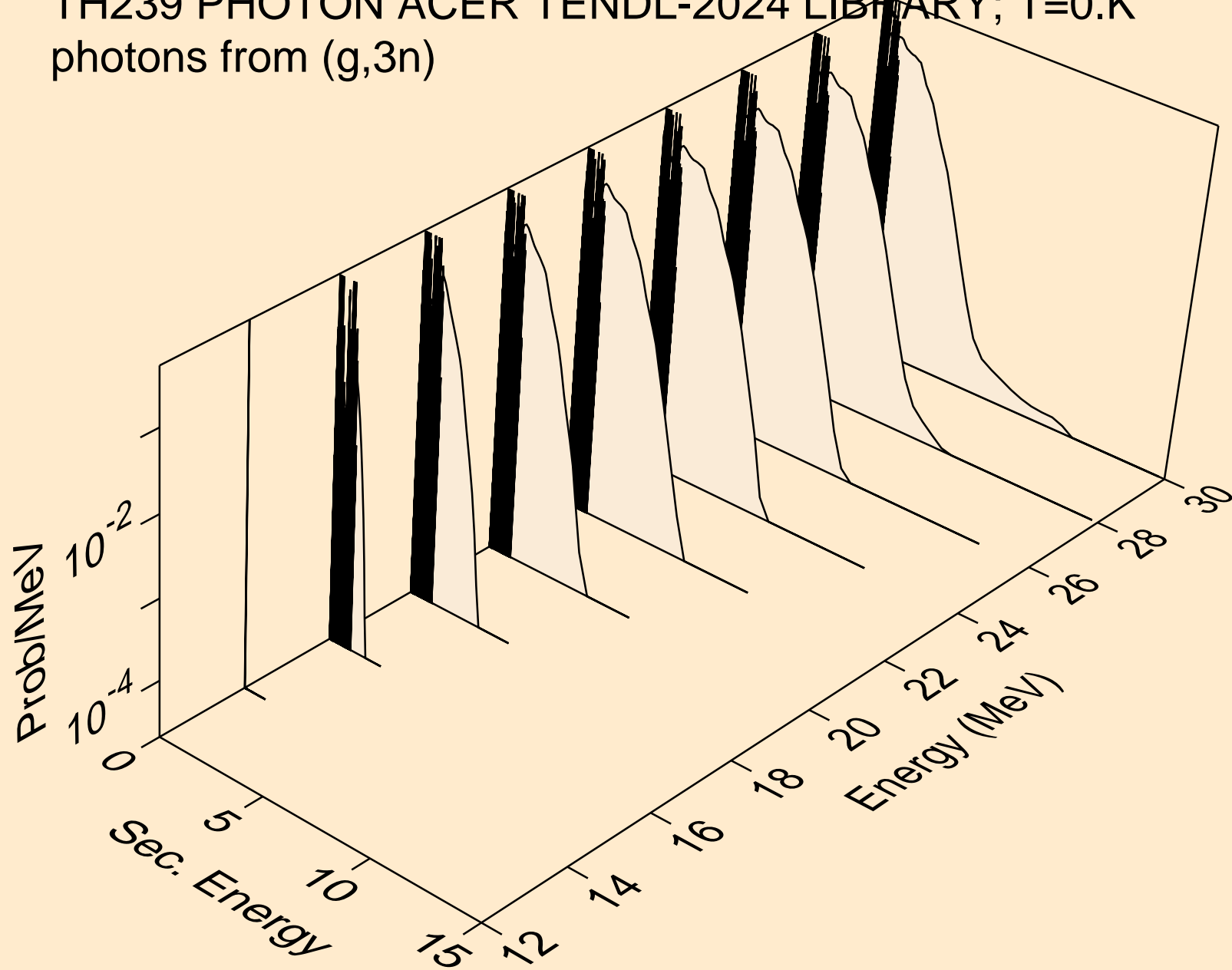

TH239 PHOTON ACER TENDL-2024 LIBRARY; T=0.K  
photons from (g,n\*)a

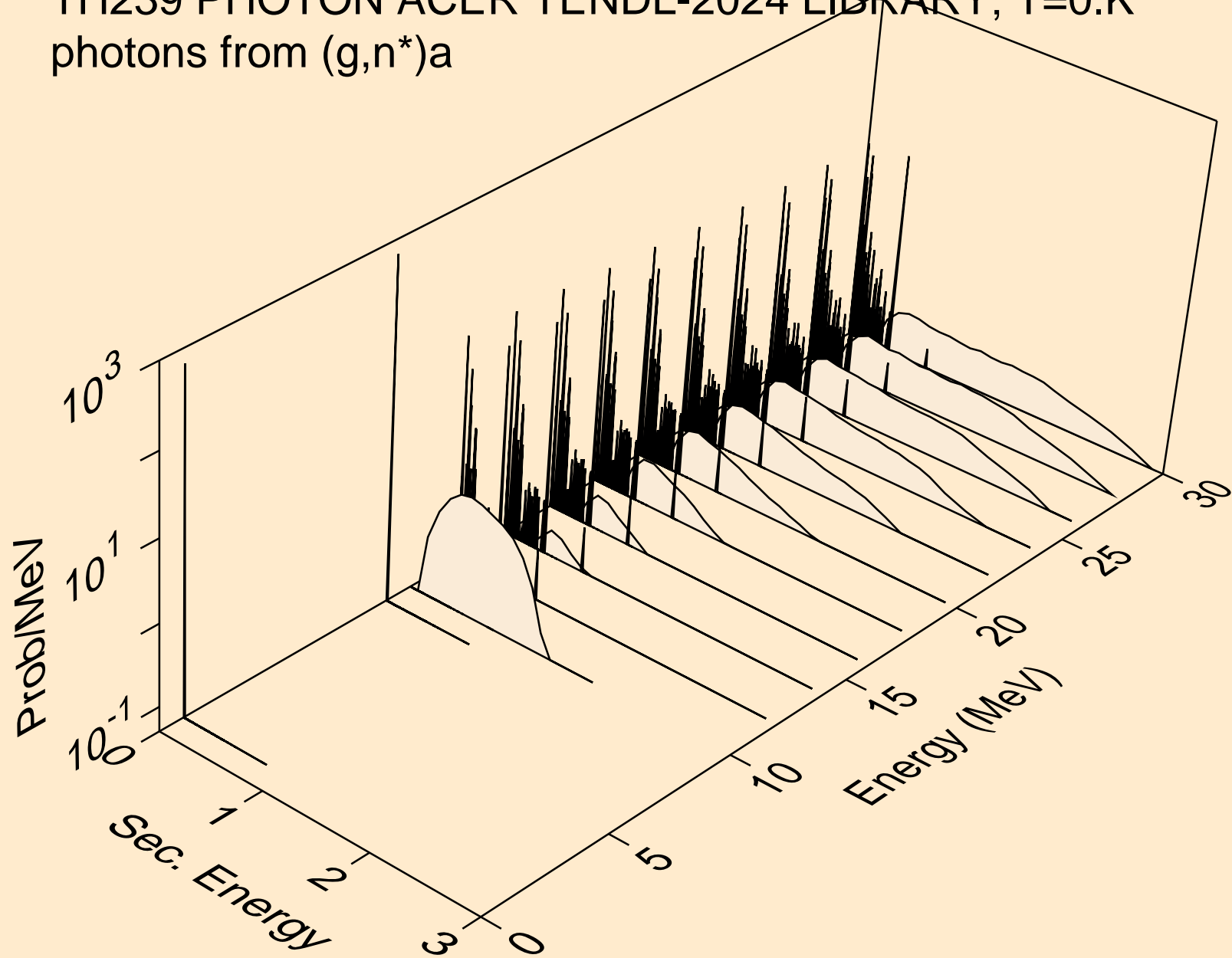

TH239 PHOTON ACER TENDL-2024 LIBRARY; T=0.K  
photons from (g,2n)a

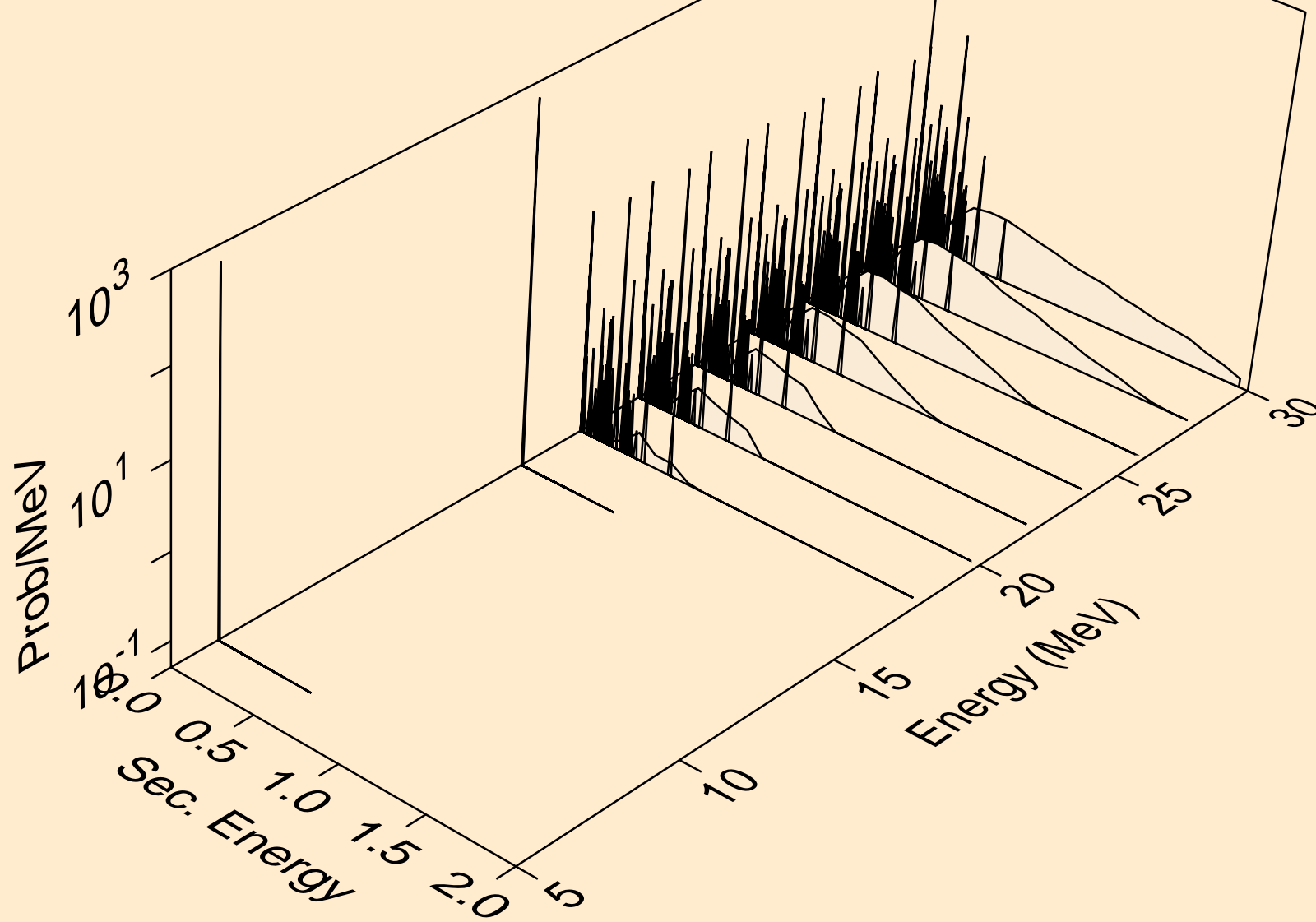

TH239 PHOTON ACER TENDL-2024 LIBRARY; T=0.K  
photons from (g,3n)a

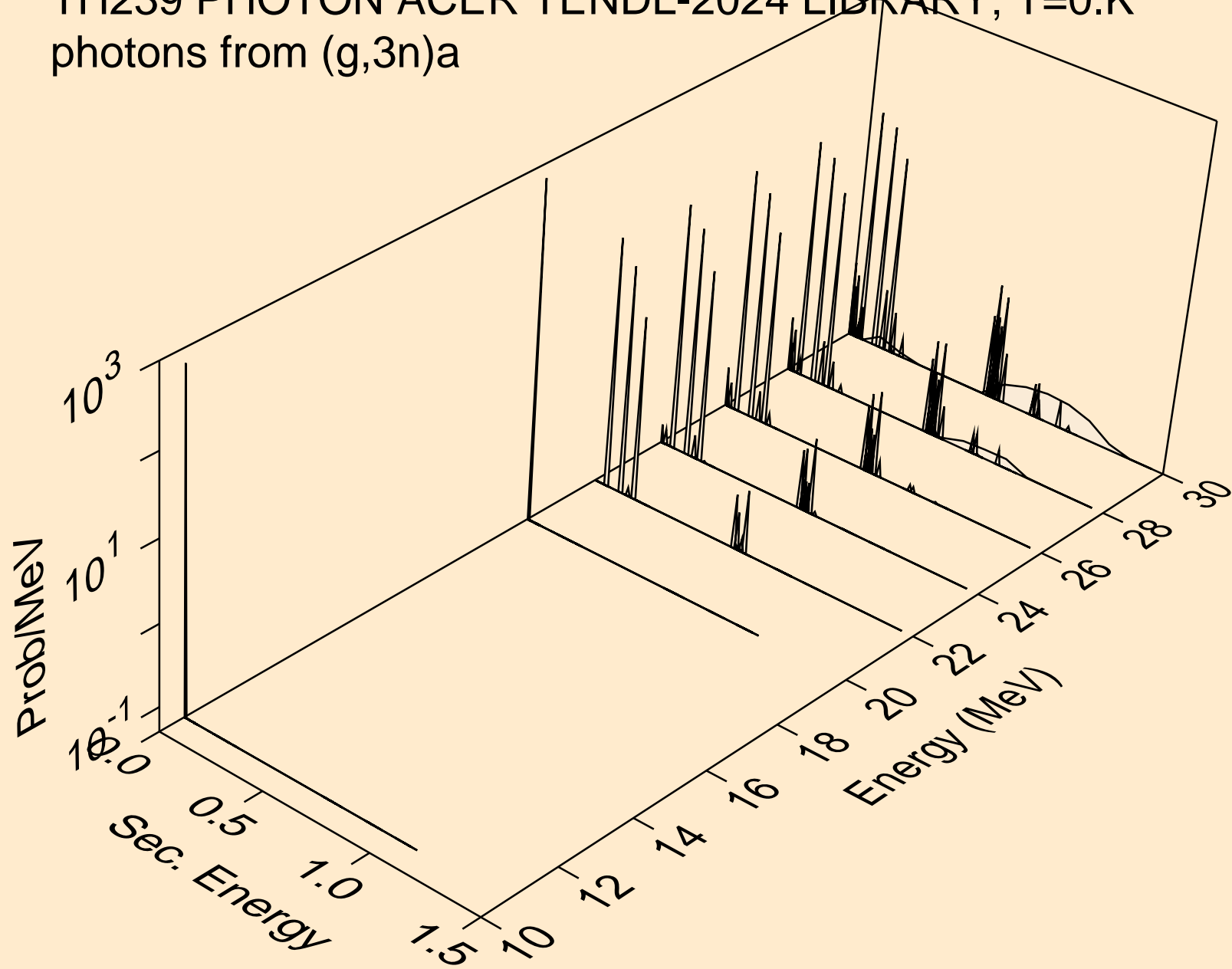

TH239 PHOTON ACER TENDL-2024 LIBRARY; T=0.K  
photons from (g,n\*)p

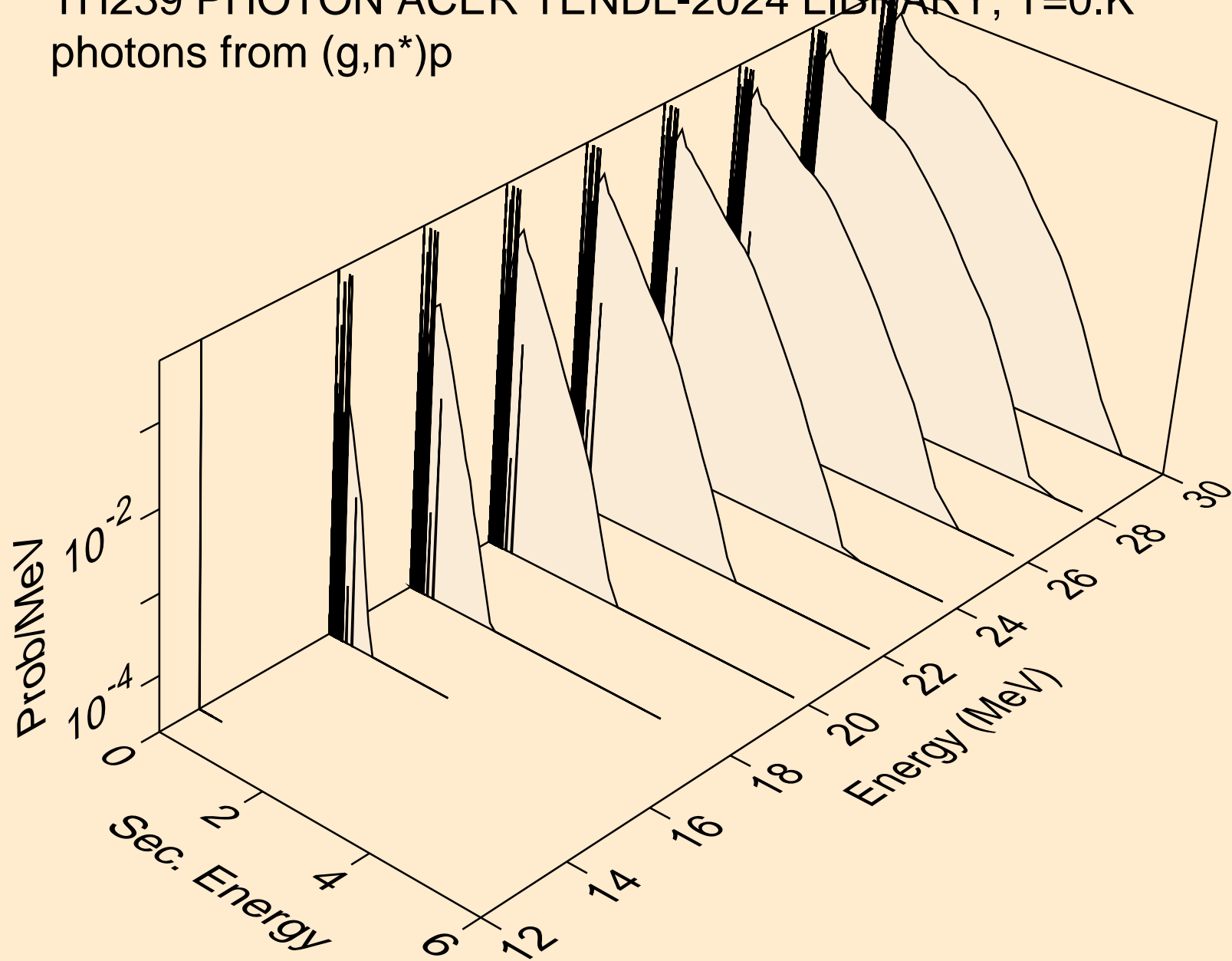

TH239 PHOTON ACER TENDL-2024 LIBRARY; T=0.K  
photons from (g,n\*)d

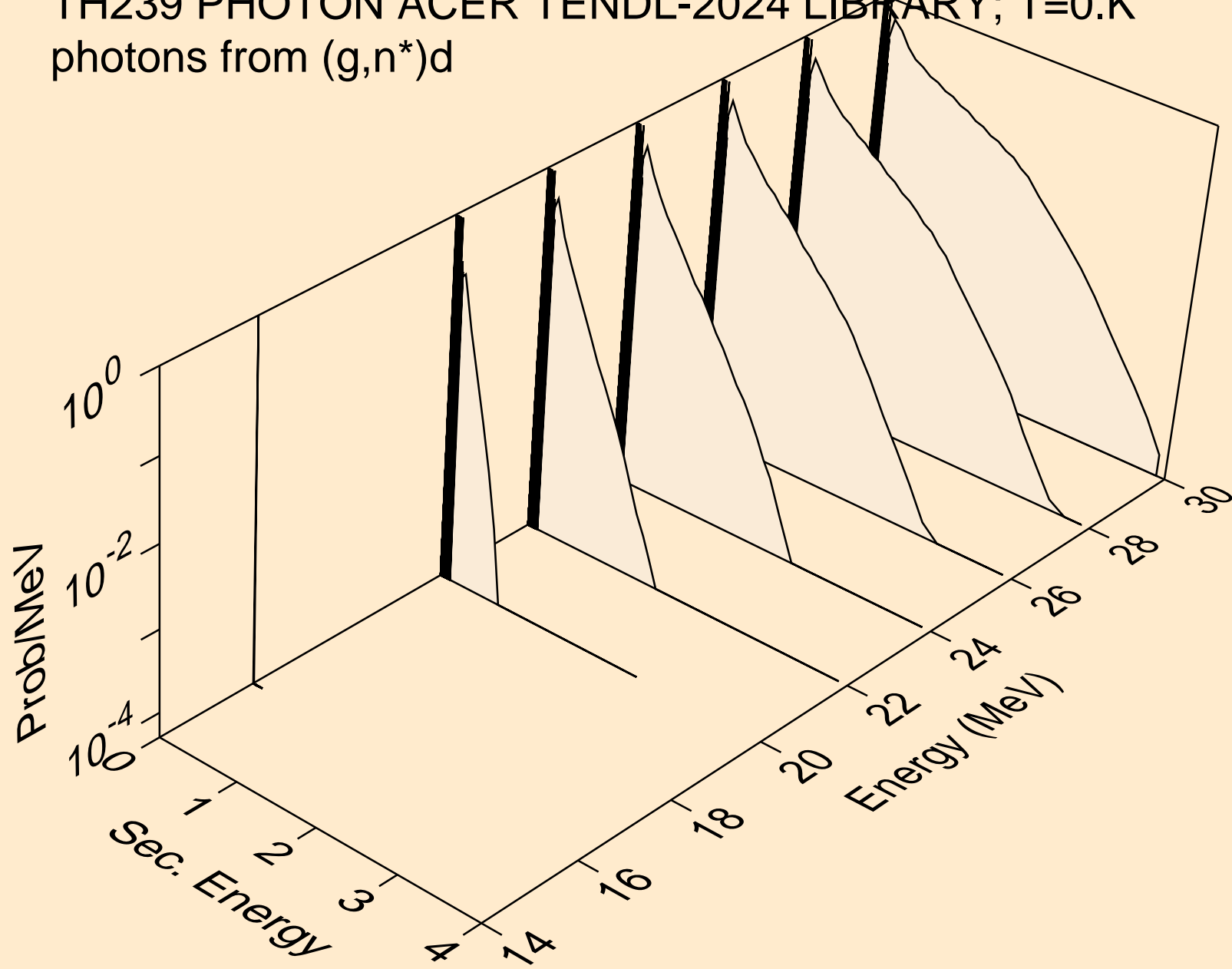

TH239 PHOTON ACER TENDL-2024 LIBRARY; T=0.K  
photons from (g,n\*)t

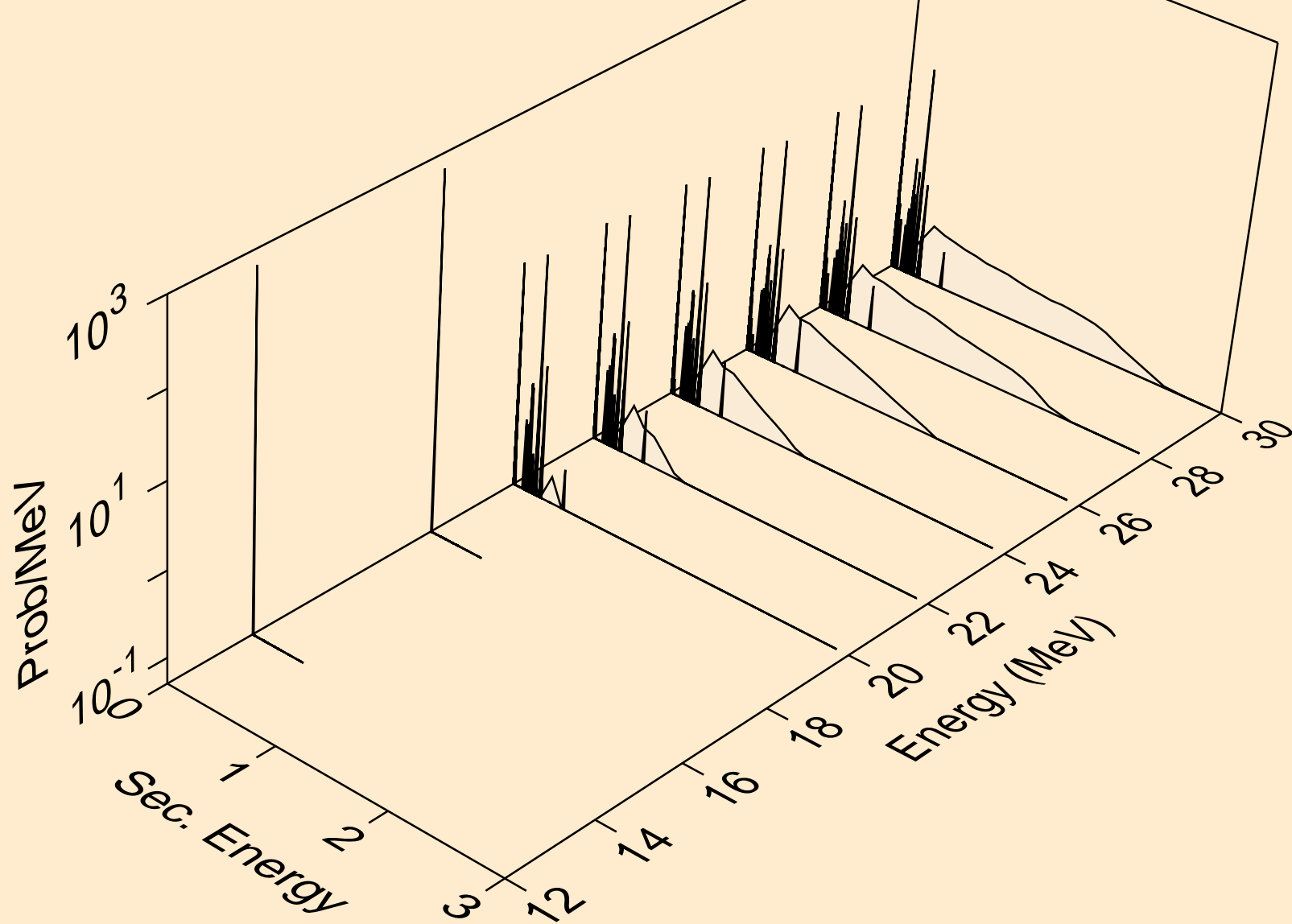

TH239 PHOTON ACER TENDL-2024 LIBRARY; T=0.K  
photons from (g,4n)

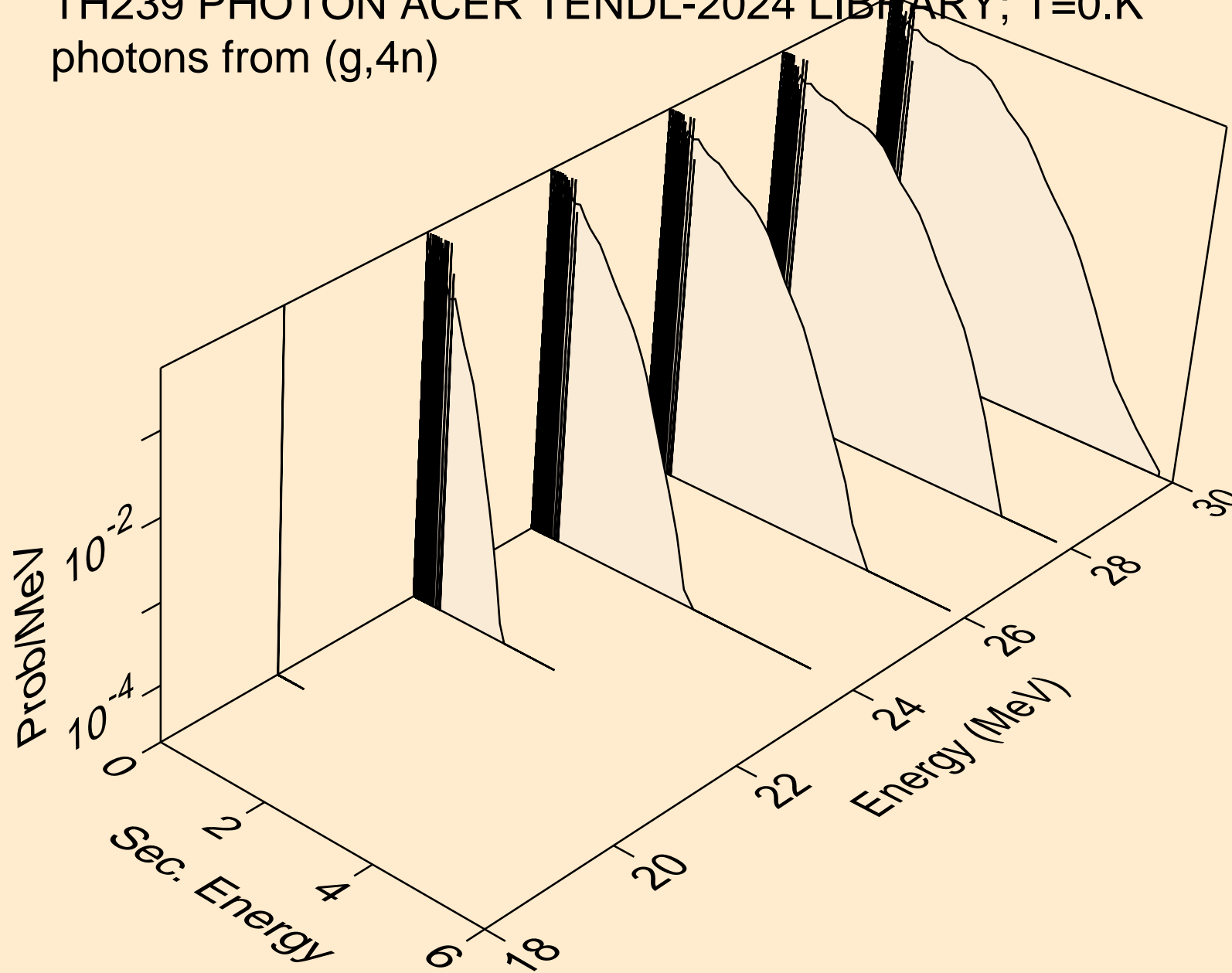

TH239 PHOTON ACER TENDL-2024 LIBRARY; T=0.K  
photons from (g,2np)

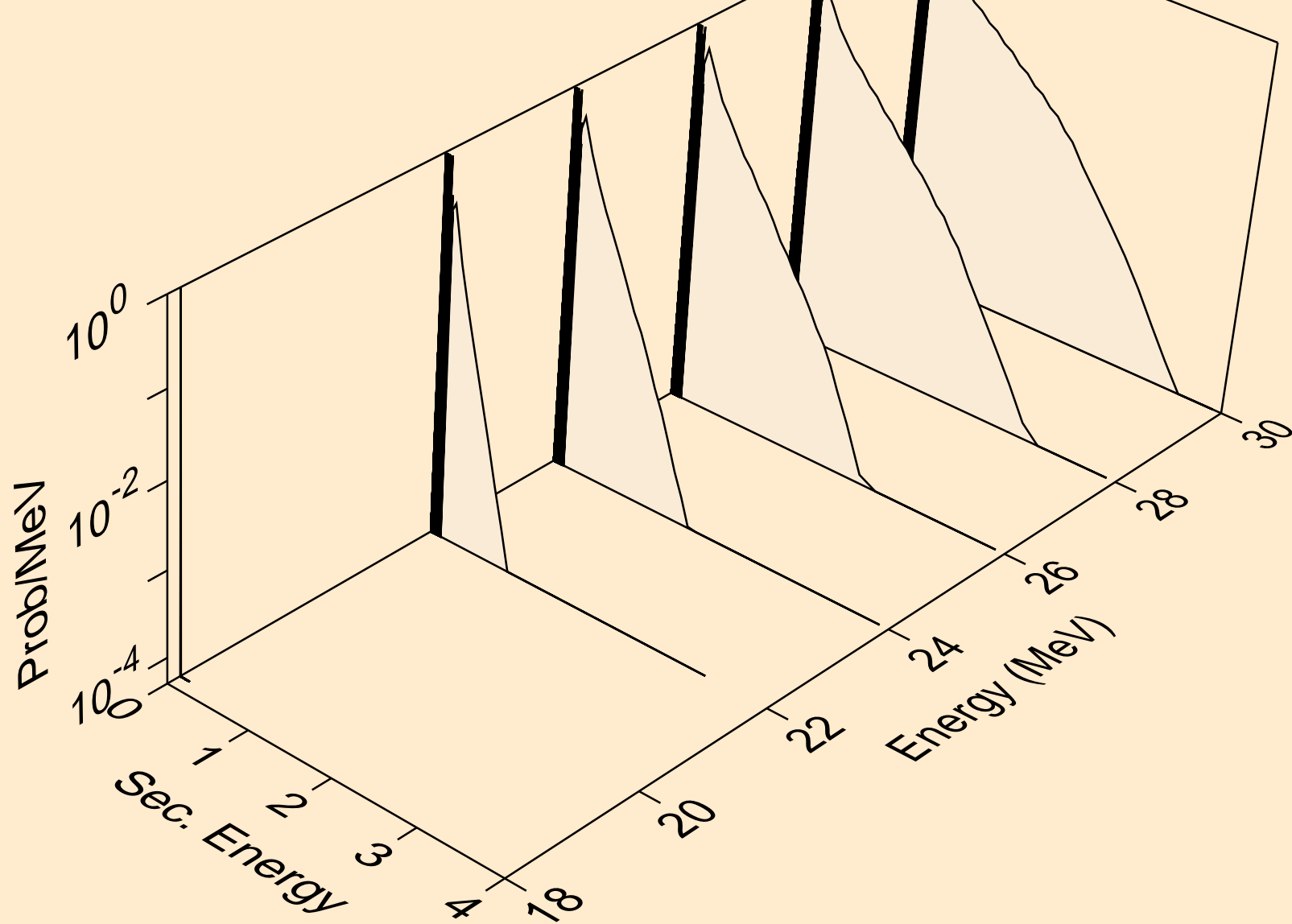

TH239 PHOTON ACER TENDL-2024 LIBRARY; T=0.K  
photons from (g,3np)

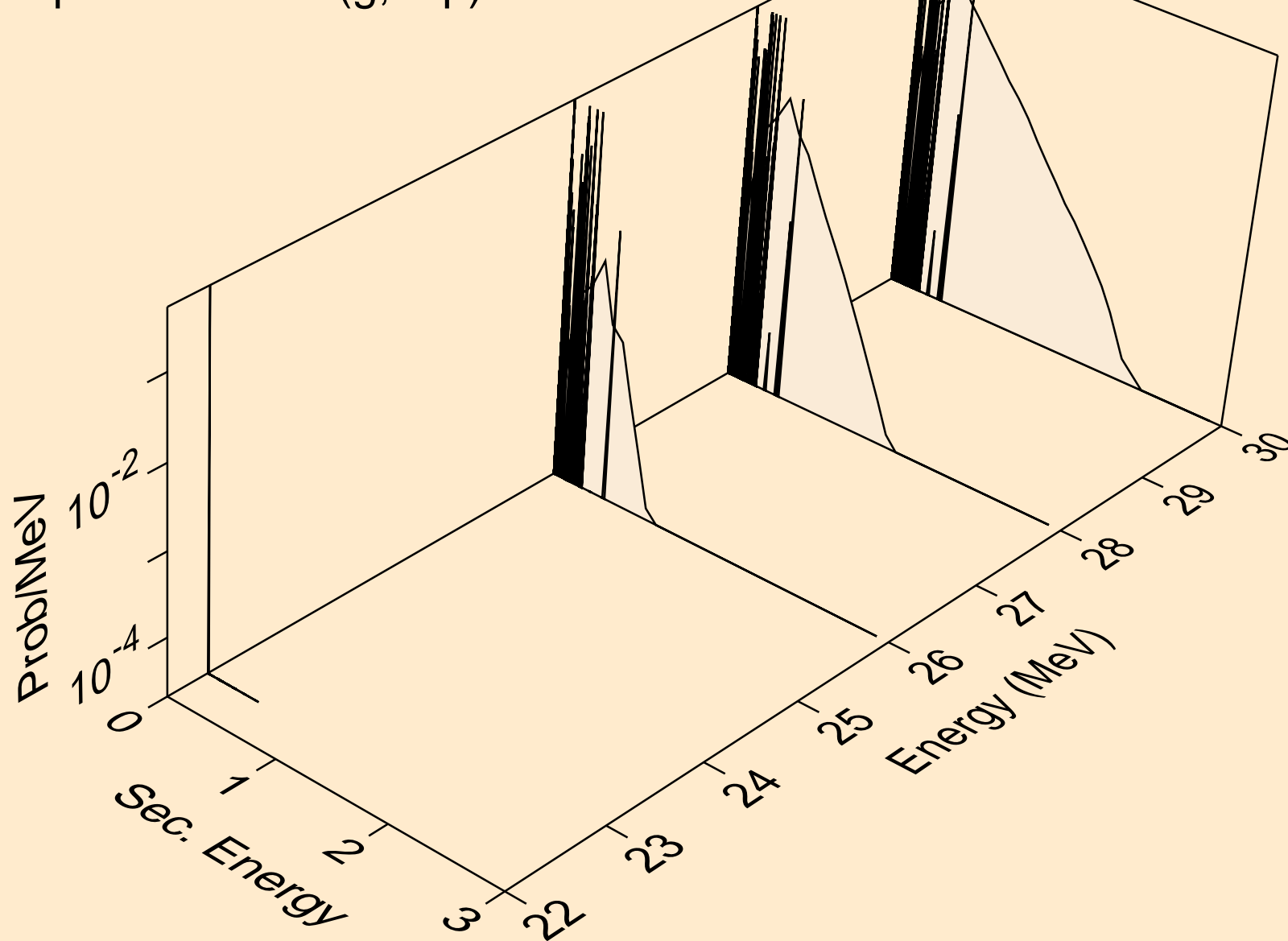

TH239 PHOTON ACER TENDL-2024 LIBRARY; T=0.K  
photons from (g,n\*c)

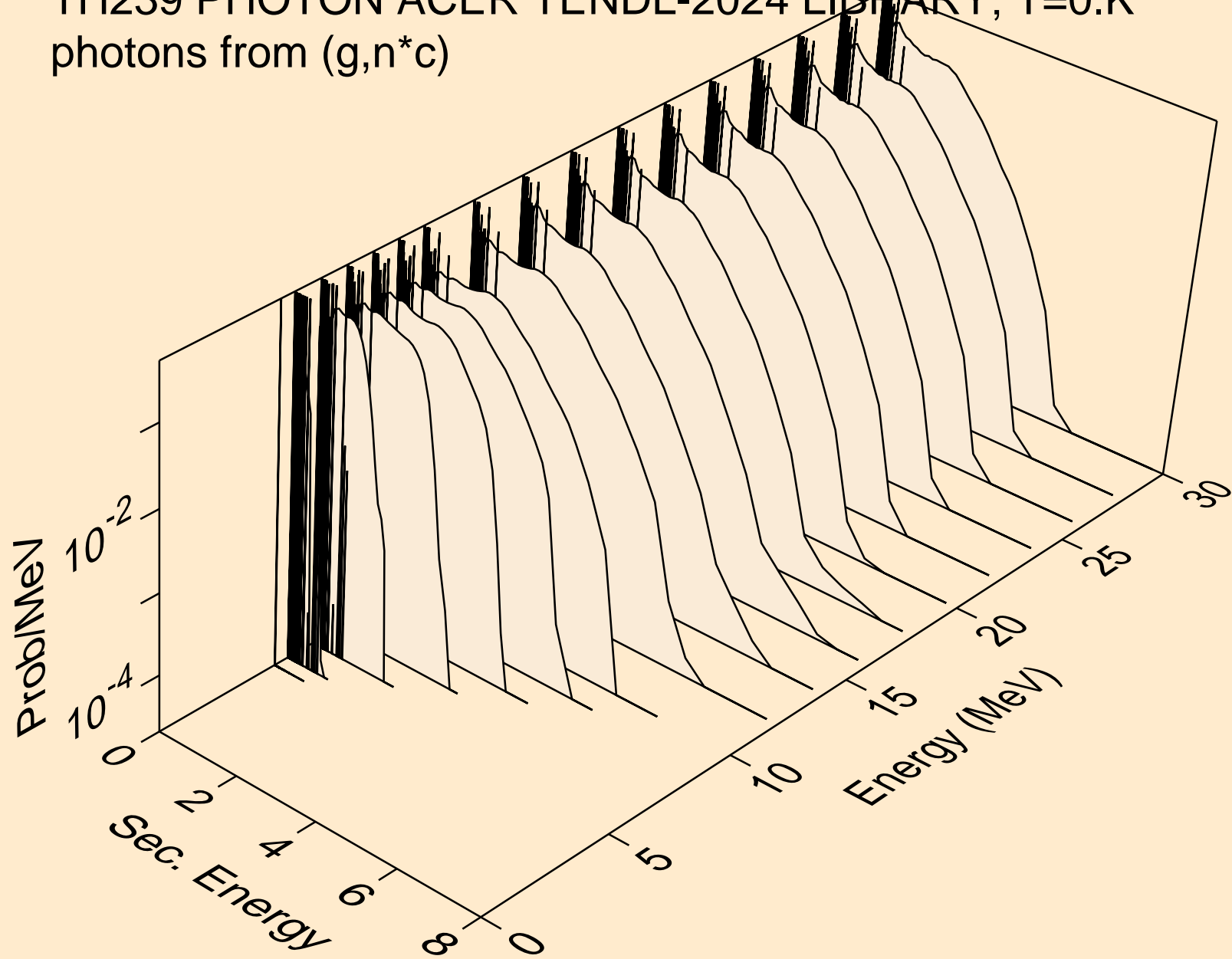

TH239 PHOTON ACER TENDL-2024 LIBRARY; T=0.K  
photons from (g,gma)

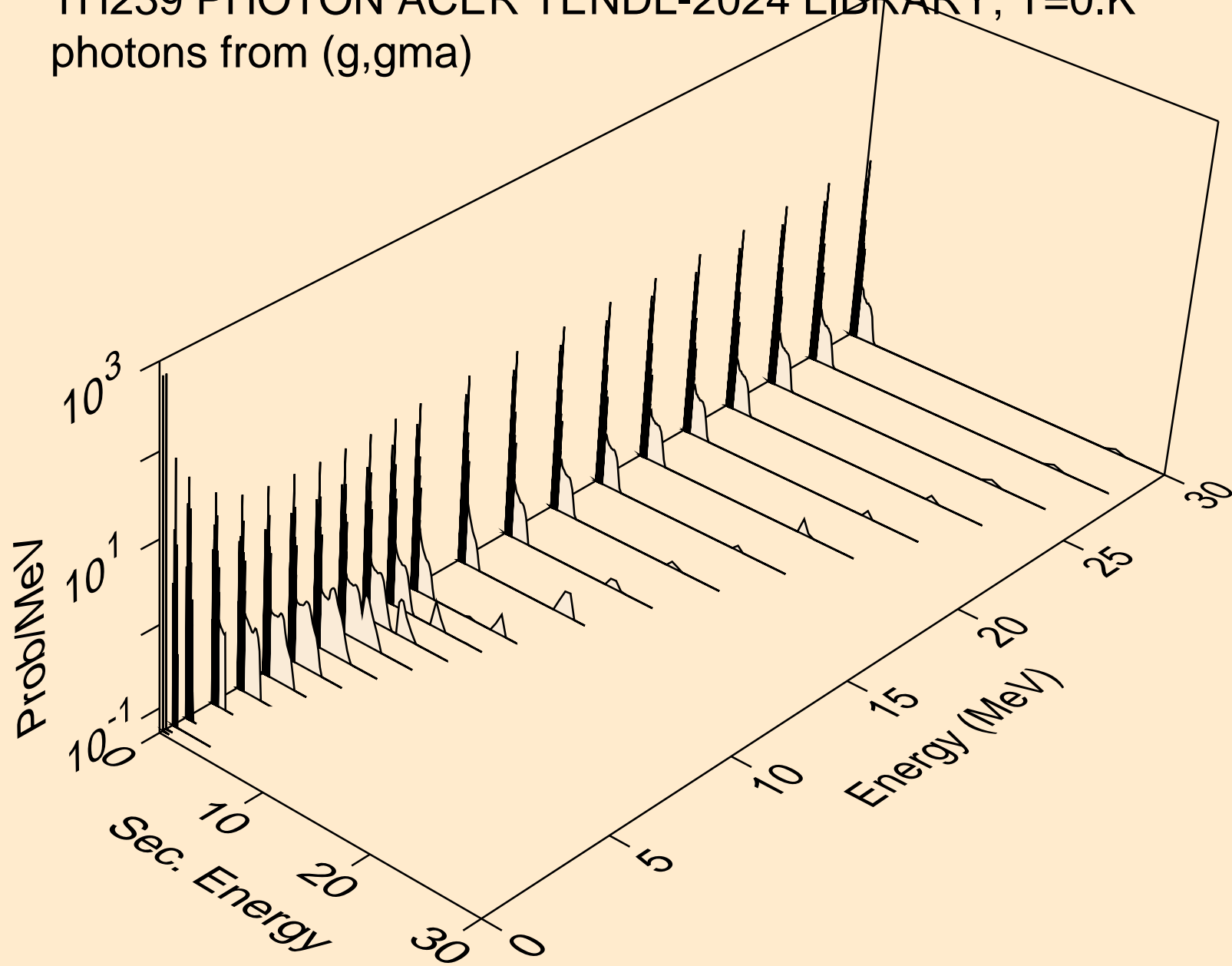

TH239 PHOTON ACER TENDL-2024 LIBRARY; T=0.K  
photons from (g,p)

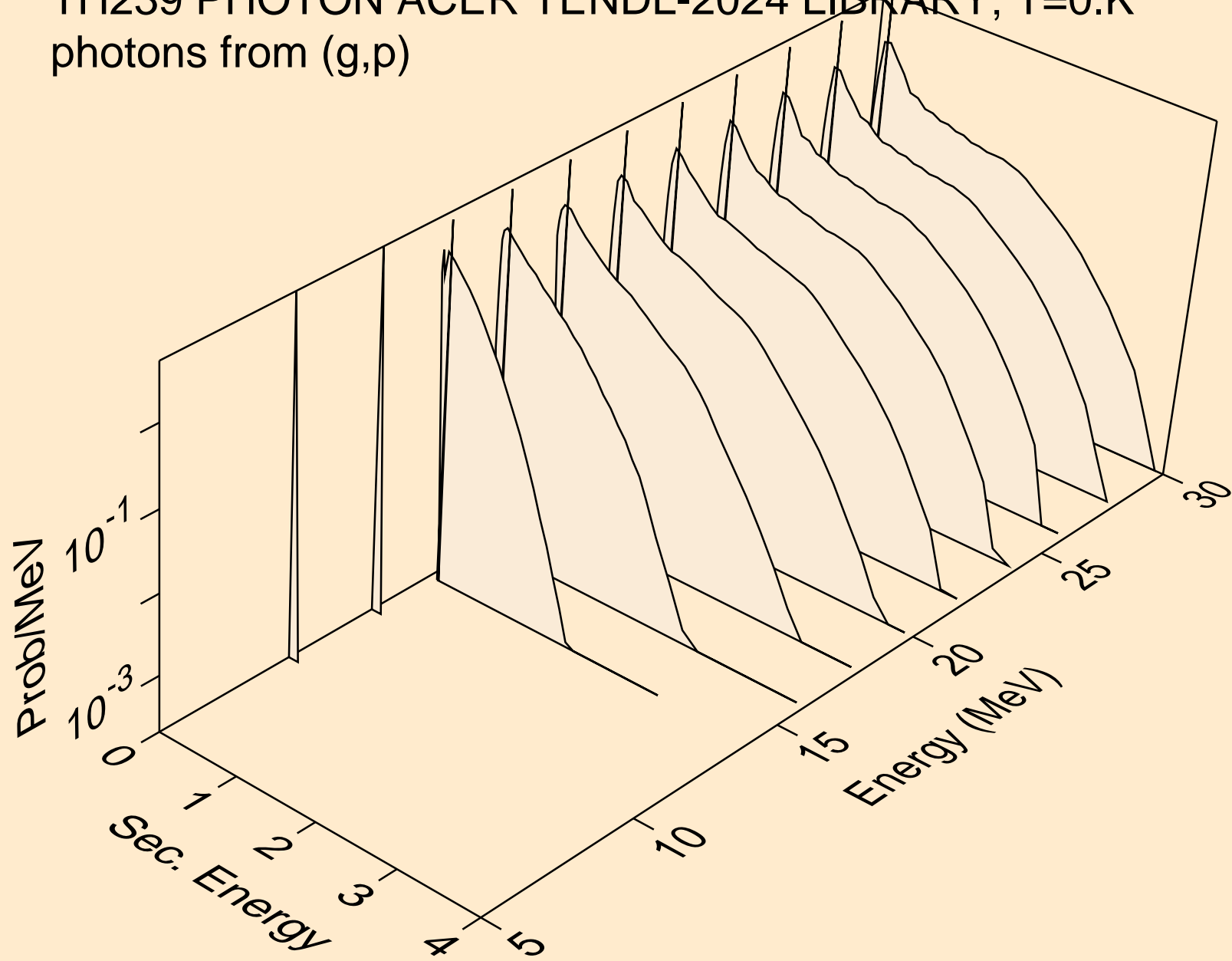

TH239 PHOTON ACER TENDL-2024 LIBRARY; T=0.K  
photons from (g,d)

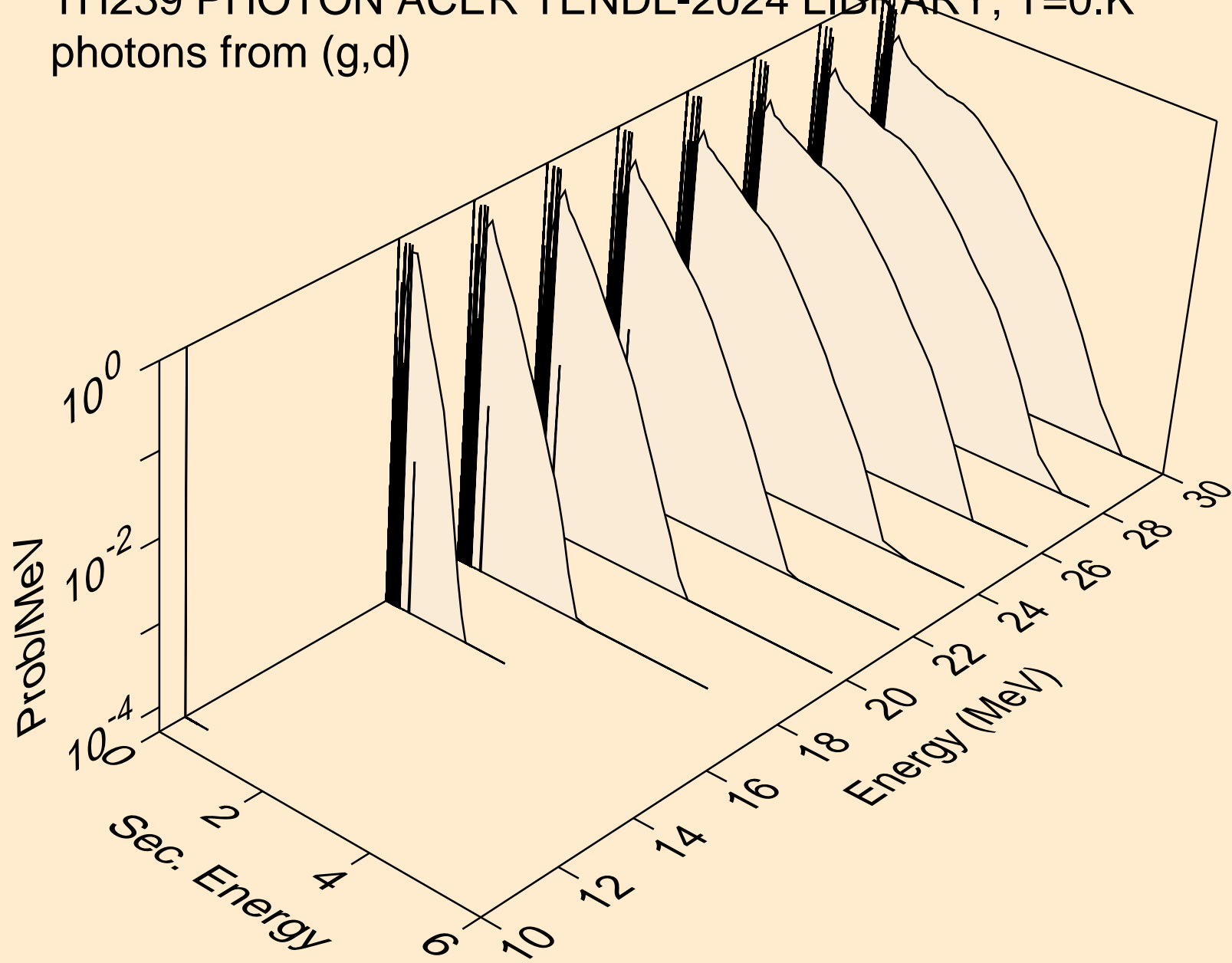

TH239 PHOTON ACER TENDL-2024 LIBRARY; T=0.K  
photons from (g,t)

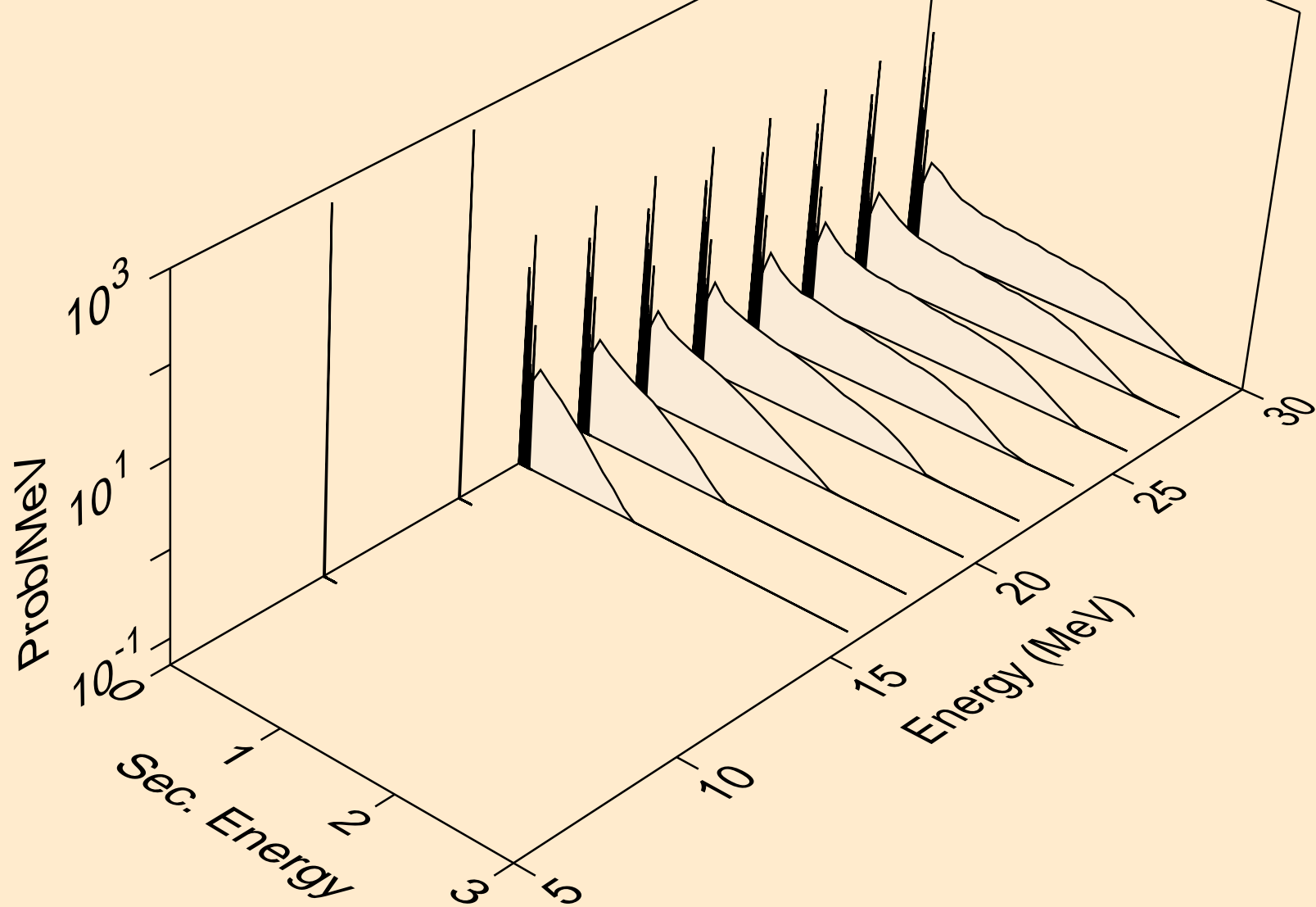

TH239 PHOTON ACER TENDL-2024 LIBRARY; T=0.K  
photons from (g,a)

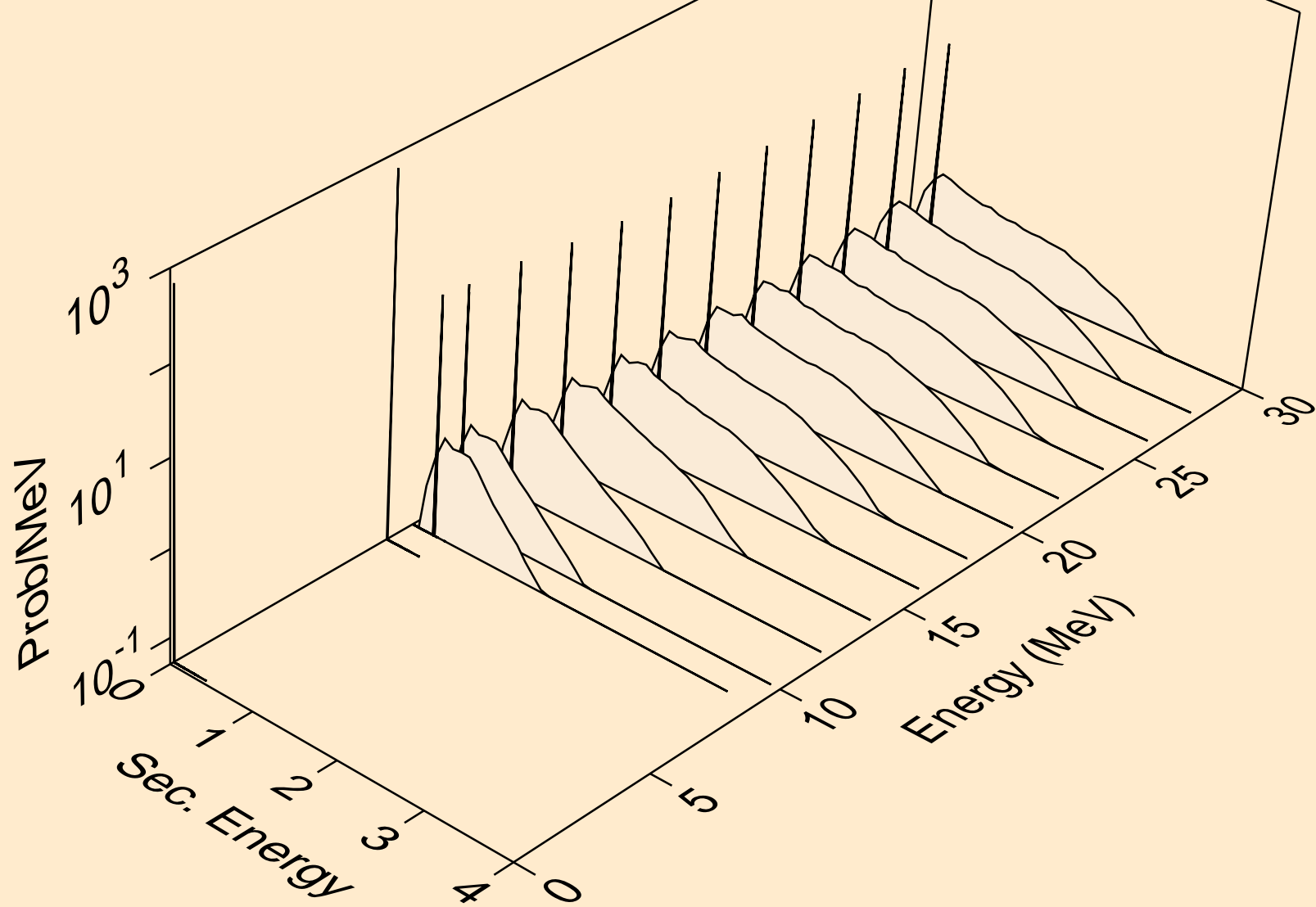

TH239 PHOTON ACER TENDL-2024 LIBRARY; T=0.K  
protons from (g,x)

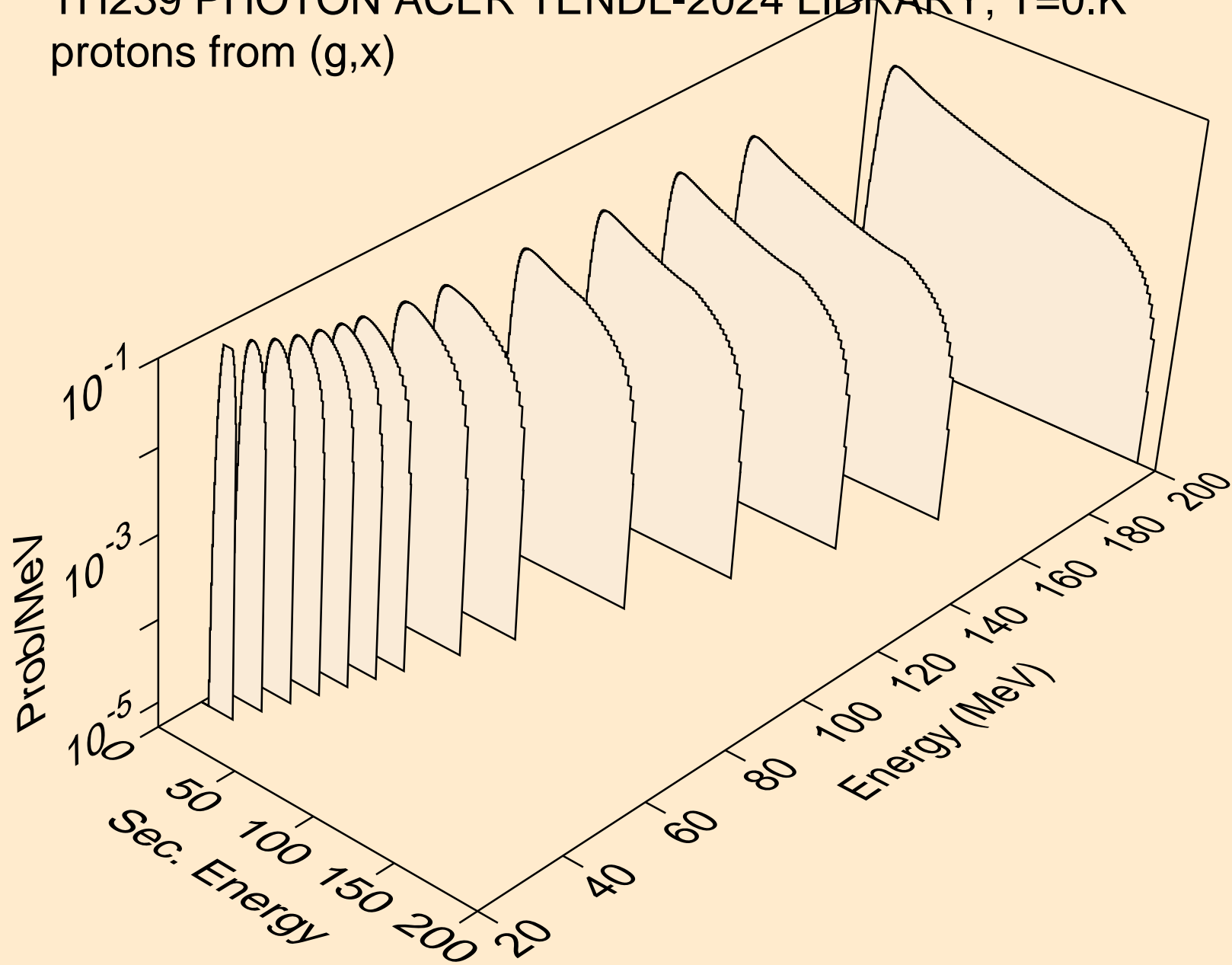

TH239 PHOTON ACER TENDL-2024 LIBRARY; T=0.K  
protons from (g,n\*)p

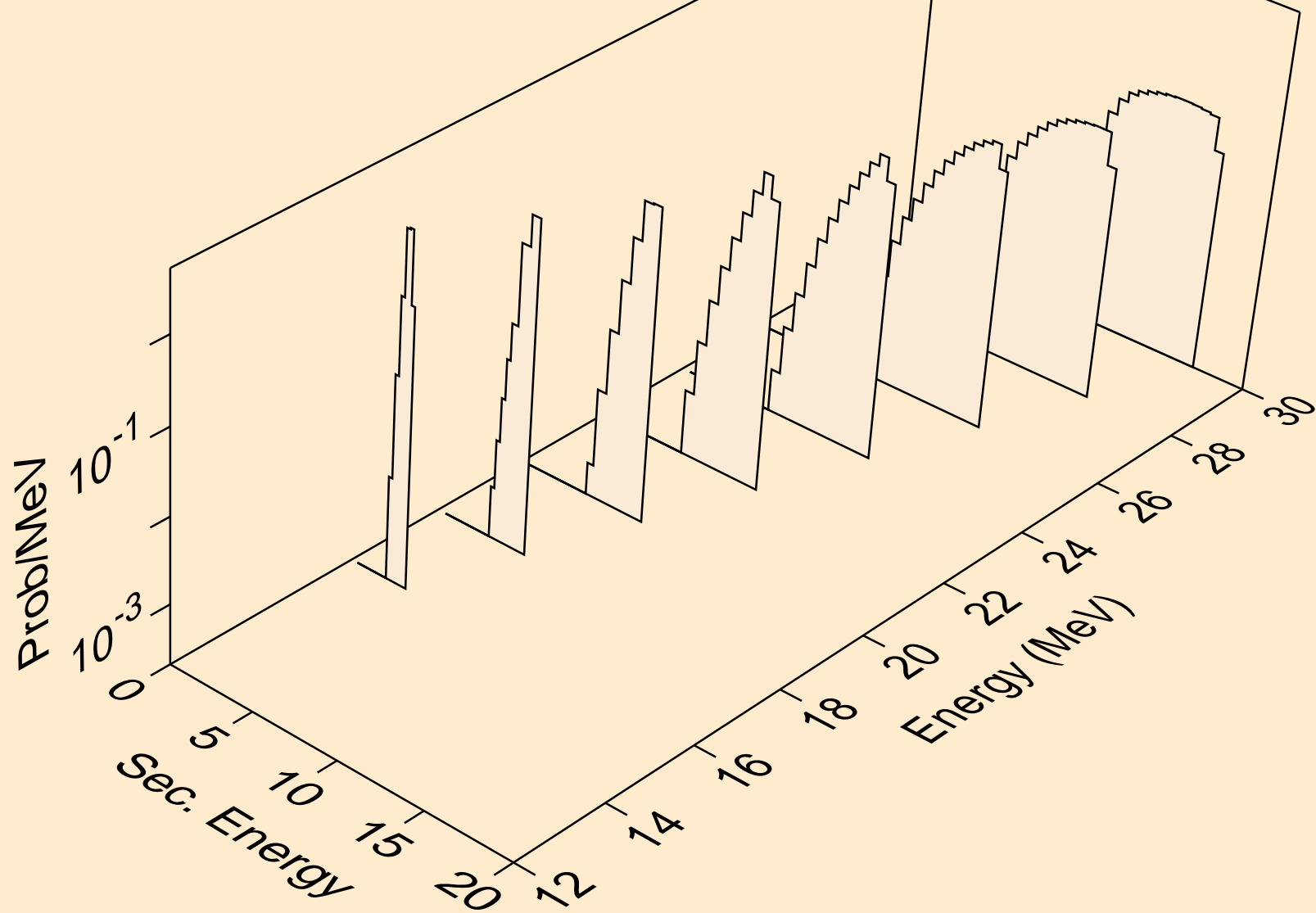

TH239 PHOTON ACER TENDL-2024 LIBRARY; T=0.K  
protons from (g,2np)

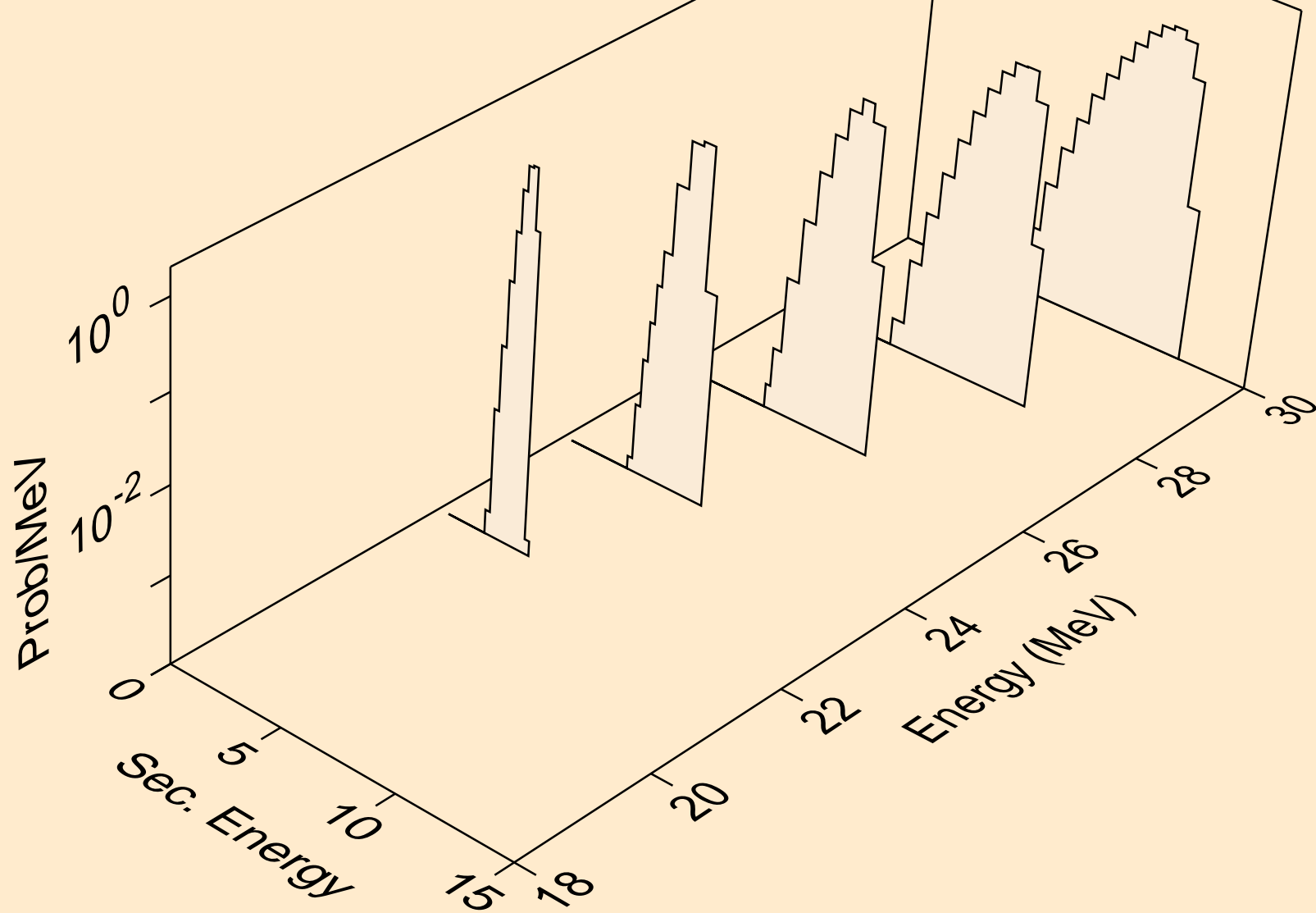

TH239 PHOTON ACER TENDL-2024 LIBRARY; T=0.K  
protons from (g,3np)

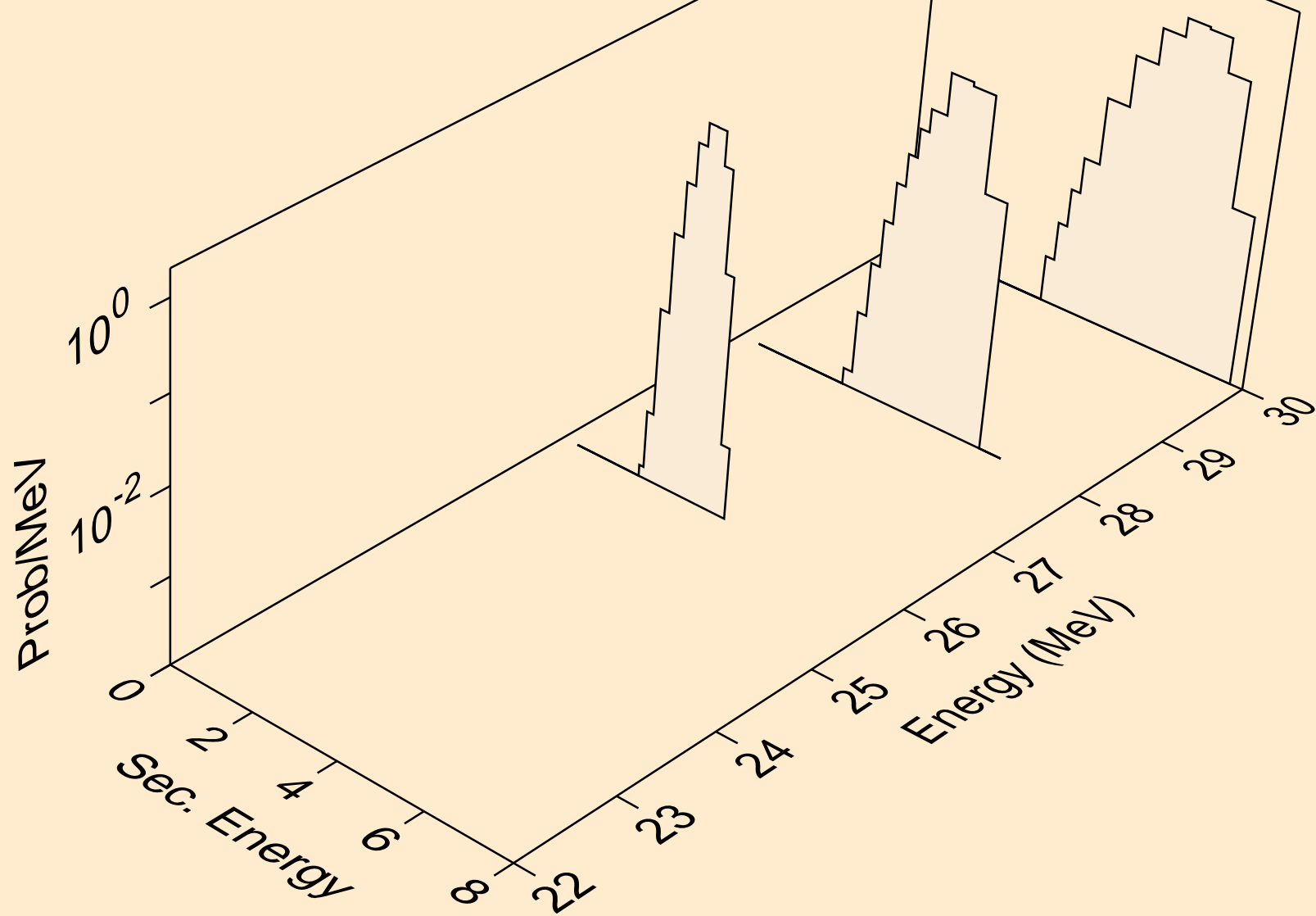

TH239 PHOTON ACER TENDL-2024 LIBRARY; T=0.K  
protons from (g,p)

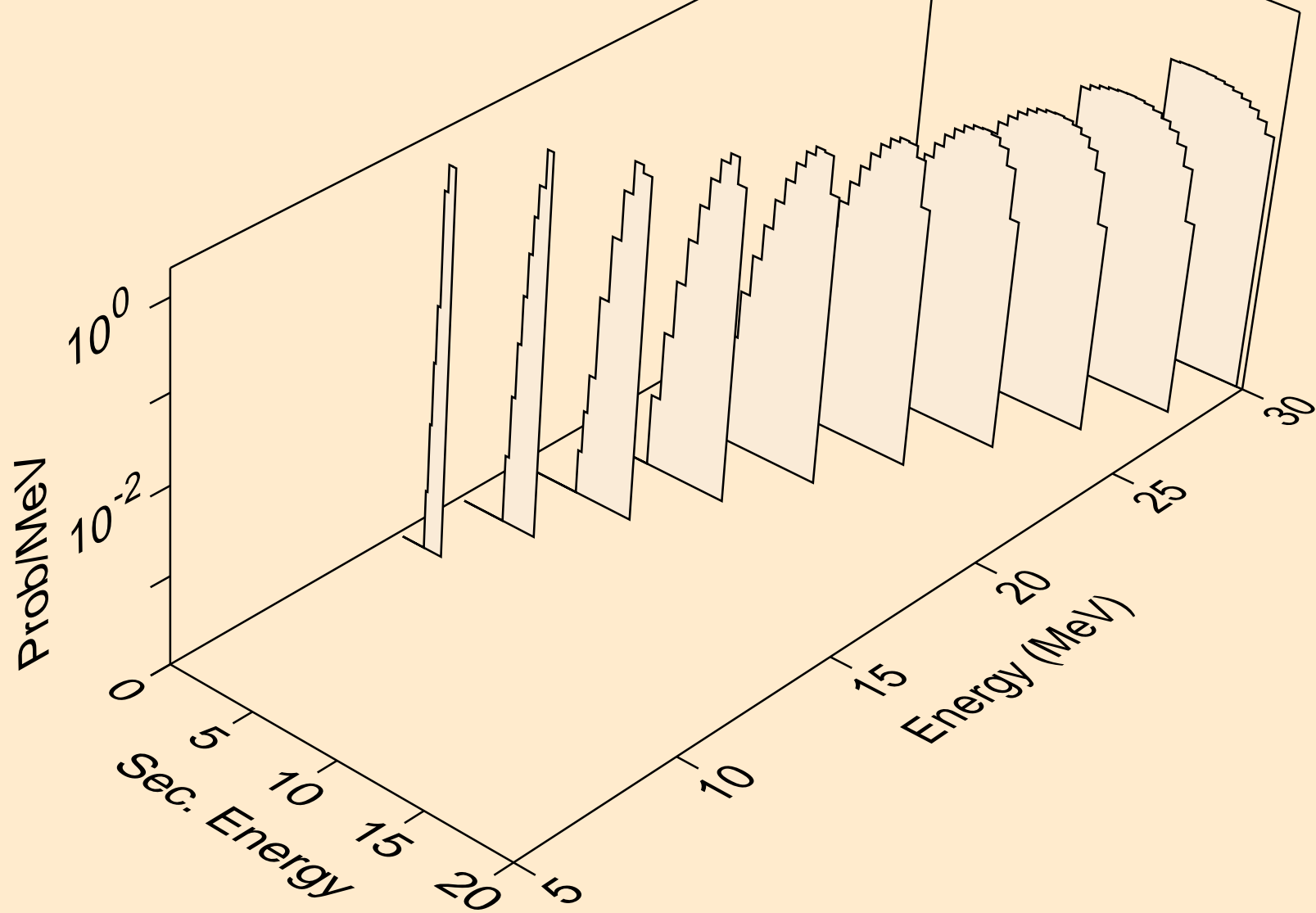

TH239 PHOTON ACER TENDL-2024 LIBRARY; T=0.K  
deuterons from (g,x)

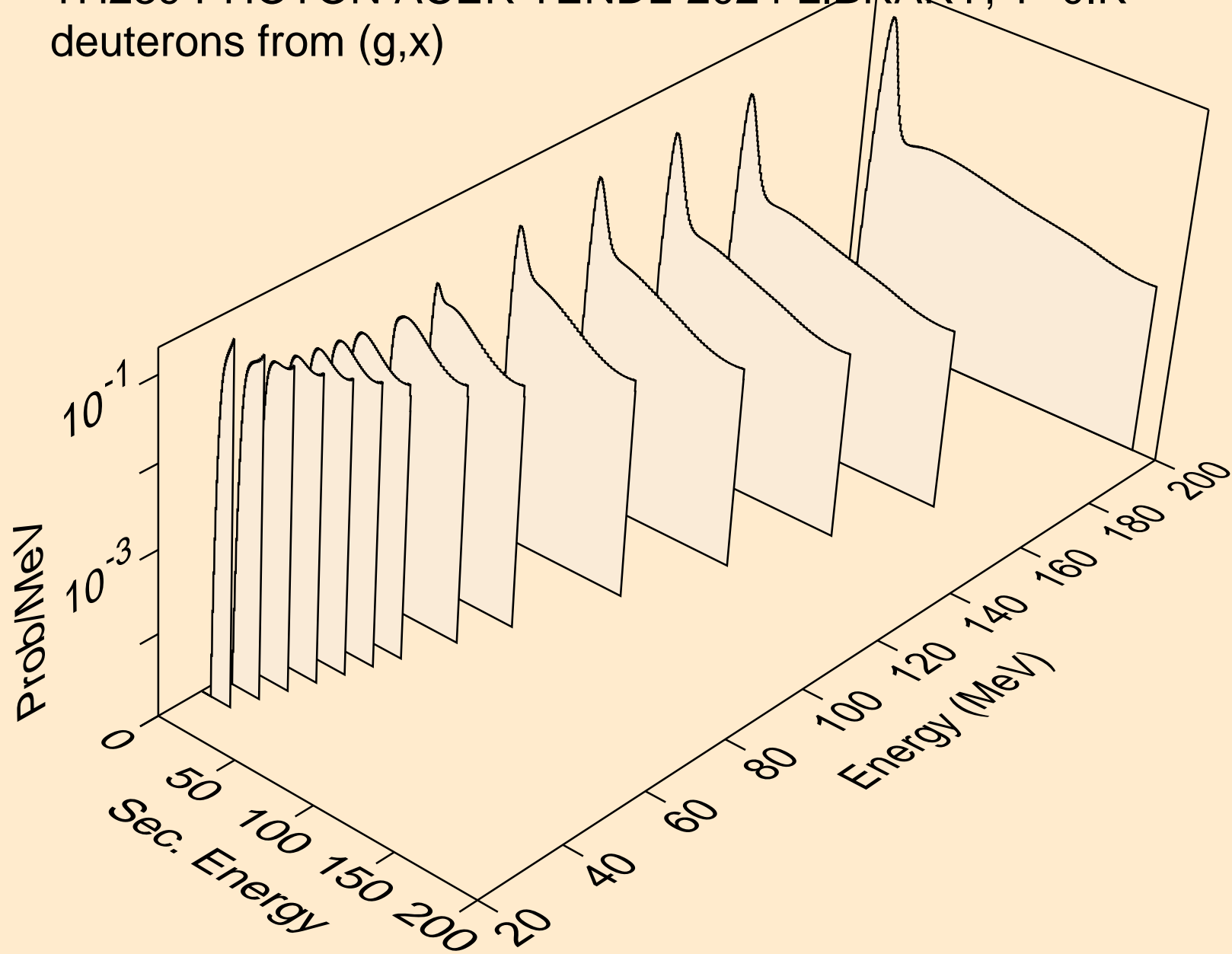

TH239 PHOTON ACER TENDL-2024 LIBRARY; T=0.K  
deuterons from (g,2nd)

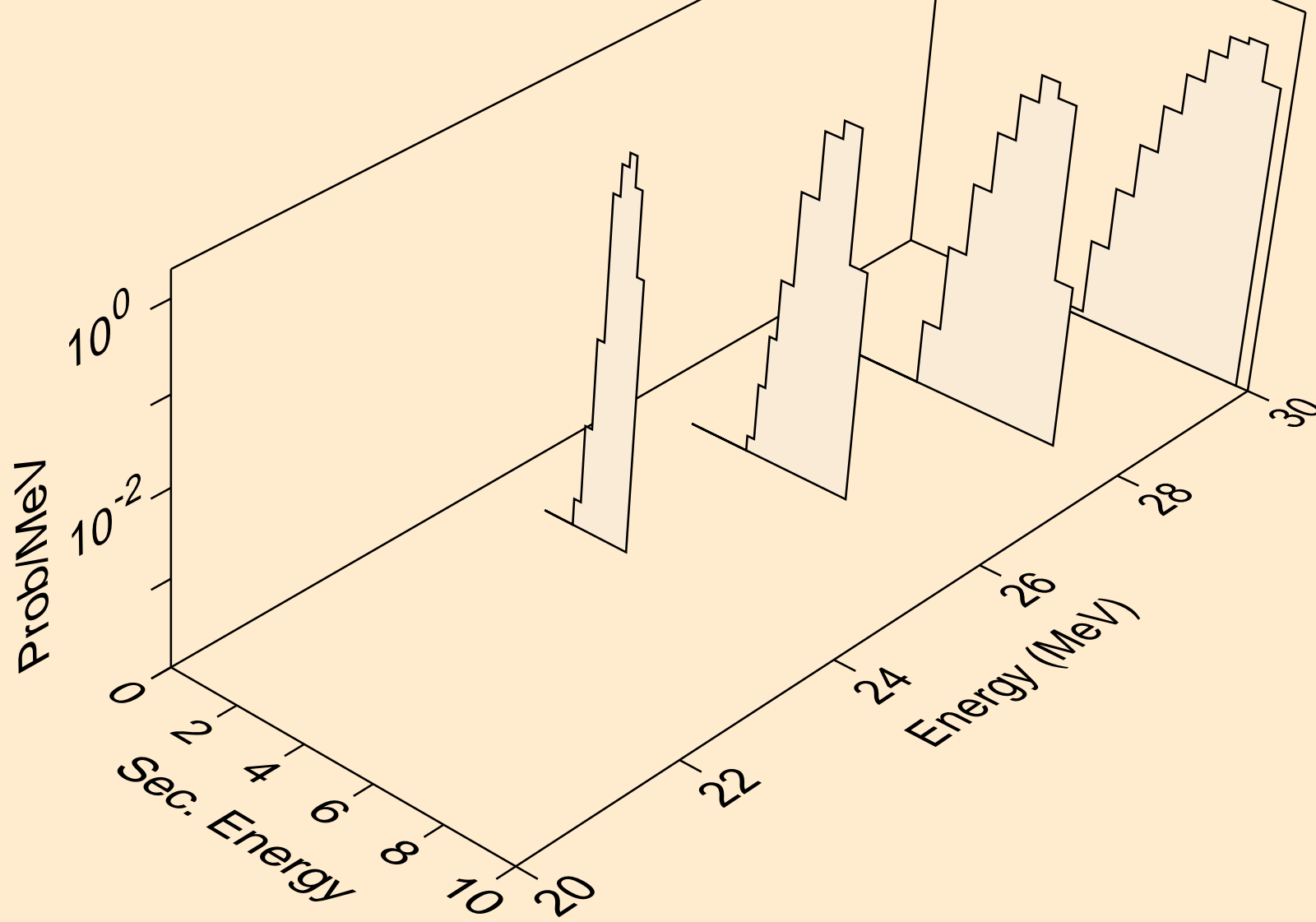

TH239 PHOTON ACER TENDL-2024 LIBRARY; T=0.K  
deuterons from (g,n\*)d

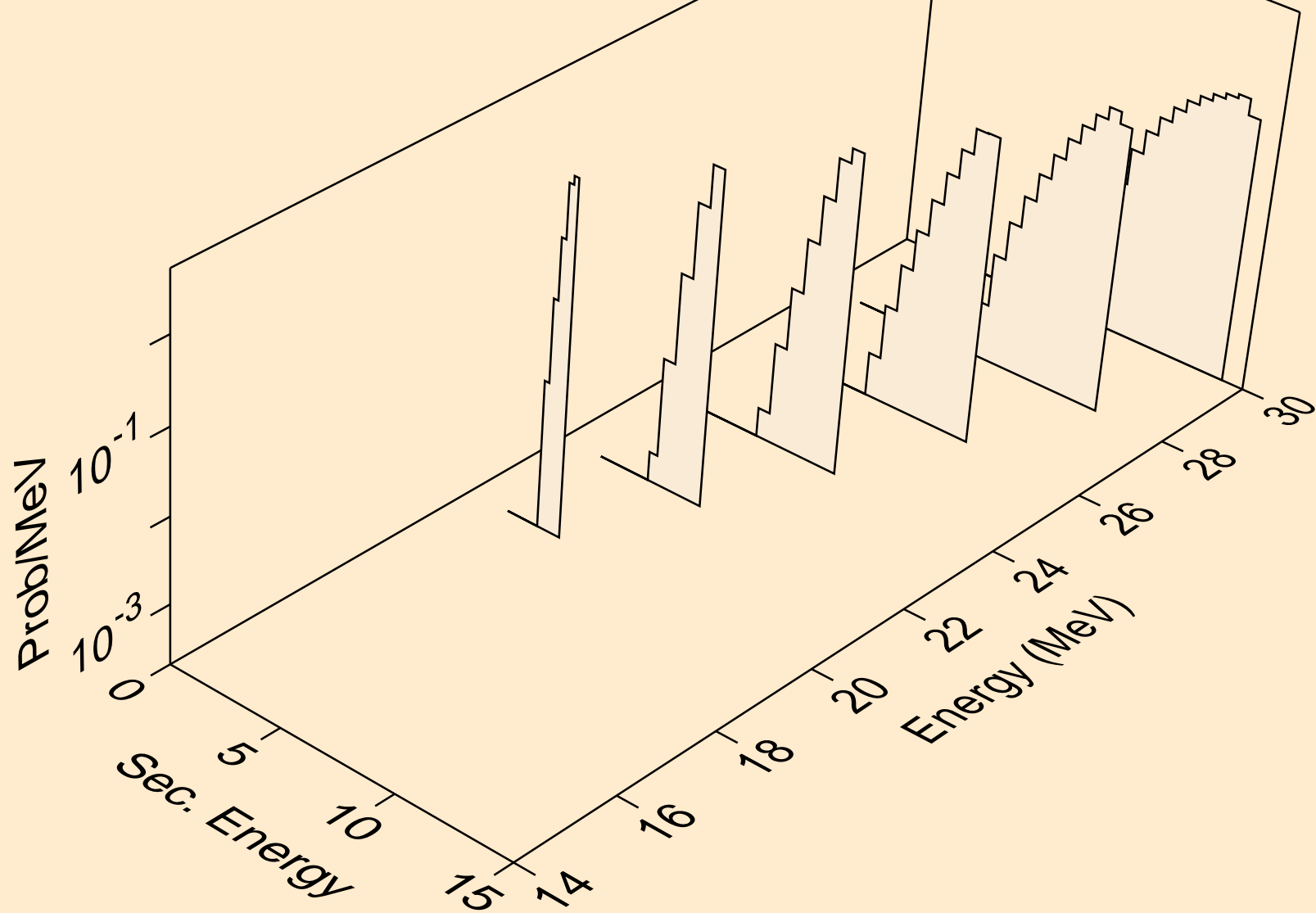

TH239 PHOTON ACER TENDL-2024 LIBRARY; T=0.K  
deuterons from (g,d)

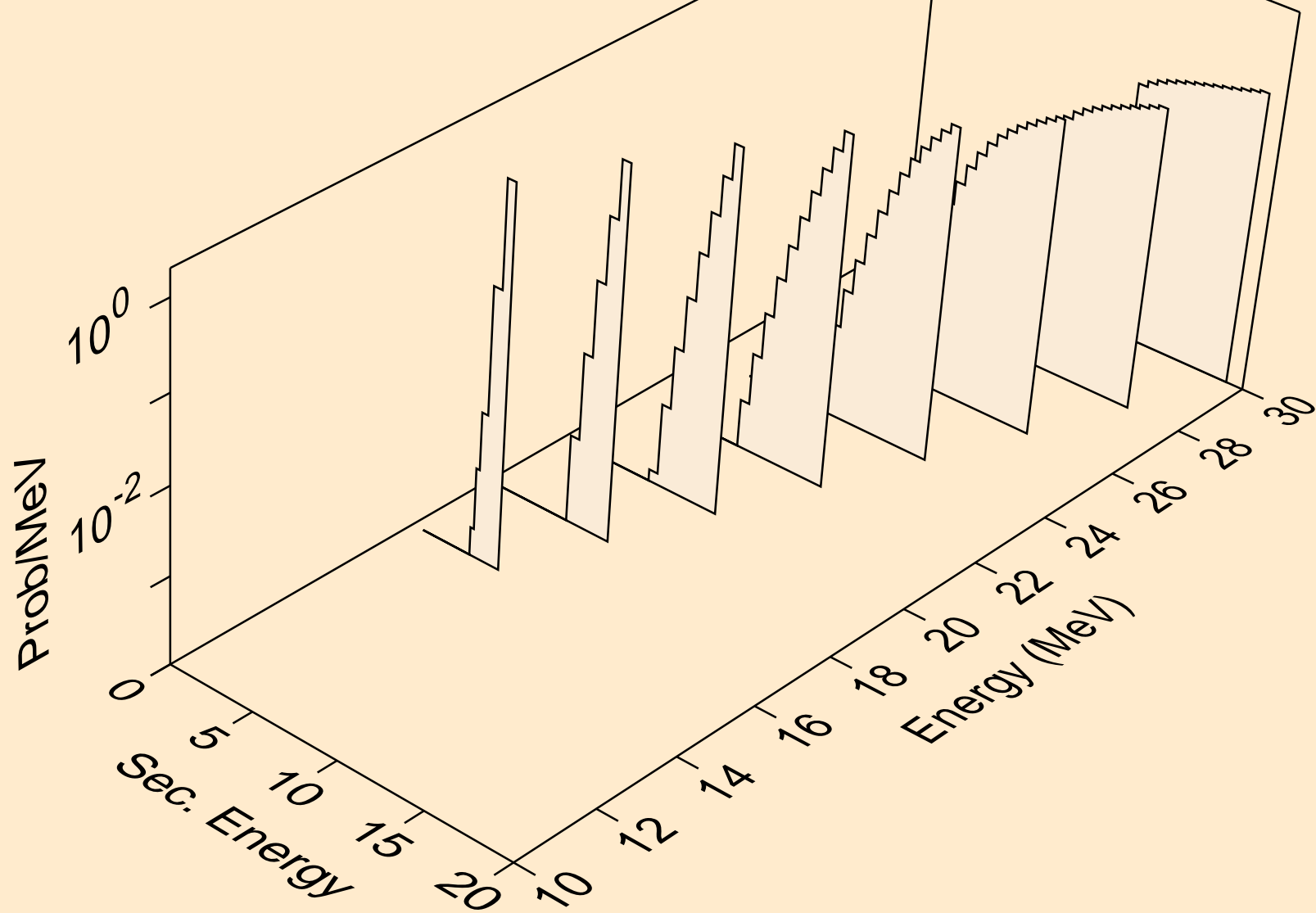

TH239 PHOTON ACER TENDL-2024 LIBRARY; T=0.K  
tritons from (g,x)

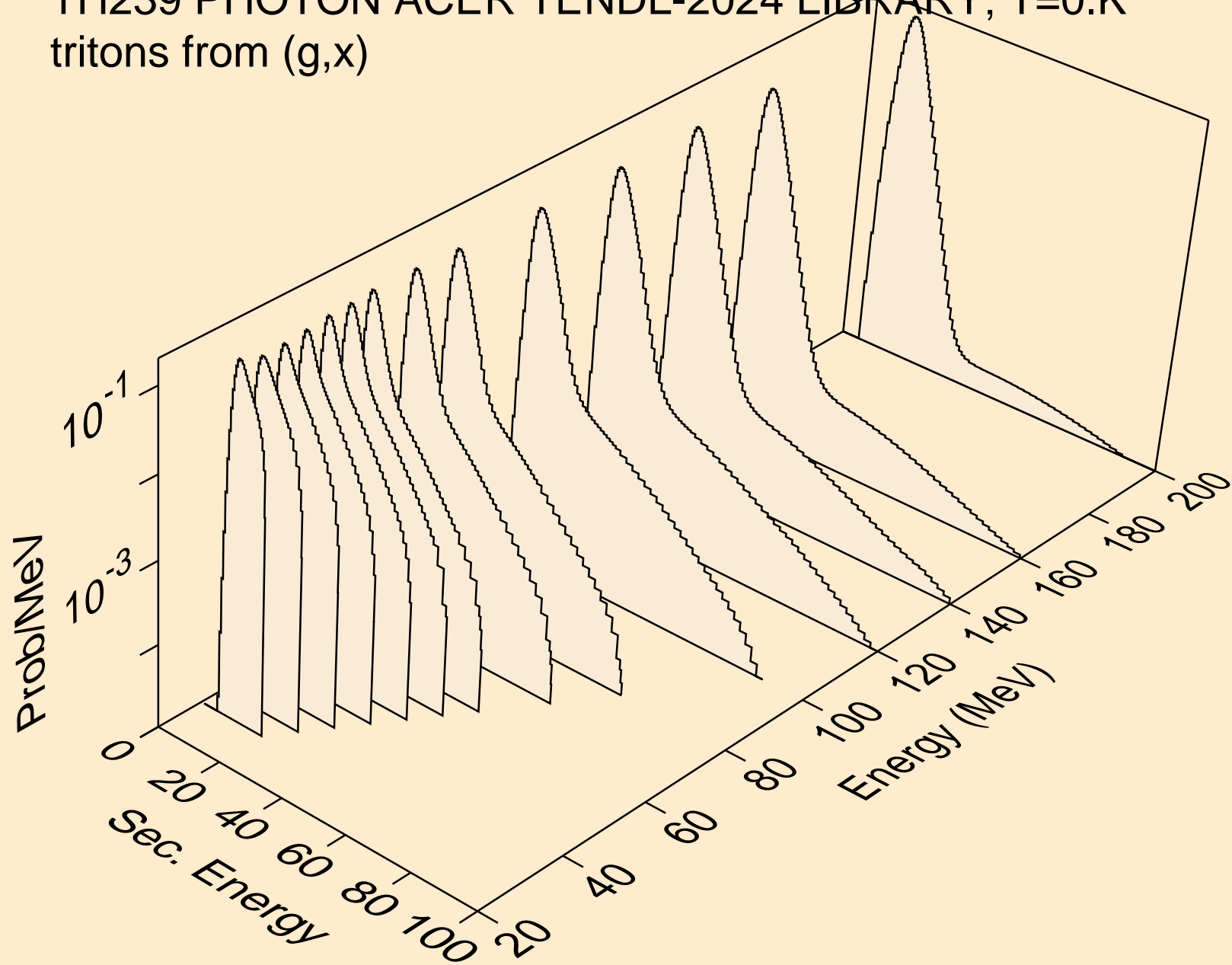

TH239 PHOTON ACER TENDL-2024 LIBRARY; T=0.K  
tritons from (g,n\*)t

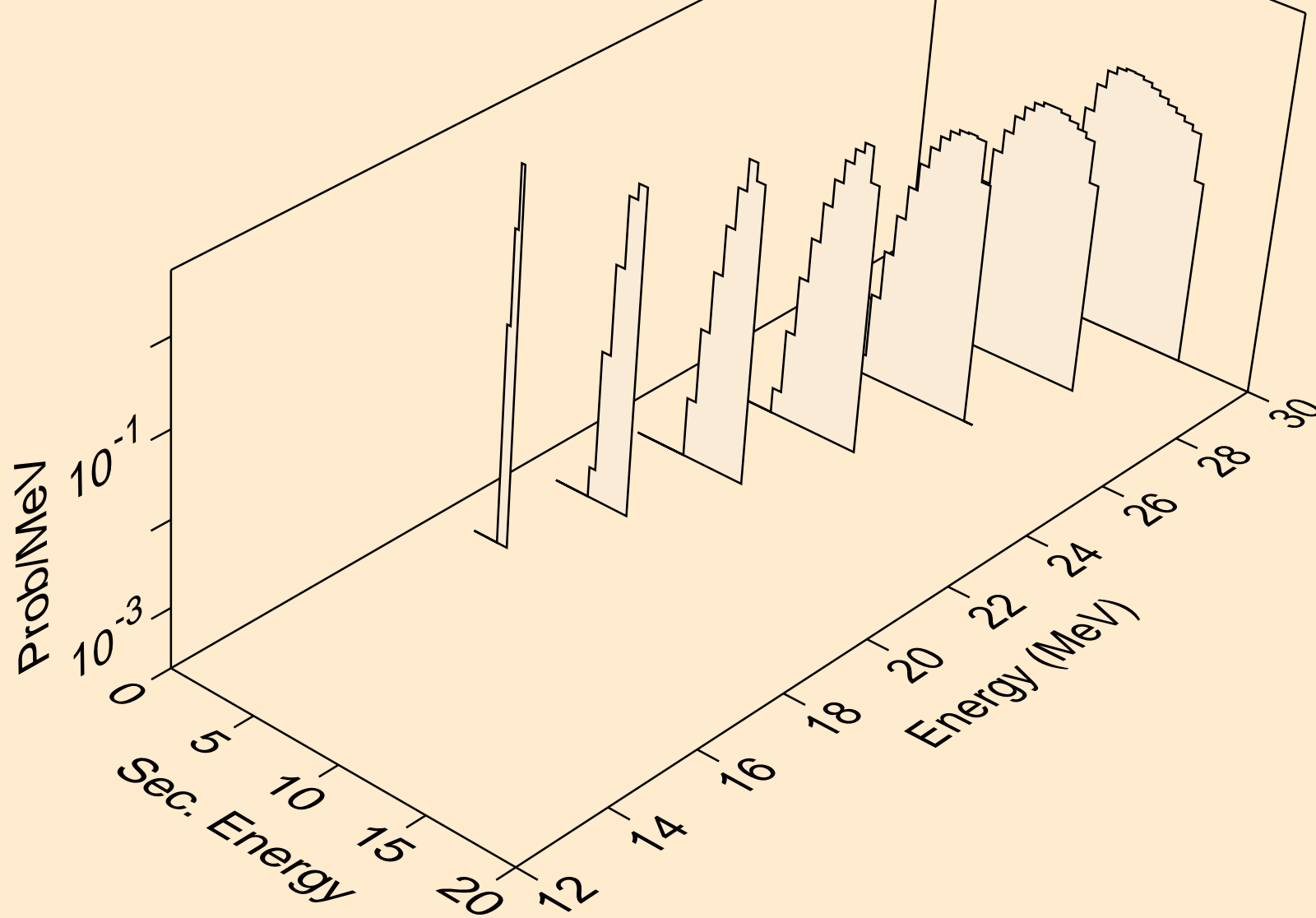

TH239 PHOTON ACER TENDL-2024 LIBRARY; T=0.K  
tritons from (g,t)

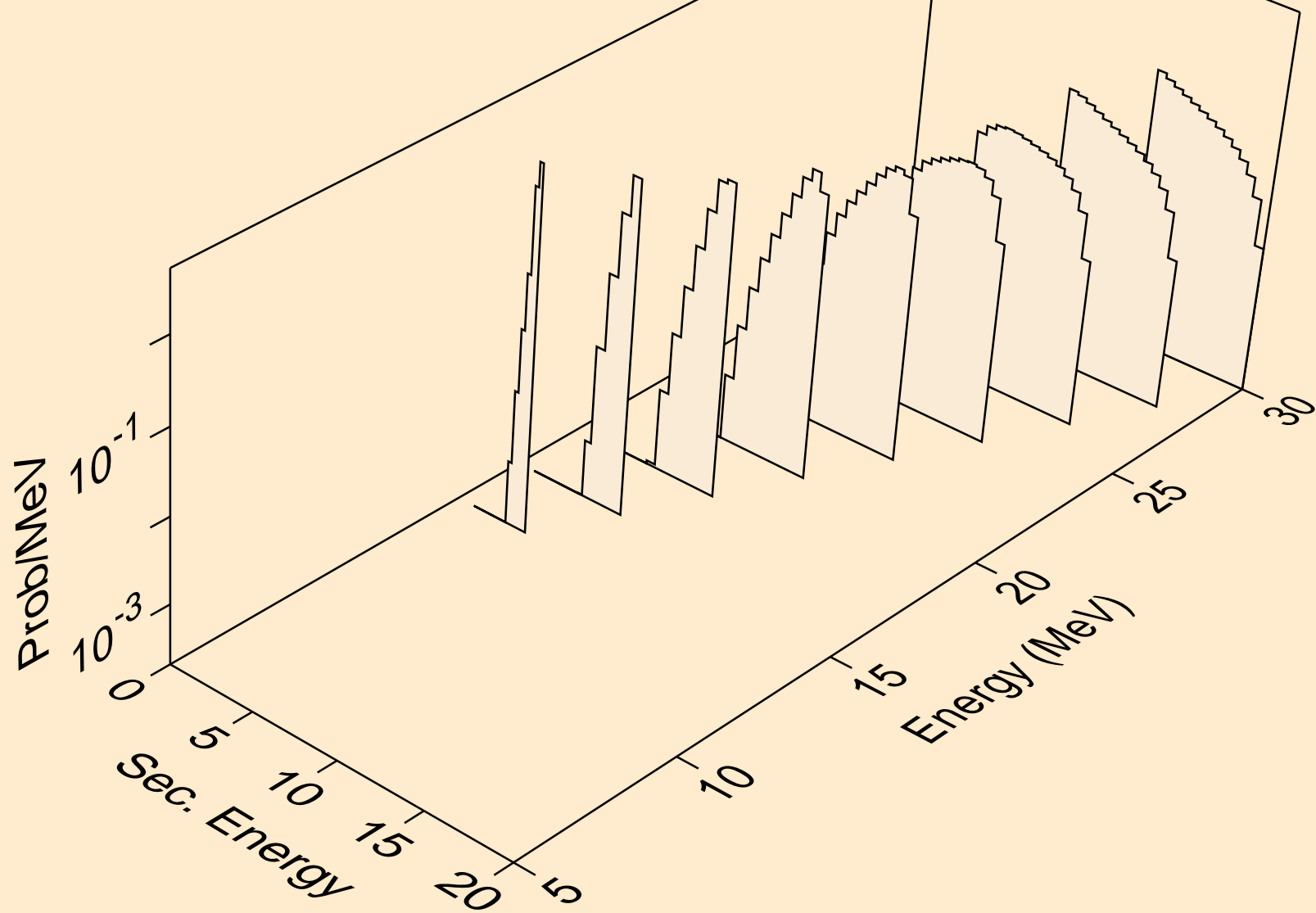

TH239 PHOTON ACER TENDL-2024 LIBRARY; T=0.K  
he3s from (g,x)

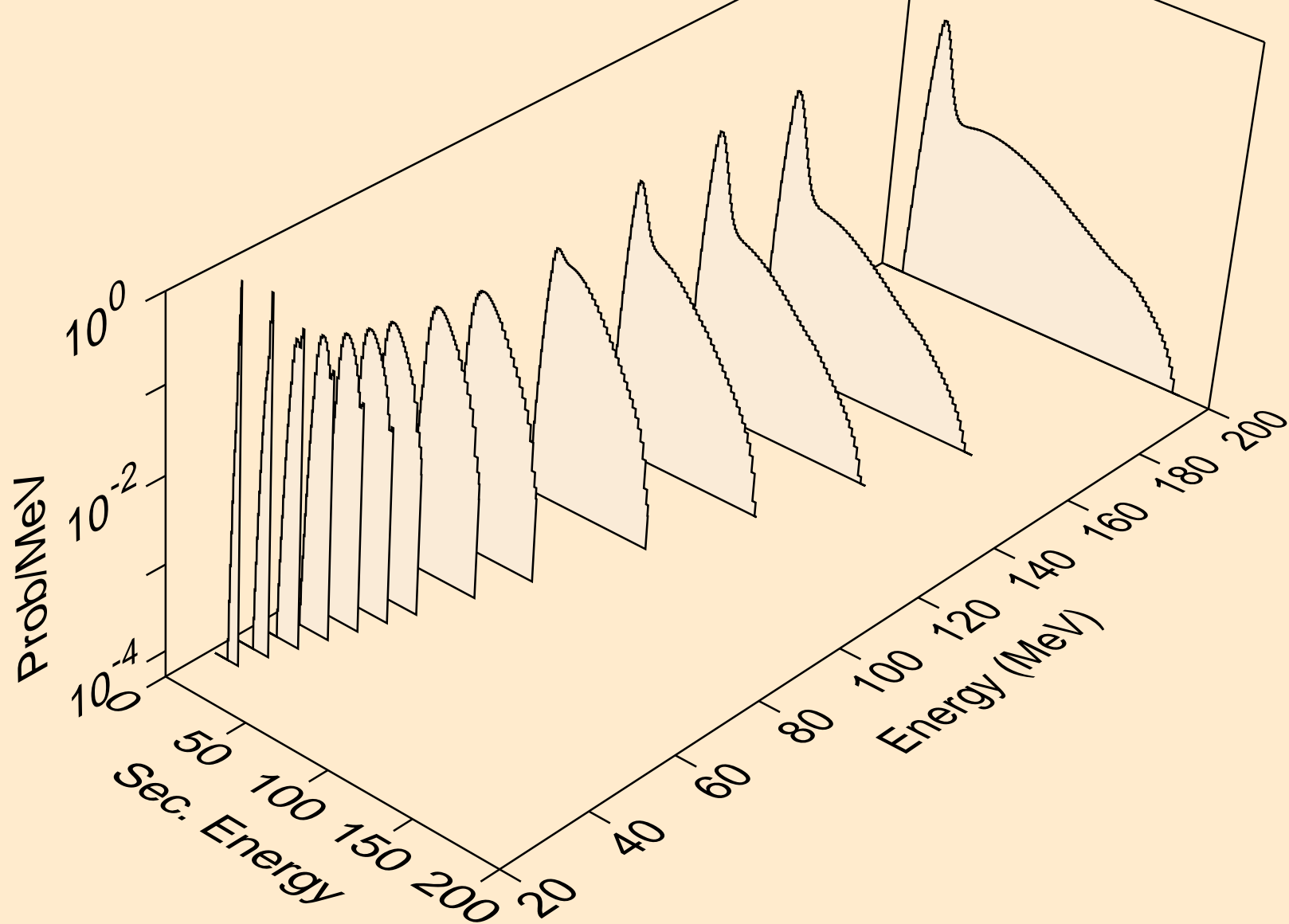

TH239 PHOTON ACER TENDL-2024 LIBRARY; T=0.K  
alphas from (g,x)

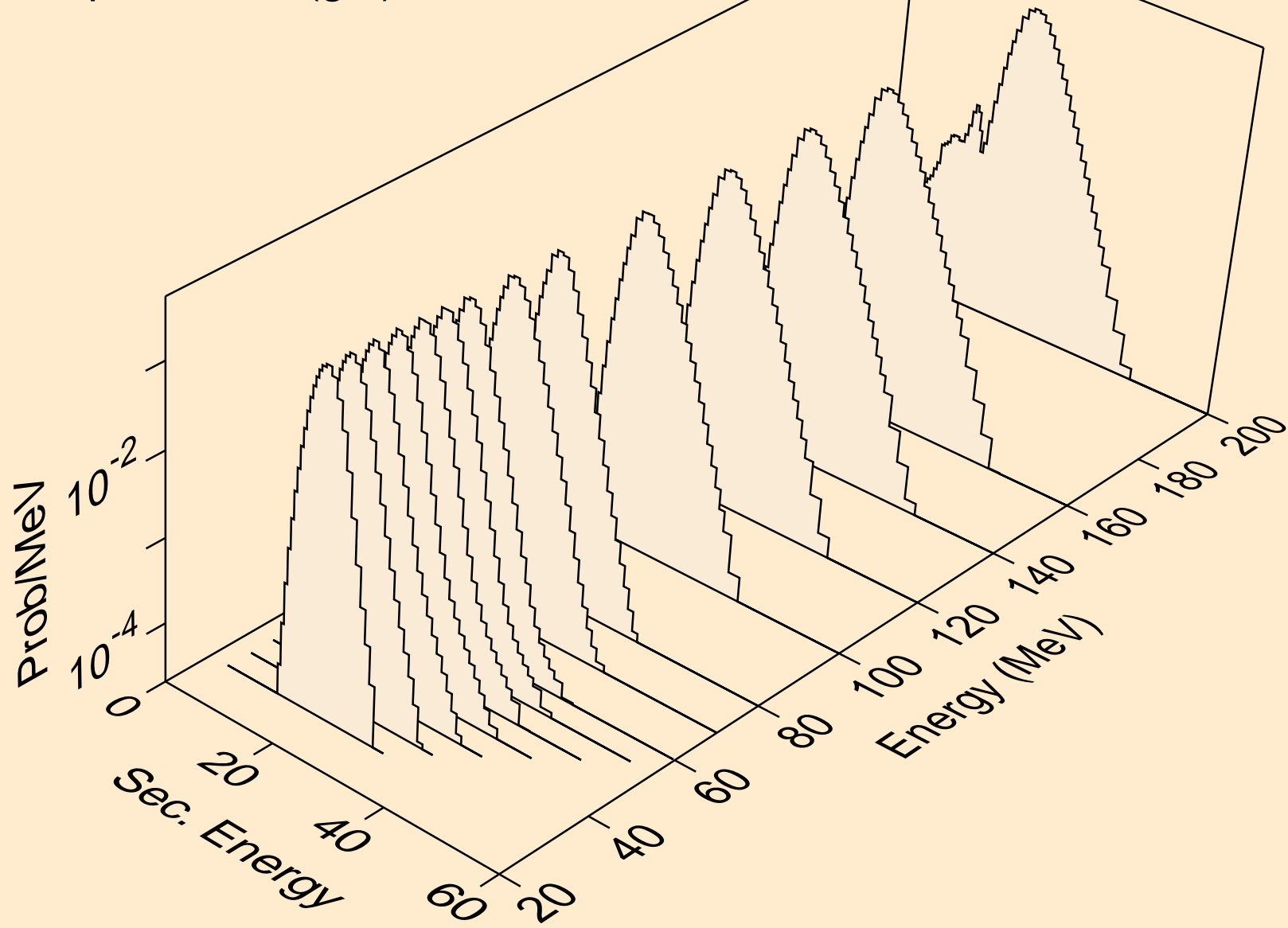

TH239 PHOTON ACER TENDL-2024 LIBRARY; T=0.K  
alphas from (g,n\*)a

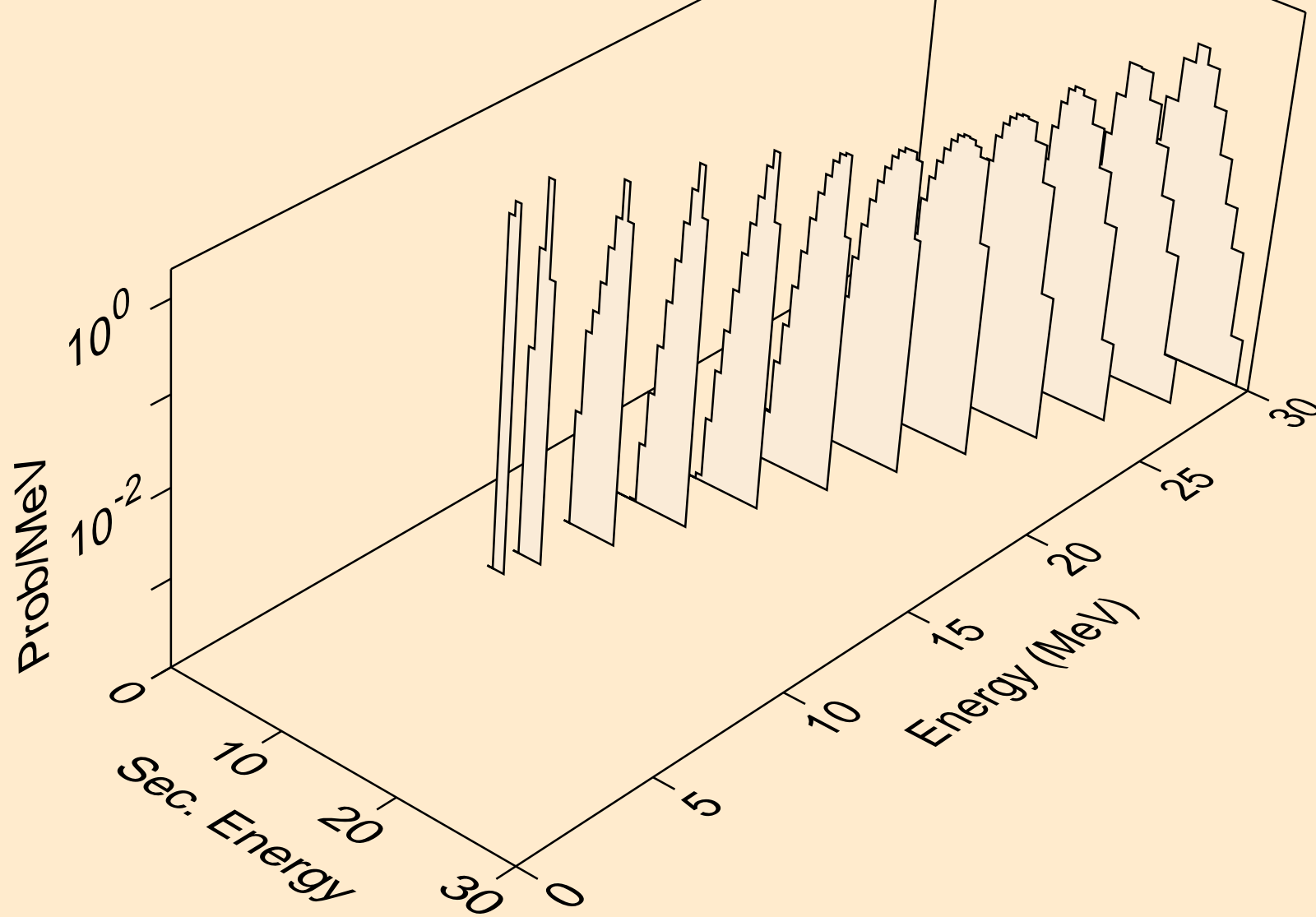

TH239 PHOTON ACER TENDL-2024 LIBRARY; T=0.K  
alphas from (g,2n)a

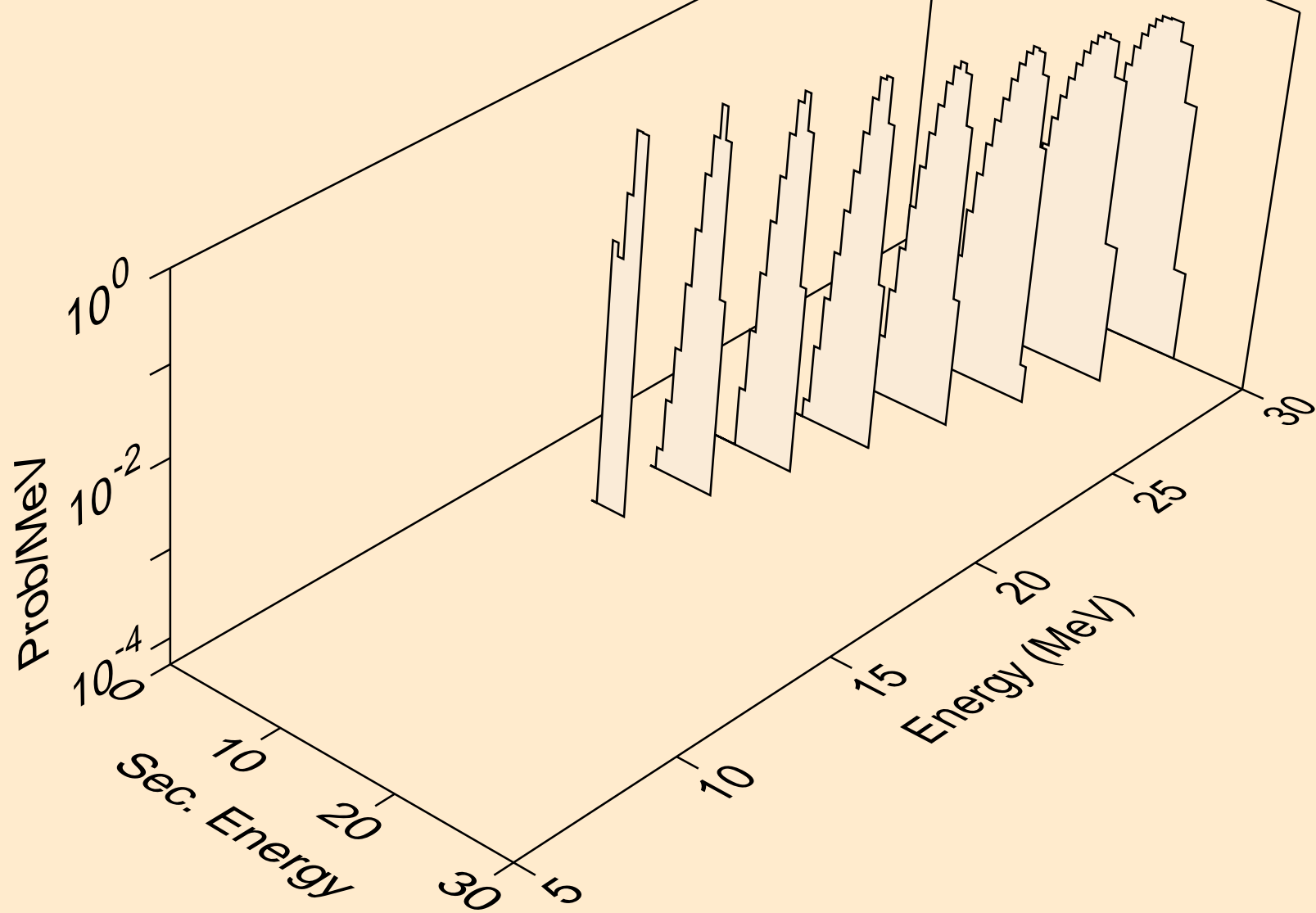

TH239 PHOTON ACER TENDL-2024 LIBRARY; T=0.K  
alphas from (g,3n)a

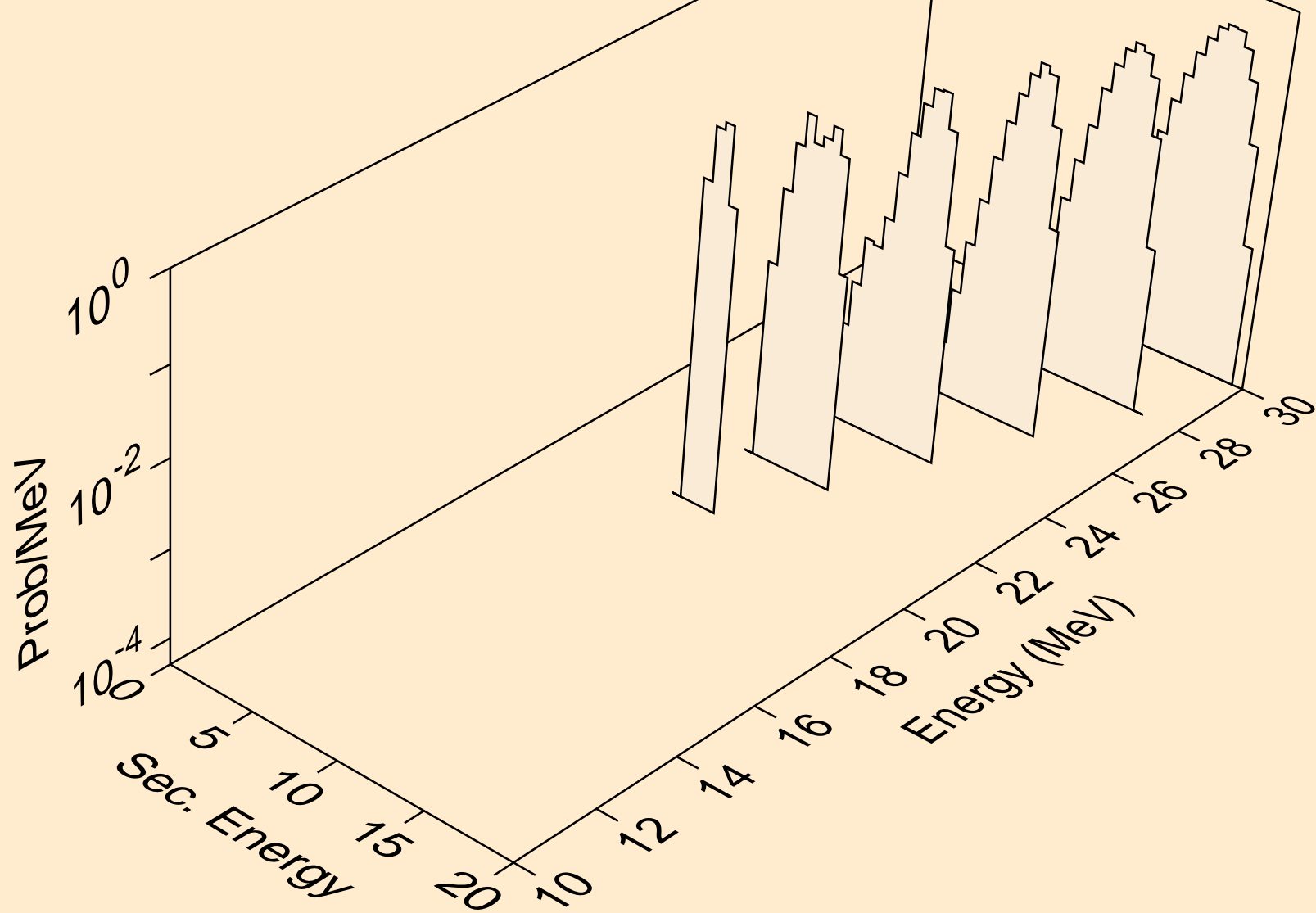

TH239 PHOTON ACER TENDL-2024 LIBRARY; T=0.K  
alphas from (g,a)

