

TM163 PHOTON ACER TENDL-2024 LIBRARY; T=0.K  
Principal cross sections

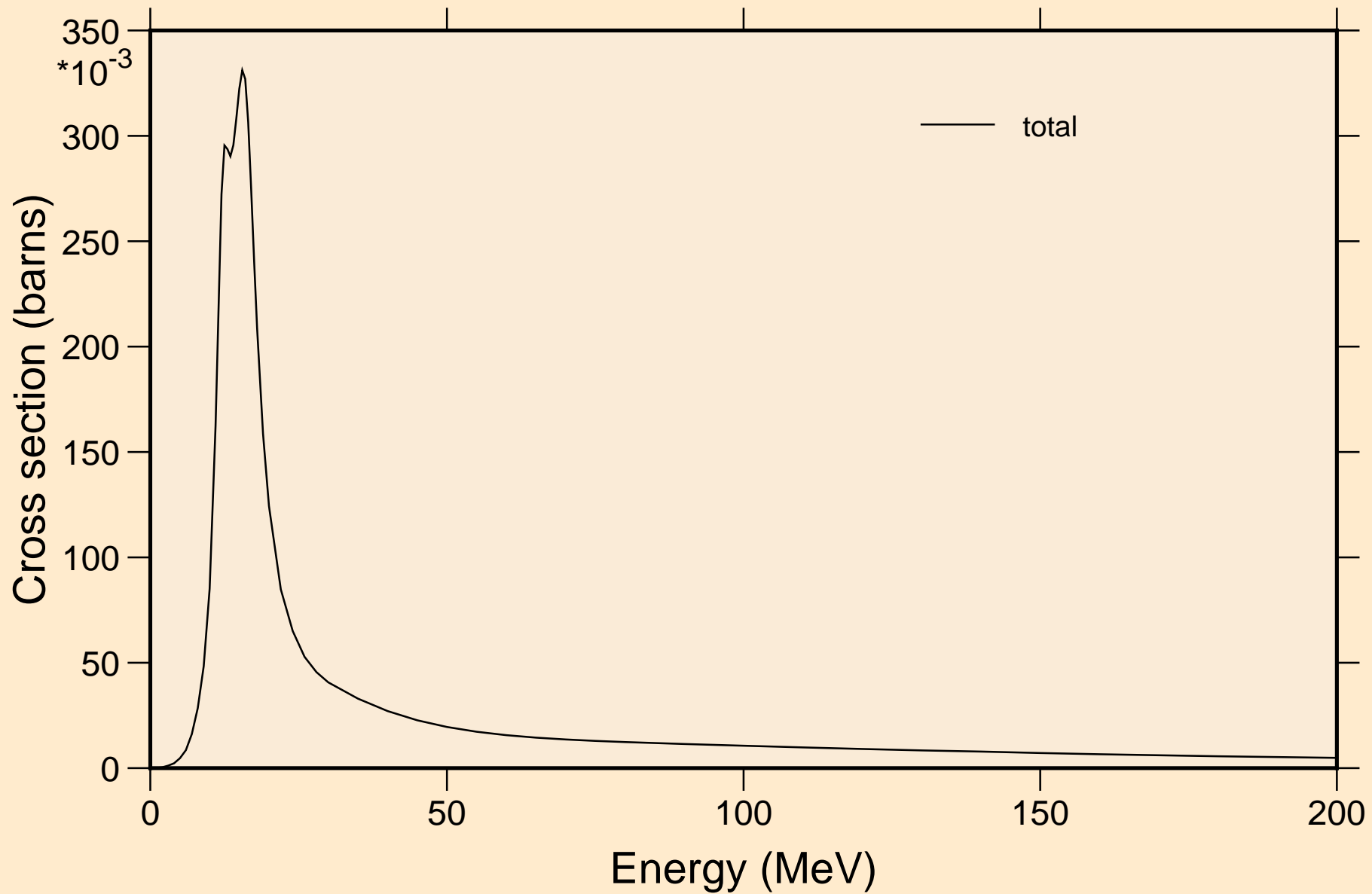

# TM163 PHOTON ACER TENDL-2024 LIBRARY; T=0.K

## Partial cross sections

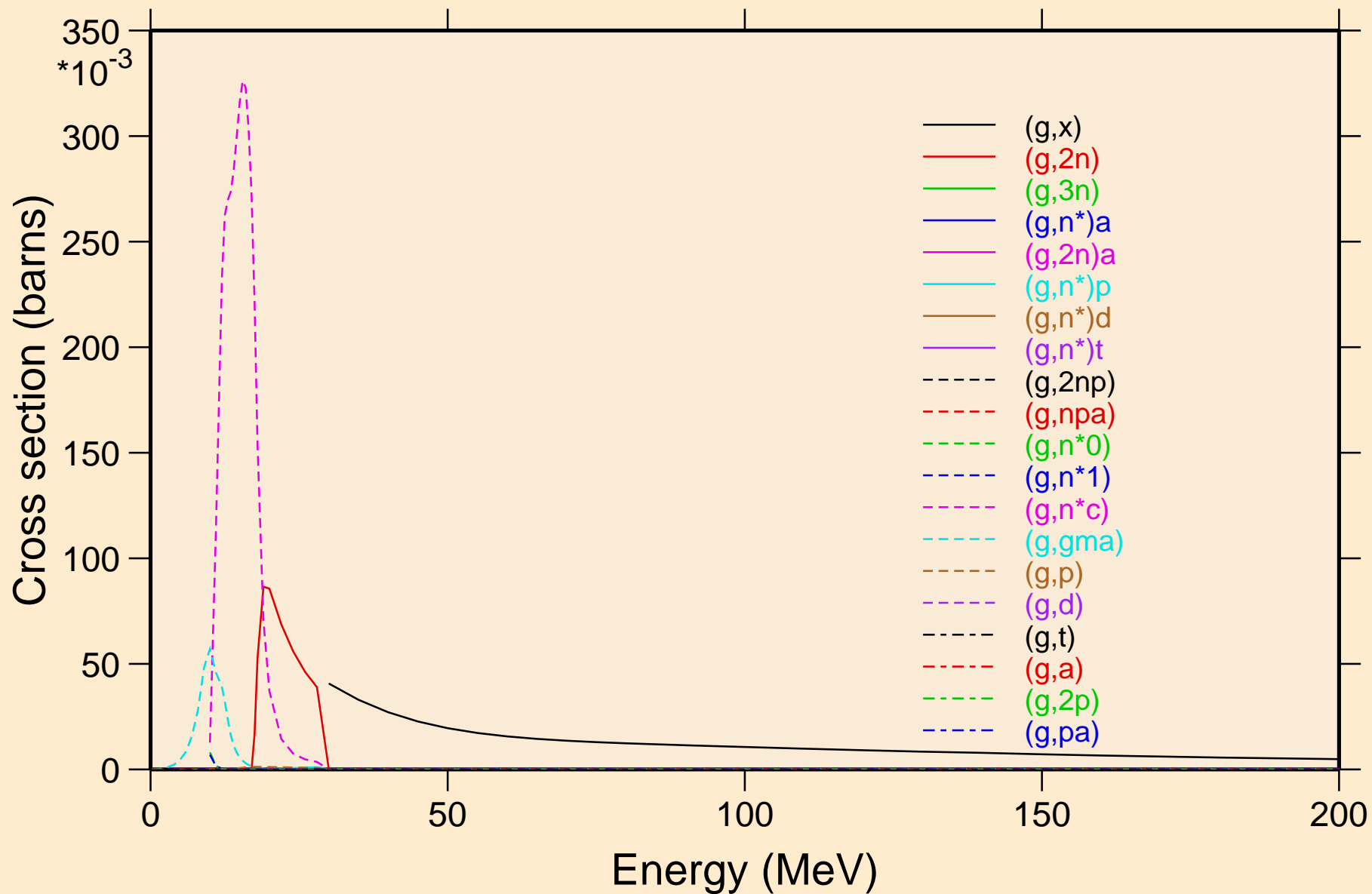

# TM163 PHOTON ACER TENDL-2024 LIBRARY; T=0.K

## Heating

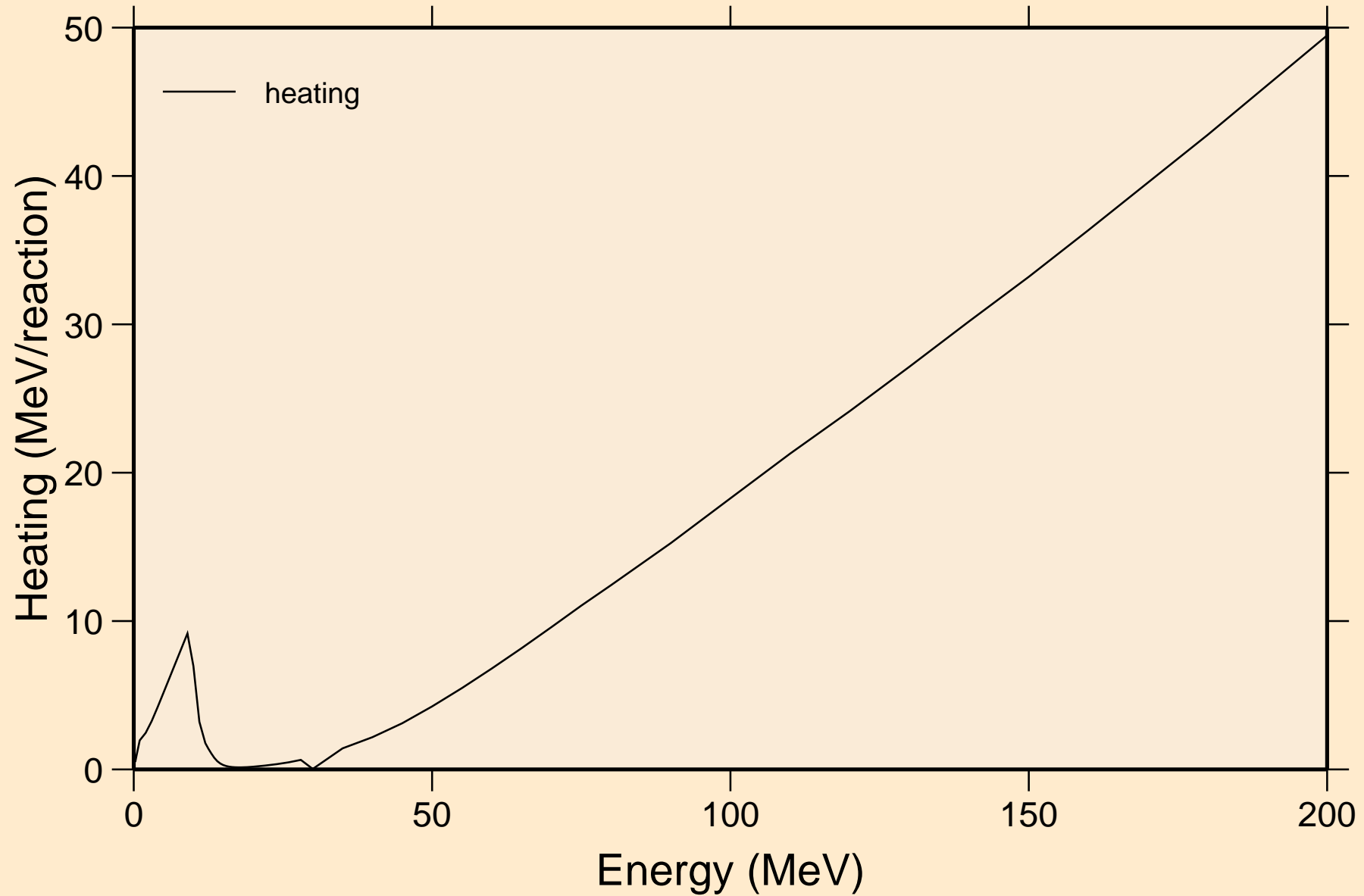

# TM163 PHOTON ACER TENDL-2024 LIBRARY; T=0.K

## Particle heating contributions

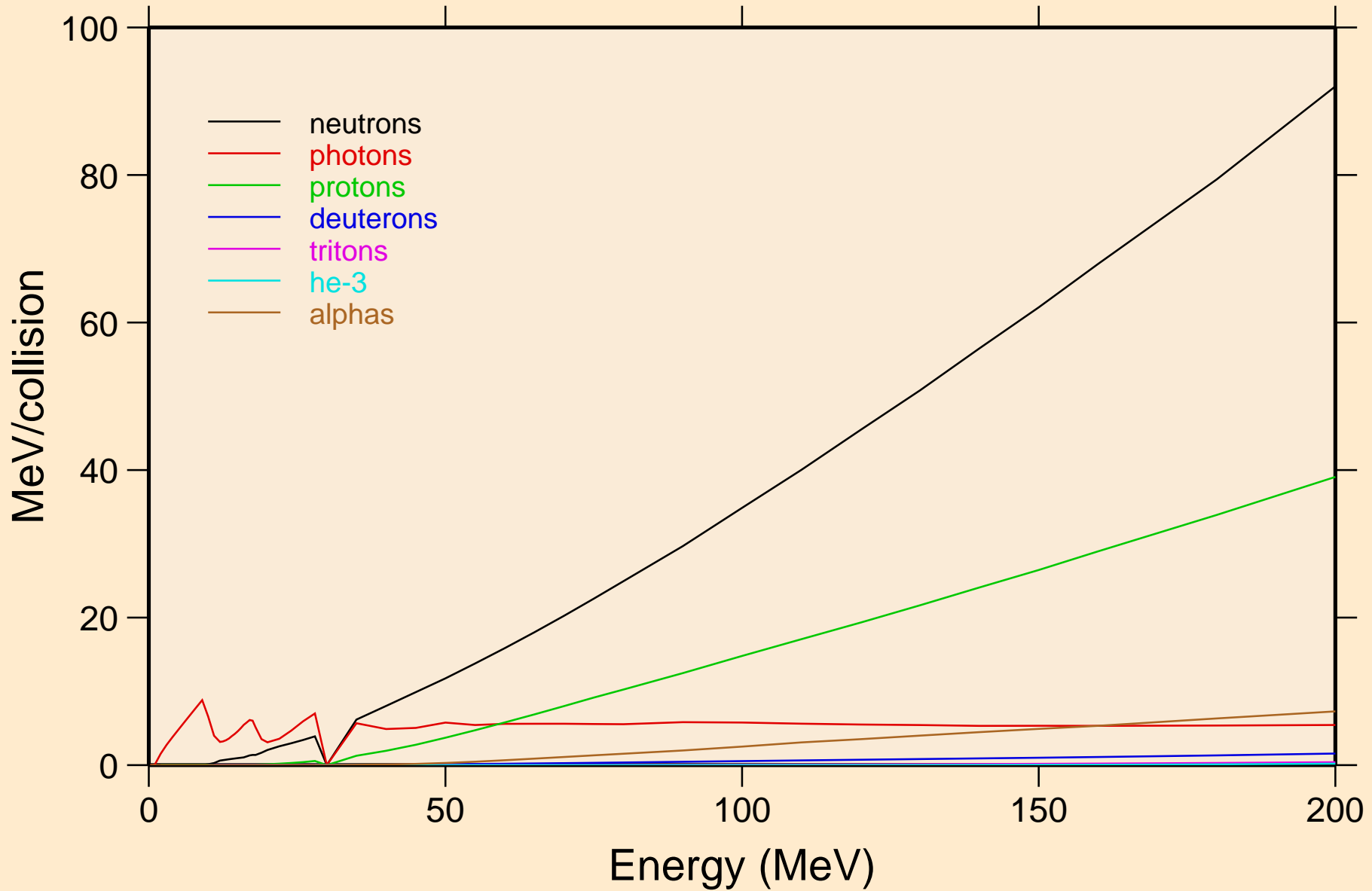

# TM163 PHOTON ACER TENDL-2024 LIBRARY; T=0.K

## Particle production cross sections

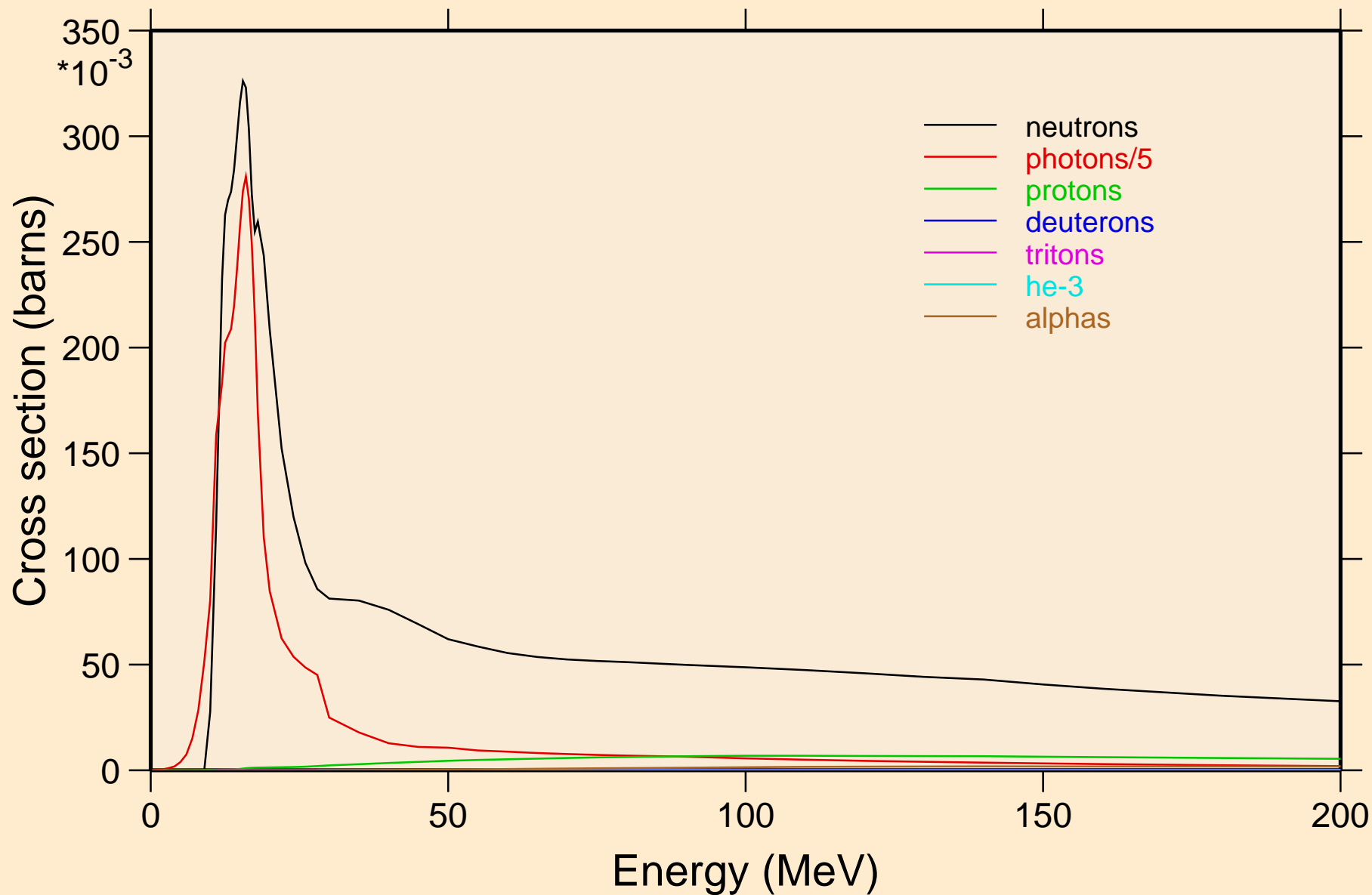

TM163 PHOTON ACER TENDL-2024 LIBRARY; T=0.K  
neutrons from (g,x)

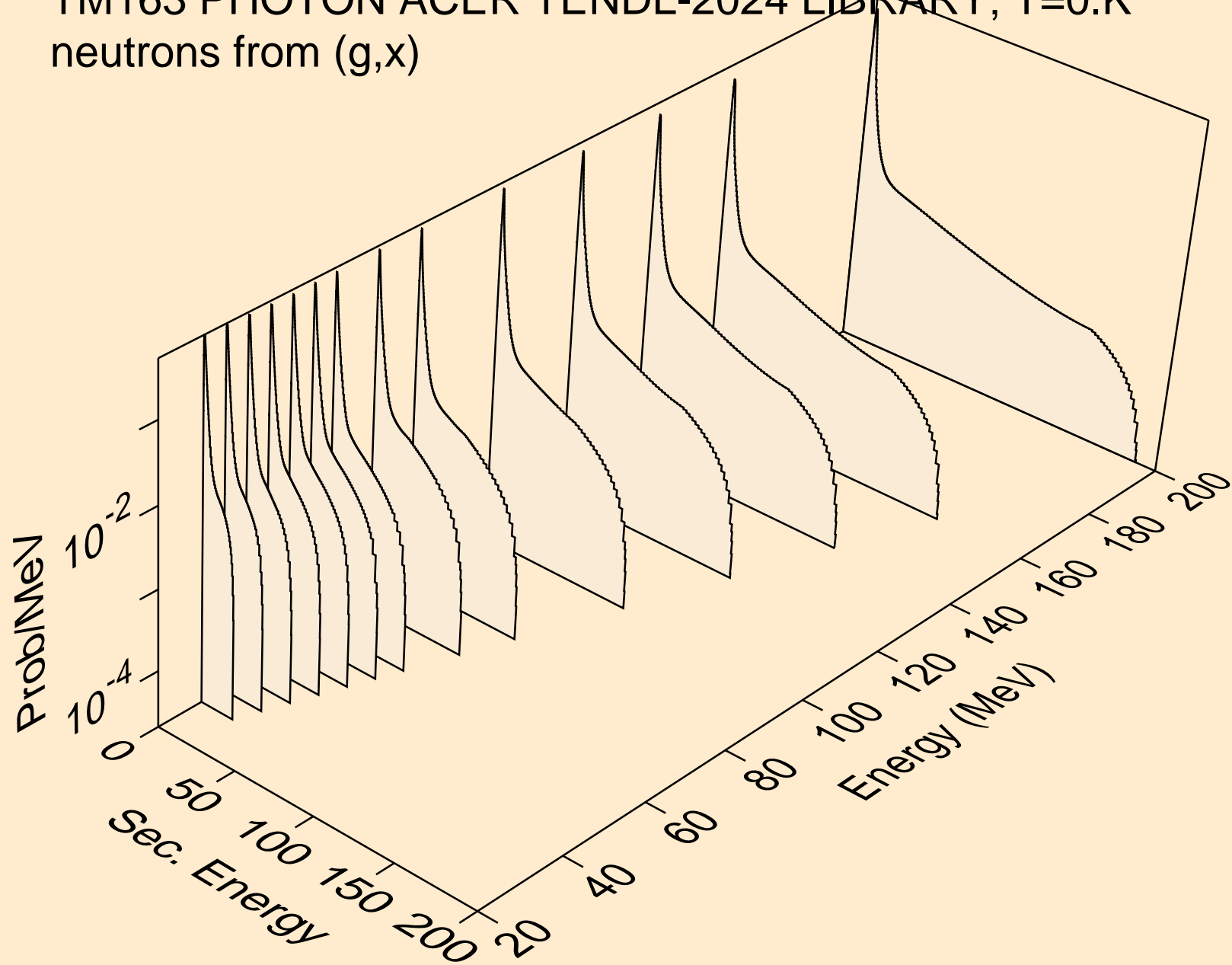

TM163 PHOTON ACER TENDL-2024 LIBRARY; T=0.K  
neutrons from (g,2n)

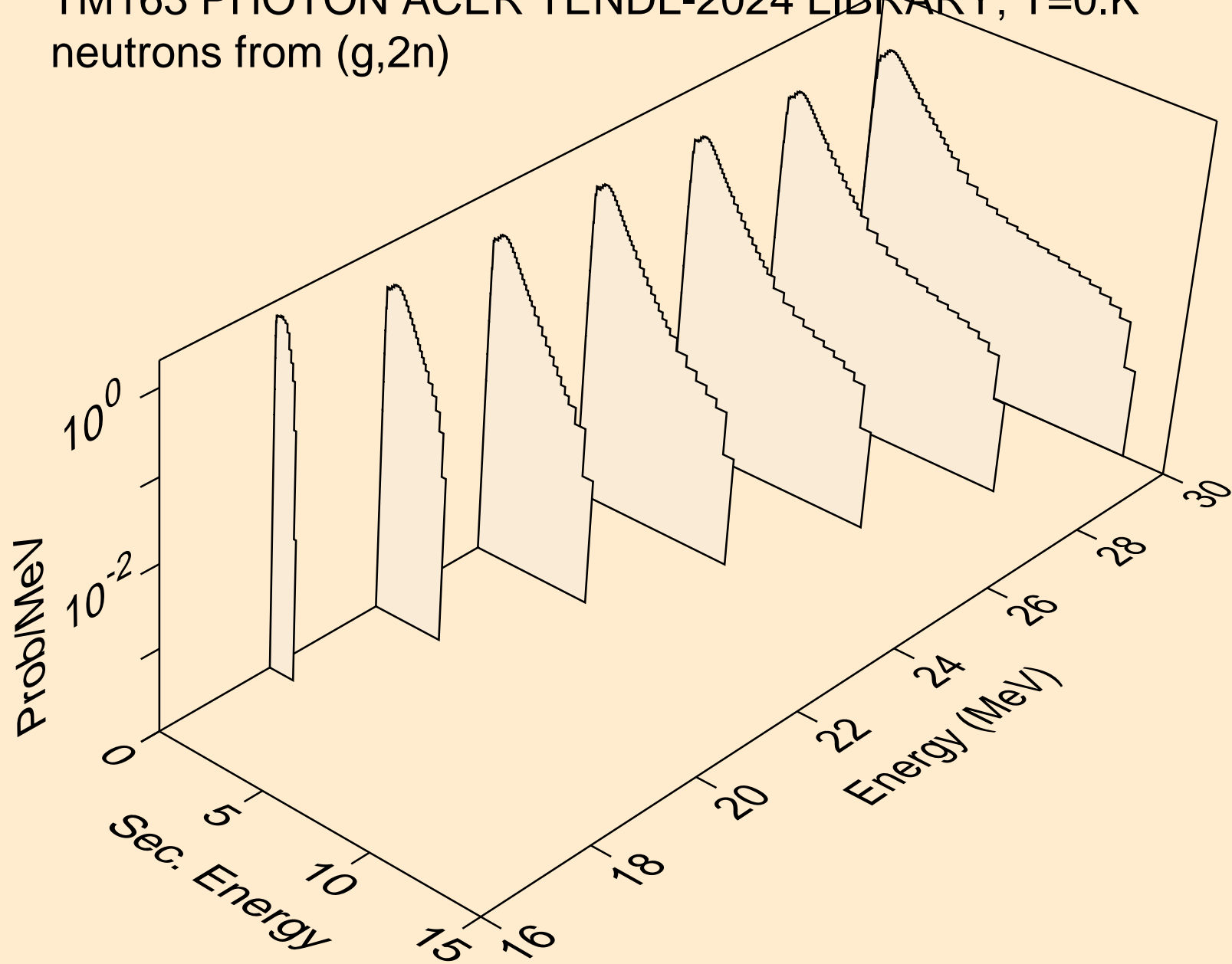

TM163 PHOTON ACER TENDL-2024 LIBRARY; T=0.K  
neutrons from (g,3n)

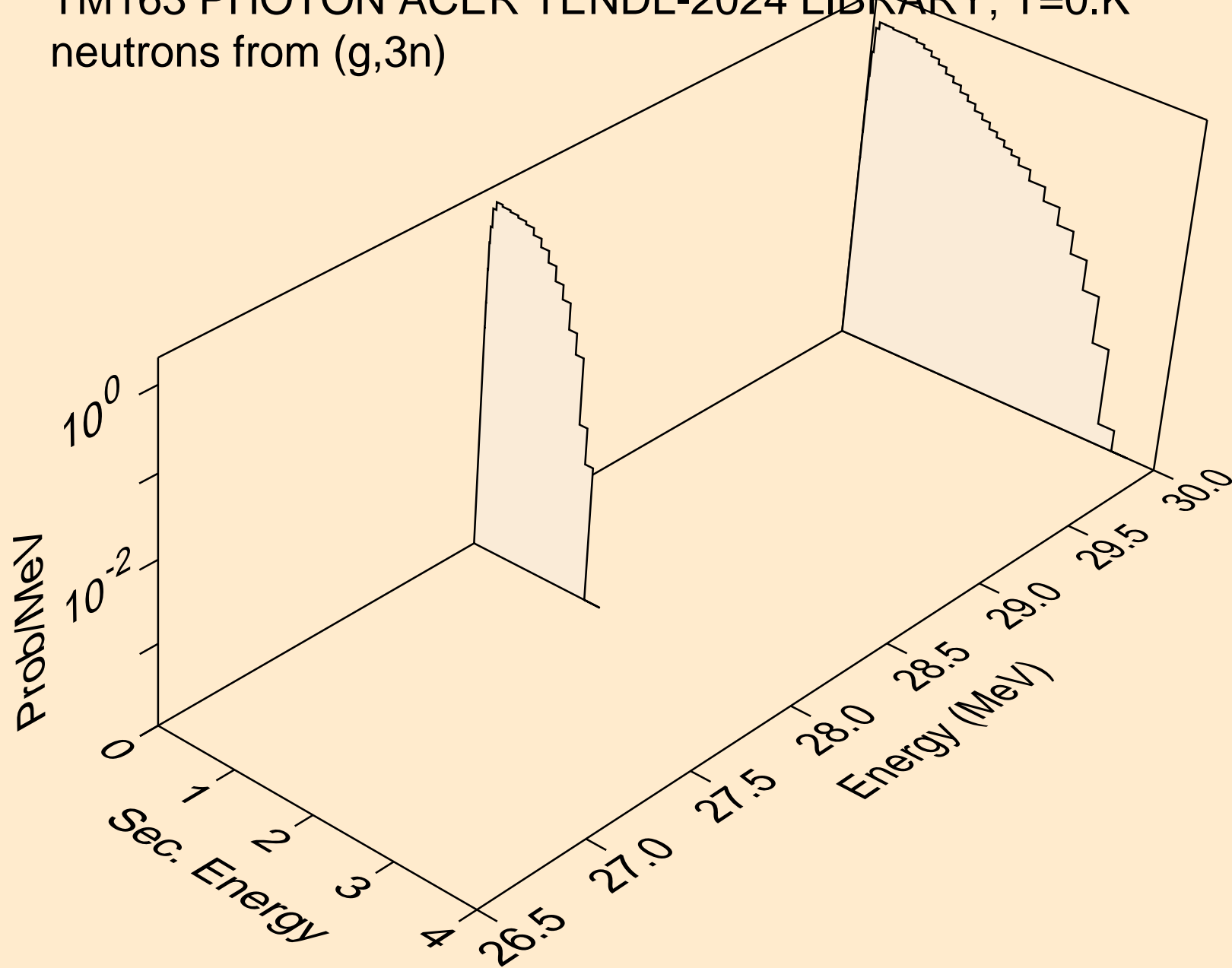

TM163 PHOTON ACER TENDL-2024 LIBRARY; T=0.K  
neutrons from (g,n\*)a

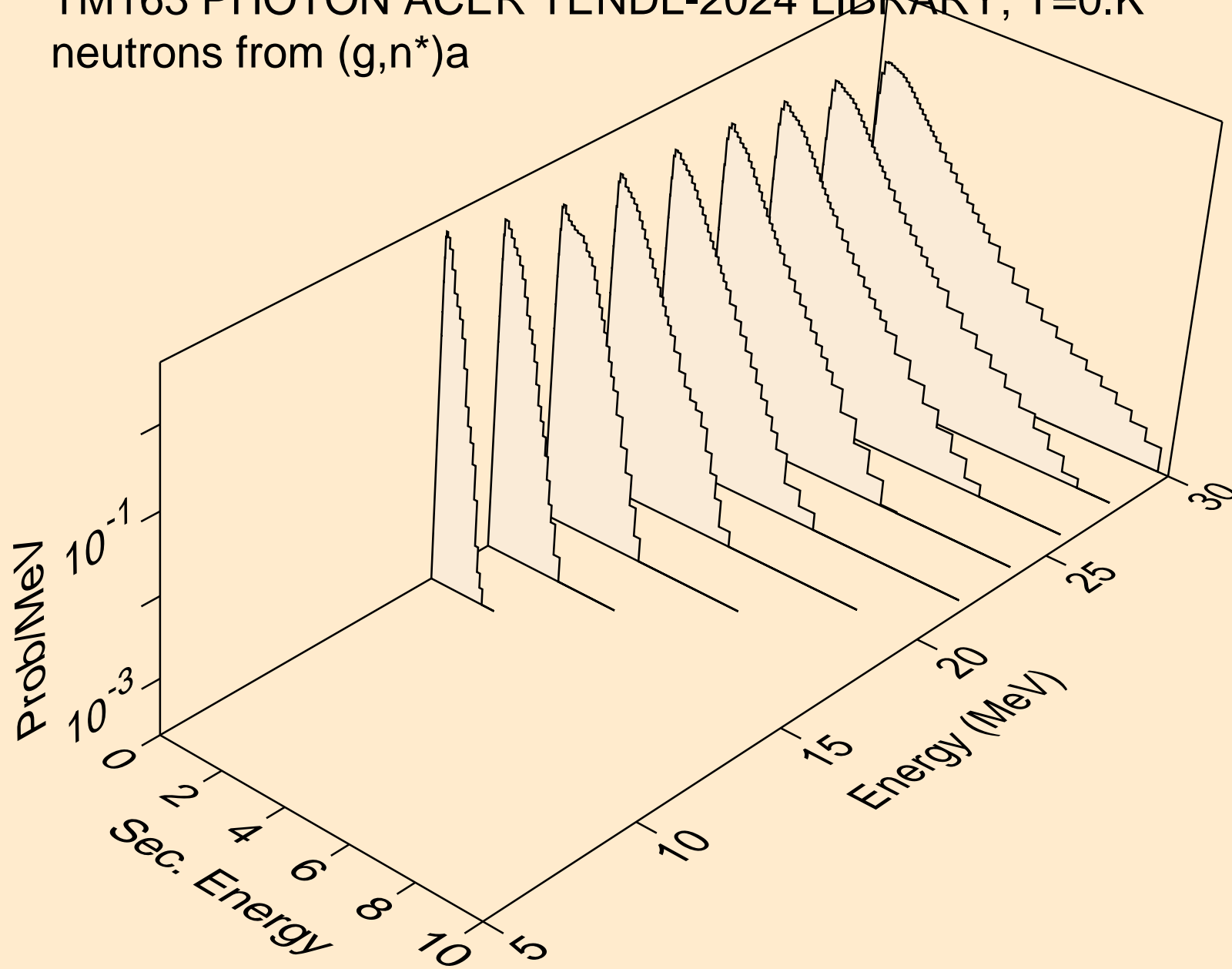

TM163 PHOTON ACER TENDL-2024 LIBRARY; T=0.K  
neutrons from (g,2n)a

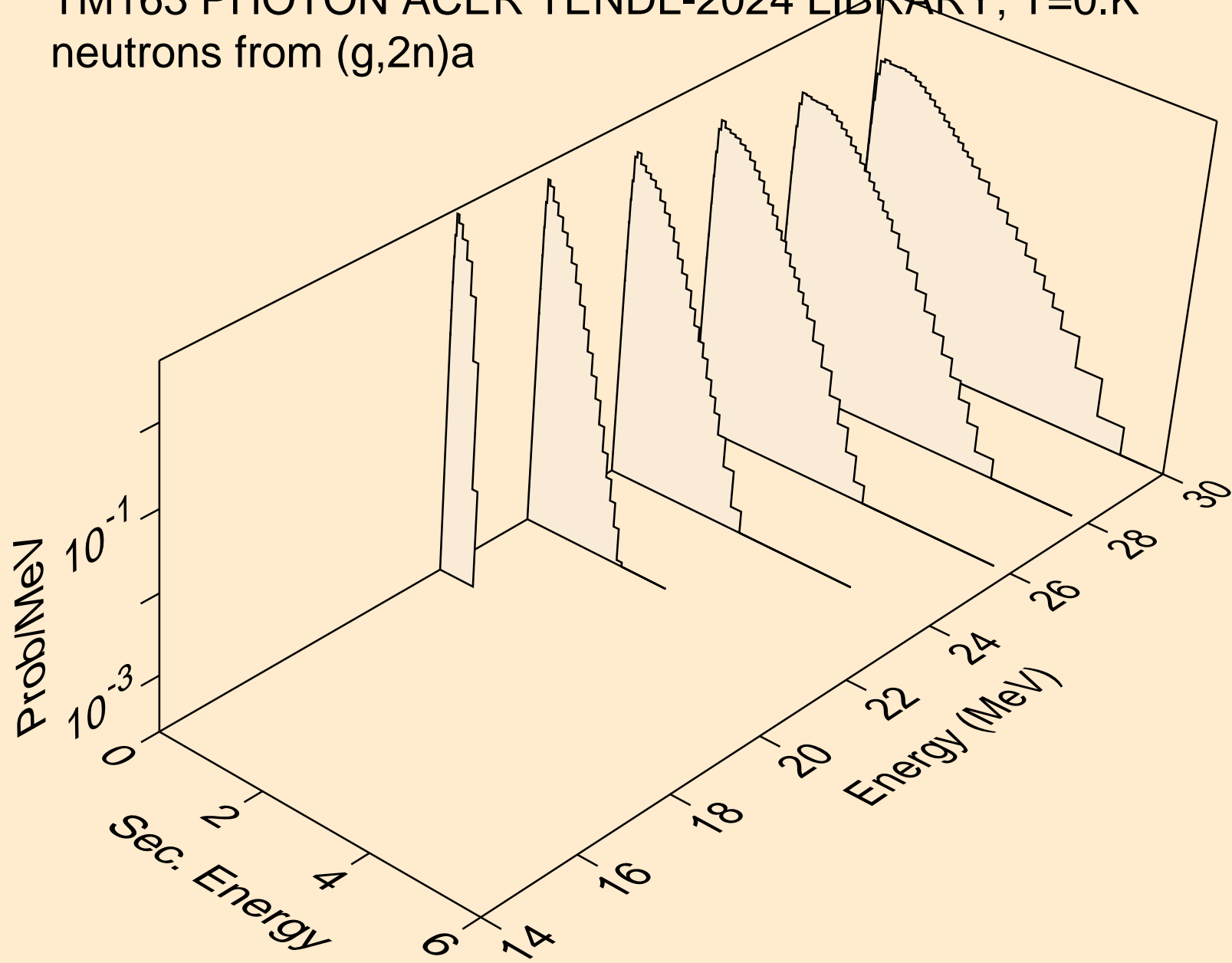

TM163 PHOTON ACER TENDL-2024 LIBRARY; T=0.K  
neutrons from (g,n\*)p

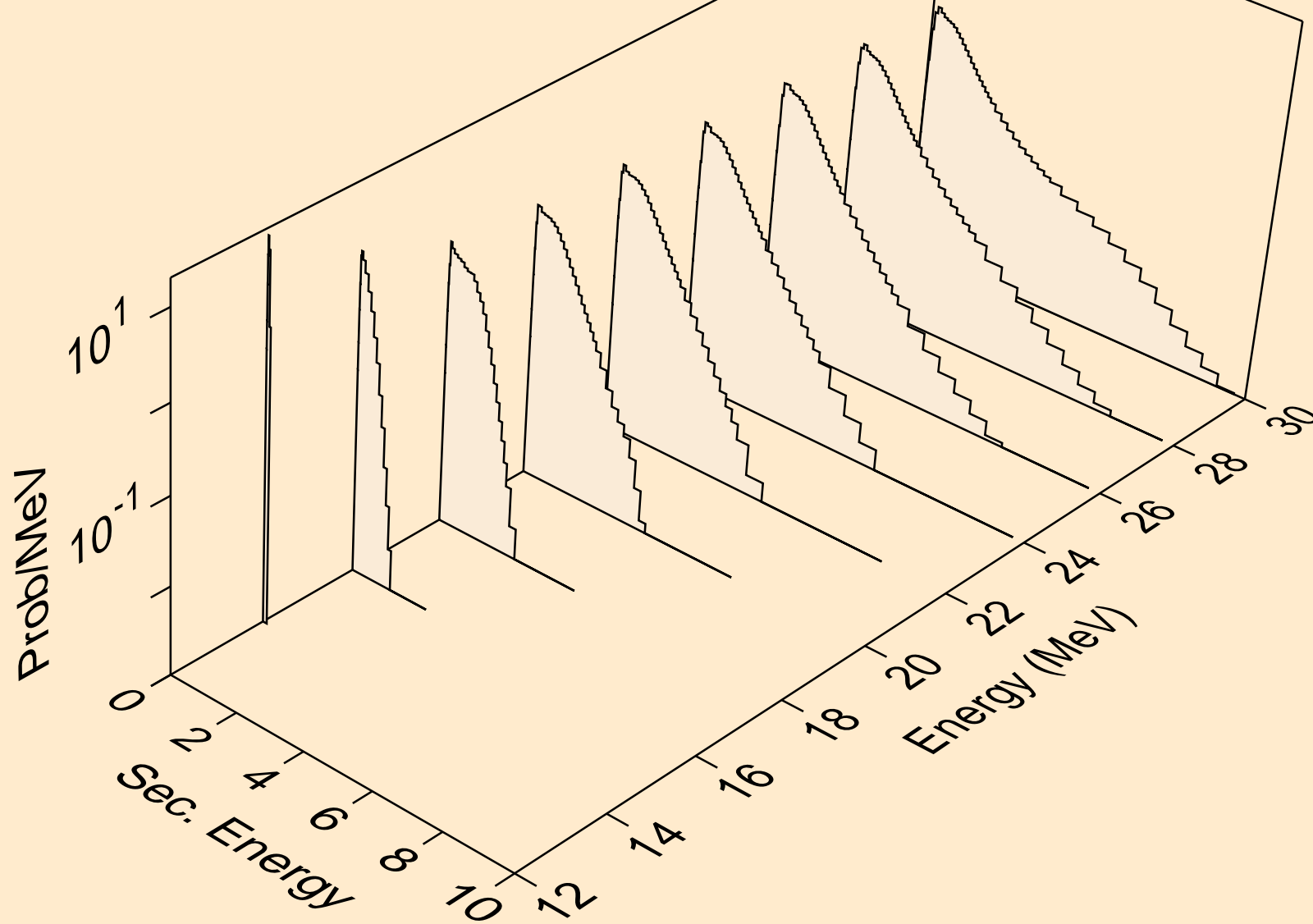

TM163 PHOTON ACER TENDL-2024 LIBRARY; T=0.K  
neutrons from (g,n\*)d

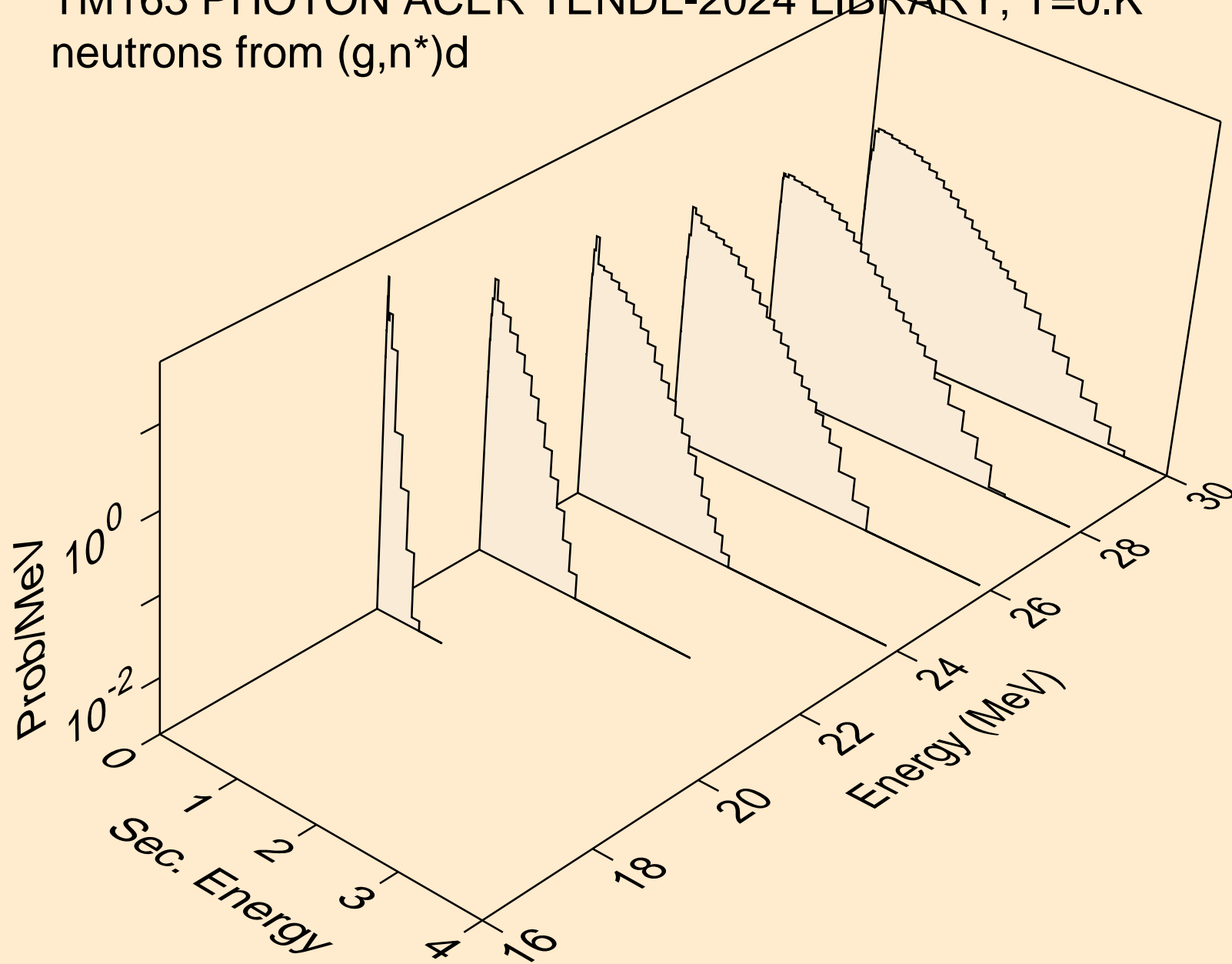

TM163 PHOTON ACER TENDL-2024 LIBRARY; T=0.K  
neutrons from (g,n\*)t

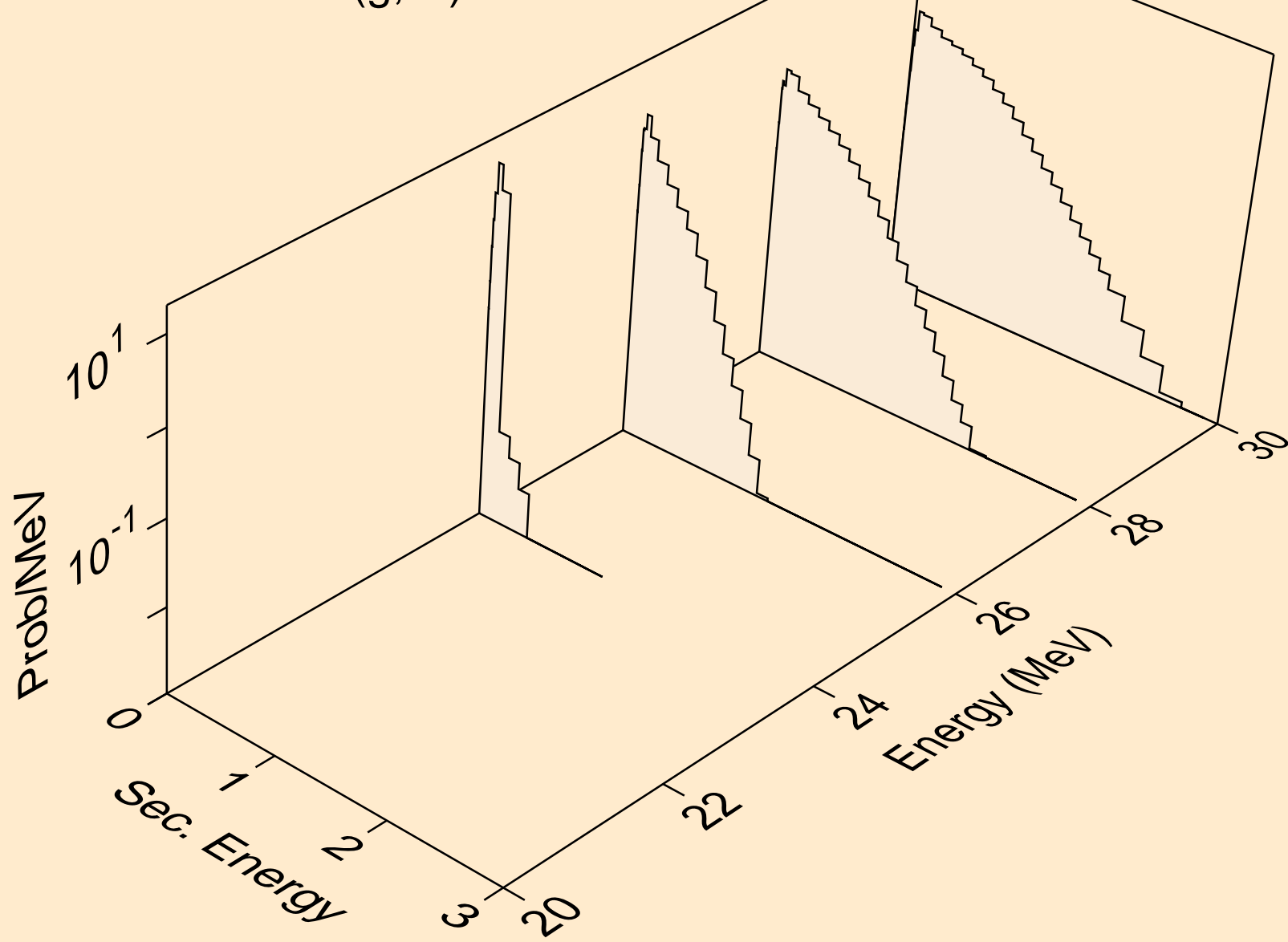

TM163 PHOTON ACER TENDL-2024 LIBRARY; T=0.K  
neutrons from (g,2np)

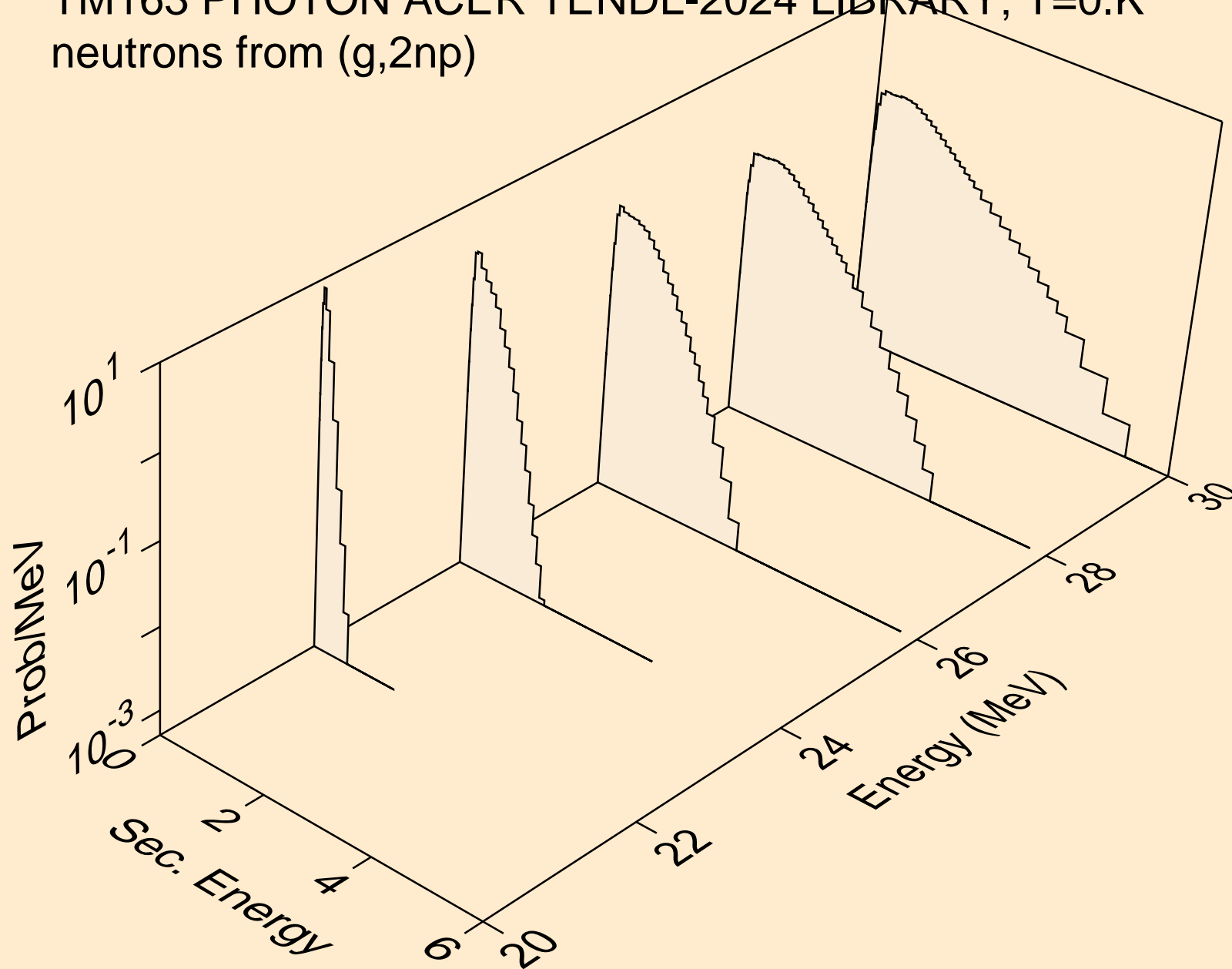

TM163 PHOTON ACER TENDL-2024 LIBRARY; T=0.K  
neutrons from (g,npa)

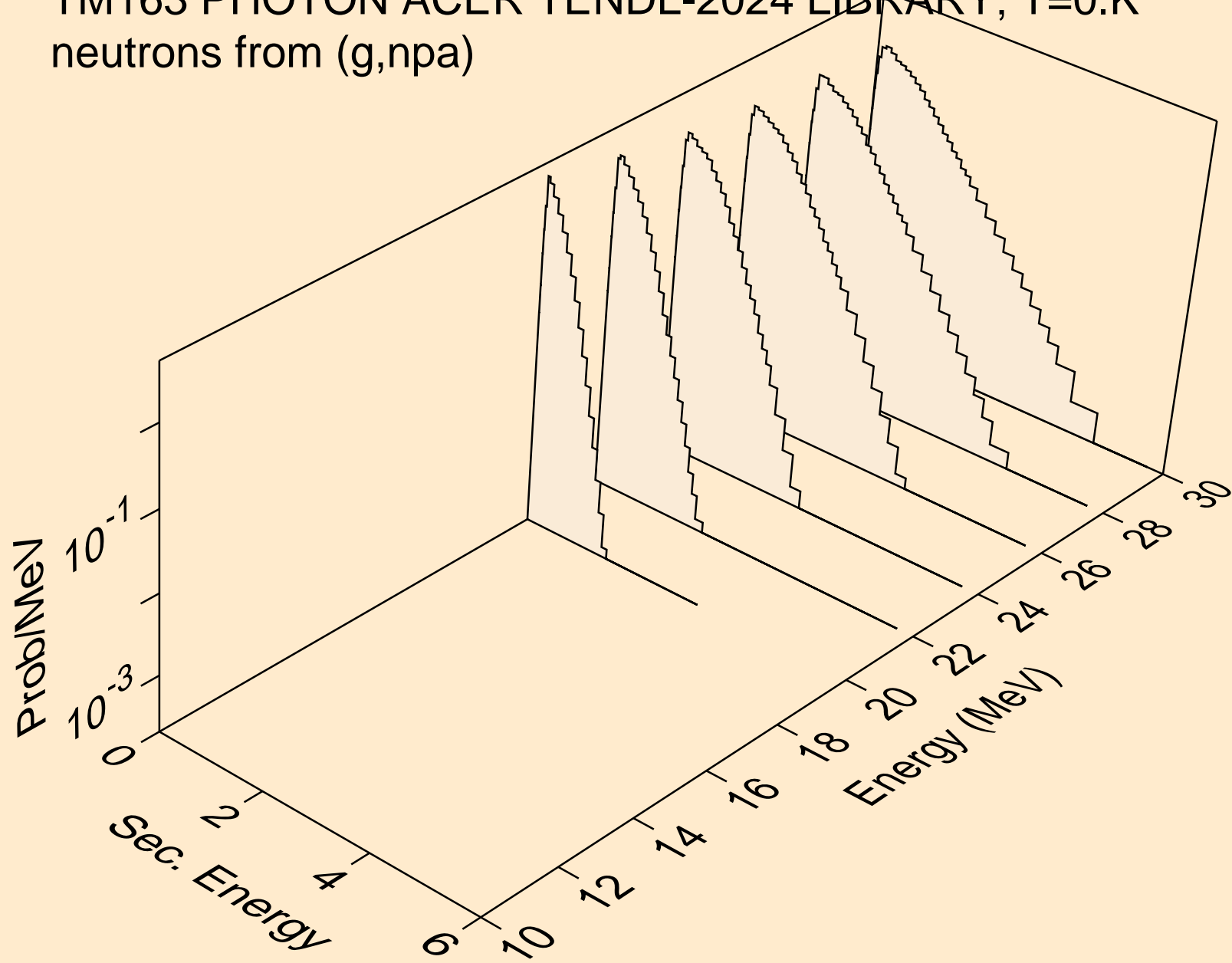

TM163 PHOTON ACER TENDL-2024 LIBRARY; T=0.K  
angular distribution for (g,n\*0) neutron

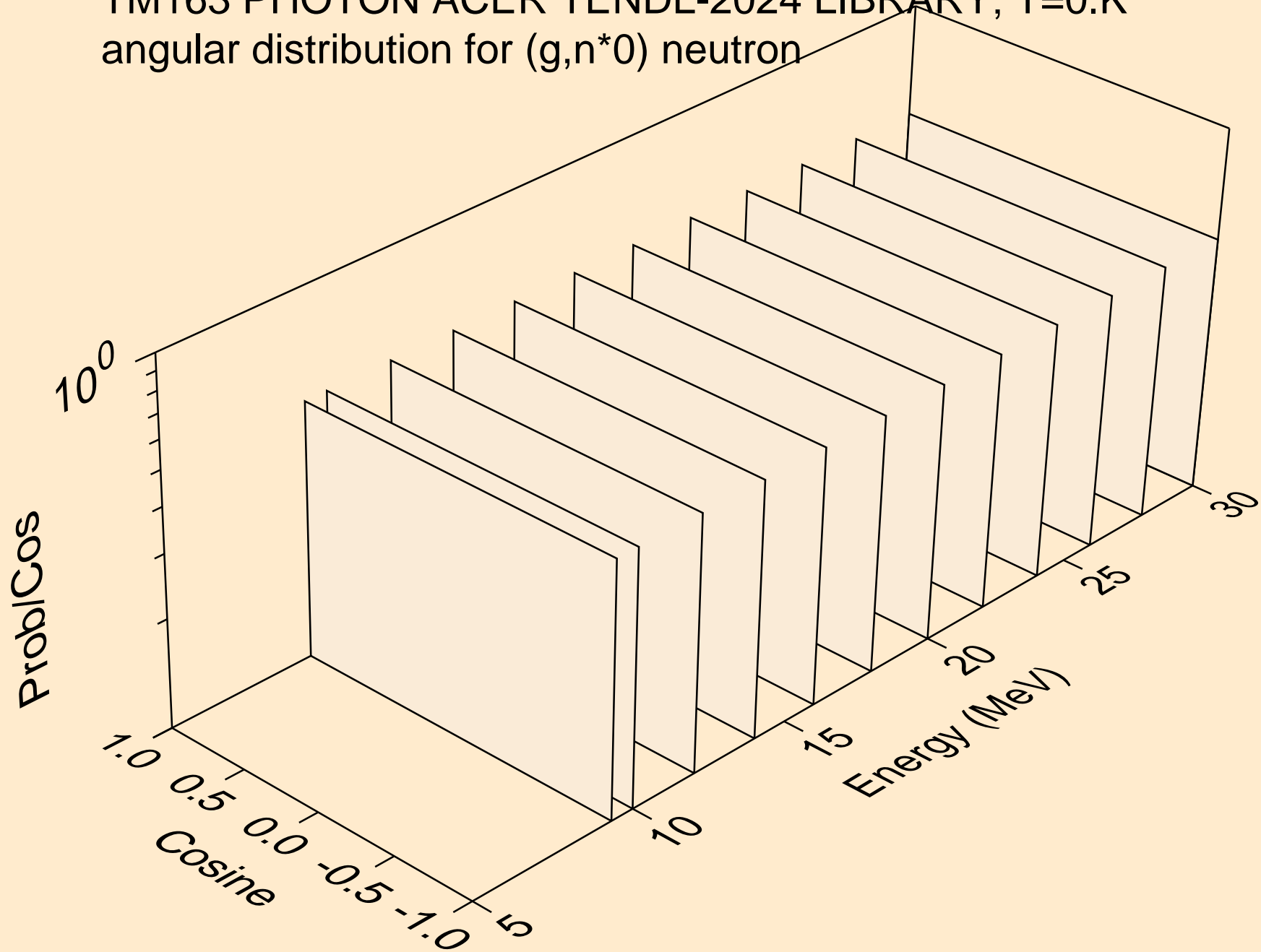

TM163 PHOTON ACER TENDL-2024 LIBRARY; T=0.K  
angular distribution for (g,n\*1) neutron

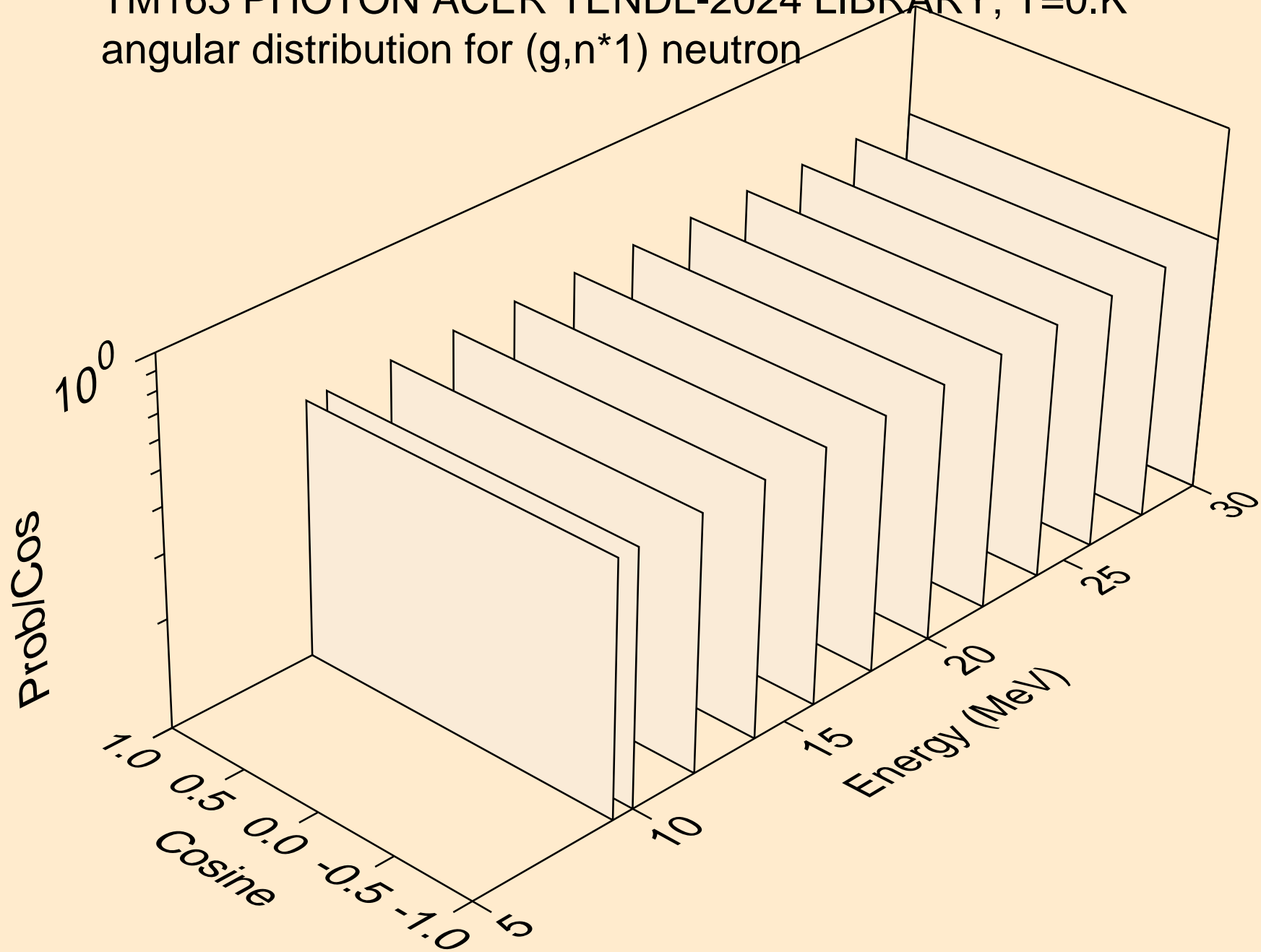

TM163 PHOTON ACER TENDL-2024 LIBRARY; T=0.K  
neutrons from (g,n\*c)

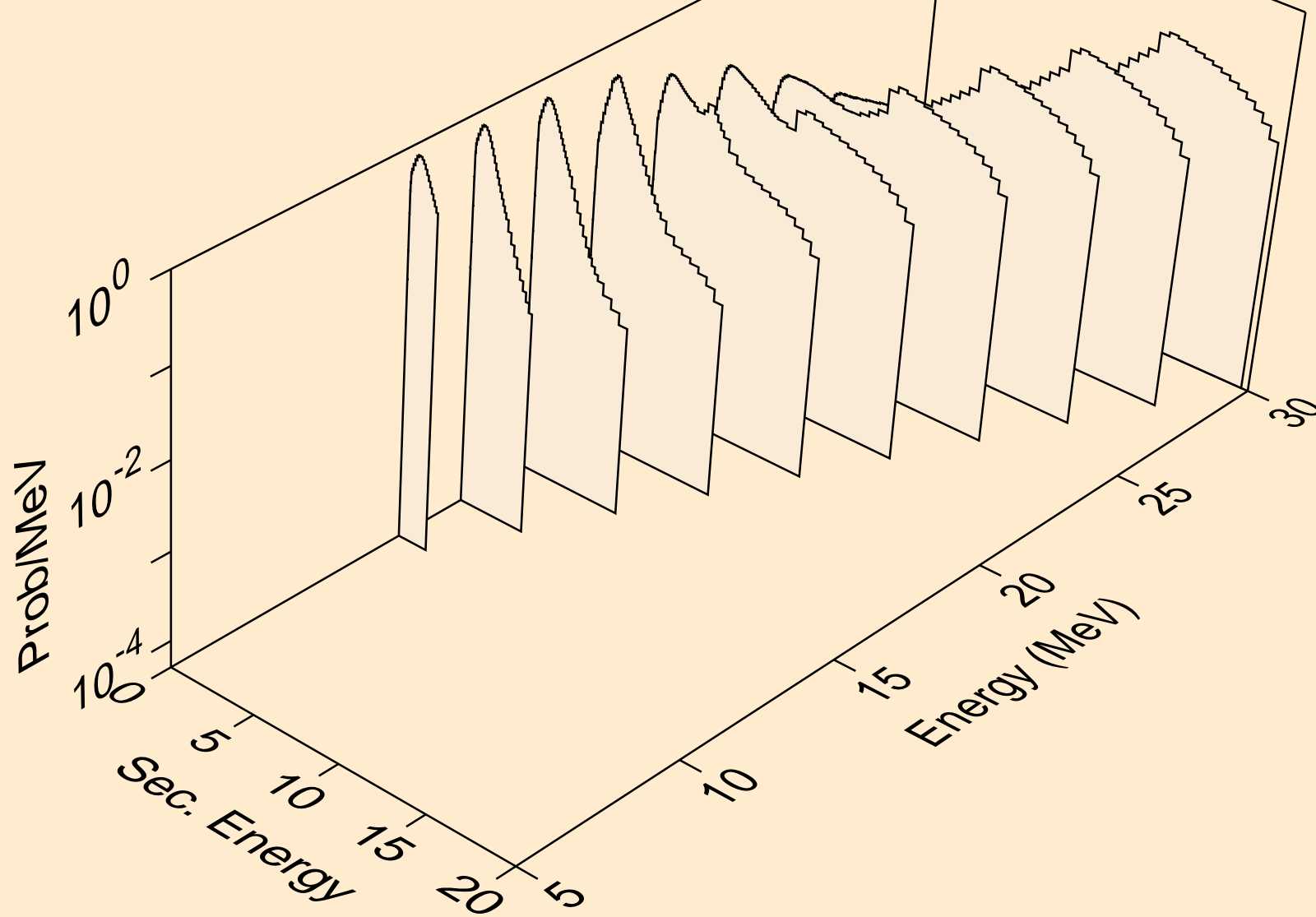

TM163 PHOTON ACER TENDL-2024 LIBRARY; T=0.K  
photons from (g,x)

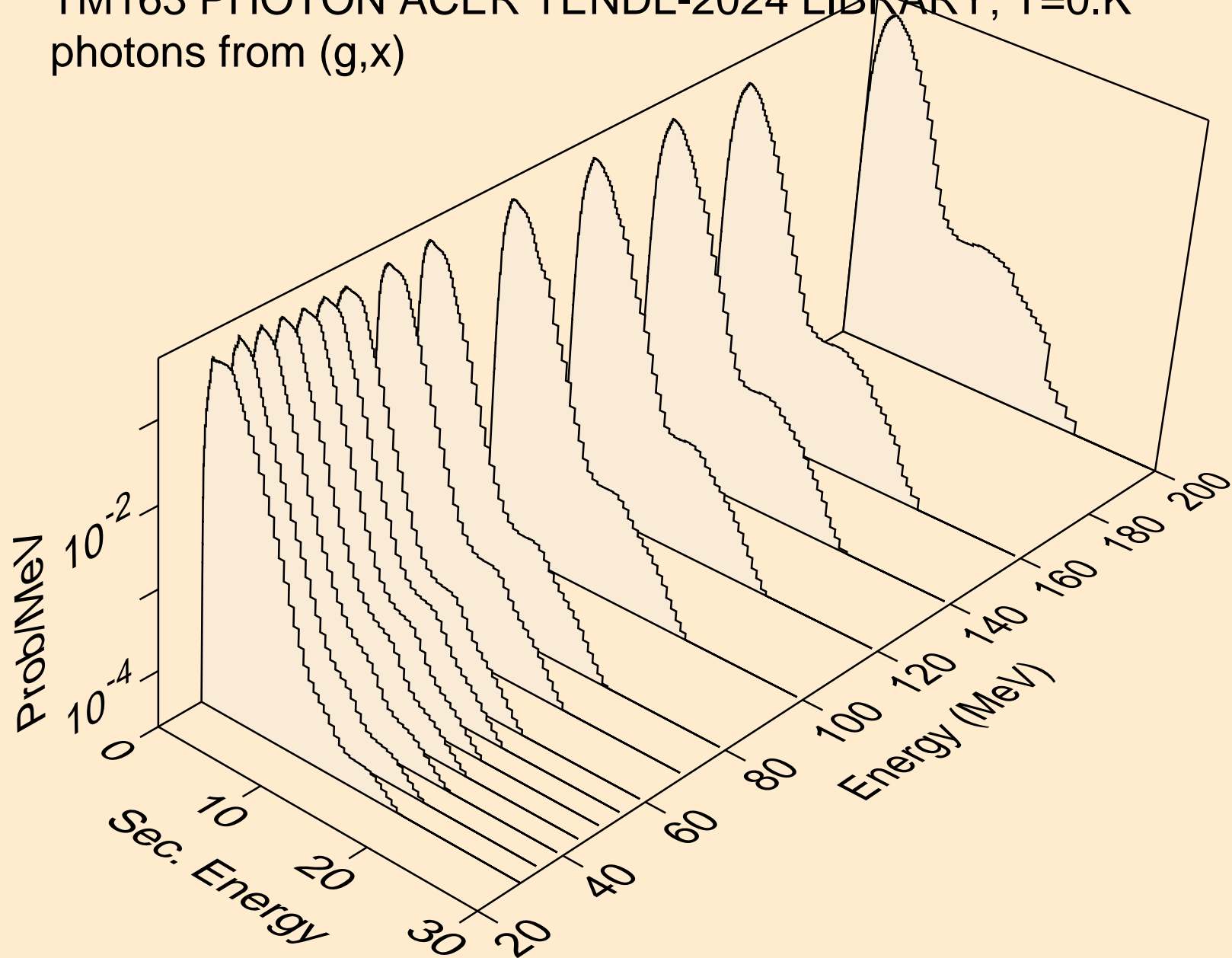

TM163 PHOTON ACER TENDL-2024 LIBRARY; T=0.K  
photons from (g,2n)

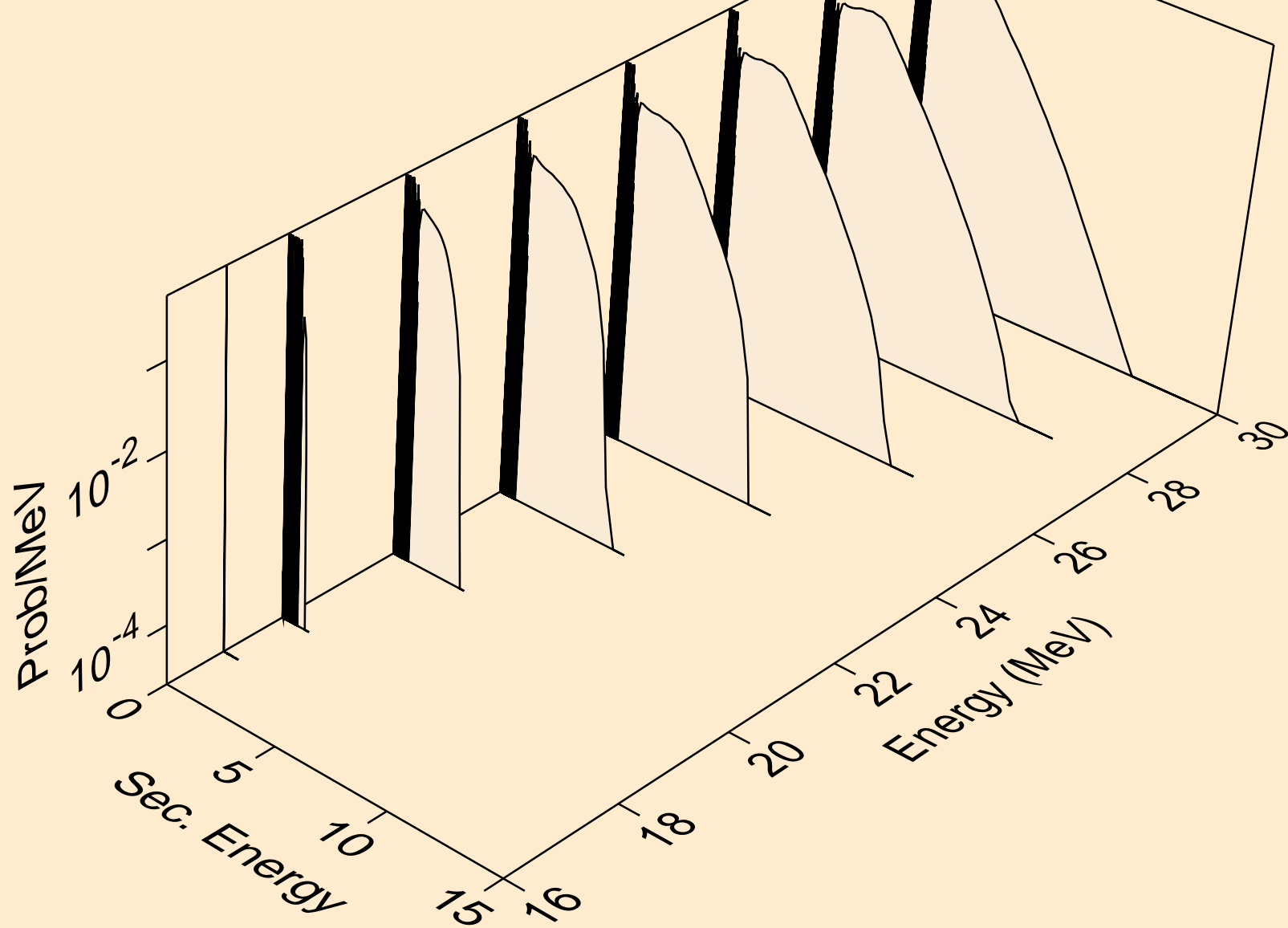

TM163 PHOTON ACER TENDL-2024 LIBRARY; T=0.K  
photons from (g,3n)

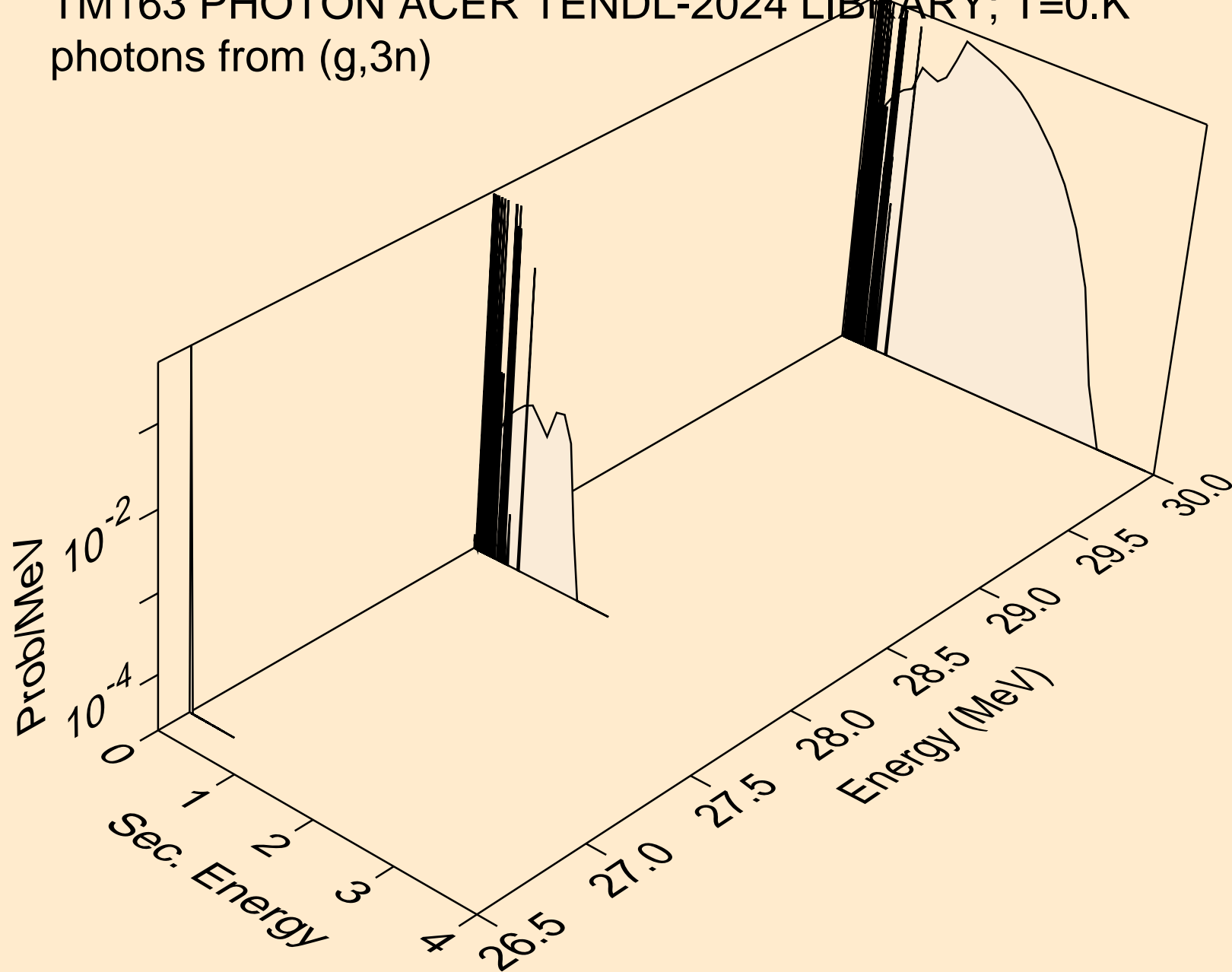

TM163 PHOTON ACER TENDL-2024 LIBRARY; T=0.K  
photons from (g,n\*)a

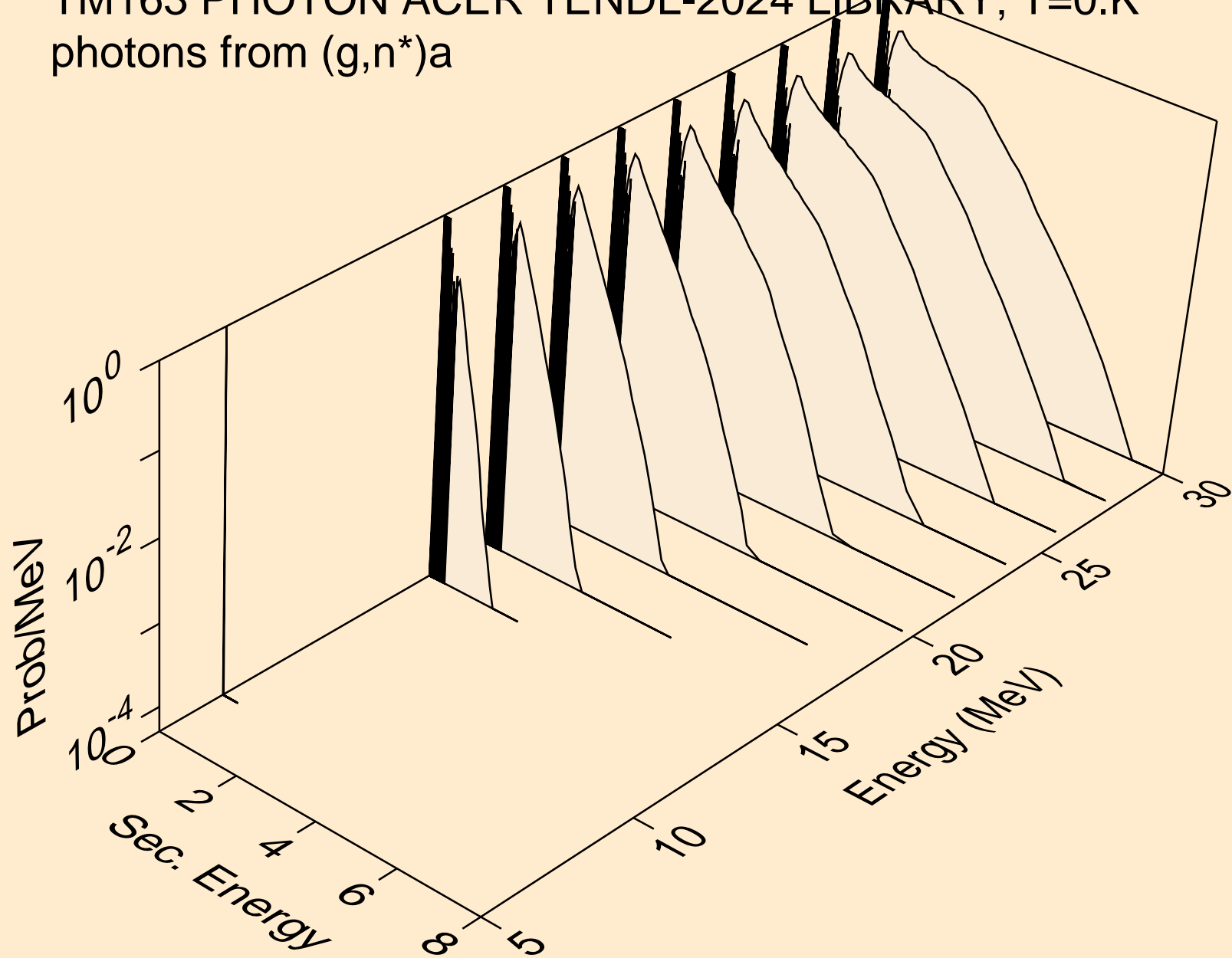

TM163 PHOTON ACER TENDL-2024 LIBRARY; T=0.K  
photons from (g,2n)a

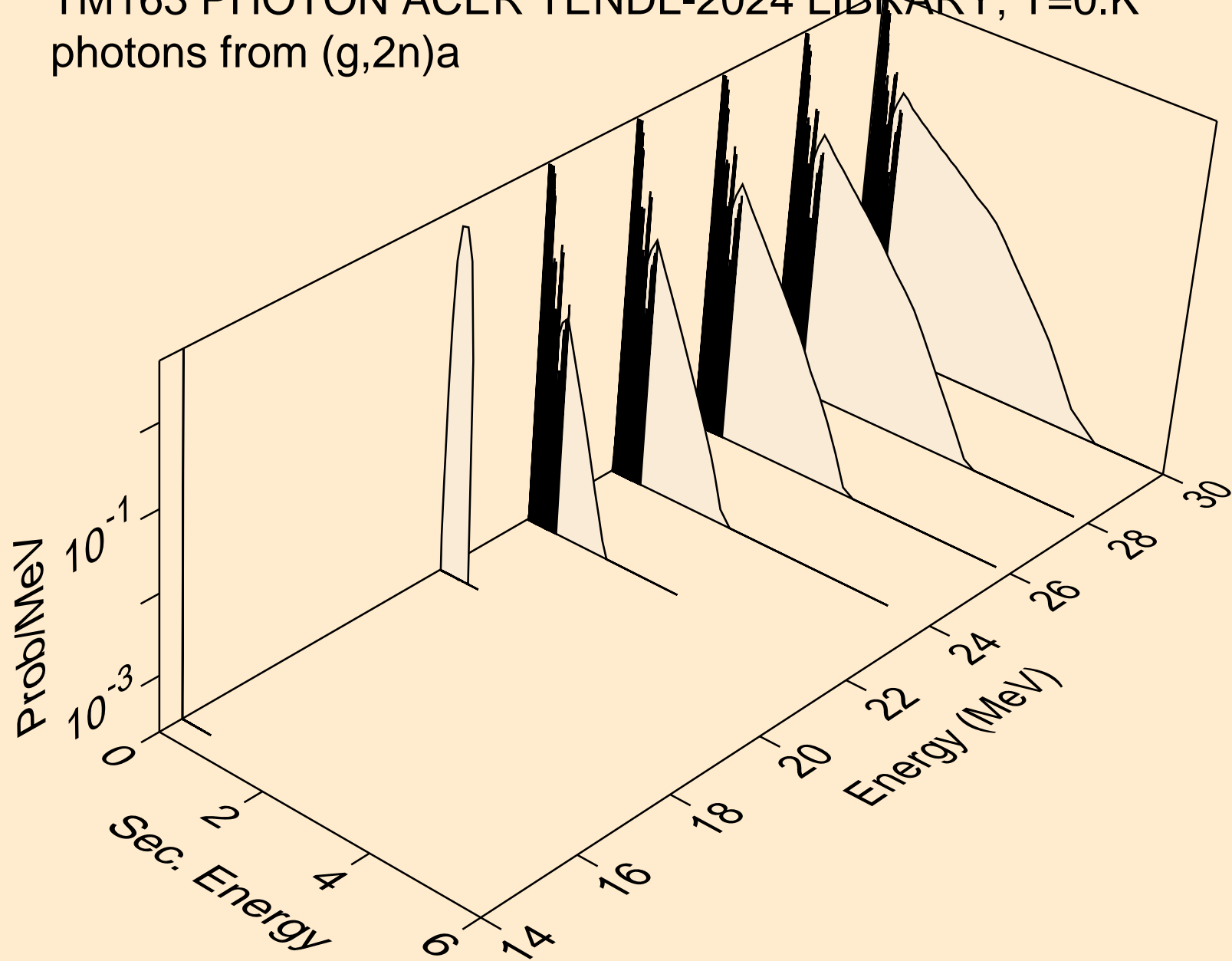

TM163 PHOTON ACER TENDL-2024 LIBRARY; T=0.K  
photons from (g,n\*)p

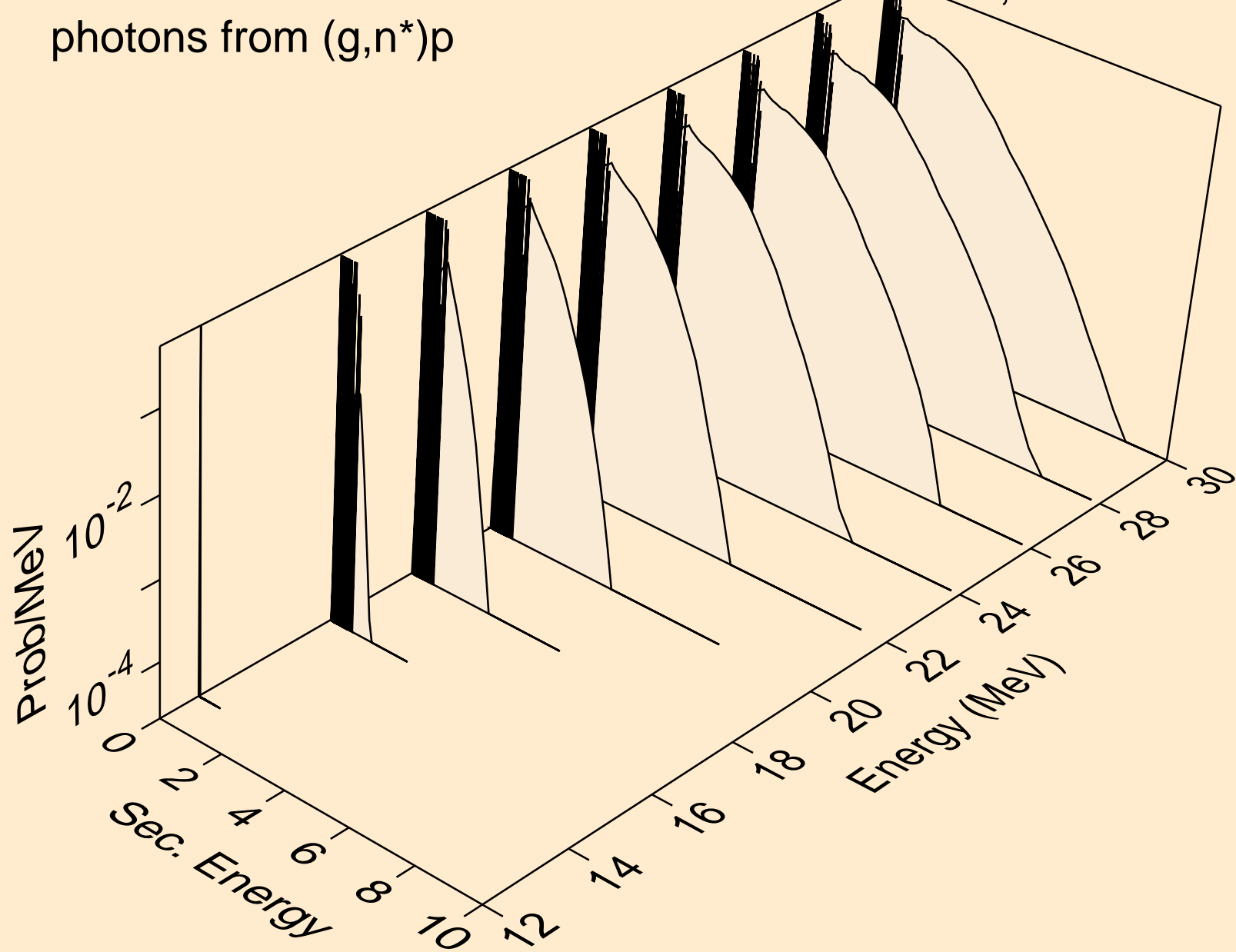

TM163 PHOTON ACER TENDL-2024 LIBRARY; T=0.K  
photons from (g,n\*)d

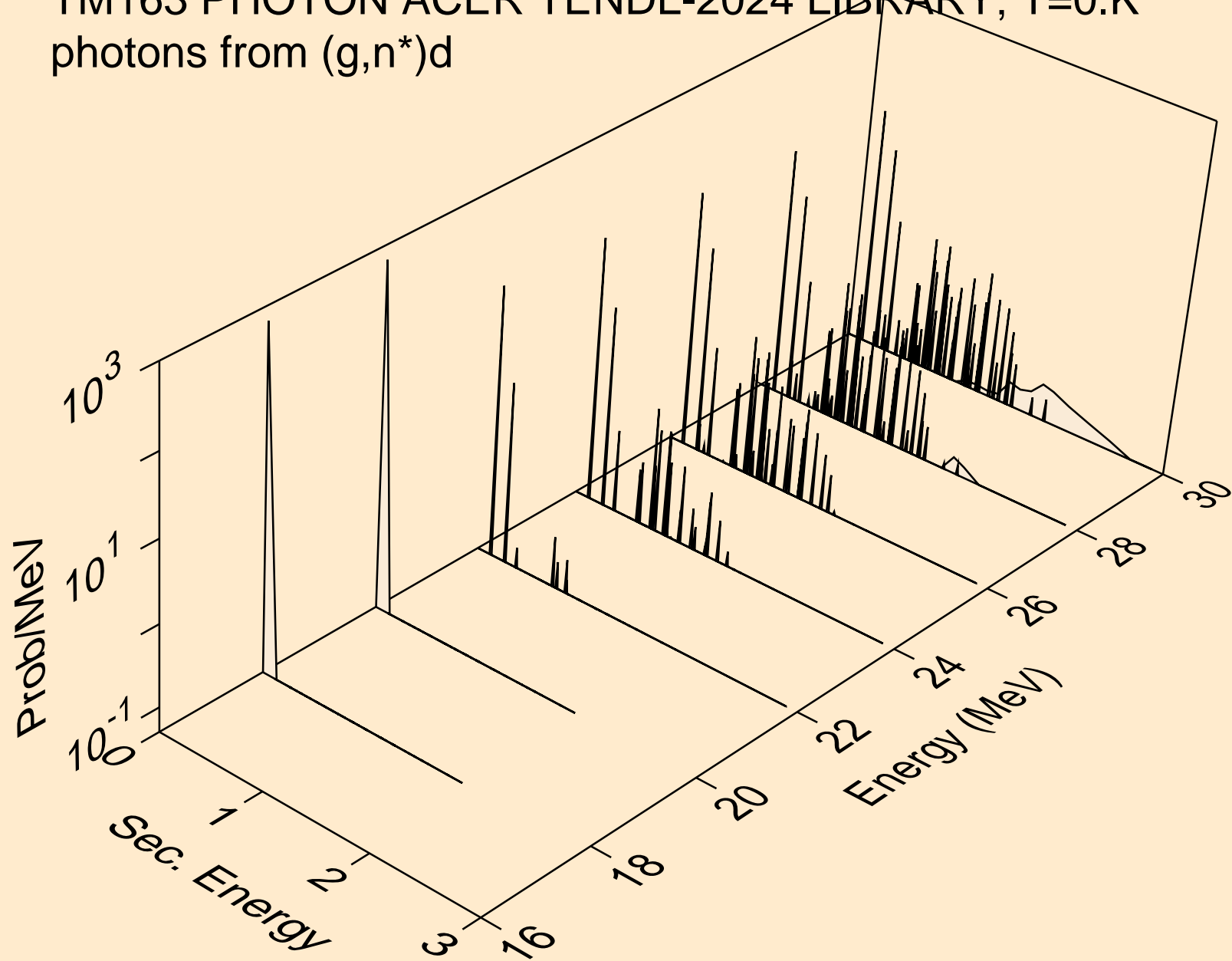

TM163 PHOTON ACER TENDL-2024 LIBRARY; T=0.K  
photons from (g,n\*)t

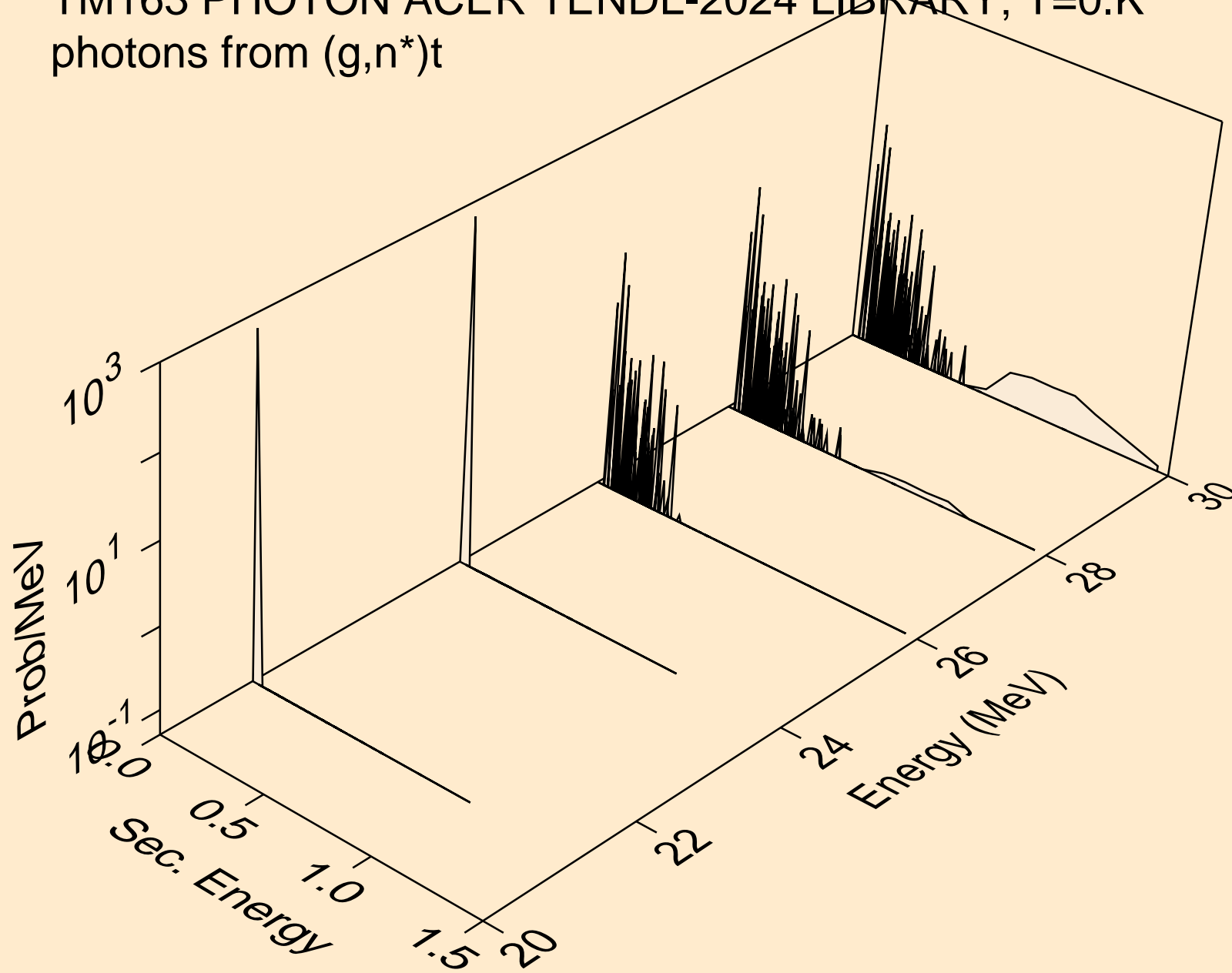

TM163 PHOTON ACER TENDL-2024 LIBRARY; T=0.K  
photons from (g,2np)

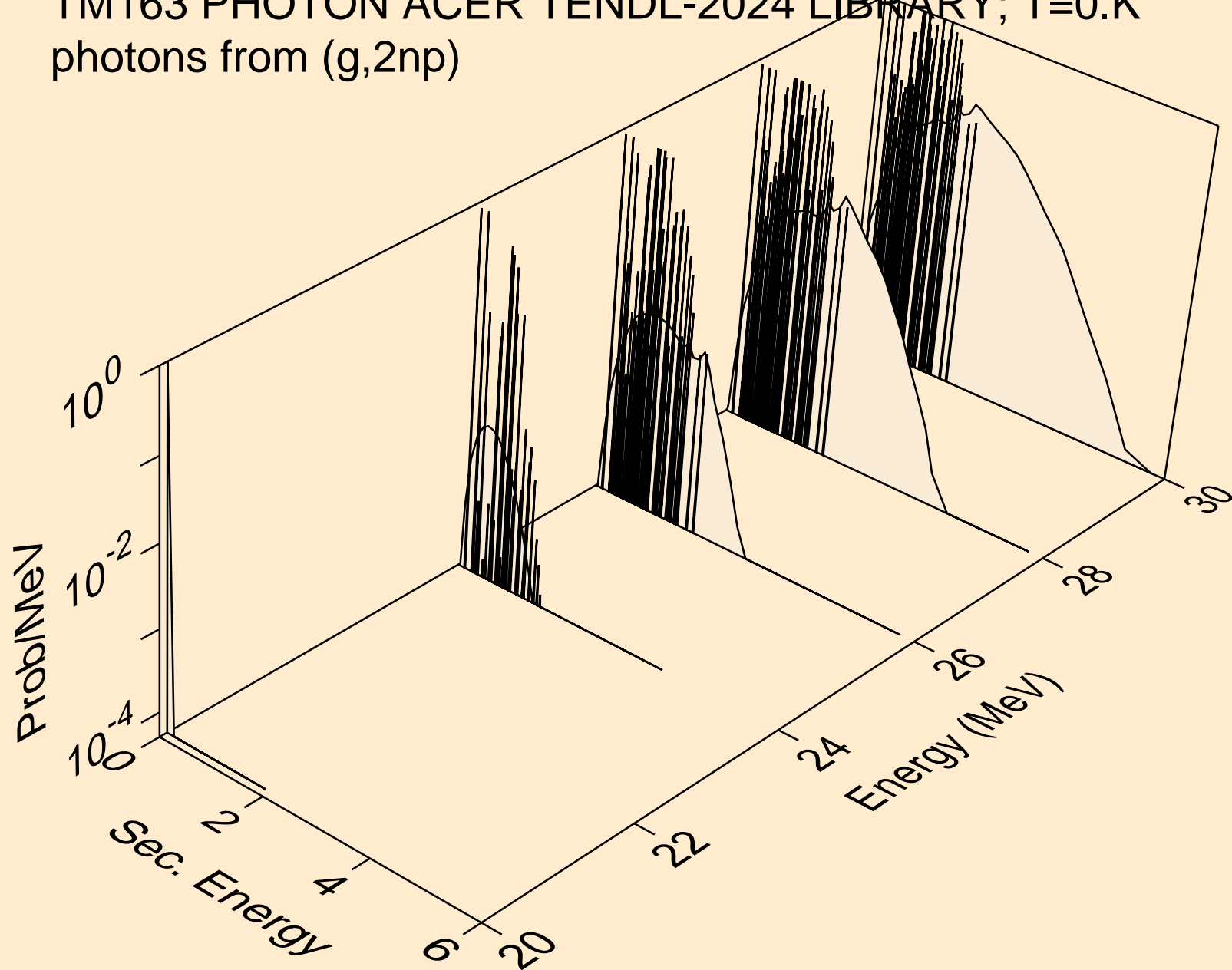

TM163 PHOTON ACER TENDL-2024 LIBRARY; T=0.K  
photons from (g,npa)

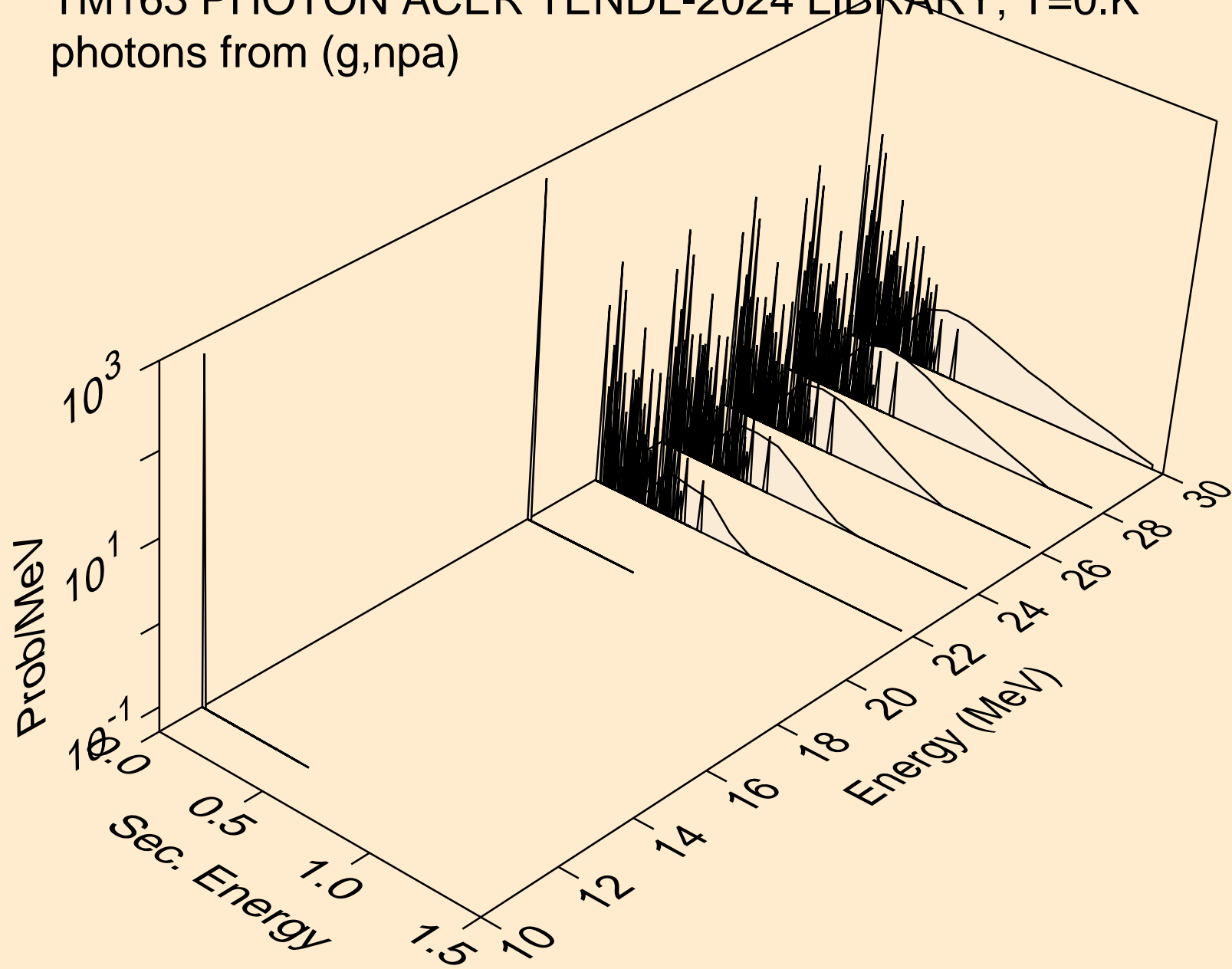

TM163 PHOTON ACER TENDL-2024 LIBRARY; T=0.K  
photons from (g,n\*c)

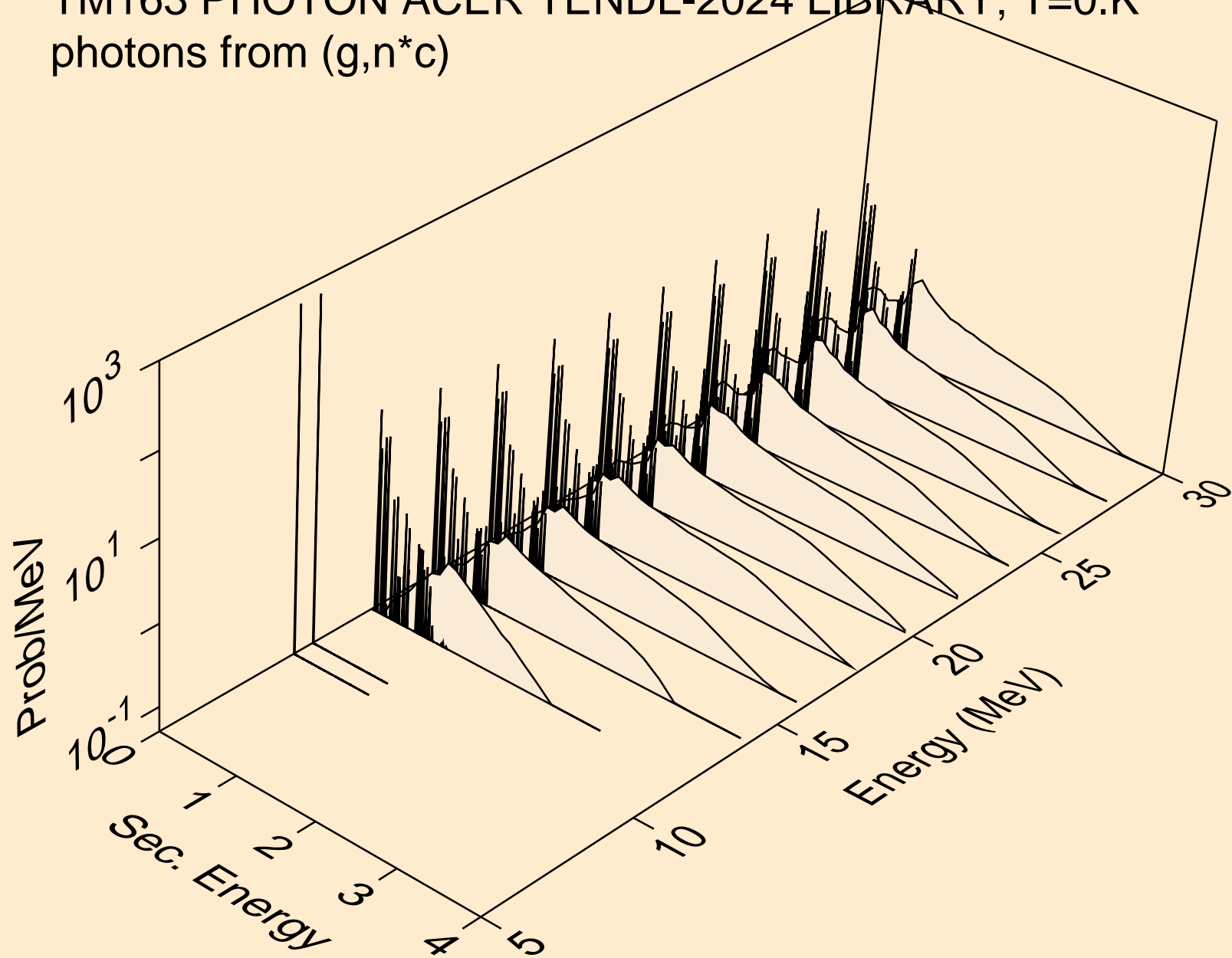

TM163 PHOTON ACER TENDL-2024 LIBRARY; T=0.K  
photons from (g,gma)

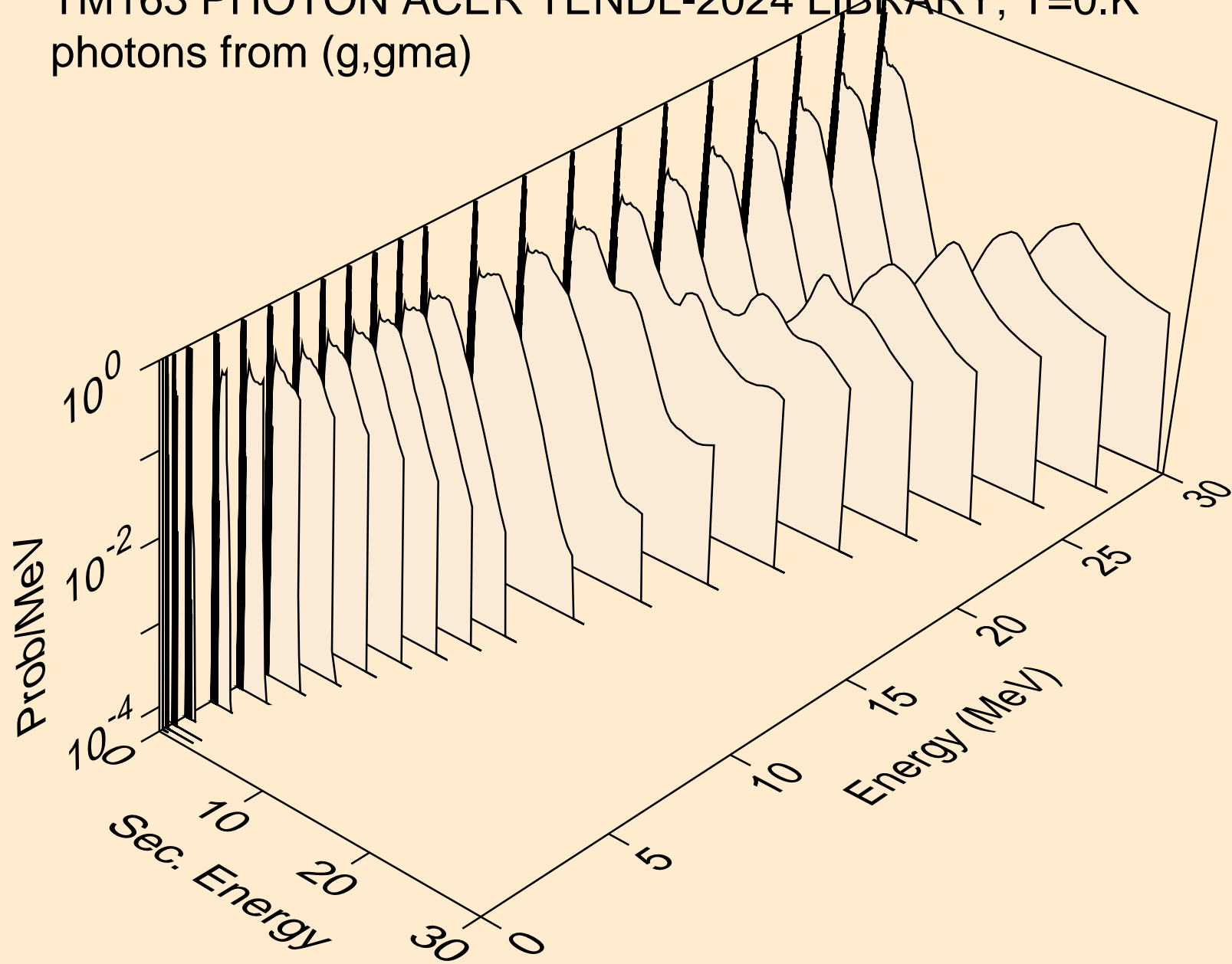

TM163 PHOTON ACER TENDL-2024 LIBRARY; T=0.K  
photons from (g,p)

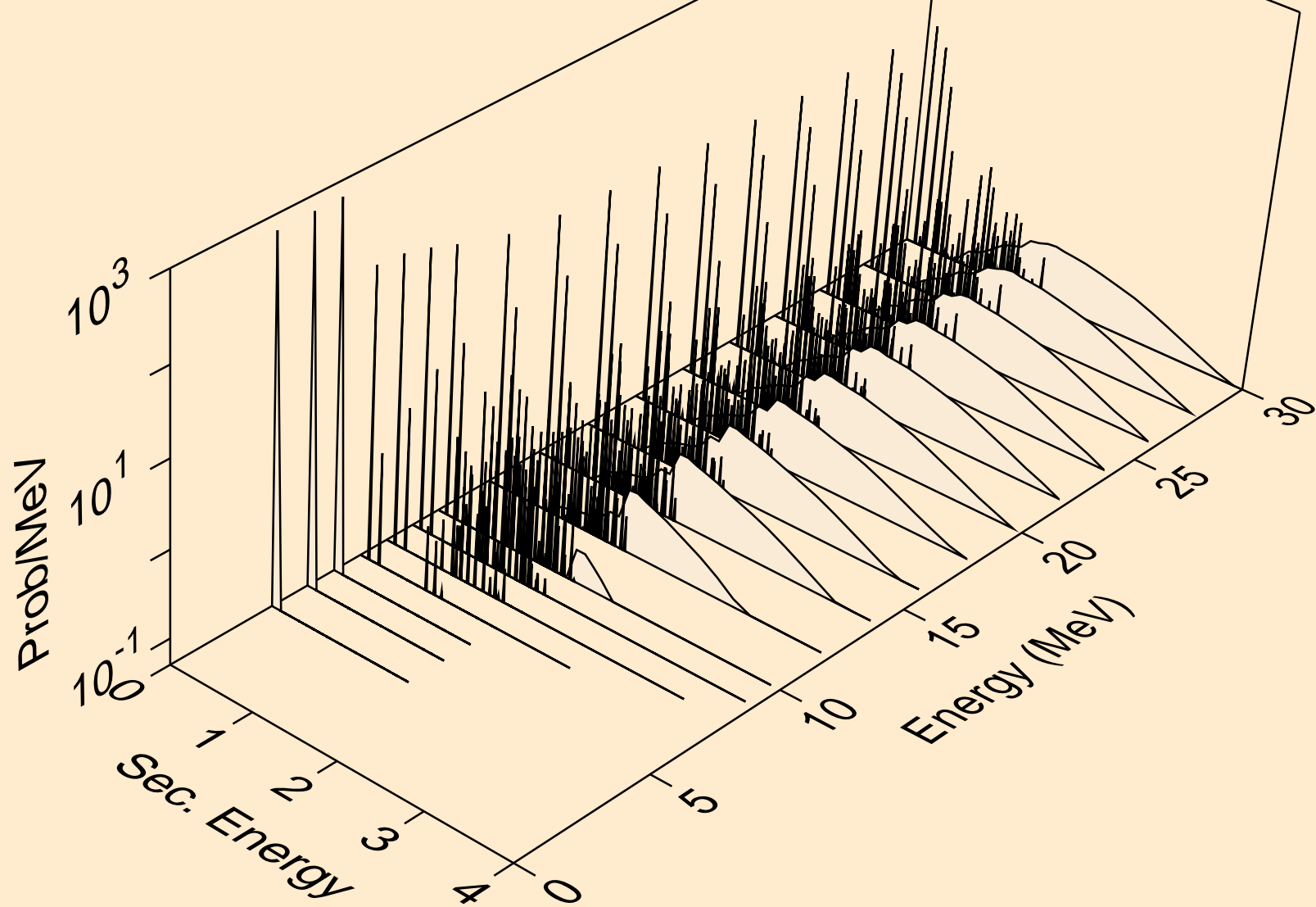

TM163 PHOTON ACER TENDL-2024 LIBRARY; T=0.K  
photons from (g,d)

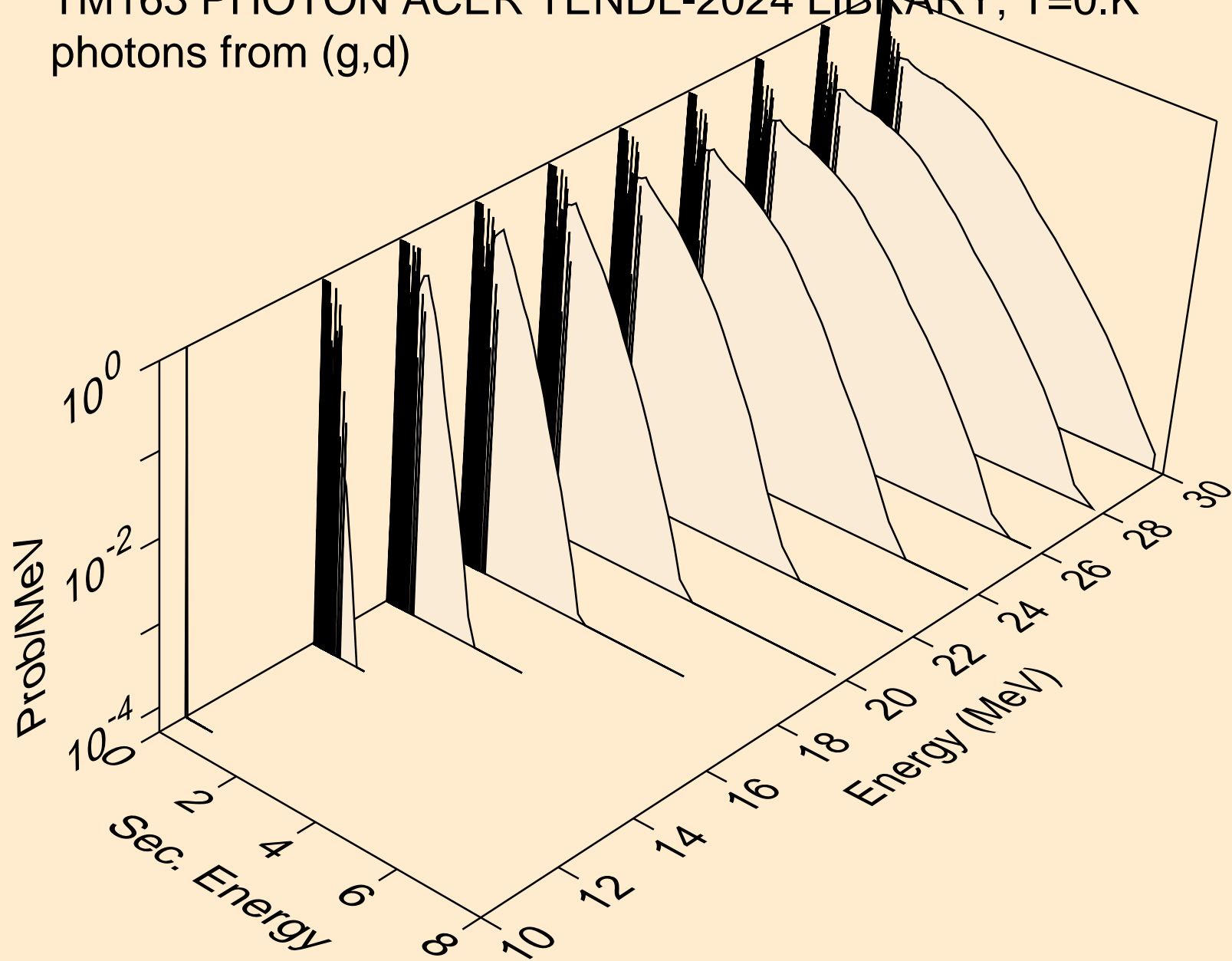

TM163 PHOTON ACER TENDL-2024 LIBRARY; T=0.K  
photons from (g,t)

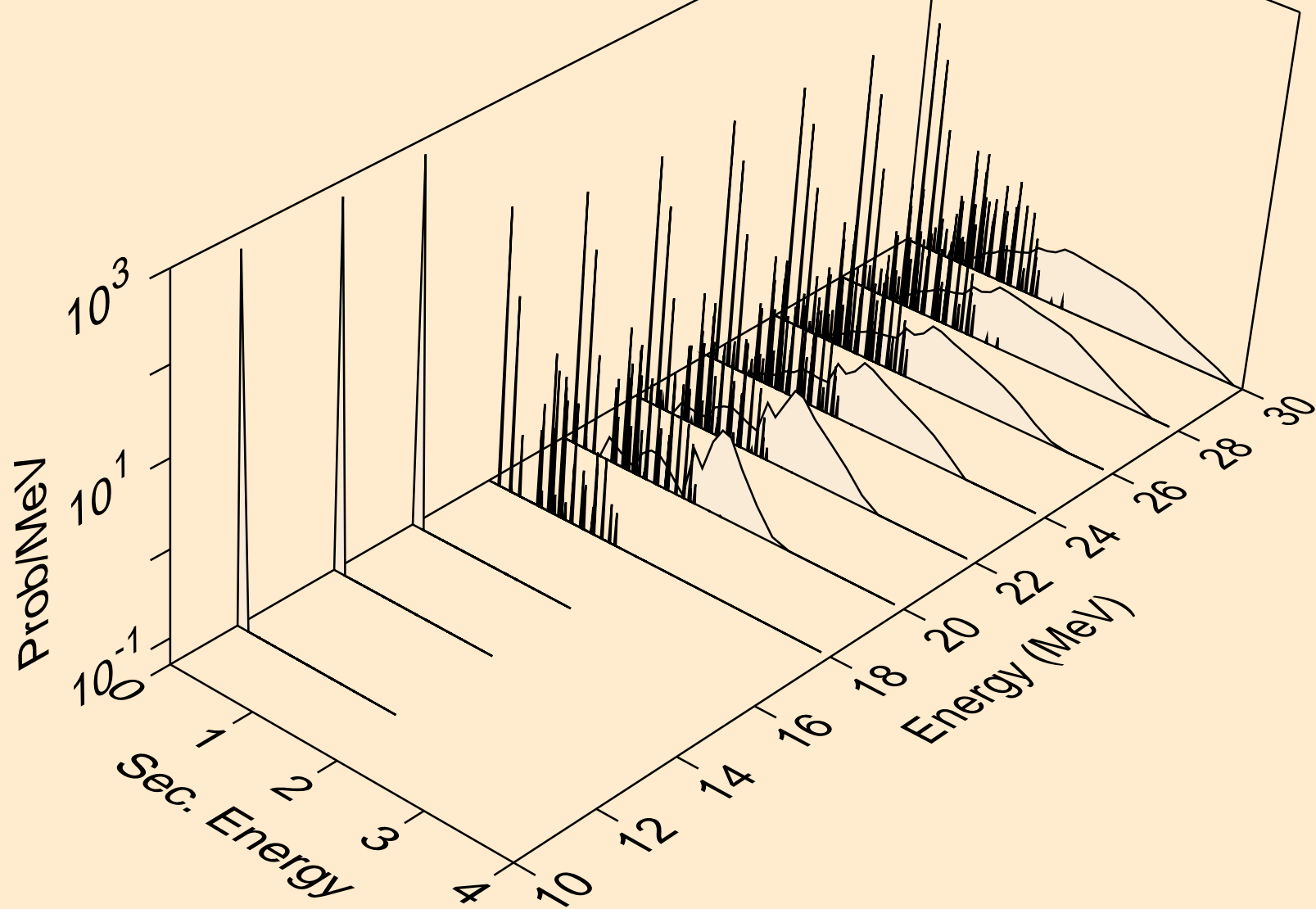

TM163 PHOTON ACER TENDL-2024 LIBRARY; T=0.K  
photons from (g,a)

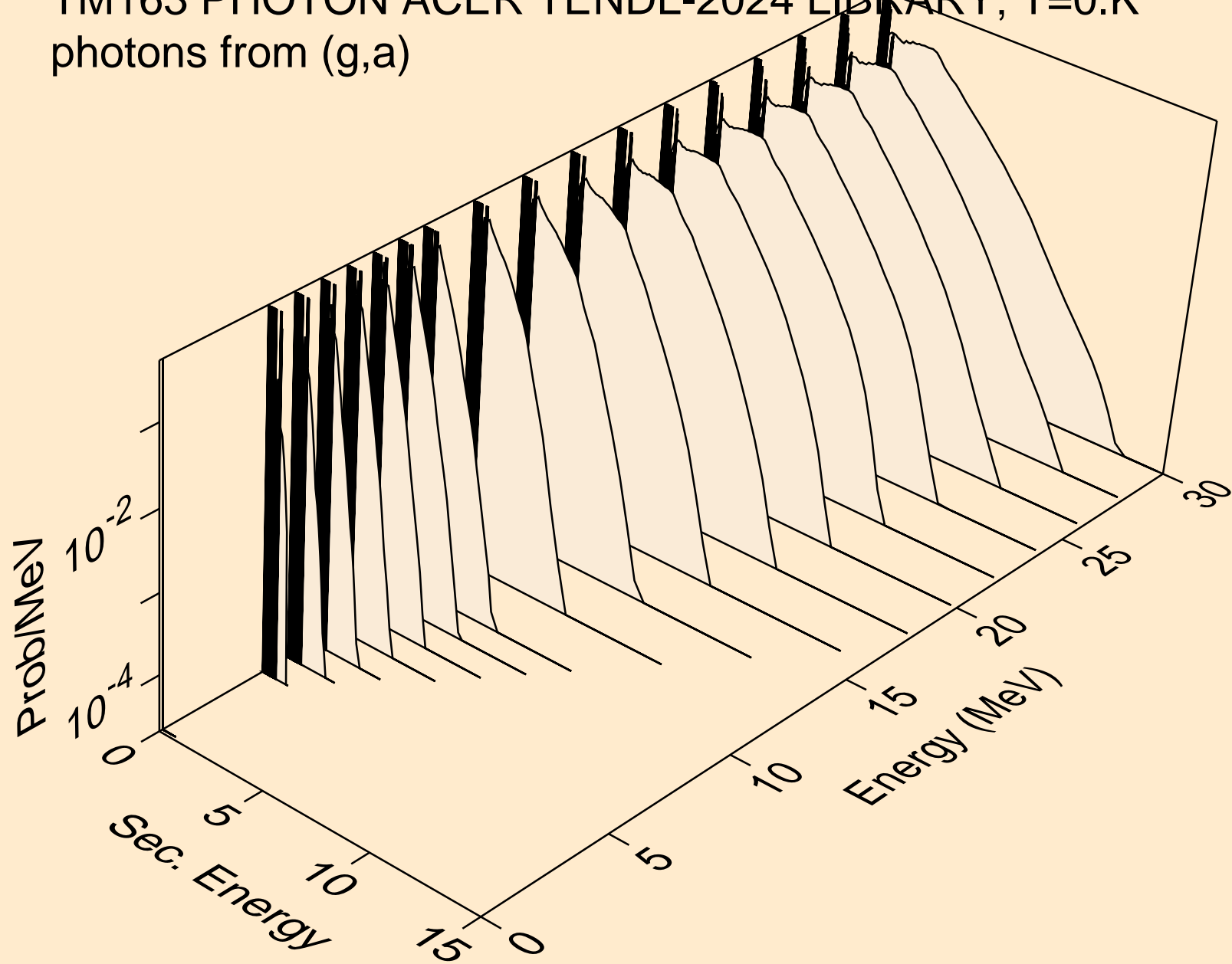

TM163 PHOTON ACER TENDL-2024 LIBRARY; T=0.K  
photons from (g,2p)

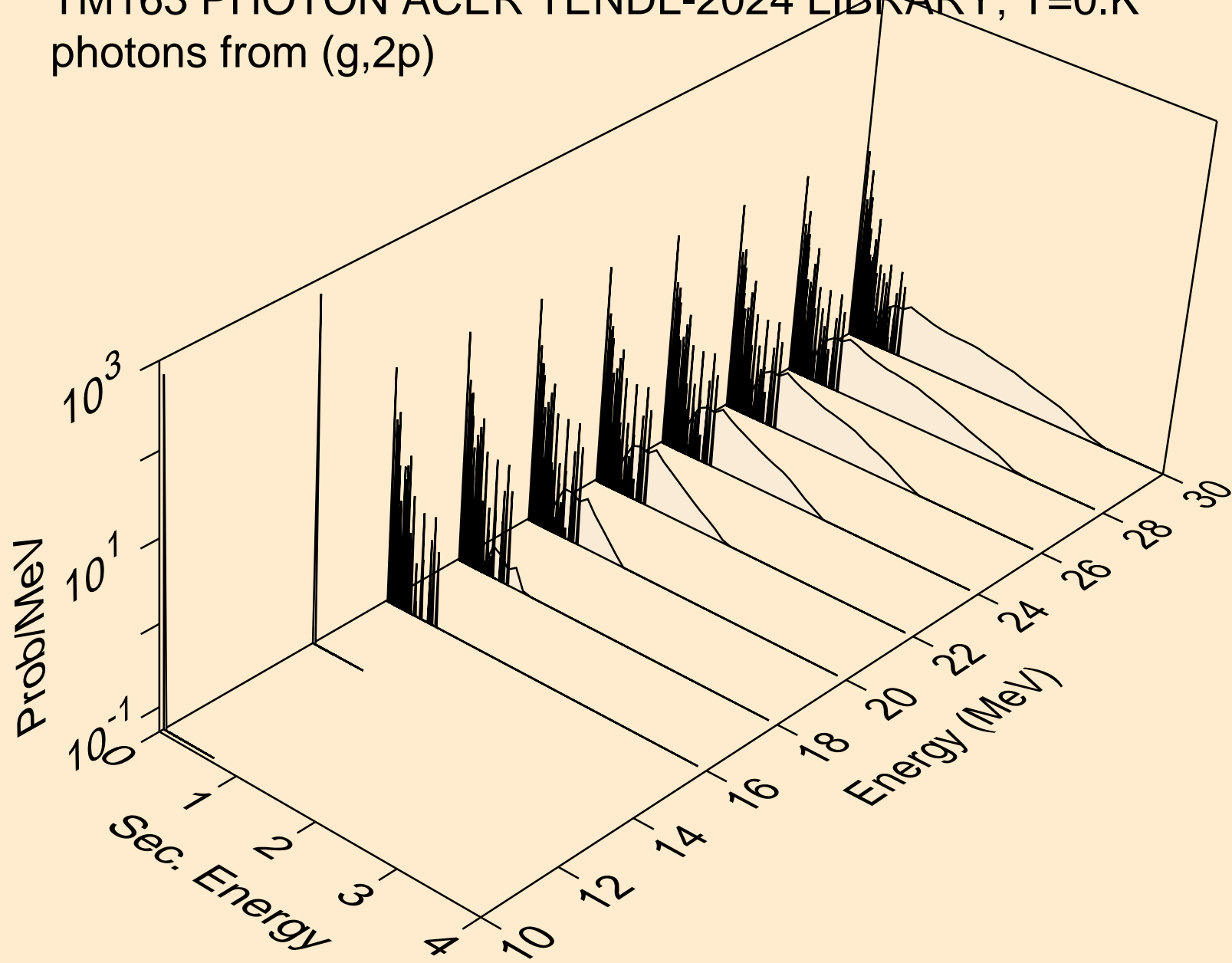

TM163 PHOTON ACER TENDL-2024 LIBRARY; T=0.K  
photons from (g,pa)

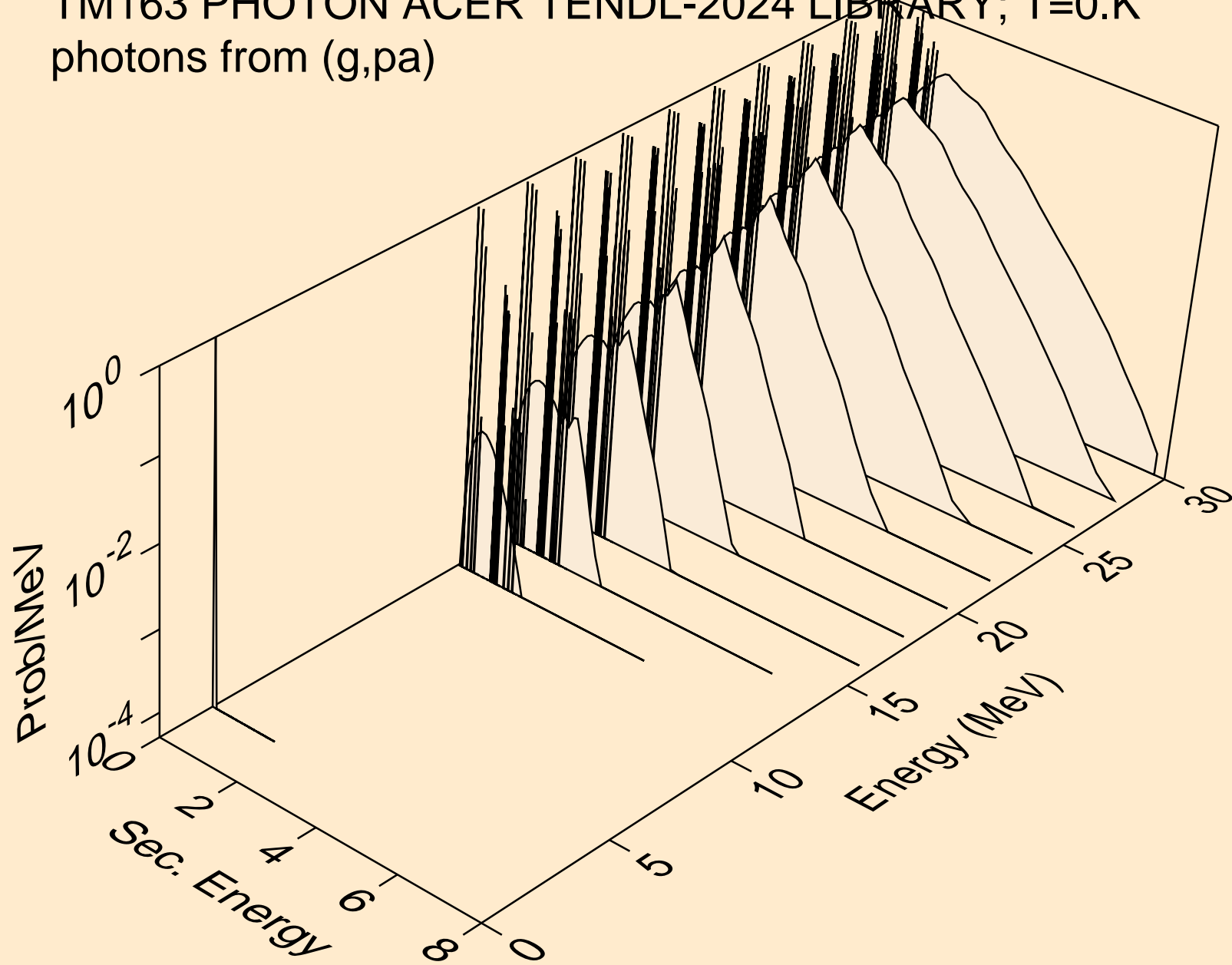

TM163 PHOTON ACER TENDL-2024 LIBRARY; T=0.K  
protons from (g,x)

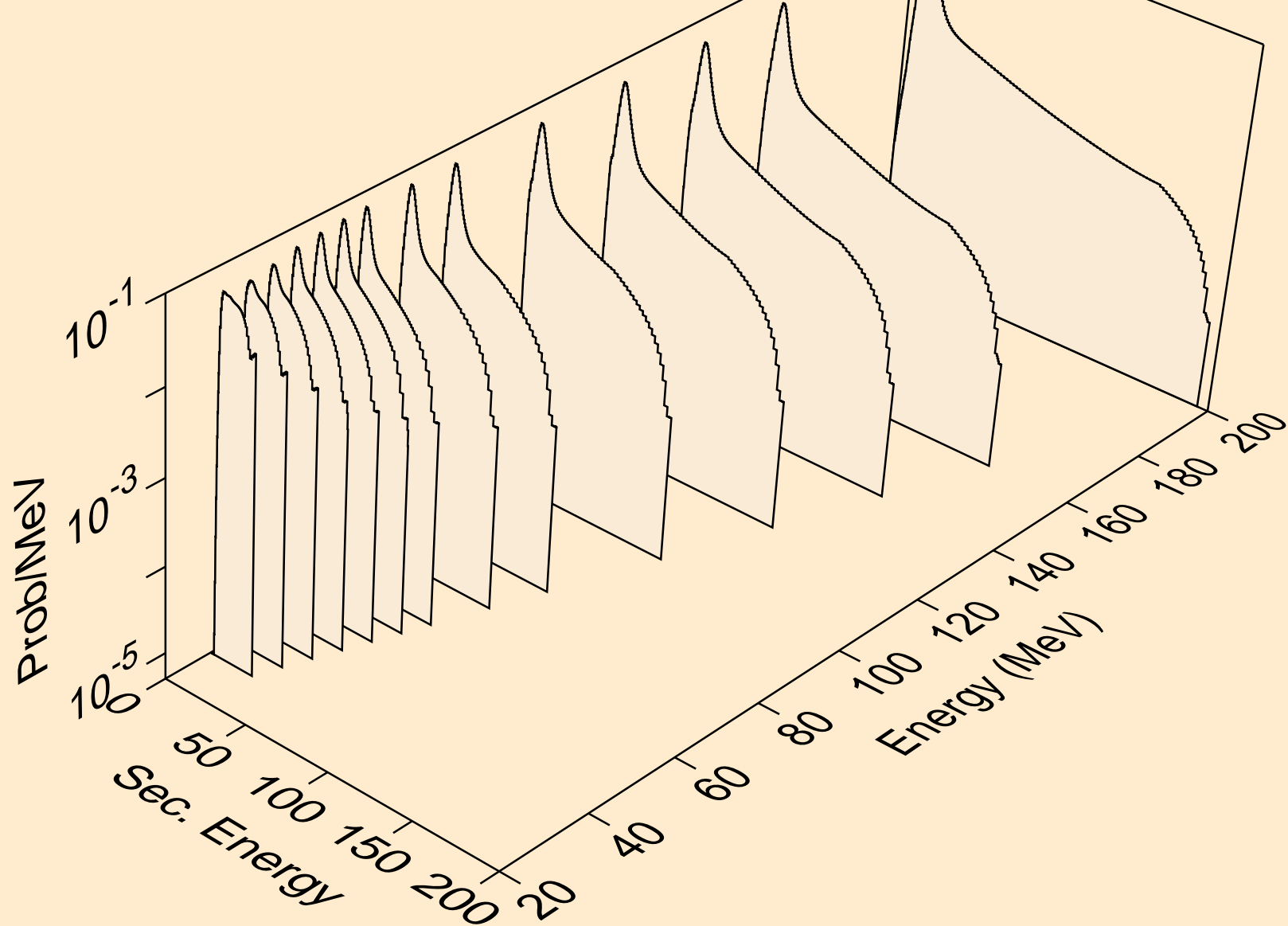

TM163 PHOTON ACER TENDL-2024 LIBRARY; T=0.K  
protons from (g,n\*)p

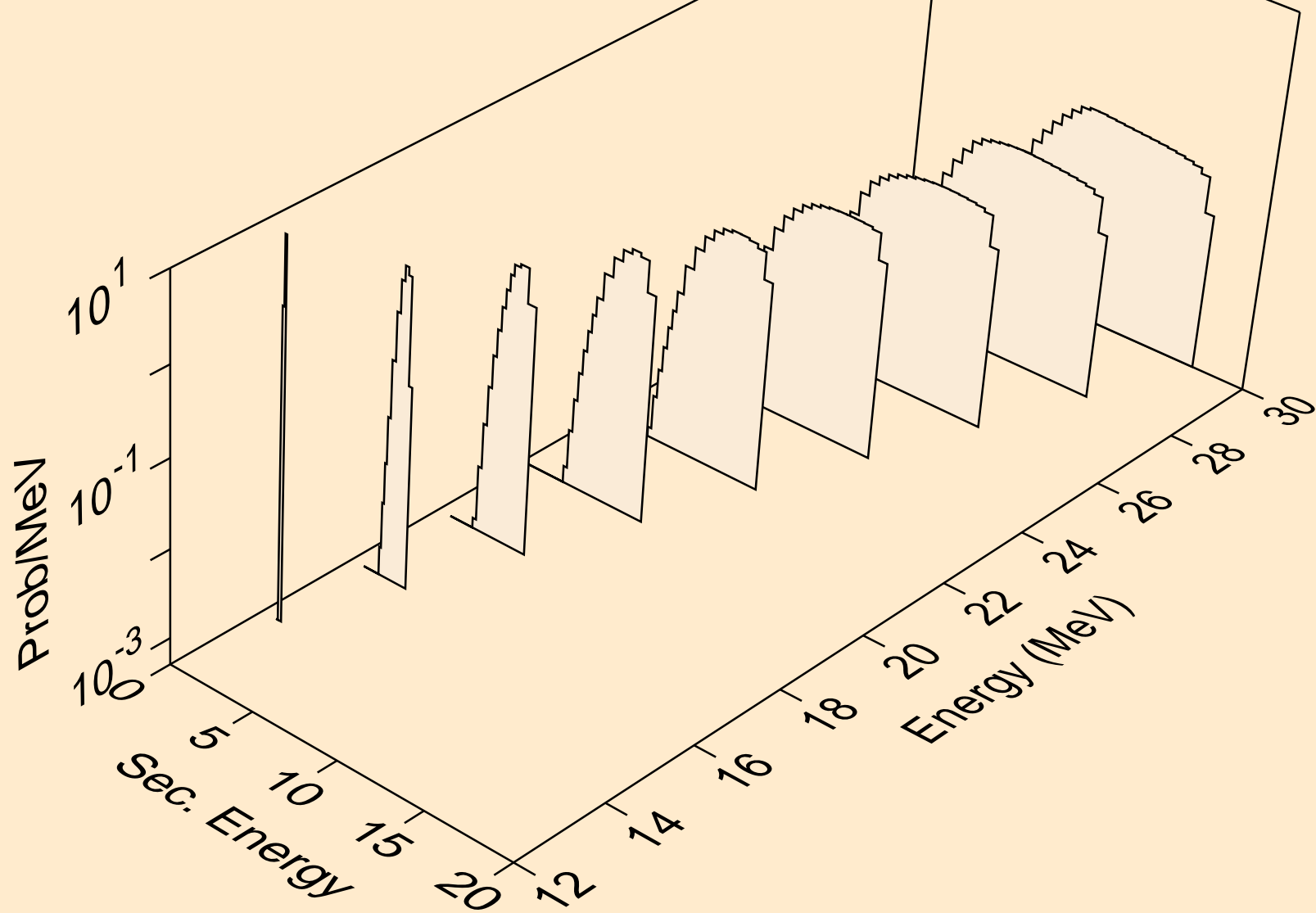

TM163 PHOTON ACER TENDL-2024 LIBRARY; T=0.K  
protons from (g,2np)

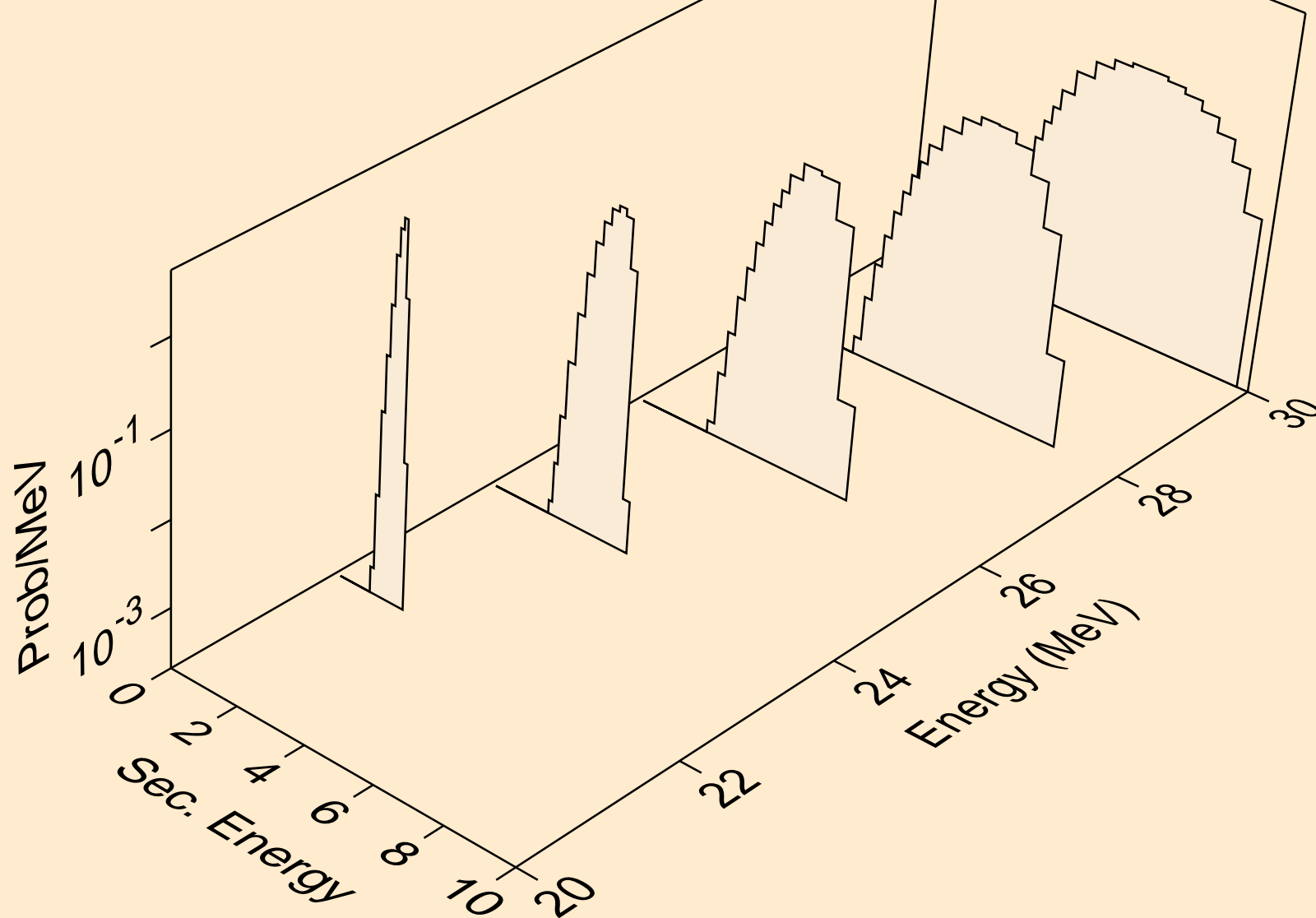

TM163 PHOTON ACER TENDL-2024 LIBRARY; T=0.K  
protons from (g,npa)

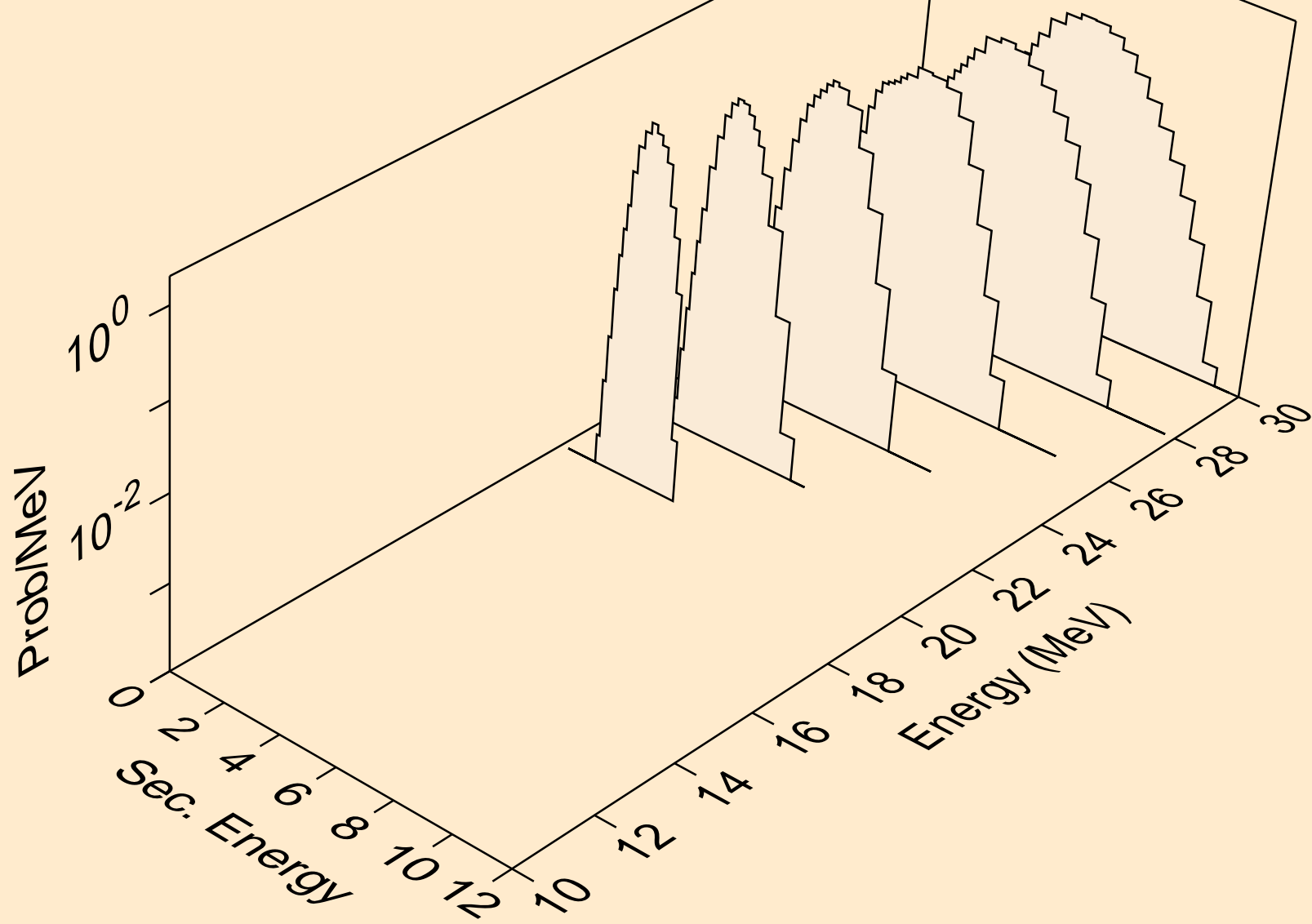

TM163 PHOTON ACER TENDL-2024 LIBRARY; T=0.K  
protons from (g,p)

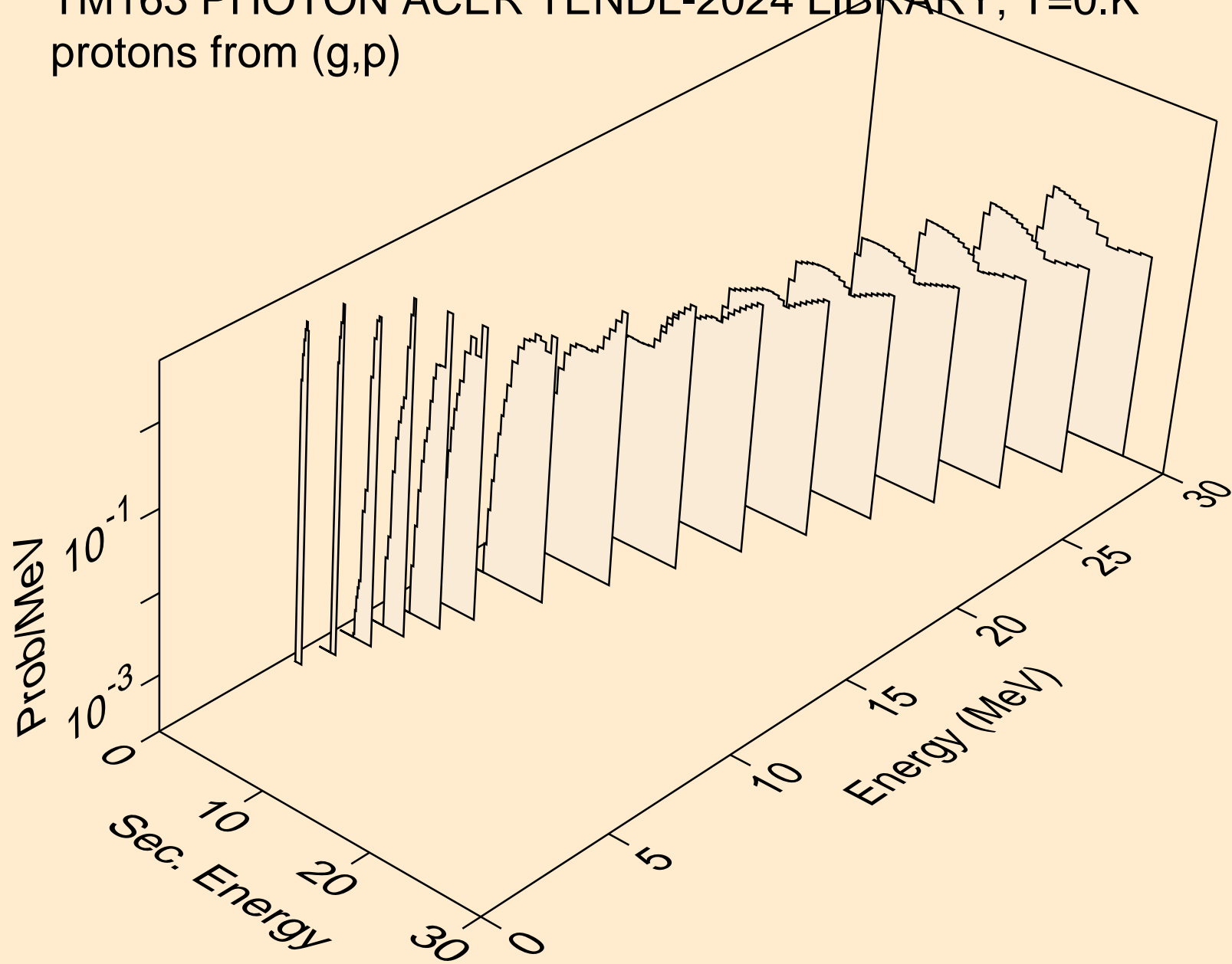

TM163 PHOTON ACER TENDL-2024 LIBRARY; T=0.K  
protons from (g,2p)

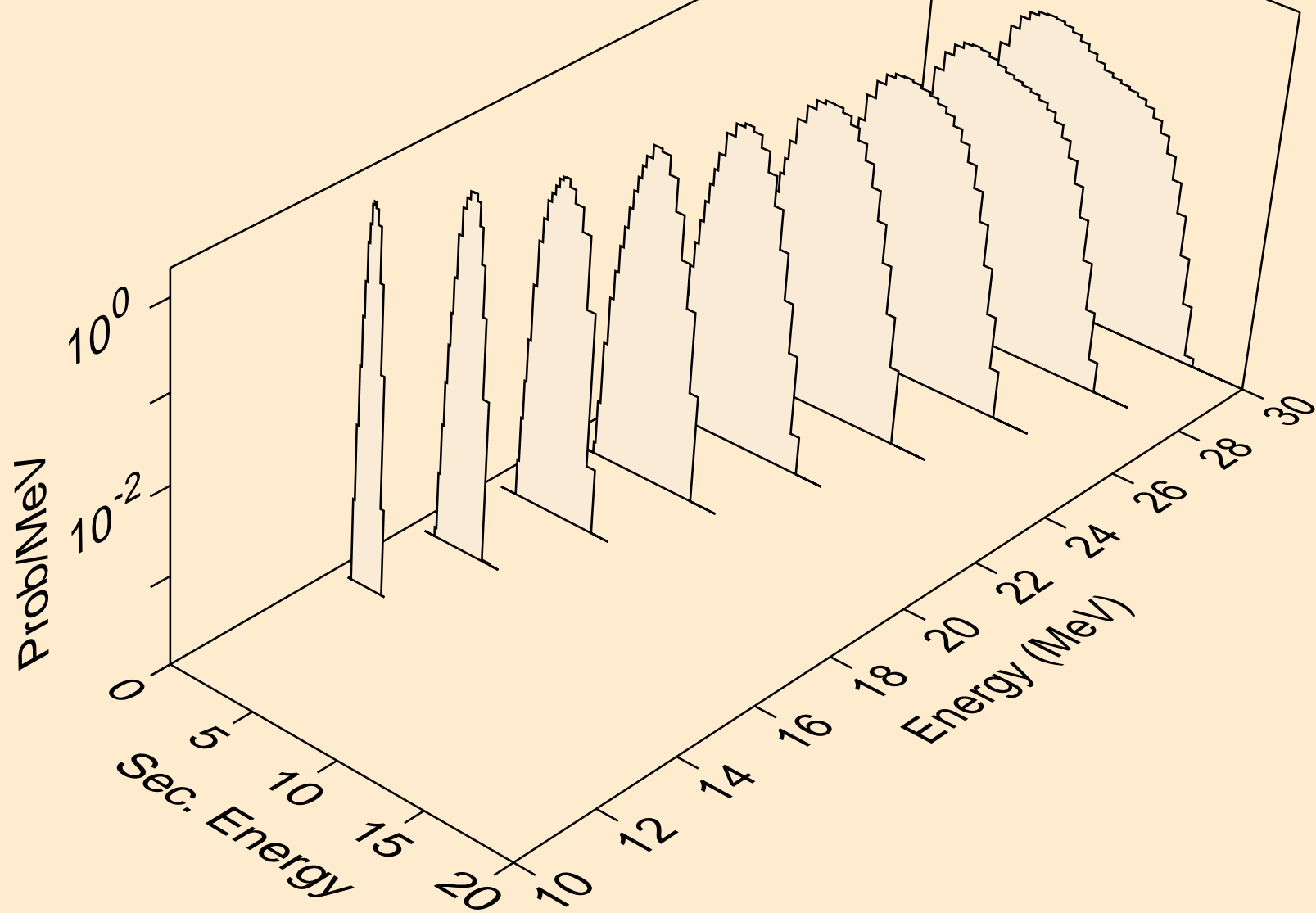

TM163 PHOTON ACER TENDL-2024 LIBRARY; T=0.K  
protons from (g,pa)

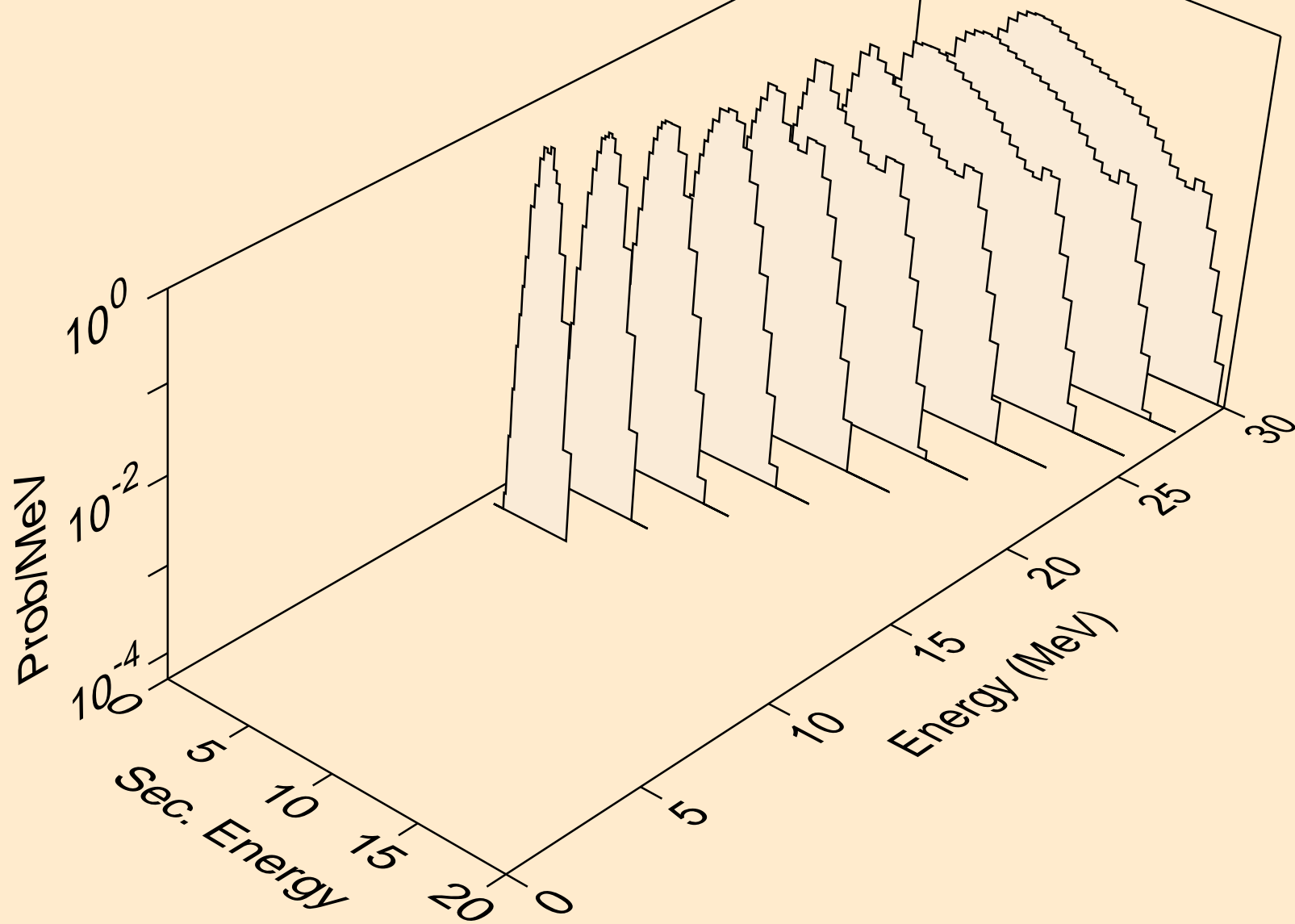

TM163 PHOTON ACER TENDL-2024 LIBRARY; T=0.K  
deuterons from (g,x)

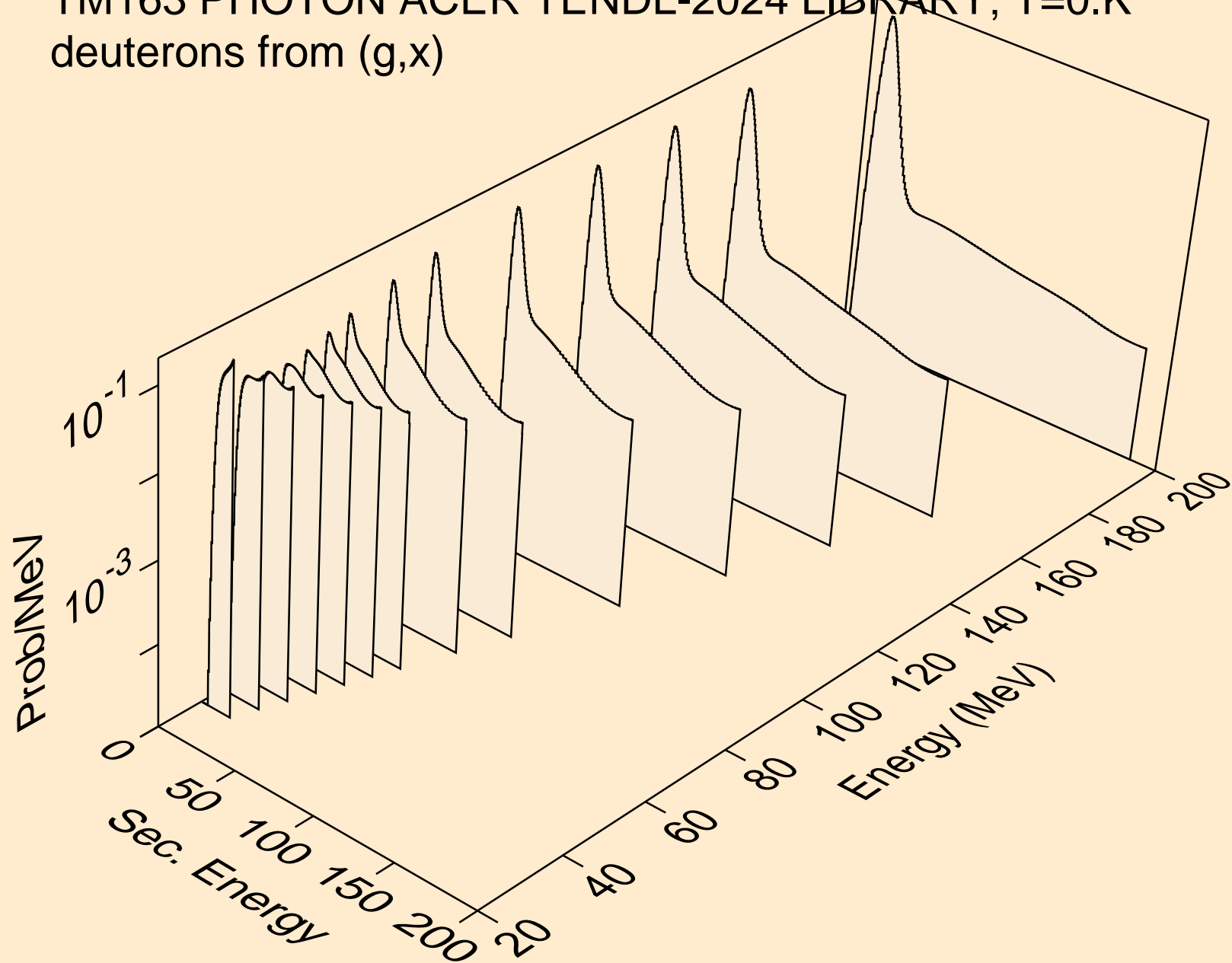

TM163 PHOTON ACER TENDL-2024 LIBRARY; T=0.K  
deuterons from (g,n\*)d

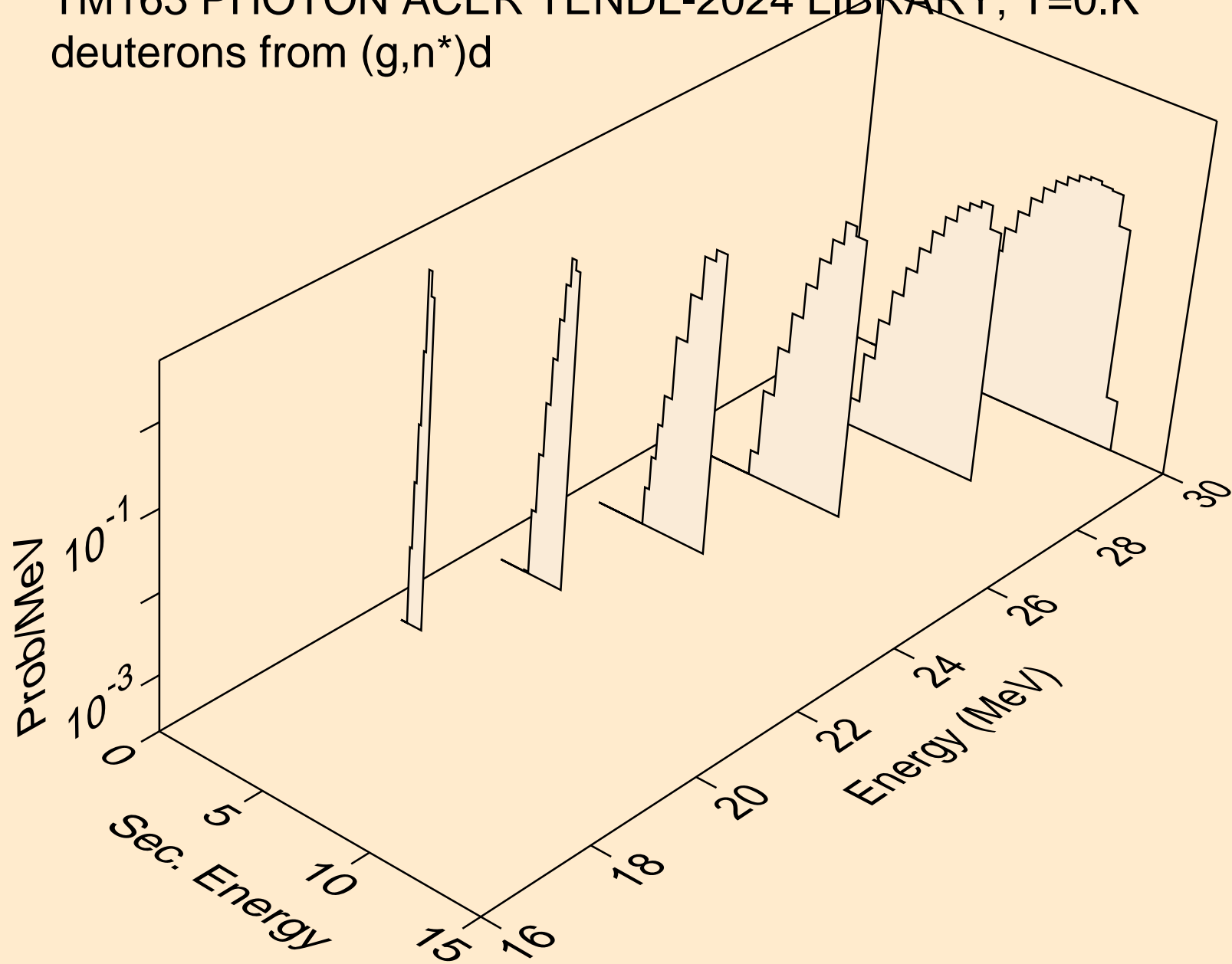

TM163 PHOTON ACER TENDL-2024 LIBRARY; T=0.K  
deuterons from (g,d)

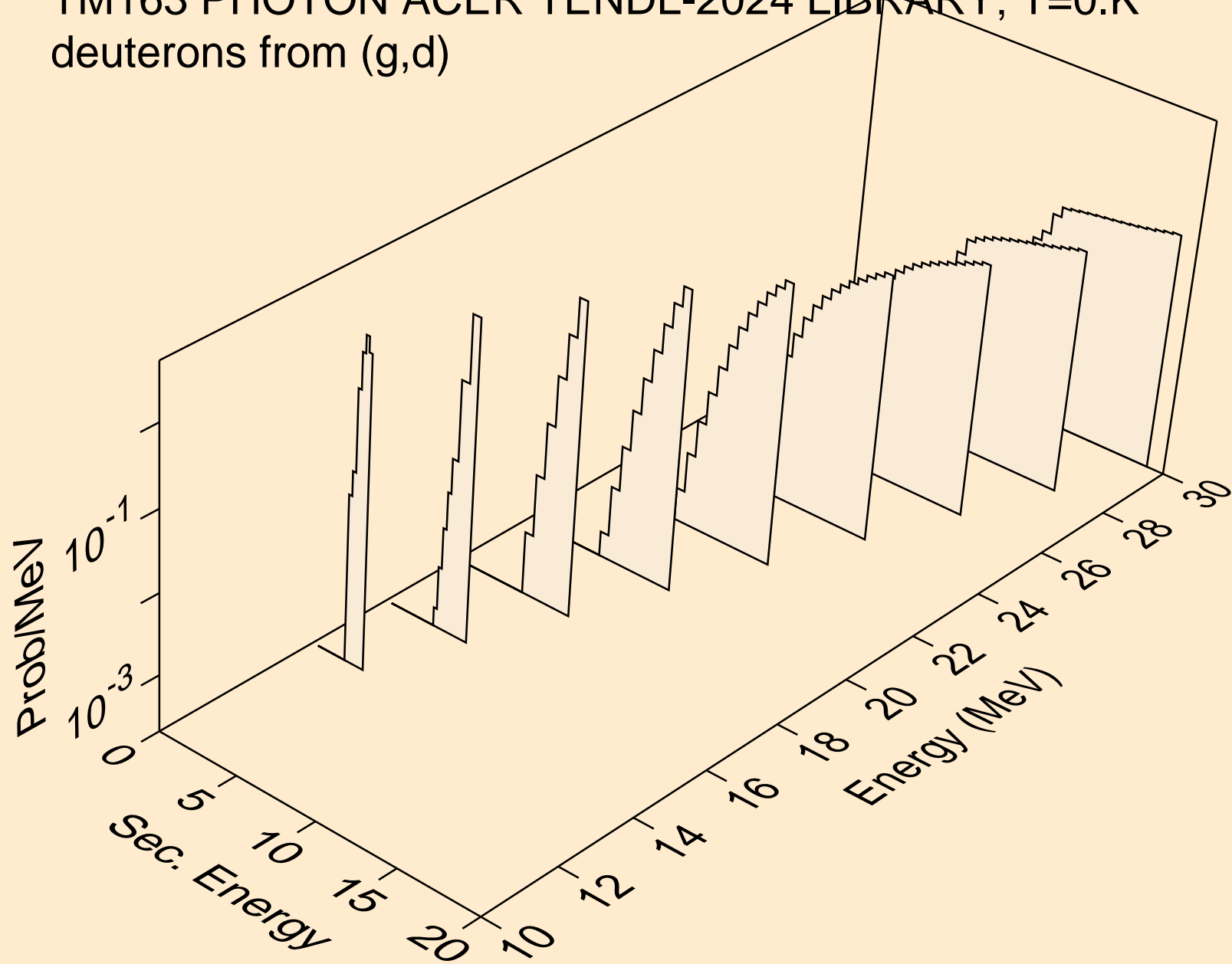

TM163 PHOTON ACER TENDL-2024 LIBRARY; T=0.K  
tritons from (g,x)

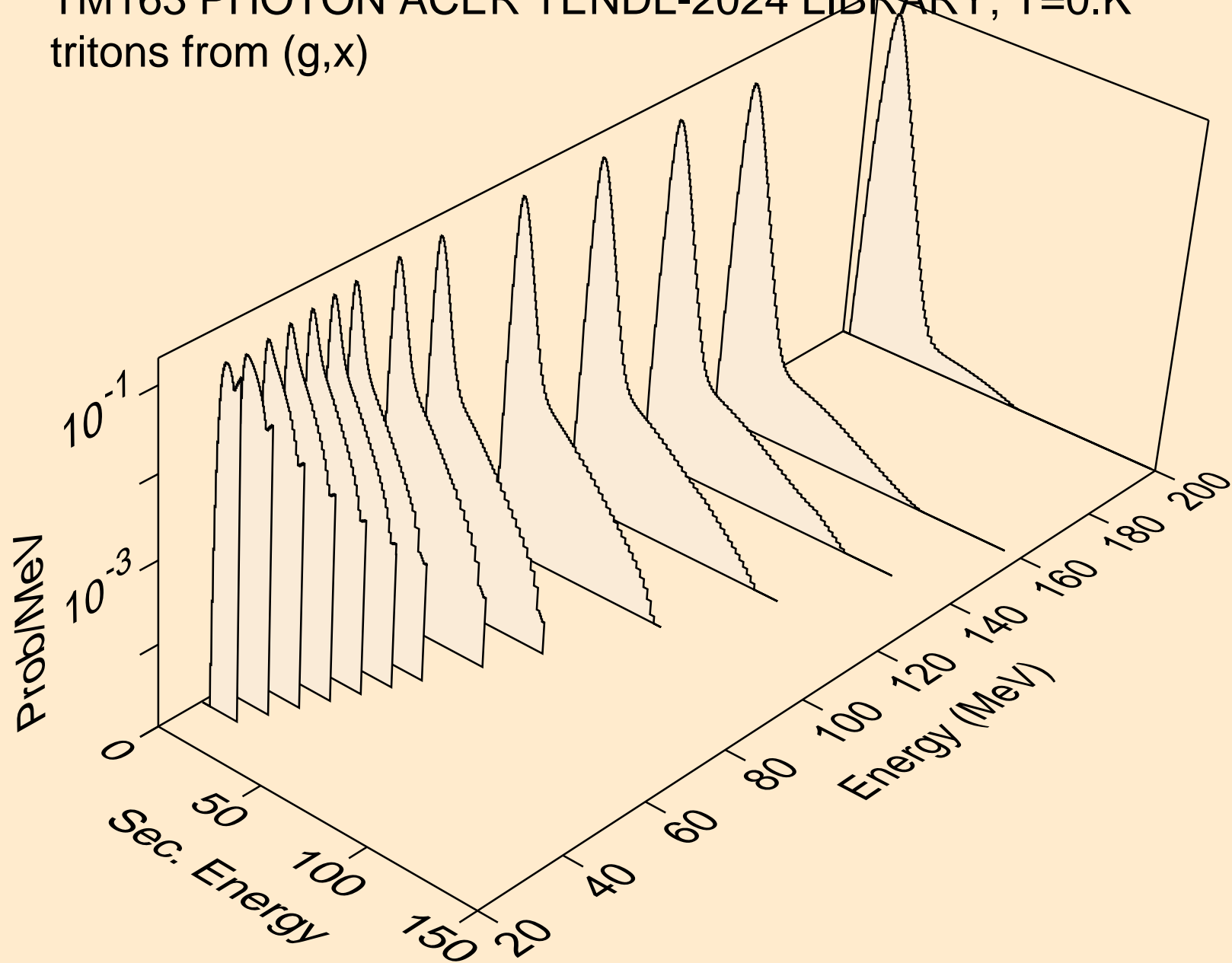

TM163 PHOTON ACER TENDL-2024 LIBRARY; T=0.K  
tritons from (g,n\*)t

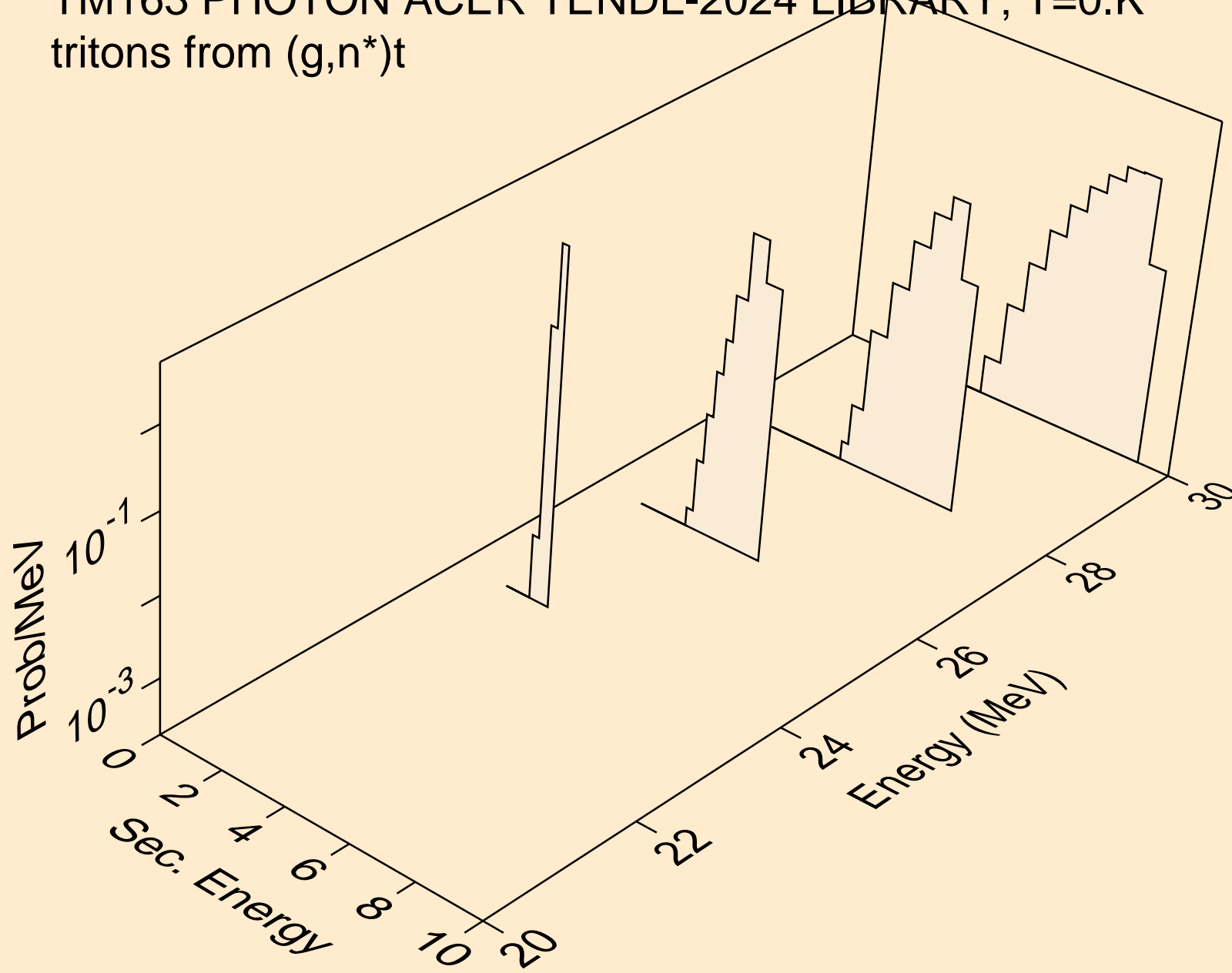

TM163 PHOTON ACER TENDL-2024 LIBRARY; T=0.K  
tritons from (g,t)

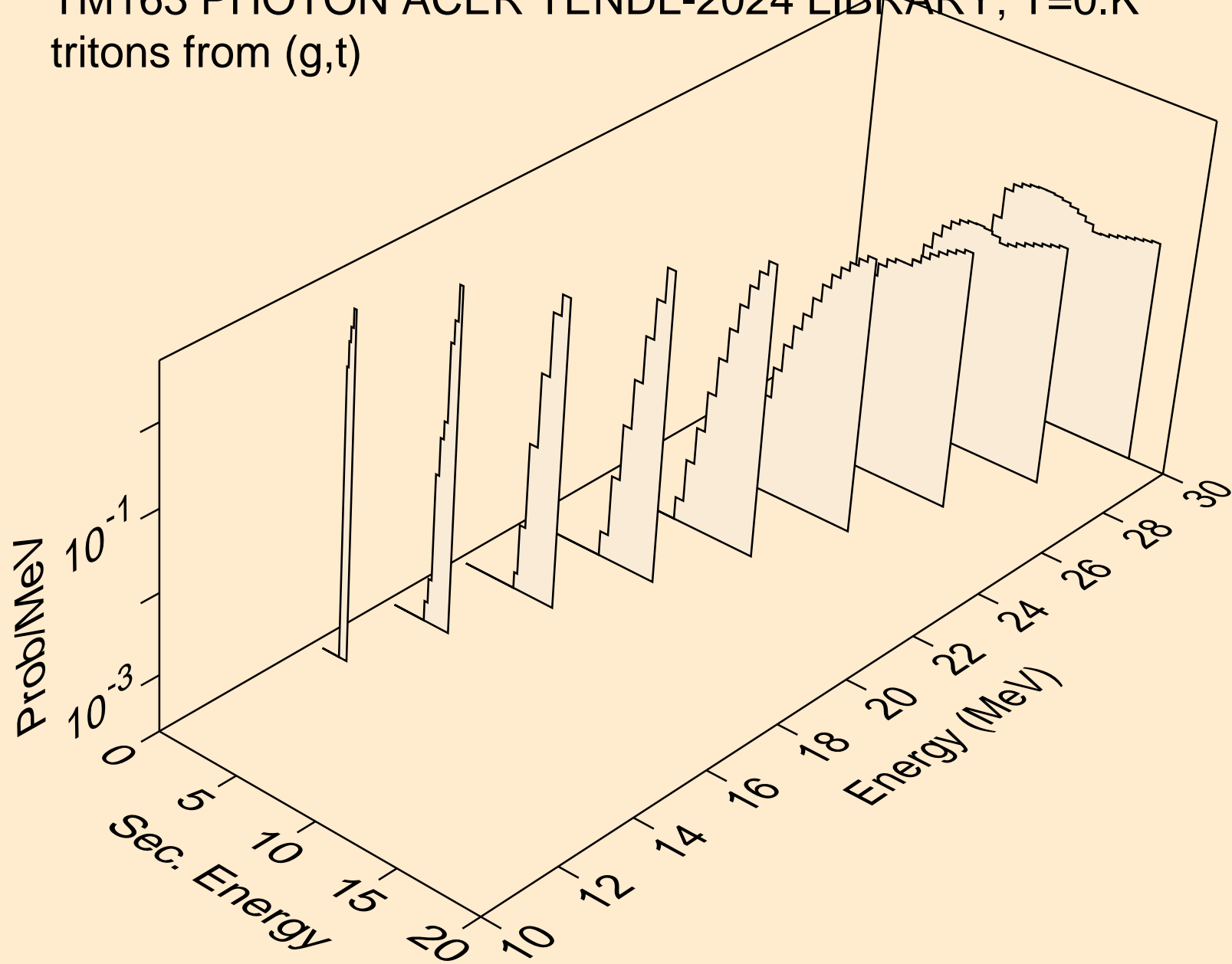

TM163 PHOTON ACER TENDL-2024 LIBRARY; T=0.K  
he3s from (g,x)

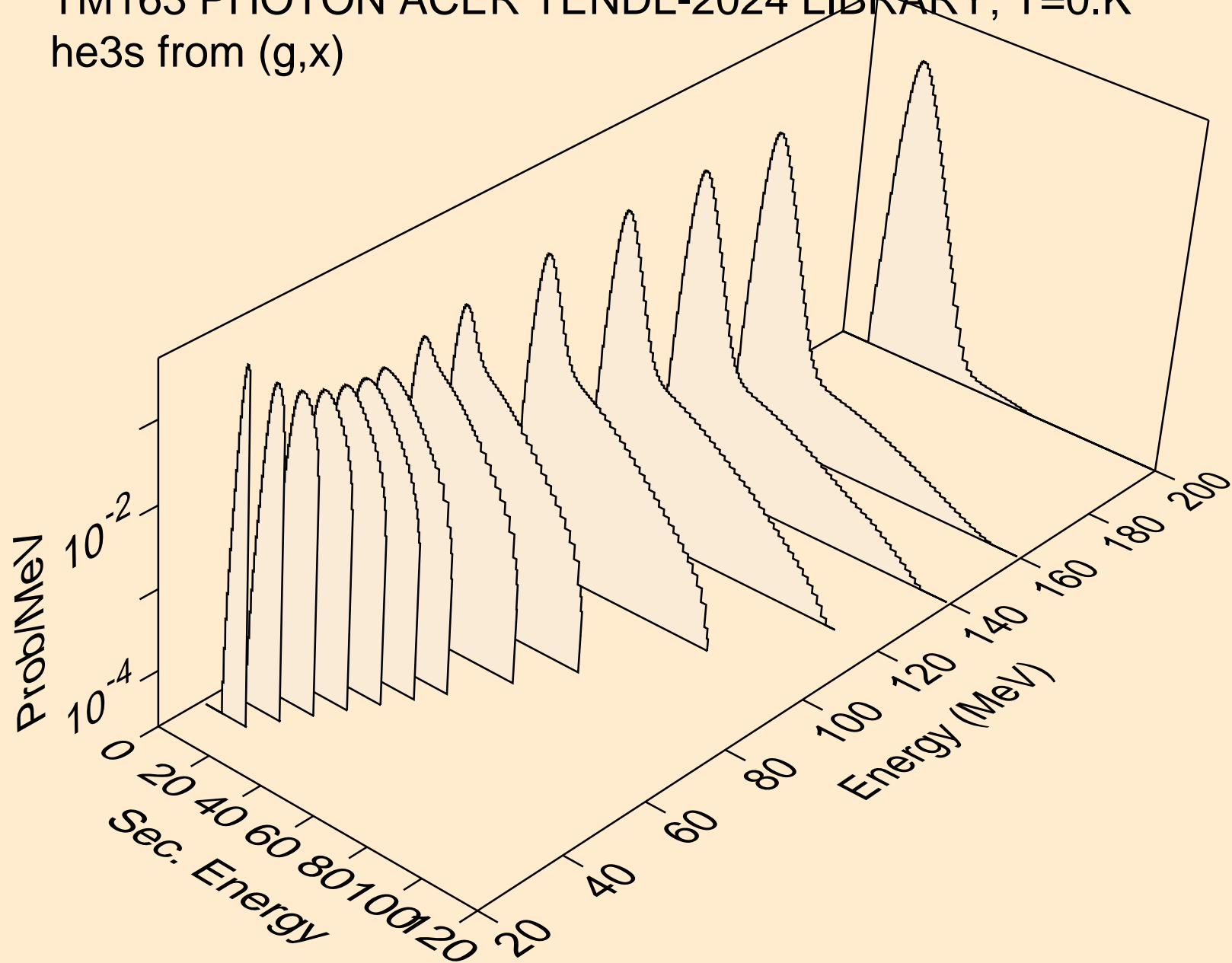

TM163 PHOTON ACER TENDL-2024 LIBRARY; T=0.K  
alphas from (g,x)

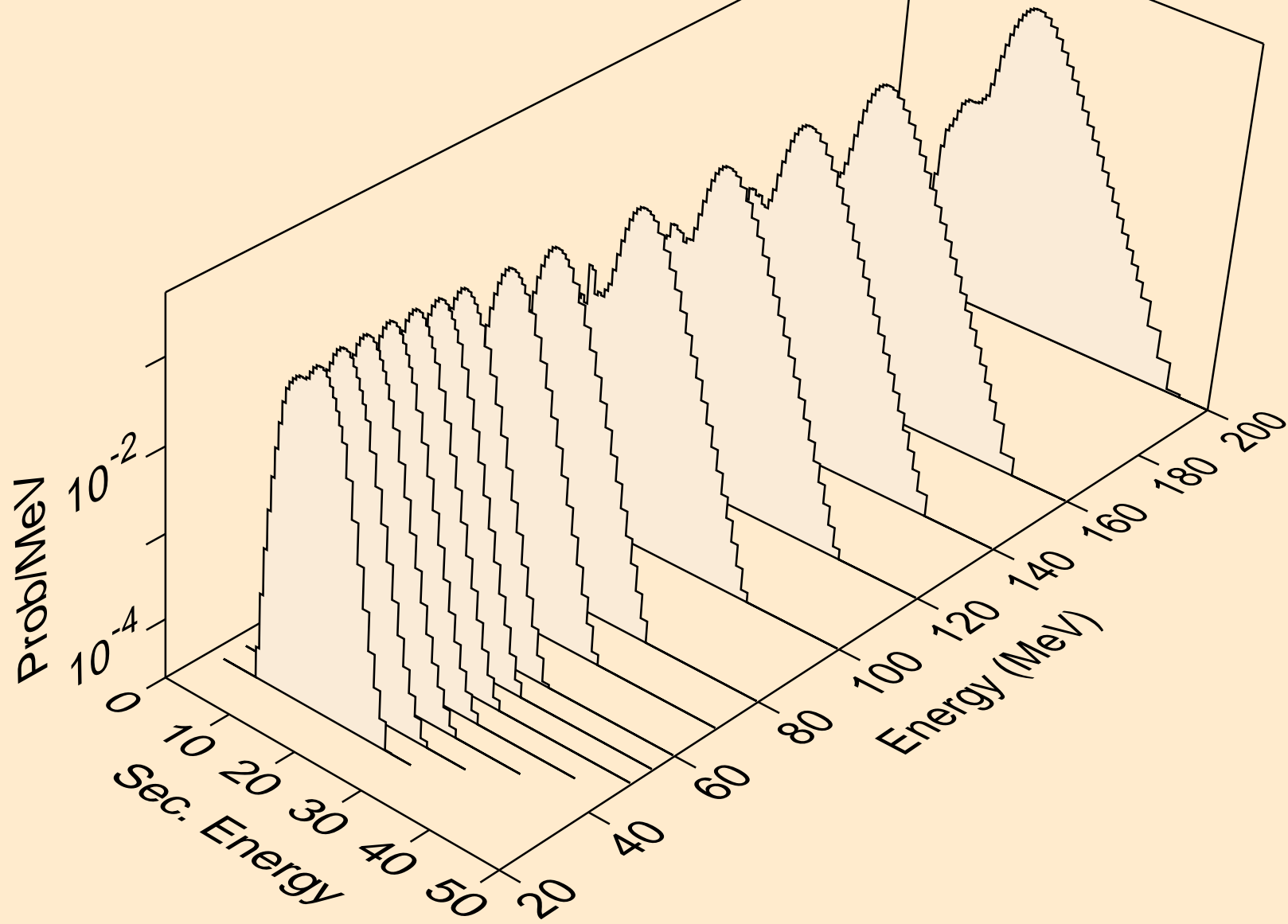

TM163 PHOTON ACER TENDL-2024 LIBRARY; T=0.K  
alphas from (g,n\*)a

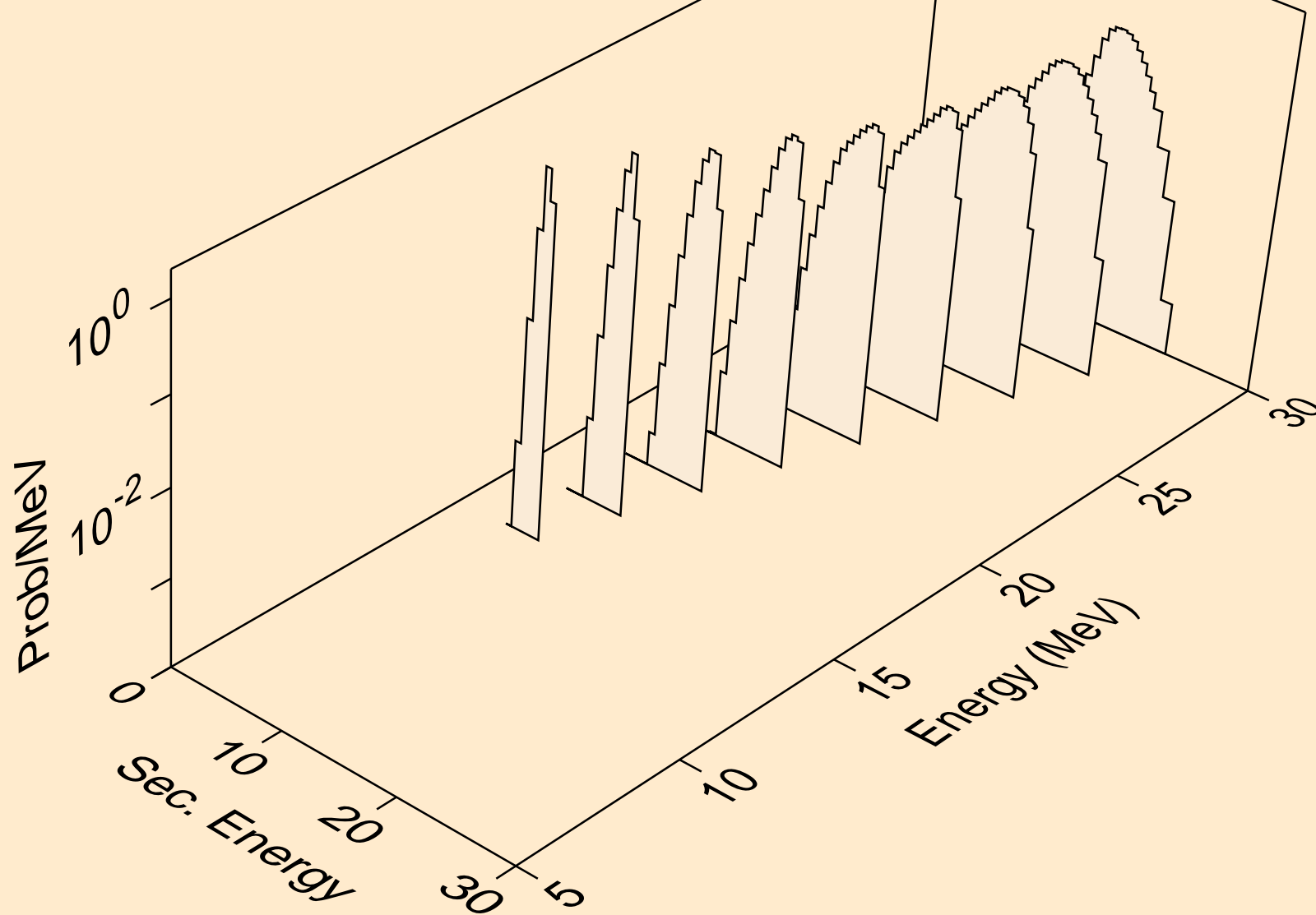

TM163 PHOTON ACER TENDL-2024 LIBRARY; T=0.K  
alphas from (g,2n)a

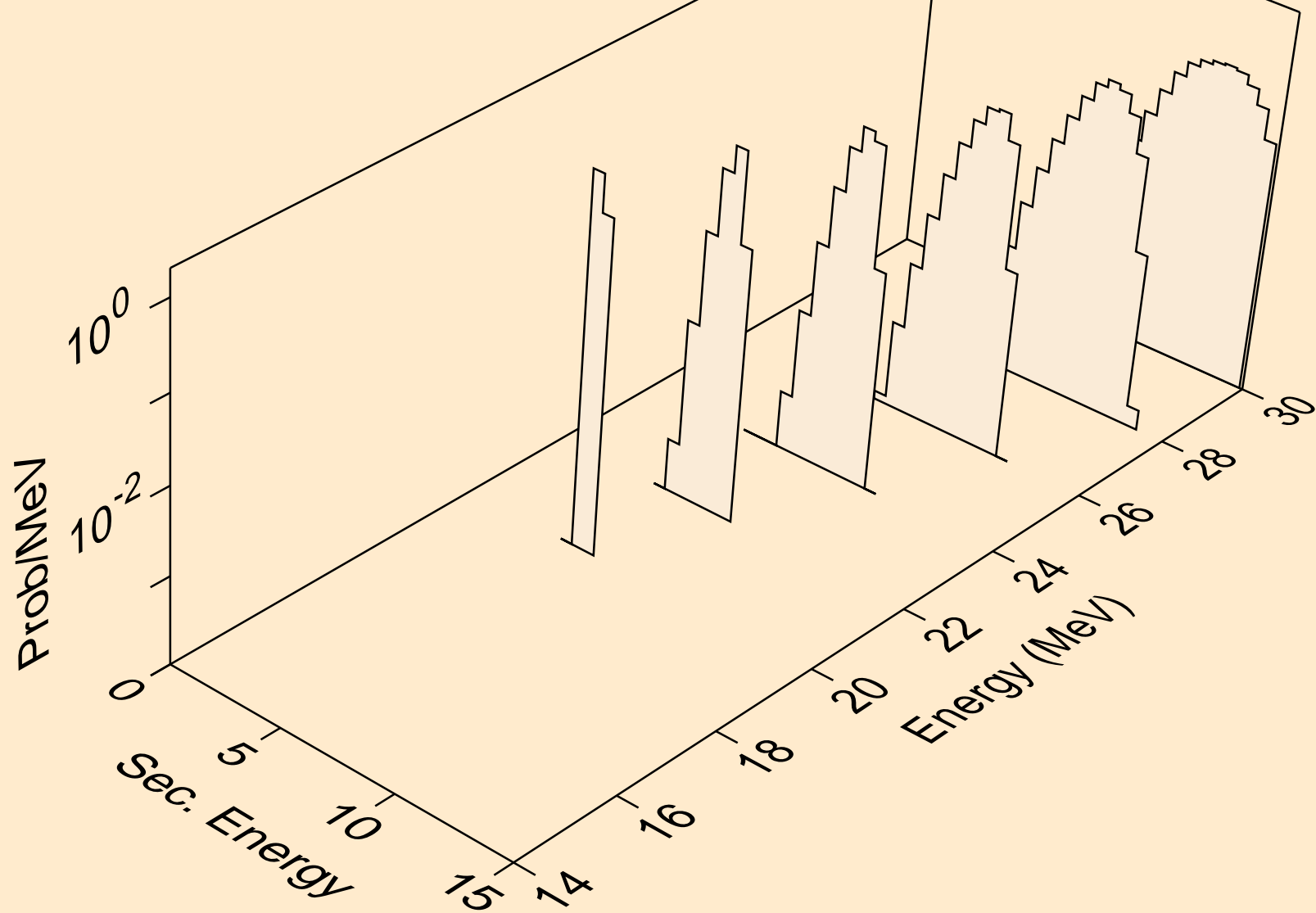

TM163 PHOTON ACER TENDL-2024 LIBRARY; T=0.K  
alphas from (g,npa)

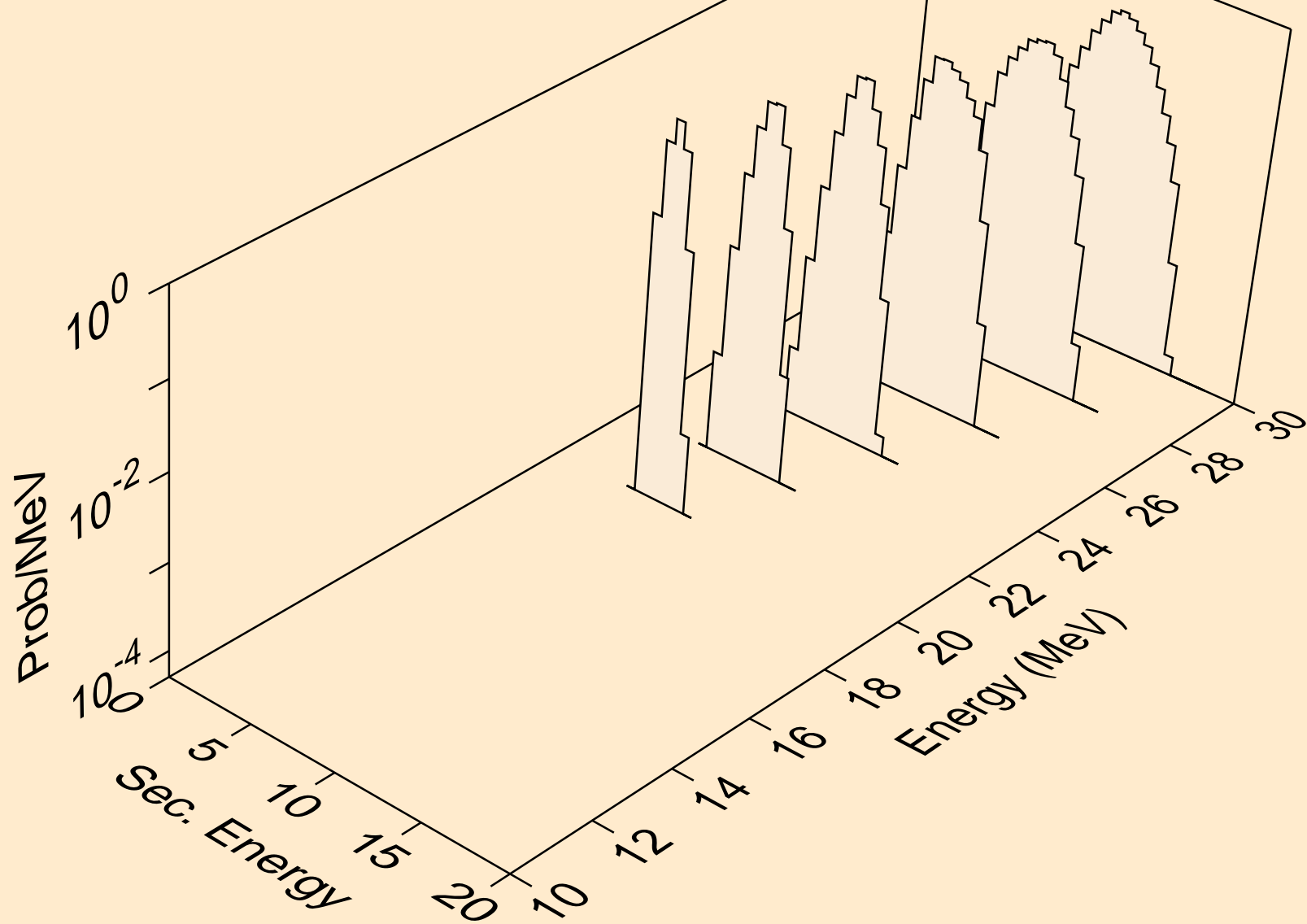

TM163 PHOTON ACER TENDL-2024 LIBRARY; T=0.K  
alphas from (g,a)

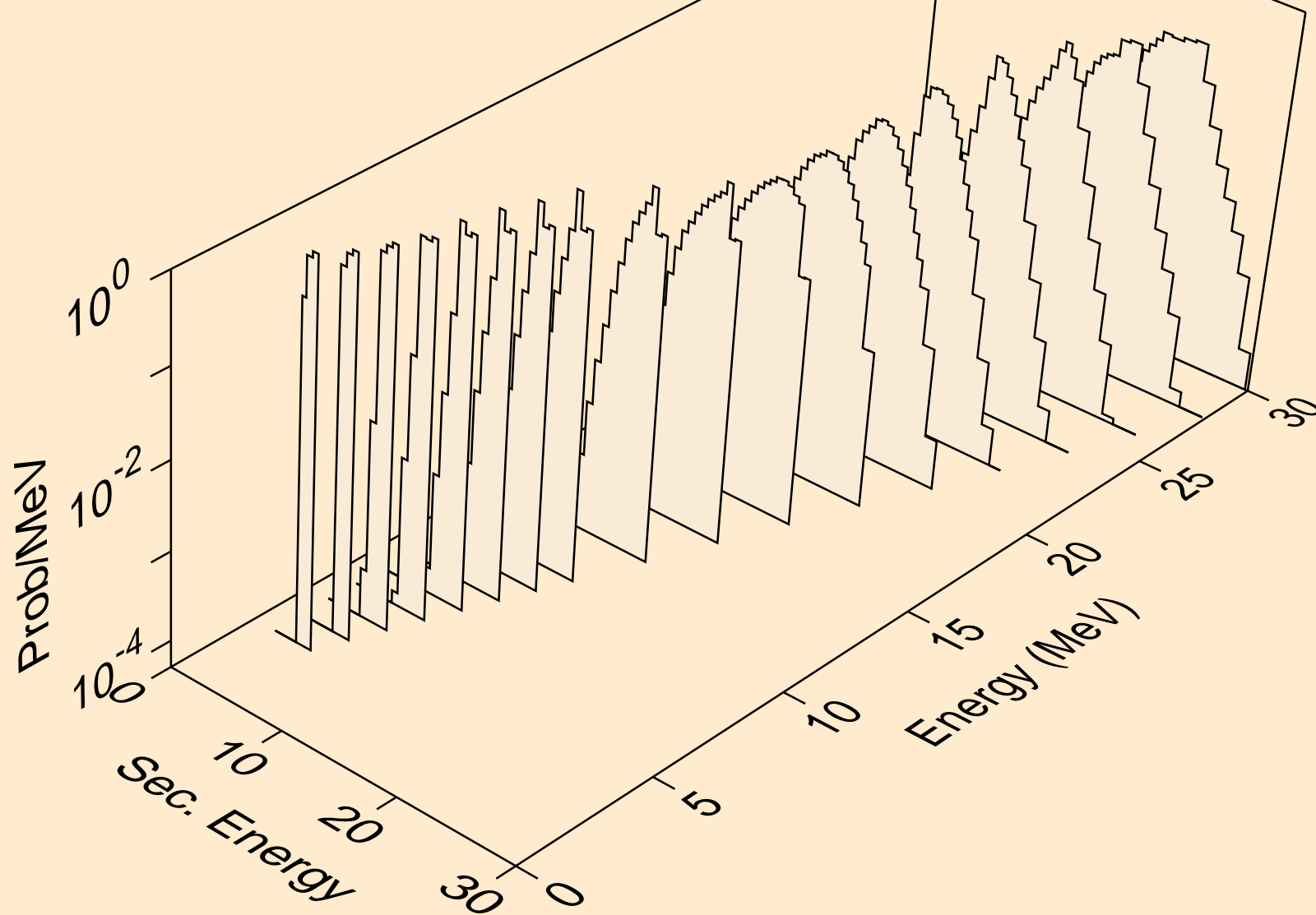

TM163 PHOTON ACER TENDL-2024 LIBRARY; T=0.K  
alphas from (g,pa)

