

KR073 HELION ACER TENDL-2024 LIBRARY; T=0.K  
Principal cross sections

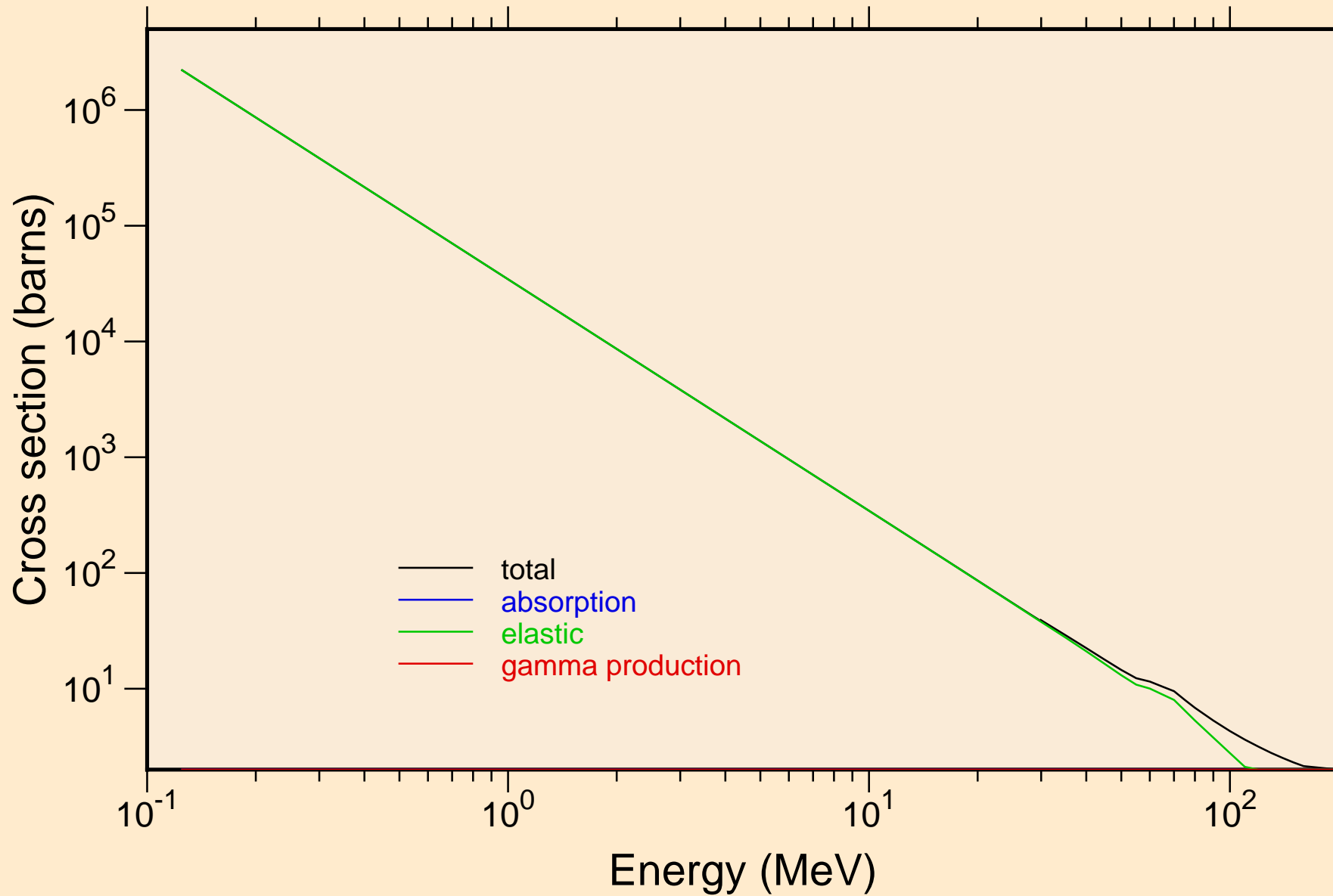

# KR073 HELION ACER TENDL-2024 LIBRARY; T=0.K

## Heating

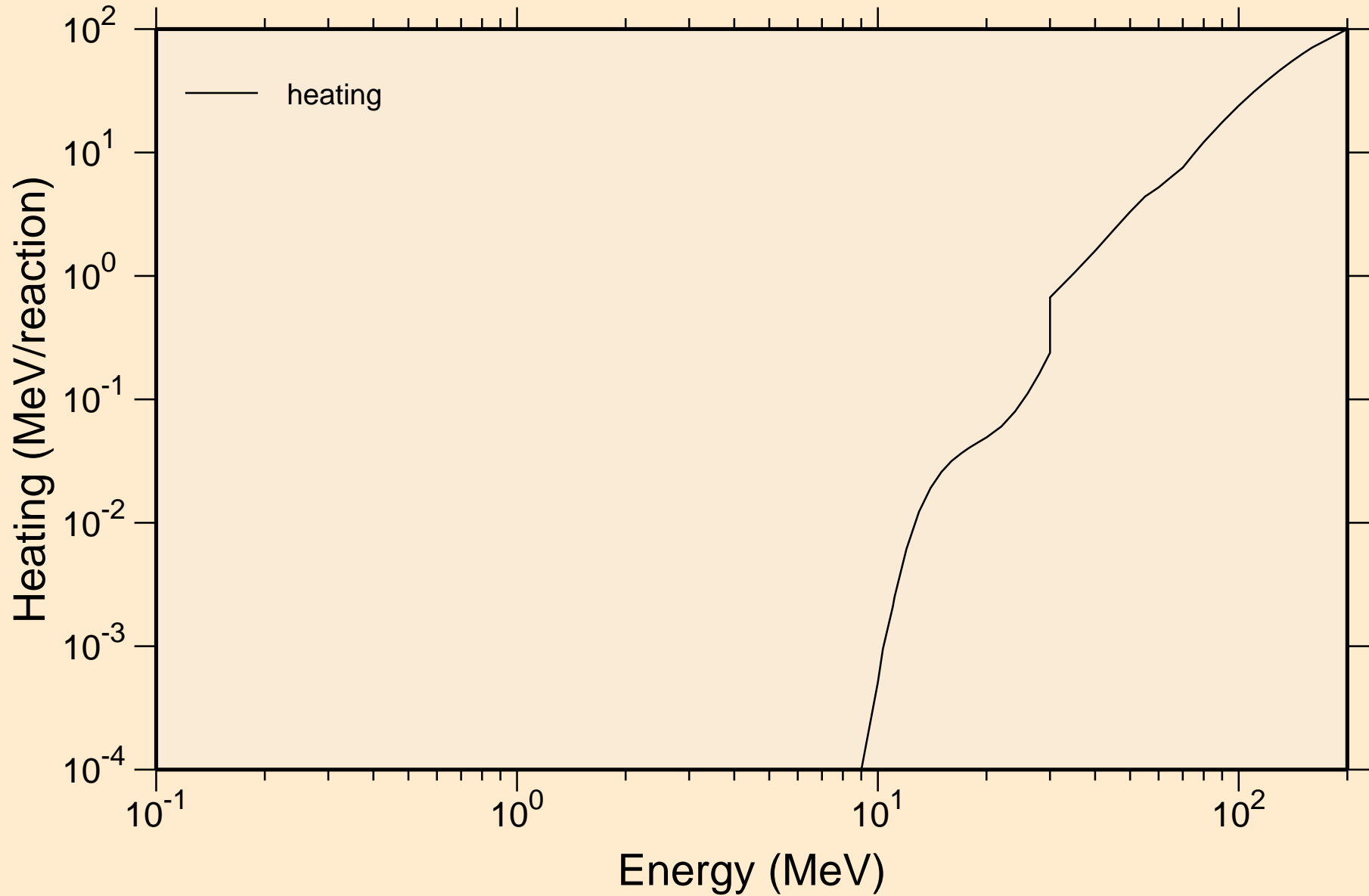

# KR073 HELION ACER TENDL-2024 LIBRARY; T=0.K

## Principal cross sections

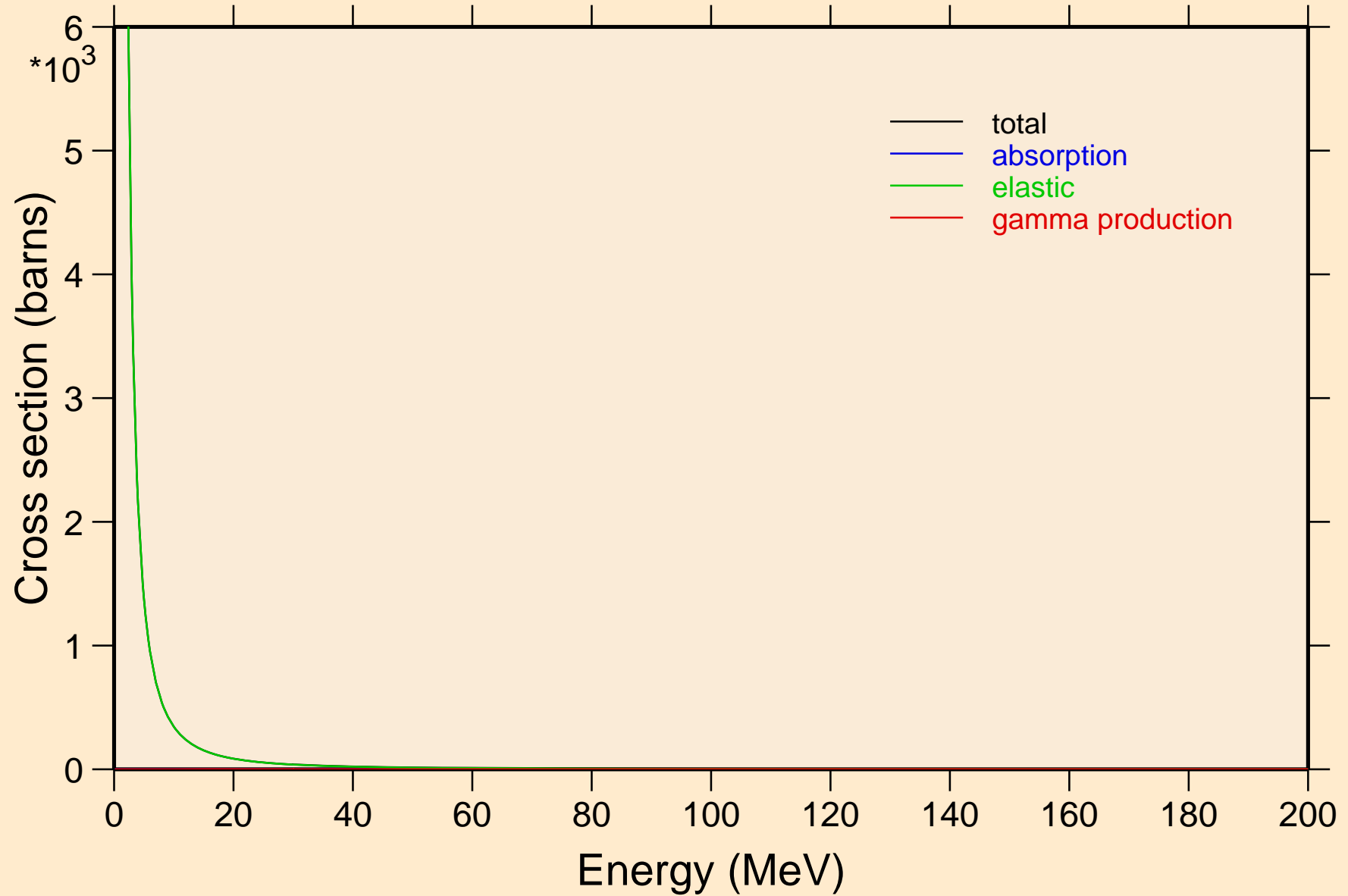

KR073 HELION ACER TENDL-2024 LIBRARY; T=0.K

Heating

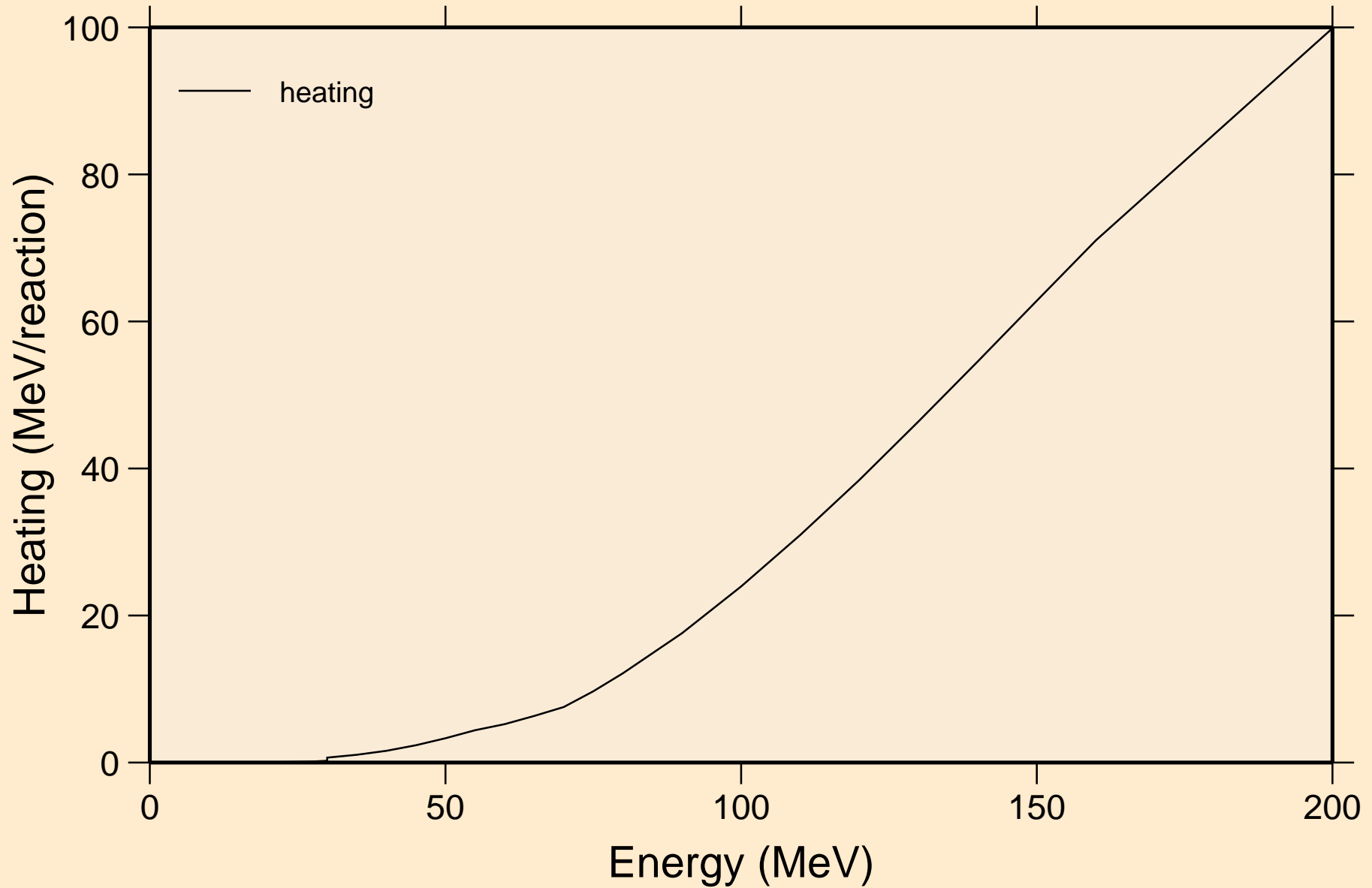

KR073 HELION ACER TENDL-2024 LIBRARY; T=0.K  
Threshold reactions

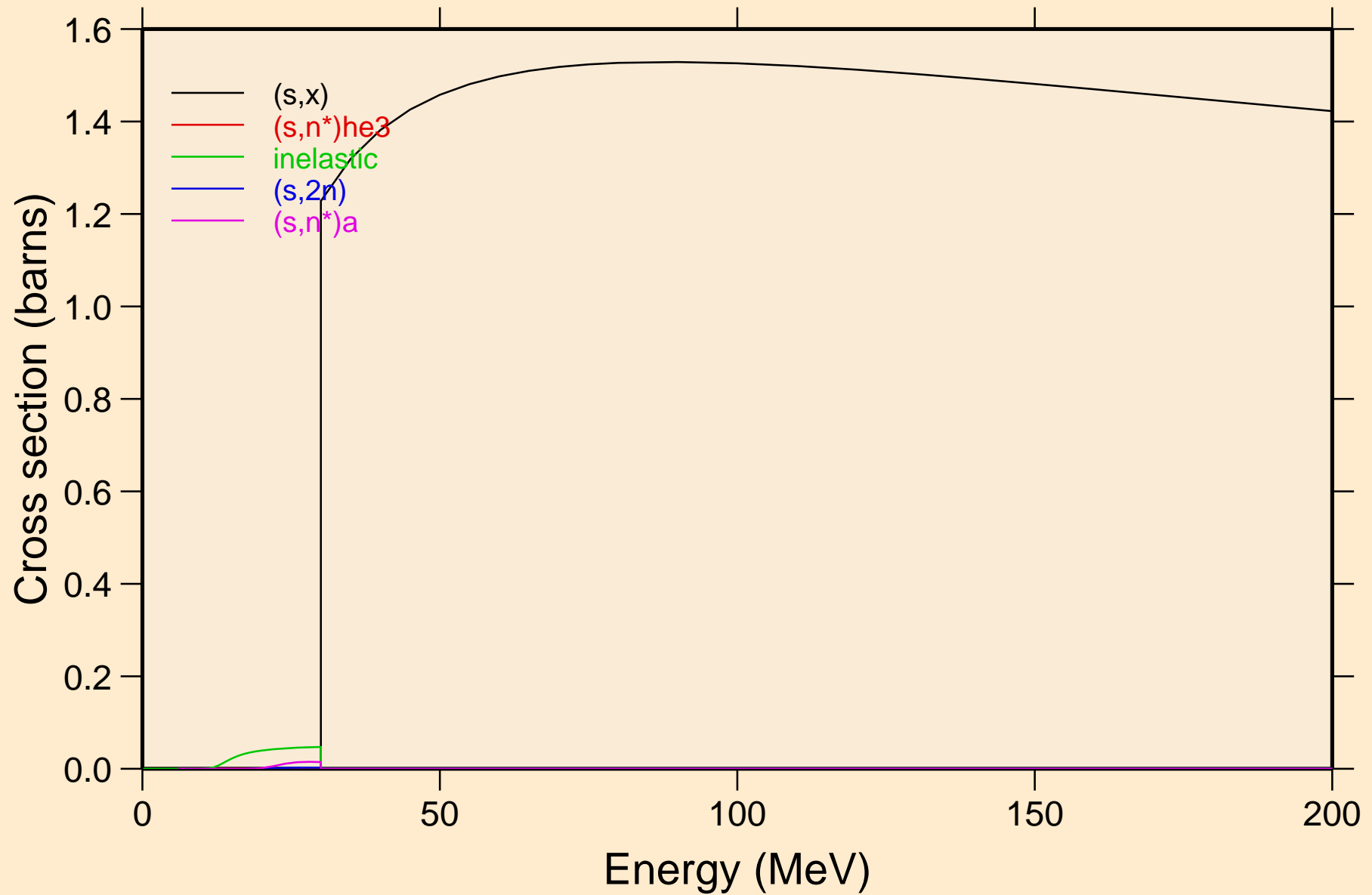

KR073 HELION ACER TENDL-2024 LIBRARY; T=0.K  
Threshold reactions

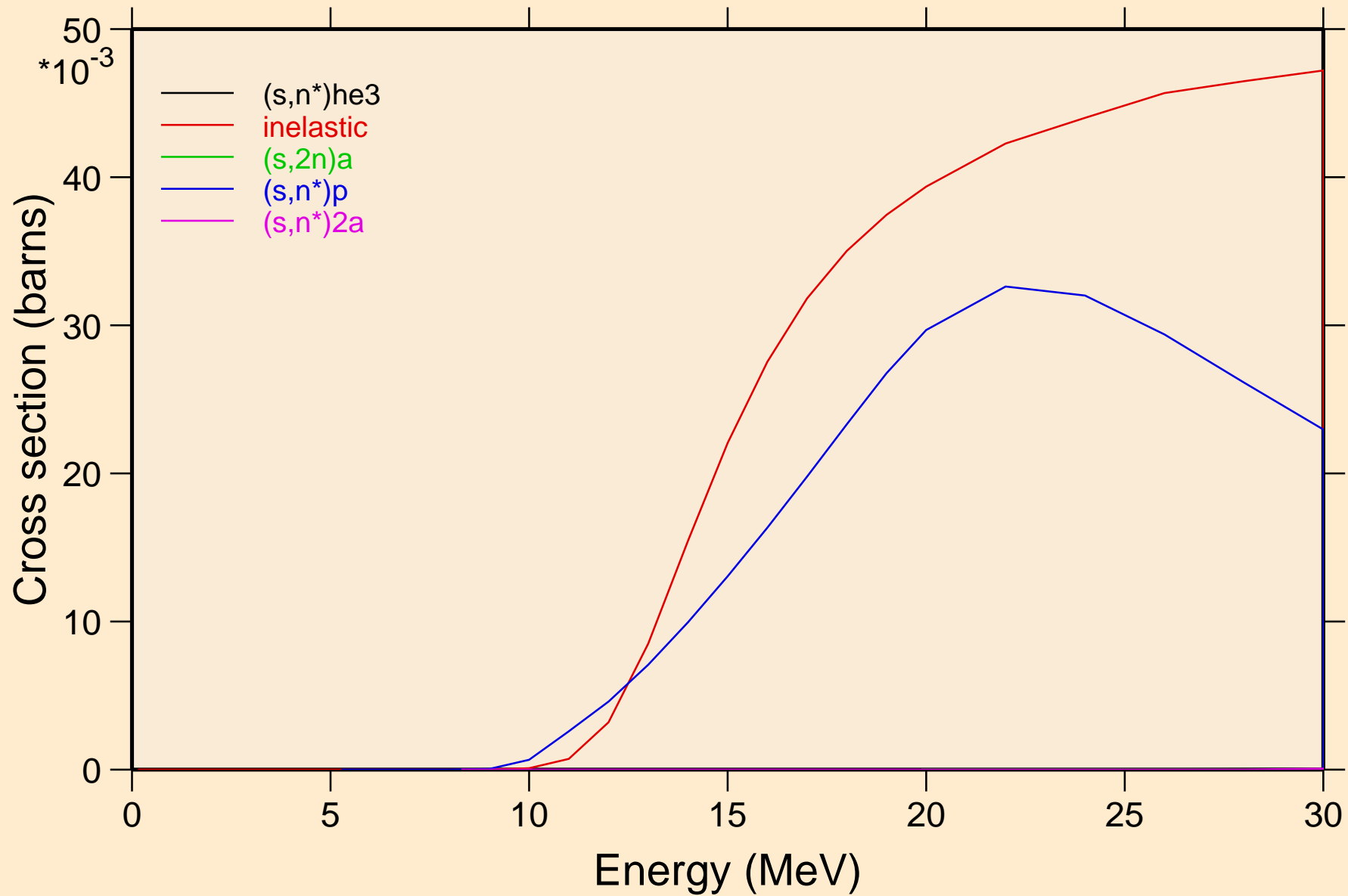

KR073 HELION ACER TENDL-2024 LIBRARY; T=0.K  
Threshold reactions

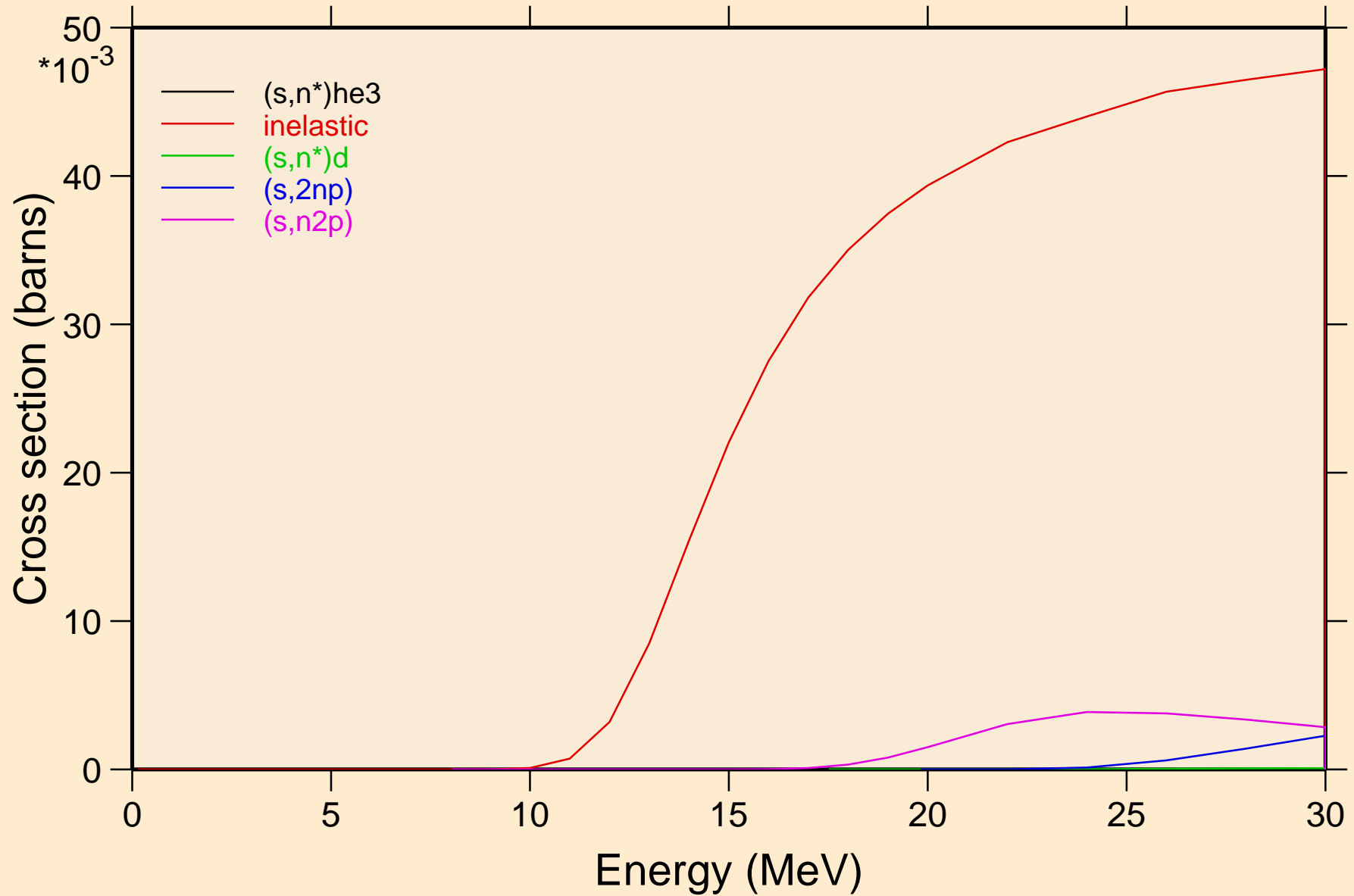

# KR073 HELION ACER TENDL-2024 LIBRARY; T=0.K

## Threshold reactions

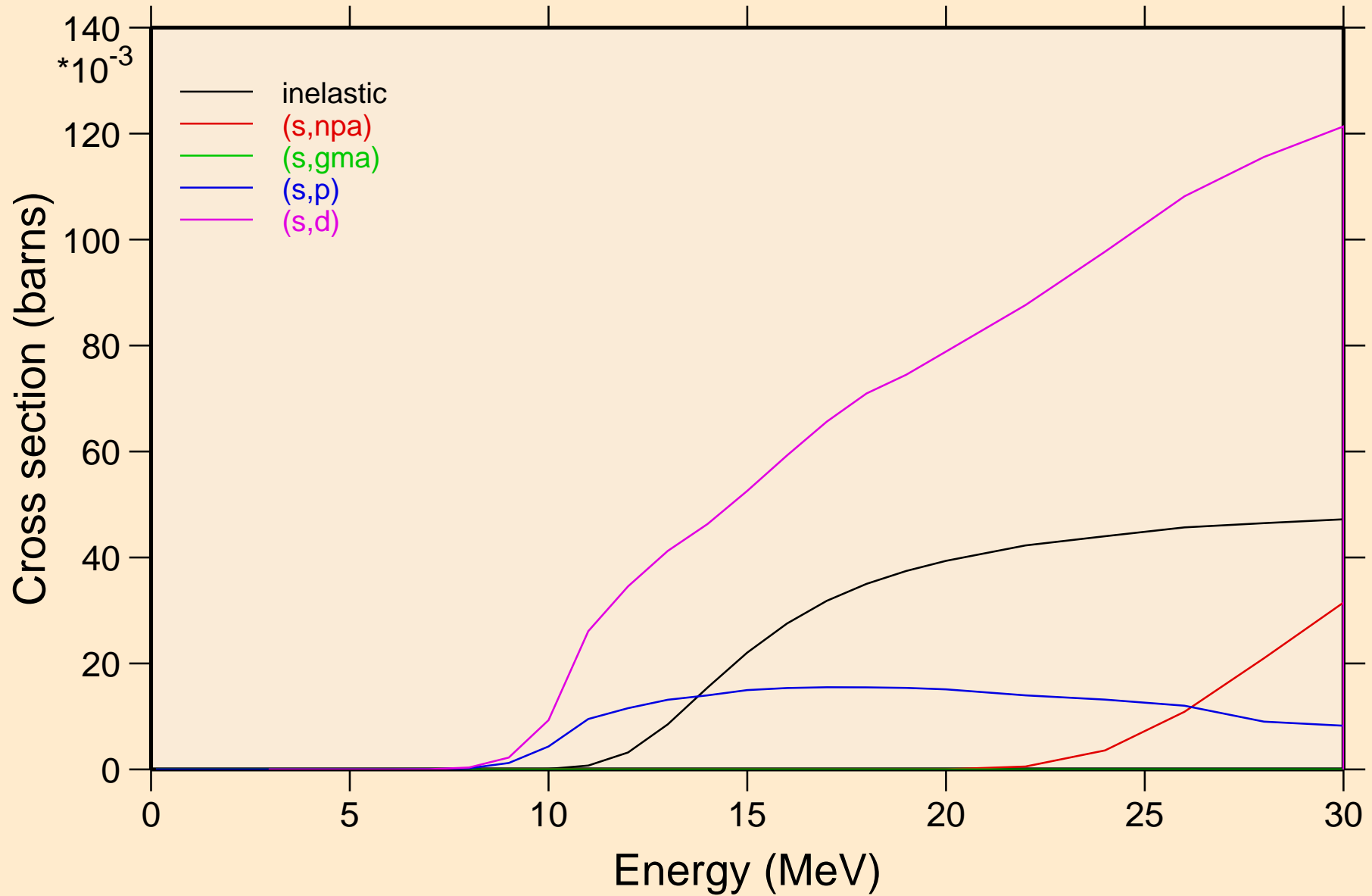

# KR073 HELION ACER TENDL-2024 LIBRARY; T=0.K

## Threshold reactions

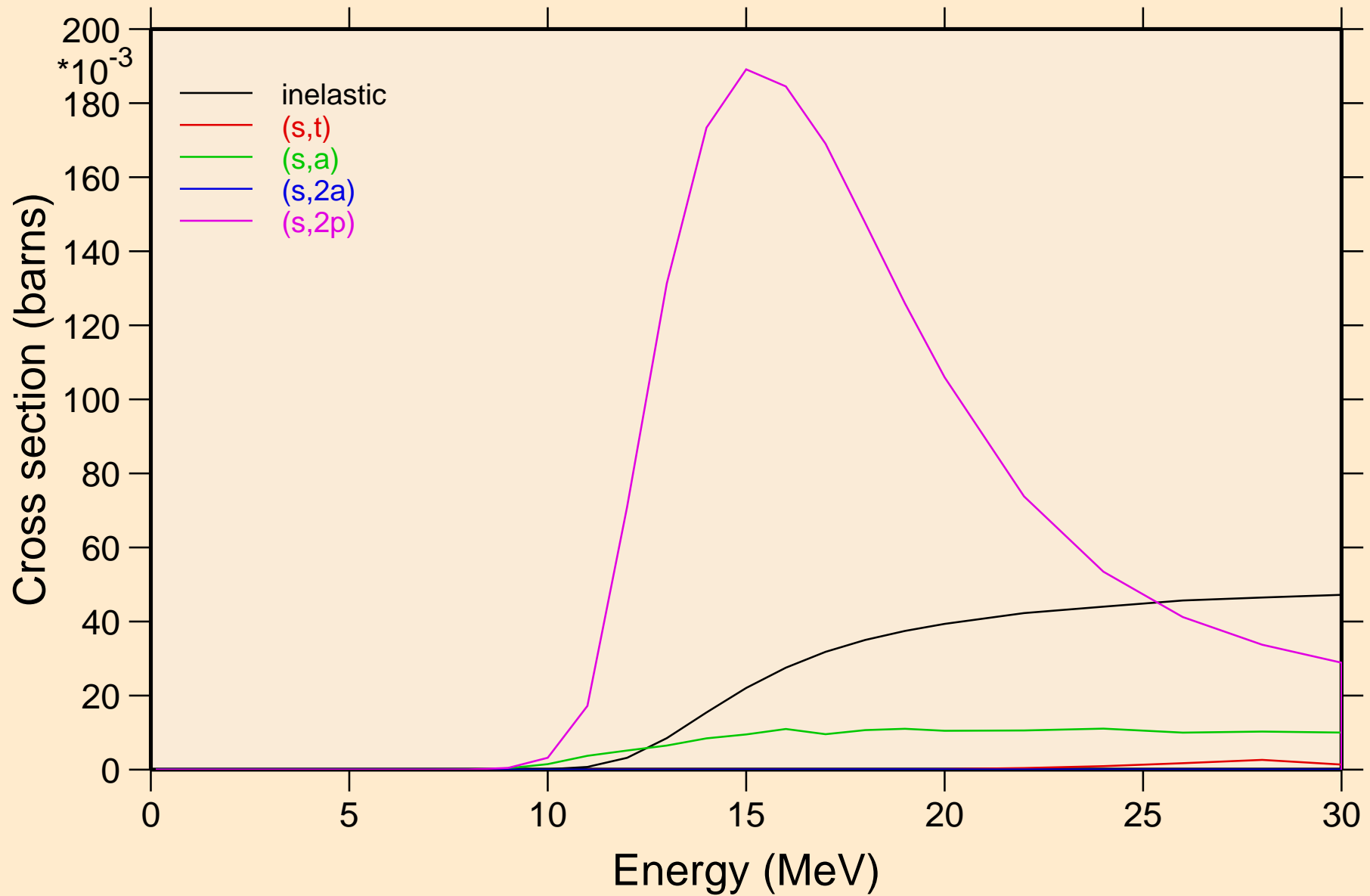

# KR073 HELION ACER TENDL-2024 LIBRARY; T=0.K

## Threshold reactions

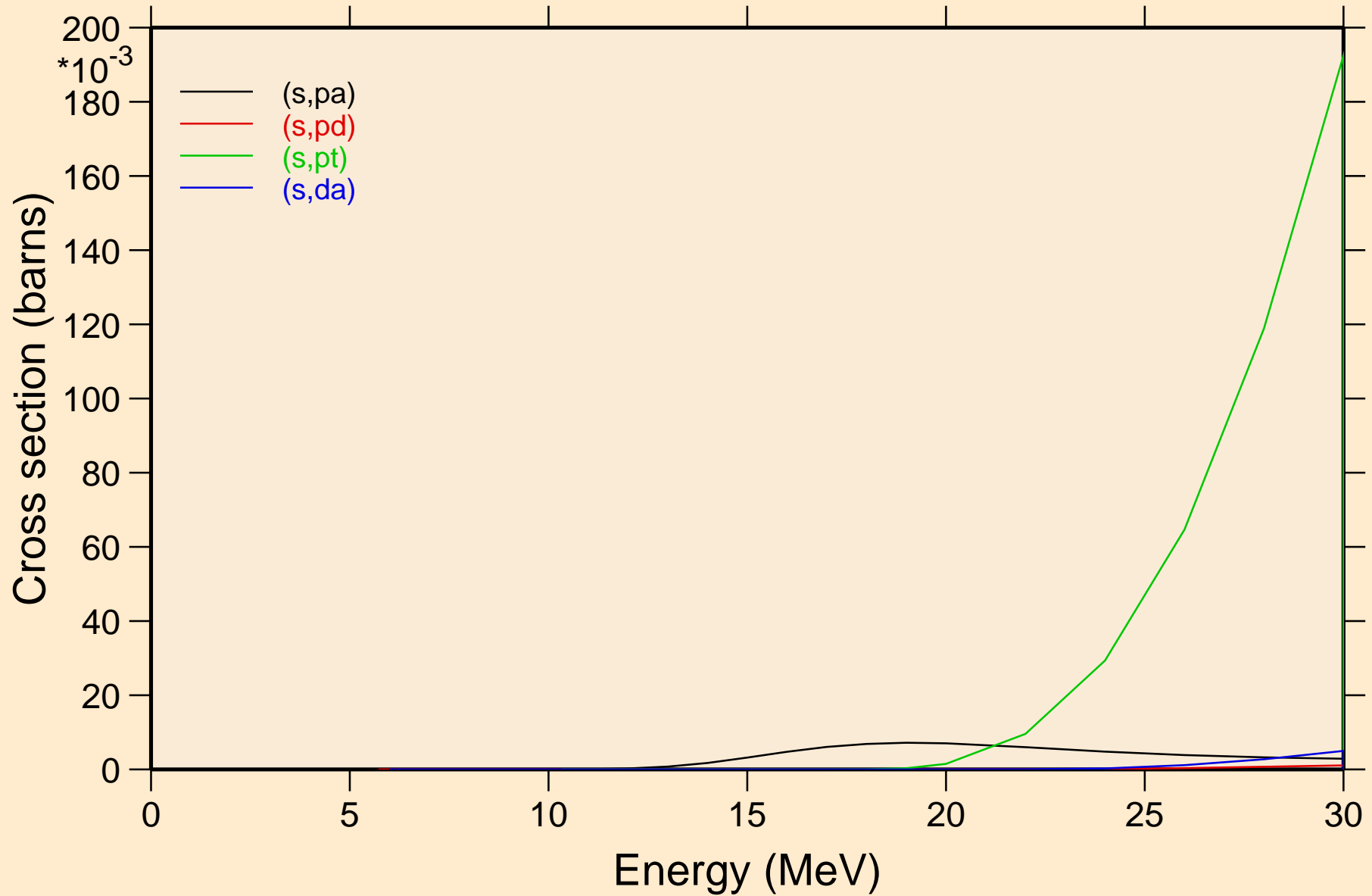

KR073 HELION ACER TENDL-2024 LIBRARY; T=0.K  
angular distribution for elastic

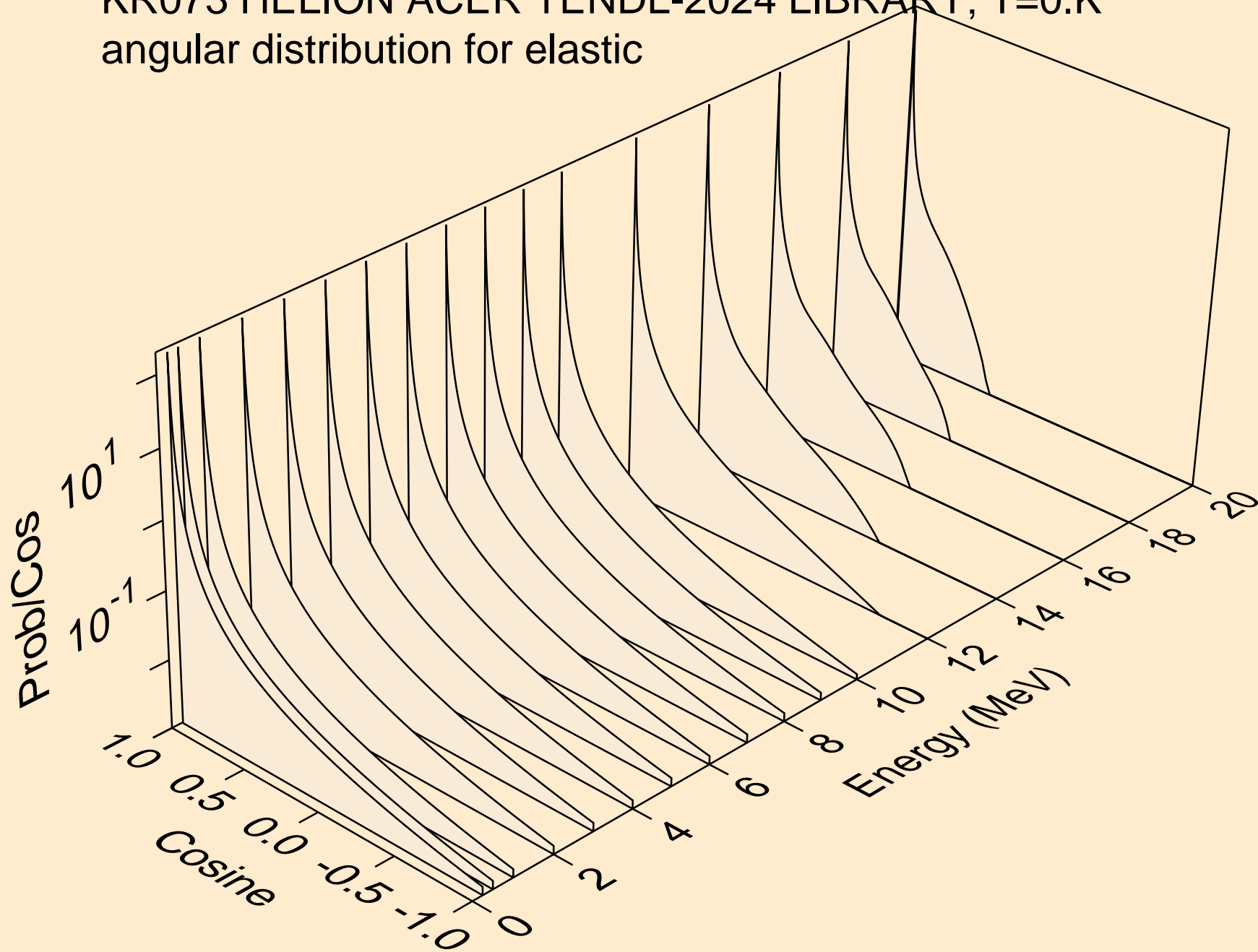

KR073 HELION ACER TENDL-2024 LIBRARY; T=0.K  
angular distribution for elastic

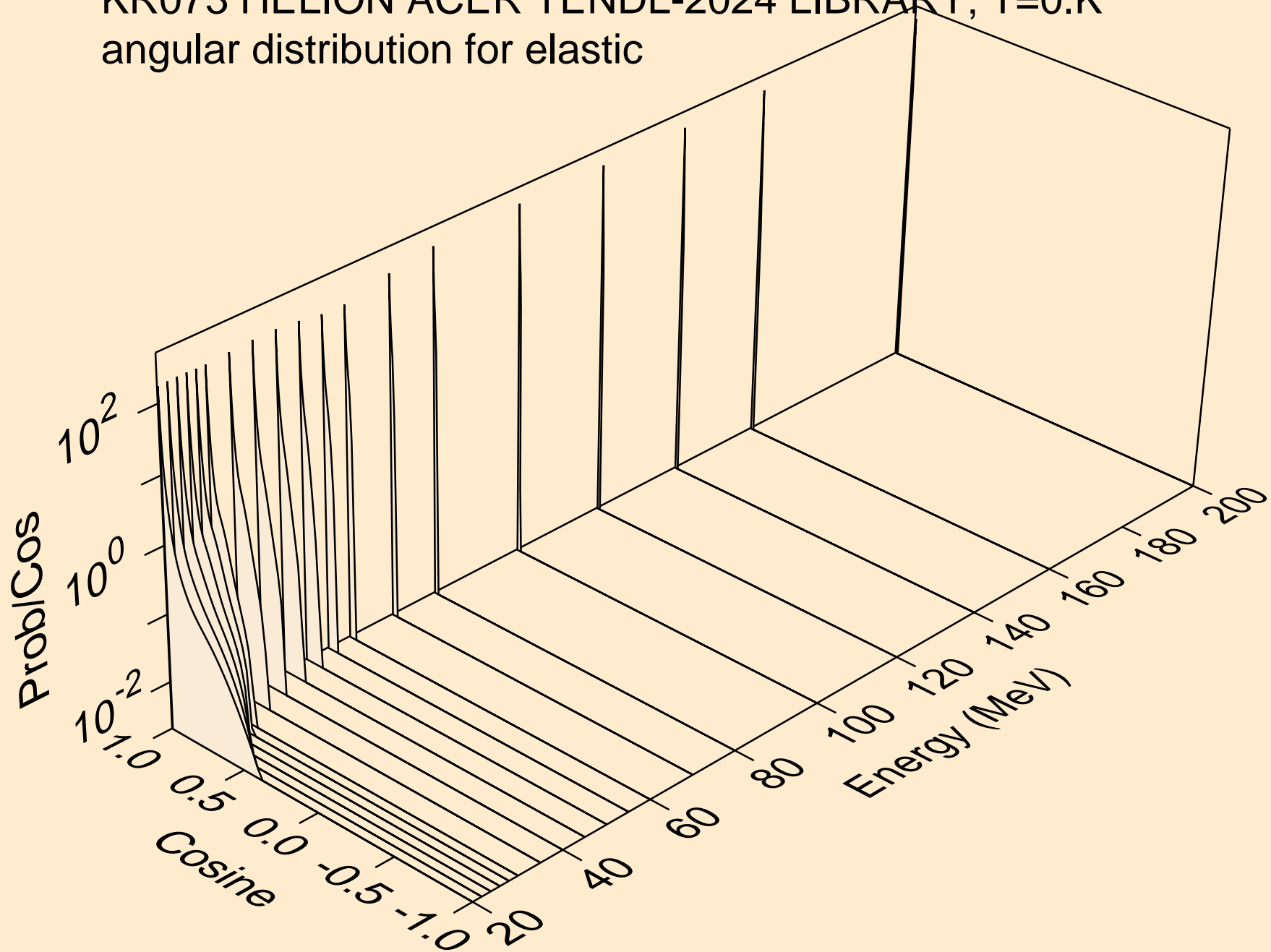

KR073 HELION ACER TENDL-2024 LIBRARY; T=0.K  
He-3 emission for (s,x)

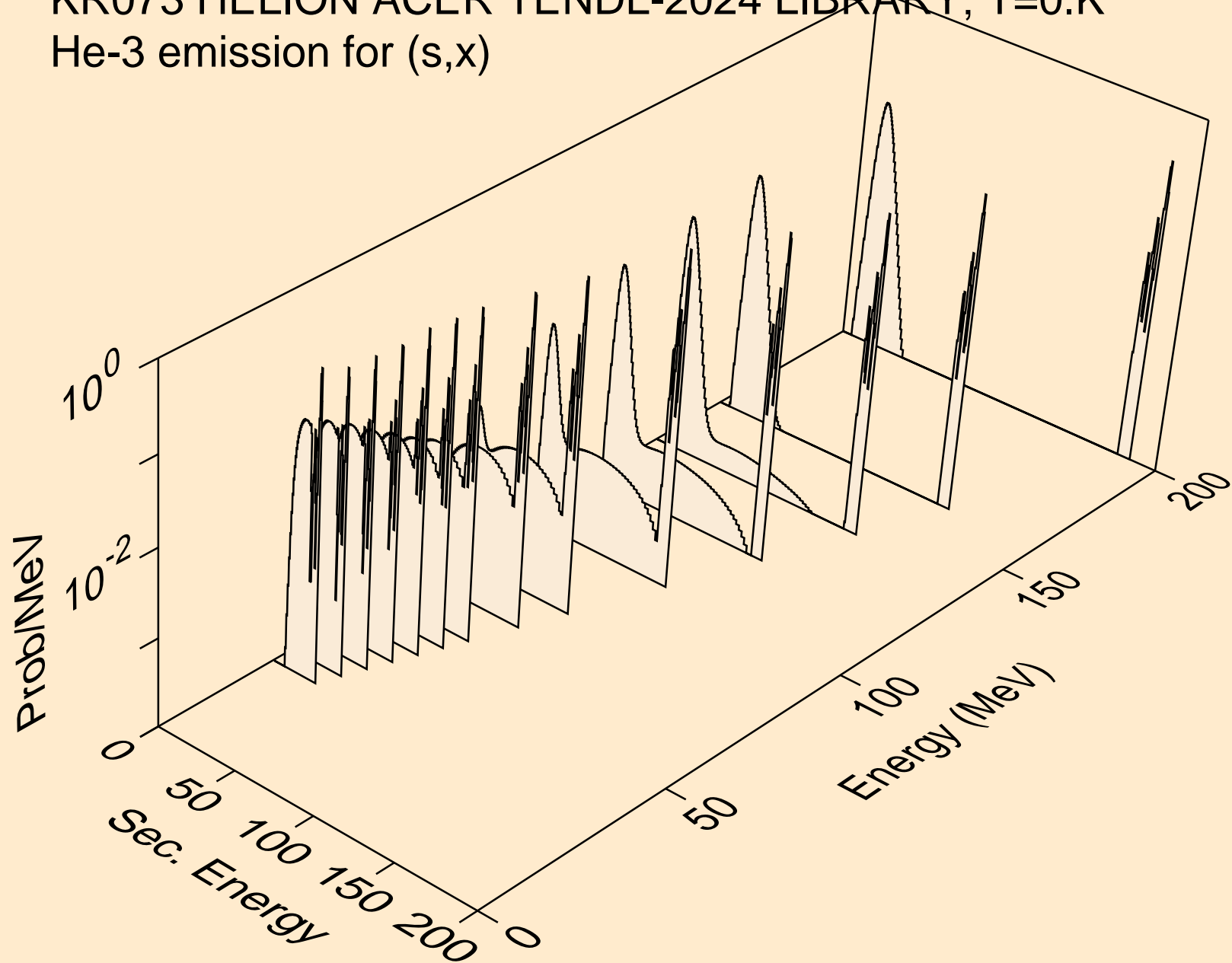

KR073 HELION ACER TENDL-2024 LIBRARY; T=0.K  
He-3 emission for (s,n\*)he3

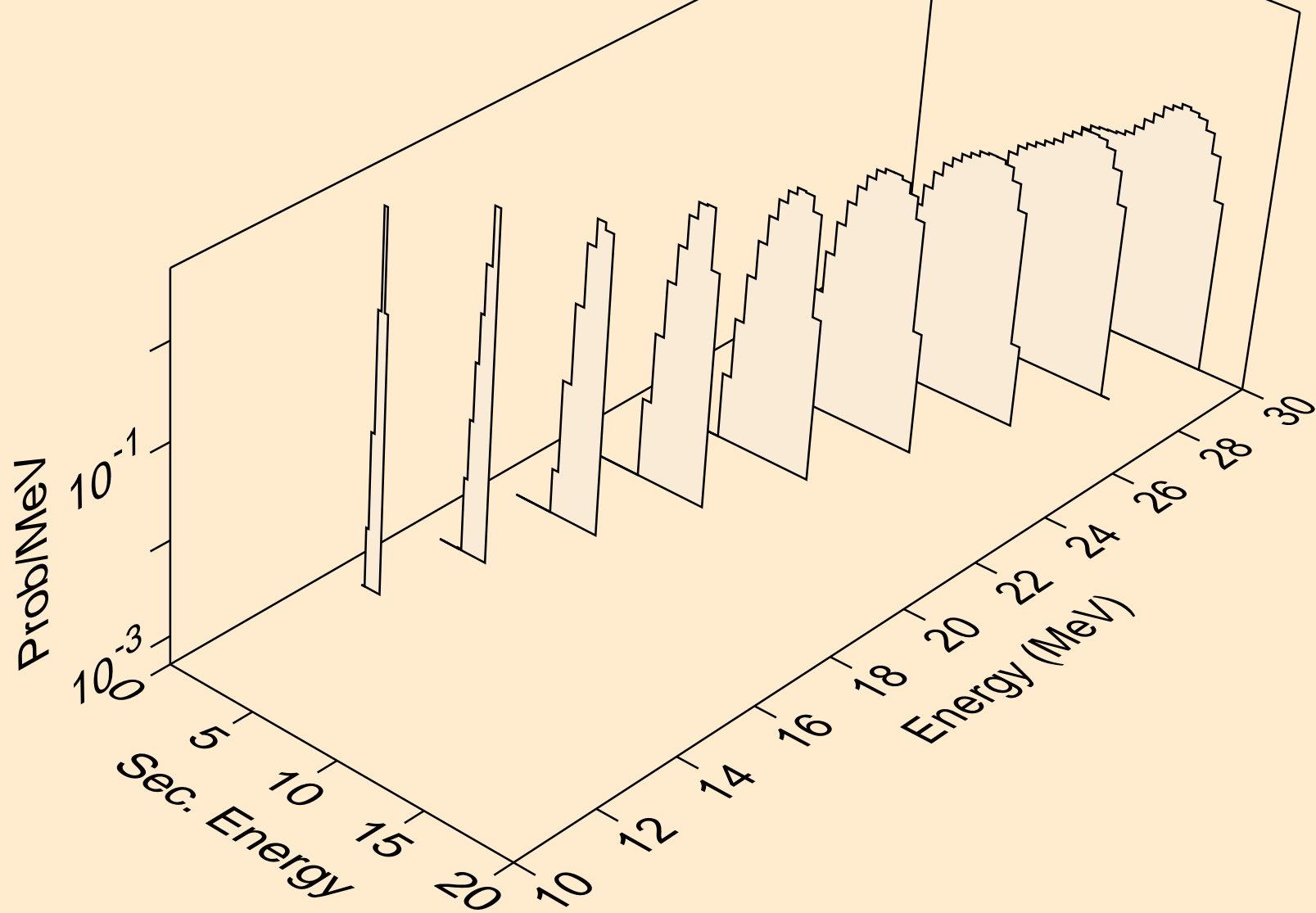

KR073 HELION ACER TENDL-2024 LIBRARY; T=0.K  
He-3 emission for inelastic

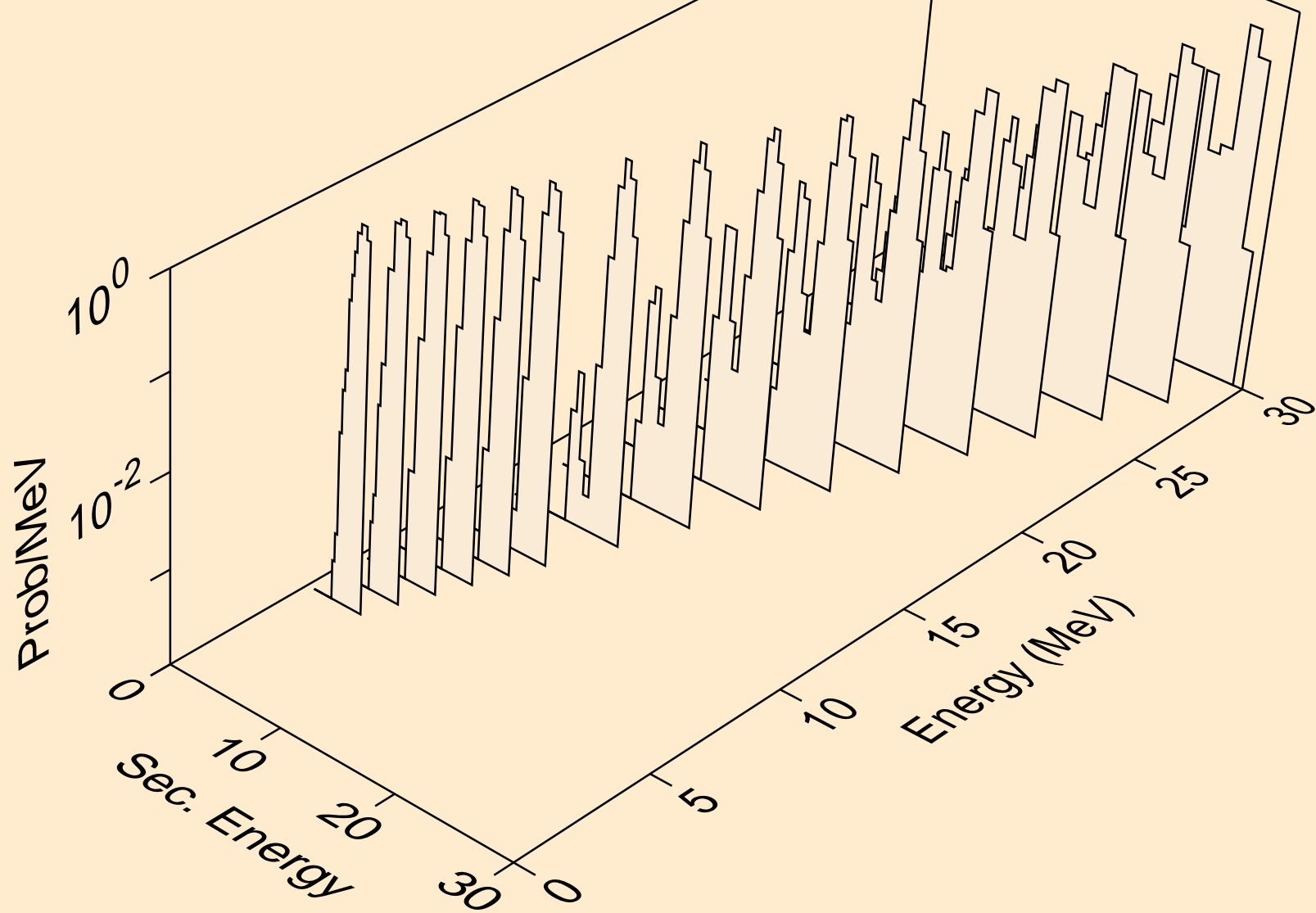

KR073 HELION ACER TENDL-2024 LIBRARY; T=0.K  
Photon emission for (z,n)

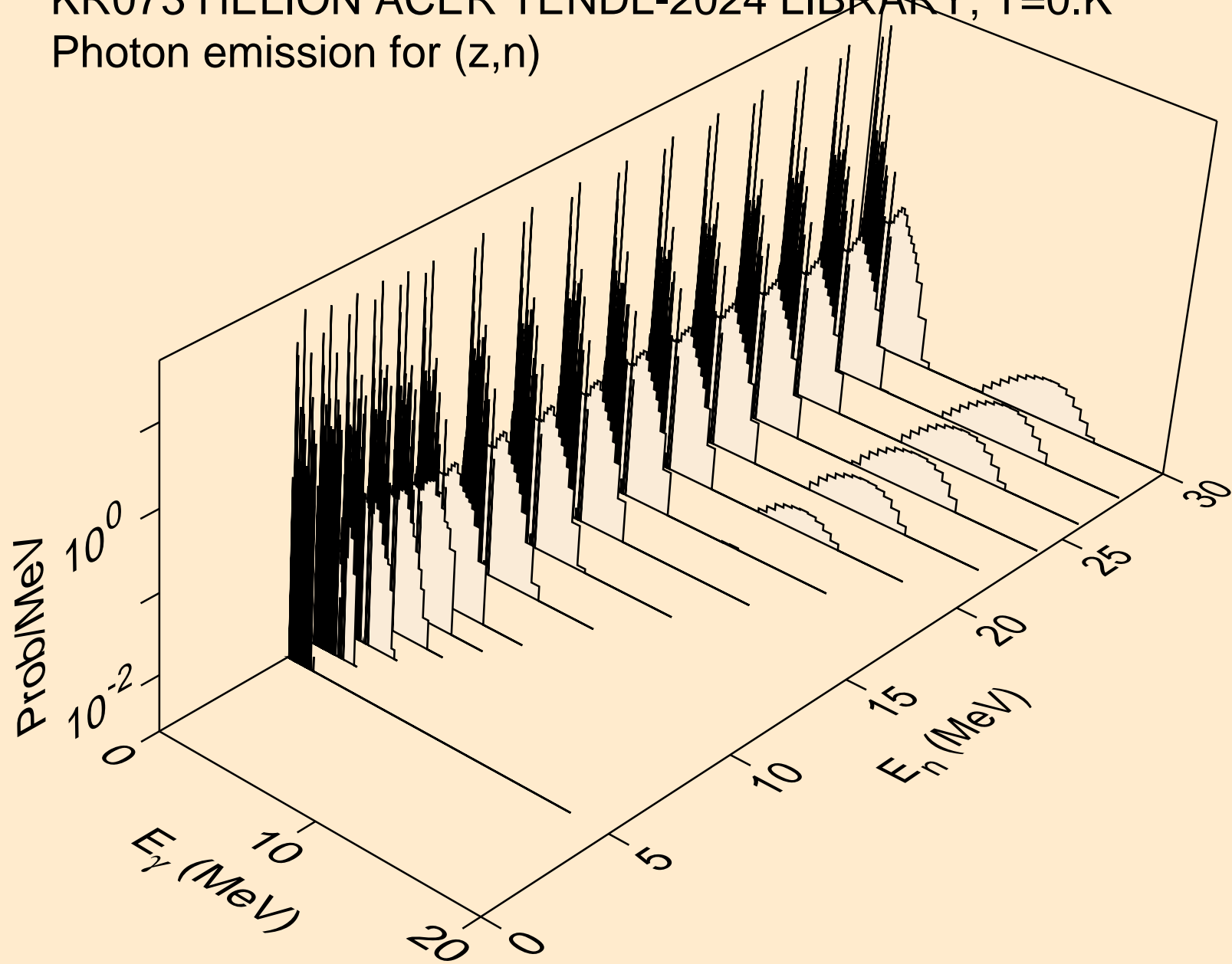

KR073 HELION ACER TENDL-2024 LIBRARY; T=0.K  
Photon emission for (z,x)

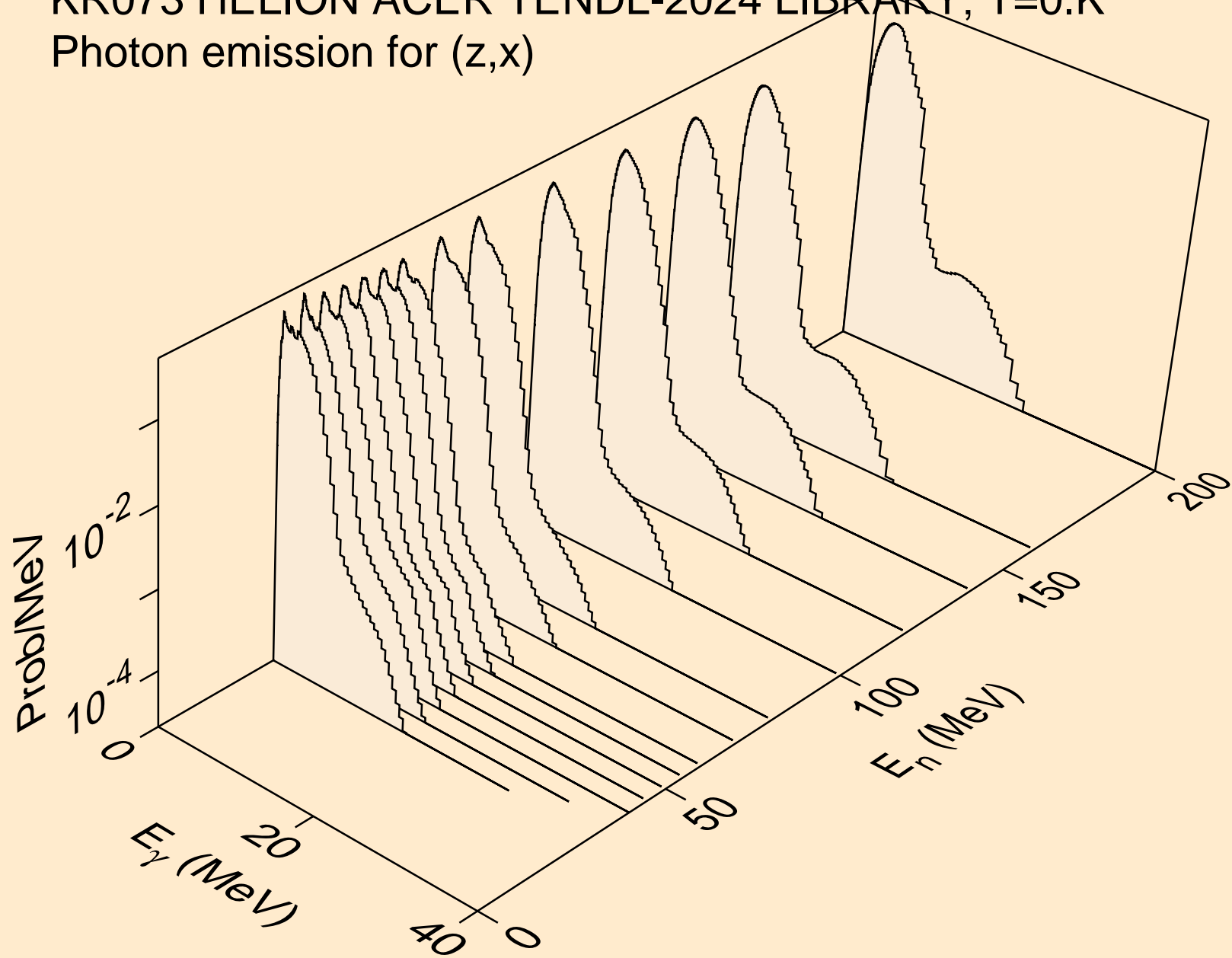

KR073 HELION ACER TENDL-2024 LIBRARY; T=0.K  
Photon emission for (n,2n)

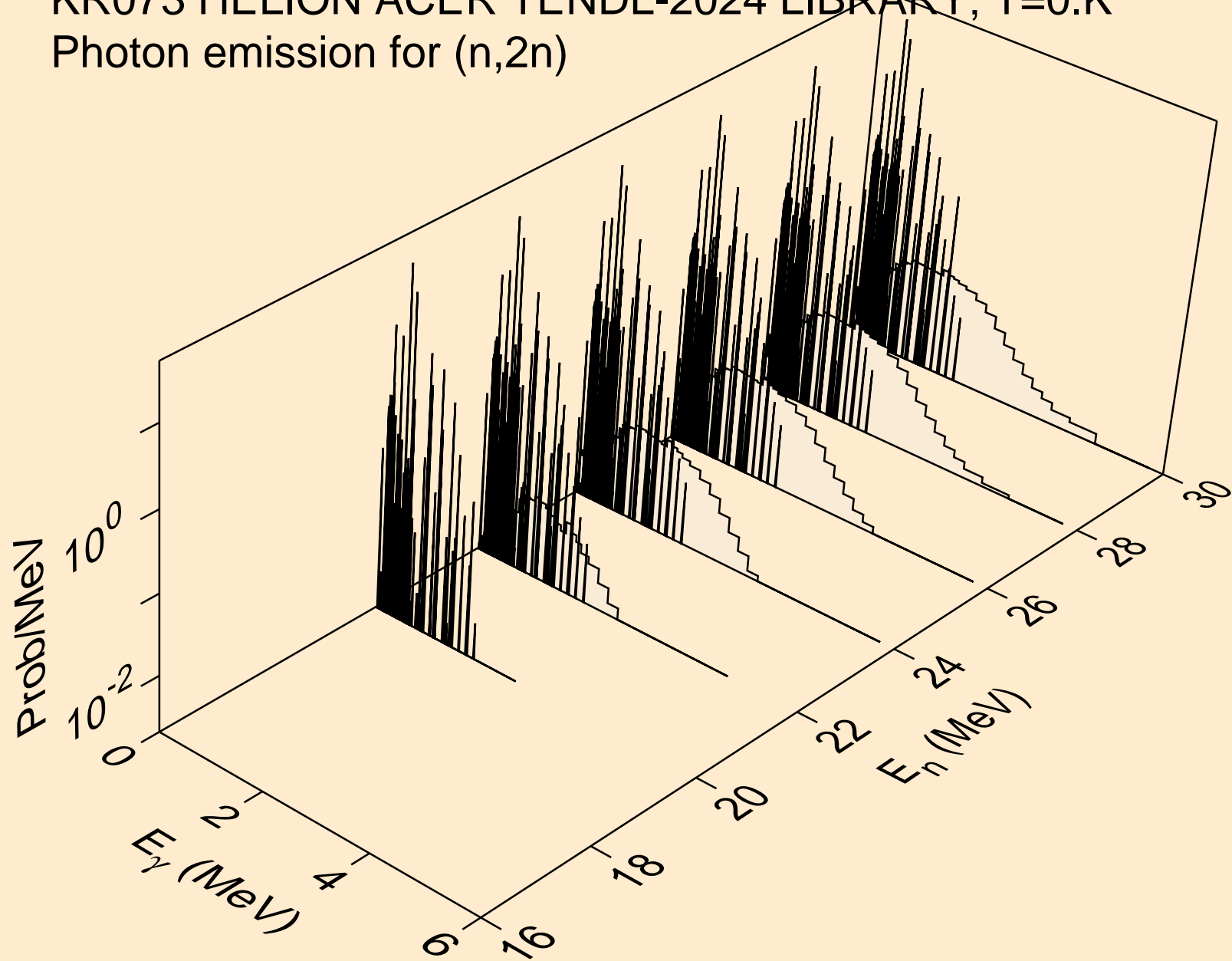

KR073 HELION ACER TENDL-2024 LIBRARY; T=0.K  
Photon emission for (n,n\*)a

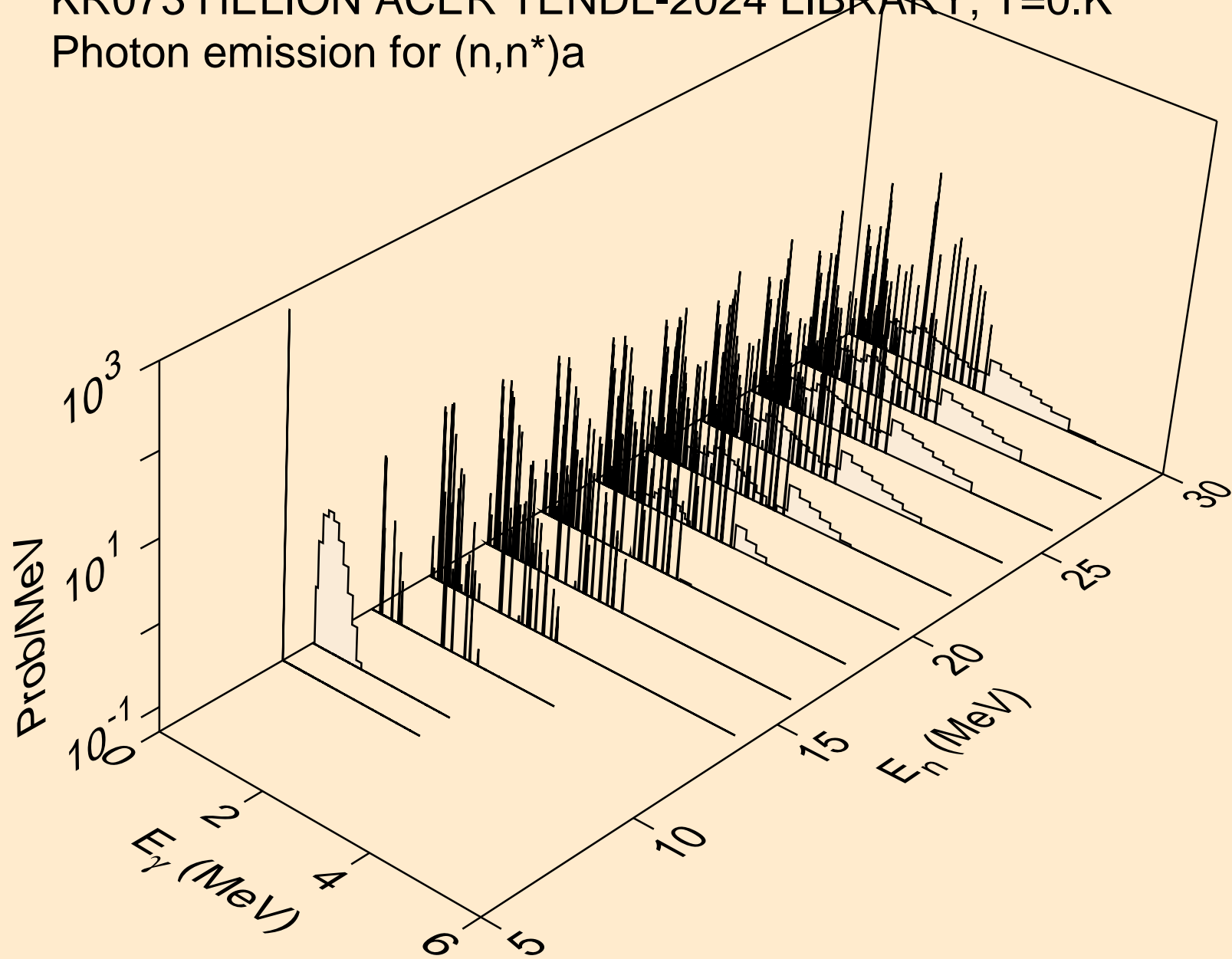

KR073 HELION ACER TENDL-2024 LIBRARY; T=0.K  
Photon emission for (n,2n)a

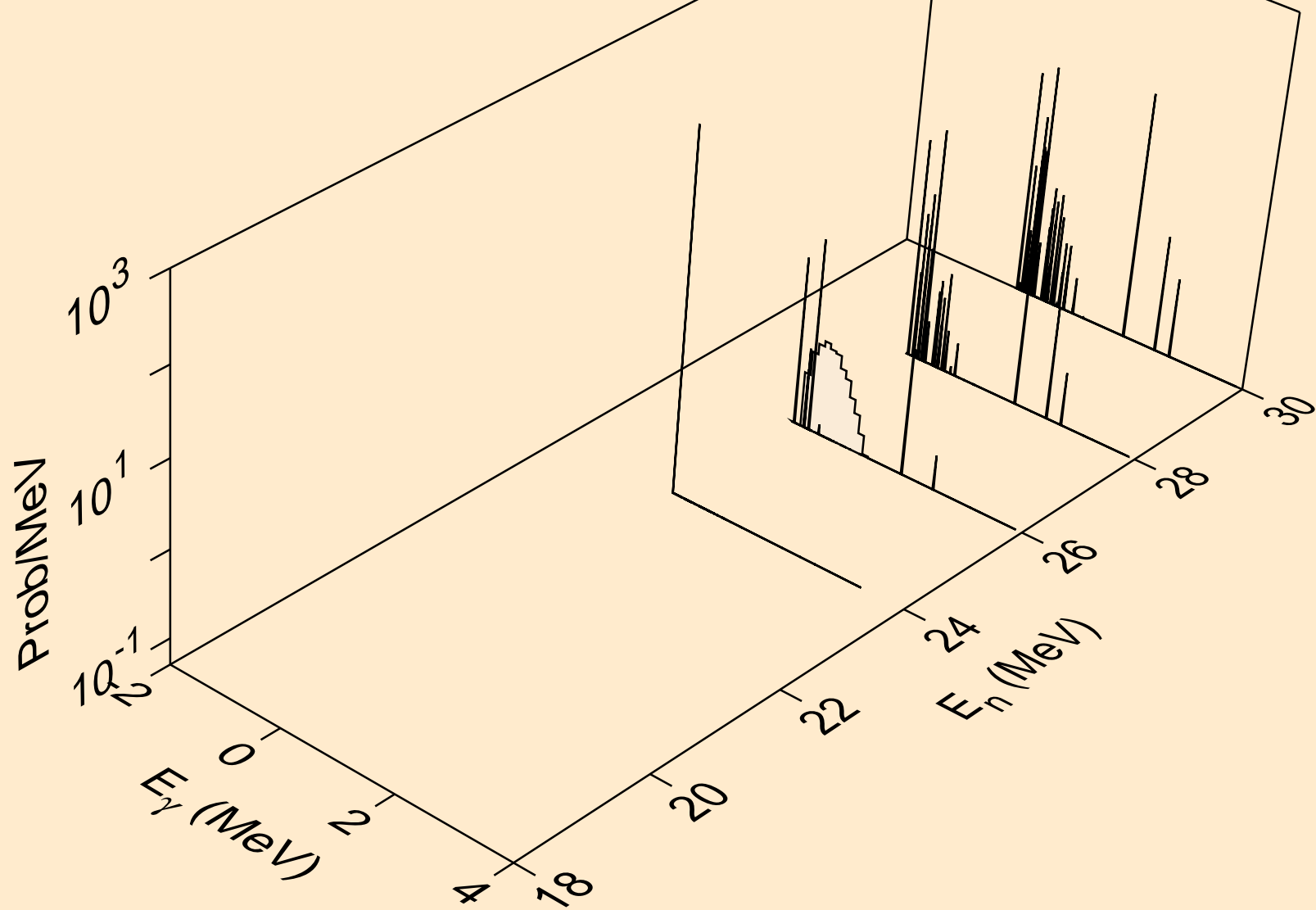

KR073 HELION ACER TENDL-2024 LIBRARY; T=0.K  
Photon emission for (n,n\*)p

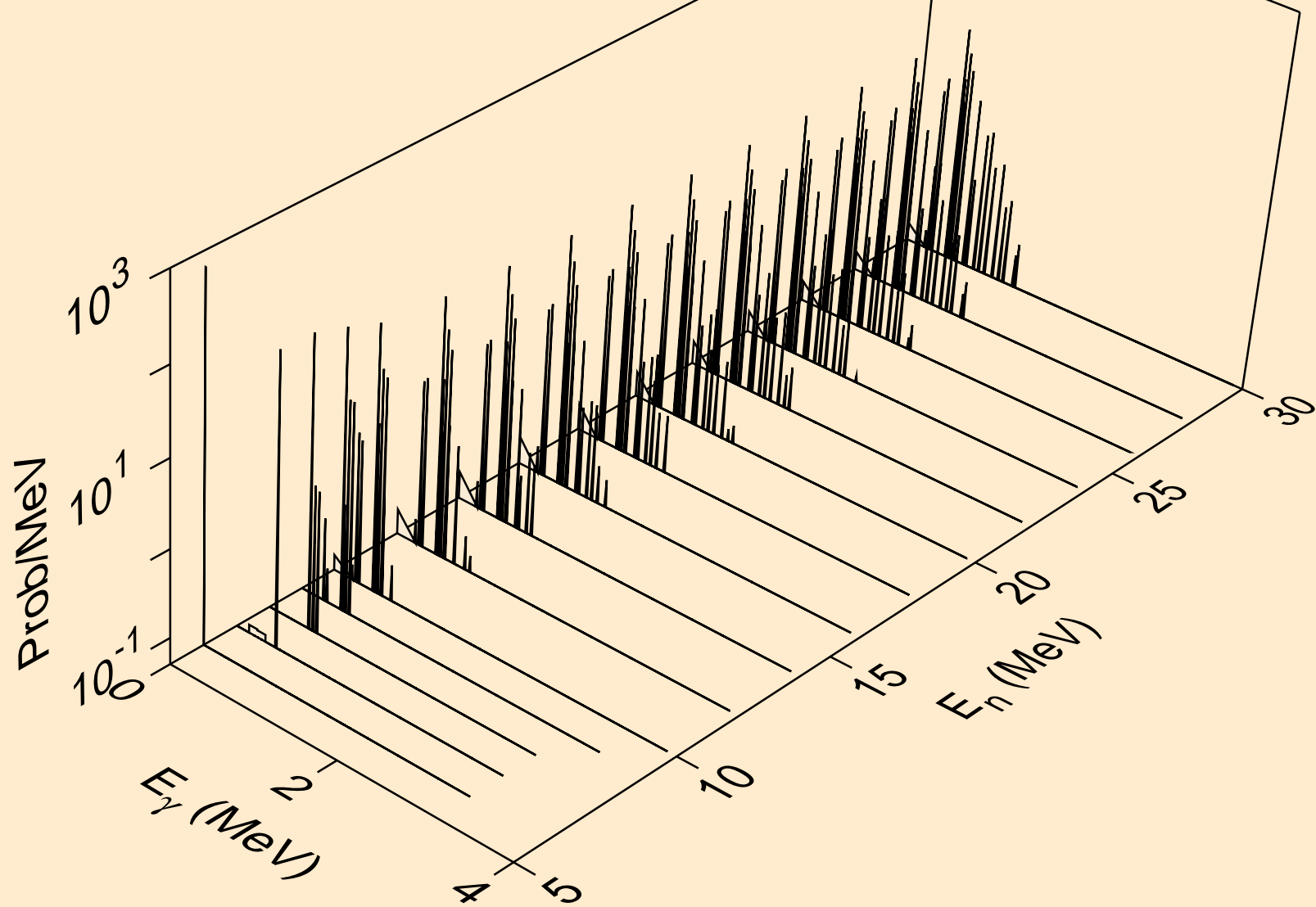

KR073 HELION ACER TENDL-2024 LIBRARY; T=0.K  
Photon emission for (n,n\*)2a

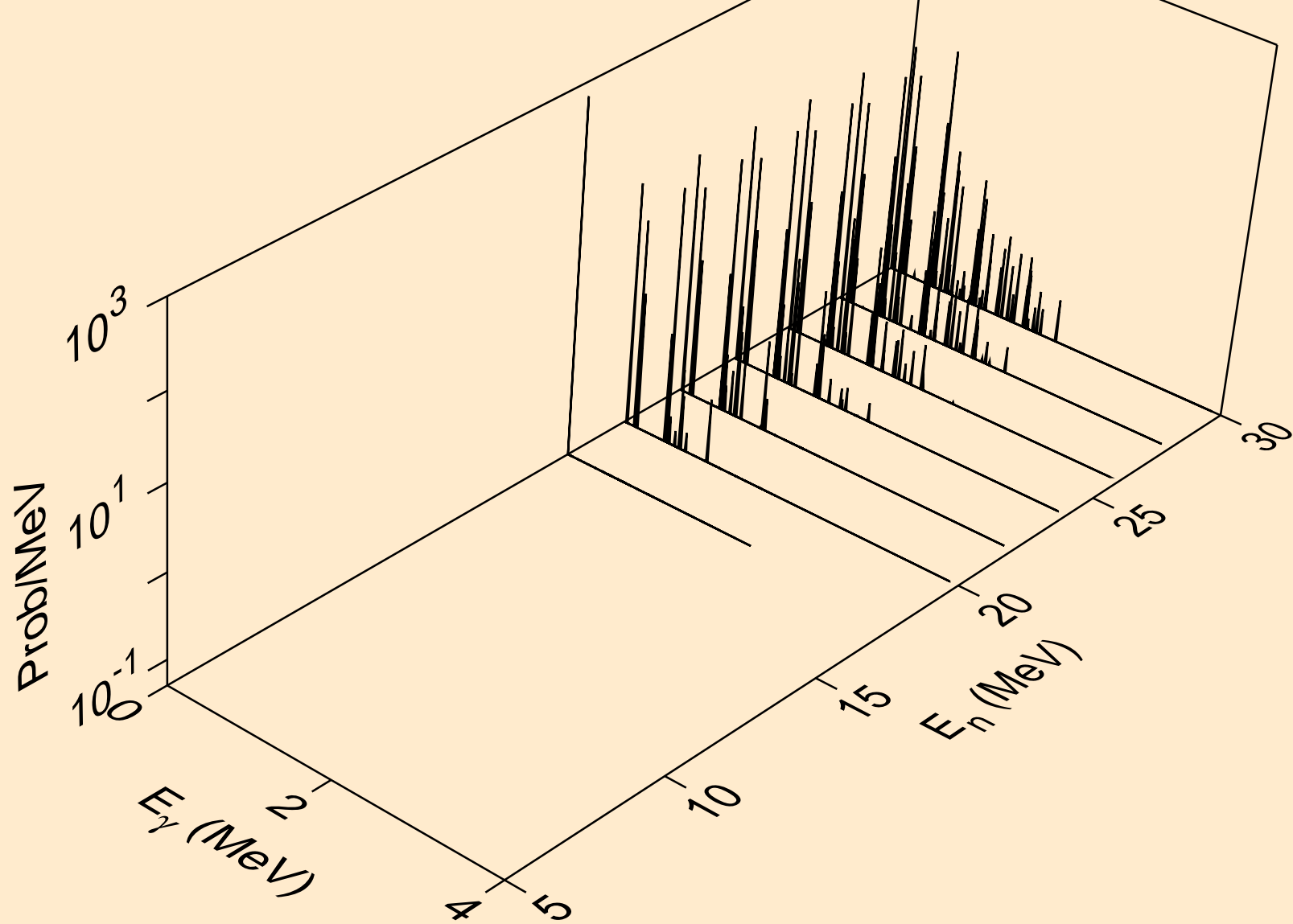

KR073 HELION ACER TENDL-2024 LIBRARY; T=0.K  
Photon emission for (n,n\*)d

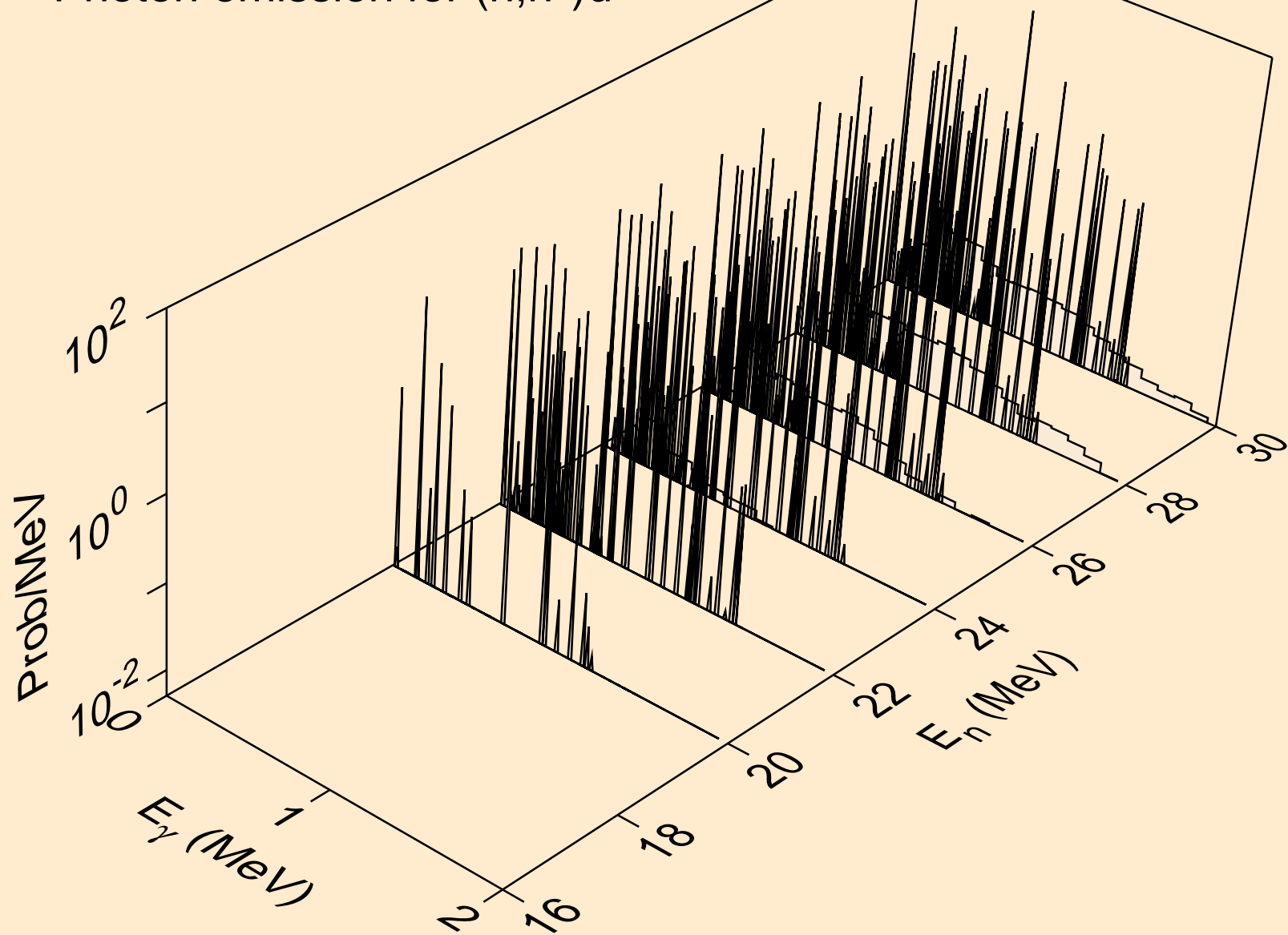

KR073 HELION ACER TENDL-2024 LIBRARY; T=0.K  
Photon emission for (n,n\*)he3

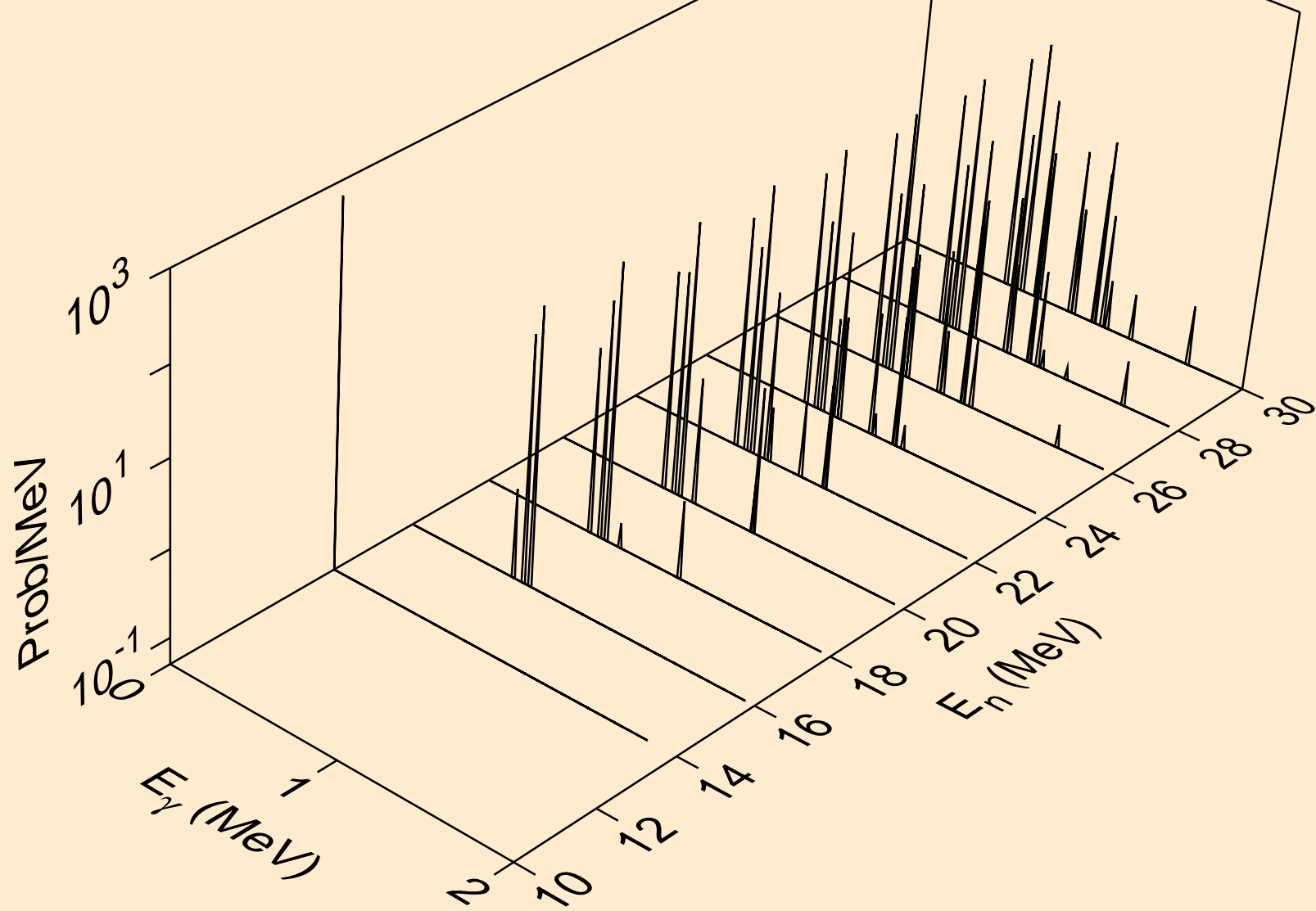

KR073 HELION ACER TENDL-2024 LIBRARY; T=0.K  
Photon emission for (n,2np)

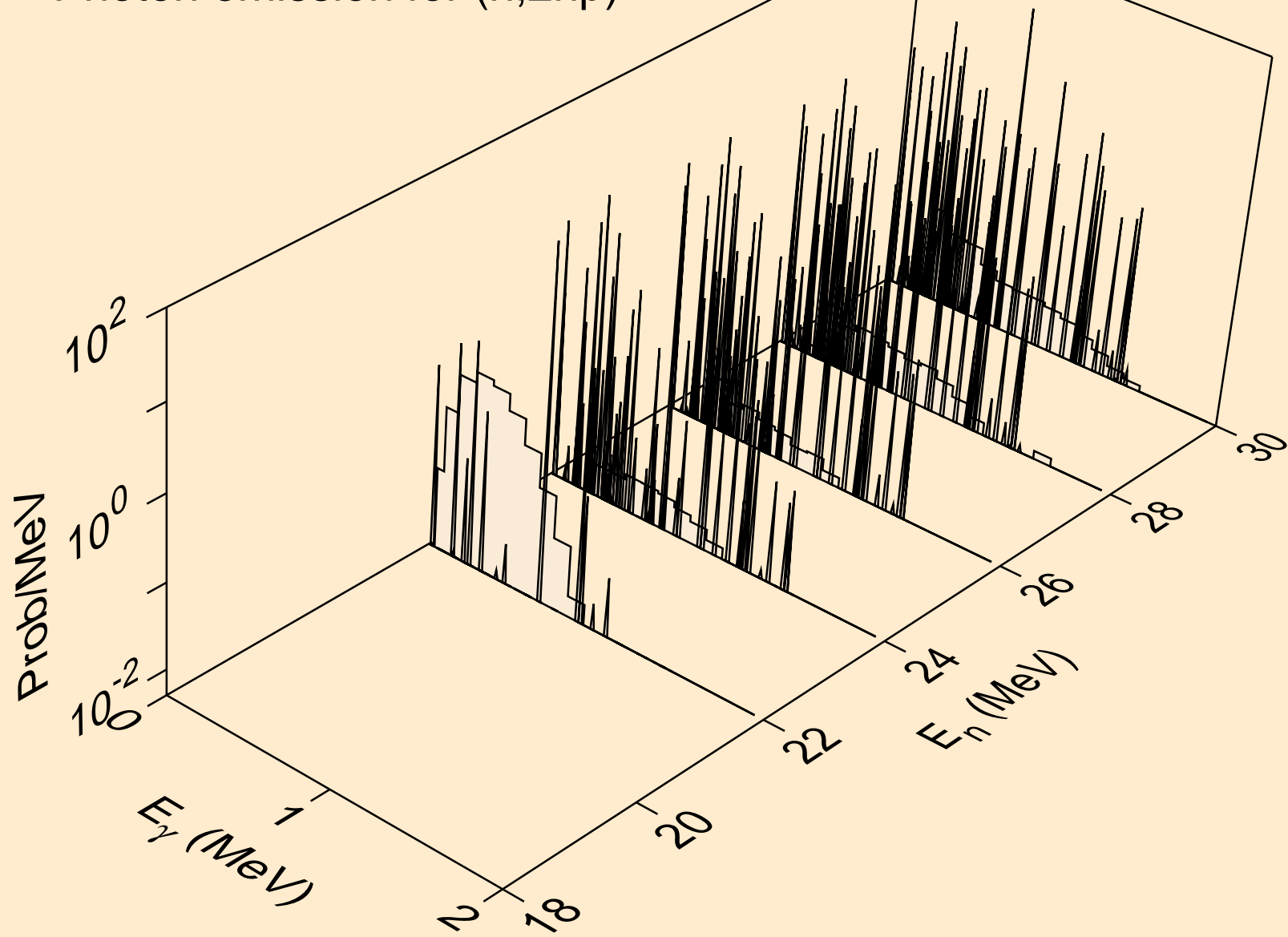

KR073 HELION ACER TENDL-2024 LIBRARY; T=0.K  
Photon emission for (n,n2p)

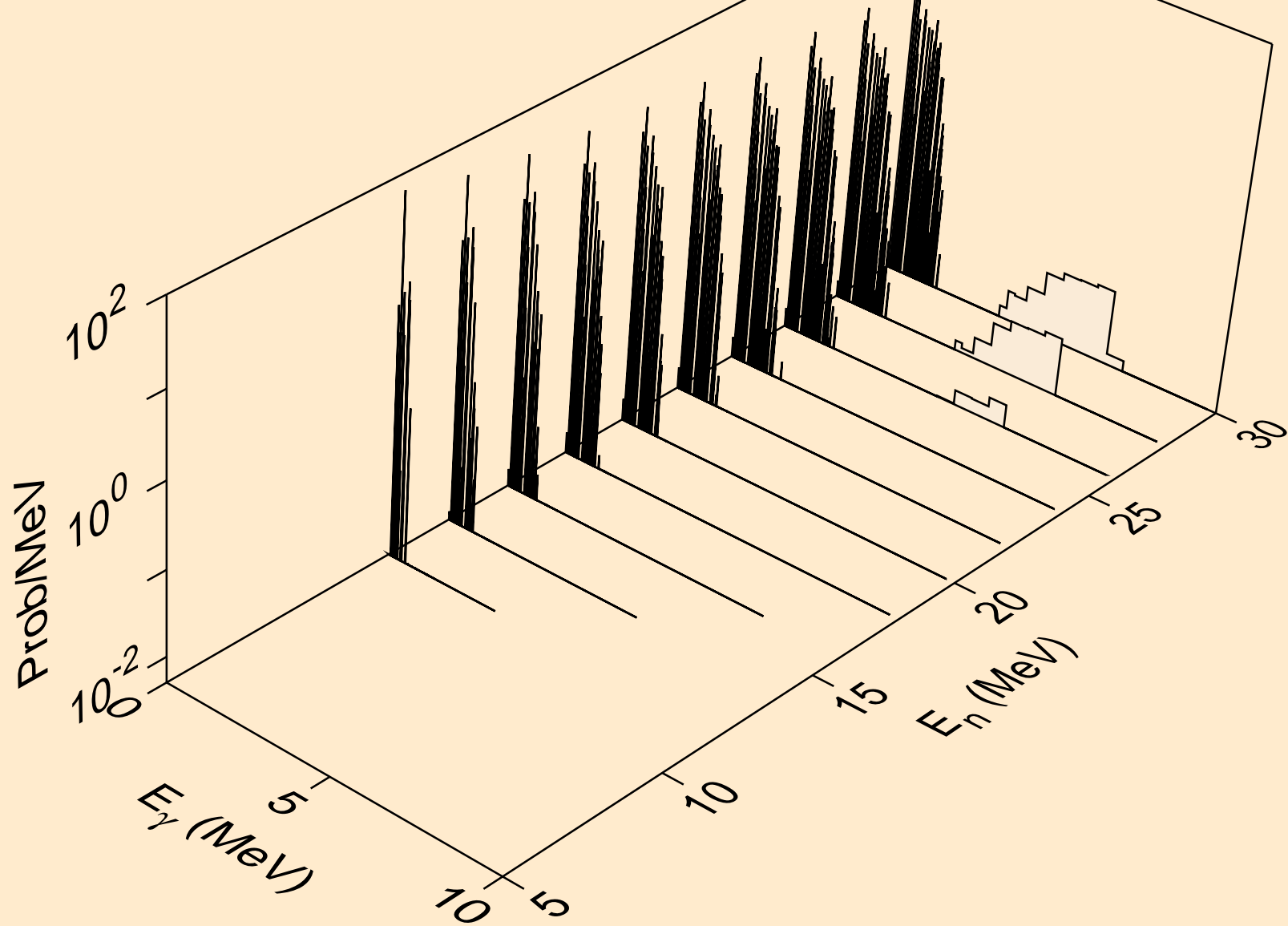

KR073 HELION ACER TENDL-2024 LIBRARY; T=0.K  
Photon emission for (n,npa)

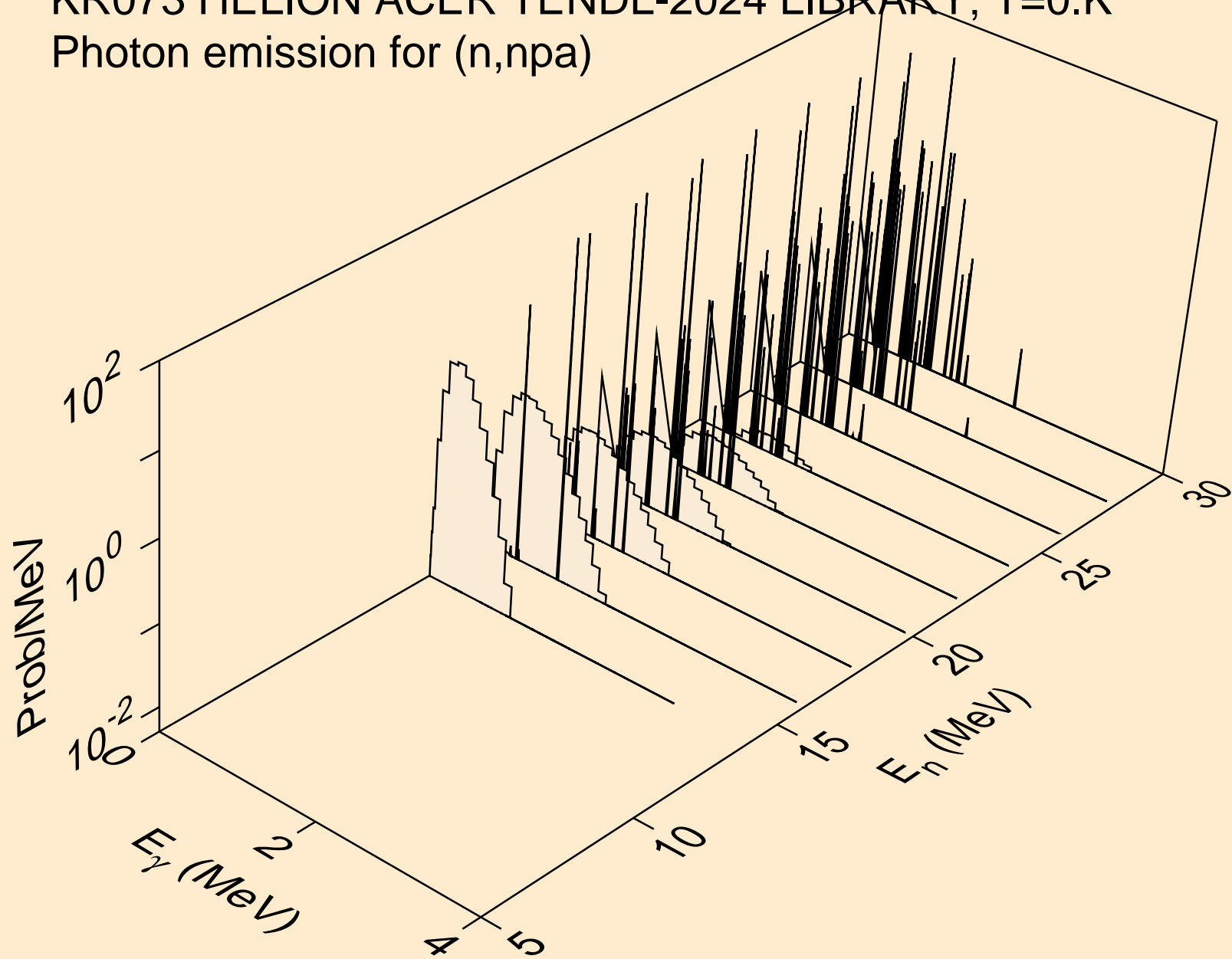

KR073 HELION ACER TENDL-2024 LIBRARY; T=0.K  
Photon emission for (n,gma)

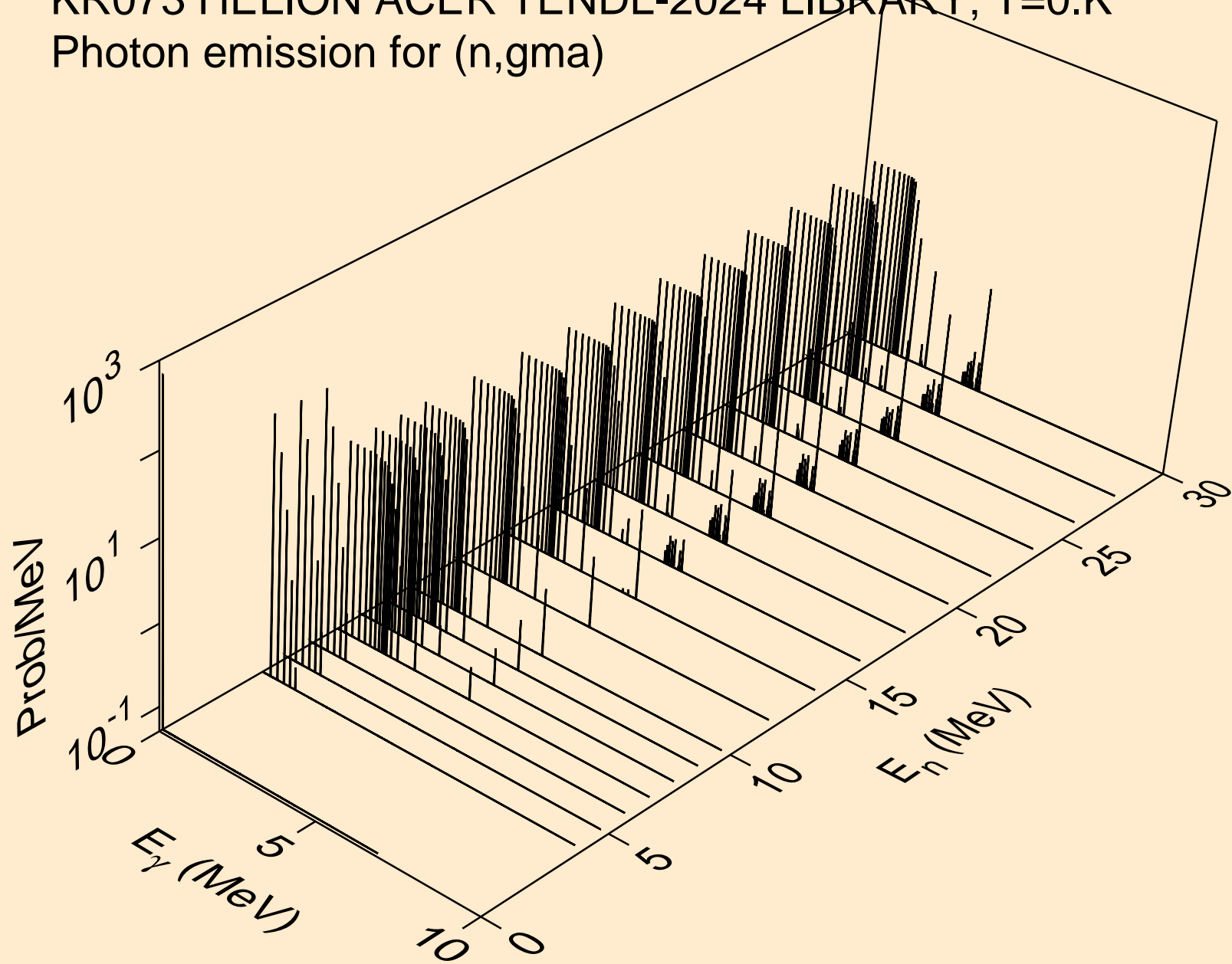

KR073 HELION ACER TENDL-2024 LIBRARY; T=0.K  
Photon emission for (n,p)

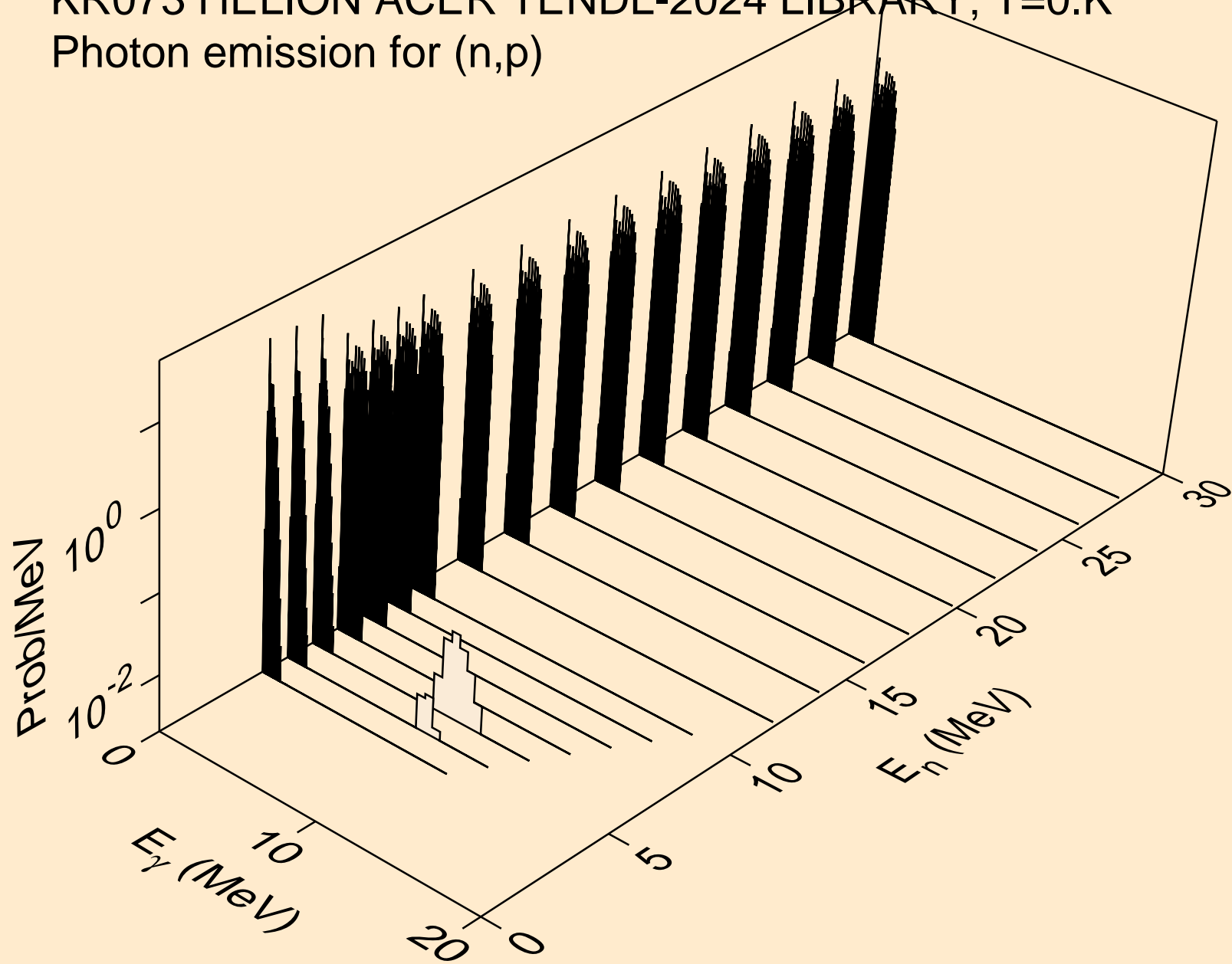

KR073 HELION ACER TENDL-2024 LIBRARY; T=0.K  
Photon emission for (n,d)

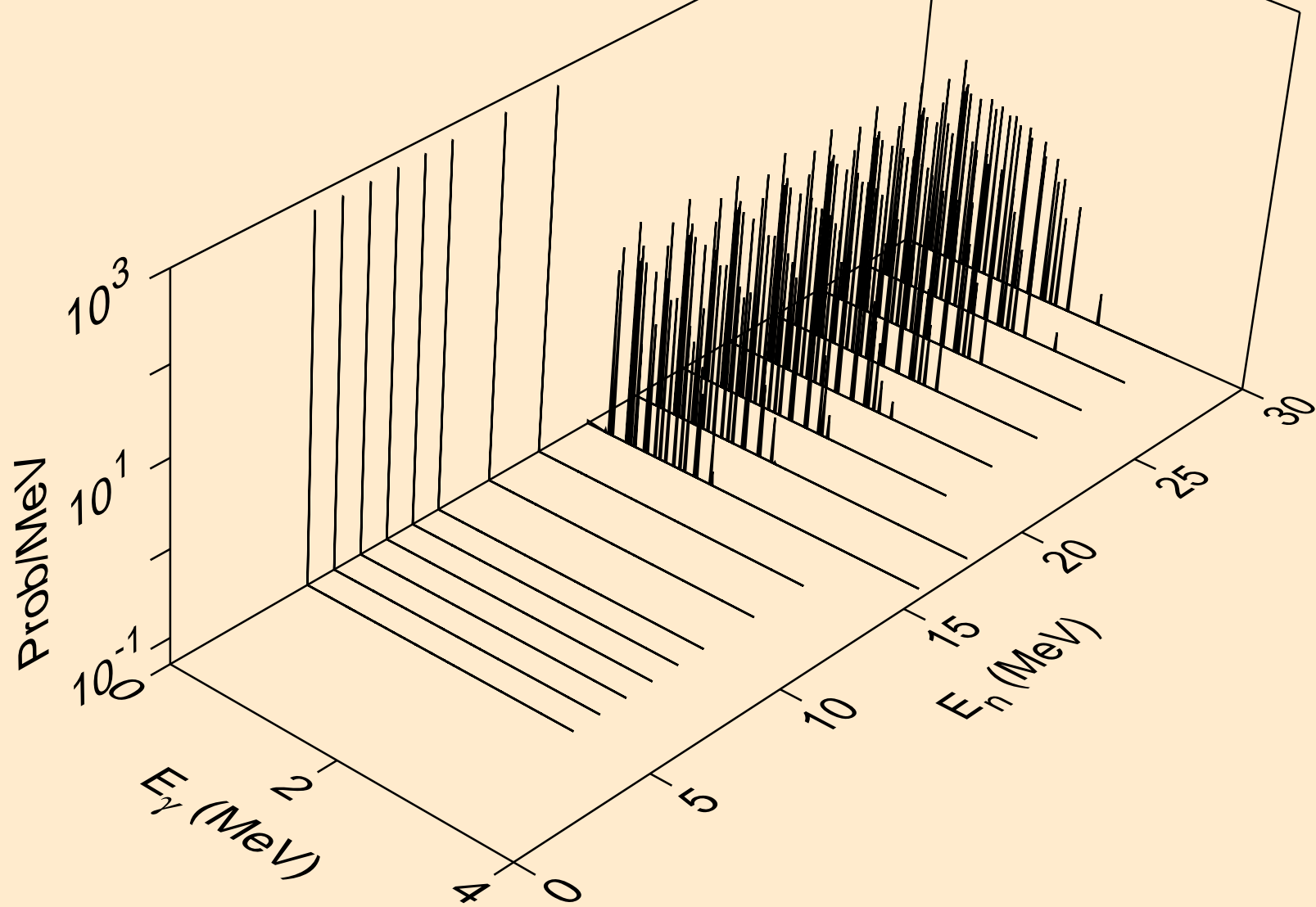

KR073 HELION ACER TENDL-2024 LIBRARY; T=0.K  
Photon emission for (n,t)

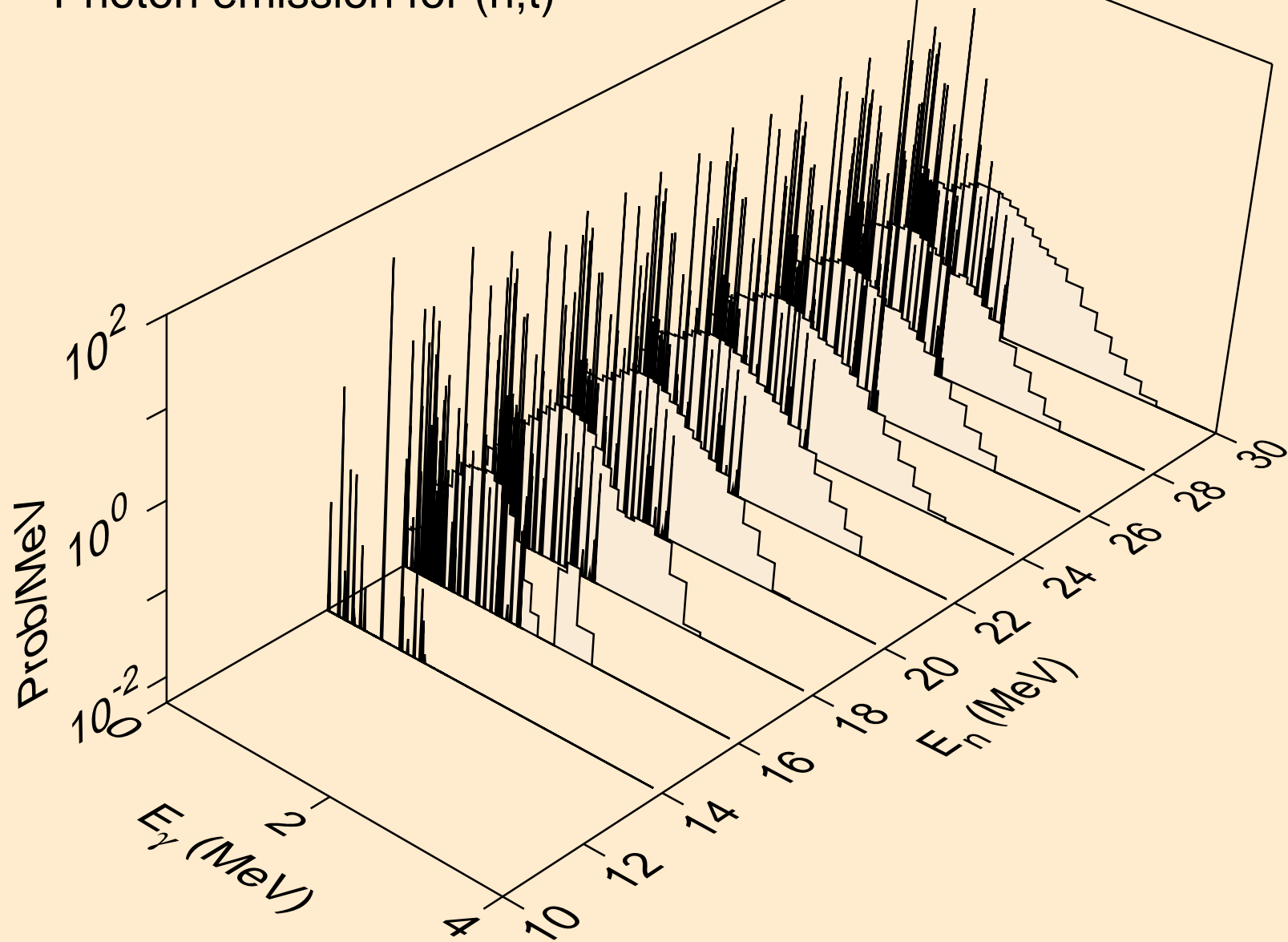

KR073 HELION ACER TENDL-2024 LIBRARY; T=0.K  
Photon emission for inelastic

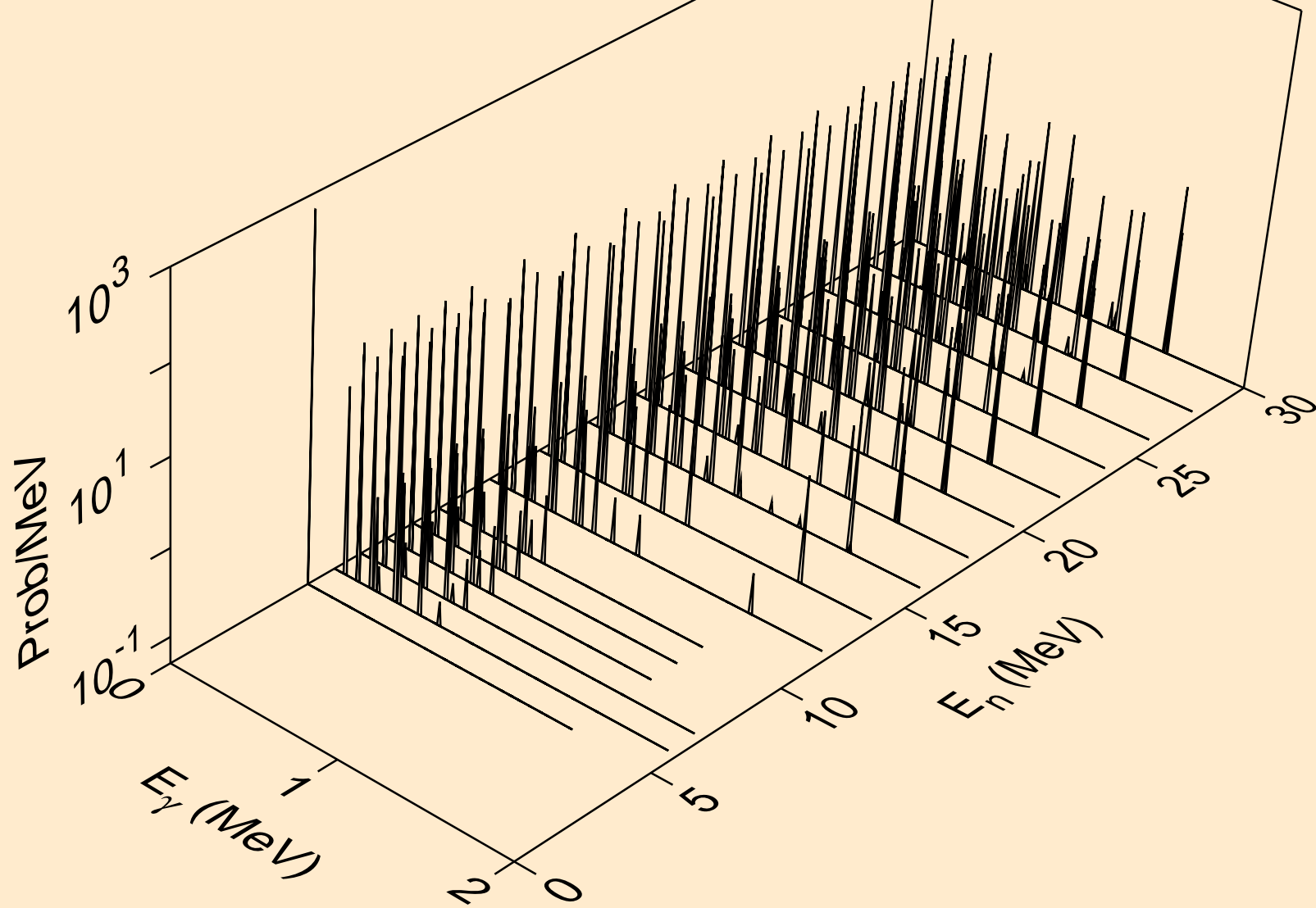

KR073 HELION ACER TENDL-2024 LIBRARY; T=0.K  
Photon emission for (n,a)

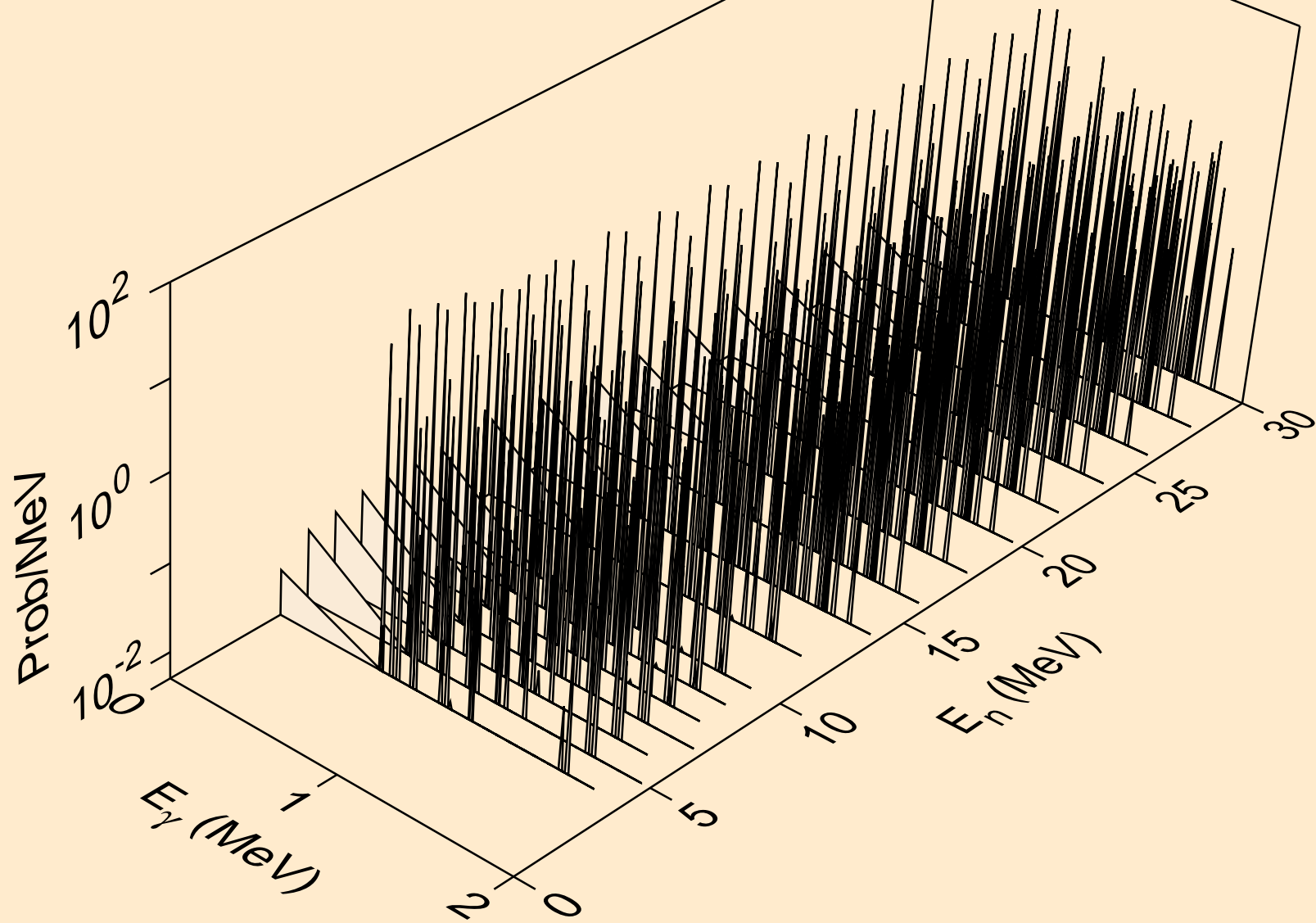

KR073 HELION ACER TENDL-2024 LIBRARY; T=0.K  
Photon emission for (n,2a)

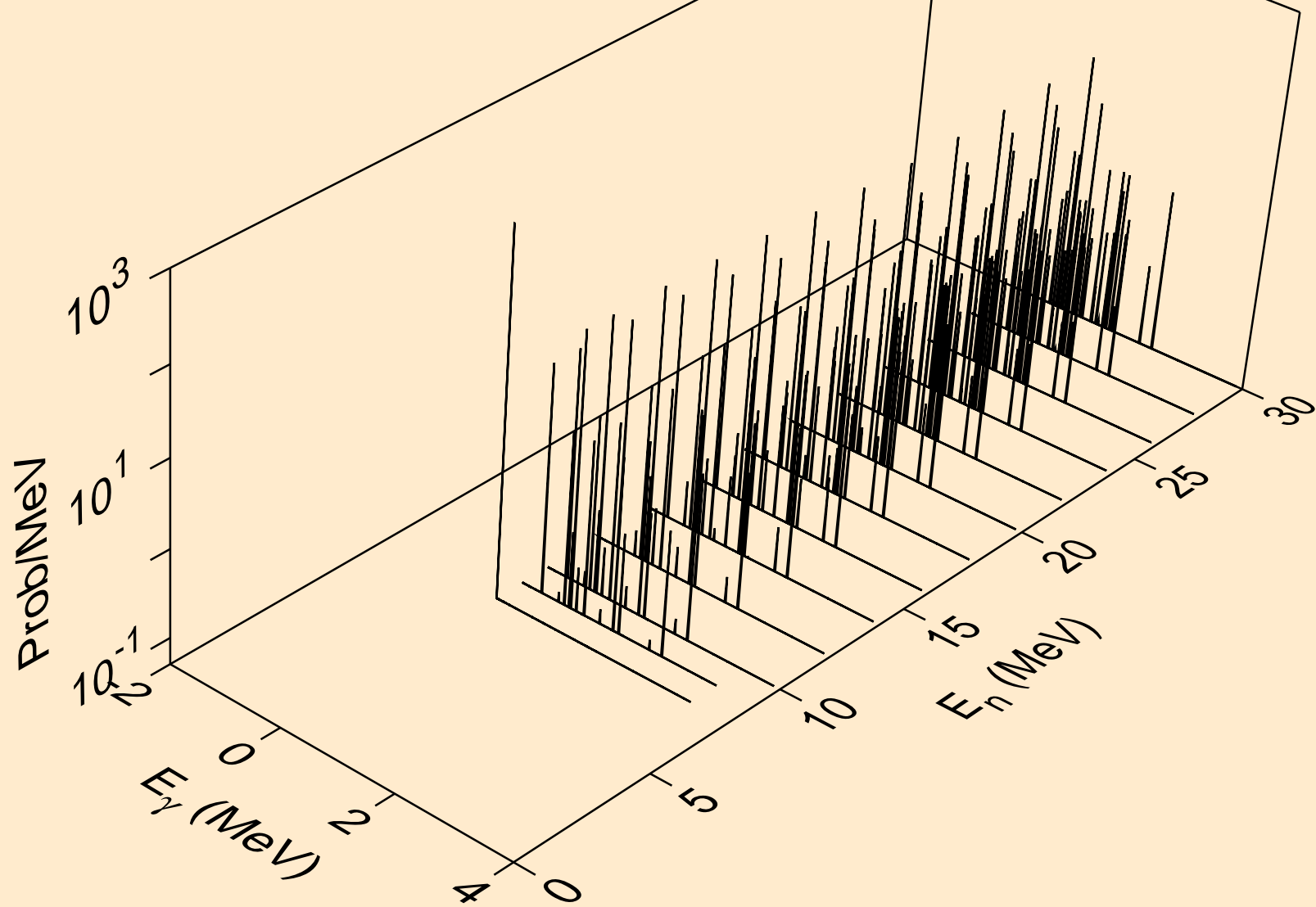

KR073 HELION ACER TENDL-2024 LIBRARY; T=0.K  
Photon emission for (n,2p)

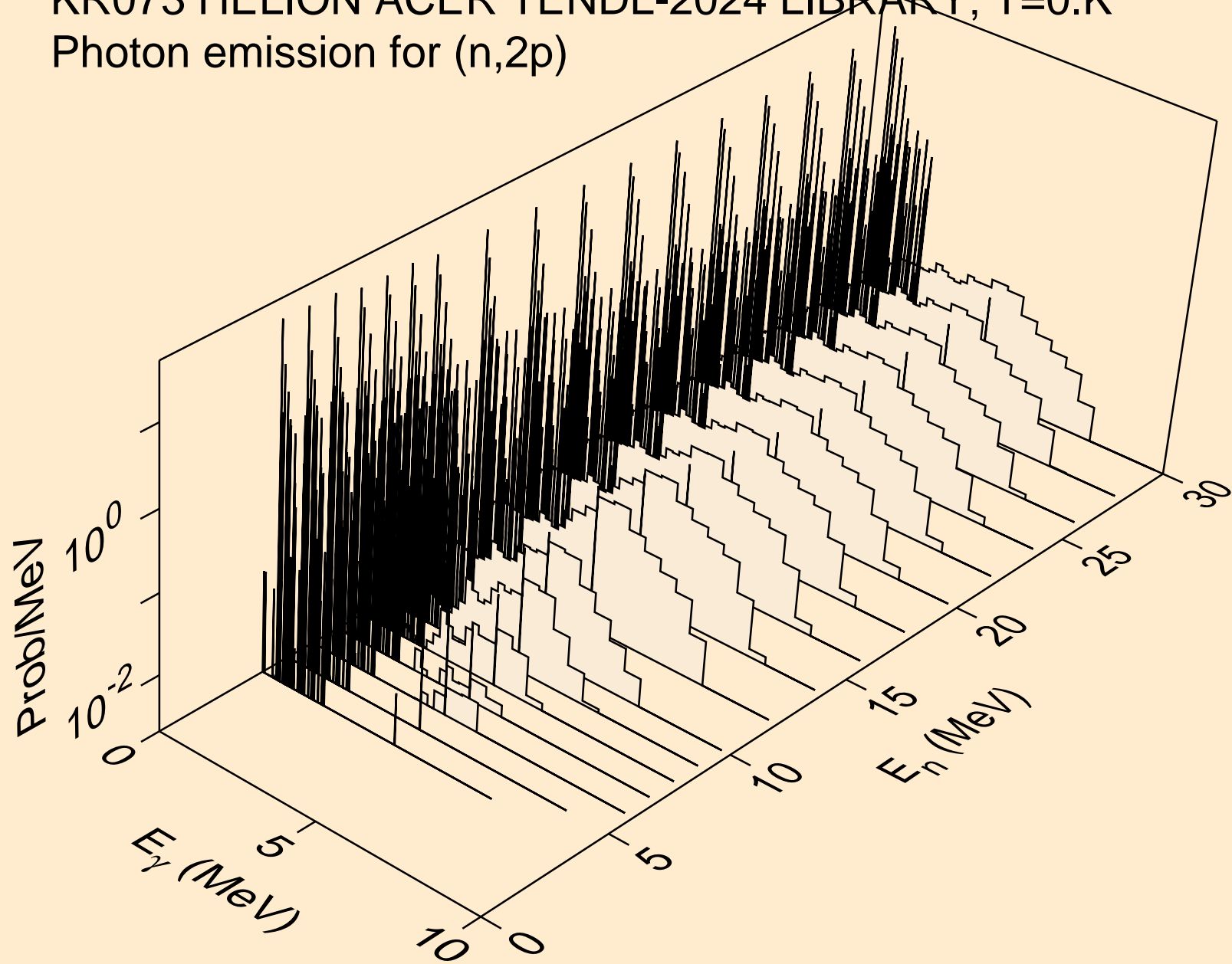

KR073 HELION ACER TENDL-2024 LIBRARY; T=0.K  
Photon emission for (n,pa)

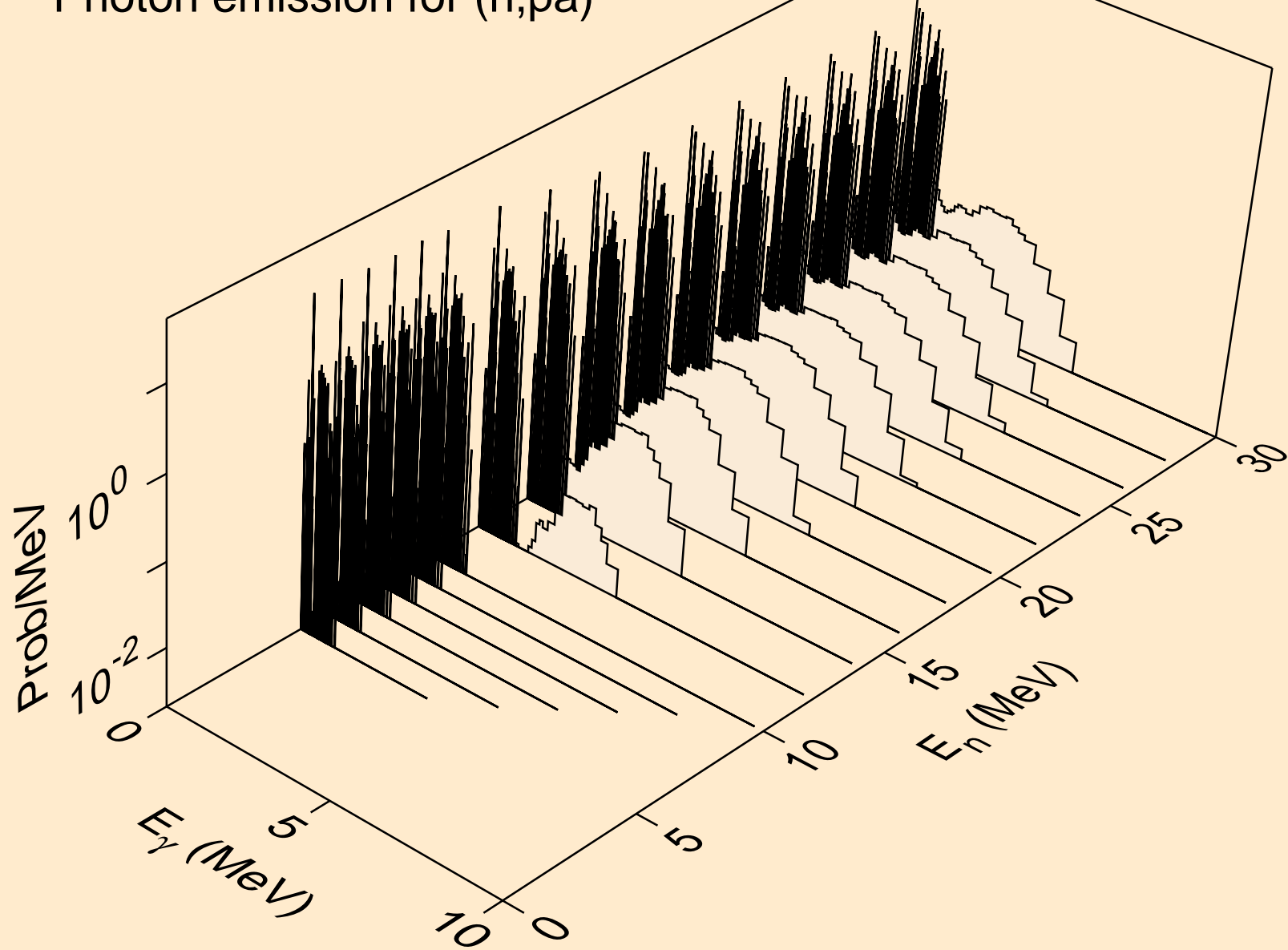

KR073 HELION ACER TENDL-2024 LIBRARY; T=0.K  
Photon emission for (n,pd)

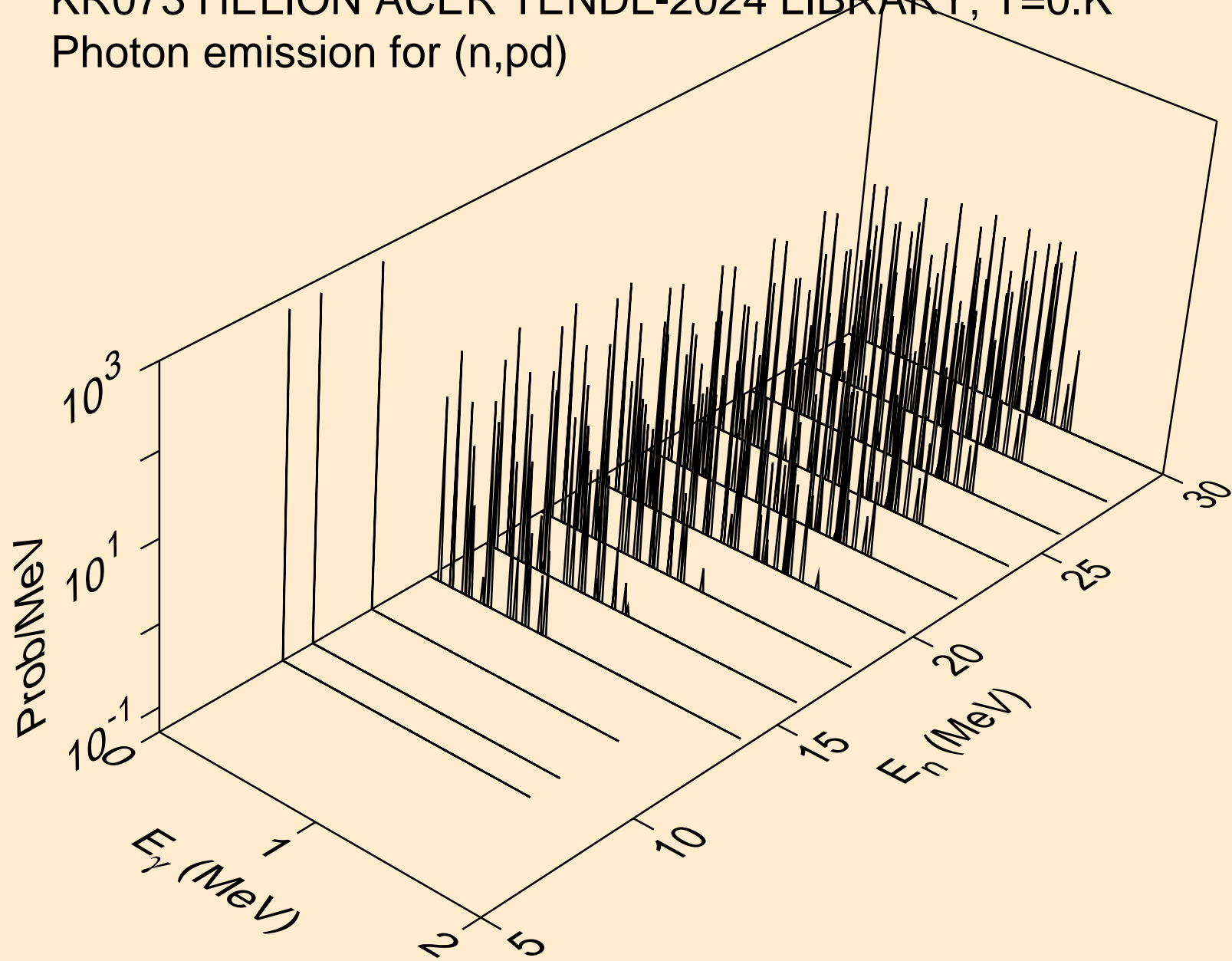

KR073 HELION ACER TENDL-2024 LIBRARY; T=0.K  
Photon emission for (n,pt)

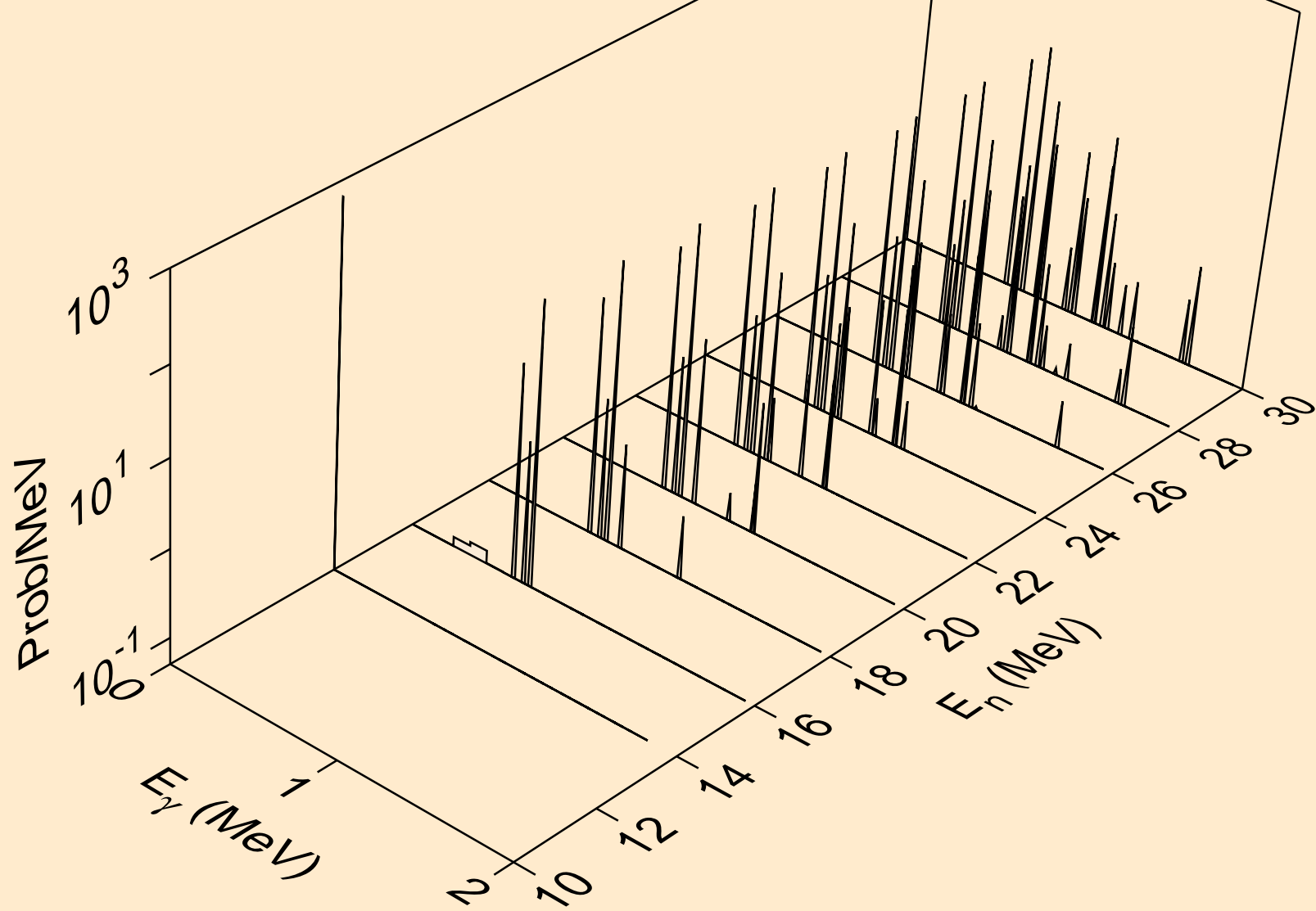

KR073 HELION ACER TENDL-2024 LIBRARY; T=0.K  
Photon emission for (n,da)

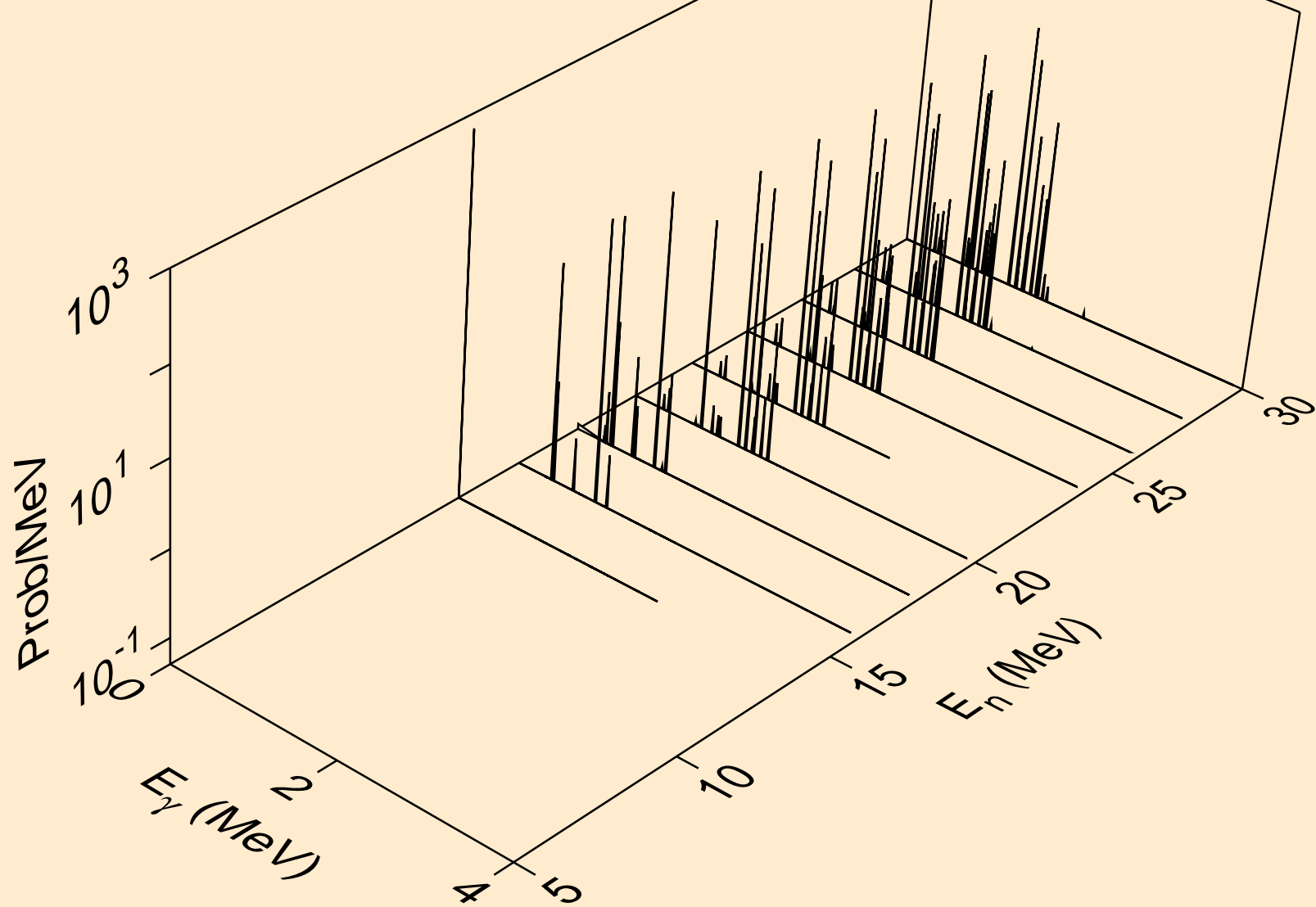

KR073 HELION ACER TENDL-2024 LIBRARY; T=0.K  
Particle heating contributions

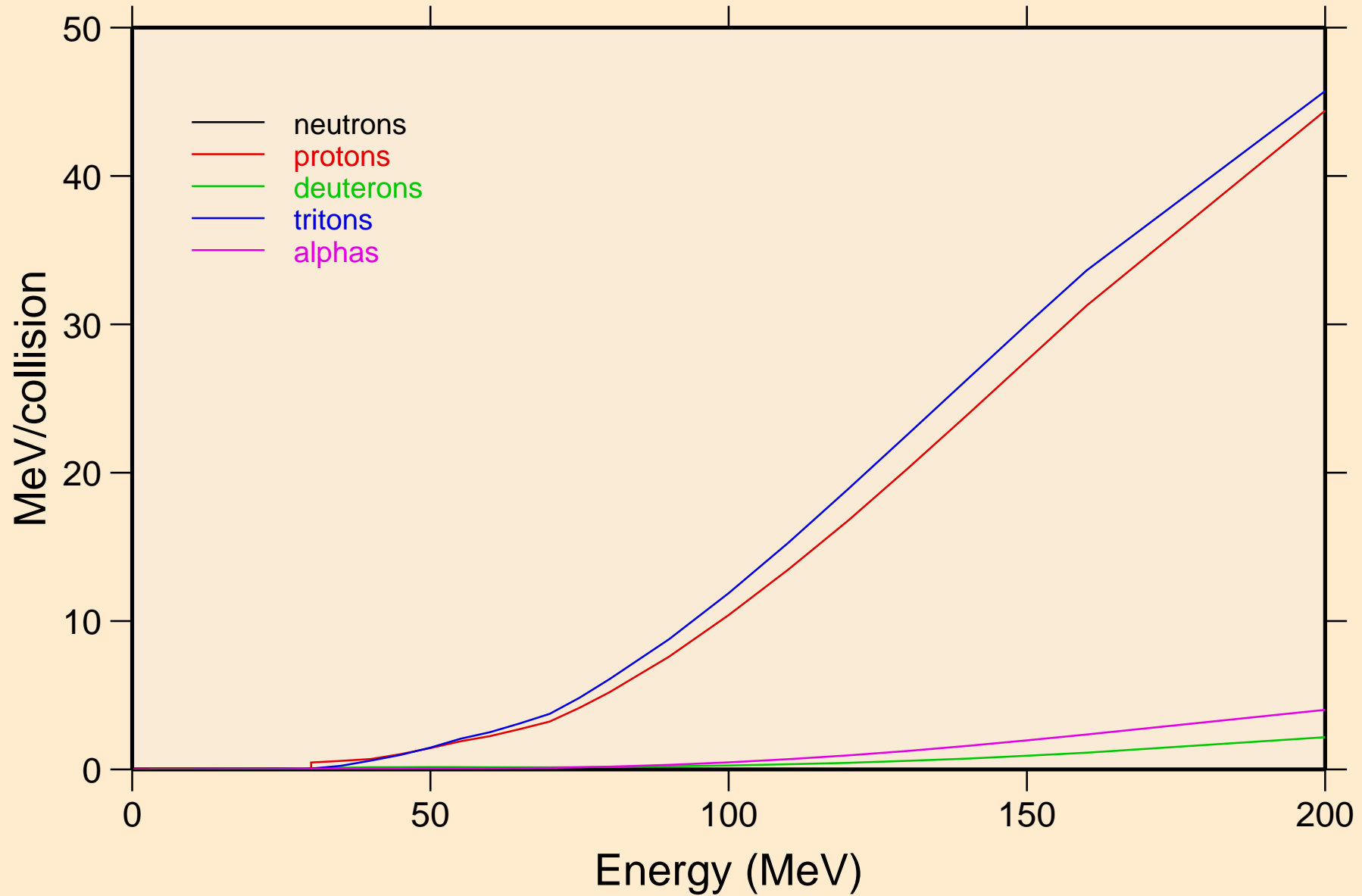

KR073 HELION ACER TENDL-2024 LIBRARY; T=0.K

Recoil Heating

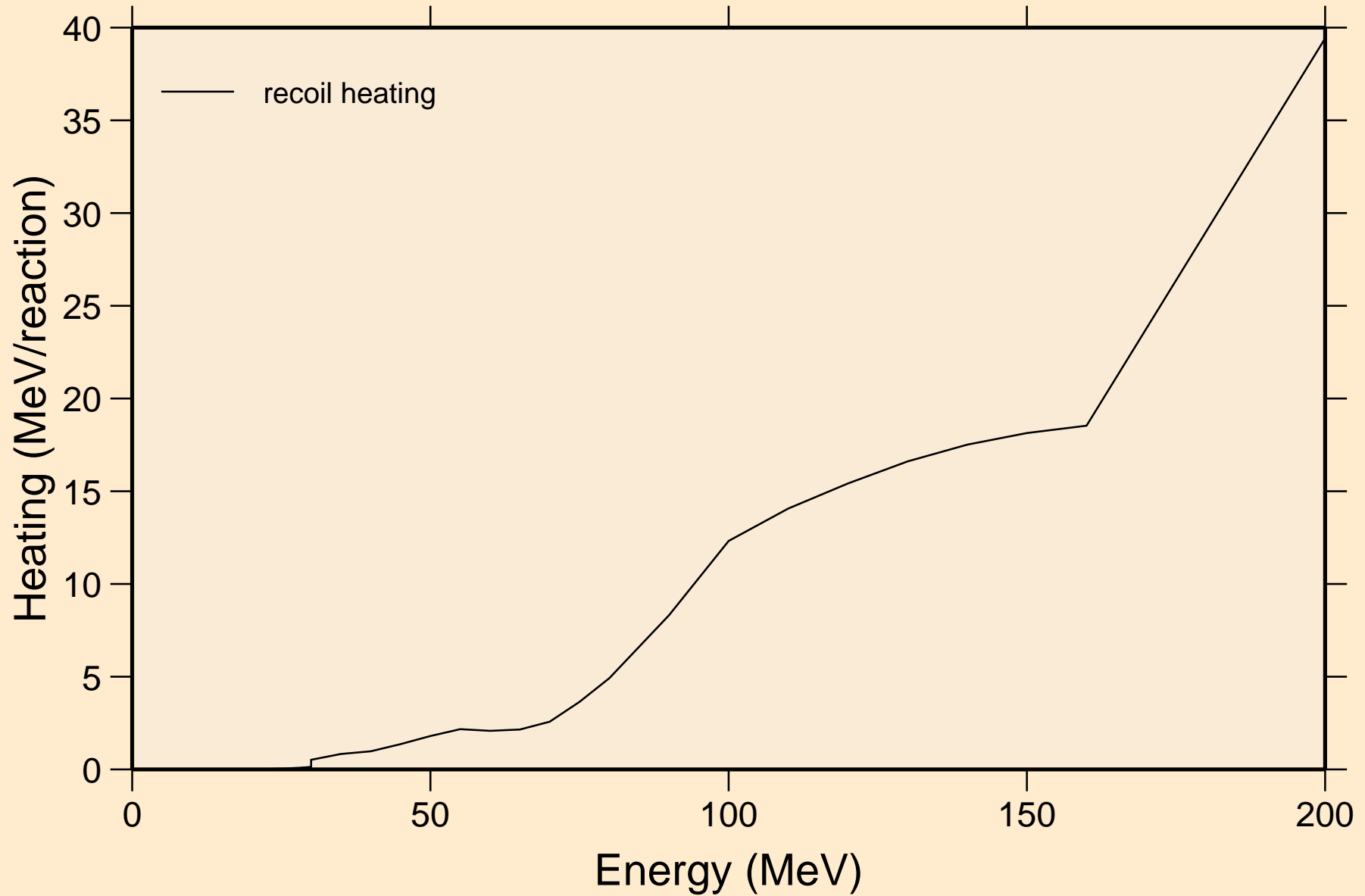

KR073 HELION ACER TENDL-2024 LIBRARY; T=0.K  
Particle production cross sections

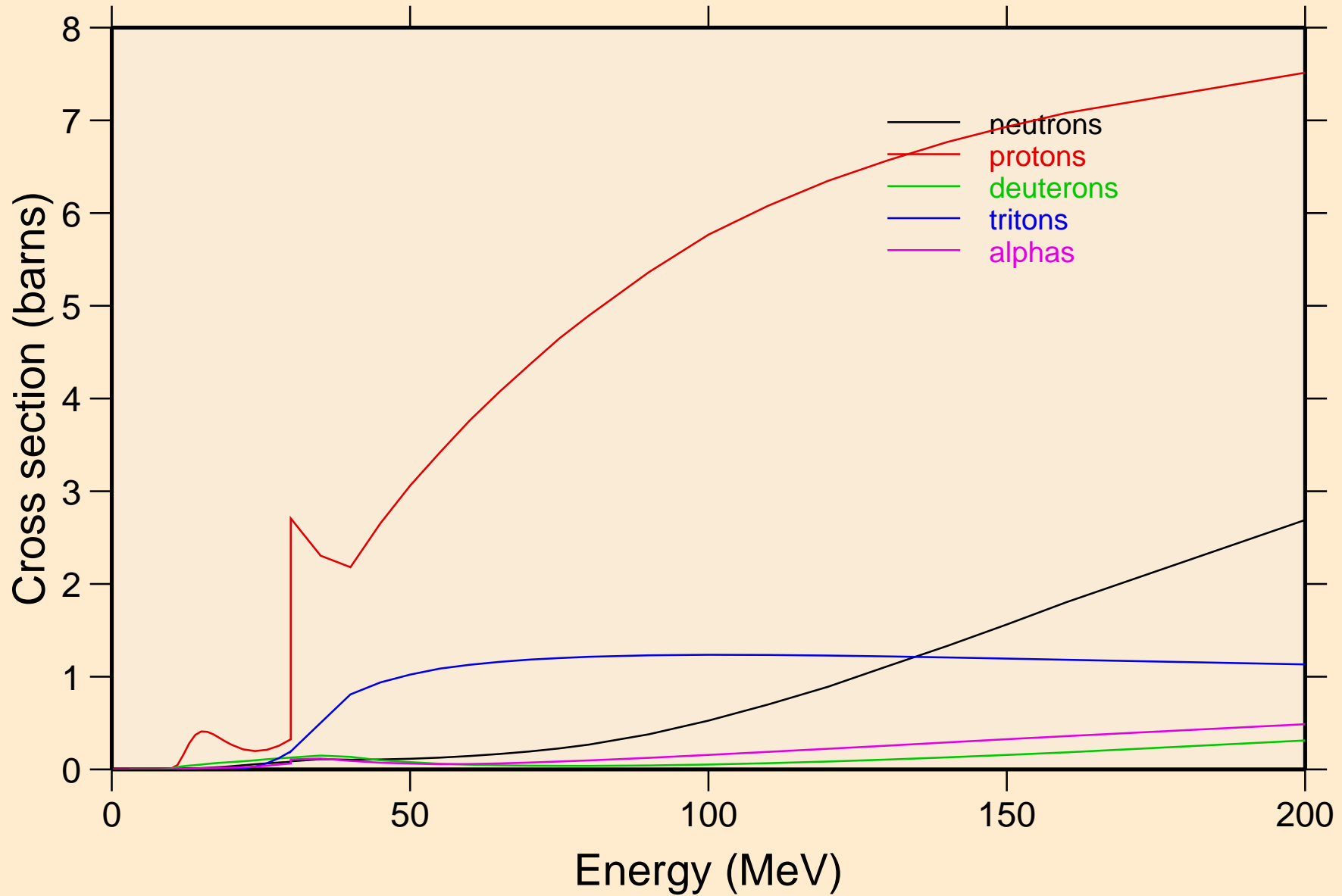

KR073 HELION ACER TENDL-2024 LIBRARY; T=0.K  
neutrons from (s,n)

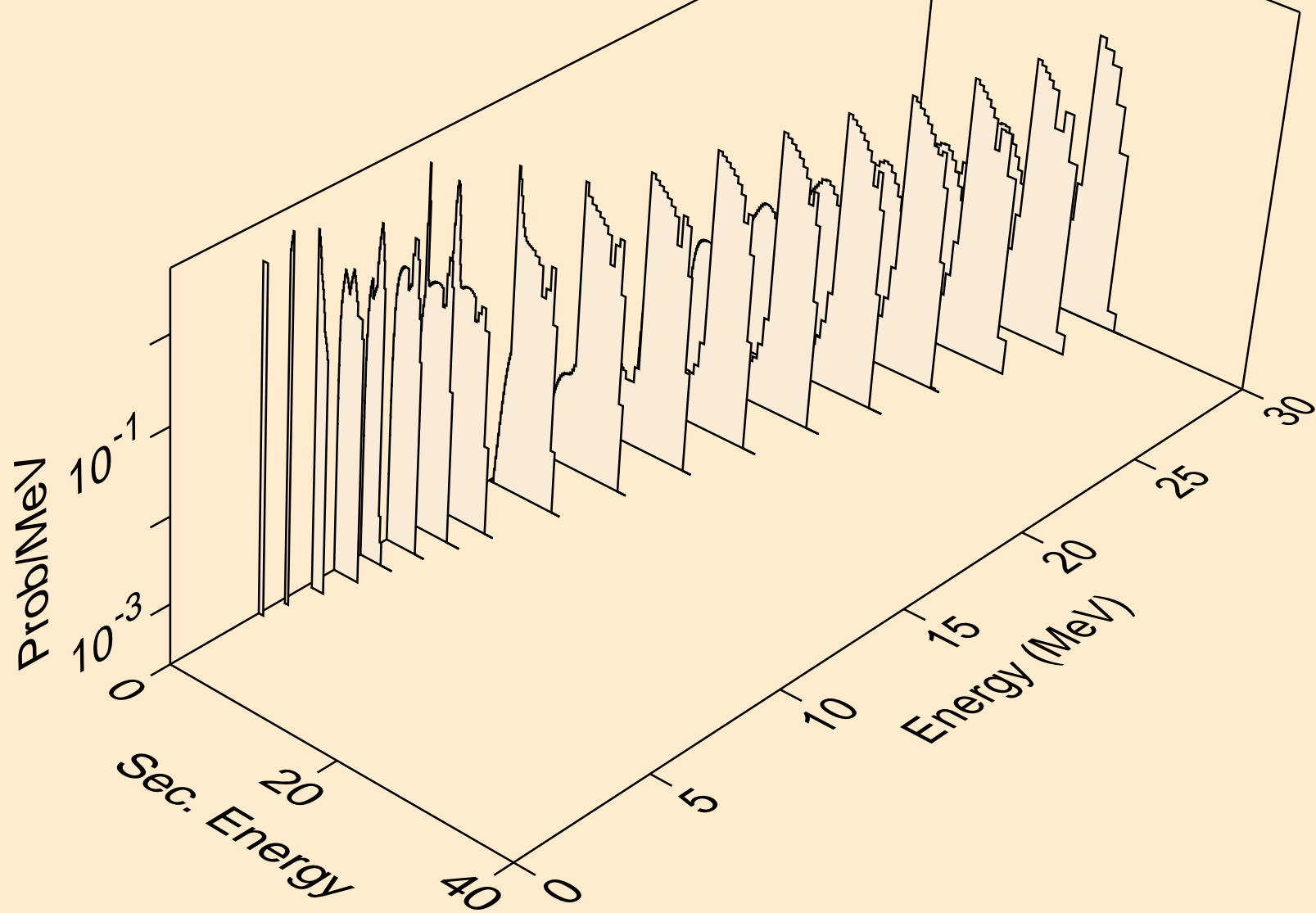

KR073 HELION ACER TENDL-2024 LIBRARY; T=0.K  
neutrons from (s,x)

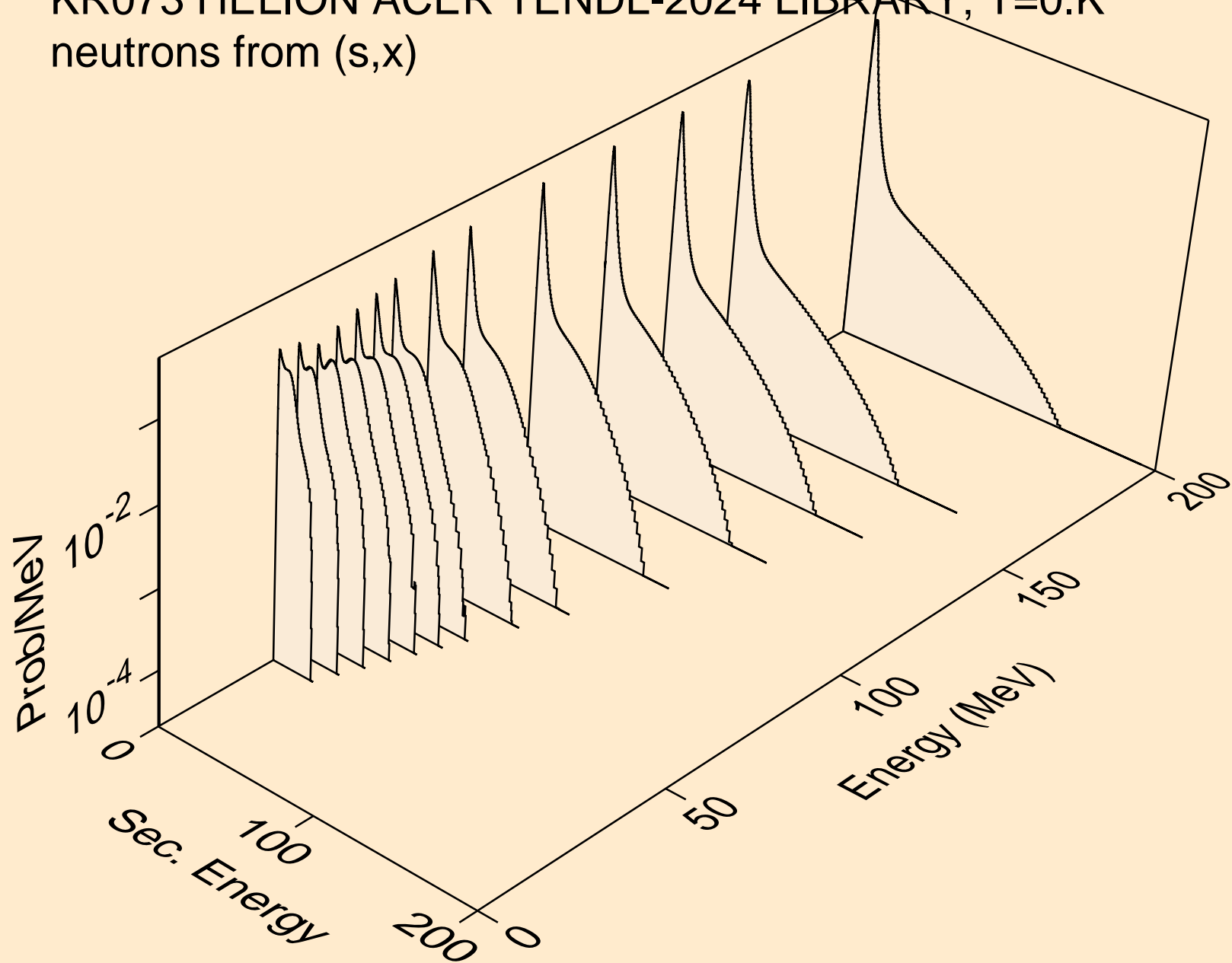

KR073 HELION ACER TENDL-2024 LIBRARY; T=0.K  
neutrons from (s,2n)

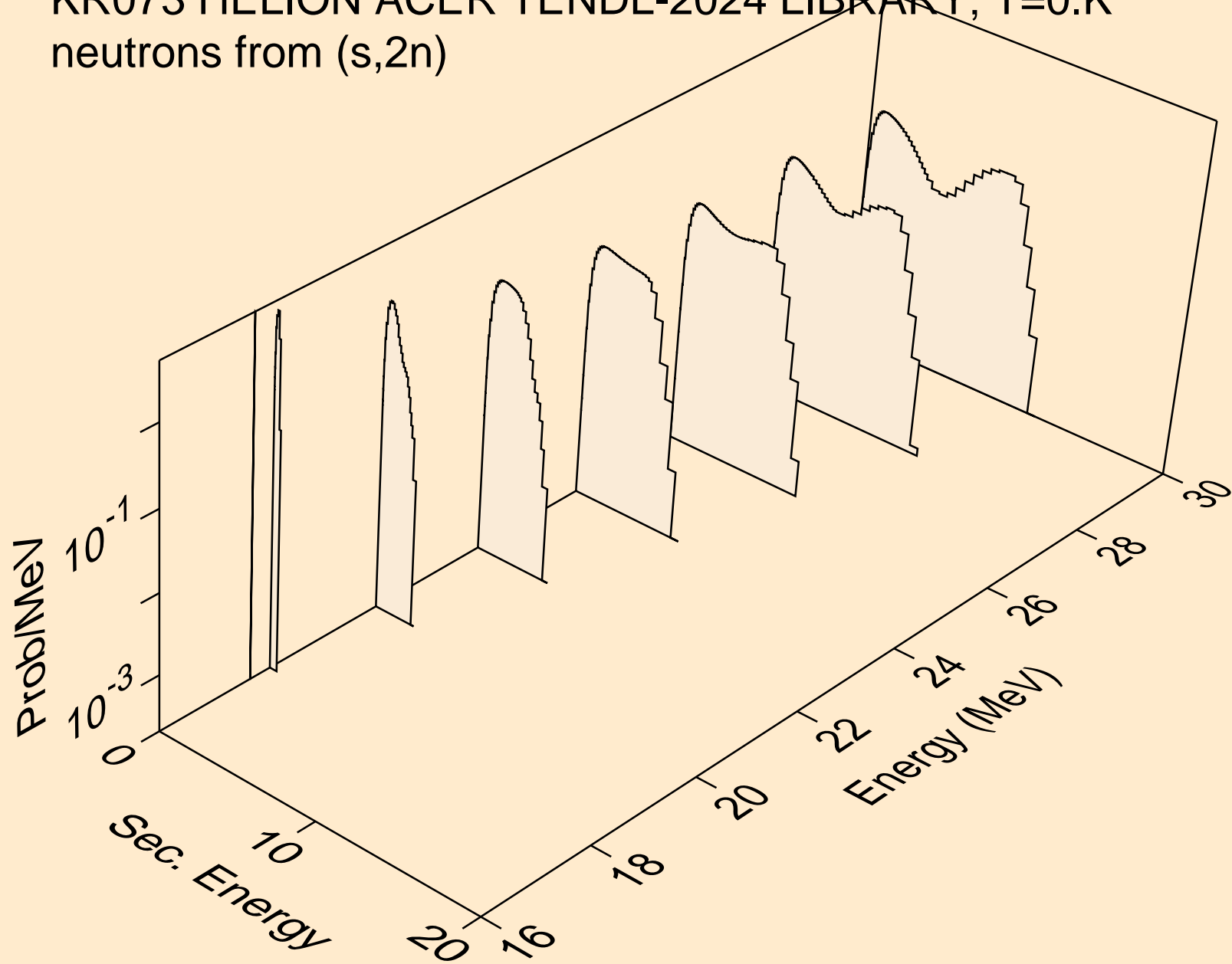

KR073 HELION ACER TENDL-2024 LIBRARY; T=0.K  
neutrons from (s,n\*)a

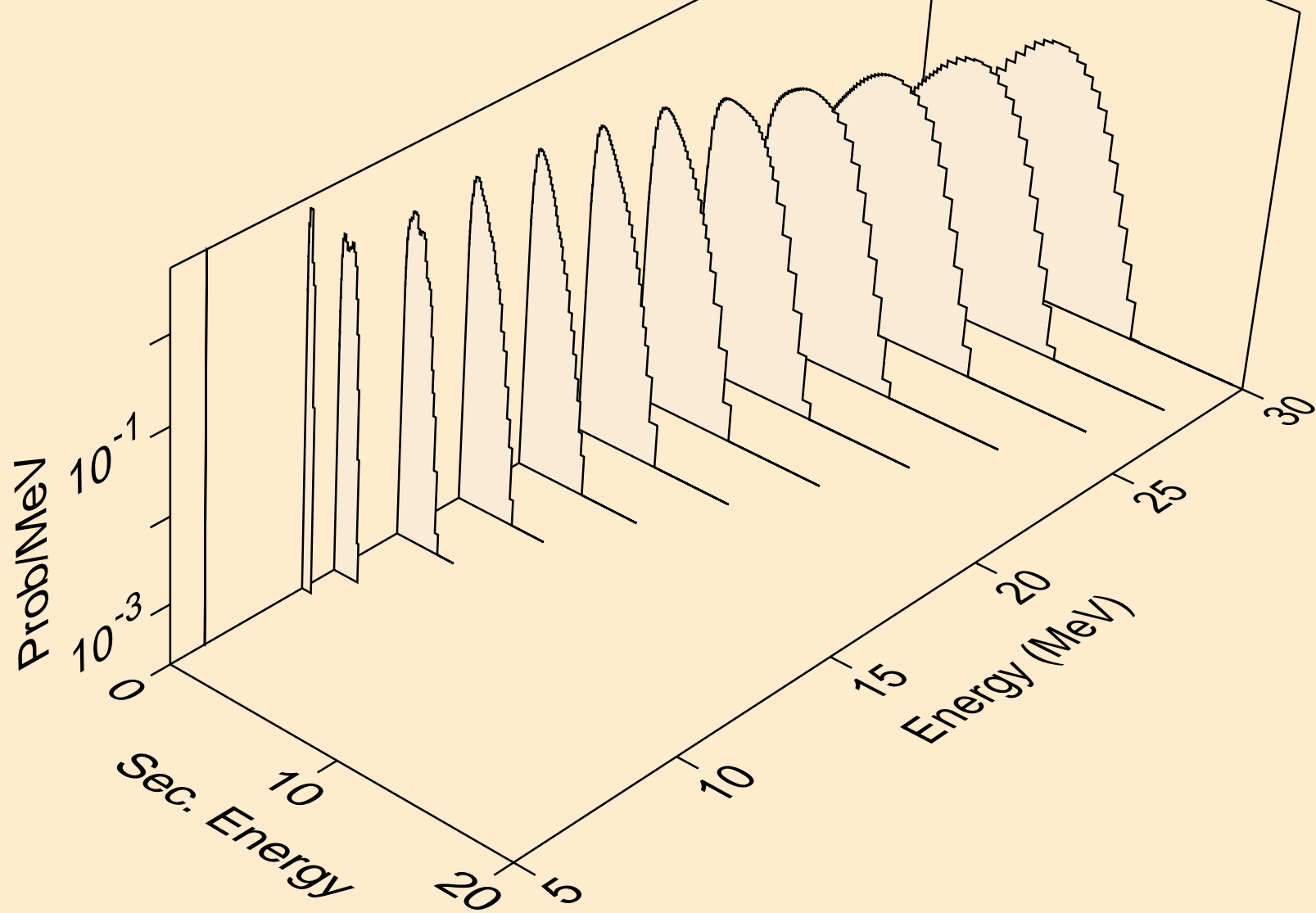

KR073 HELION ACER TENDL-2024 LIBRARY; T=0.K  
neutrons from (s,2n)a

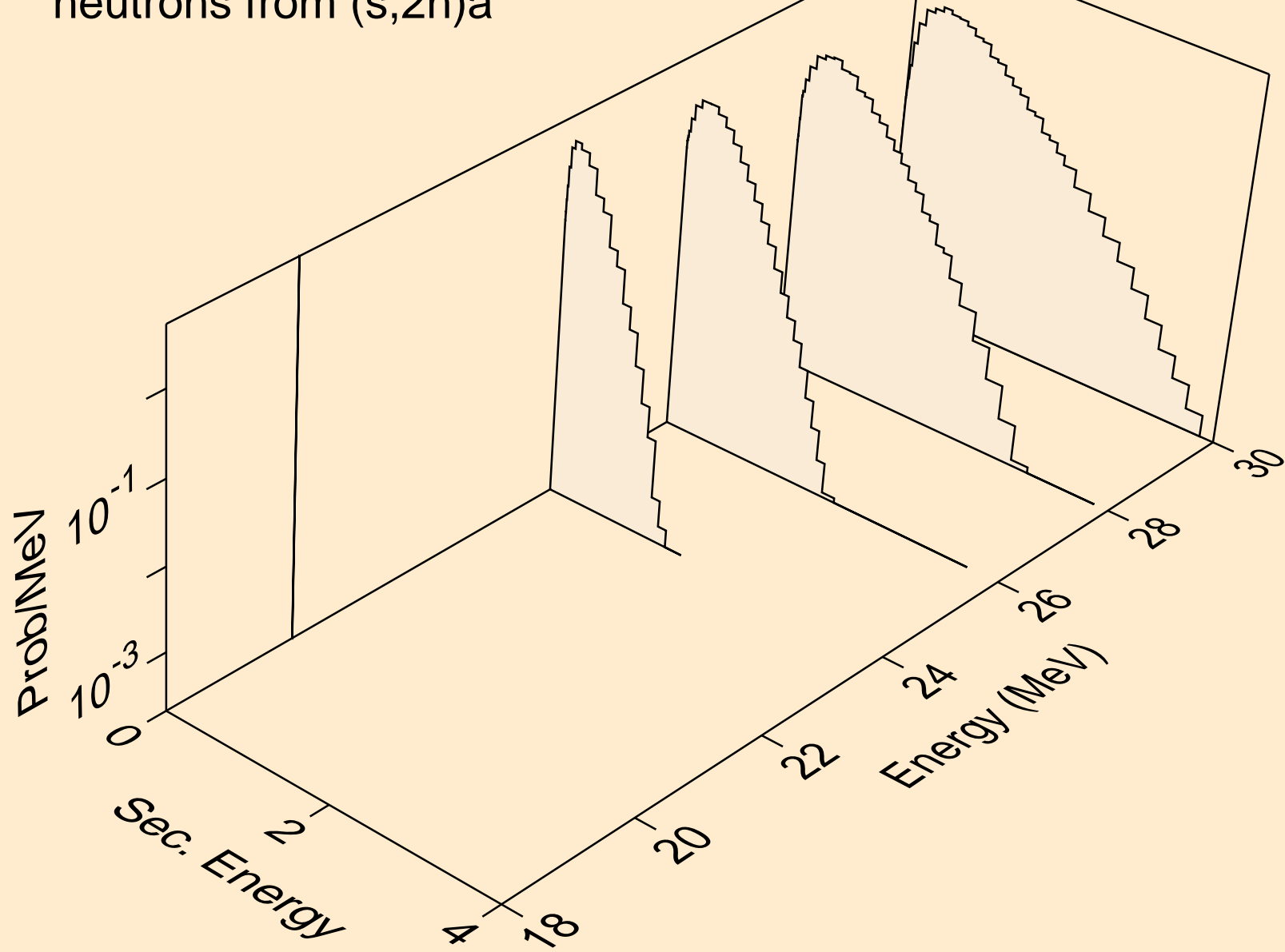

KR073 HELION ACER TENDL-2024 LIBRARY; T=0.K  
neutrons from (s,n\*)p

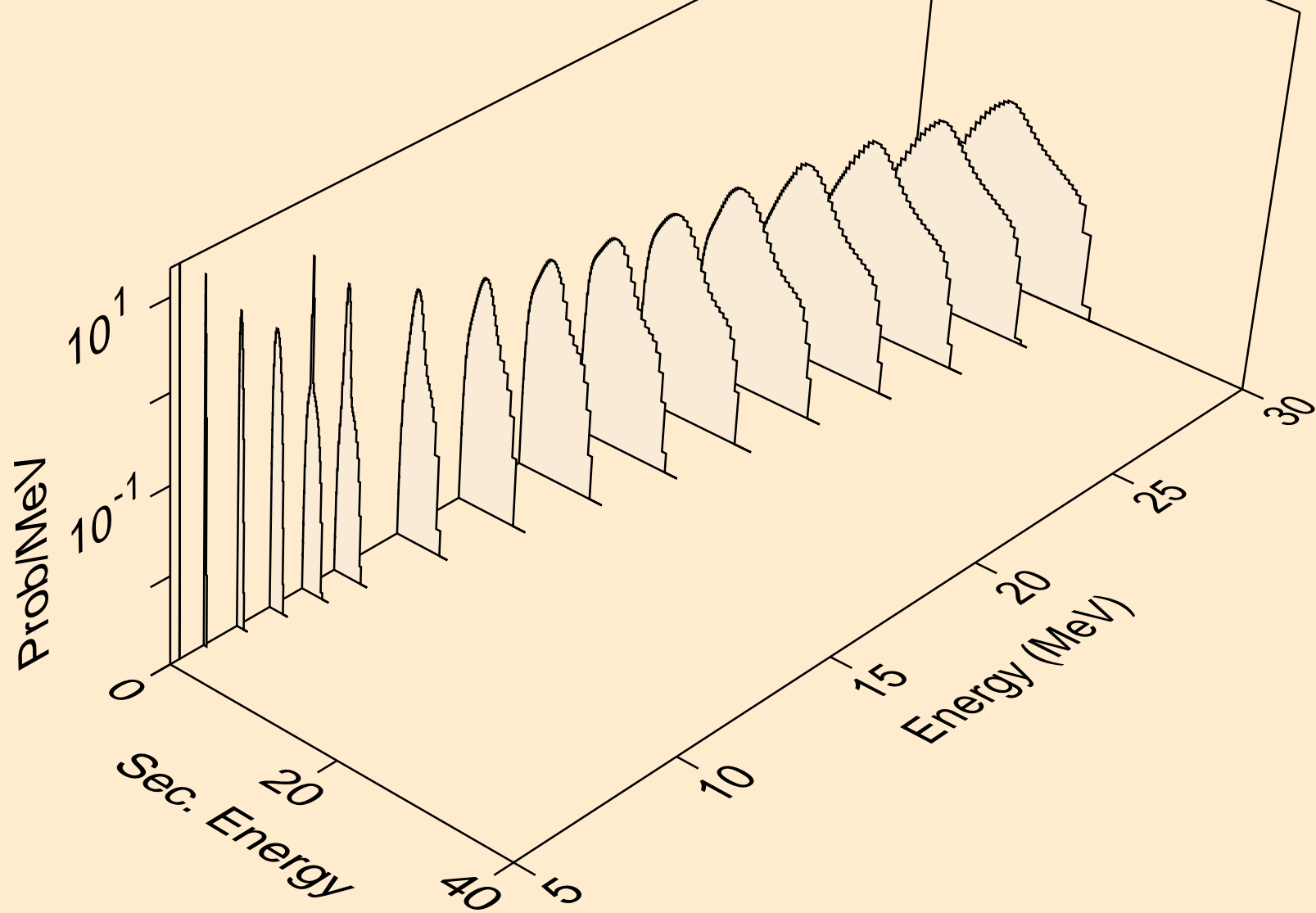

KR073 HELION ACER TENDL-2024 LIBRARY; T=0.K  
neutrons from (s,n\*)2a

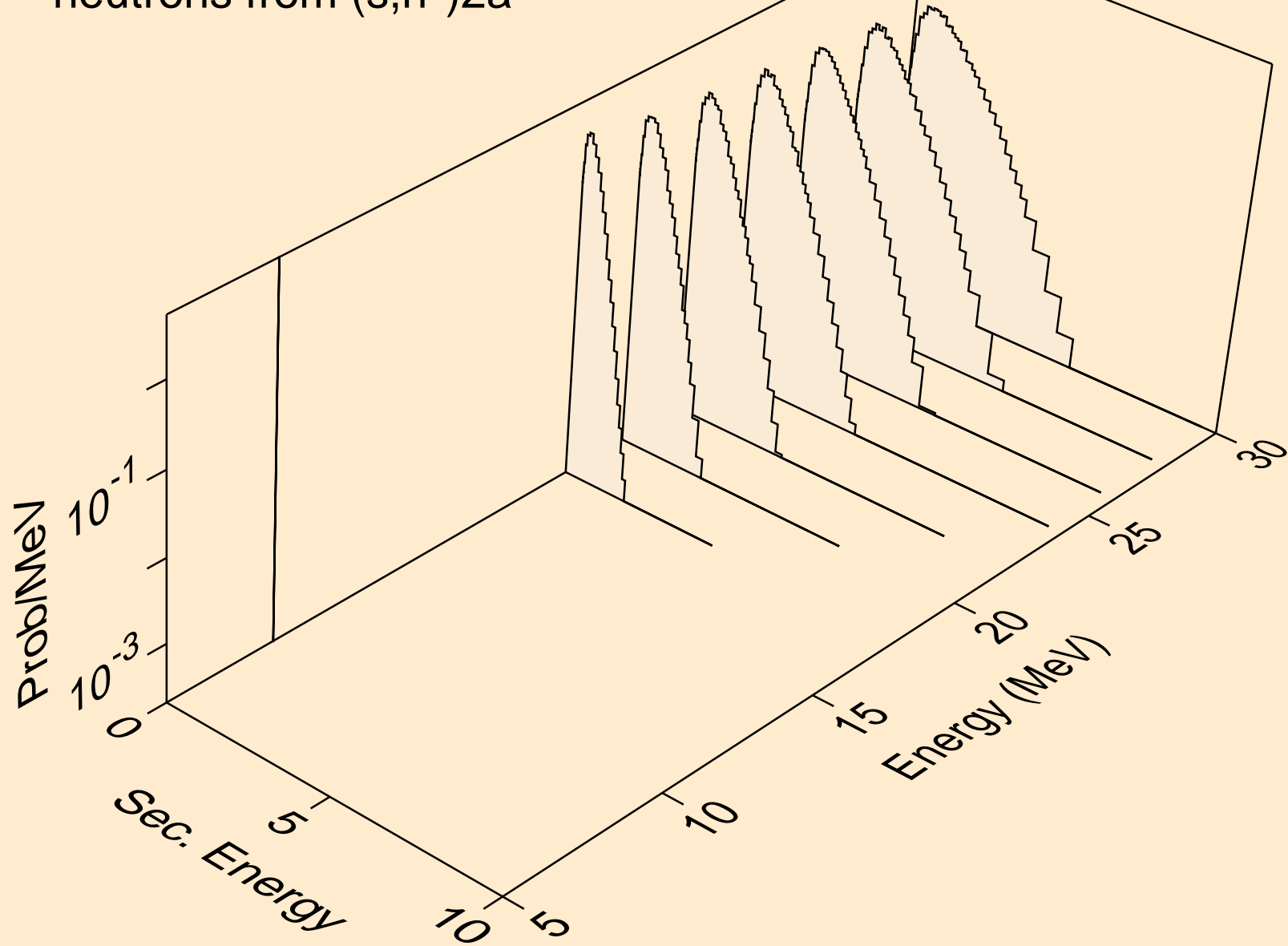

KR073 HELION ACER TENDL-2024 LIBRARY; T=0.K  
neutrons from (s,n\*)d

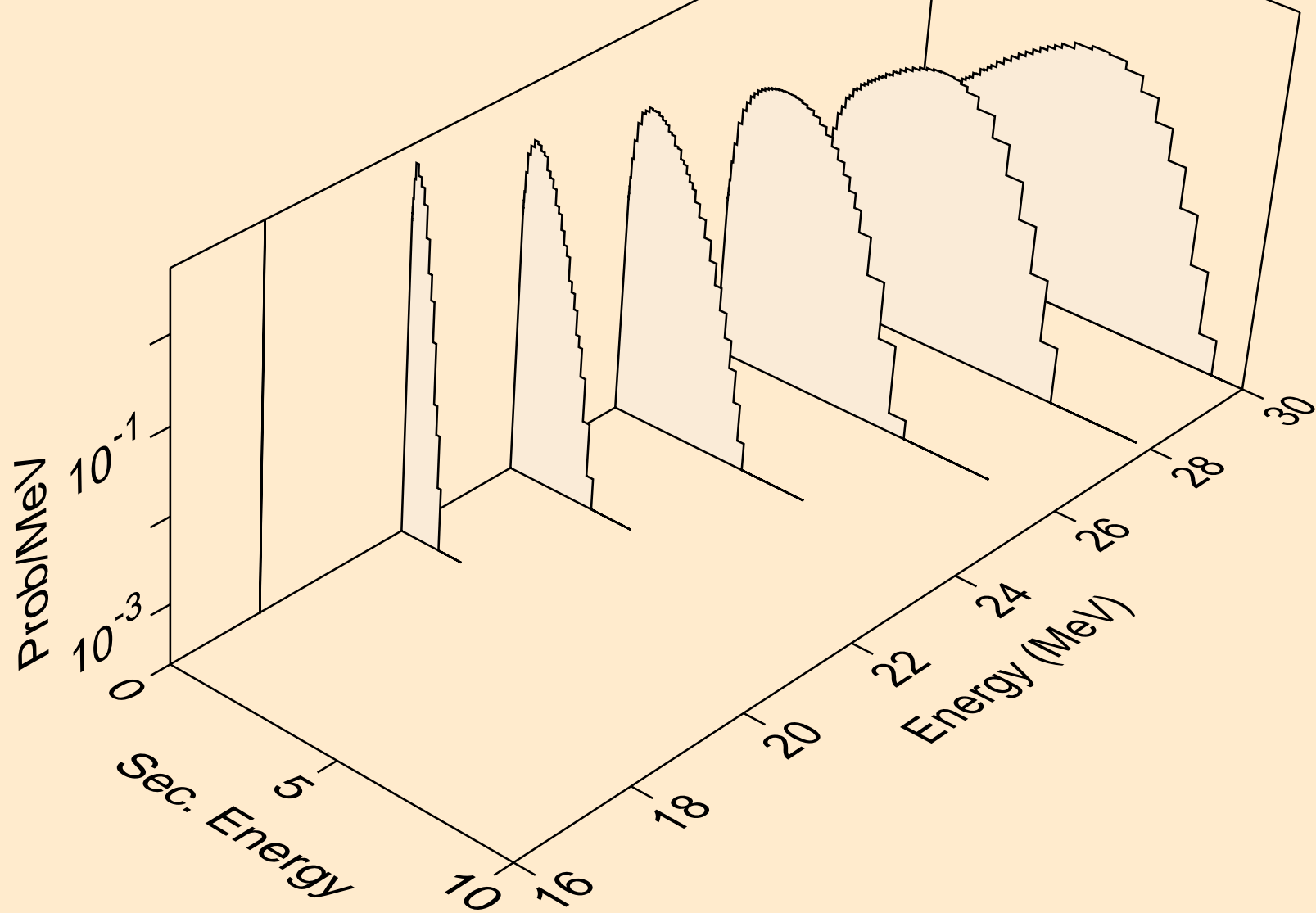

KR073 HELION ACER TENDL-2024 LIBRARY; T=0.K  
neutrons from (s,n\*)he3

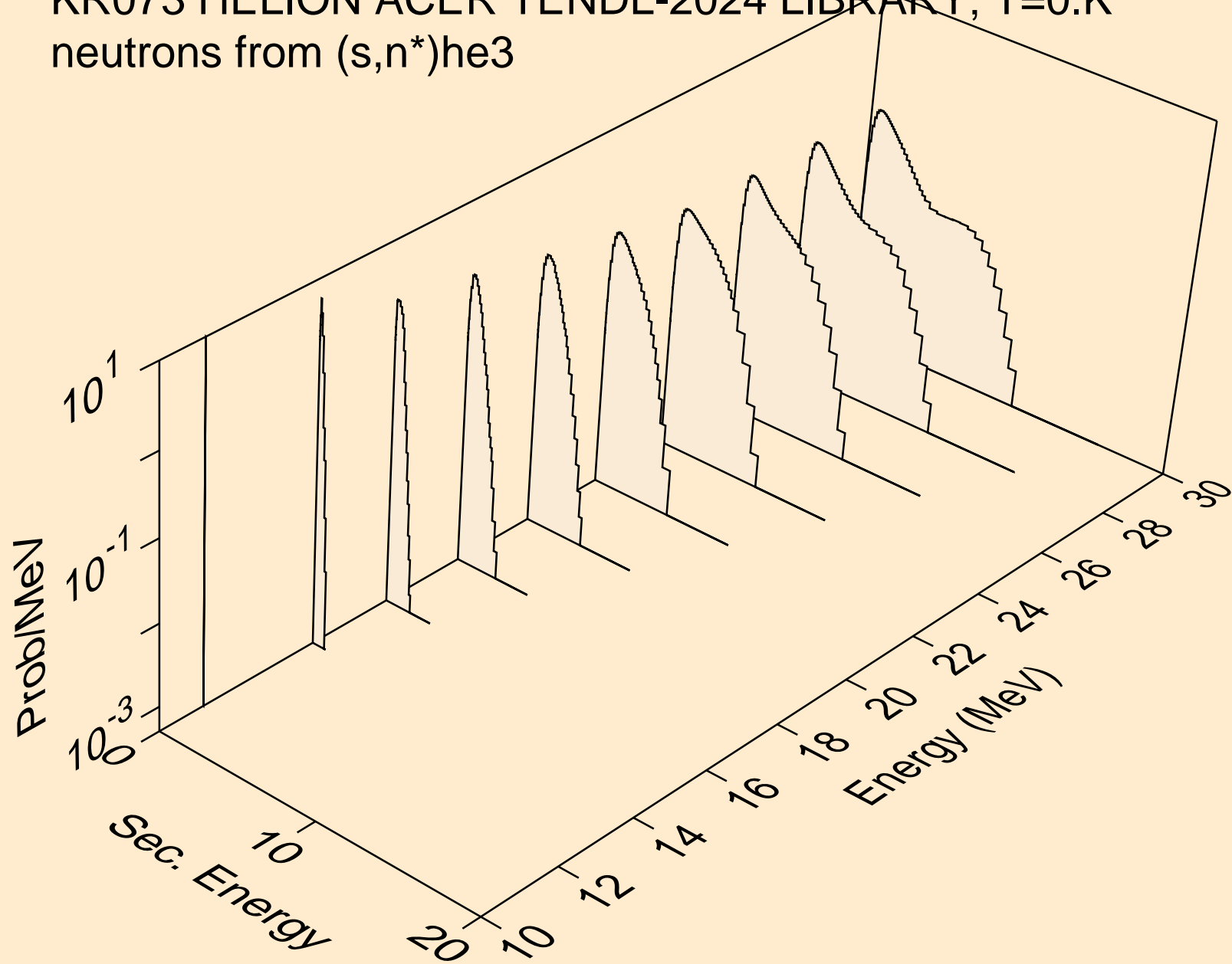

KR073 HELION ACER TENDL-2024 LIBRARY; T=0.K  
neutrons from (s,2np)

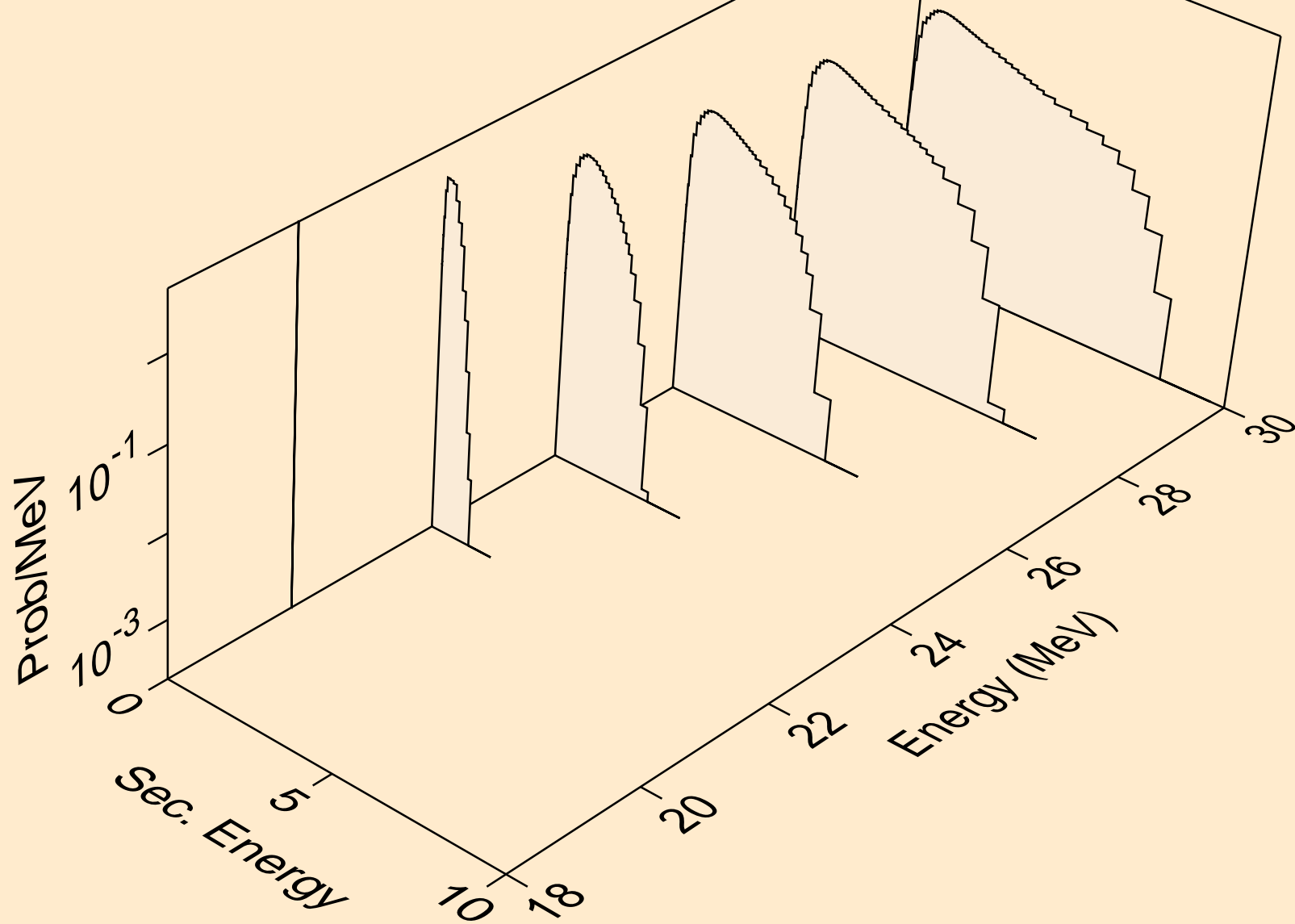

KR073 HELION ACER TENDL-2024 LIBRARY; T=0.K  
neutrons from (s,n2p)

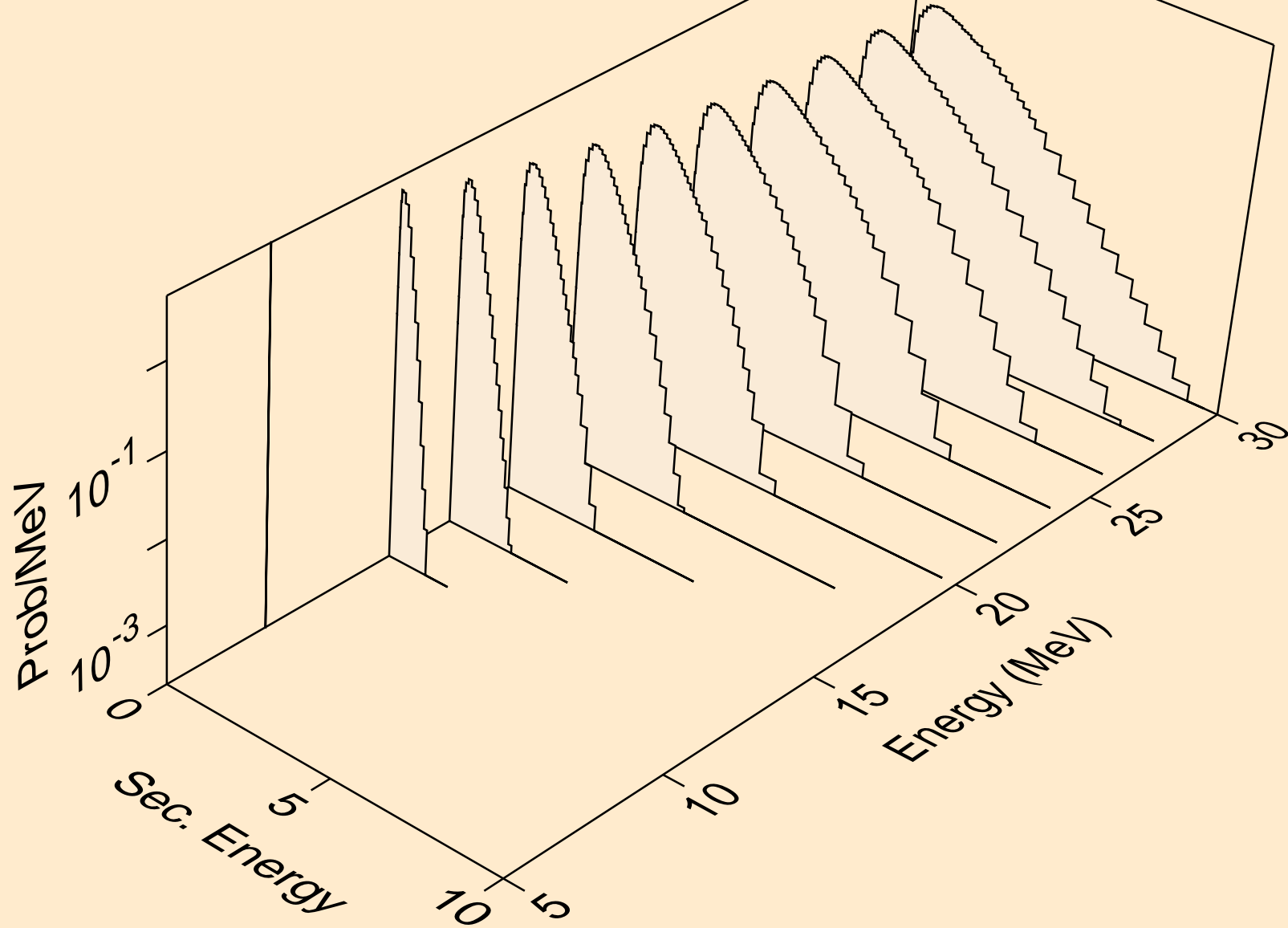

KR073 HELION ACER TENDL-2024 LIBRARY; T=0.K  
neutrons from (s,npa)

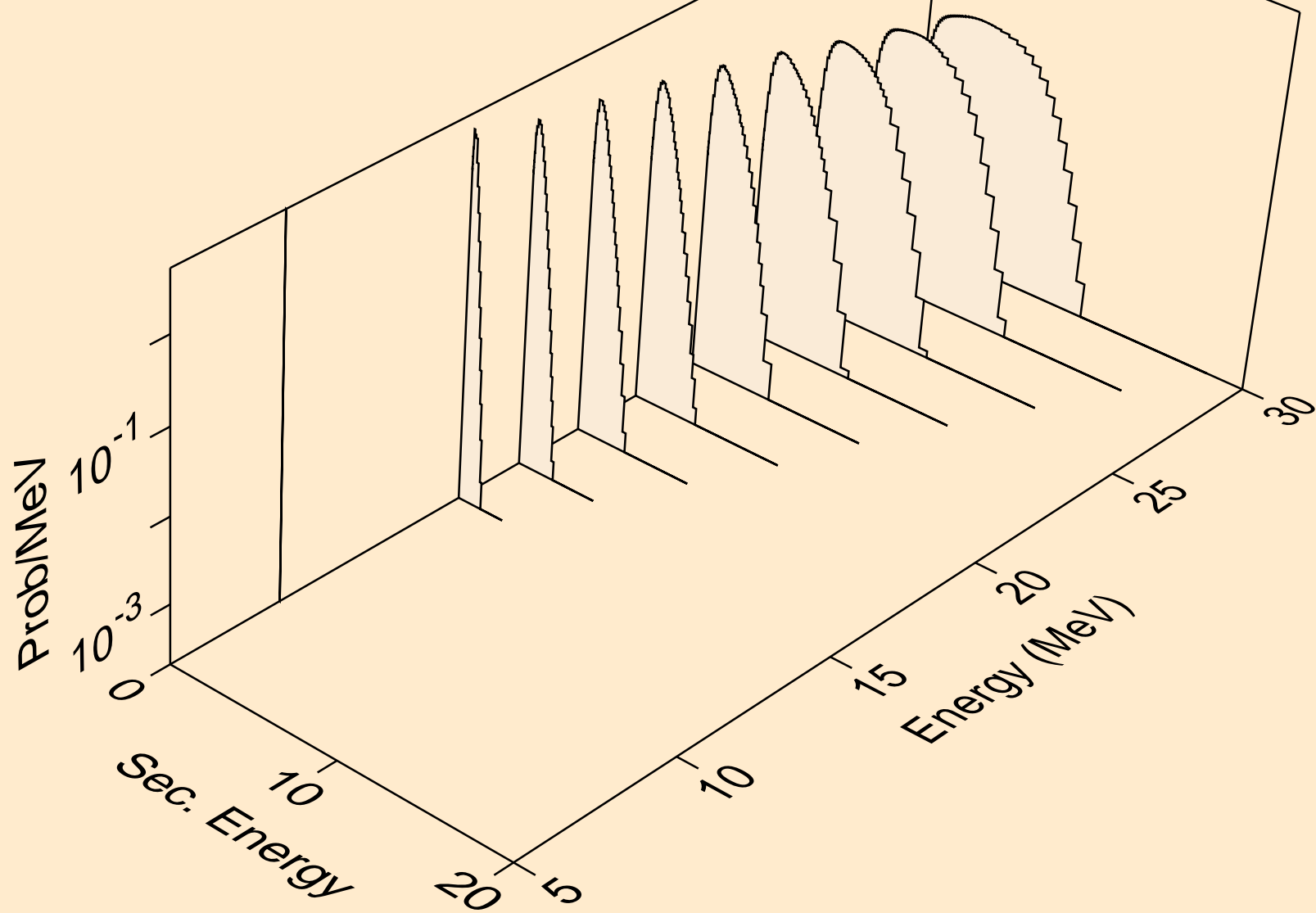

KR073 HELION ACER TENDL-2024 LIBRARY; T=0.K  
protons from (s,x)

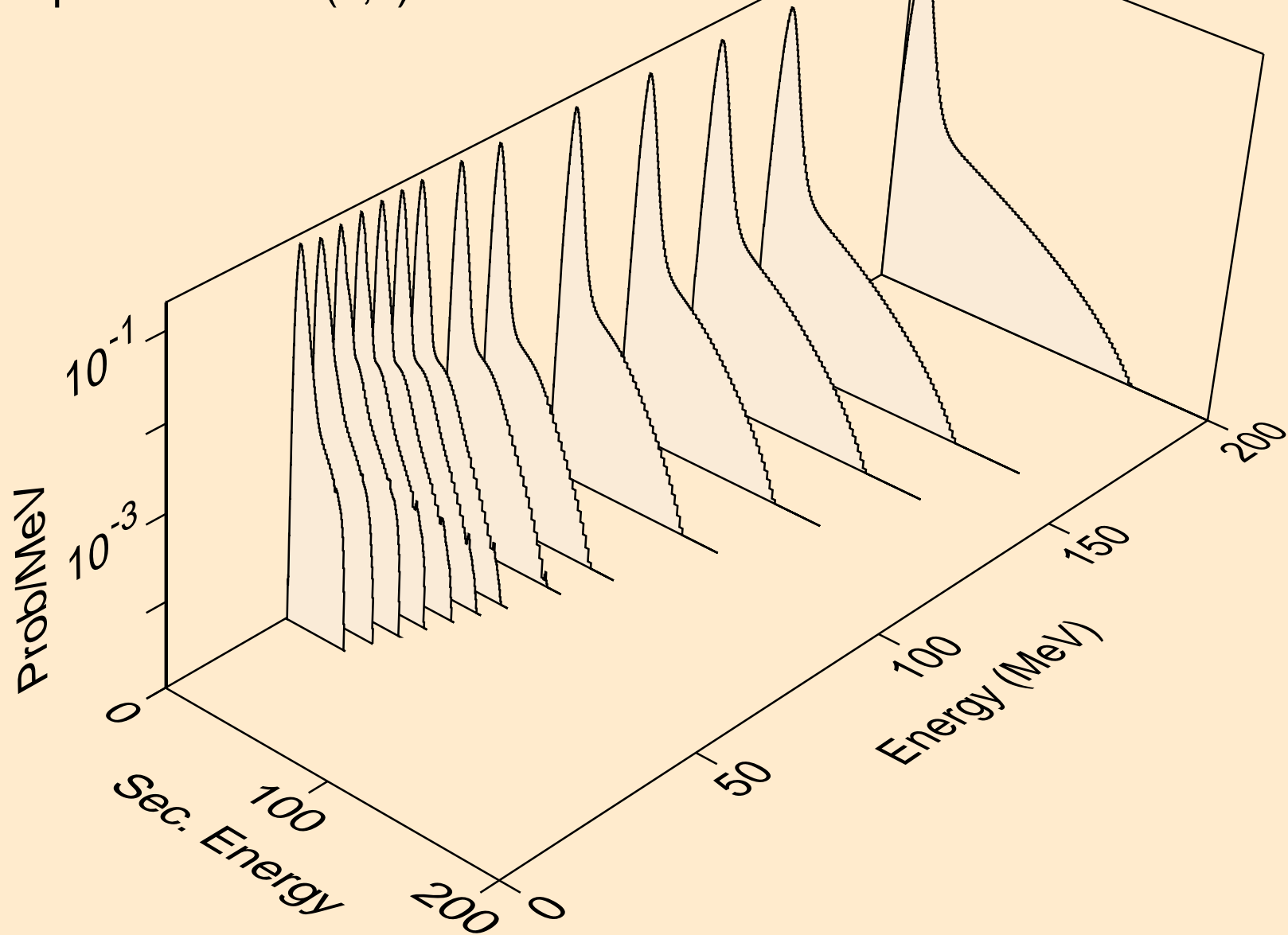

KR073 HELION ACER TENDL-2024 LIBRARY; T=0.K  
protons from (s,n\*)p

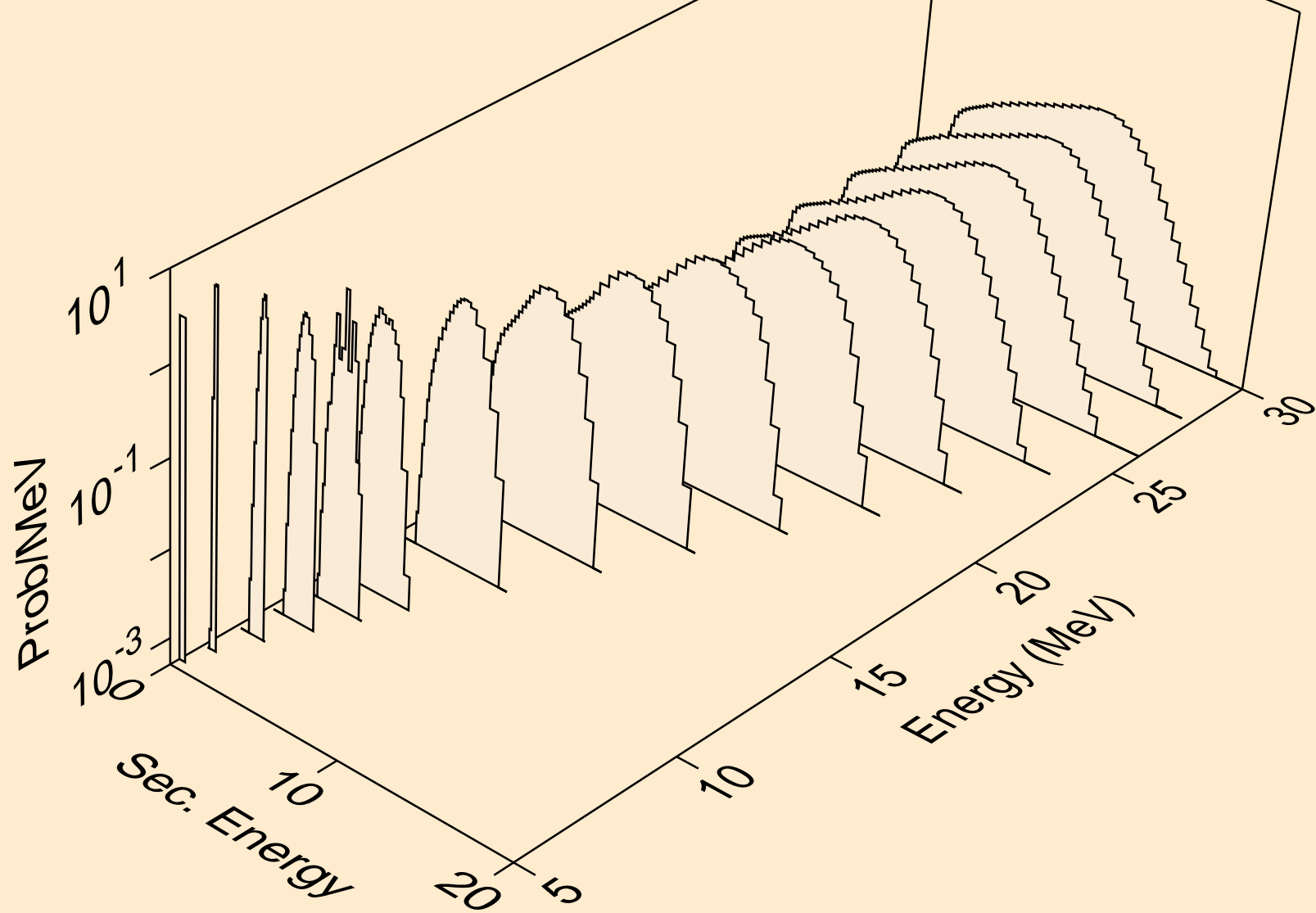

KR073 HELION ACER TENDL-2024 LIBRARY; T=0.K  
protons from (s,2np)

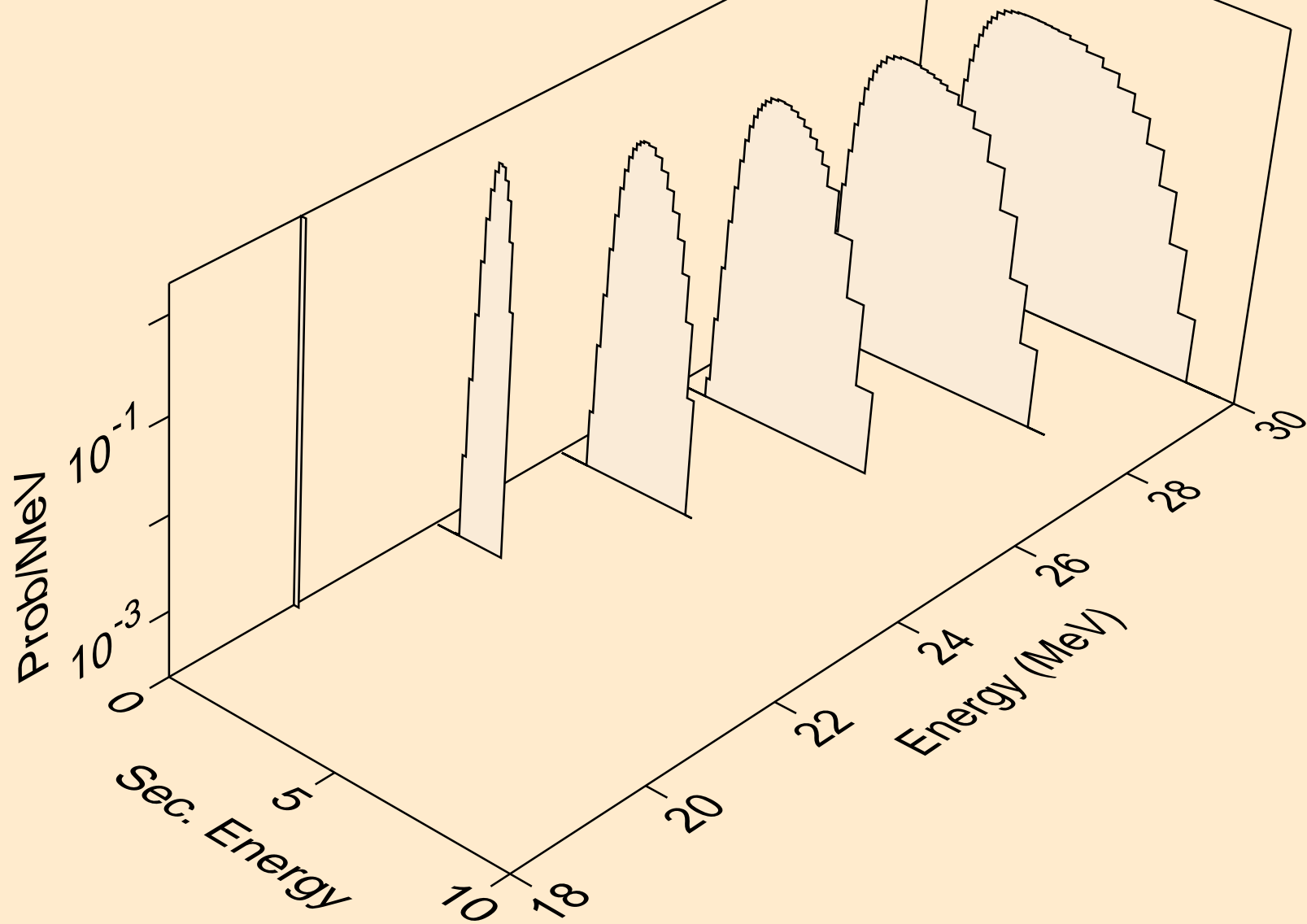

KR073 HELION ACER TENDL-2024 LIBRARY; T=0.K  
protons from (s,n2p)

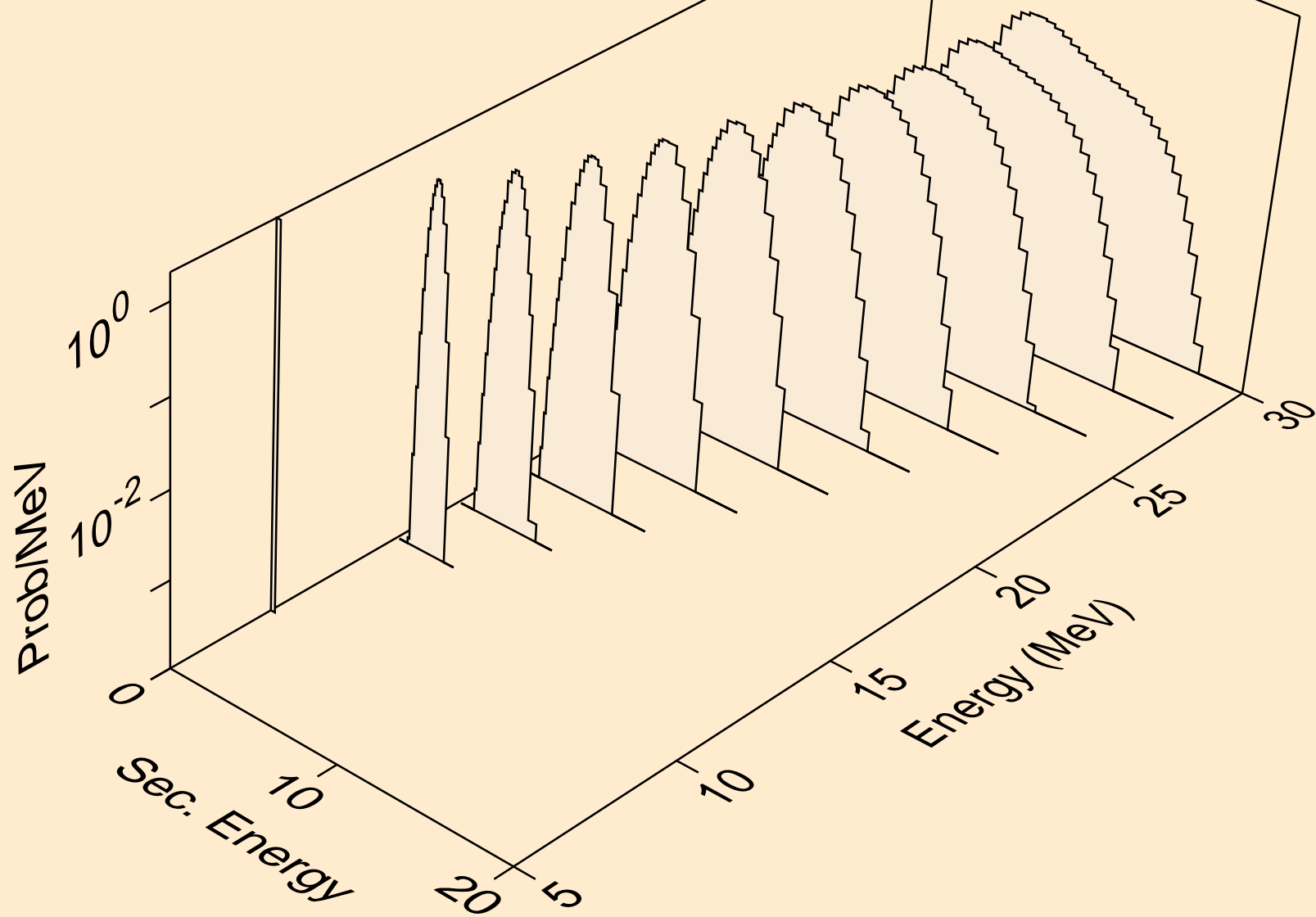

KR073 HELION ACER TENDL-2024 LIBRARY; T=0.K  
protons from (s,npa)

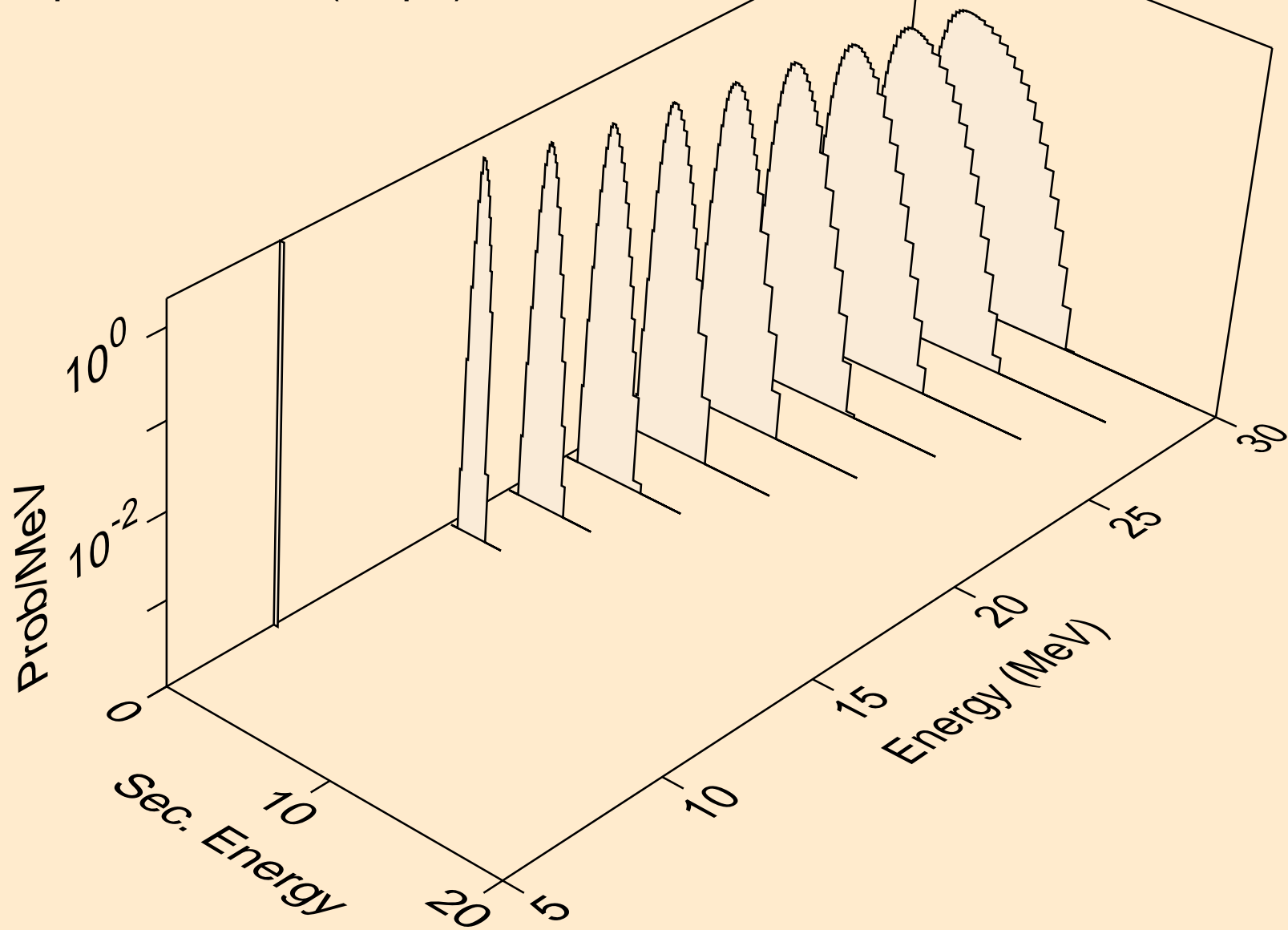

KR073 HELION ACER TENDL-2024 LIBRARY; T=0.K  
protons from (s,p)

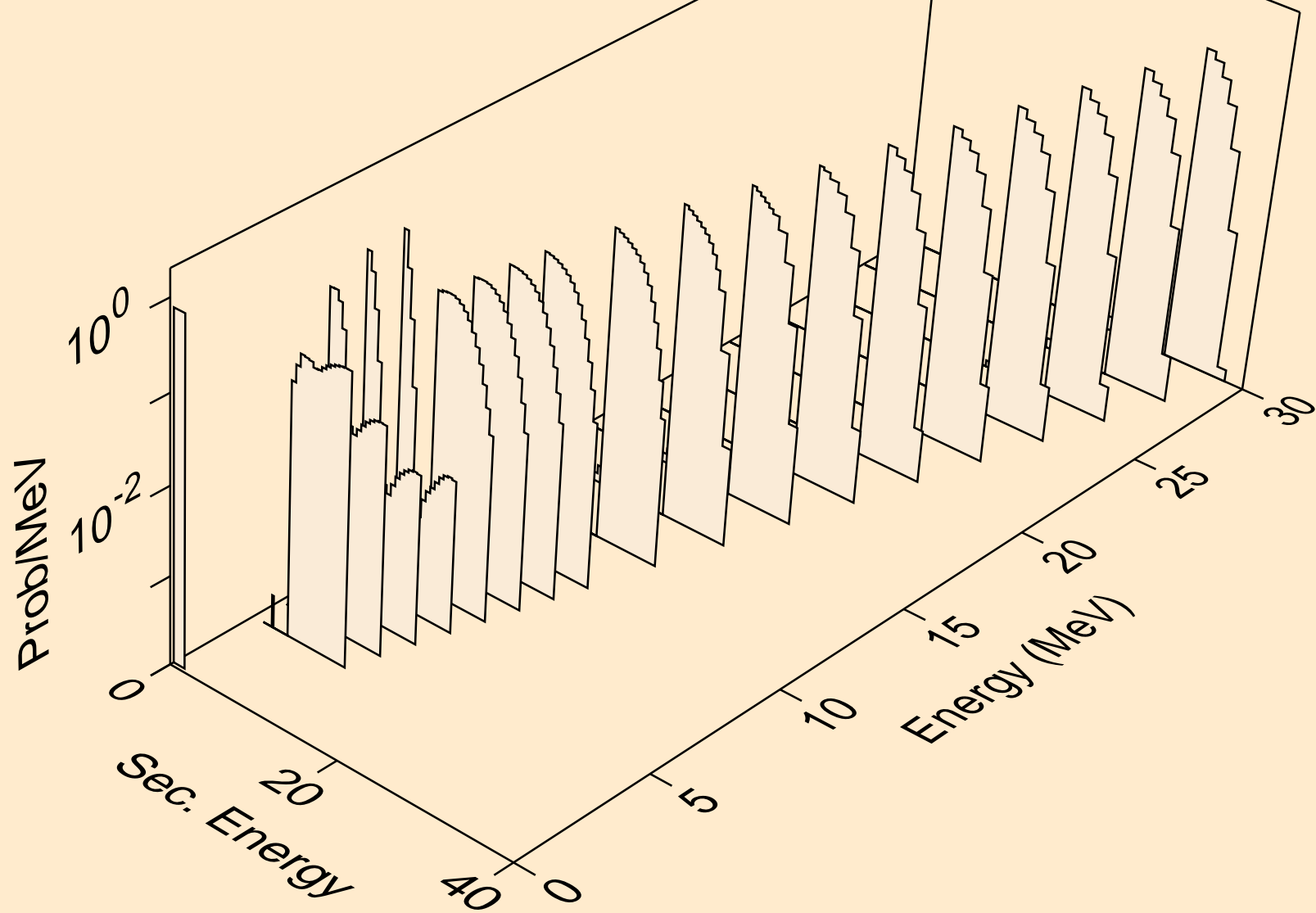

KR073 HELION ACER TENDL-2024 LIBRARY; T=0.K  
protons from (s,2p)

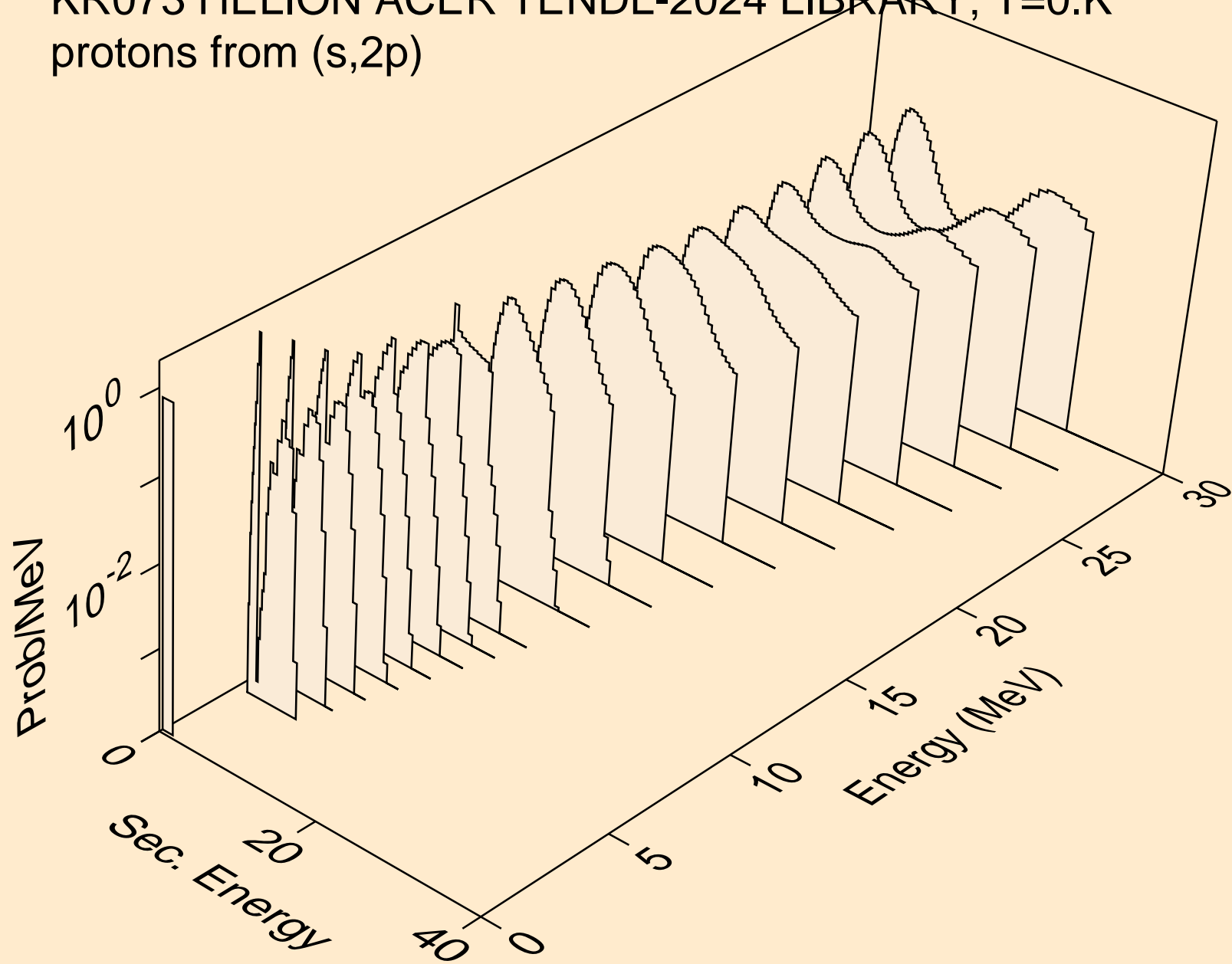

KR073 HELION ACER TENDL-2024 LIBRARY; T=0.K  
protons from (s,pa)

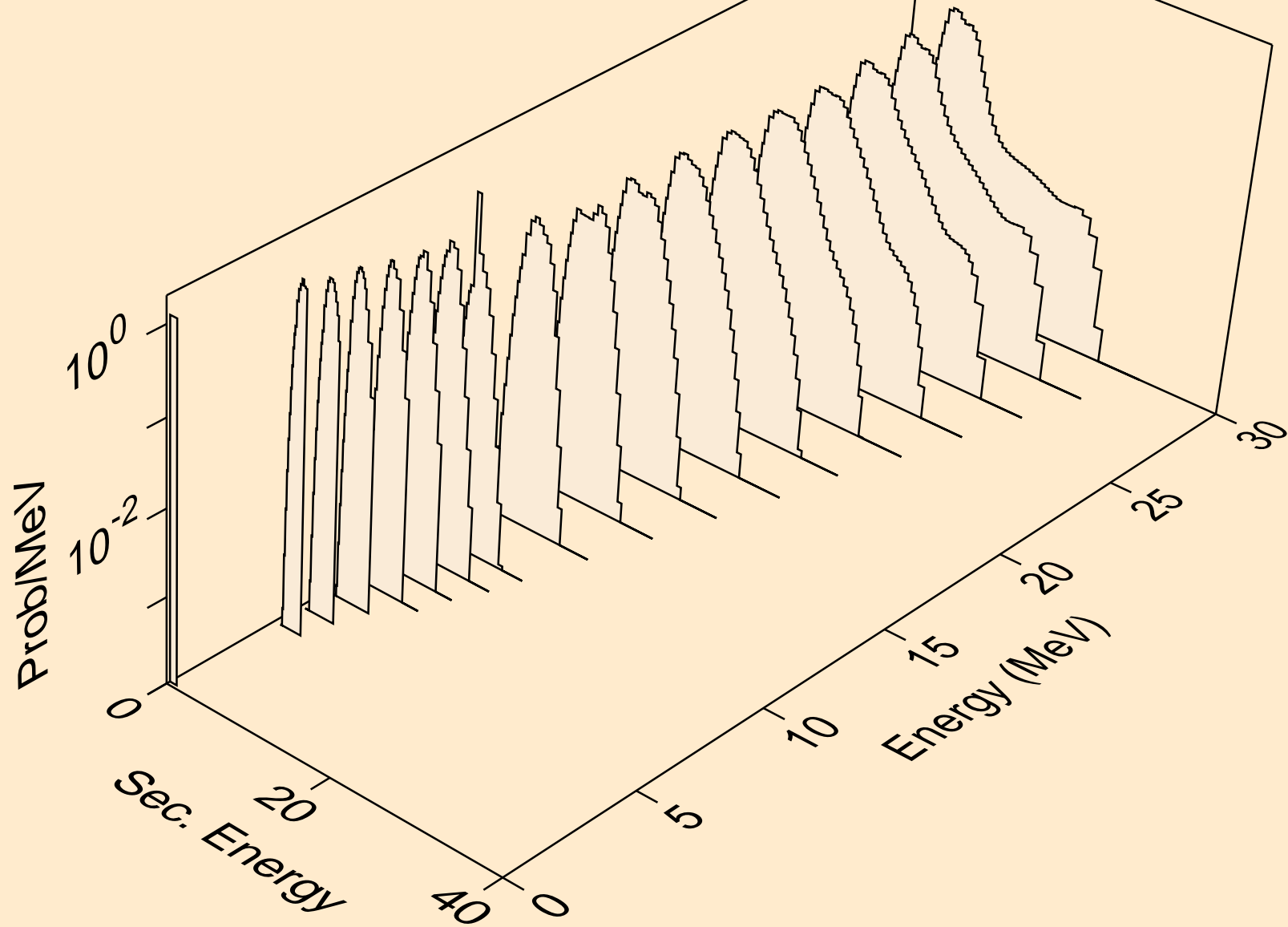

KR073 HELION ACER TENDL-2024 LIBRARY; T=0.K  
protons from (s,pd)

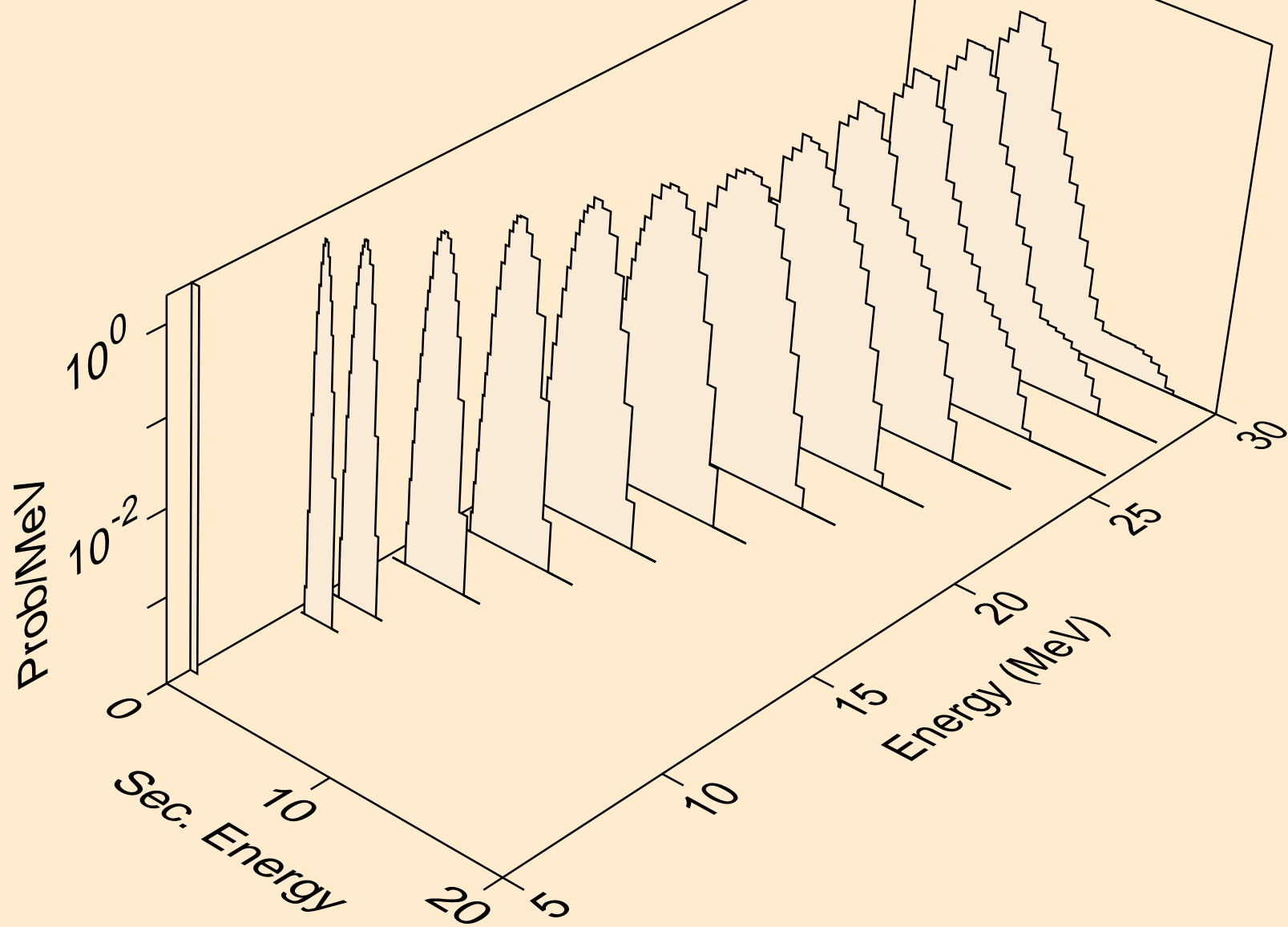

KR073 HELION ACER TENDL-2024 LIBRARY; T=0.K  
protons from (s,pt)

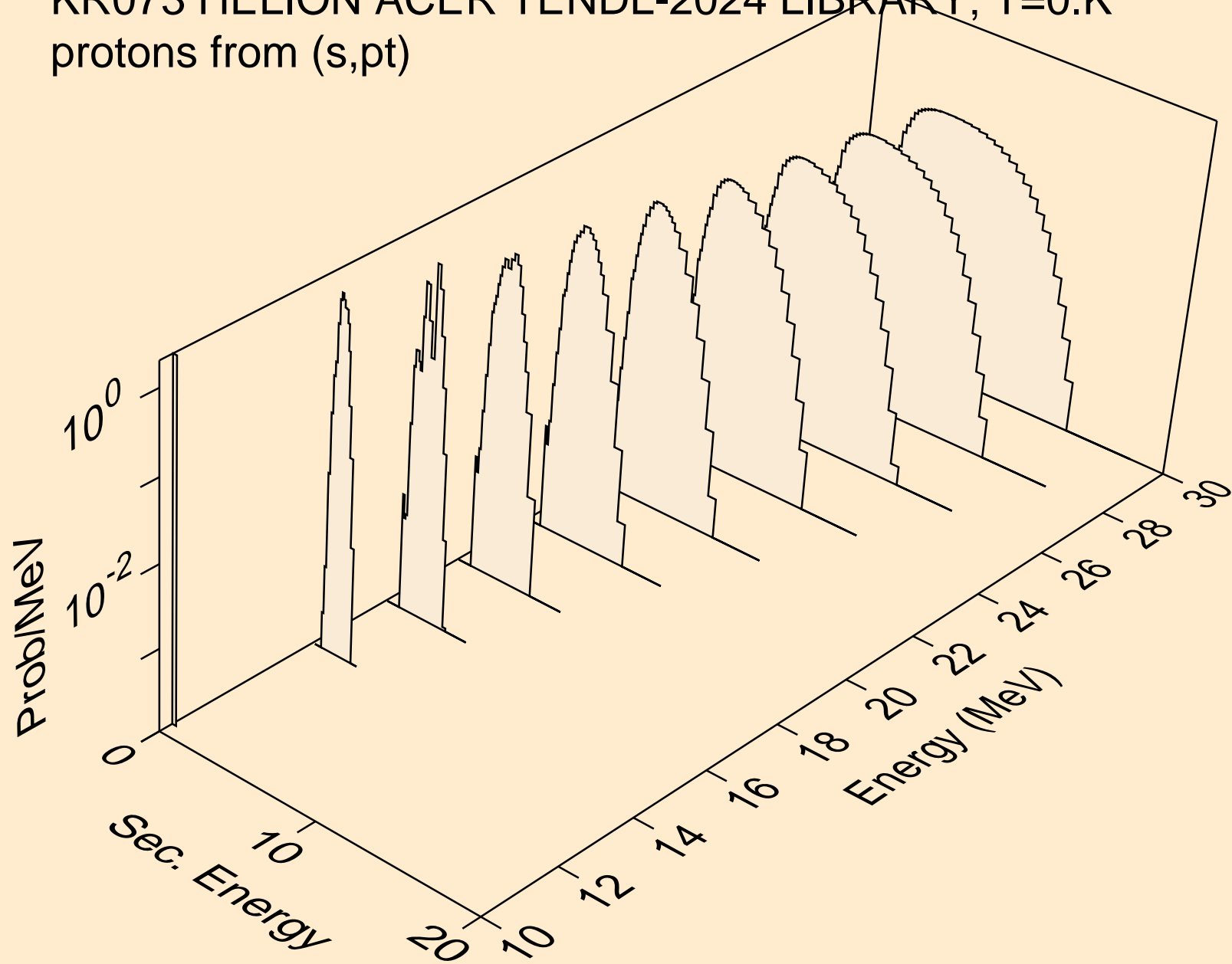

KR073 HELION ACER TENDL-2024 LIBRARY; T=0.K  
deuterons from (s,x)

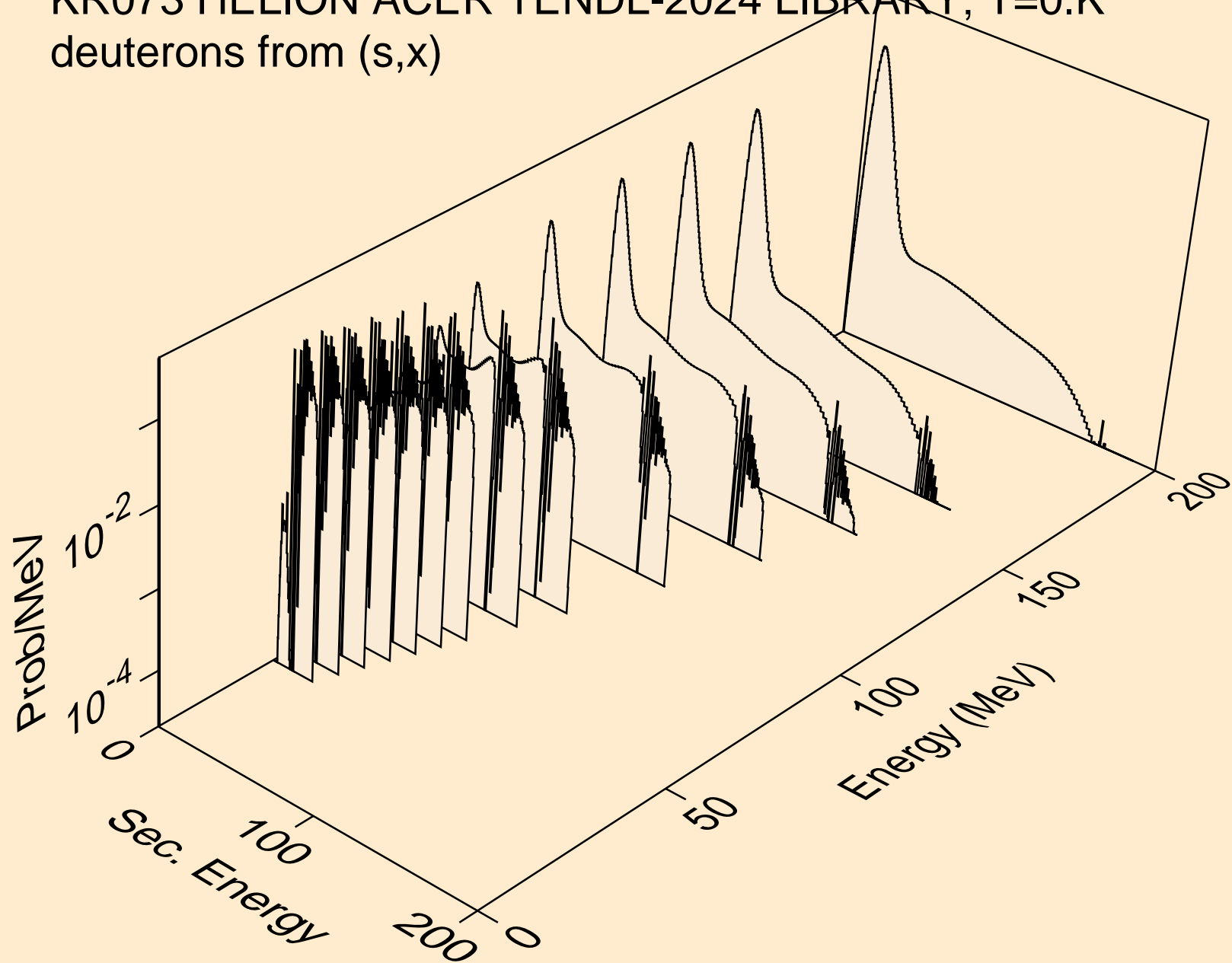

KR073 HELION ACER TENDL-2024 LIBRARY; T=0.K  
deuterons from (s,n\*)d

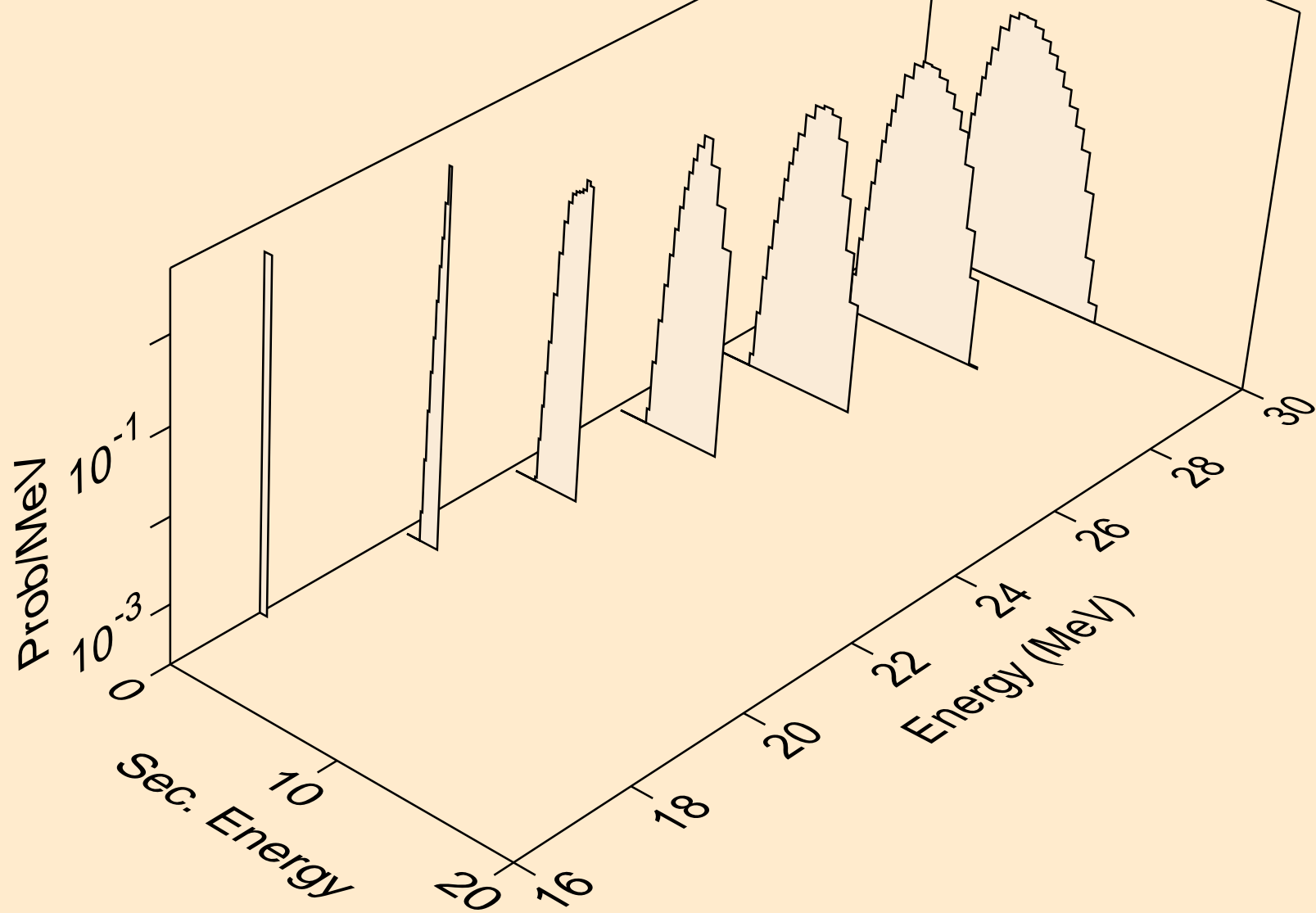

KR073 HELION ACER TENDL-2024 LIBRARY; T=0.K  
deuterons from (s,d)

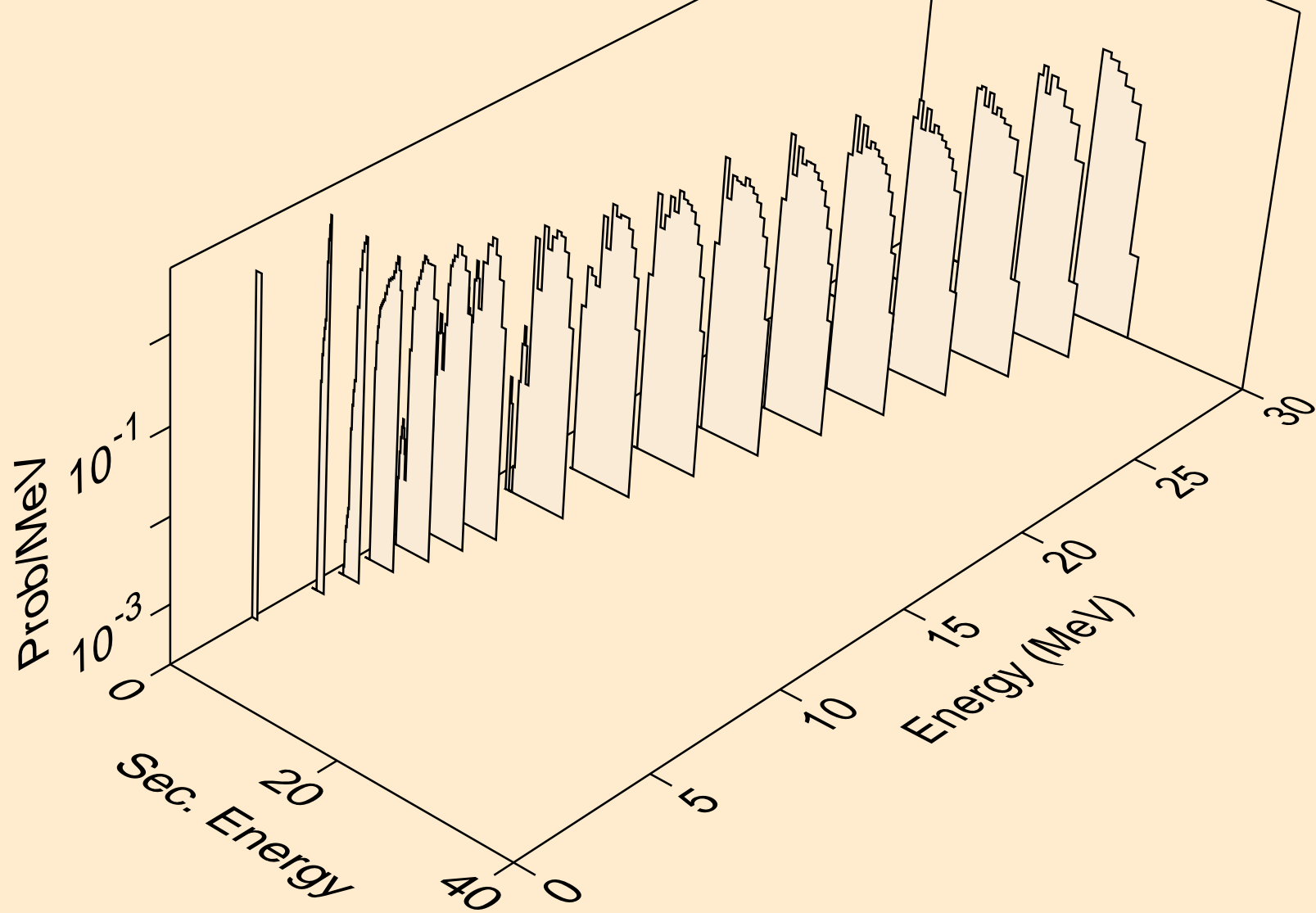

KR073 HELION ACER TENDL-2024 LIBRARY; T=0.K  
deuterons from (s,pd)

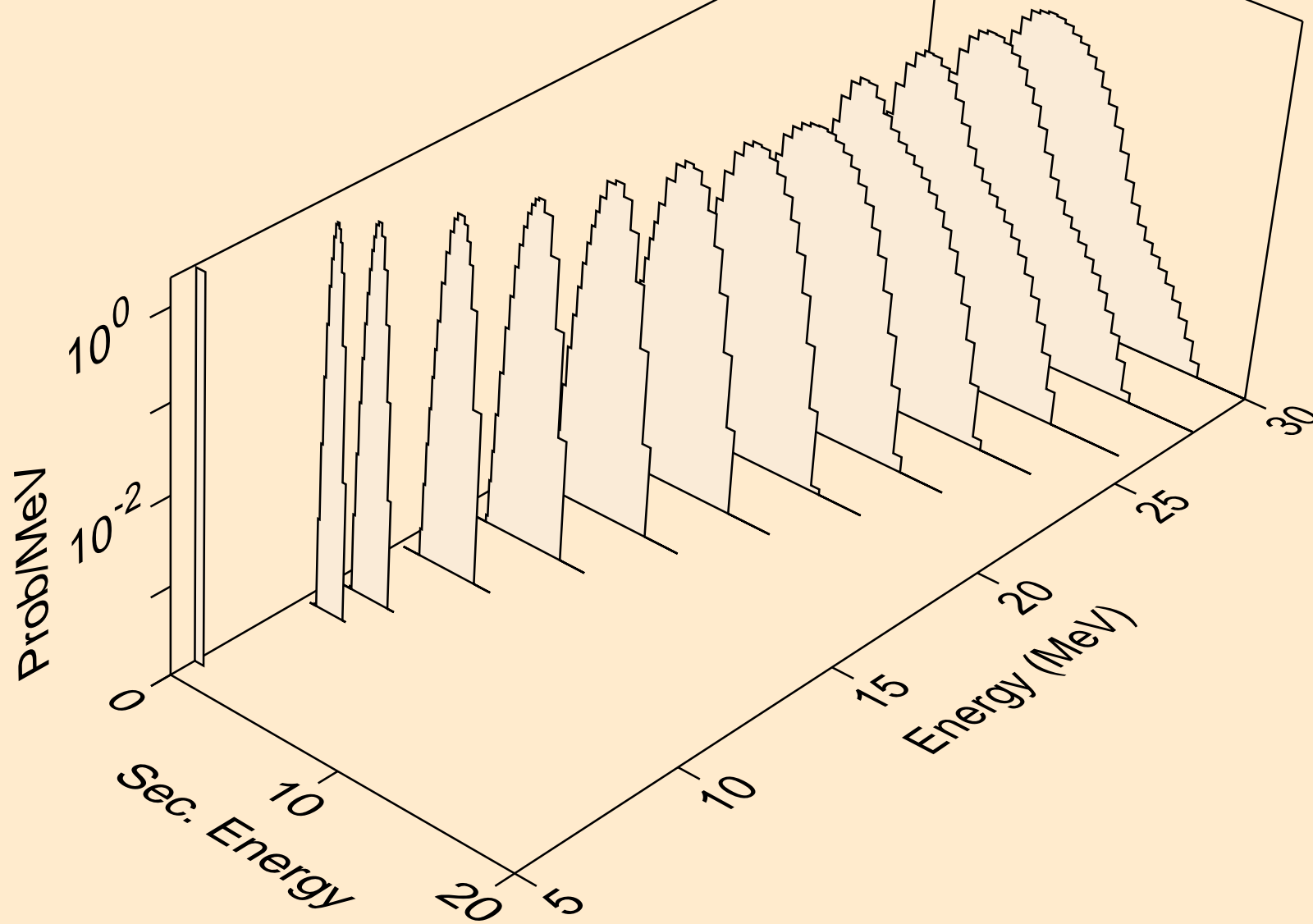

KR073 HELION ACER TENDL-2024 LIBRARY; T=0.K  
deuterons from (s,da)

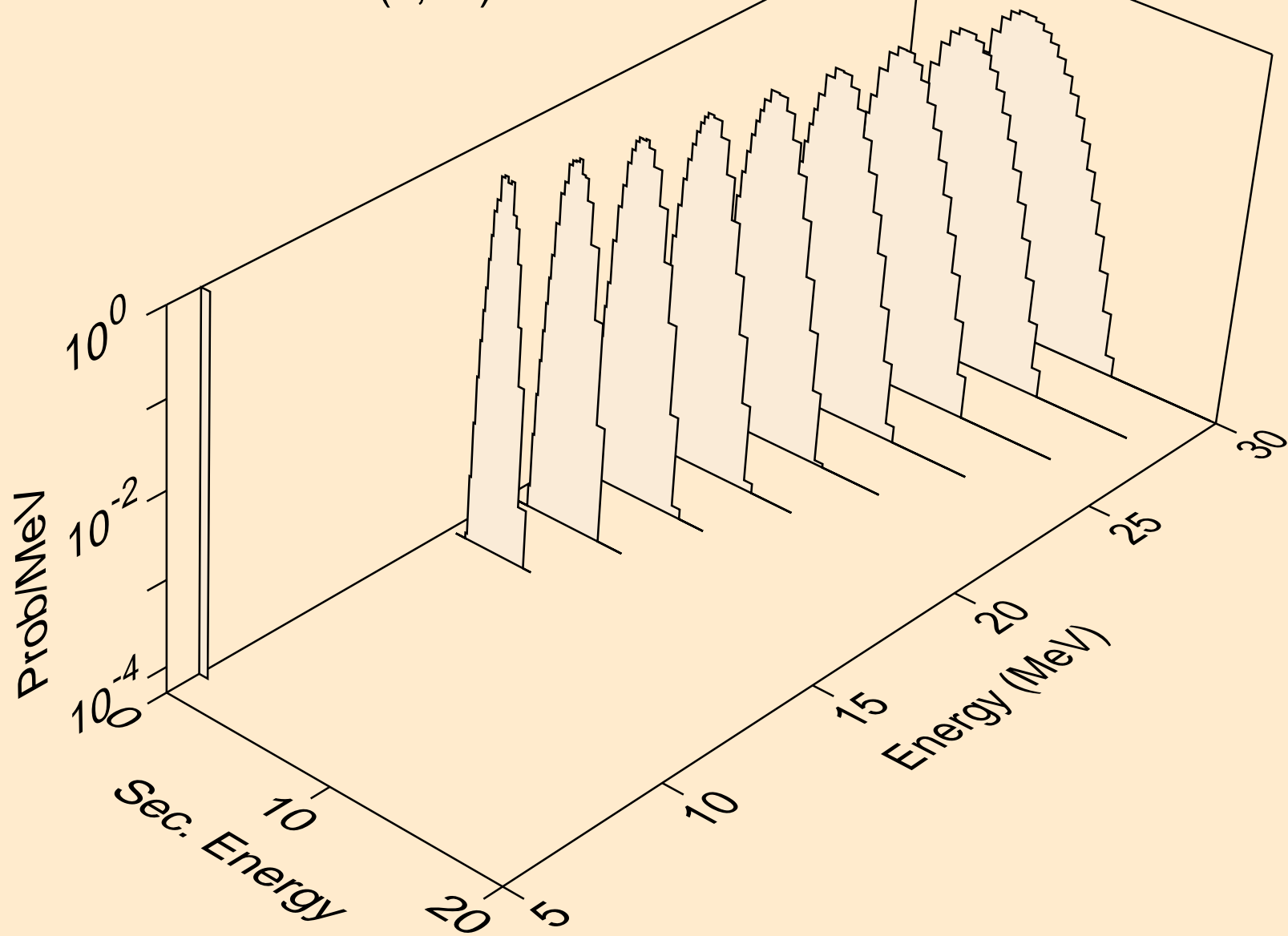

KR073 HELION ACER TENDL-2024 LIBRARY; T=0.K  
tritons from (s,x)

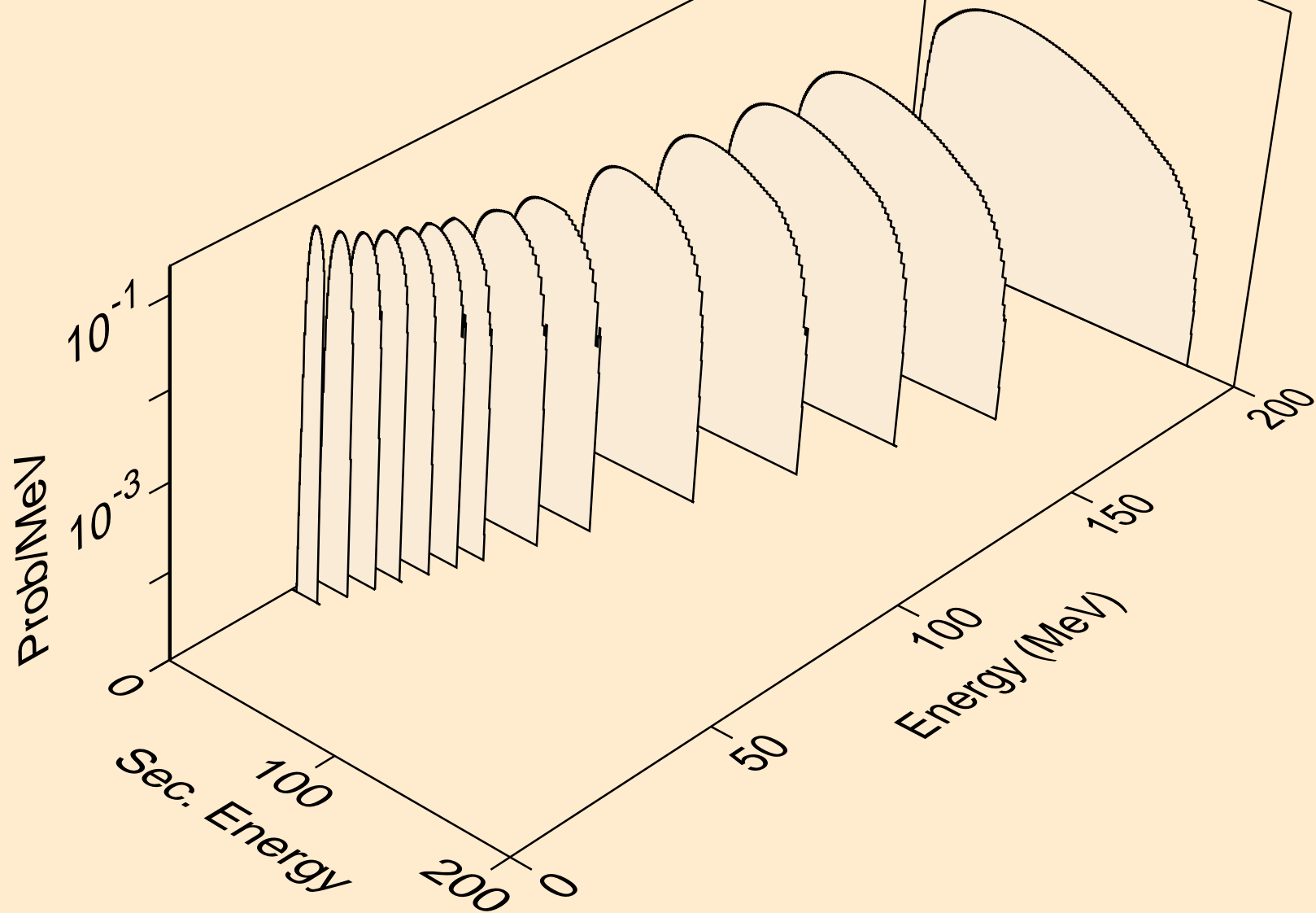

KR073 HELION ACER TENDL-2024 LIBRARY; T=0.K  
tritons from (s,t)

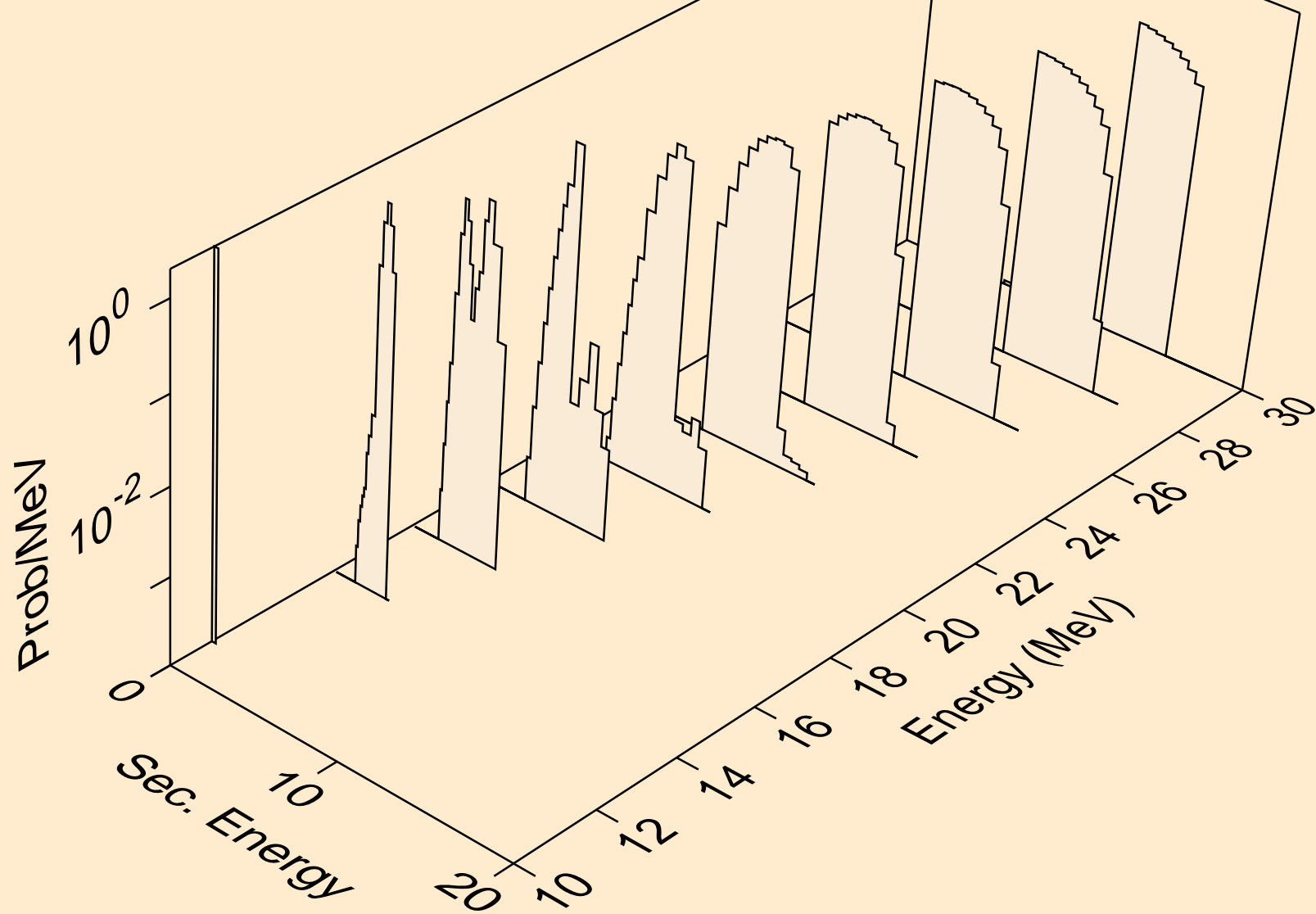

KR073 HELION ACER TENDL-2024 LIBRARY; T=0.K  
tritons from (s,pt)

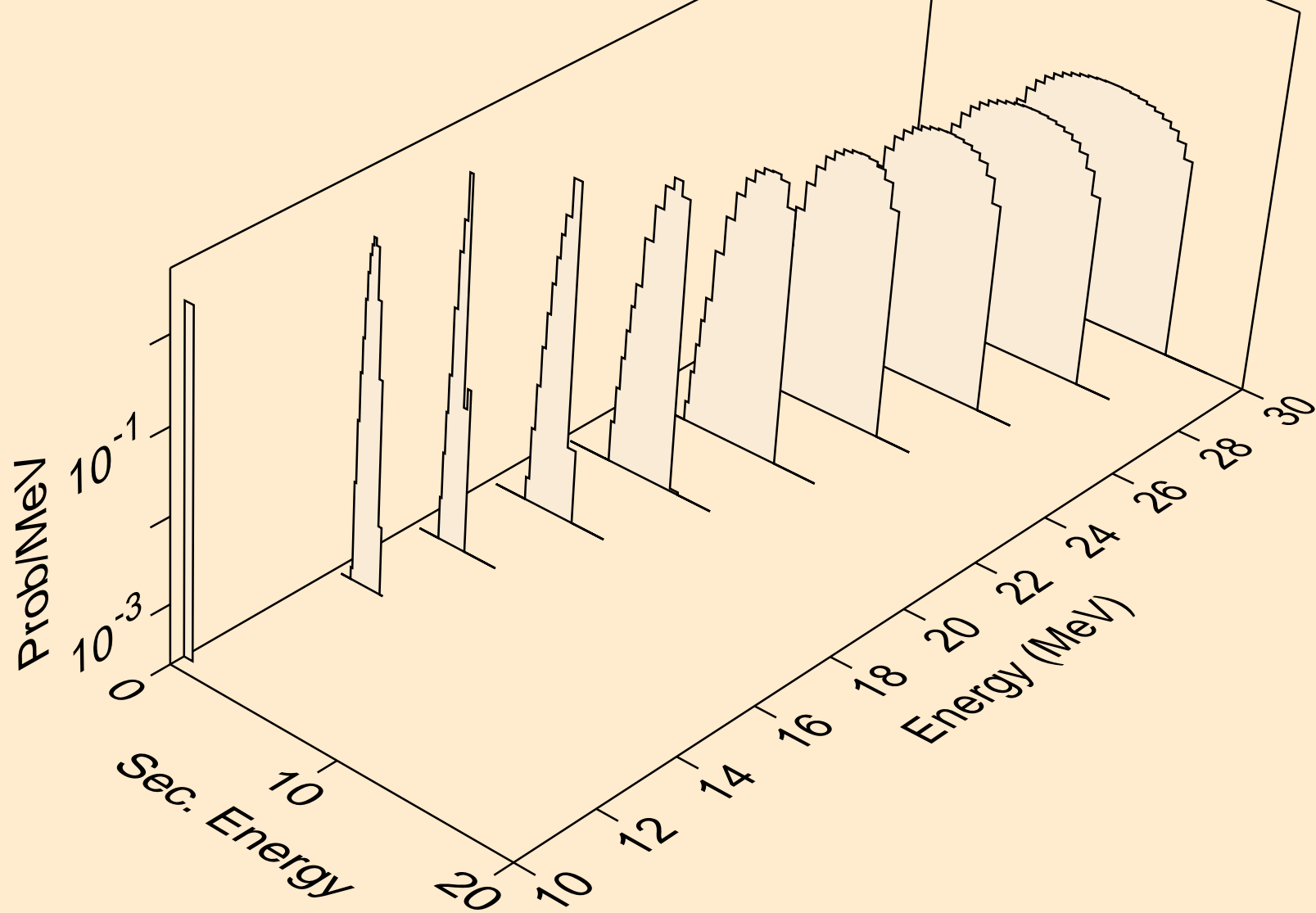

KR073 HELION ACER TENDL-2024 LIBRARY; T=0.K  
alphas from (s,x)

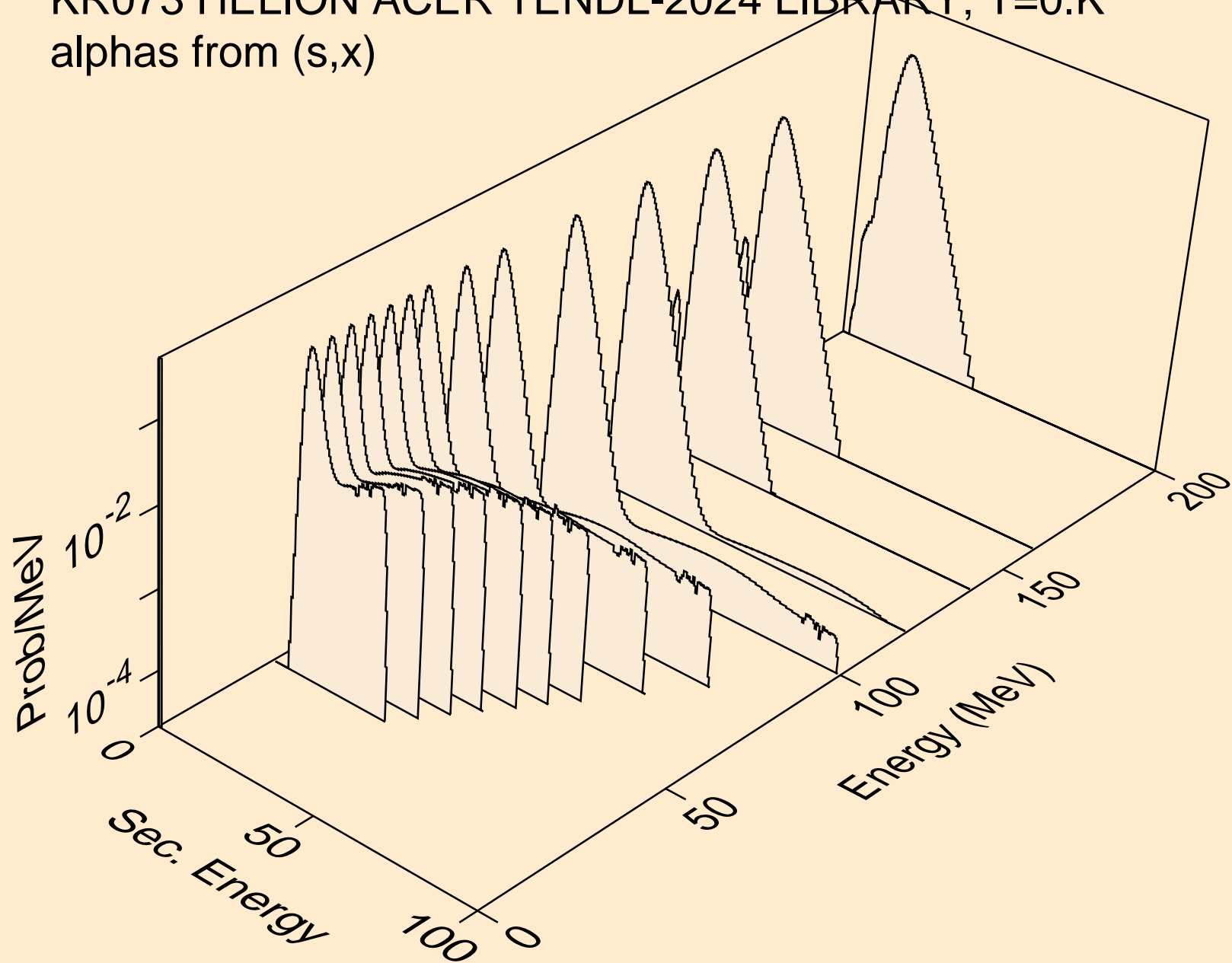

KR073 HELION ACER TENDL-2024 LIBRARY; T=0.K  
alphas from (s,n\*)a

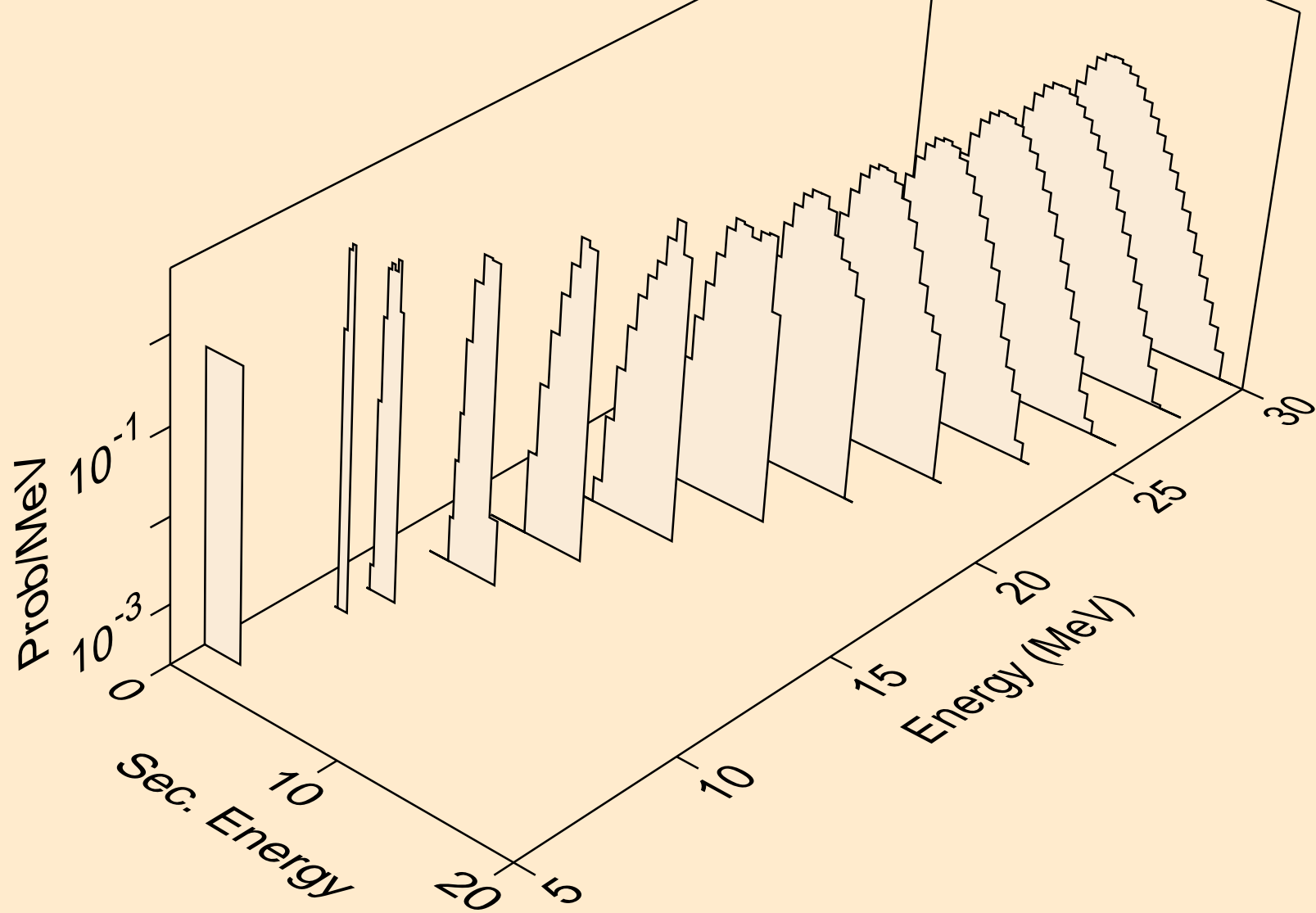

KR073 HELION ACER TENDL-2024 LIBRARY; T=0.K  
alphas from (s,2n)a

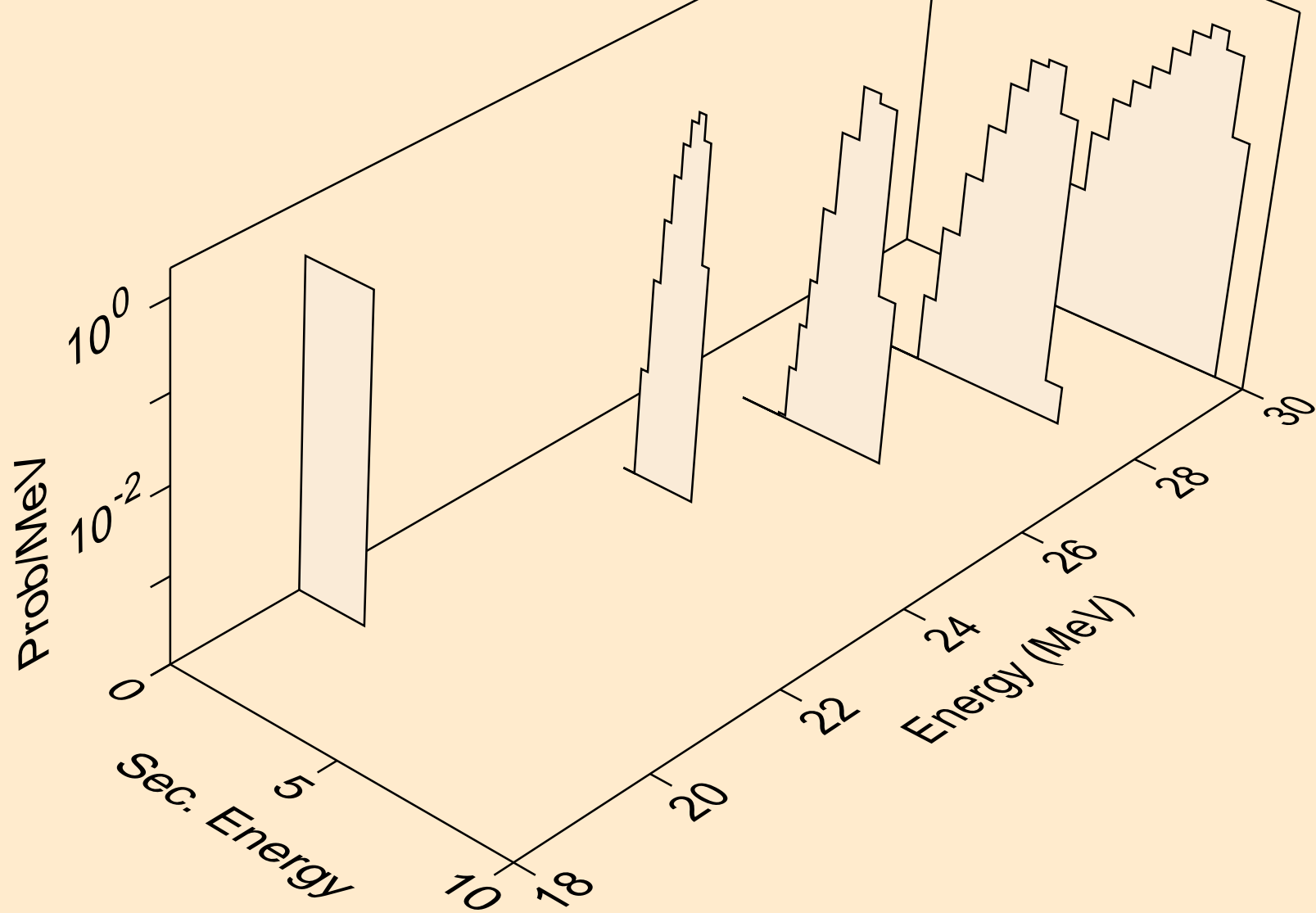

KR073 HELION ACER TENDL-2024 LIBRARY; T=0.K  
alphas from (s,n\*)2a

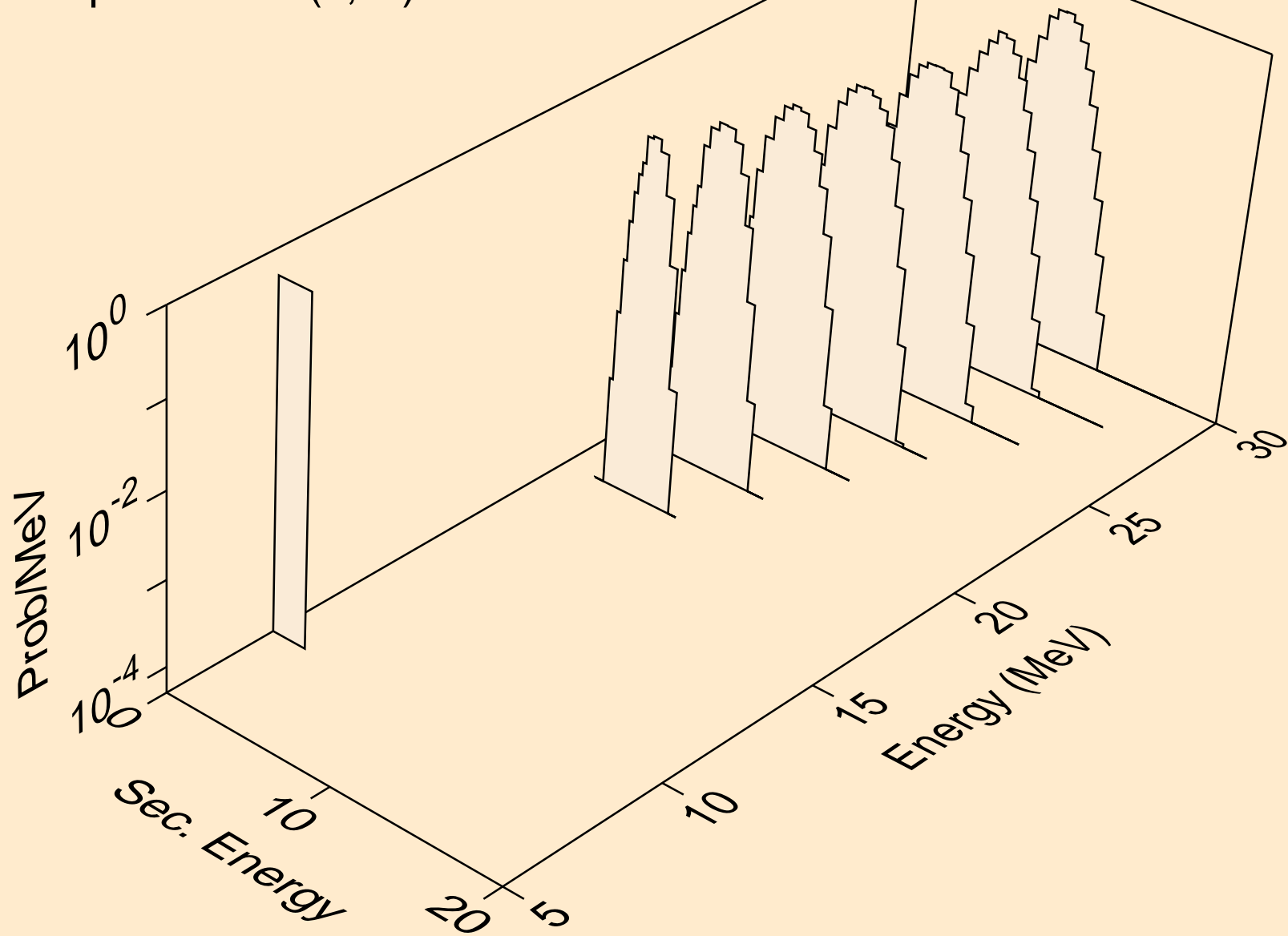

KR073 HELION ACER TENDL-2024 LIBRARY; T=0.K  
alphas from (s,npa)

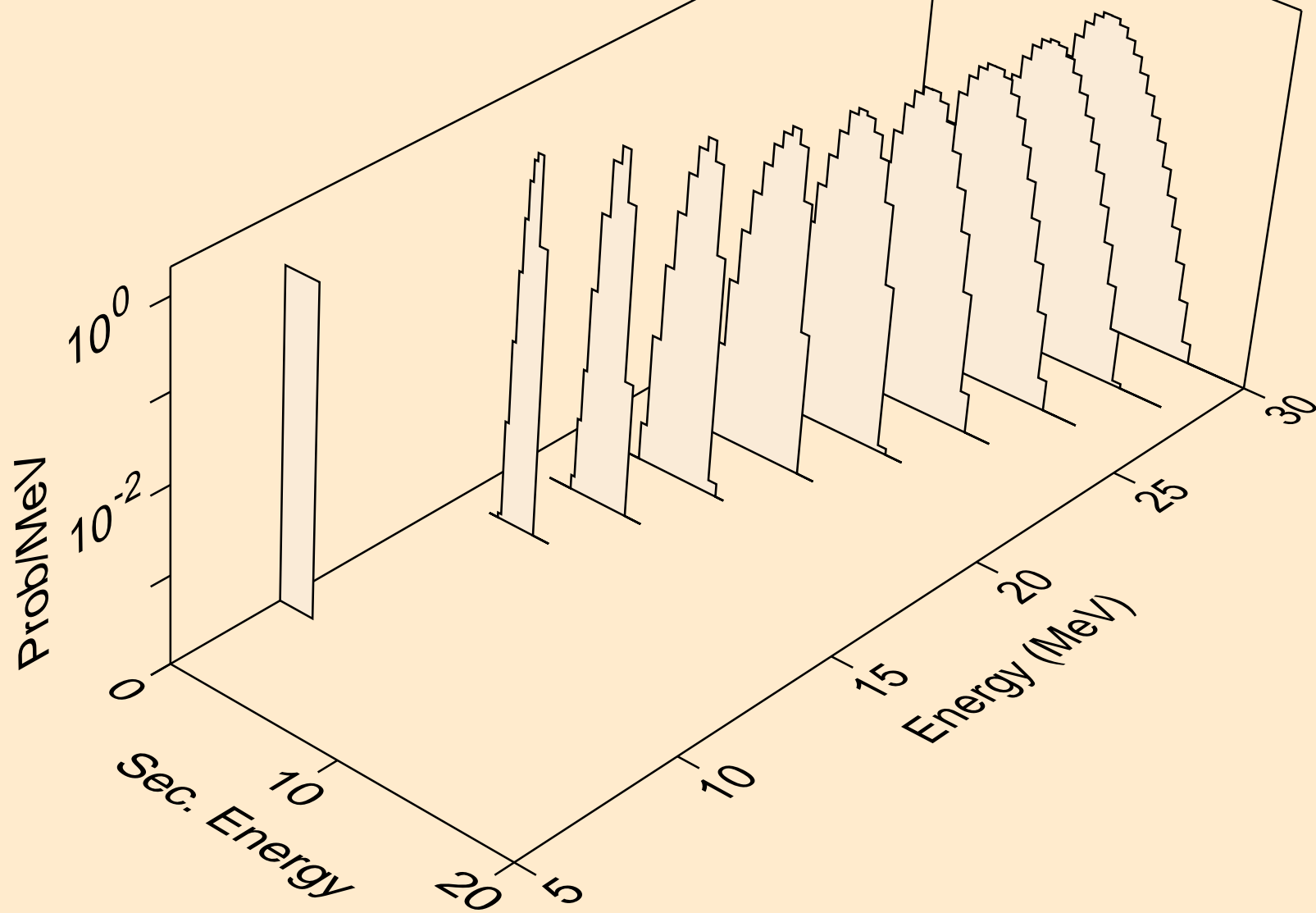

KR073 HELION ACER TENDL-2024 LIBRARY; T=0.K  
alphas from (s,a)

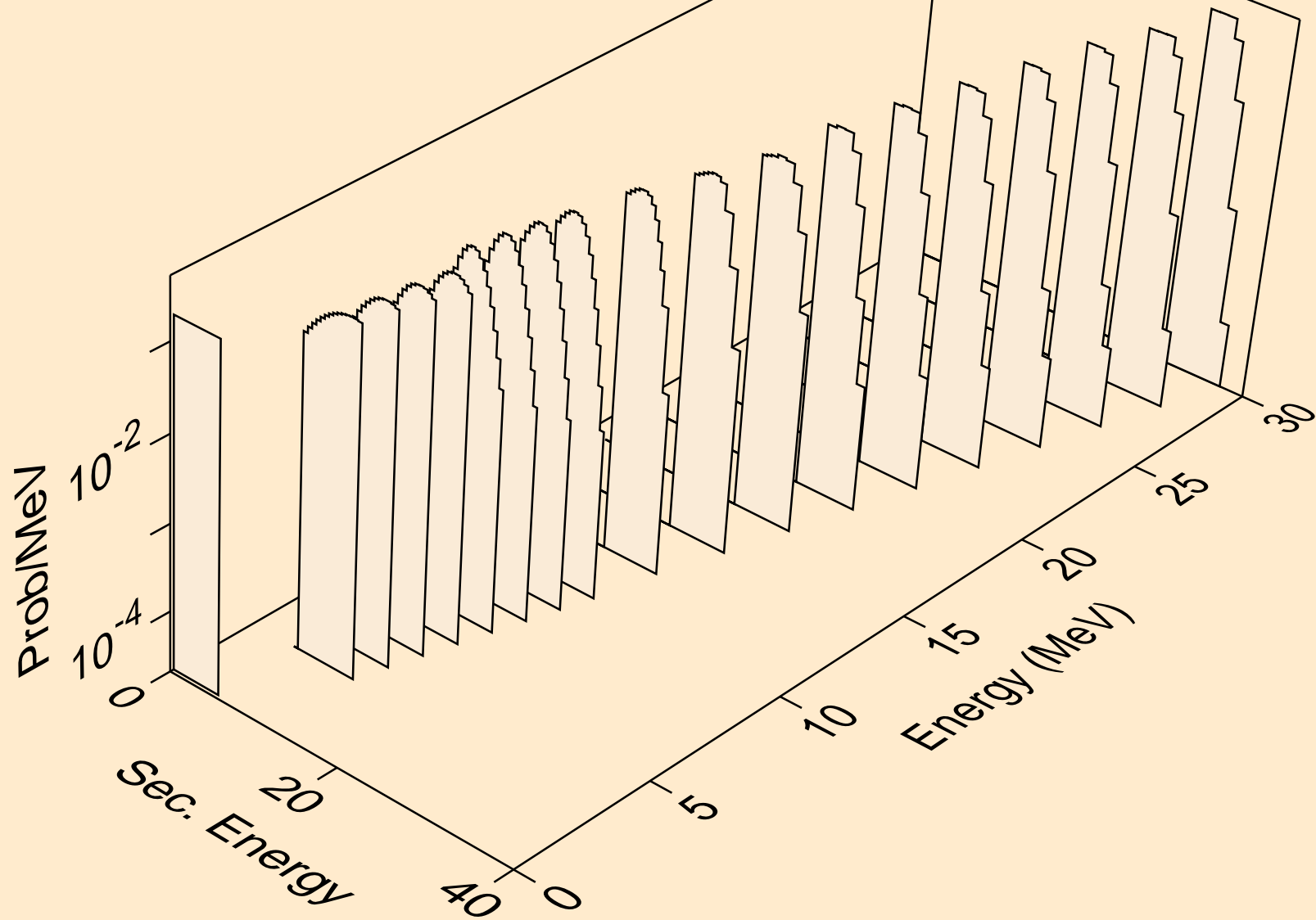

KR073 HELION ACER TENDL-2024 LIBRARY; T=0.K  
alphas from (s,2a)

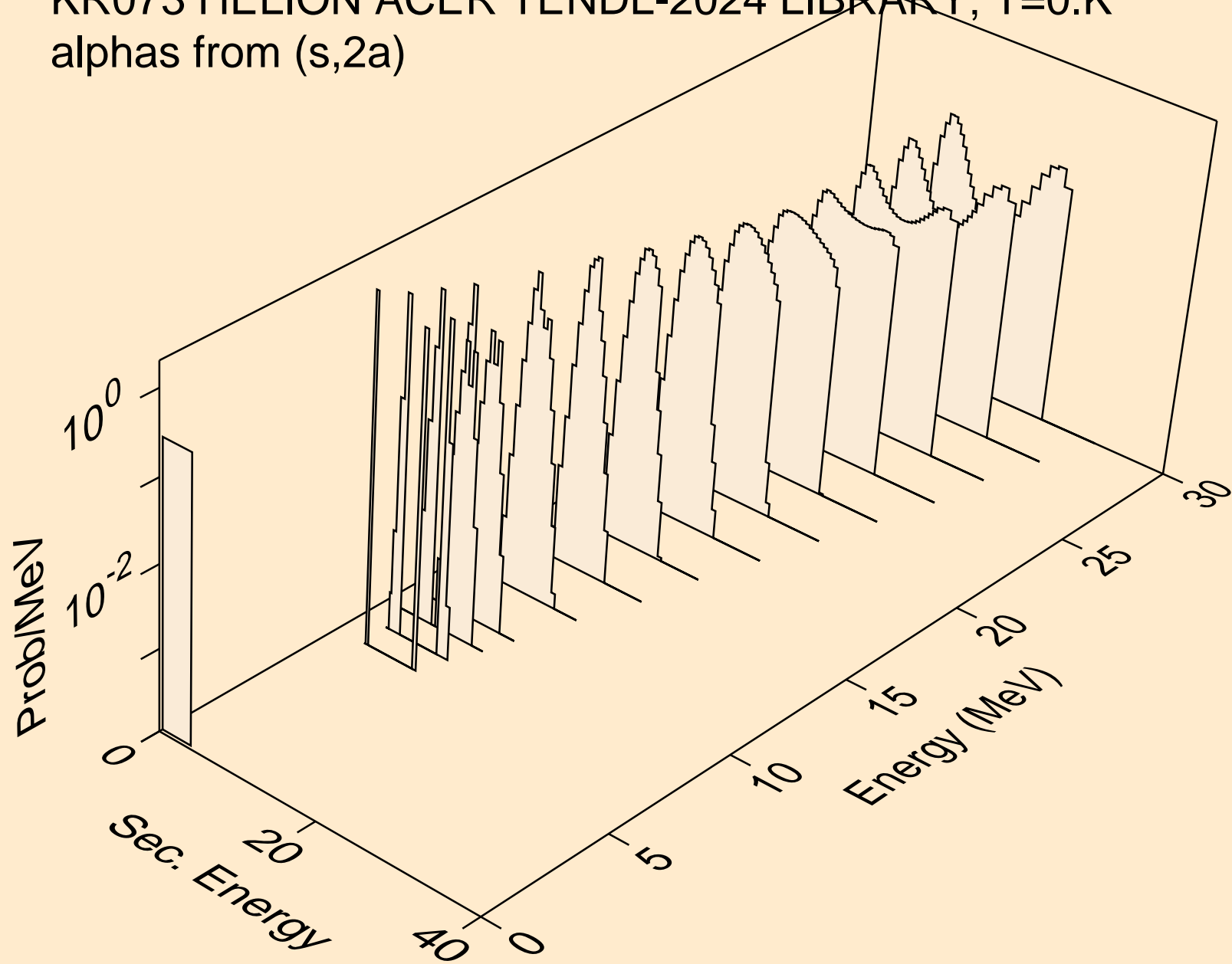

KR073 HELION ACER TENDL-2024 LIBRARY; T=0.K  
alphas from (s,pa)

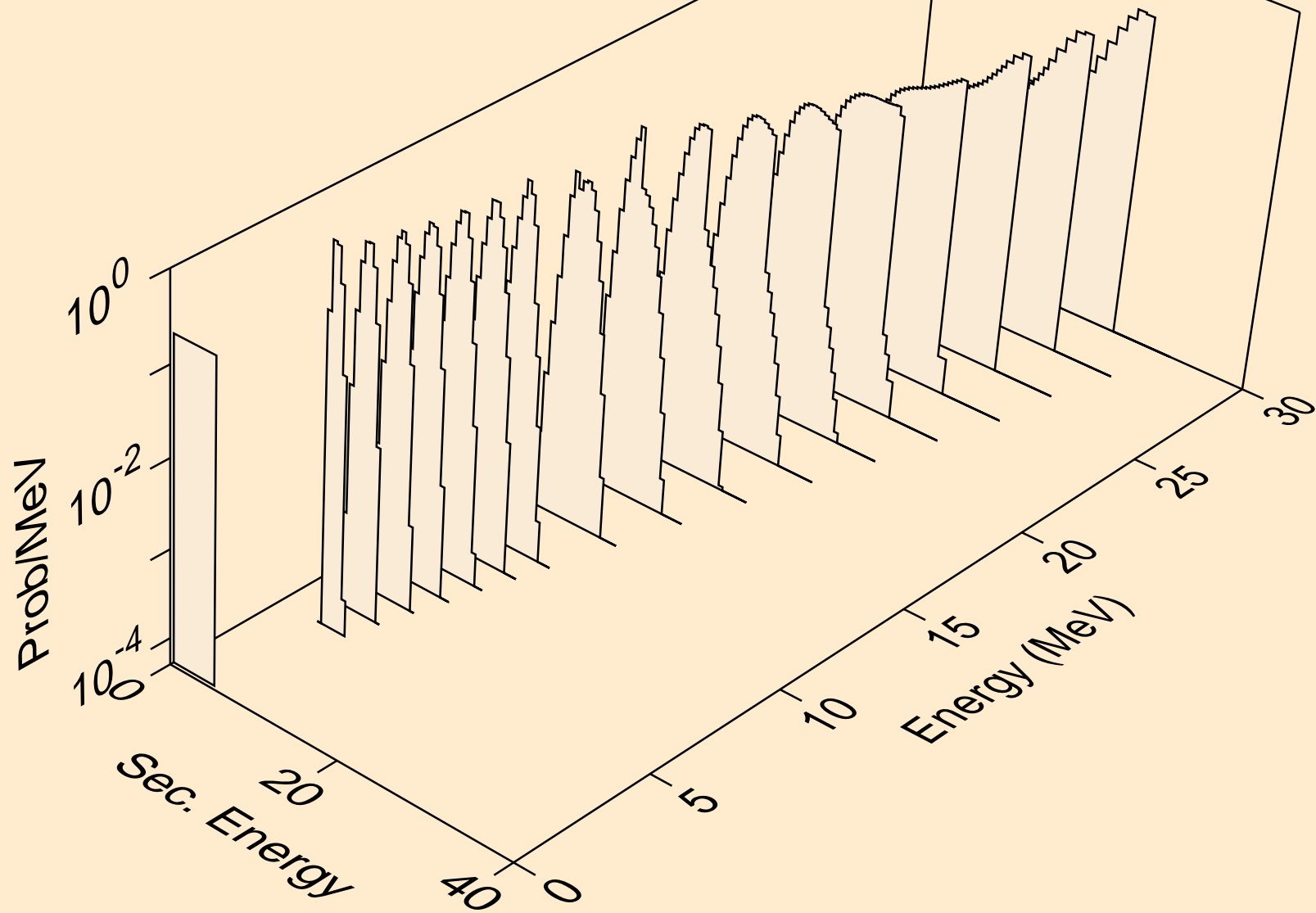

KR073 HELION ACER TENDL-2024 LIBRARY; T=0.K  
alphas from (s,da)

