

# AG111 NEUTRON ACER TENDL-2024 LIBRARY; T=293.6K

## Principal cross sections

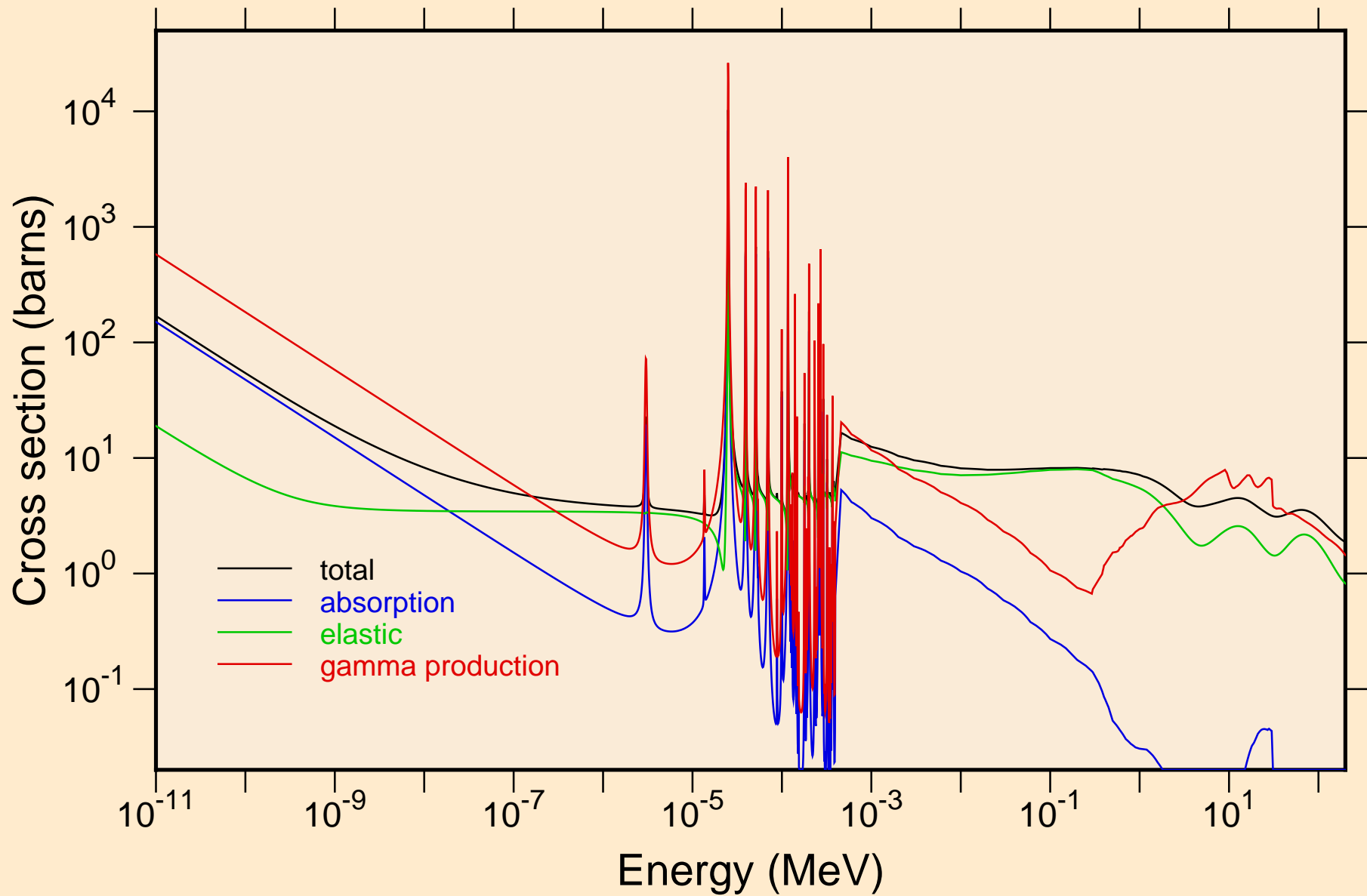

AG111 NEUTRON ACER TENDL-2024 LIBRARY; T=293.6K  
resonance total cross section

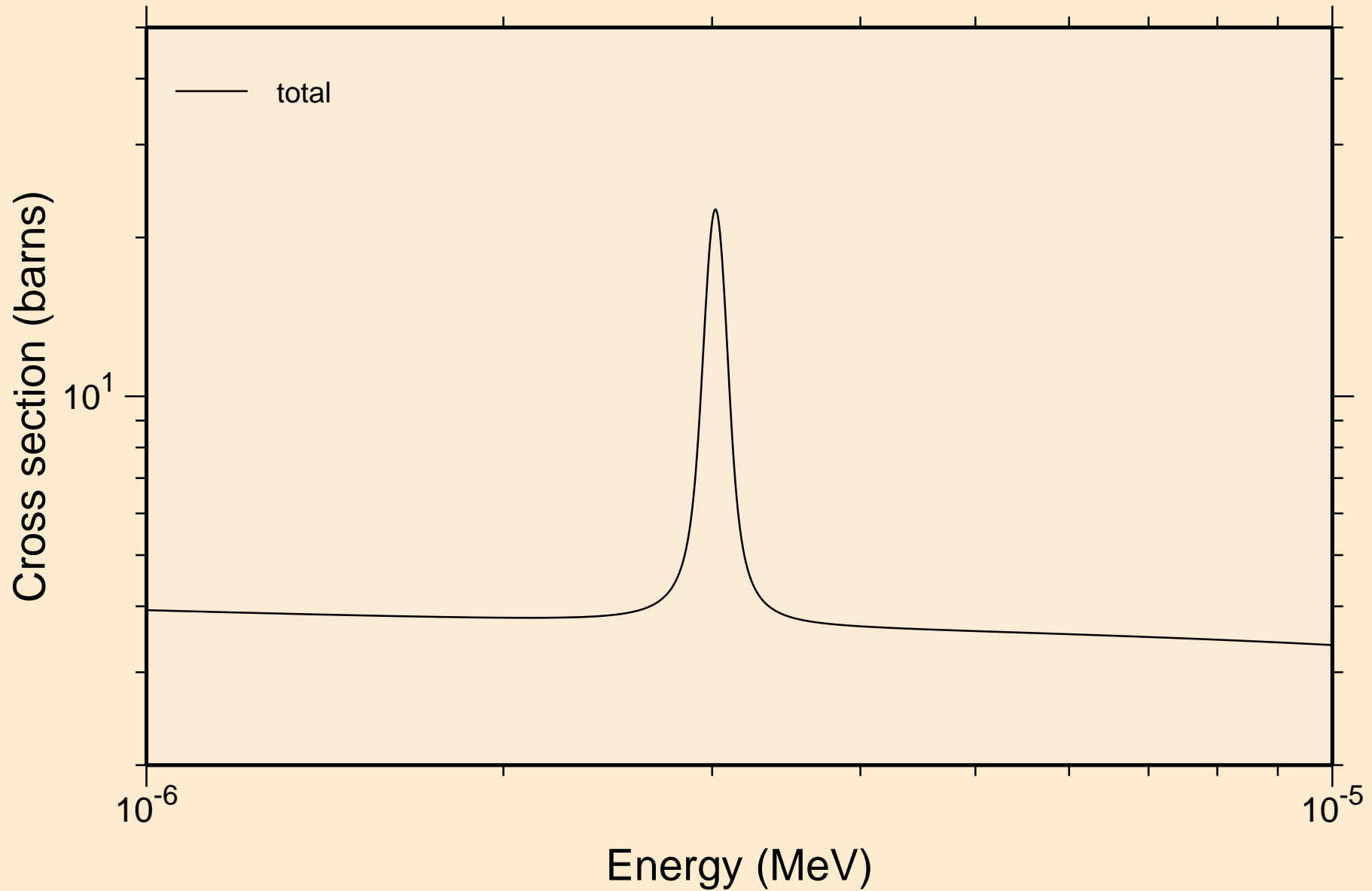

AG111 NEUTRON ACER TENDL-2024 LIBRARY; T=293.6K  
resonance total cross section

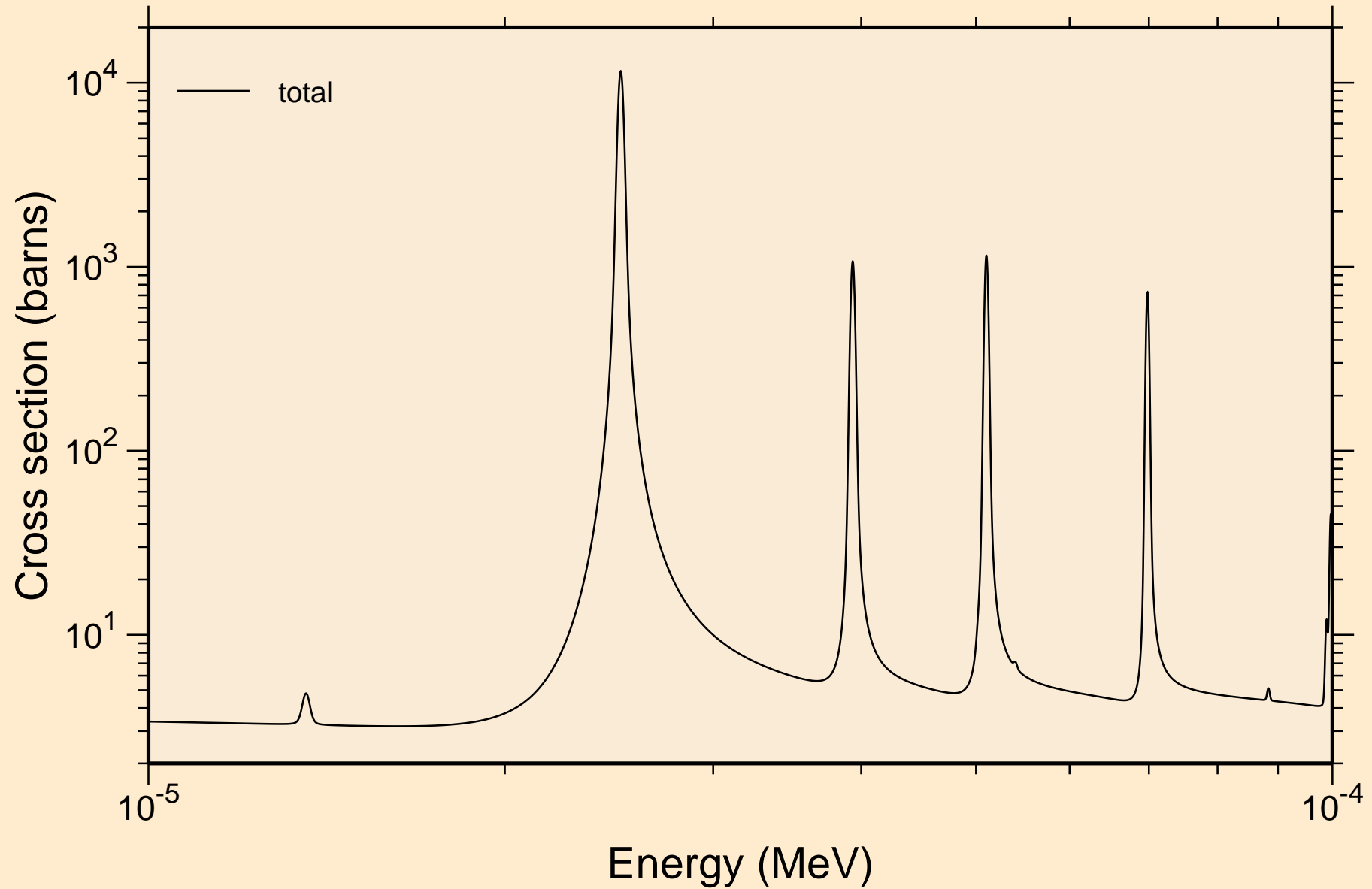

AG111 NEUTRON ACER TENDL-2024 LIBRARY; T=293.6K  
resonance total cross section

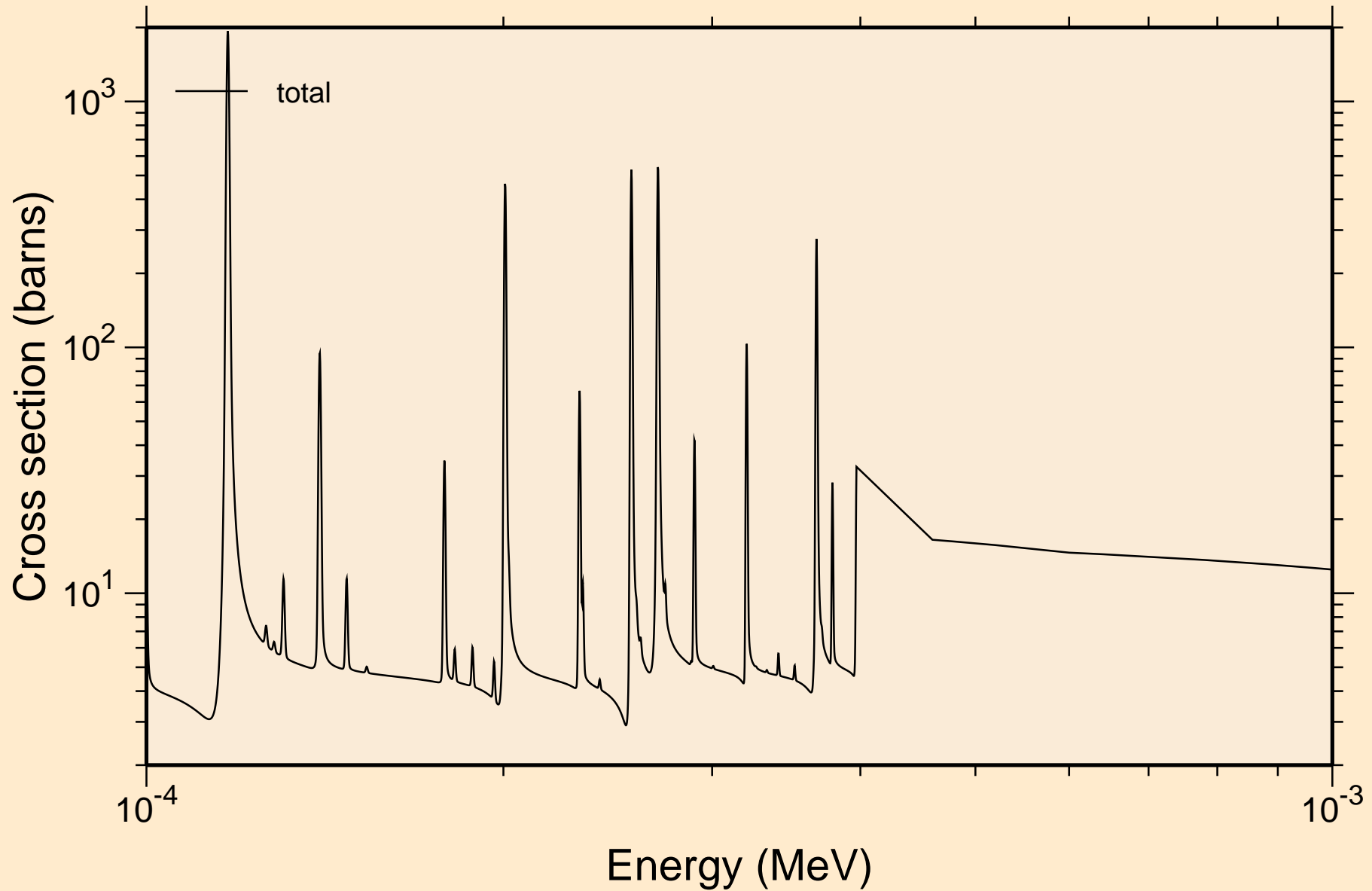

AG111 NEUTRON ACER TENDL-2024 LIBRARY; T=293.6K  
resonance total cross section

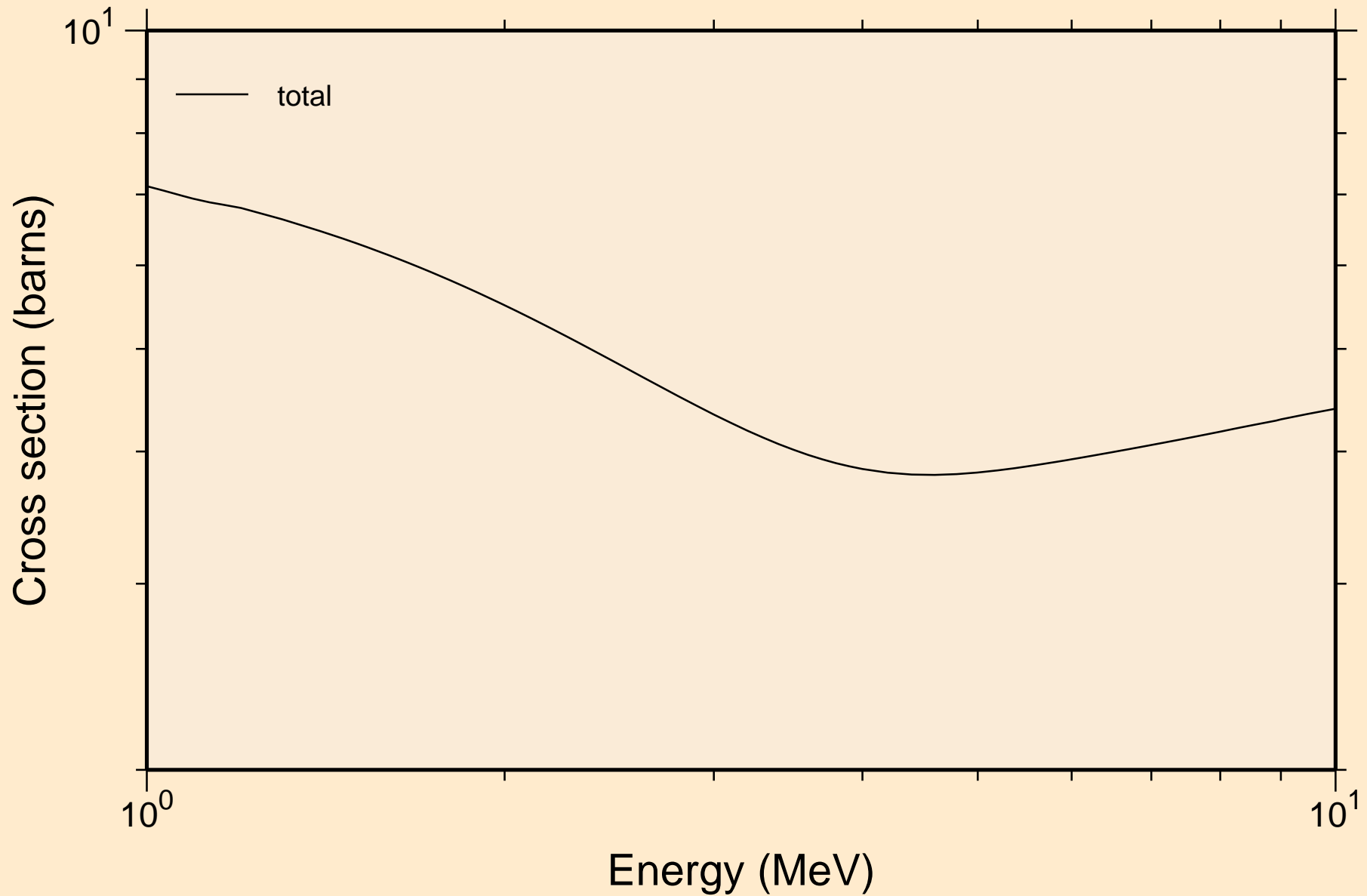

AG111 NEUTRON ACER TENDL-2024 LIBRARY; T=293.6K  
resonance absorption cross sections

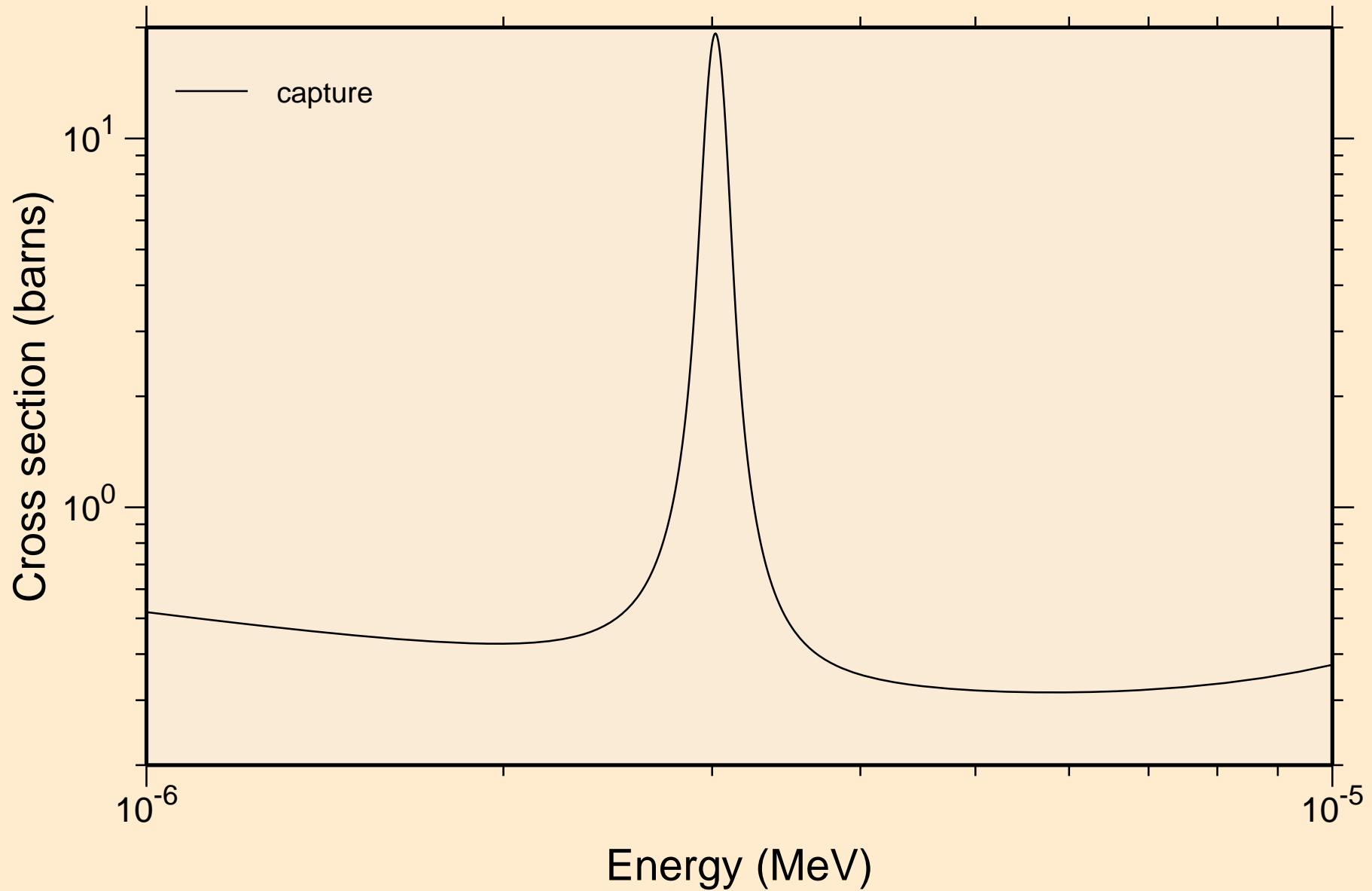

AG111 NEUTRON ACER TENDL-2024 LIBRARY; T=293.6K  
resonance absorption cross sections

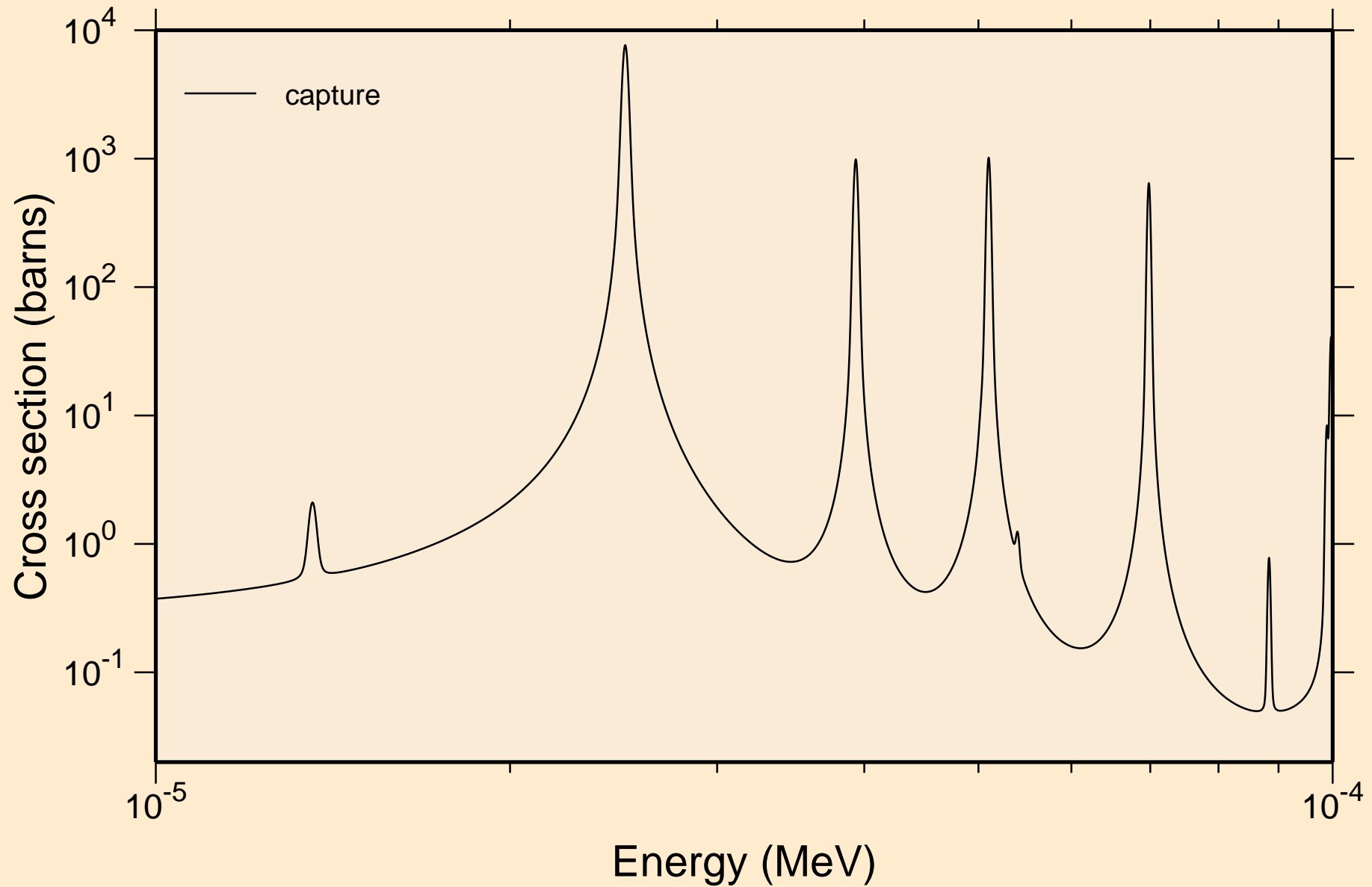

AG111 NEUTRON ACER TENDL-2024 LIBRARY; T=293.6K  
resonance absorption cross sections

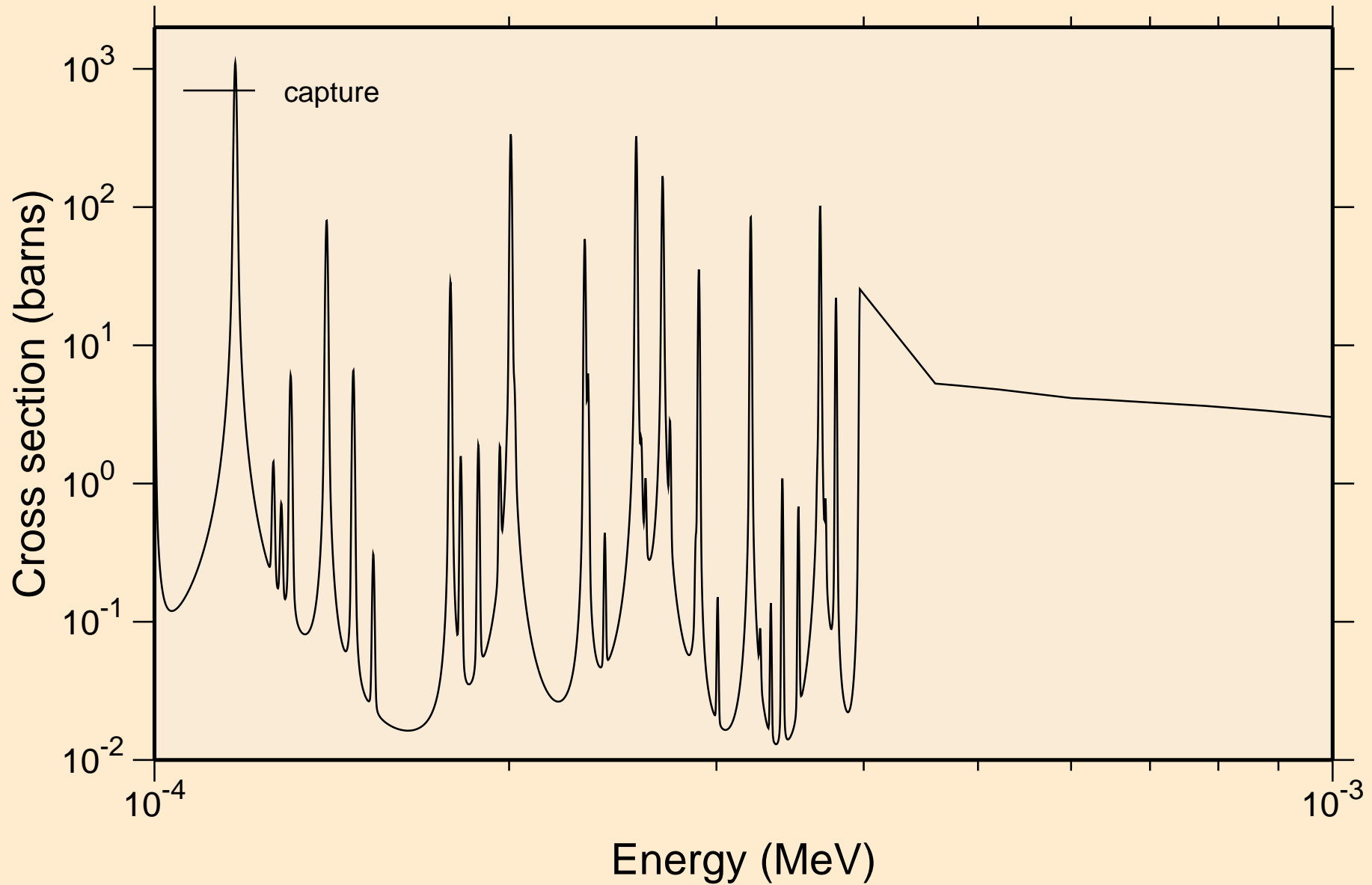

AG111 NEUTRON ACER TENDL-2024 LIBRARY; T=293.6K  
resonance absorption cross sections

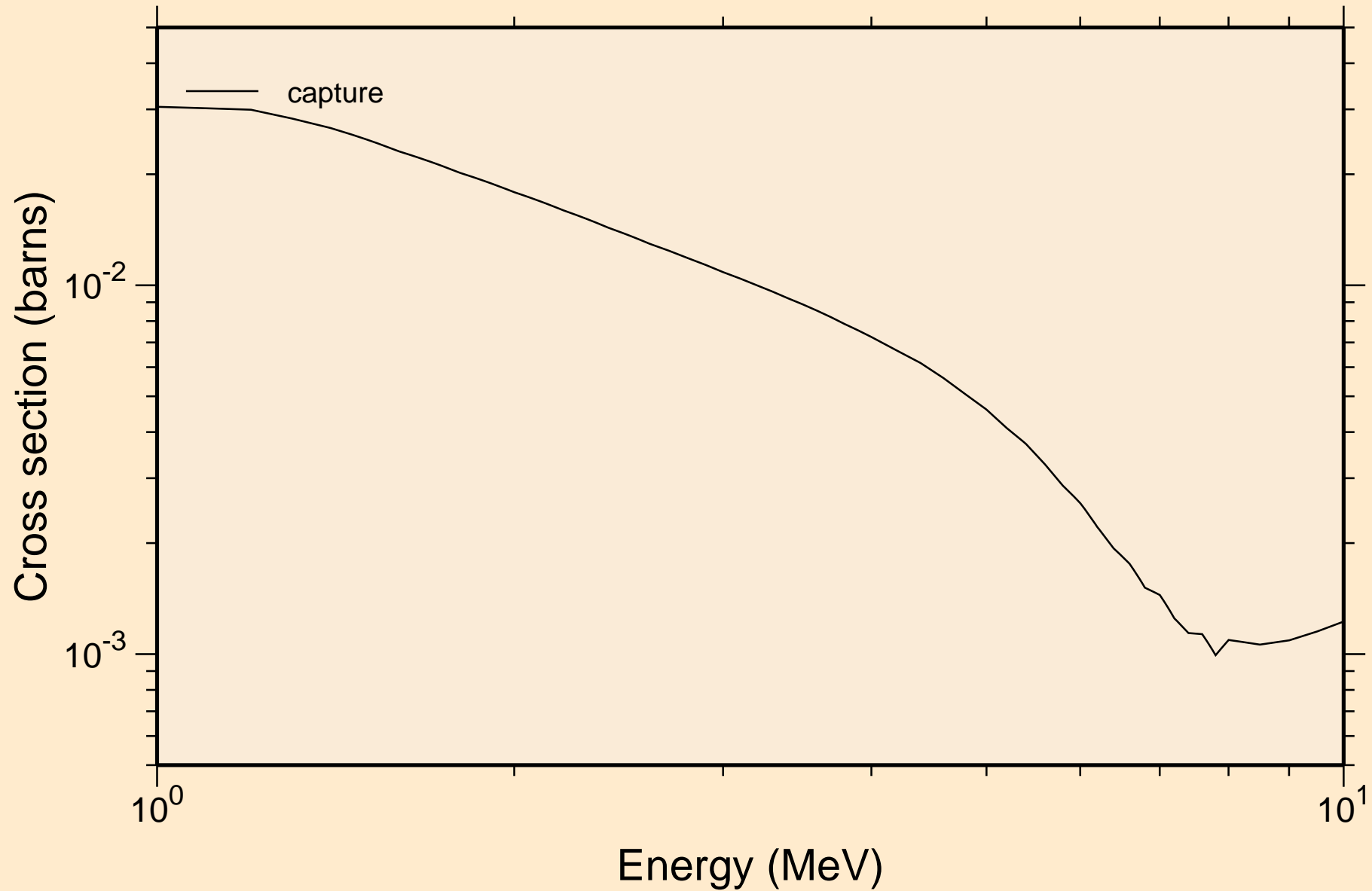

AG111 NEUTRON ACER TENDL-2024 LIBRARY; T=293.6K  
Heating

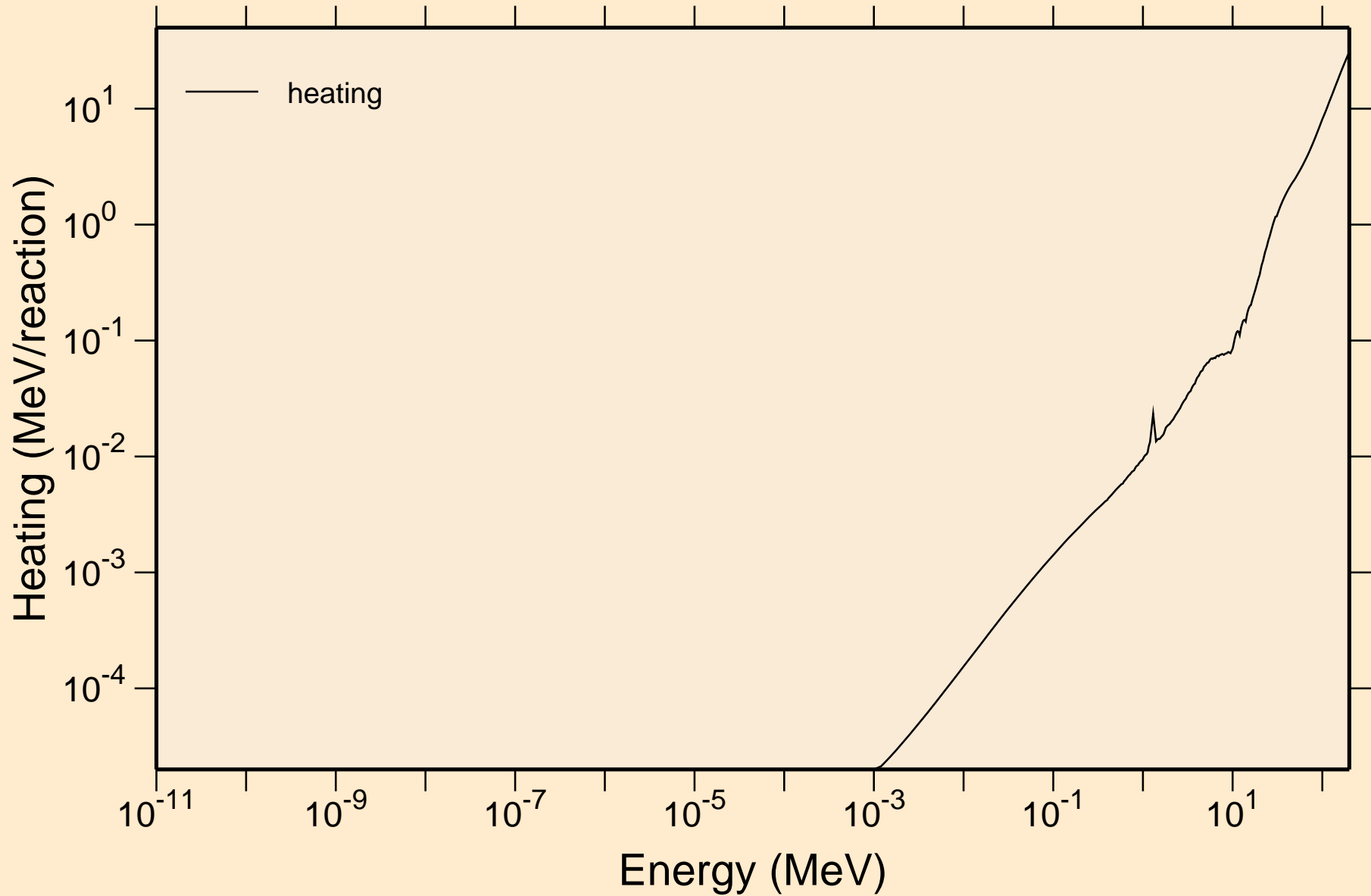

# AG111 NEUTRON ACER TENDL-2024 LIBRARY; T=293.6K

## Damage

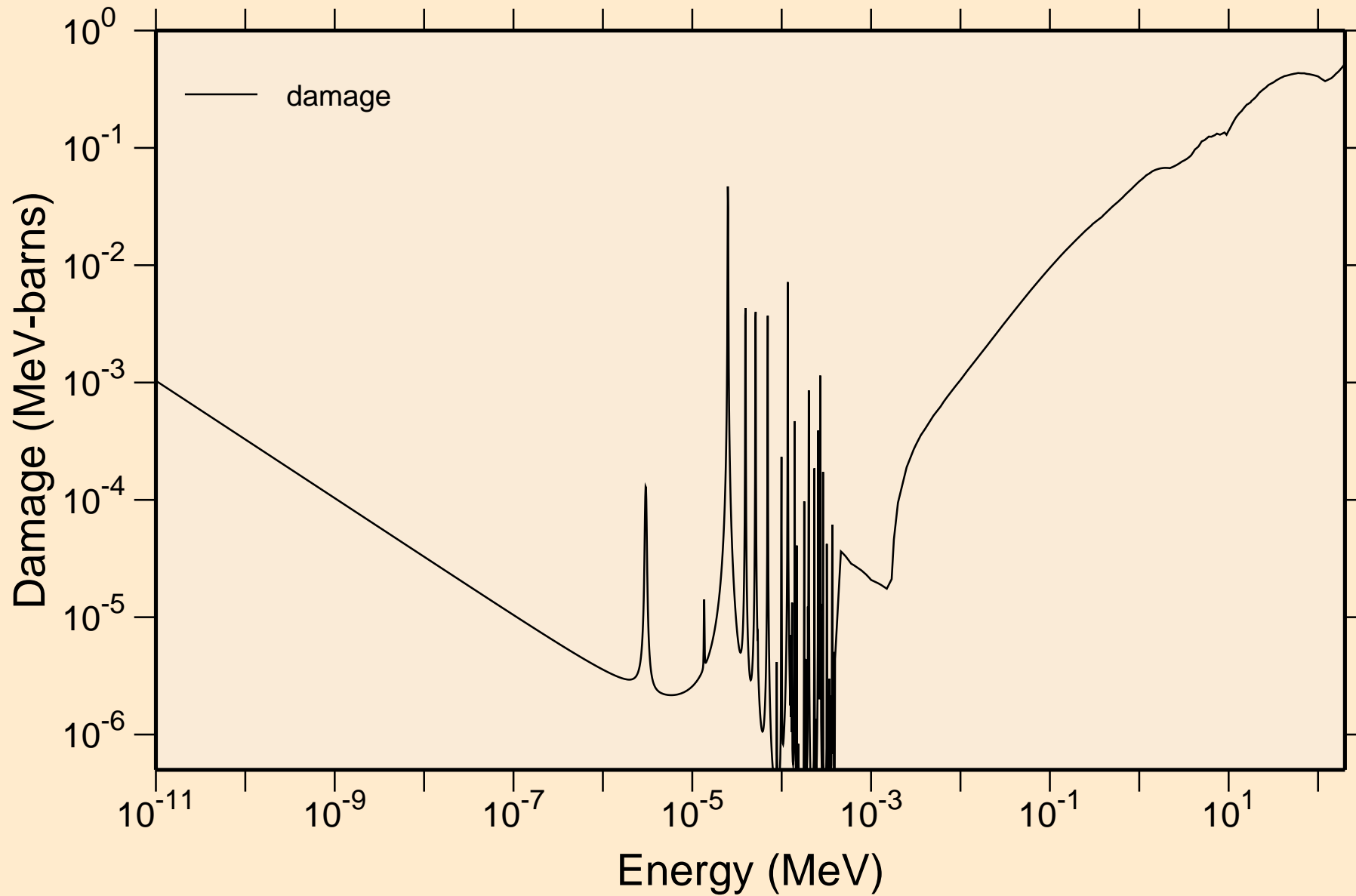

AG111 NEUTRON ACER TENDL-2024 LIBRARY; T=293.6K  
Non-threshold reactions

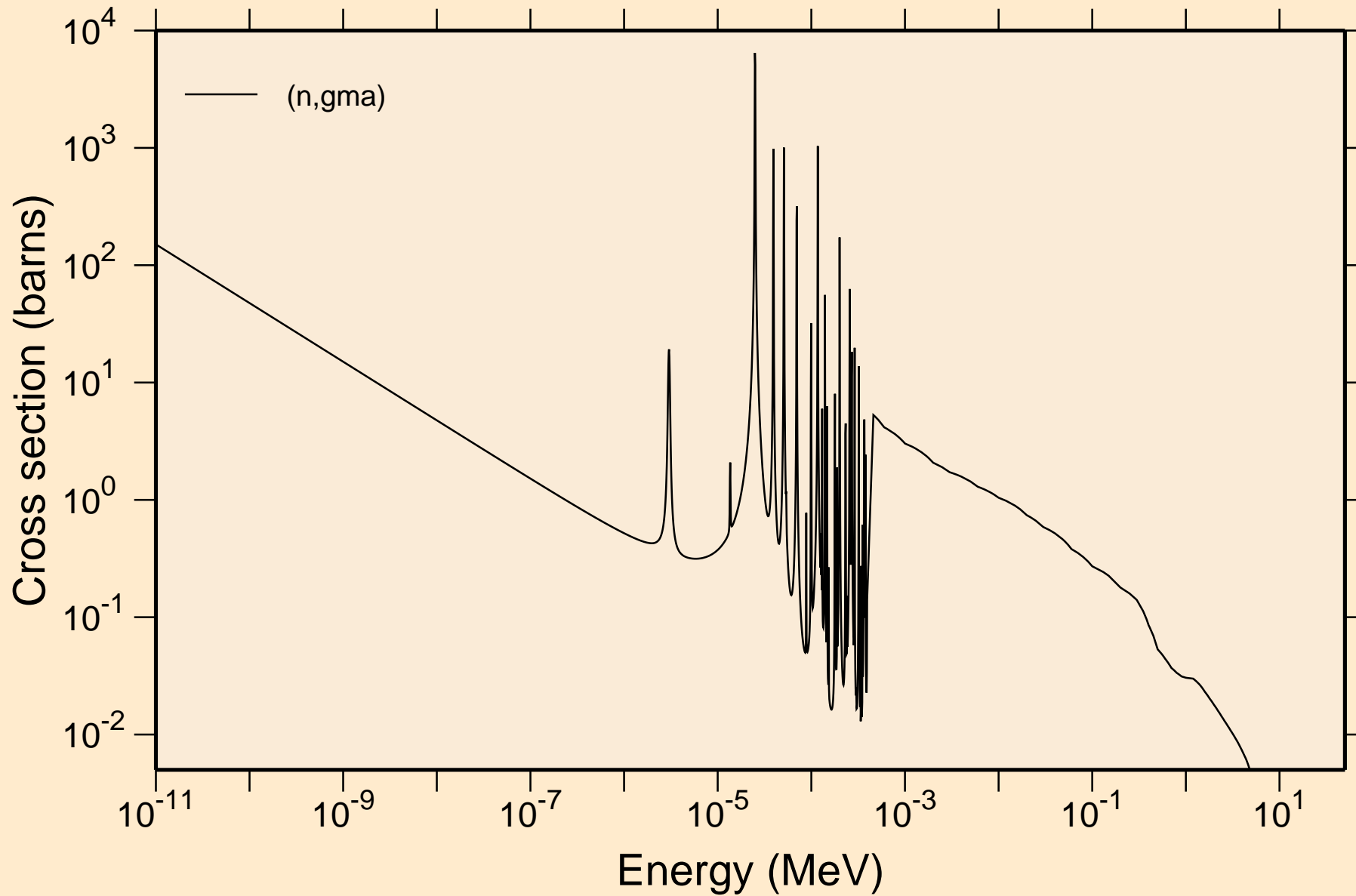

# AG111 NEUTRON ACER TENDL-2024 LIBRARY; T=293.6K

## Principal cross sections

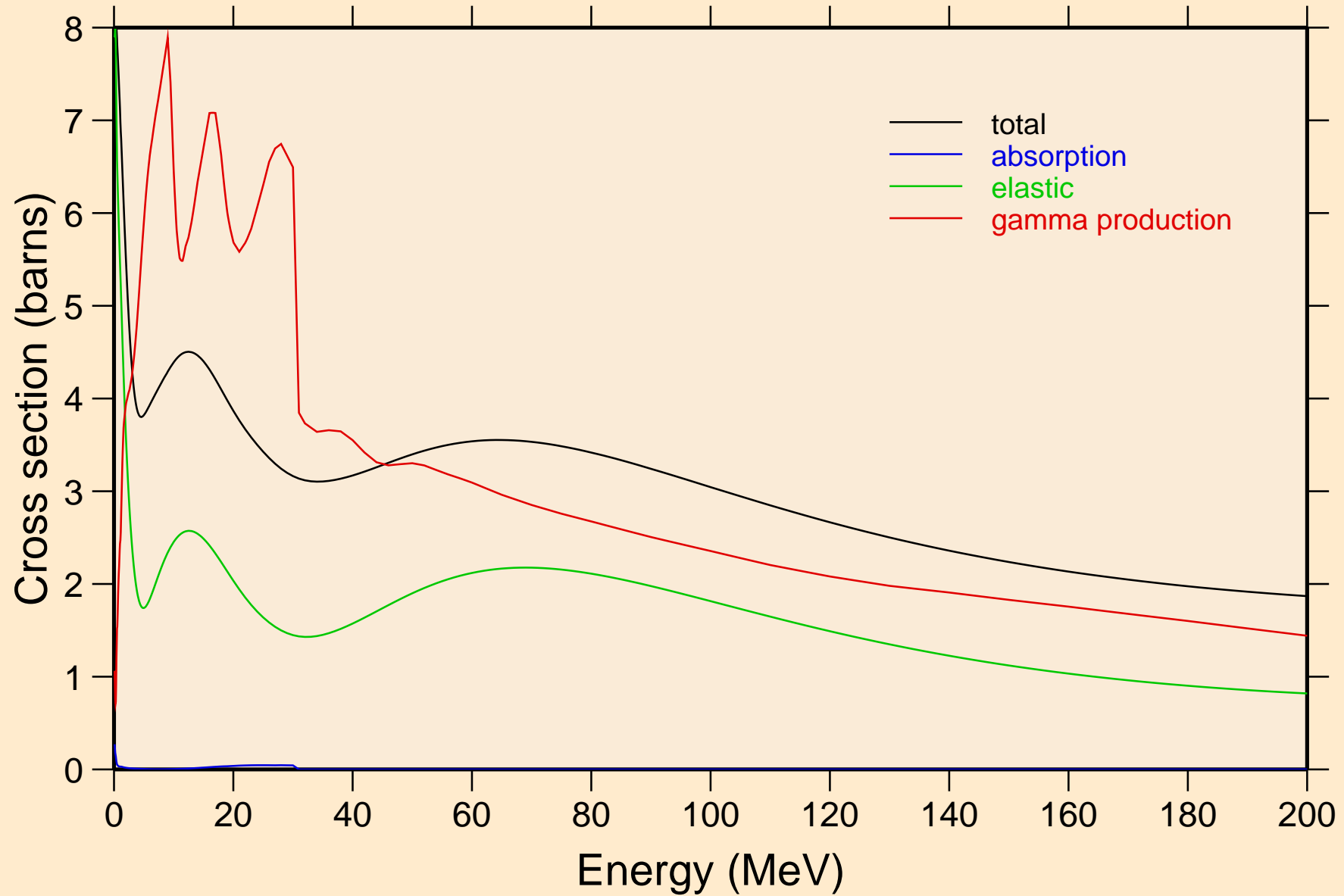

AG111 NEUTRON ACER TENDL-2024 LIBRARY; T=293.6K  
Heating

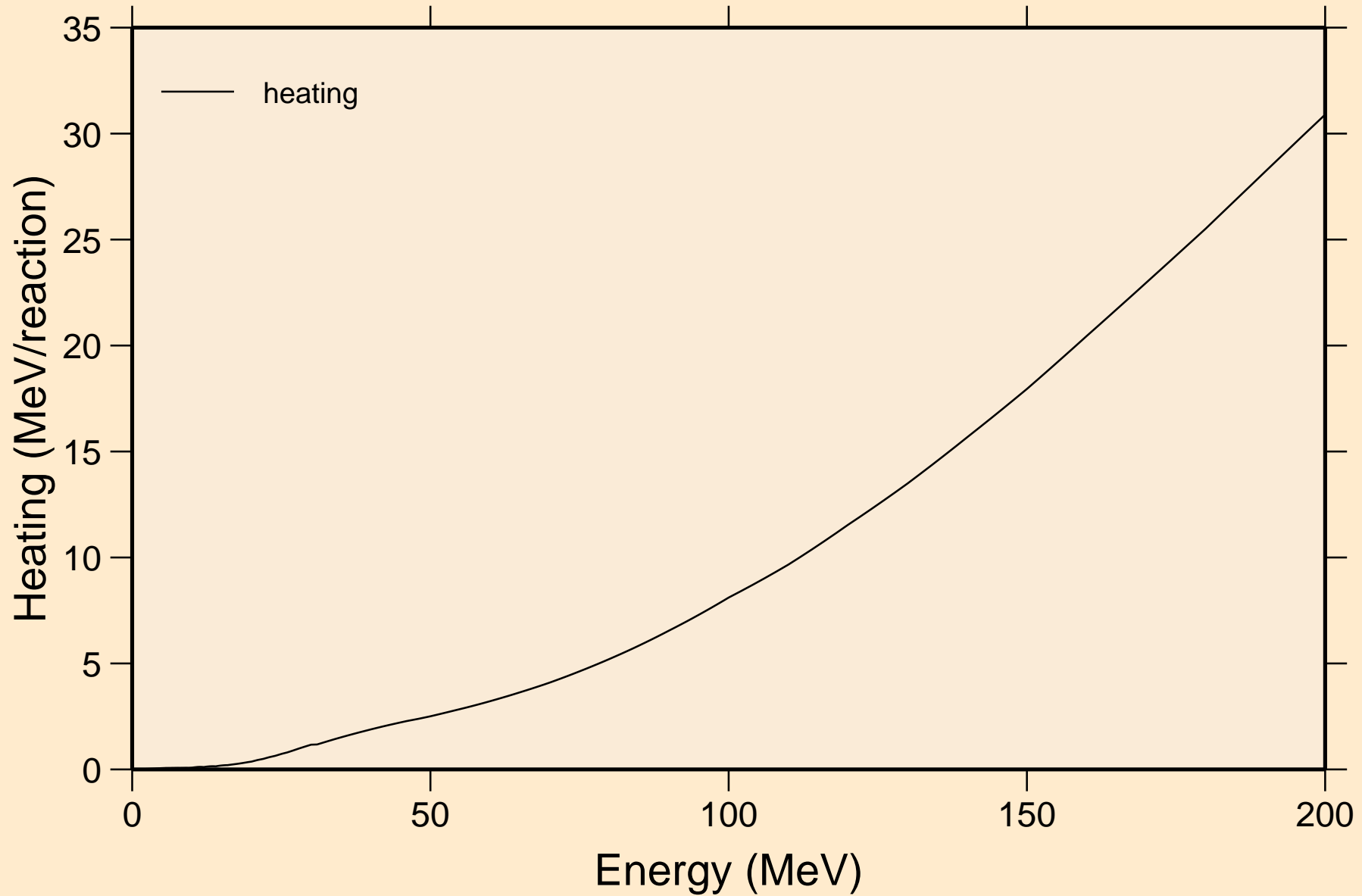

AG111 NEUTRON ACER TENDL-2024 LIBRARY; T=293.6K  
Damage

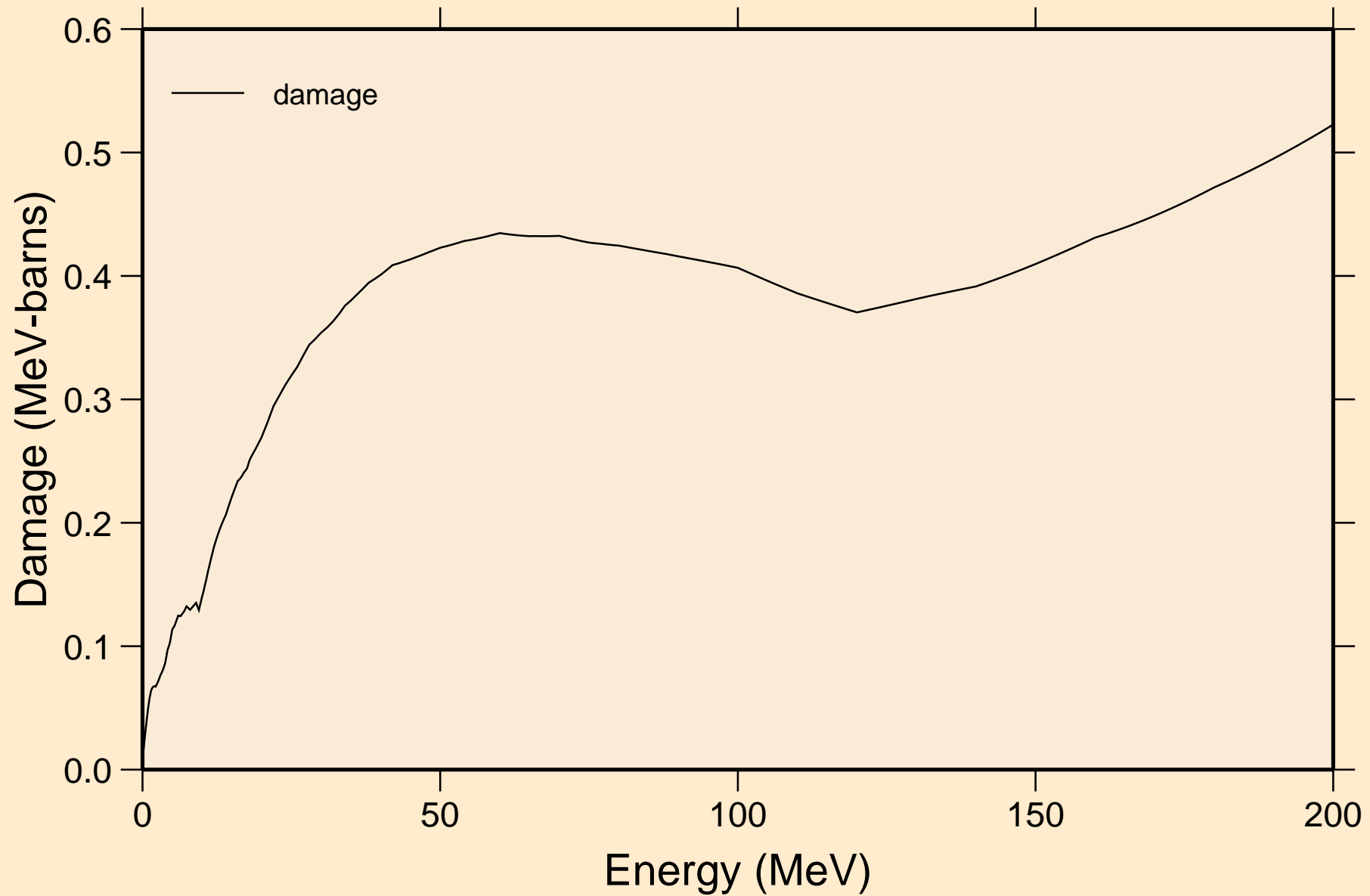

AG111 NEUTRON ACER TENDL-2024 LIBRARY; T=293.6K  
Non-threshold reactions

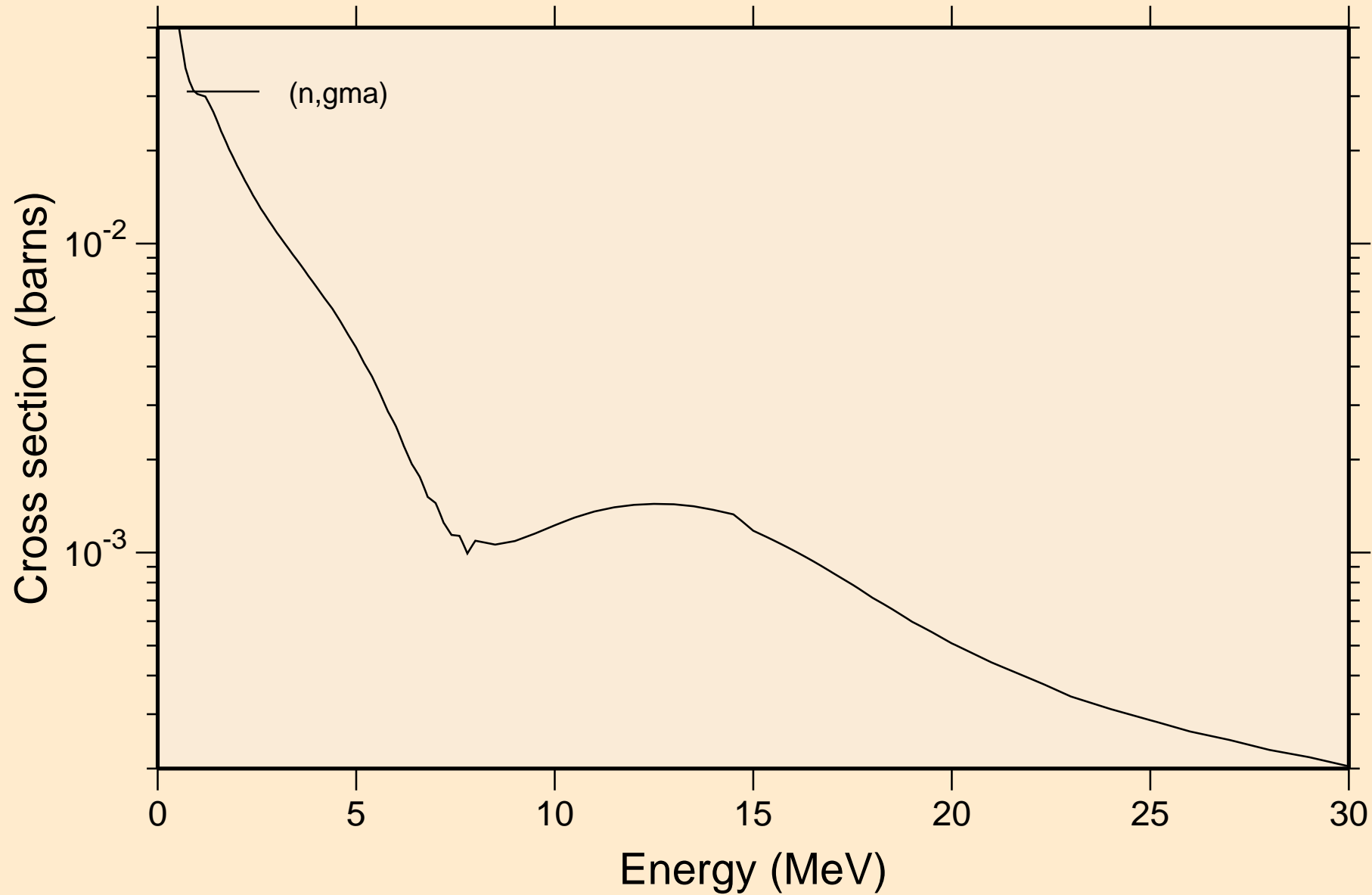

AG111 NEUTRON ACER TENDL-2024 LIBRARY; T=293.6K  
Inelastic levels

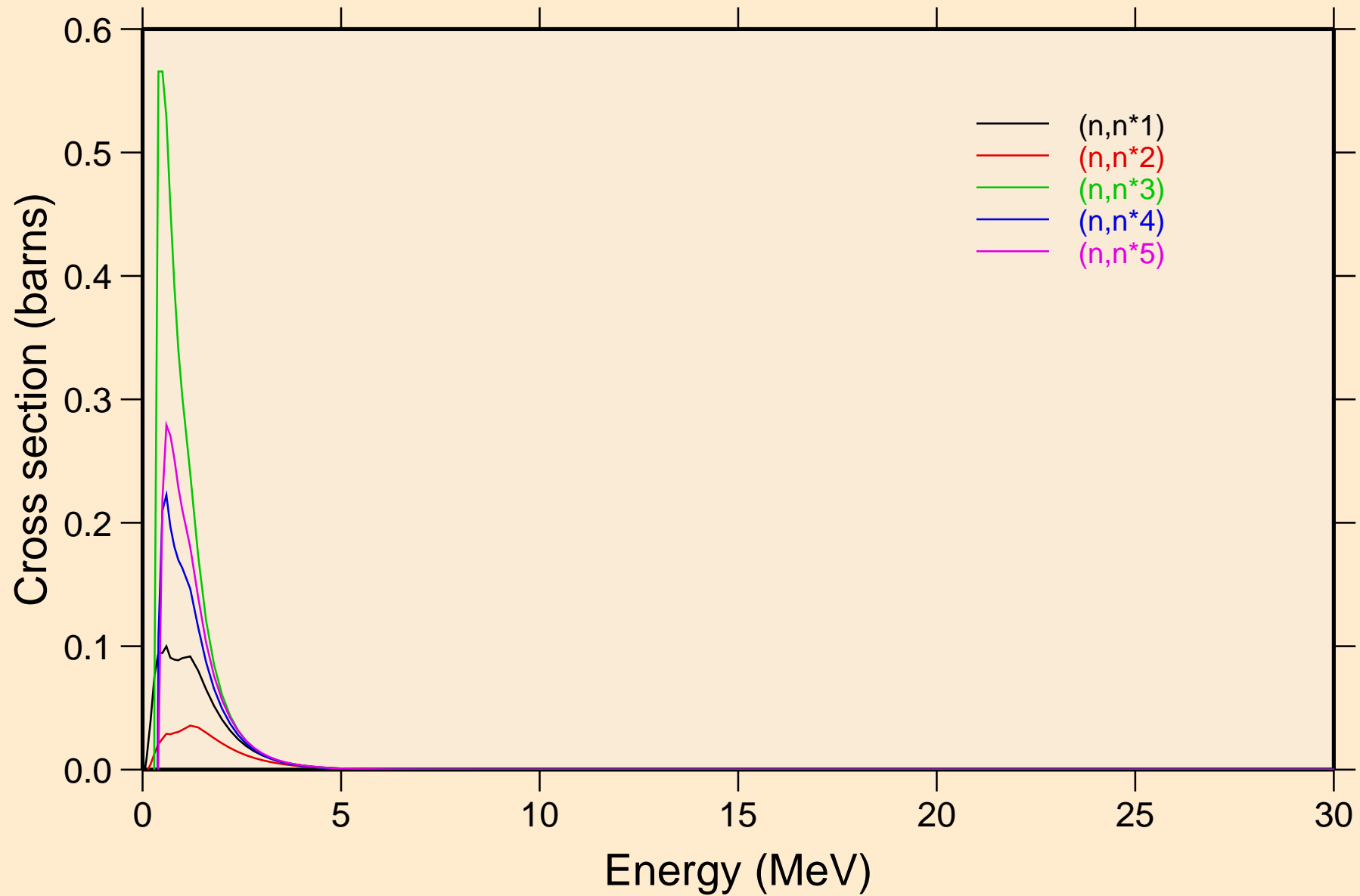

AG111 NEUTRON ACER TENDL-2024 LIBRARY; T=293.6K  
Inelastic levels

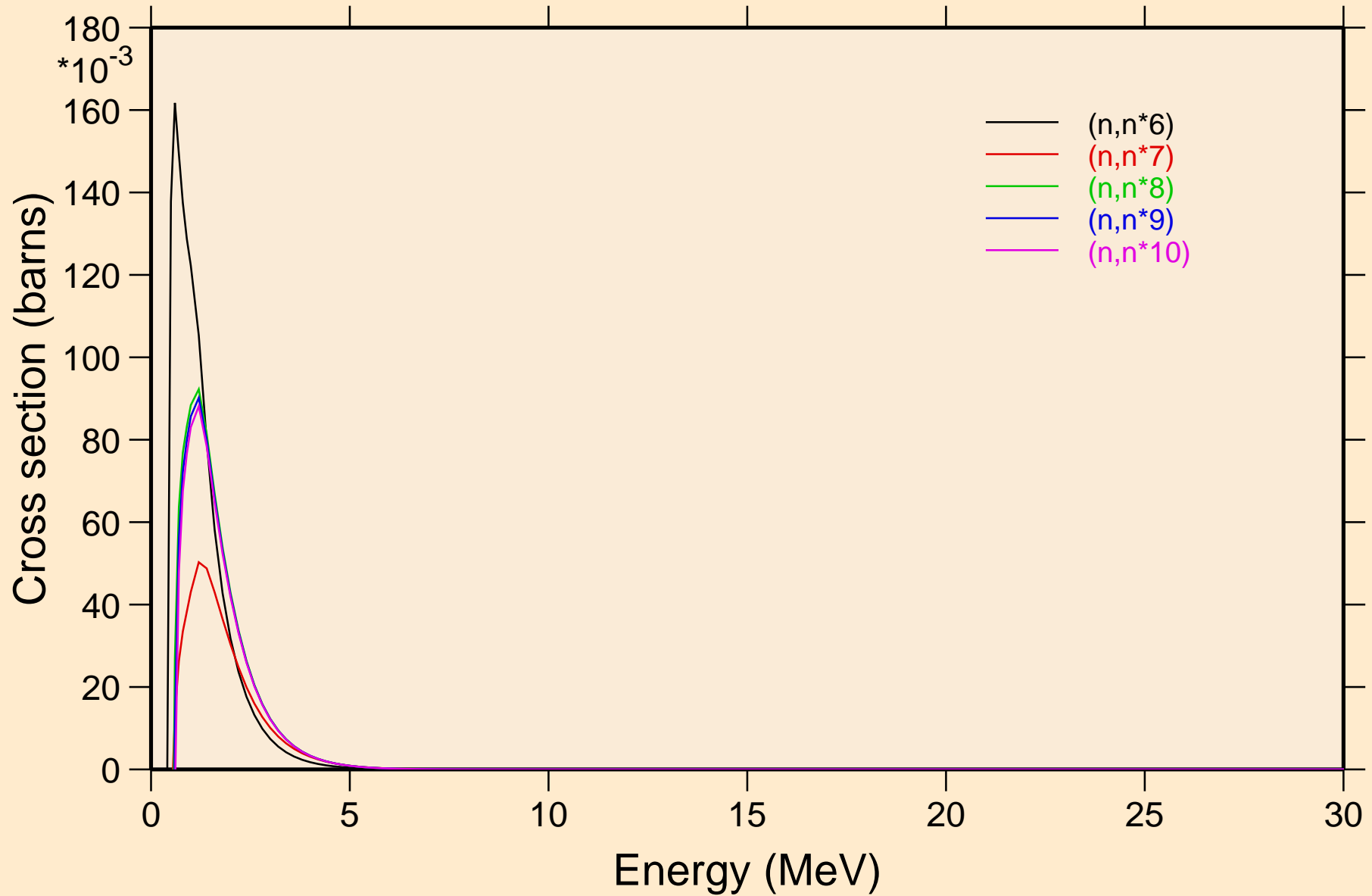

AG111 NEUTRON ACER TENDL-2024 LIBRARY; T=293.6K  
Inelastic levels

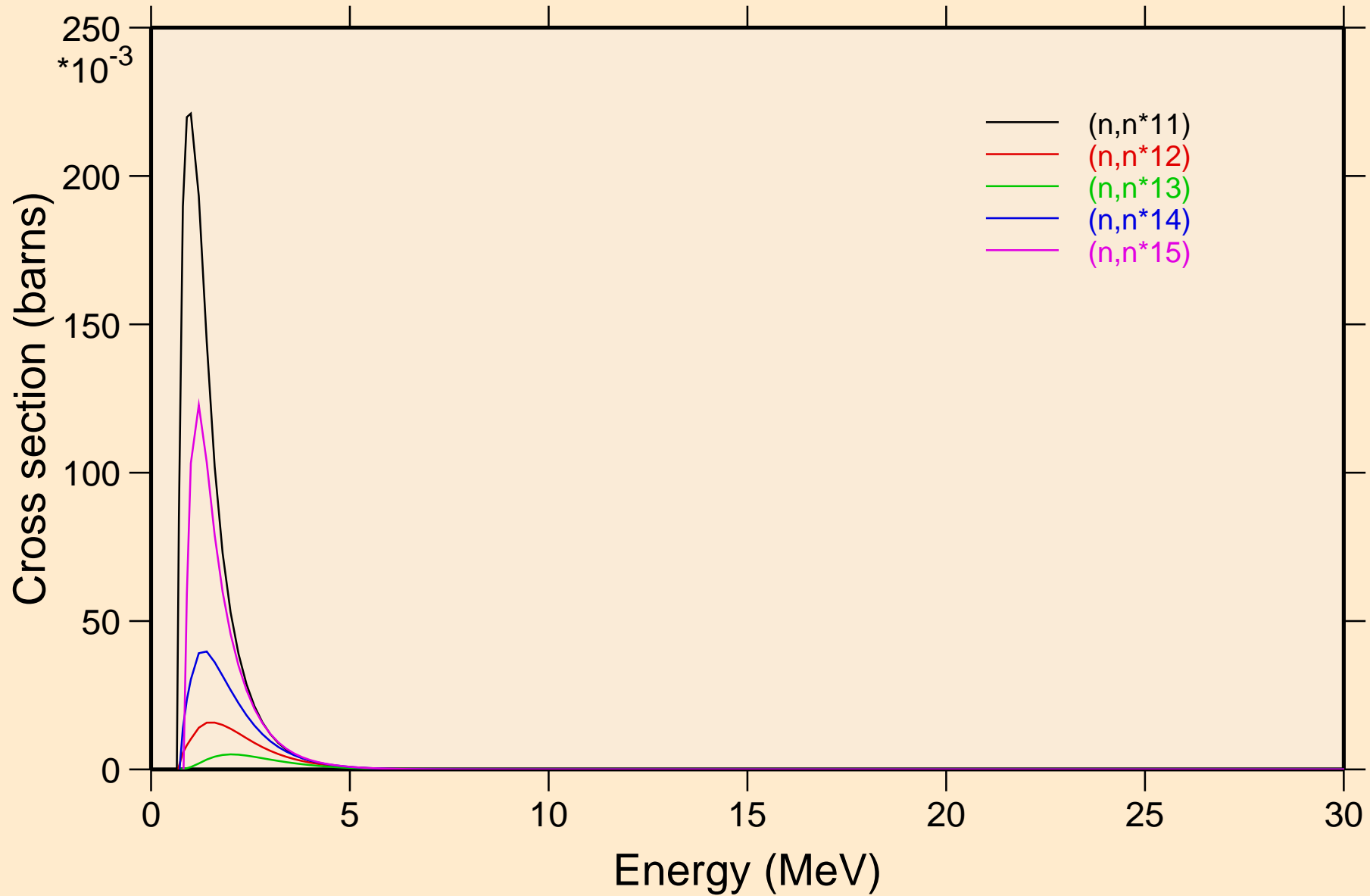

AG111 NEUTRON ACER TENDL-2024 LIBRARY; T=293.6K  
Inelastic levels

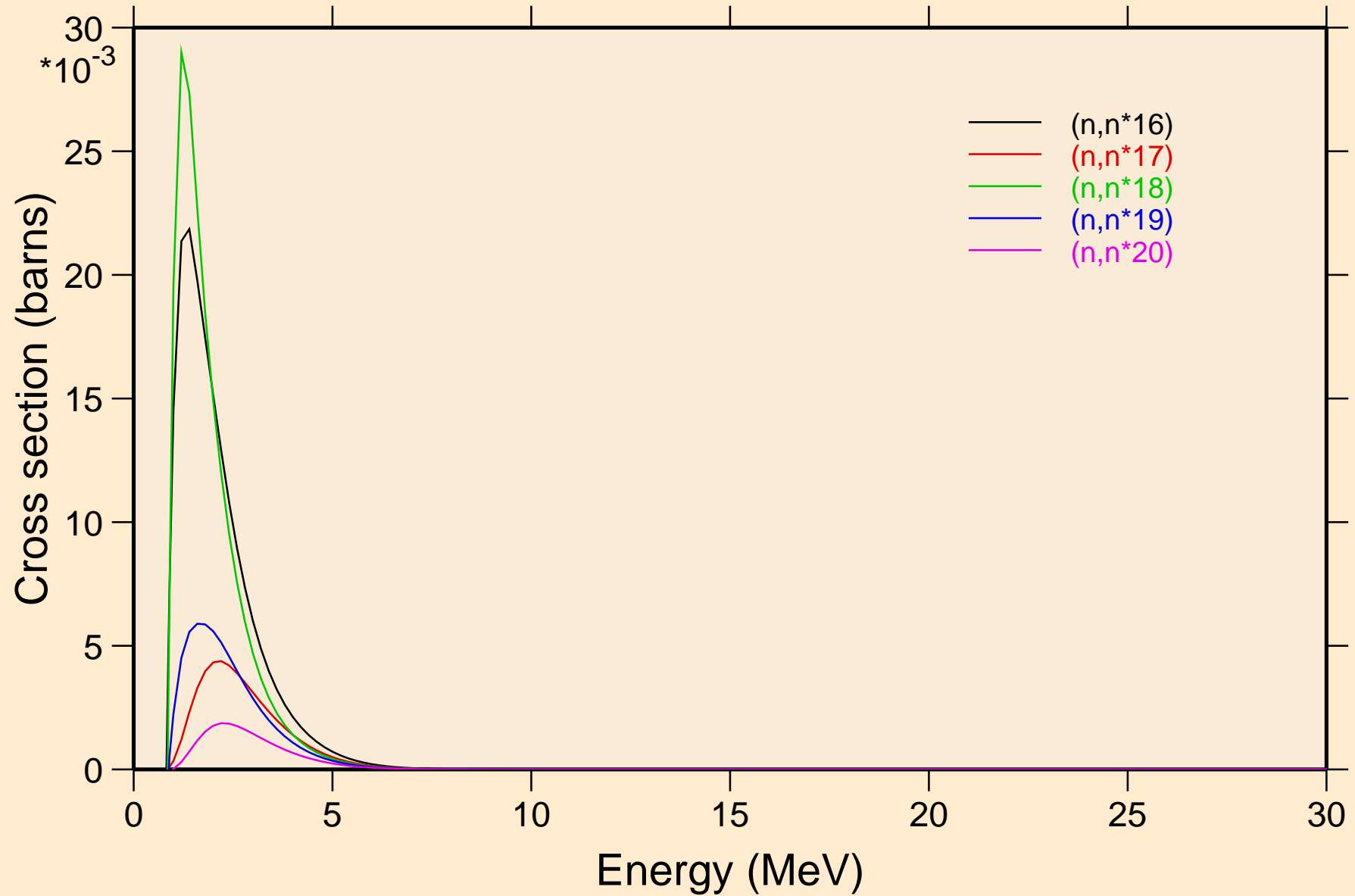

AG111 NEUTRON ACER TENDL-2024 LIBRARY; T=293.6K  
Inelastic levels

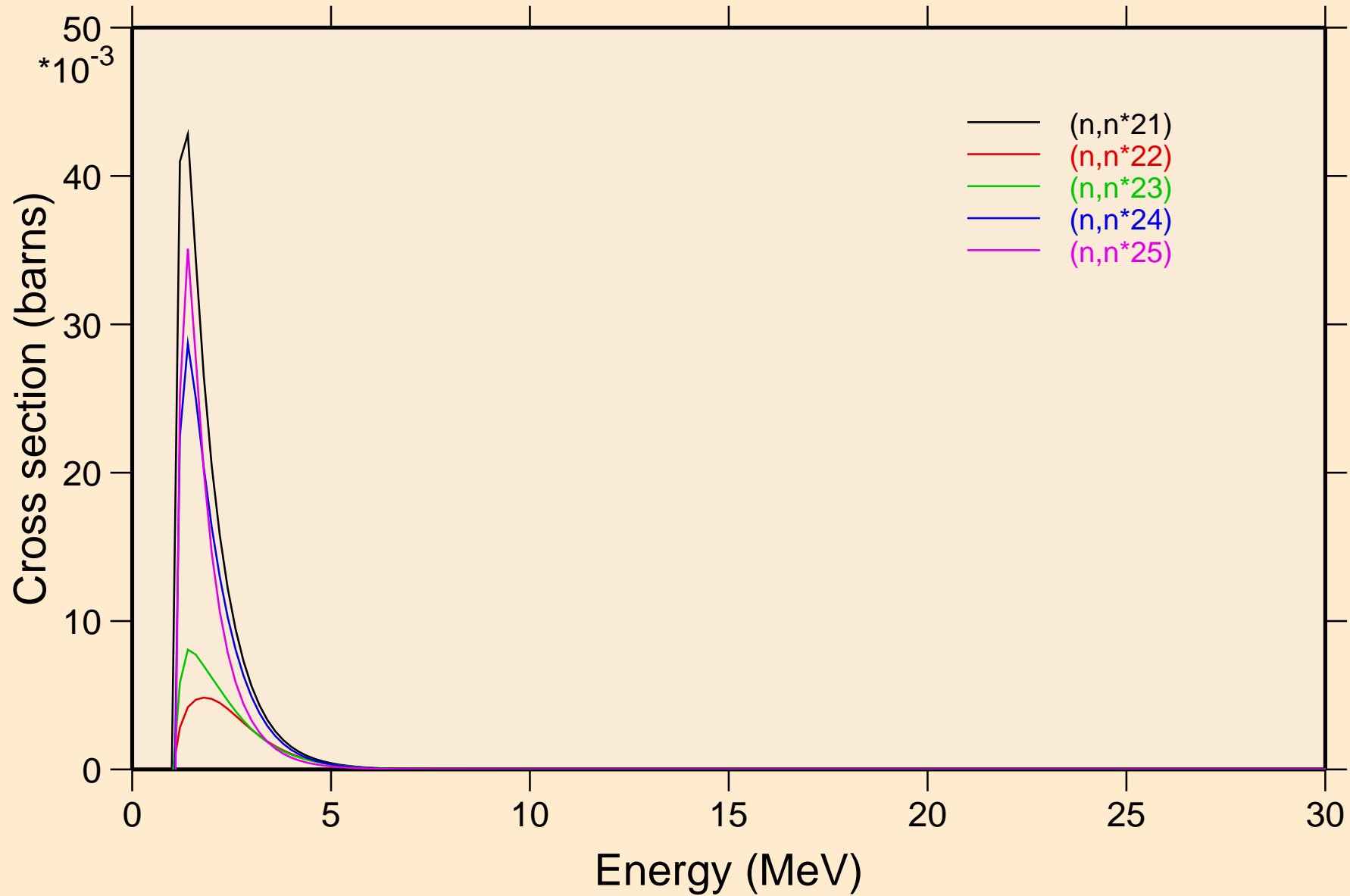

AG111 NEUTRON ACER TENDL-2024 LIBRARY; T=293.6K  
Inelastic levels

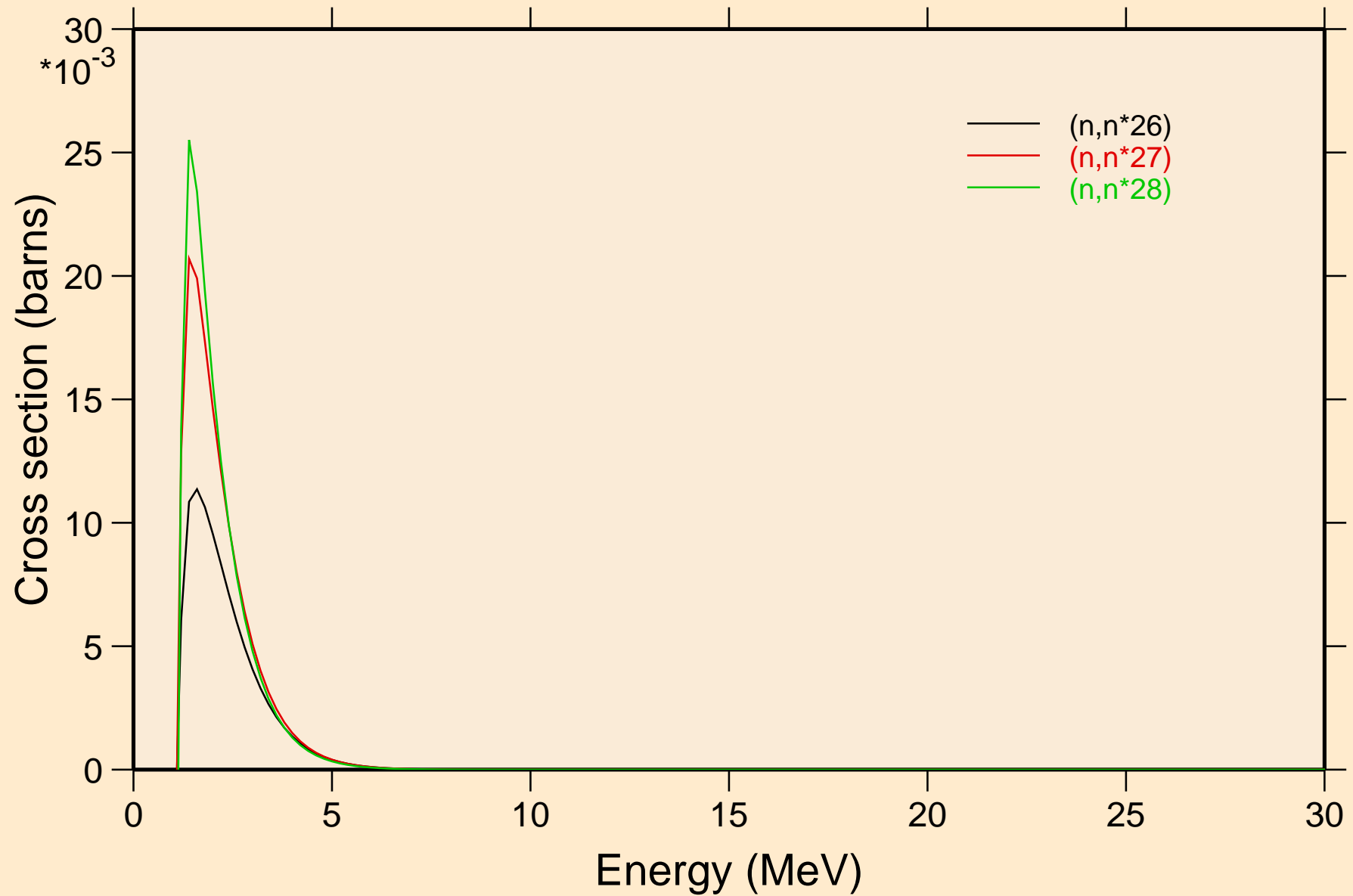

# AG111 NEUTRON ACER TENDL-2024 LIBRARY; T=293.6K

## Threshold reactions

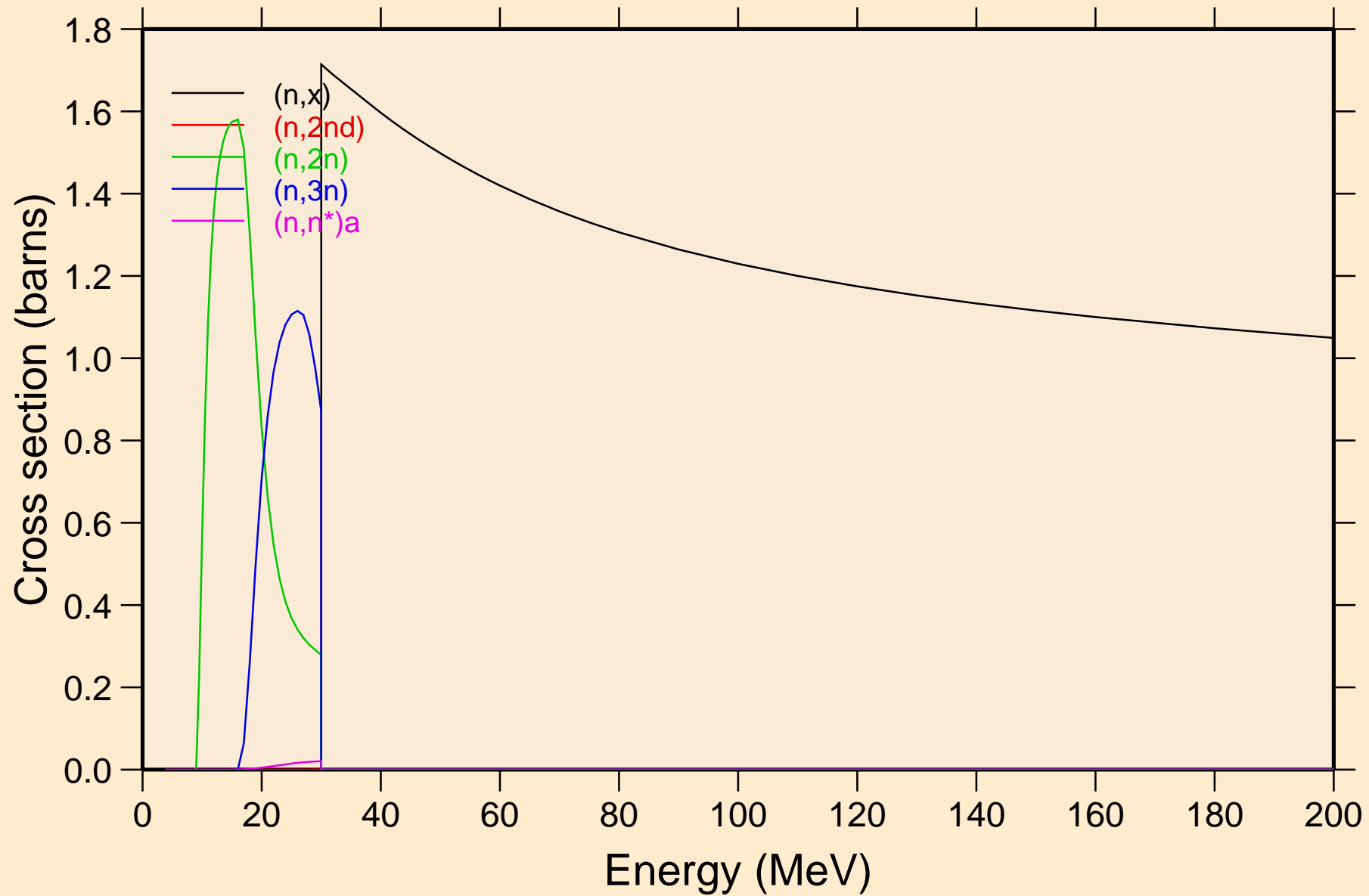

# AG111 NEUTRON ACER TENDL-2024 LIBRARY; T=293.6K

## Threshold reactions

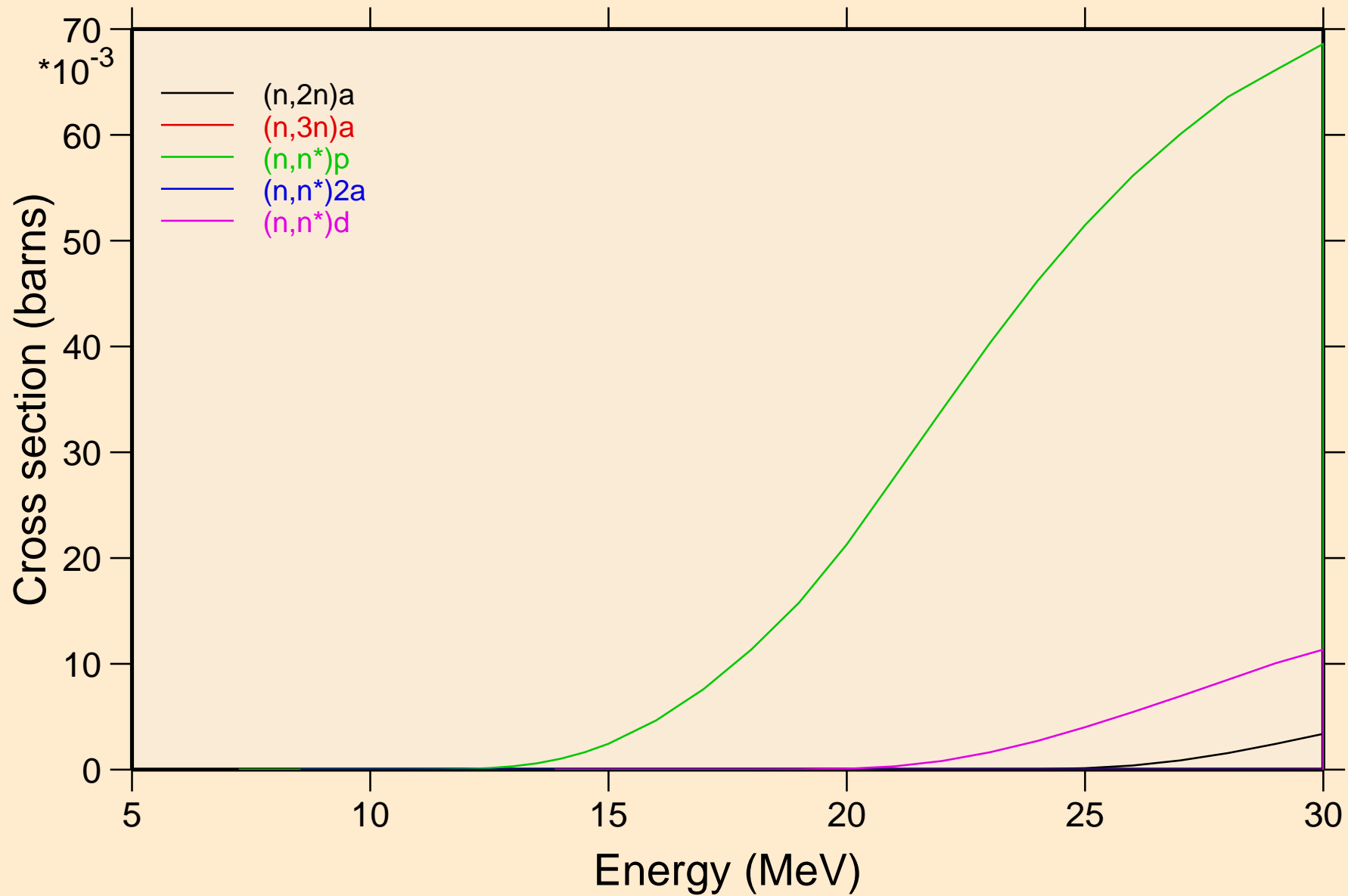

# AG111 NEUTRON ACER TENDL-2024 LIBRARY; T=293.6K

## Threshold reactions

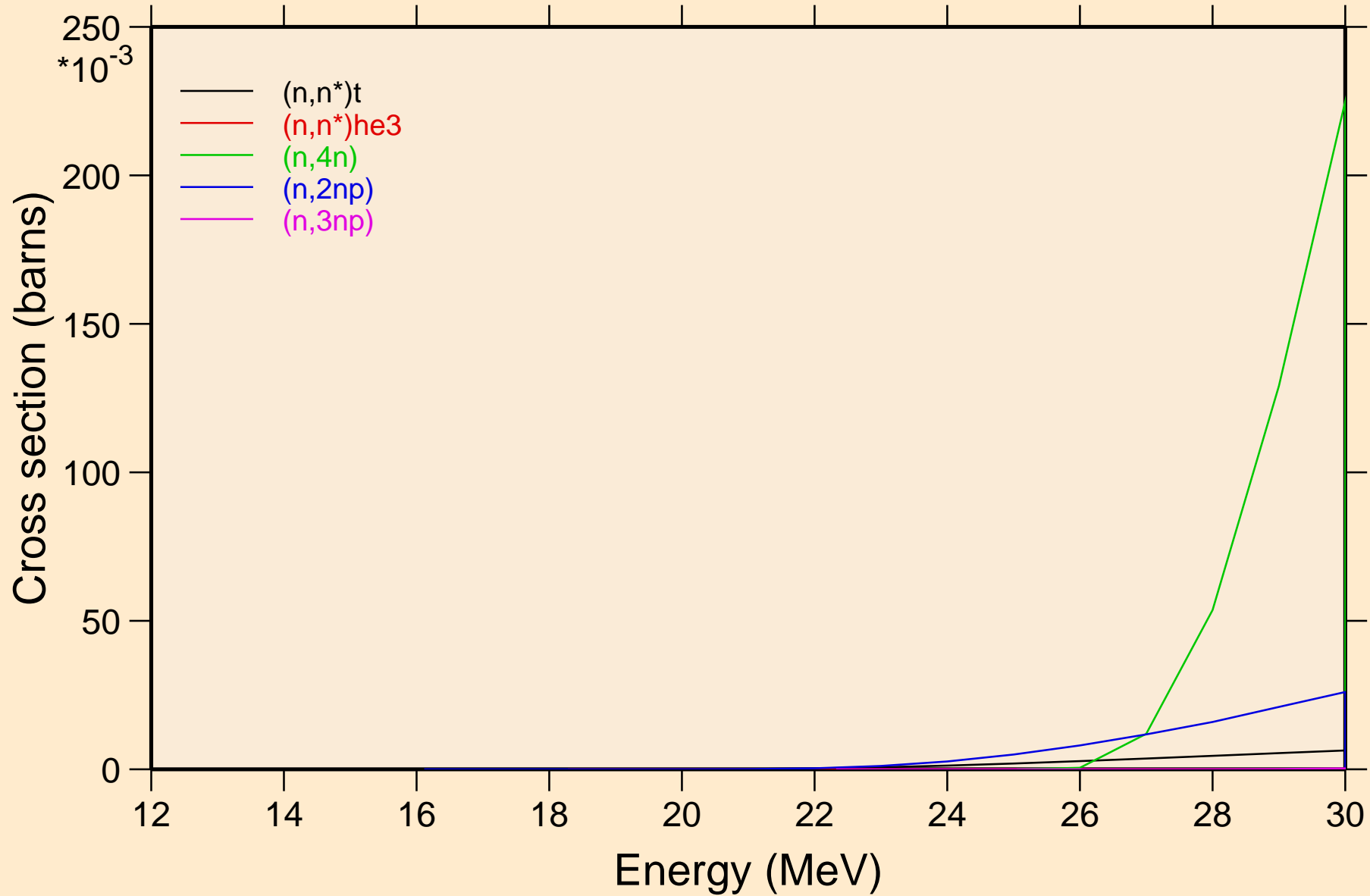

AG111 NEUTRON ACER TENDL-2024 LIBRARY; T=293.6K  
Threshold reactions

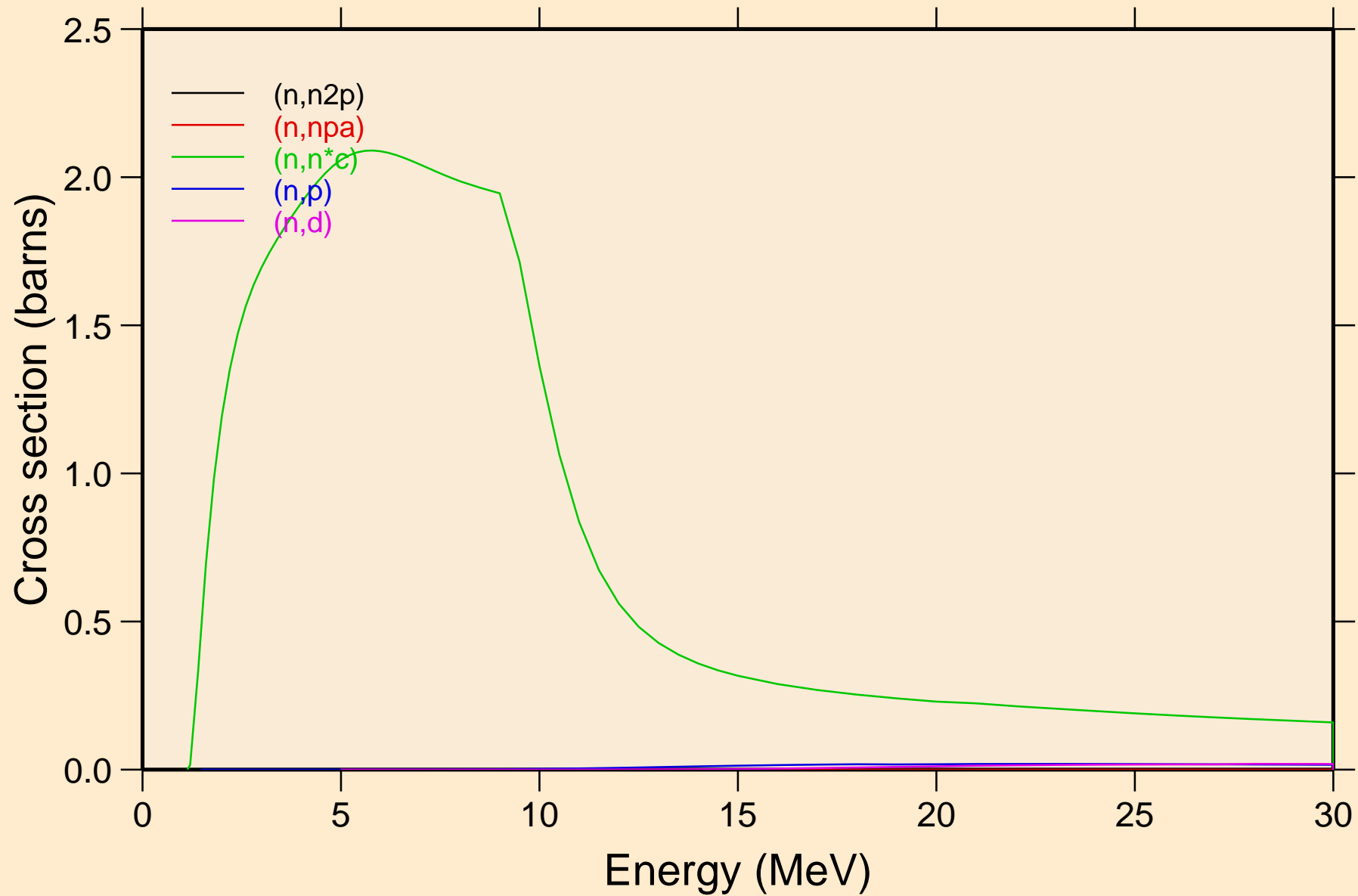

# AG111 NEUTRON ACER TENDL-2024 LIBRARY; T=293.6K

## Threshold reactions

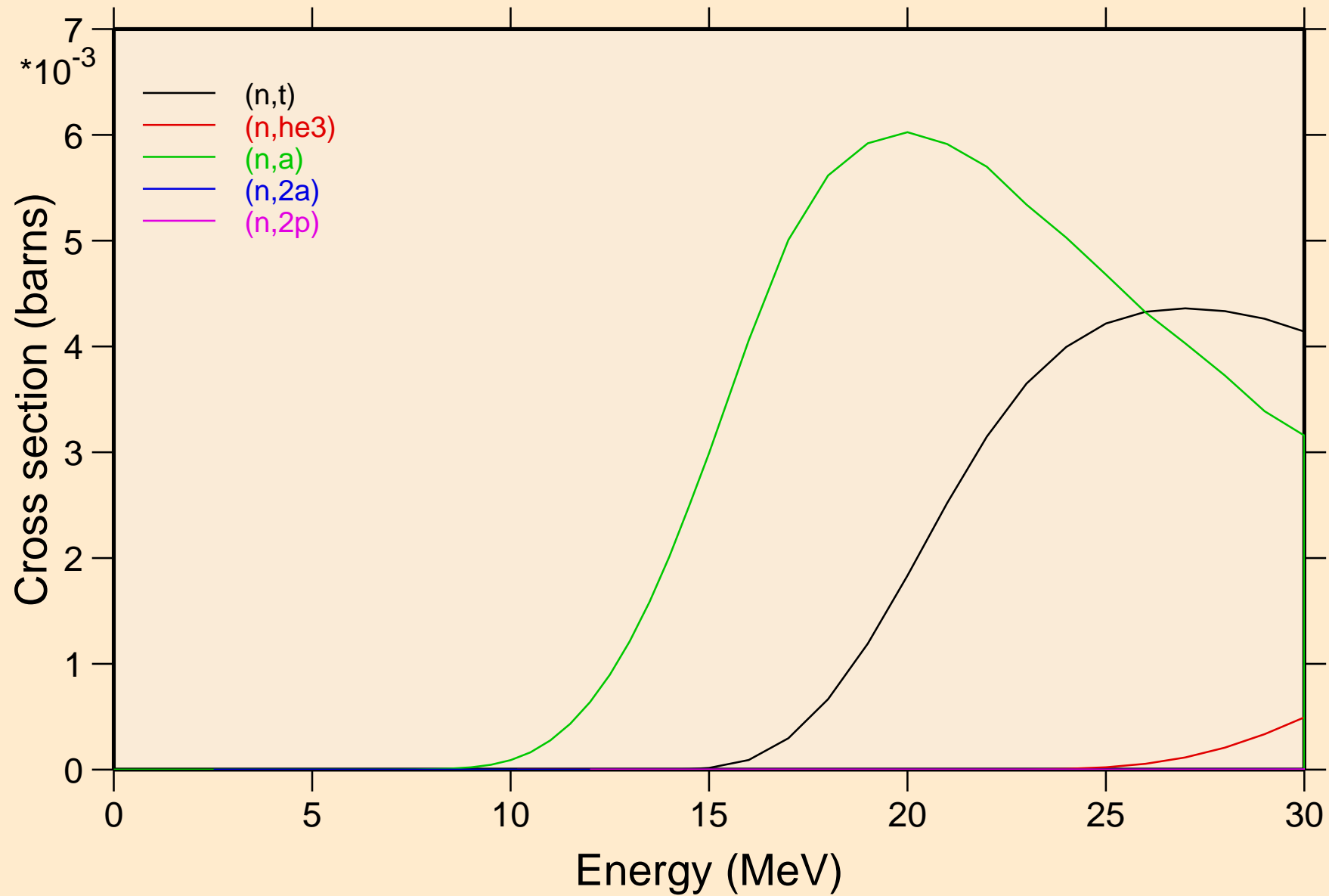

# AG111 NEUTRON ACER TENDL-2024 LIBRARY; T=293.6K

## Threshold reactions

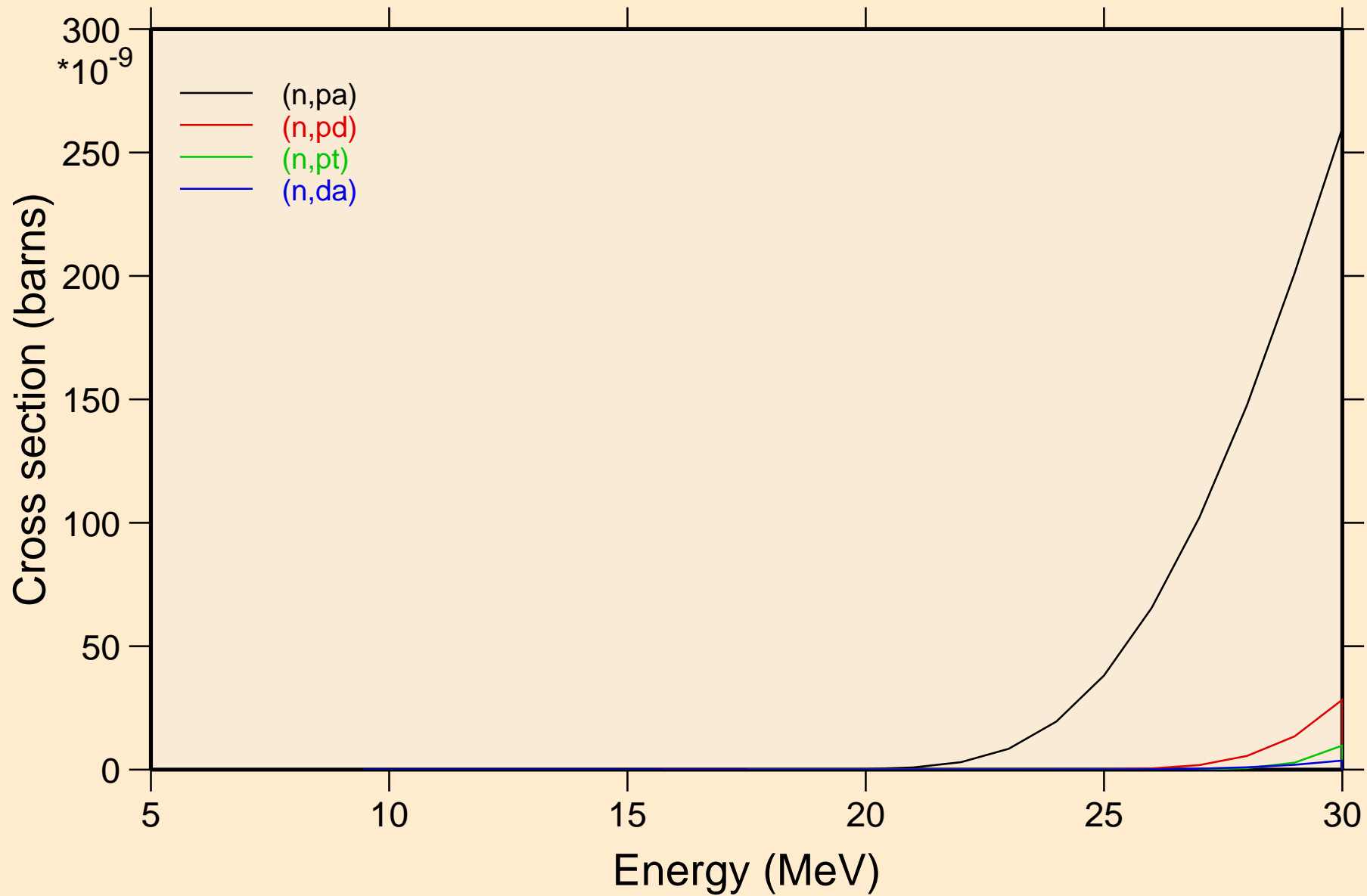

# AG111 NEUTRON ACER TENDL-2024 LIBRARY; T=293.6K

## Threshold reactions

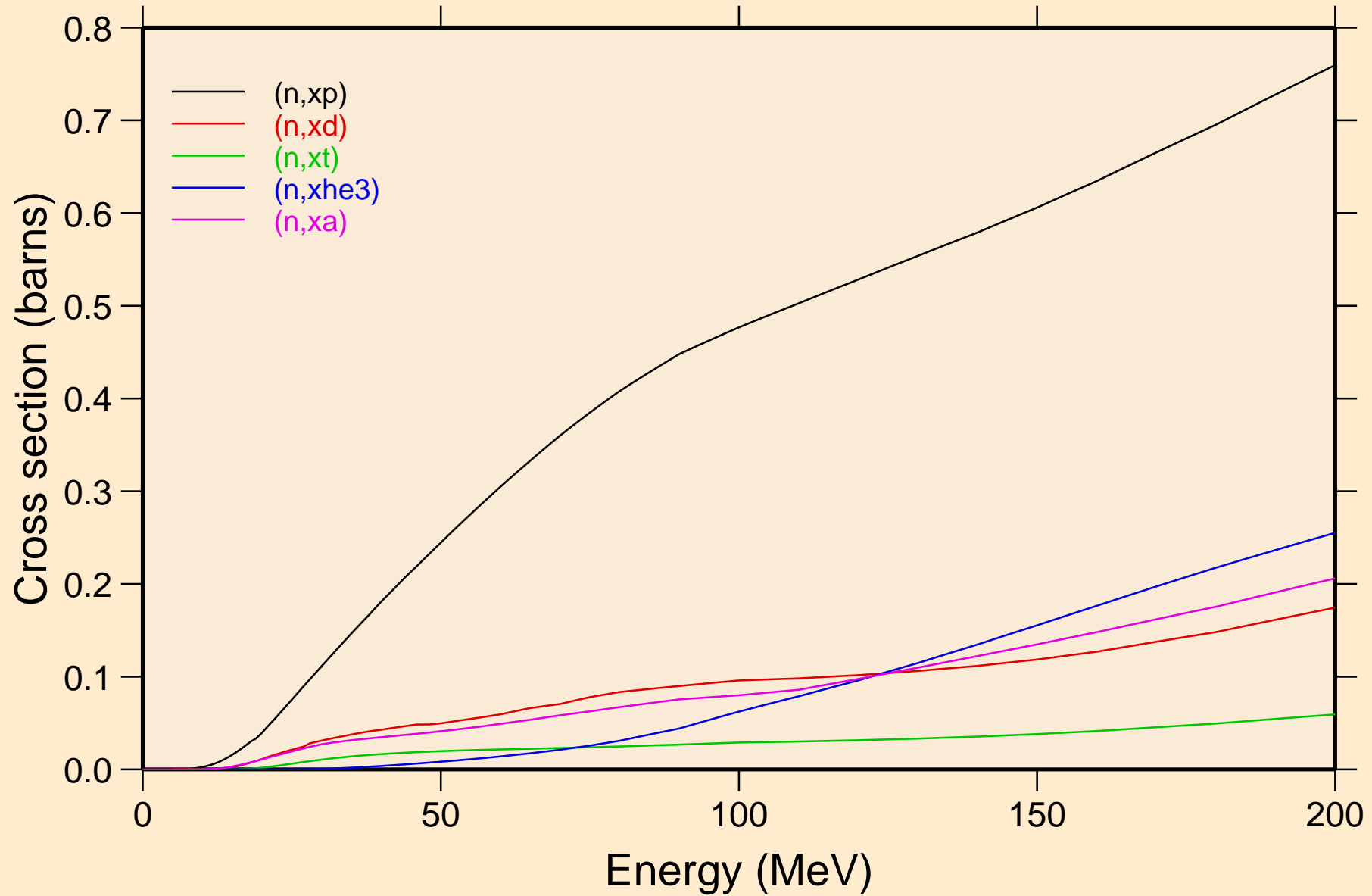

AG111 NEUTRON ACER TENDL-2024 LIBRARY; T=293.6K  
angular distribution for elastic

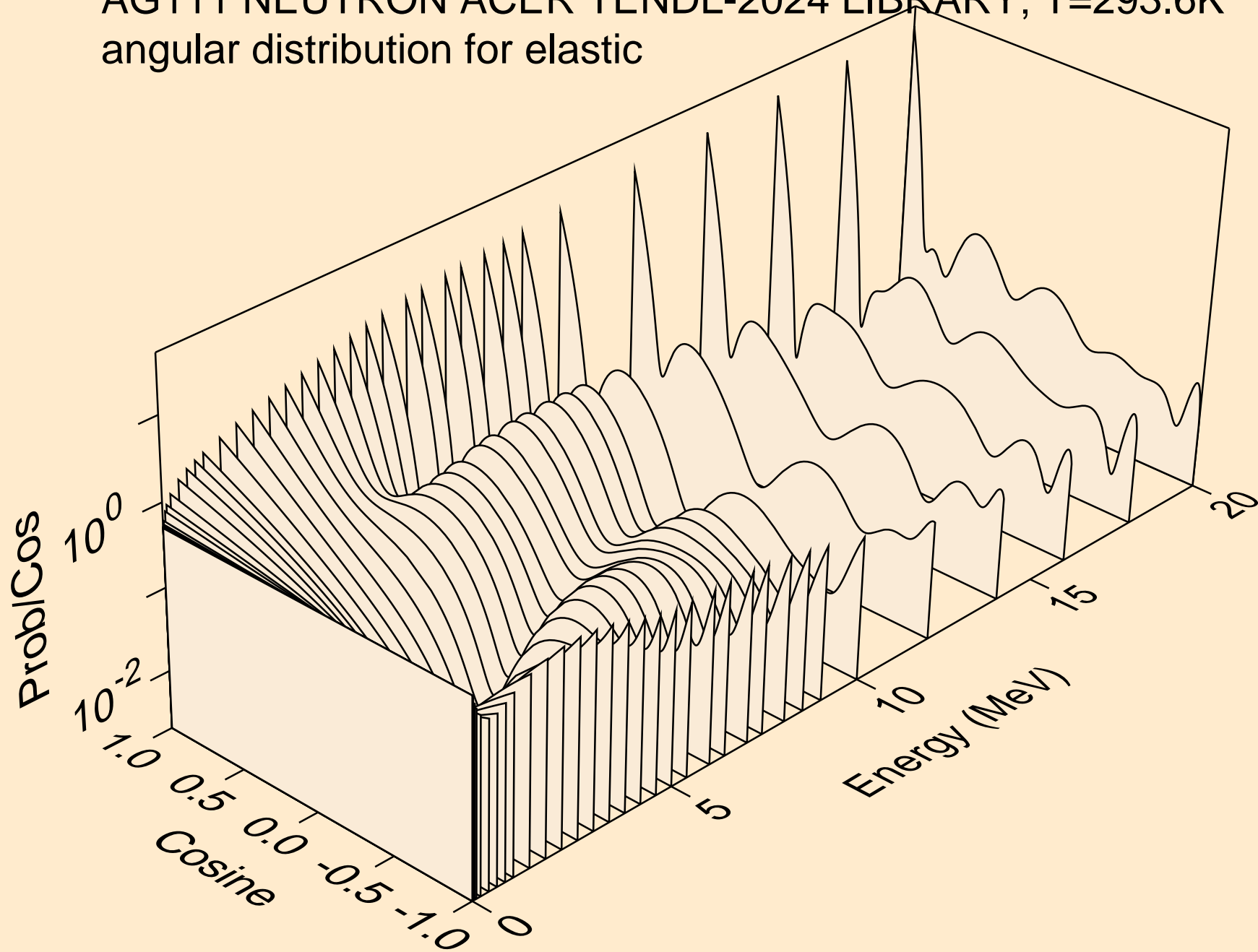

AG111 NEUTRON ACER TENDL-2024 LIBRARY; T=293.6K  
angular distribution for elastic

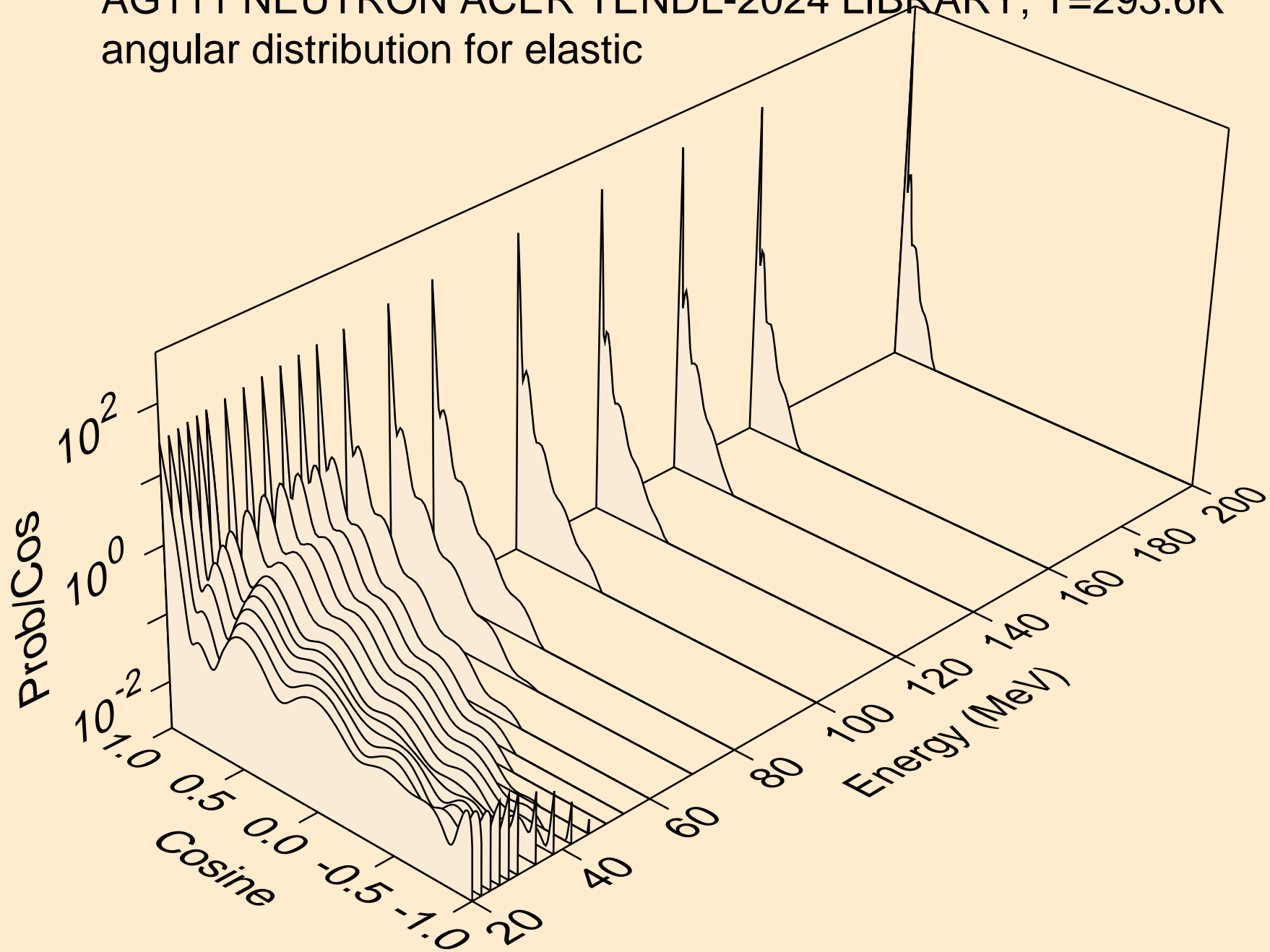

AG111 NEUTRON ACER TENDL-2024 LIBRARY; T=293.6K  
angular distribution for (n,n\*1)

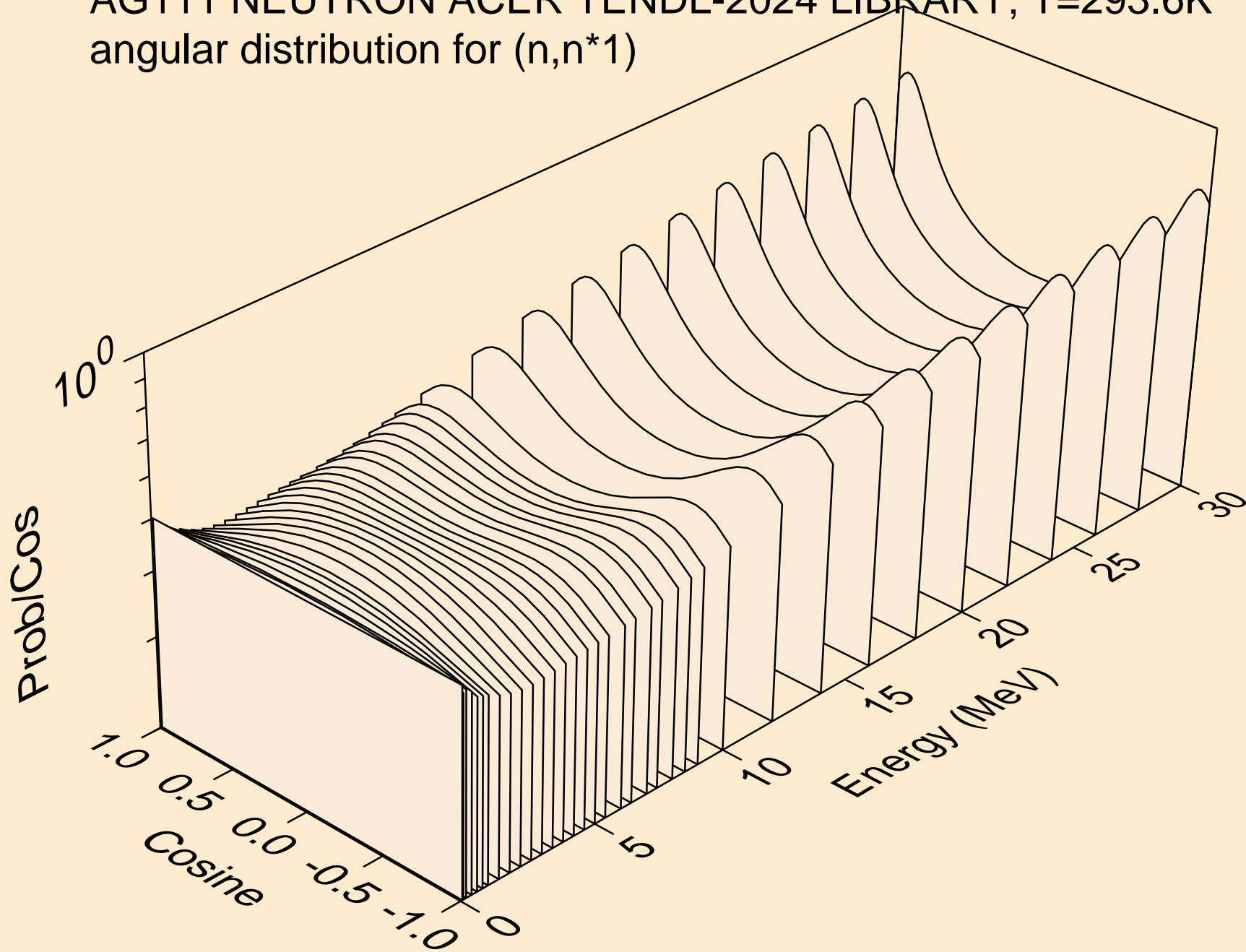

AG111 NEUTRON ACER TENDL-2024 LIBRARY; T=293.6K  
angular distribution for (n,n\*2)

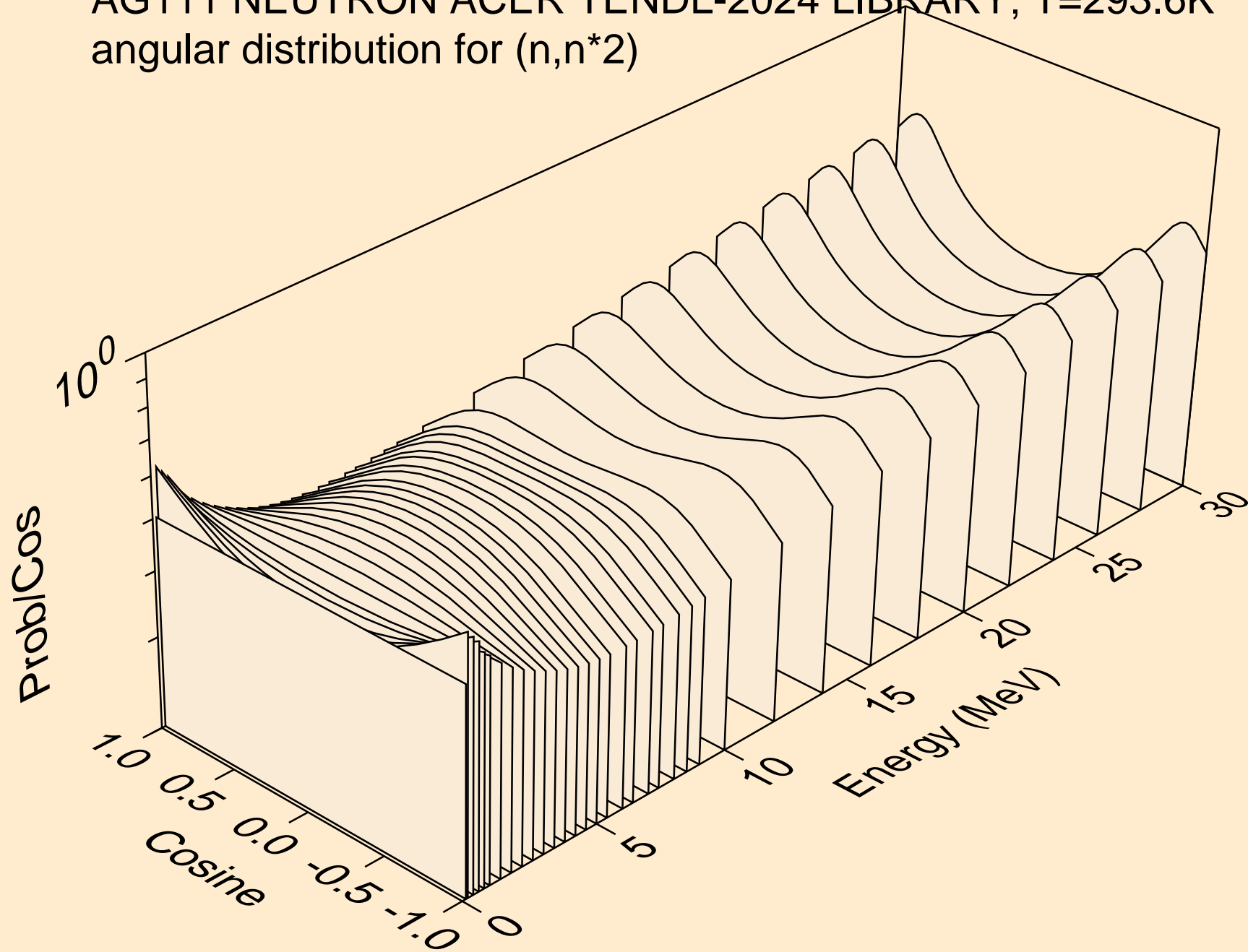

AG111 NEUTRON ACER TENDL-2024 LIBRARY; T=293.6K  
angular distribution for (n,n\*3)

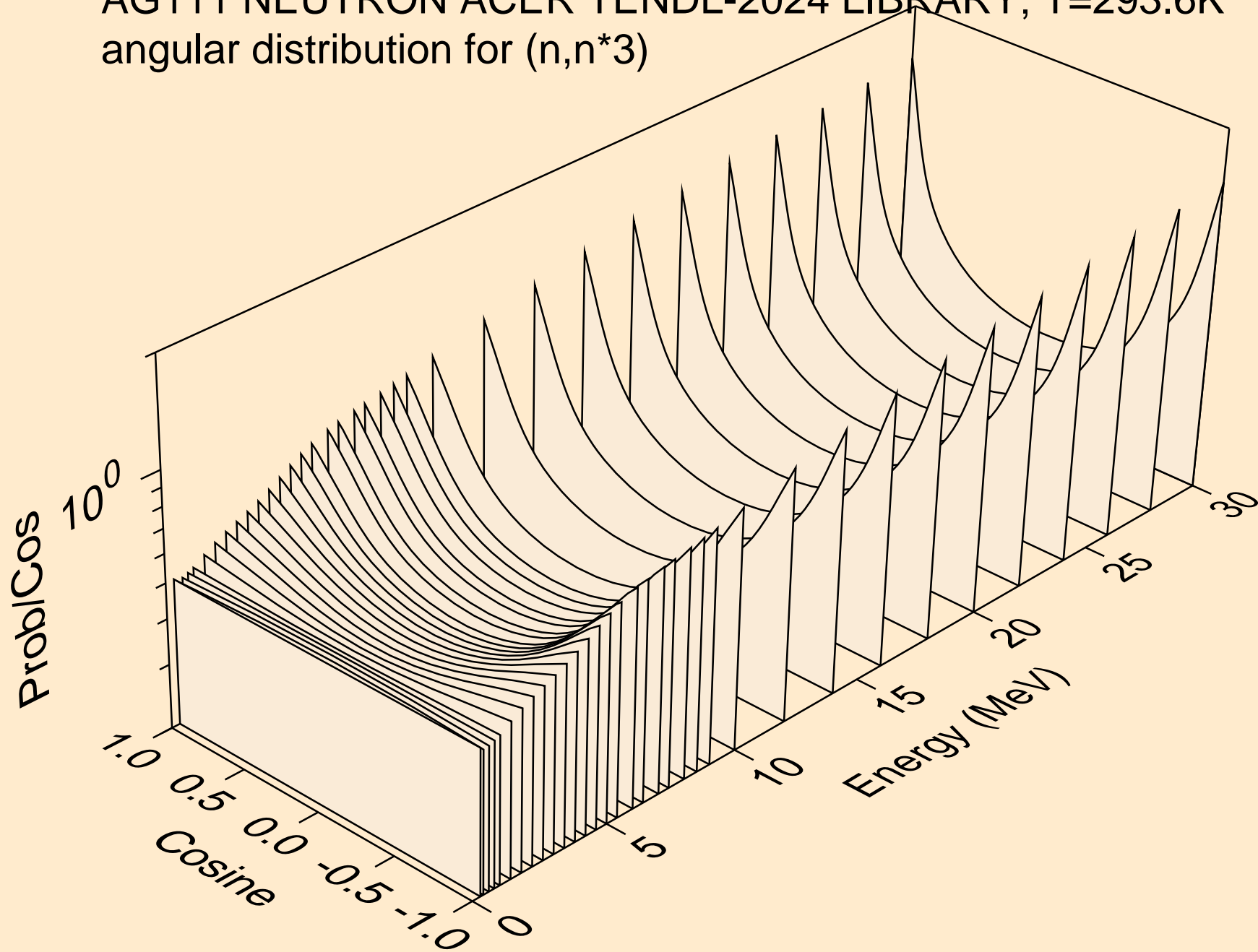

AG111 NEUTRON ACER TENDL-2024 LIBRARY; T=293.6K  
angular distribution for (n,n\*4)

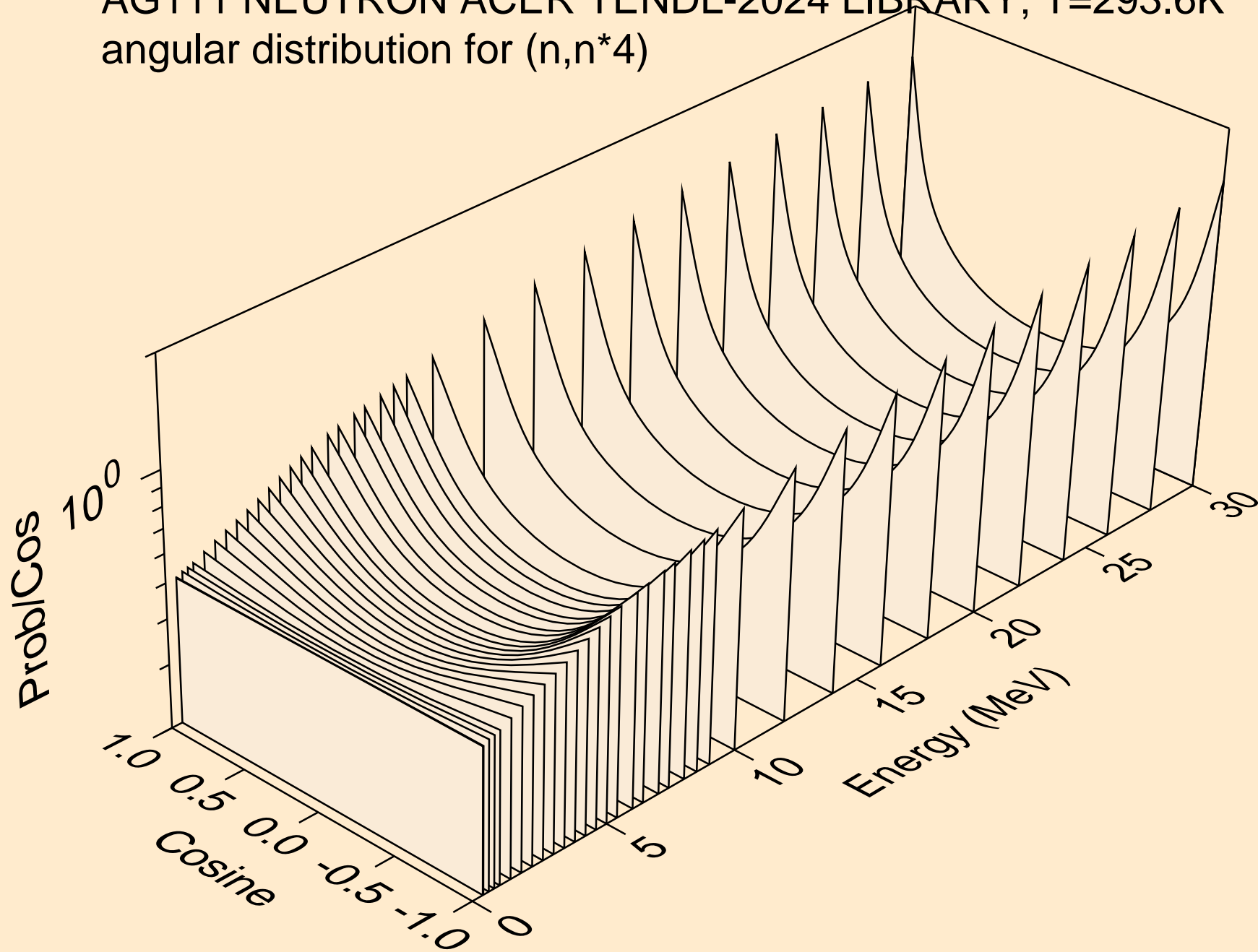

AG111 NEUTRON ACER TENDL-2024 LIBRARY; T=293.6K  
angular distribution for (n,n\*5)

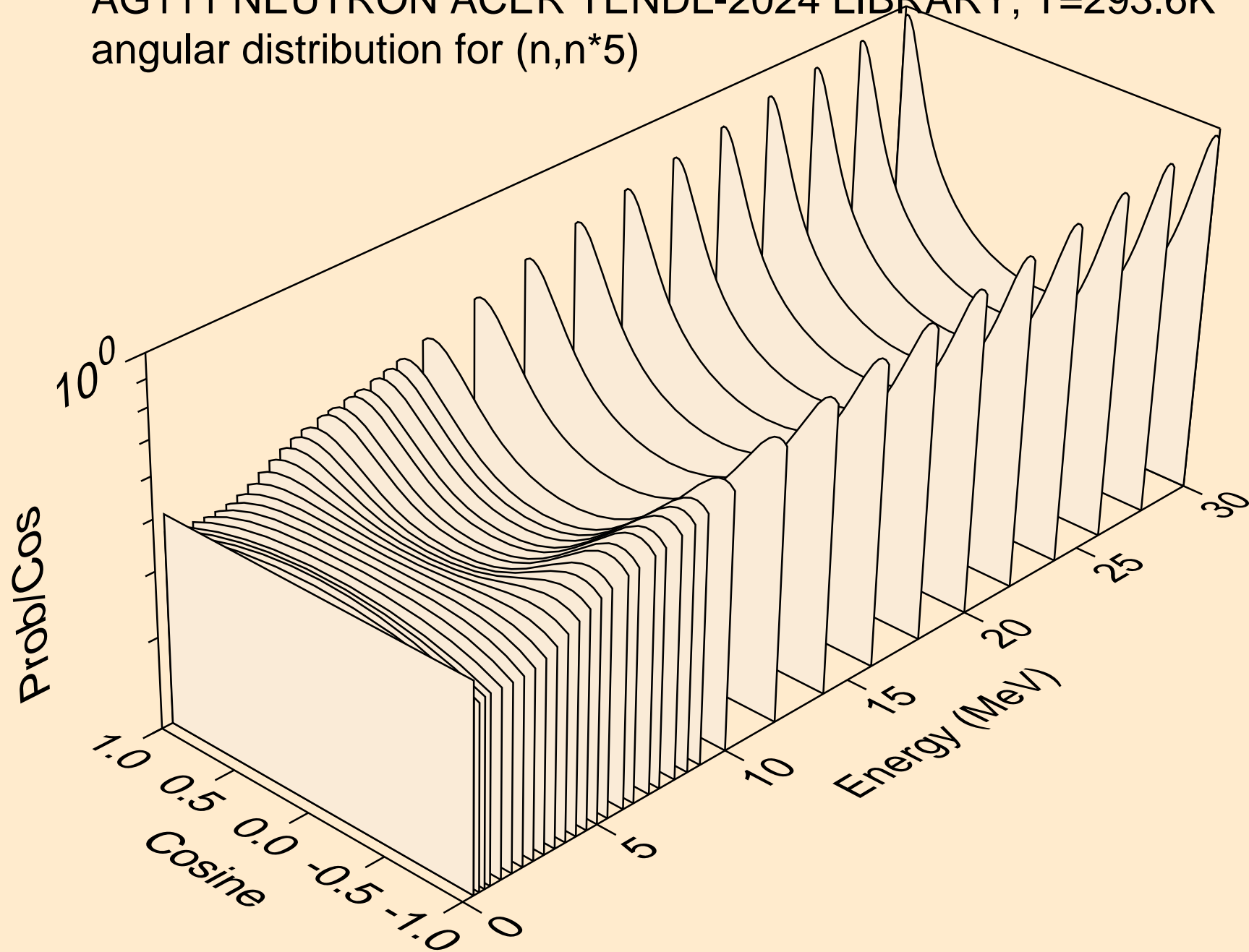

AG111 NEUTRON ACER TENDL-2024 LIBRARY; T=293.6K  
angular distribution for (n,n\*6)

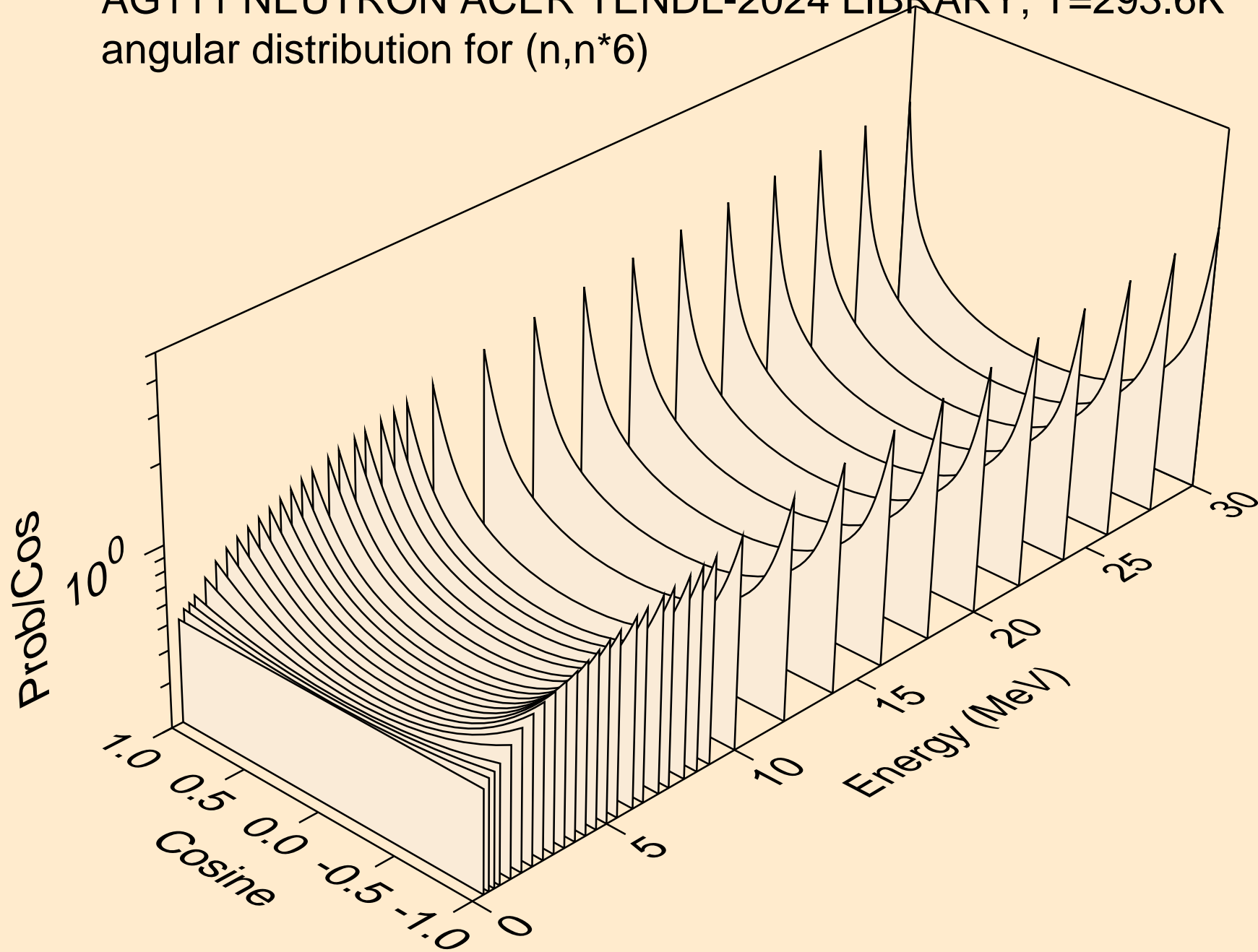

AG111 NEUTRON ACER TENDL-2024 LIBRARY; T=293.6K  
angular distribution for (n,n\*7)

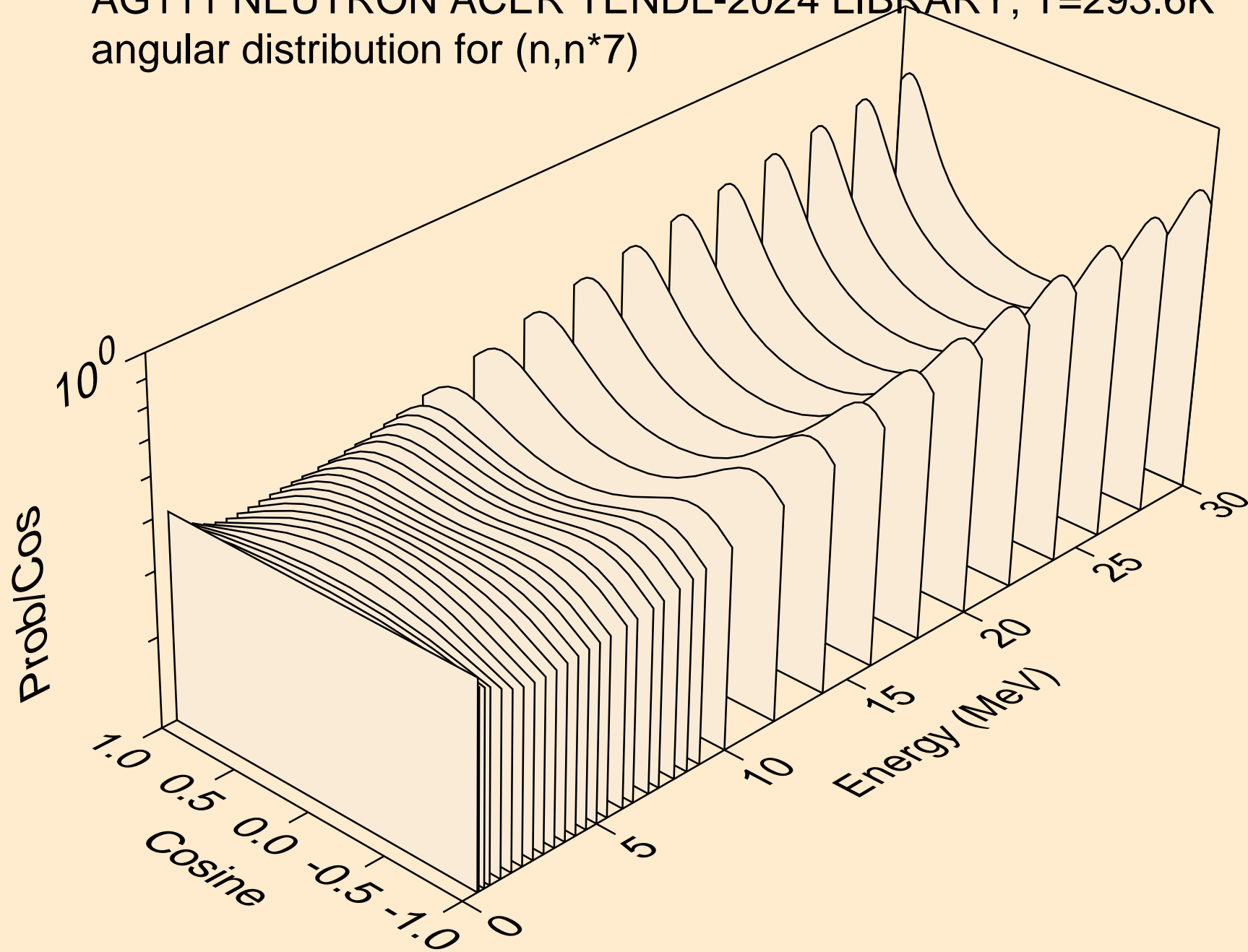

AG111 NEUTRON ACER TENDL-2024 LIBRARY; T=293.6K  
angular distribution for (n,n\*8)

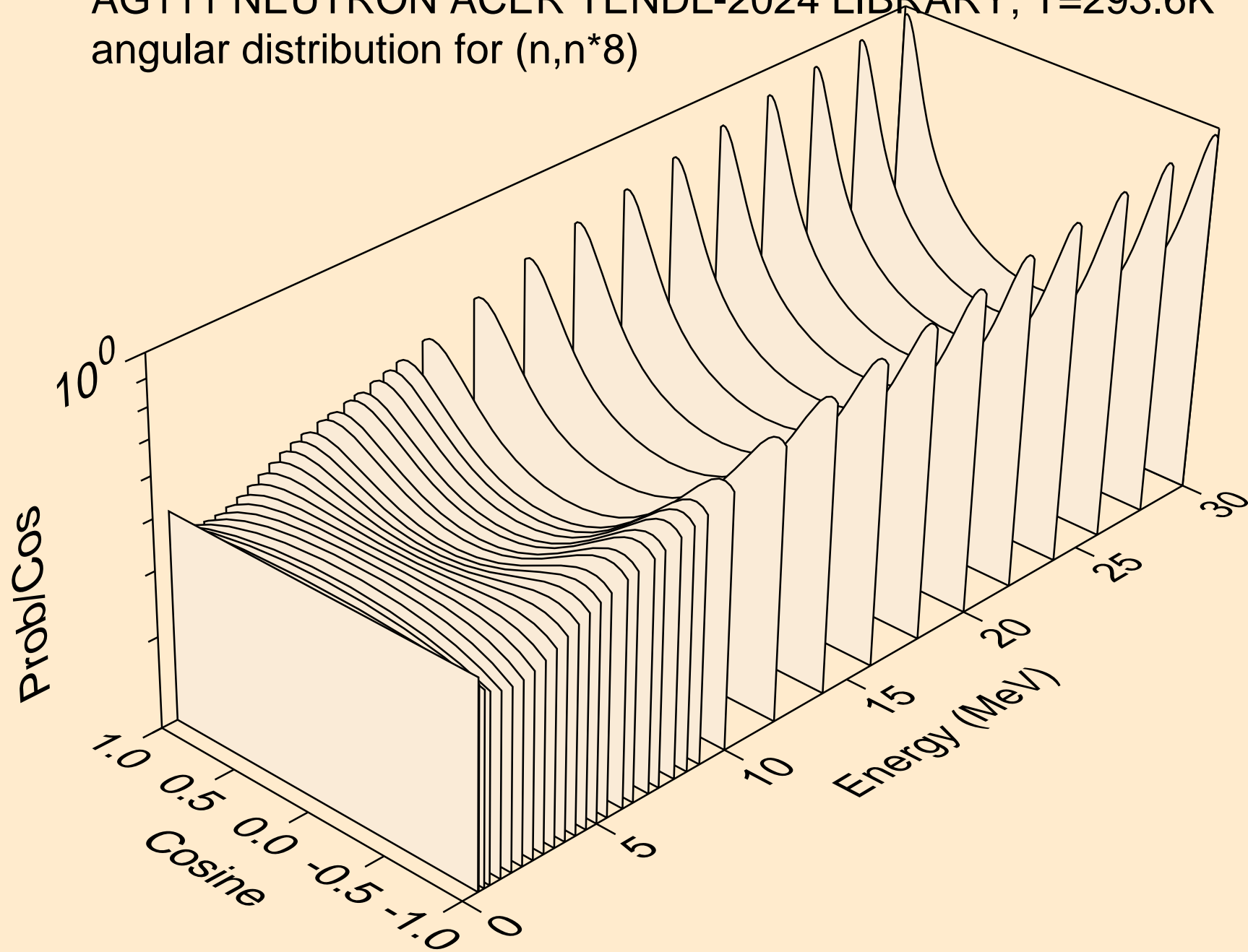

AG111 NEUTRON ACER TENDL-2024 LIBRARY; T=293.6K  
angular distribution for (n,n\*9)

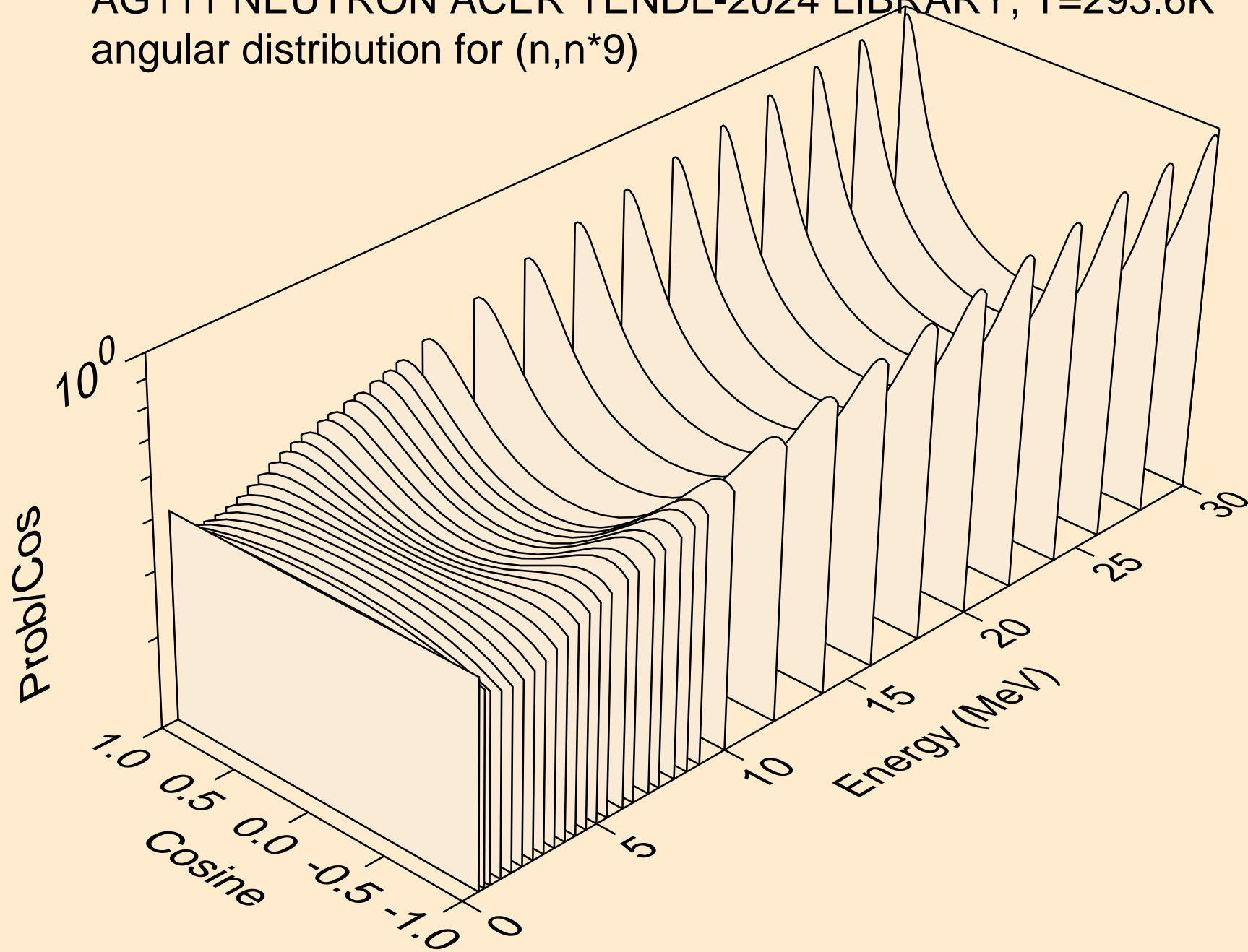

AG111 NEUTRON ACER TENDL-2024 LIBRARY; T=293.6K  
angular distribution for (n,n\*10)

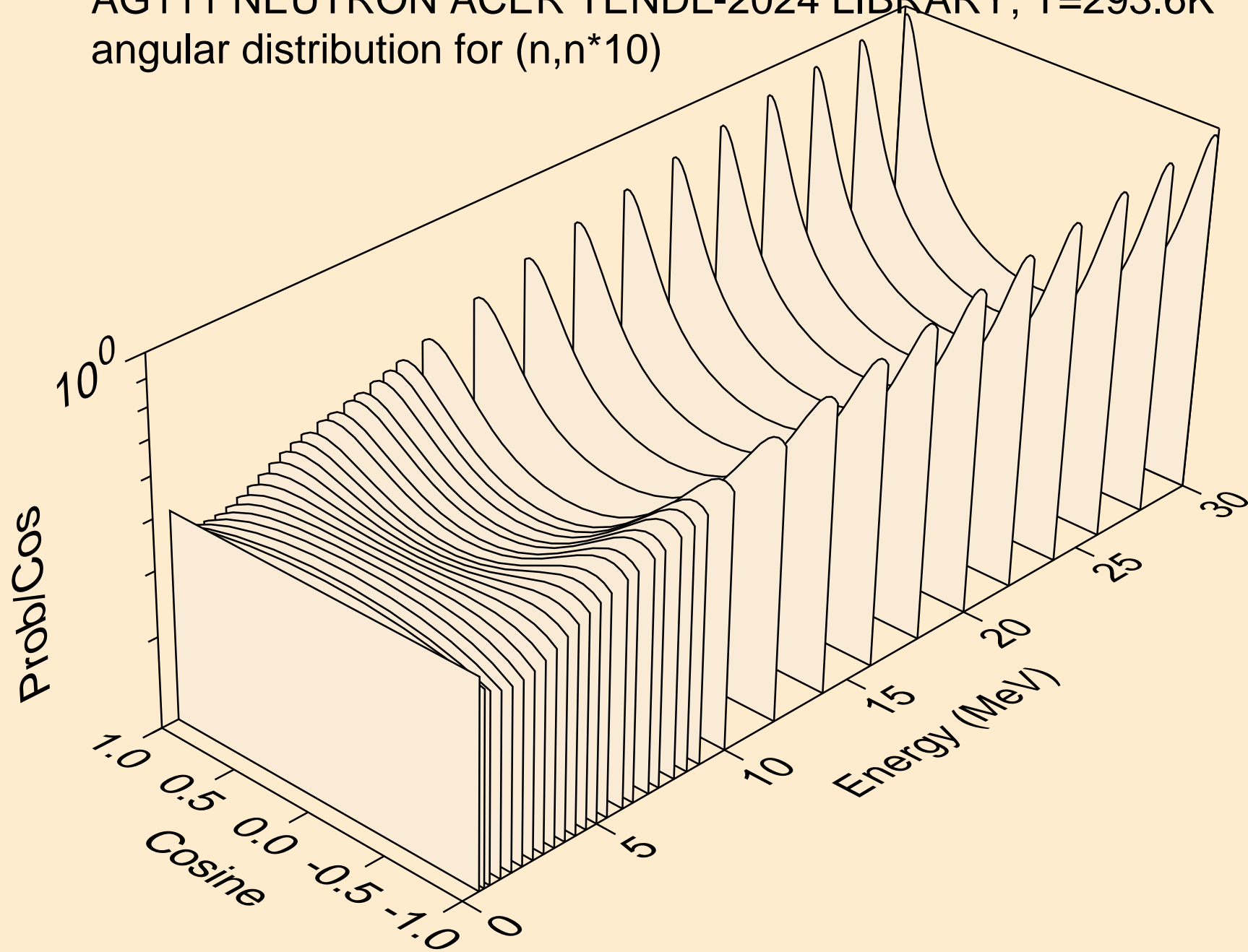

AG111 NEUTRON ACER TENDL-2024 LIBRARY; T=293.6K  
angular distribution for (n,n\*11)

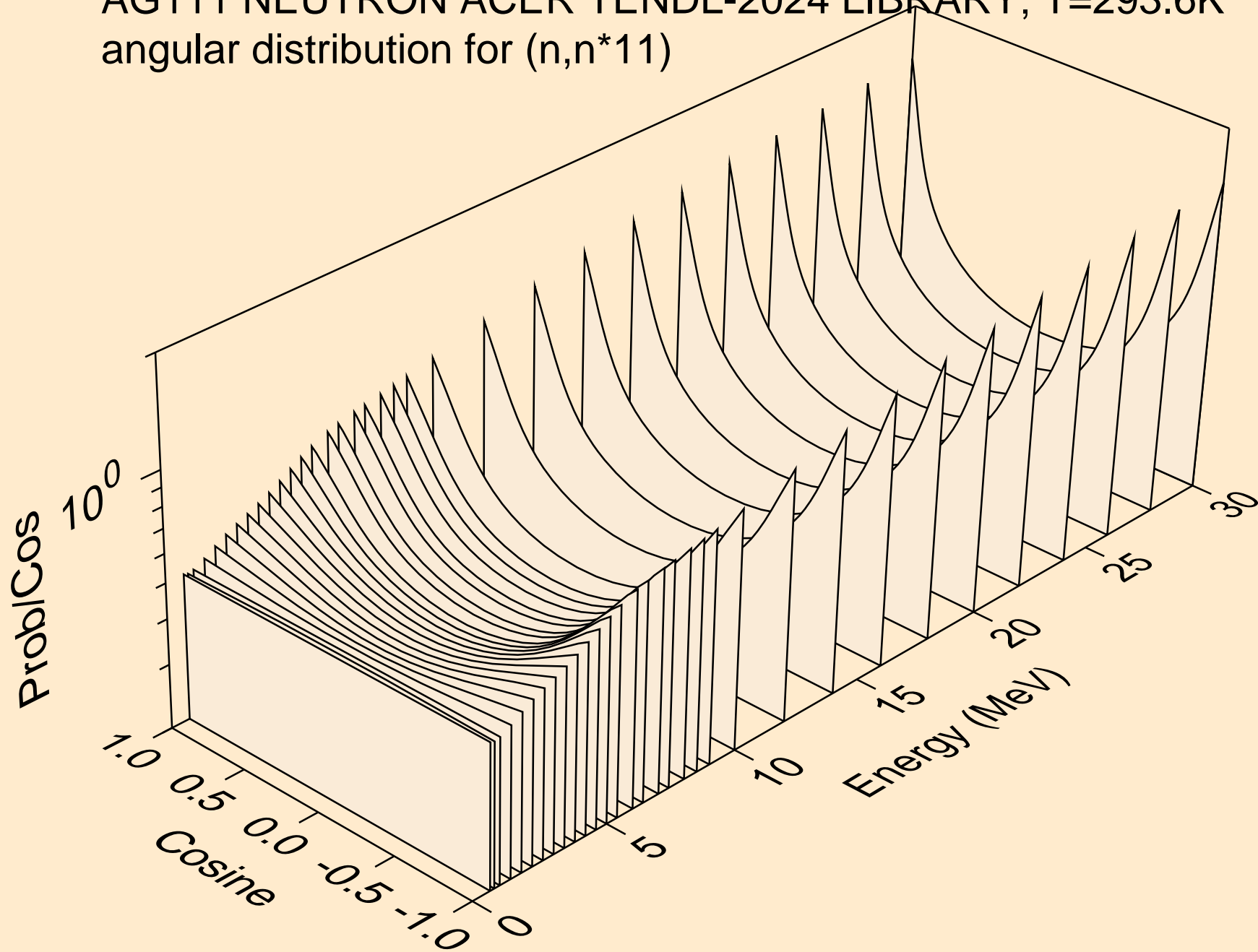

AG111 NEUTRON ACER TENDL-2024 LIBRARY; T=293.6K  
angular distribution for (n,n\*12)

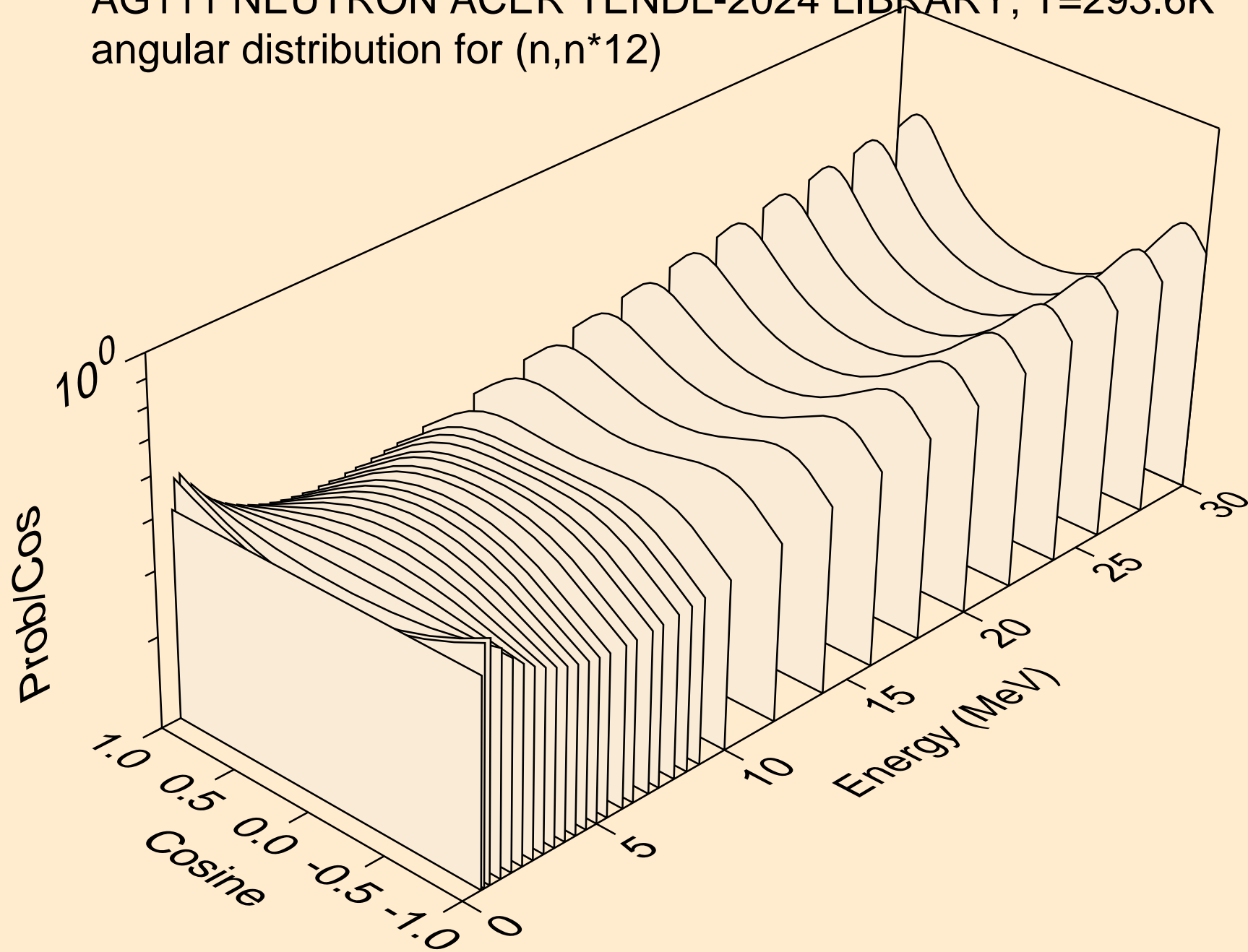

AG111 NEUTRON ACER TENDL-2024 LIBRARY; T=293.6K  
angular distribution for (n,n\*13)

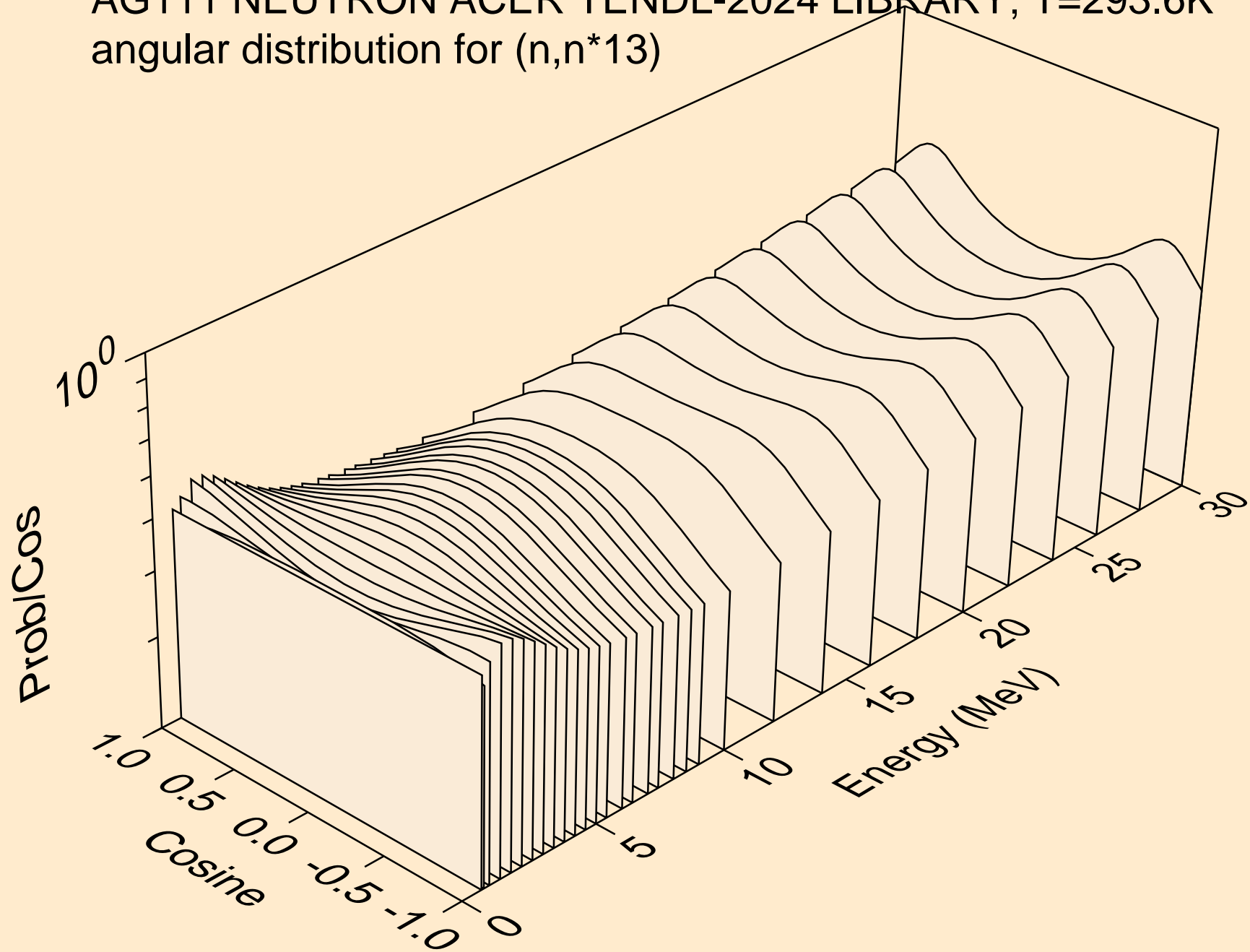

AG111 NEUTRON ACER TENDL-2024 LIBRARY; T=293.6K  
angular distribution for (n,n\*14)

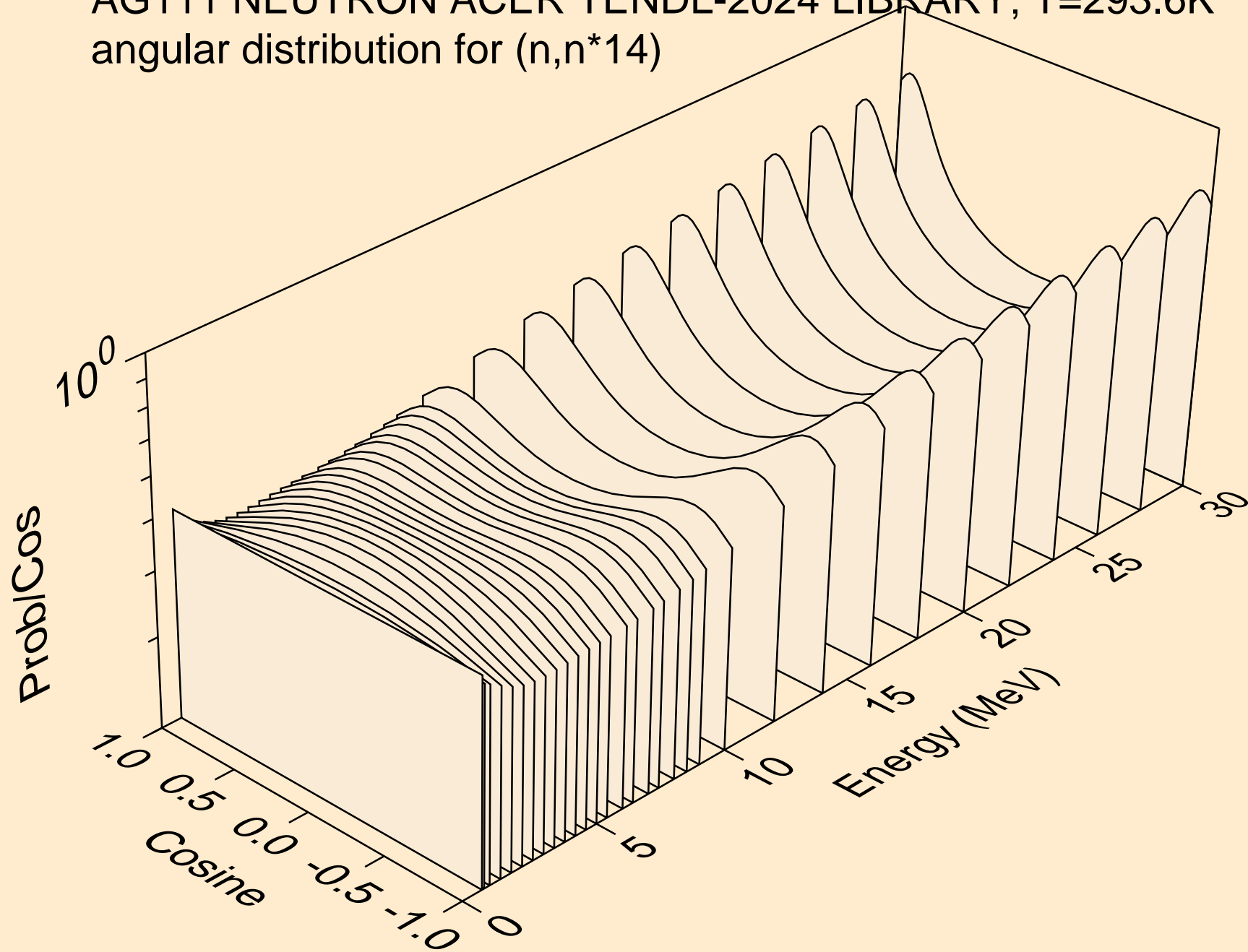

AG111 NEUTRON ACER TENDL-2024 LIBRARY; T=293.6K  
angular distribution for (n,n\*15)

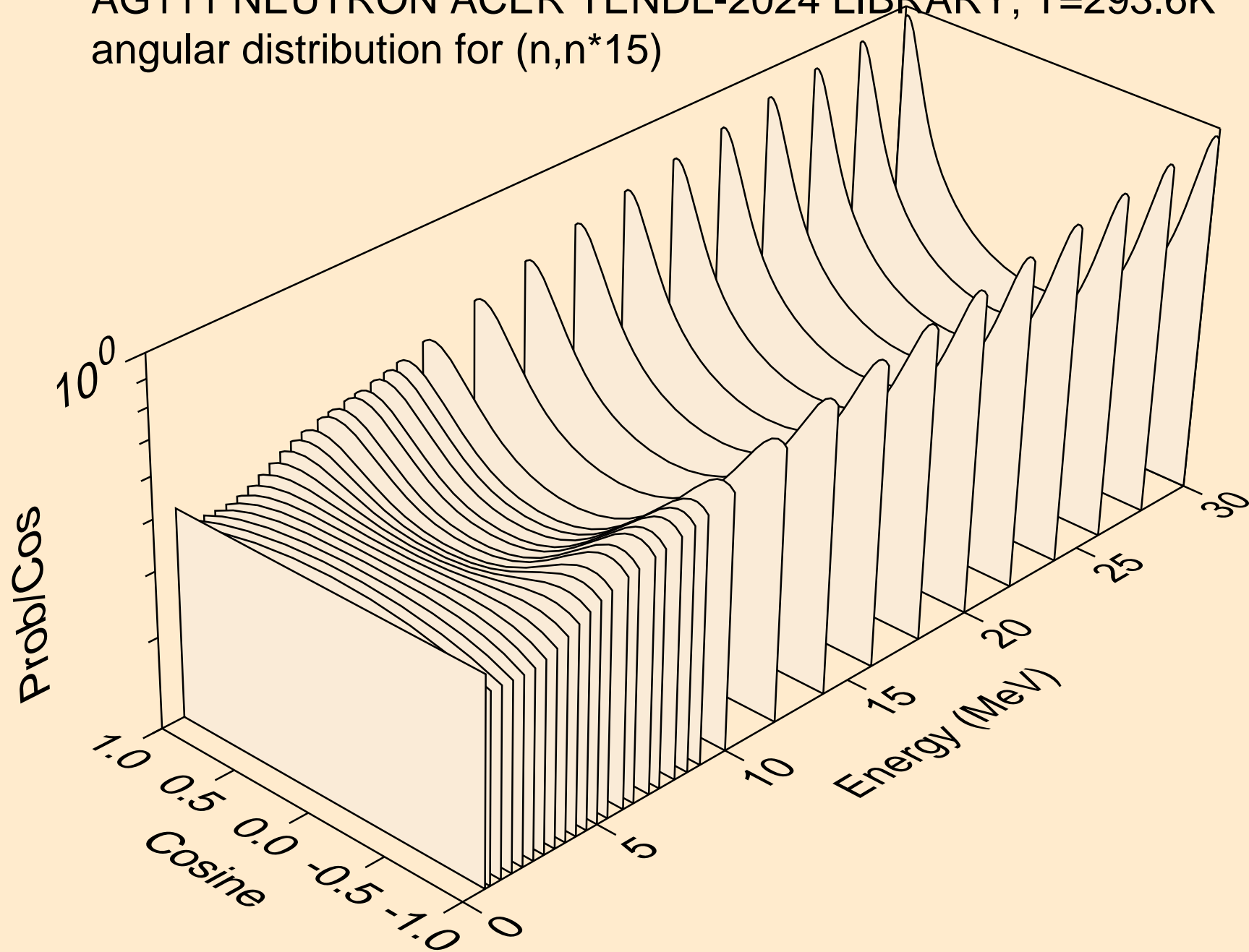

AG111 NEUTRON ACER TENDL-2024 LIBRARY; T=293.6K  
angular distribution for (n,n\*16)

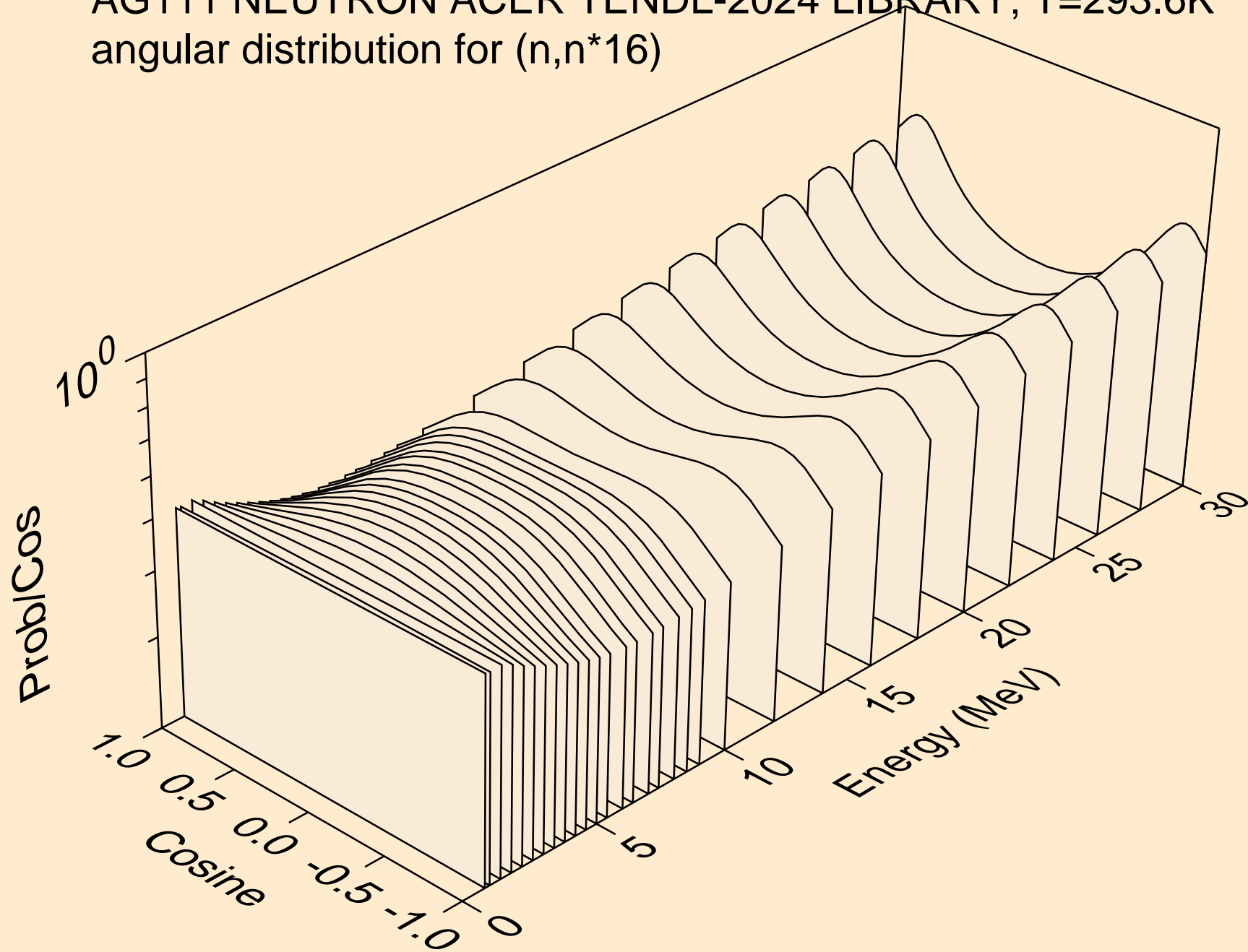

AG111 NEUTRON ACER TENDL-2024 LIBRARY; T=293.6K  
angular distribution for (n,n\*17)

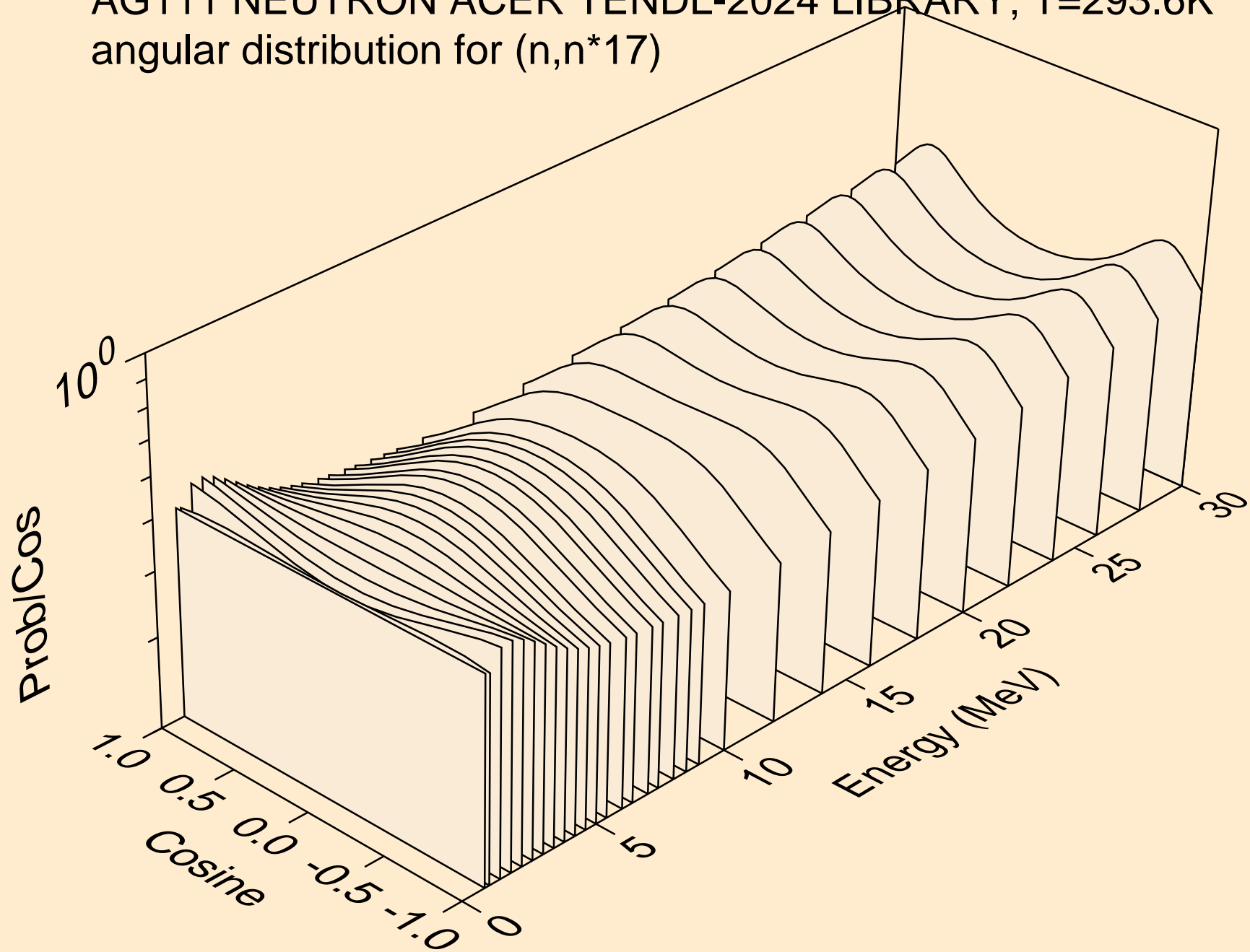

AG111 NEUTRON ACER TENDL-2024 LIBRARY; T=293.6K  
angular distribution for (n,n\*18)

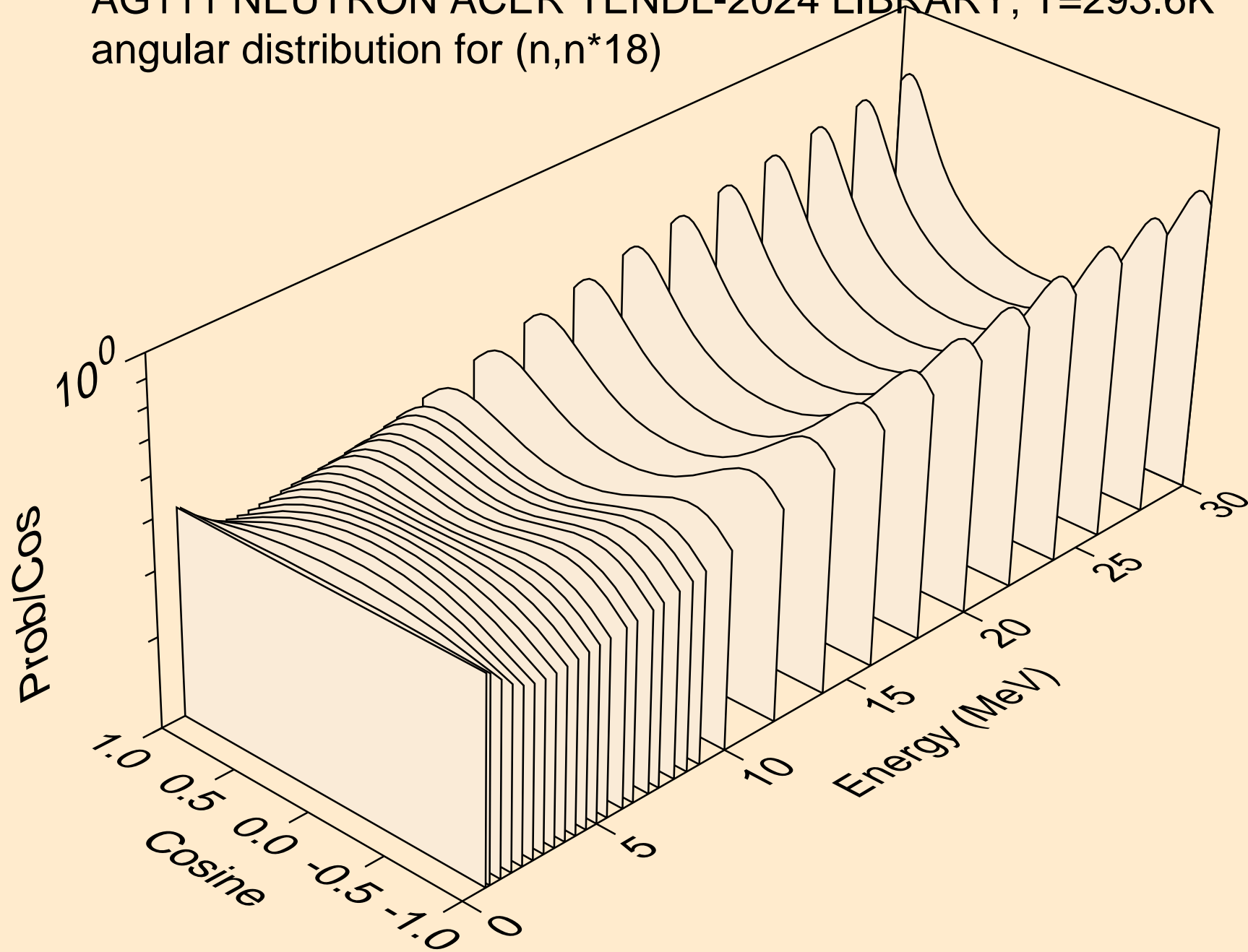

AG111 NEUTRON ACER TENDL-2024 LIBRARY; T=293.6K  
angular distribution for (n,n\*19)

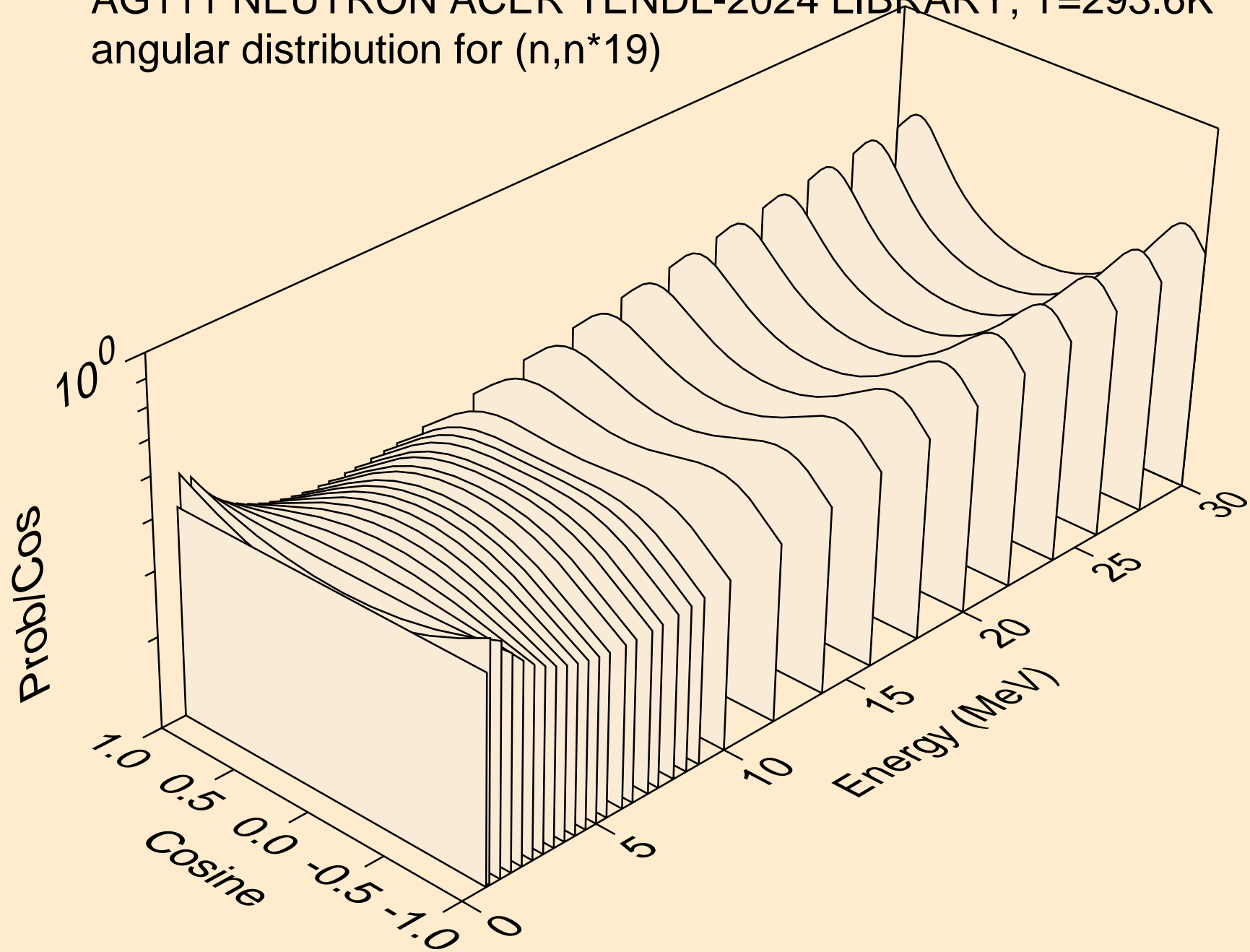

AG111 NEUTRON ACER TENDL-2024 LIBRARY; T=293.6K  
angular distribution for (n,n\*20)

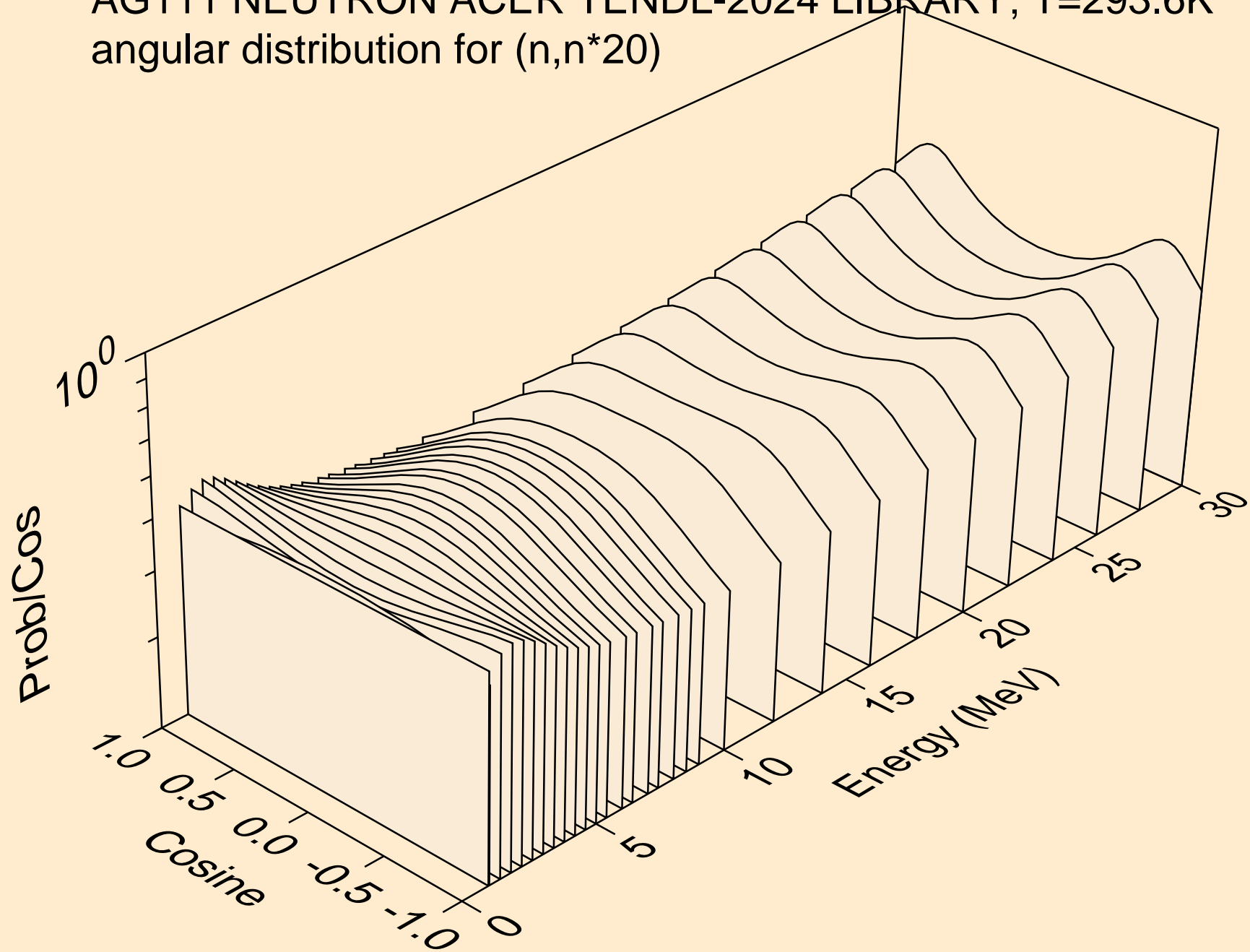

AG111 NEUTRON ACER TENDL-2024 LIBRARY; T=293.6K  
angular distribution for (n,n\*21)

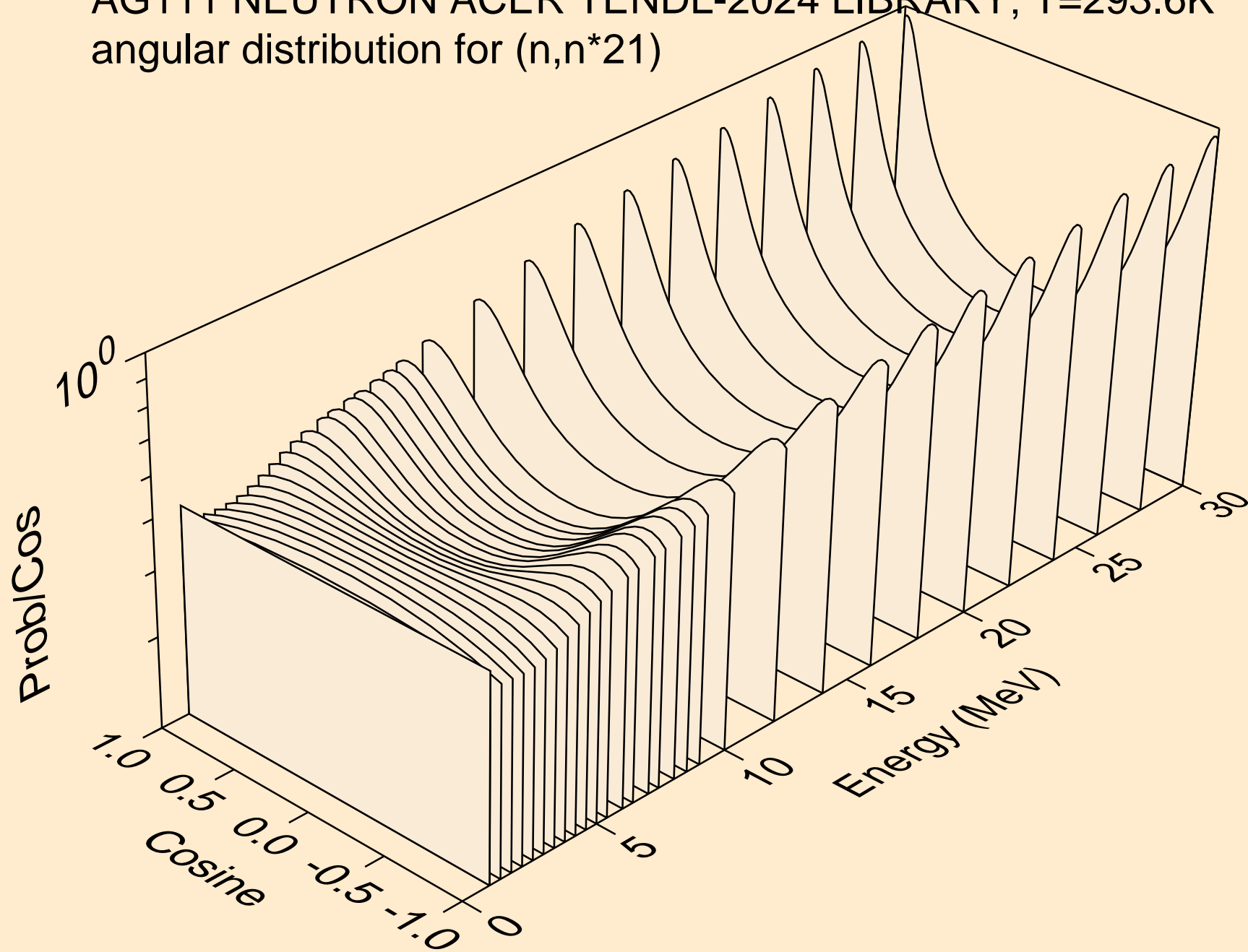

AG111 NEUTRON ACER TENDL-2024 LIBRARY; T=293.6K  
angular distribution for (n,n\*22)

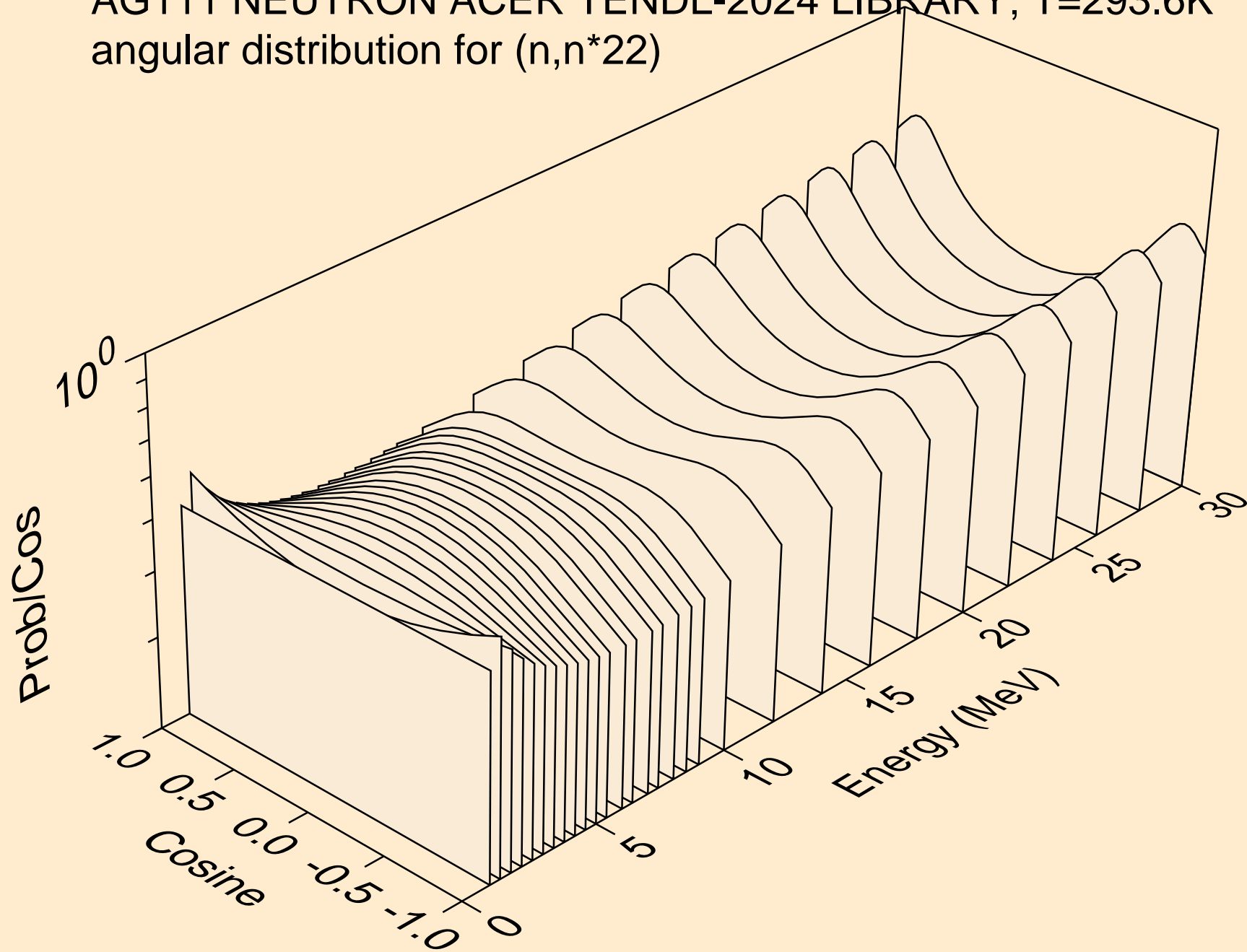

AG111 NEUTRON ACER TENDL-2024 LIBRARY; T=293.6K  
angular distribution for (n,n\*23)

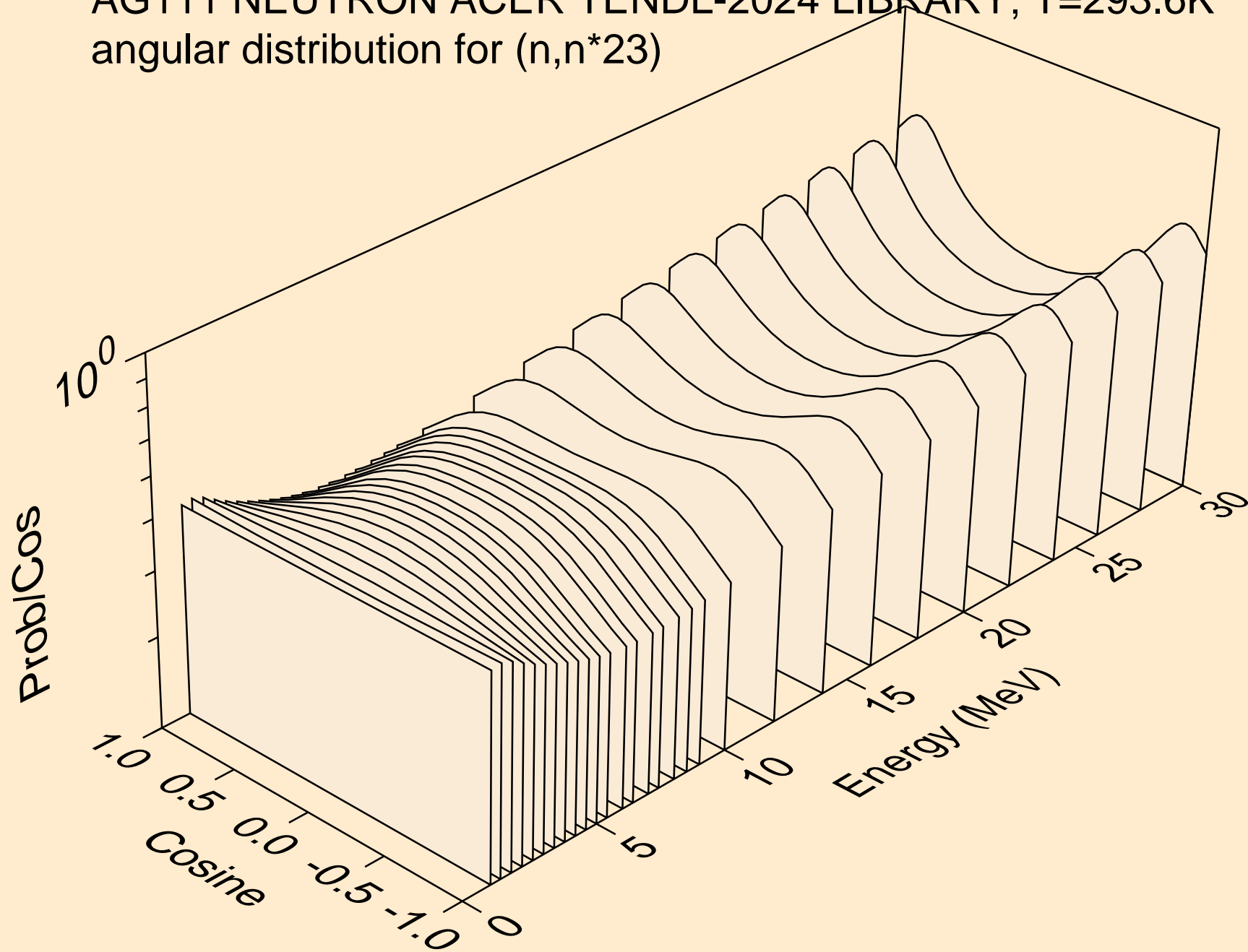

AG111 NEUTRON ACER TENDL-2024 LIBRARY; T=293.6K  
angular distribution for (n,n\*24)

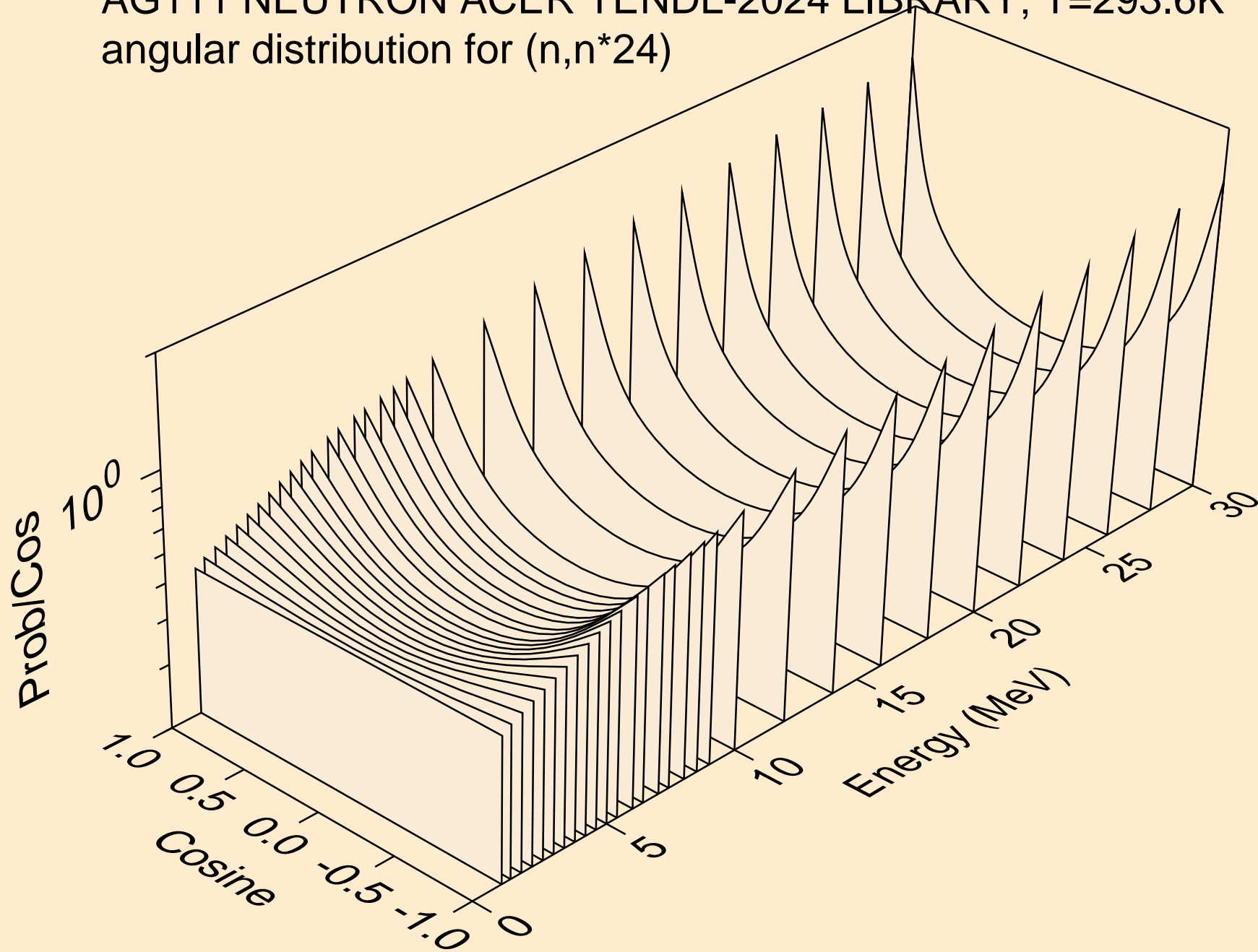

AG111 NEUTRON ACER TENDL-2024 LIBRARY; T=293.6K  
angular distribution for (n,n\*25)

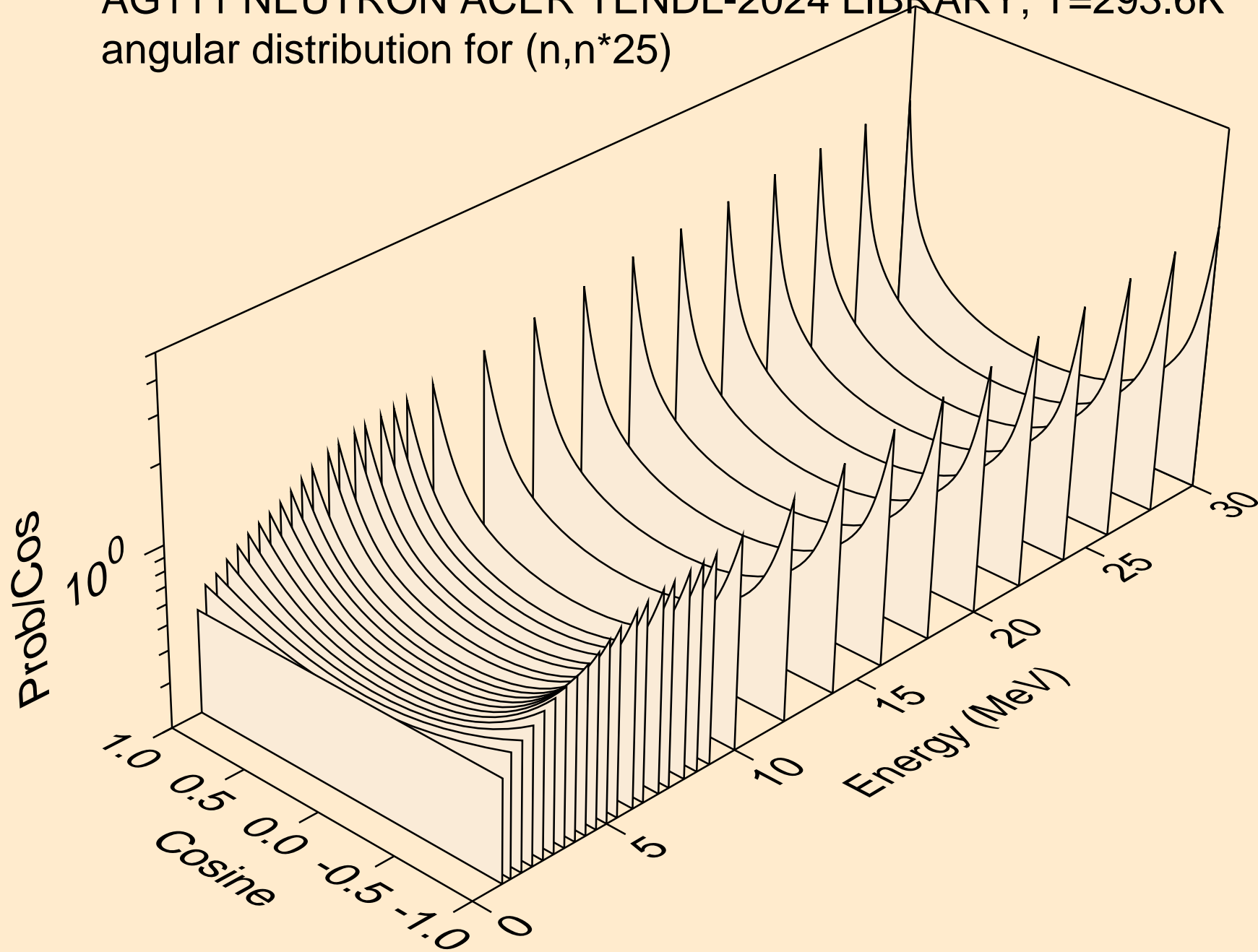

AG111 NEUTRON ACER TENDL-2024 LIBRARY; T=293.6K  
angular distribution for (n,n\*26)

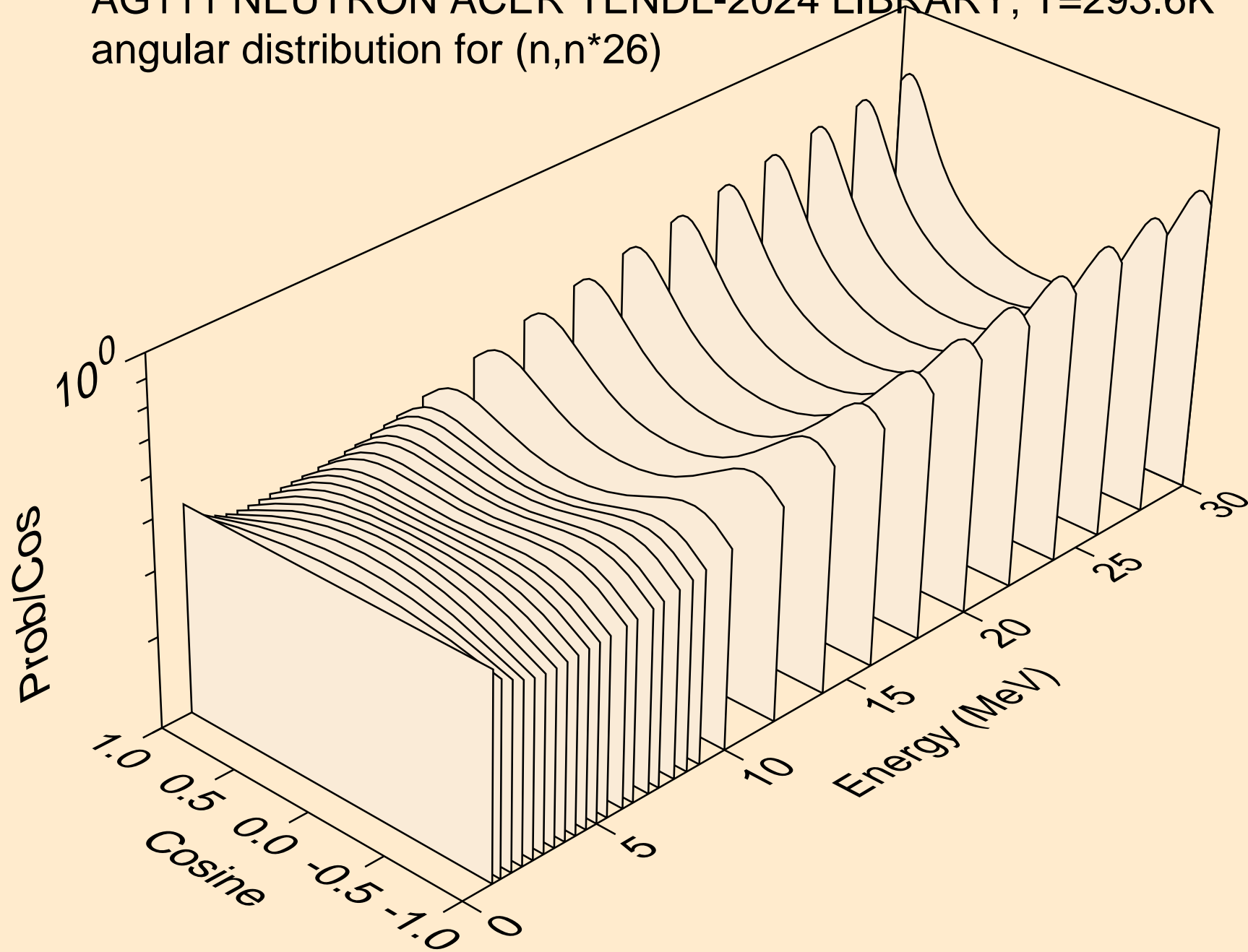

AG111 NEUTRON ACER TENDL-2024 LIBRARY; T=293.6K  
angular distribution for (n,n\*27)

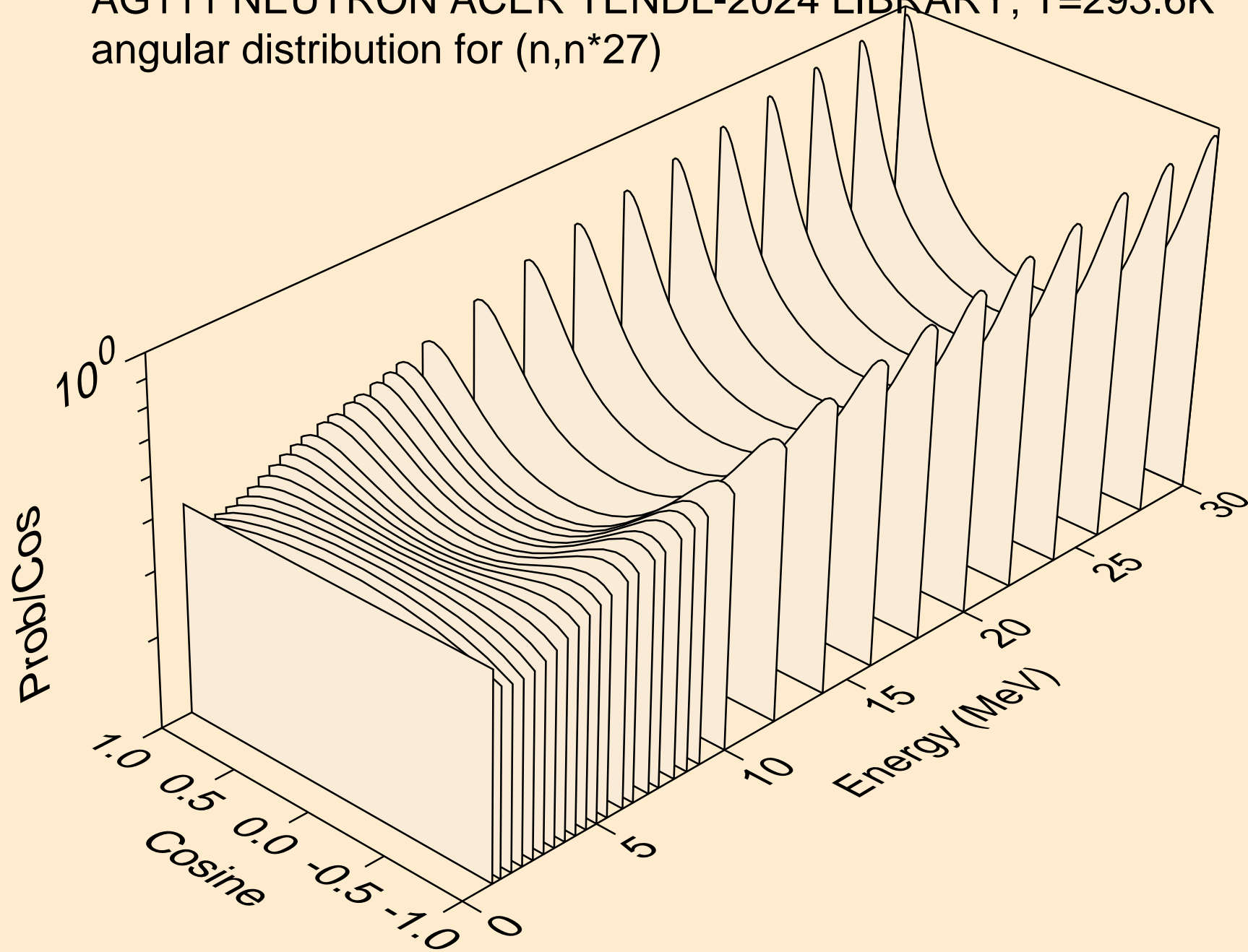

AG111 NEUTRON ACER TENDL-2024 LIBRARY; T=293.6K  
angular distribution for (n,n\*28)

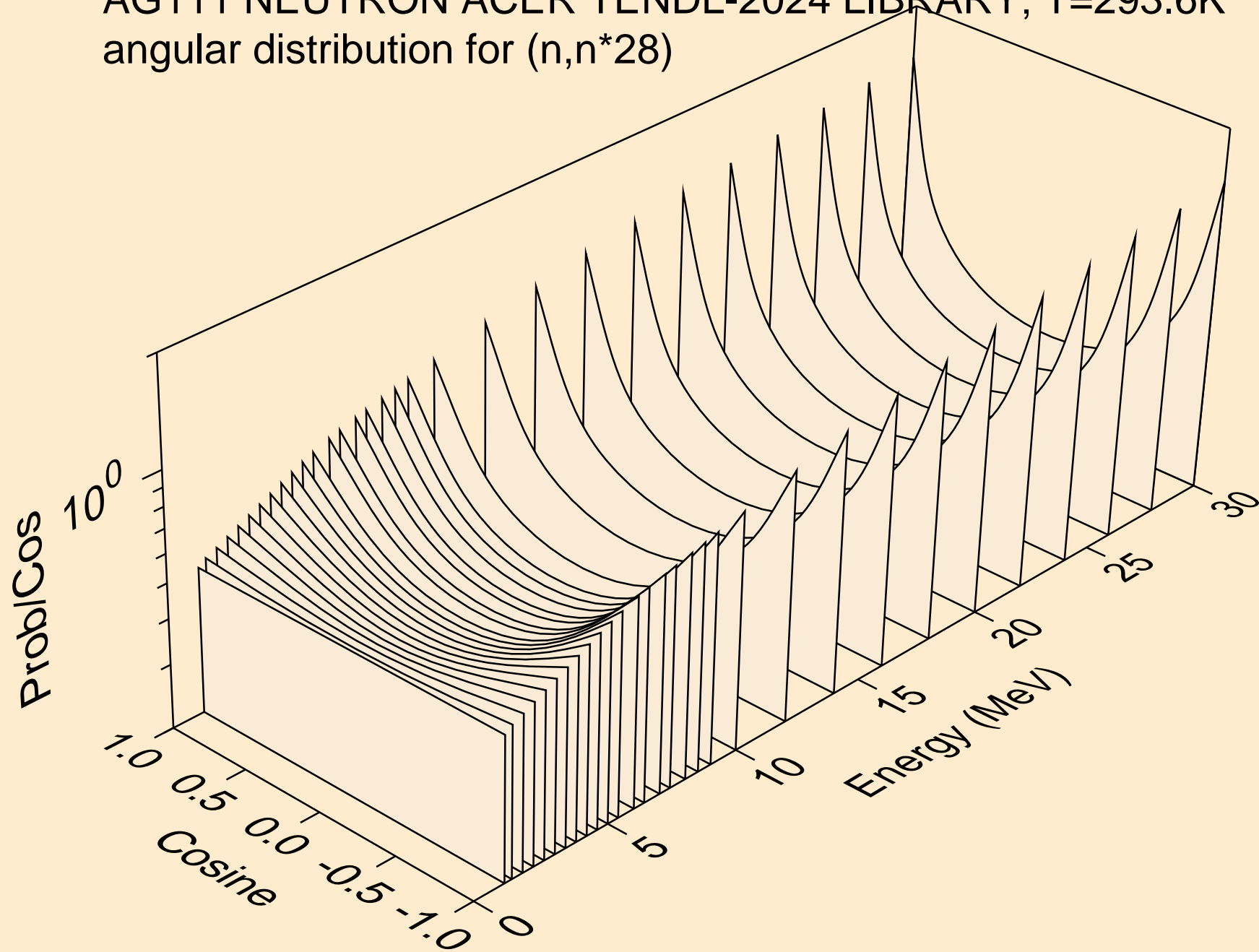

AG111 NEUTRON ACER TENDL-2024 LIBRARY; T=293.6K  
Neutron emission for (n,x)

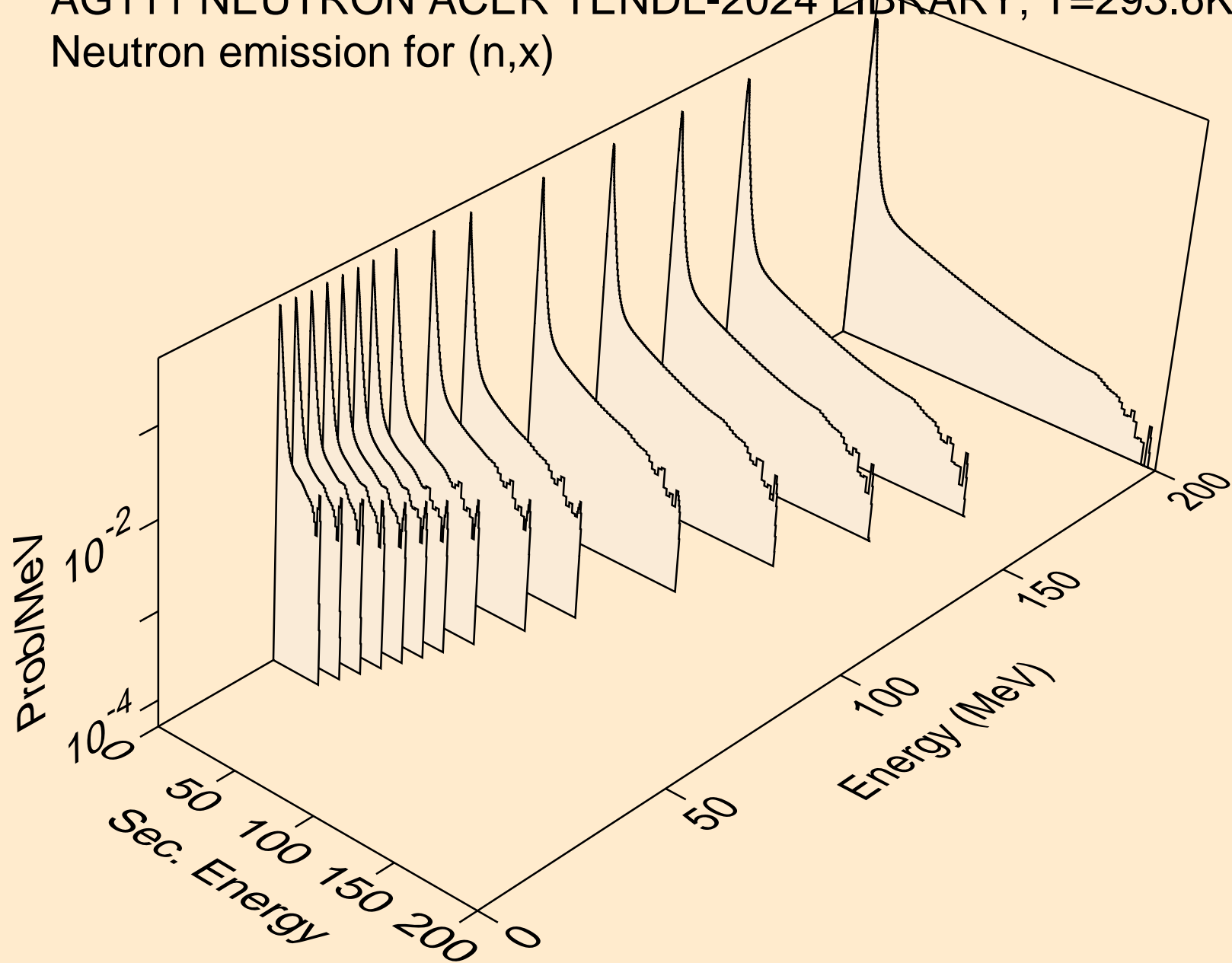

AG111 NEUTRON ACER TENDL-2024 LIBRARY; T=293.6K  
Neutron emission for (n,2nd)

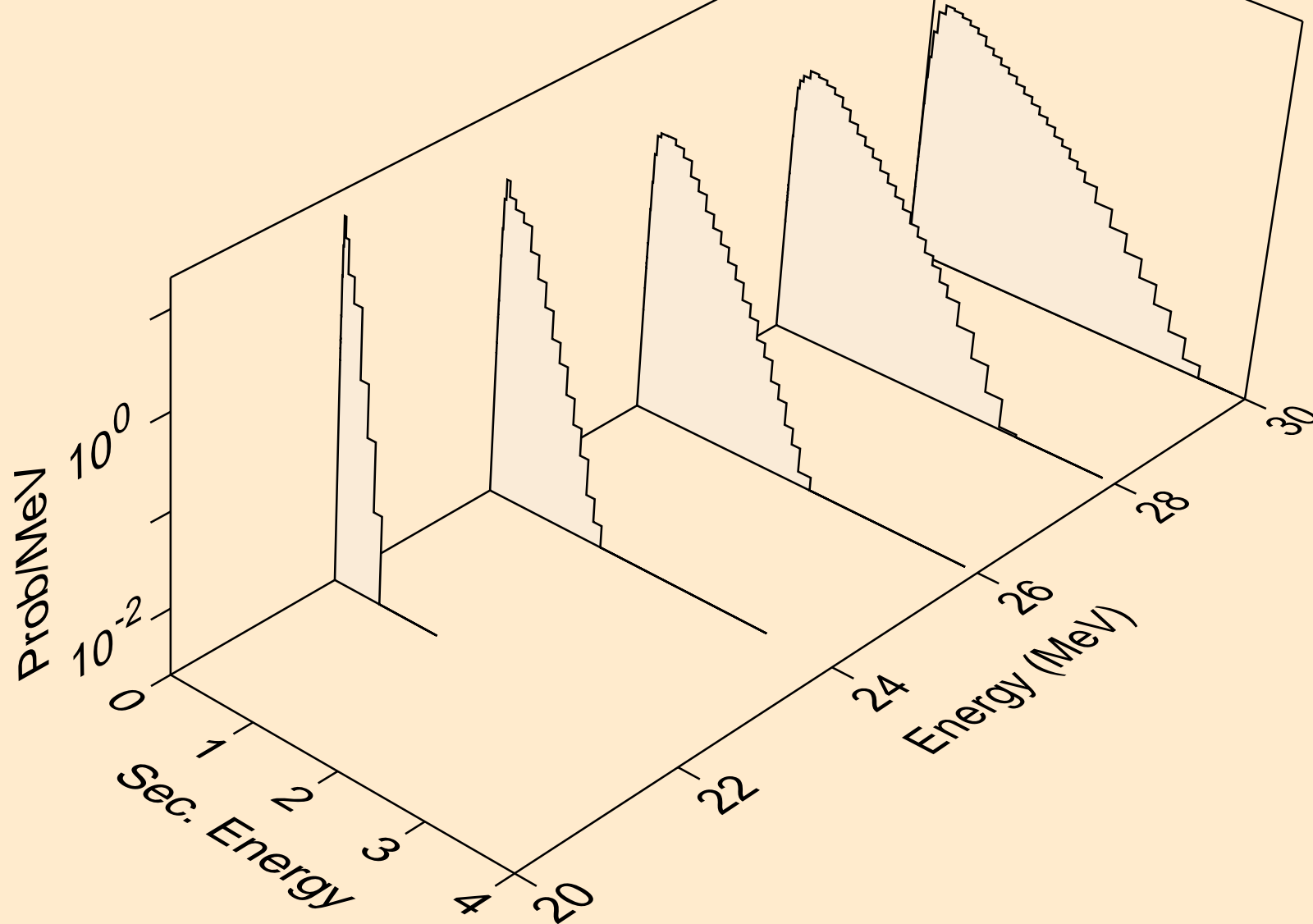

AG111 NEUTRON ACER TENDL-2024 LIBRARY; T=293.6K  
Neutron emission for (n,2n)

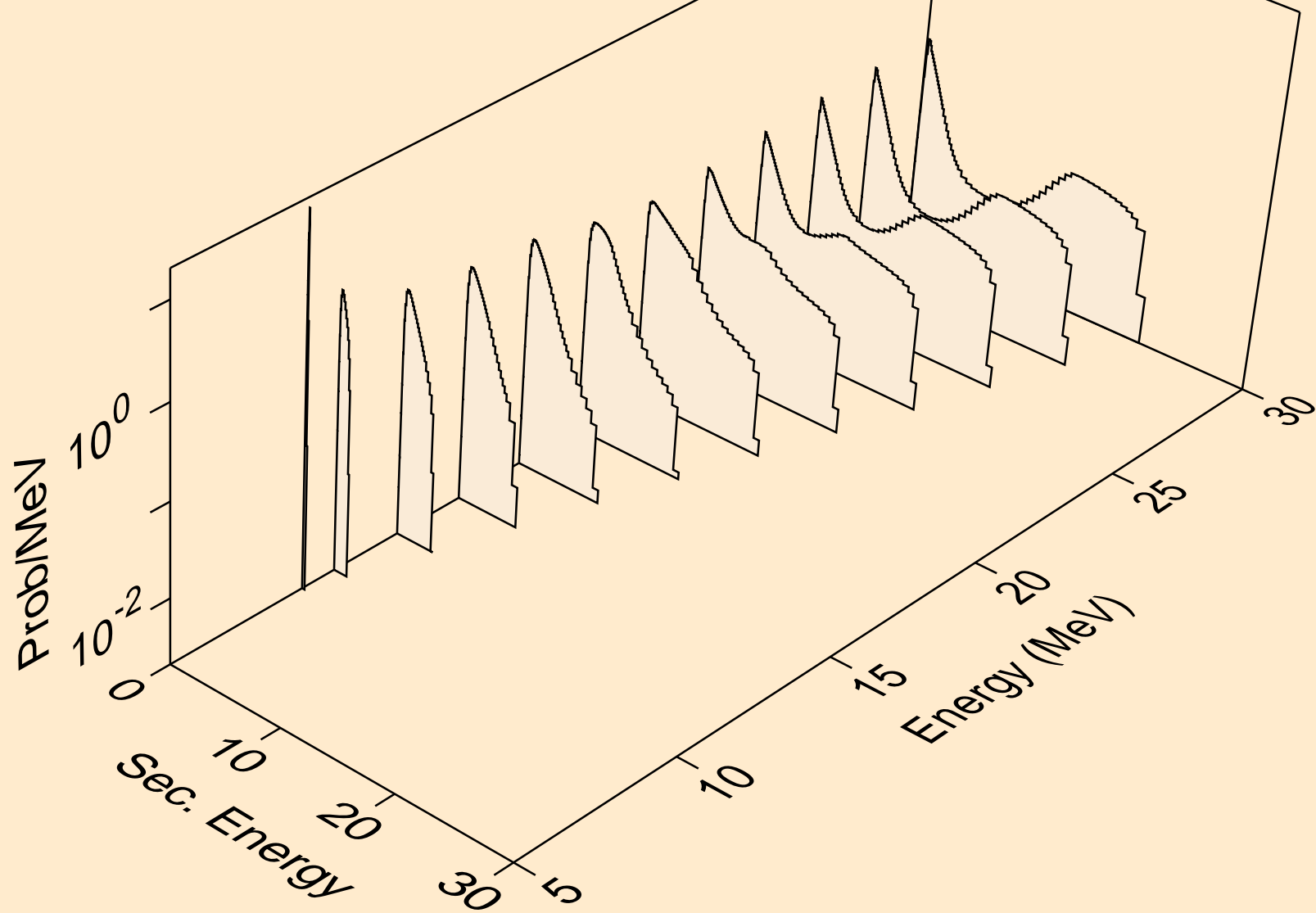

AG111 NEUTRON ACER TENDL-2024 LIBRARY; T=293.6K  
Neutron emission for (n,3n)

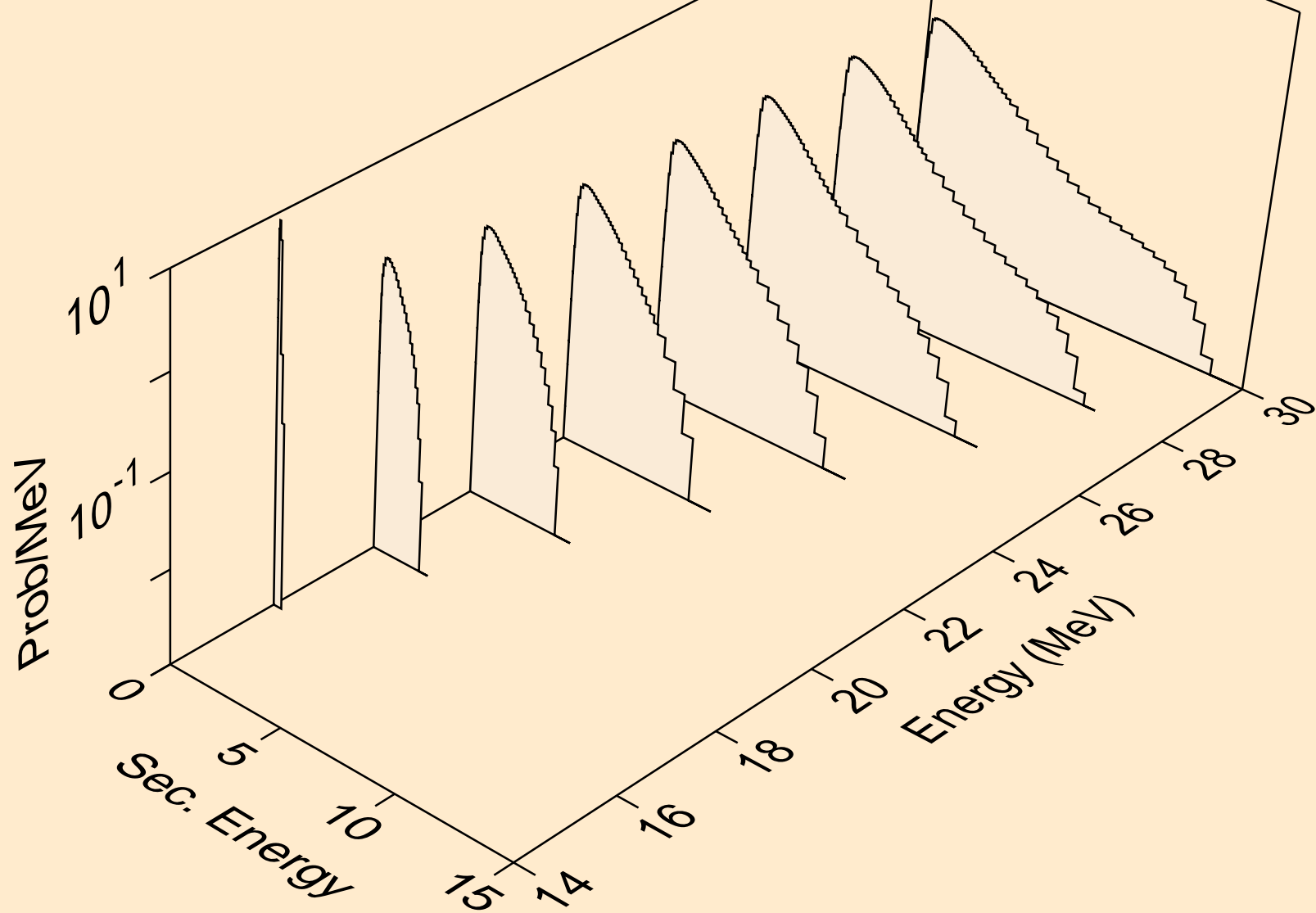

AG111 NEUTRON ACER TENDL-2024 LIBRARY; T=293.6K  
Neutron emission for (n,n\*)a

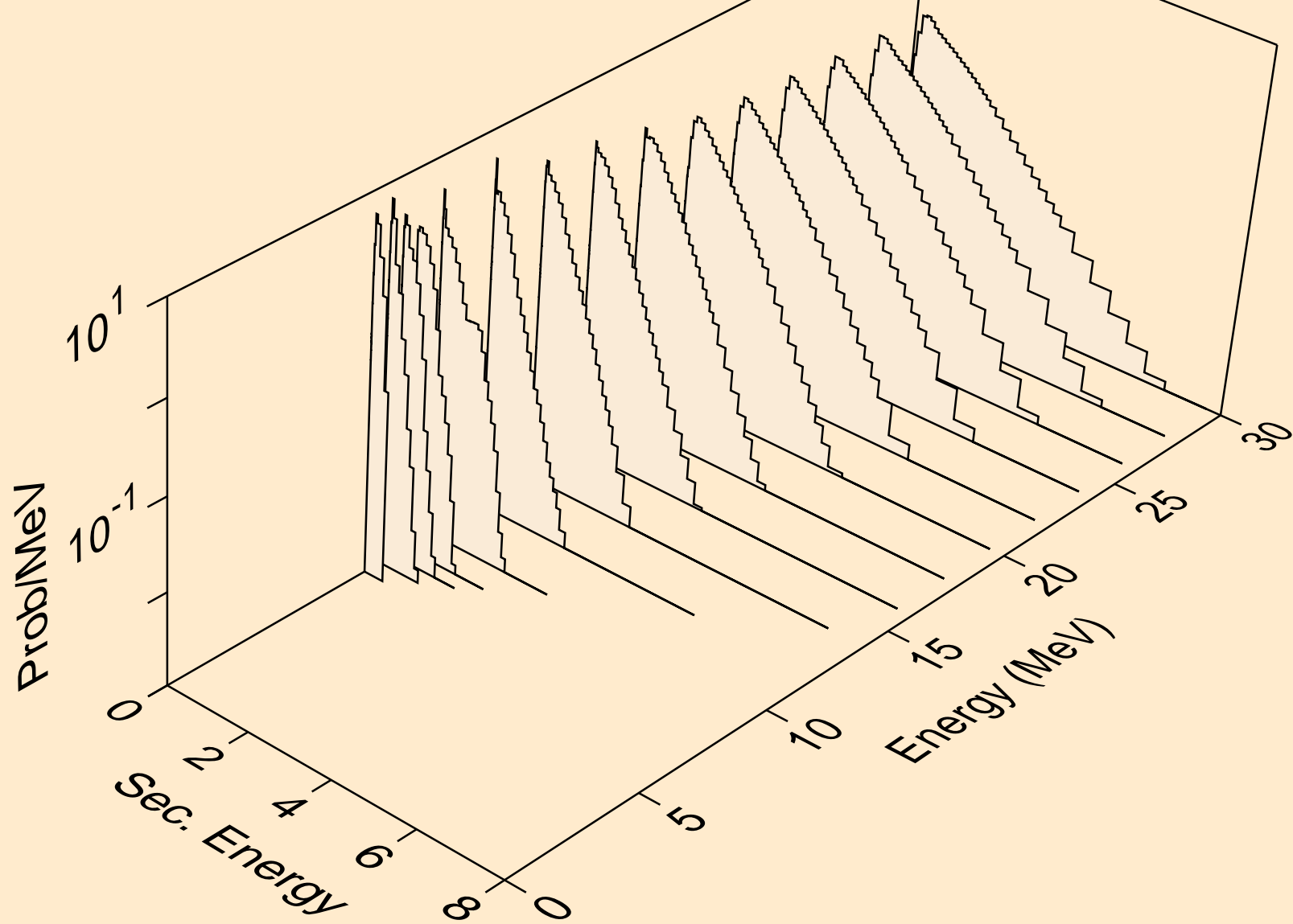

AG111 NEUTRON ACER TENDL-2024 LIBRARY; T=293.6K  
Neutron emission for (n,2n)<sub>a</sub>

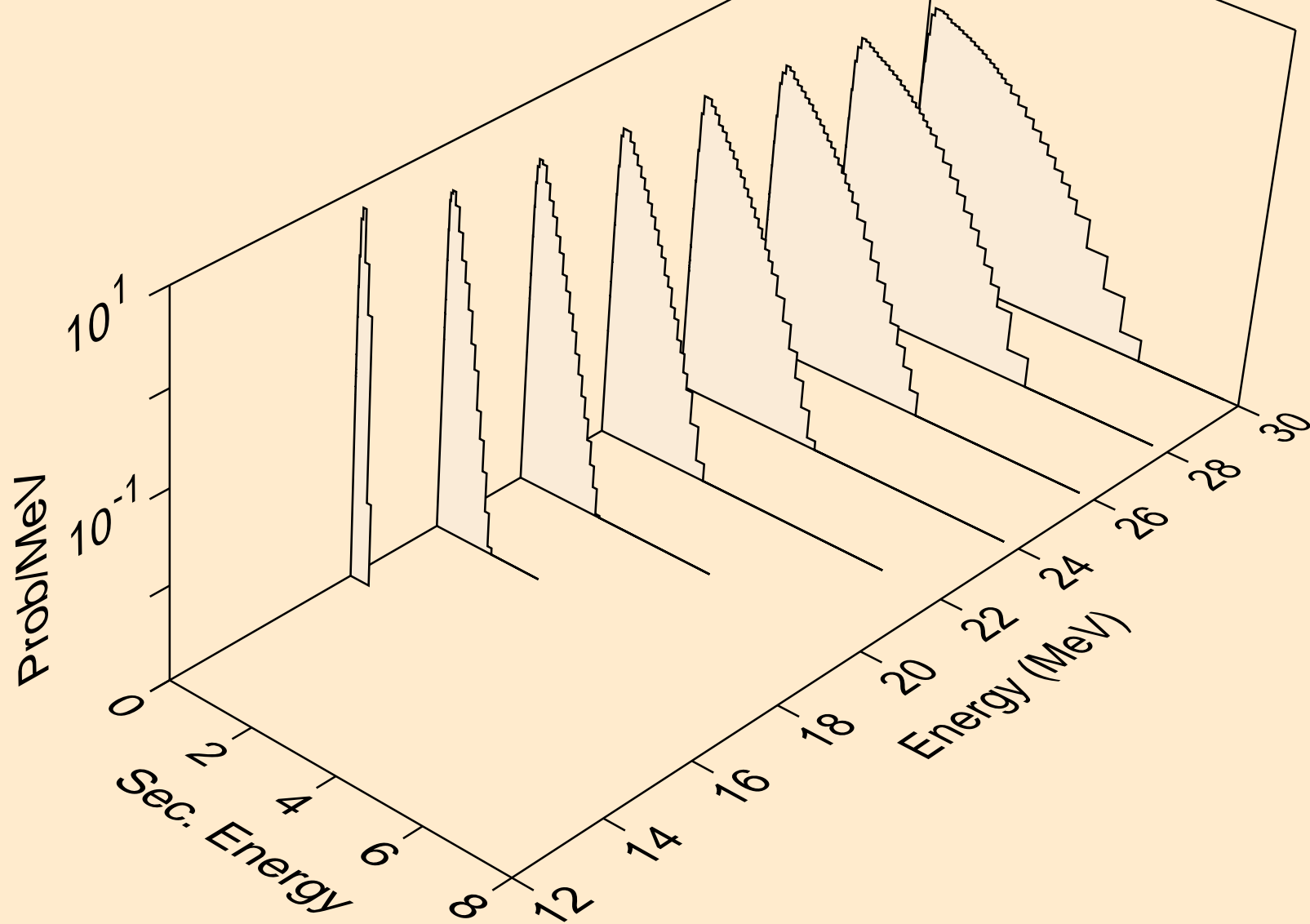

AG111 NEUTRON ACER TENDL-2024 LIBRARY; T=293.6K  
Neutron emission for (n,3n)a

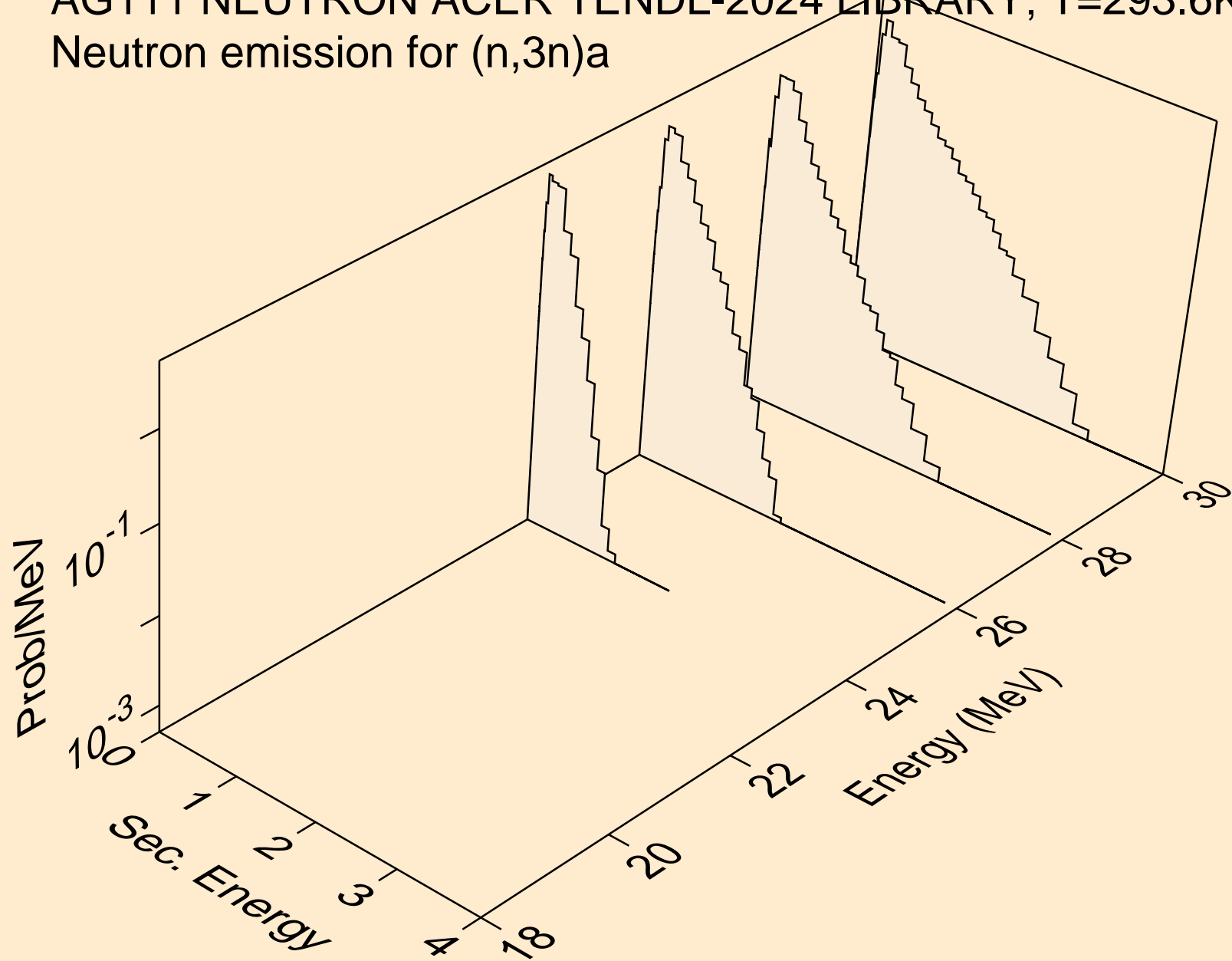

AG111 NEUTRON ACER TENDL-2024 LIBRARY; T=293.6K  
Neutron emission for (n,n\*)p

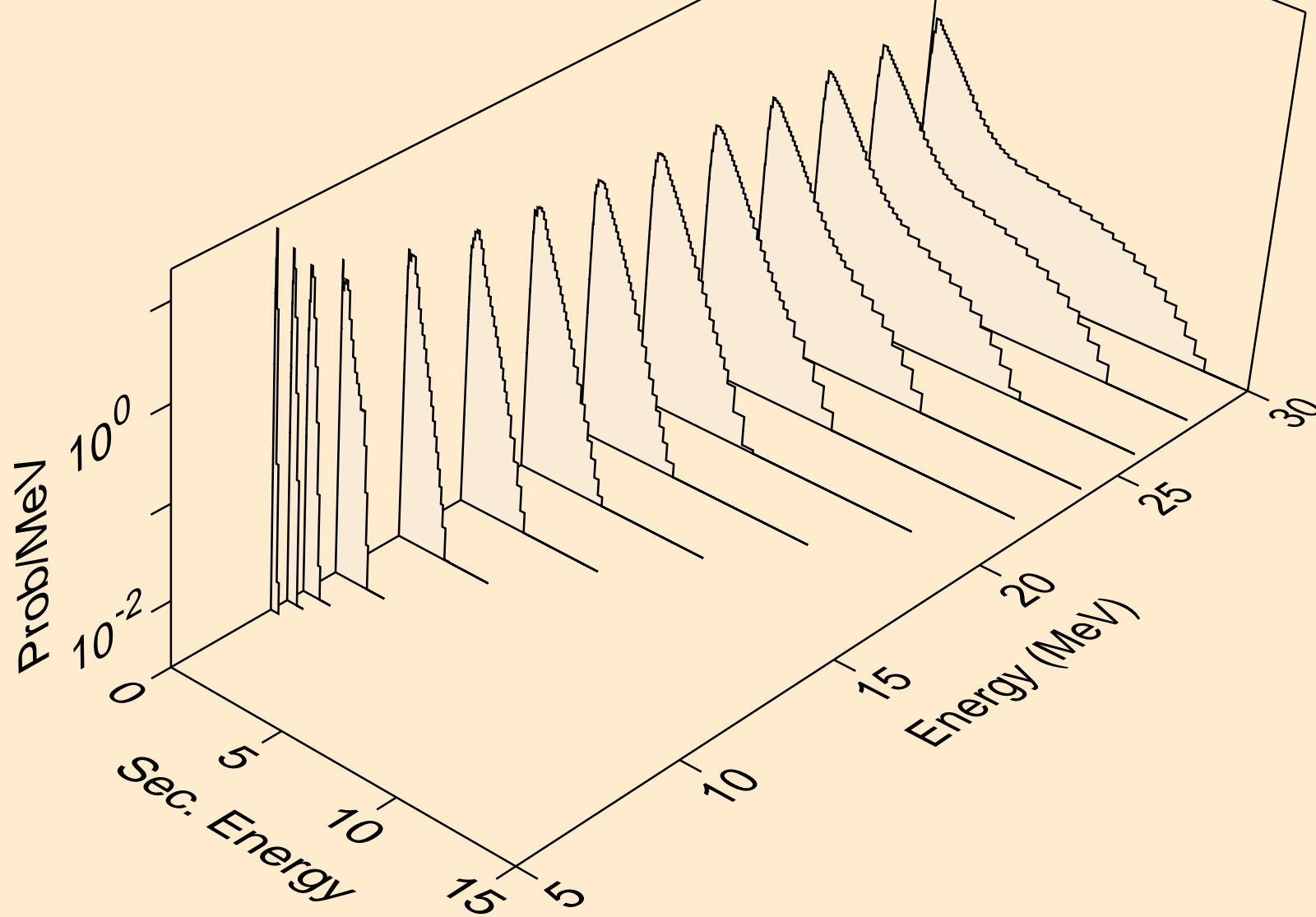

AG111 NEUTRON ACER TENDL-2024 LIBRARY; T=293.6K  
Neutron emission for (n,n\*)2a

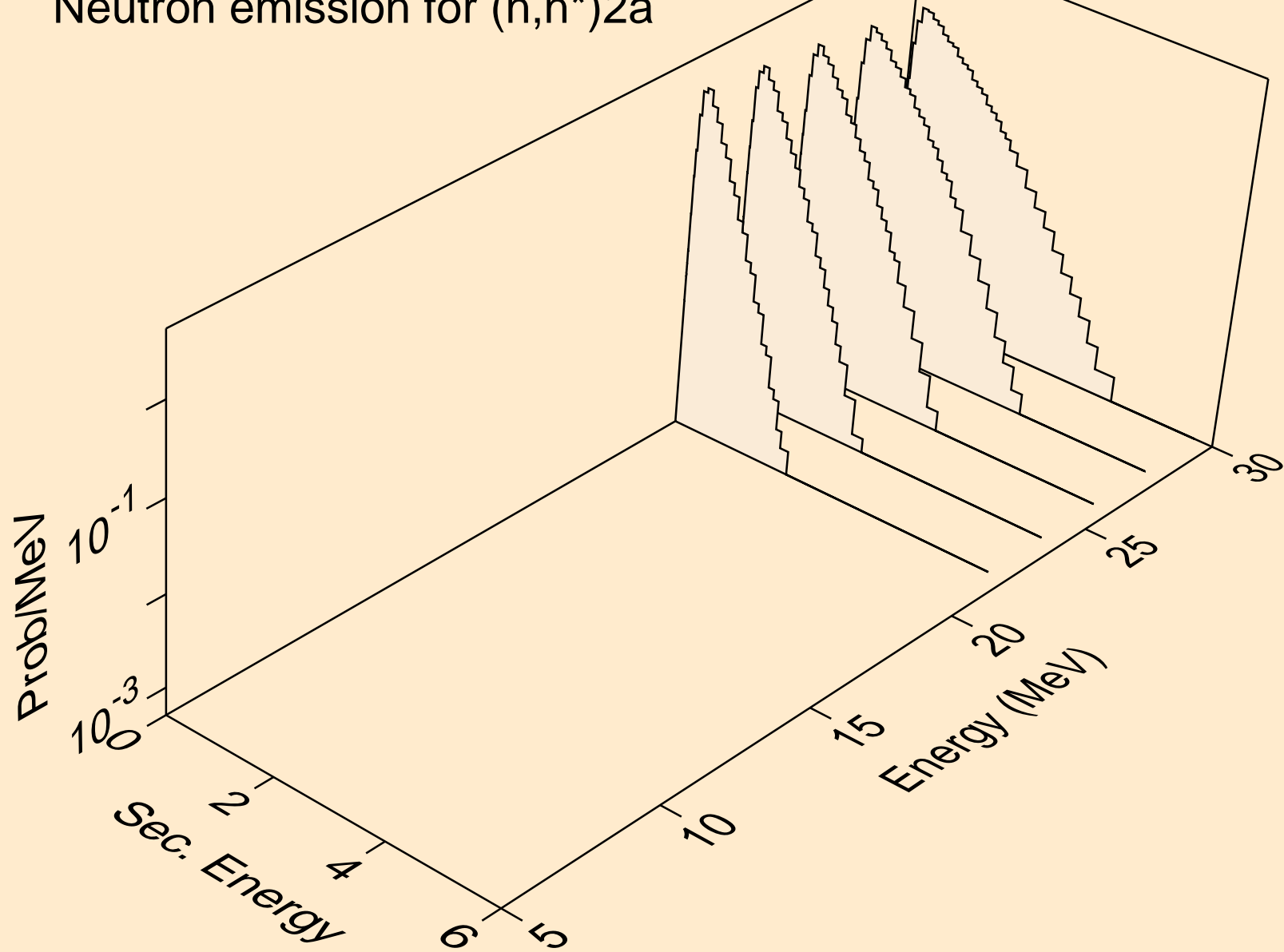

AG111 NEUTRON ACER TENDL-2024 LIBRARY; T=293.6K  
Neutron emission for (n,n\*)d

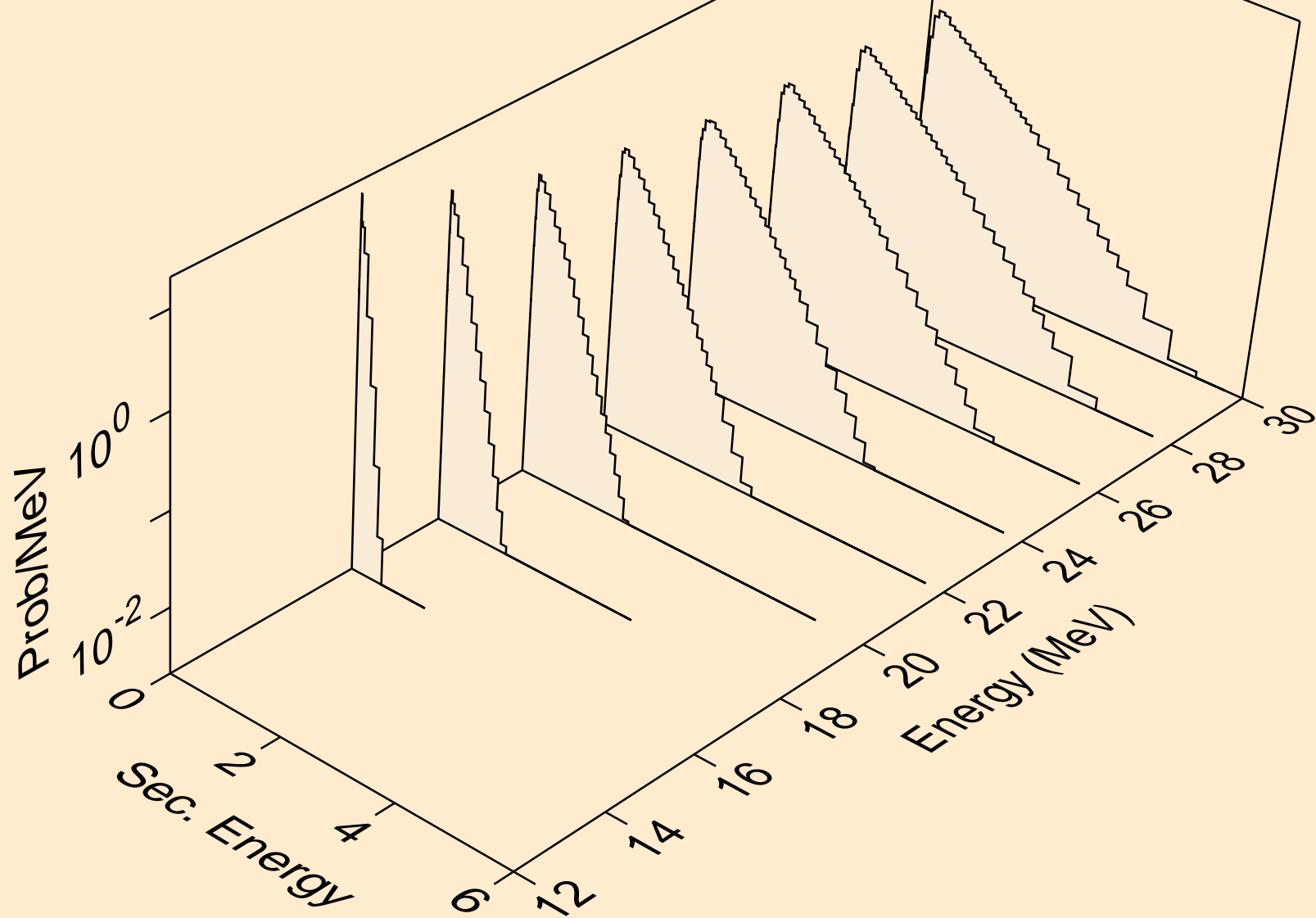

AG111 NEUTRON ACER TENDL-2024 LIBRARY; T=293.6K  
Neutron emission for (n,n\*)t

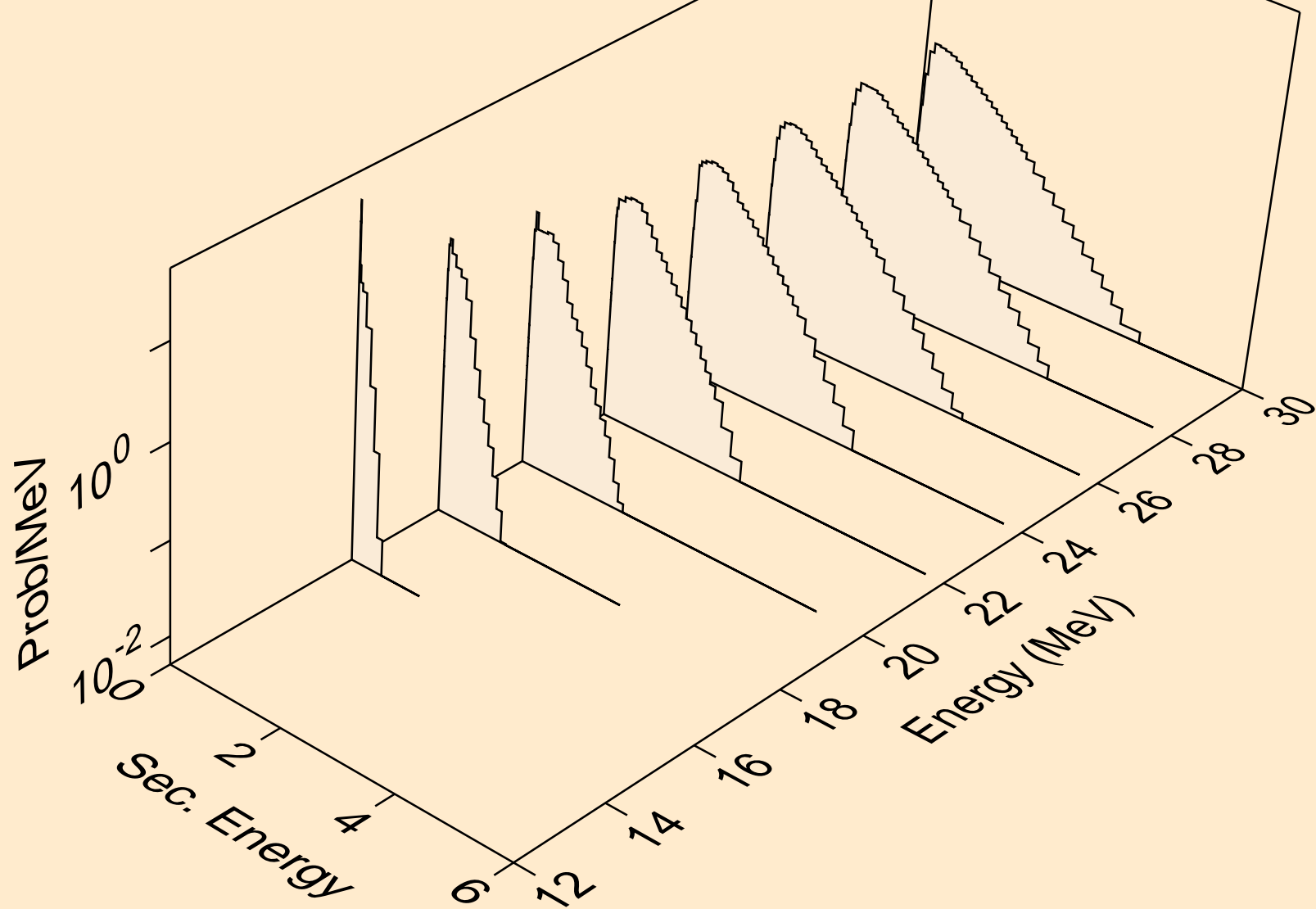

AG111 NEUTRON ACER TENDL-2024 LIBRARY; T=293.6K  
Neutron emission for (n,n\*)he3

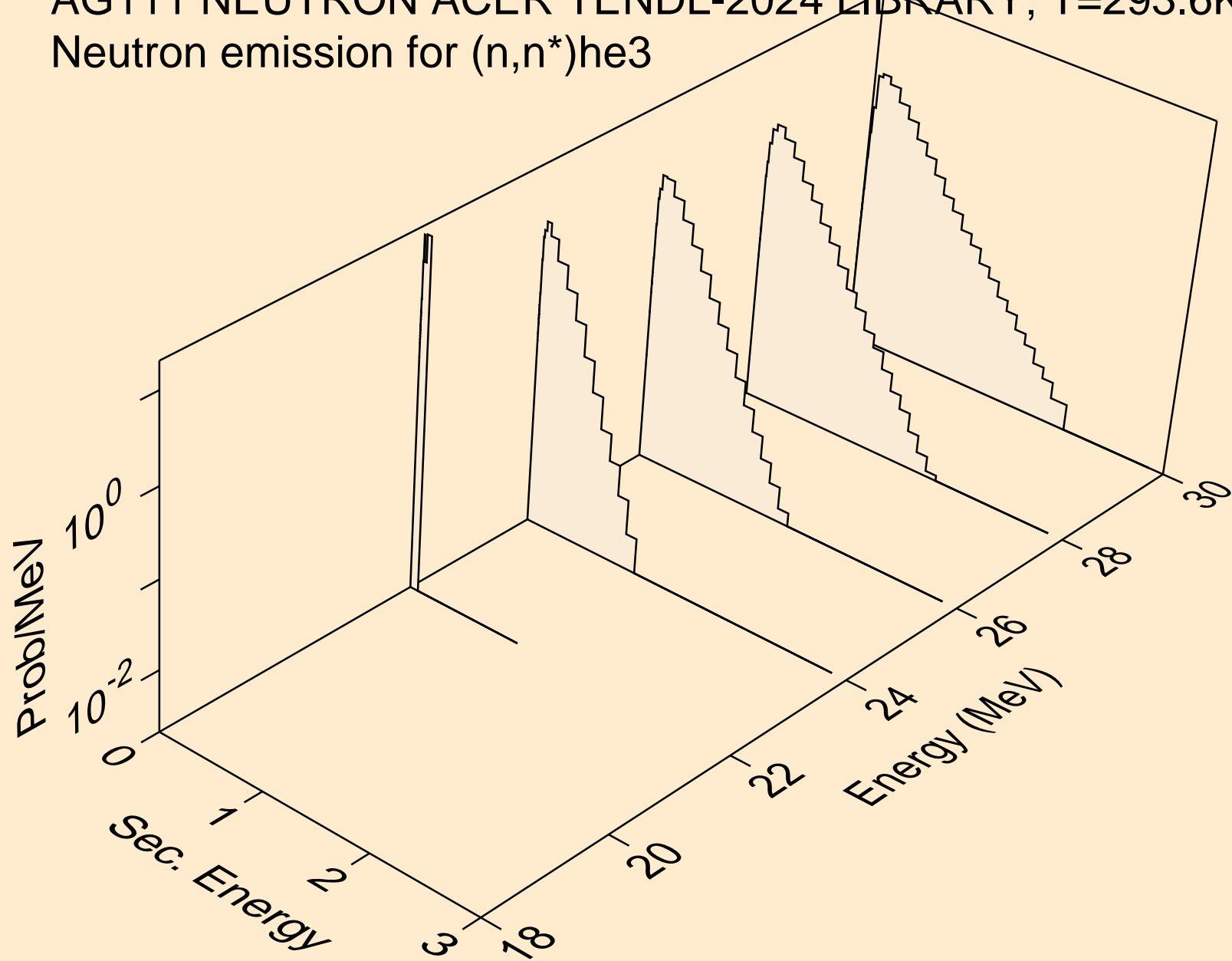

AG111 NEUTRON ACER TENDL-2024 LIBRARY; T=293.6K  
Neutron emission for (n,4n)

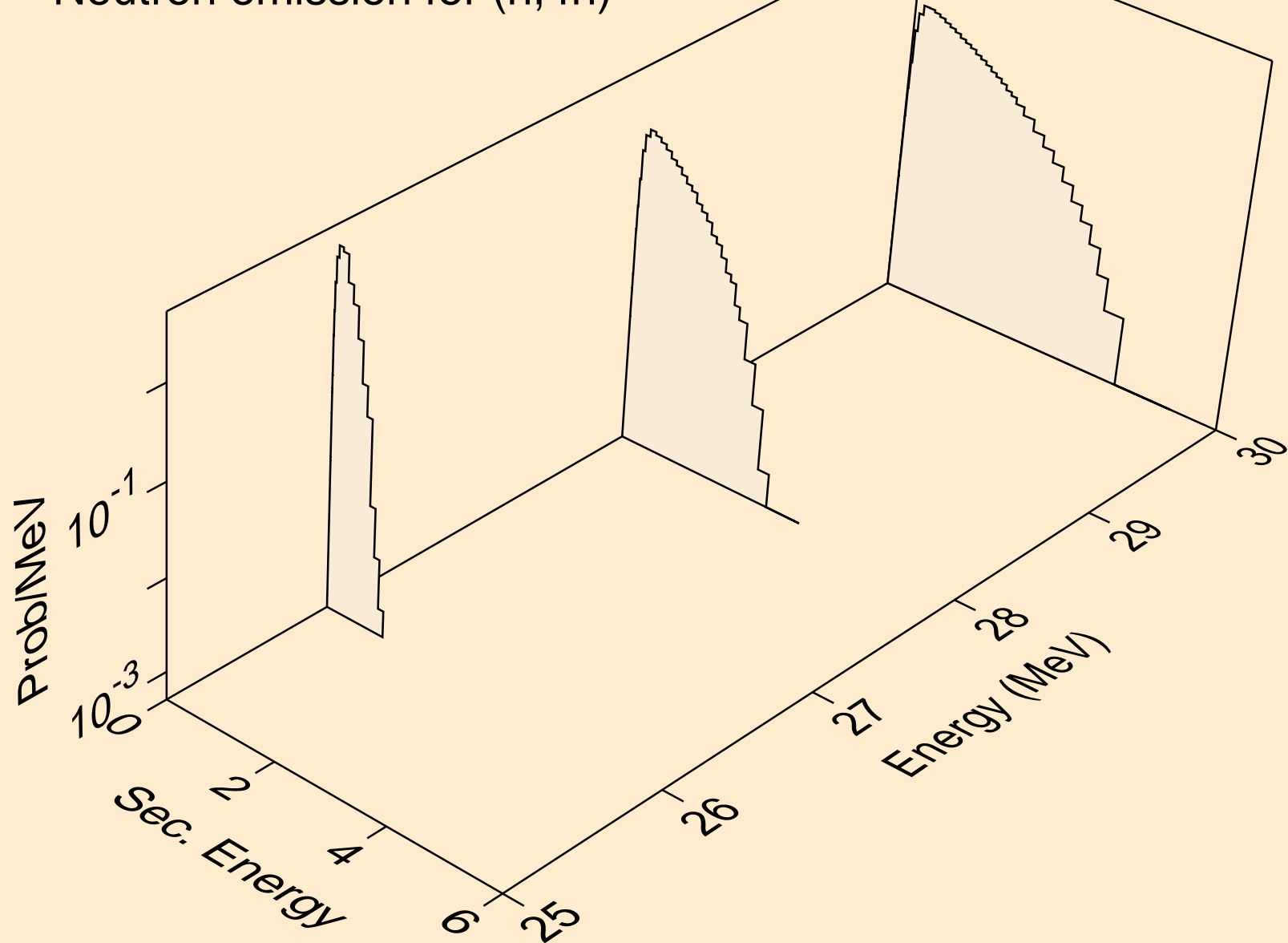

AG111 NEUTRON ACER TENDL-2024 LIBRARY; T=293.6K  
Neutron emission for (n,2np)

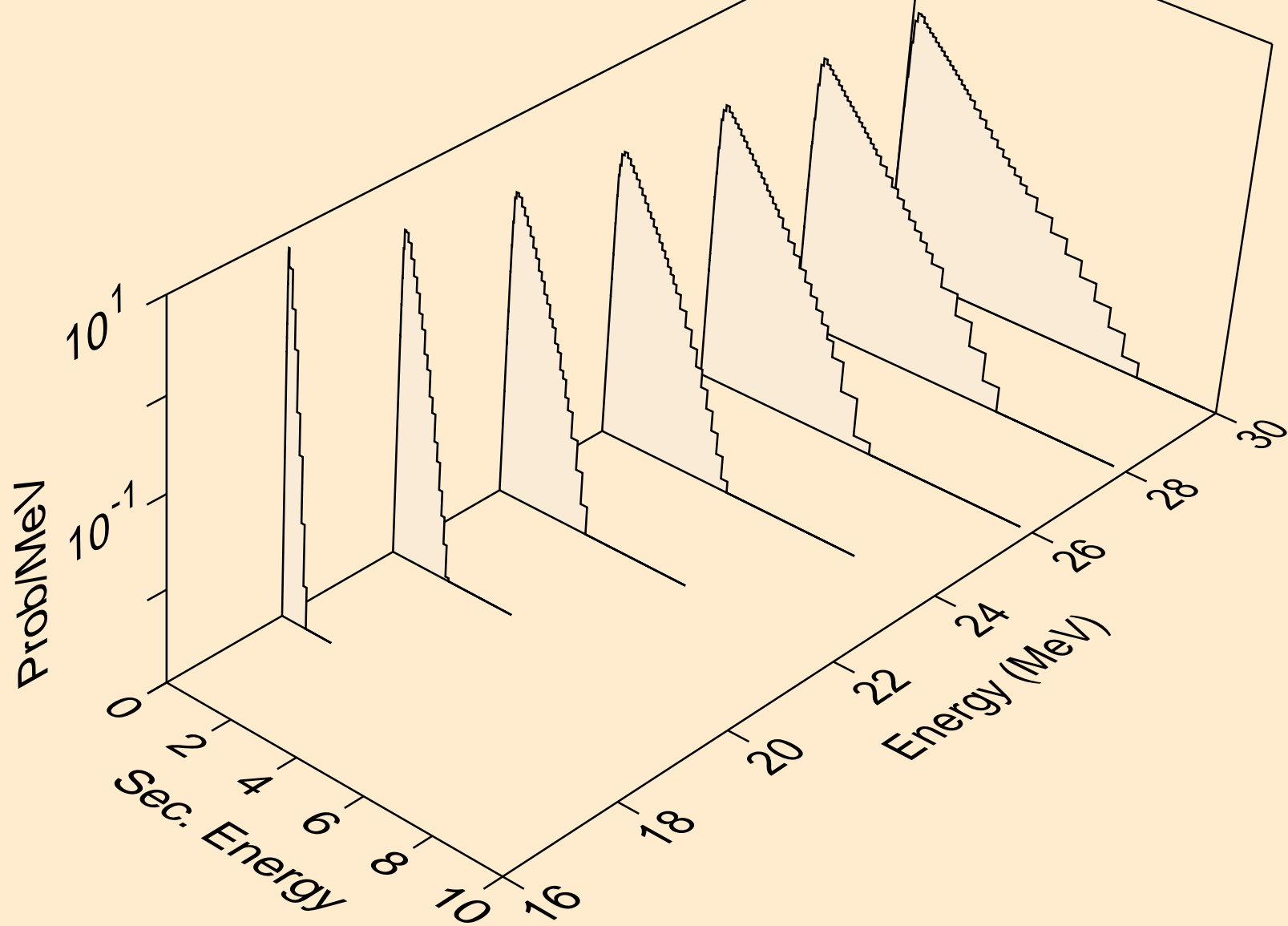

AG111 NEUTRON ACER TENDL-2024 LIBRARY; T=293.6K  
Neutron emission for (n,3np)

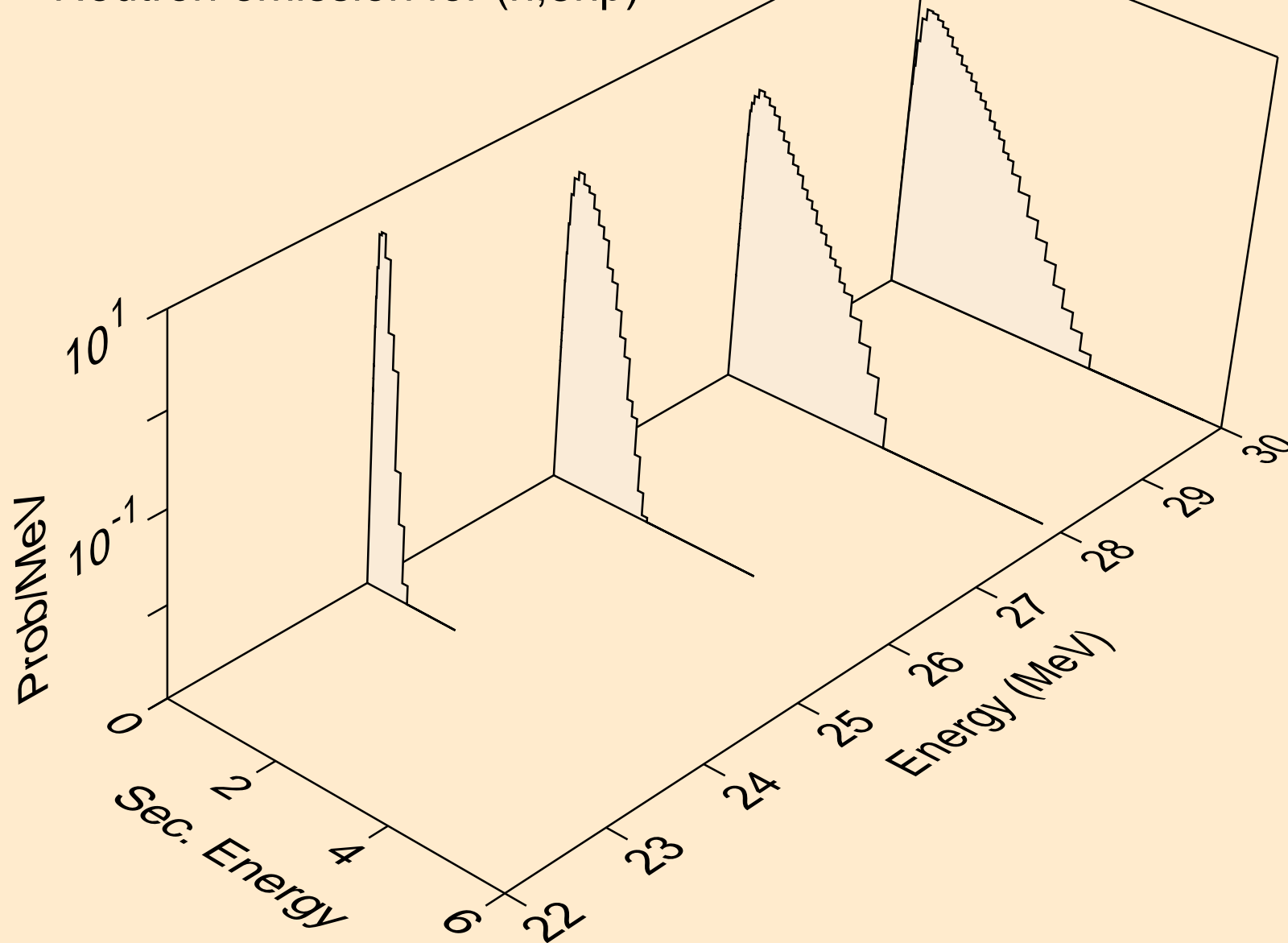

AG111 NEUTRON ACER TENDL-2024 LIBRARY; T=293.6K  
Neutron emission for (n,n2p)

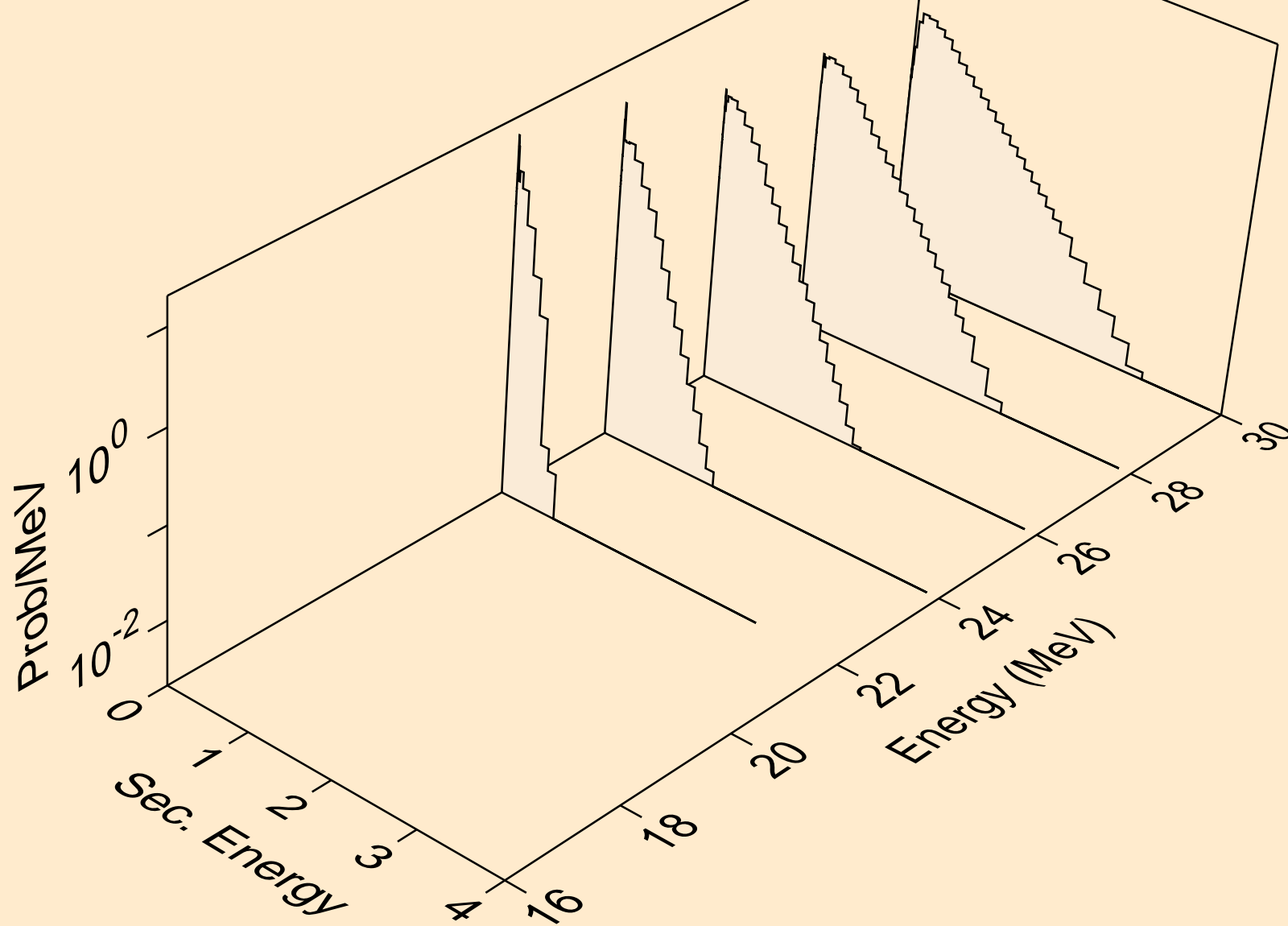

AG111 NEUTRON ACER TENDL-2024 LIBRARY; T=293.6K  
Neutron emission for (n,npa)

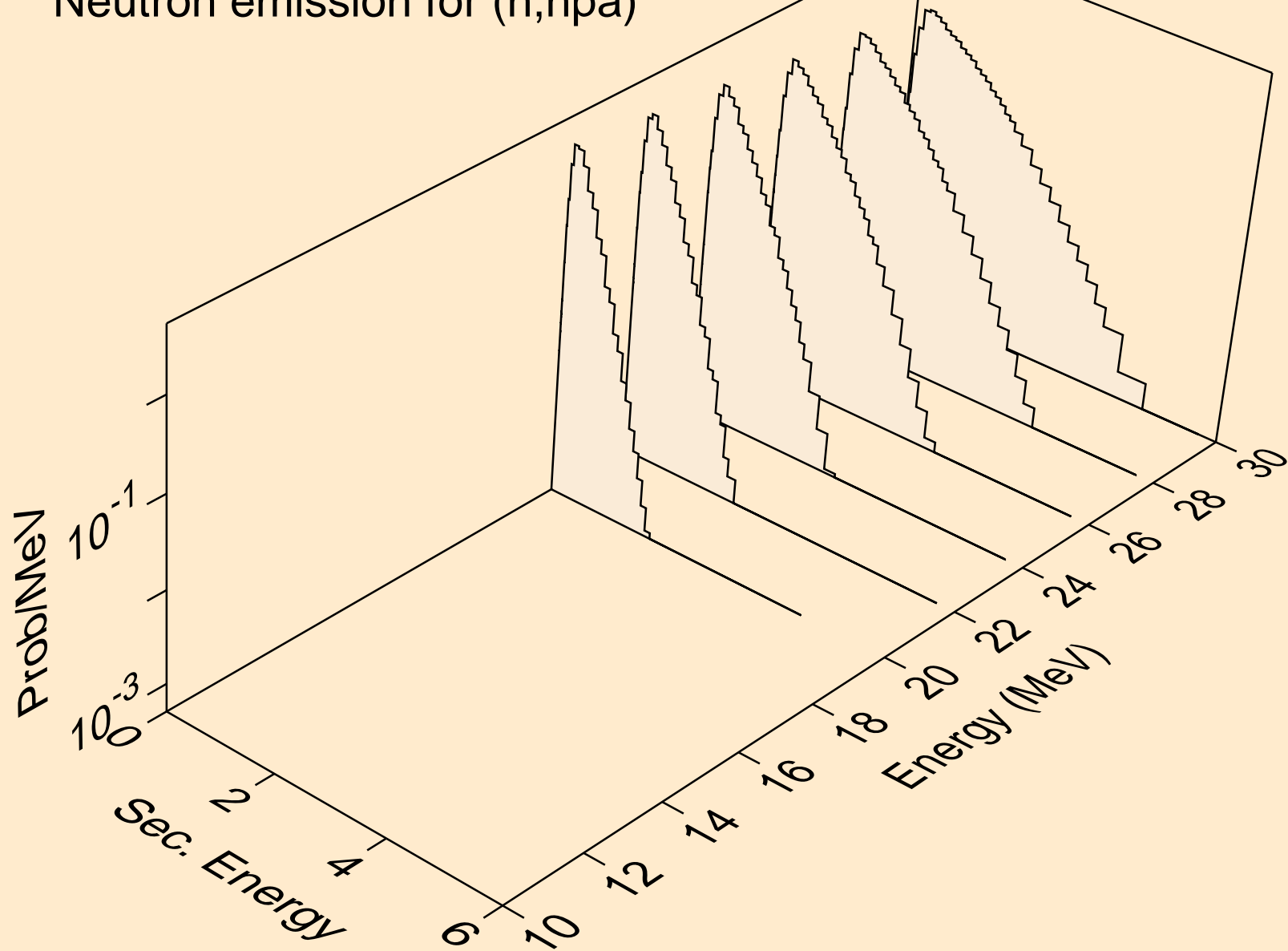

AG111 NEUTRON ACER TENDL-2024 LIBRARY; T=293.6K  
Neutron emission for (n,n\*c)

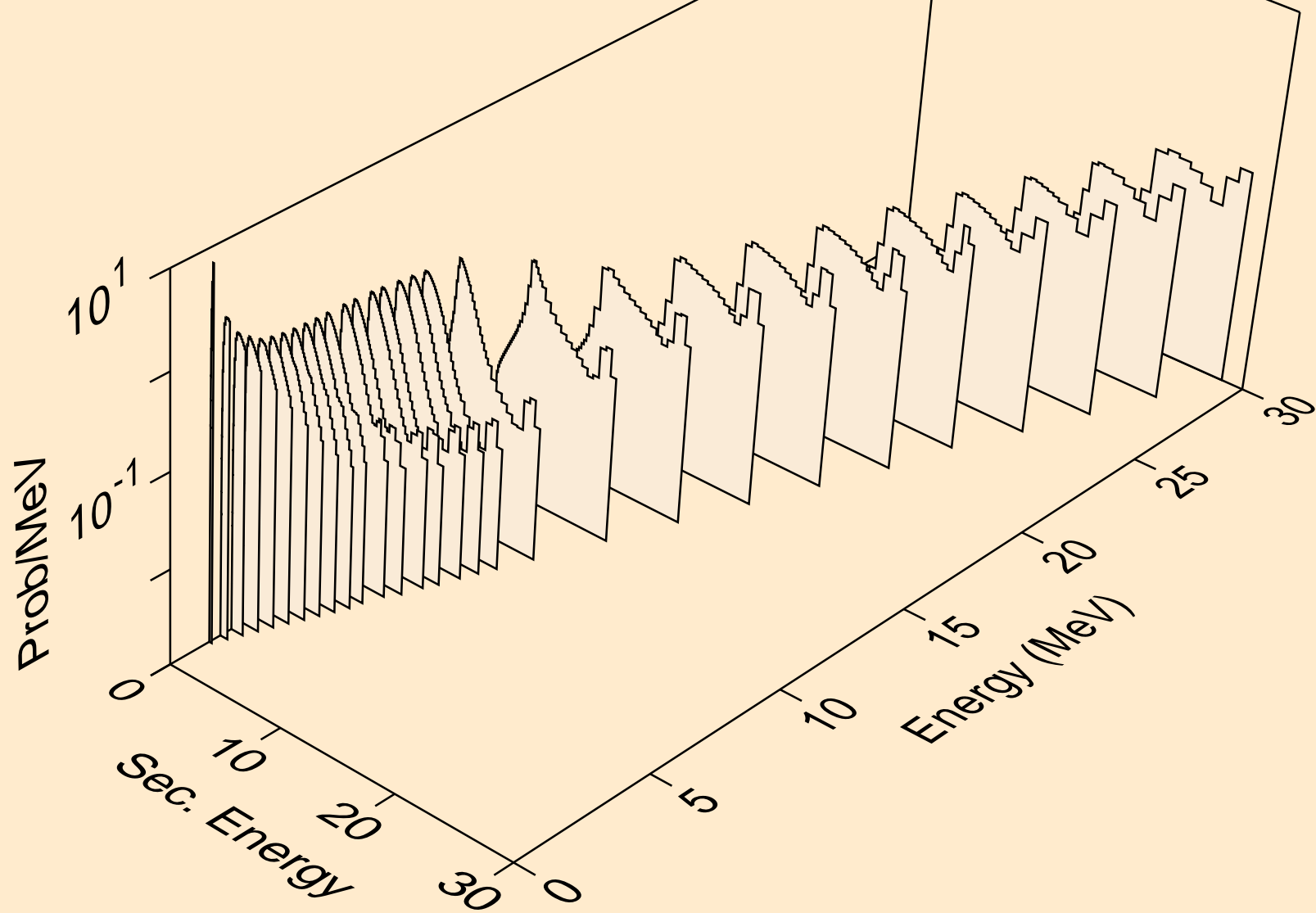

AG111 NEUTRON ACER TENDL-2024 LIBRARY; T=293.6K  
Photon emission for (n,x)

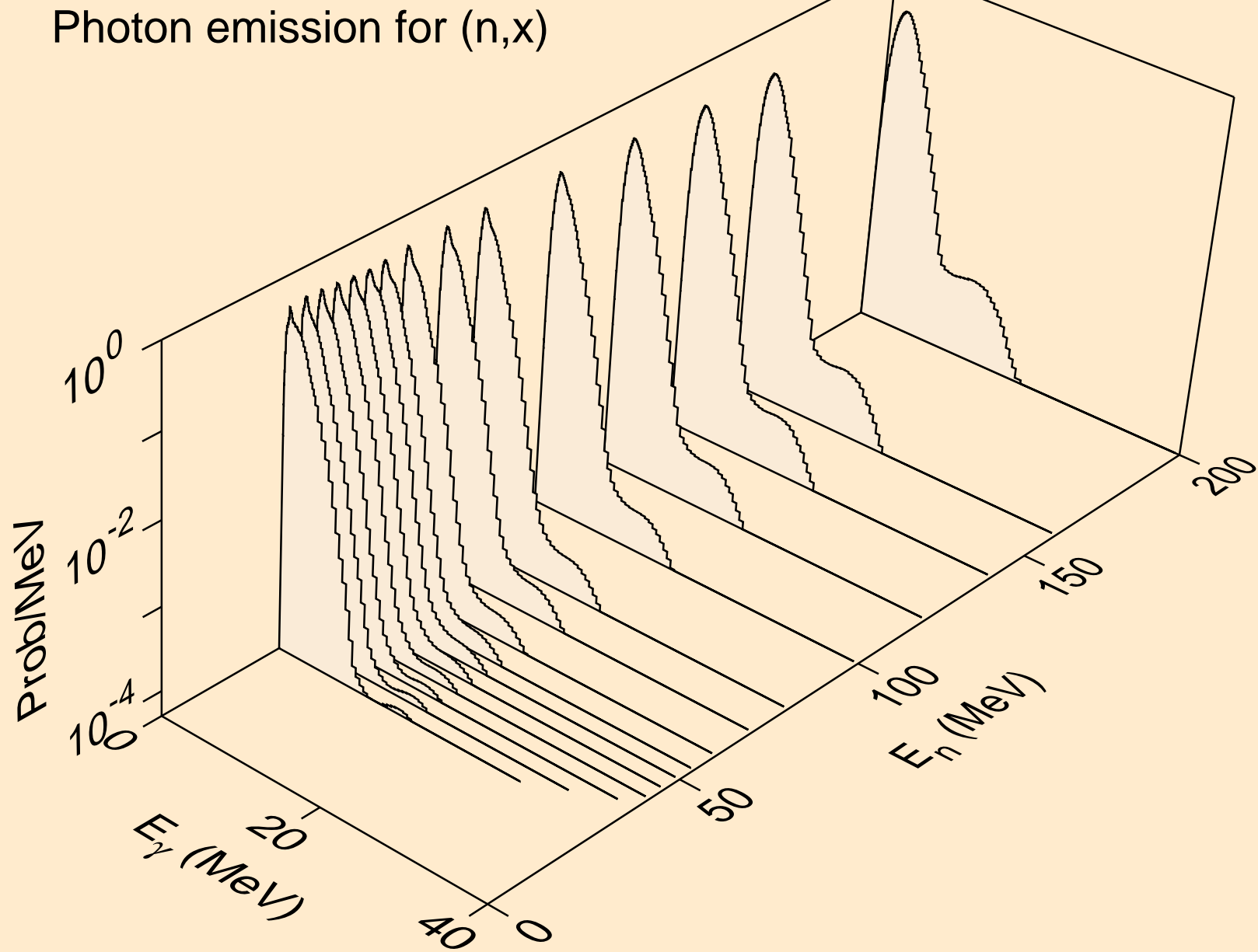

AG111 NEUTRON ACER TENDL-2024 LIBRARY; T=293.6K  
Photon emission for (n,2nd)

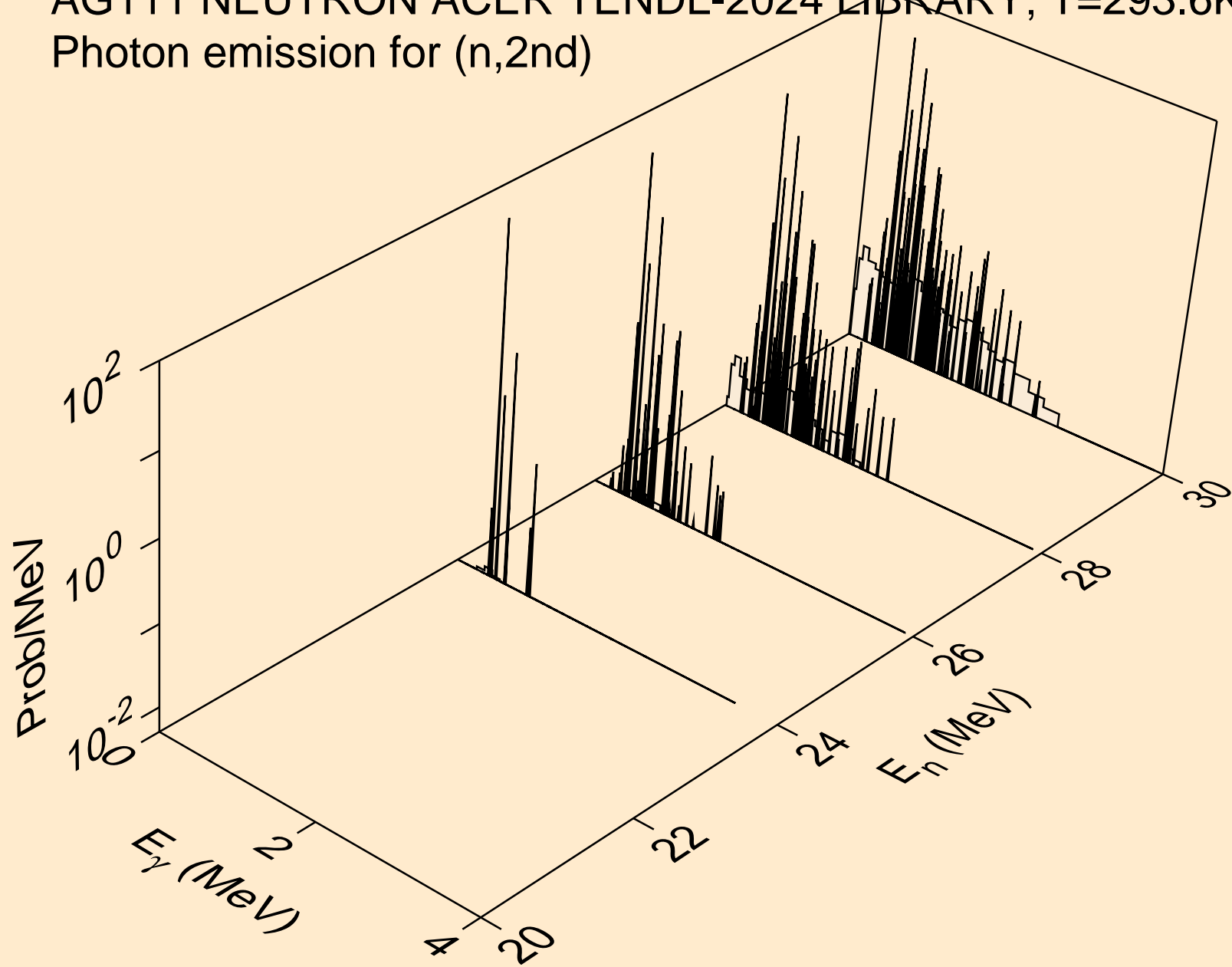

AG111 NEUTRON ACER TENDL-2024 LIBRARY; T=293.6K  
Photon emission for (n,2n)

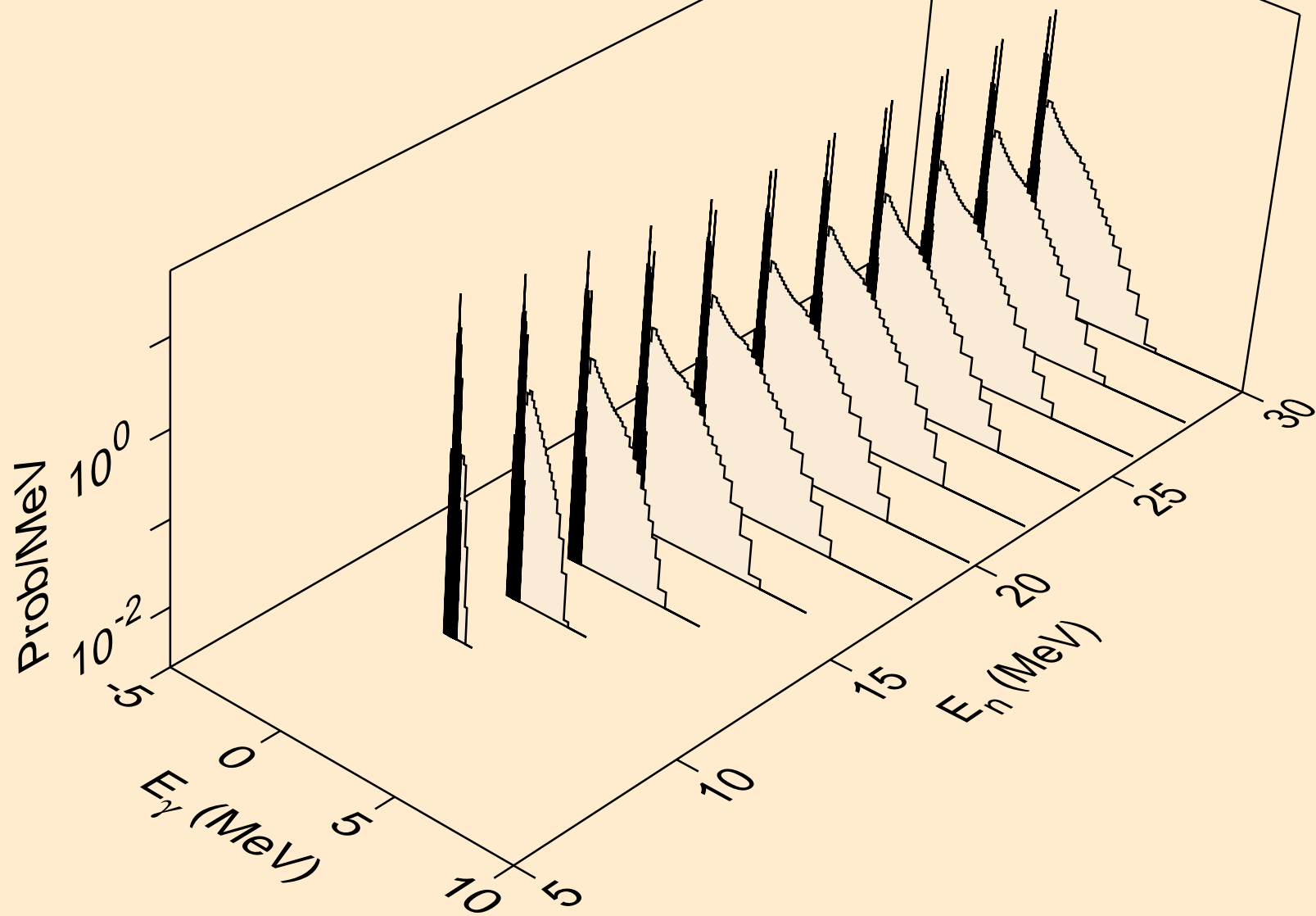

AG111 NEUTRON ACER TENDL-2024 LIBRARY; T=293.6K  
Photon emission for (n,3n)

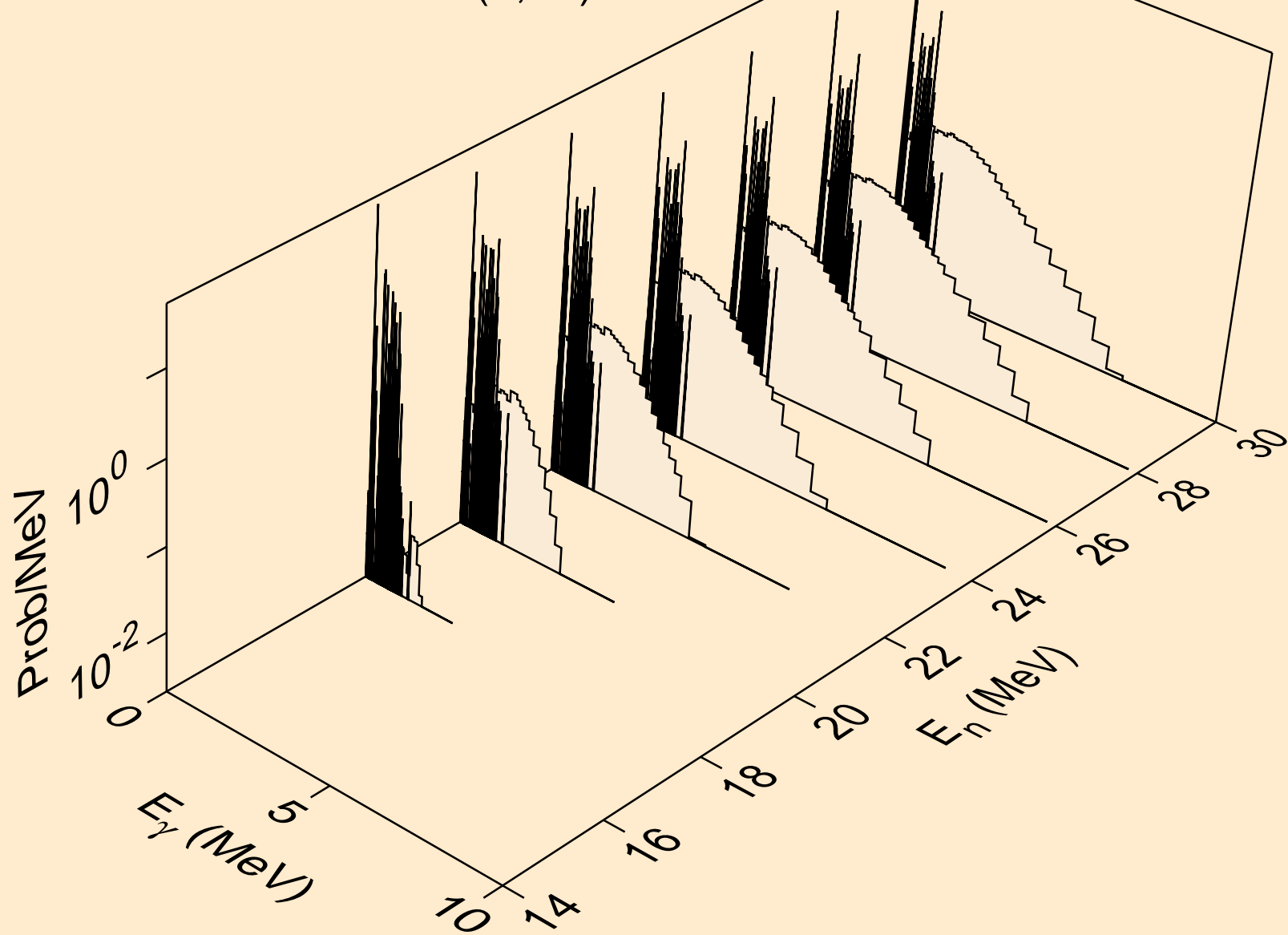

AG111 NEUTRON ACER TENDL-2024 LIBRARY; T=293.6K  
Photon emission for (n,n\*)a

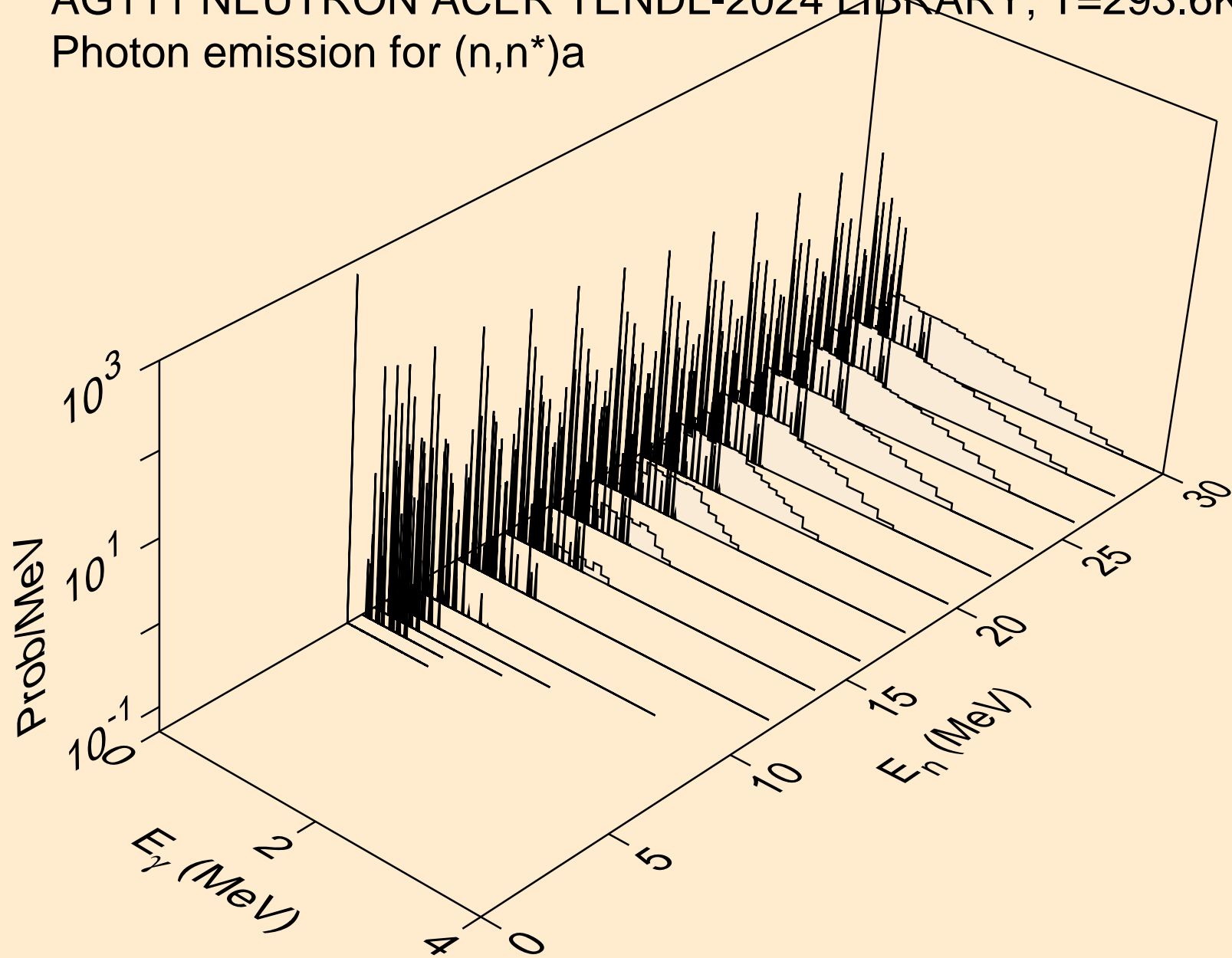

AG111 NEUTRON ACER TENDL-2024 LIBRARY; T=293.6K  
Photon emission for (n,2n)a

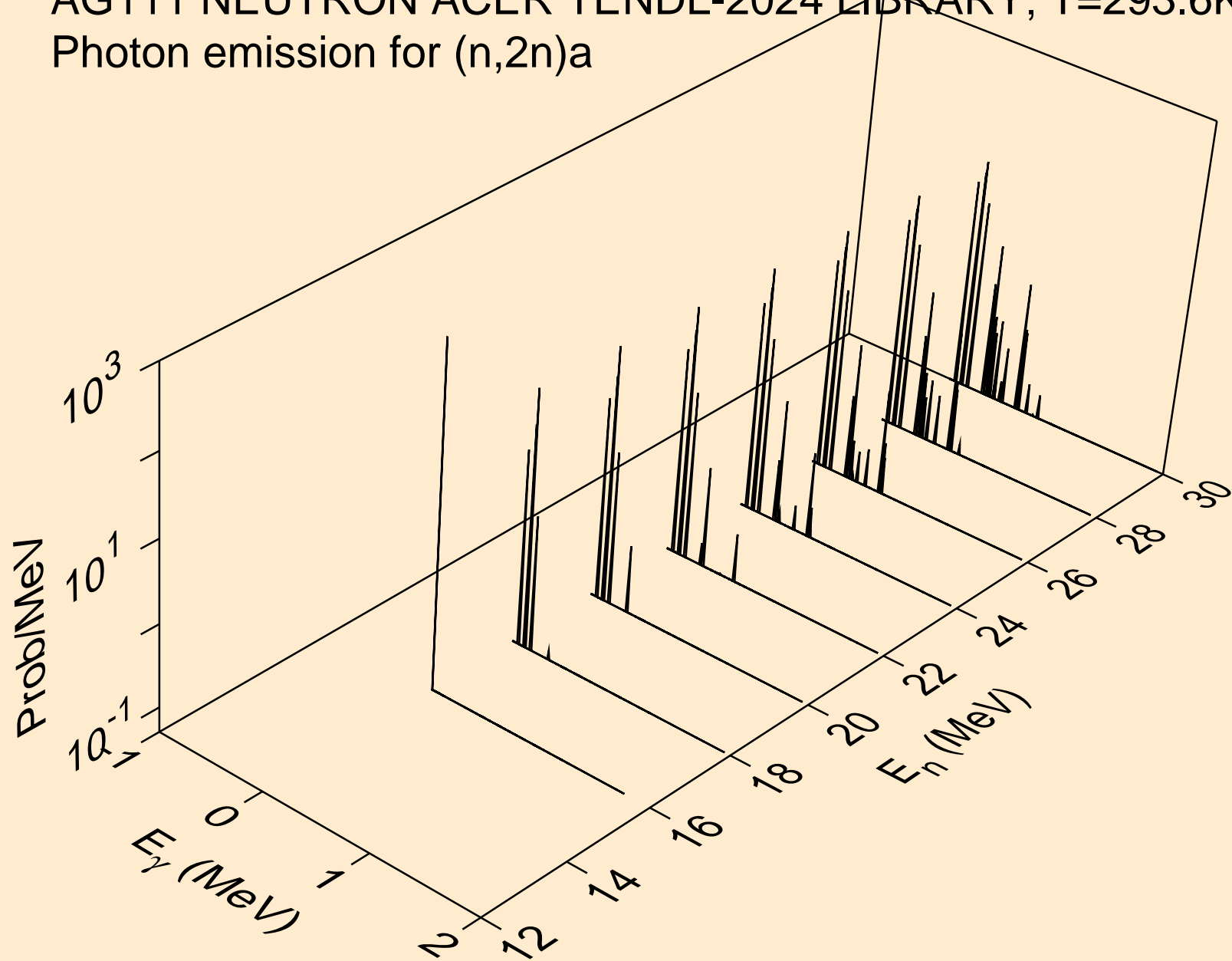

AG111 NEUTRON ACER TENDL-2024 LIBRARY; T=293.6K  
Photon emission for (n,3n)a

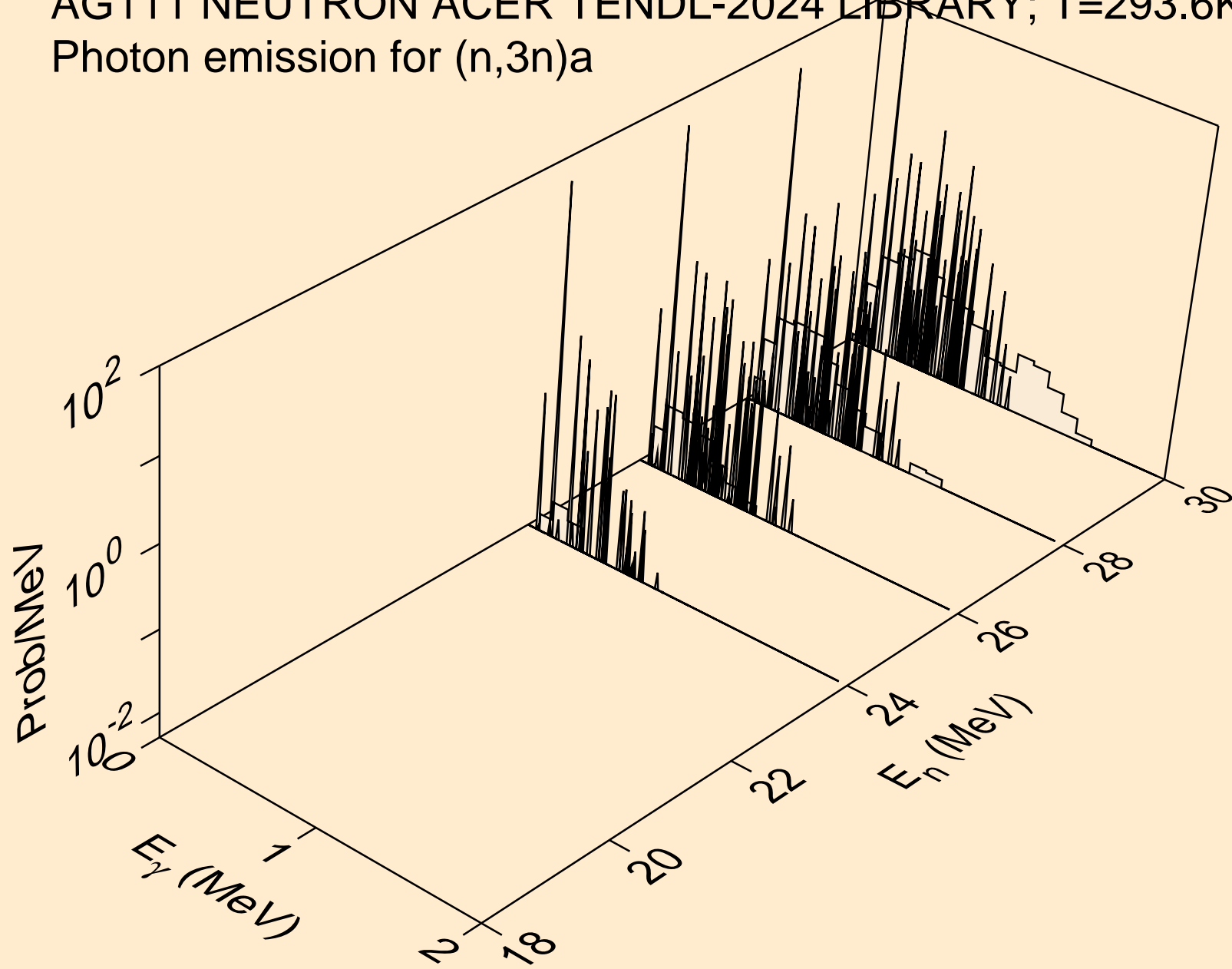

AG111 NEUTRON ACER TENDL-2024 LIBRARY; T=293.6K  
Photon emission for (n,n\*)p

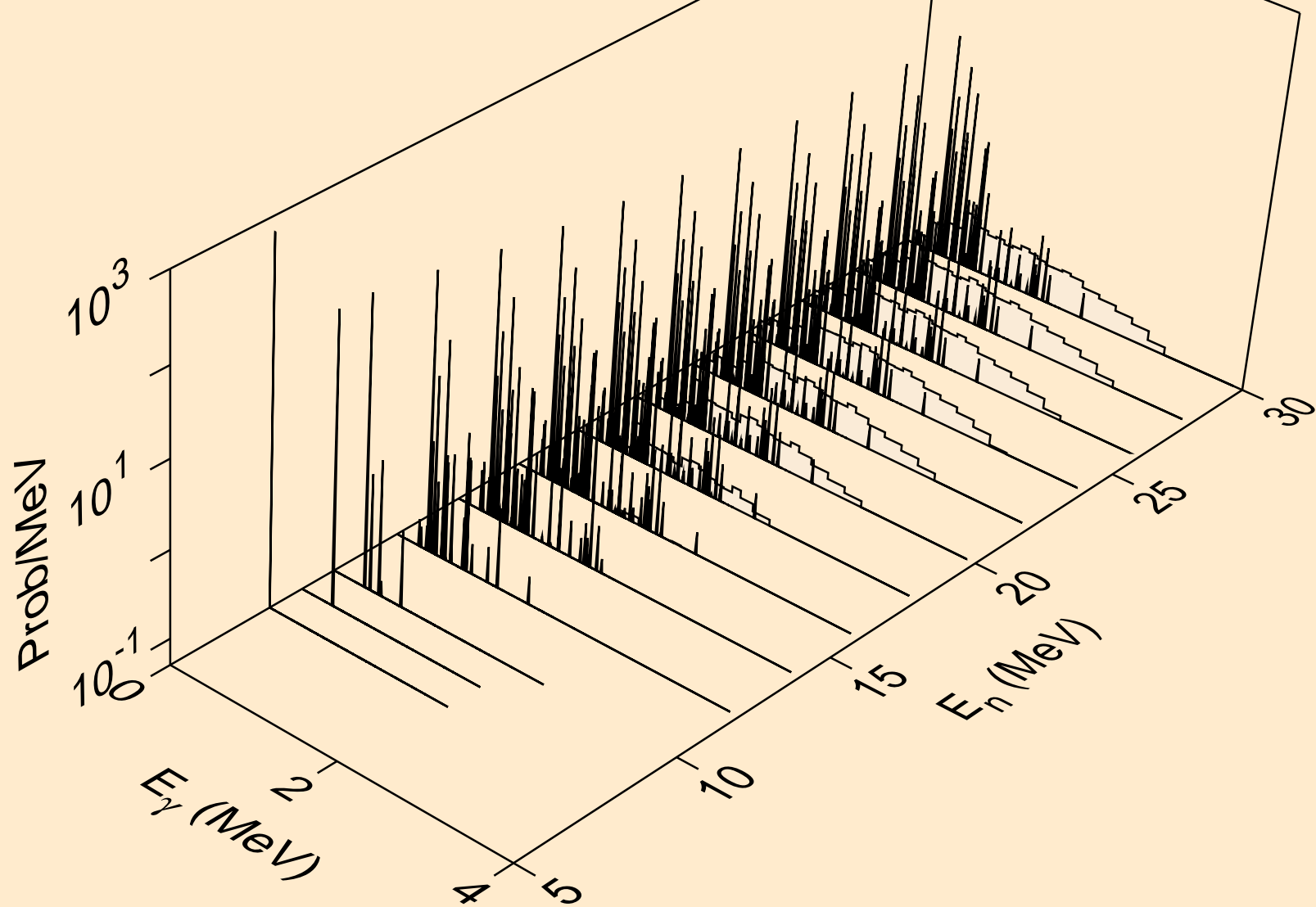

AG111 NEUTRON ACER TENDL-2024 LIBRARY; T=293.6K  
Photon emission for (n,n\*)2a

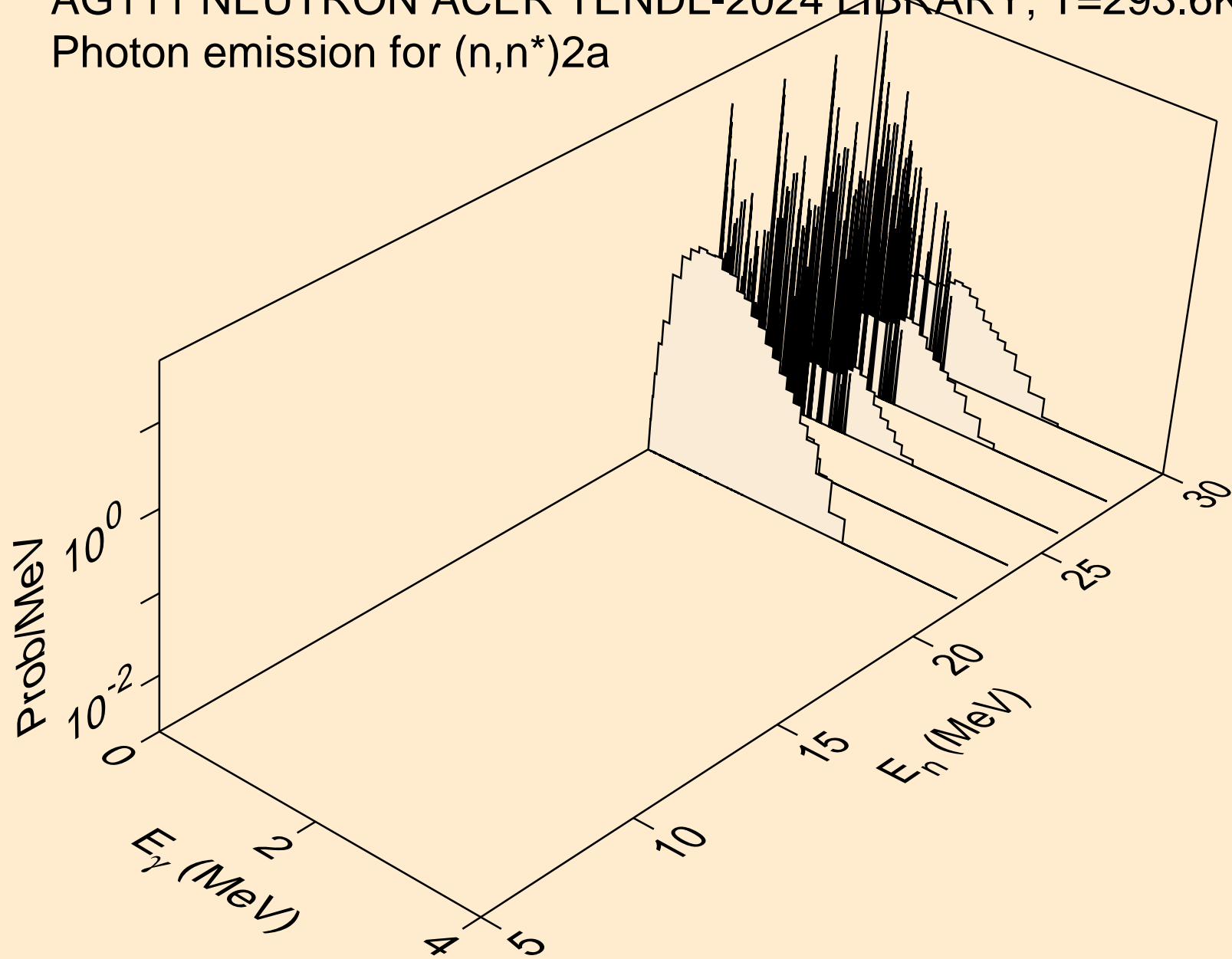

AG111 NEUTRON ACER TENDL-2024 LIBRARY; T=293.6K  
Photon emission for (n,n\*)d

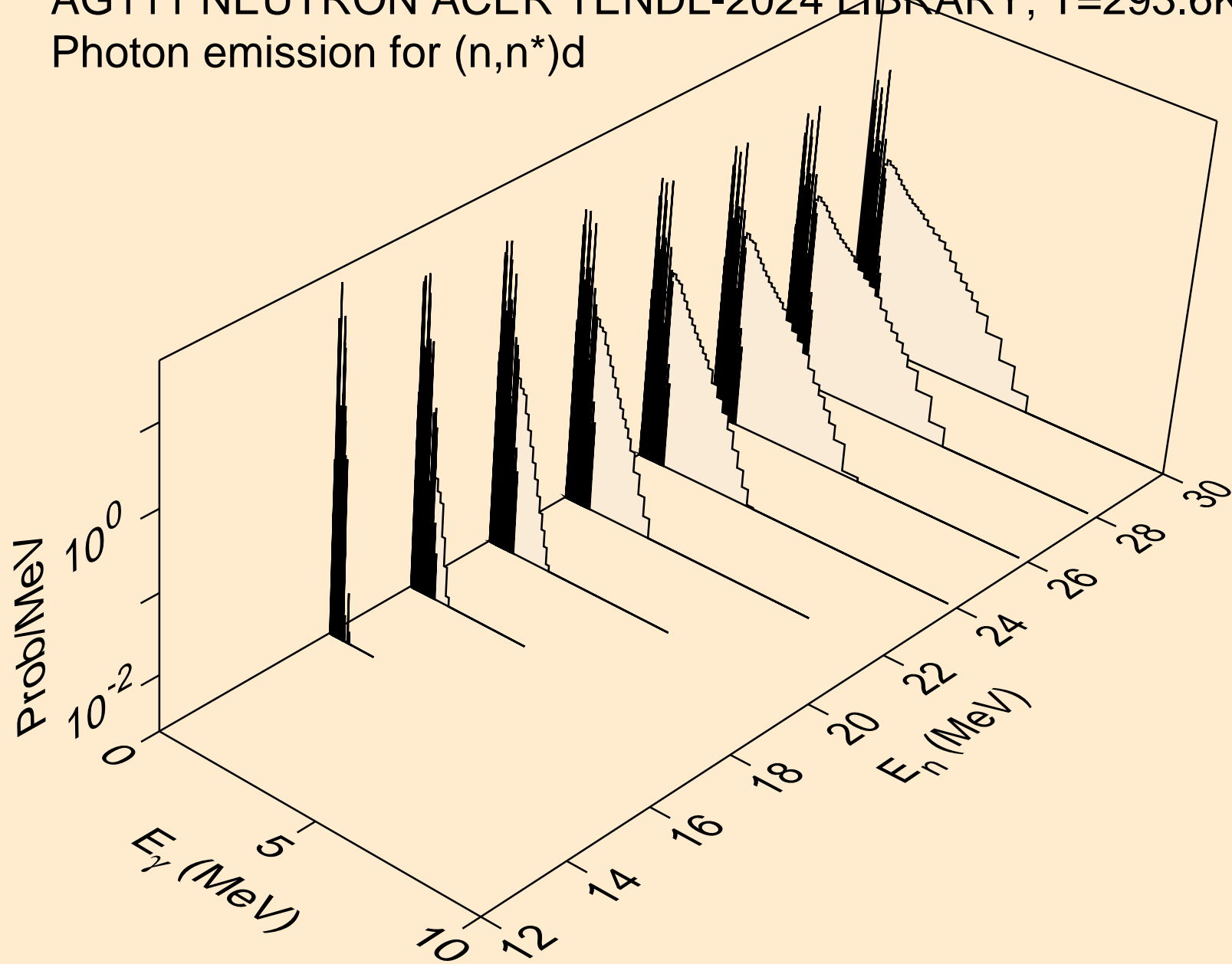

AG111 NEUTRON ACER TENDL-2024 LIBRARY; T=293.6K  
Photon emission for (n,n\*)t

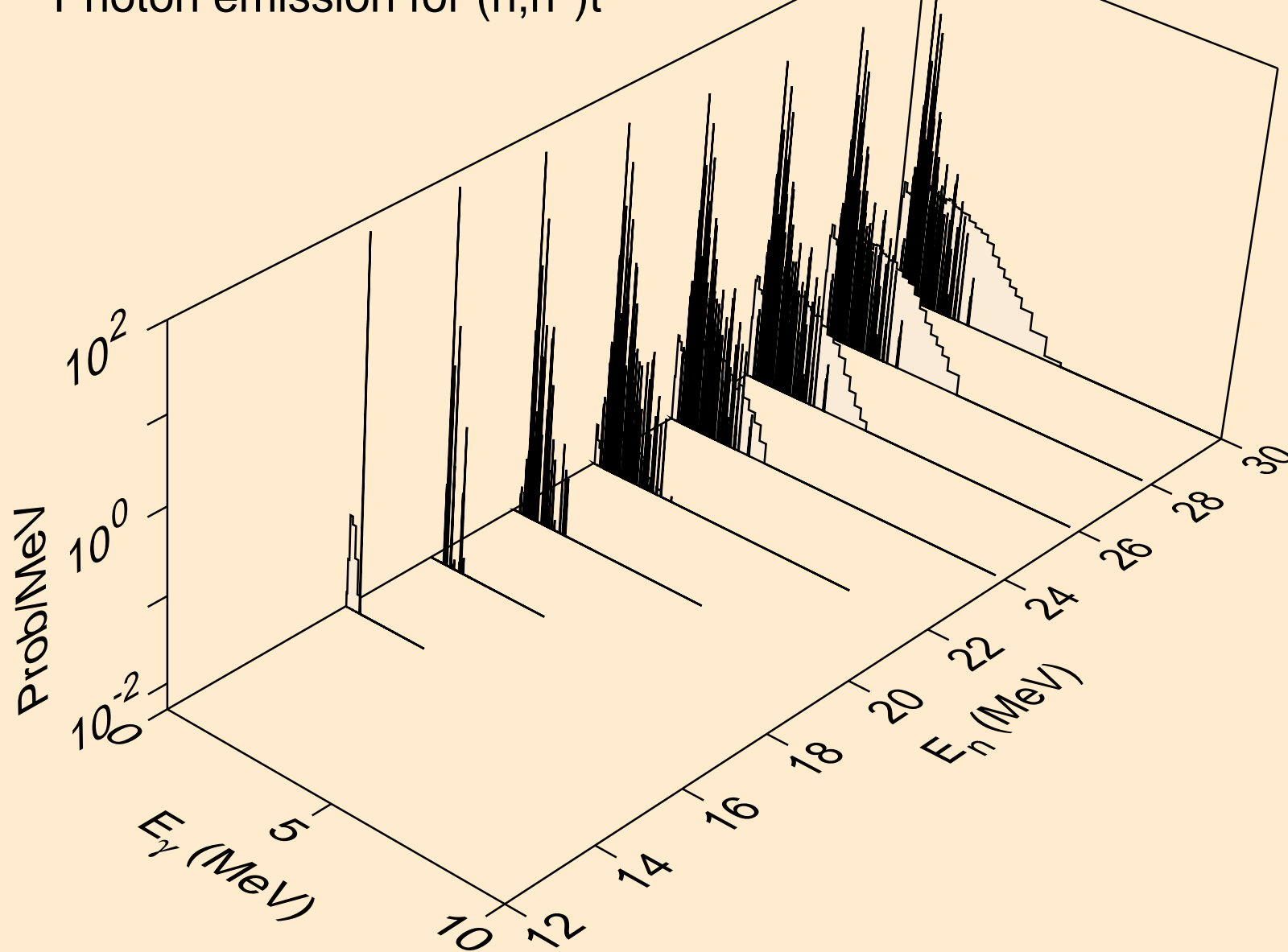

AG111 NEUTRON ACER TENDL-2024 LIBRARY; T=293.6K  
Photon emission for (n,n\*)he3

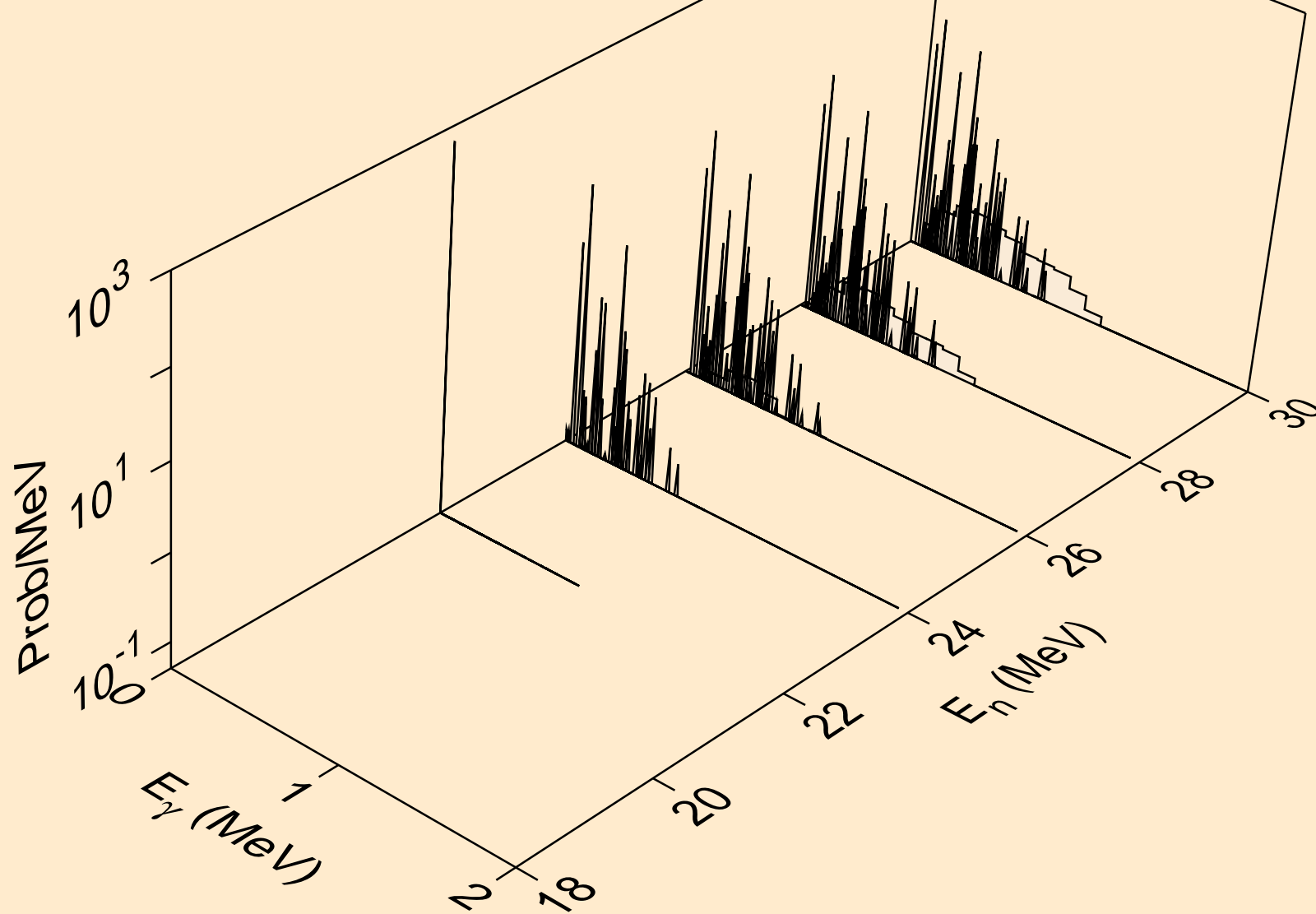

AG111 NEUTRON ACER TENDL-2024 LIBRARY; T=293.6K  
Photon emission for (n,4n)

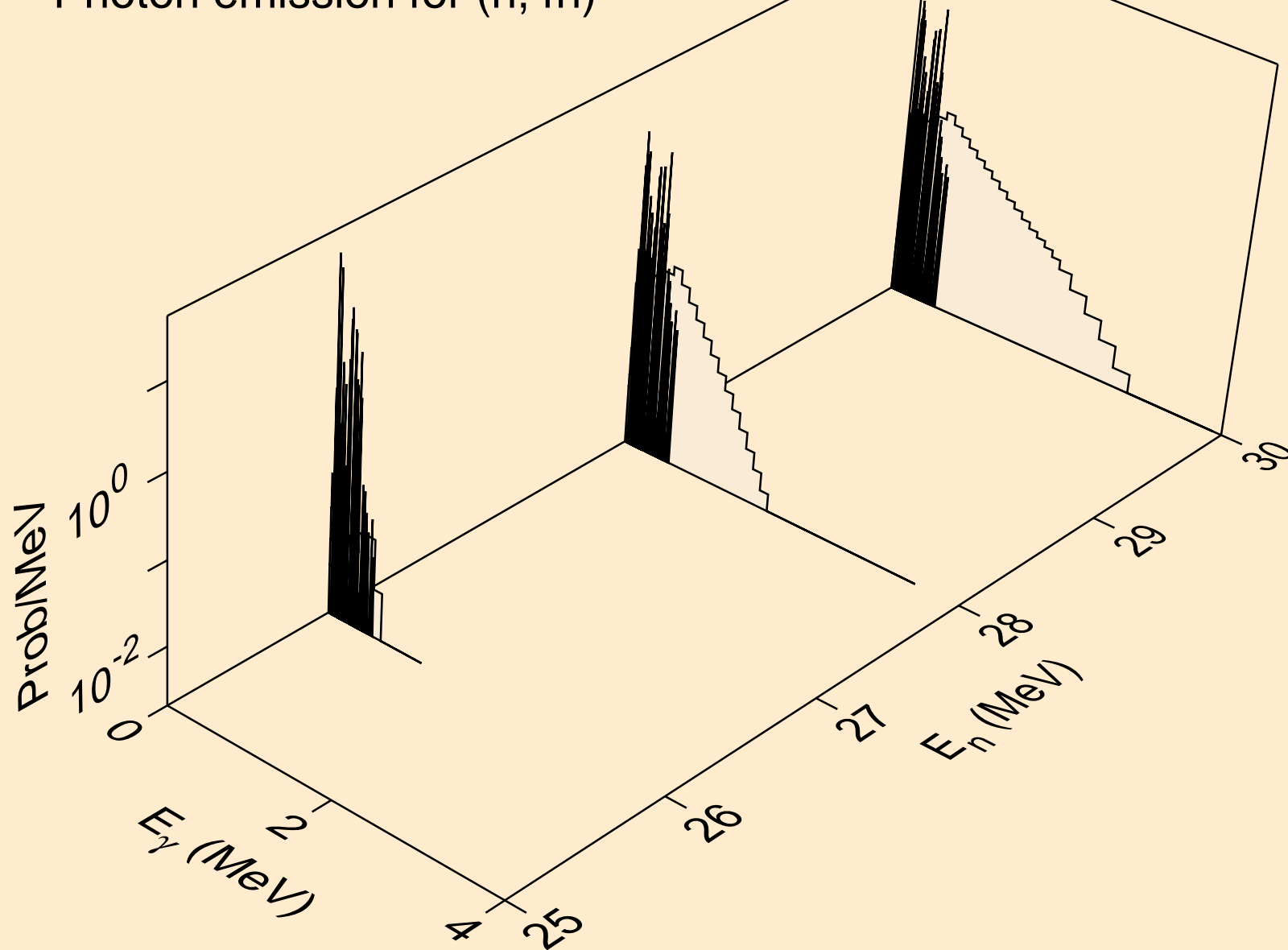

AG111 NEUTRON ACER TENDL-2024 LIBRARY; T=293.6K  
Photon emission for (n,2np)

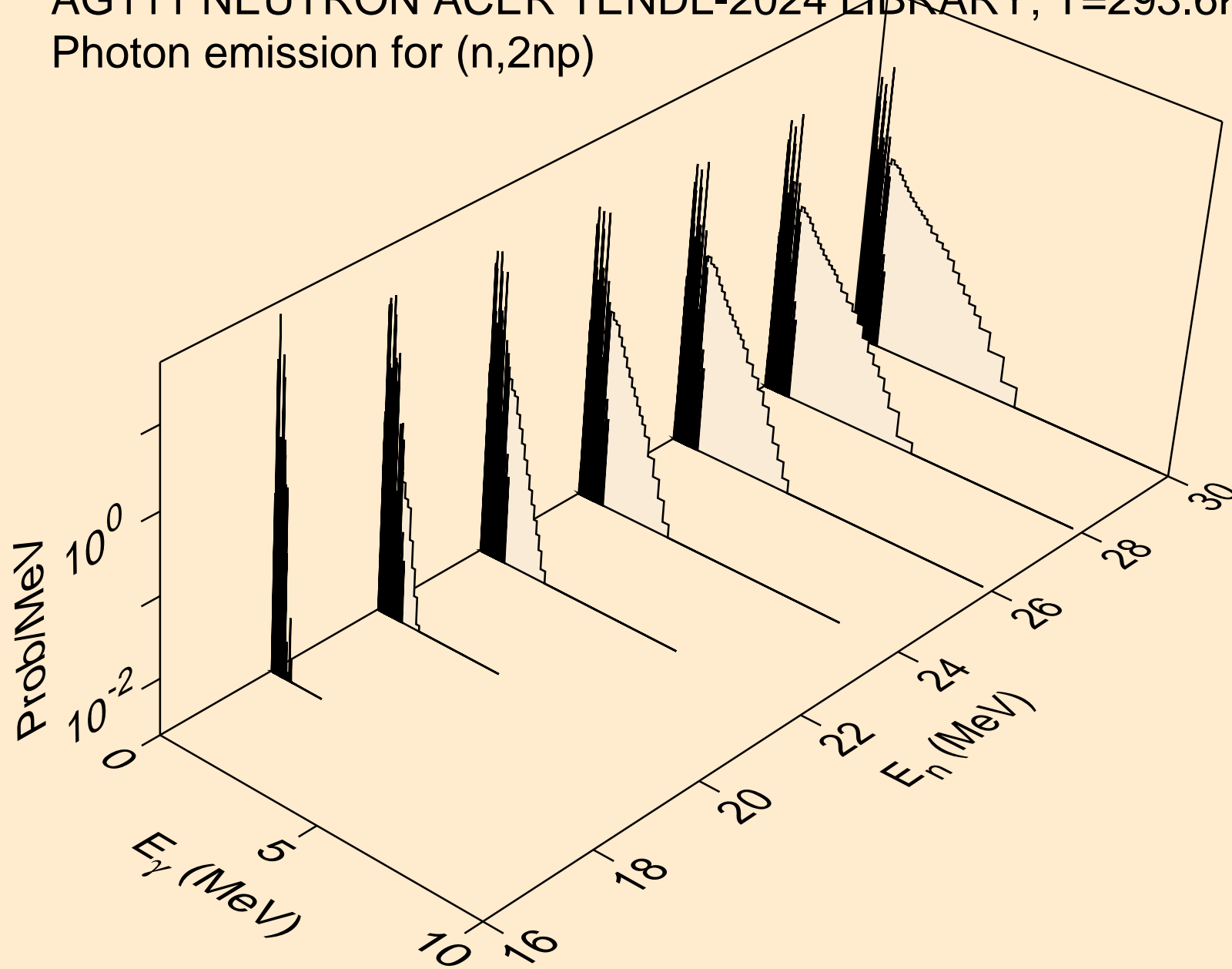

AG111 NEUTRON ACER TENDL-2024 LIBRARY; T=293.6K  
Photon emission for (n,3np)

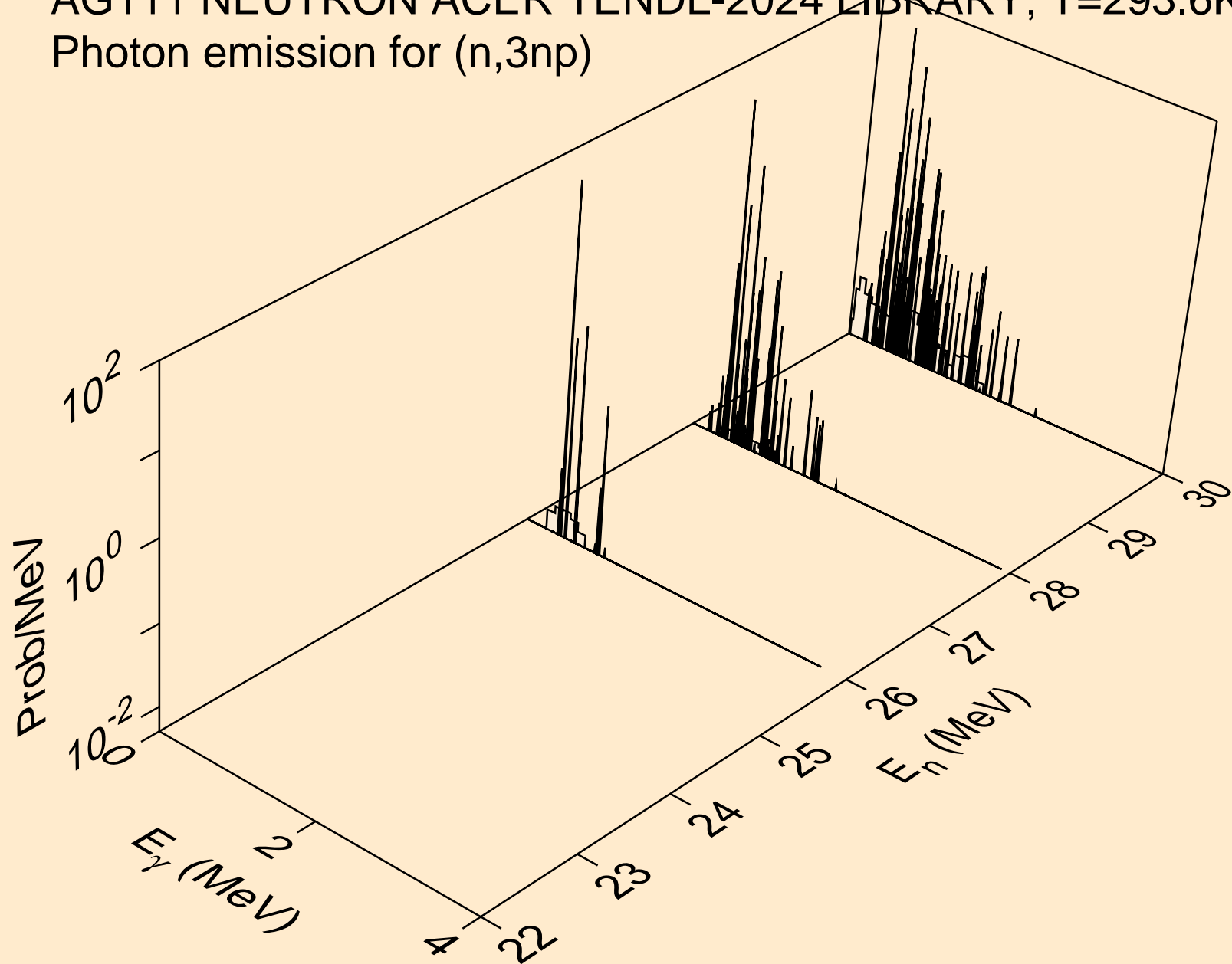

AG111 NEUTRON ACER TENDL-2024 LIBRARY; T=293.6K  
Photon emission for (n,n2p)

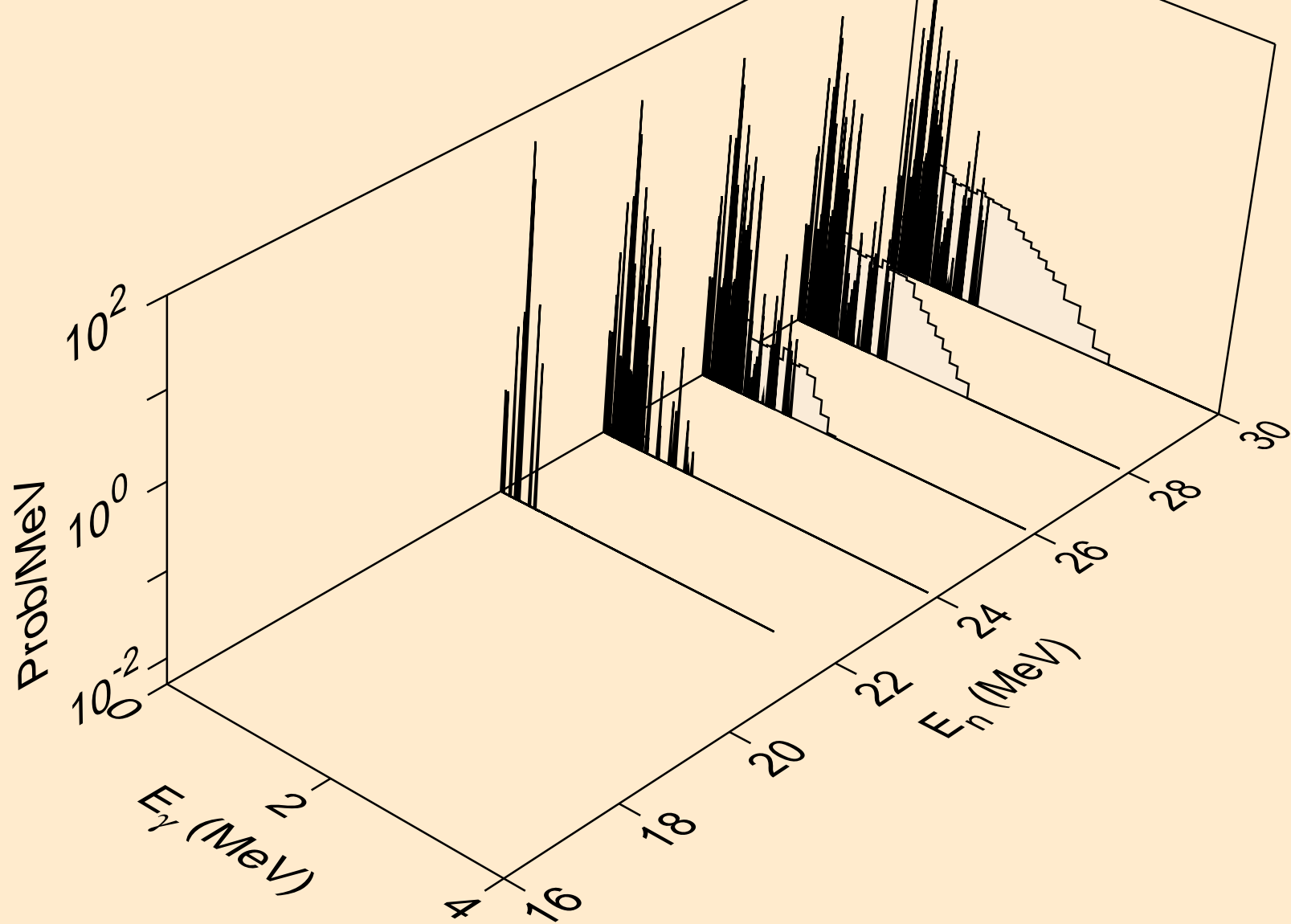

AG111 NEUTRON ACER TENDL-2024 LIBRARY; T=293.6K  
Photon emission for (n,npa)

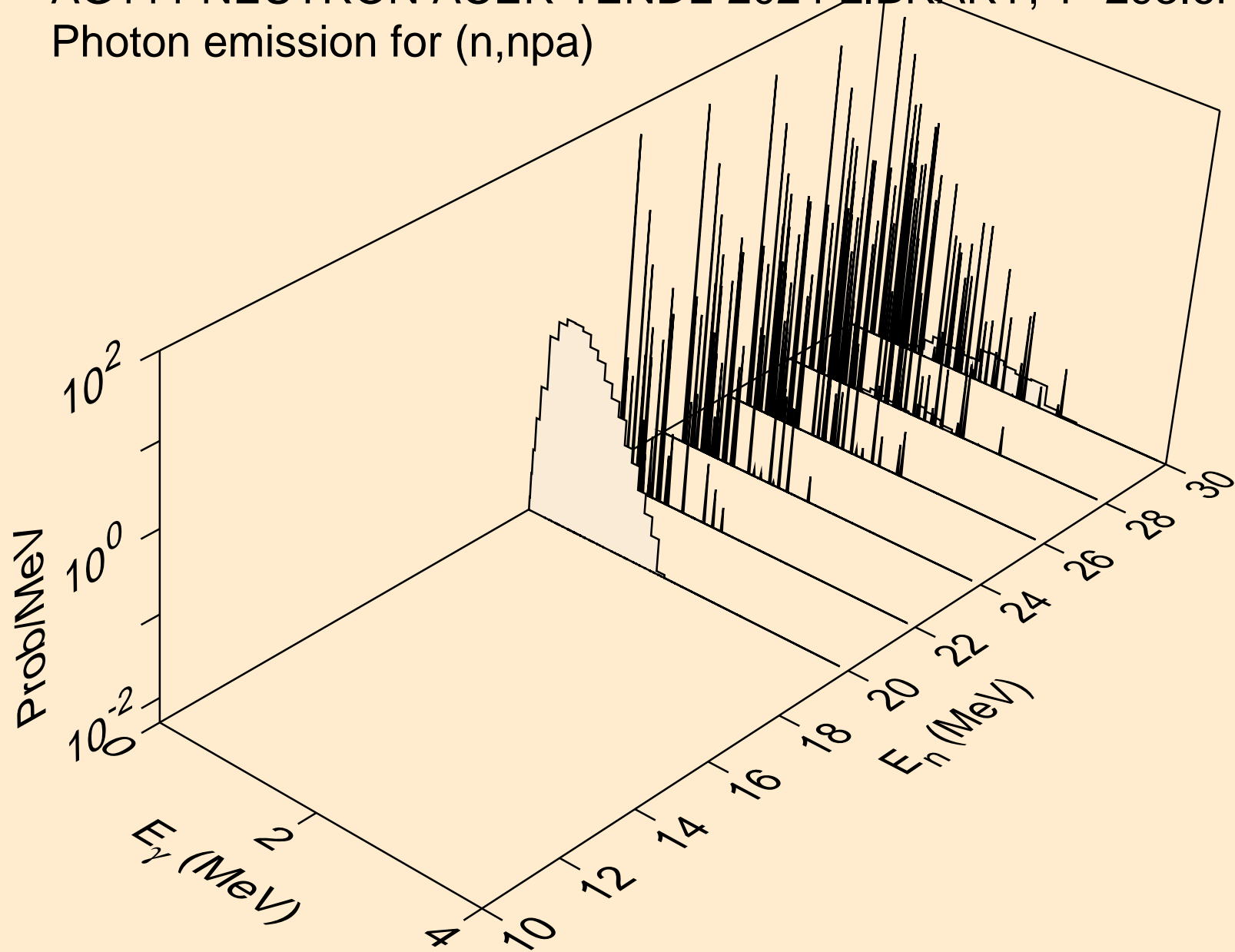

AG111 NEUTRON ACER TENDL-2024 LIBRARY; T=293.6K  
Photon emission for (n,n\*c)

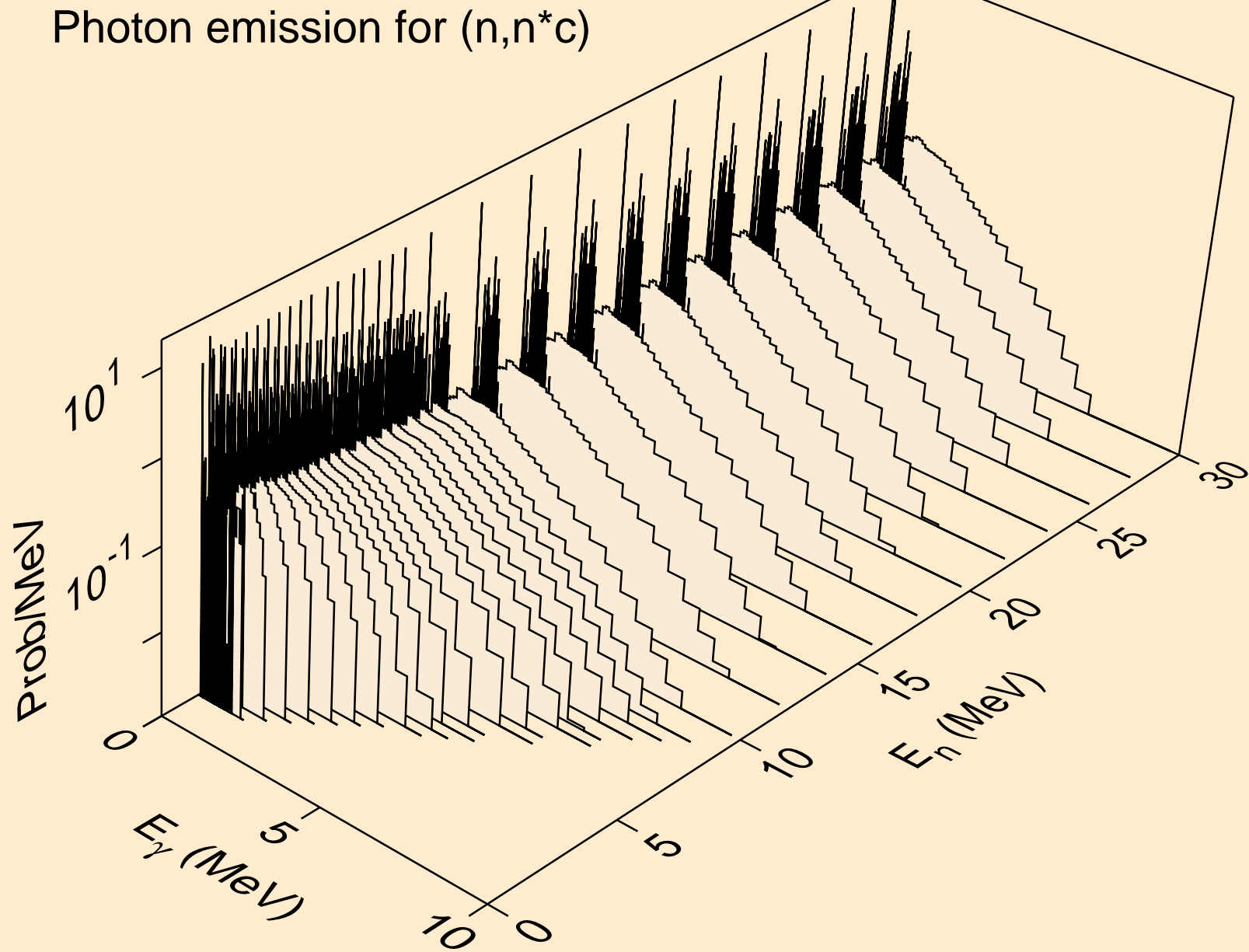

AG111 NEUTRON ACER TENDL-2024 LIBRARY; T=293.6K  
Photon emission for (n,gma)

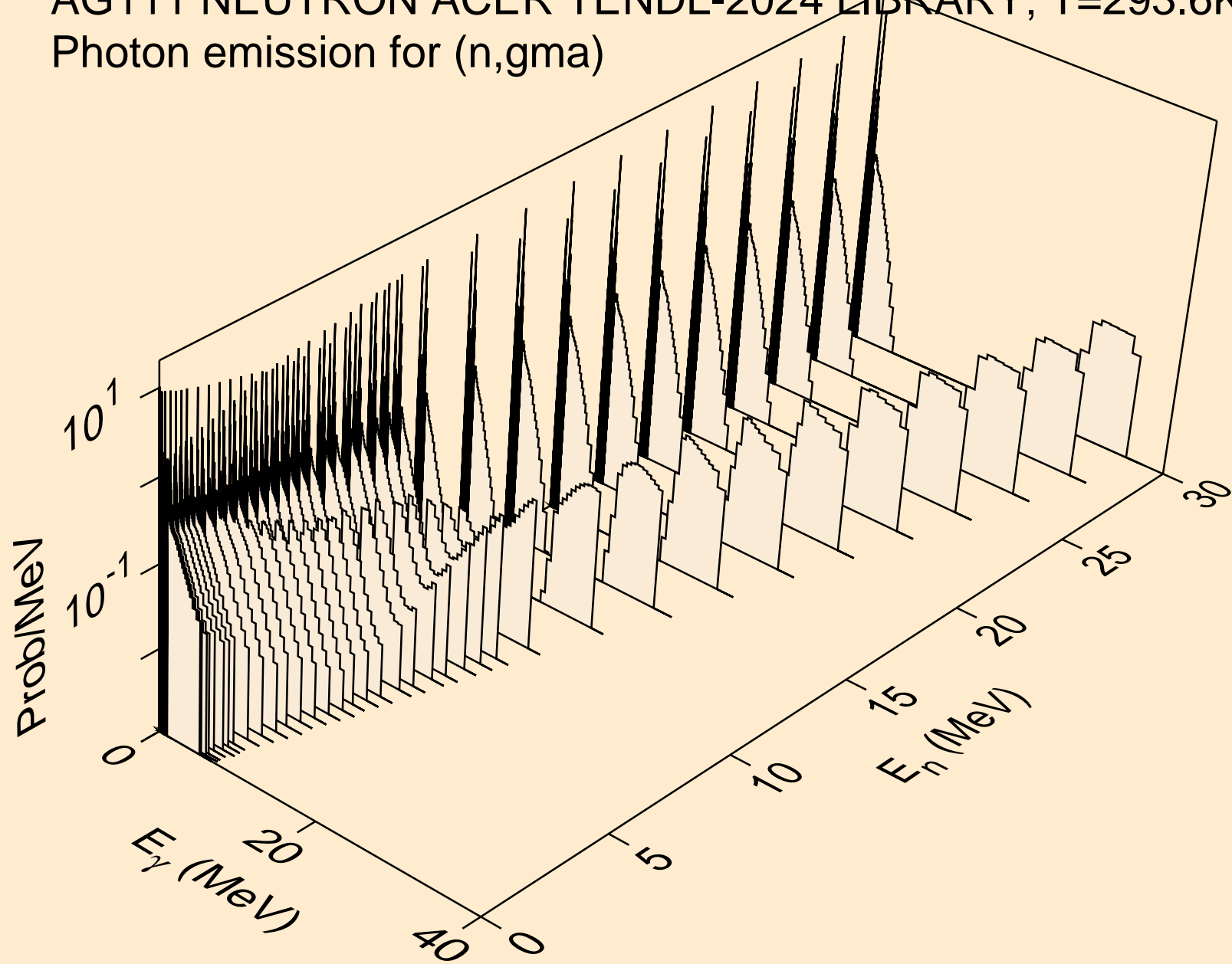

AG111 NEUTRON ACER TENDL-2024 LIBRARY; T=293.6K  
Photon emission for (n,p)

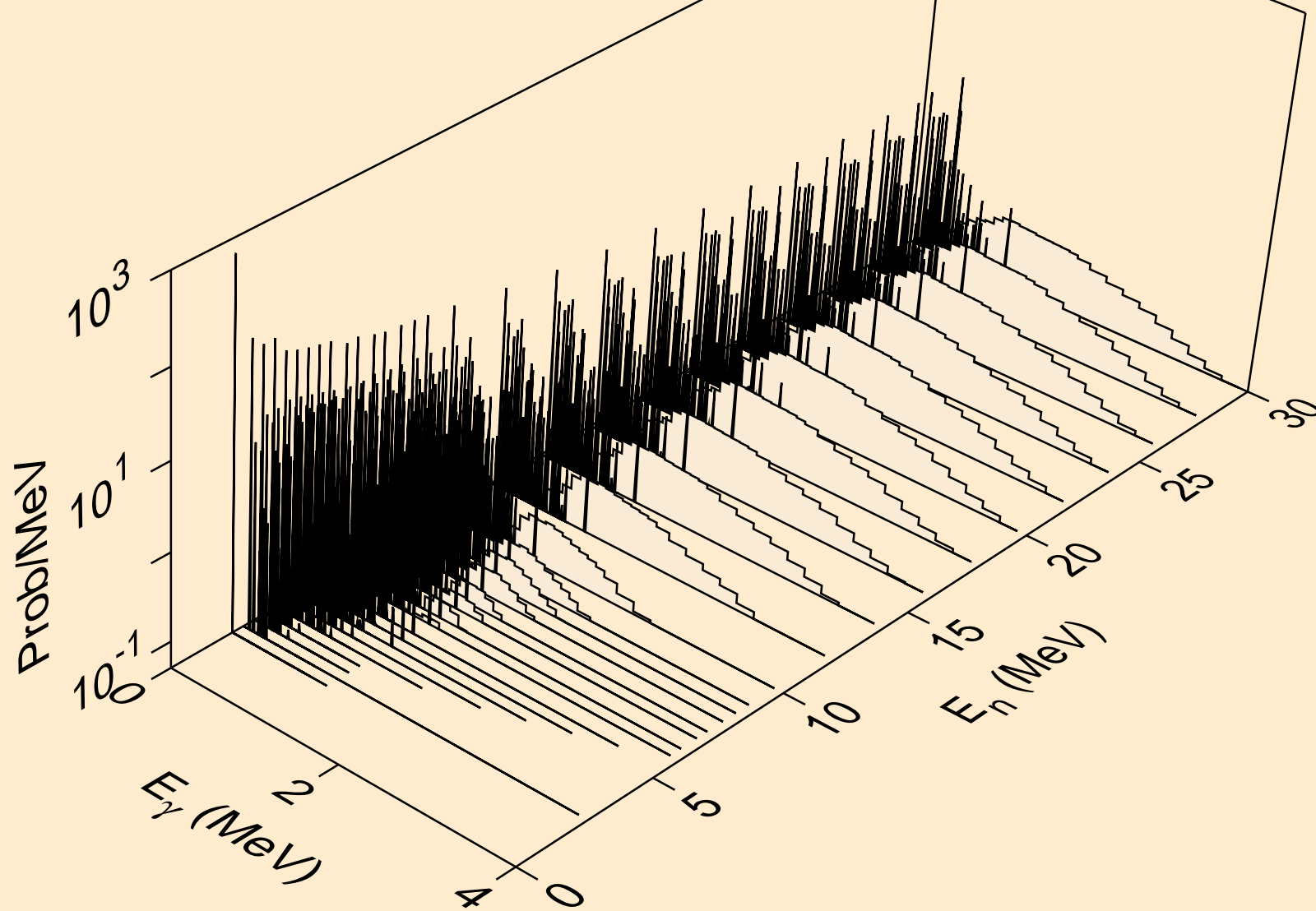

AG111 NEUTRON ACER TENDL-2024 LIBRARY; T=293.6K  
Photon emission for (n,d)

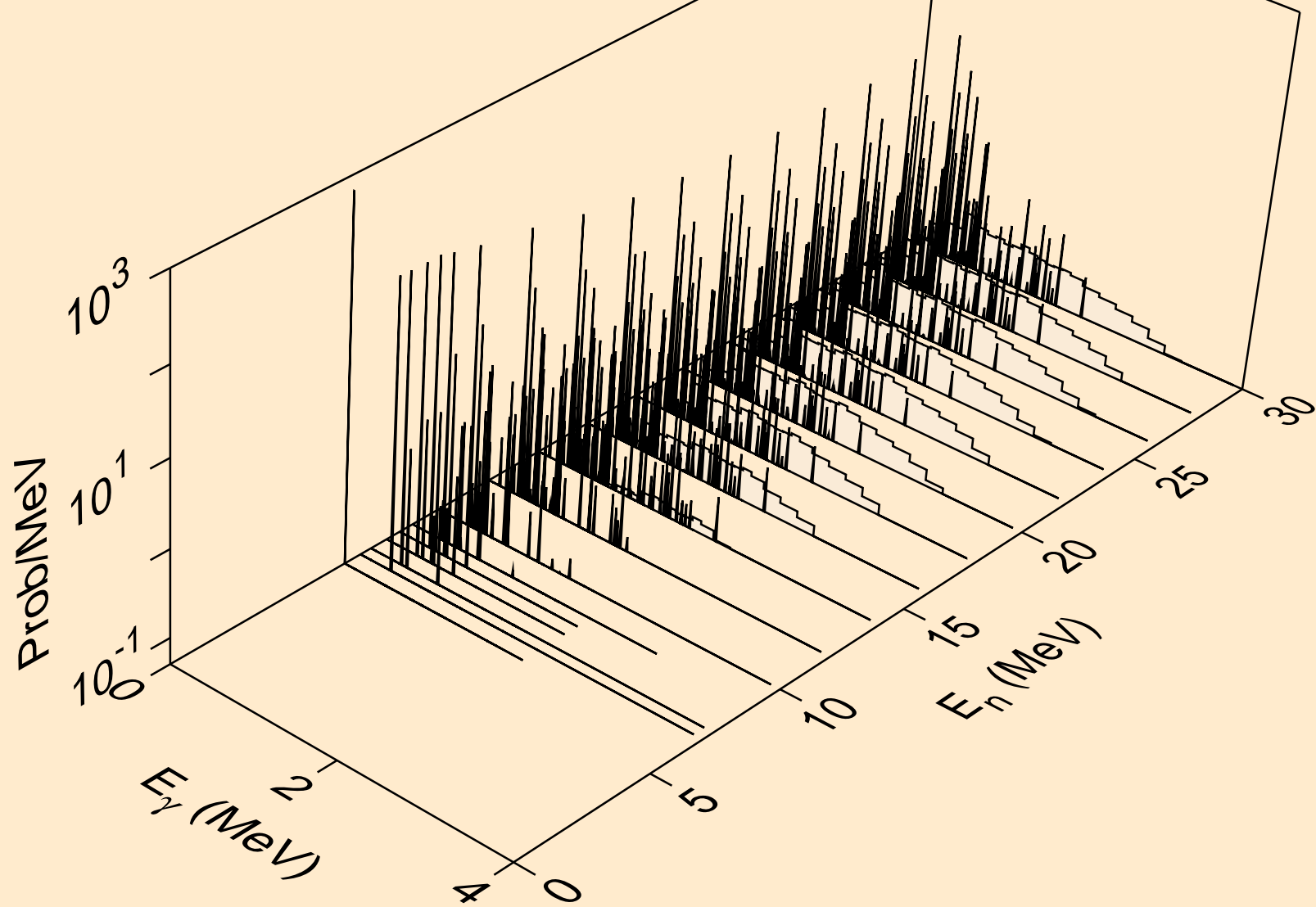

AG111 NEUTRON ACER TENDL-2024 LIBRARY; T=293.6K  
Photon emission for (n,t)

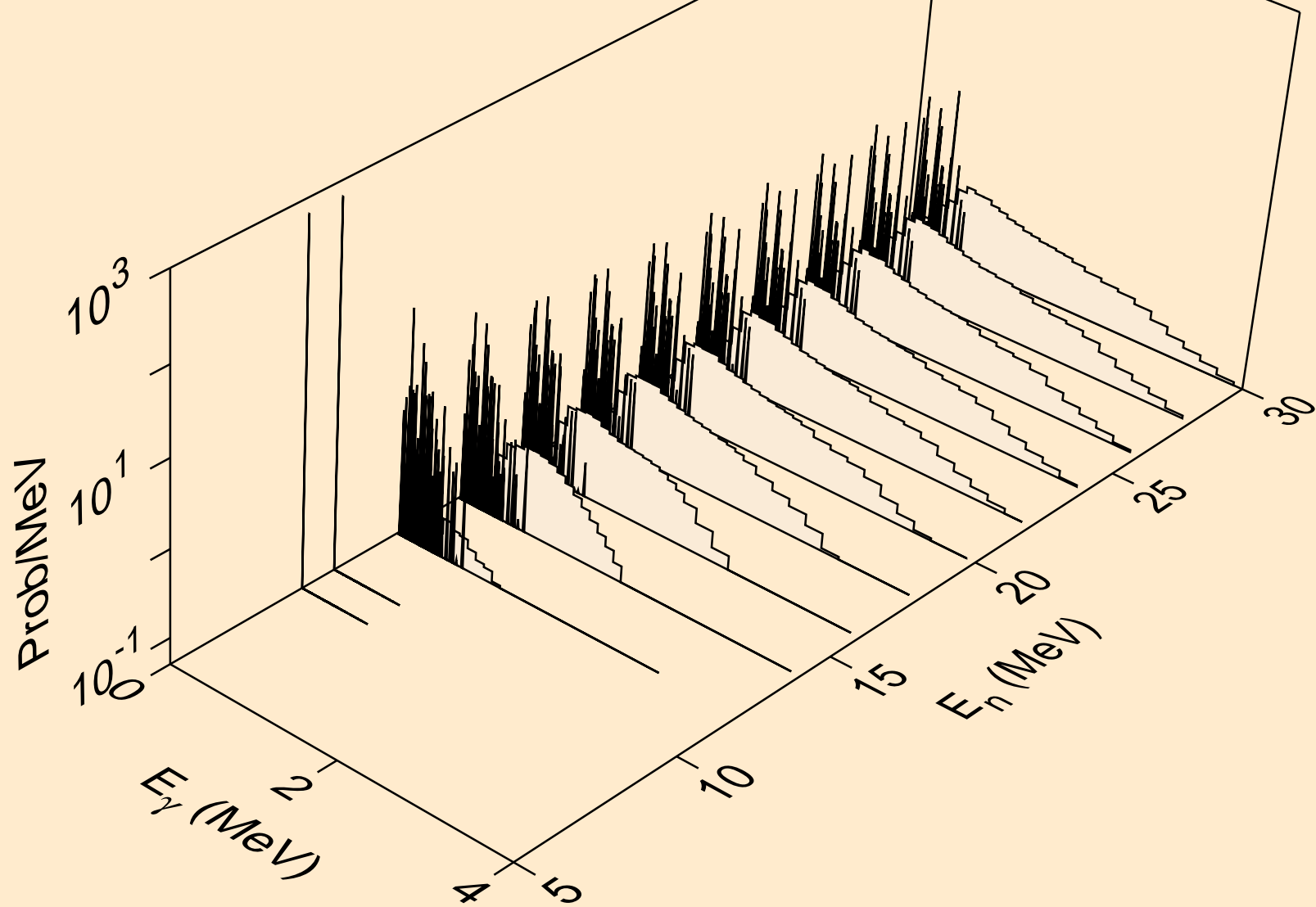

AG111 NEUTRON ACER TENDL-2024 LIBRARY; T=293.6K  
Photon emission for (n,he3)

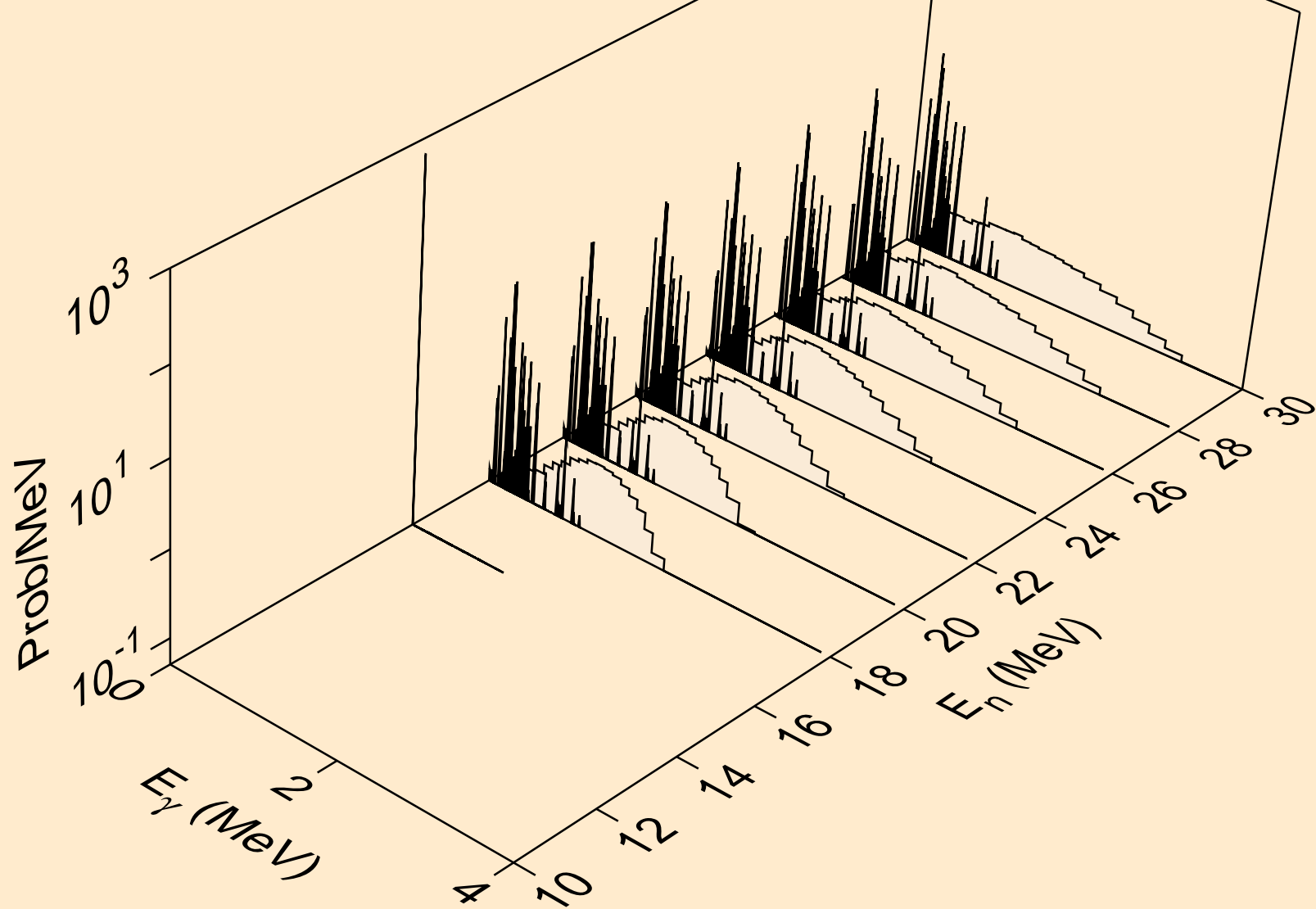

AG111 NEUTRON ACER TENDL-2024 LIBRARY; T=293.6K  
Photon emission for (n,a)

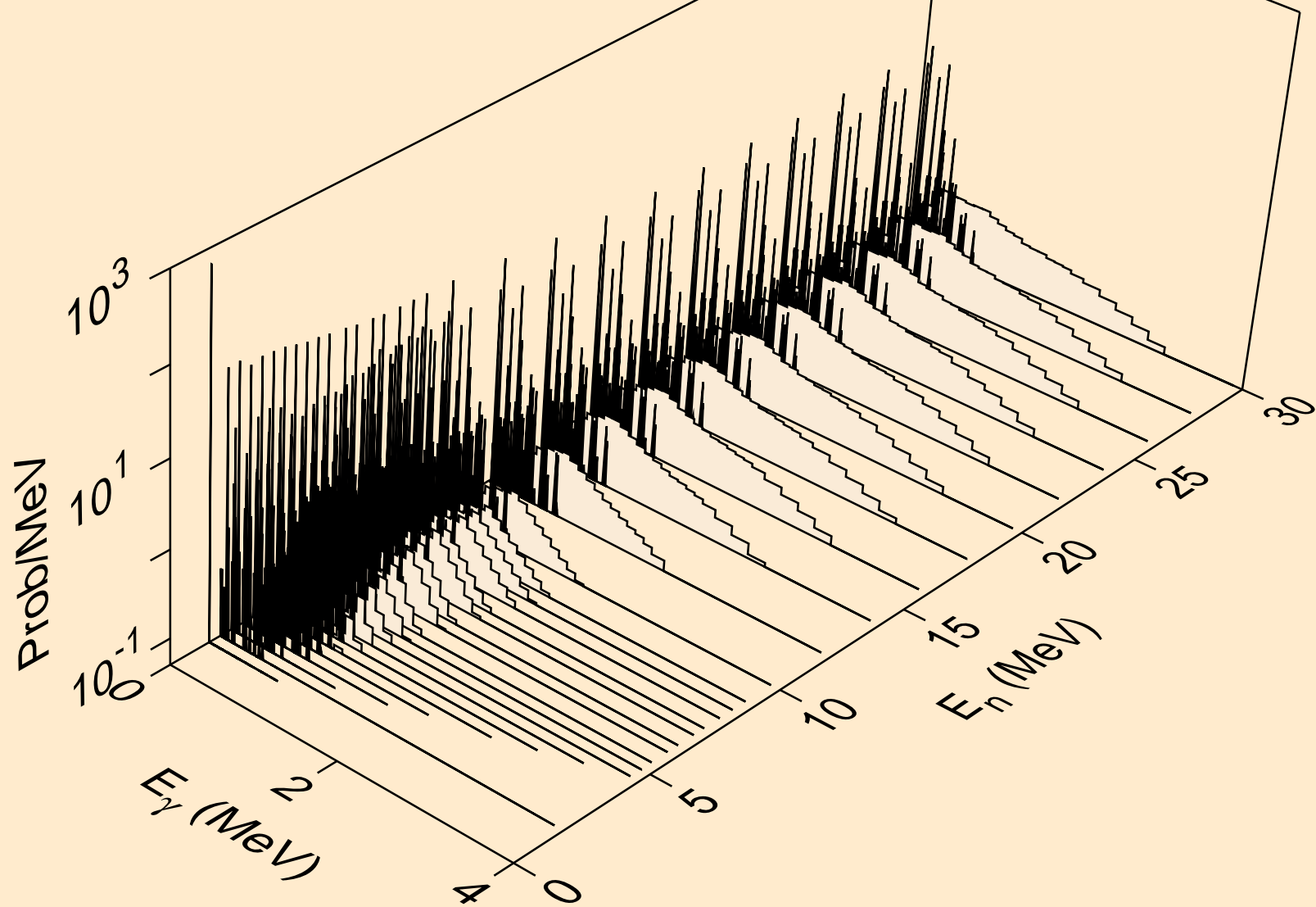

AG111 NEUTRON ACER TENDL-2024 LIBRARY; T=293.6K  
Photon emission for (n,2a)

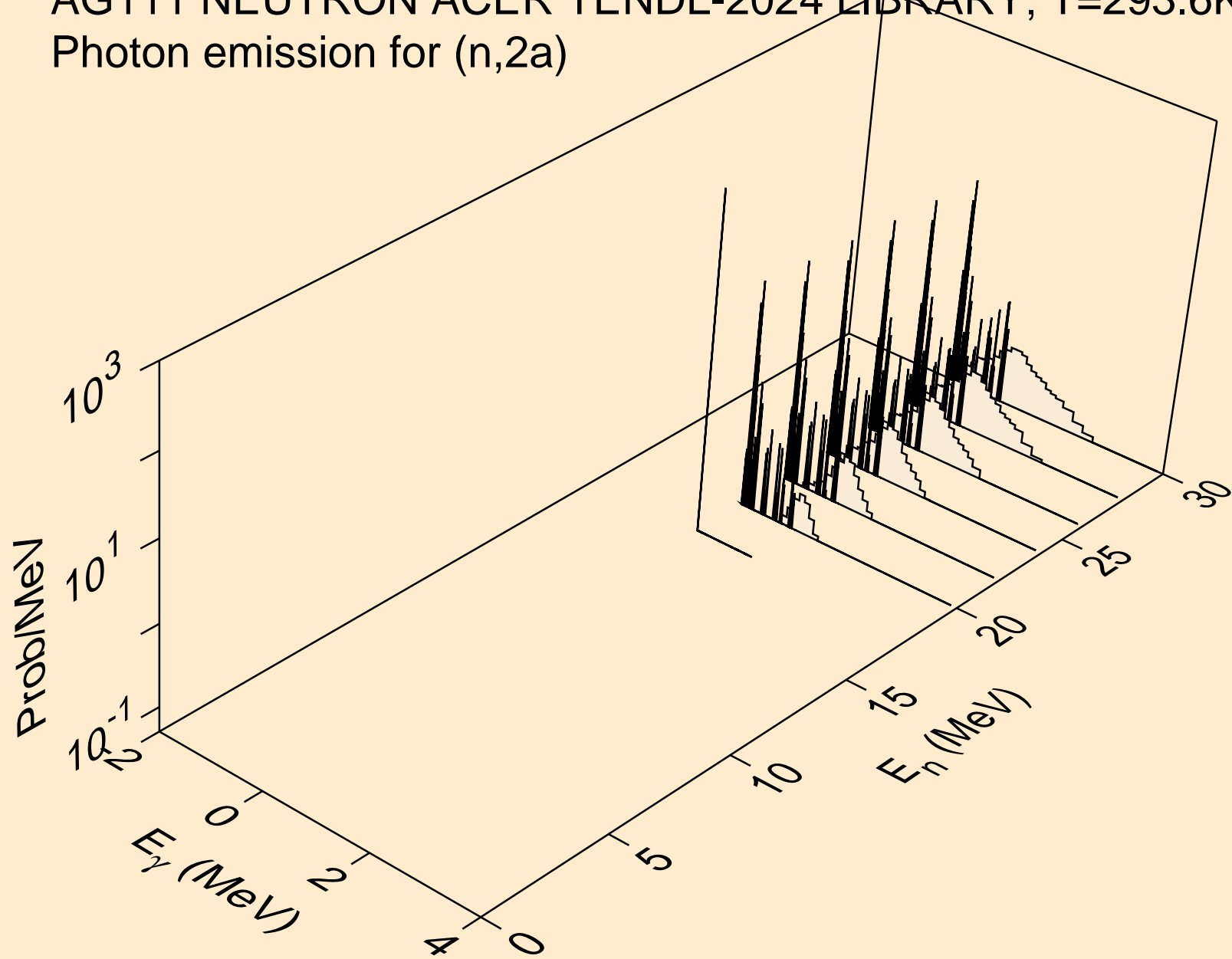

AG111 NEUTRON ACER TENDL-2024 LIBRARY; T=293.6K  
Photon emission for (n,2p)

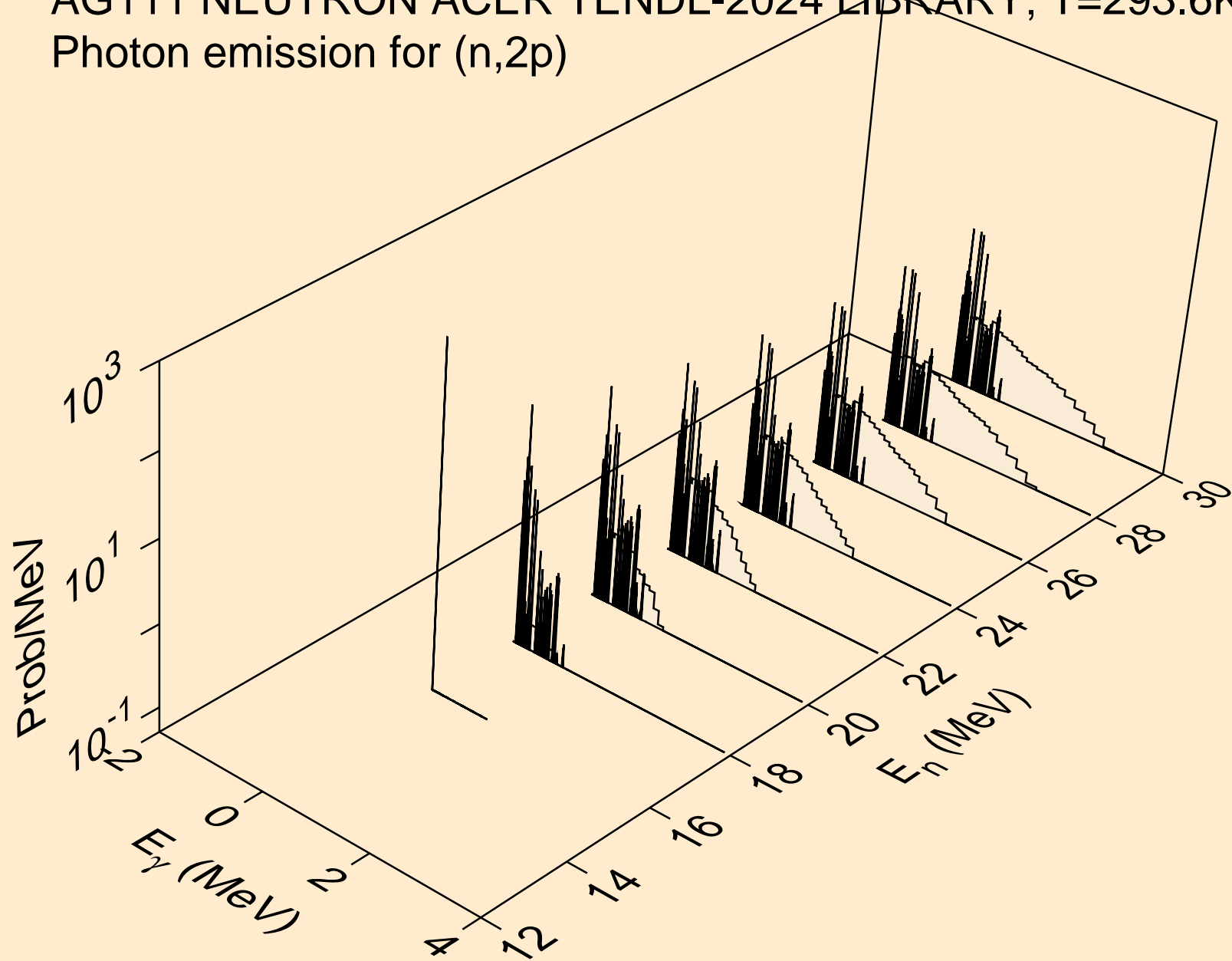

AG111 NEUTRON ACER TENDL-2024 LIBRARY; T=293.6K  
Photon emission for (n,p)

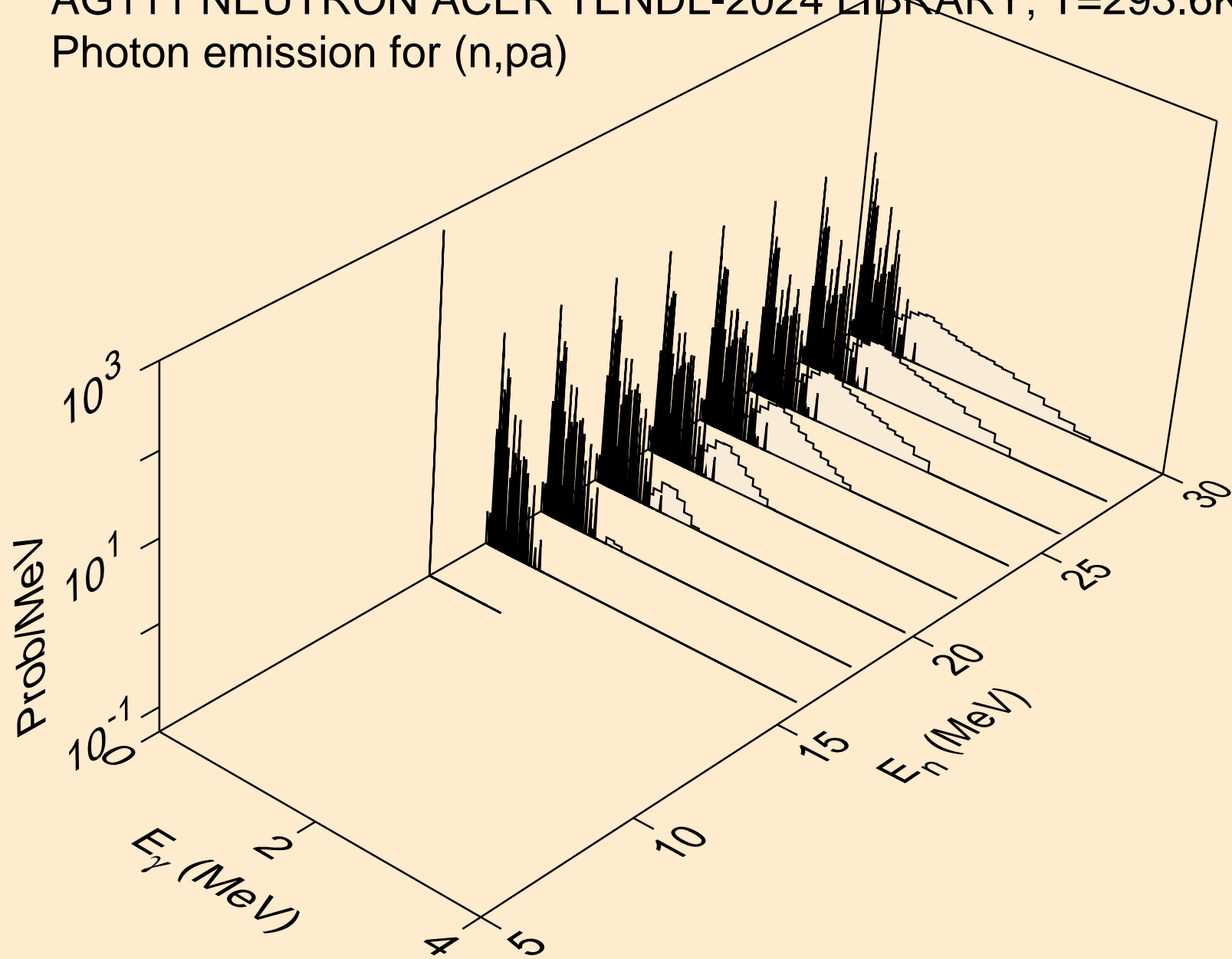

AG111 NEUTRON ACER TENDL-2024 LIBRARY; T=293.6K  
Photon emission for (n,pd)

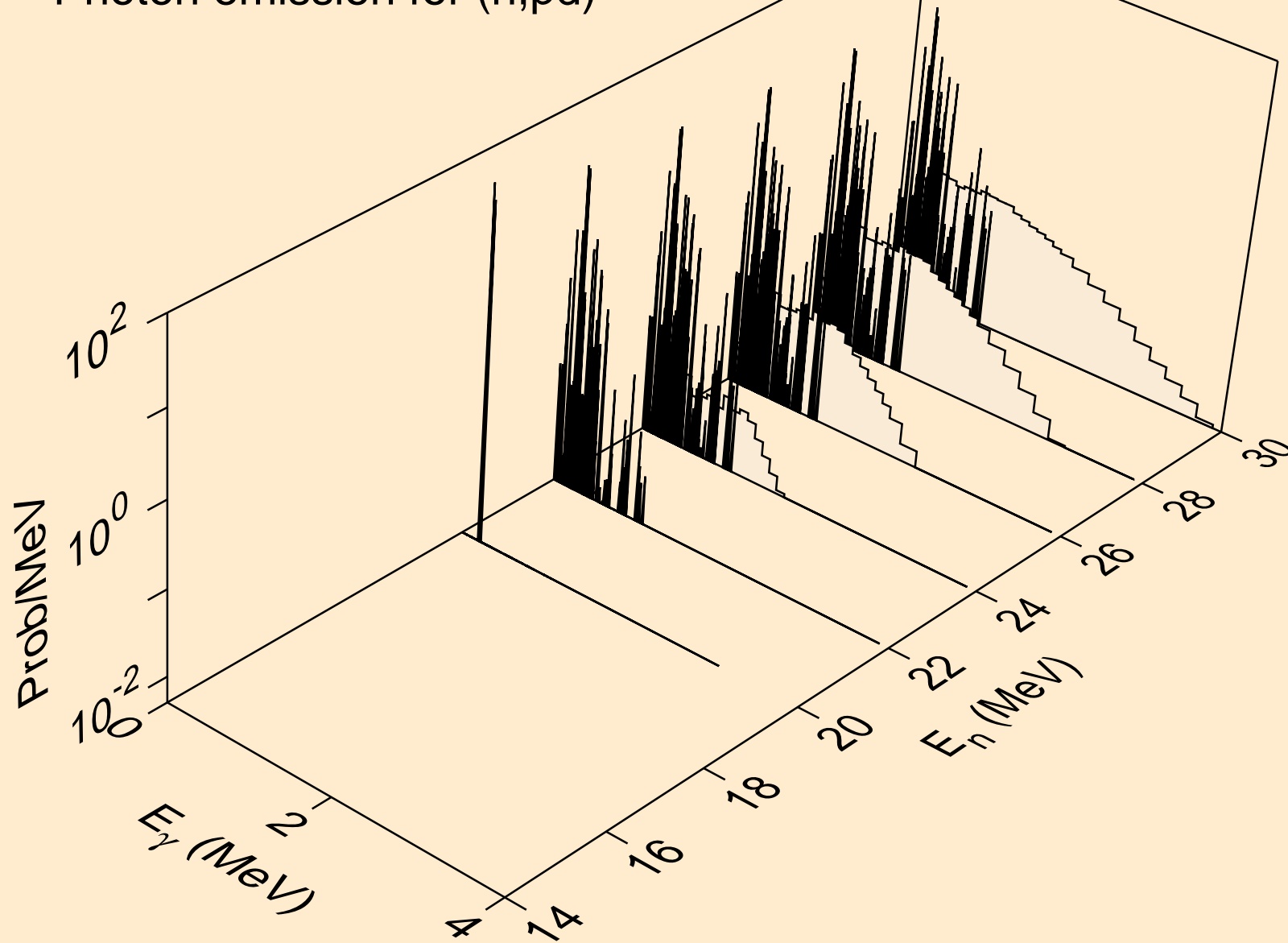

AG111 NEUTRON ACER TENDL-2024 LIBRARY; T=293.6K  
Photon emission for (n,pt)

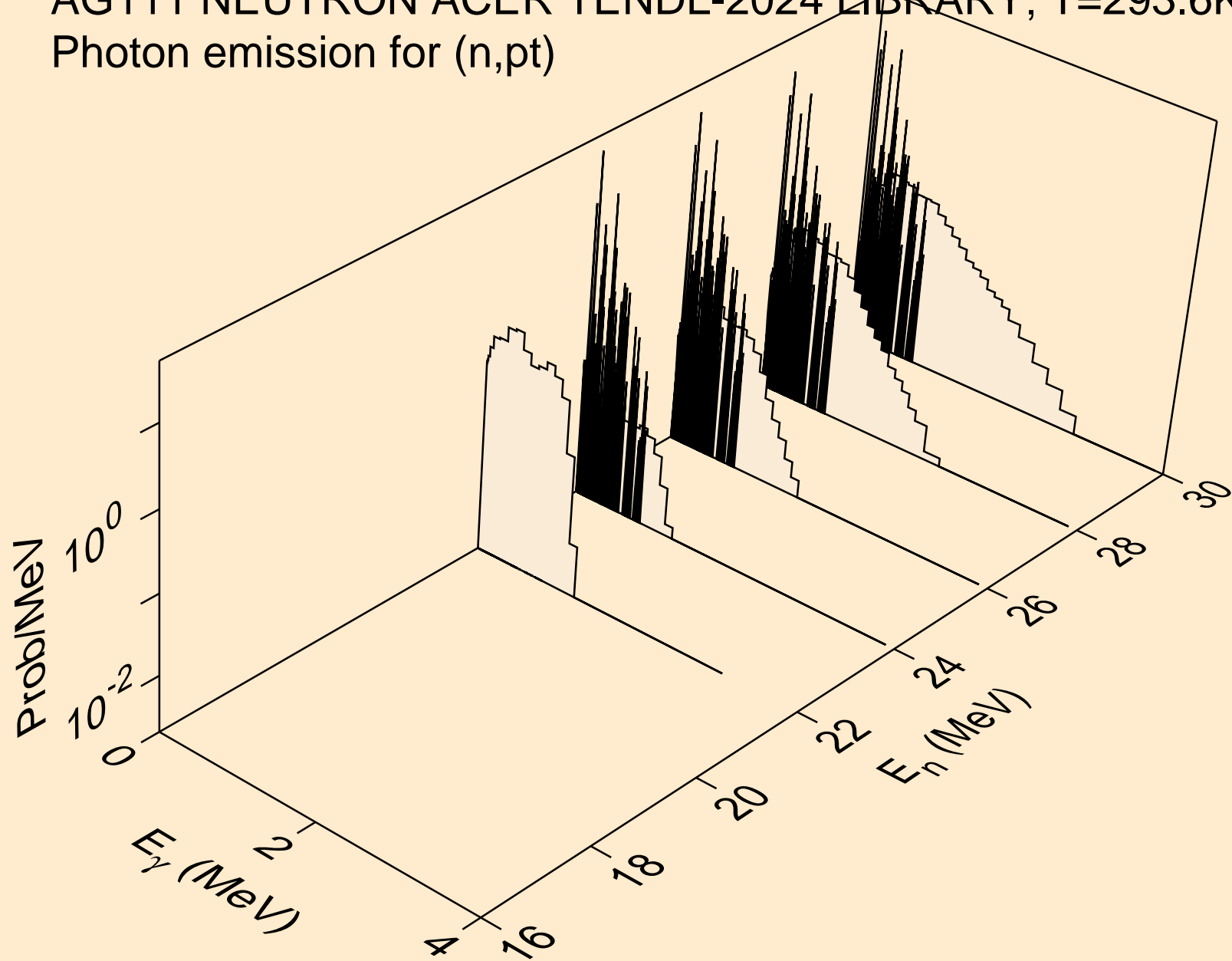

AG111 NEUTRON ACER TENDL-2024 LIBRARY; T=293.6K  
Photon emission for (n,da)

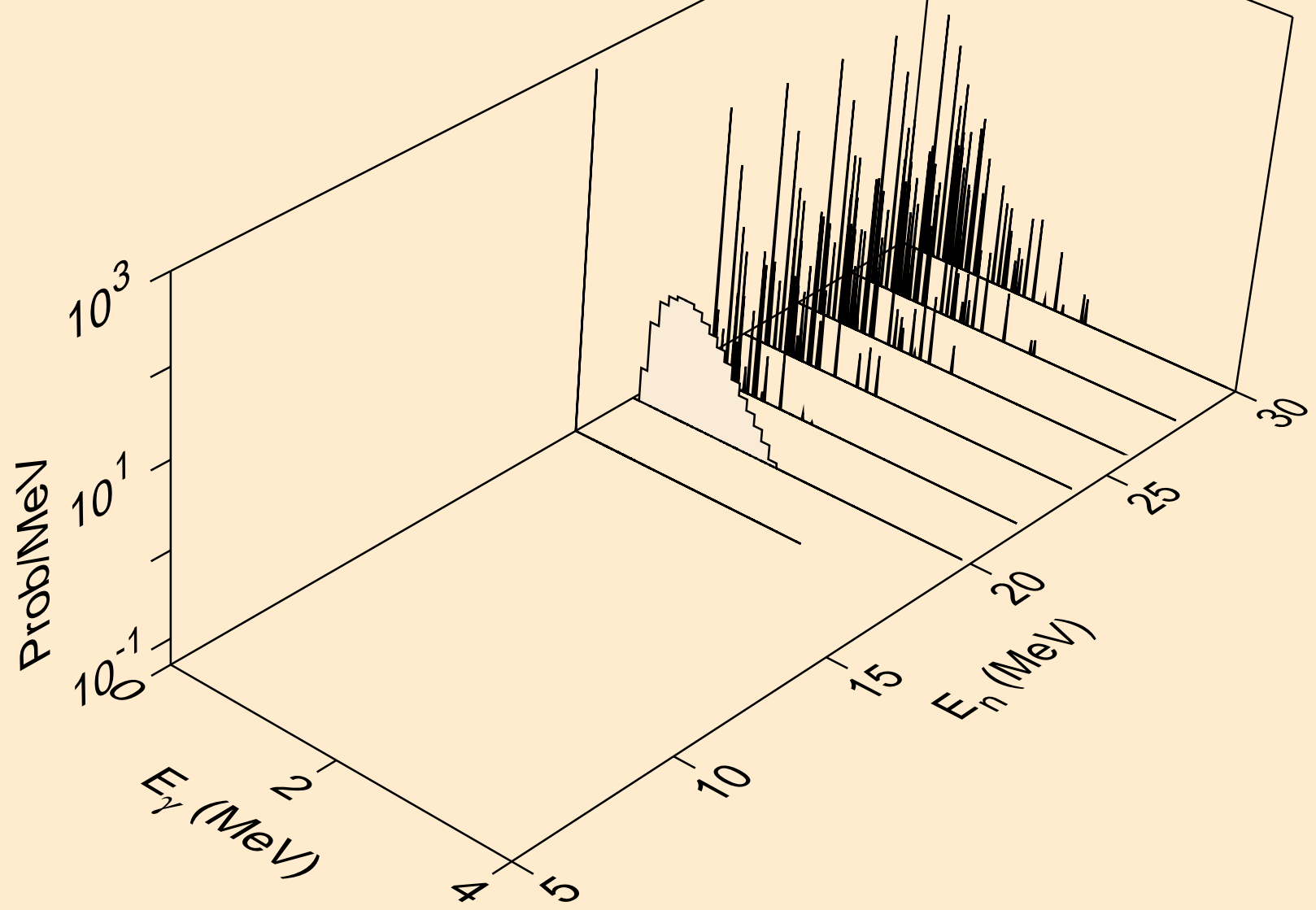

AG111 NEUTRON ACER TENDL-2024 LIBRARY; T=293.6K  
thermal capture photon spectrum

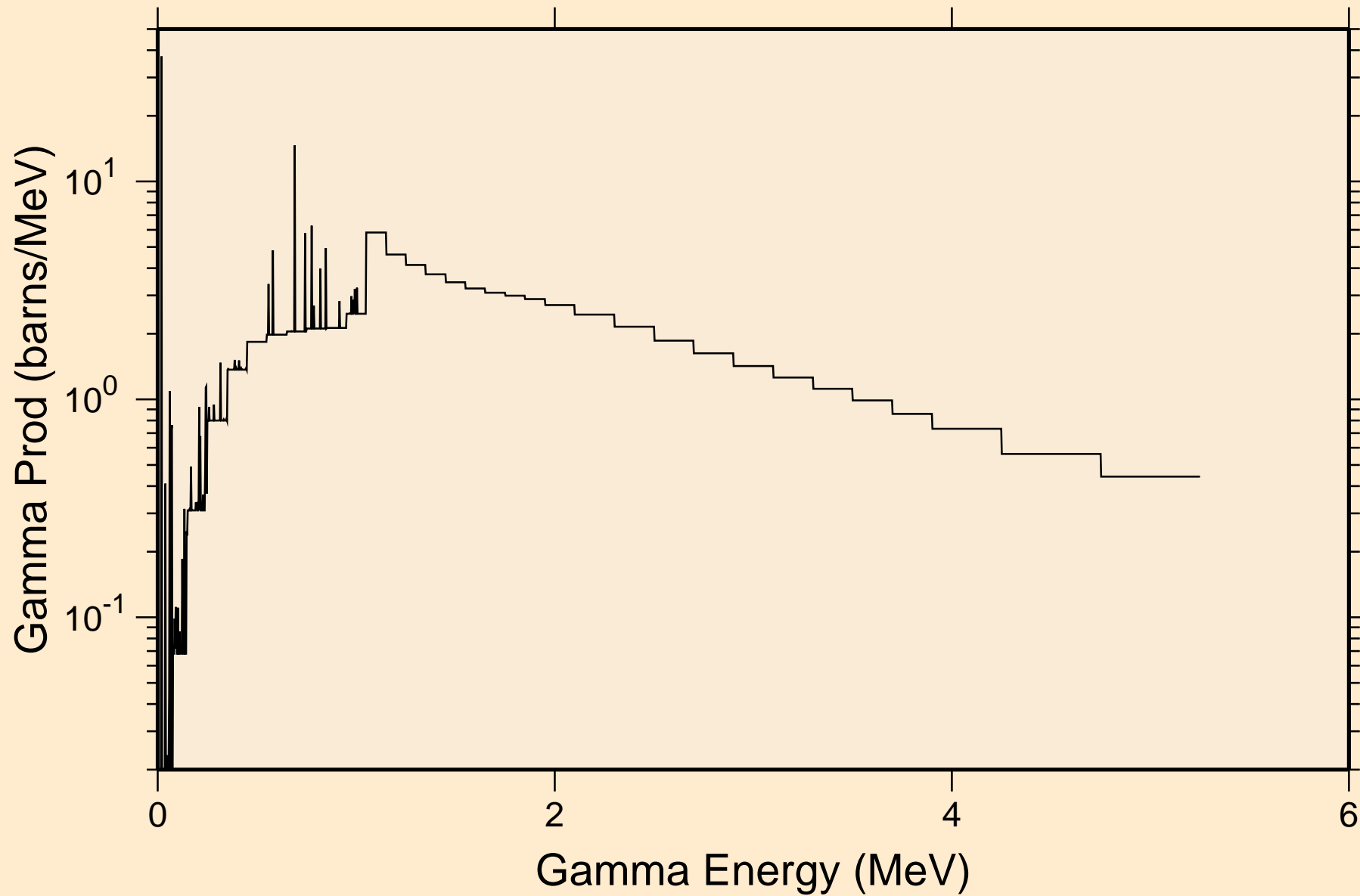

AG111 NEUTRON ACER TENDL-2024 LIBRARY; T=293.6K  
14 MeV photon spectrum

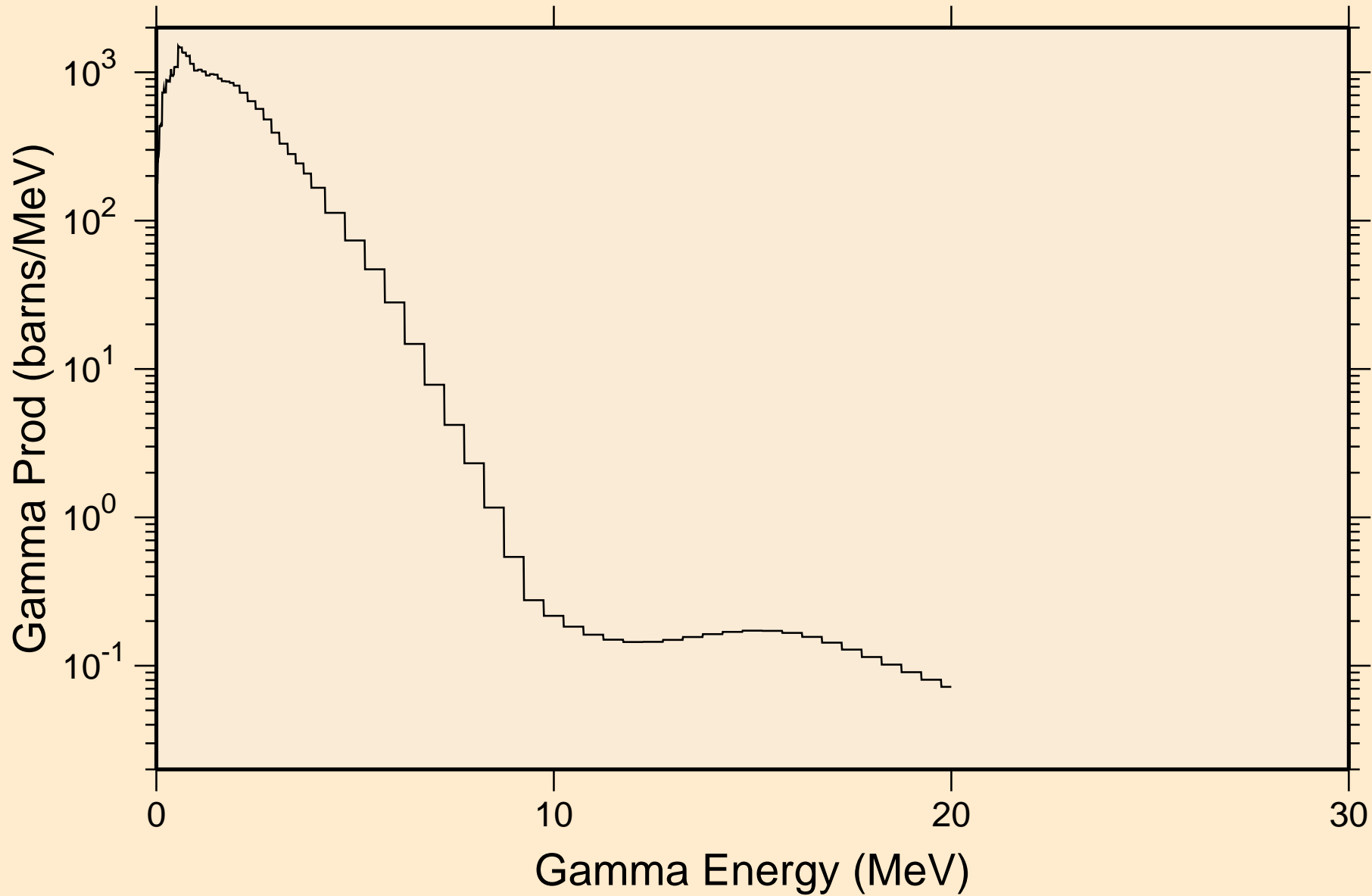

# AG111 NEUTRON ACER TENDL-2024 LIBRARY; T=293.6K

## Particle heating contributions

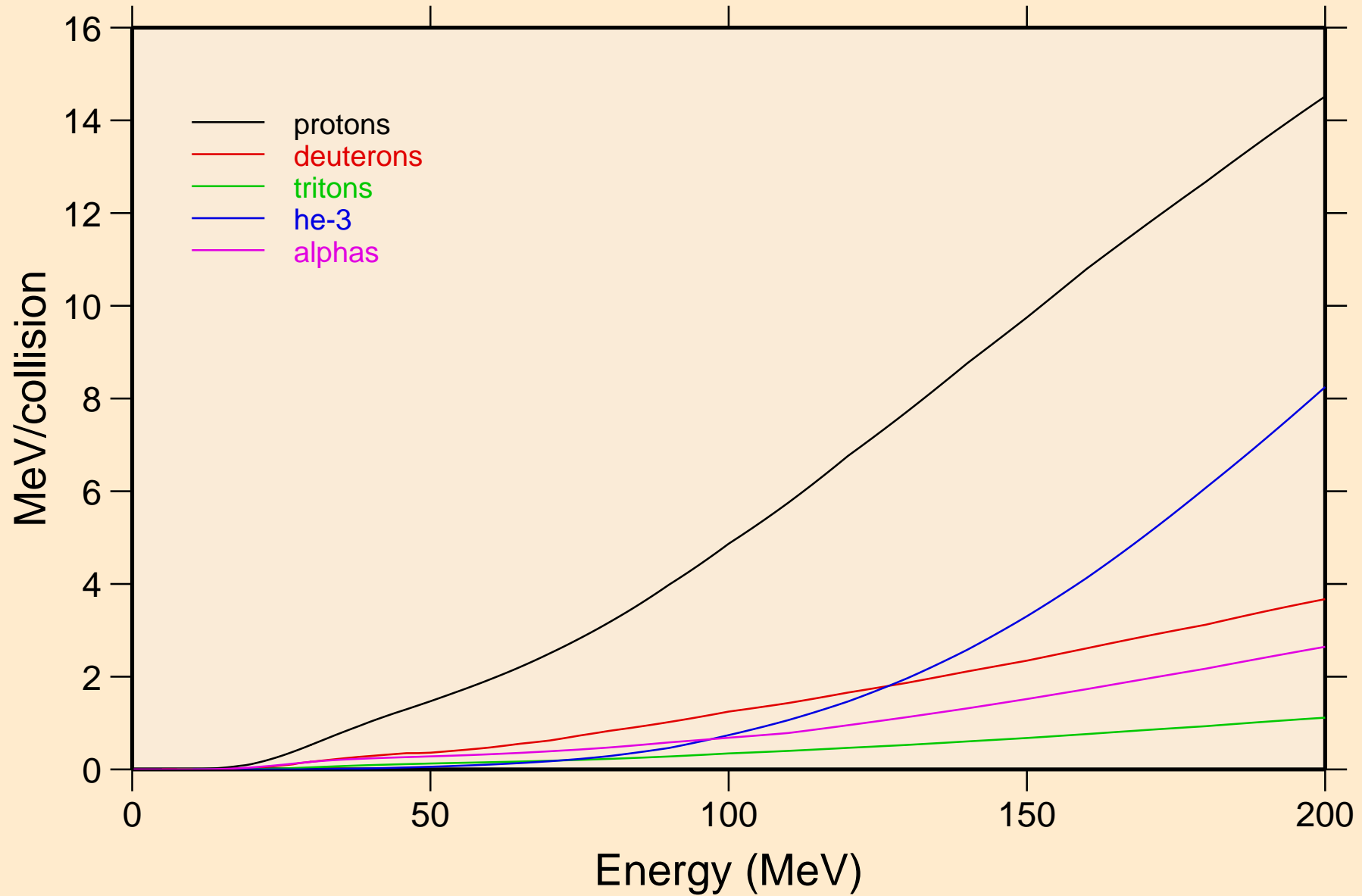

AG111 NEUTRON ACER TENDL-2024 LIBRARY; T=293.6K  
Recoil Heating

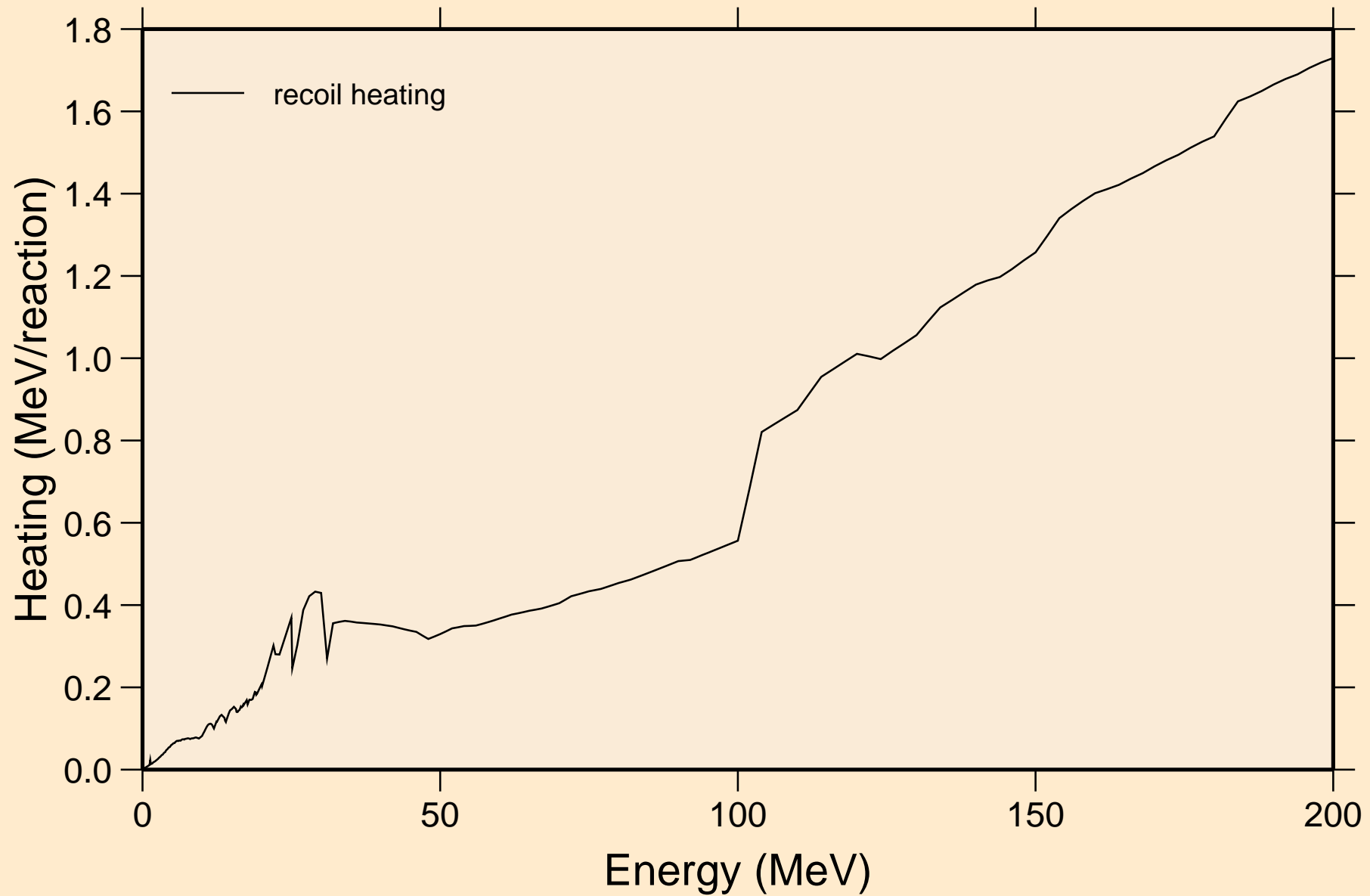

# AG111 NEUTRON ACER TENDL-2024 LIBRARY; T=293.6K

## Particle production cross sections

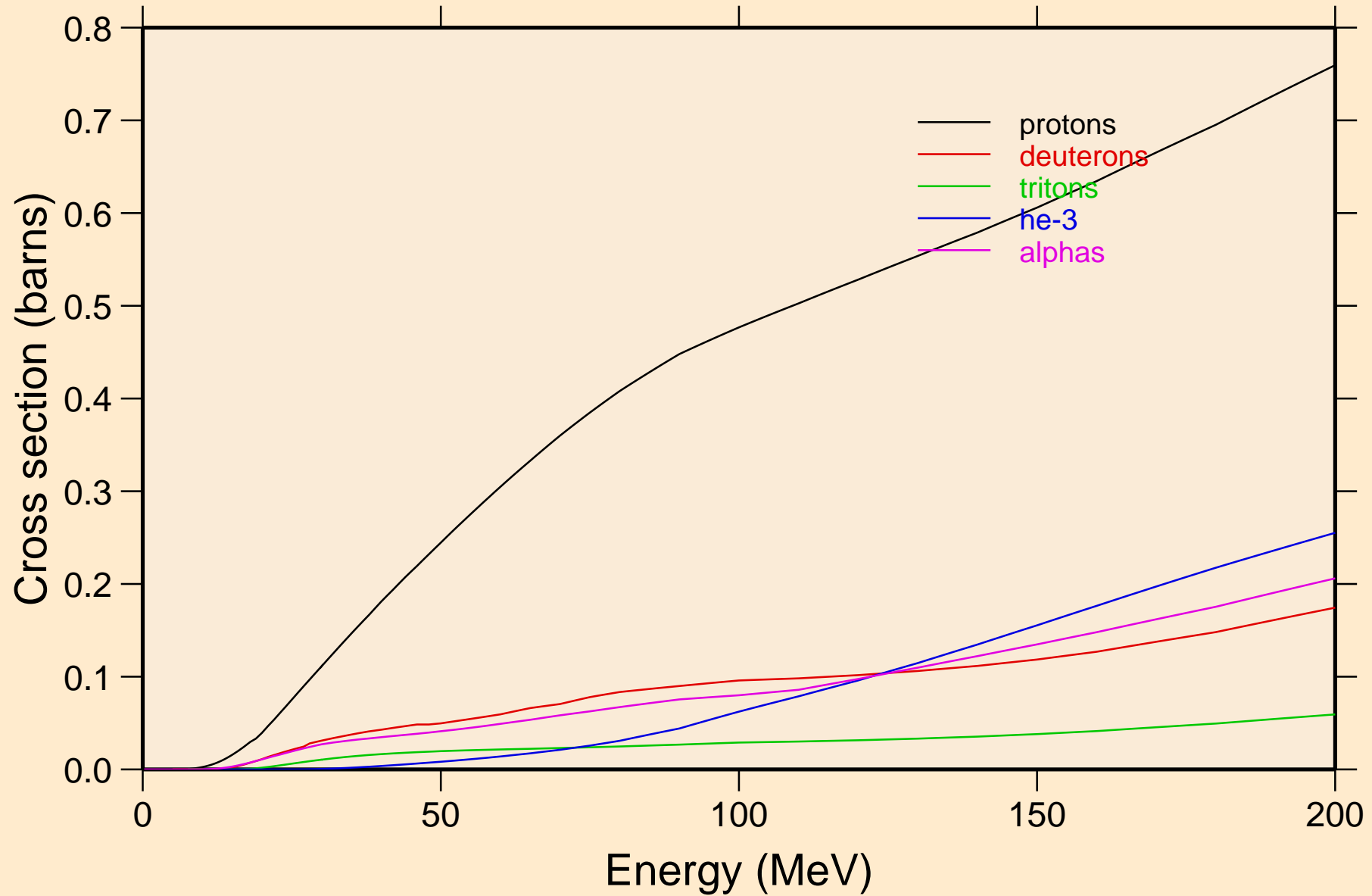

AG111 NEUTRON ACER TENDL-2024 LIBRARY; T=293.6K  
protons from (n,x)

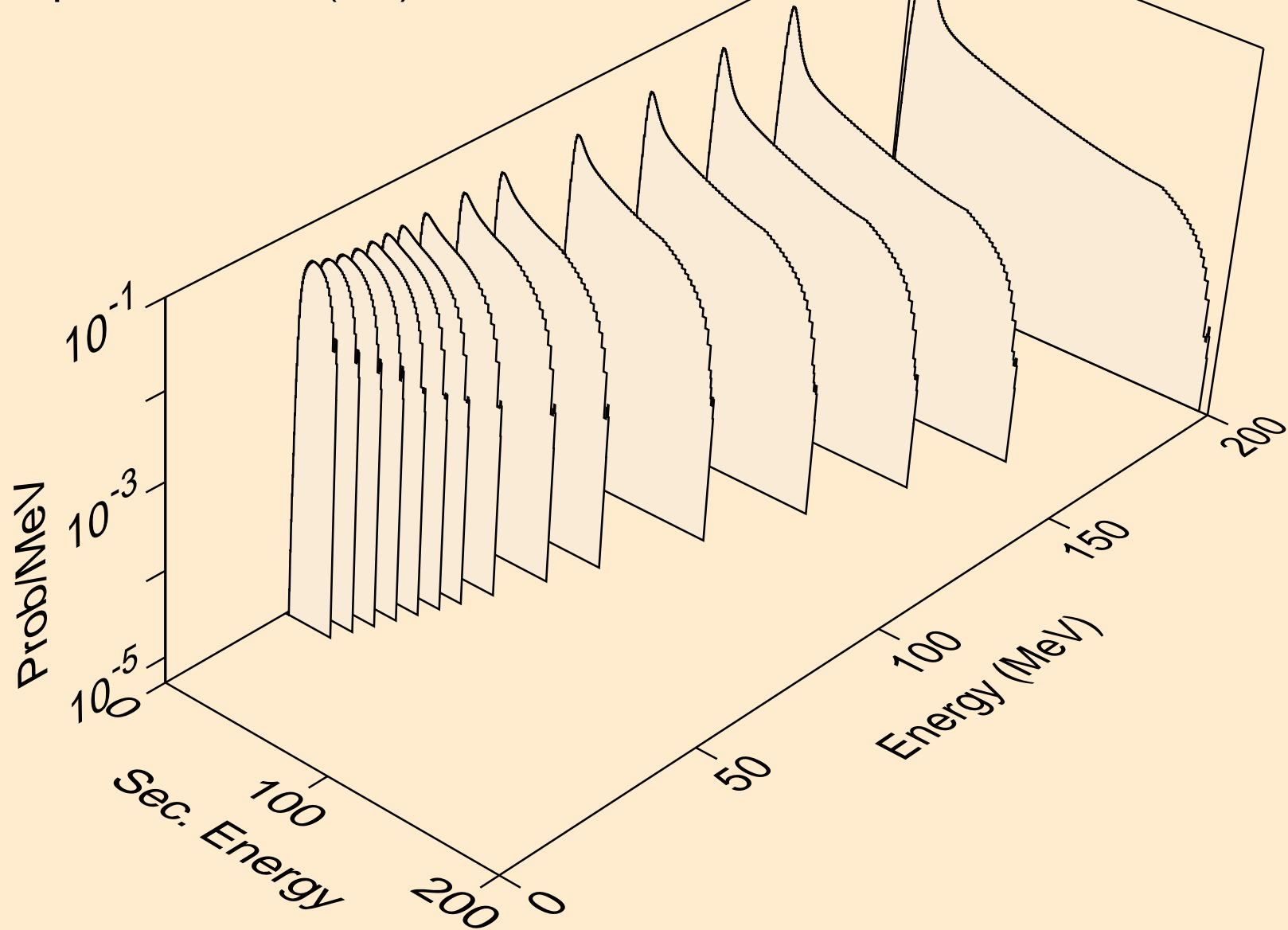

AG111 NEUTRON ACER TENDL-2024 LIBRARY; T=293.6K  
protons from (n,n\*)p

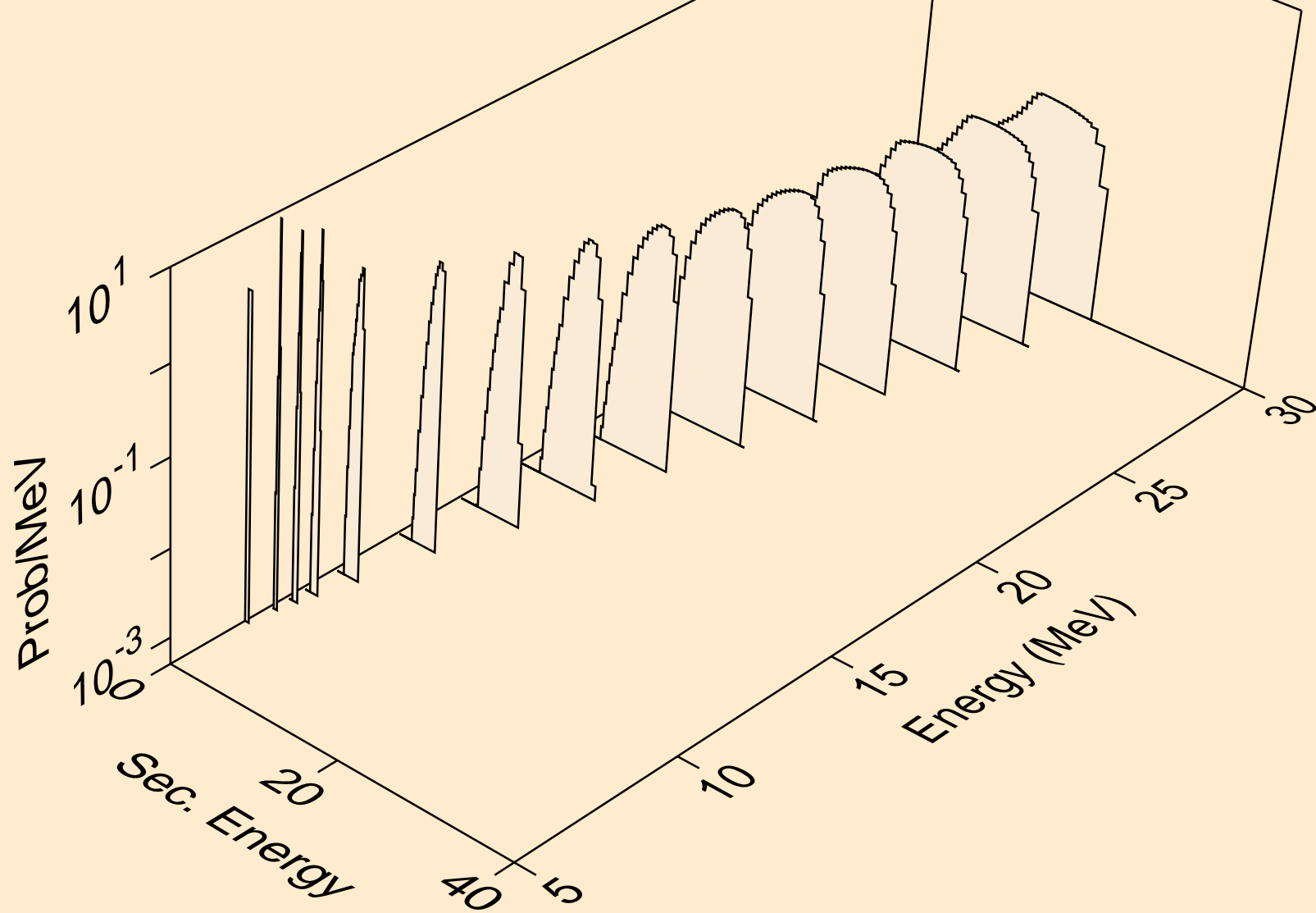

AG111 NEUTRON ACER TENDL-2024 LIBRARY; T=293.6K  
protons from (n,2np)

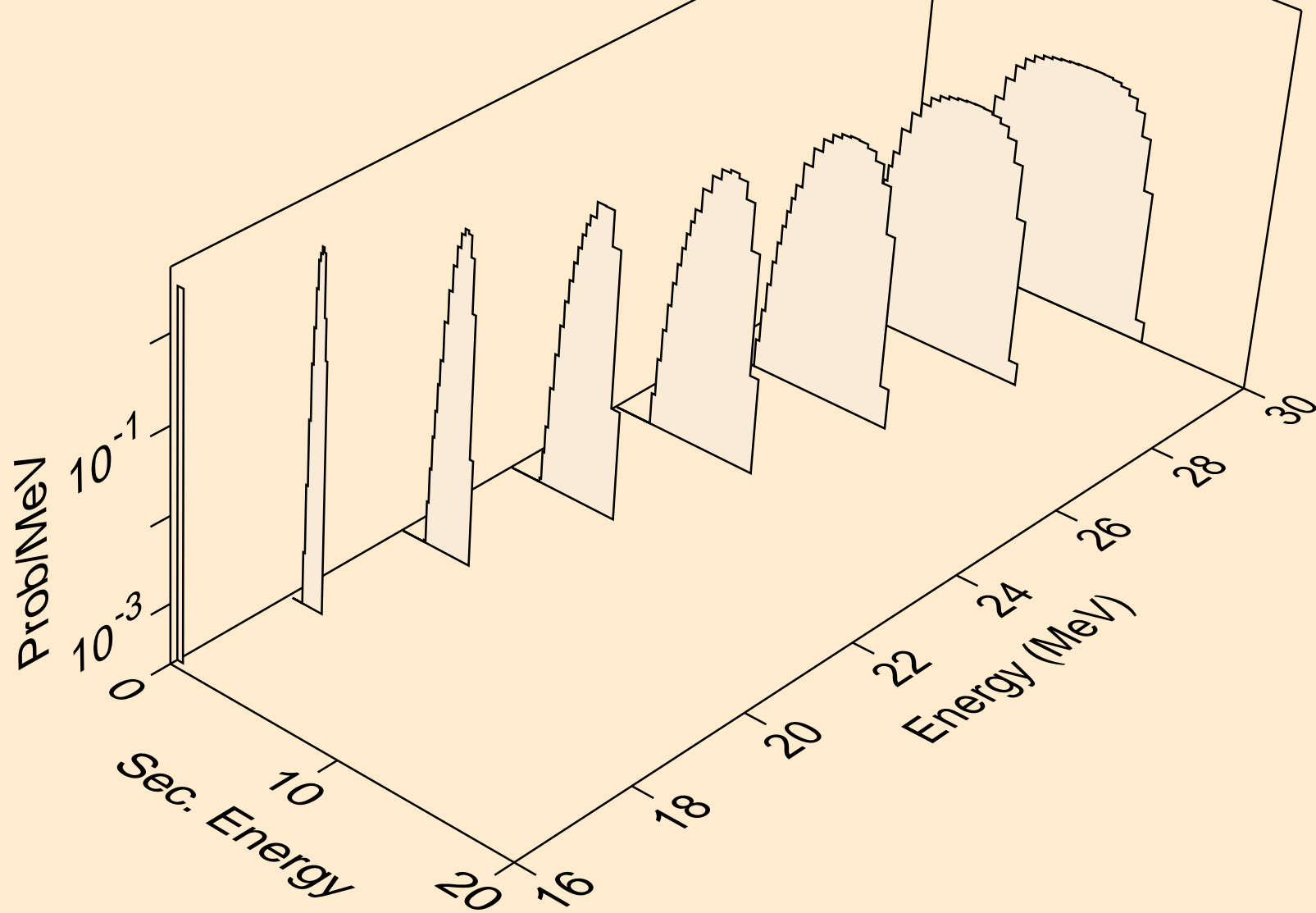

AG111 NEUTRON ACER TENDL-2024 LIBRARY; T=293.6K  
protons from (n,3np)

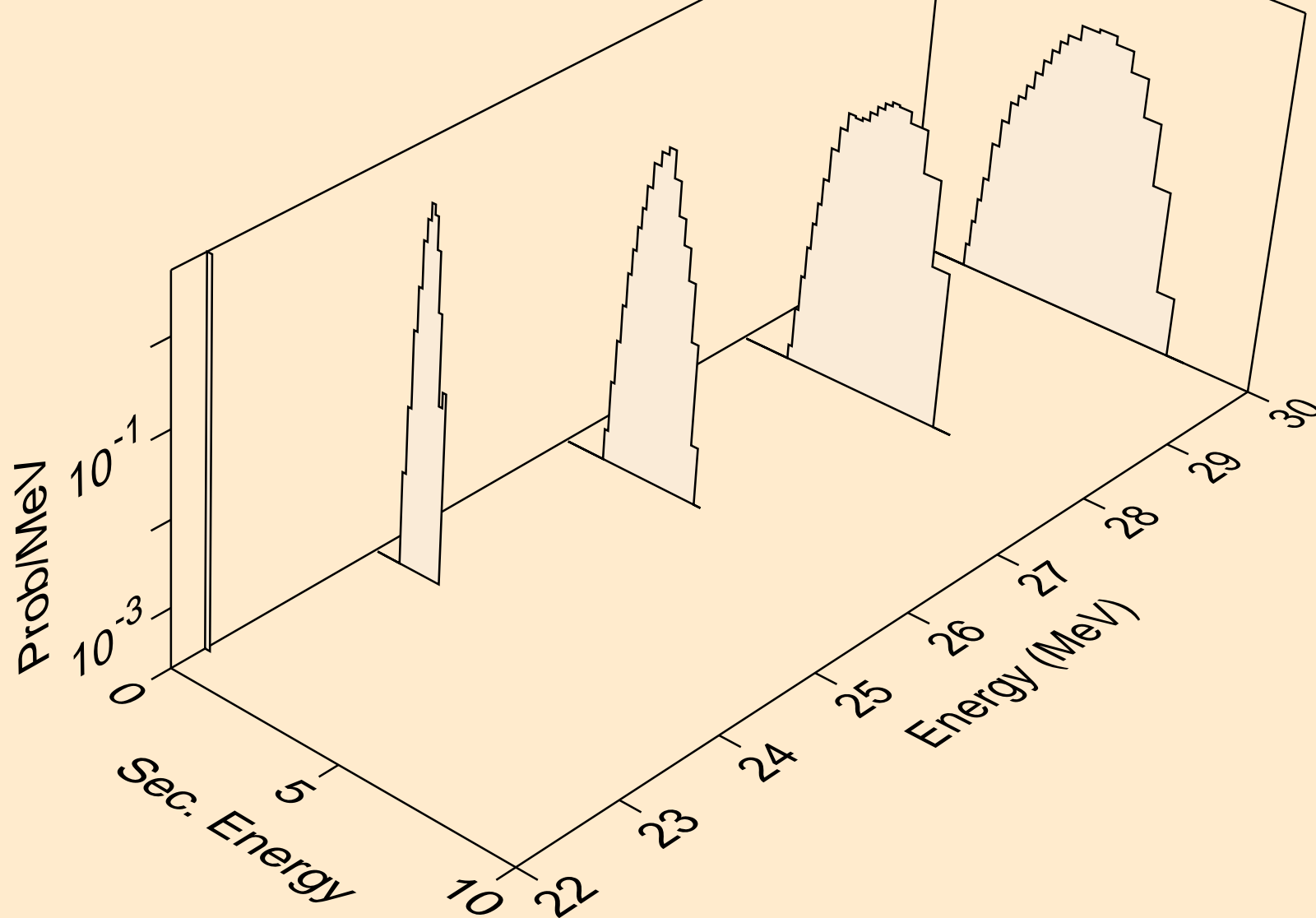

AG111 NEUTRON ACER TENDL-2024 LIBRARY; T=293.6K  
protons from (n,n2p)

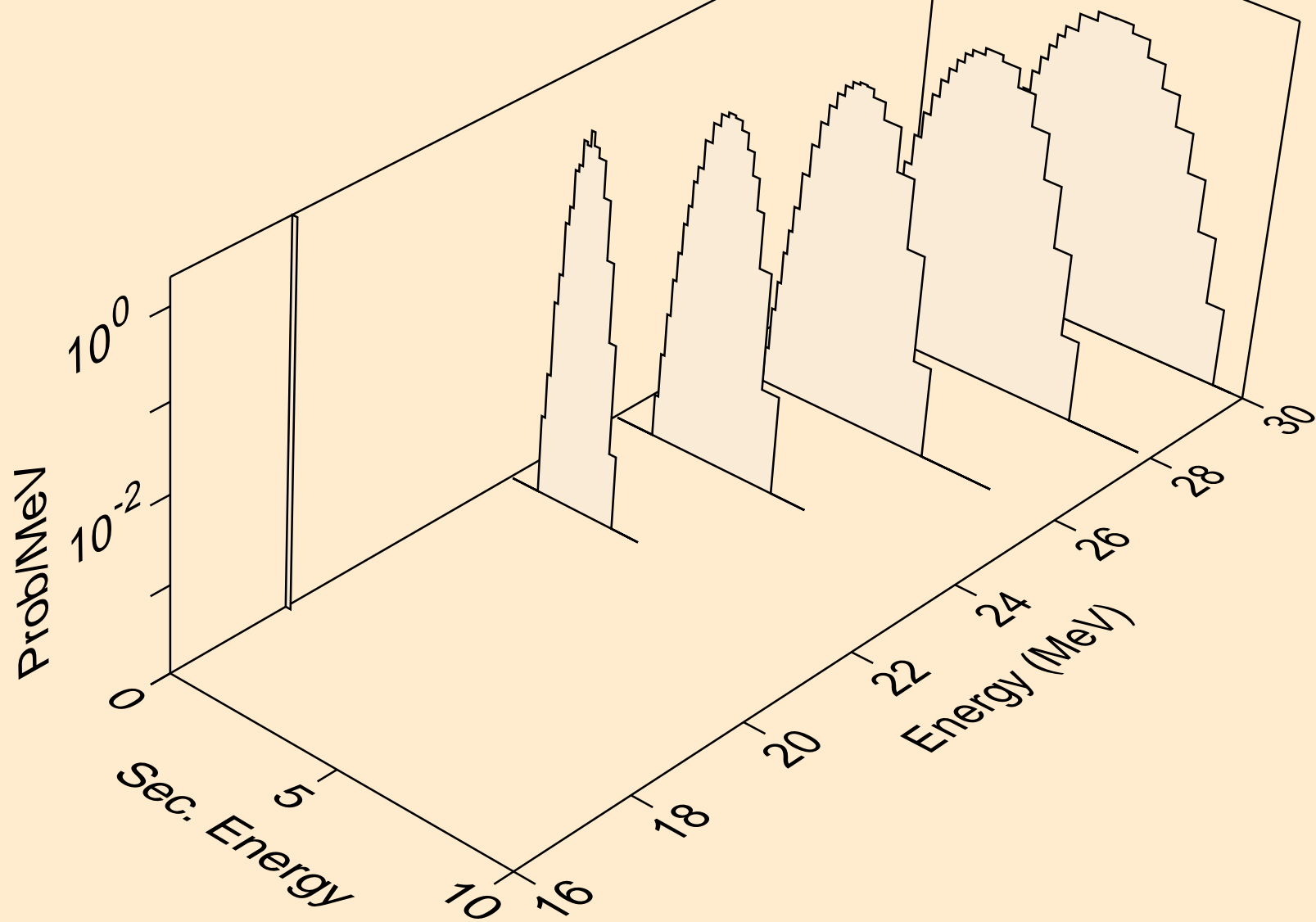

AG111 NEUTRON ACER TENDL-2024 LIBRARY; T=293.6K  
protons from (n,npa)

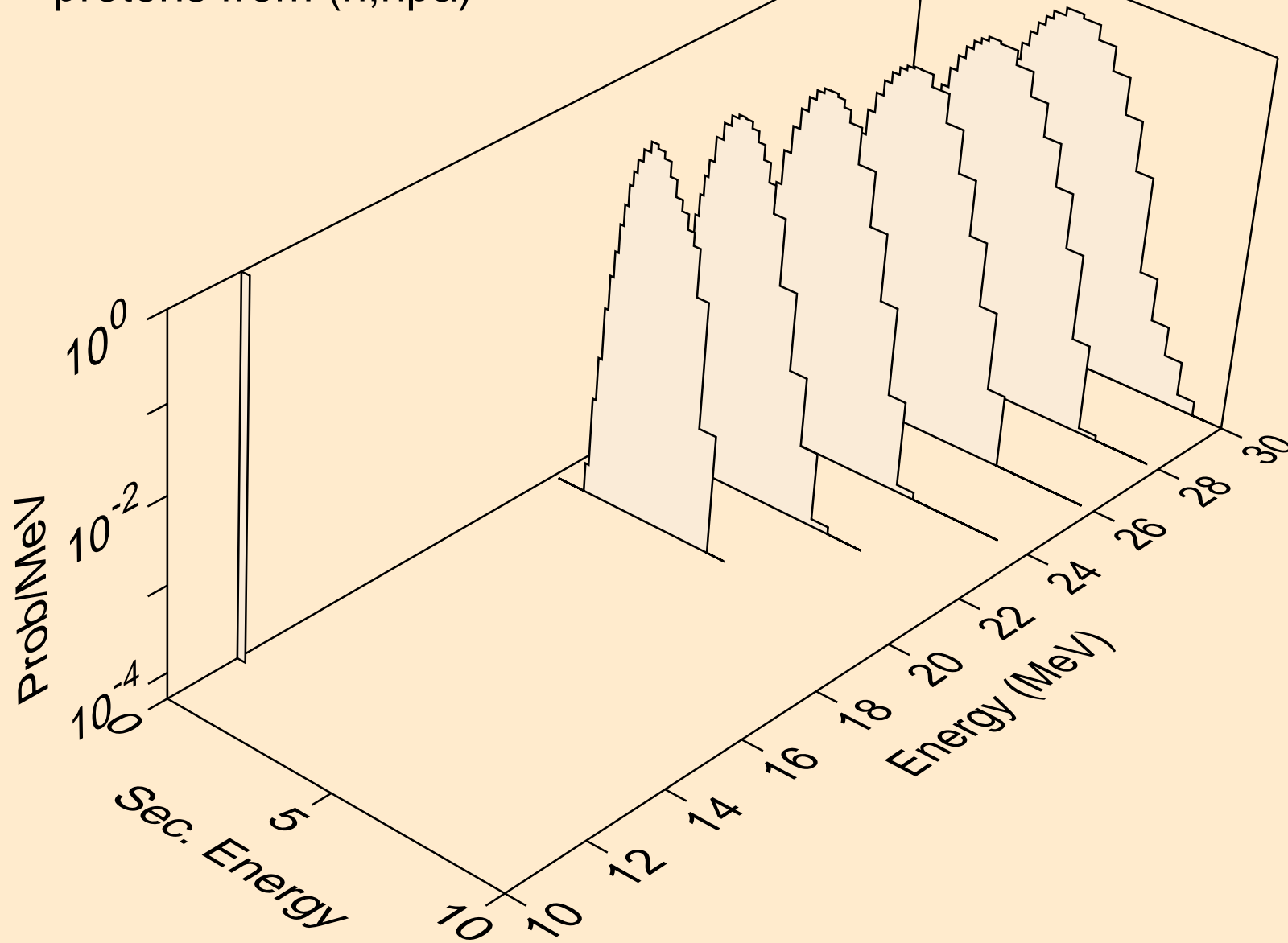

AG111 NEUTRON ACER TENDL-2024 LIBRARY; T=293.6K  
protons from (n,p)

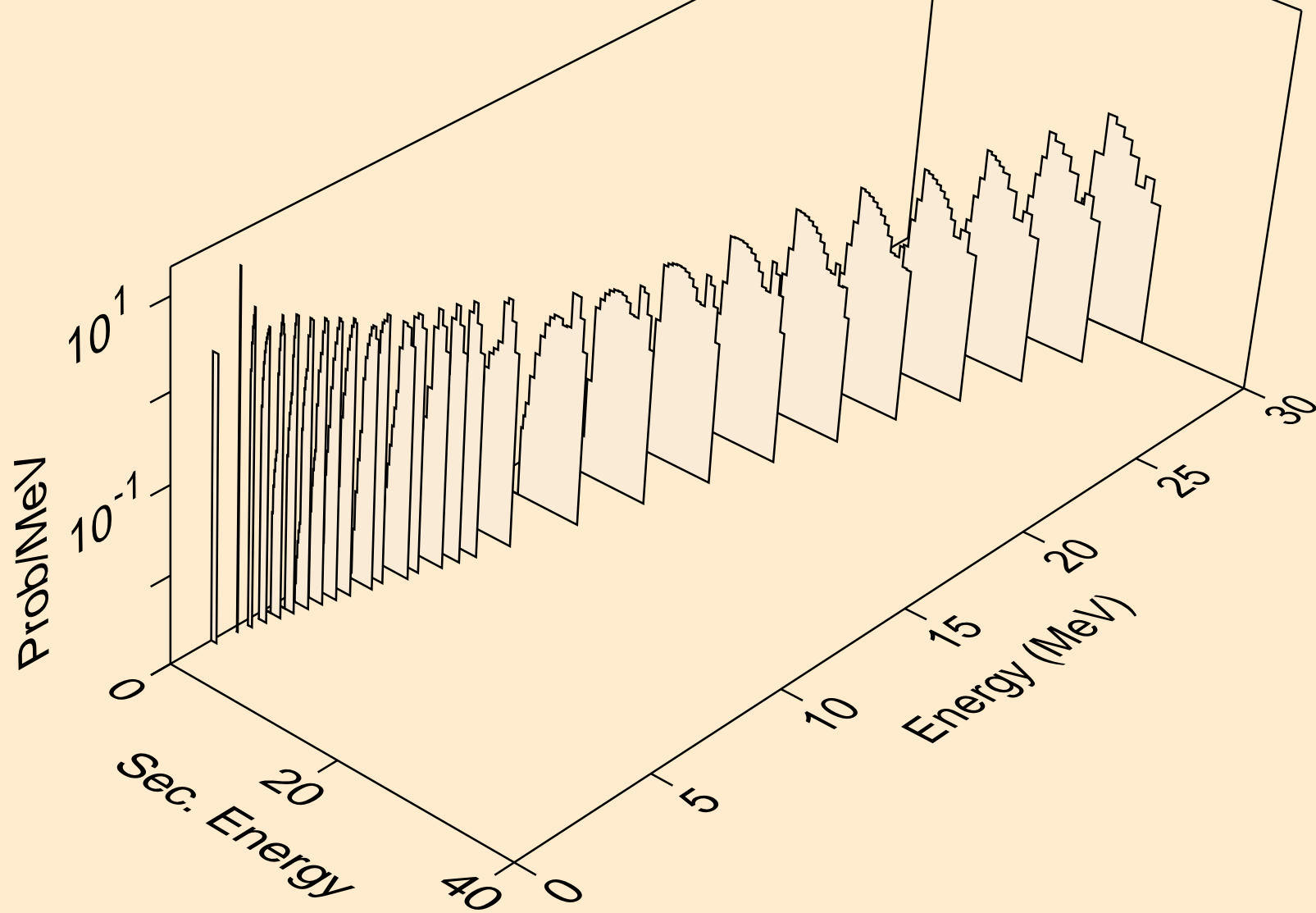

AG111 NEUTRON ACER TENDL-2024 LIBRARY; T=293.6K  
protons from (n,2p)

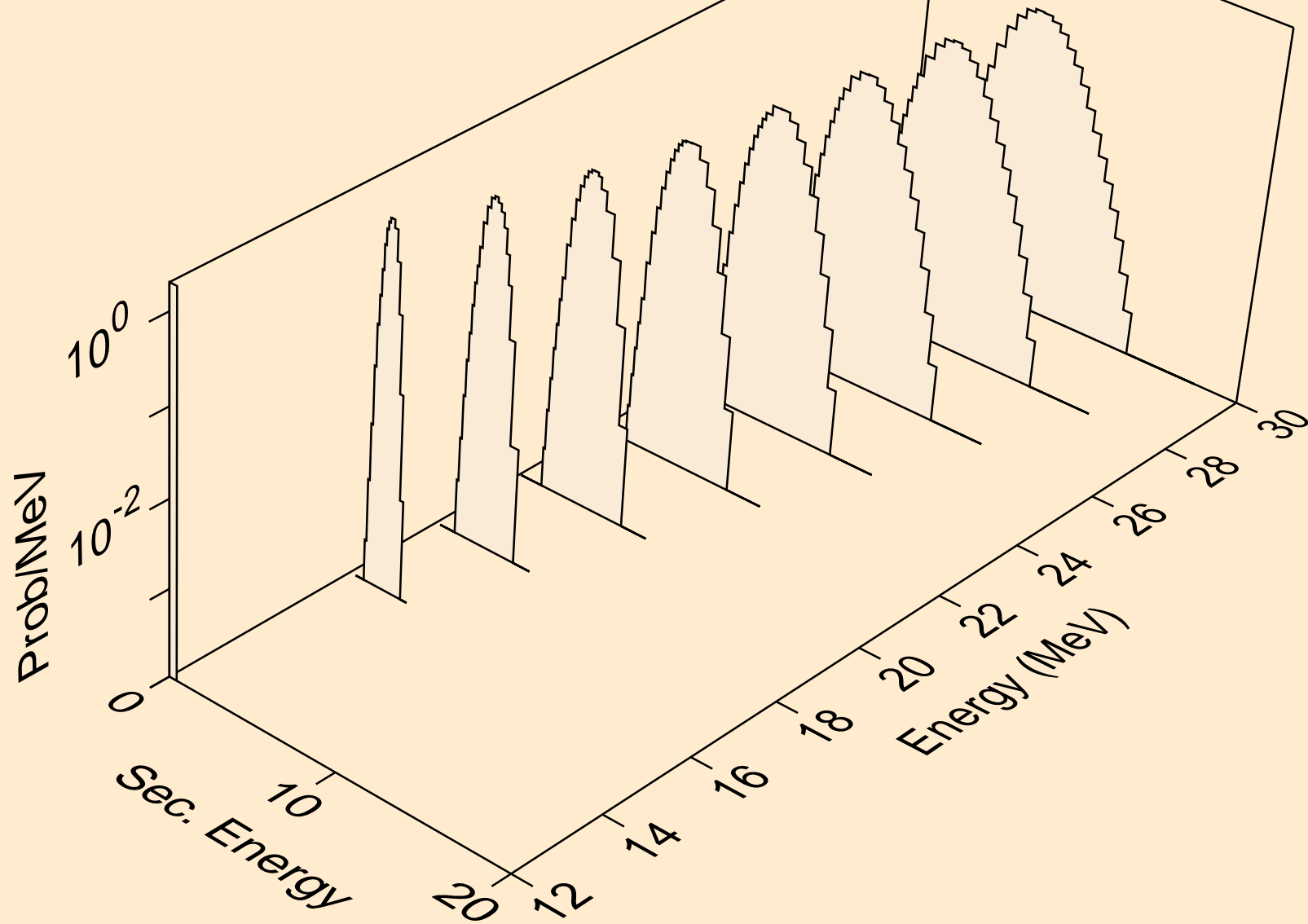

AG111 NEUTRON ACER TENDL-2024 LIBRARY; T=293.6K  
protons from (n,pa)

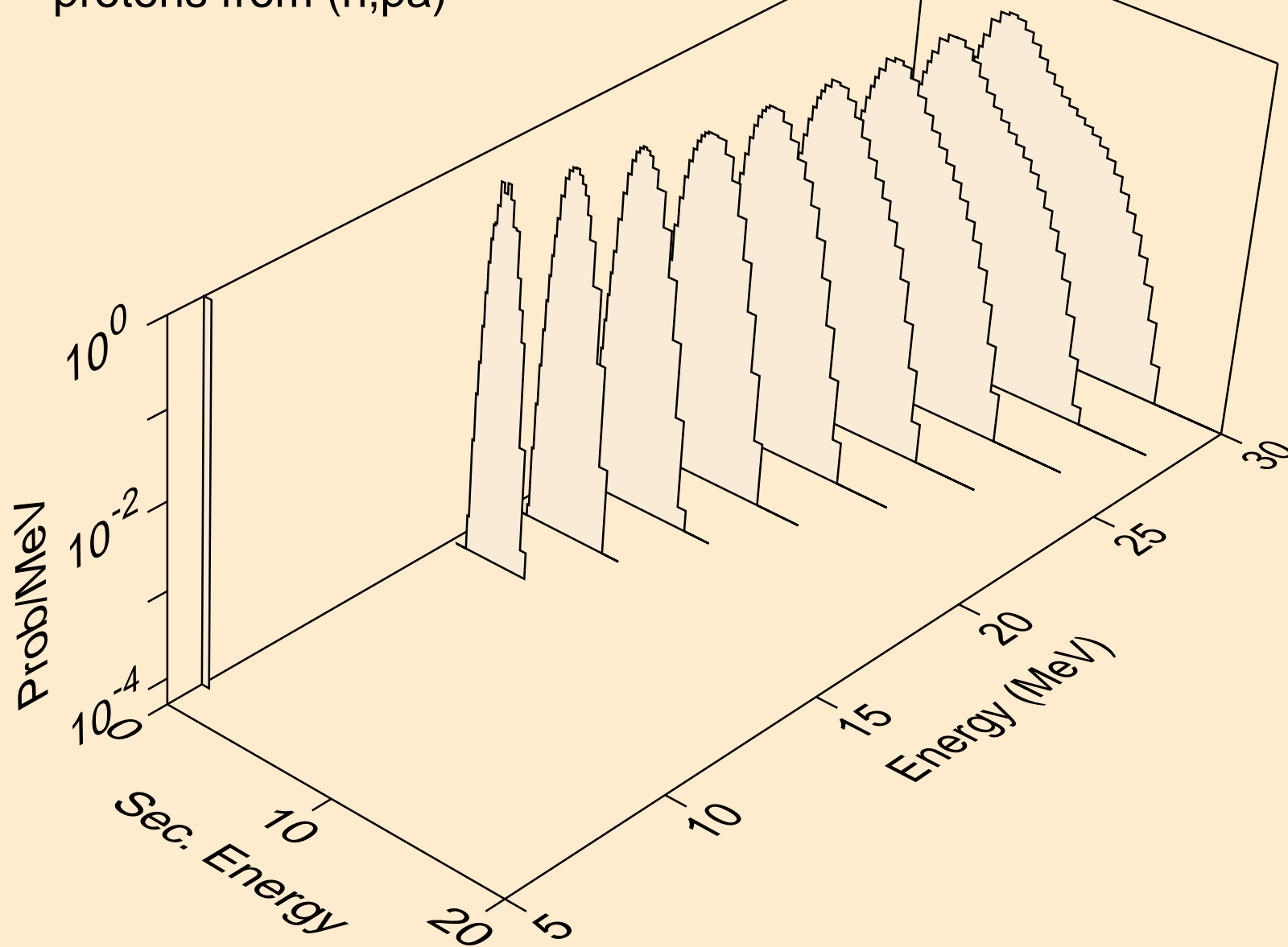

AG111 NEUTRON ACER TENDL-2024 LIBRARY; T=293.6K  
protons from (n,pd)

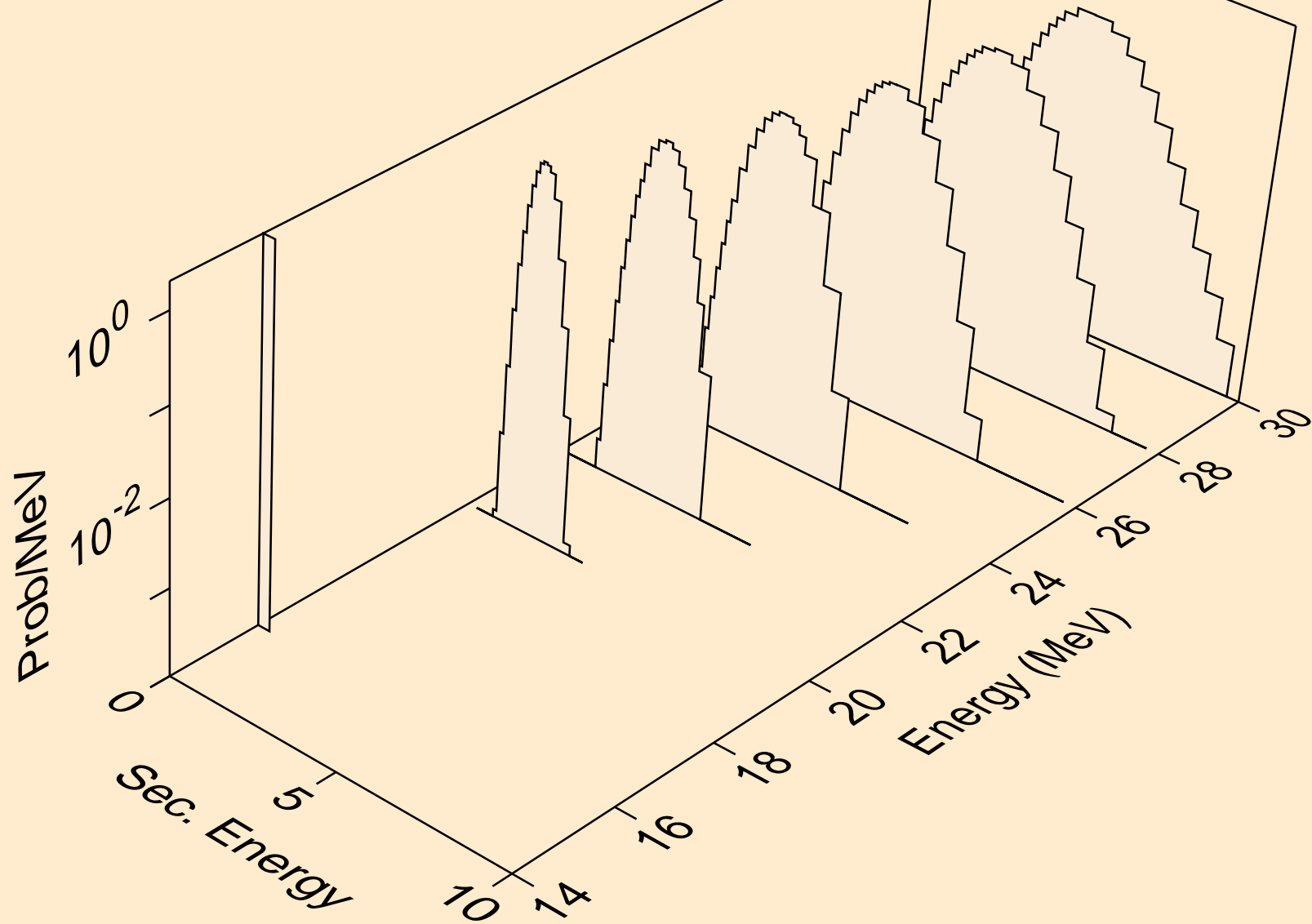

AG111 NEUTRON ACER TENDL-2024 LIBRARY; T=293.6K  
protons from (n,pt)

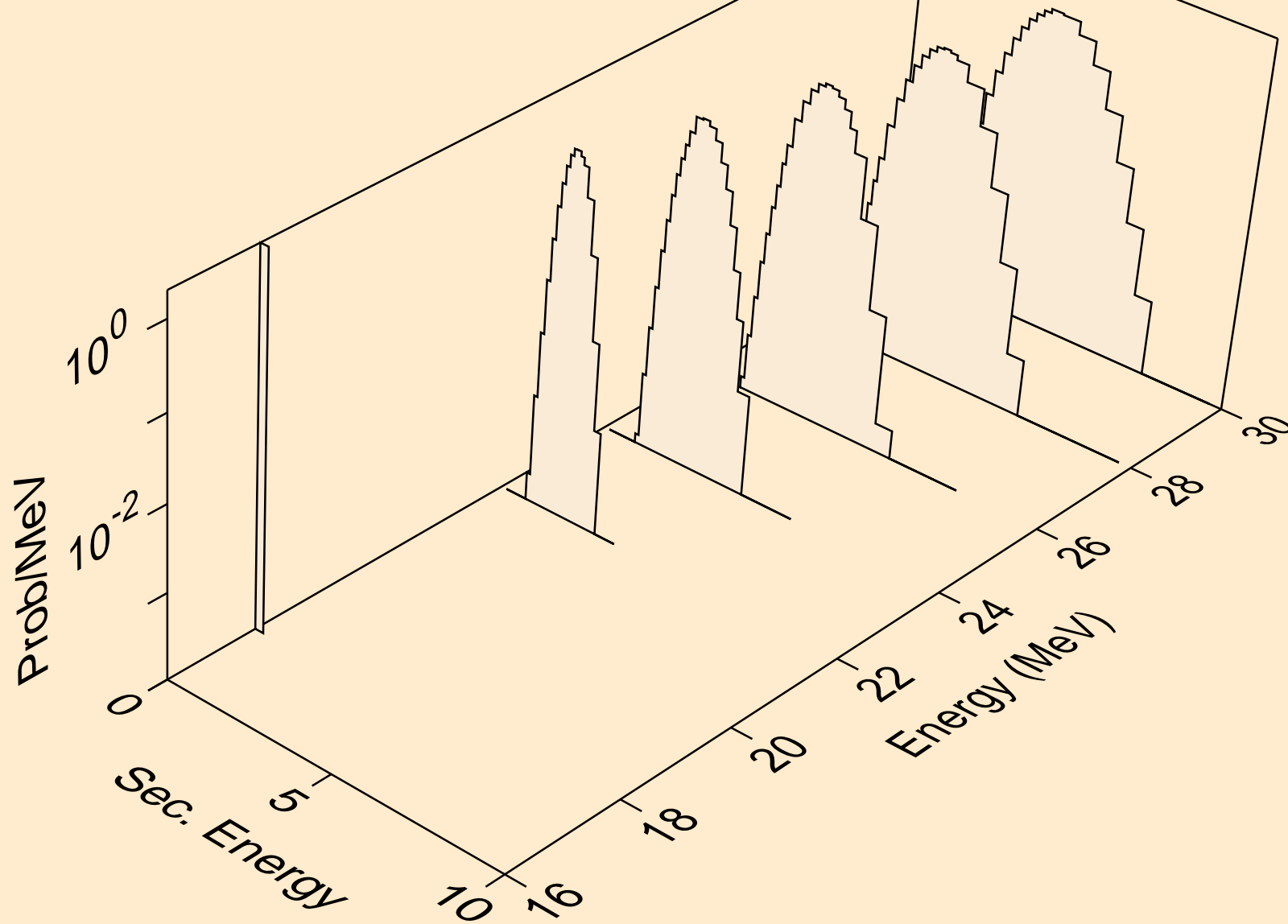

AG111 NEUTRON ACER TENDL-2024 LIBRARY; T=293.6K  
deuterons from (n,x)

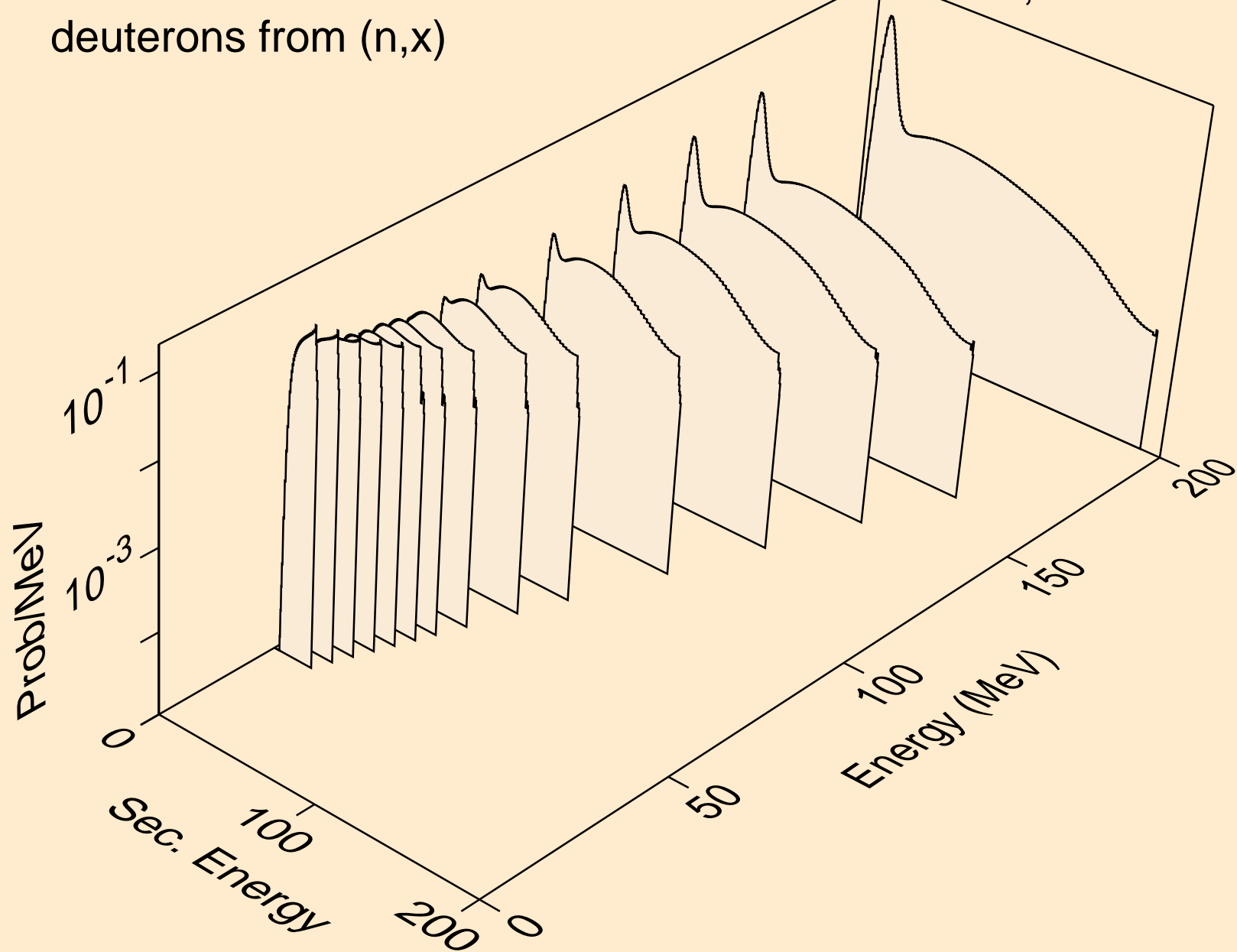

AG111 NEUTRON ACER TENDL-2024 LIBRARY; T=293.6K  
deuterons from (n,2nd)

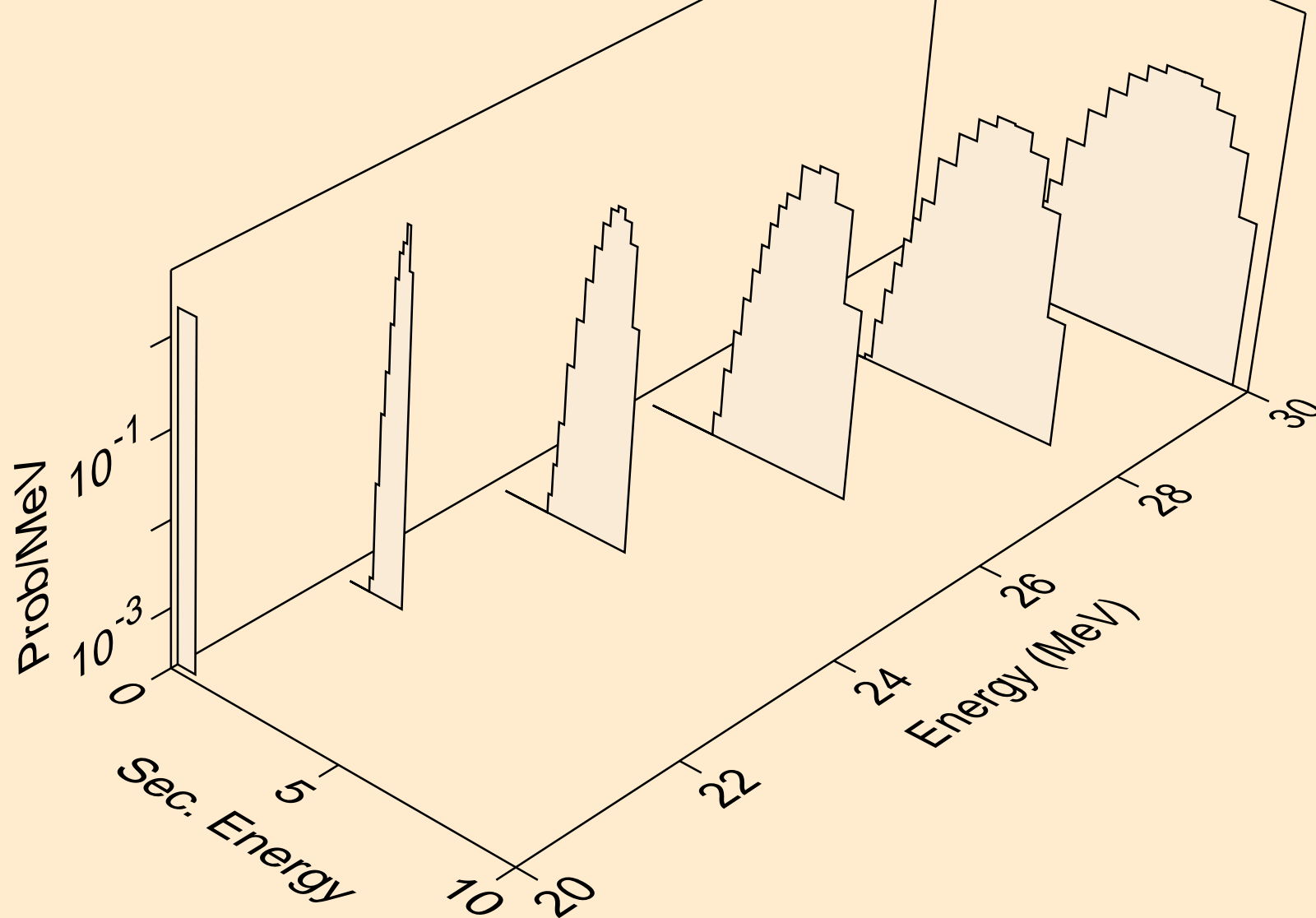

AG111 NEUTRON ACER TENDL-2024 LIBRARY; T=293.6K  
deuterons from (n,n\*)d

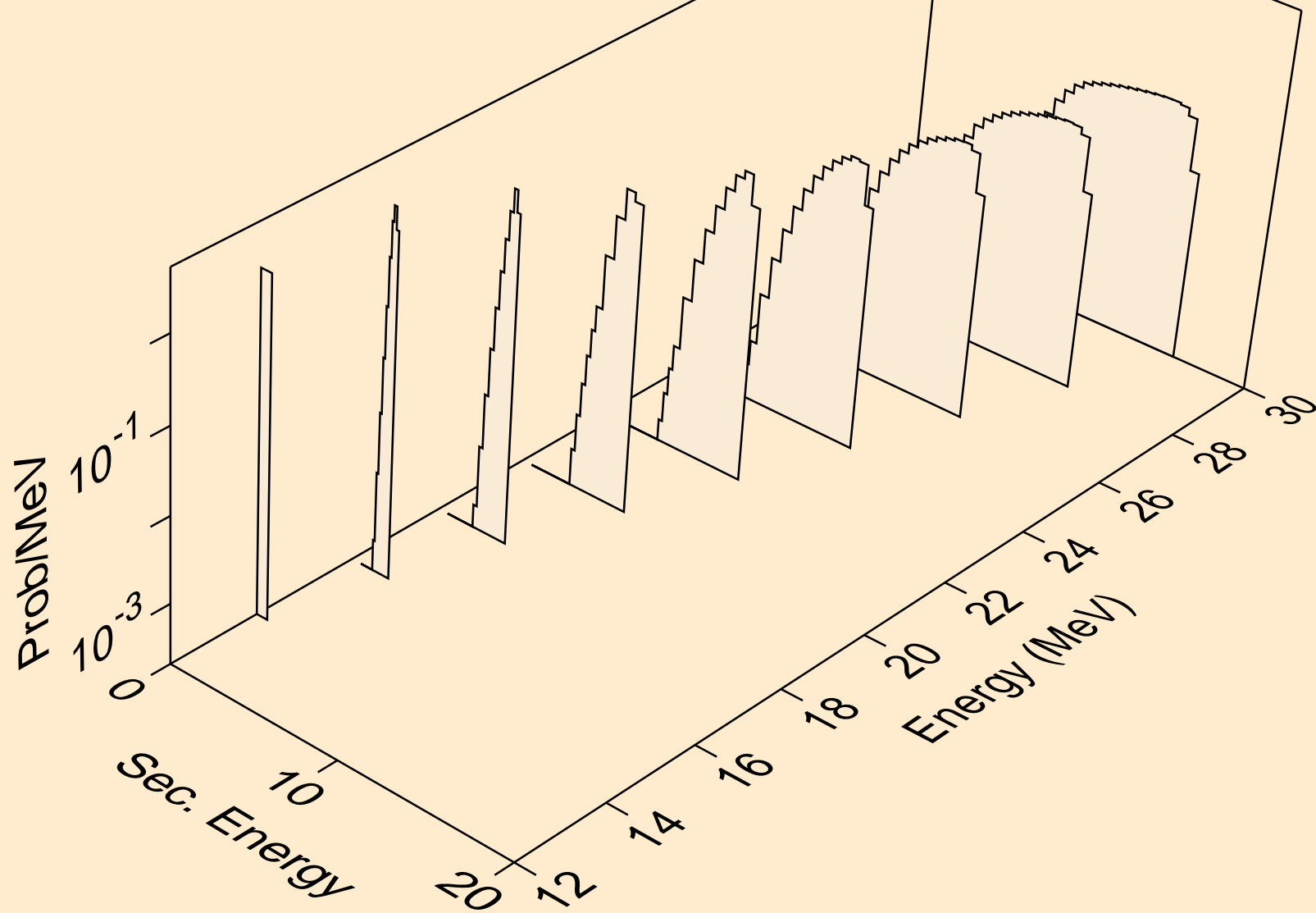

AG111 NEUTRON ACER TENDL-2024 LIBRARY; T=293.6K  
deuterons from (n,d)

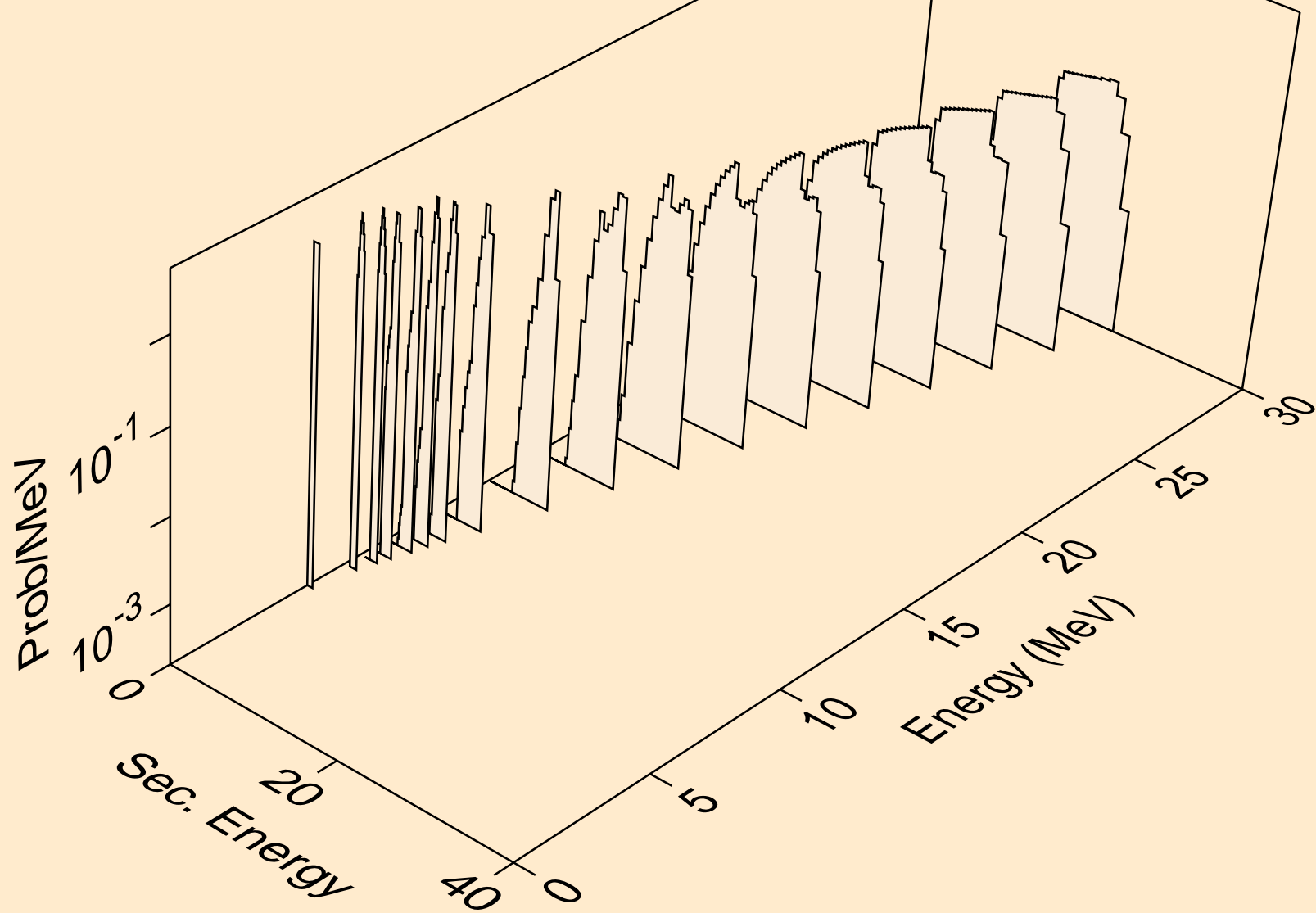

AG111 NEUTRON ACER TENDL-2024 LIBRARY; T=293.6K  
deuterons from (n,pd)

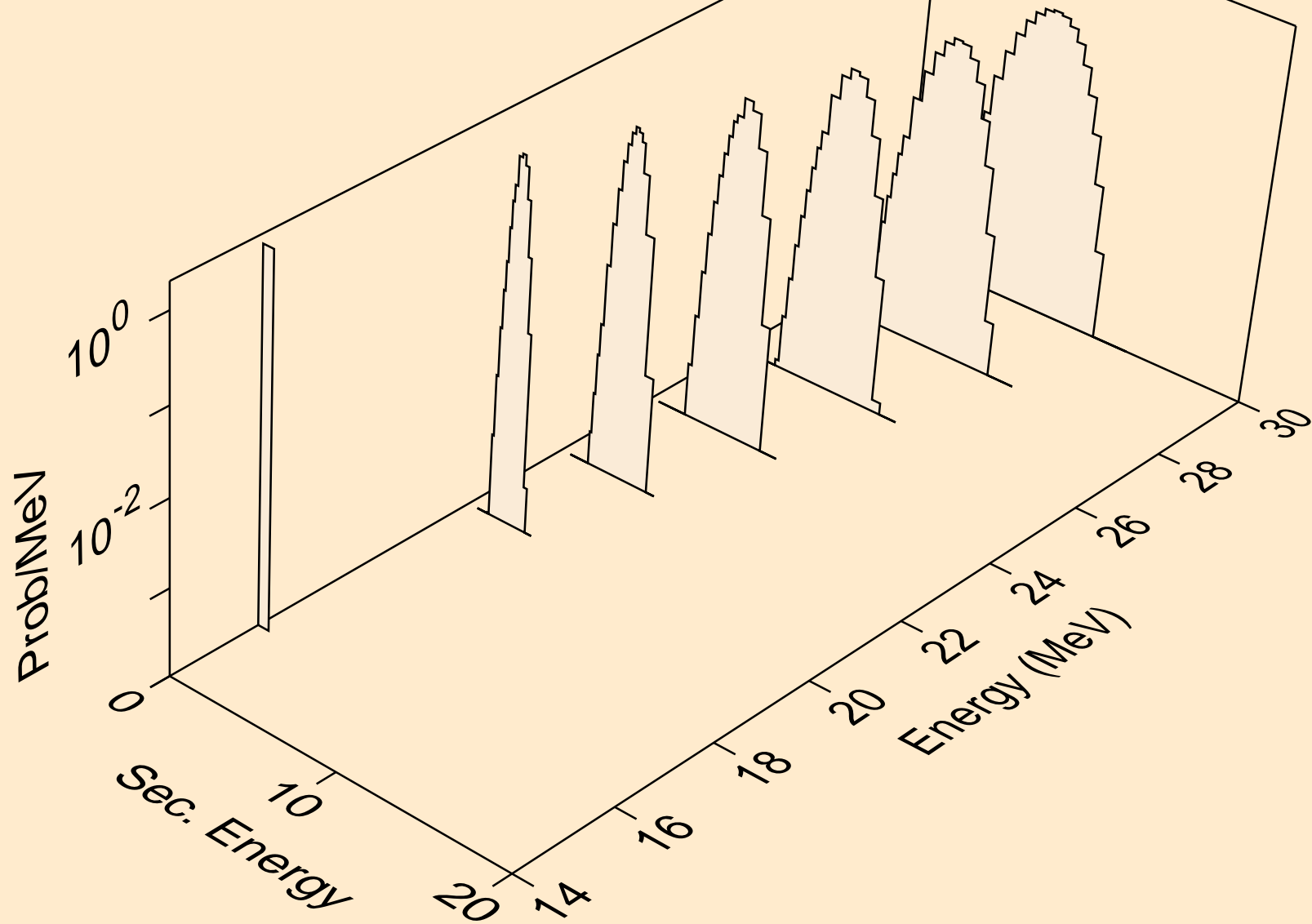

AG111 NEUTRON ACER TENDL-2024 LIBRARY; T=293.6K  
deuterons from (n,da)

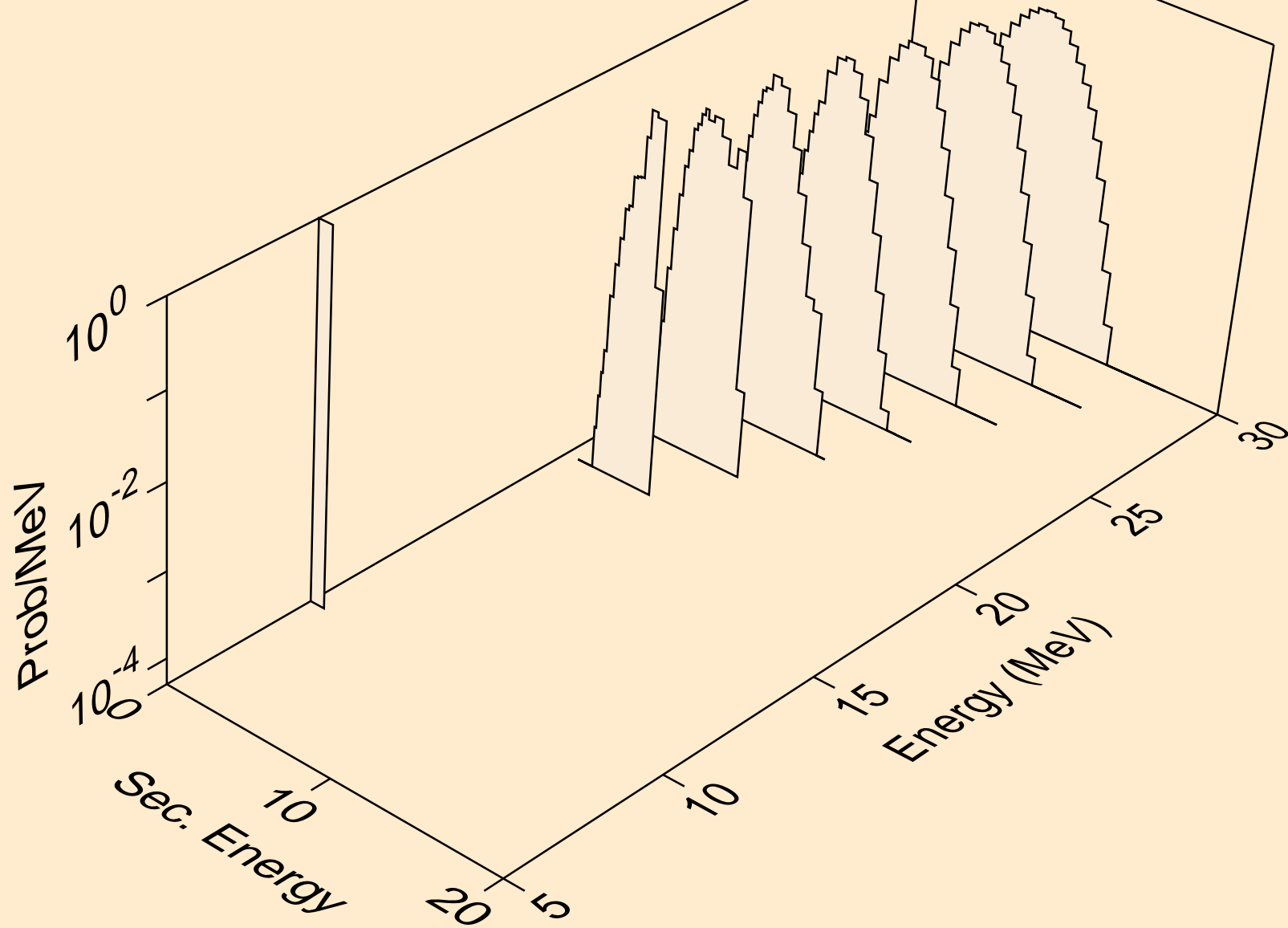

AG111 NEUTRON ACER TENDL-2024 LIBRARY; T=293.6K  
tritons from (n,x)

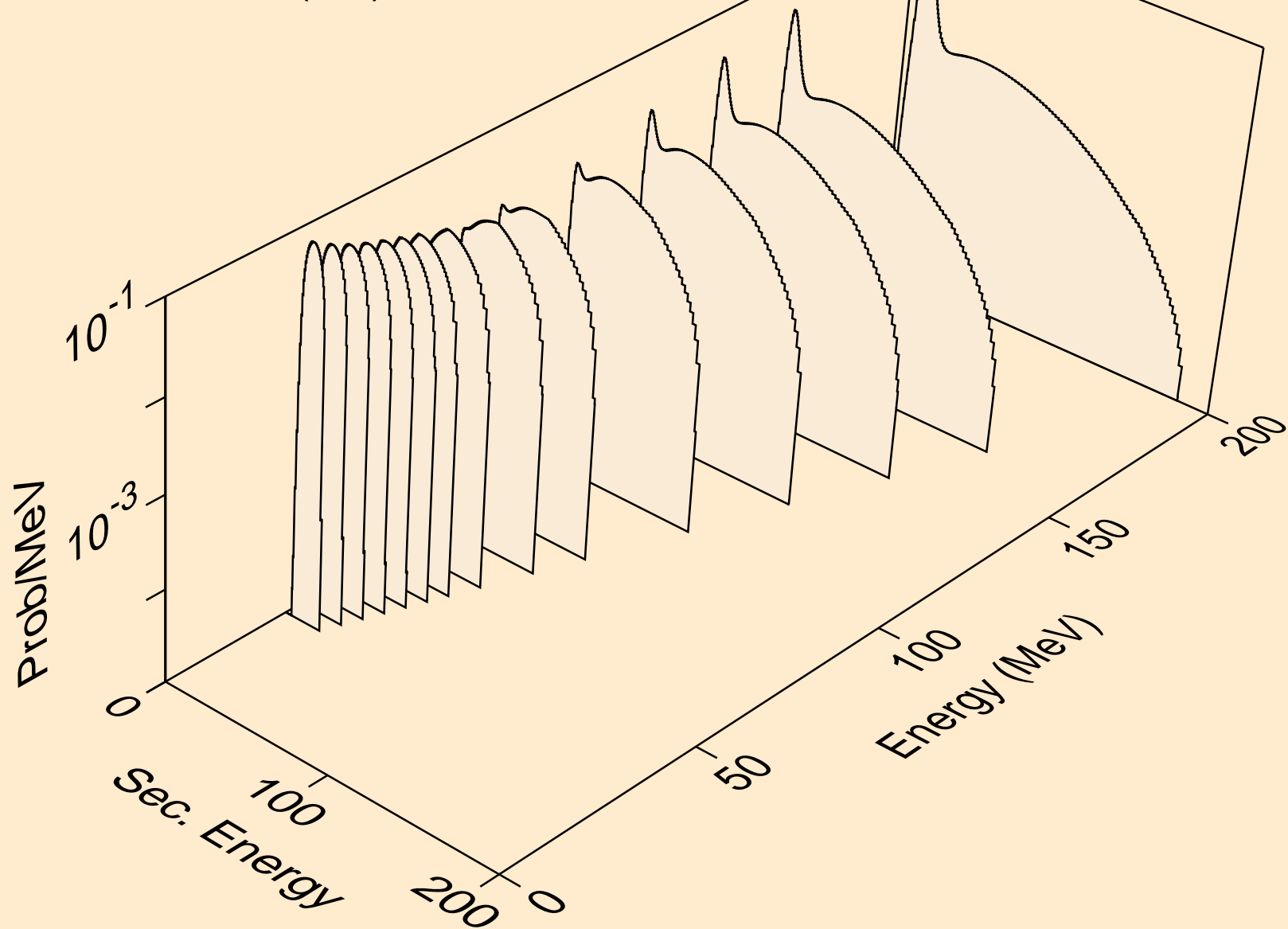

AG111 NEUTRON ACER TENDL-2024 LIBRARY; T=293.6K  
tritons from (n,n\*)t

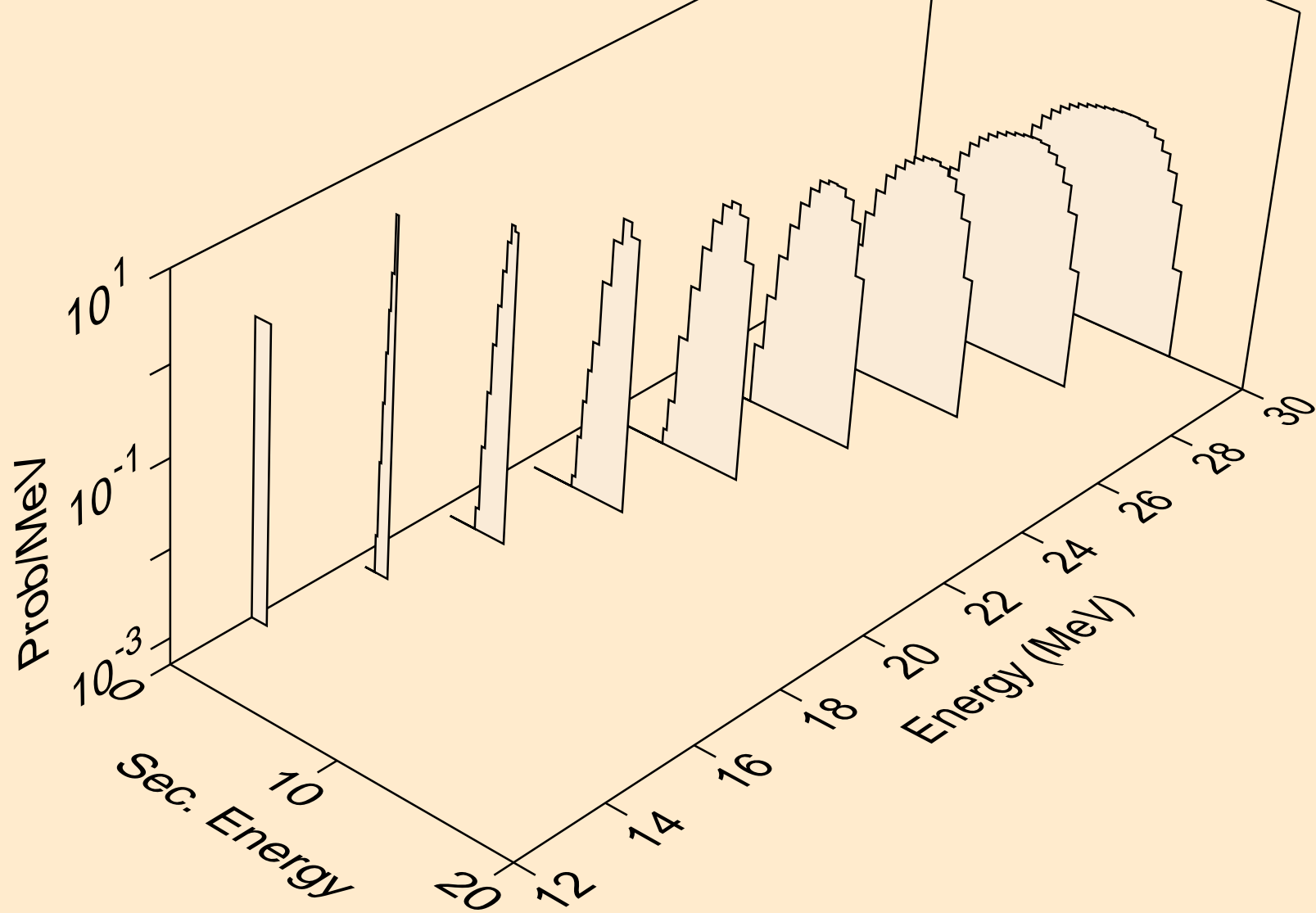

AG111 NEUTRON ACER TENDL-2024 LIBRARY; T=293.6K  
tritons from (n,t)

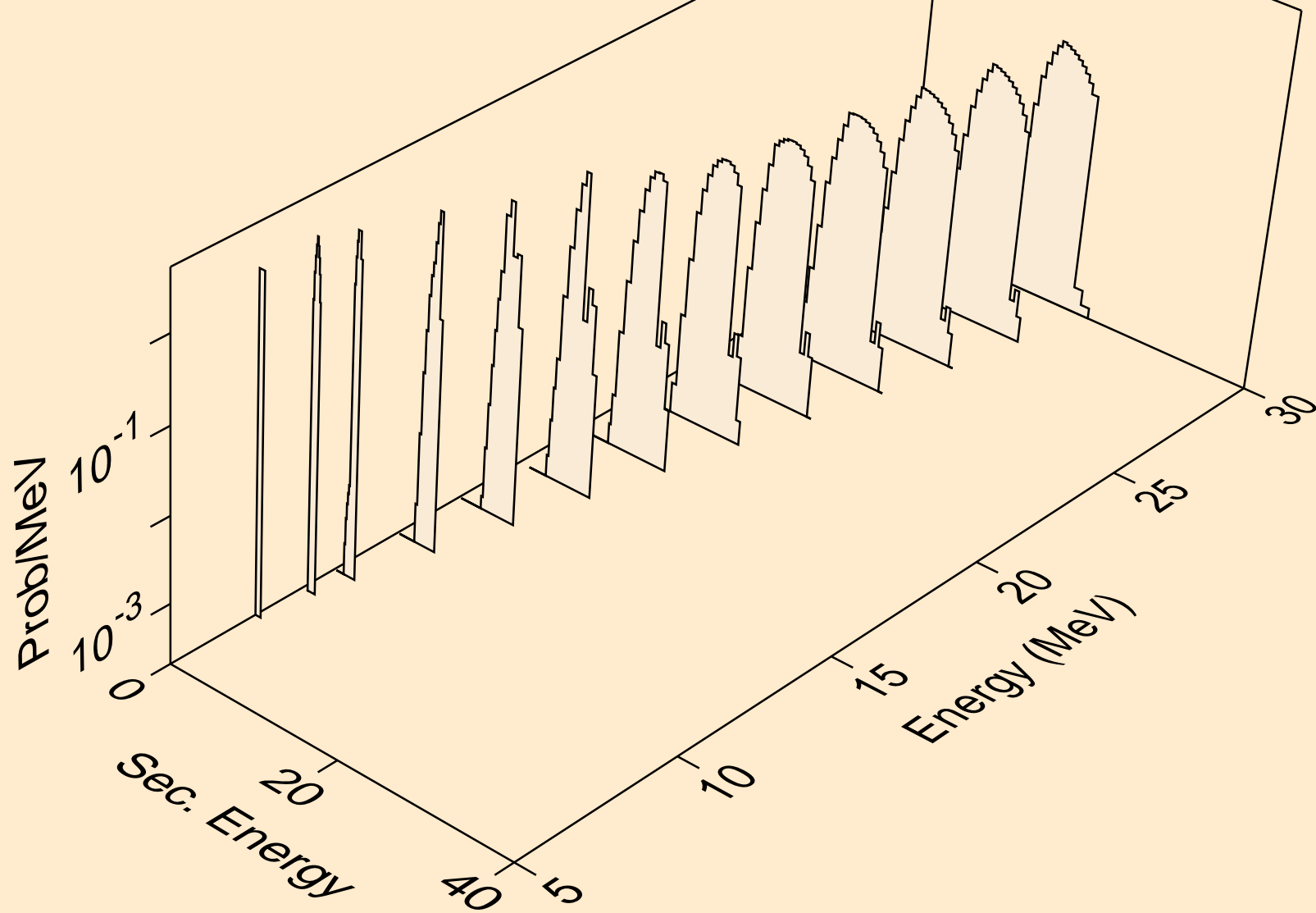

AG111 NEUTRON ACER TENDL-2024 LIBRARY; T=293.6K  
tritons from (n,pt)

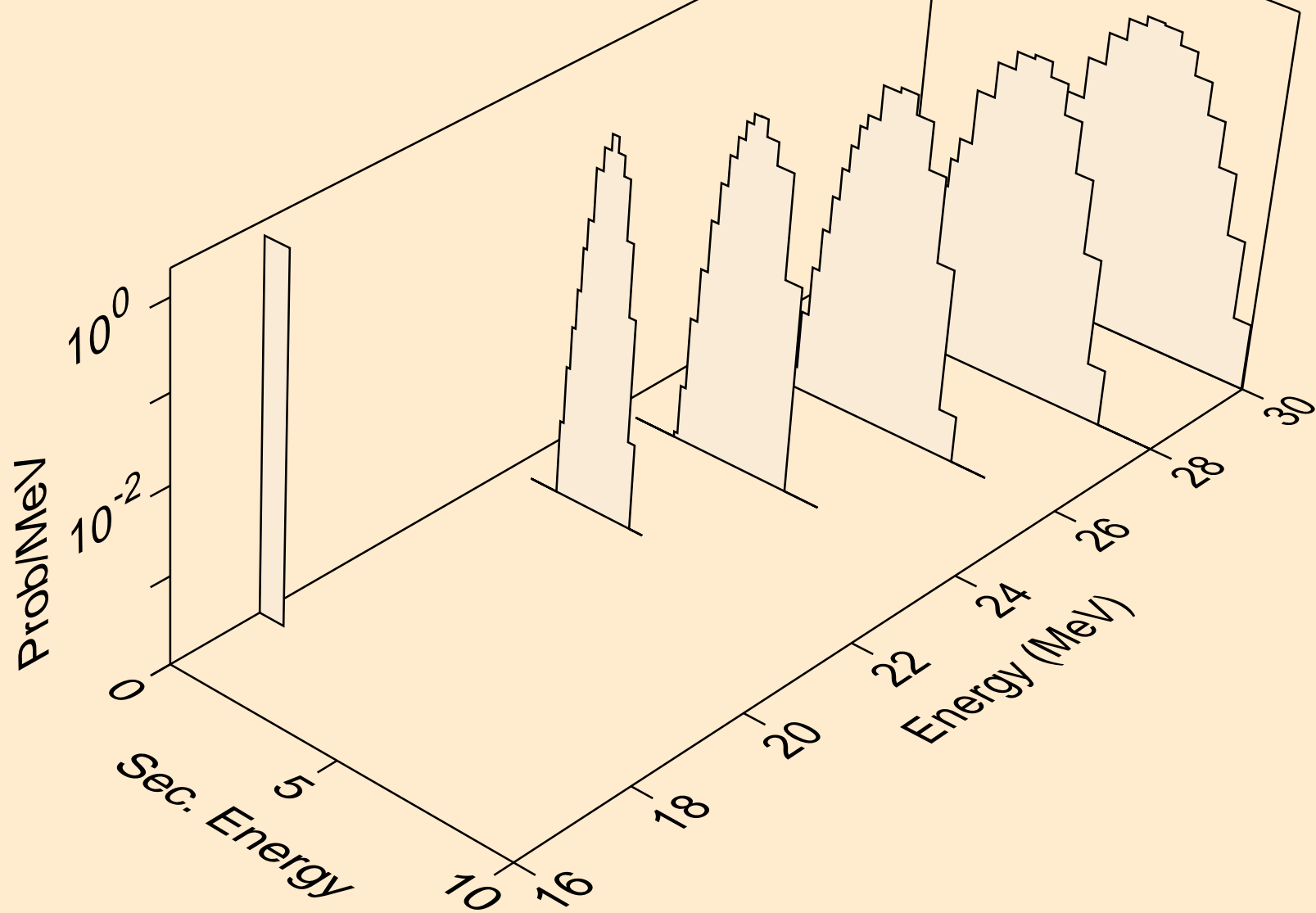

AG111 NEUTRON ACER TENDL-2024 LIBRARY; T=293.6K  
he3s from (n,x)

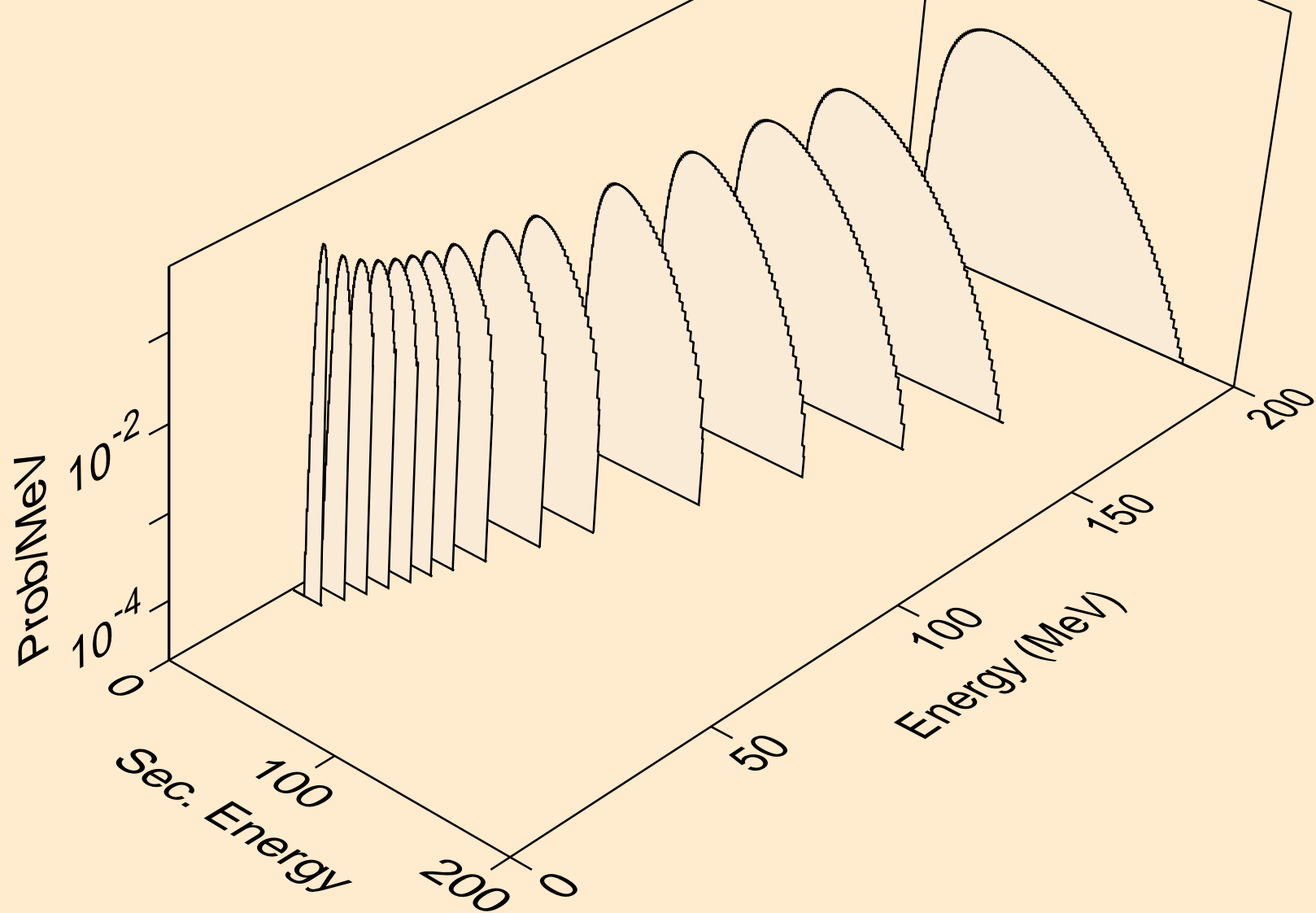

AG111 NEUTRON ACER TENDL-2024 LIBRARY; T=293.6K  
he3s from (n,n\*)he3

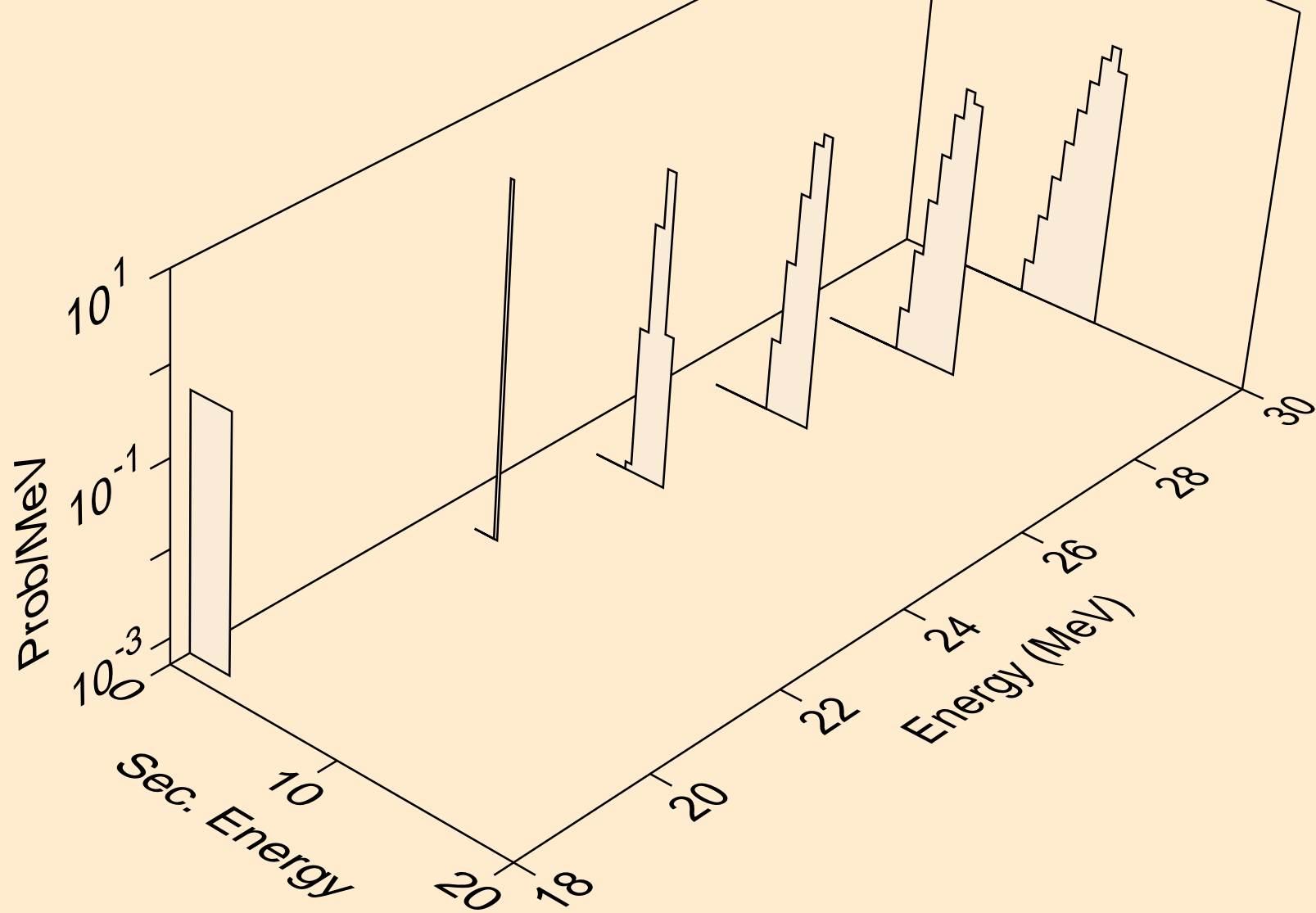

AG111 NEUTRON ACER TENDL-2024 LIBRARY; T=293.6K  
he3s from (n,he3)

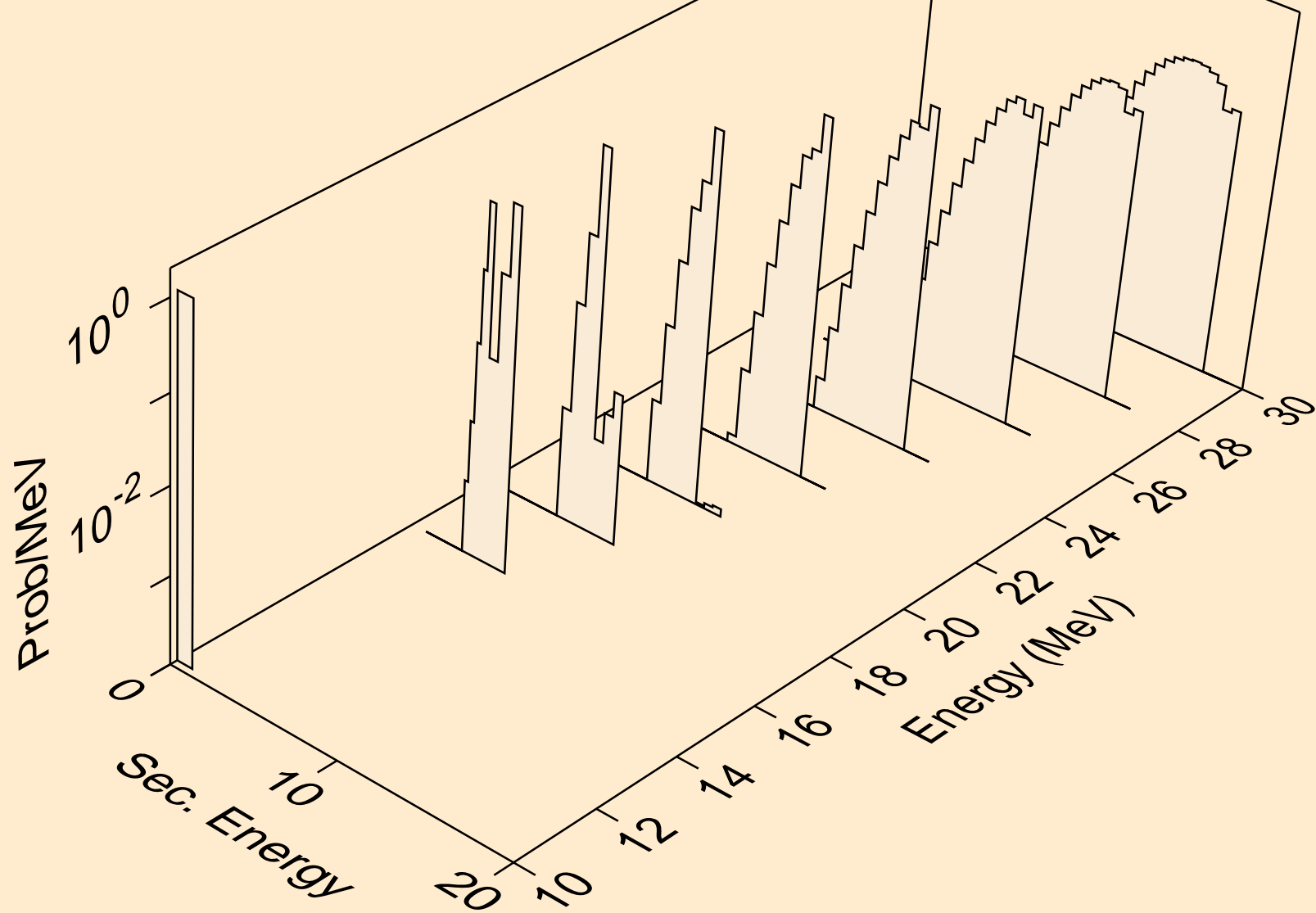

AG111 NEUTRON ACER TENDL-2024 LIBRARY; T=293.6K  
alphas from (n,x)

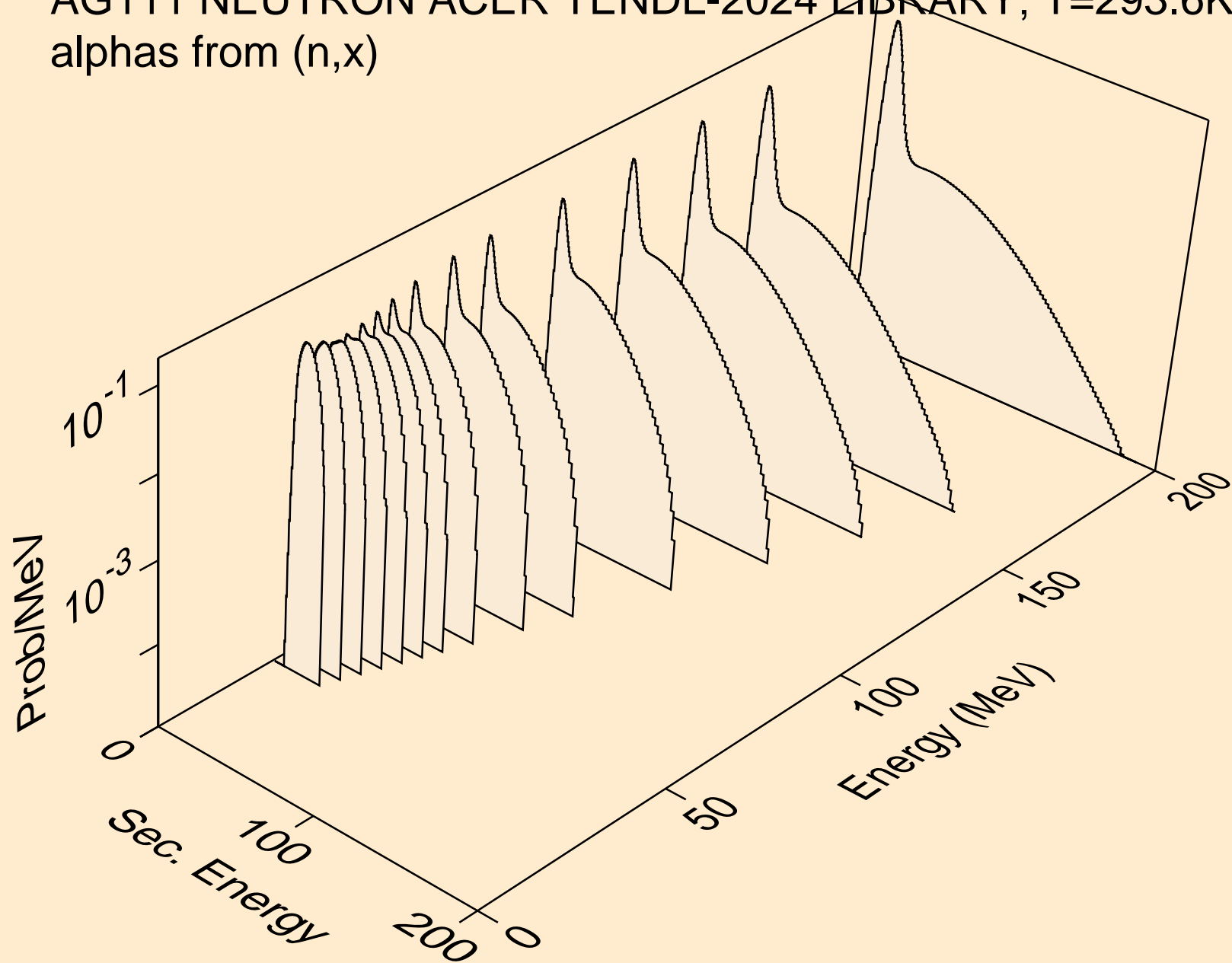

AG111 NEUTRON ACER TENDL-2024 LIBRARY; T=293.6K  
alphas from (n,n\*)a

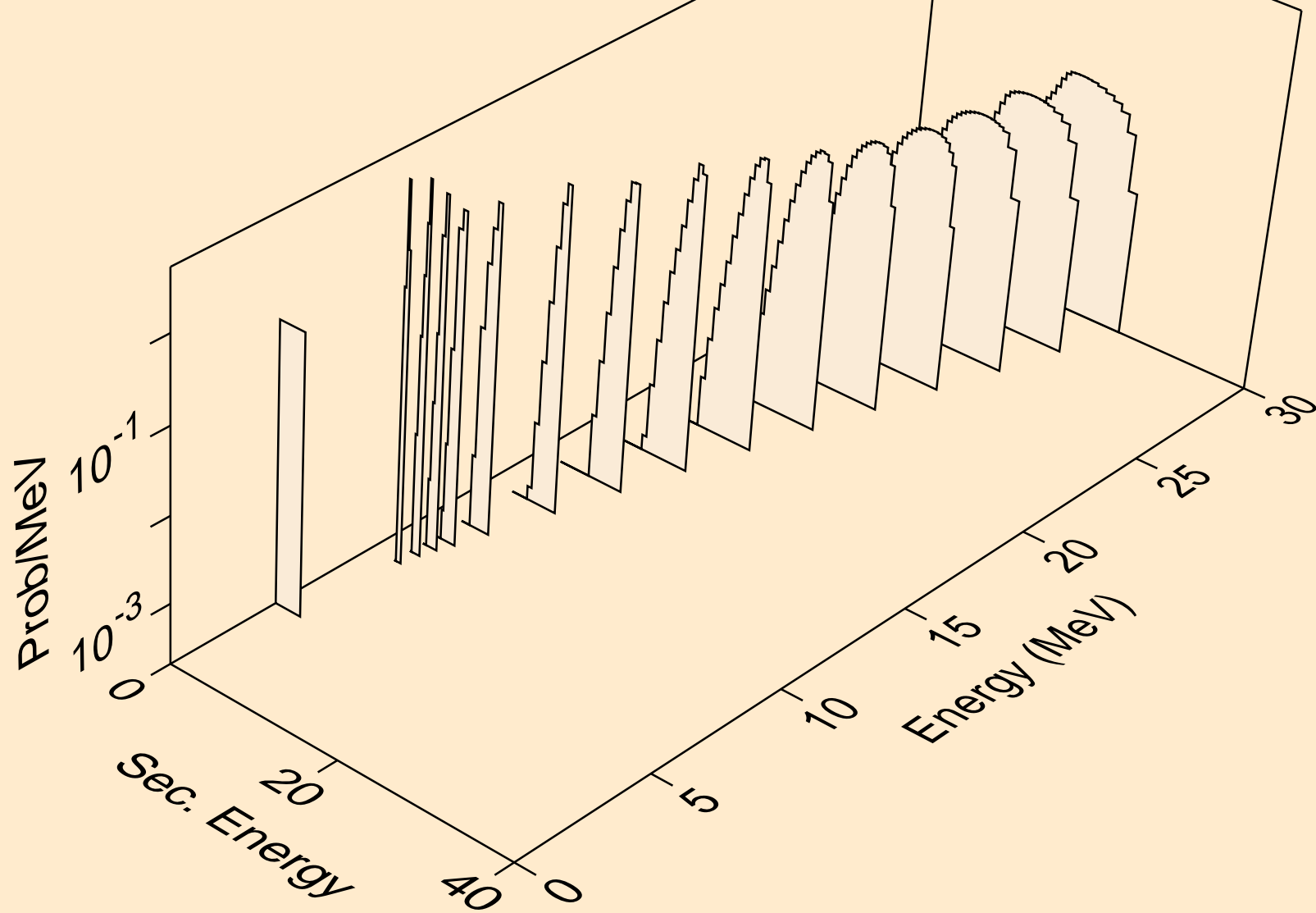

AG111 NEUTRON ACER TENDL-2024 LIBRARY; T=293.6K  
alphas from (n,2n)a

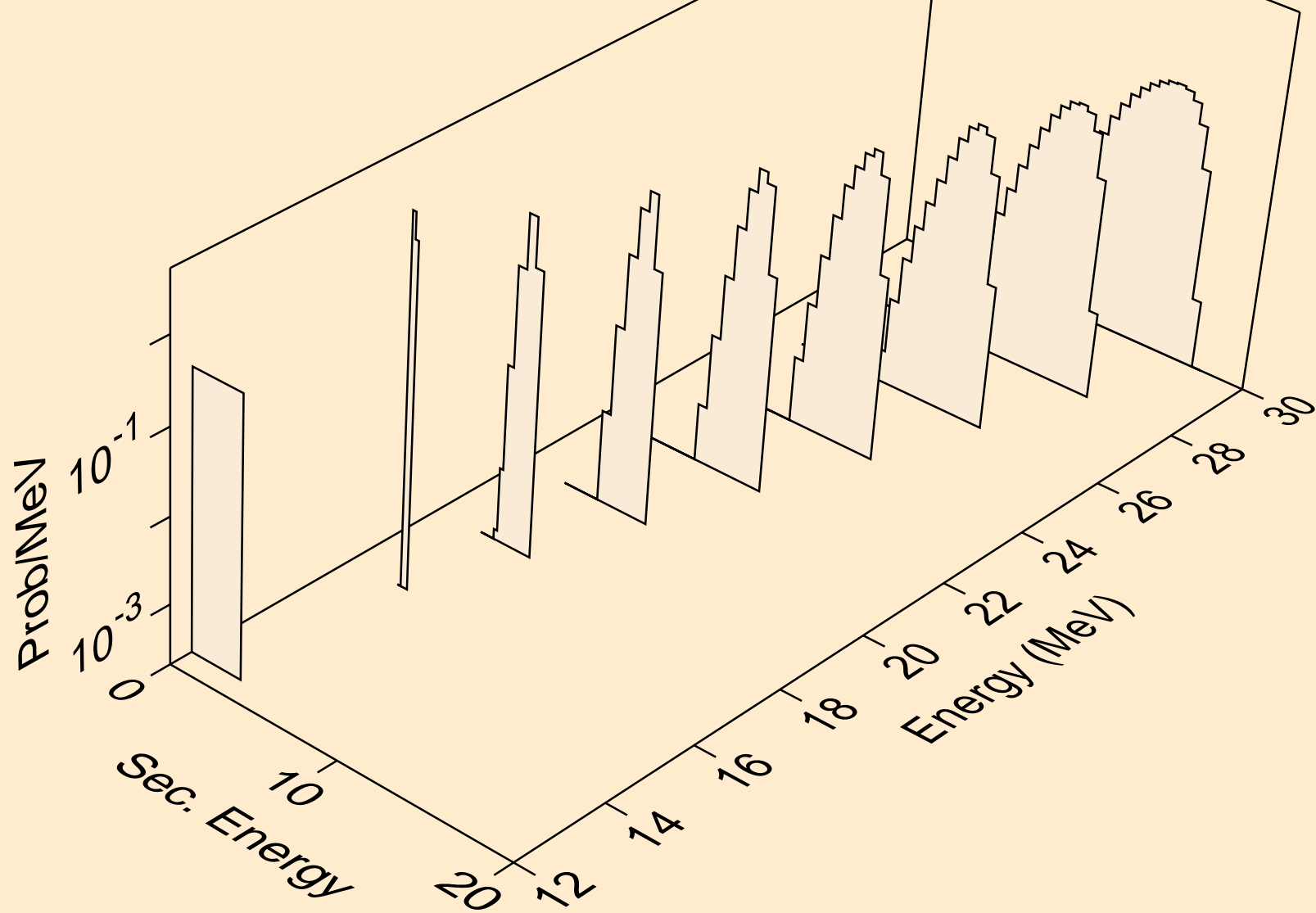

AG111 NEUTRON ACER TENDL-2024 LIBRARY; T=293.6K  
alphas from (n,3n)a

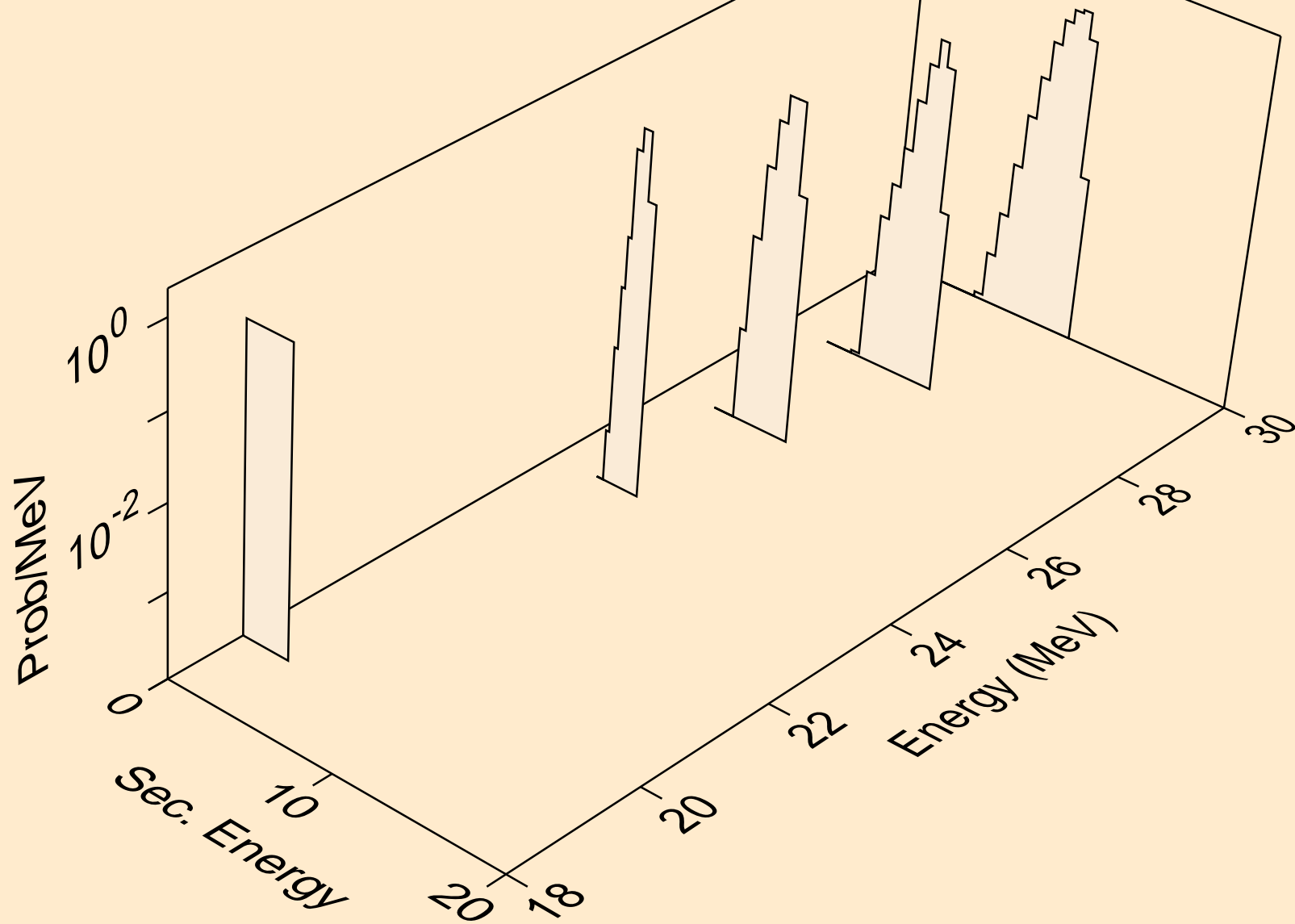

AG111 NEUTRON ACER TENDL-2024 LIBRARY; T=293.6K  
alphas from (n,n\*)2a

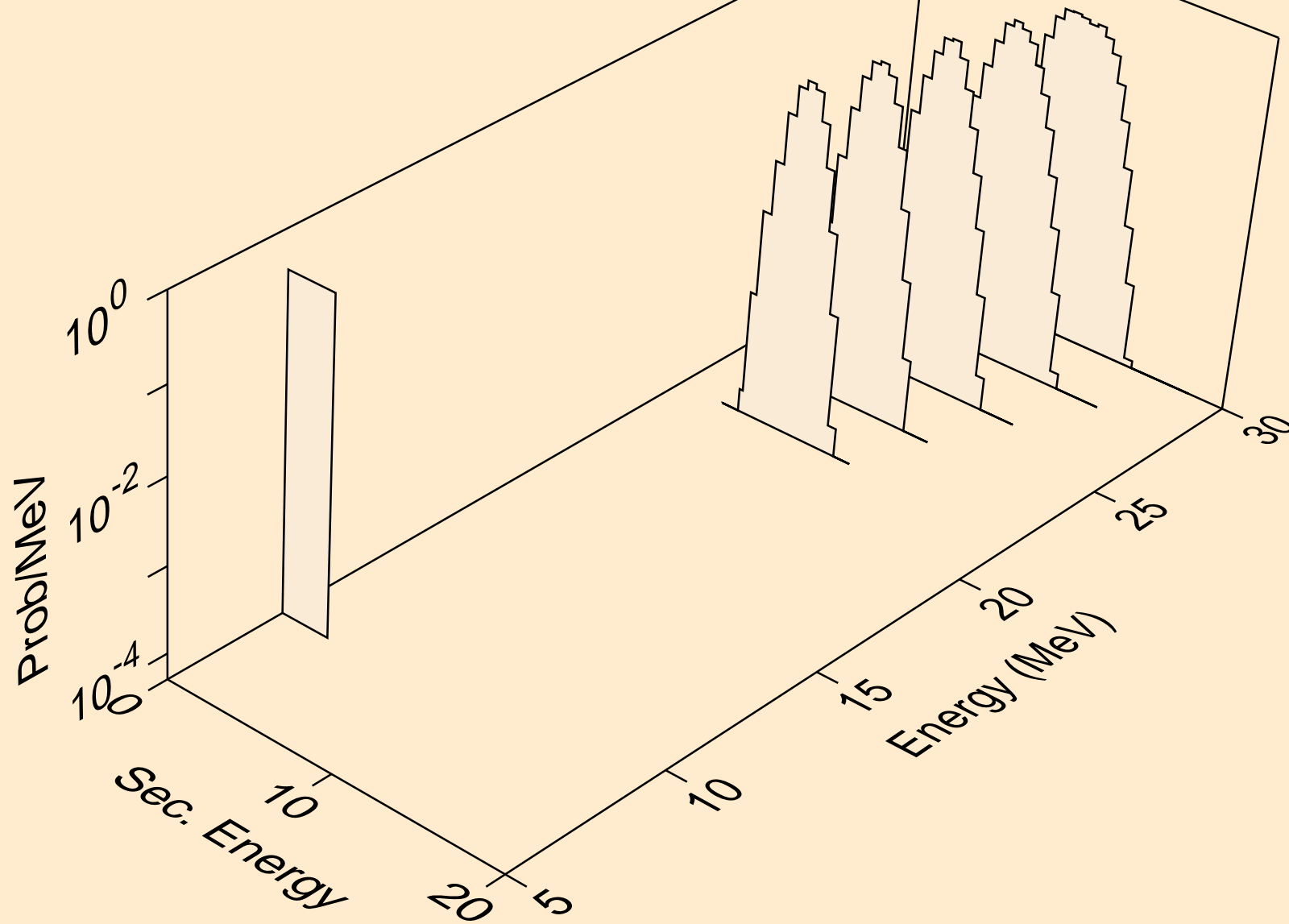

AG111 NEUTRON ACER TENDL-2024 LIBRARY; T=293.6K  
alphas from (n,npa)

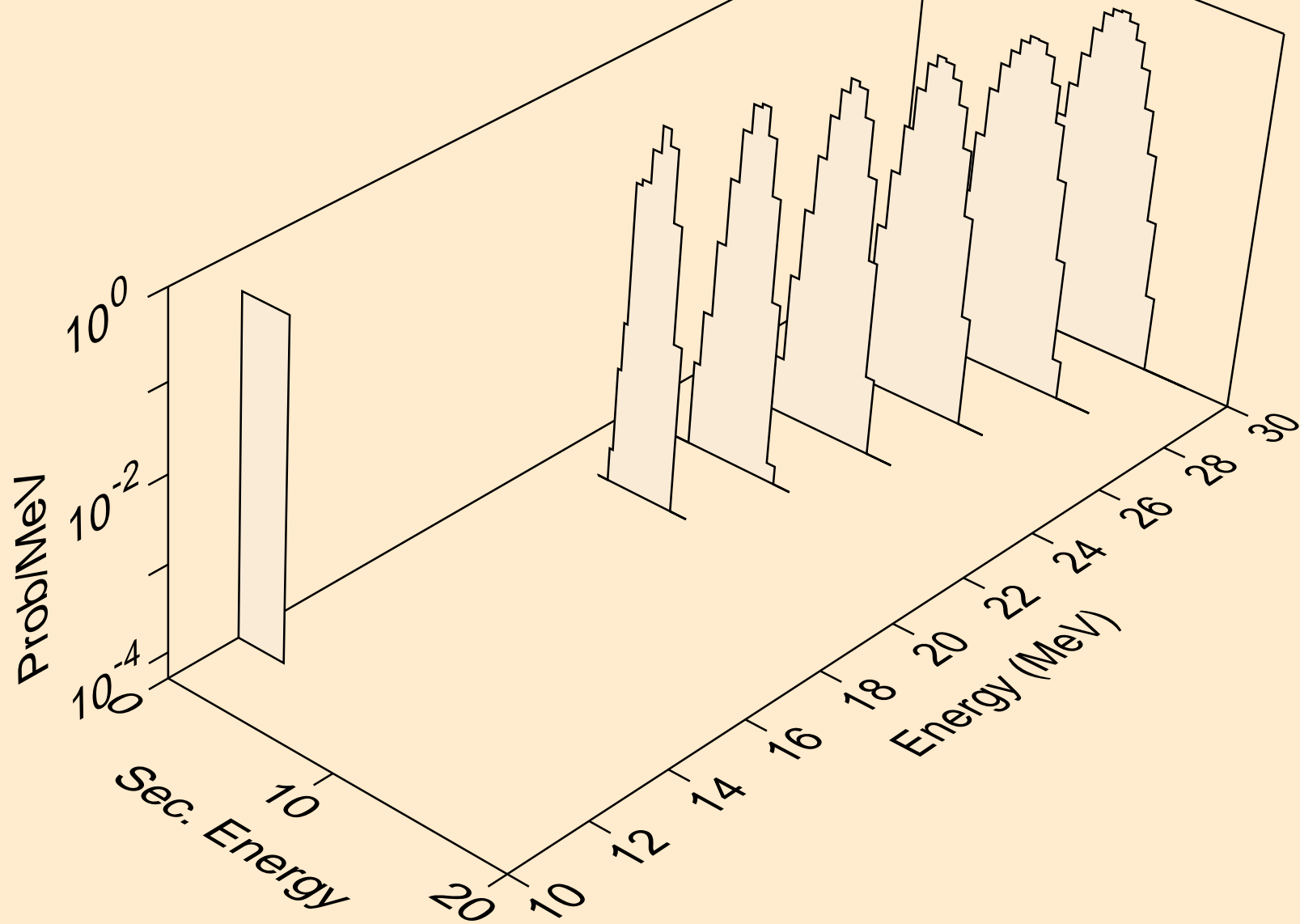

AG111 NEUTRON ACER TENDL-2024 LIBRARY; T=293.6K  
alphas from (n,a)

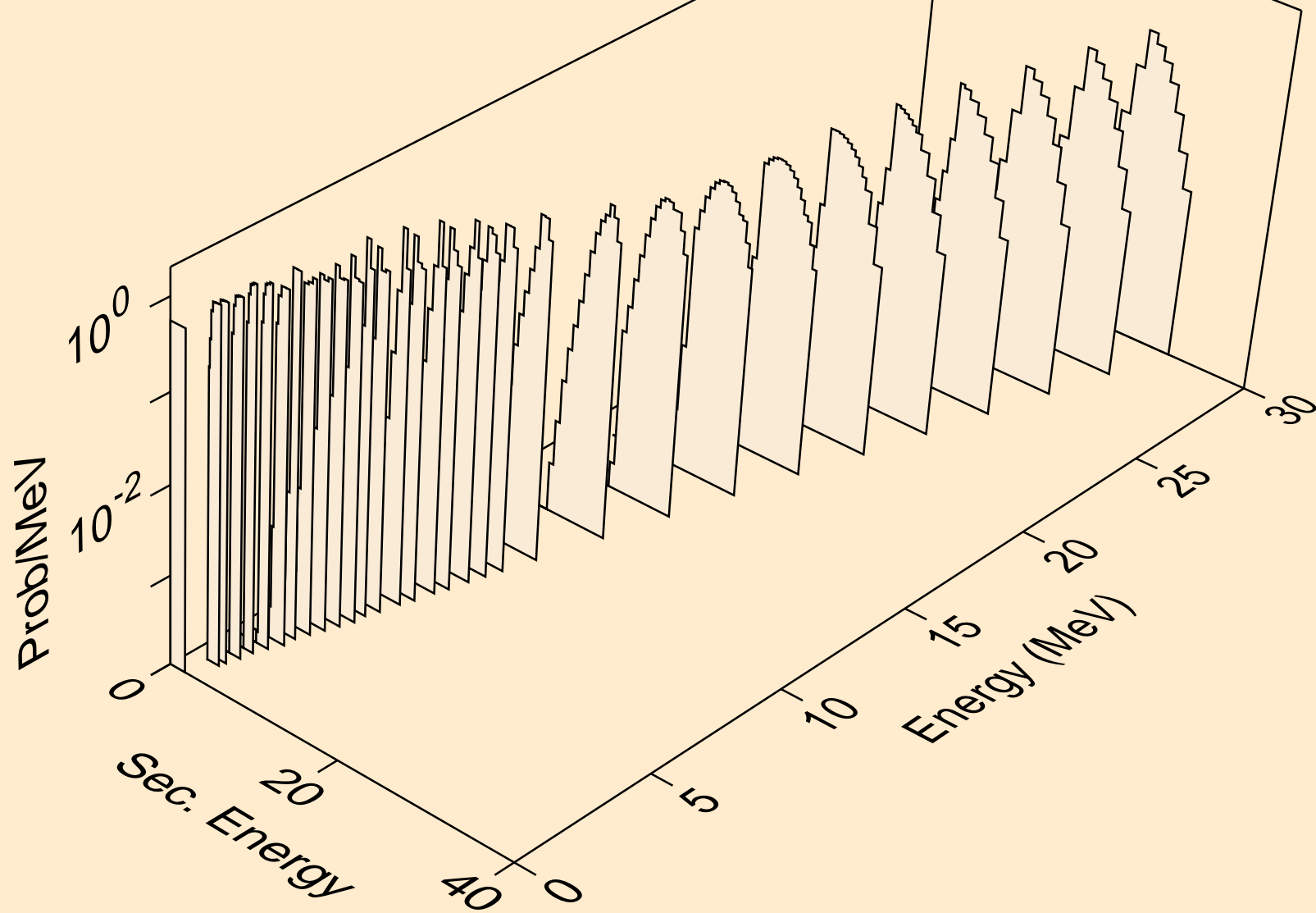

AG111 NEUTRON ACER TENDL-2024 LIBRARY; T=293.6K  
alphas from (n,2a)

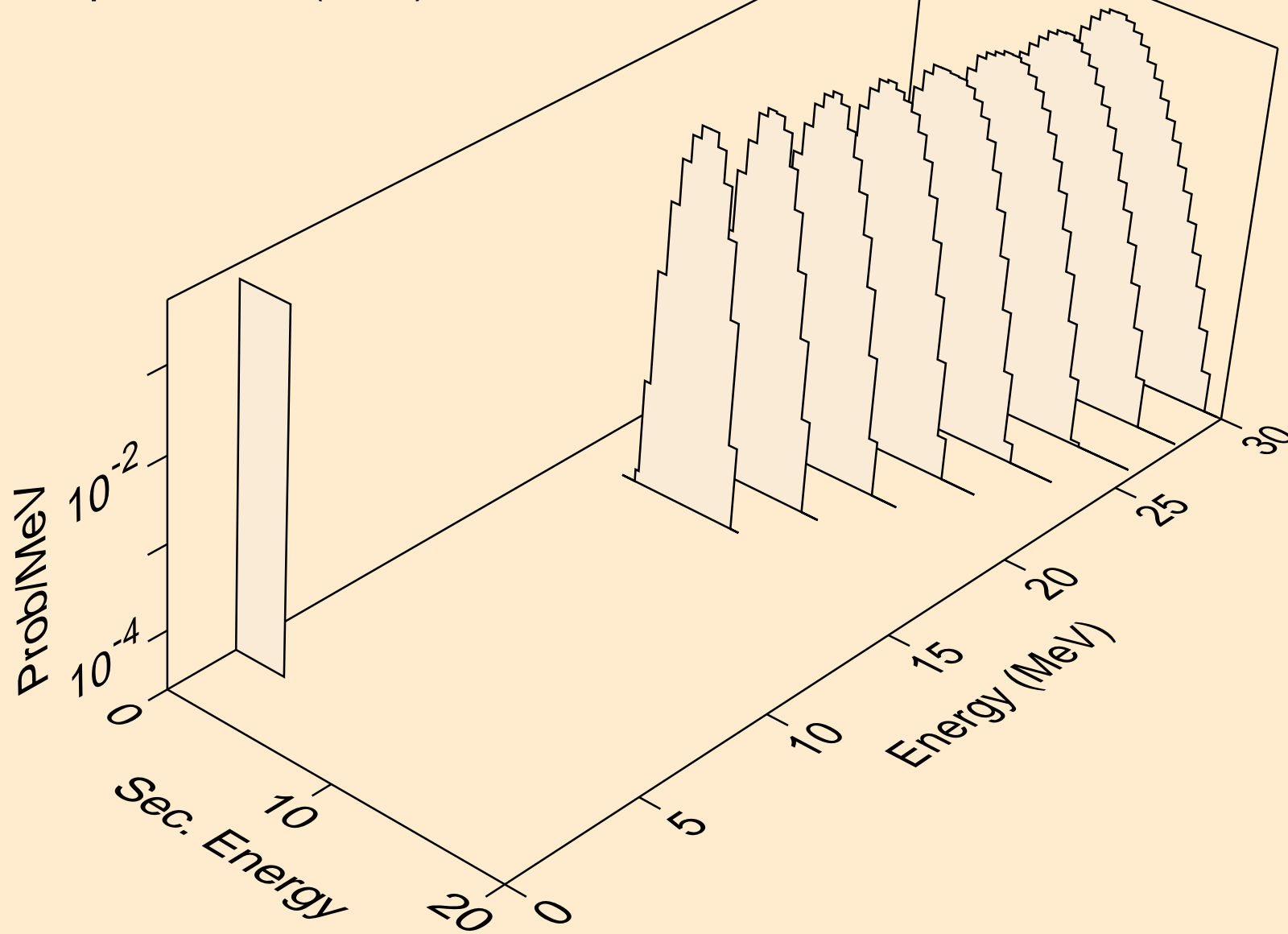

AG111 NEUTRON ACER TENDL-2024 LIBRARY; T=293.6K  
alphas from (n,pa)

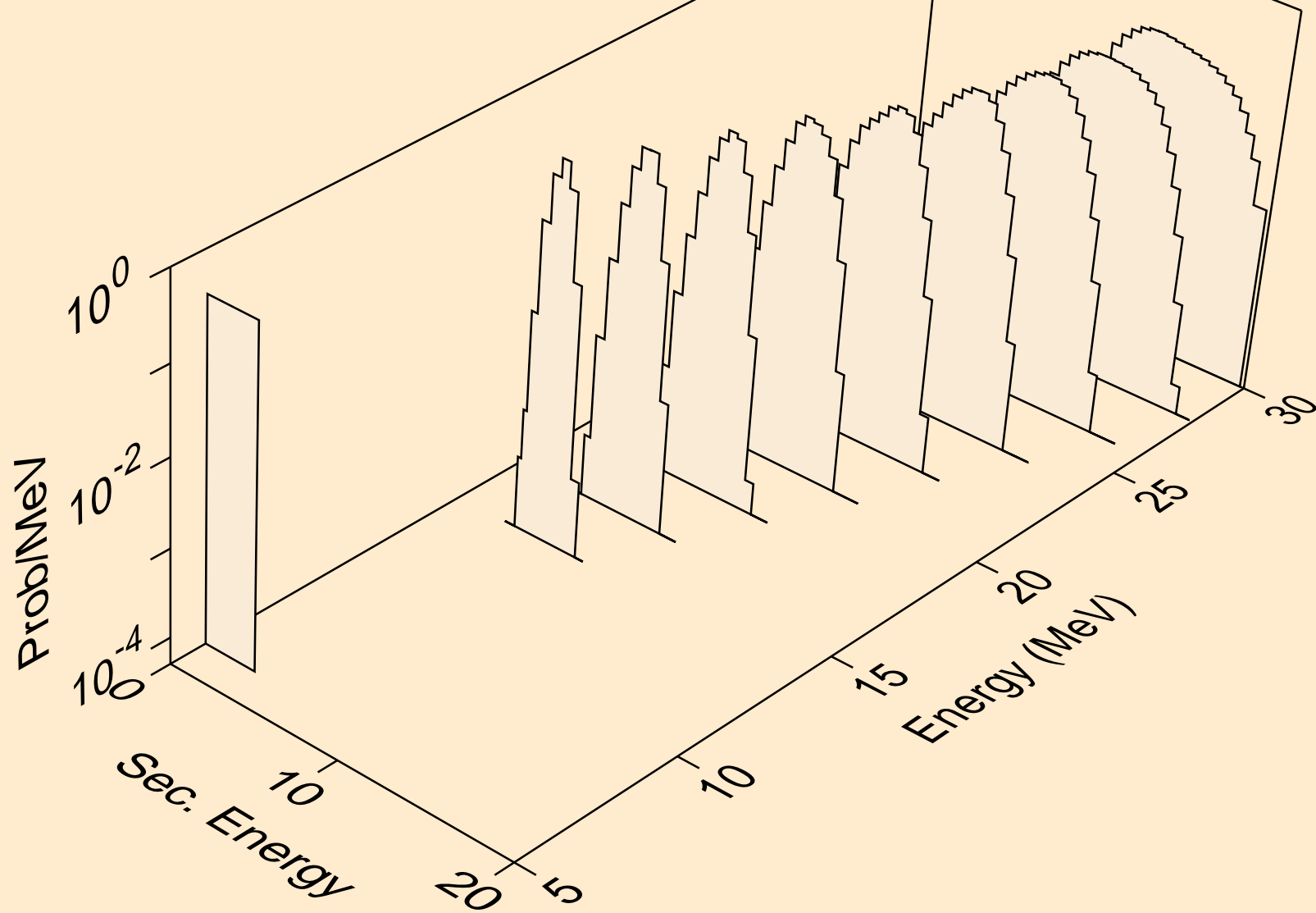

AG111 NEUTRON ACER TENDL-2024 LIBRARY; T=293.6K  
alphas from (n,da)

