

# HF177N NEUTRON ACER TENDL-2024 LIBRARY; T=293.6K

## Principal cross sections

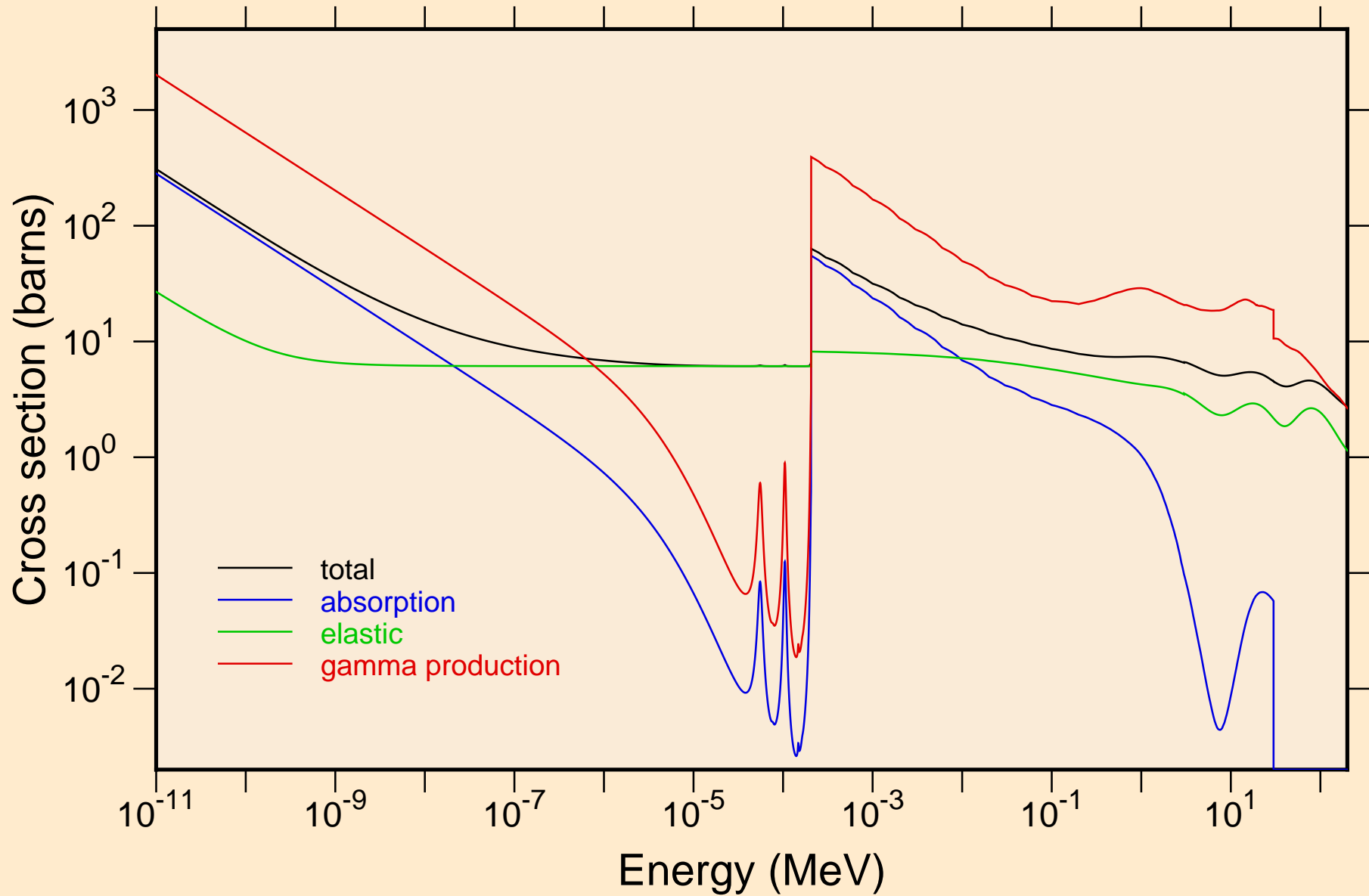

HF177N NEUTRON ACER TENDL-2024 LIBRARY; T=293.6K  
Heating

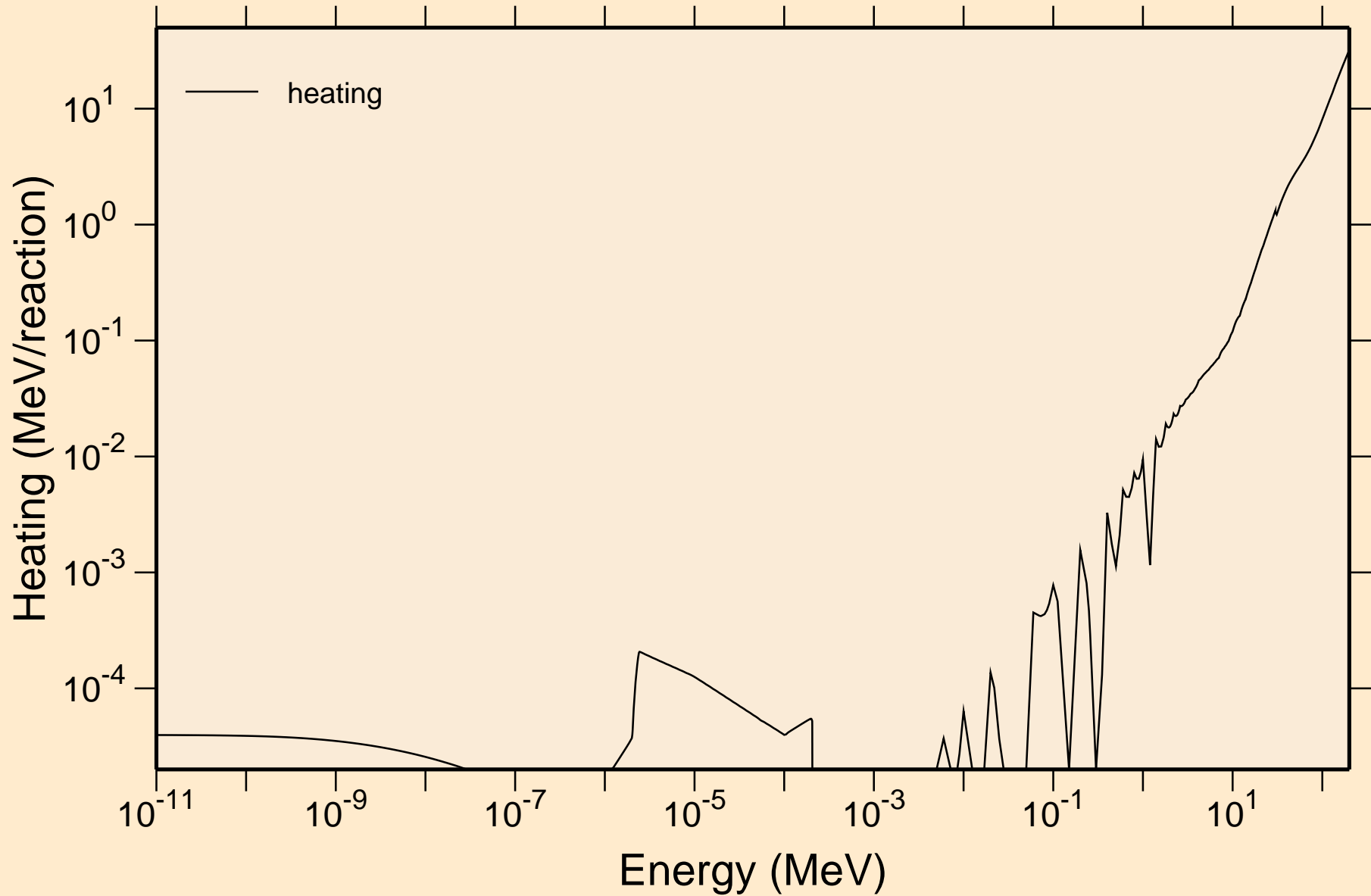

# HF177N NEUTRON ACER TENDL-2024 LIBRARY; T=293.6K

## Damage

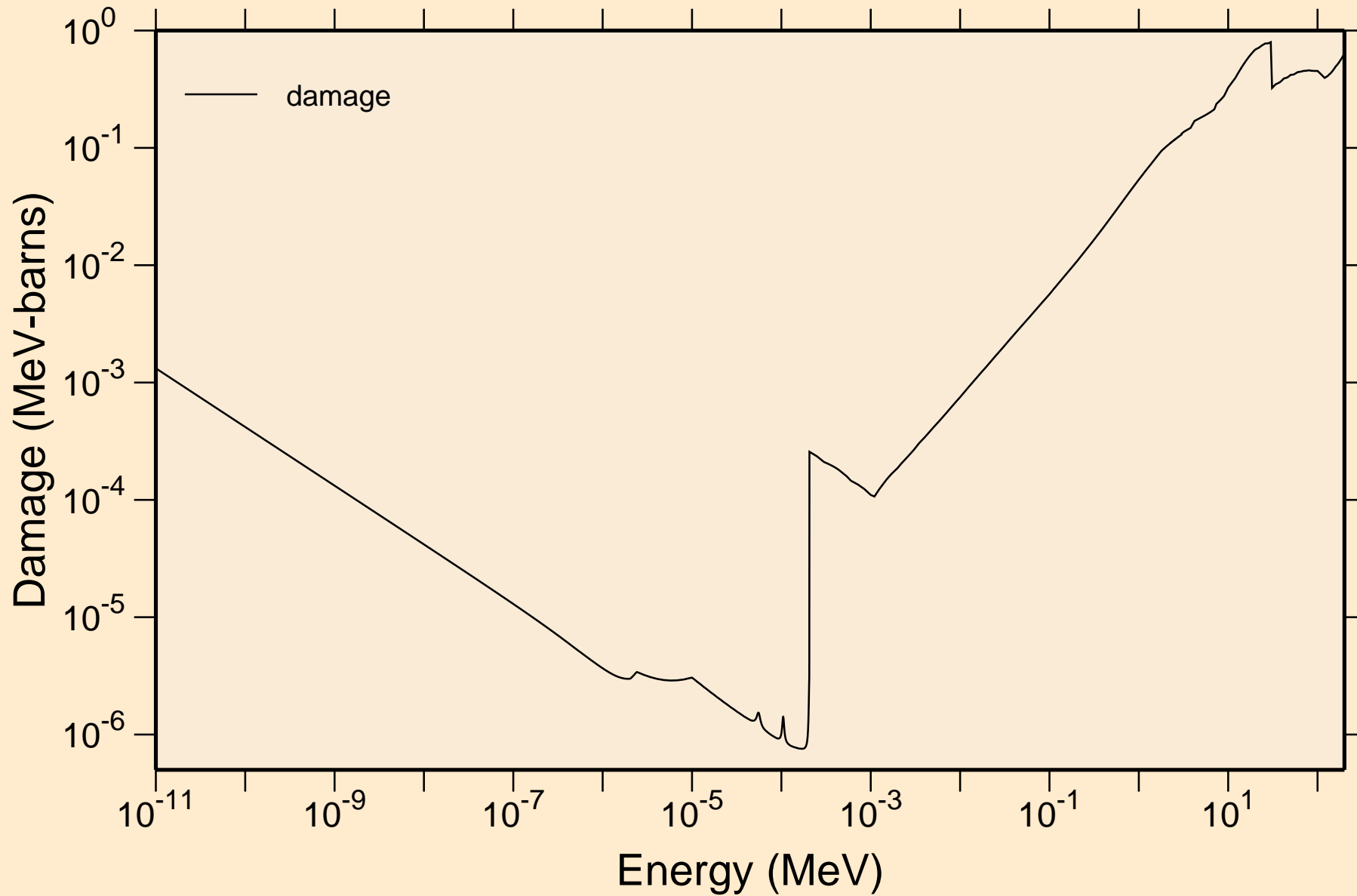

# HF177N NEUTRON ACER TENDL-2024 LIBRARY; T=293.6K

## Non-threshold reactions

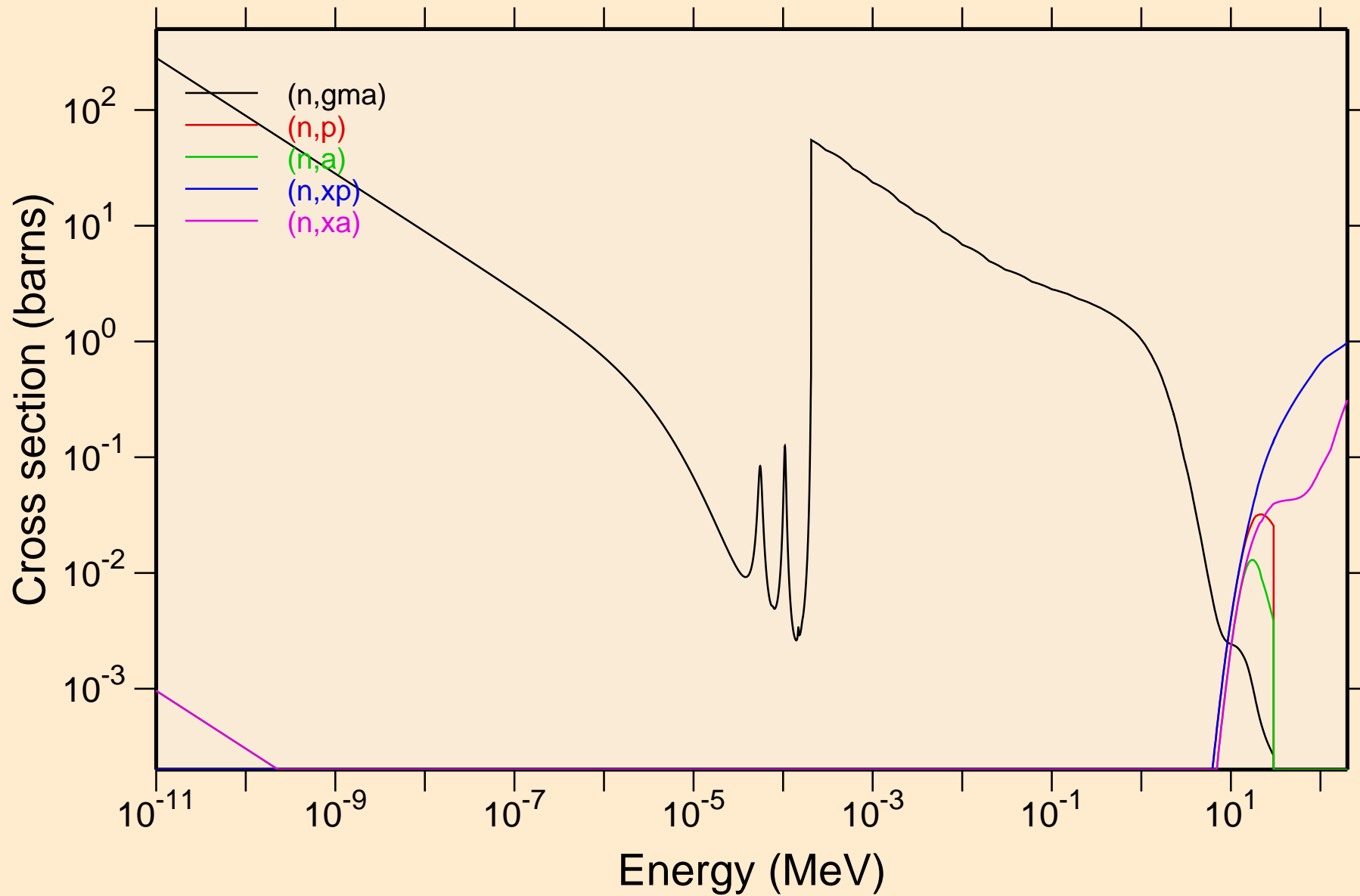

# HF177N NEUTRON ACER TENDL-2024 LIBRARY; T=293.6K

## Principal cross sections

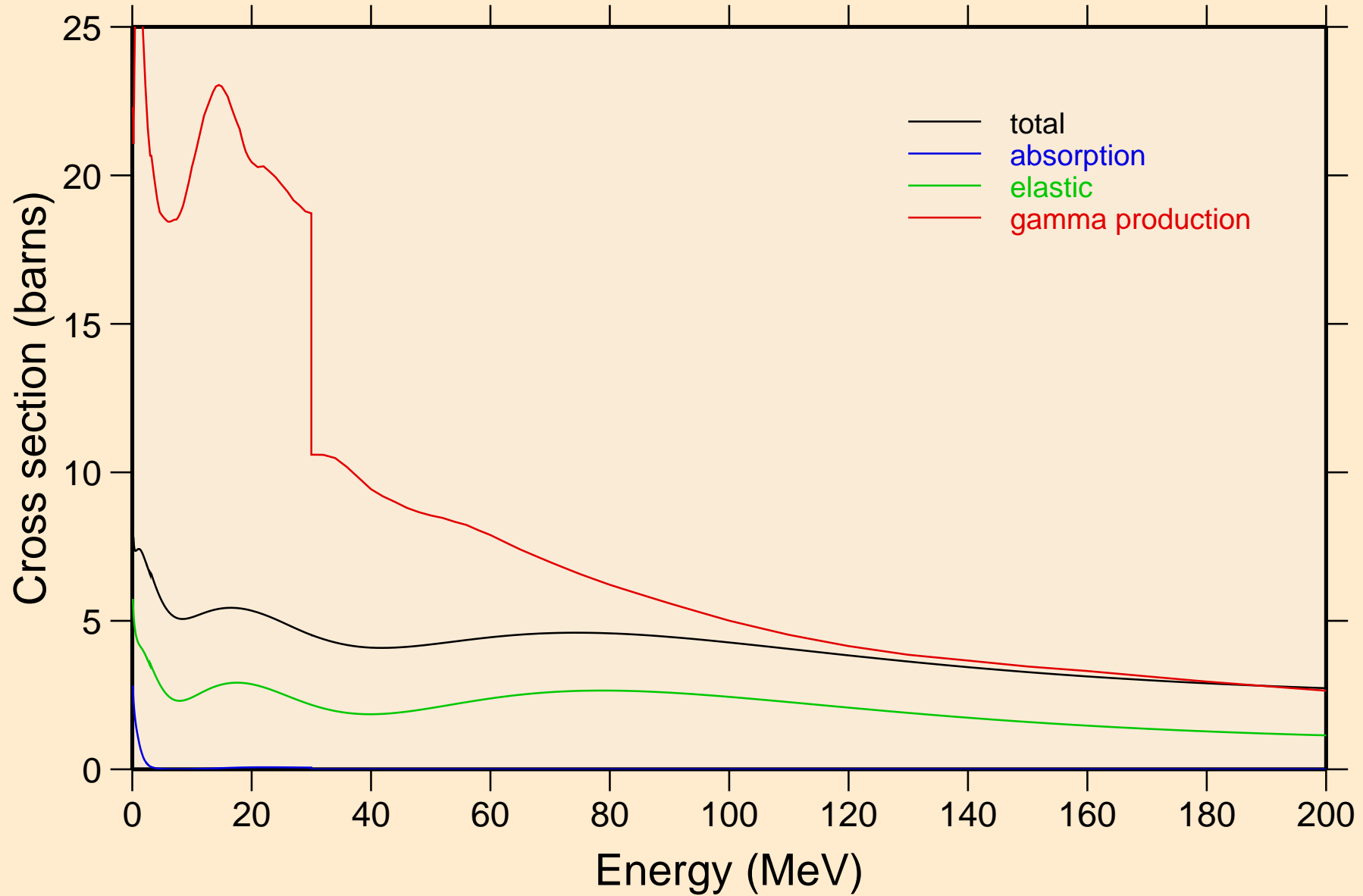

HF177N NEUTRON ACER TENDL-2024 LIBRARY; T=293.6K  
Heating

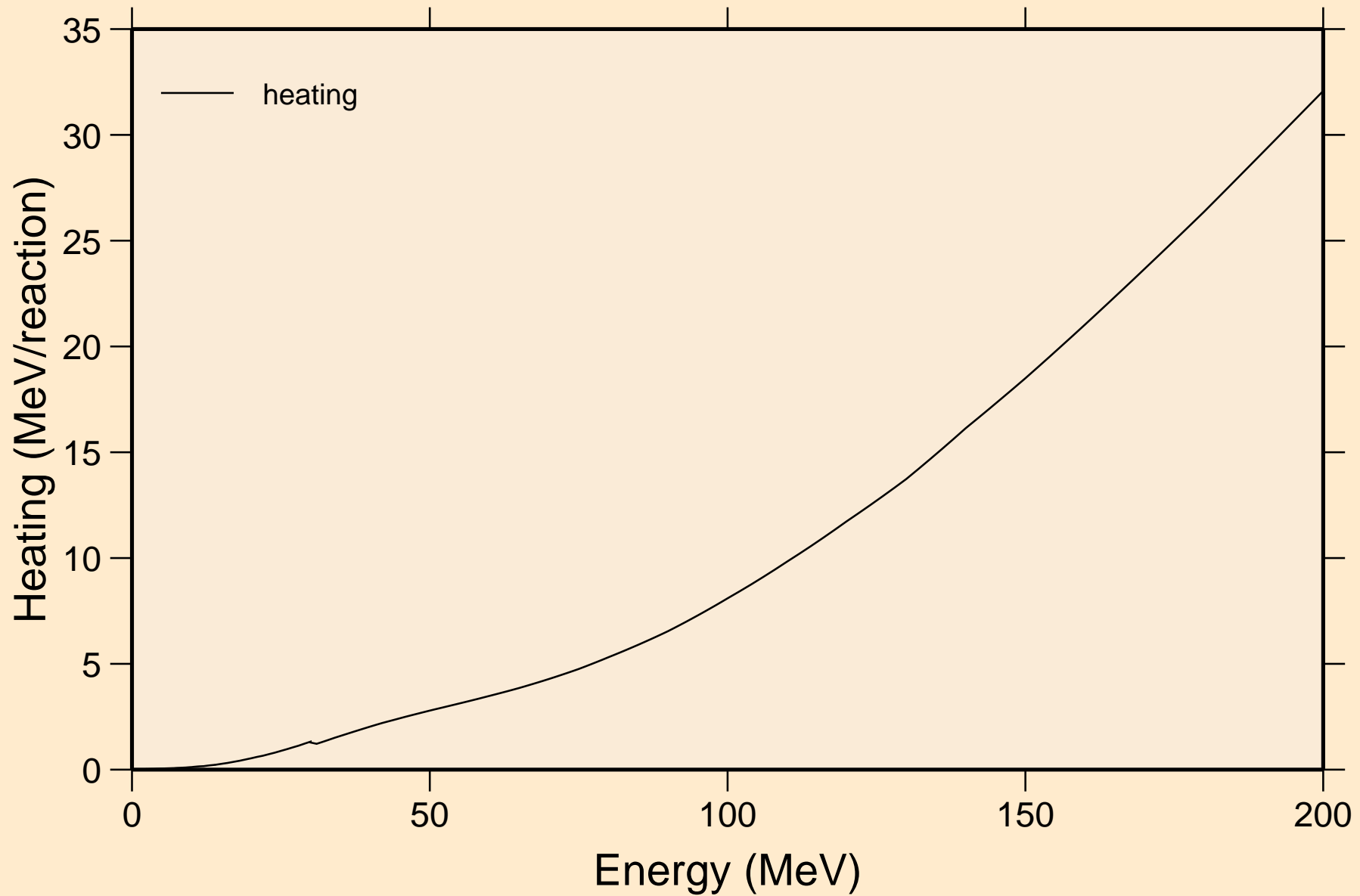

HF177N NEUTRON ACER TENDL-2024 LIBRARY; T=293.6K  
Damage

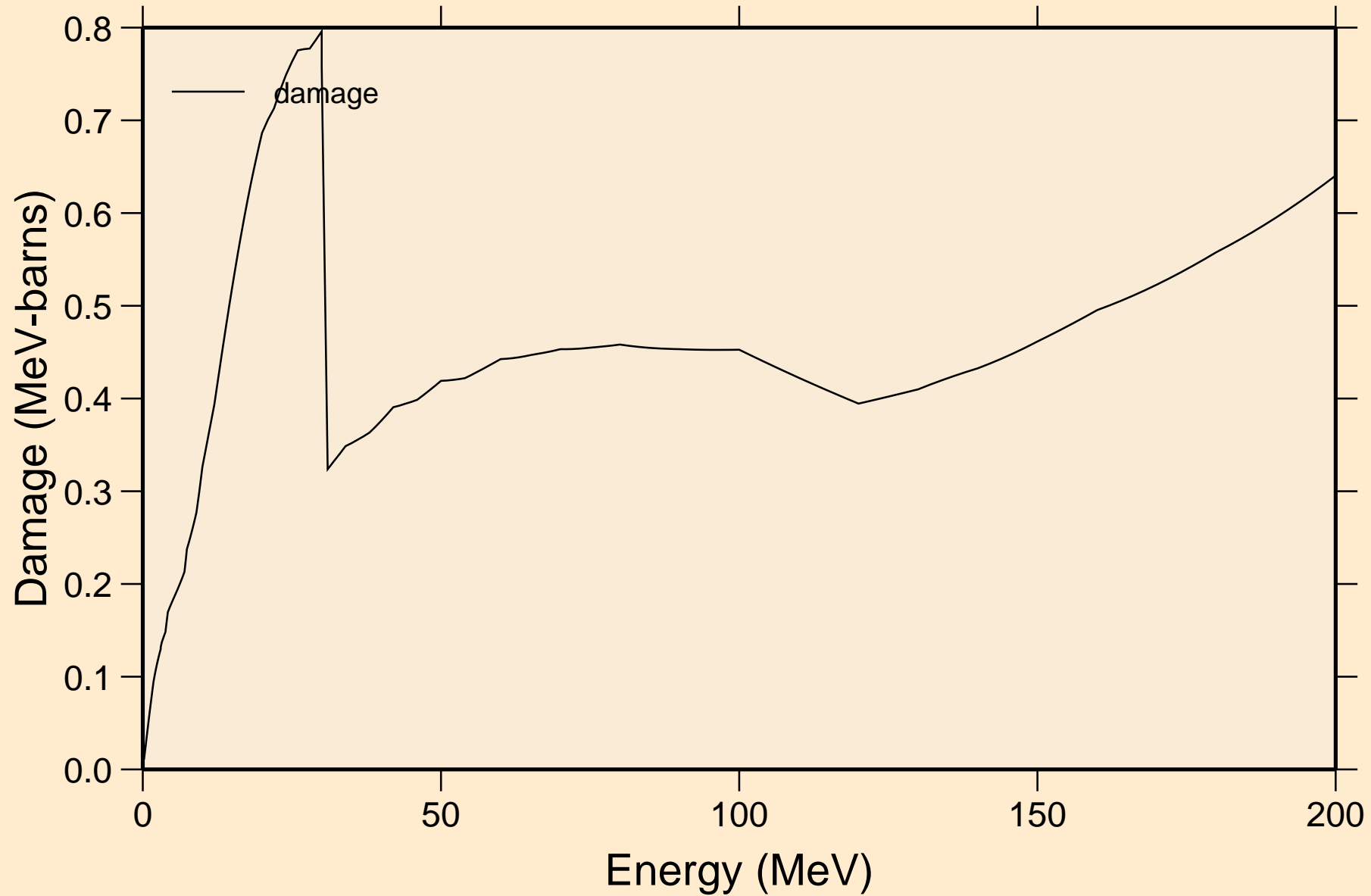

HF177N NEUTRON ACER TENDL-2024 LIBRARY; T=293.6K  
Non-threshold reactions

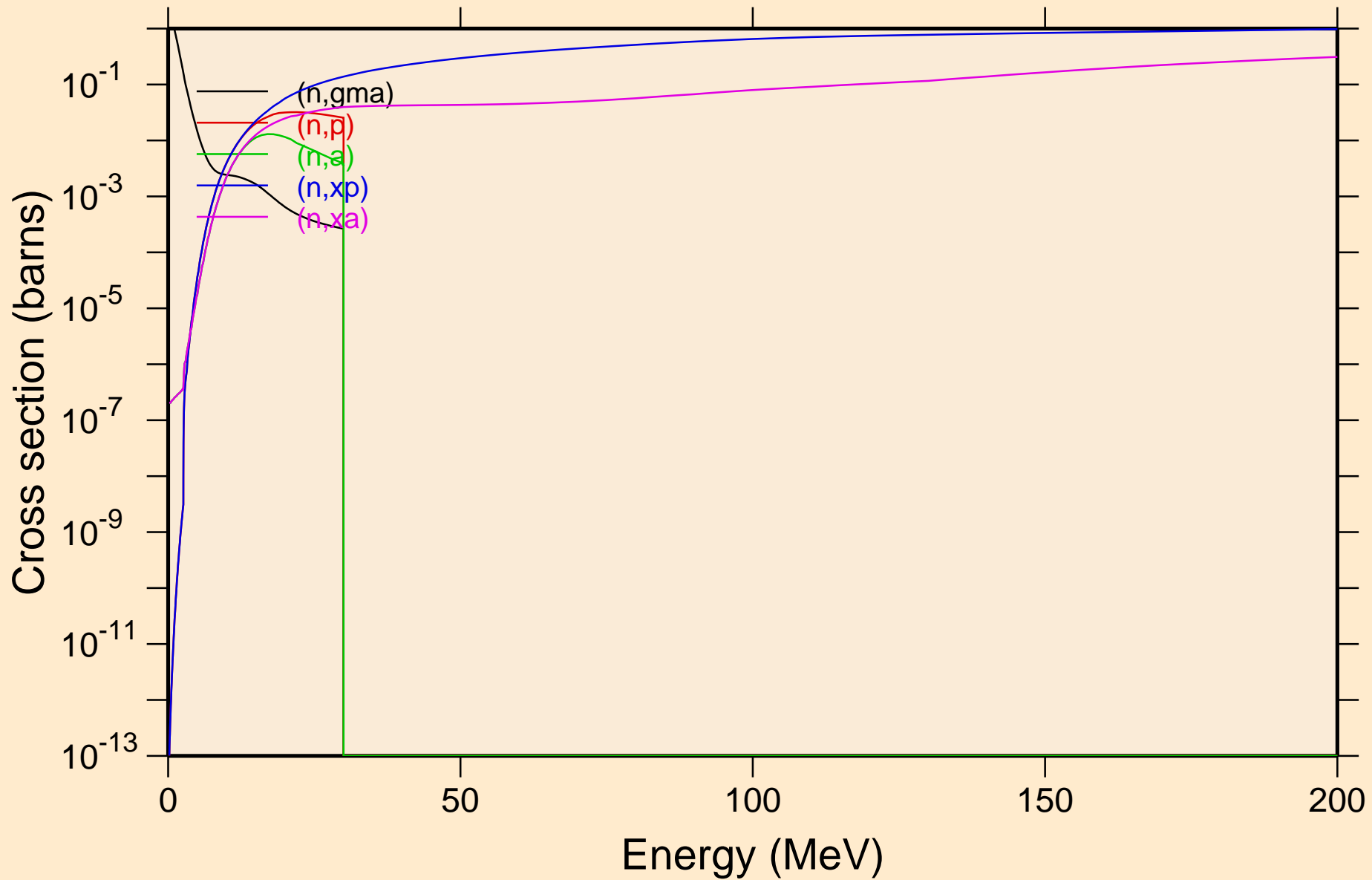

# HF177N NEUTRON ACER TENDL-2024 LIBRARY; T=293.6K

## Inelastic levels

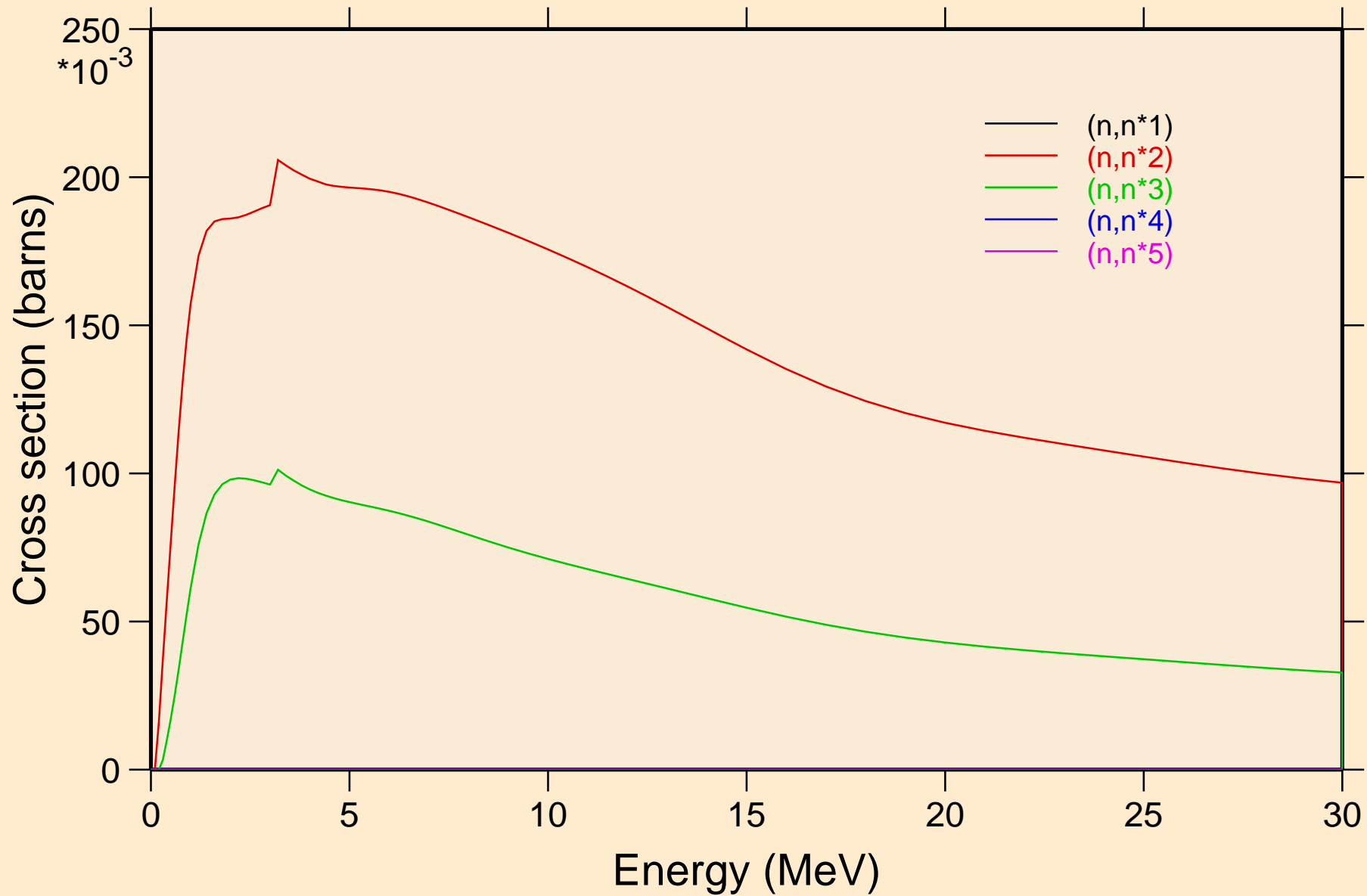

HF177N NEUTRON ACER TENDL-2024 LIBRARY; T=293.6K  
Inelastic levels

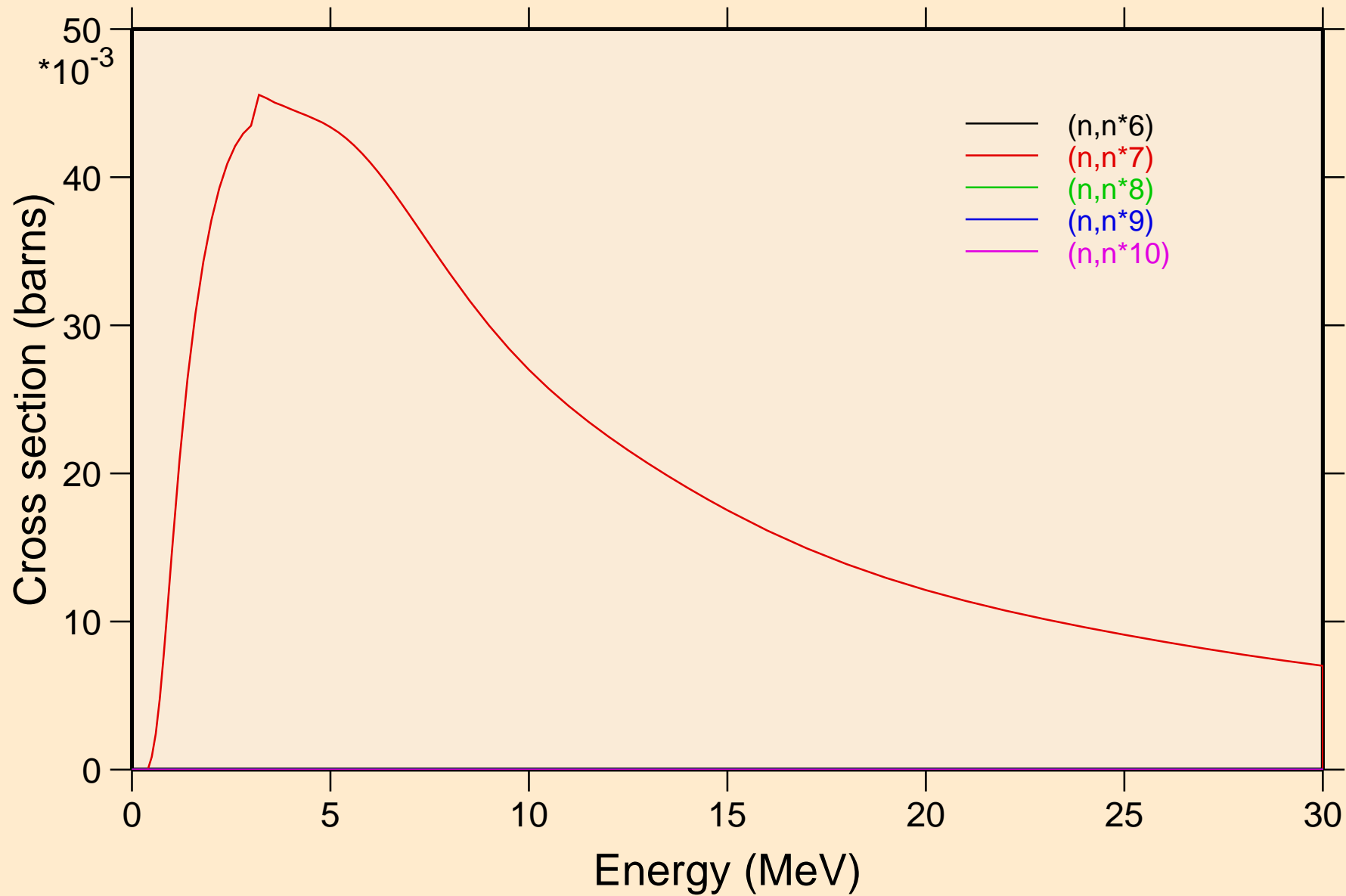

HF177N NEUTRON ACER TENDL-2024 LIBRARY; T=293.6K  
Inelastic levels

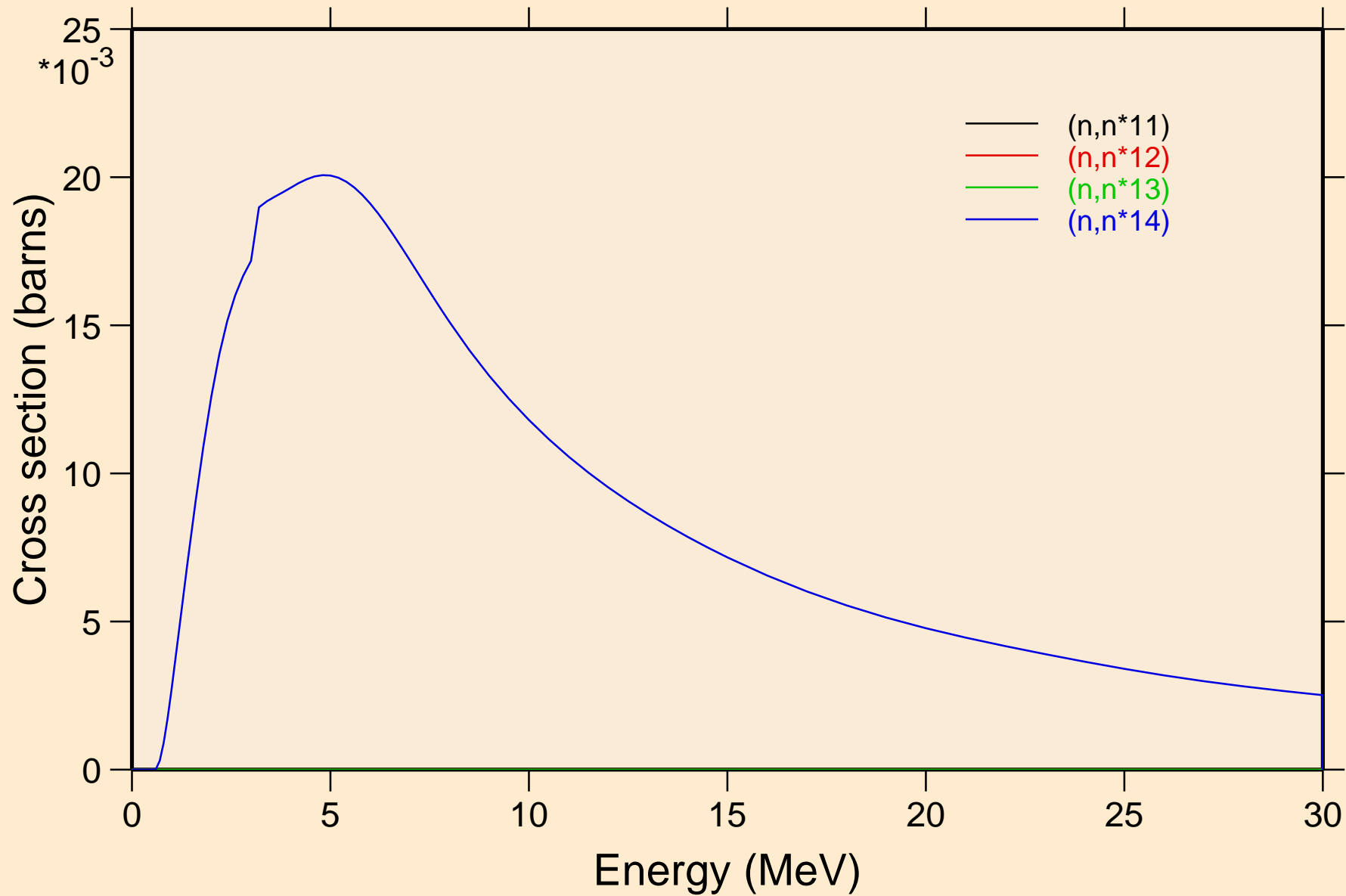

# HF177N NEUTRON ACER TENDL-2024 LIBRARY; T=293.6K

## Threshold reactions

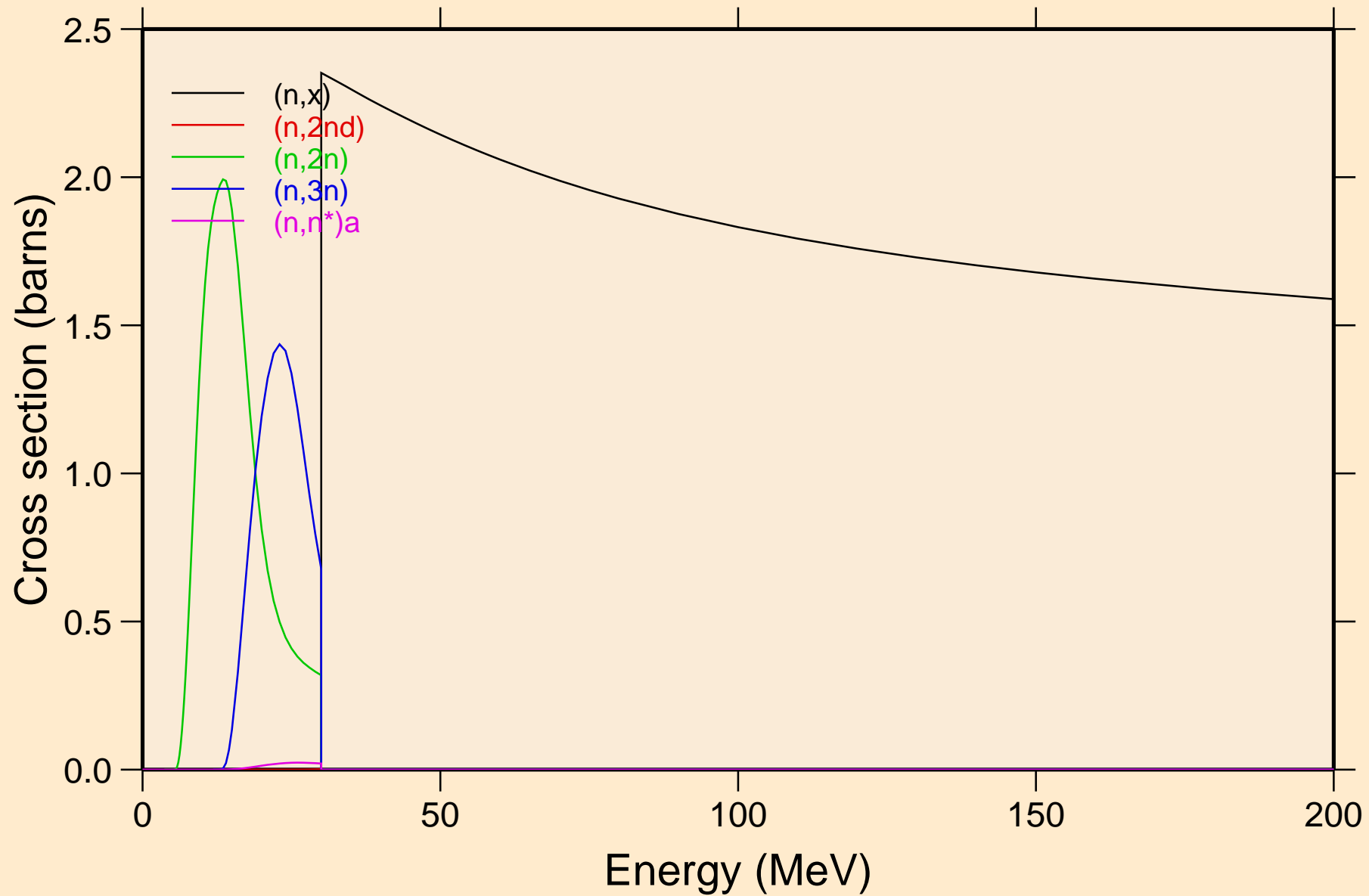

# HF177N NEUTRON ACER TENDL-2024 LIBRARY; T=293.6K

## Threshold reactions

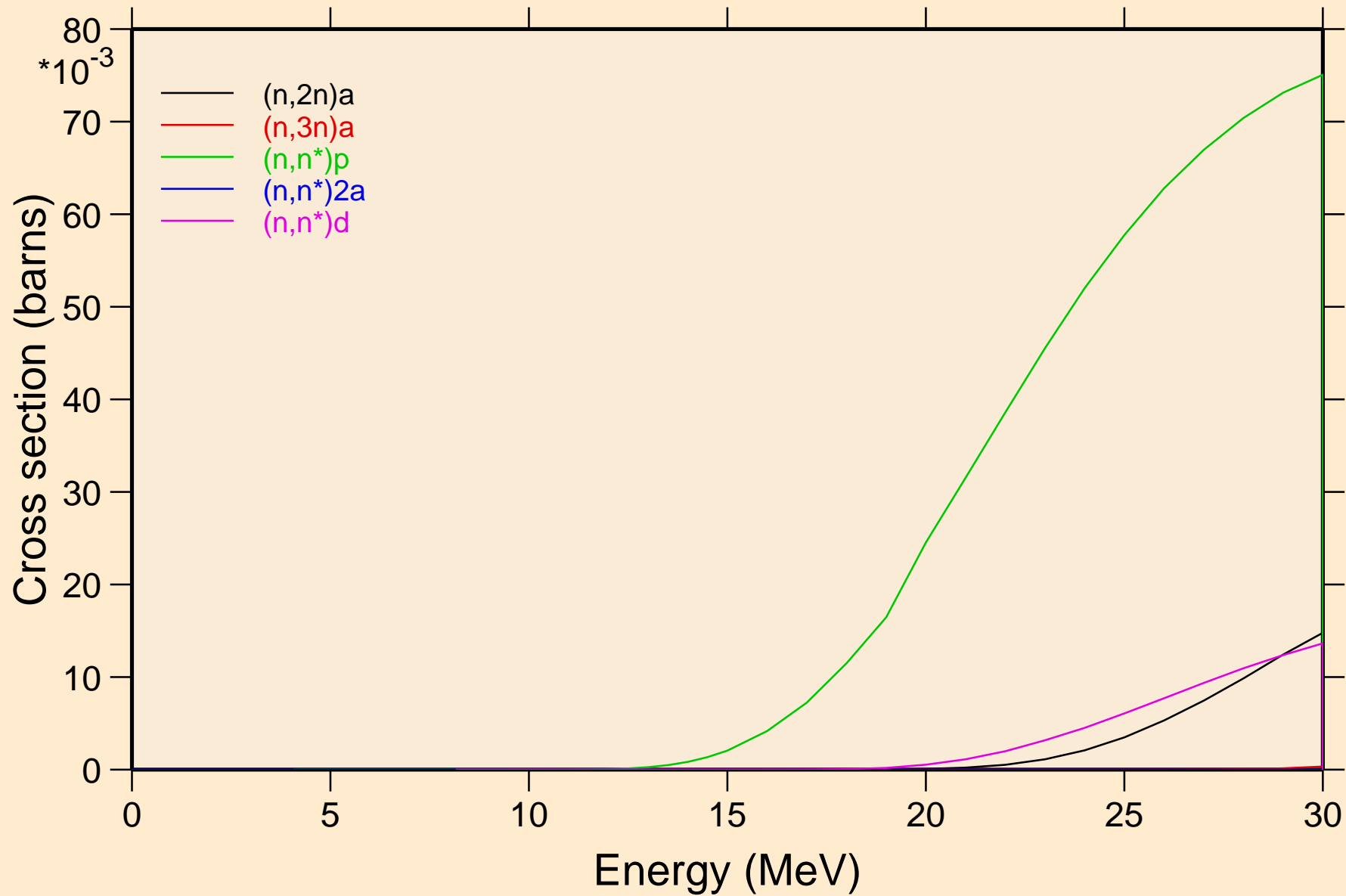

# HF177N NEUTRON ACER TENDL-2024 LIBRARY; T=293.6K

## Threshold reactions

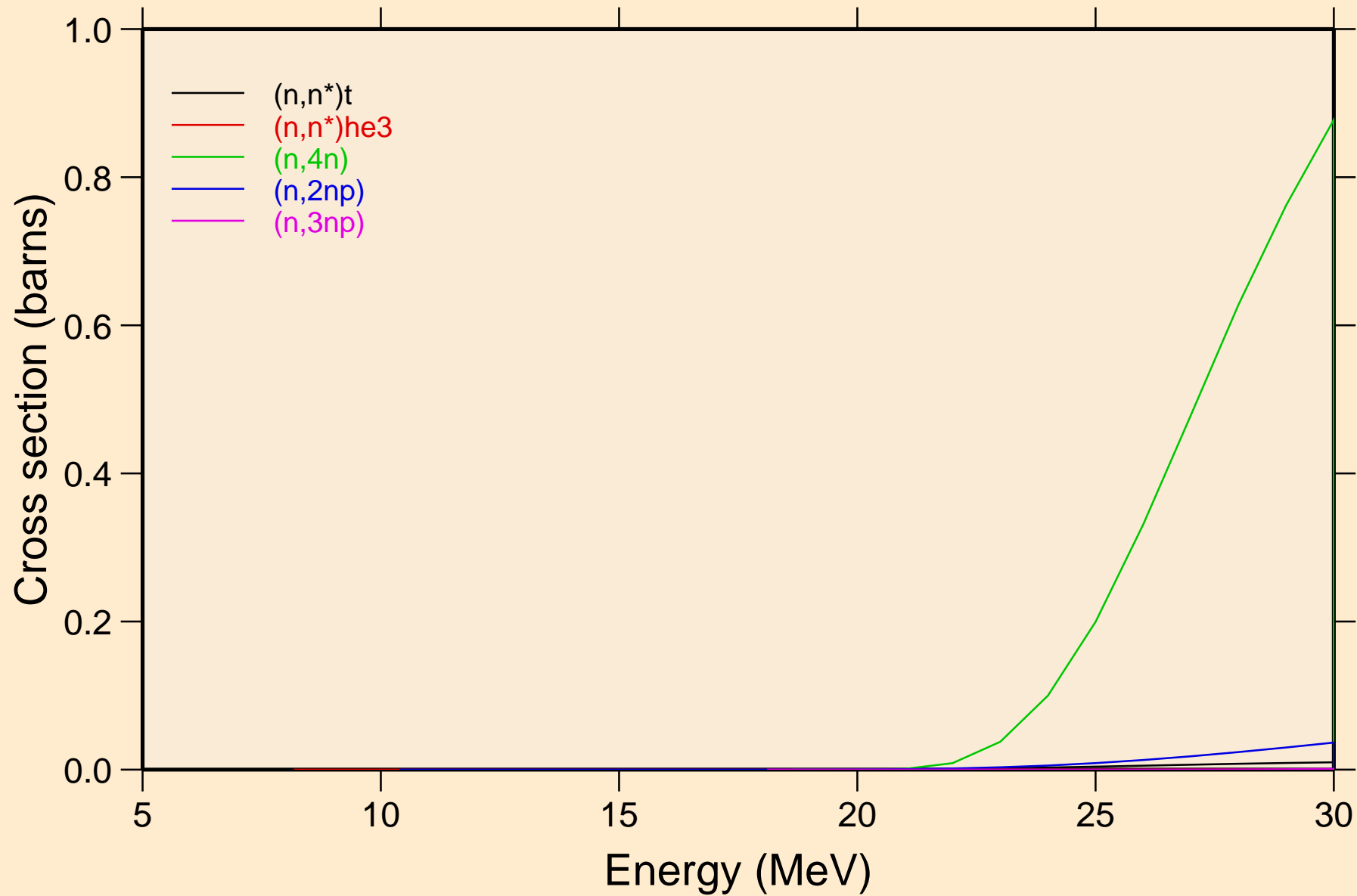

# HF177N NEUTRON ACER TENDL-2024 LIBRARY; T=293.6K

## Threshold reactions

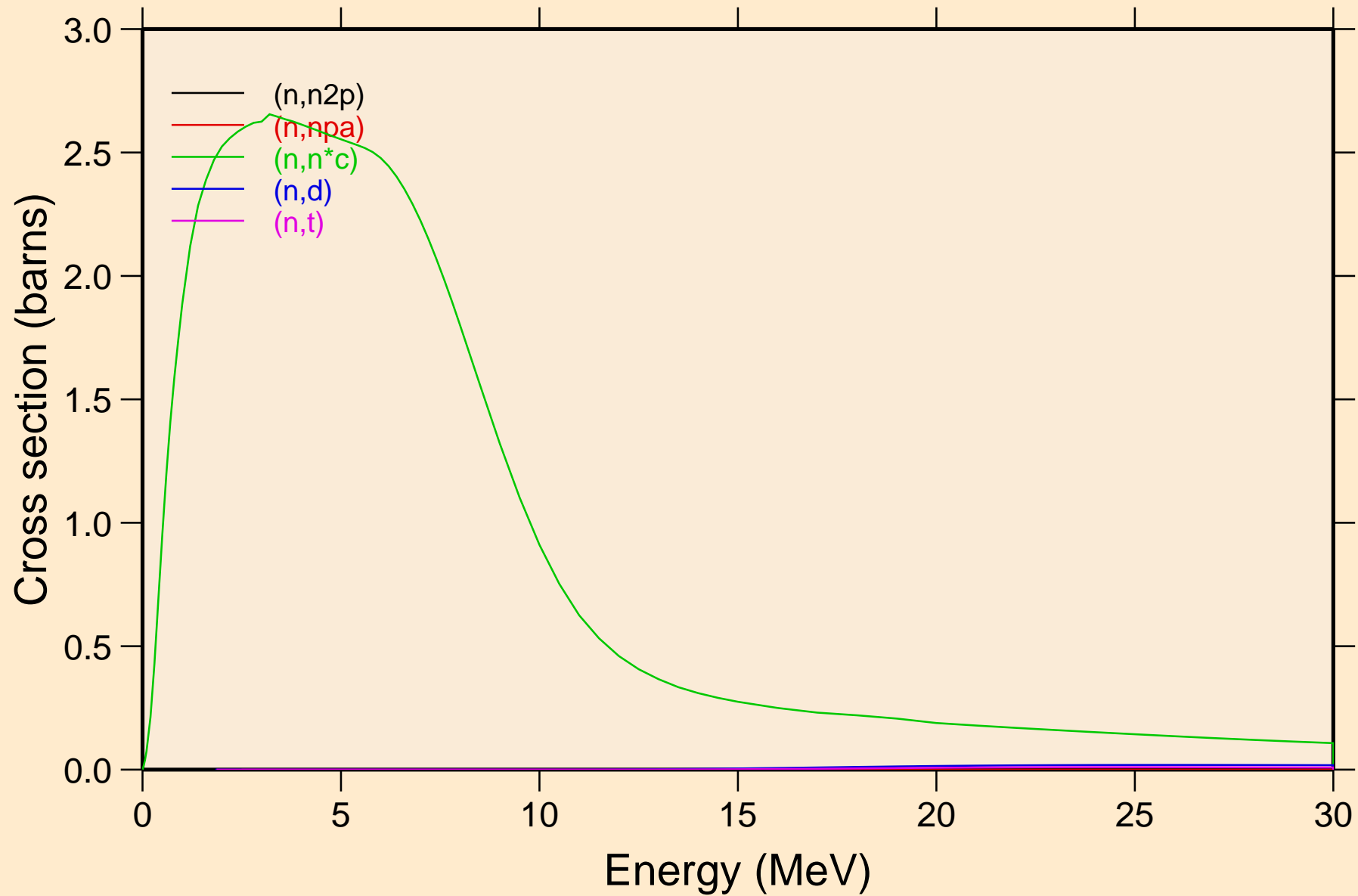

# HF177N NEUTRON ACER TENDL-2024 LIBRARY; T=293.6K

## Threshold reactions

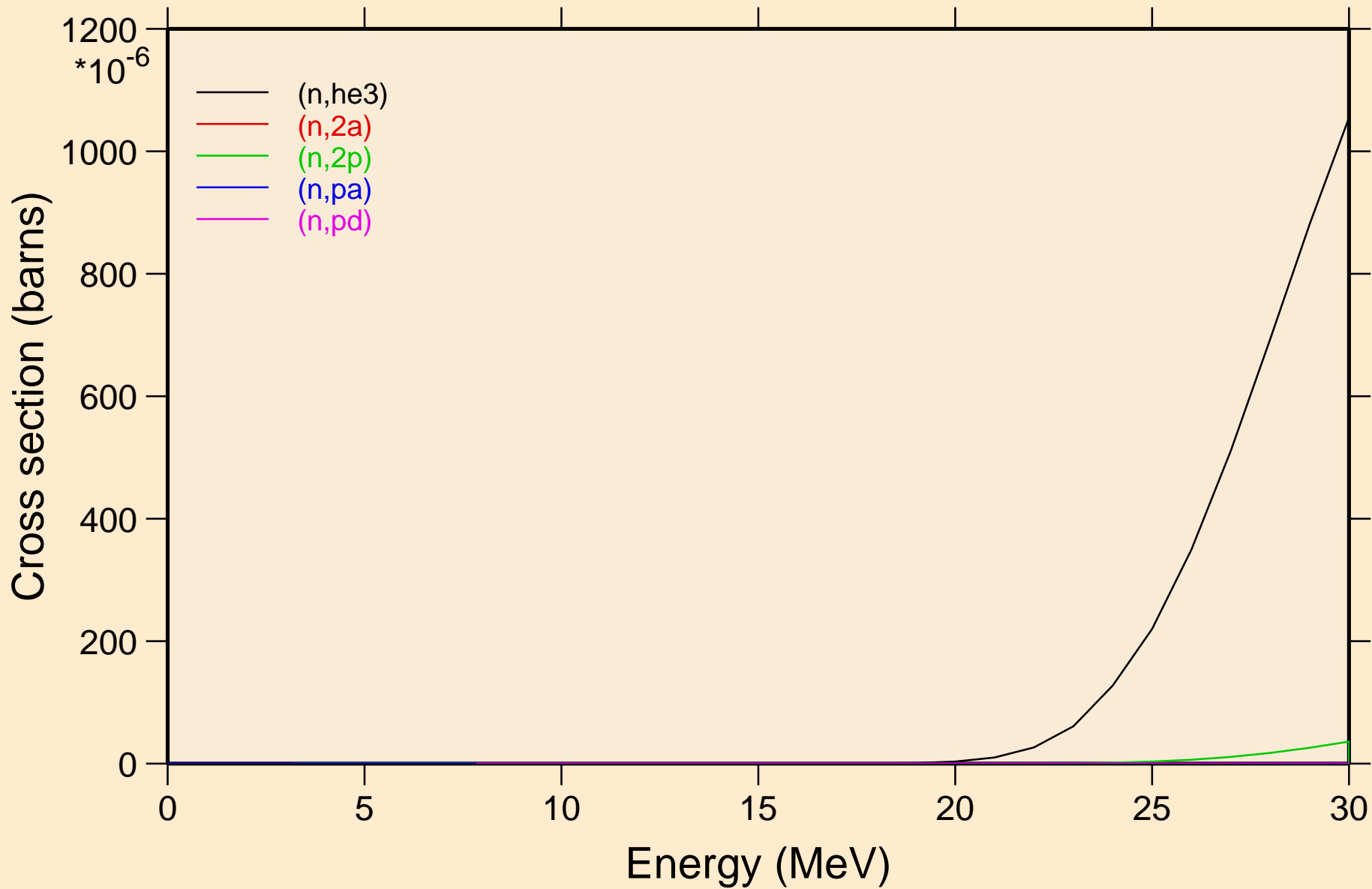

HF177N NEUTRON ACER TENDL-2024 LIBRARY; T=293.6K  
Threshold reactions

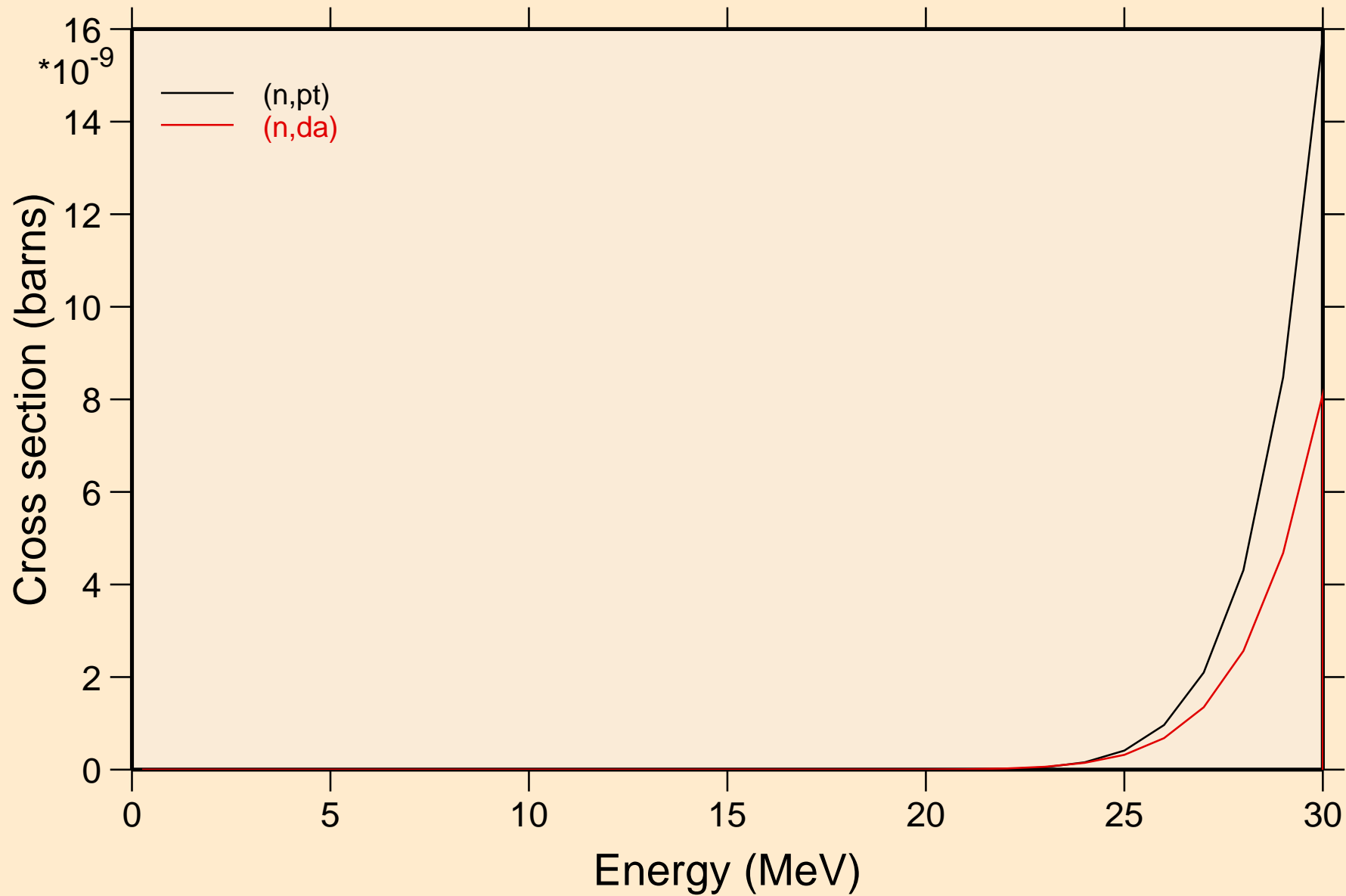

# HF177N NEUTRON ACER TENDL-2024 LIBRARY; T=293.6K

## Threshold reactions

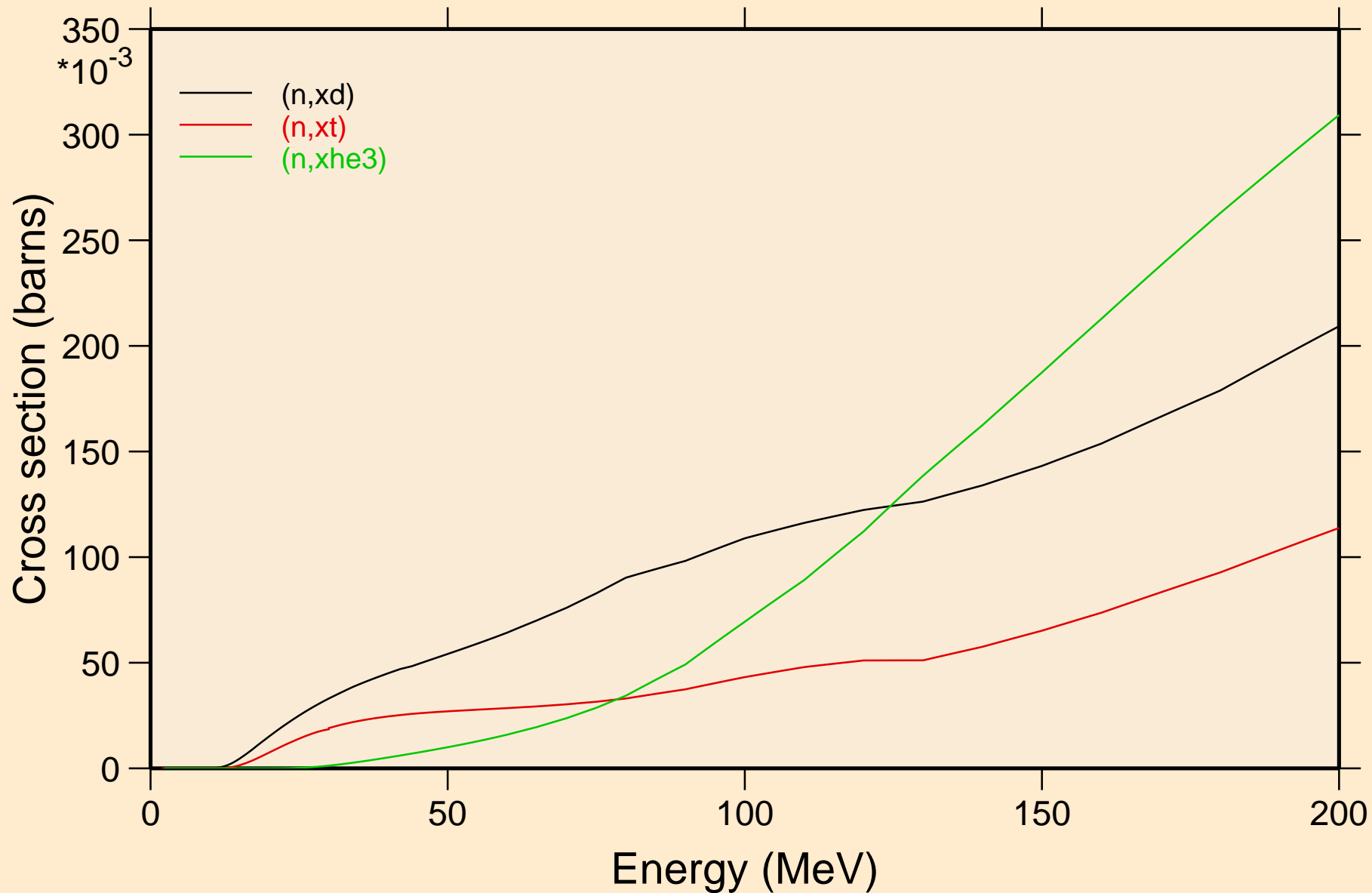

HF177N NEUTRON ACER TENDL-2024 LIBRARY; T=293.6K  
angular distribution for elastic

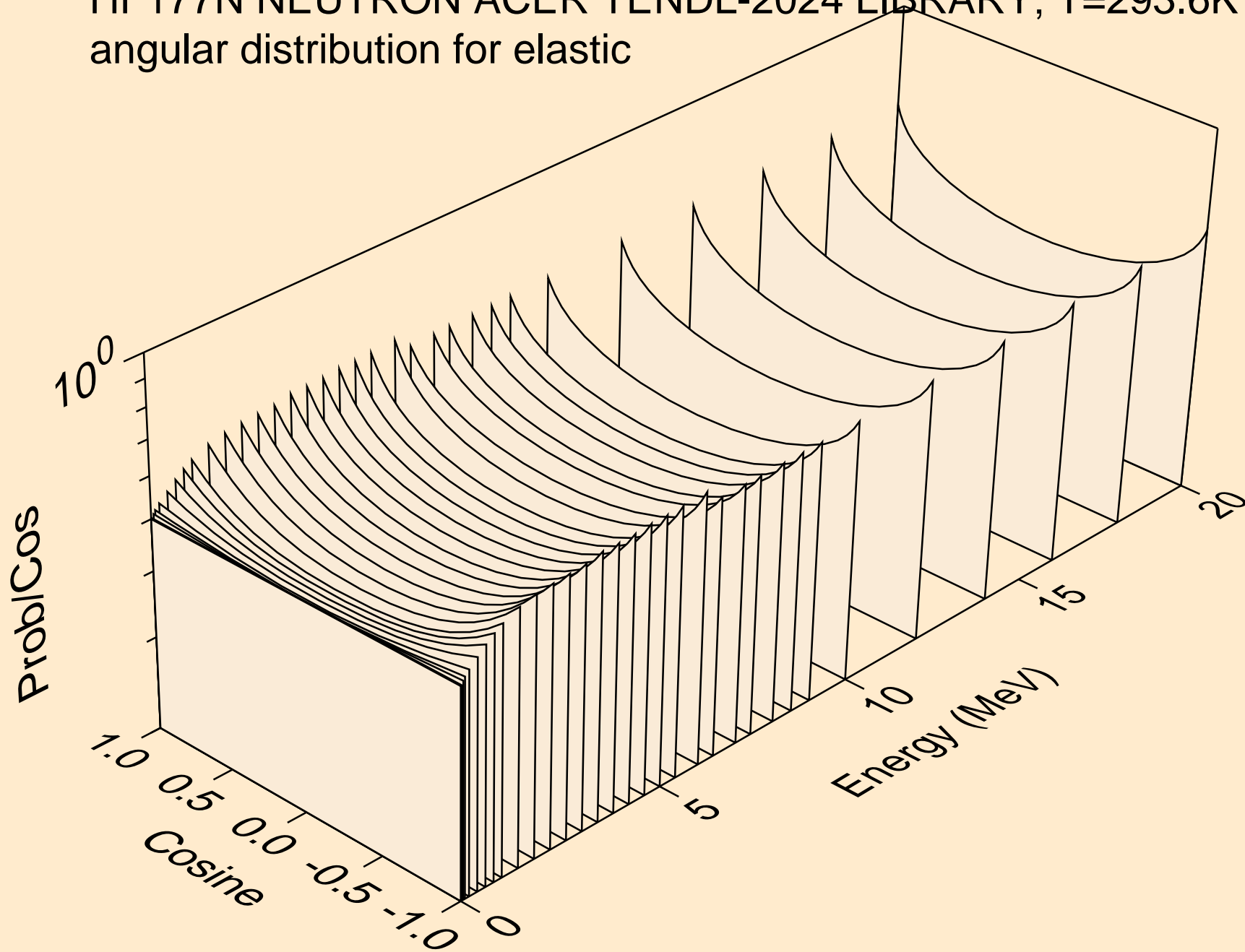

HF177N NEUTRON ACER TENDL-2024 LIBRARY; T=293.6K  
angular distribution for elastic

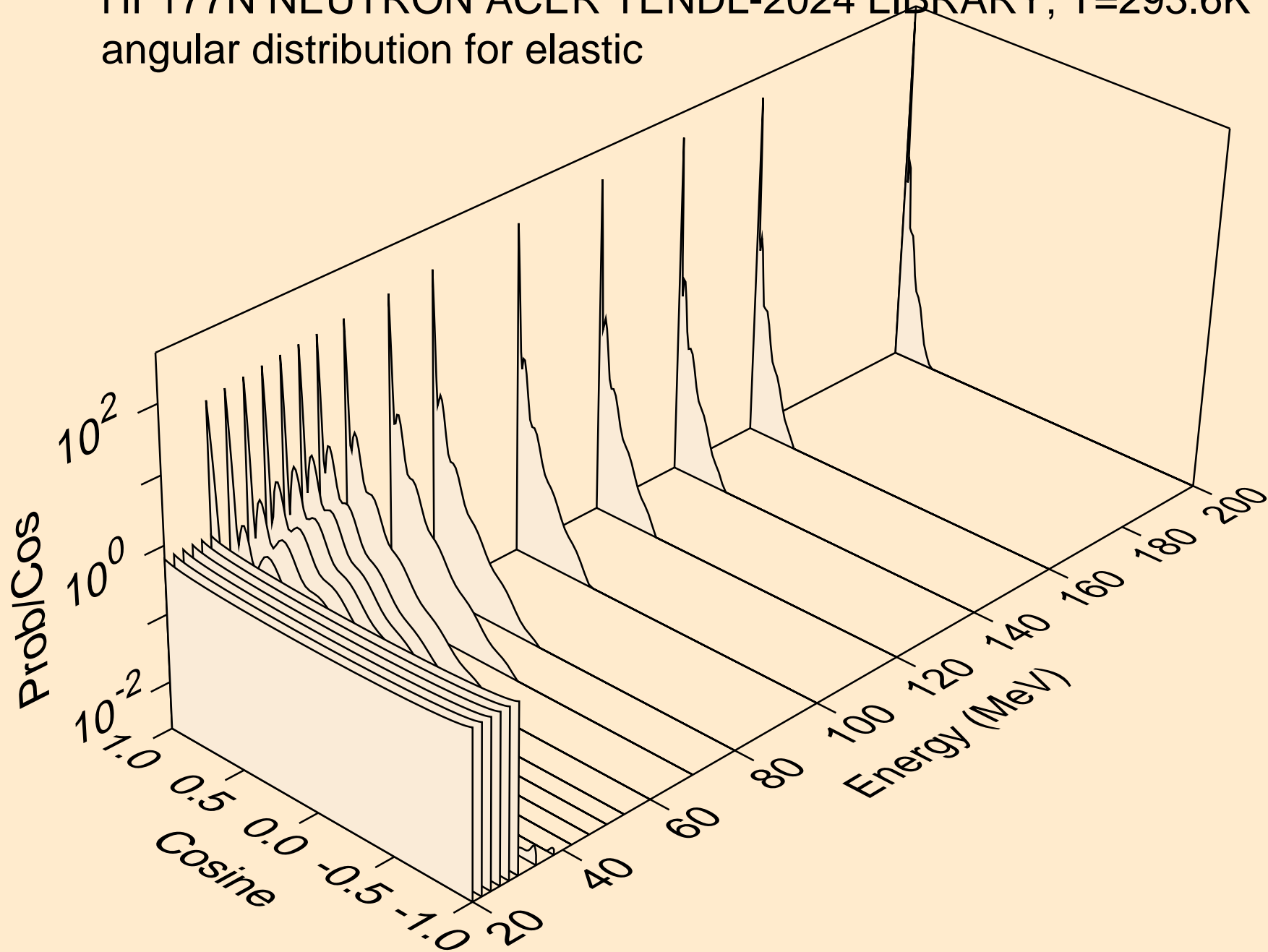

HF177N NEUTRON ACER TENDL-2024 LIBRARY; T=293.6K  
angular distribution for (n,n\*1)

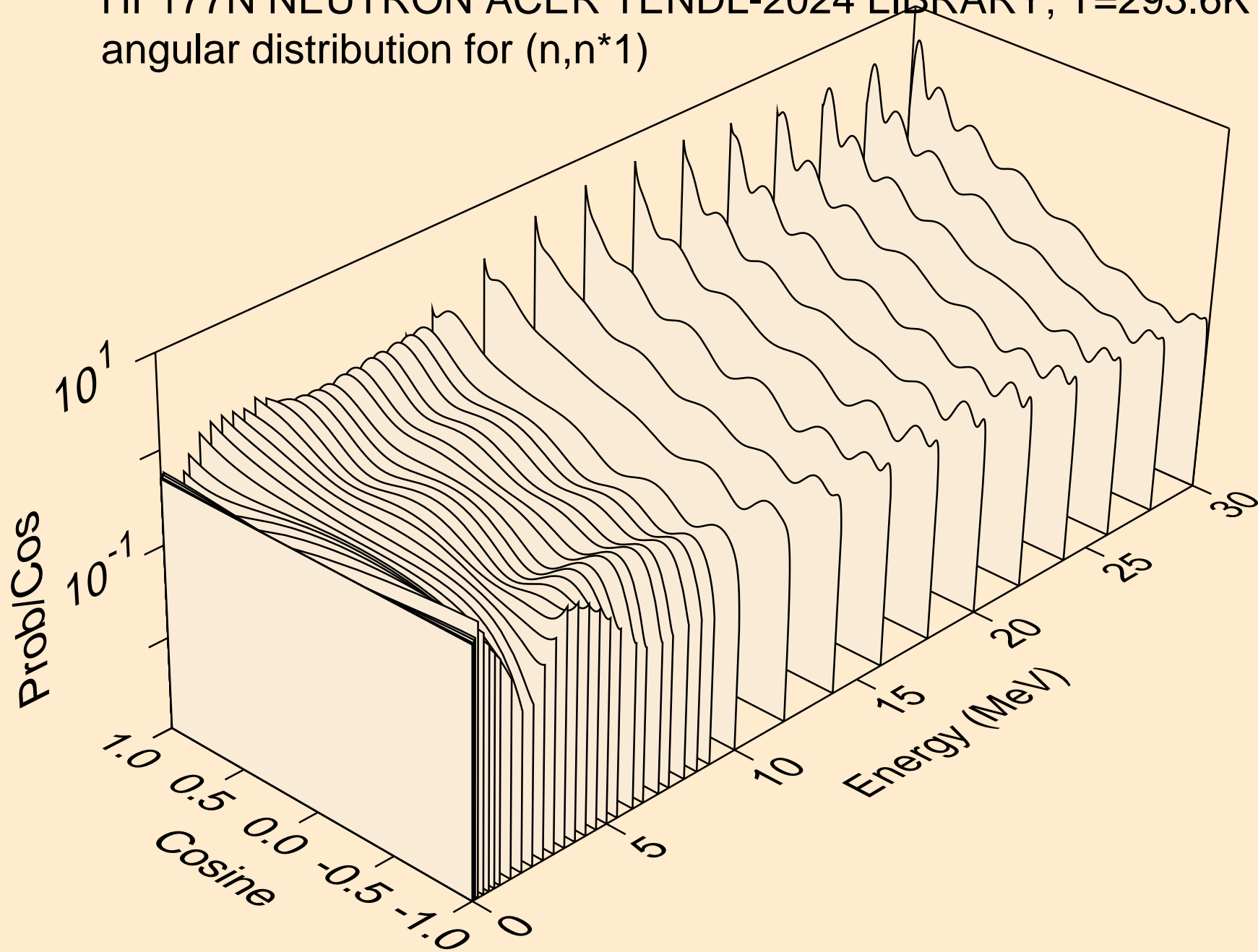

HF177N NEUTRON ACER TENDL-2024 LIBRARY; T=293.6K  
angular distribution for (n,n\*2)

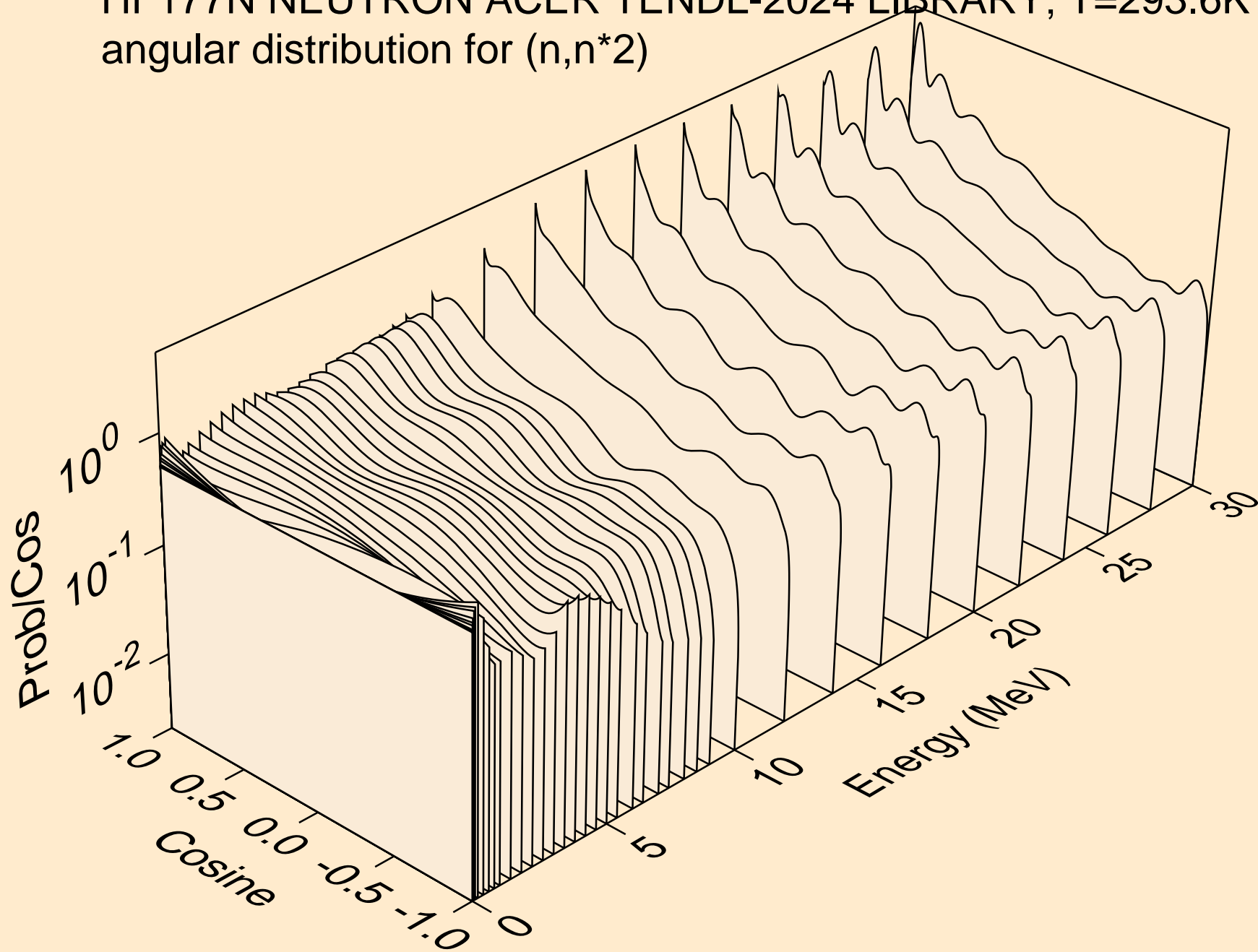

HF177N NEUTRON ACER TENDL-2024 LIBRARY; T=293.6K  
angular distribution for (n,n\*3)

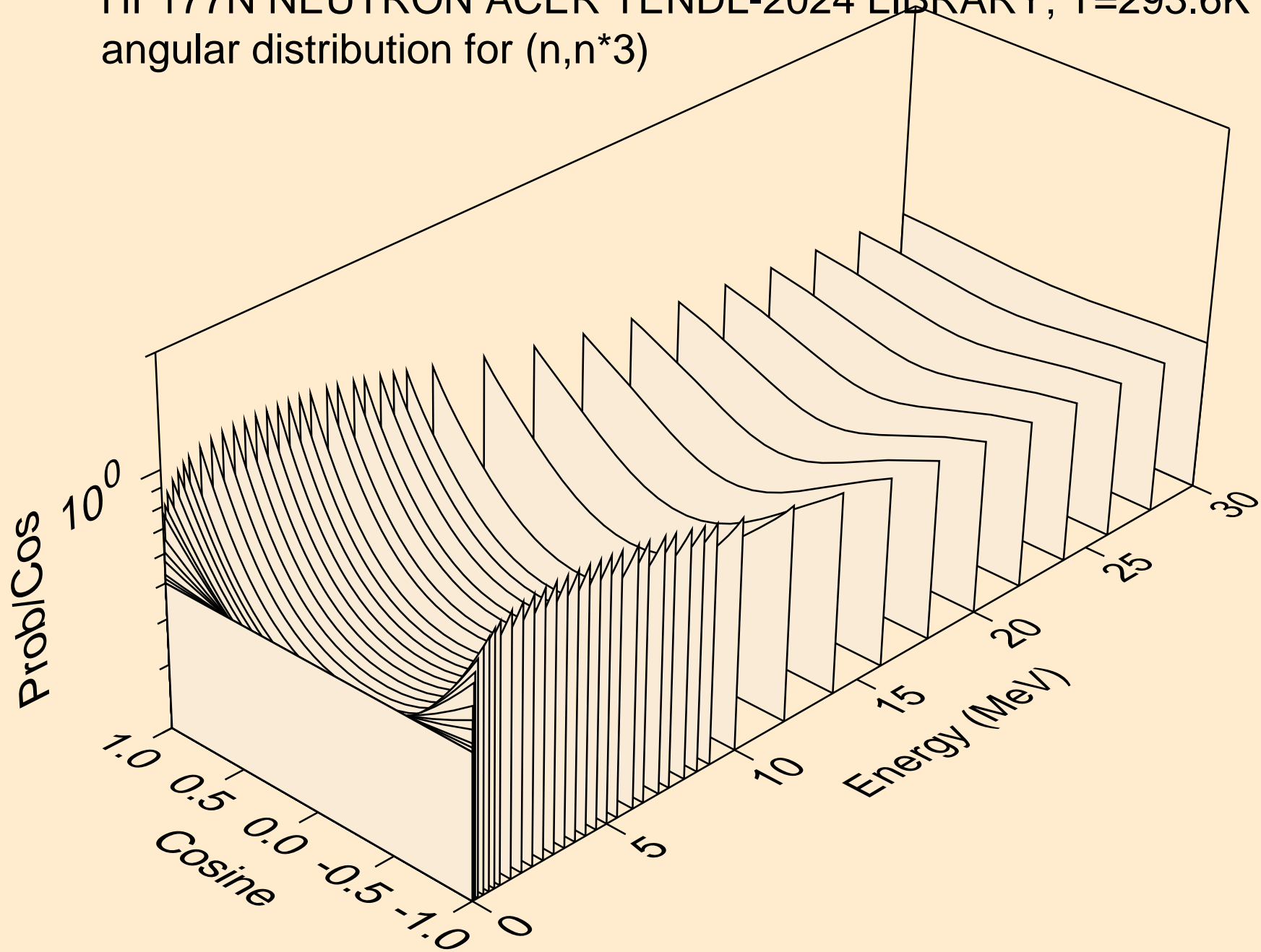

HF177N NEUTRON ACER TENDL-2024 LIBRARY; T=293.6K  
angular distribution for (n,n\*4)

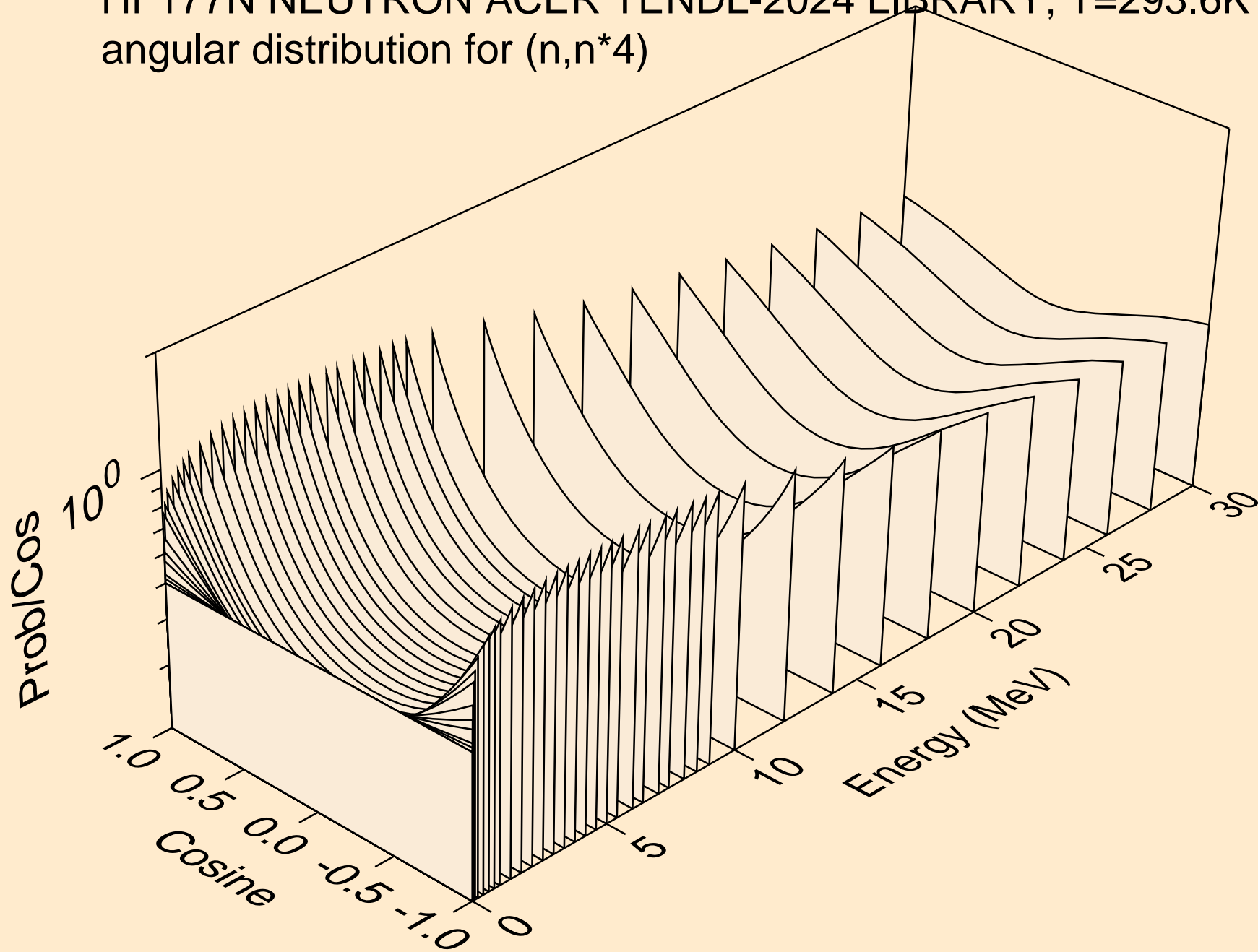

HF177N NEUTRON ACER TENDL-2024 LIBRARY; T=293.6K  
angular distribution for (n,n\*5)

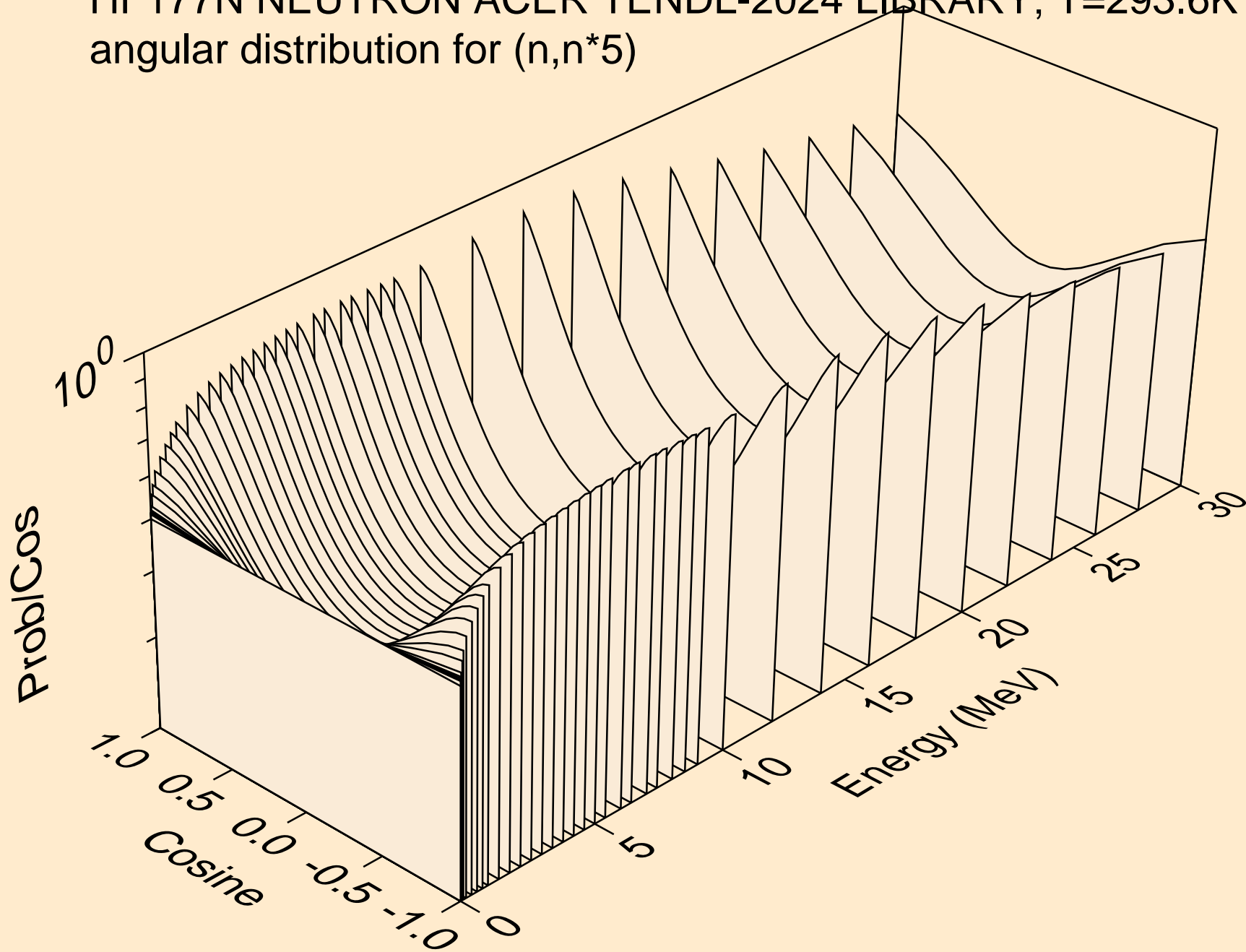

HF177N NEUTRON ACER TENDL-2024 LIBRARY; T=293.6K  
angular distribution for (n,n\*6)

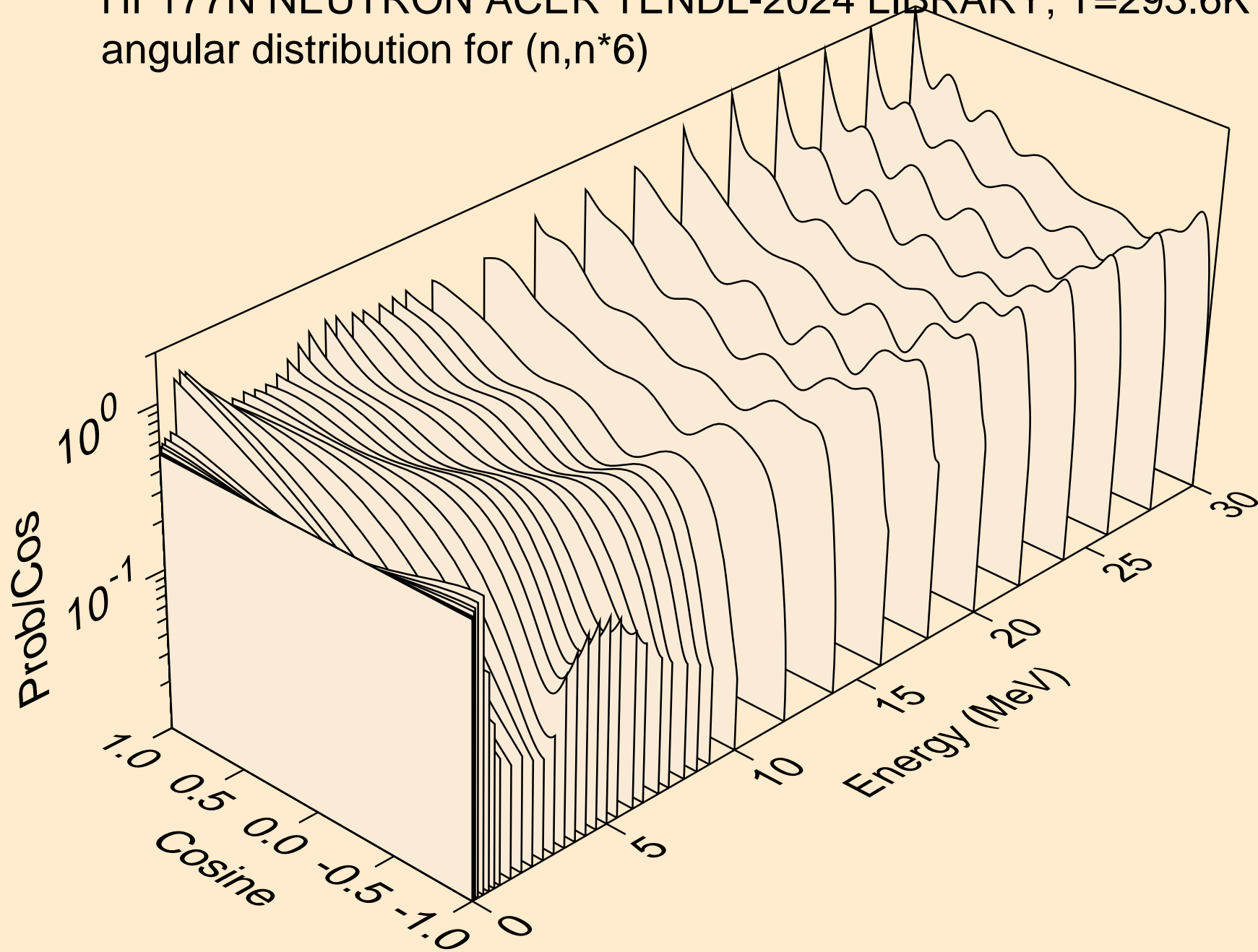

HF177N NEUTRON ACER TENDL-2024 LIBRARY; T=293.6K  
angular distribution for (n,n\*7)

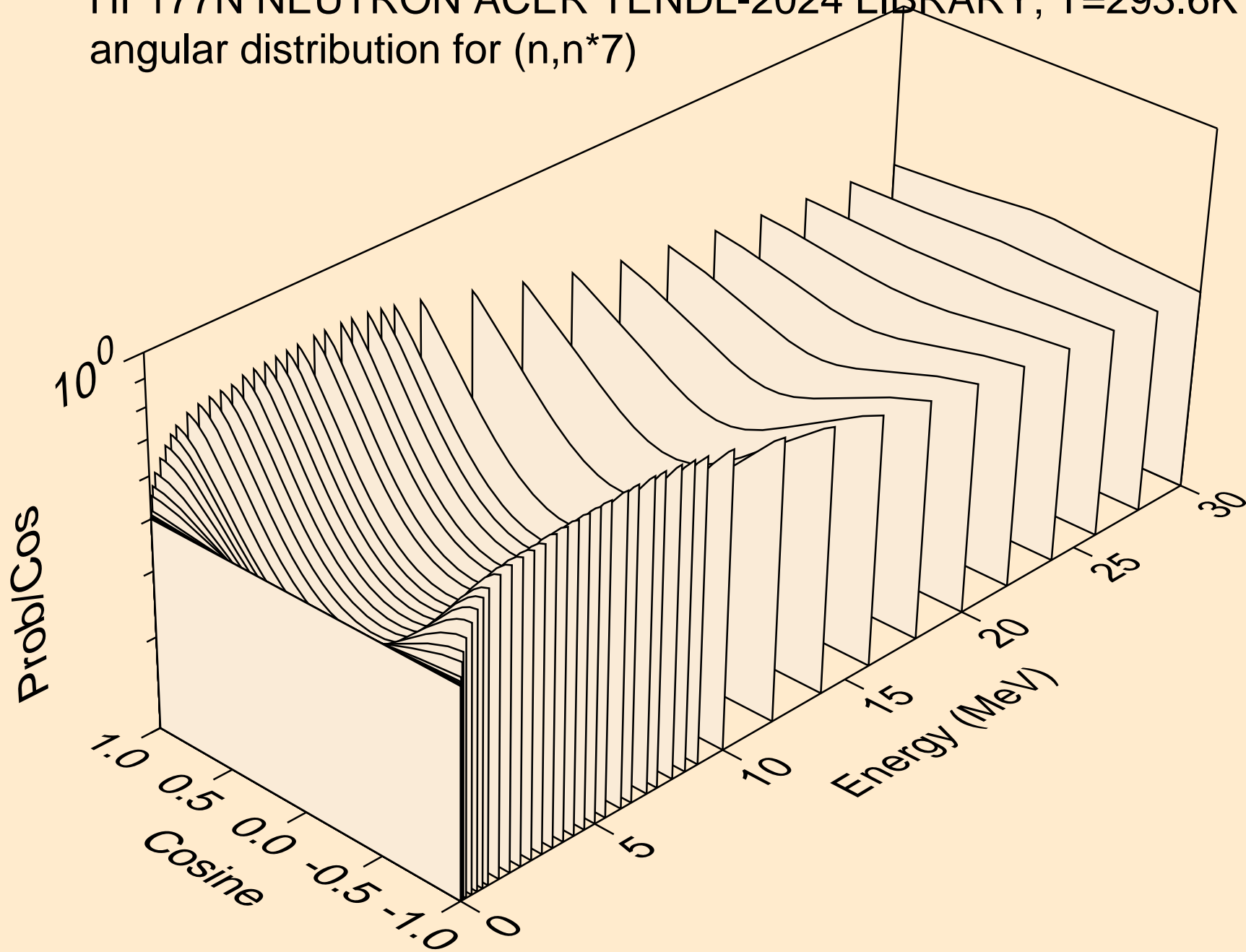

HF177N NEUTRON ACER TENDL-2024 LIBRARY; T=293.6K  
angular distribution for (n,n\*8)

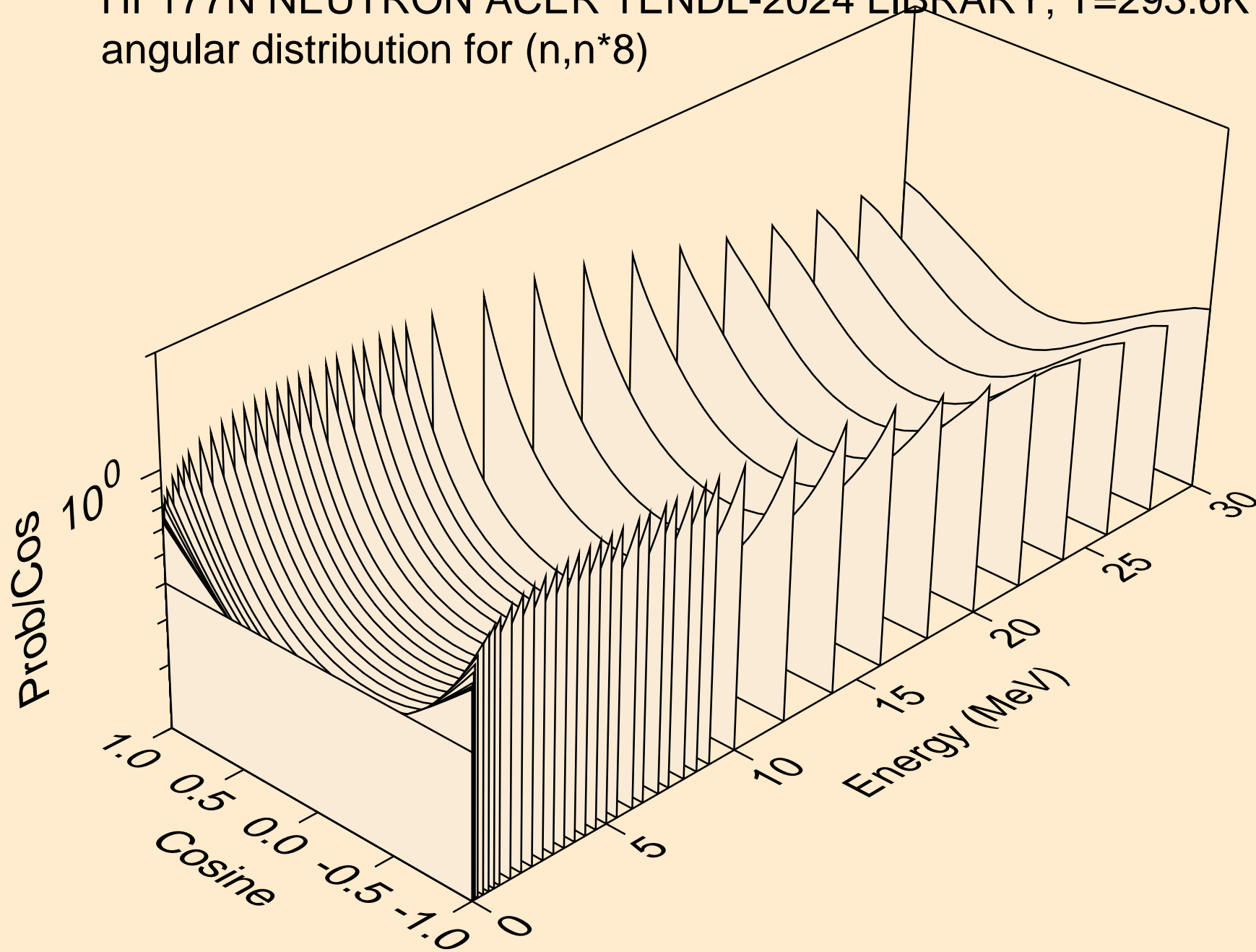

HF177N NEUTRON ACER TENDL-2024 LIBRARY; T=293.6K  
angular distribution for (n,n\*9)

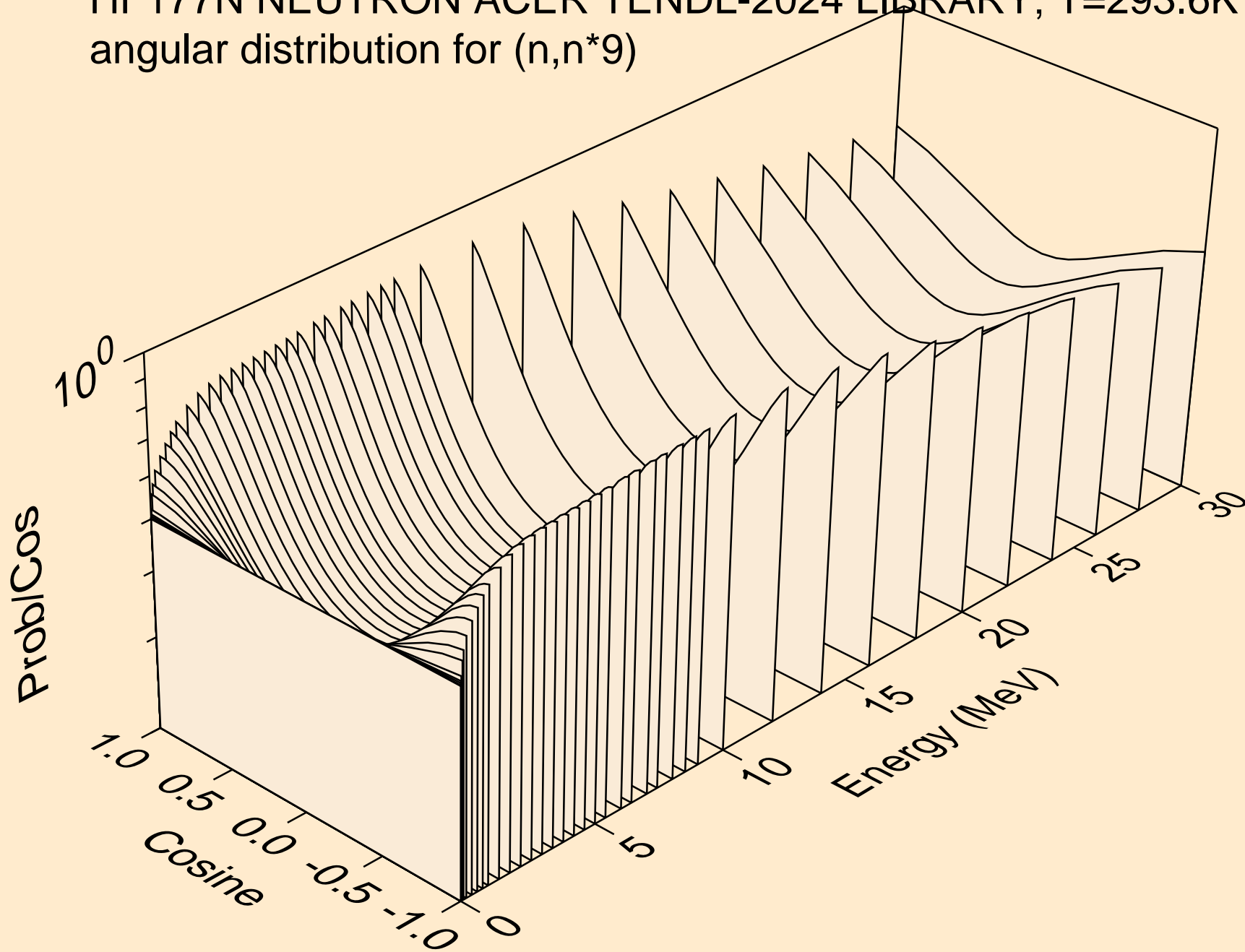

HF177N NEUTRON ACER TENDL-2024 LIBRARY; T=293.6K  
angular distribution for (n,n\*10)

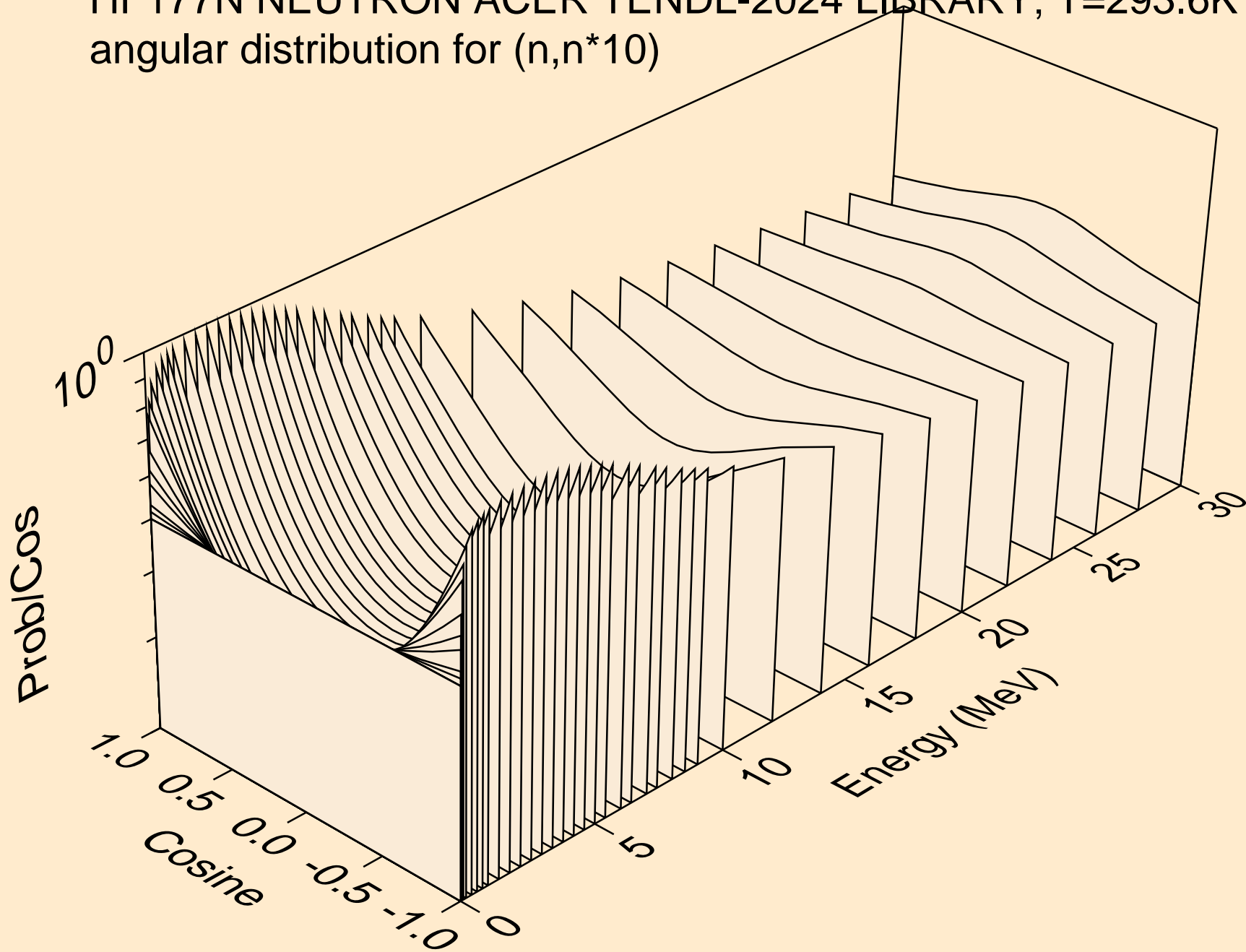

HF177N NEUTRON ACER TENDL-2024 LIBRARY; T=293.6K  
angular distribution for (n,n\*11)

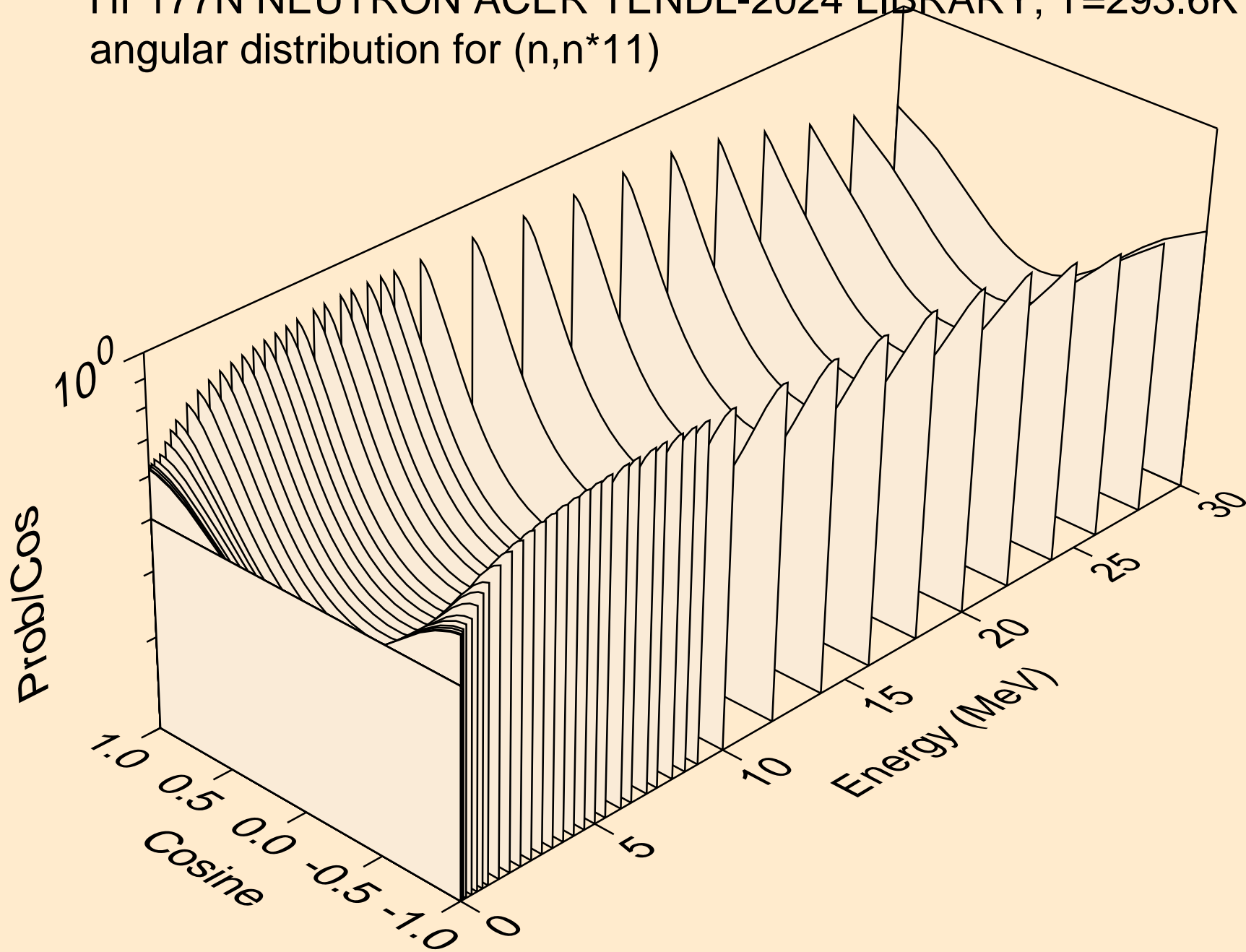

HF177N NEUTRON ACER TENDL-2024 LIBRARY; T=293.6K  
angular distribution for (n,n\*12)

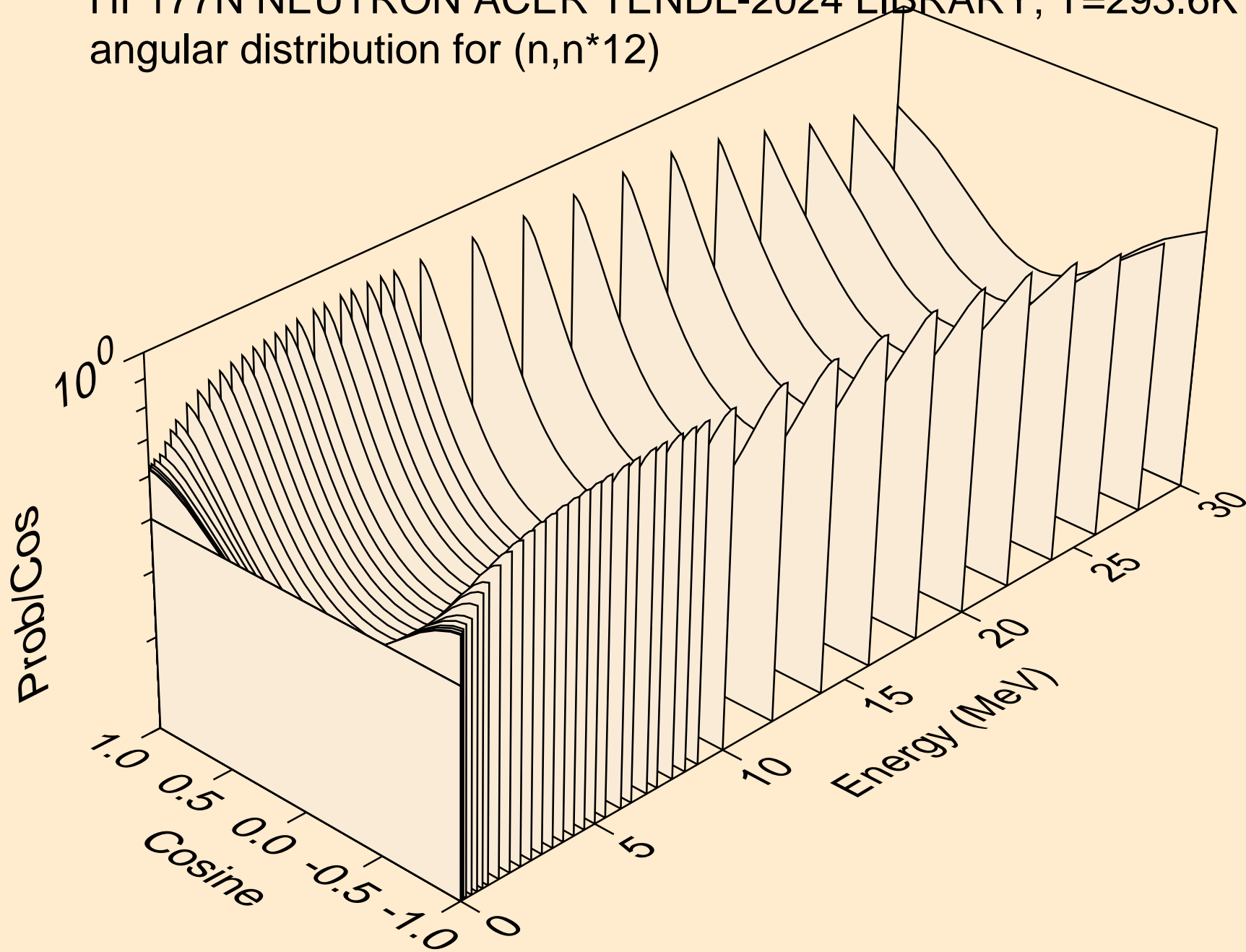

HF177N NEUTRON ACER TENDL-2024 LIBRARY; T=293.6K  
angular distribution for (n,n\*13)

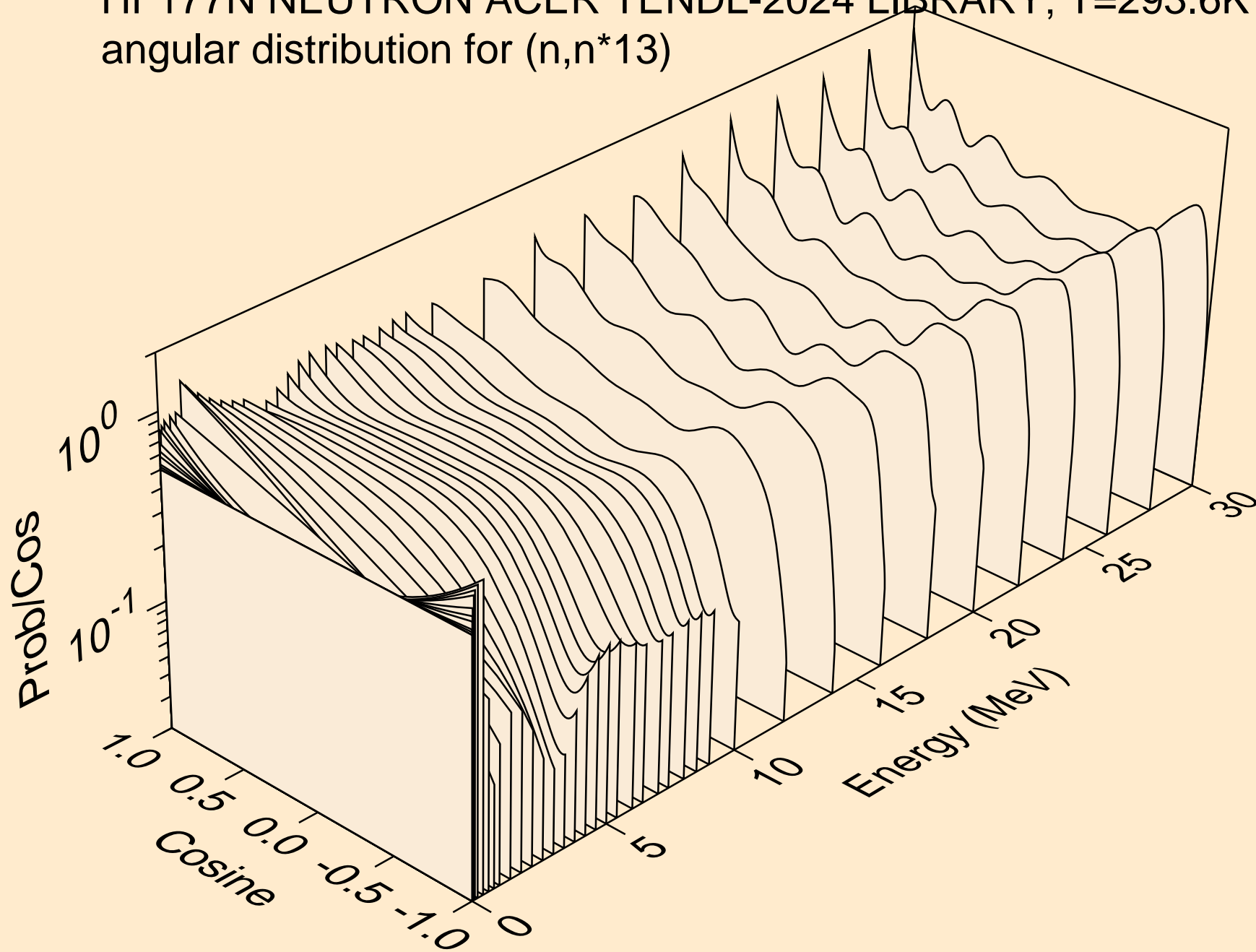

HF177N NEUTRON ACER TENDL-2024 LIBRARY; T=293.6K  
angular distribution for (n,n\*14)

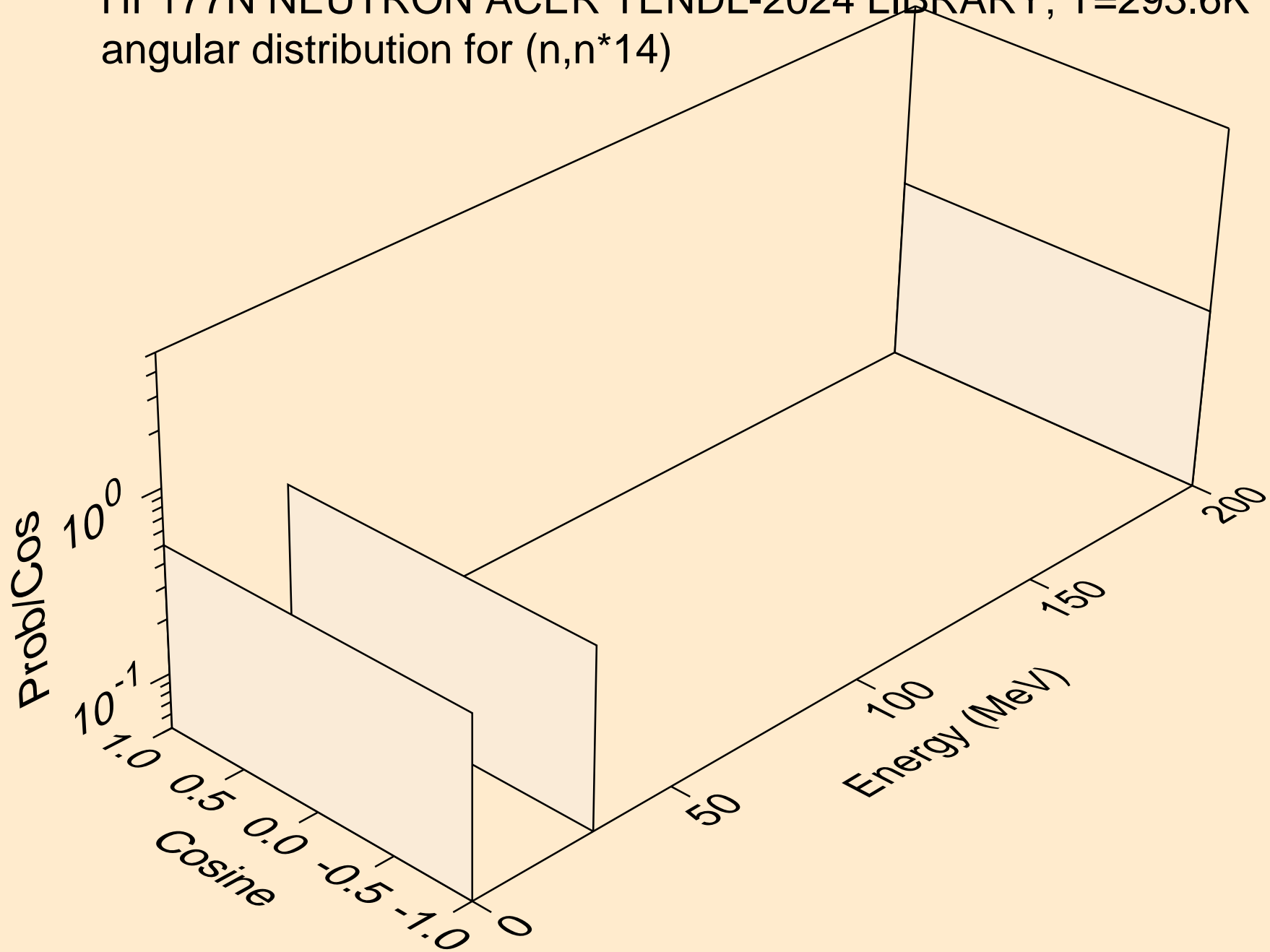

HF177N NEUTRON ACER TENDL-2024 LIBRARY; T=293.6K  
Neutron emission for (n,x)

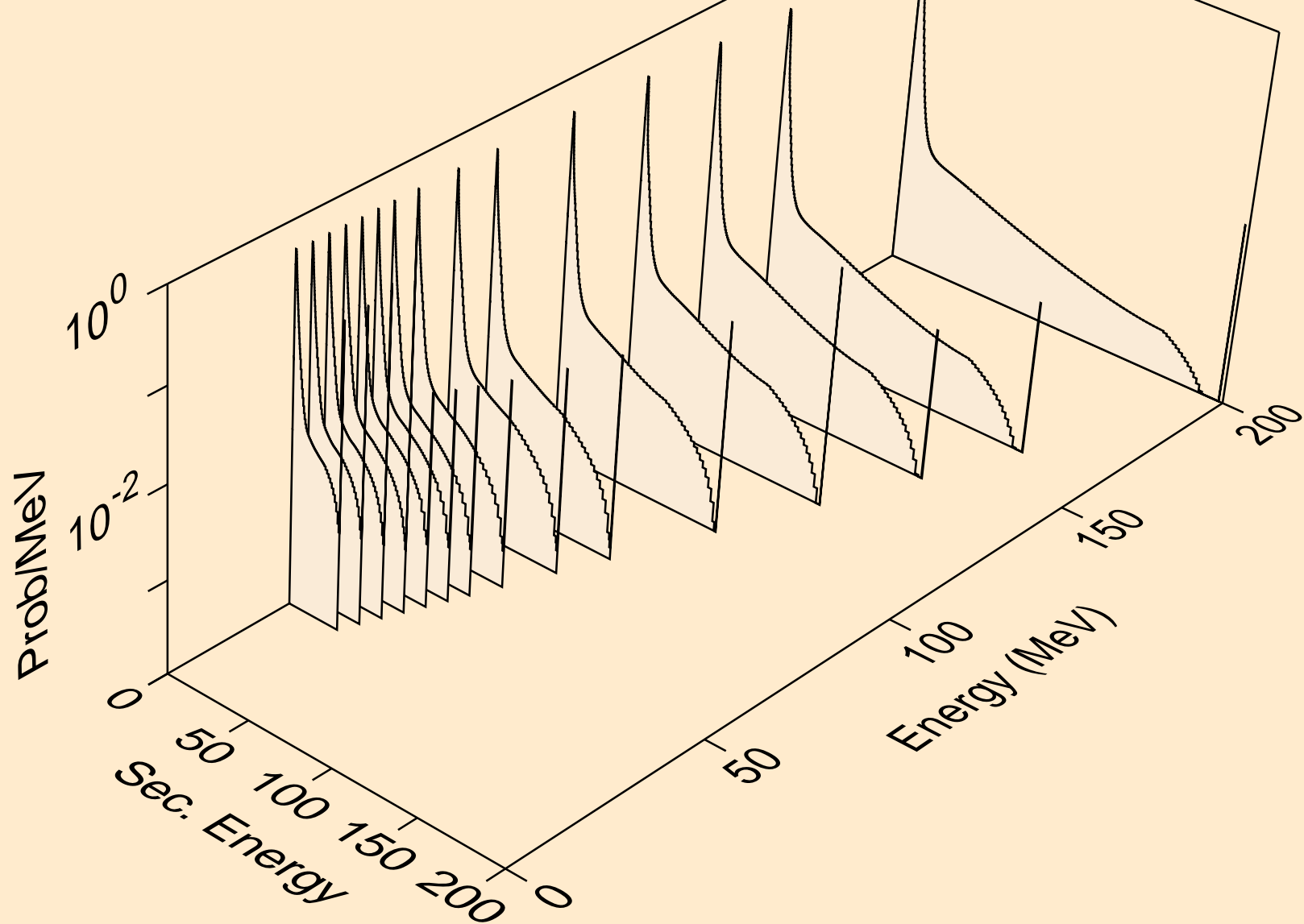

HF177N NEUTRON ACER TENDL-2024 LIBRARY; T=293.6K  
Neutron emission for (n,2nd)

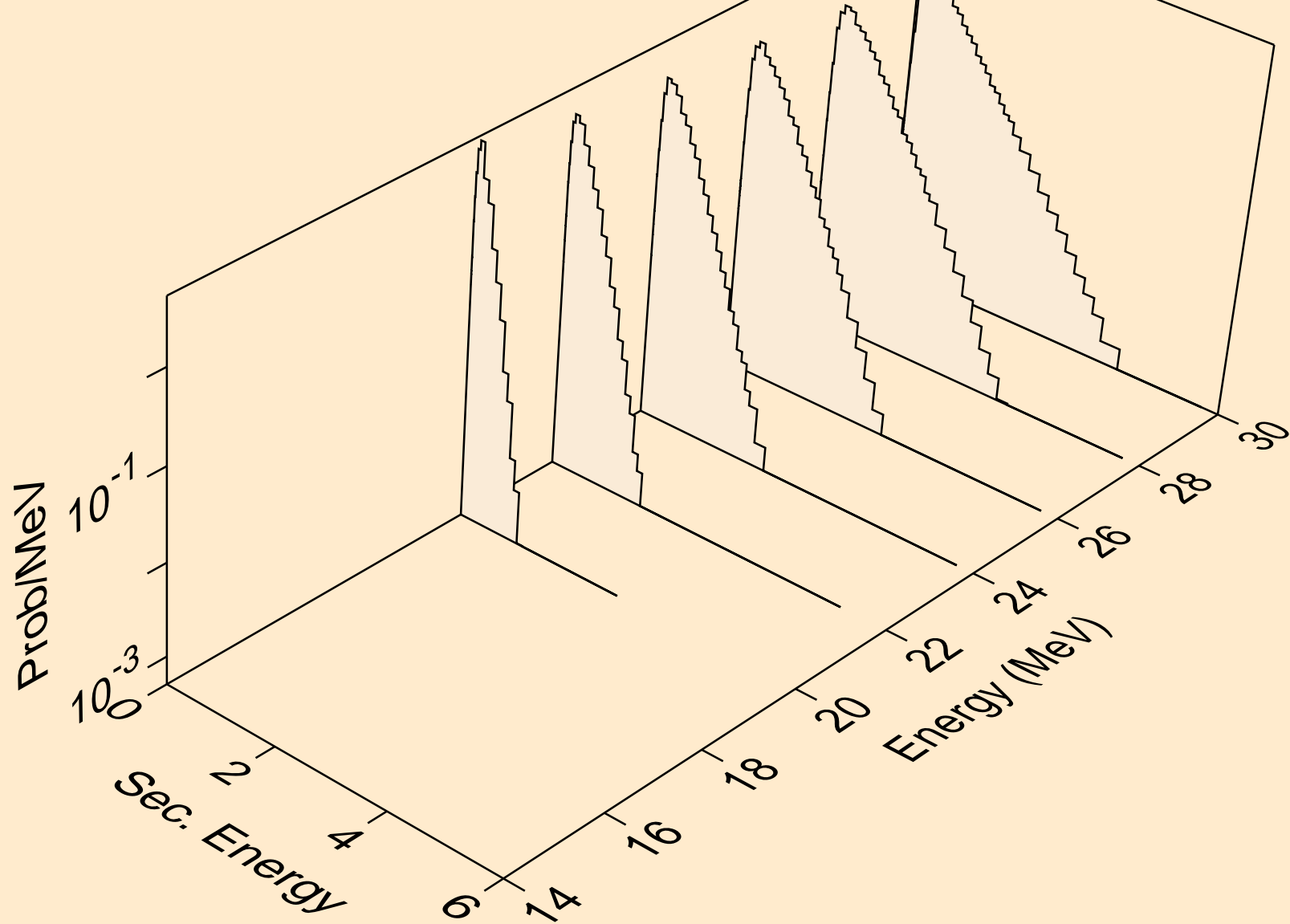

HF177N NEUTRON ACER TENDL-2024 LIBRARY; T=293.6K  
Neutron emission for (n,2n)

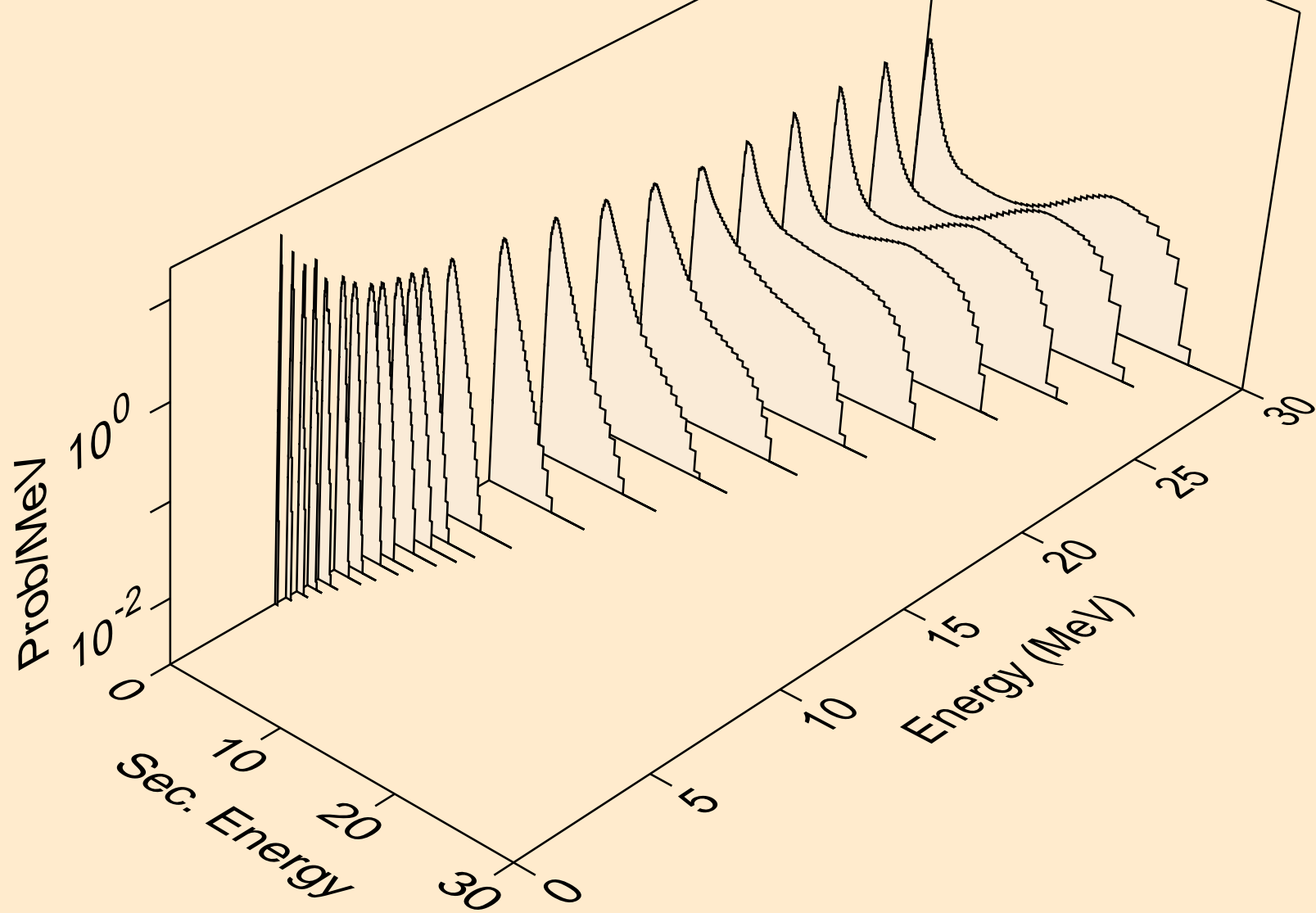

HF177N NEUTRON ACER TENDL-2024 LIBRARY; T=293.6K  
Neutron emission for (n,3n)

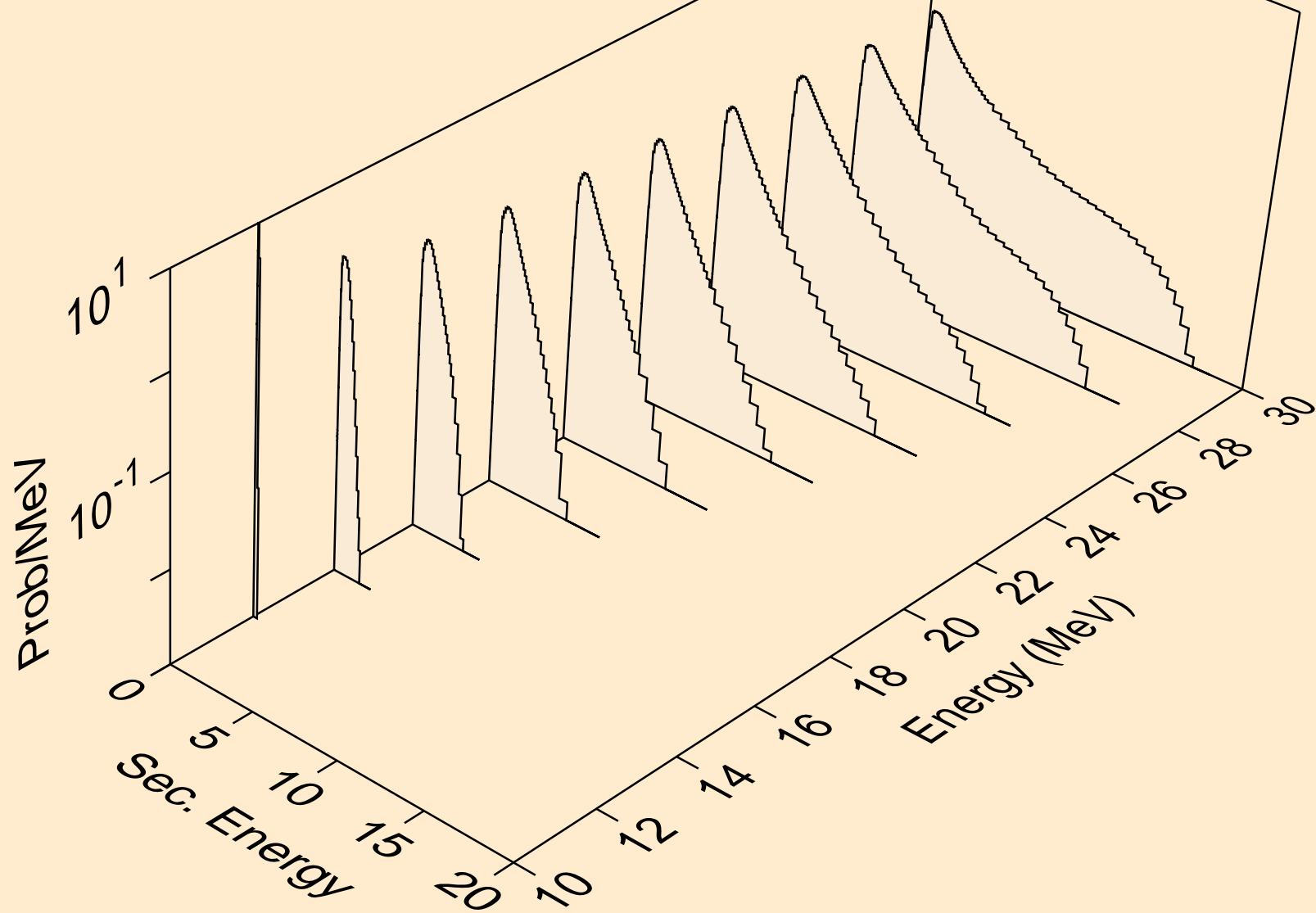

HF177N NEUTRON ACER TENDL-2024 LIBRARY; T=293.6K  
Neutron emission for (n,n\*)a

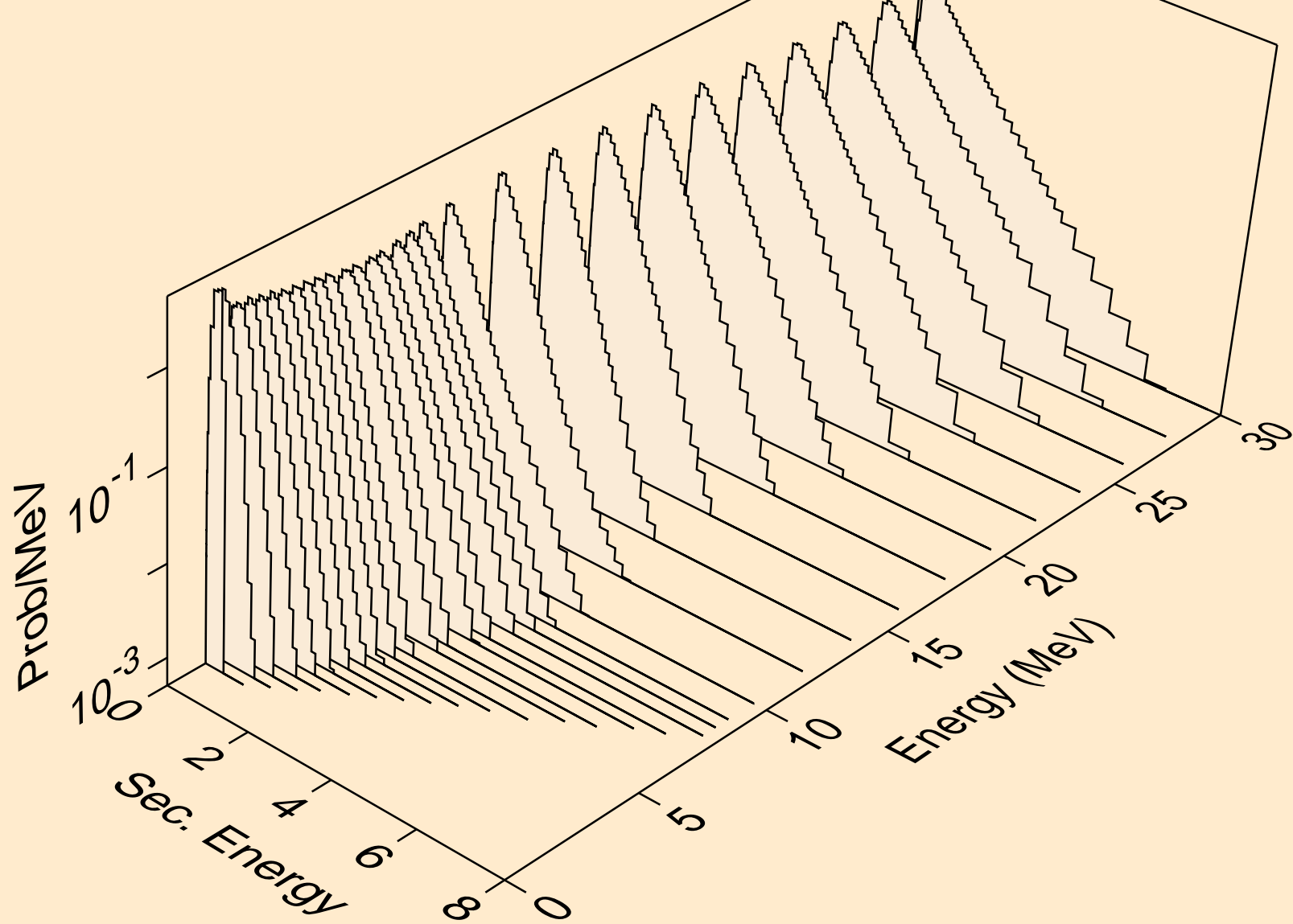

HF177N NEUTRON ACER TENDL-2024 LIBRARY; T=293.6K  
Neutron emission for (n,2n)a

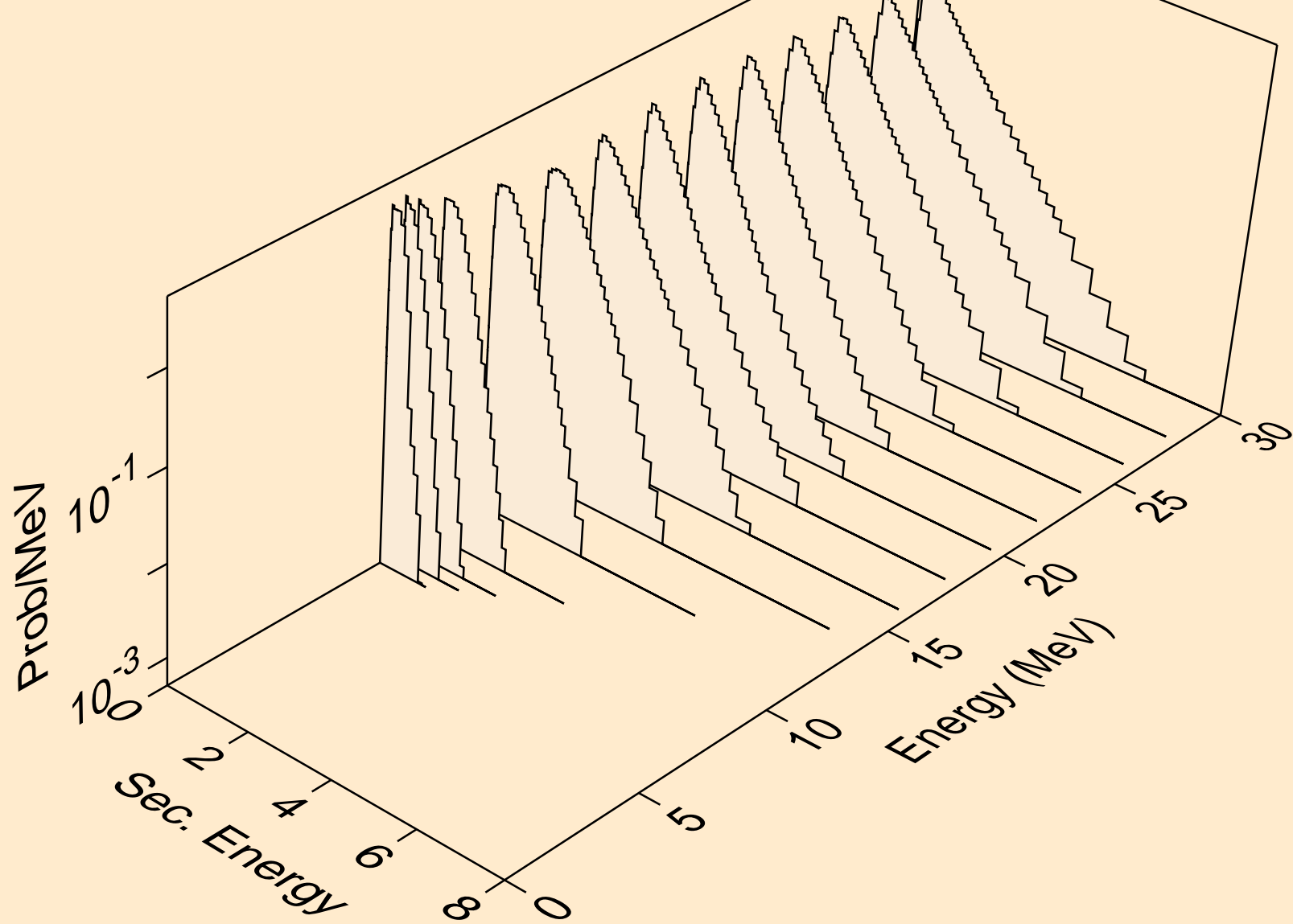

HF177N NEUTRON ACER TENDL-2024 LIBRARY; T=293.6K  
Neutron emission for (n,3n)a

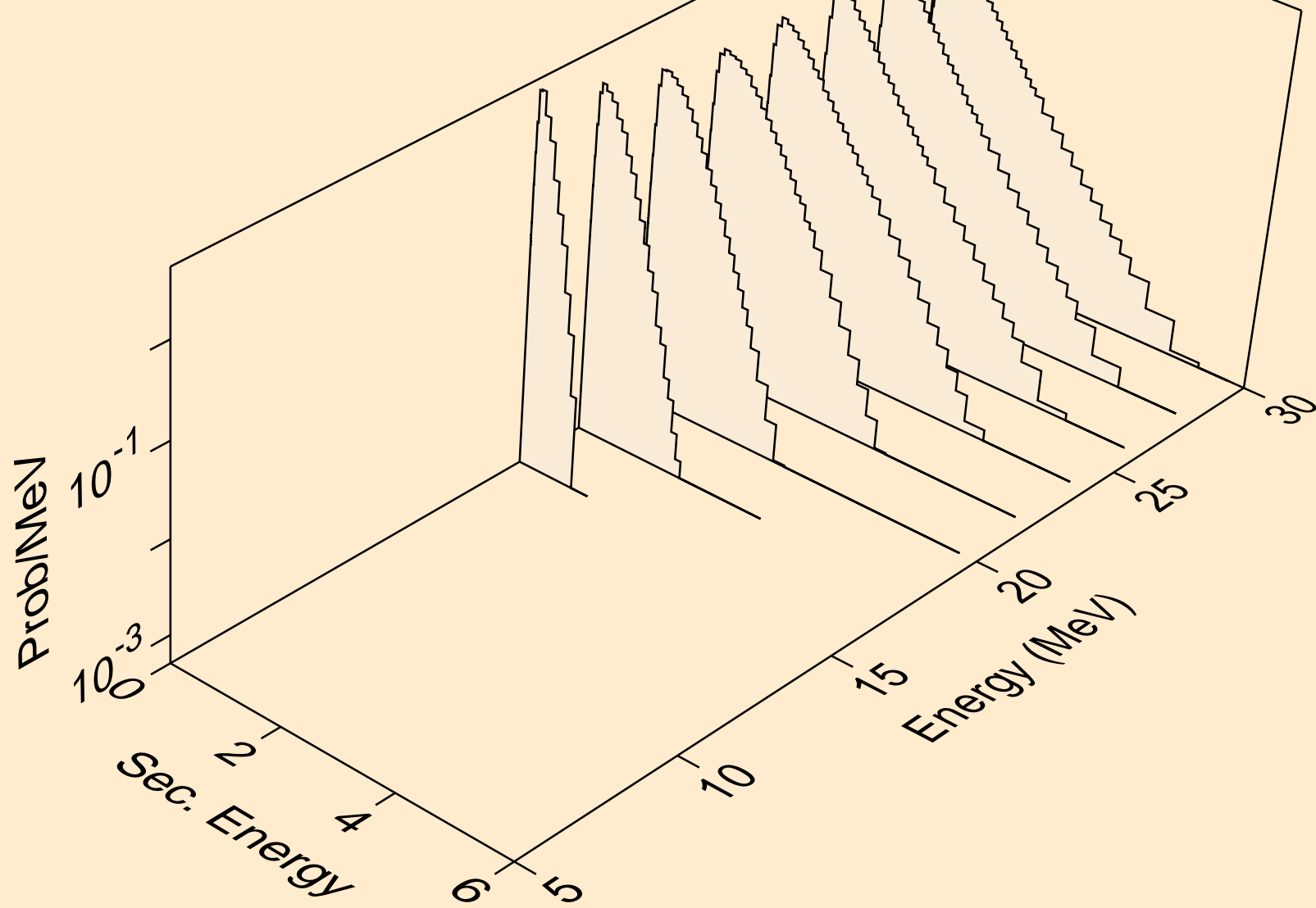

HF177N NEUTRON ACER TENDL-2024 LIBRARY; T=293.6K  
Neutron emission for (n,n\*)p

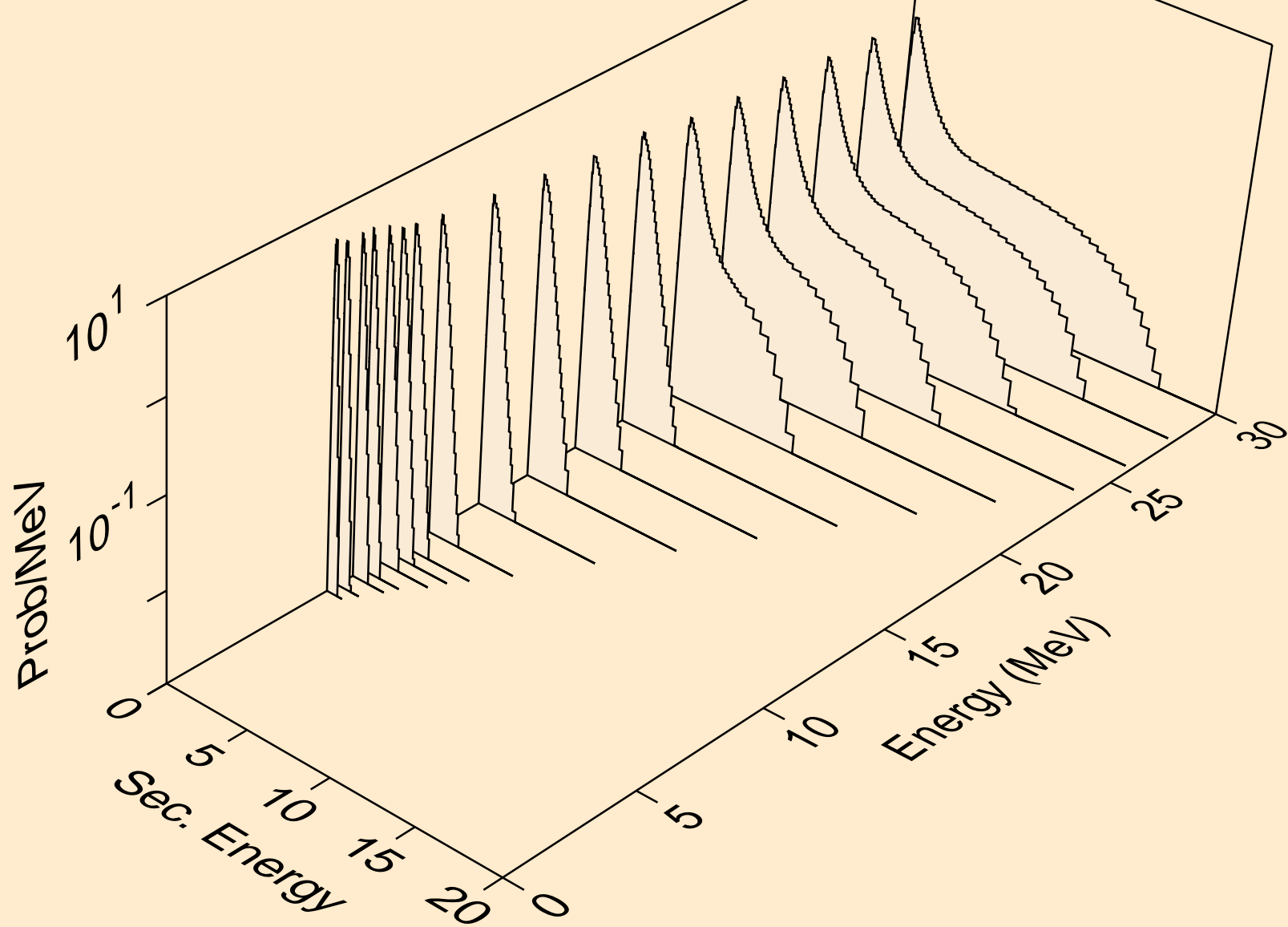

HF177N NEUTRON ACER TENDL-2024 LIBRARY; T=293.6K  
Neutron emission for (n,n\*)2a

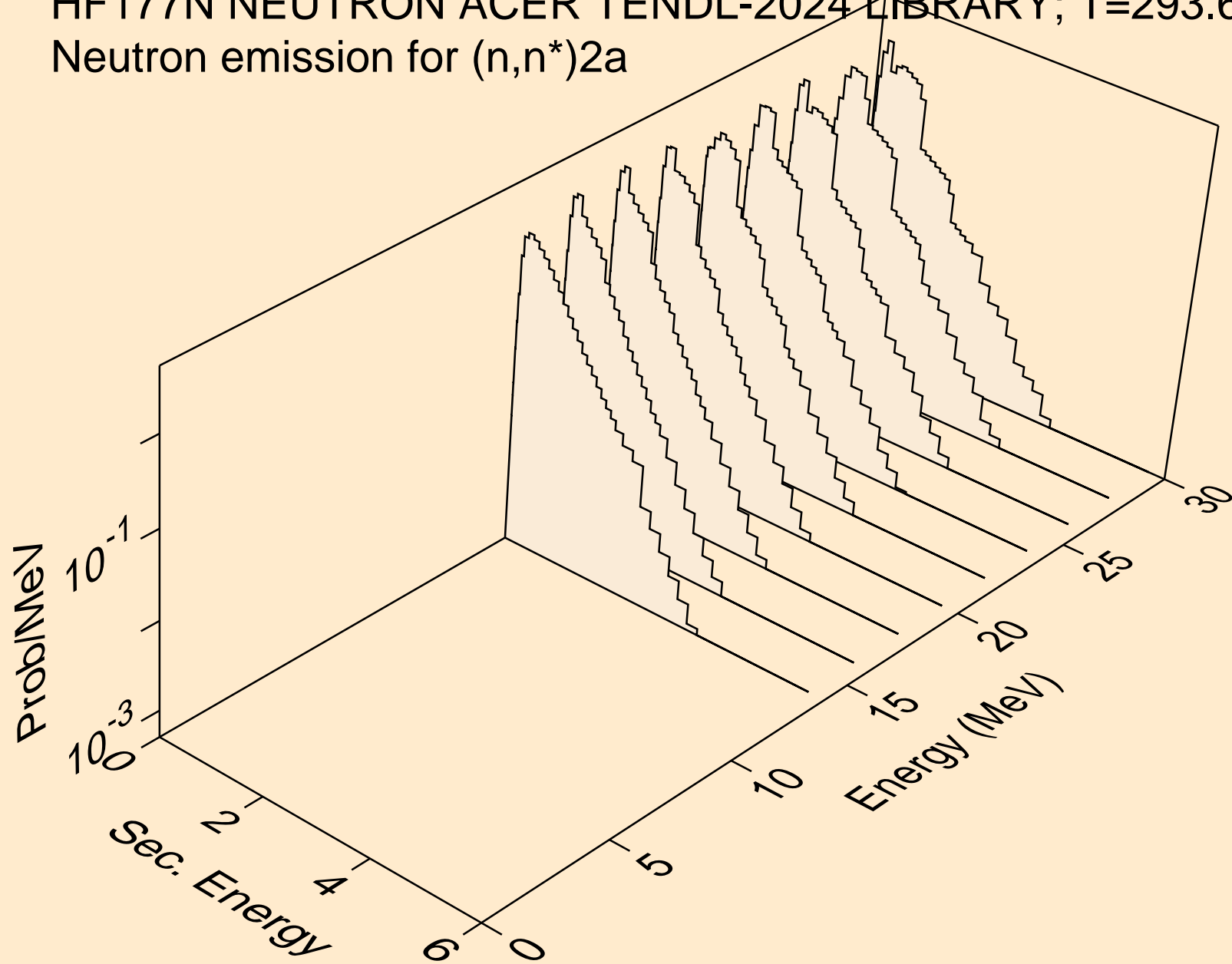

HF177N NEUTRON ACER TENDL-2024 LIBRARY; T=293.6K  
Neutron emission for (n,n\*)d

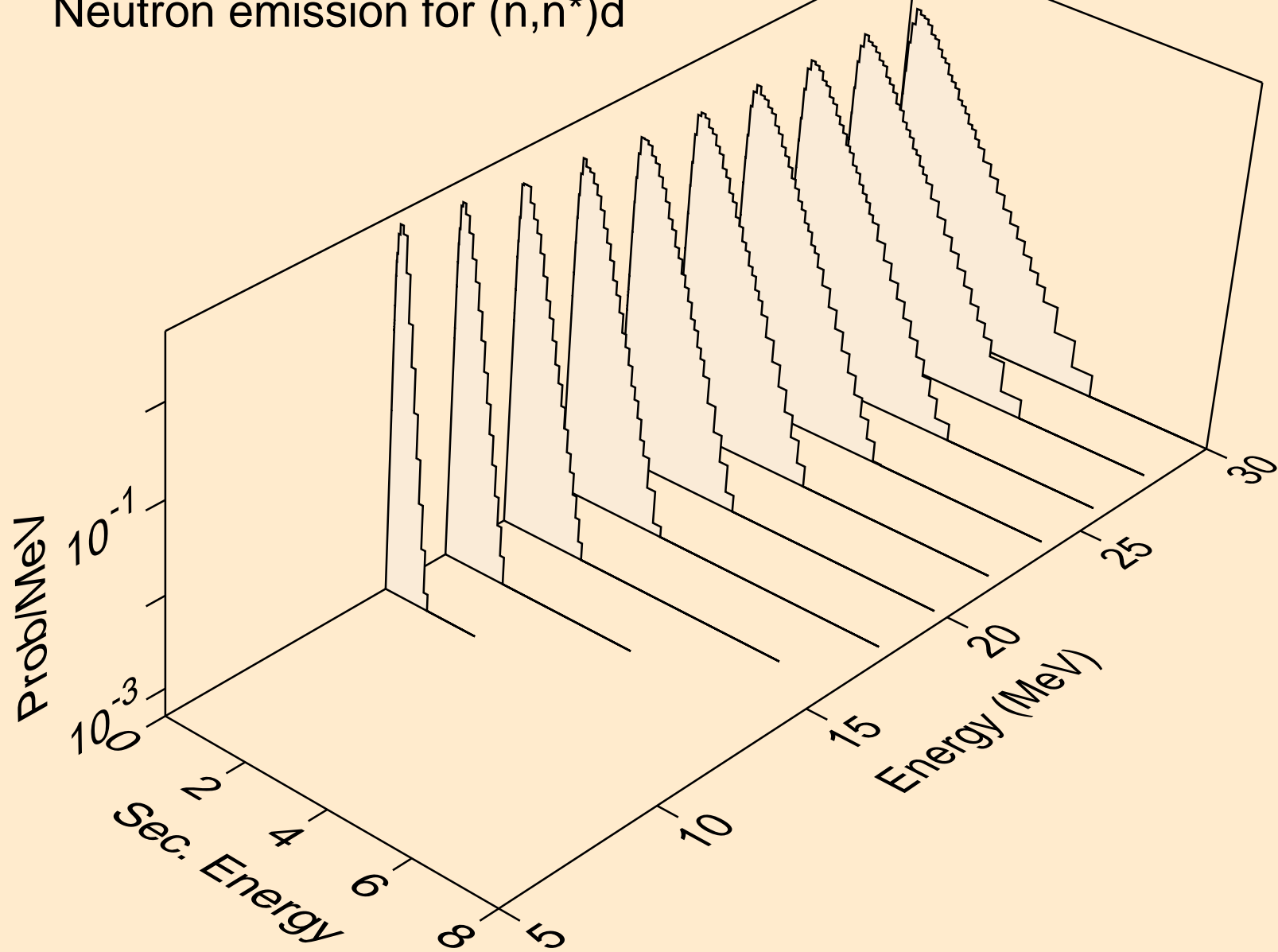

HF177N NEUTRON ACER TENDL-2024 LIBRARY; T=293.6K  
Neutron emission for (n,n\*)t

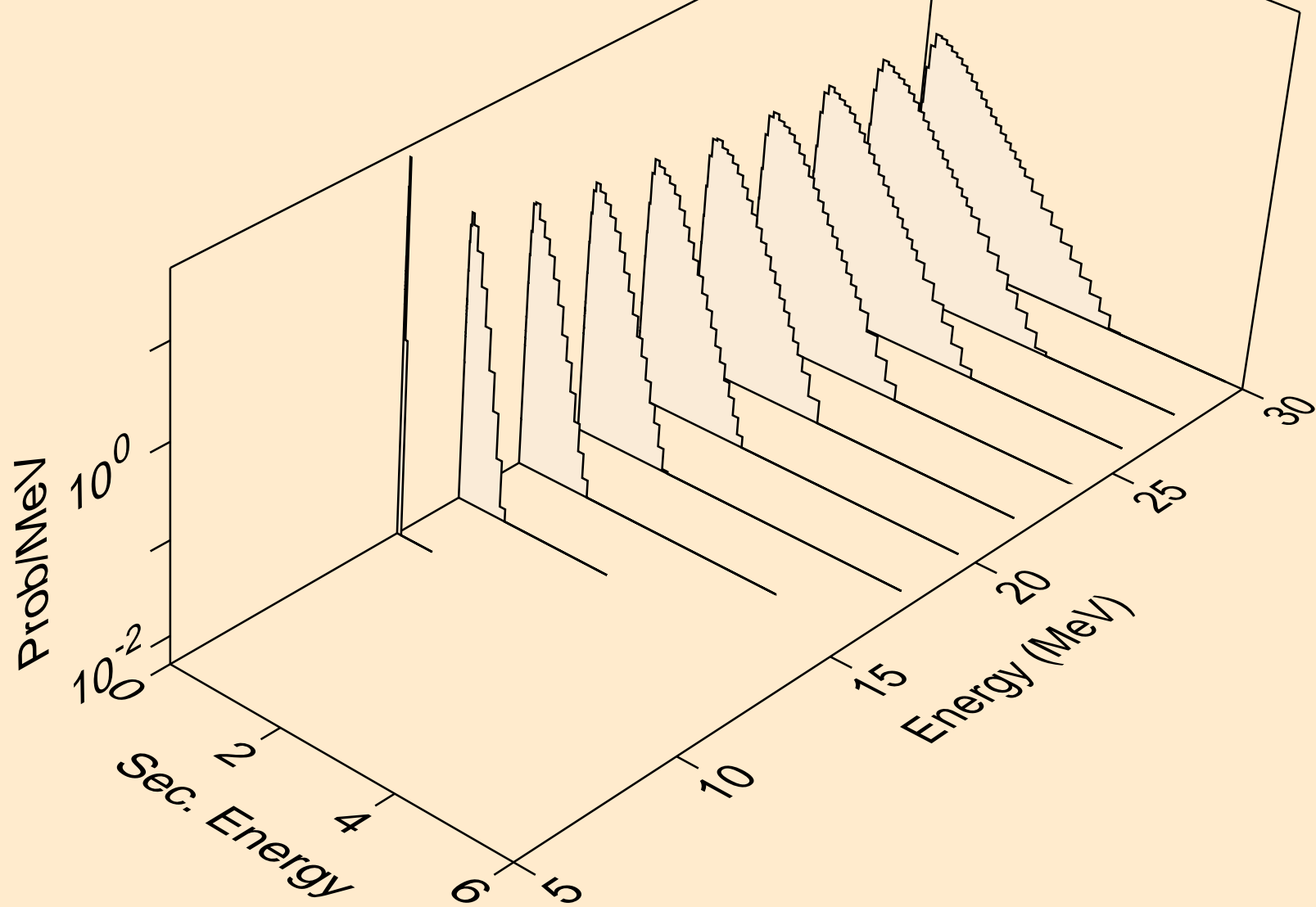

HF177N NEUTRON ACER TENDL-2024 LIBRARY; T=293.6K  
Neutron emission for (n,n\*)he3

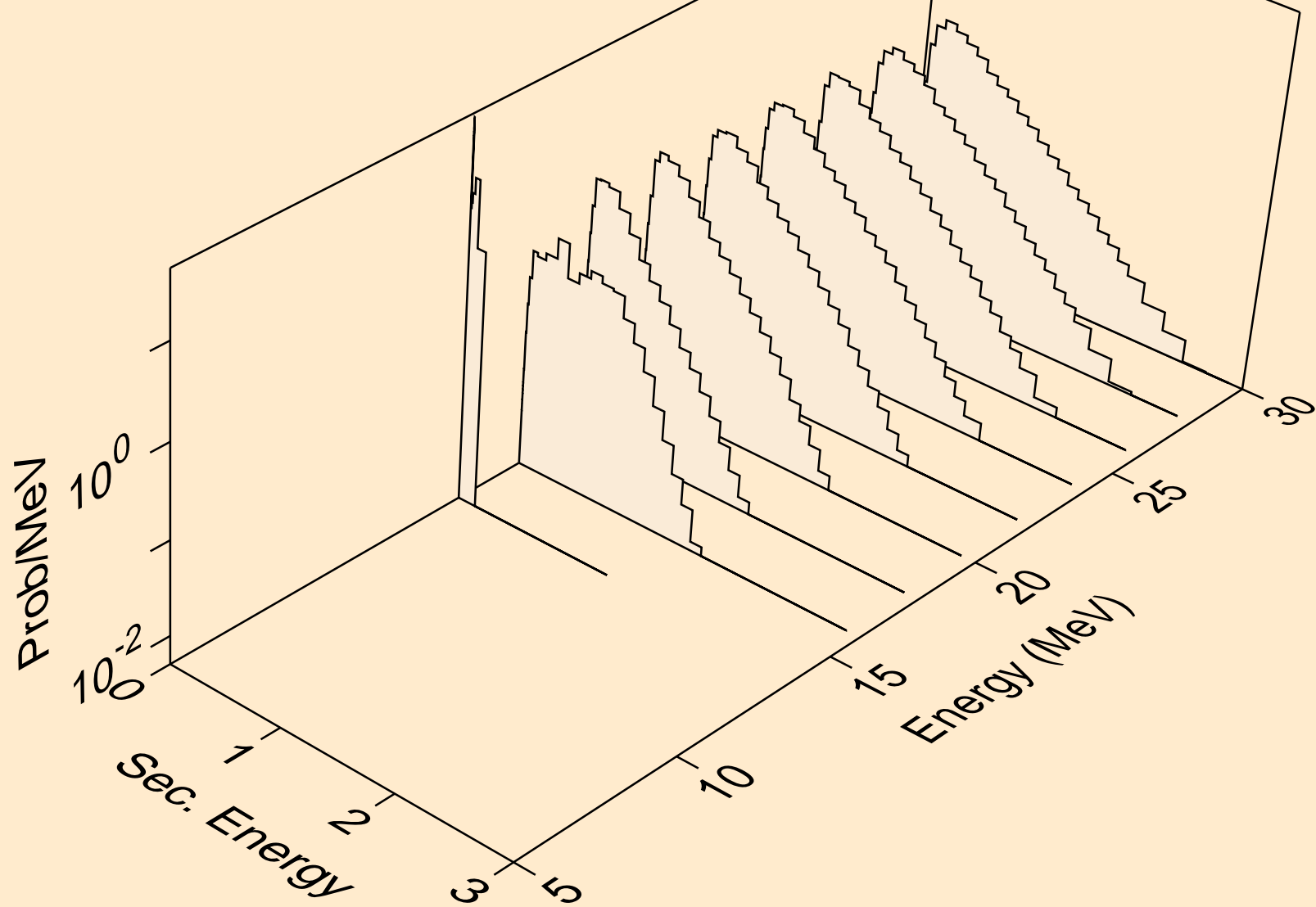

HF177N NEUTRON ACER TENDL-2024 LIBRARY; T=293.6K  
Neutron emission for (n,4n)

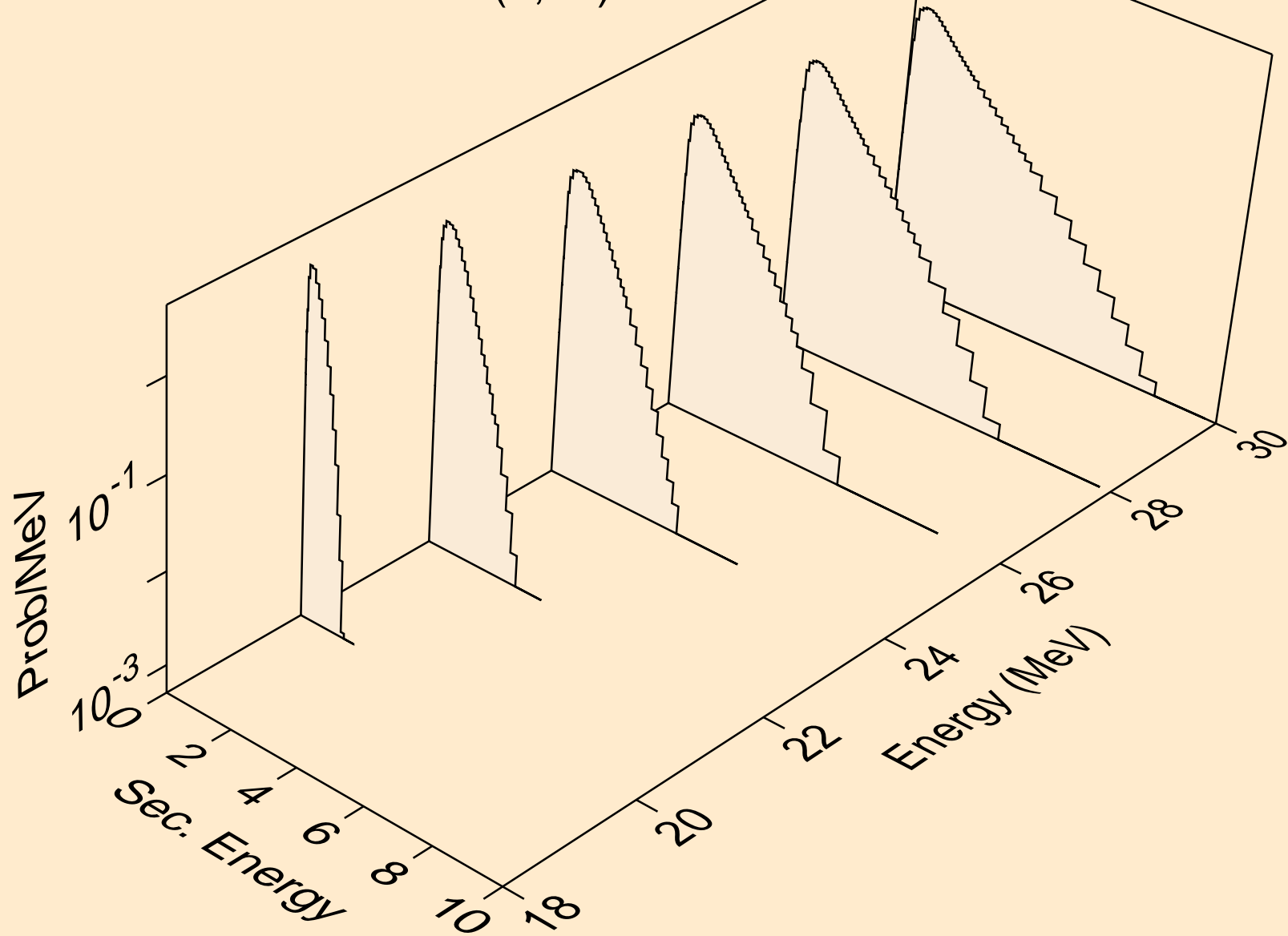

HF177N NEUTRON ACER TENDL-2024 LIBRARY; T=293.6K  
Neutron emission for (n,2np)

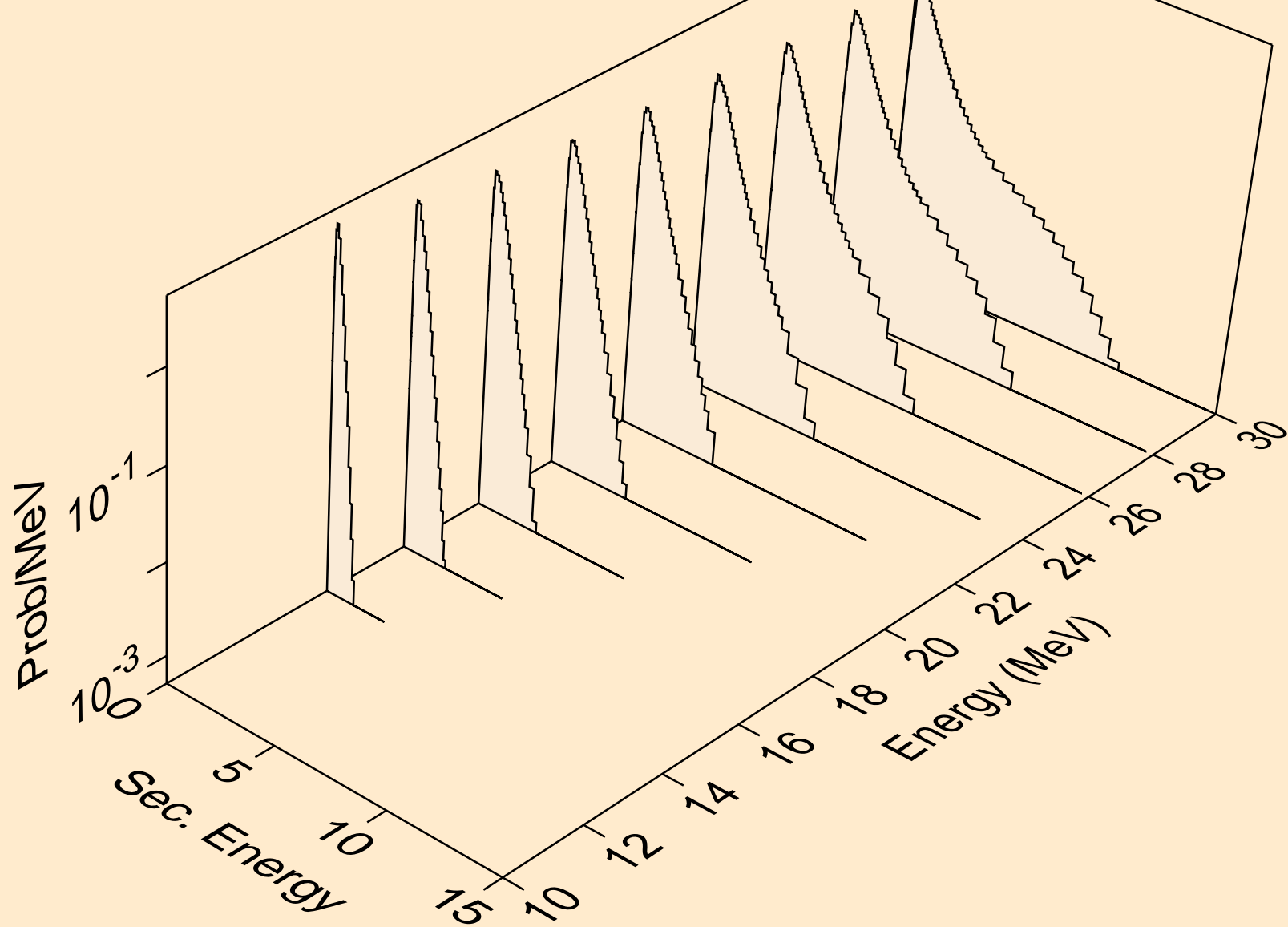

HF177N NEUTRON ACER TENDL-2024 LIBRARY; T=293.6K  
Neutron emission for (n,3np)

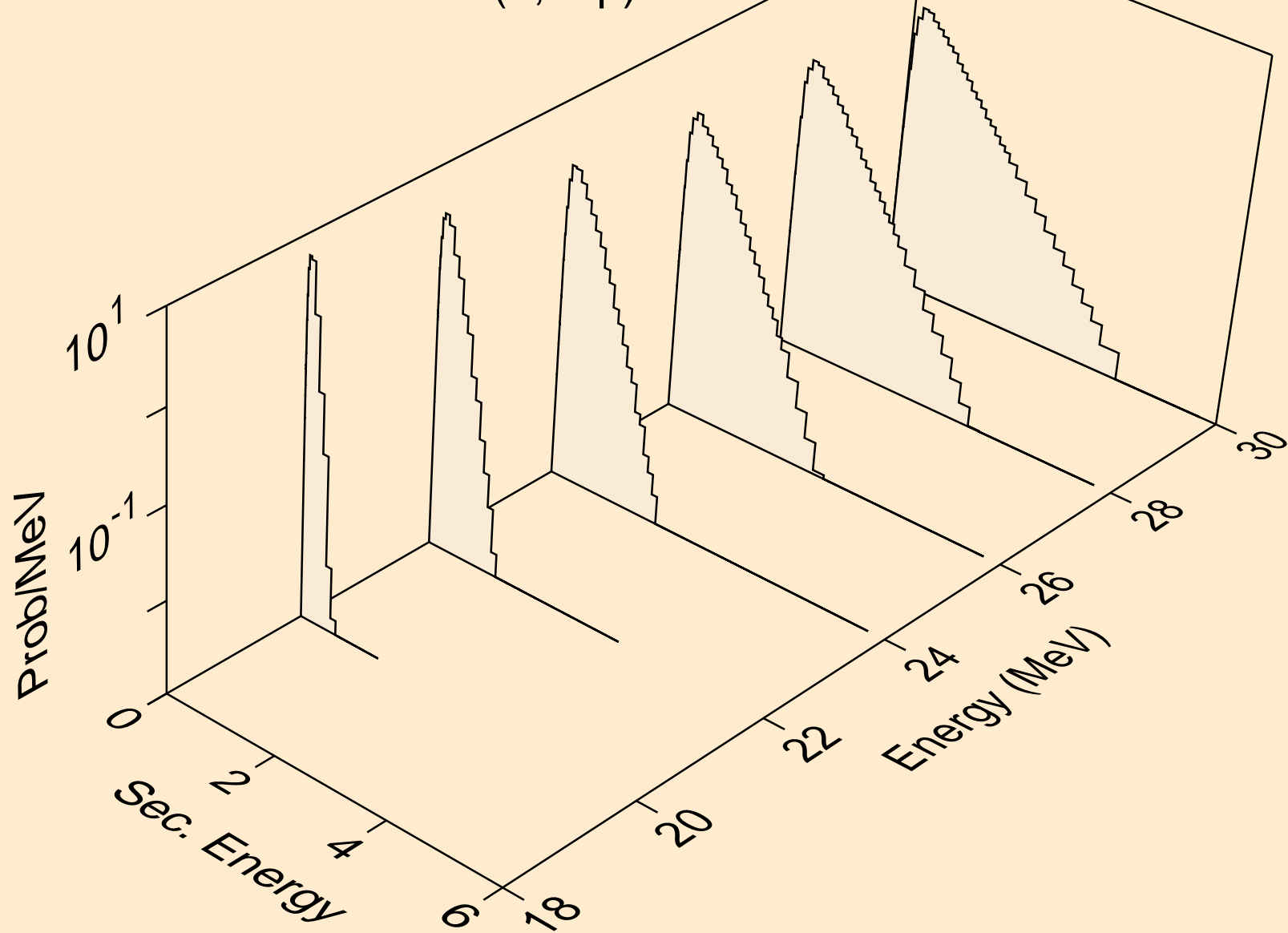

HF177N NEUTRON ACER TENDL-2024 LIBRARY; T=293.6K  
Neutron emission for (n,n2p)

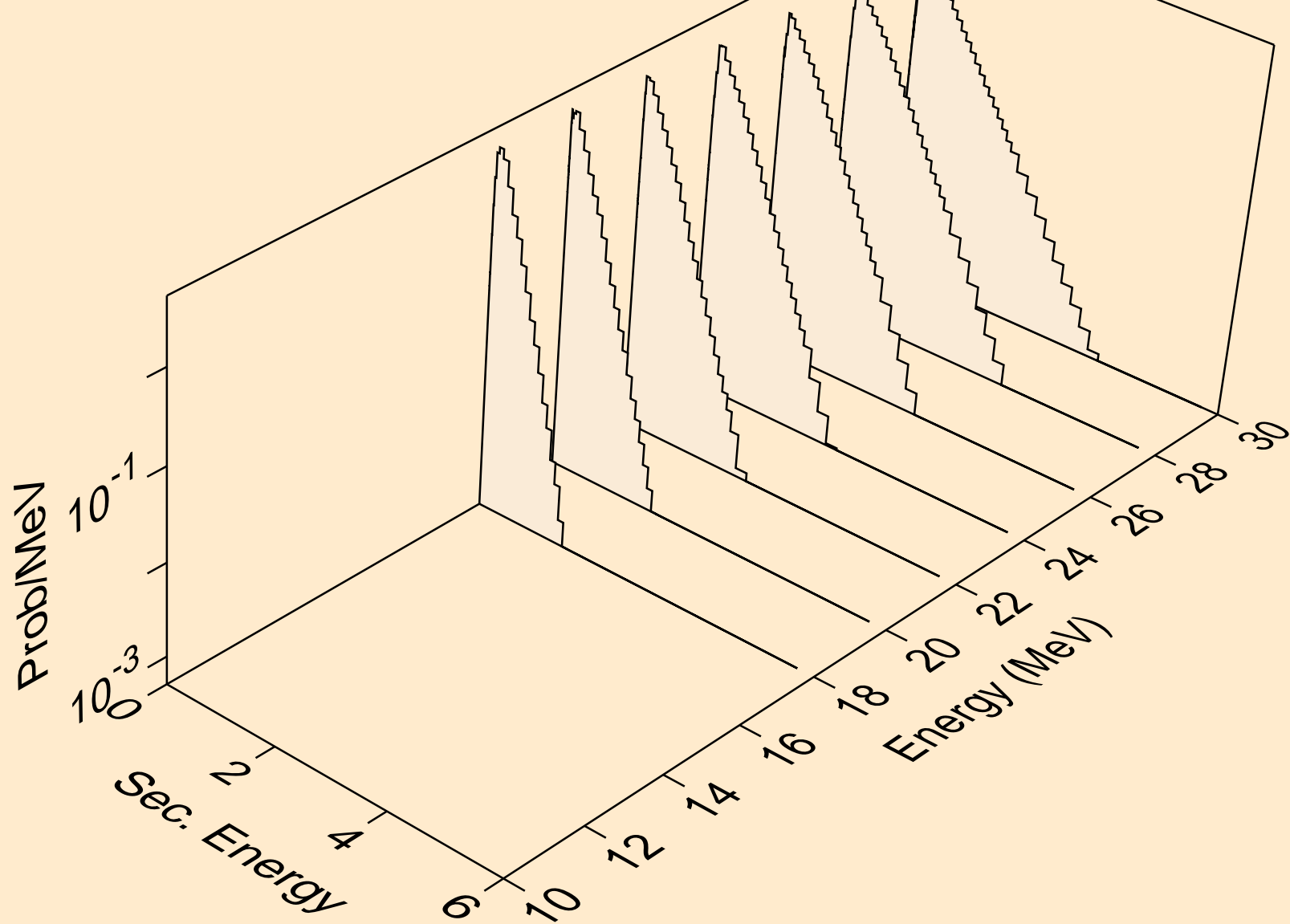

HF177N NEUTRON ACER TENDL-2024 LIBRARY; T=293.6K  
Neutron emission for (n,npa)

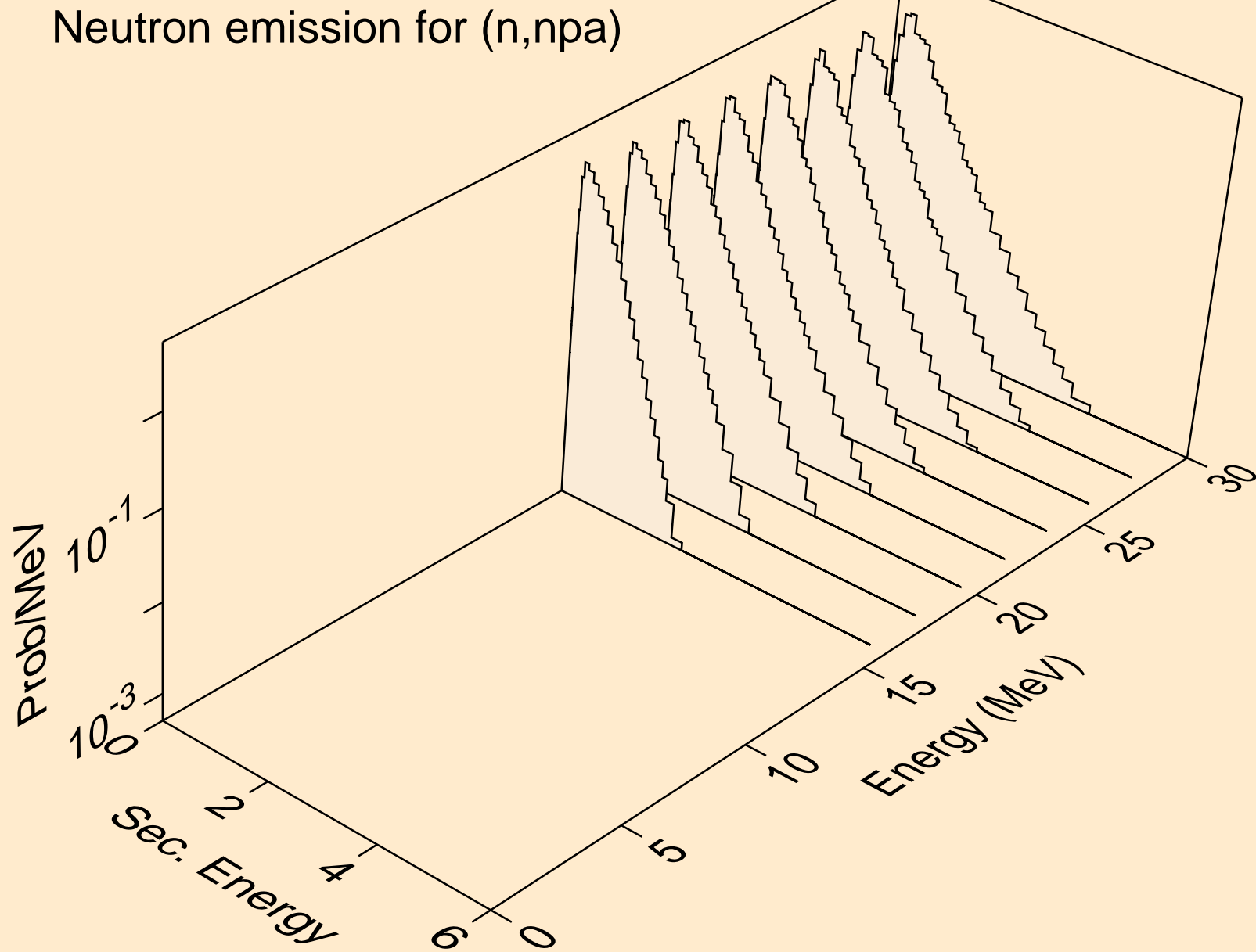

HF177N NEUTRON ACER TENDL-2024 LIBRARY; T=293.6K  
Neutron emission for (n,n\*c)

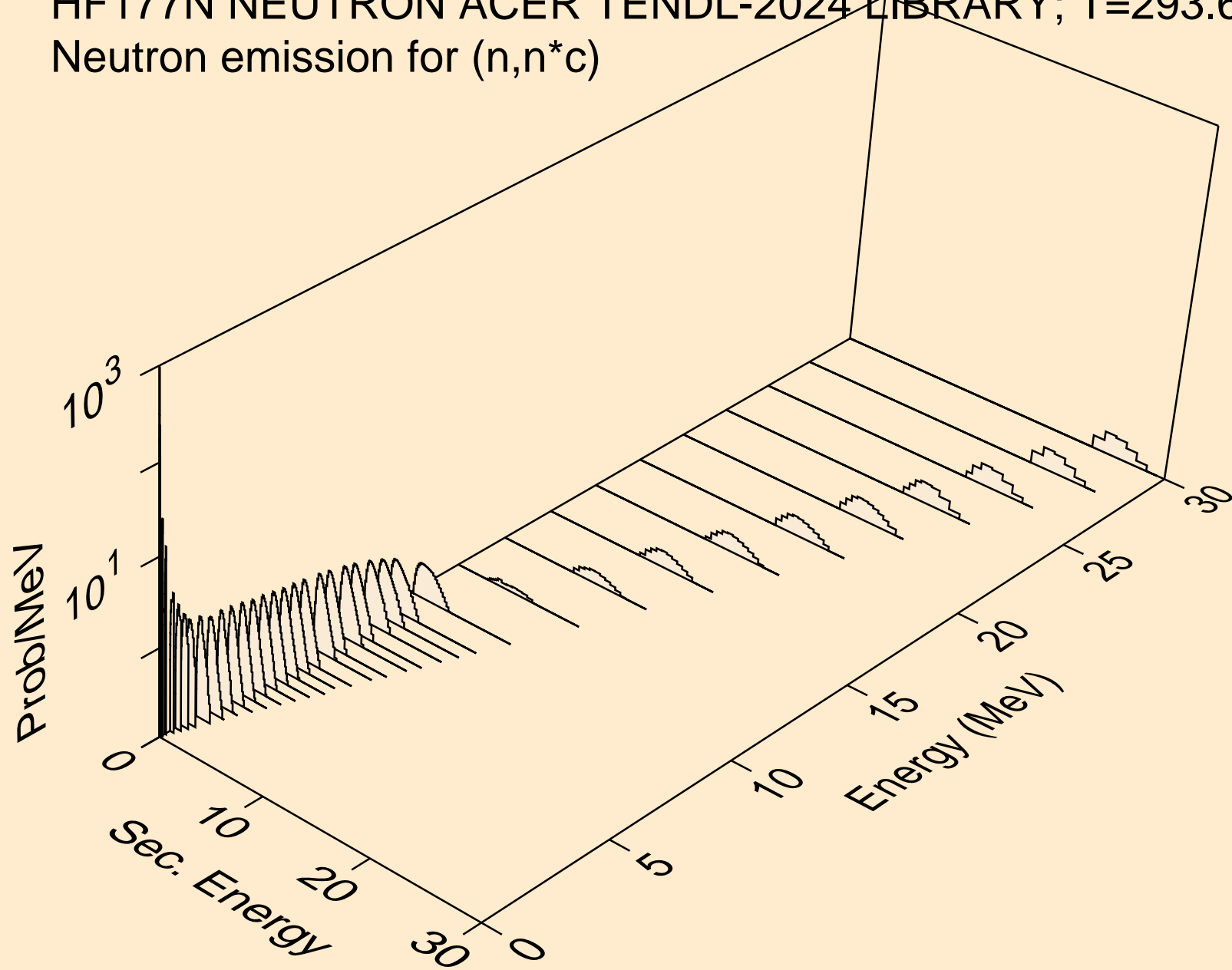

HF177N NEUTRON ACER TENDL-2024 LIBRARY; T=293.6K  
Photon emission for (n,x)

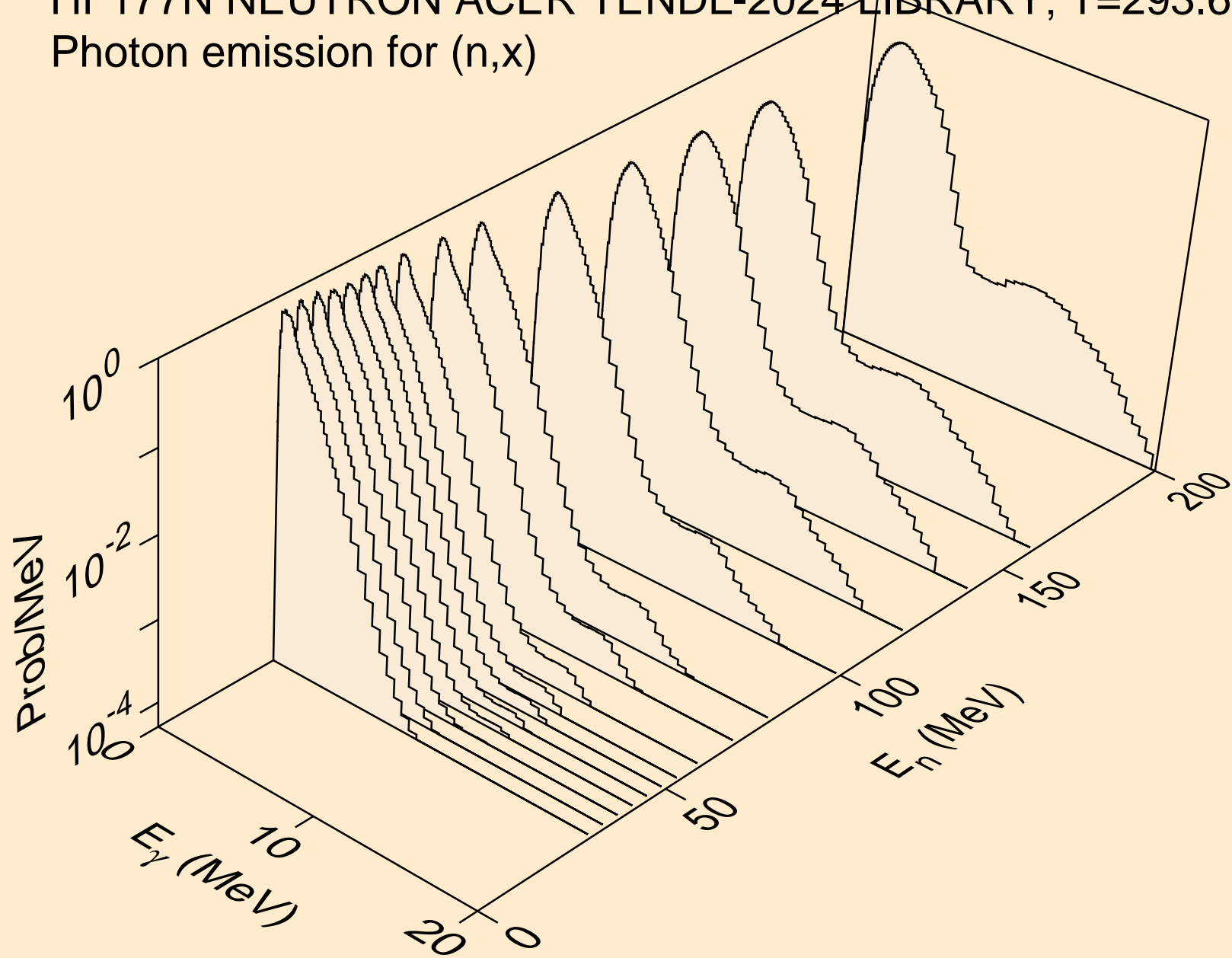

HF177N NEUTRON ACER TENDL-2024 LIBRARY; T=293.6K  
Photon emission for (n,2nd)

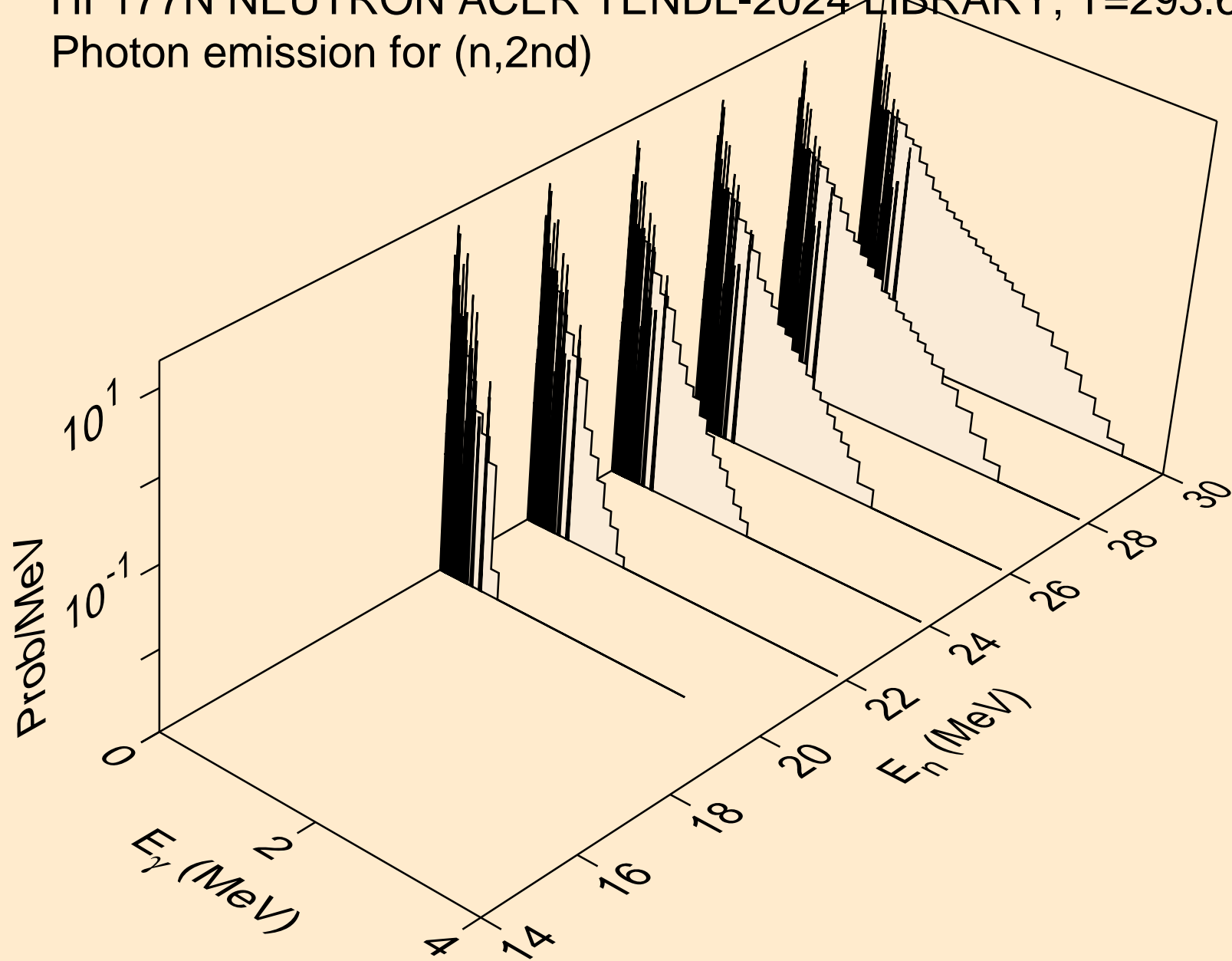

HF177N NEUTRON ACER TENDL-2024 LIBRARY; T=293.6K  
Photon emission for (n,2n)

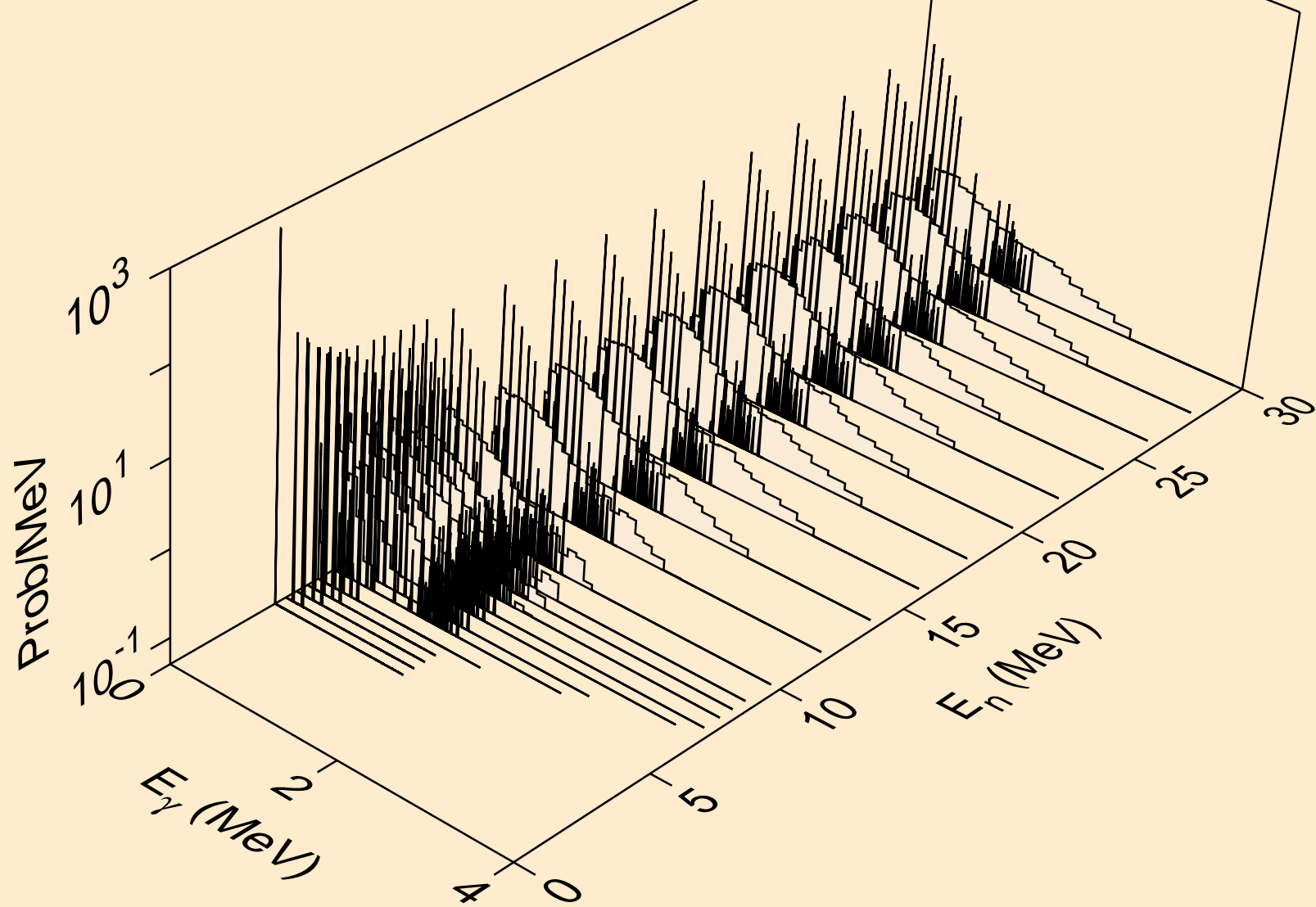

HF177N NEUTRON ACER TENDL-2024 LIBRARY; T=293.6K  
Photon emission for (n,3n)

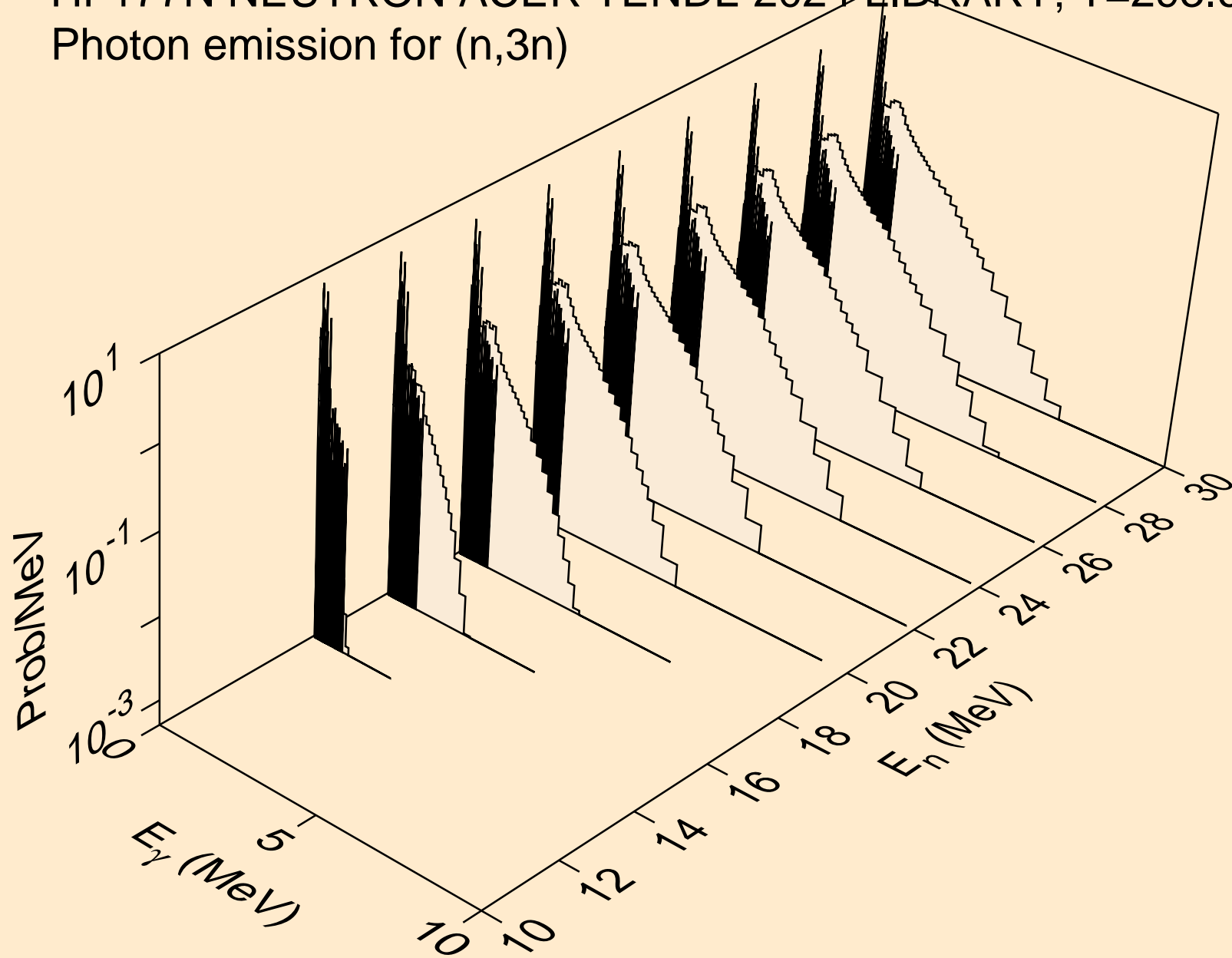

HF177N NEUTRON ACER TENDL-2024 LIBRARY; T=293.6K  
Photon emission for (n,n\*)a

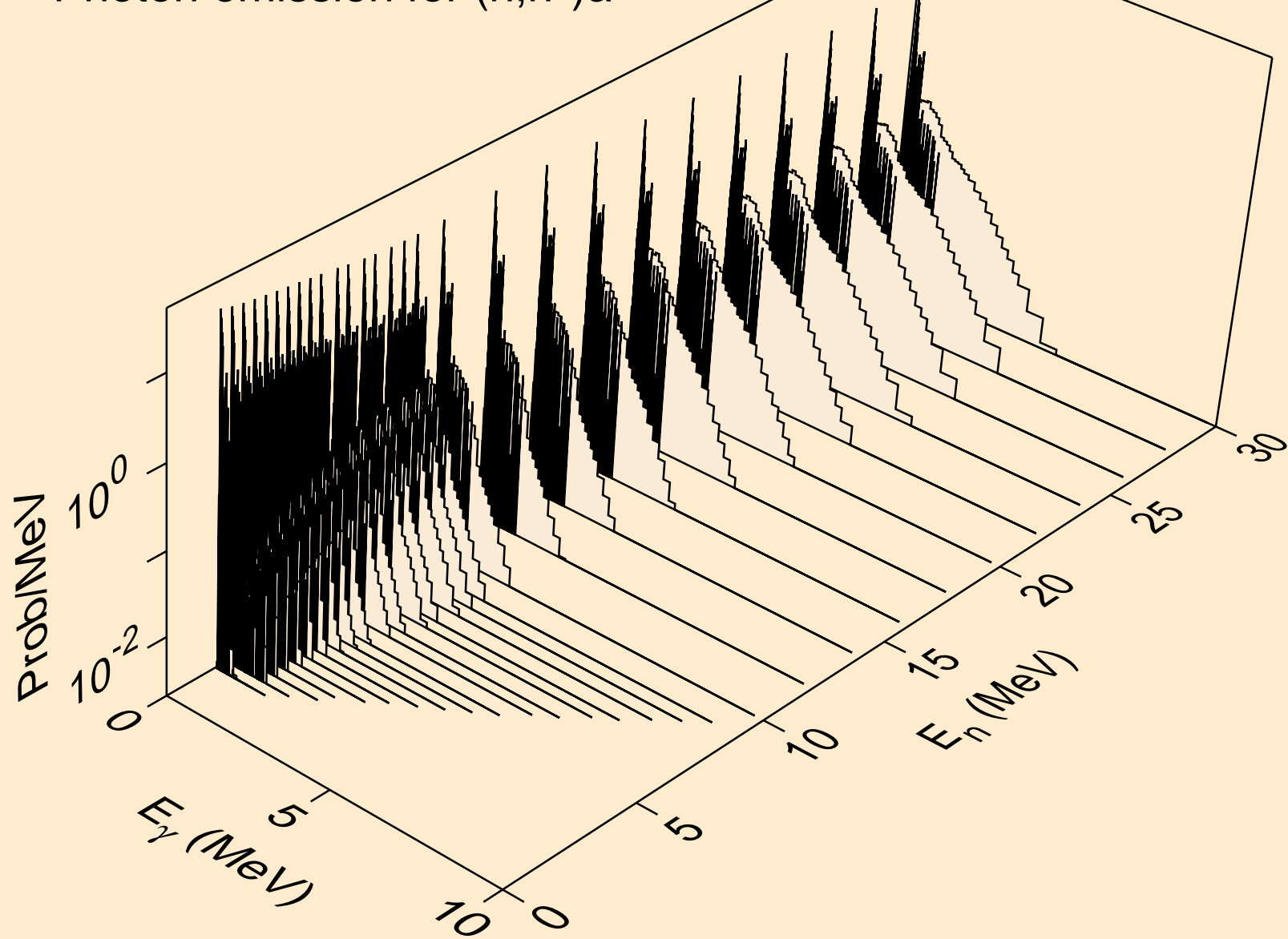

HF177N NEUTRON ACER TENDL-2024 LIBRARY; T=293.6K  
Photon emission for (n,2n)a

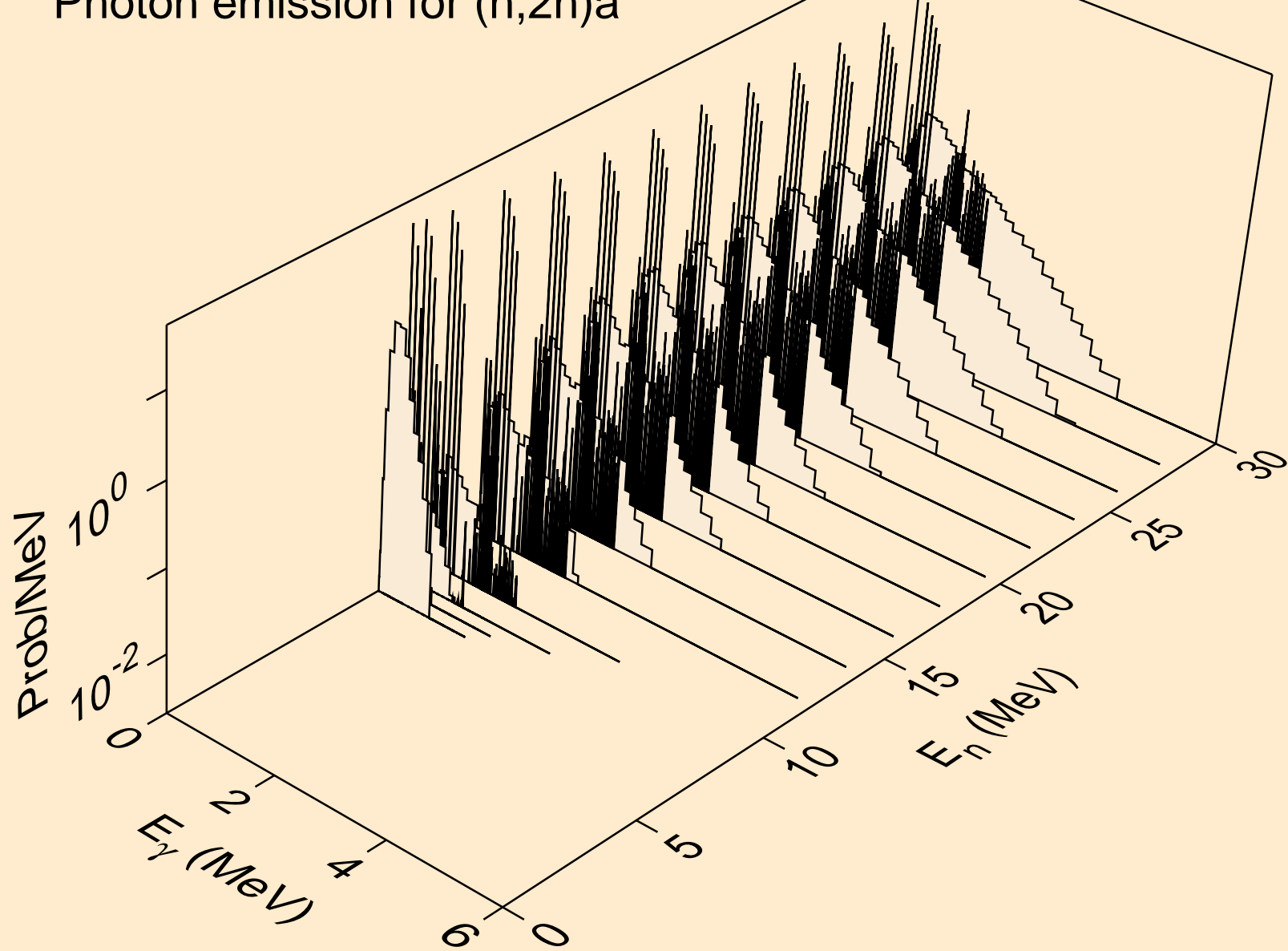

HF177N NEUTRON ACER TENDL-2024 LIBRARY; T=293.6K  
Photon emission for (n,3n)a

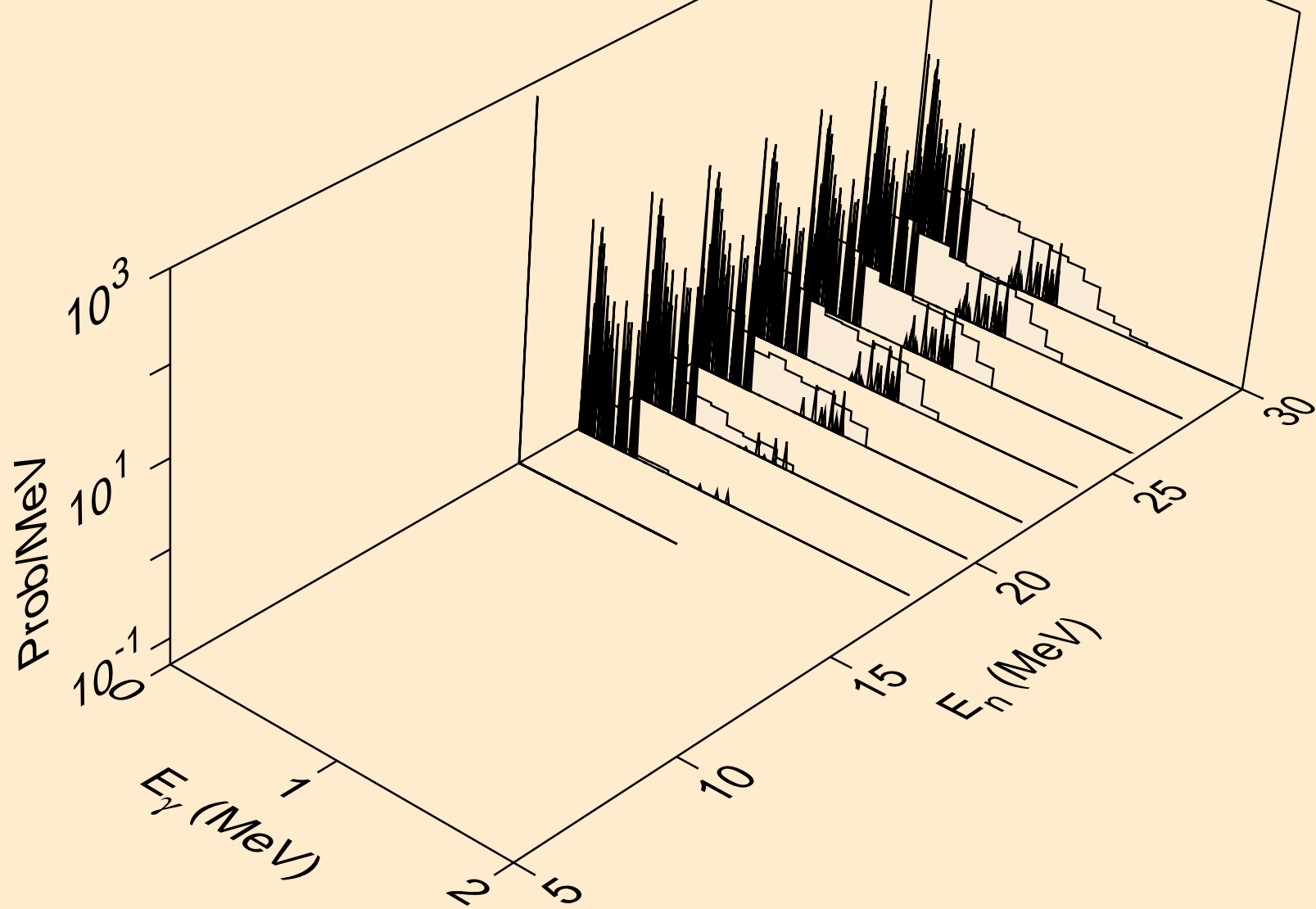

HF177N NEUTRON ACER TENDL-2024 LIBRARY; T=293.6K  
Photon emission for (n,n\*)p

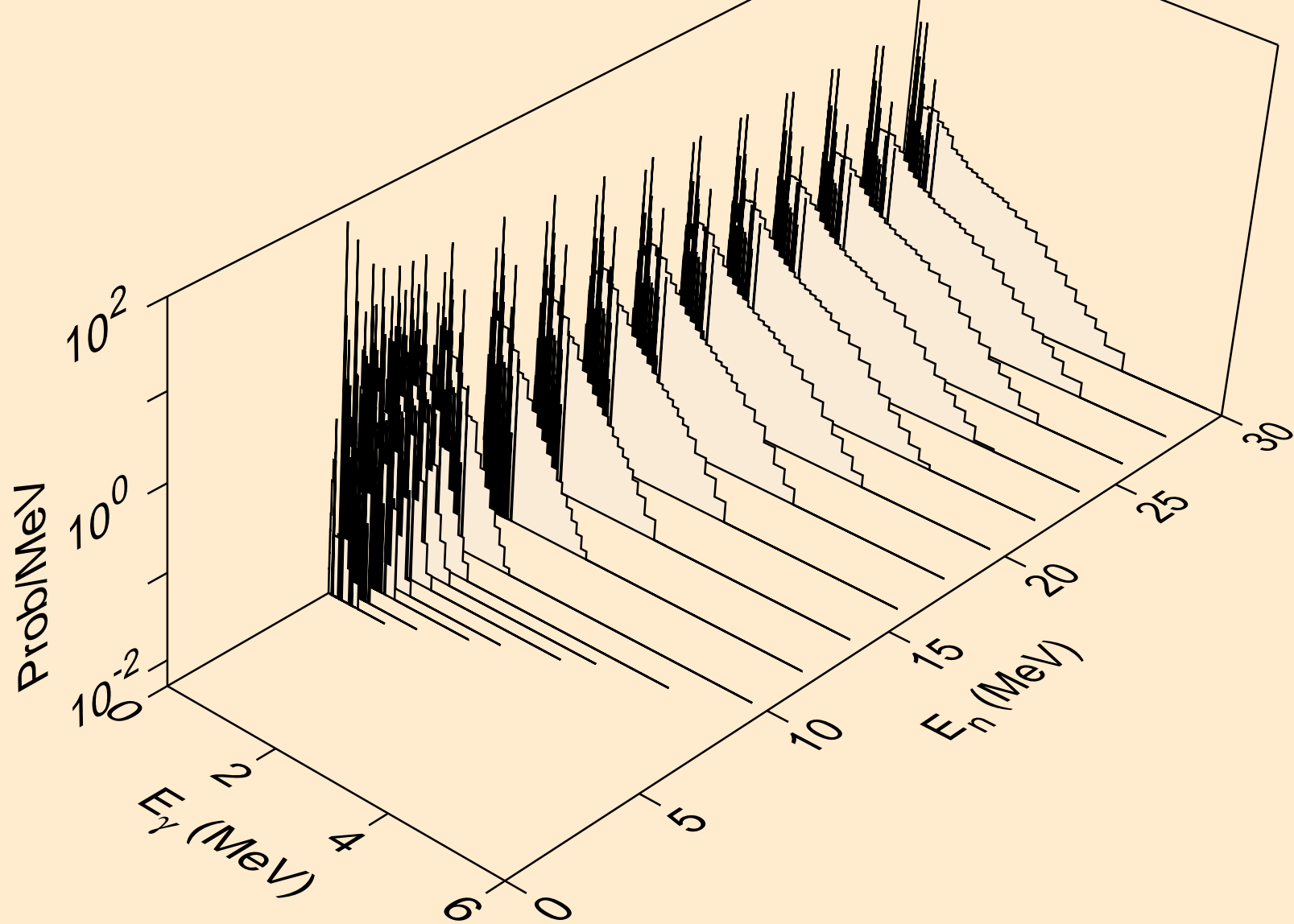

HF177N NEUTRON ACER TENDL-2024 LIBRARY; T=293.6K  
Photon emission for (n,n\*)2a

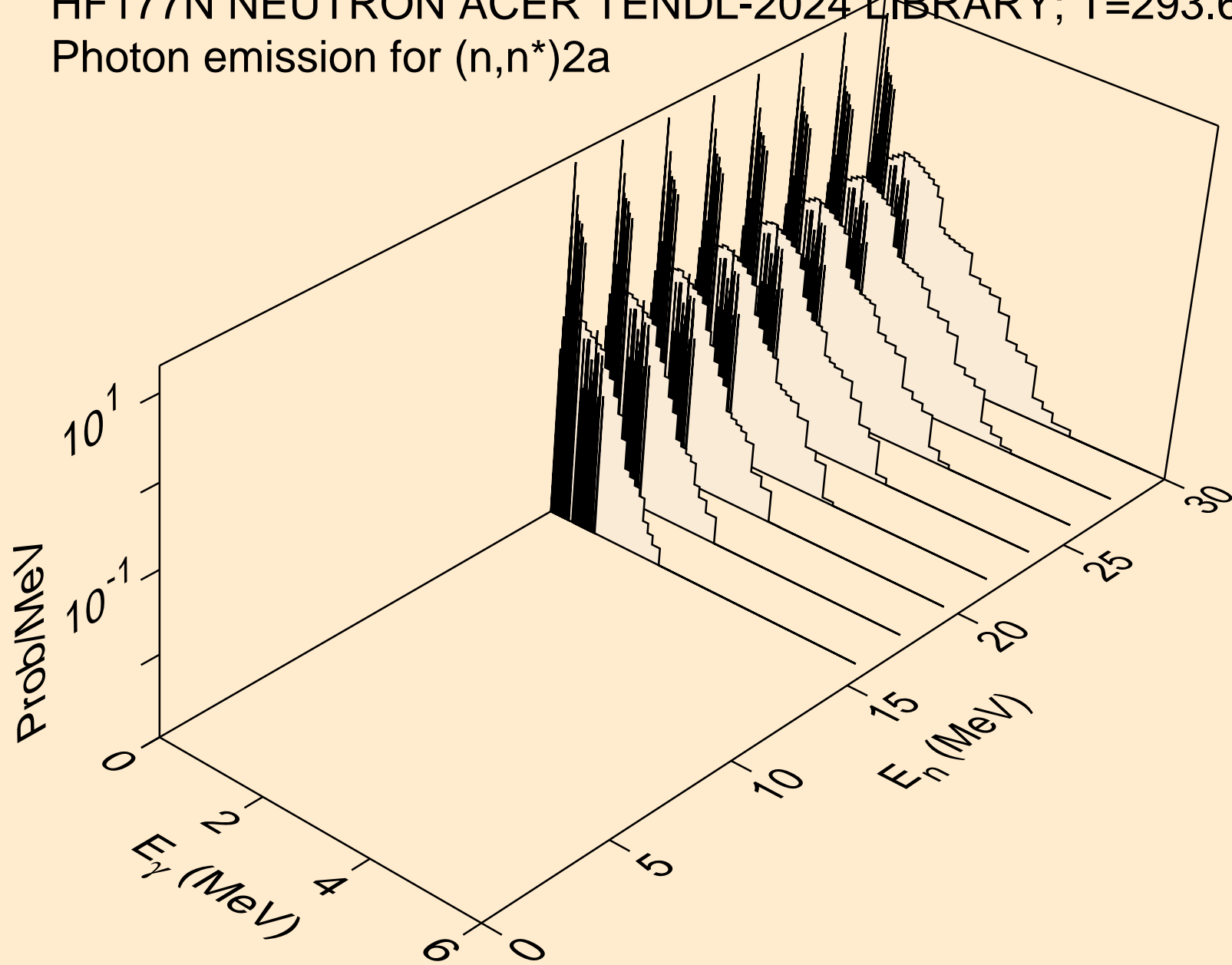

HF177N NEUTRON ACER TENDL-2024 LIBRARY; T=293.6K  
Photon emission for (n,n\*)d

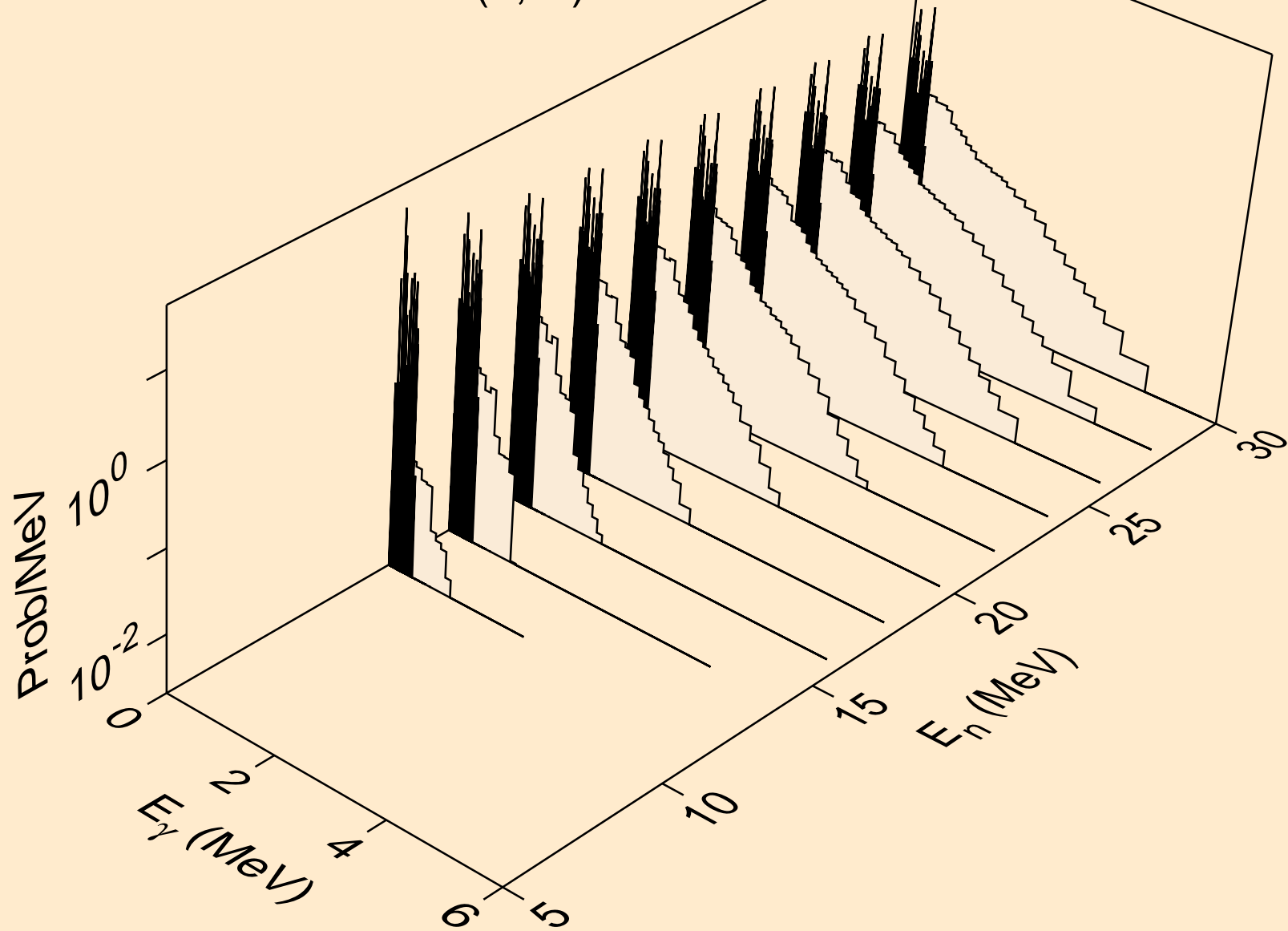

HF177N NEUTRON ACER TENDL-2024 LIBRARY; T=293.6K  
Photon emission for (n,n\*)t

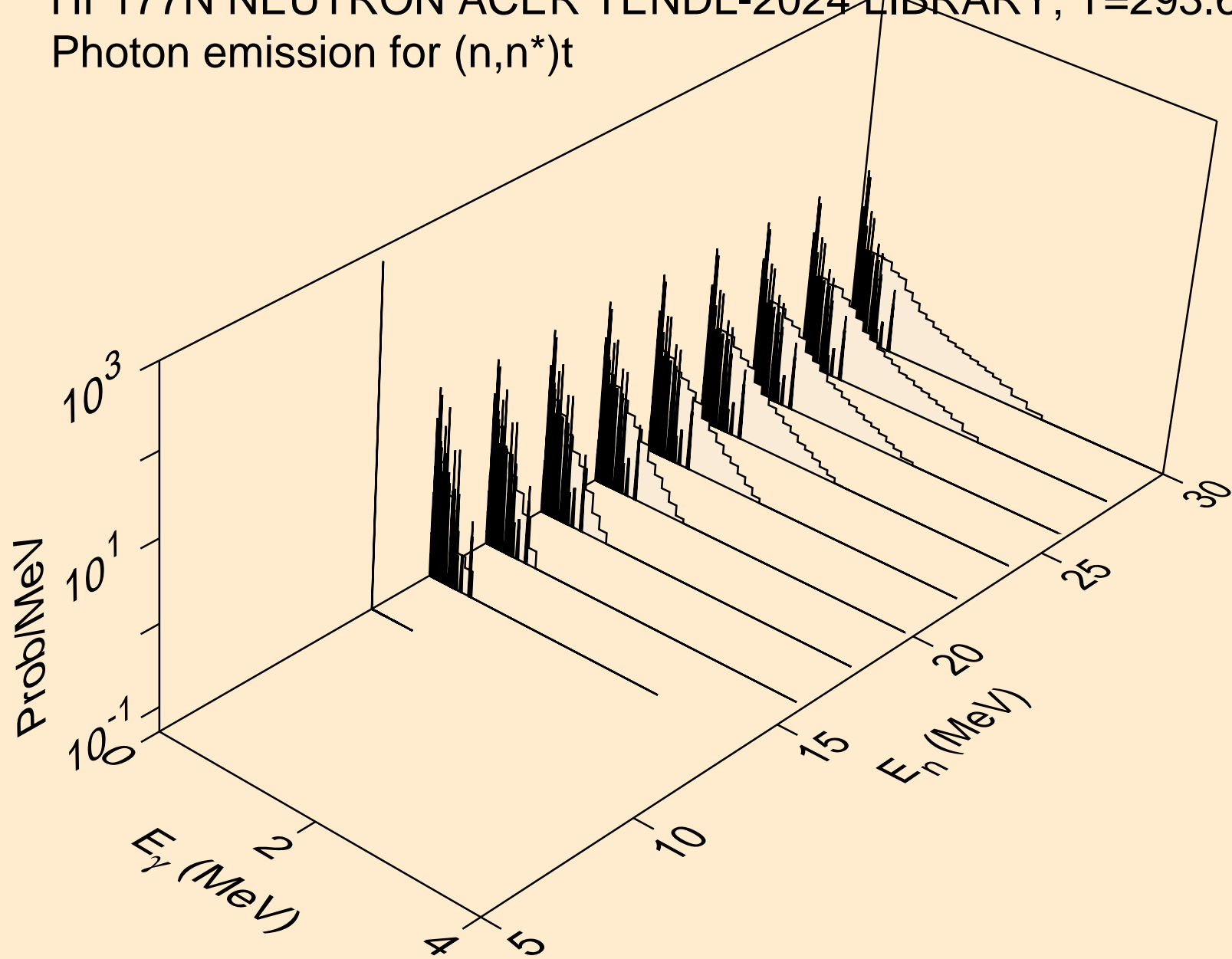

HF177N NEUTRON ACER TENDL-2024 LIBRARY; T=293.6K  
Photon emission for (n,n\*)he3

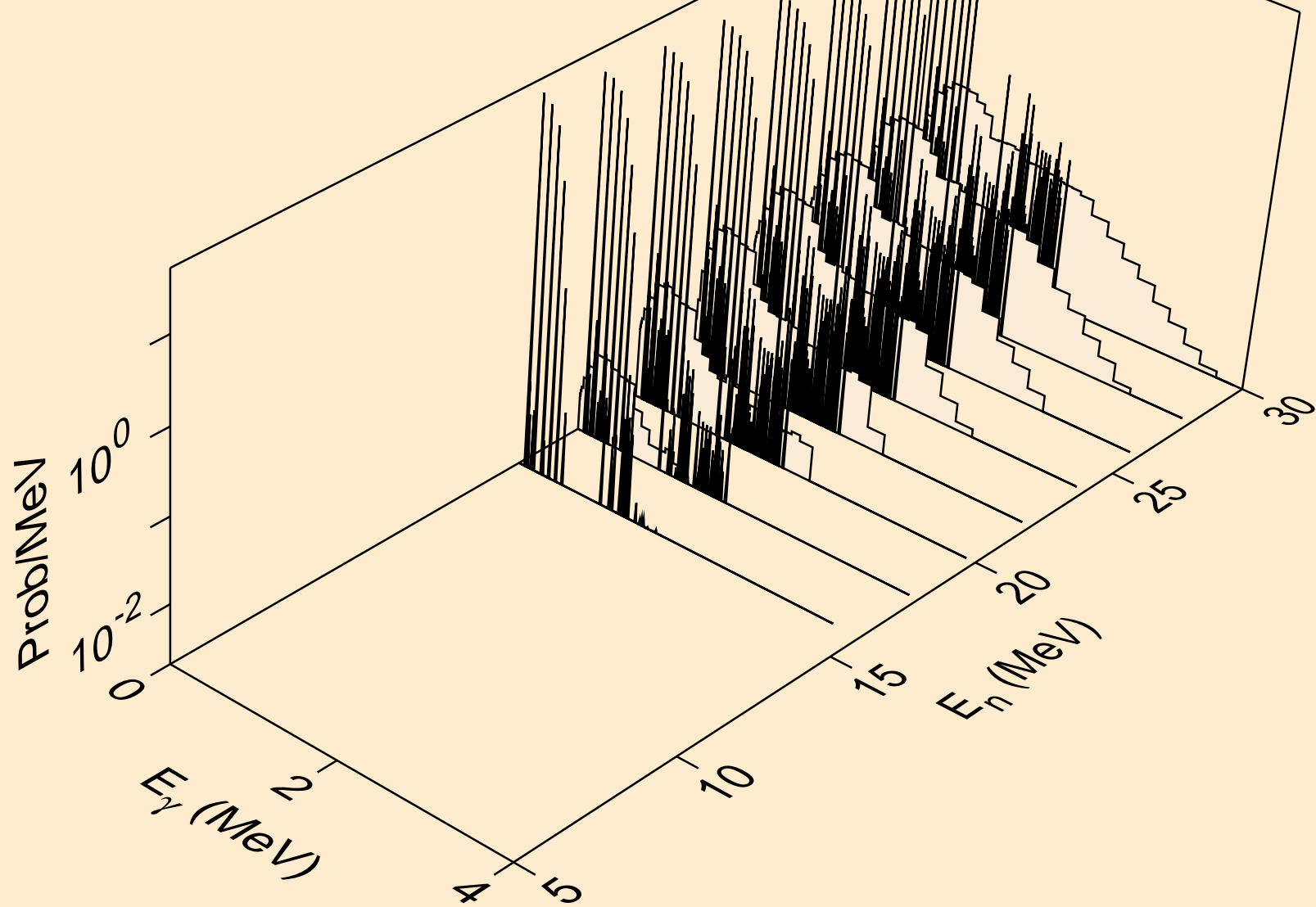

HF177N NEUTRON ACER TENDL-2024 LIBRARY; T=293.6K  
Photon emission for (n,4n)

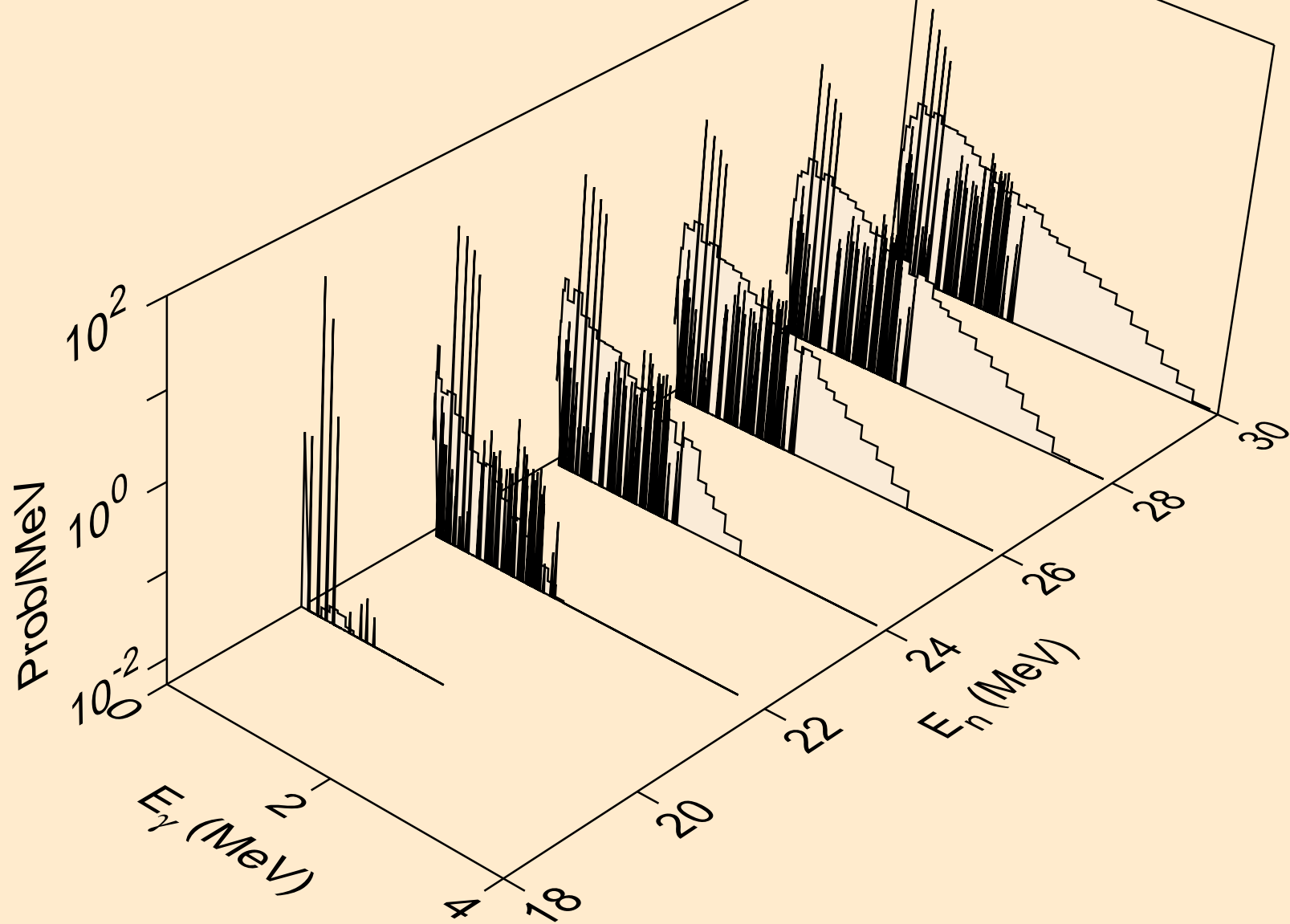

HF177N NEUTRON ACER TENDL-2024 LIBRARY; T=293.6K  
Photon emission for (n,2np)

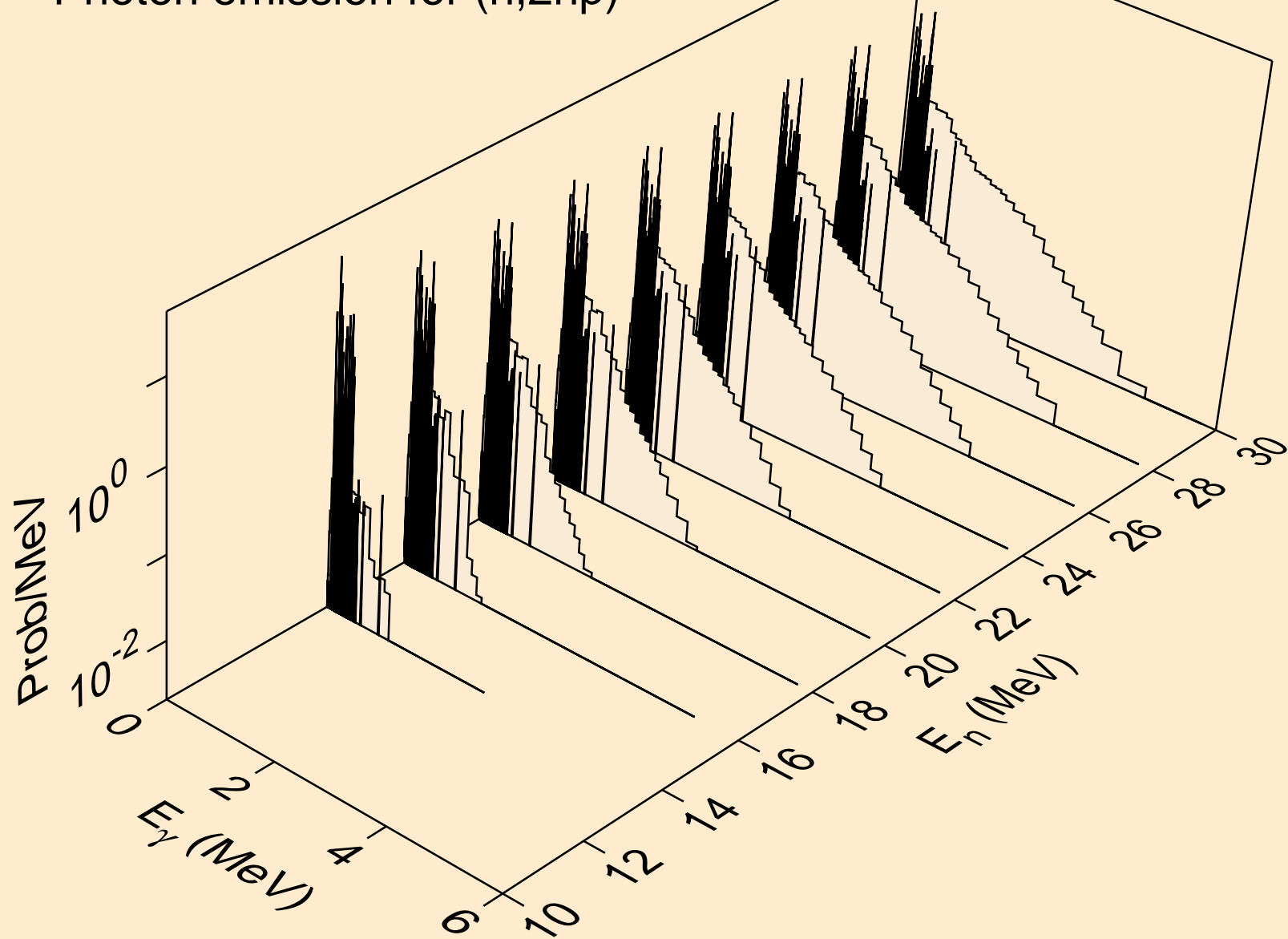

HF177N NEUTRON ACER TENDL-2024 LIBRARY; T=293.6K  
Photon emission for (n,3np)

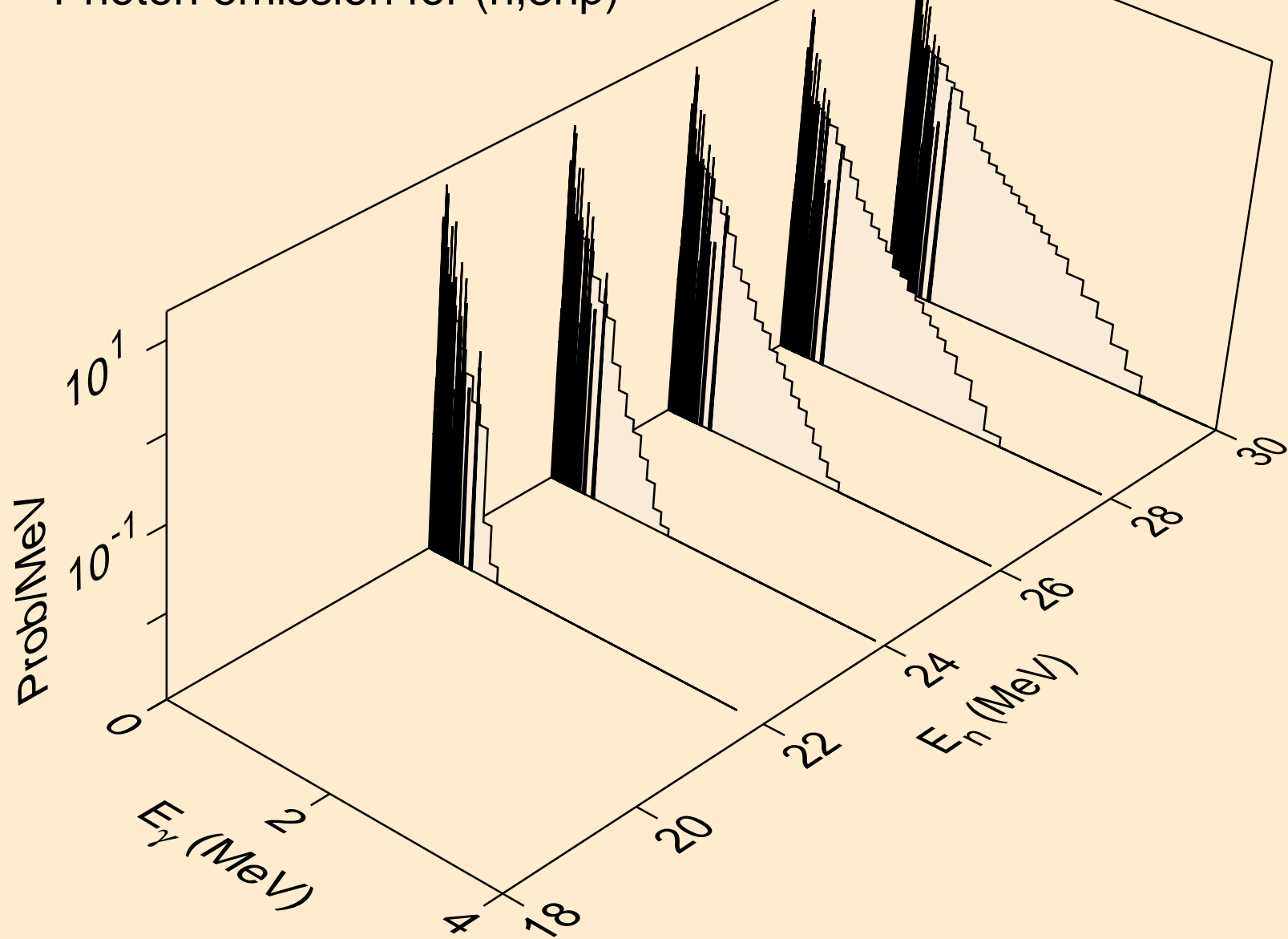

HF177N NEUTRON ACER TENDL-2024 LIBRARY; T=293.6K  
Photon emission for (n,n2p)

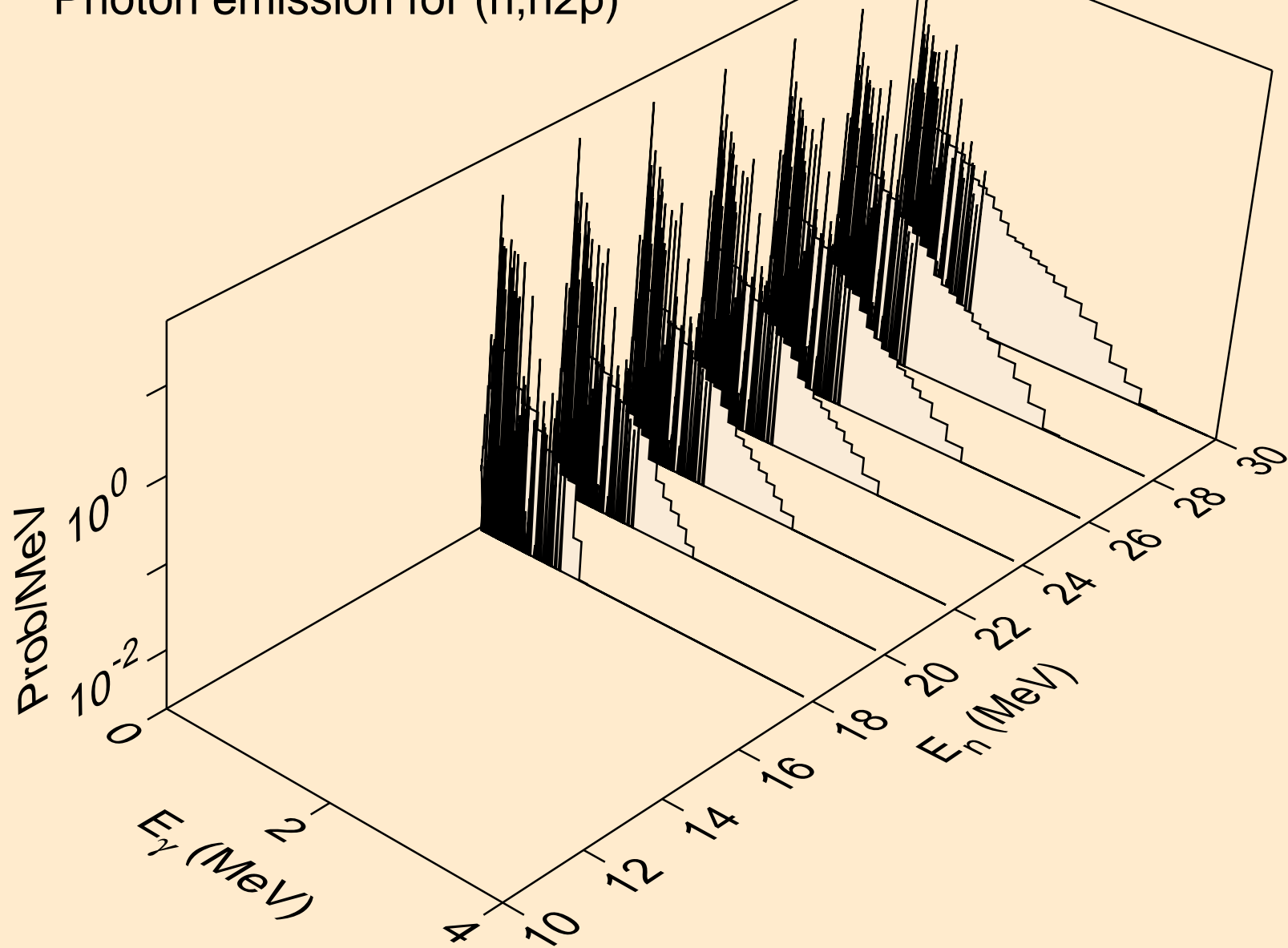

HF177N NEUTRON ACER TENDL-2024 LIBRARY; T=293.6K  
Photon emission for (n,npa)

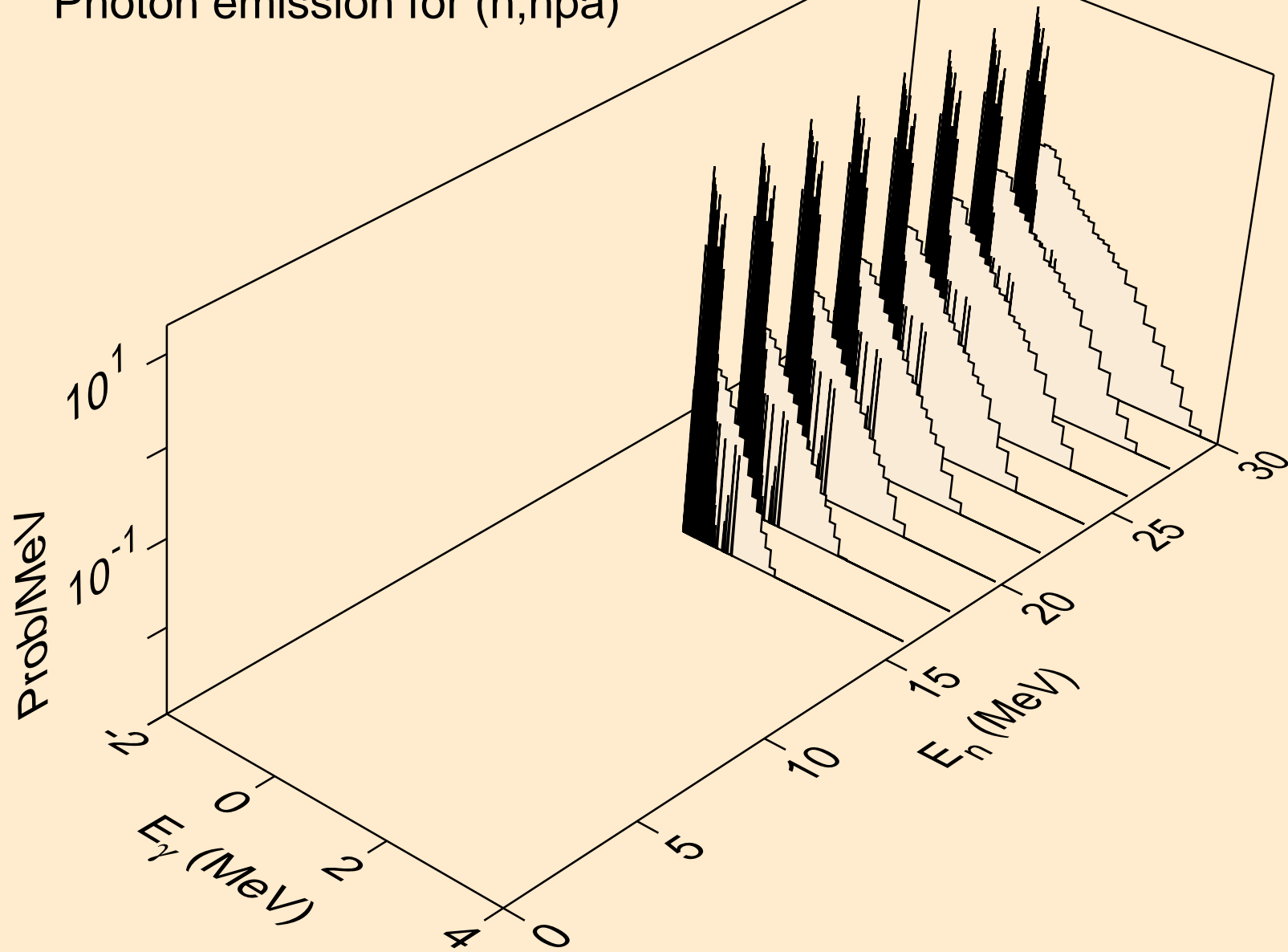

HF177N NEUTRON ACER TENDL-2024 LIBRARY; T=293.6K  
Photon emission for (n,n\*1)

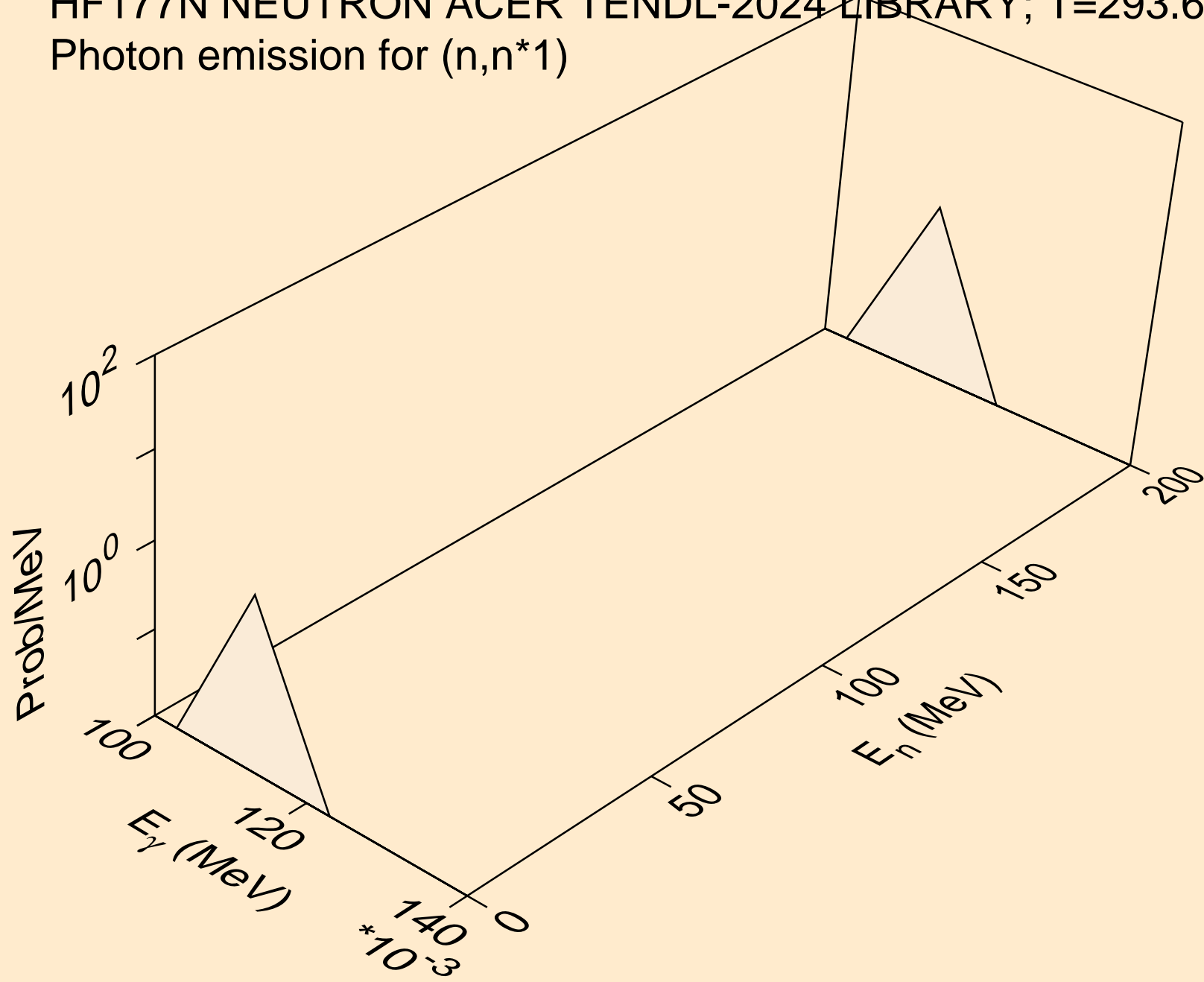

HF177N NEUTRON ACER TENDL-2024 LIBRARY; T=293.6K  
Photon emission for (n,n\*2)

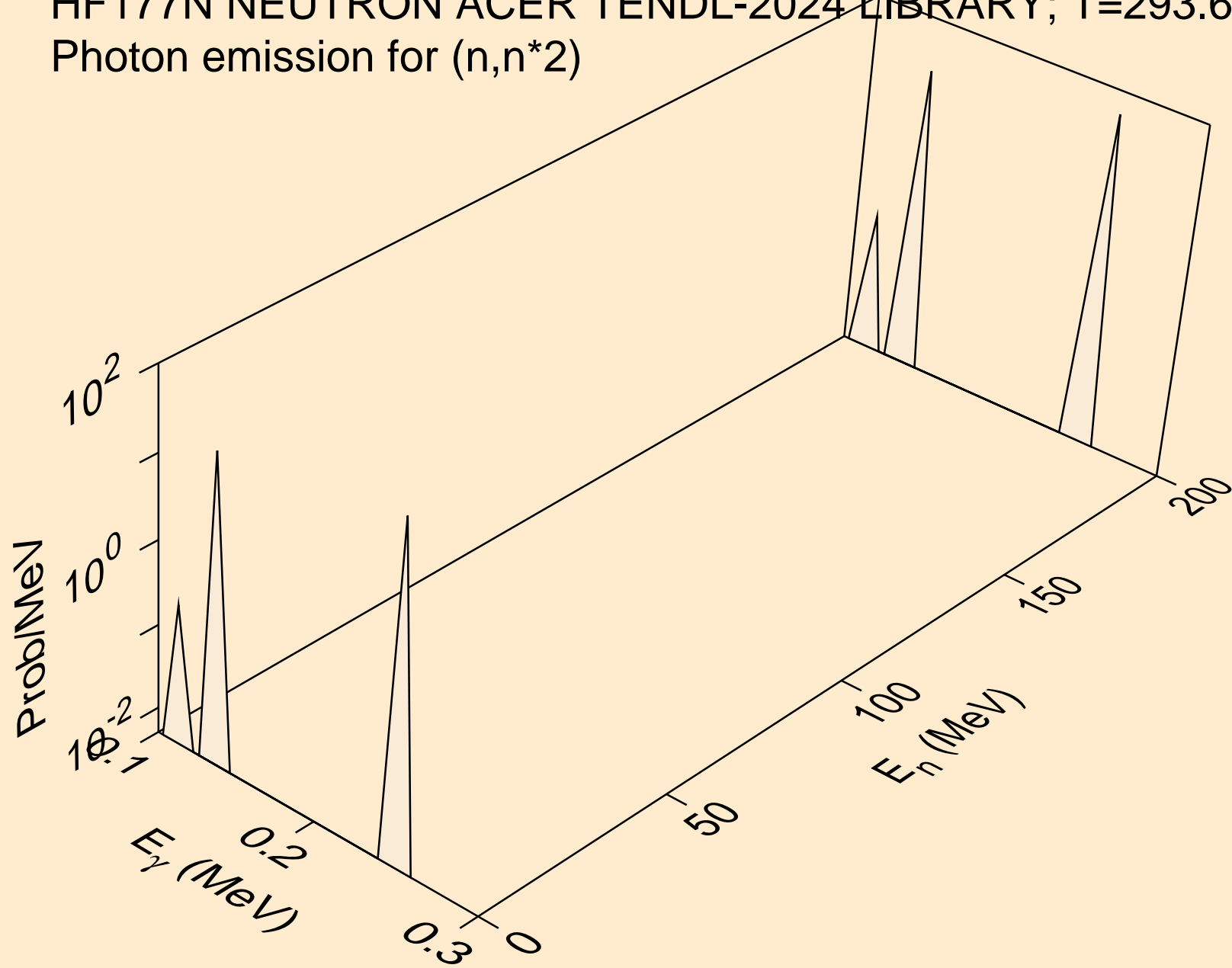

HF177N NEUTRON ACER TENDL-2024 LIBRARY; T=293.6K  
Photon emission for (n,n\*3)

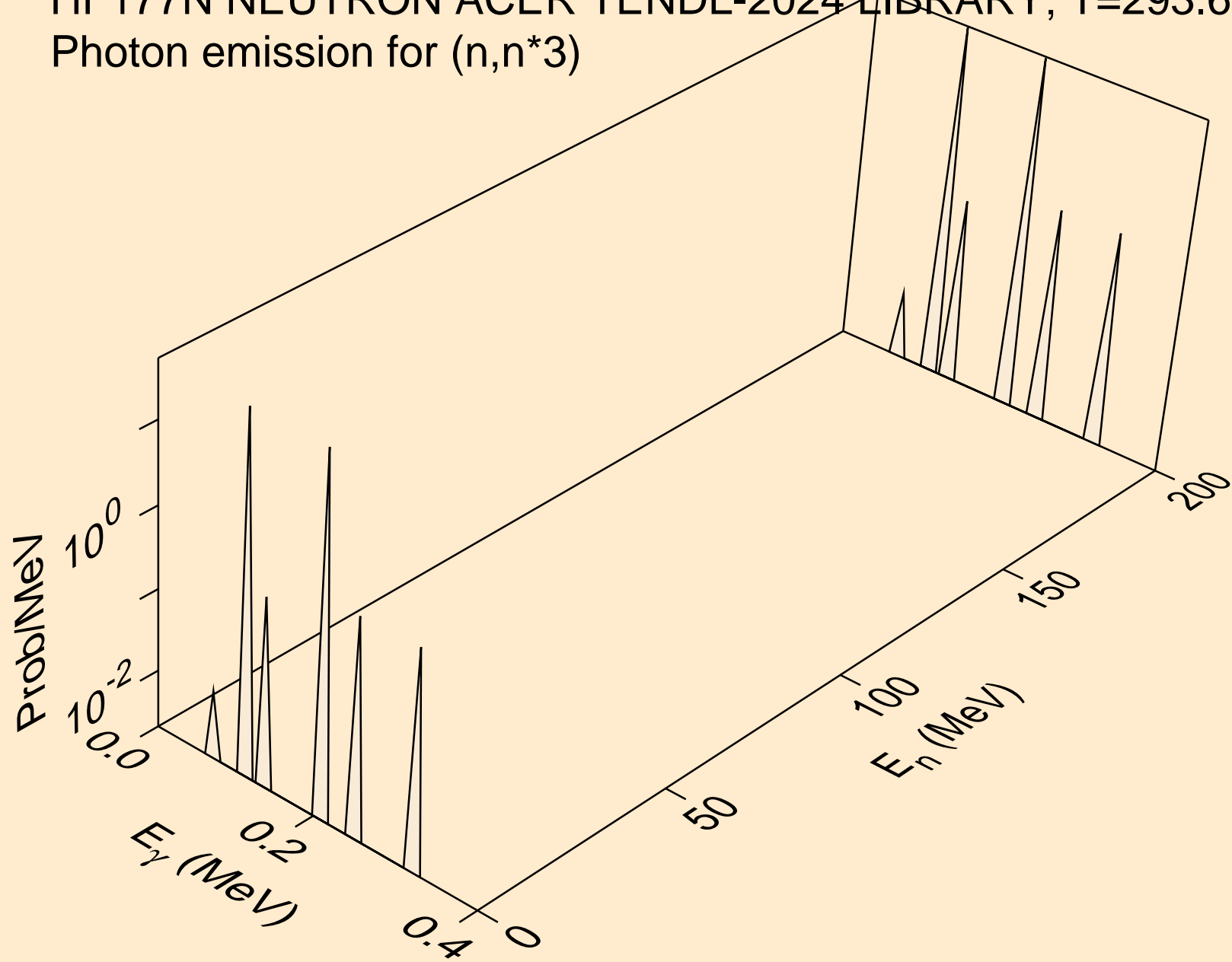

HF177N NEUTRON ACER TENDL-2024 LIBRARY; T=293.6K  
Photon emission for (n,n\*4)

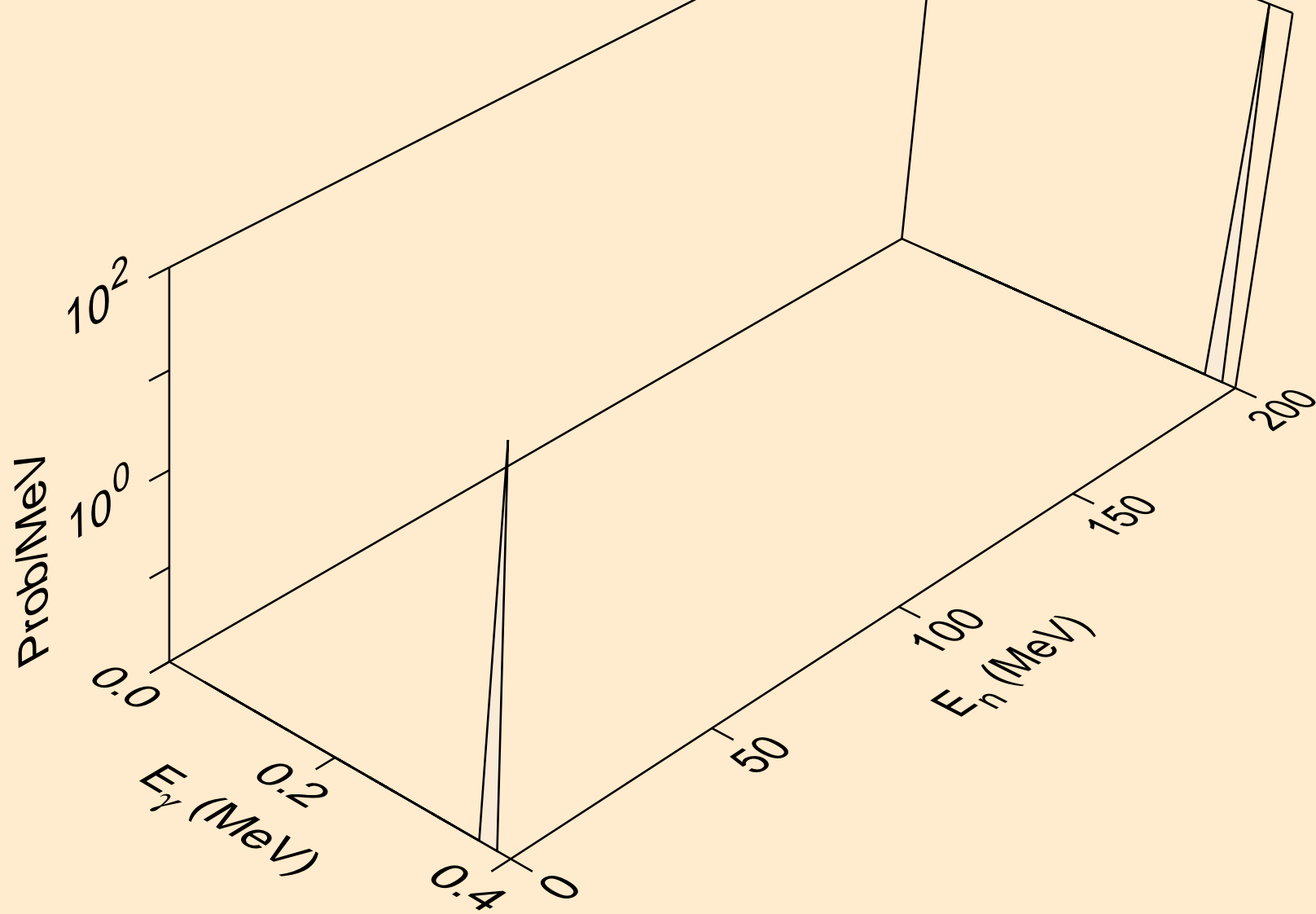

HF177N NEUTRON ACER TENDL-2024 LIBRARY; T=293.6K  
Photon emission for (n,n\*5)

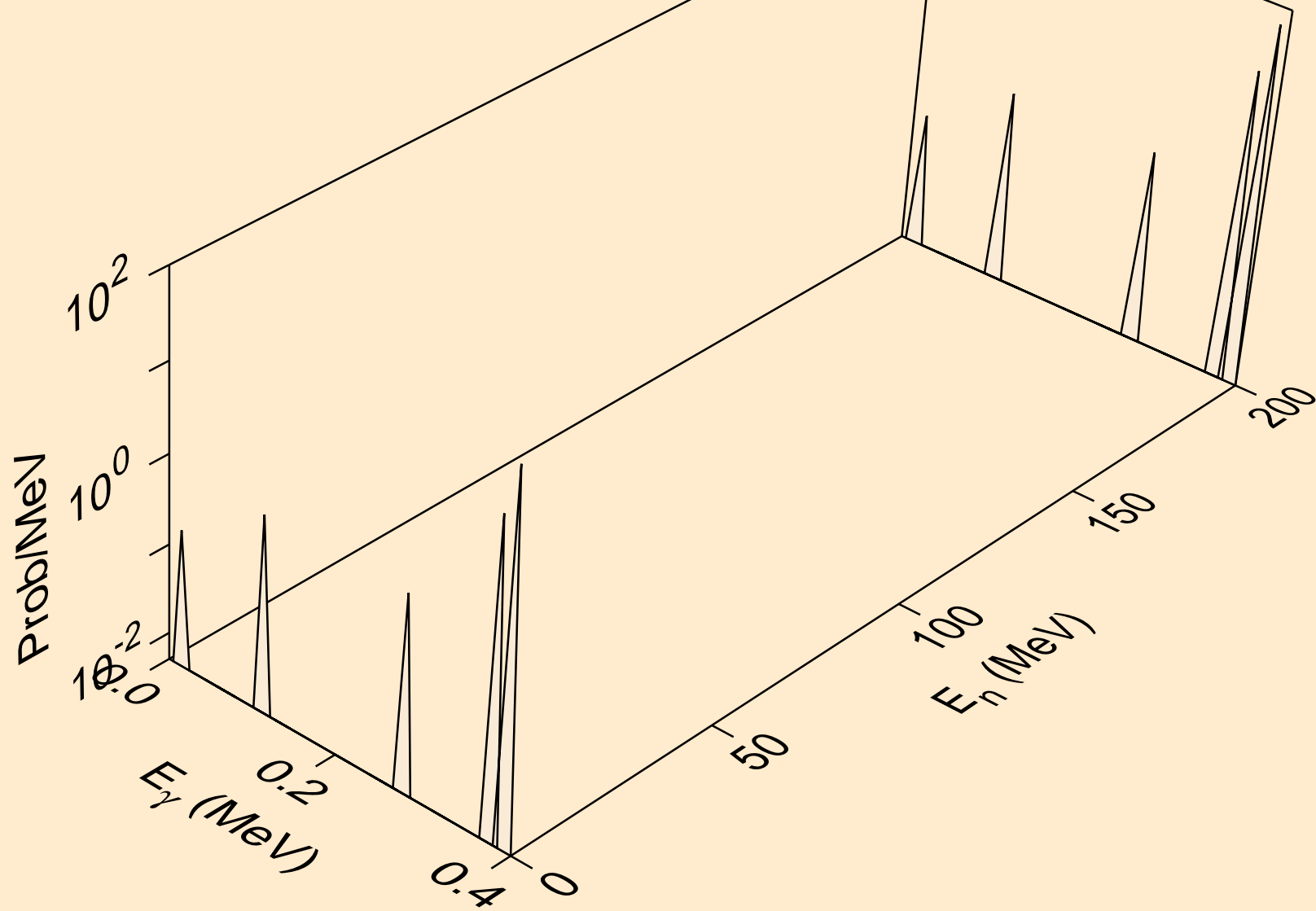

HF177N NEUTRON ACER TENDL-2024 LIBRARY; T=293.6K  
Photon emission for (n,n\*6)

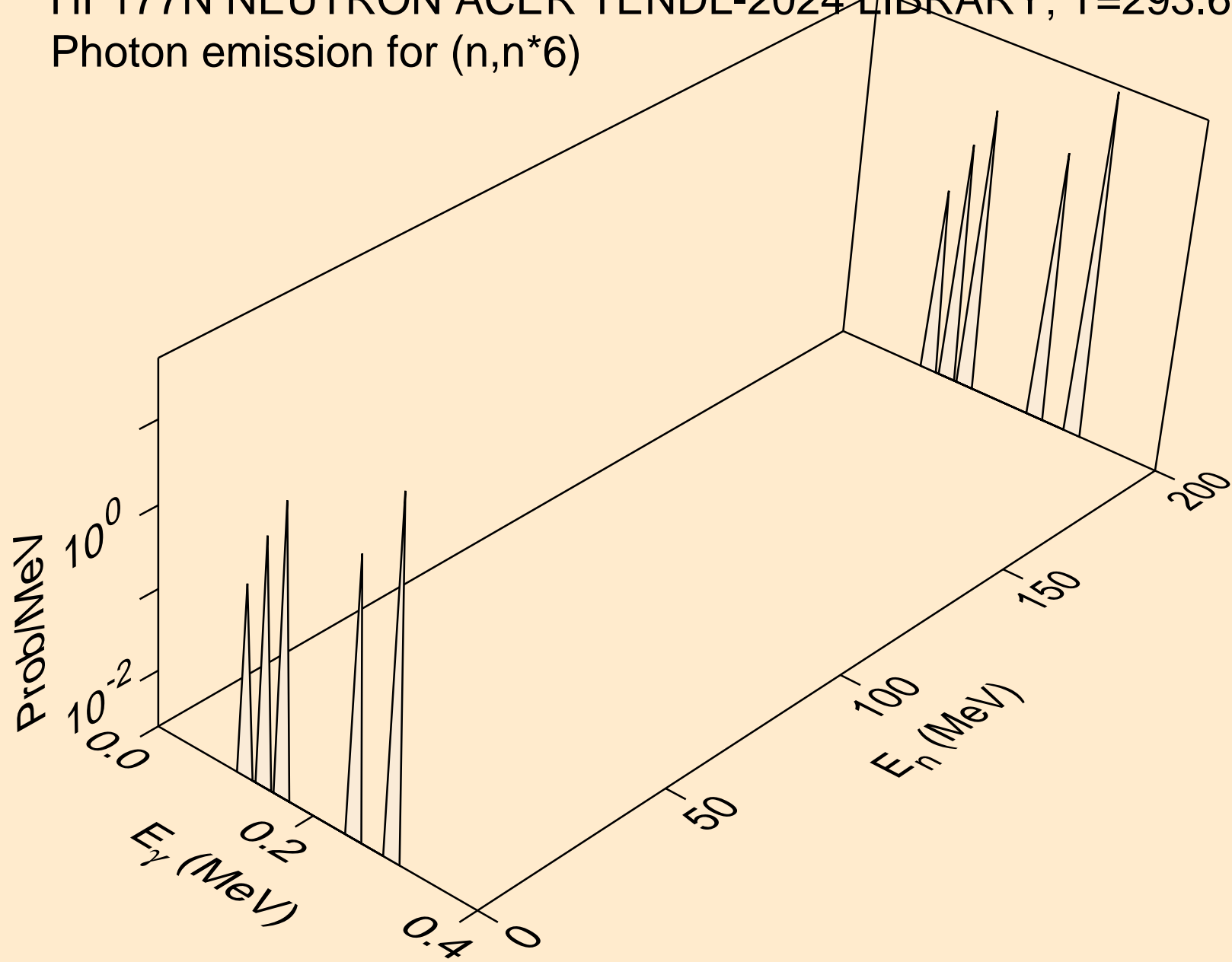

HF177N NEUTRON ACER TENDL-2024 LIBRARY; T=293.6K  
Photon emission for (n,n\*7)

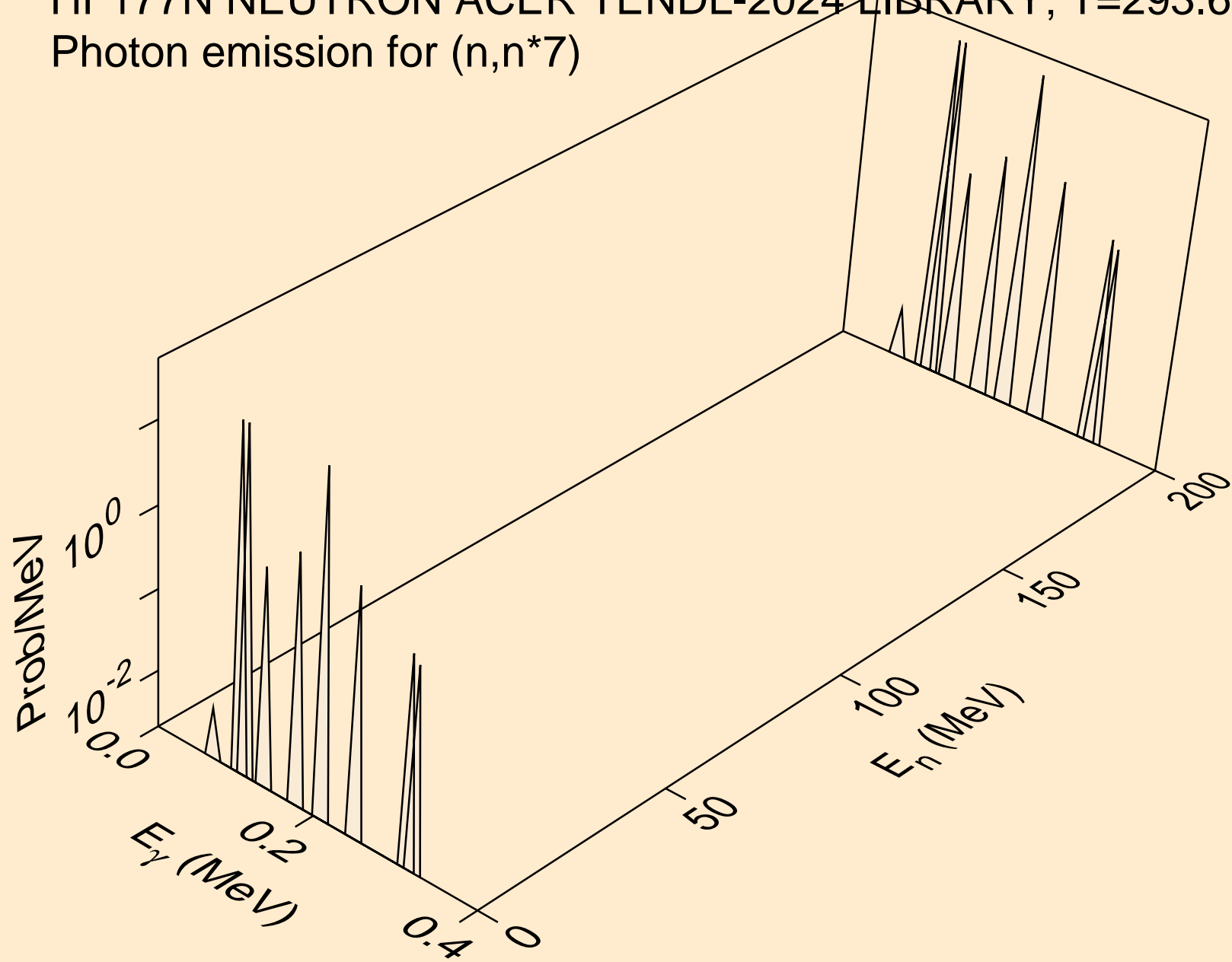

HF177N NEUTRON ACER TENDL-2024 LIBRARY; T=293.6K  
Photon emission for (n,n\*8)

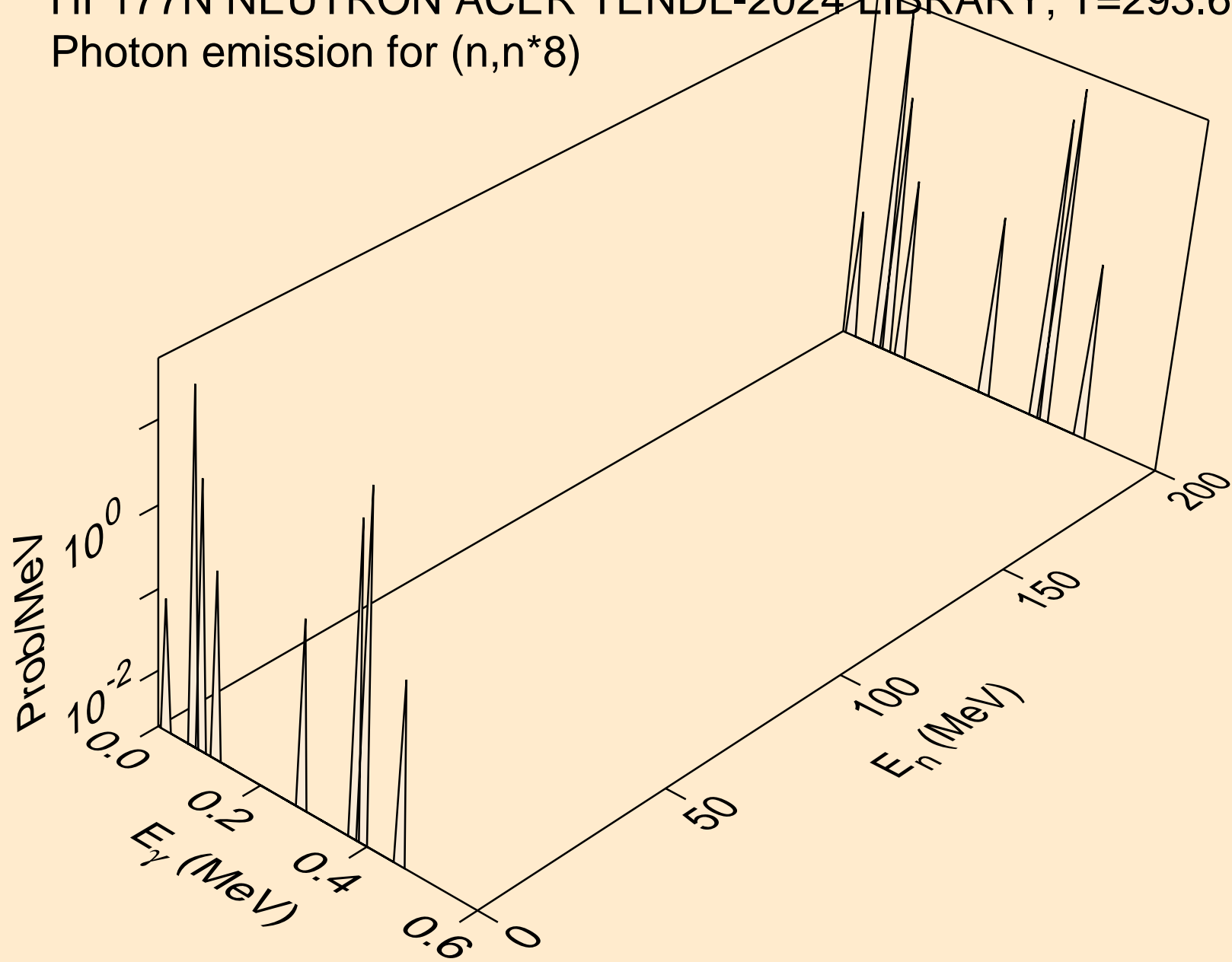

HF177N NEUTRON ACER TENDL-2024 LIBRARY; T=293.6K  
Photon emission for (n,n\*9)

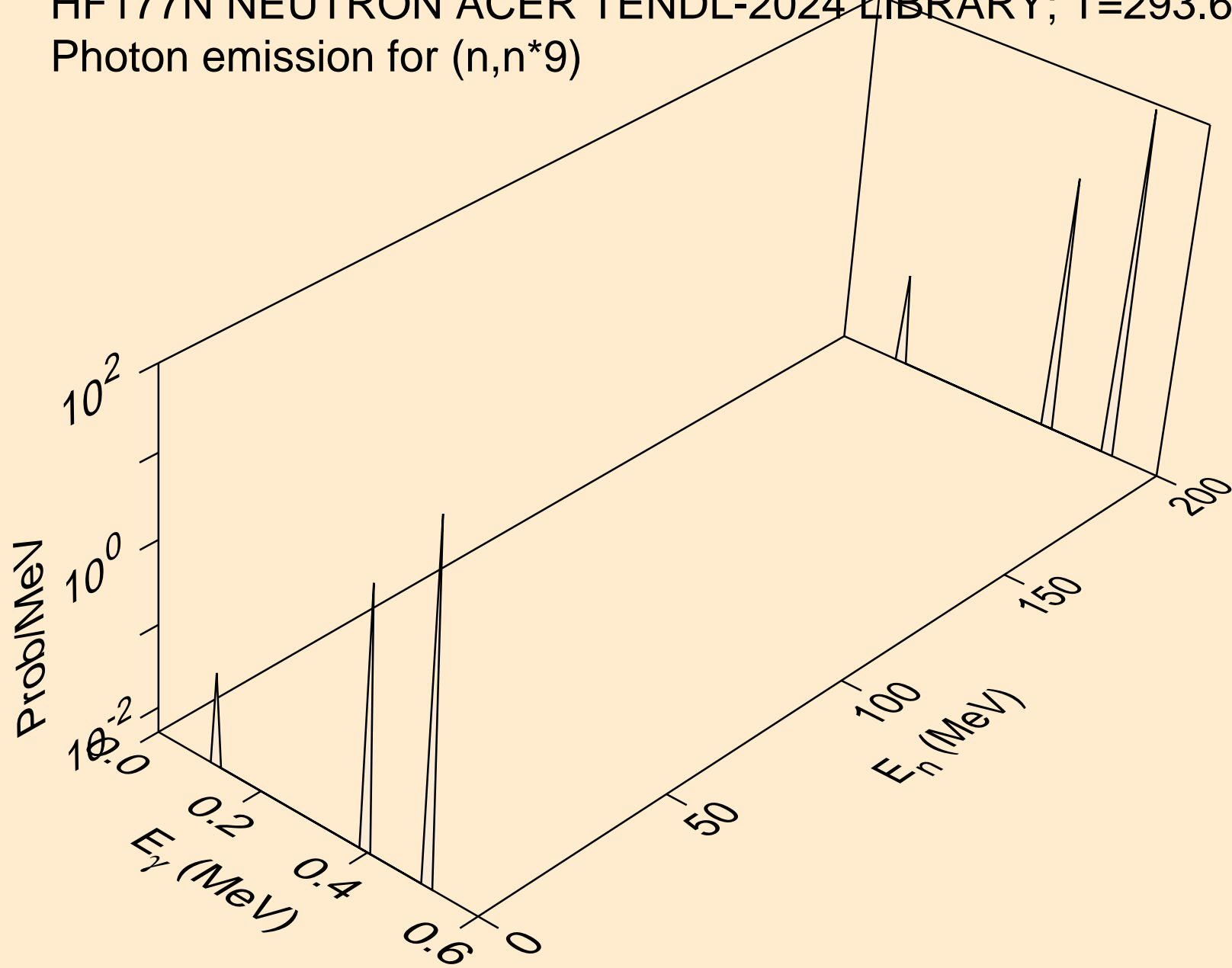

HF177N NEUTRON ACER TENDL-2024 LIBRARY; T=293.6K  
Photon emission for (n,n\*10)

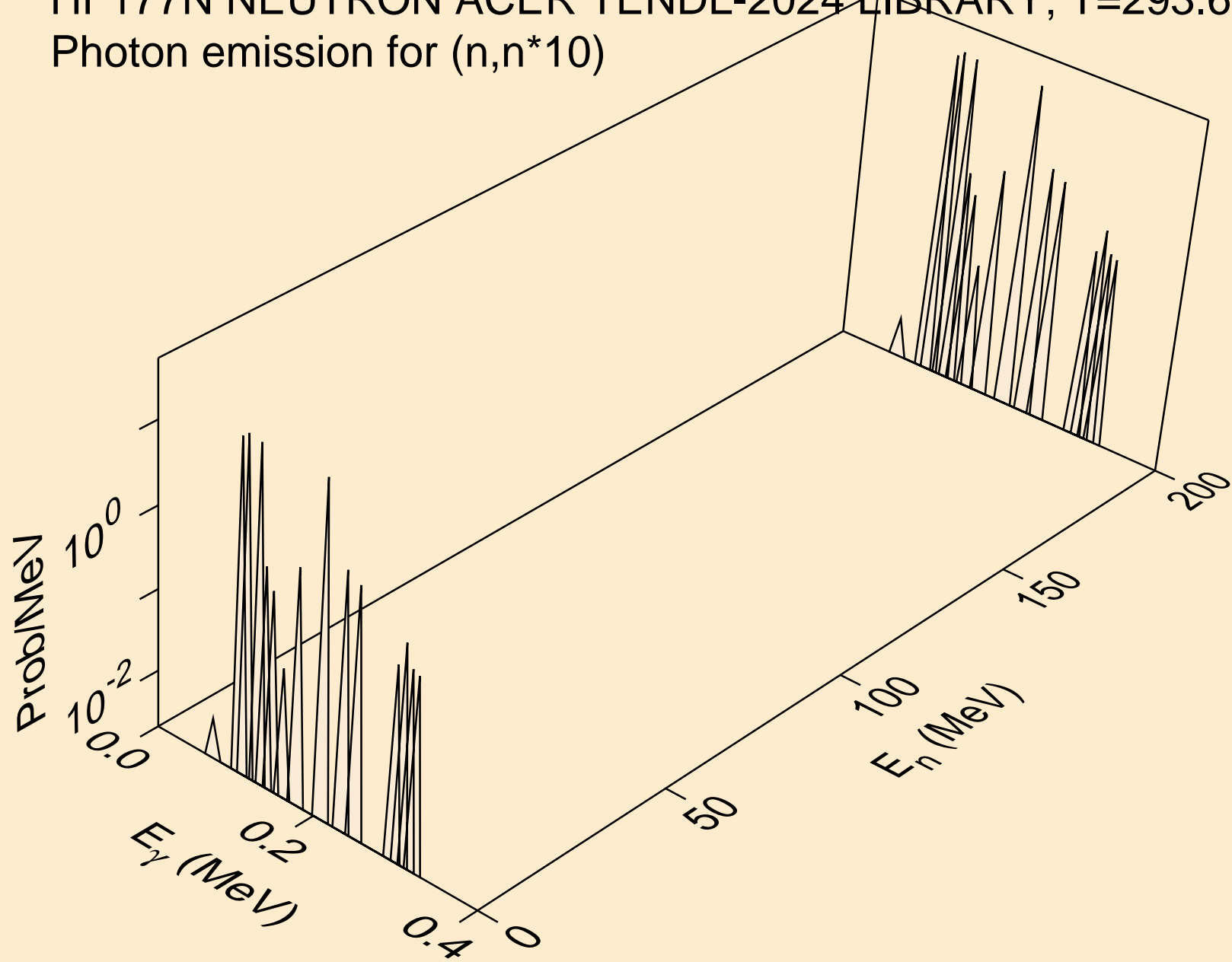

HF177N NEUTRON ACER TENDL-2024 LIBRARY; T=293.6K  
Photon emission for (n,n\*11)

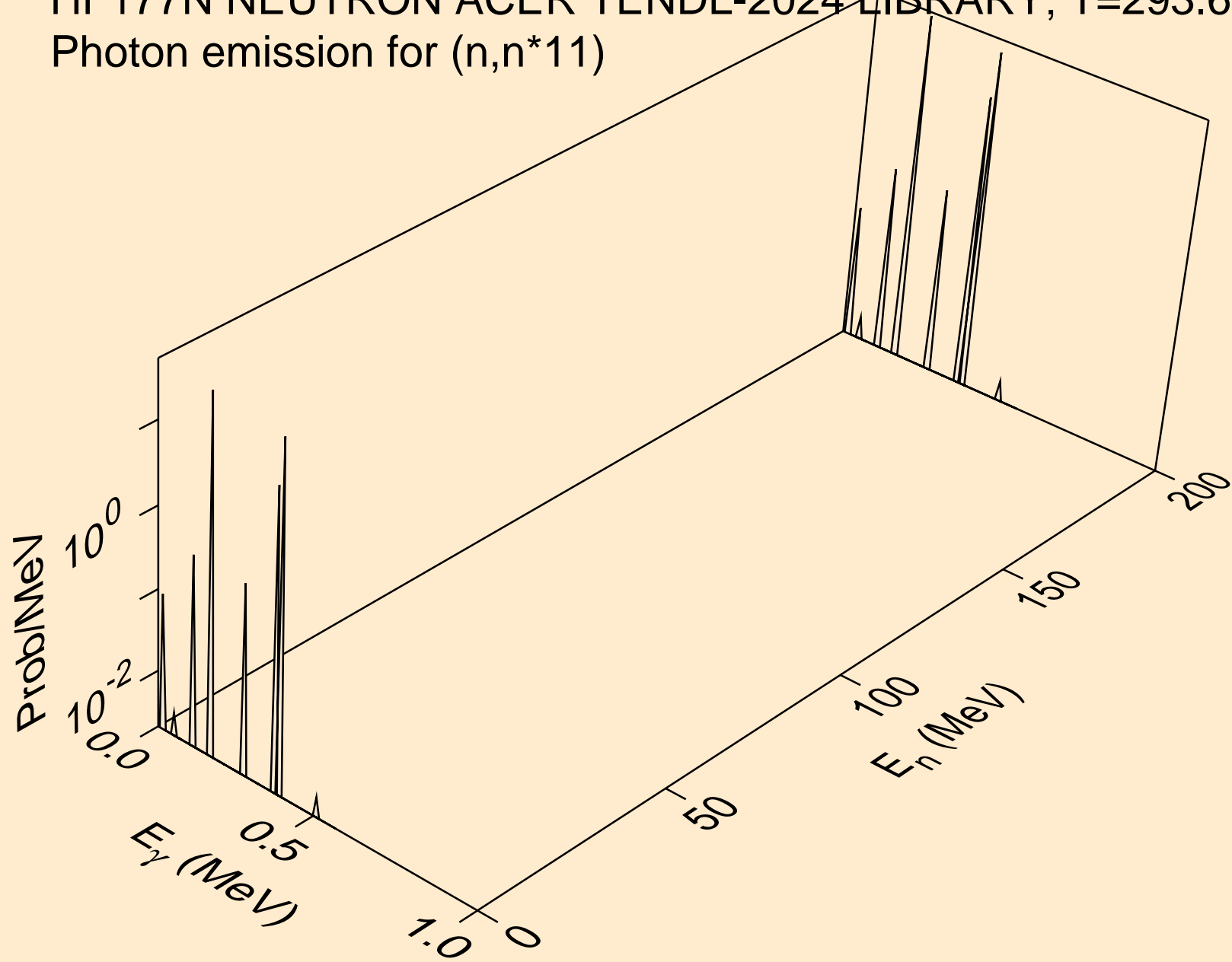

HF177N NEUTRON ACER TENDL-2024 LIBRARY; T=293.6K  
Photon emission for (n,n\*12)

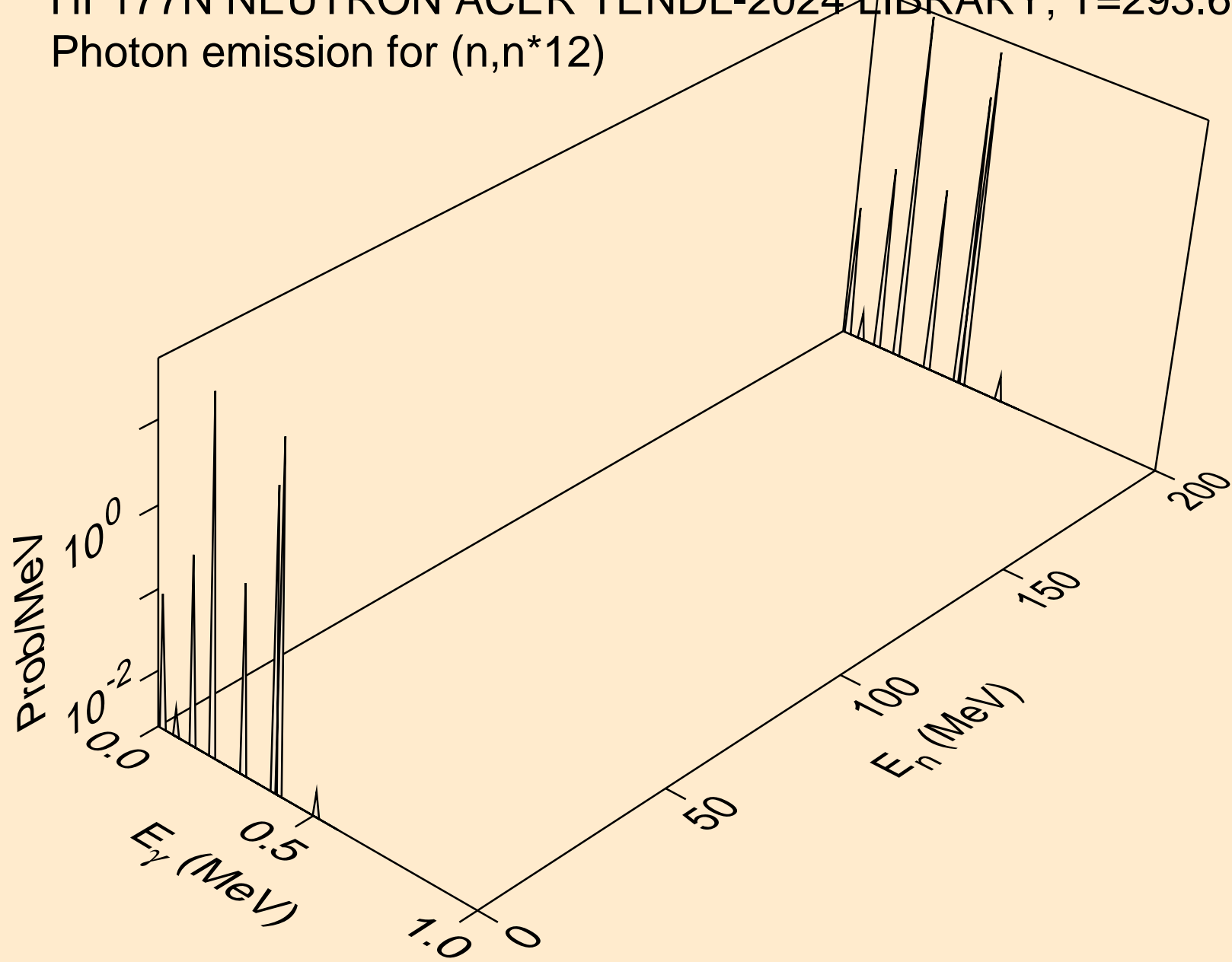

HF177N NEUTRON ACER TENDL-2024 LIBRARY; T=293.6K  
Photon emission for (n,n\*13)

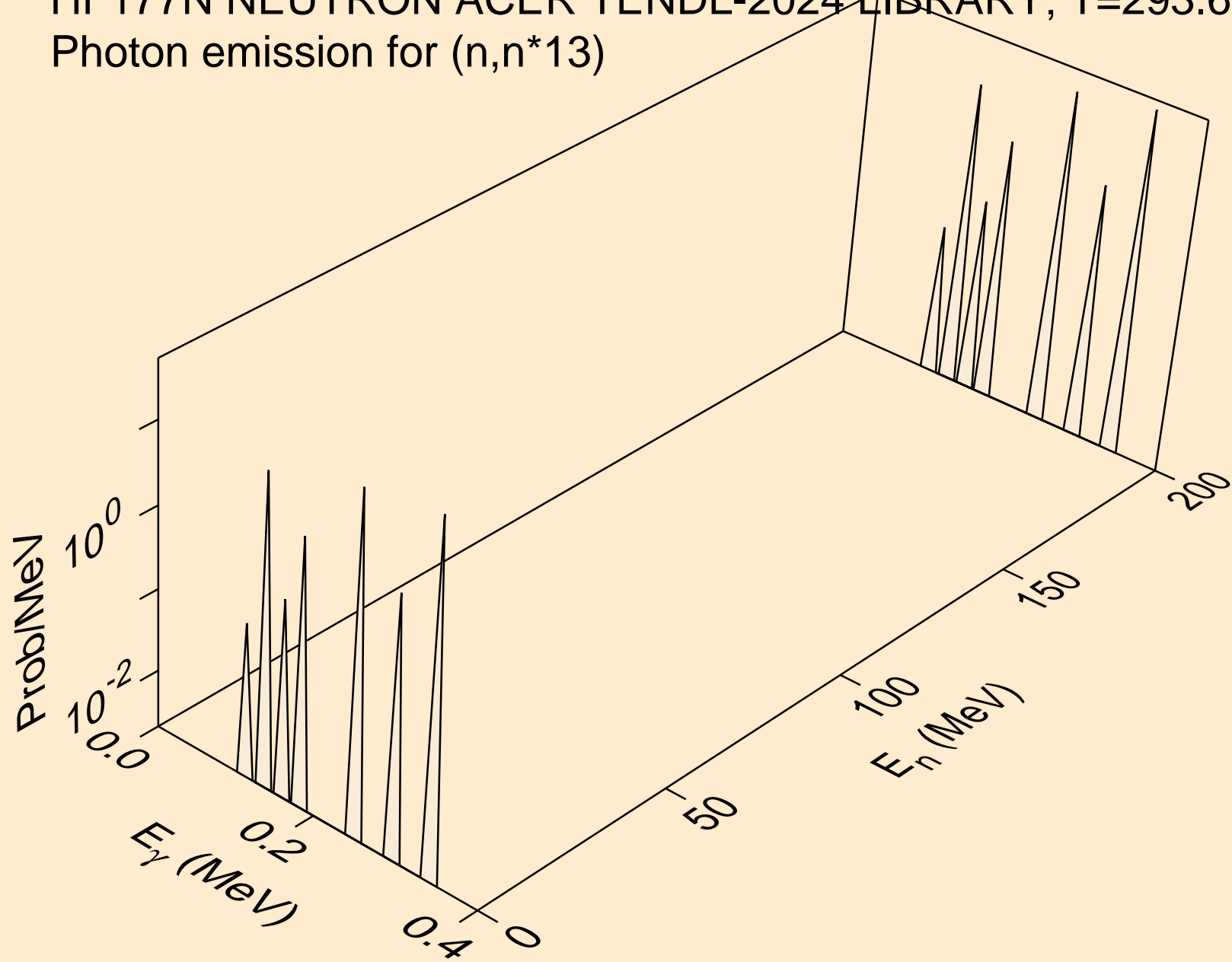

HF177N NEUTRON ACER TENDL-2024 LIBRARY; T=293.6K  
Photon emission for (n,n\*14)

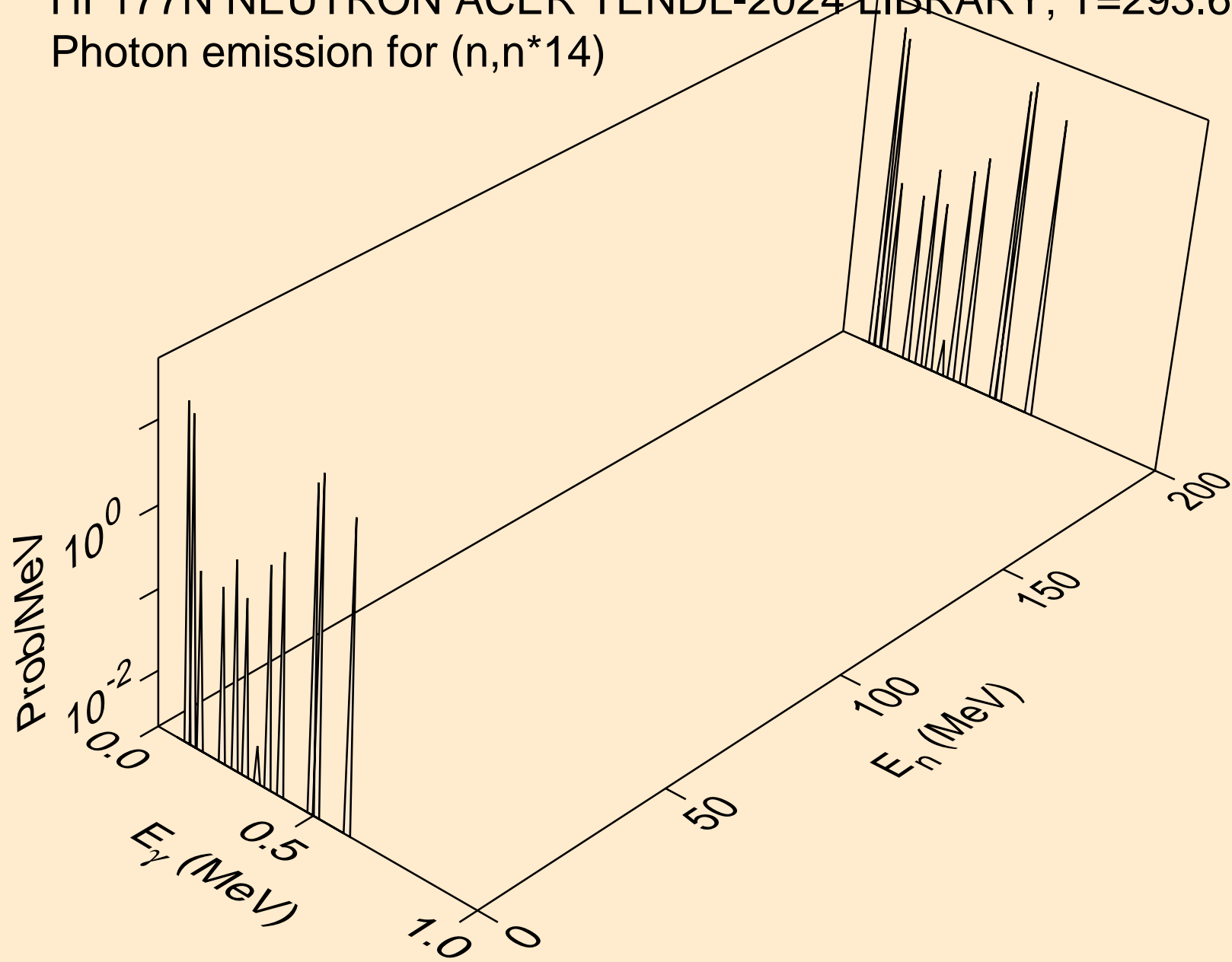

HF177N NEUTRON ACER TENDL-2024 LIBRARY; T=293.6K  
Photon emission for (n,n\*c)

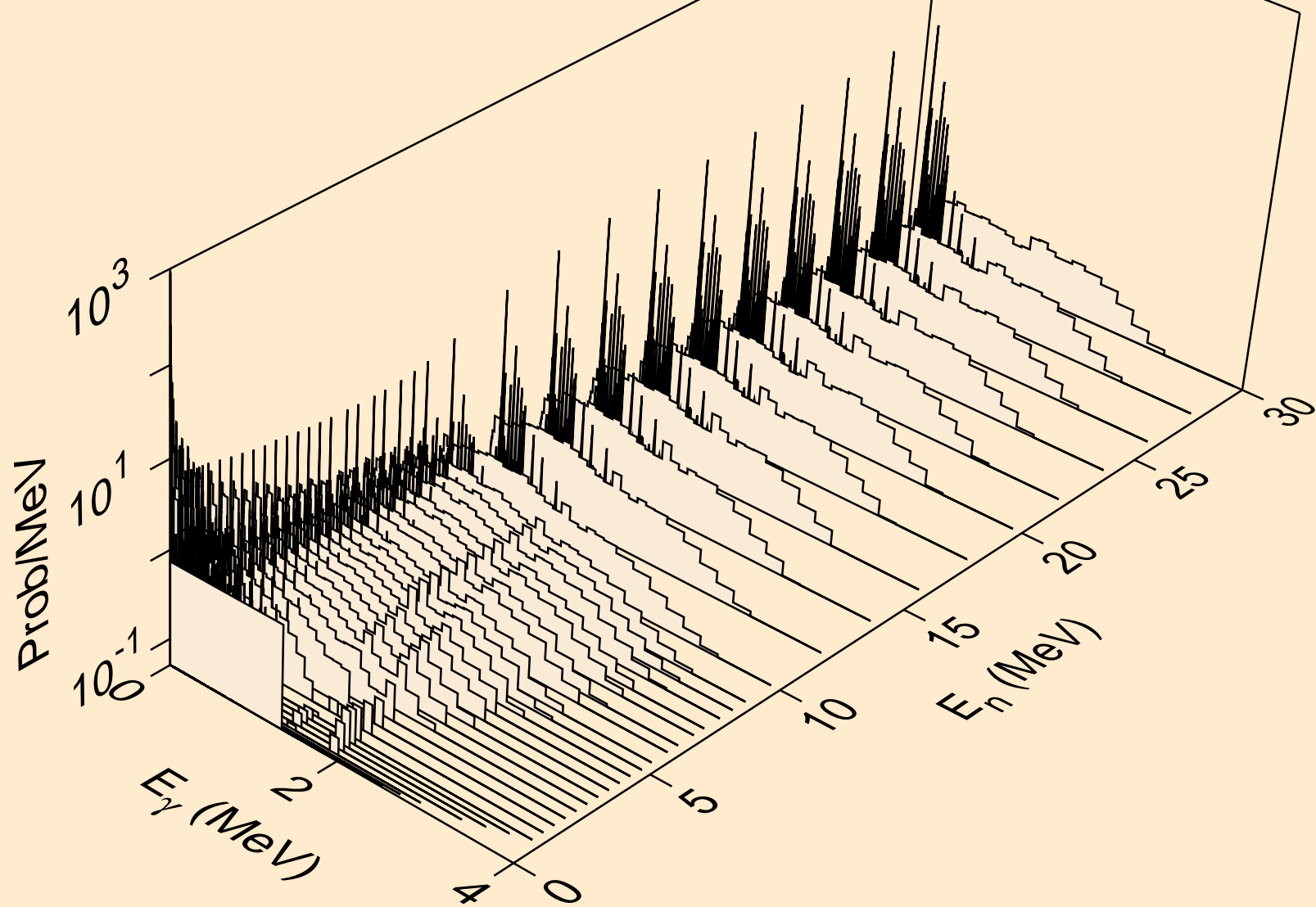

HF177N NEUTRON ACER TENDL-2024 LIBRARY; T=293.6K  
Photon emission for (n,gma)

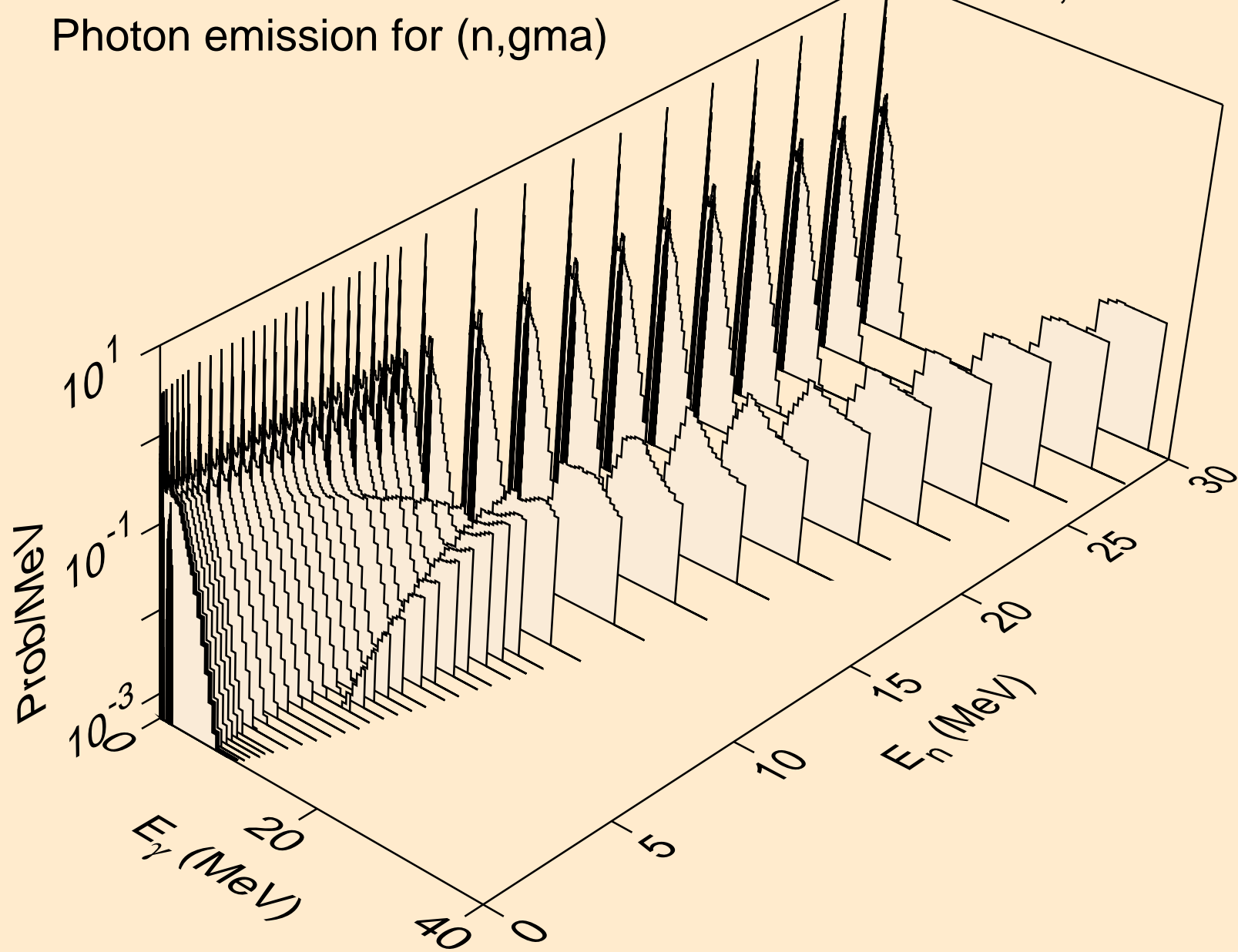

HF177N NEUTRON ACER TENDL-2024 LIBRARY; T=293.6K  
Photon emission for (n,p)

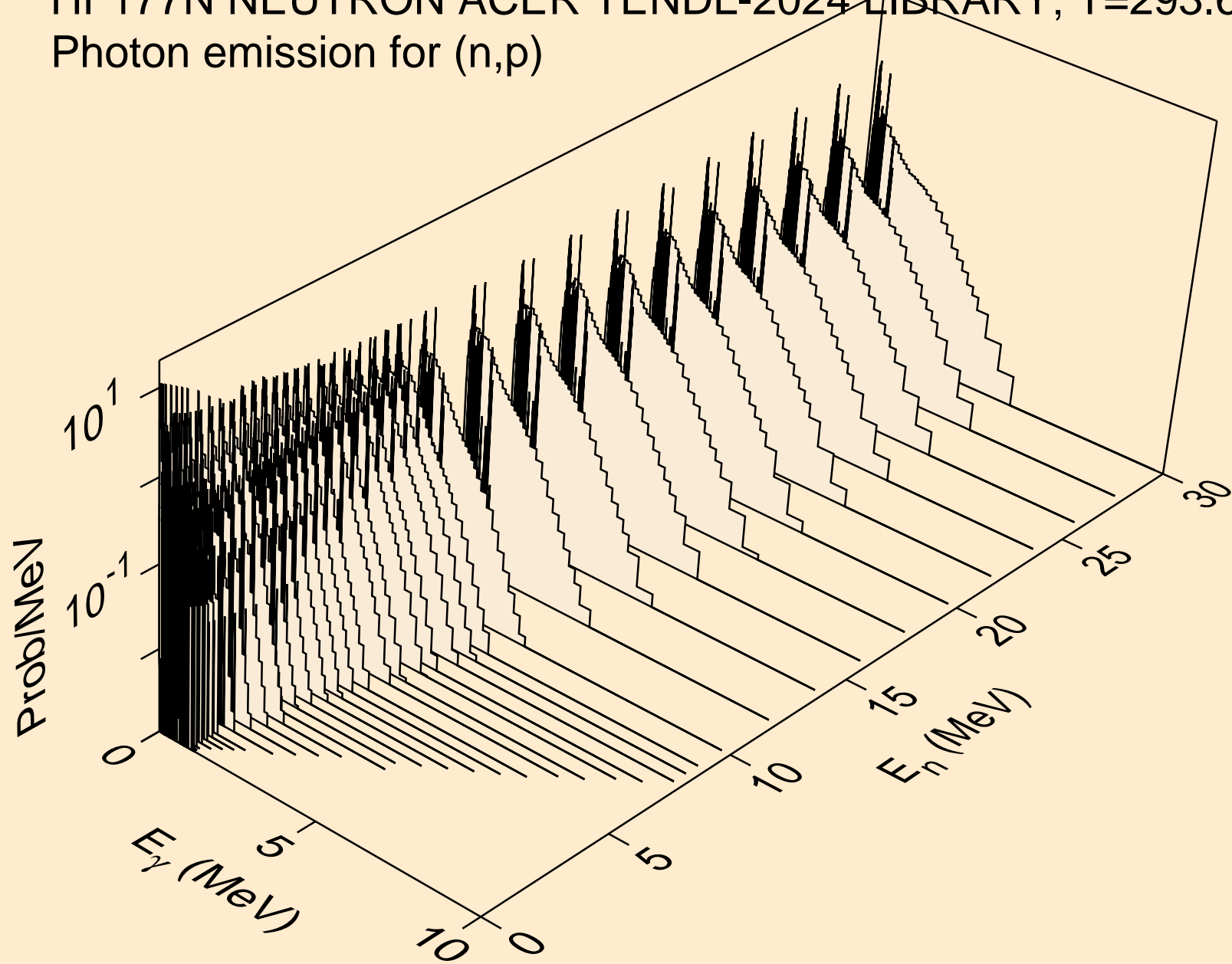

HF177N NEUTRON ACER TENDL-2024 LIBRARY; T=293.6K  
Photon emission for (n,d)

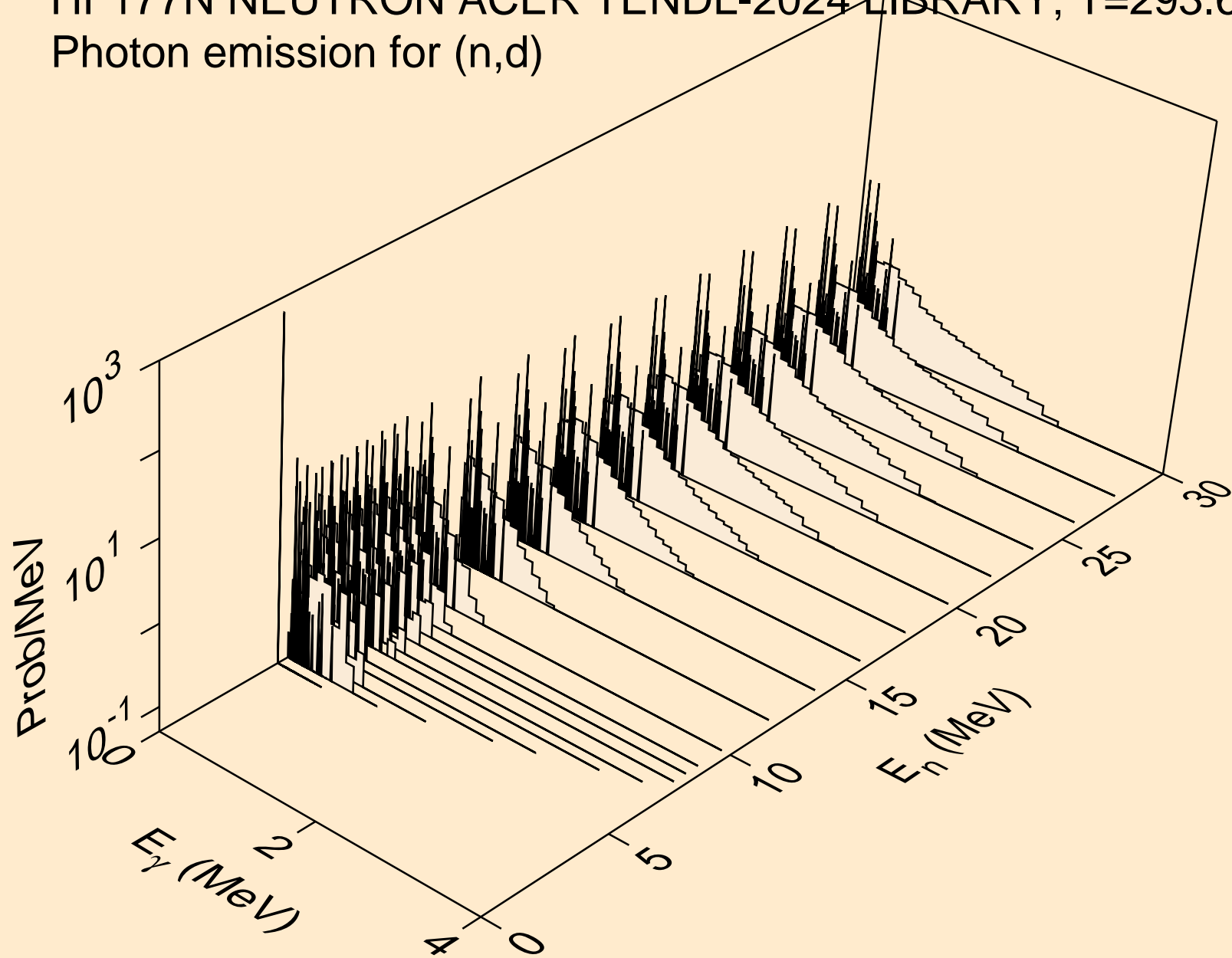

HF177N NEUTRON ACER TENDL-2024 LIBRARY; T=293.6K  
Photon emission for (n,t)

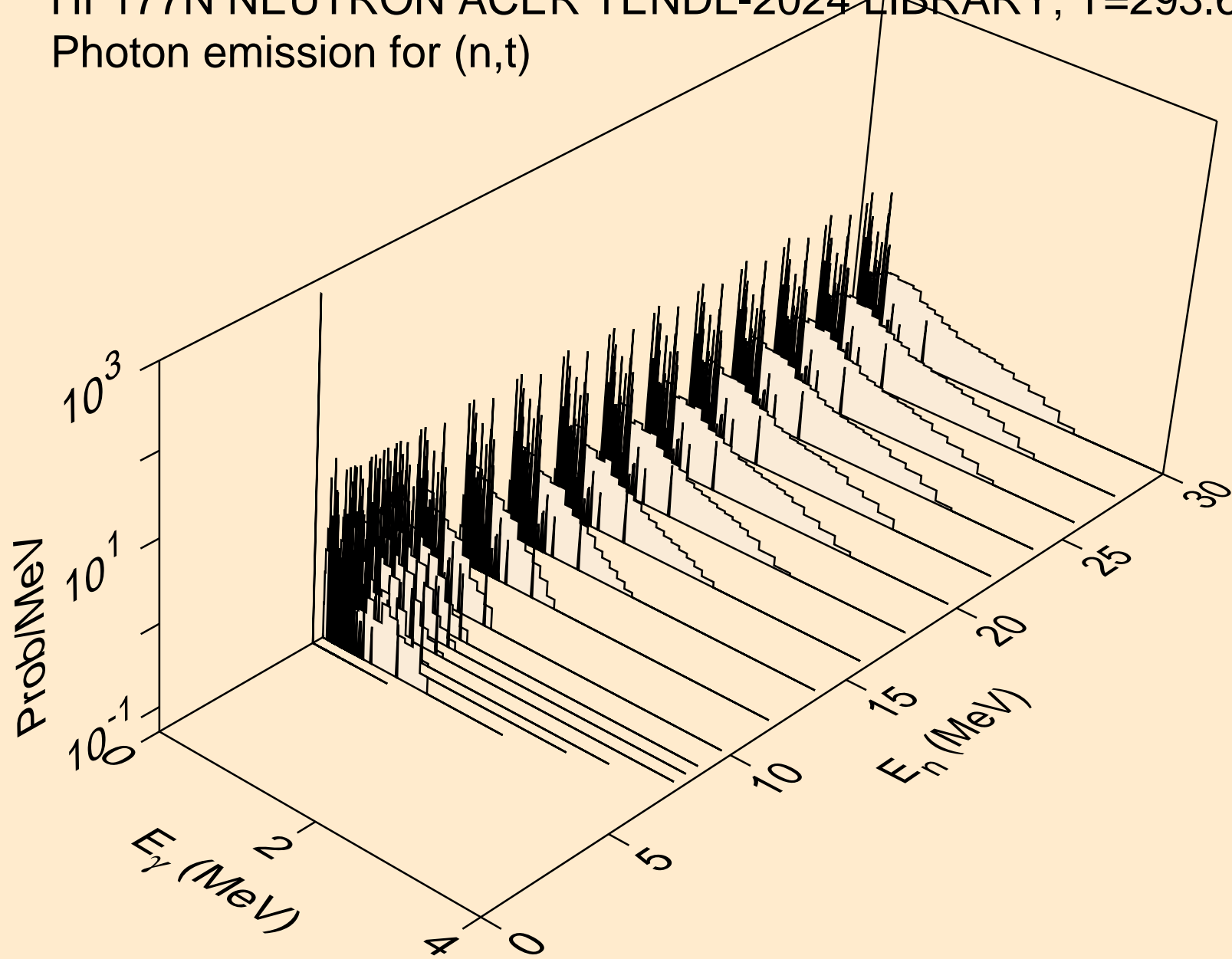

HF177N NEUTRON ACER TENDL-2024 LIBRARY; T=293.6K  
Photon emission for (n,he3)

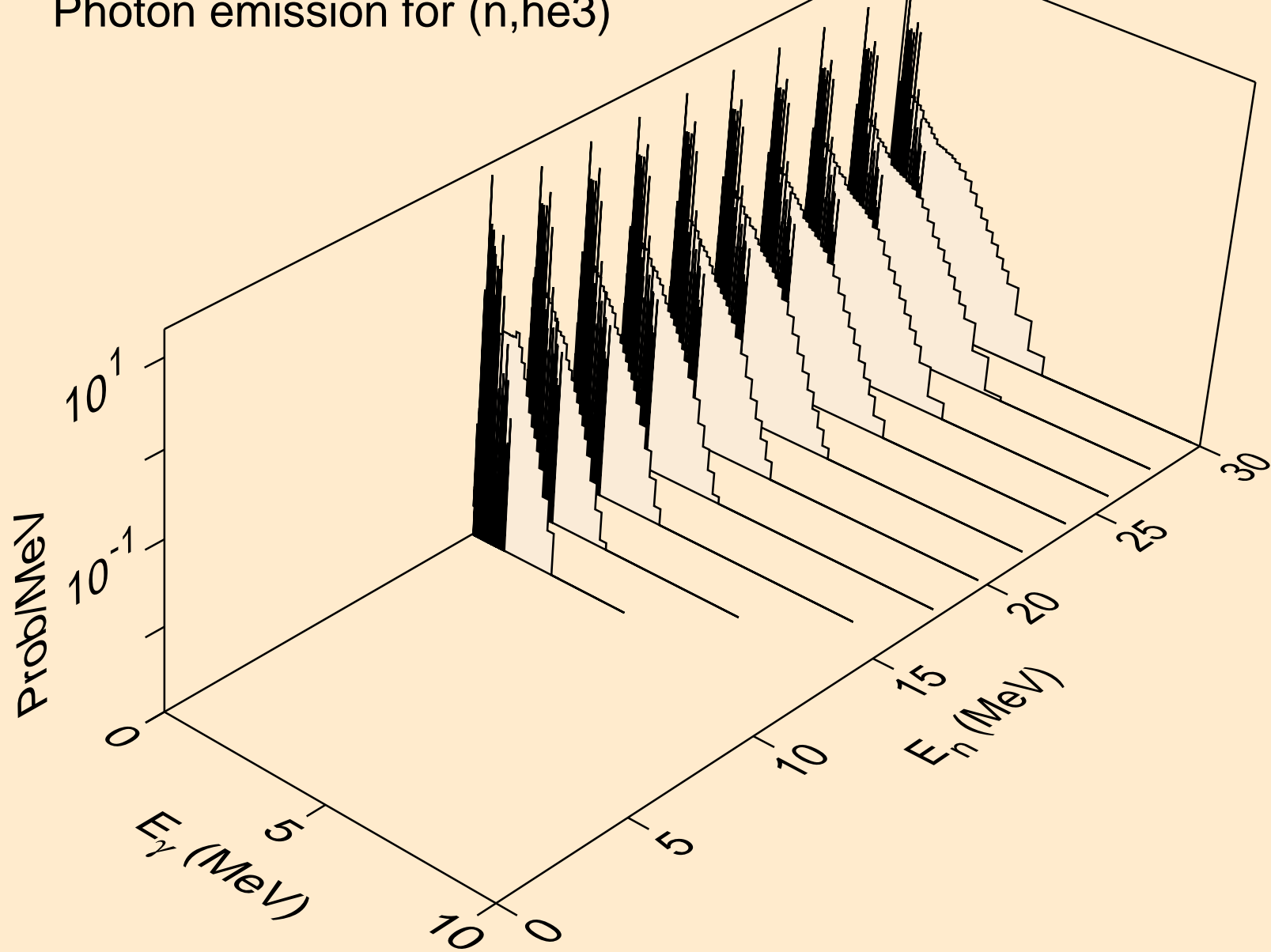

HF177N NEUTRON ACER TENDL-2024 LIBRARY; T=293.6K  
Photon emission for (n,a)

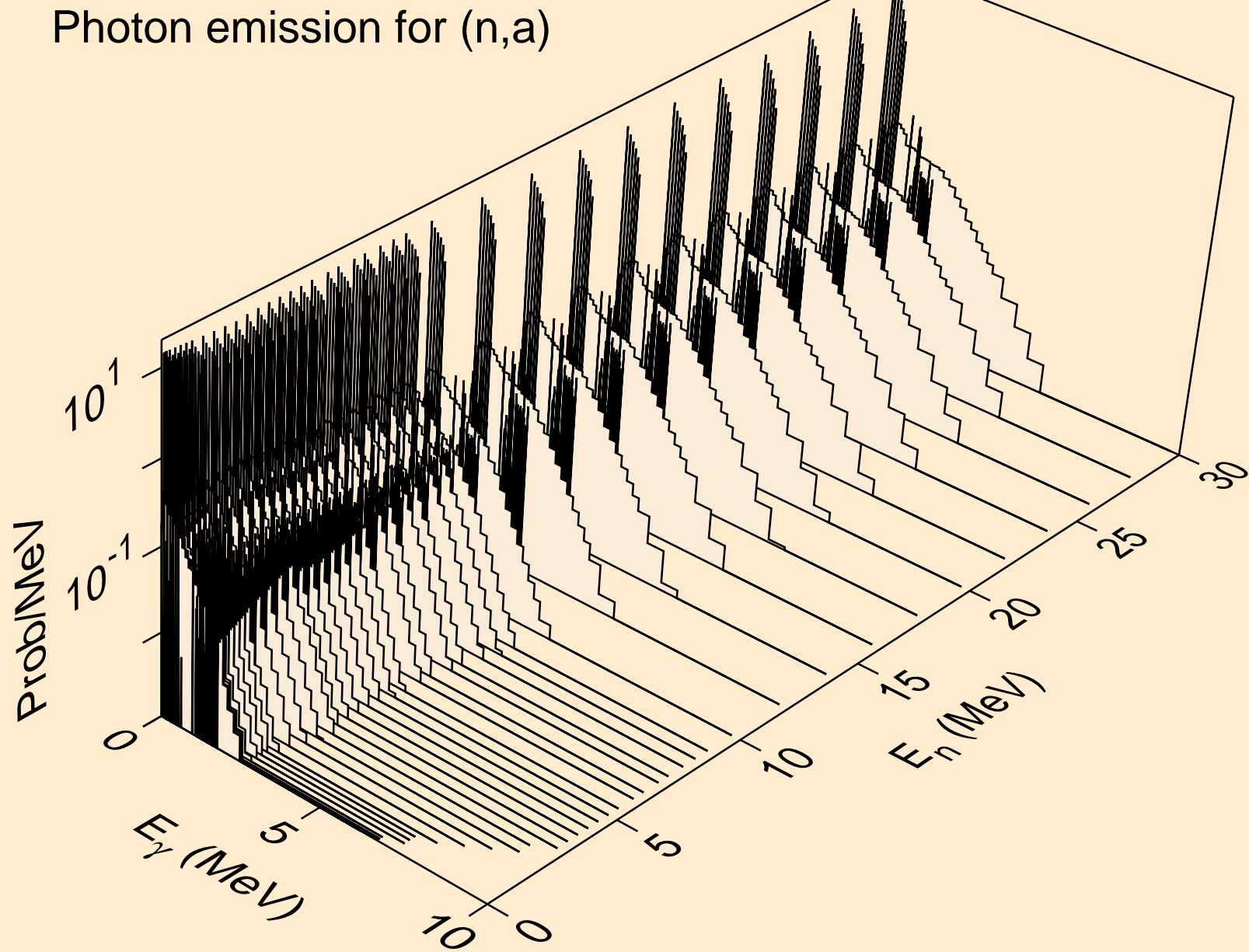

HF177N NEUTRON ACER TENDL-2024 LIBRARY; T=293.6K  
Photon emission for (n,2a)

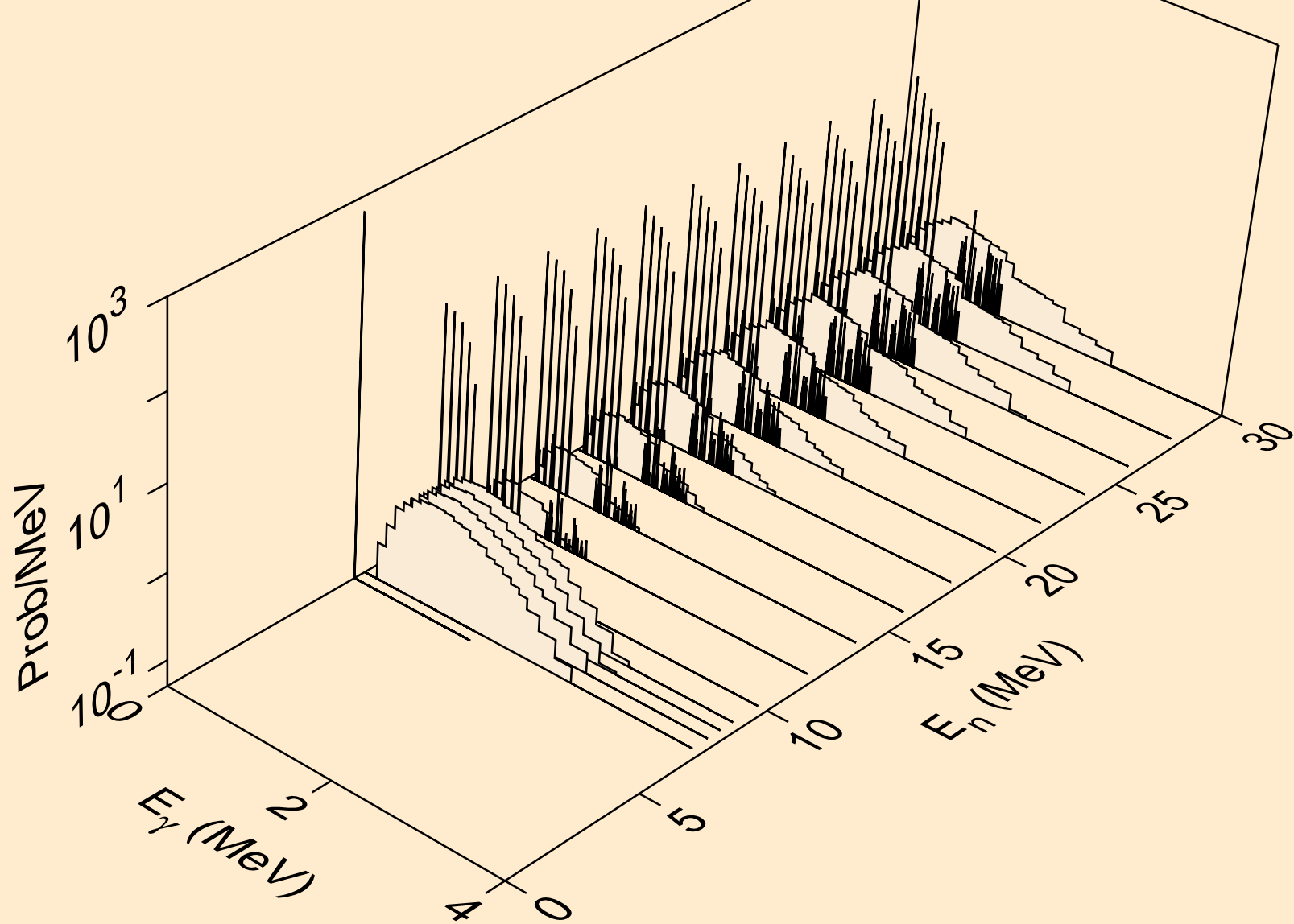

HF177N NEUTRON ACER TENDL-2024 LIBRARY; T=293.6K  
Photon emission for (n,2p)

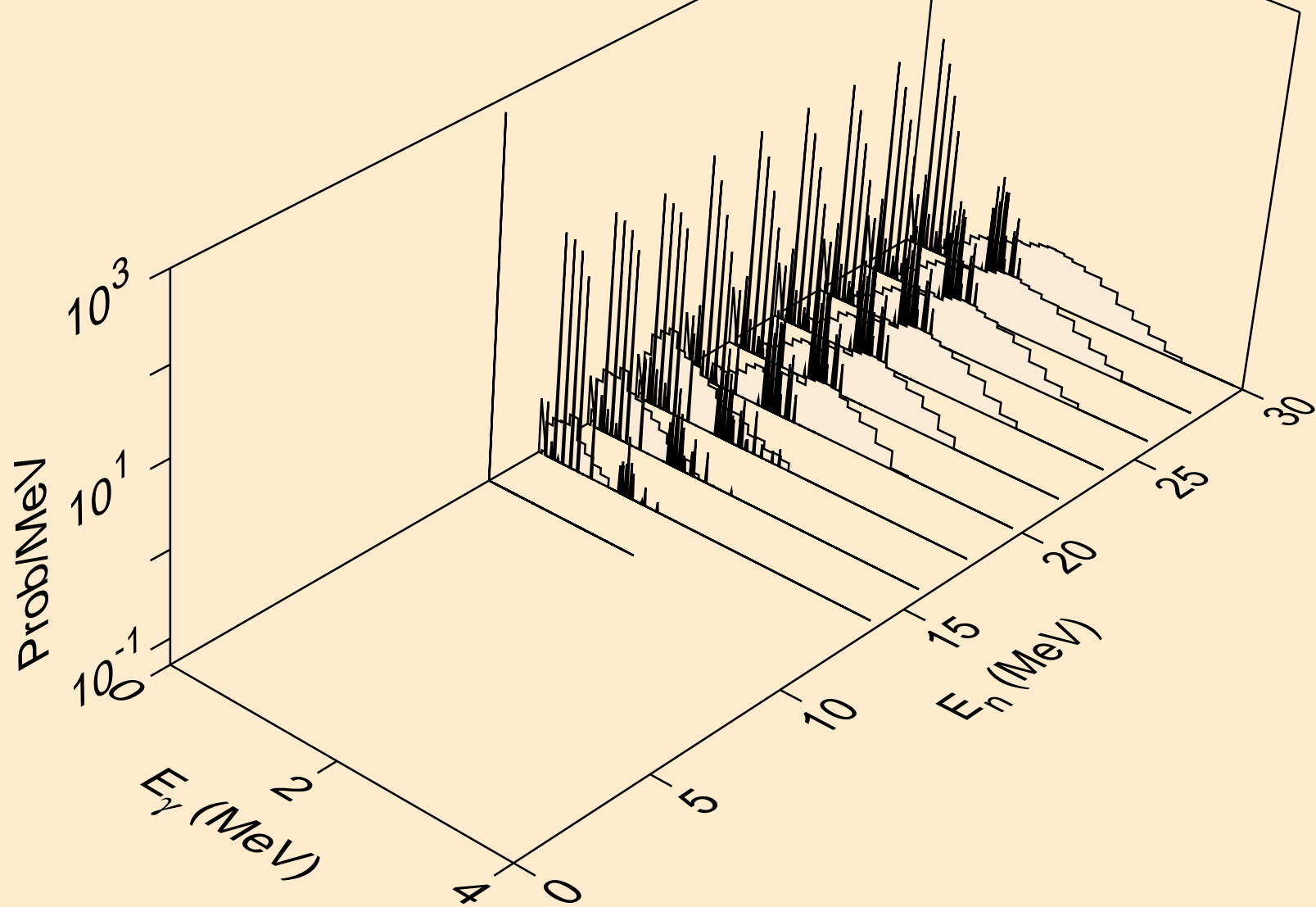

HF177N NEUTRON ACER TENDL-2024 LIBRARY; T=293.6K  
Photon emission for (n,p $\alpha$ )

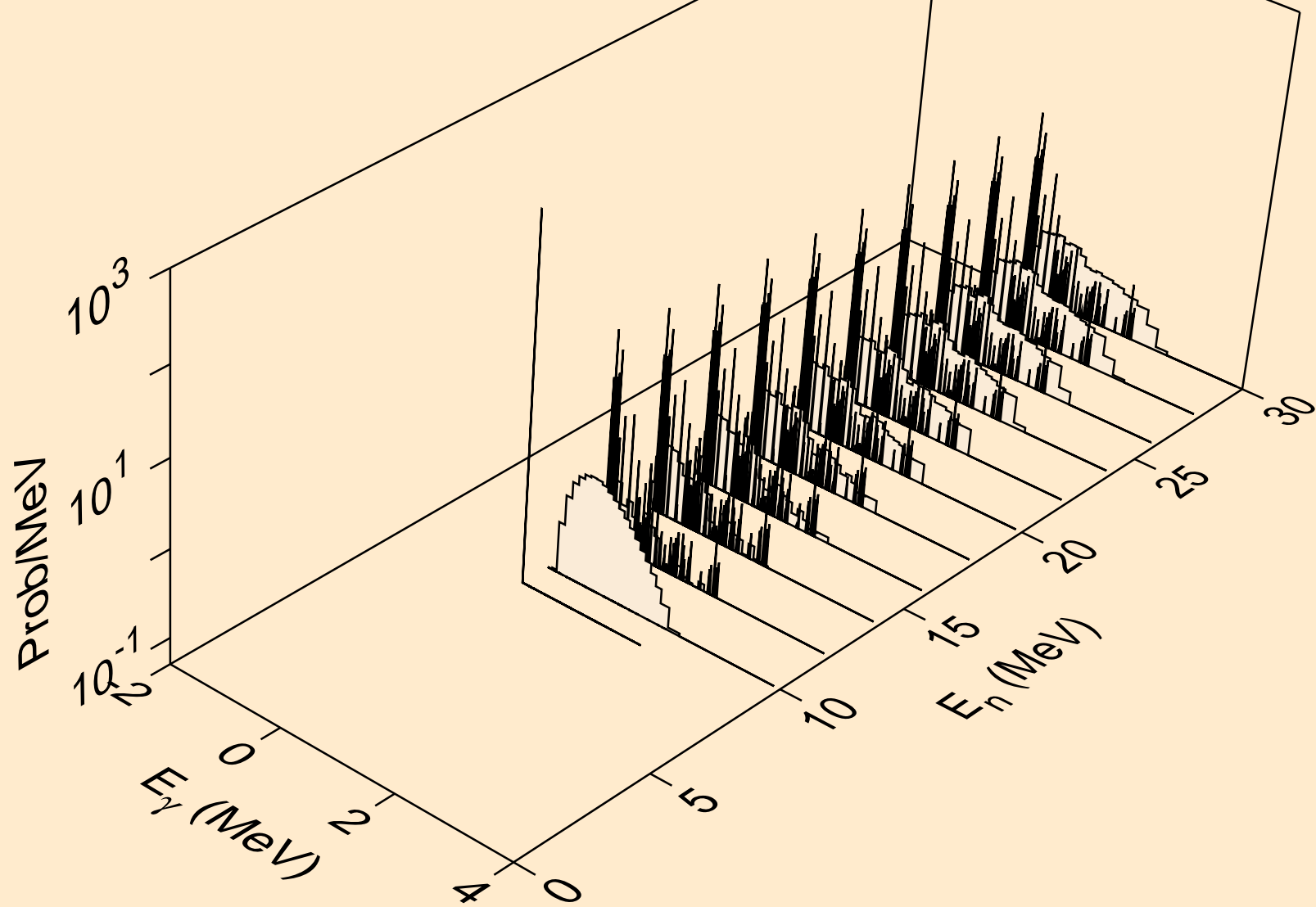

HF177N NEUTRON ACER TENDL-2024 LIBRARY; T=293.6K  
Photon emission for (n,pd)

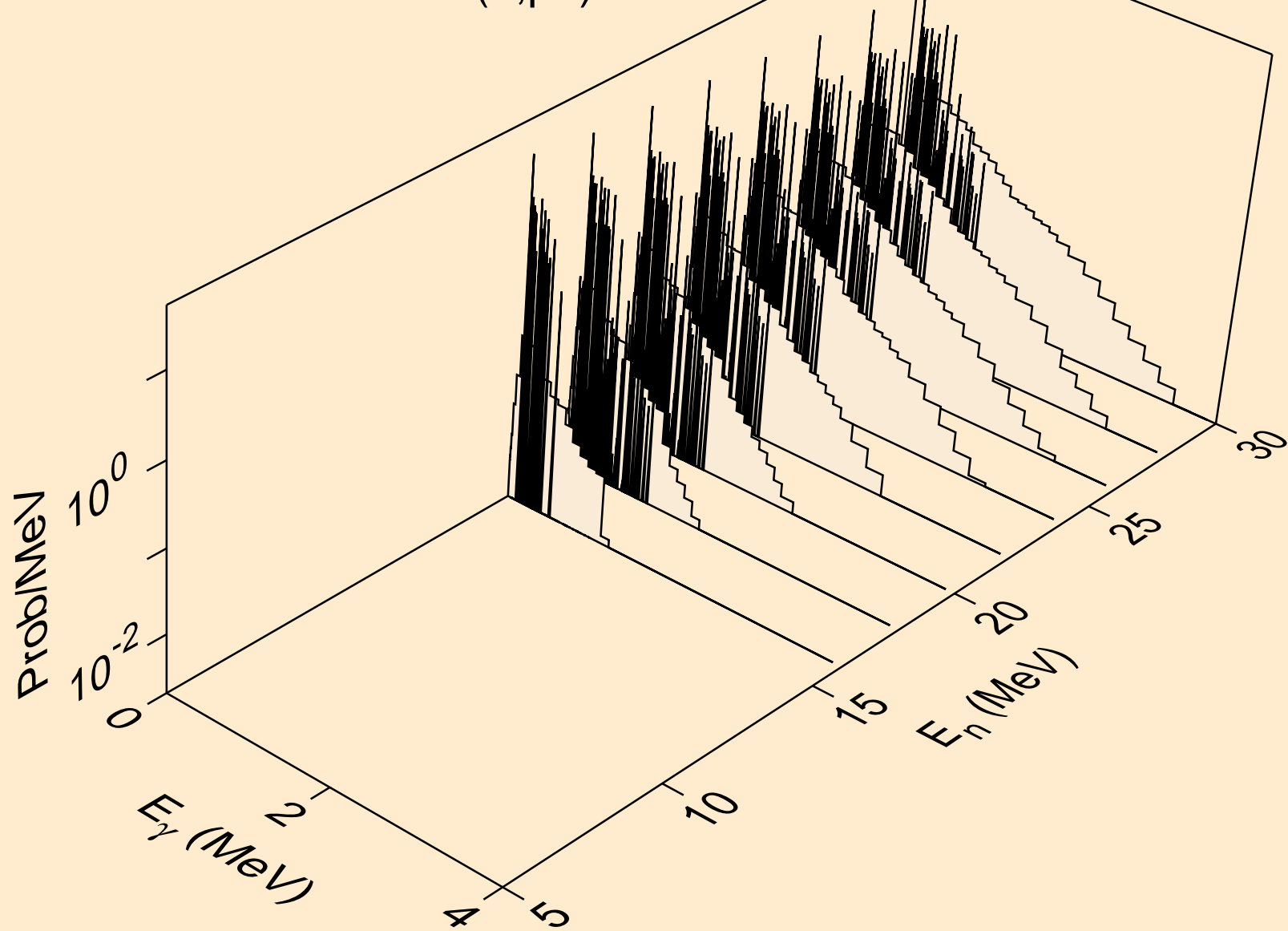

HF177N NEUTRON ACER TENDL-2024 LIBRARY; T=293.6K  
Photon emission for (n,pt)

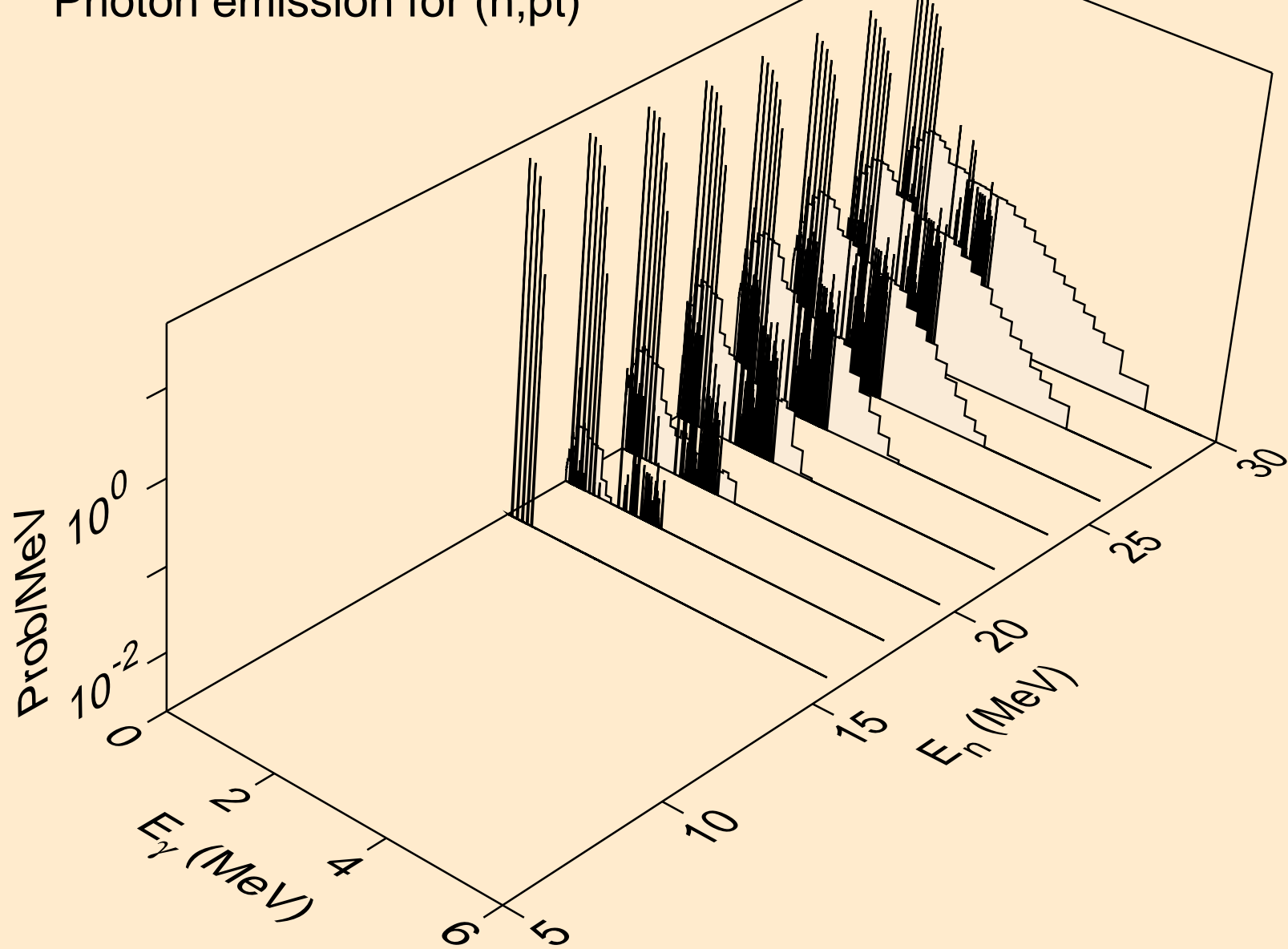

HF177N NEUTRON ACER TENDL-2024 LIBRARY; T=293.6K  
Photon emission for (n,da)

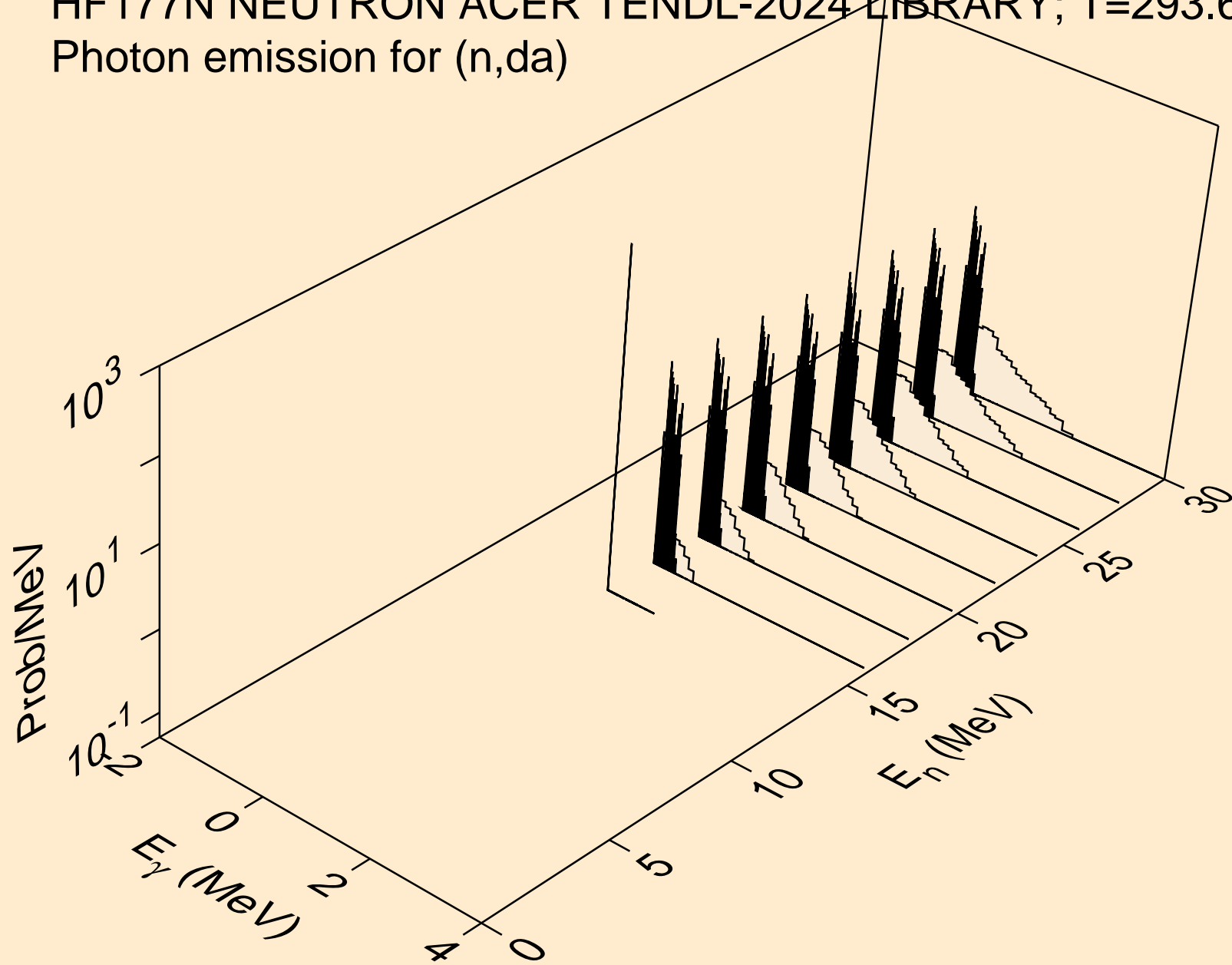

HF177N NEUTRON ACER TENDL-2024 LIBRARY; T=293.6K  
thermal capture photon spectrum

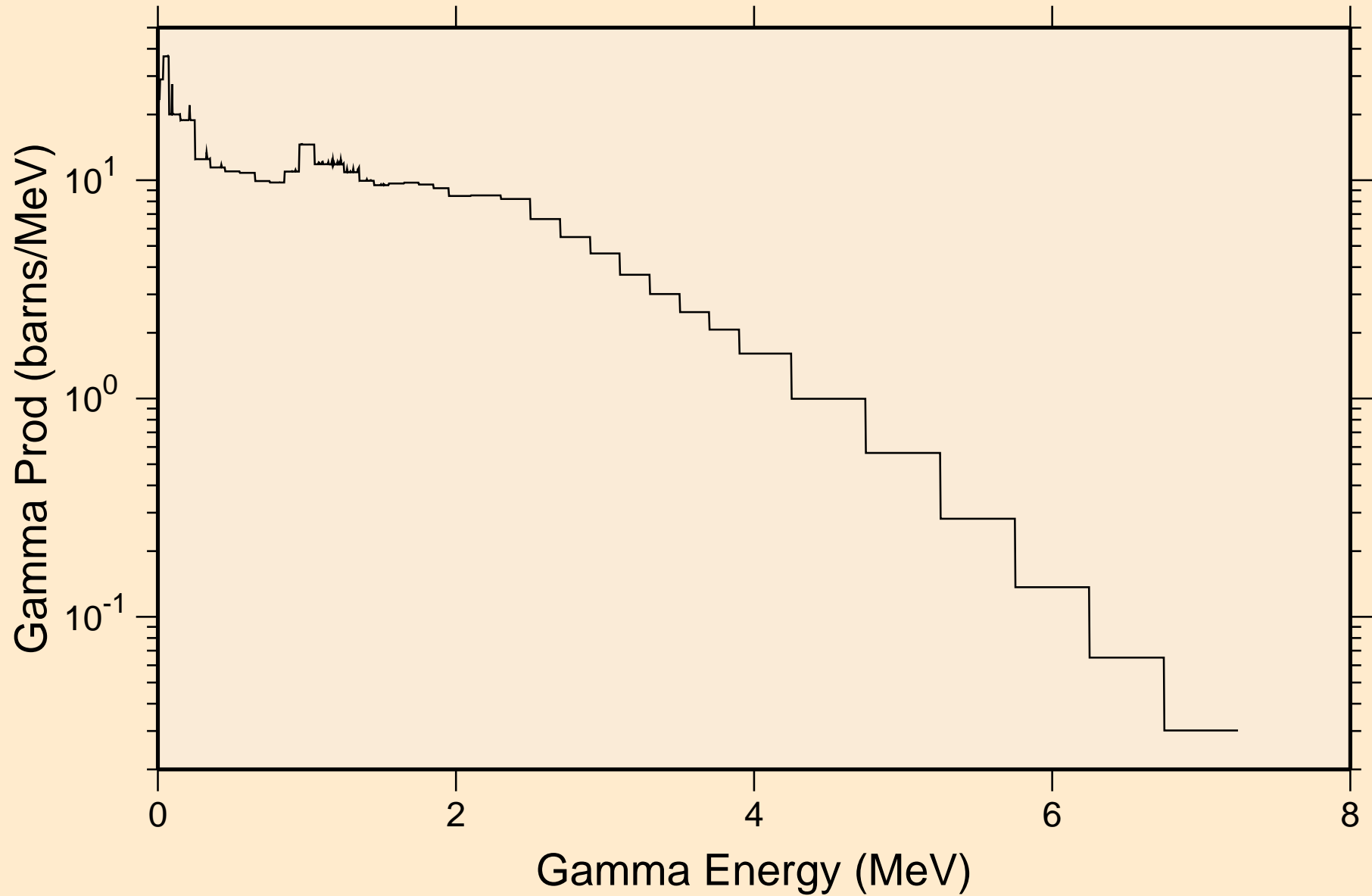

HF177N NEUTRON ACER TENDL-2024 LIBRARY; T=293.6K  
14 MeV photon spectrum

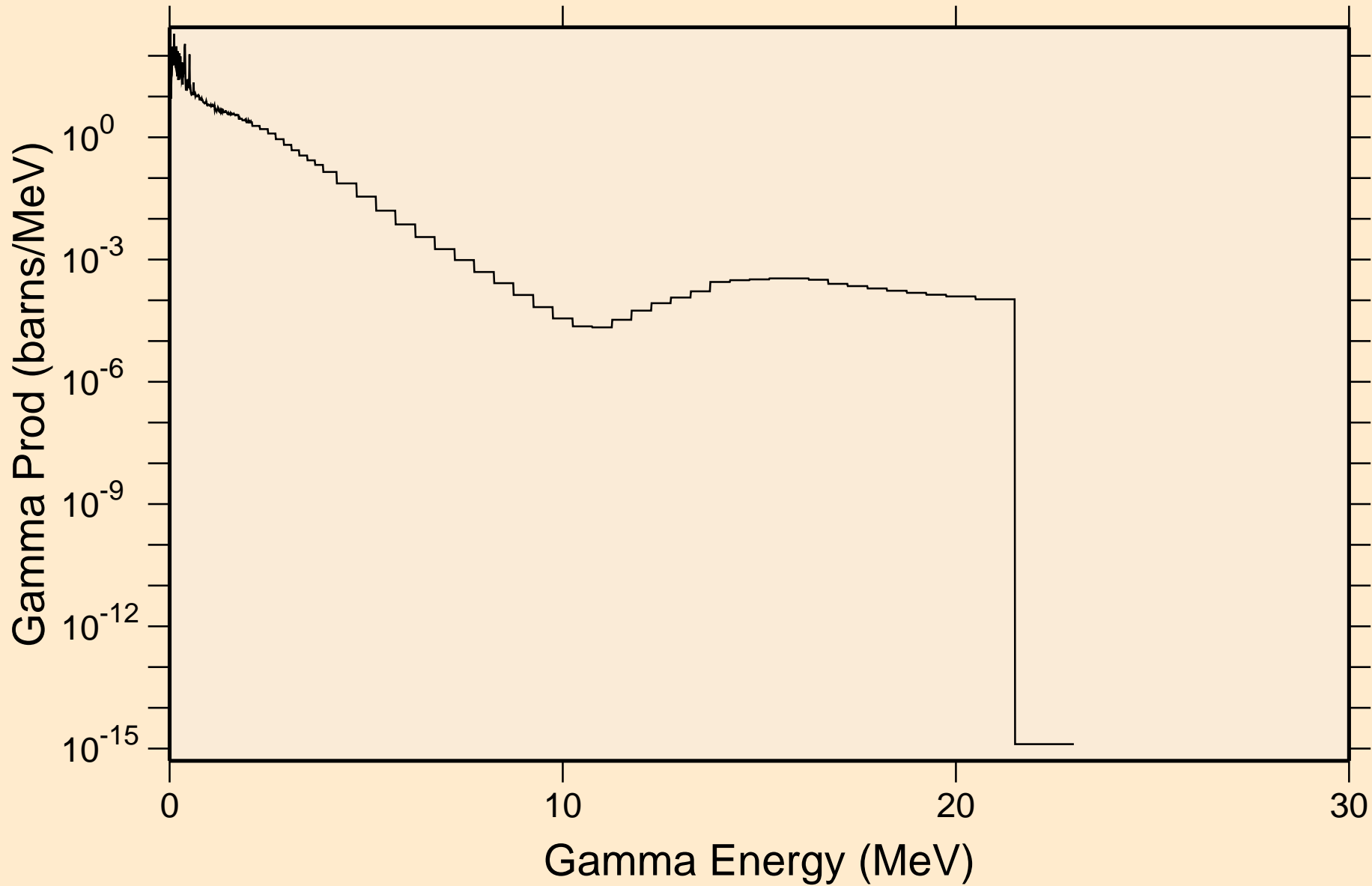

# HF177N NEUTRON ACER TENDL-2024 LIBRARY; T=293.6K

## Particle heating contributions

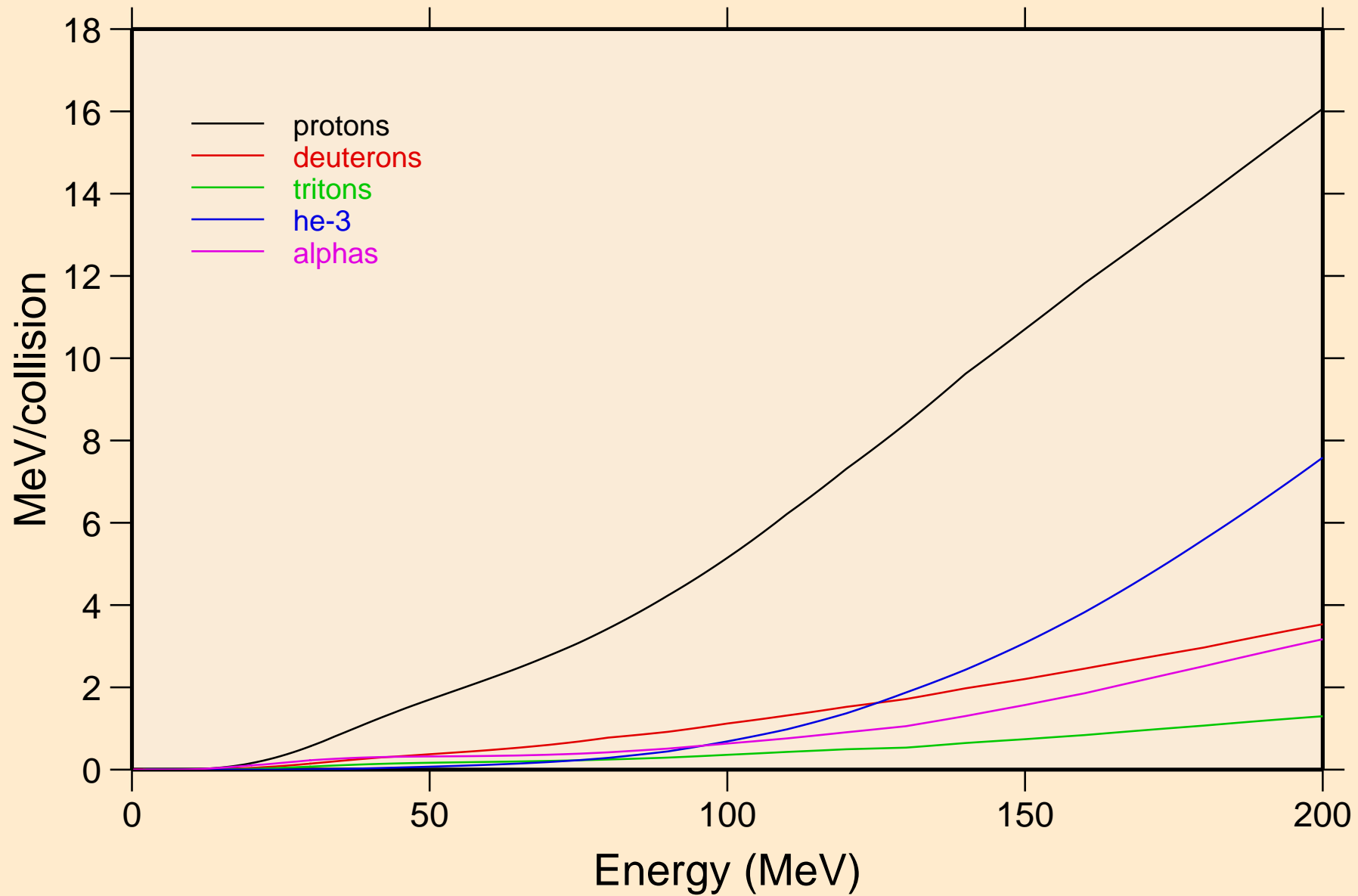

HF177N NEUTRON ACER TENDL-2024 LIBRARY; T=293.6K  
Recoil Heating

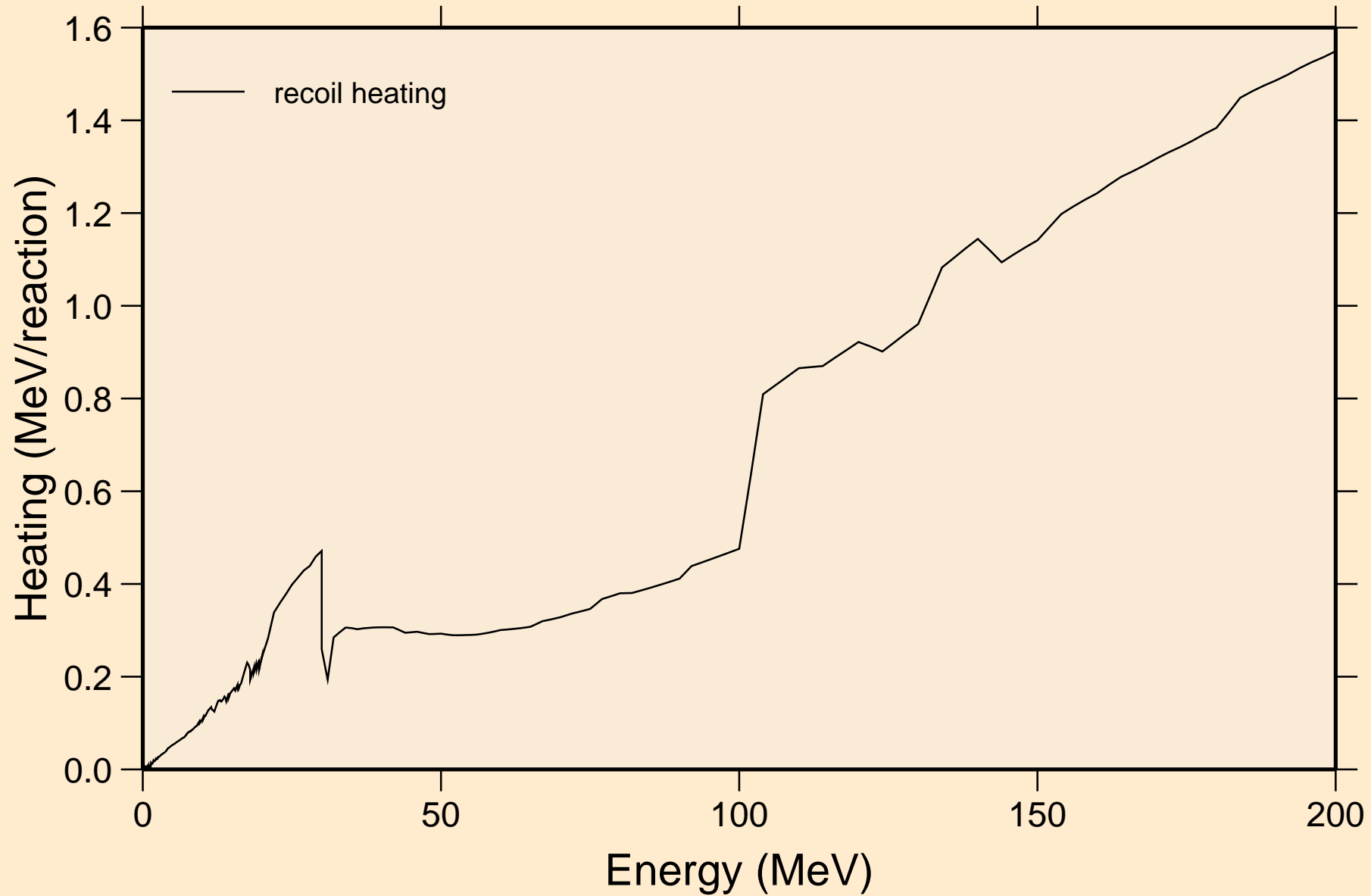

# HF177N NEUTRON ACER TENDL-2024 LIBRARY; T=293.6K

## Particle production cross sections

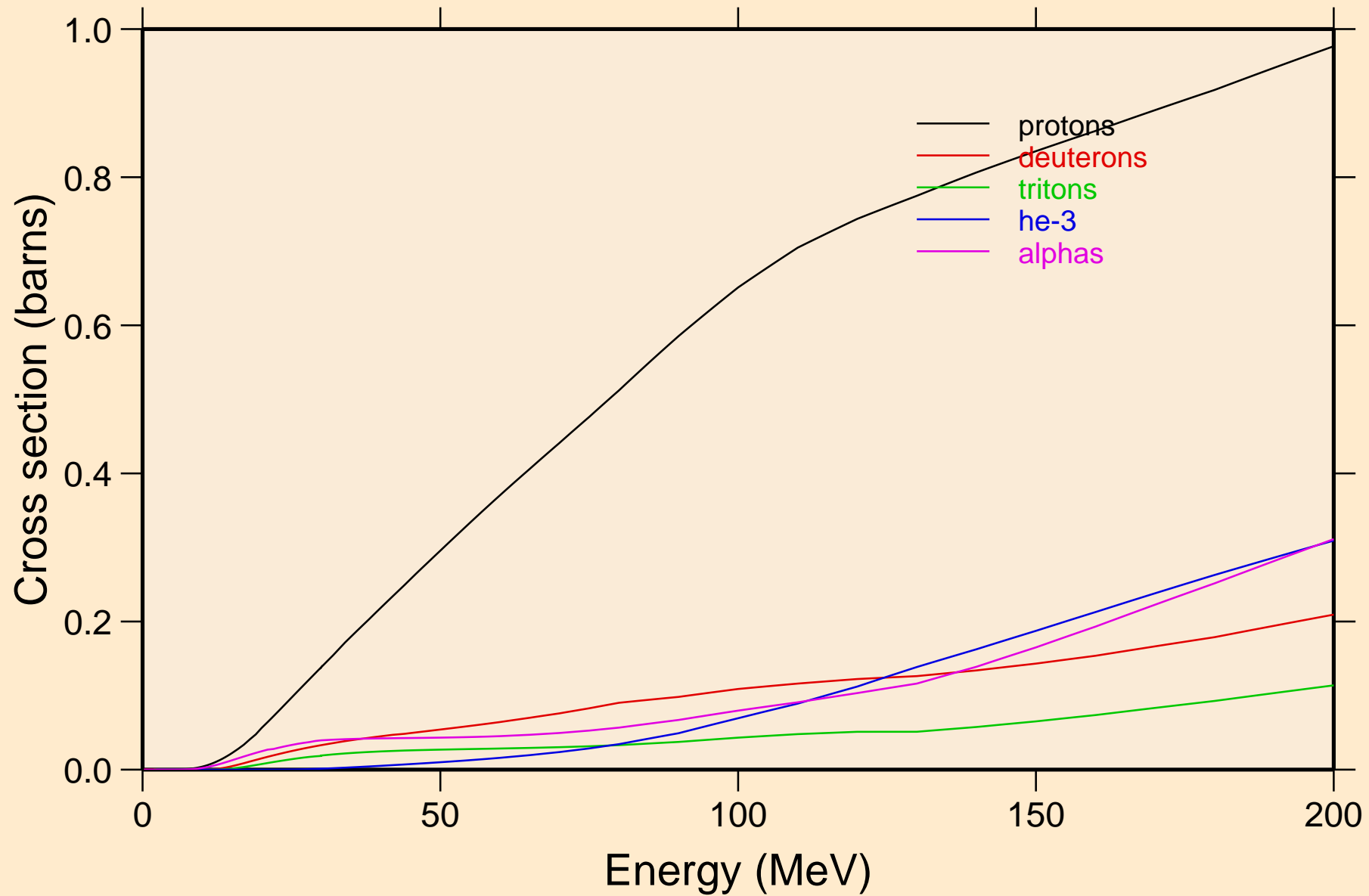

HF177N NEUTRON ACER TENDL-2024 LIBRARY; T=293.6K  
protons from (n,x)

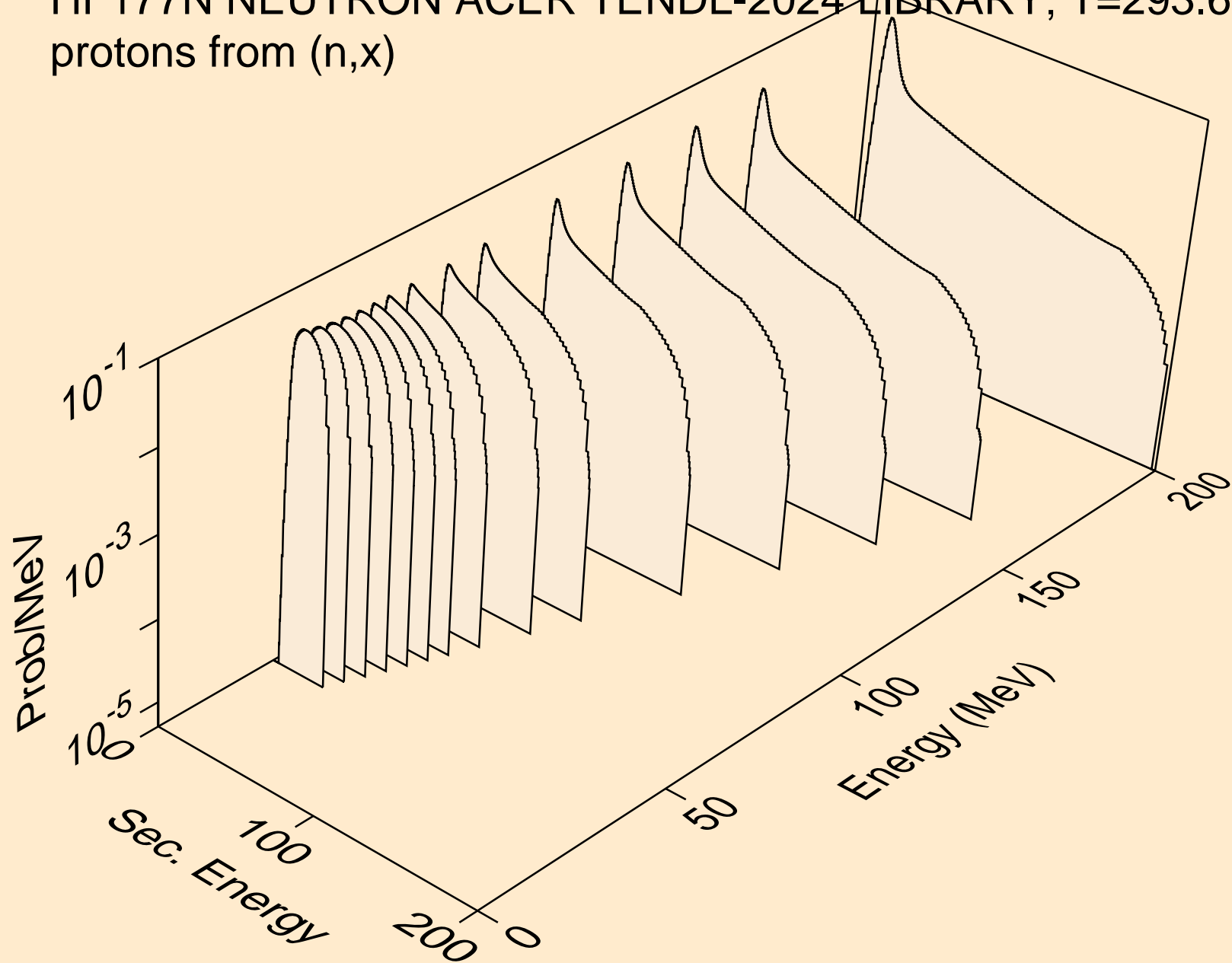

HF177N NEUTRON ACER TENDL-2024 LIBRARY; T=293.6K  
protons from (n,n\*)p

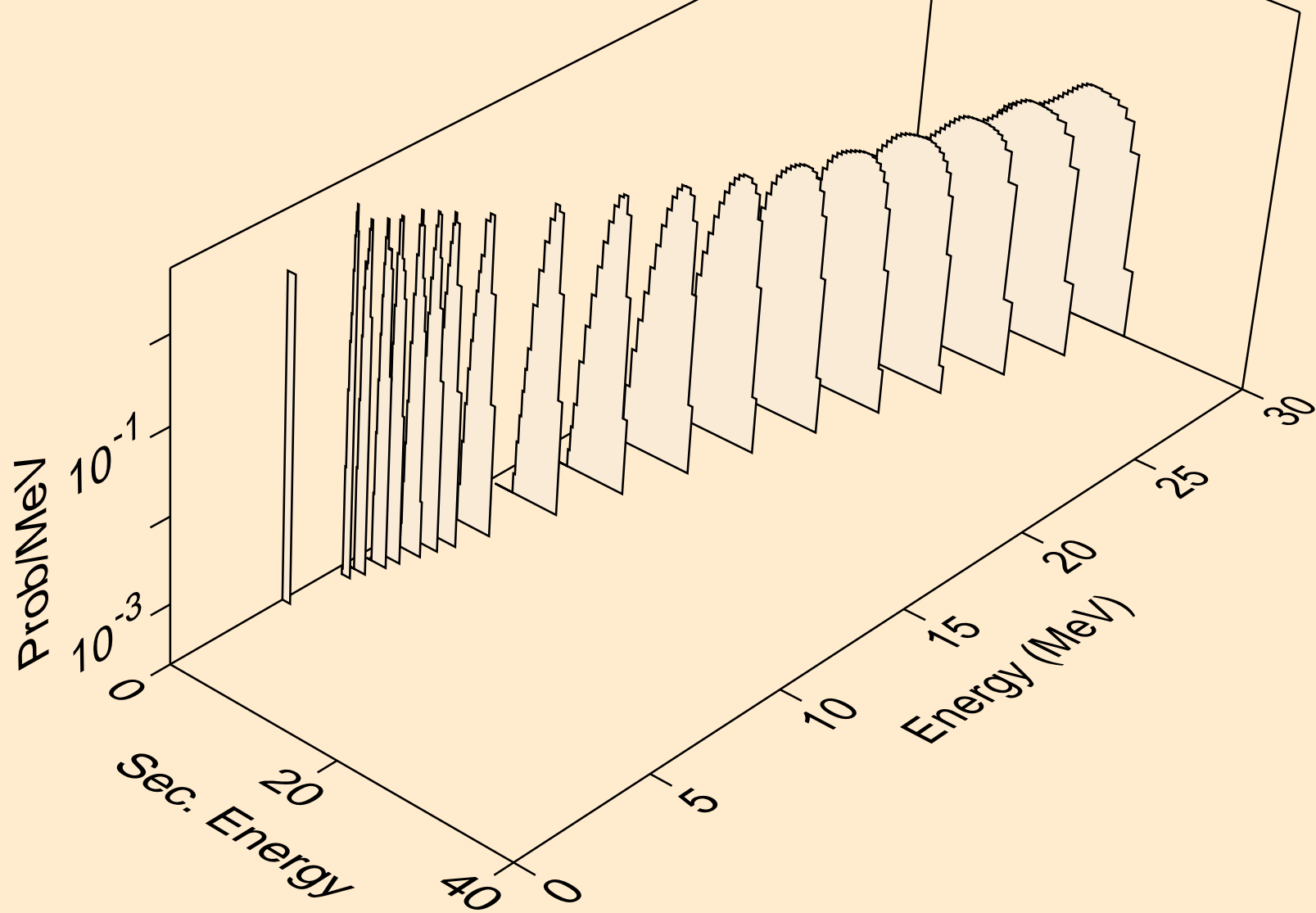

HF177N NEUTRON ACER TENDL-2024 LIBRARY; T=293.6K  
protons from (n,2np)

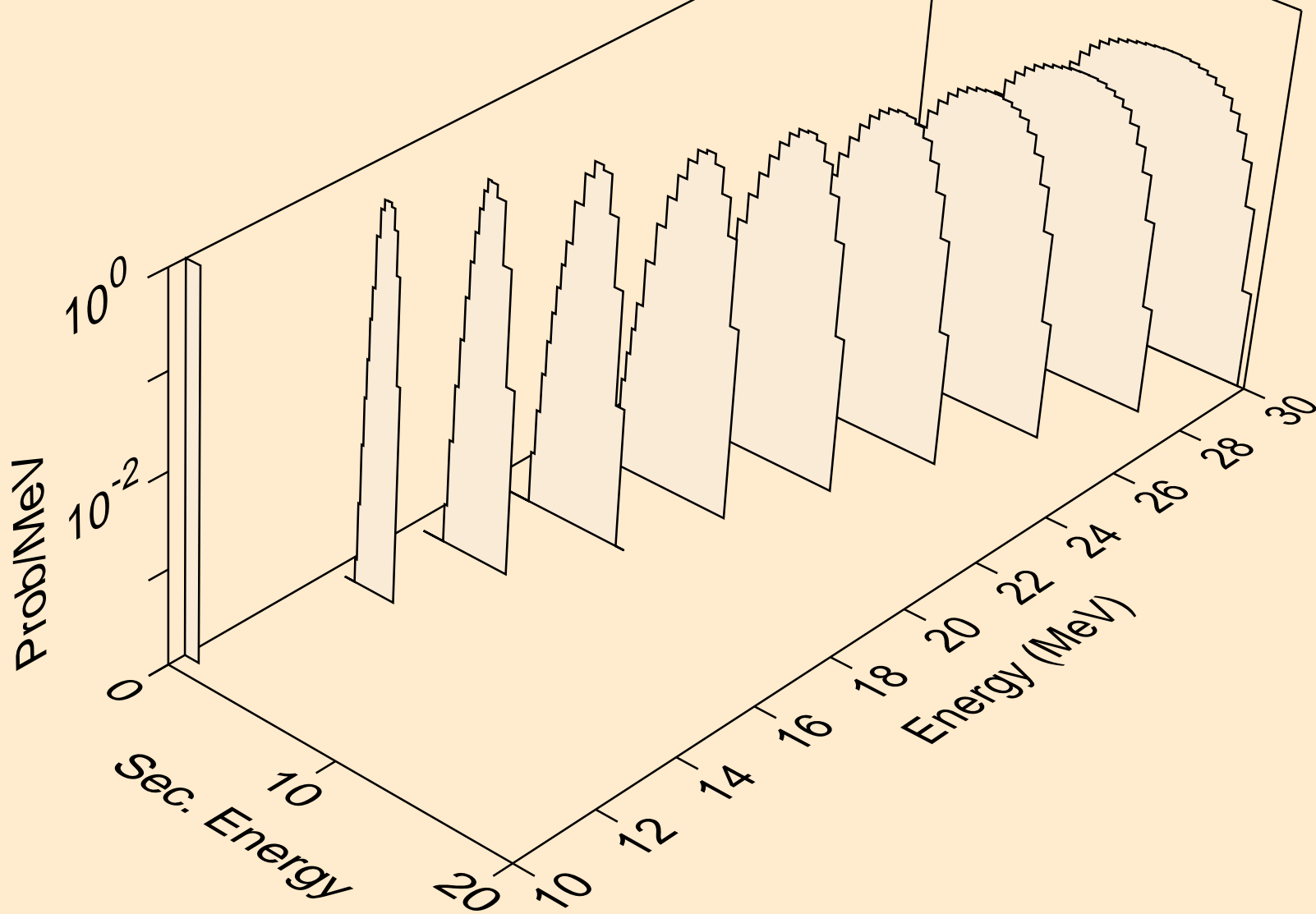

HF177N NEUTRON ACER TENDL-2024 LIBRARY; T=293.6K  
protons from (n,3np)

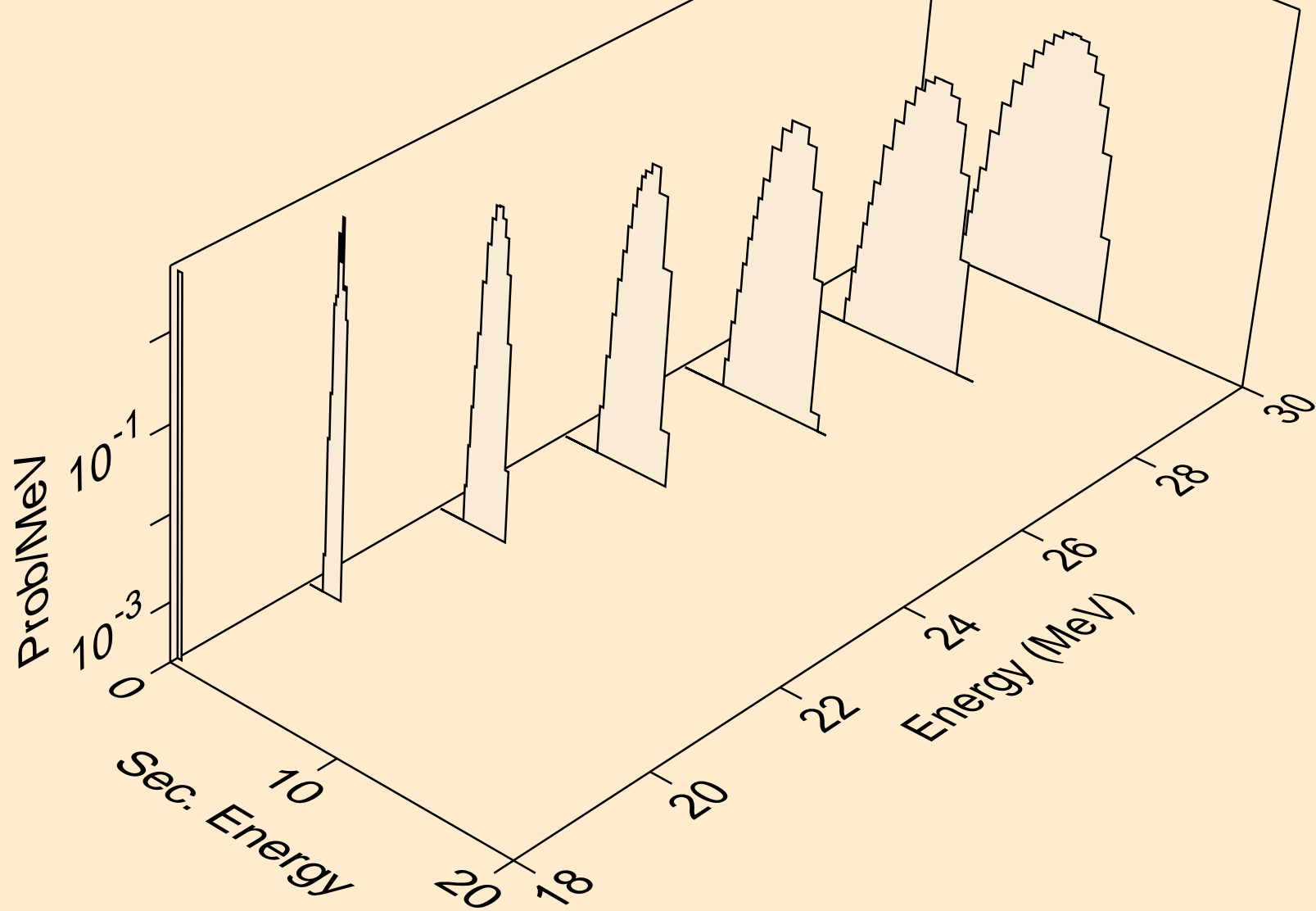

HF177N NEUTRON ACER TENDL-2024 LIBRARY; T=293.6K  
protons from (n,n2p)

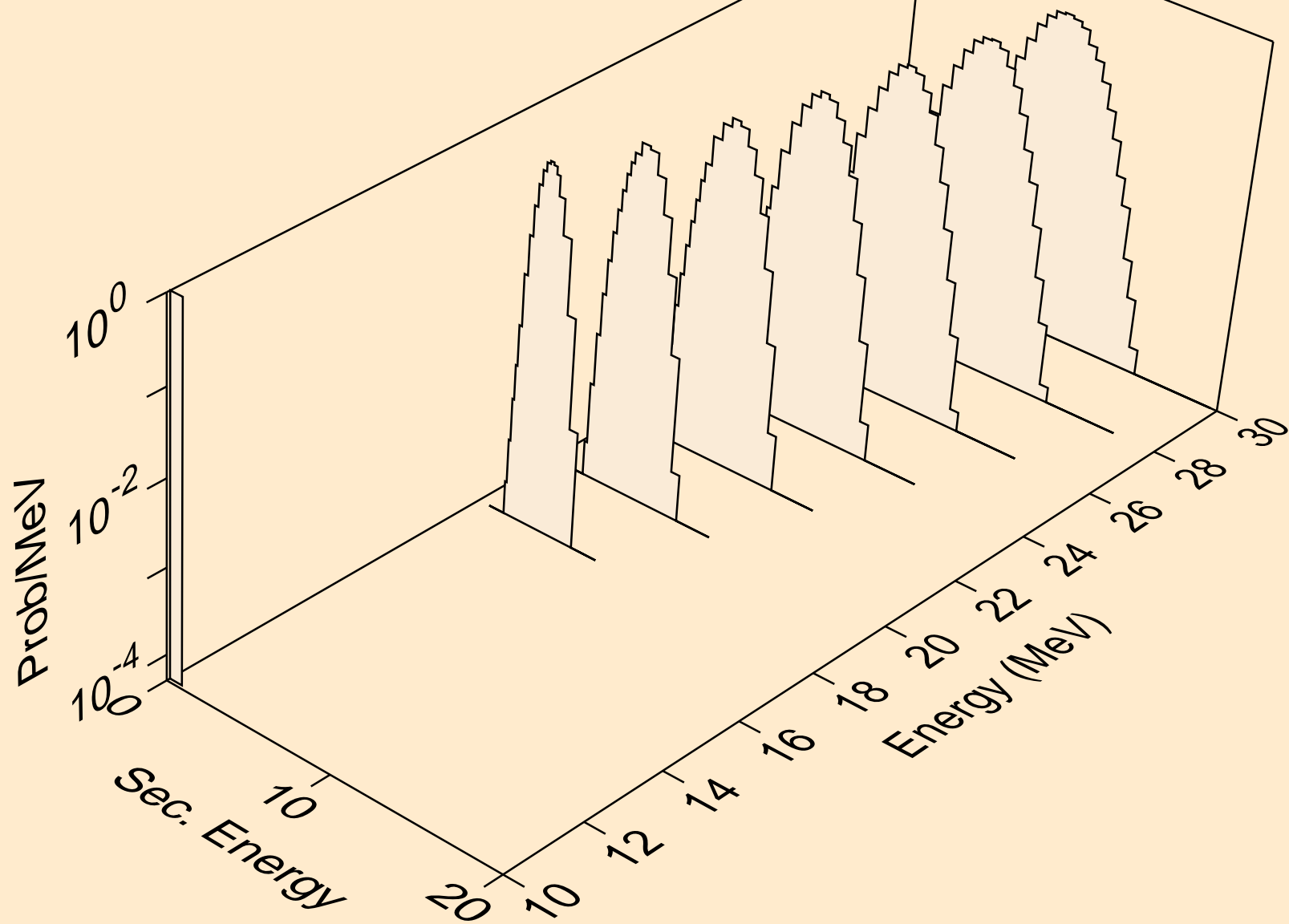

HF177N NEUTRON ACER TENDL-2024 LIBRARY; T=293.6K  
protons from (n,npa)

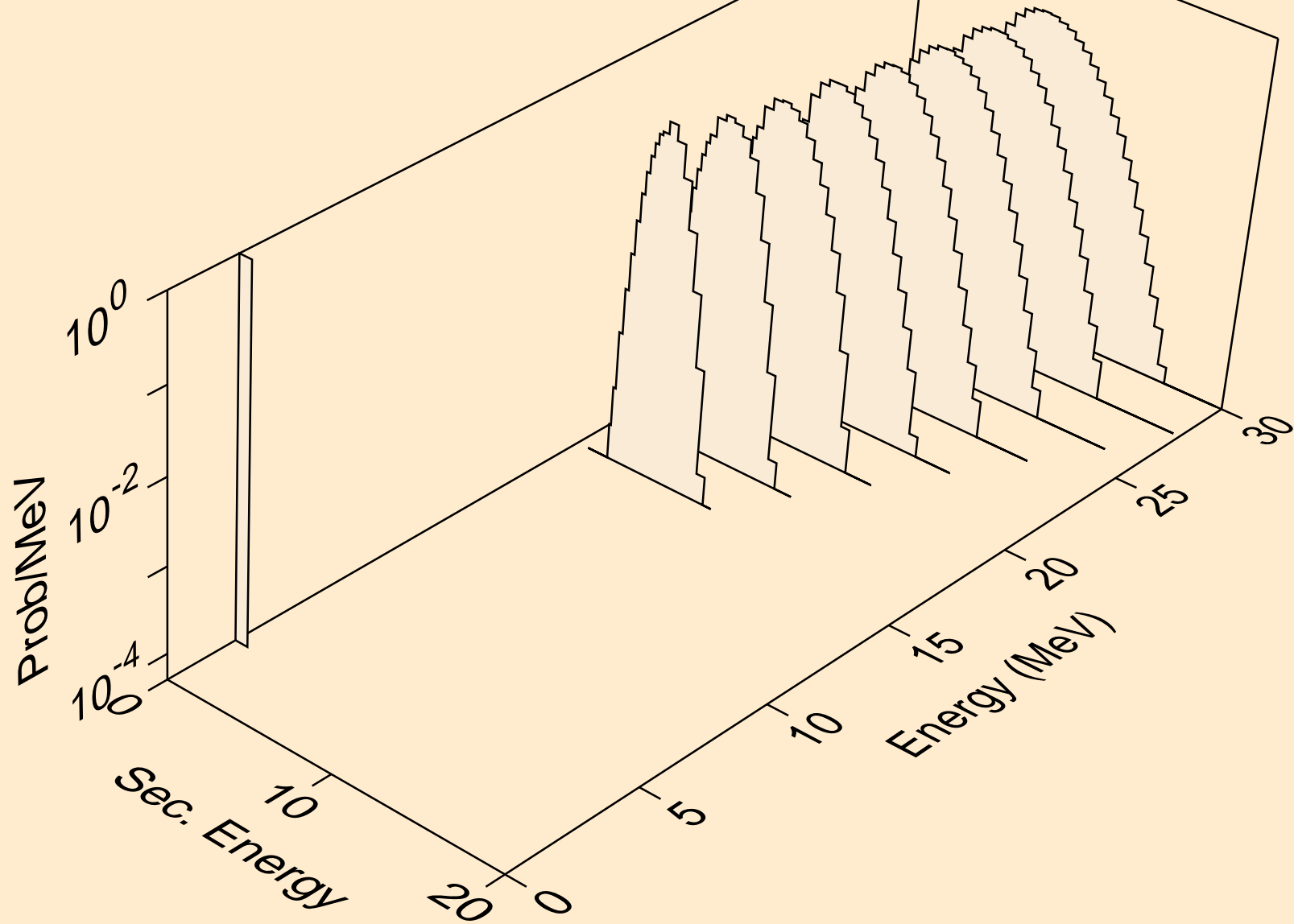

HF177N NEUTRON ACER TENDL-2024 LIBRARY; T=293.6K  
protons from (n,p)

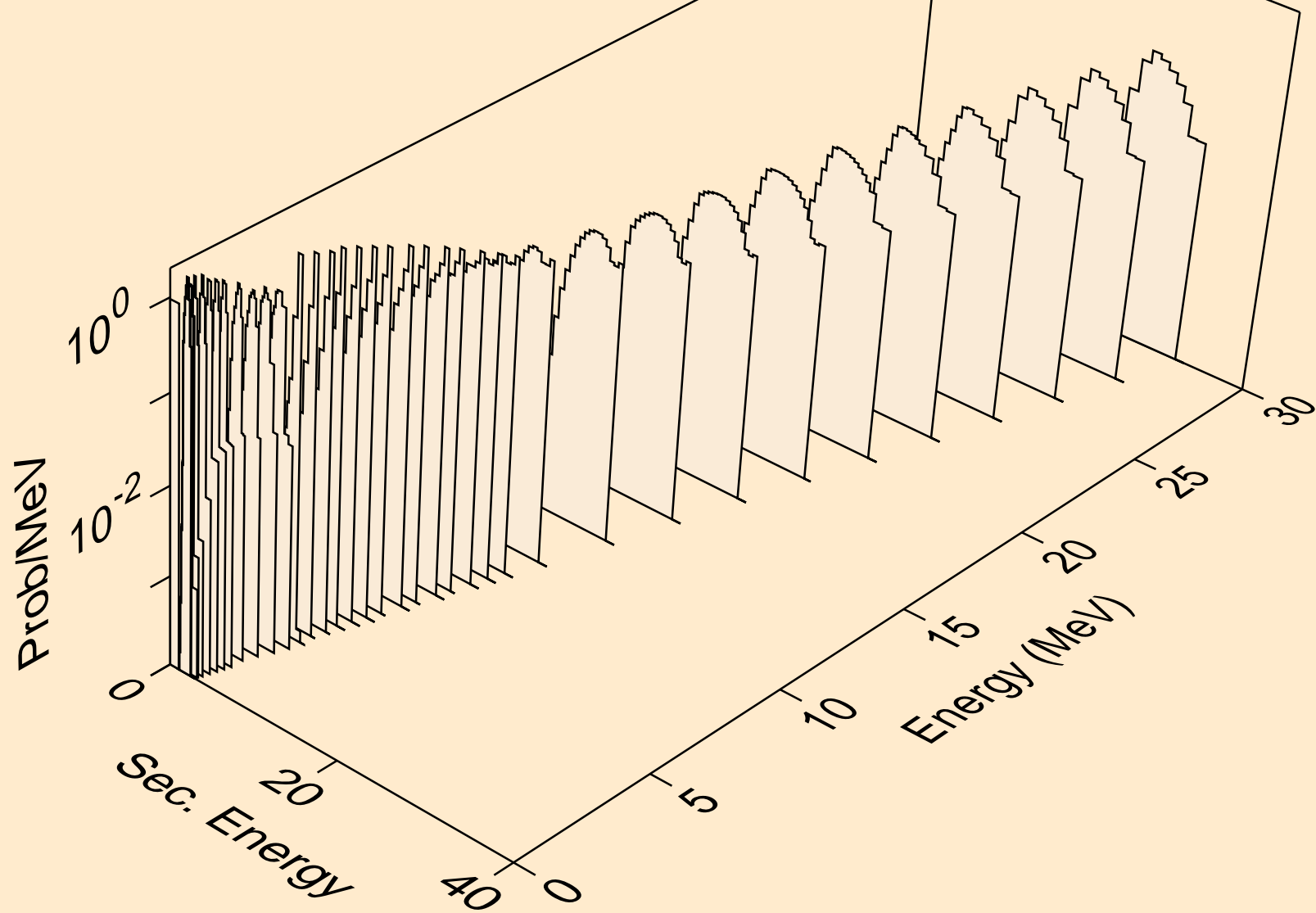

HF177N NEUTRON ACER TENDL-2024 LIBRARY; T=293.6K  
protons from (n,2p)

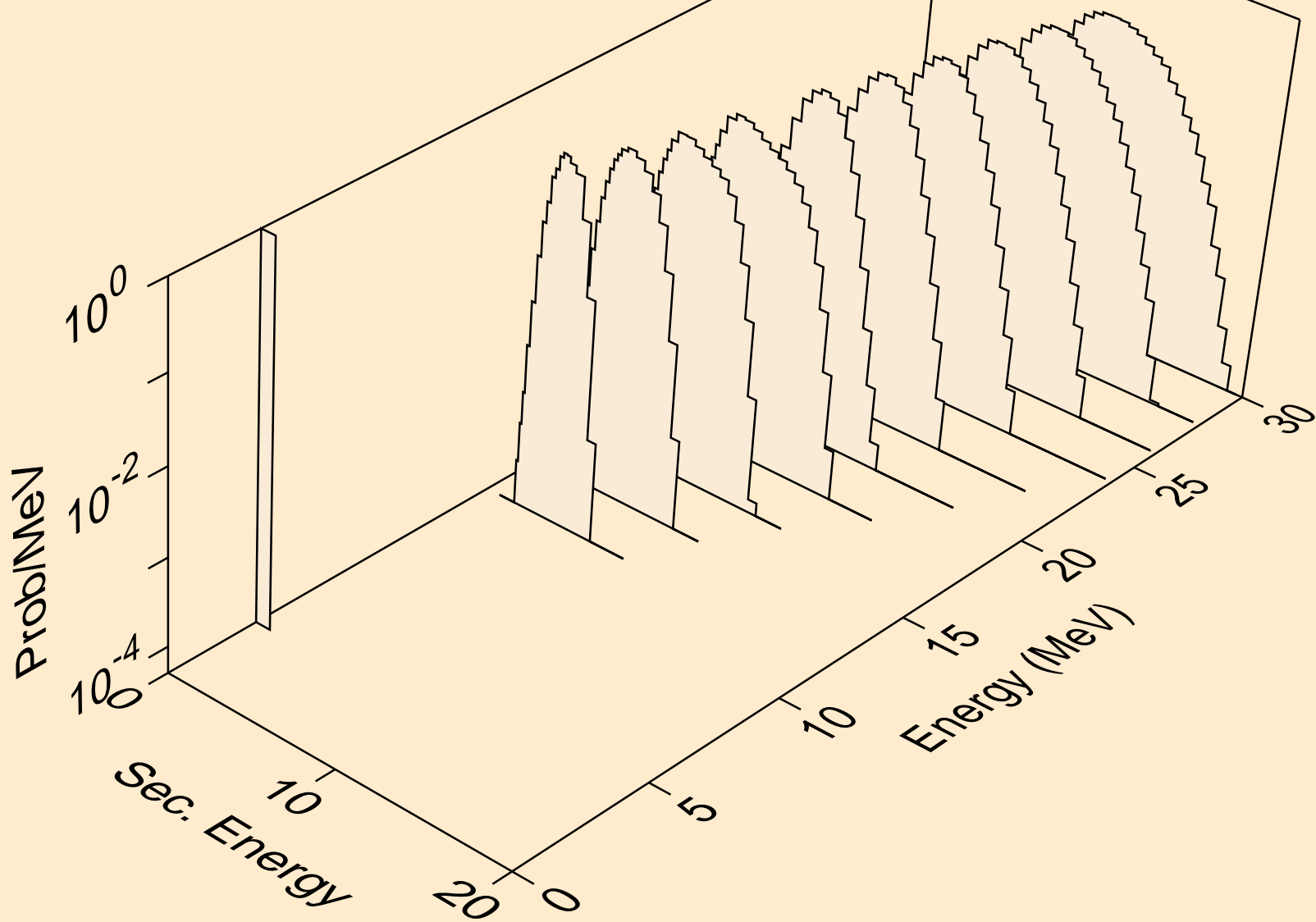

HF177N NEUTRON ACER TENDL-2024 LIBRARY; T=293.6K  
protons from (n,p)

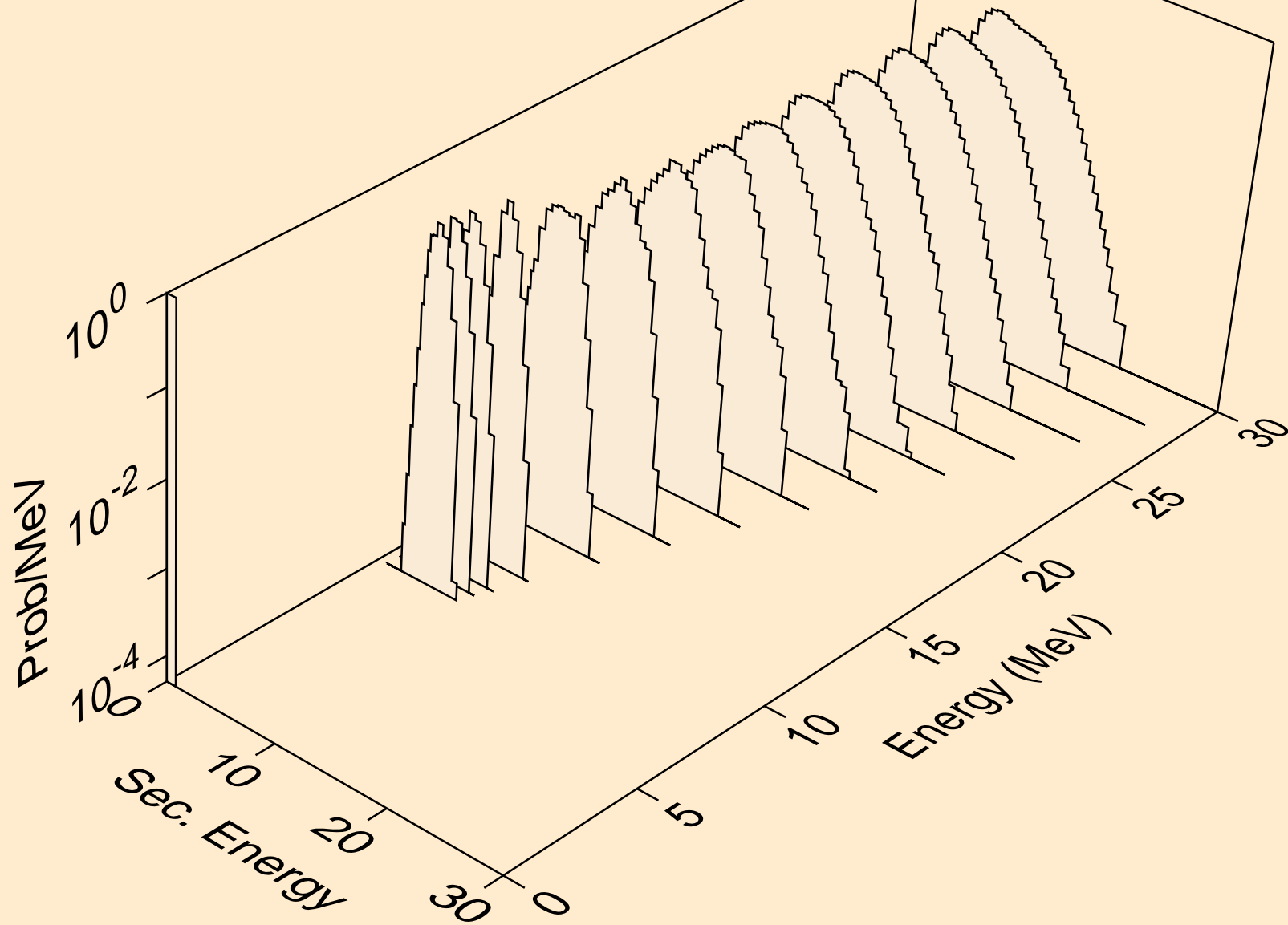

HF177N NEUTRON ACER TENDL-2024 LIBRARY; T=293.6K  
protons from (n,pd)

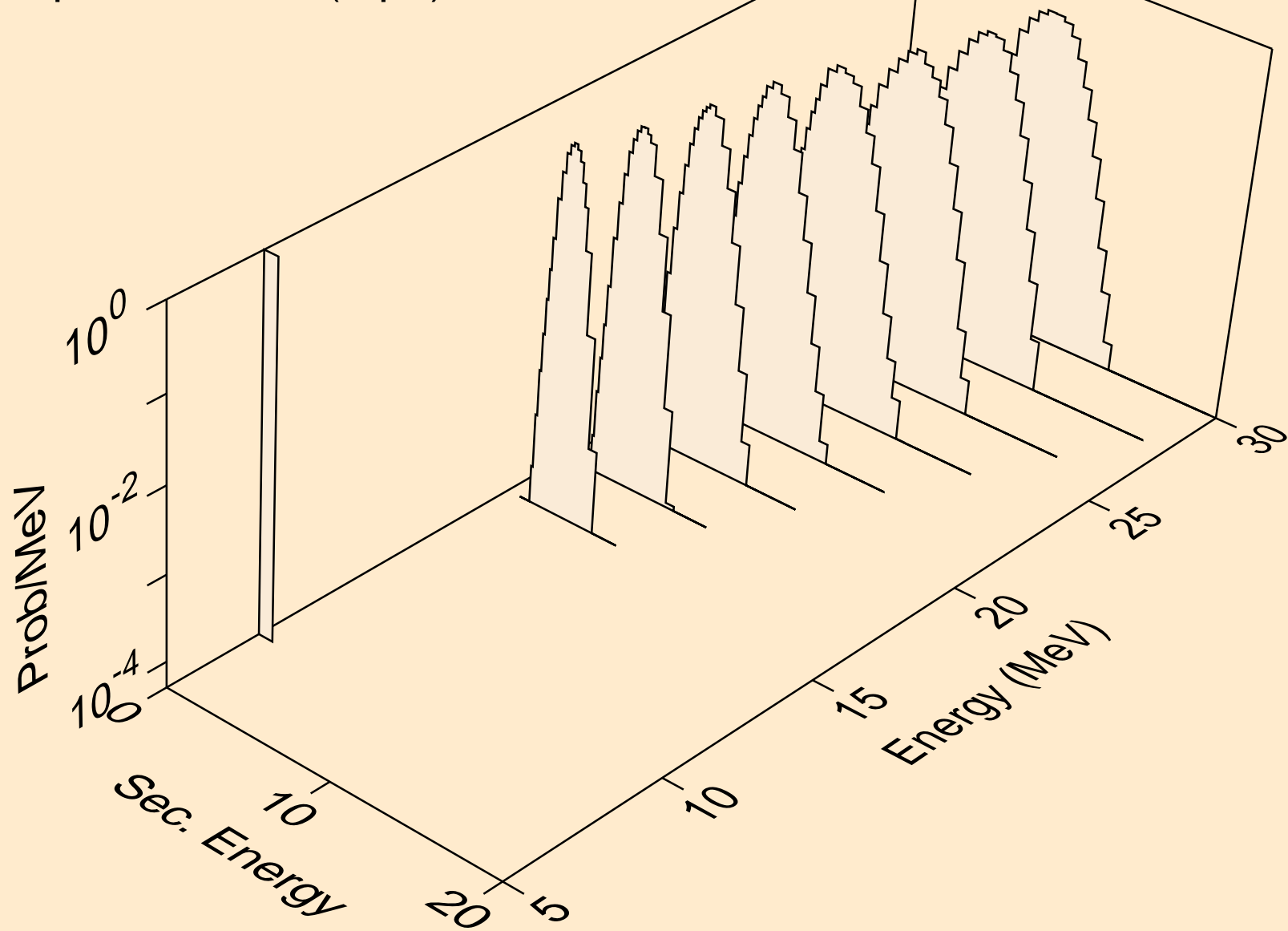

HF177N NEUTRON ACER TENDL-2024 LIBRARY; T=293.6K  
protons from (n,pt)

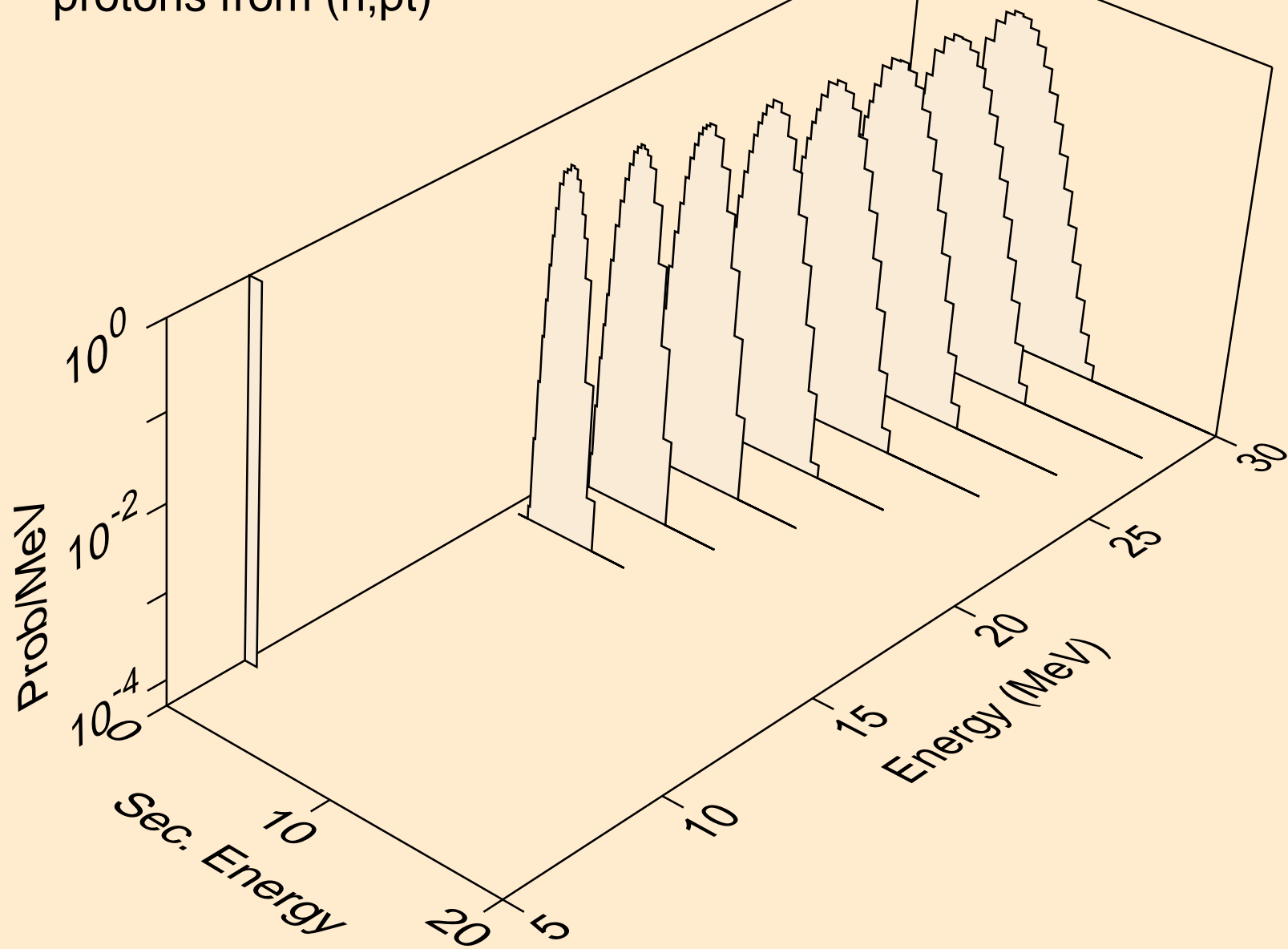

HF177N NEUTRON ACER TENDL-2024 LIBRARY; T=293.6K  
deuterons from (n,x)

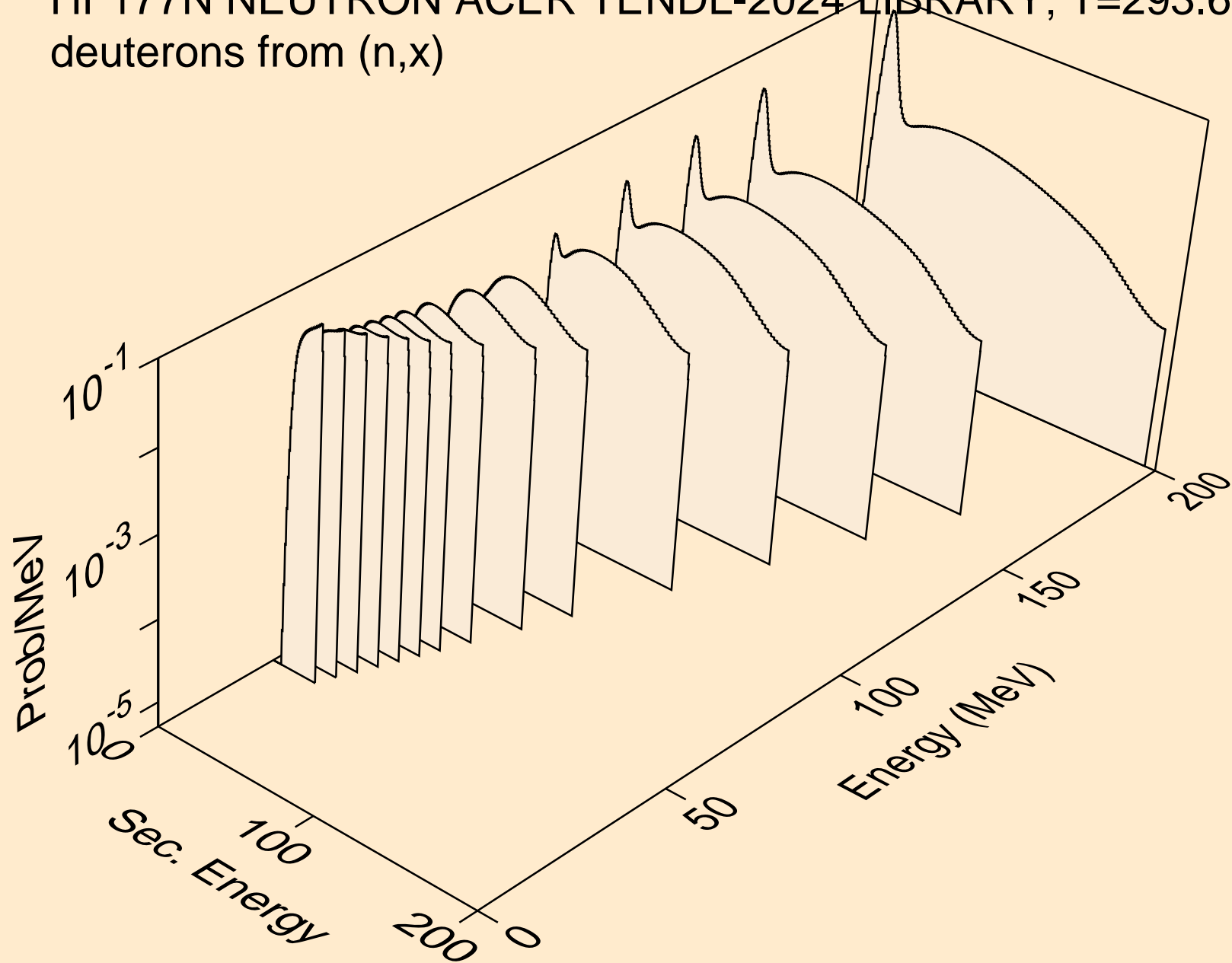

HF177N NEUTRON ACER TENDL-2024 LIBRARY; T=293.6K  
deuterons from (n,2nd)

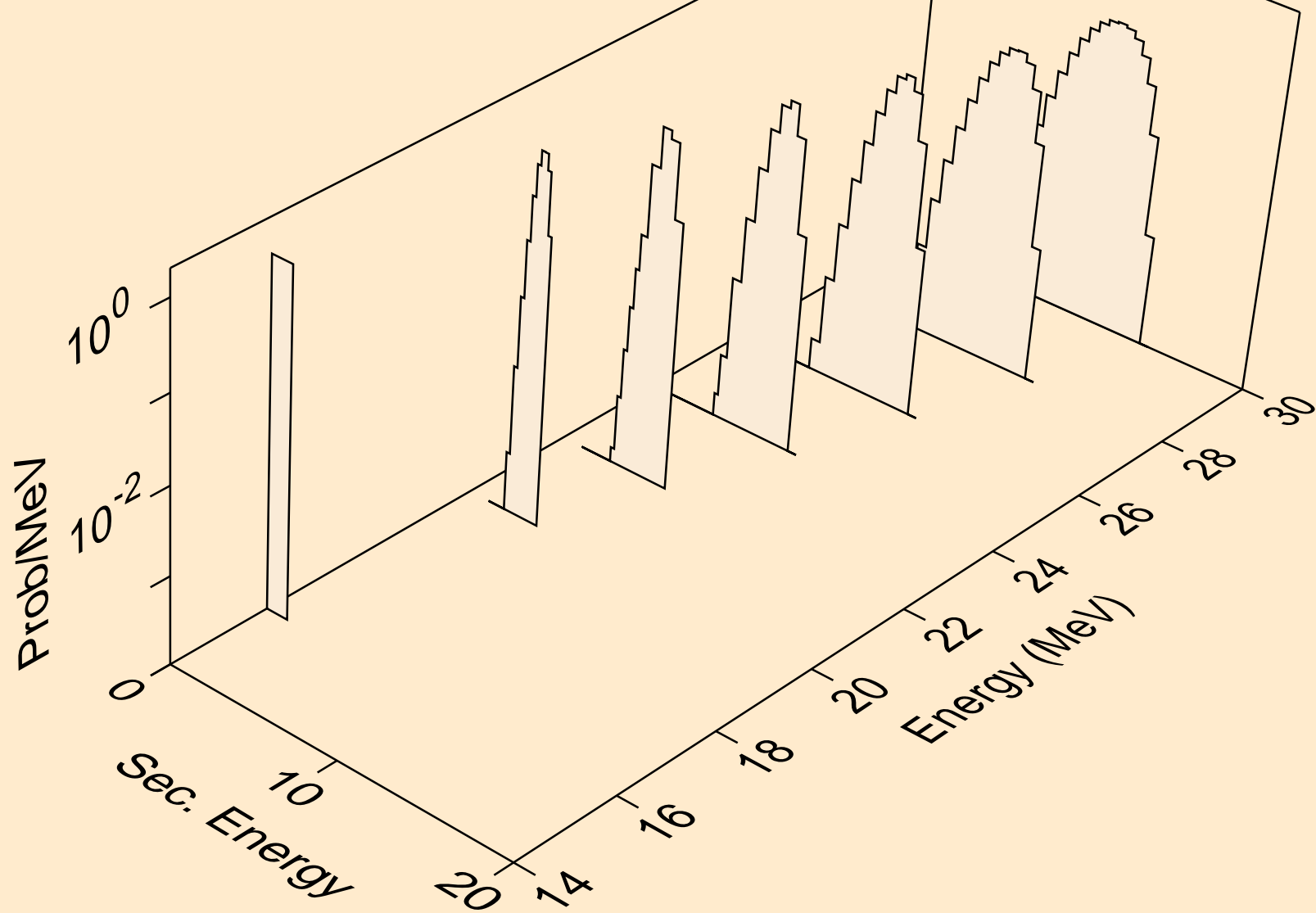

HF177N NEUTRON ACER TENDL-2024 LIBRARY; T=293.6K  
deuterons from (n,n\*)d

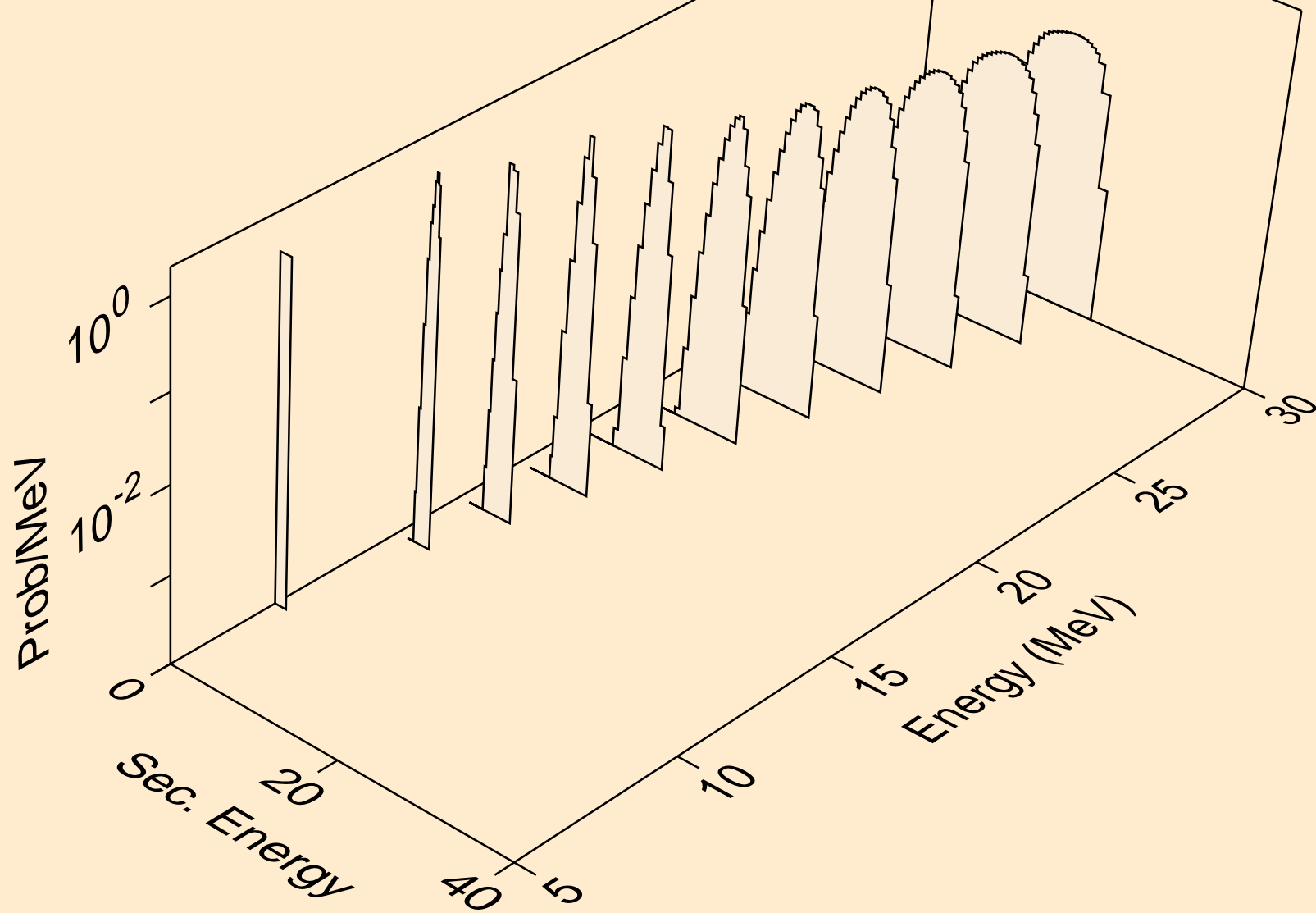

HF177N NEUTRON ACER TENDL-2024 LIBRARY; T=293.6K  
deuterons from (n,d)

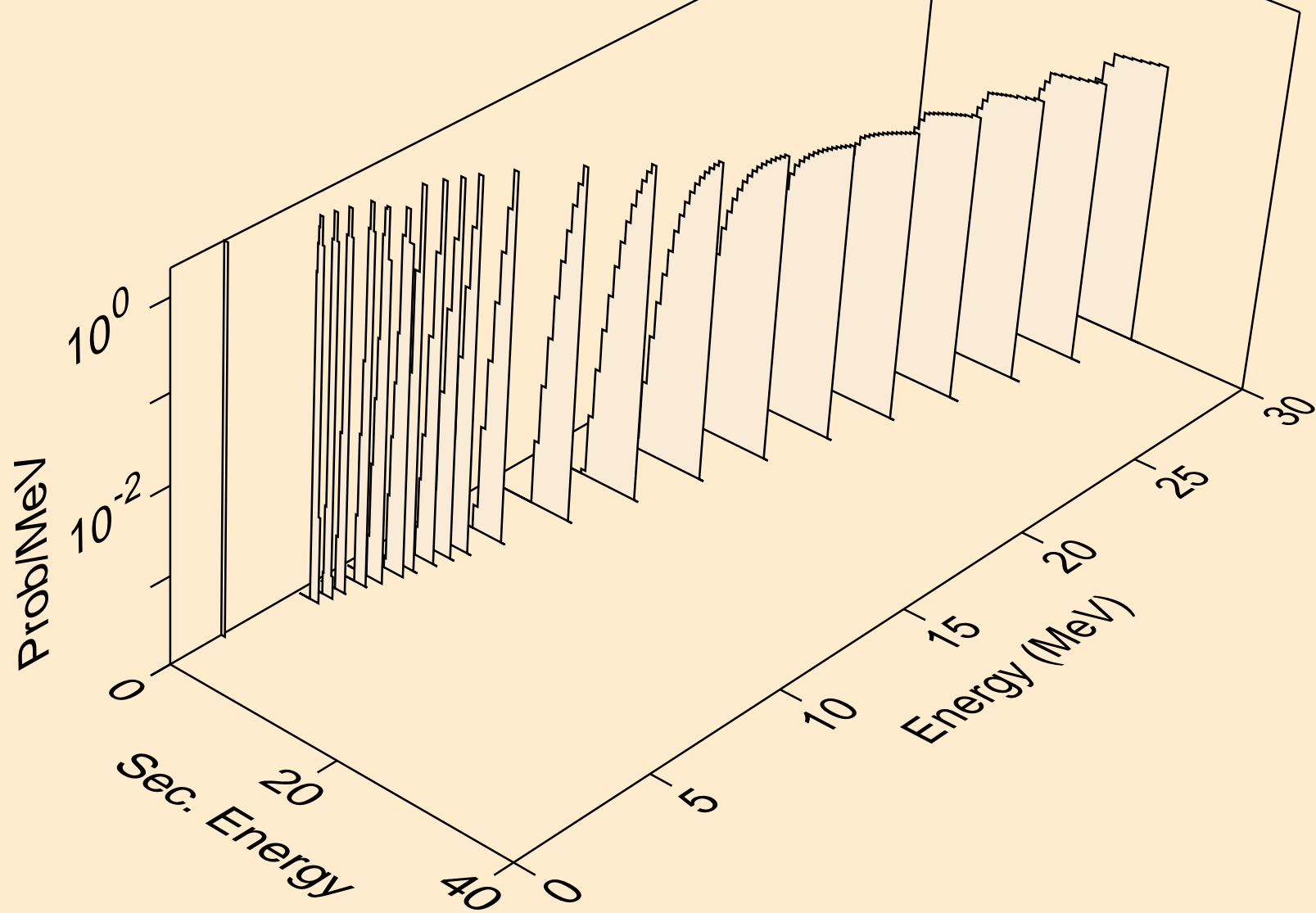

HF177N NEUTRON ACER TENDL-2024 LIBRARY; T=293.6K  
deuterons from (n,pd)

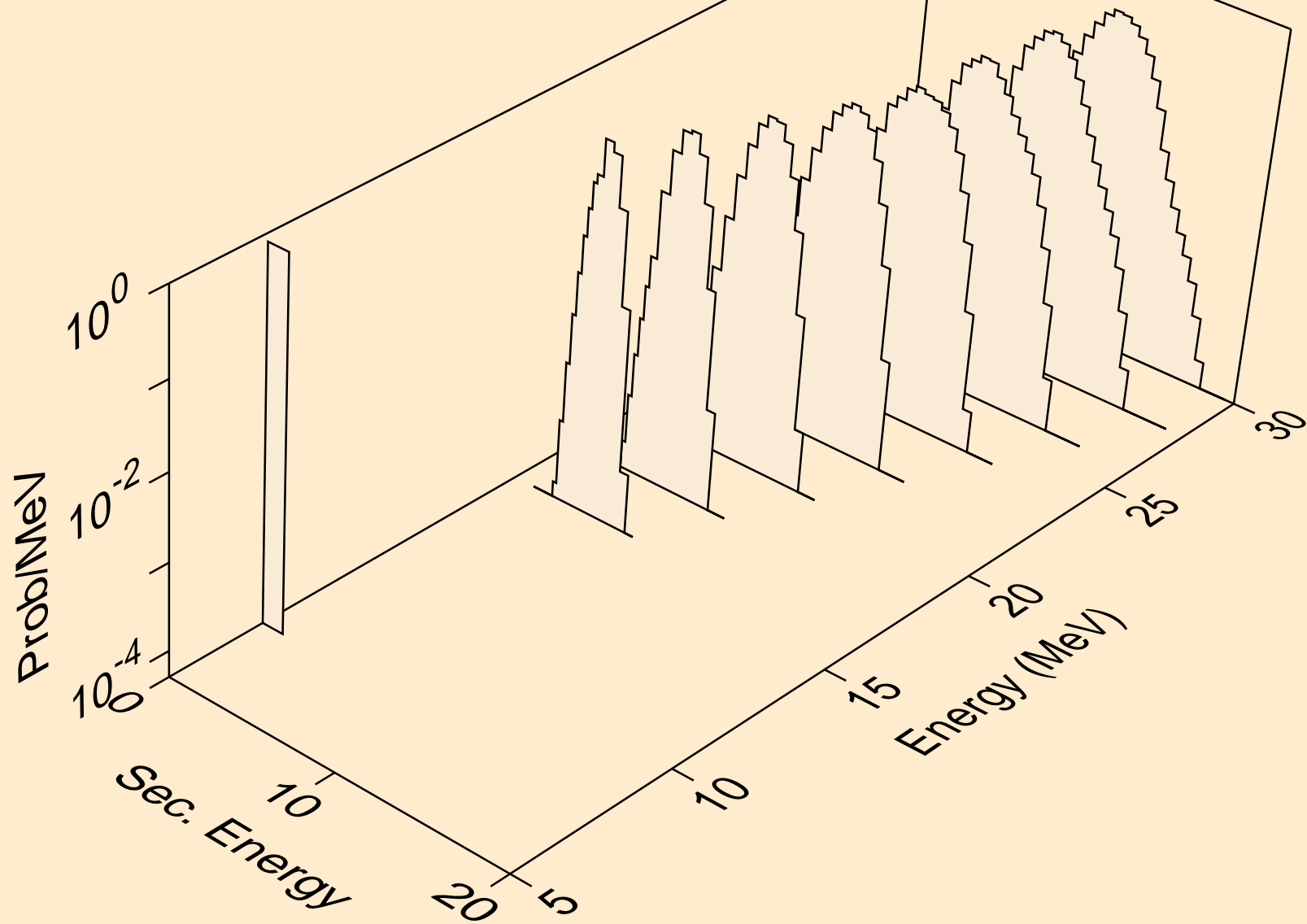

HF177N NEUTRON ACER TENDL-2024 LIBRARY; T=293.6K  
deuterons from (n,da)

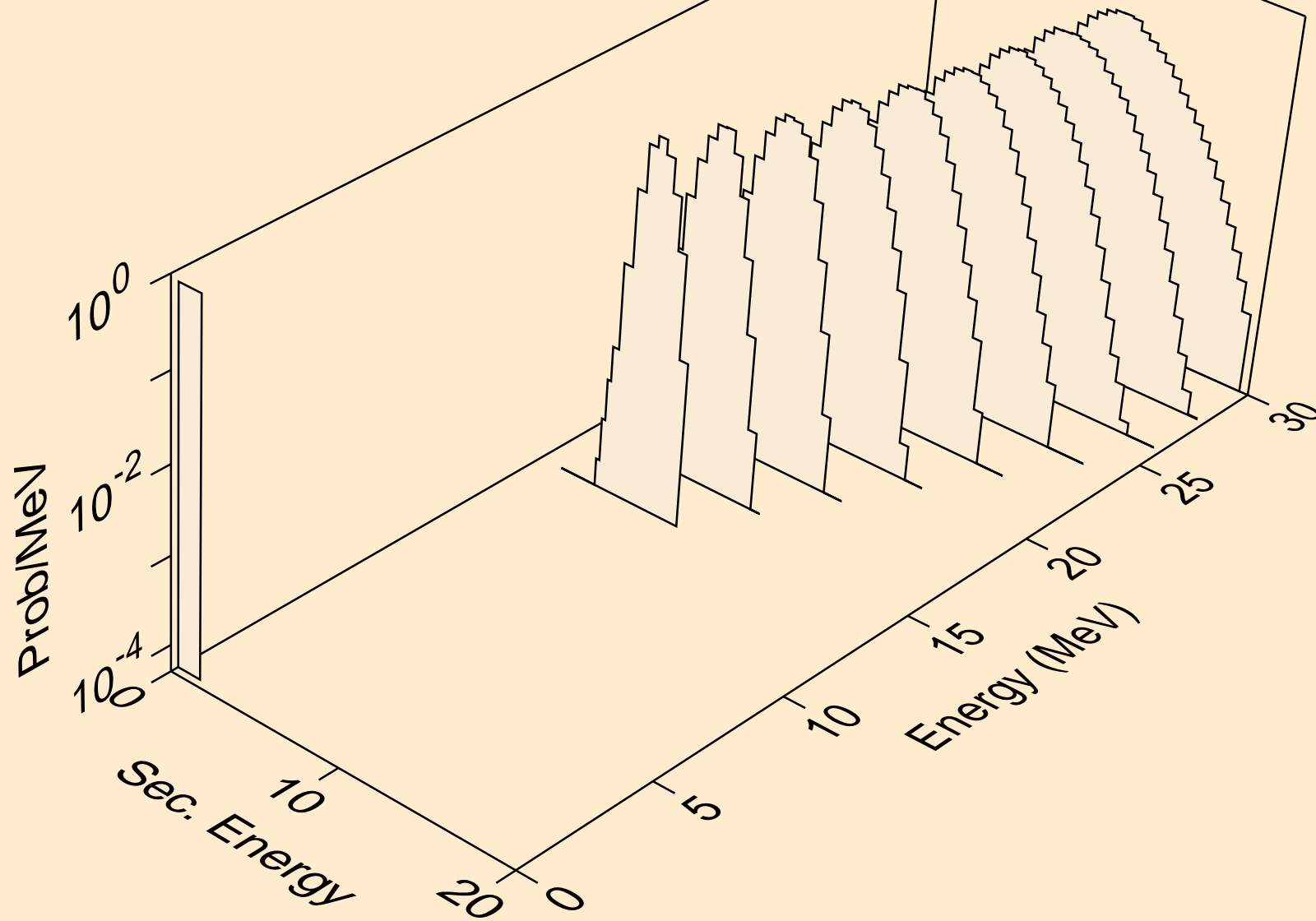

HF177N NEUTRON ACER TENDL-2024 LIBRARY; T=293.6K  
tritons from (n,x)

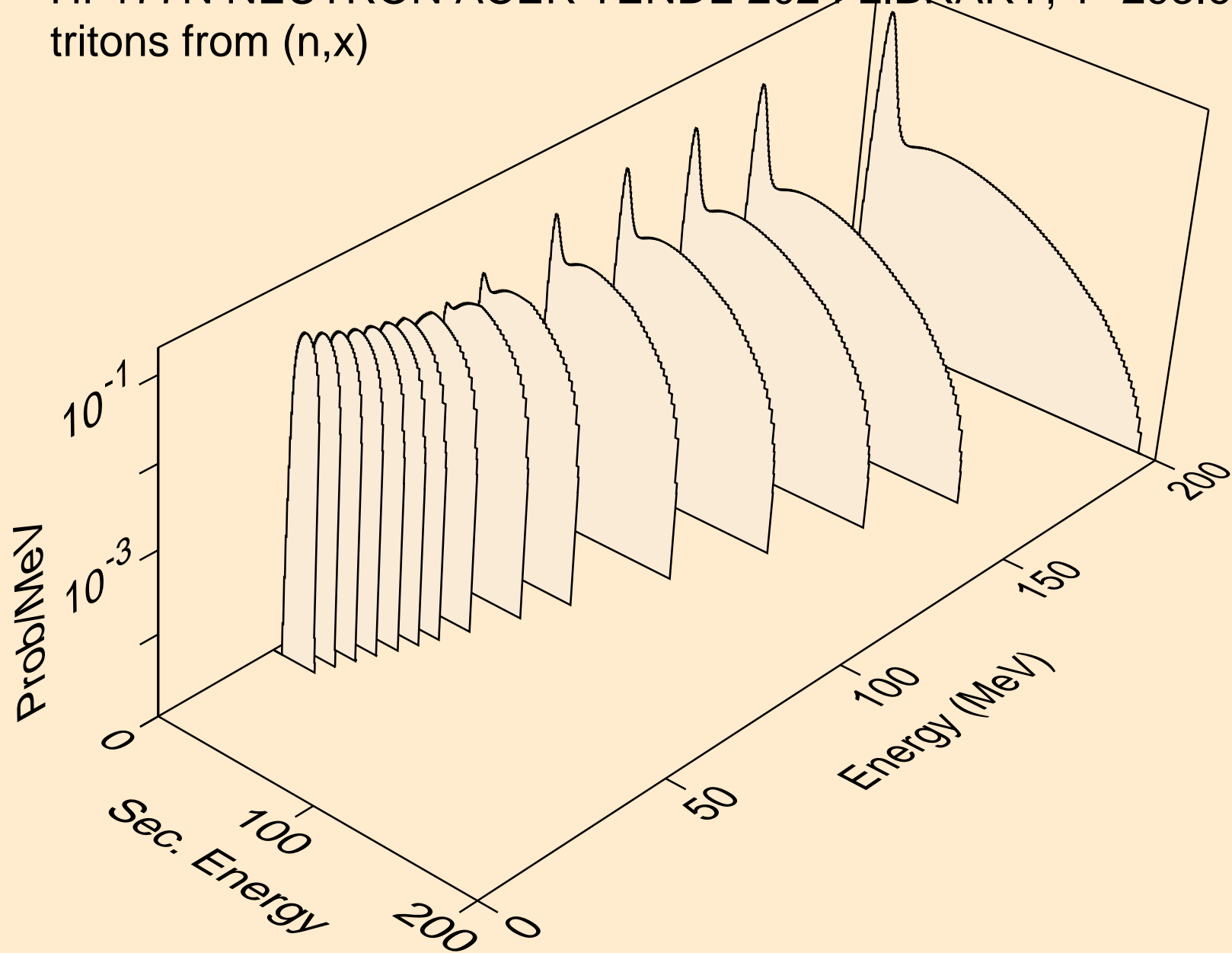

HF177N NEUTRON ACER TENDL-2024 LIBRARY; T=293.6K  
tritons from (n,n\*)t

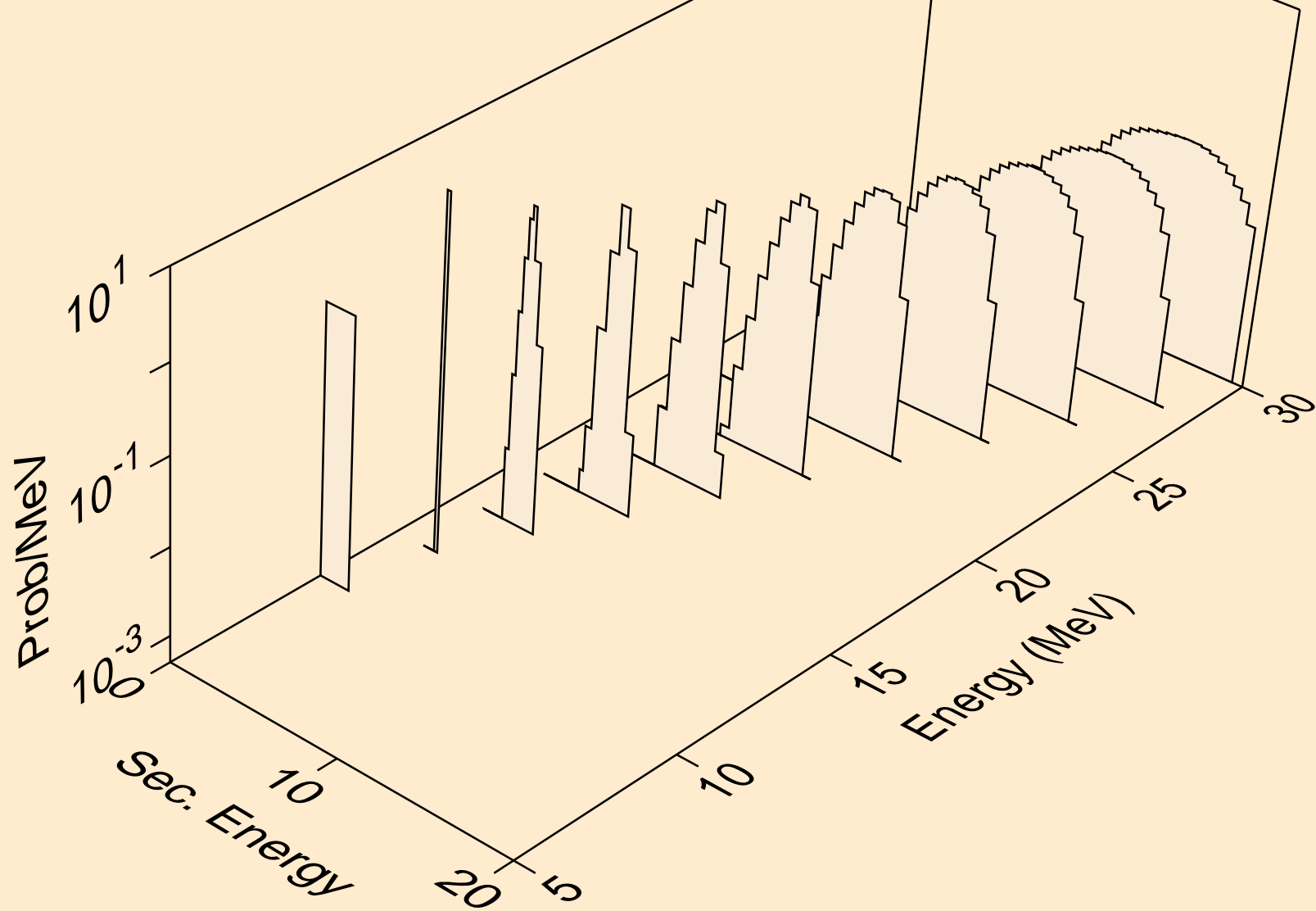

HF177N NEUTRON ACER TENDL-2024 LIBRARY; T=293.6K  
tritons from (n,t)

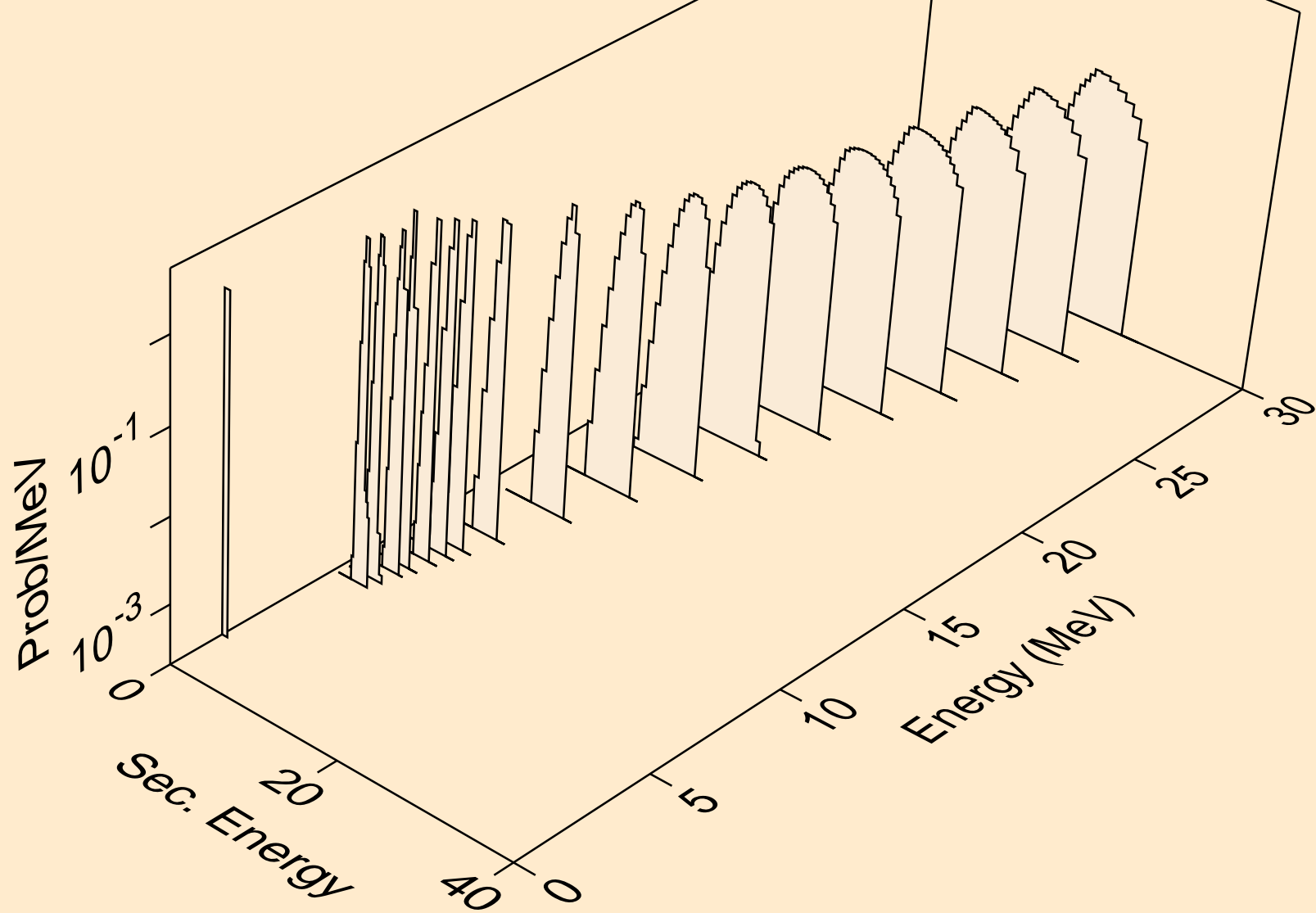

HF177N NEUTRON ACER TENDL-2024 LIBRARY; T=293.6K  
tritons from (n,pt)

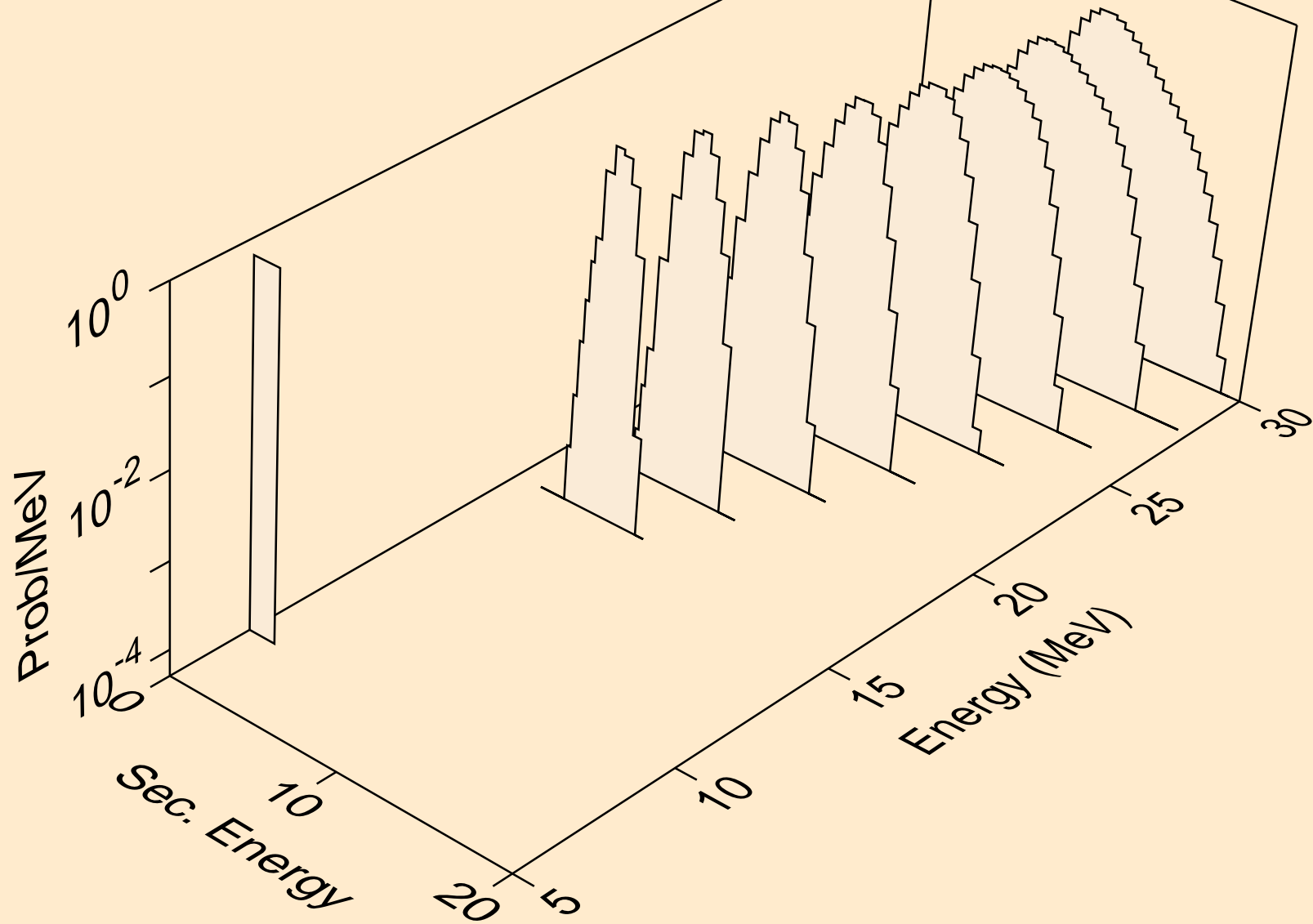

HF177N NEUTRON ACER TENDL-2024 LIBRARY; T=293.6K  
he3s from (n,x)

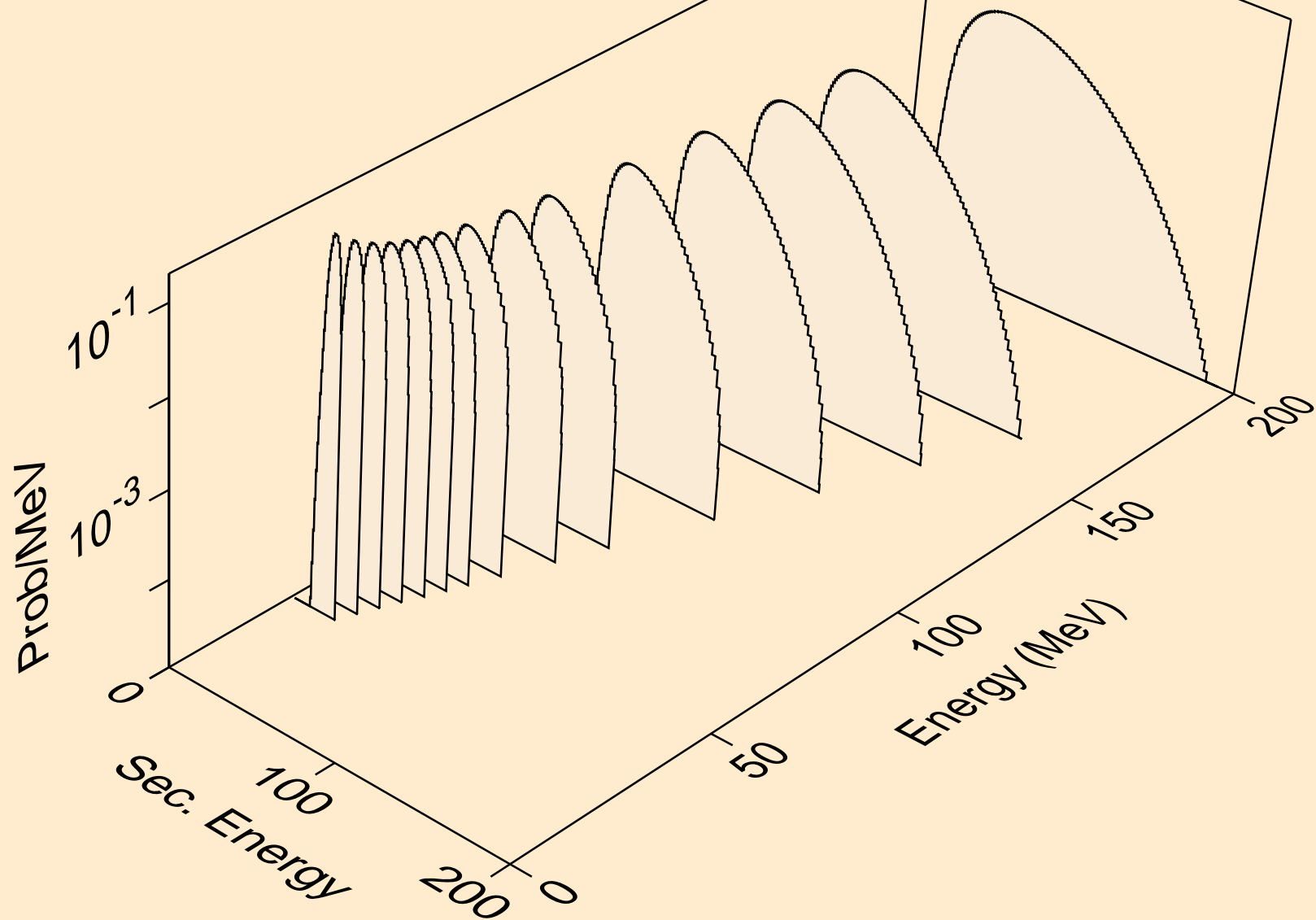

HF177N NEUTRON ACER TENDL-2024 LIBRARY; T=293.6K  
he3s from (n,n\*)he3

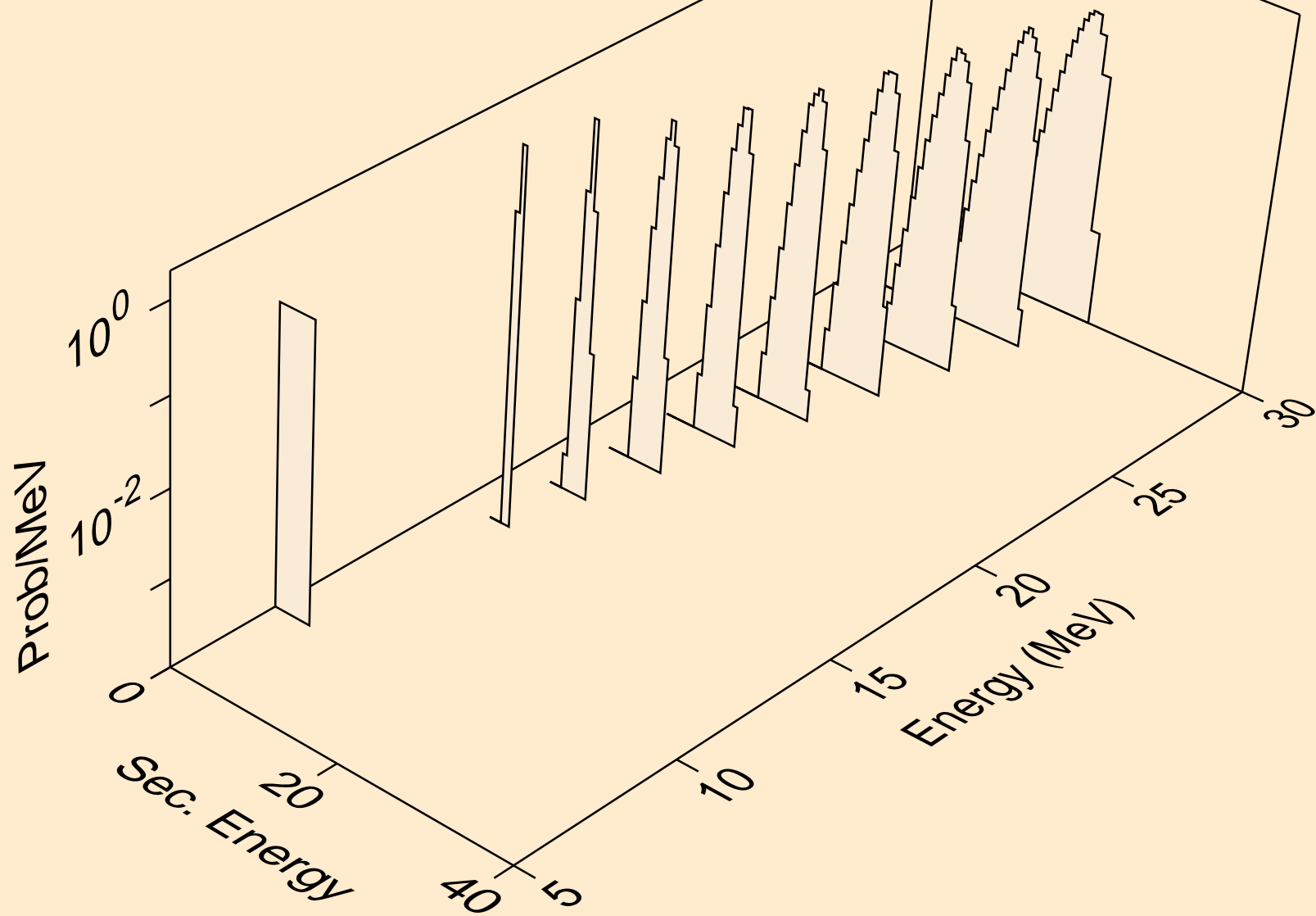

HF177N NEUTRON ACER TENDL-2024 LIBRARY; T=293.6K  
he3s from (n,he3)

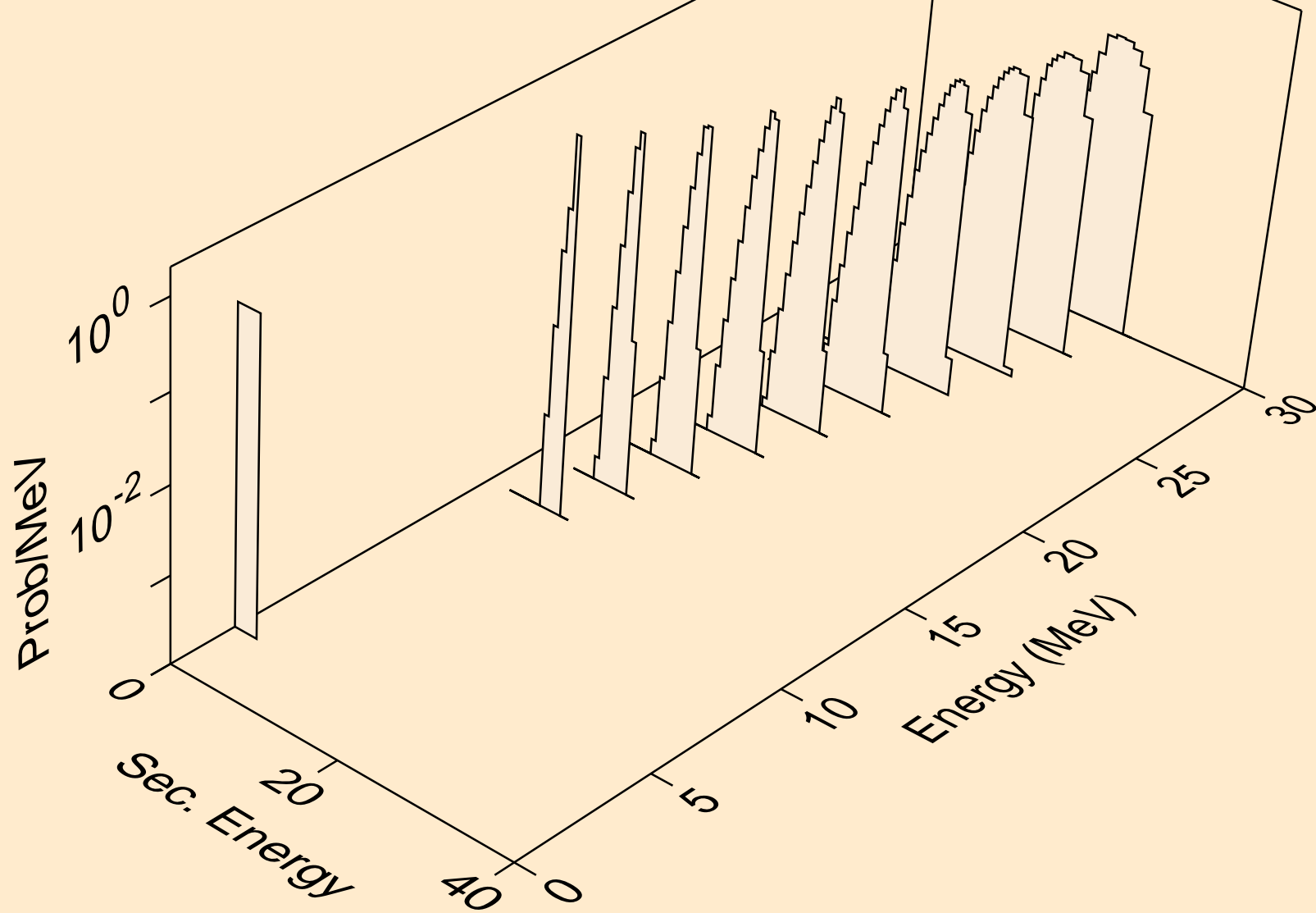

HF177N NEUTRON ACER TENDL-2024 LIBRARY; T=293.6K  
alphas from (n,x)

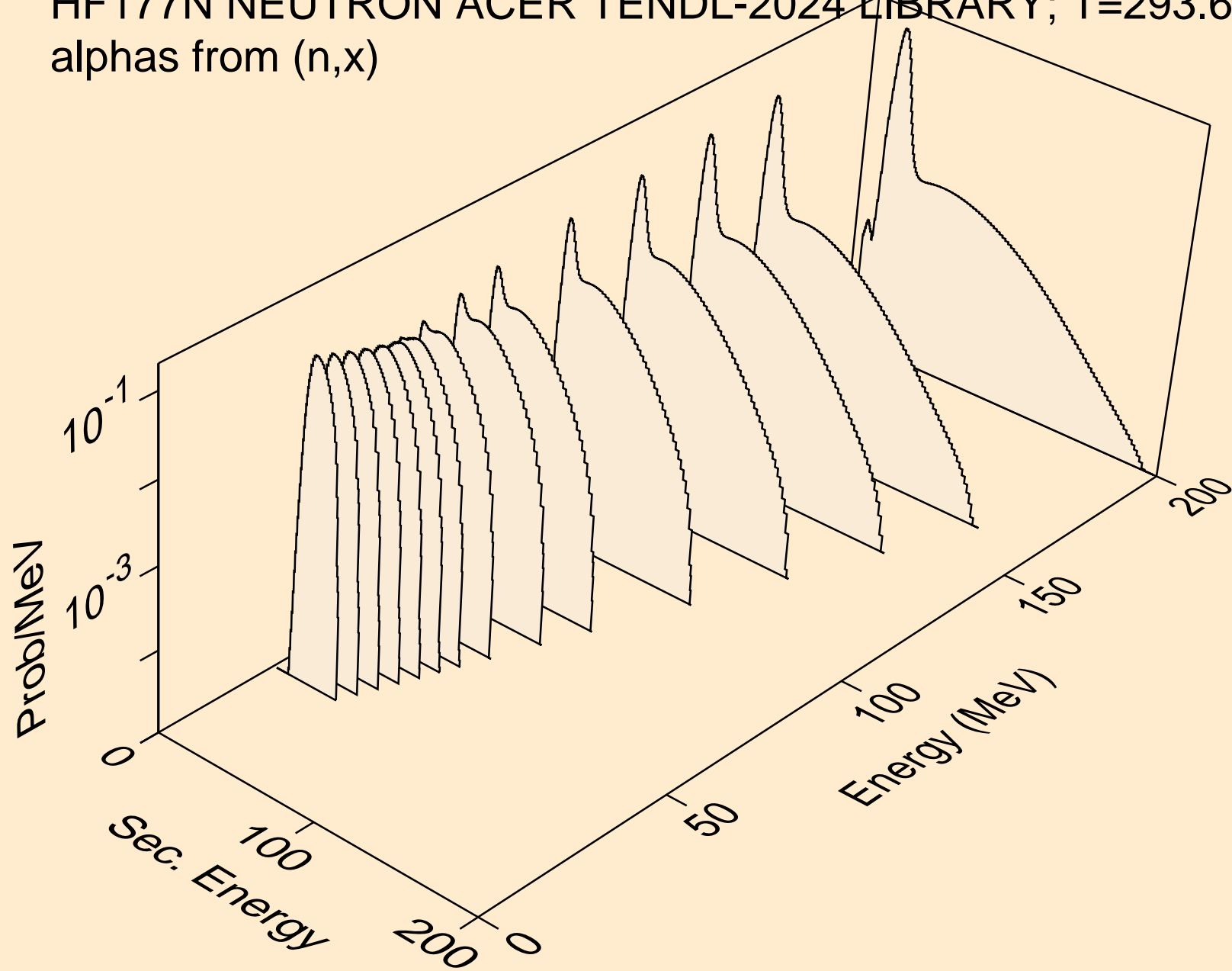

HF177N NEUTRON ACER TENDL-2024 LIBRARY; T=293.6K  
alphas from (n,n\*)a

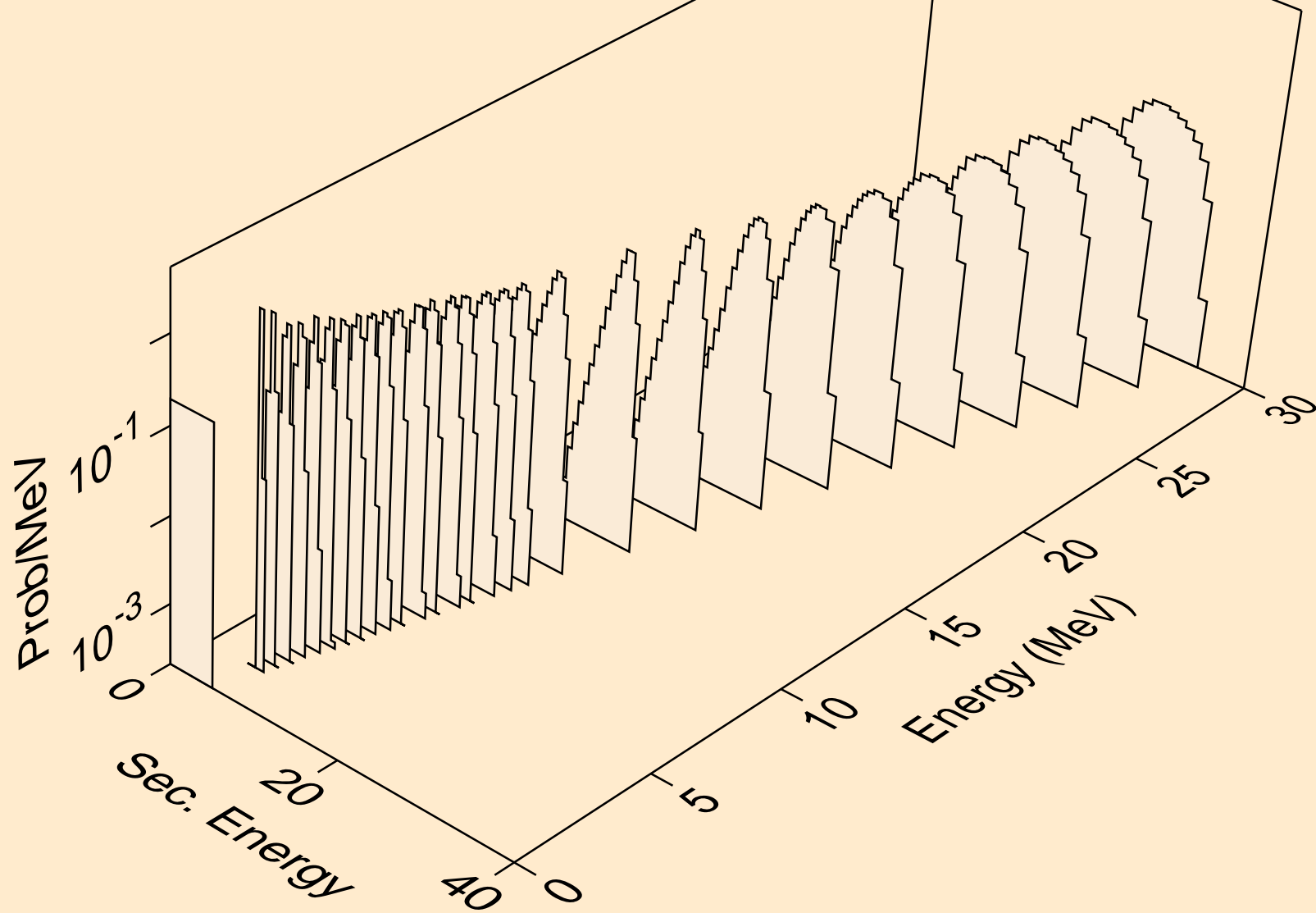

HF177N NEUTRON ACER TENDL-2024 LIBRARY; T=293.6K  
alphas from (n,2n)a

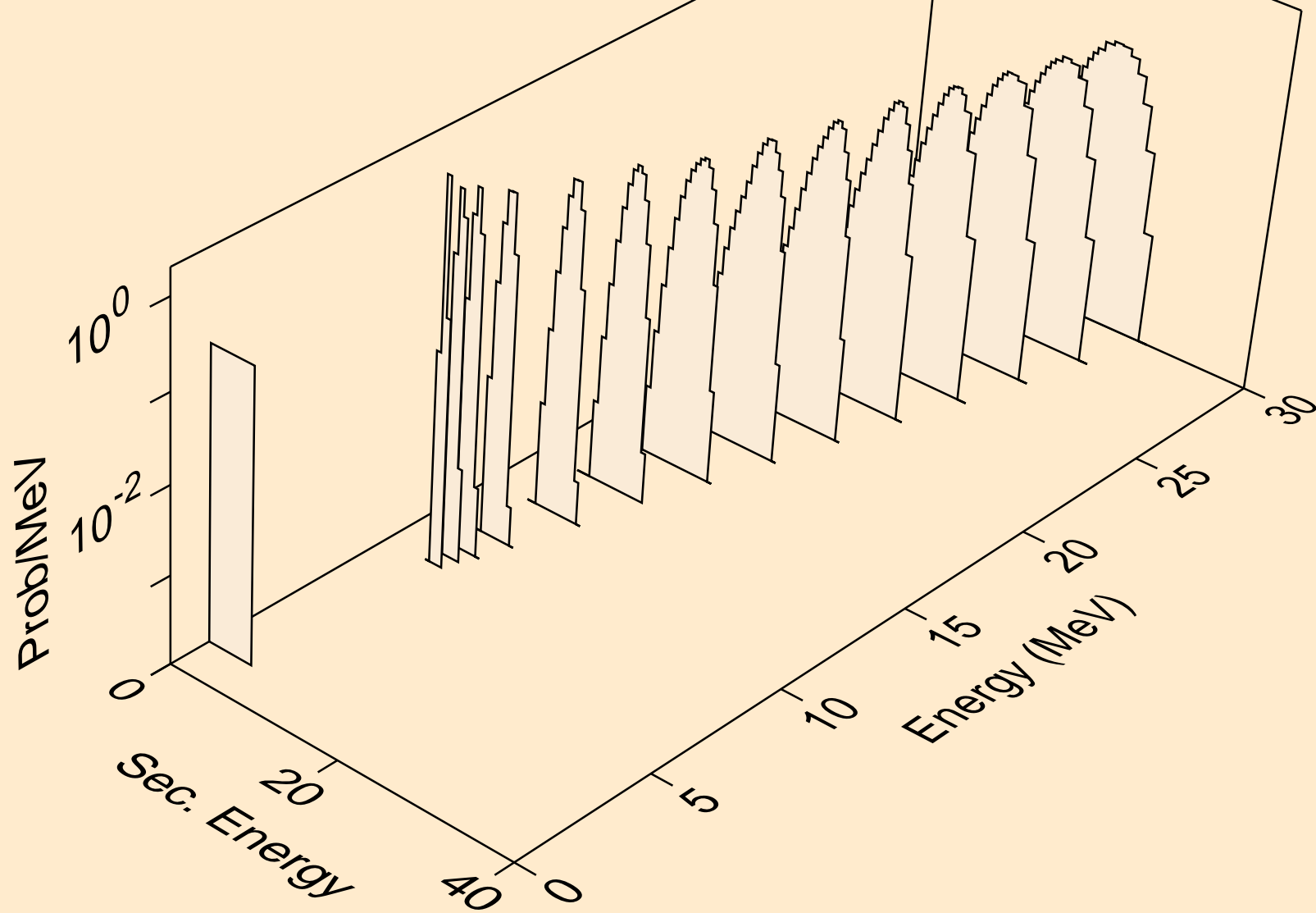

HF177N NEUTRON ACER TENDL-2024 LIBRARY; T=293.6K  
alphas from (n,3n)a

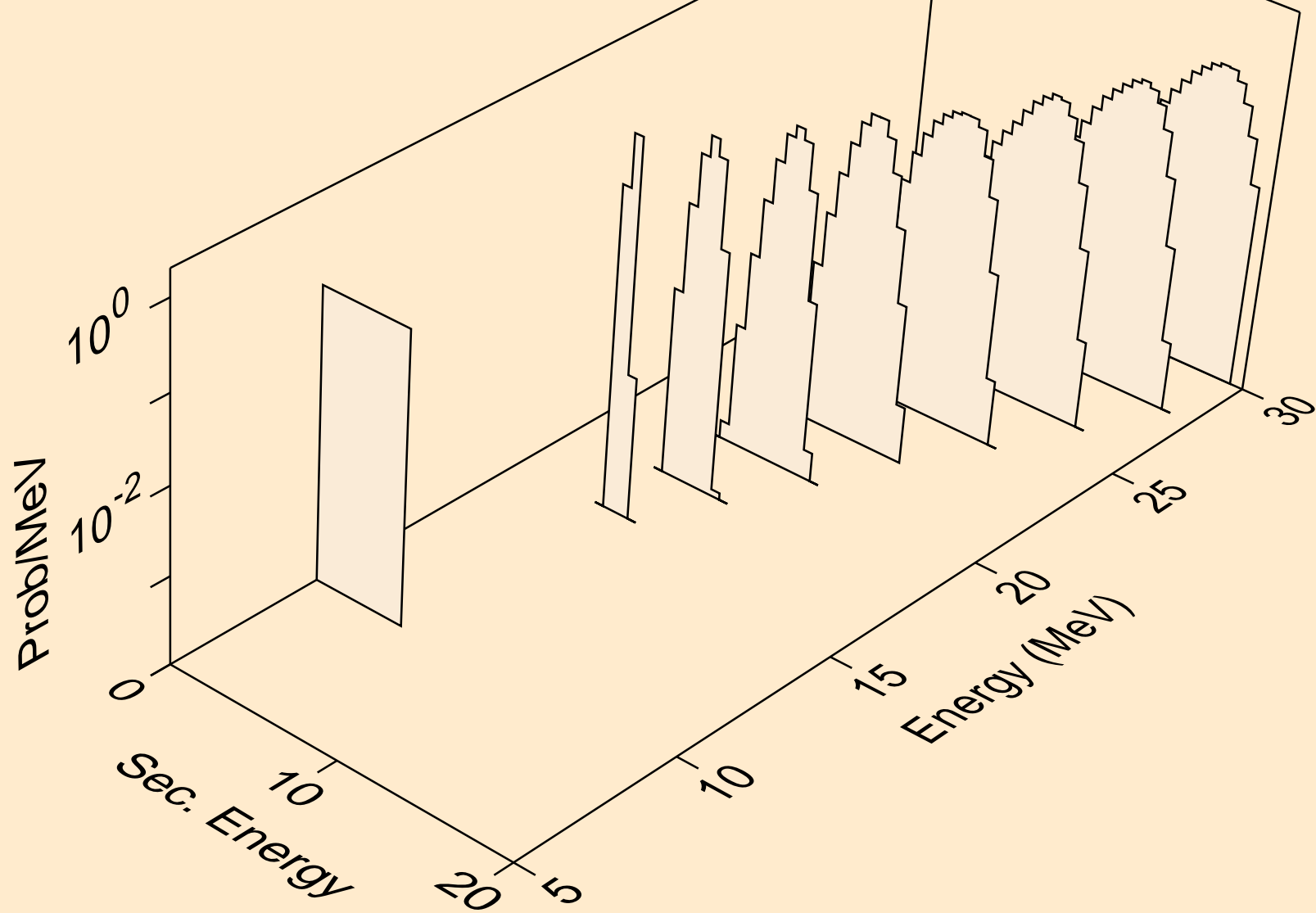

HF177N NEUTRON ACER TENDL-2024 LIBRARY; T=293.6K  
alphas from (n,n\*)2a

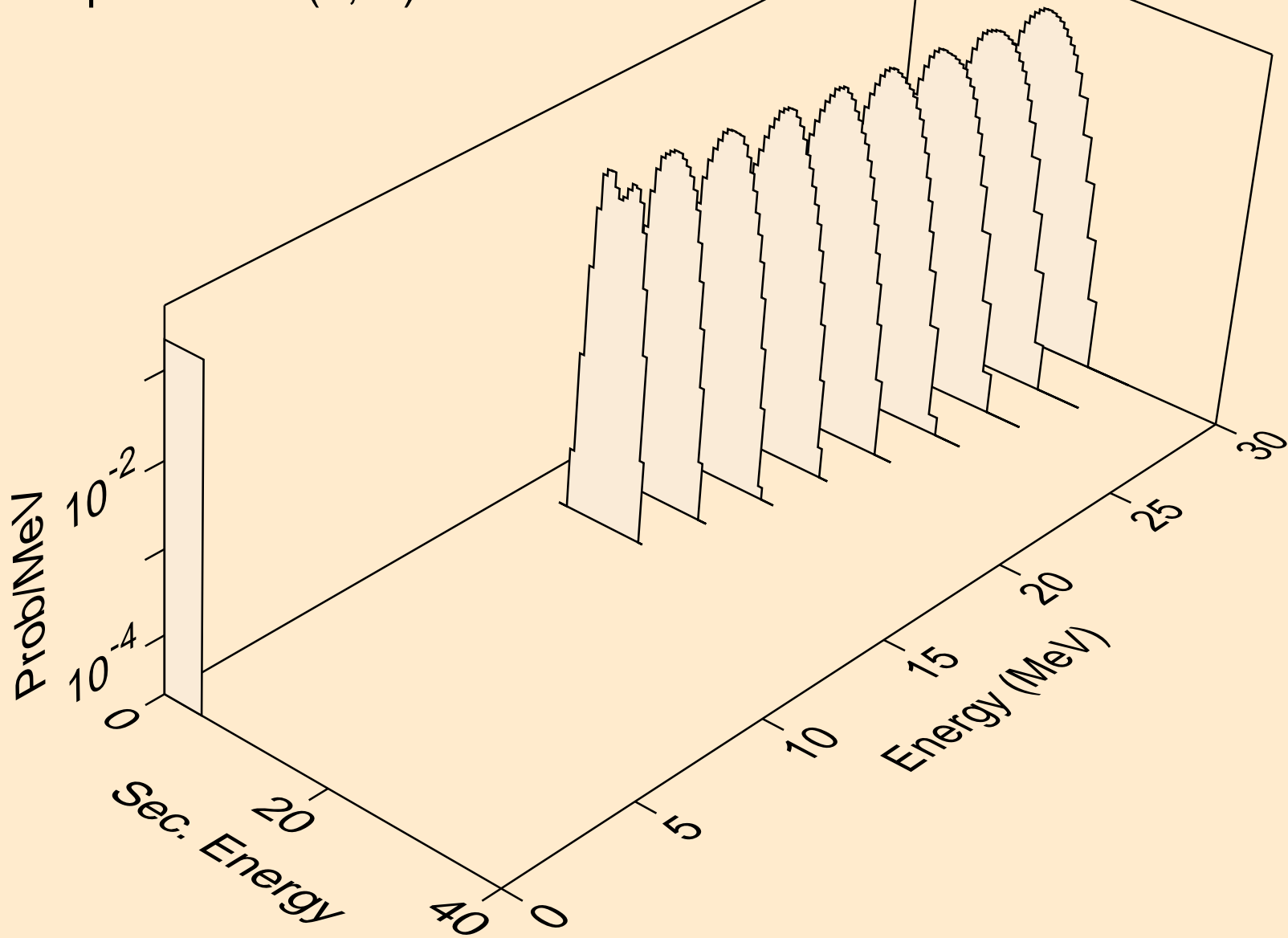

HF177N NEUTRON ACER TENDL-2024 LIBRARY; T=293.6K  
alphas from (n,npa)

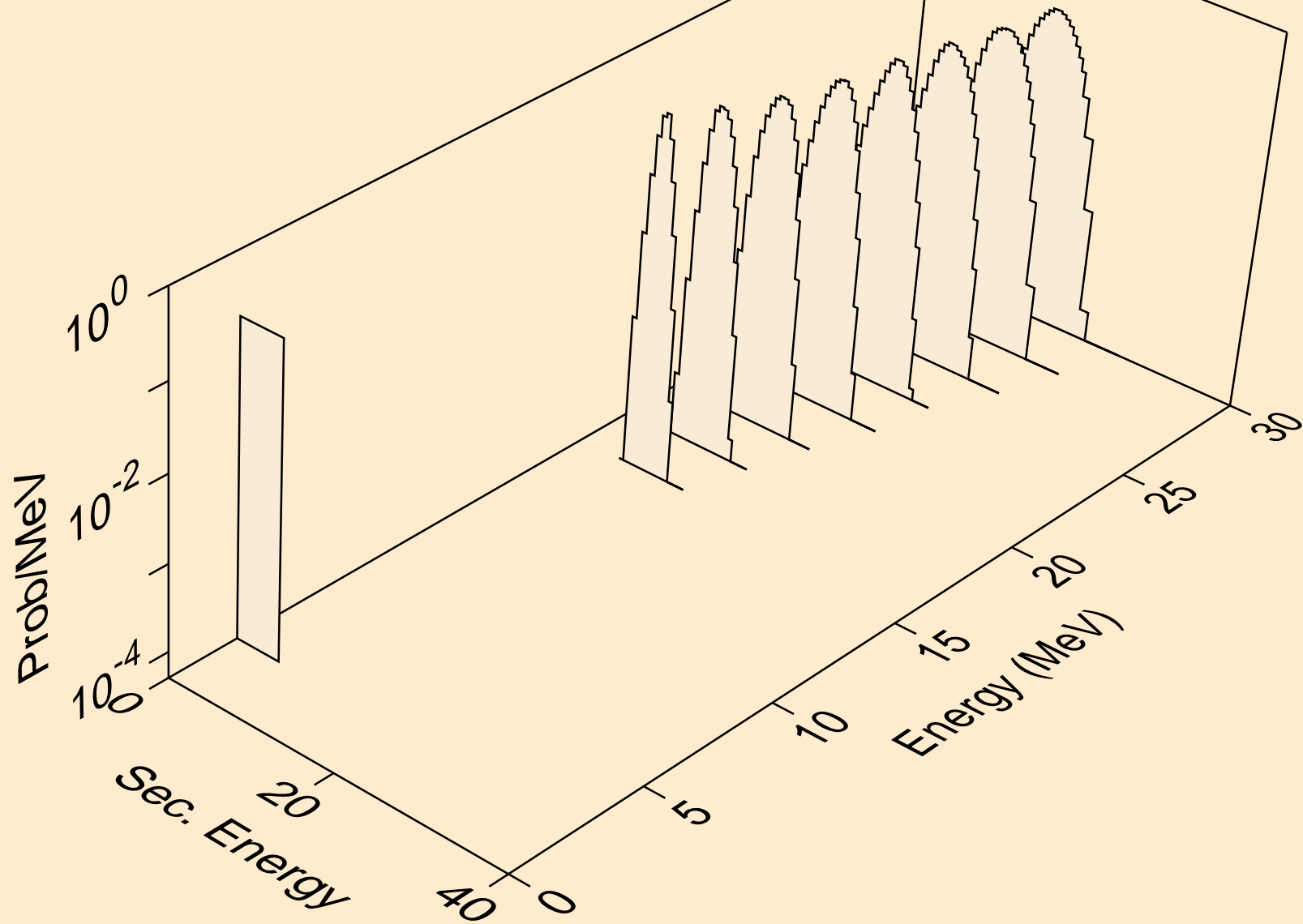

HF177N NEUTRON ACER TENDL-2024 LIBRARY; T=293.6K  
alphas from (n,a)

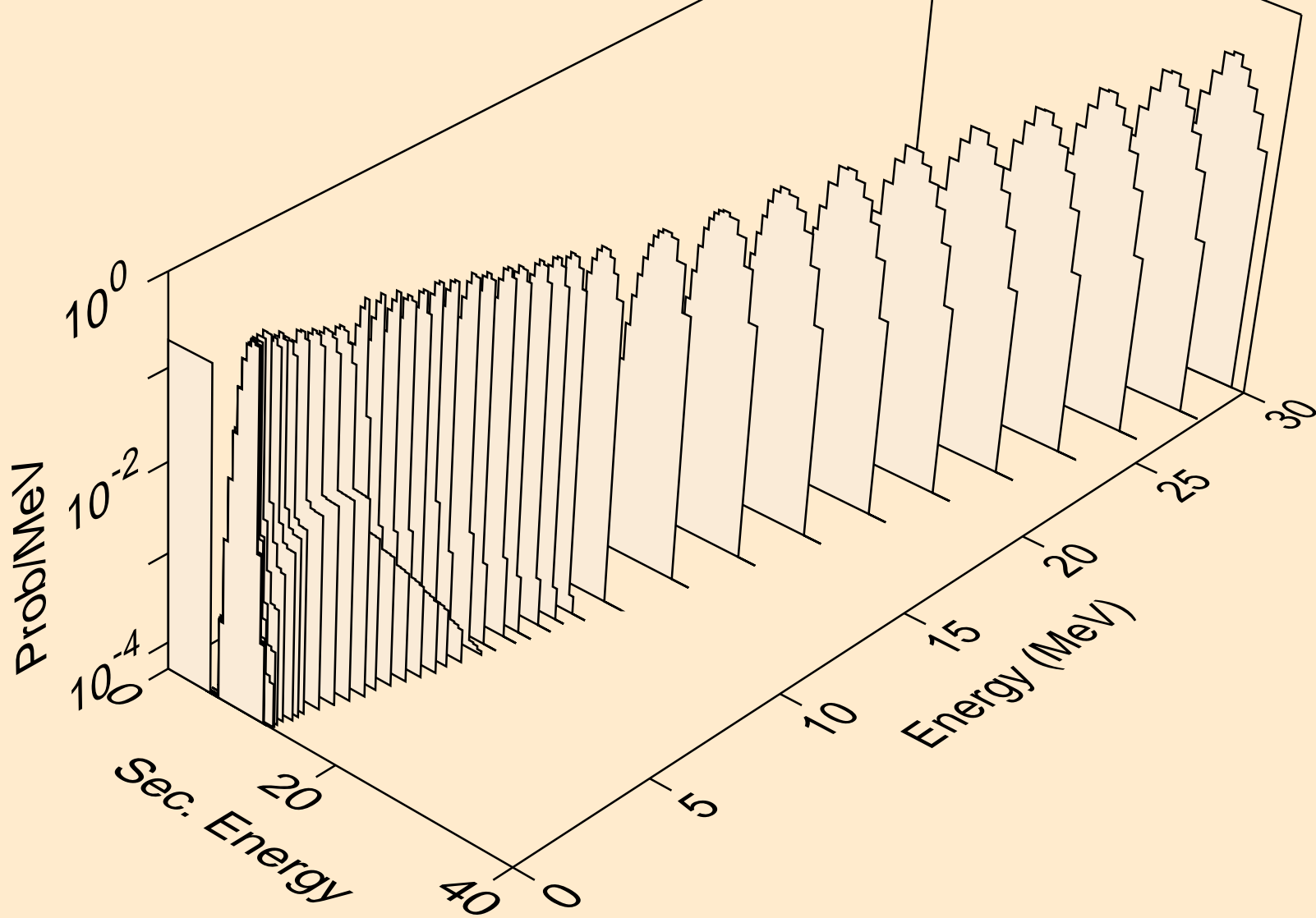

HF177N NEUTRON ACER TENDL-2024 LIBRARY; T=293.6K  
alphas from (n,2a)

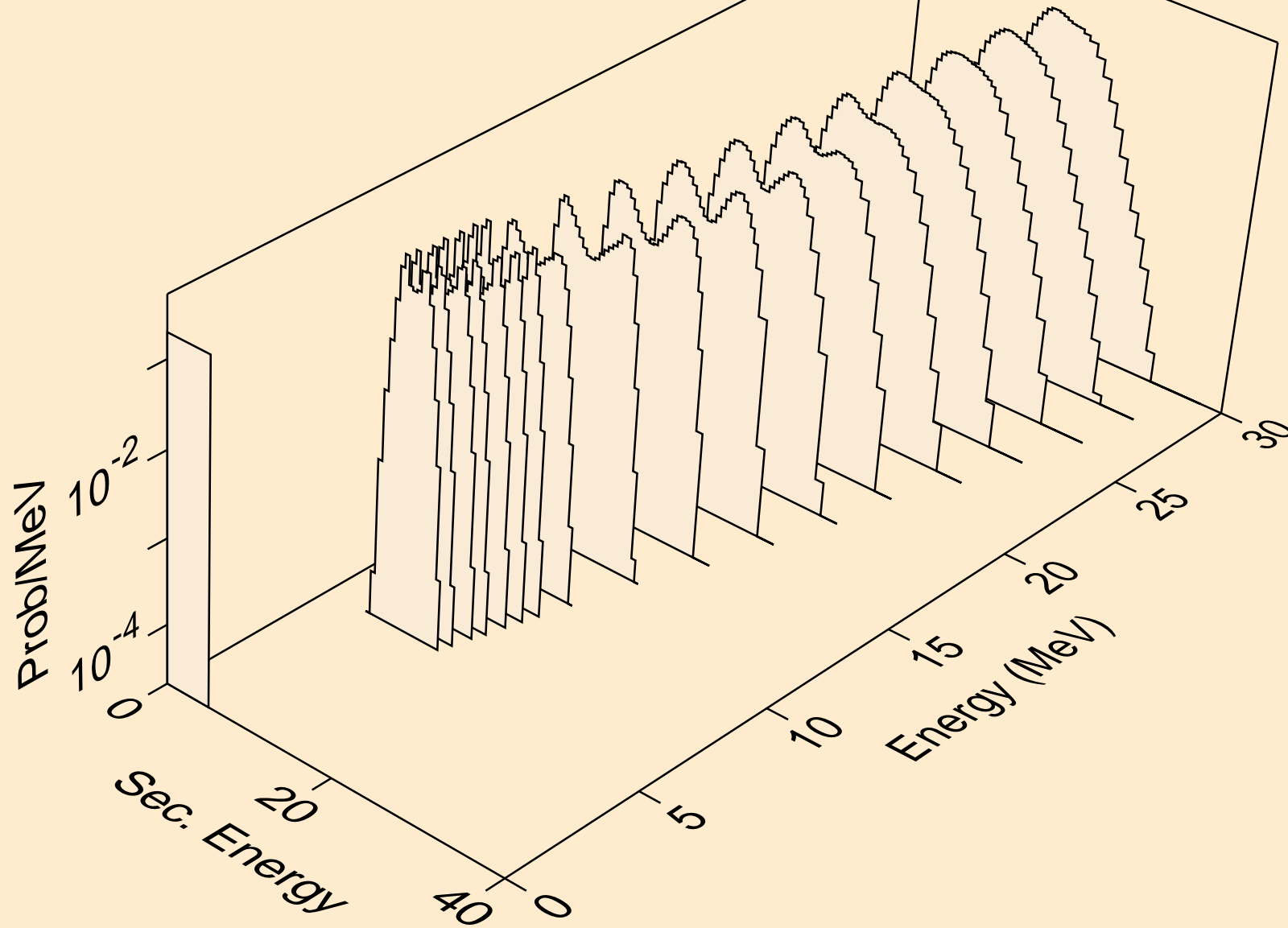

HF177N NEUTRON ACER TENDL-2024 LIBRARY; T=293.6K  
alphas from (n,pa)

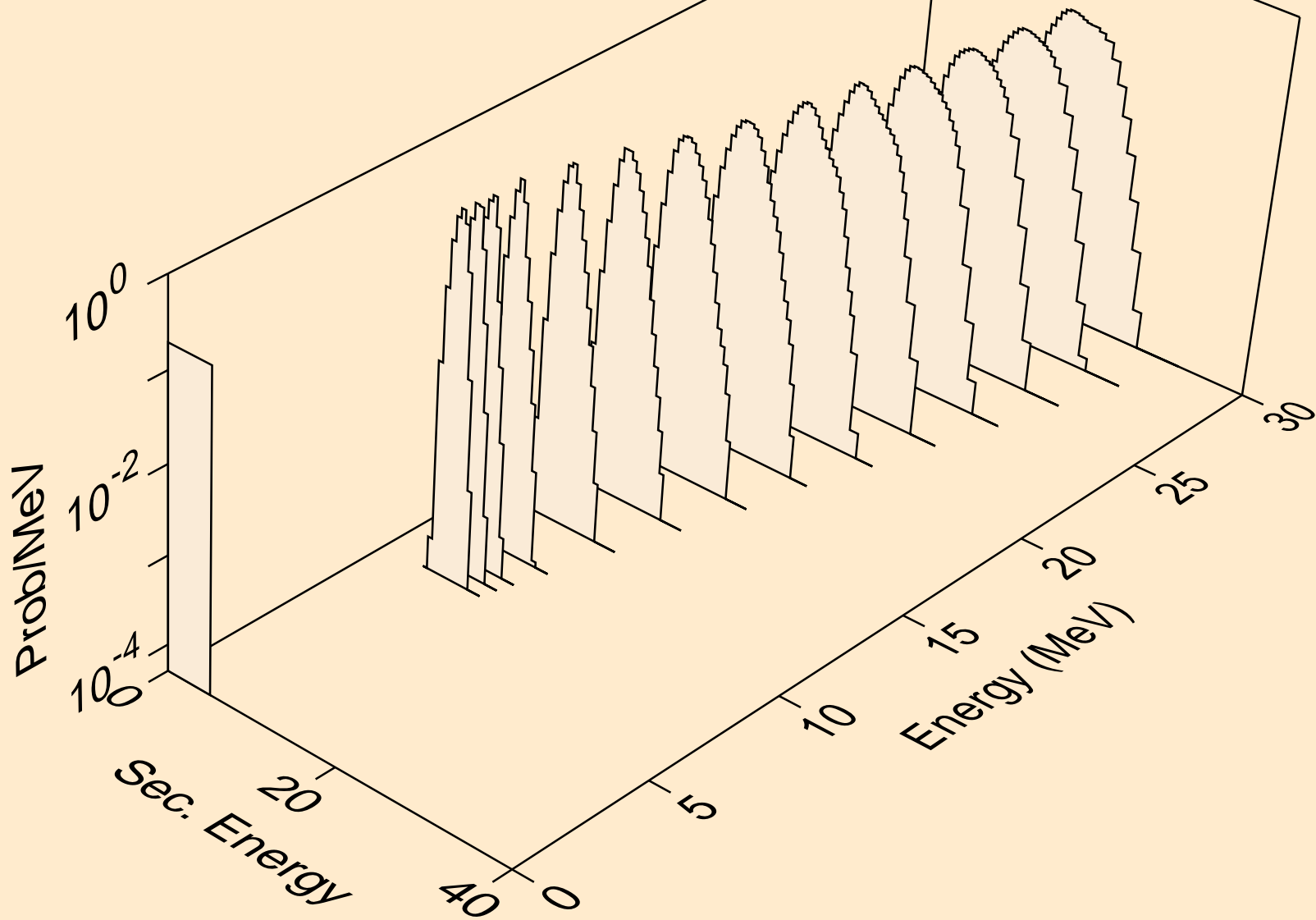

HF177N NEUTRON ACER TENDL-2024 LIBRARY; T=293.6K  
alphas from (n,da)

