

PB199 NEUTRON ACER TENDL-2024 LIBRARY; T=293.6K  
Principal cross sections

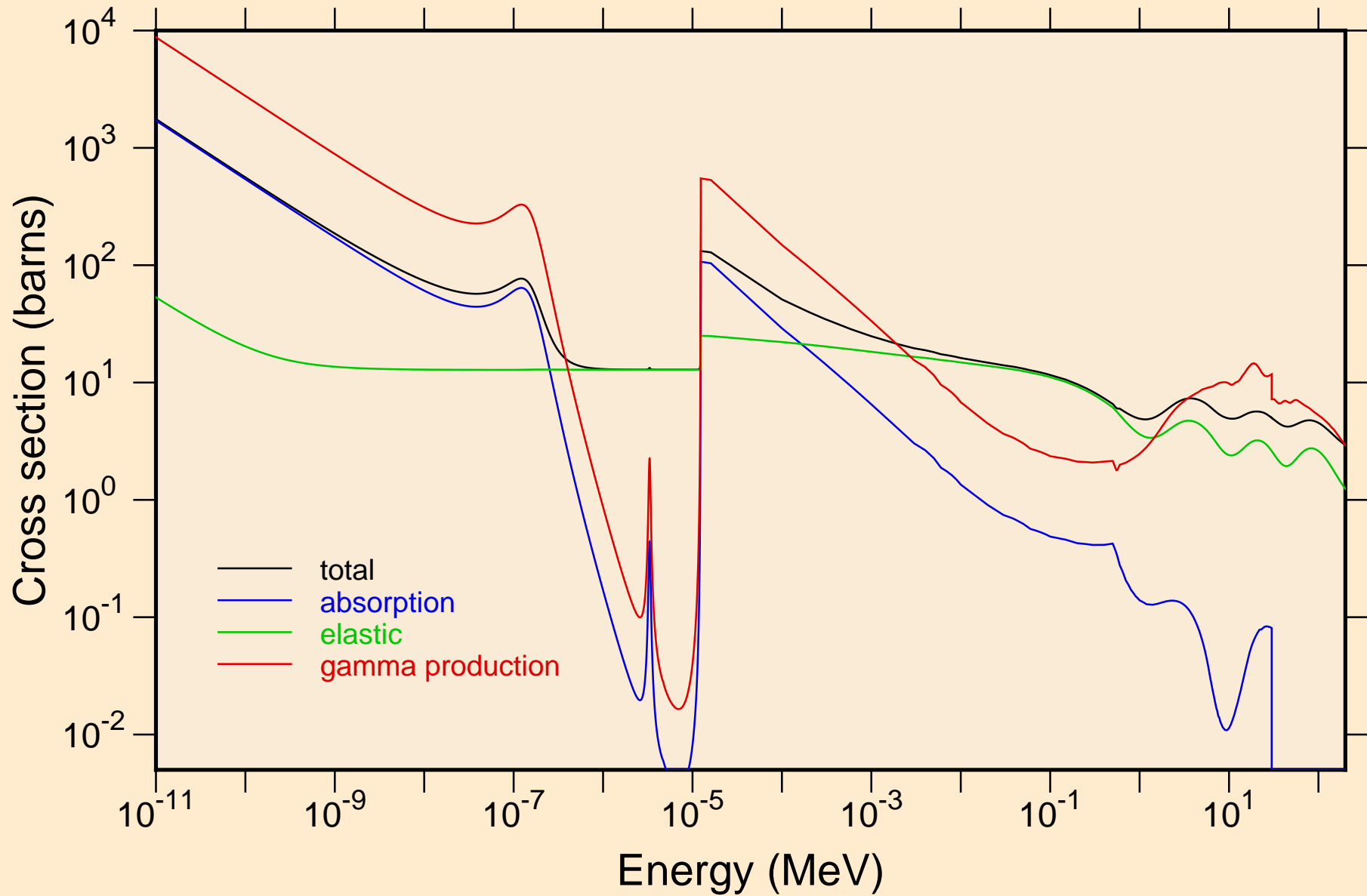

PB199 NEUTRON ACER TENDL-2024 LIBRARY; T=293.6K  
Heating

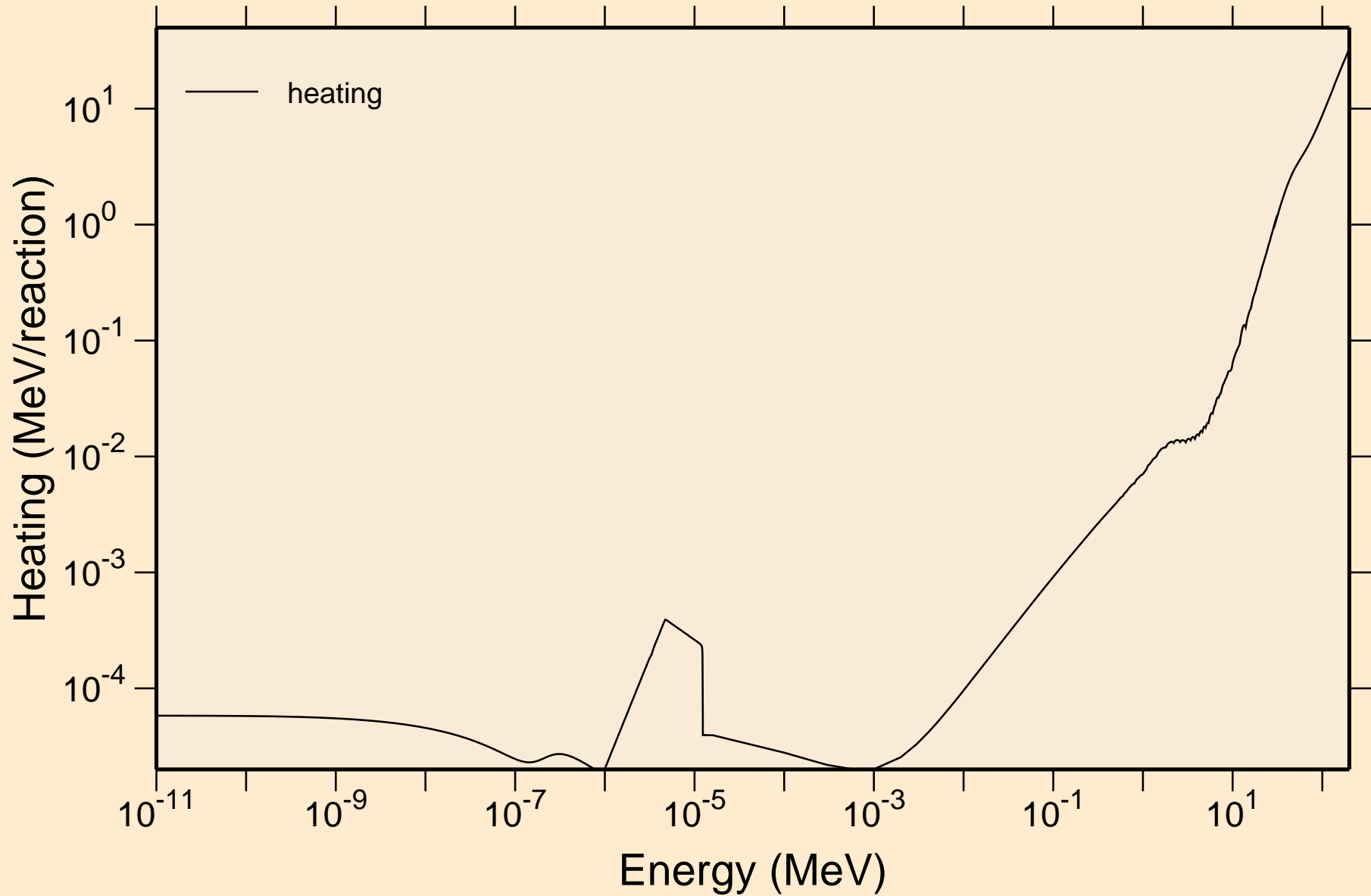

PB199 NEUTRON ACER TENDL-2024 LIBRARY; T=293.6K  
Damage

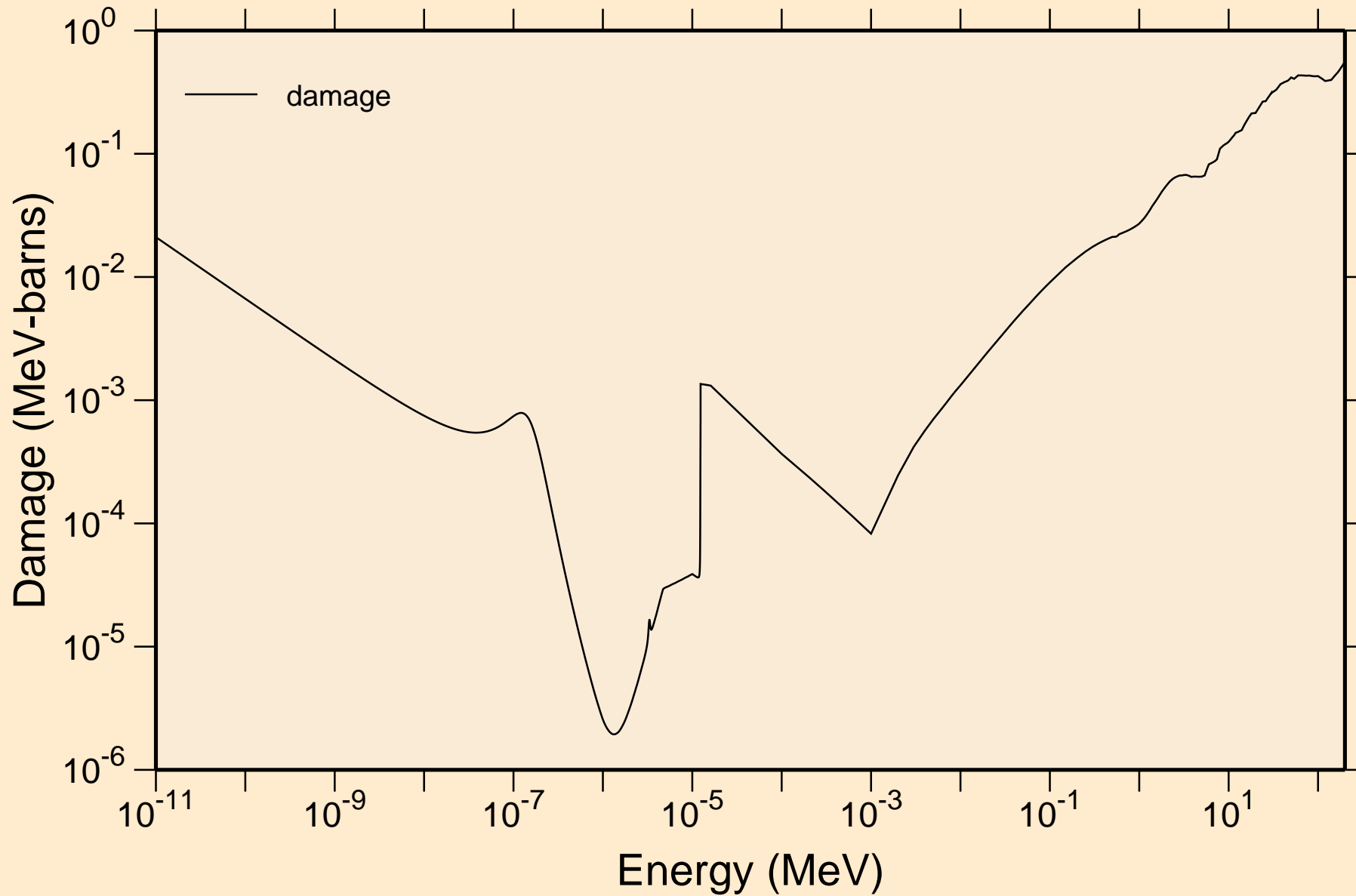

PB199 NEUTRON ACER TENDL-2024 LIBRARY; T=293.6K  
Non-threshold reactions

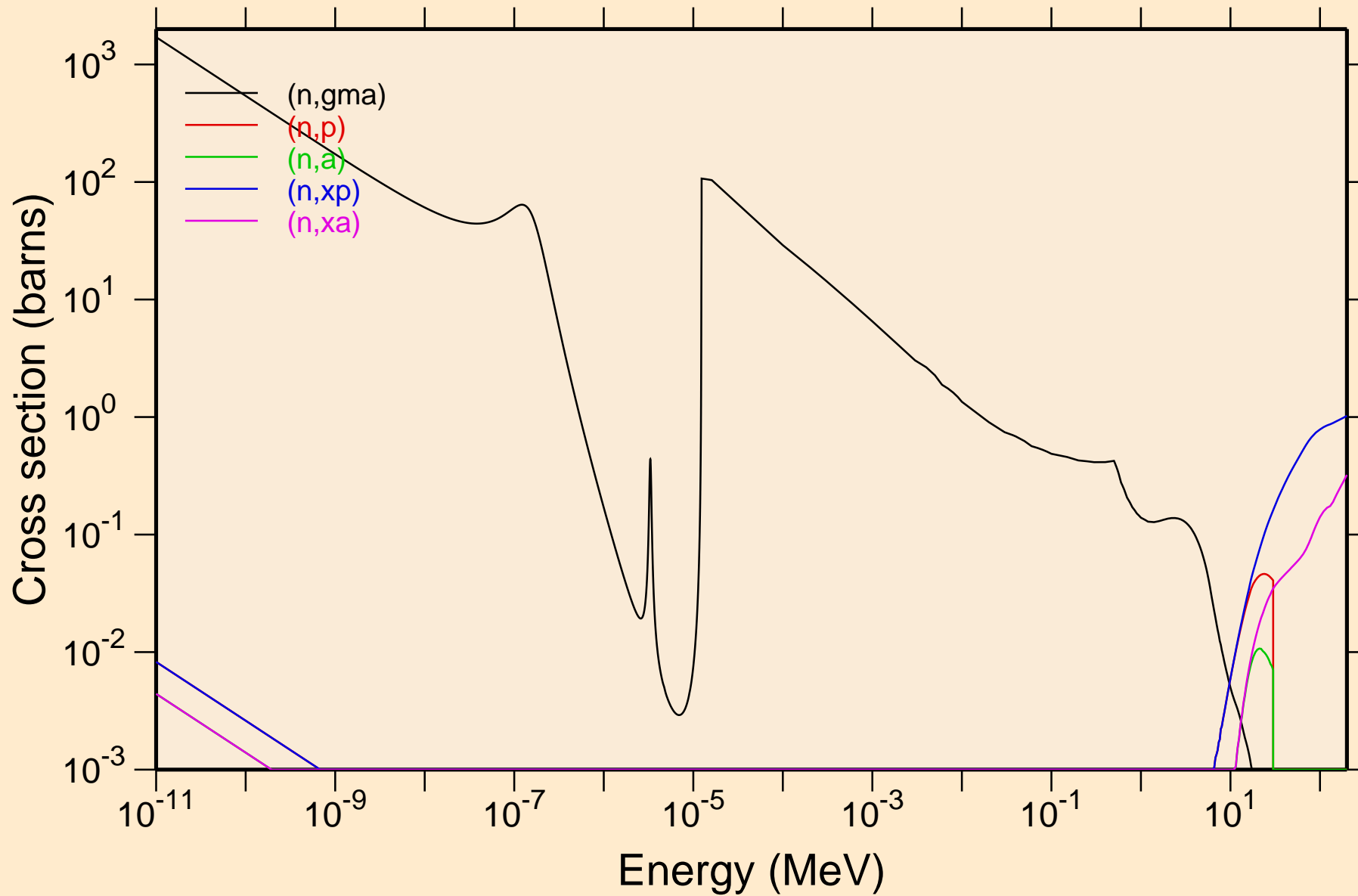

PB199 NEUTRON ACER TENDL-2024 LIBRARY; T=293.6K  
Principal cross sections

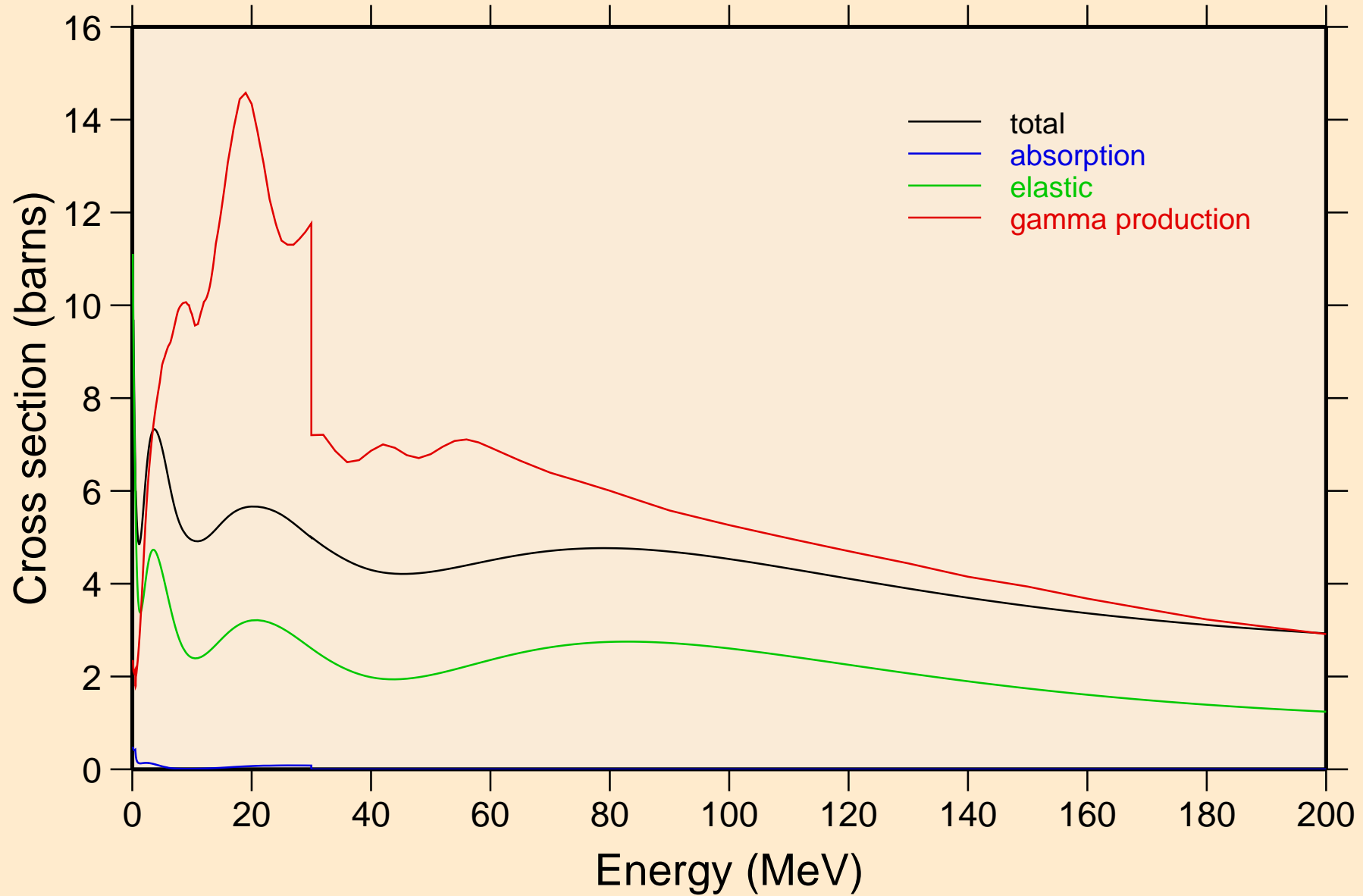

PB199 NEUTRON ACER TENDL-2024 LIBRARY; T=293.6K  
Heating

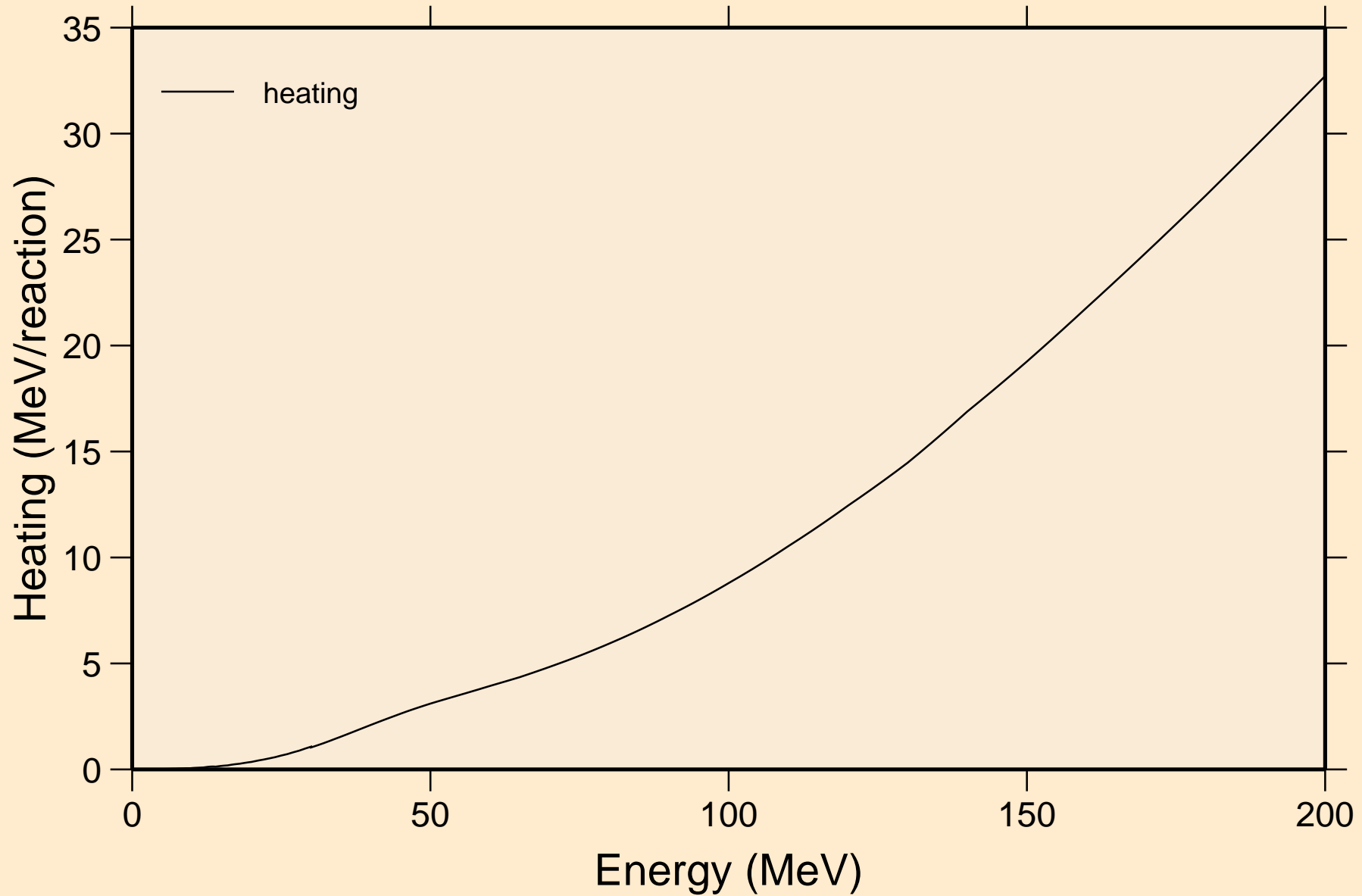

PB199 NEUTRON ACER TENDL-2024 LIBRARY; T=293.6K  
Damage

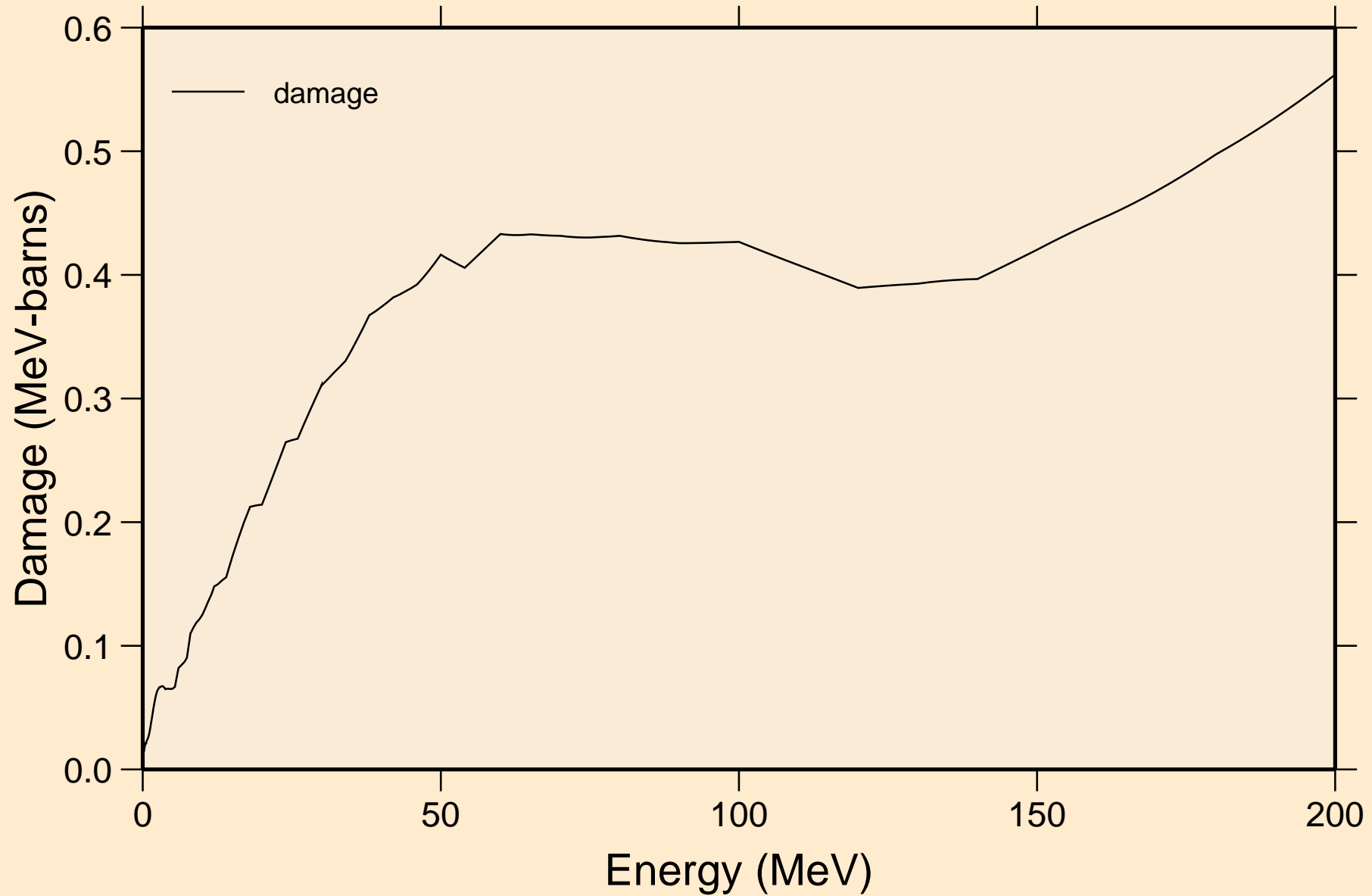

PB199 NEUTRON ACER TENDL-2024 LIBRARY; T=293.6K  
Non-threshold reactions

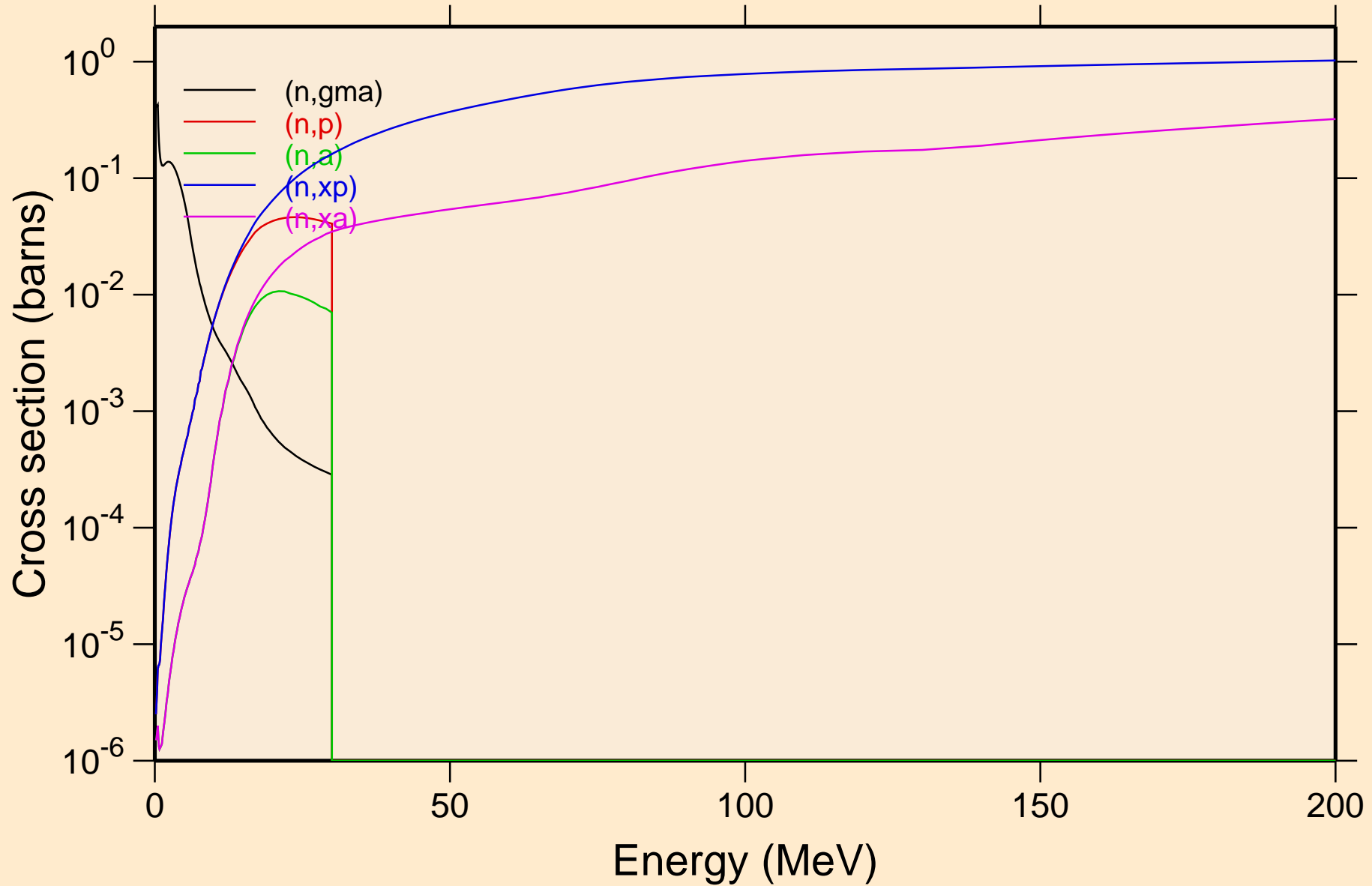

PB199 NEUTRON ACER TENDL-2024 LIBRARY; T=293.6K  
Inelastic levels

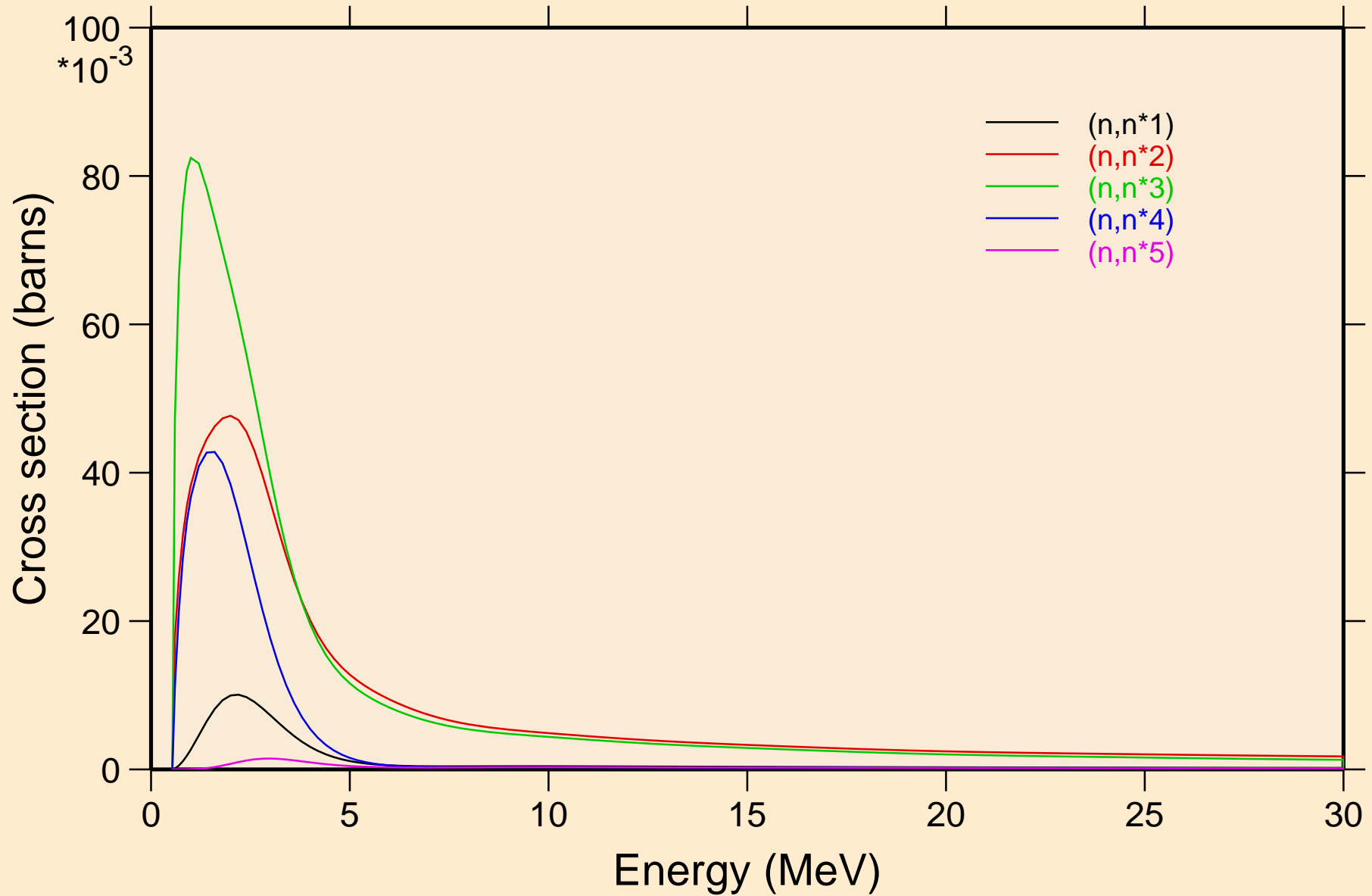

PB199 NEUTRON ACER TENDL-2024 LIBRARY; T=293.6K  
Inelastic levels

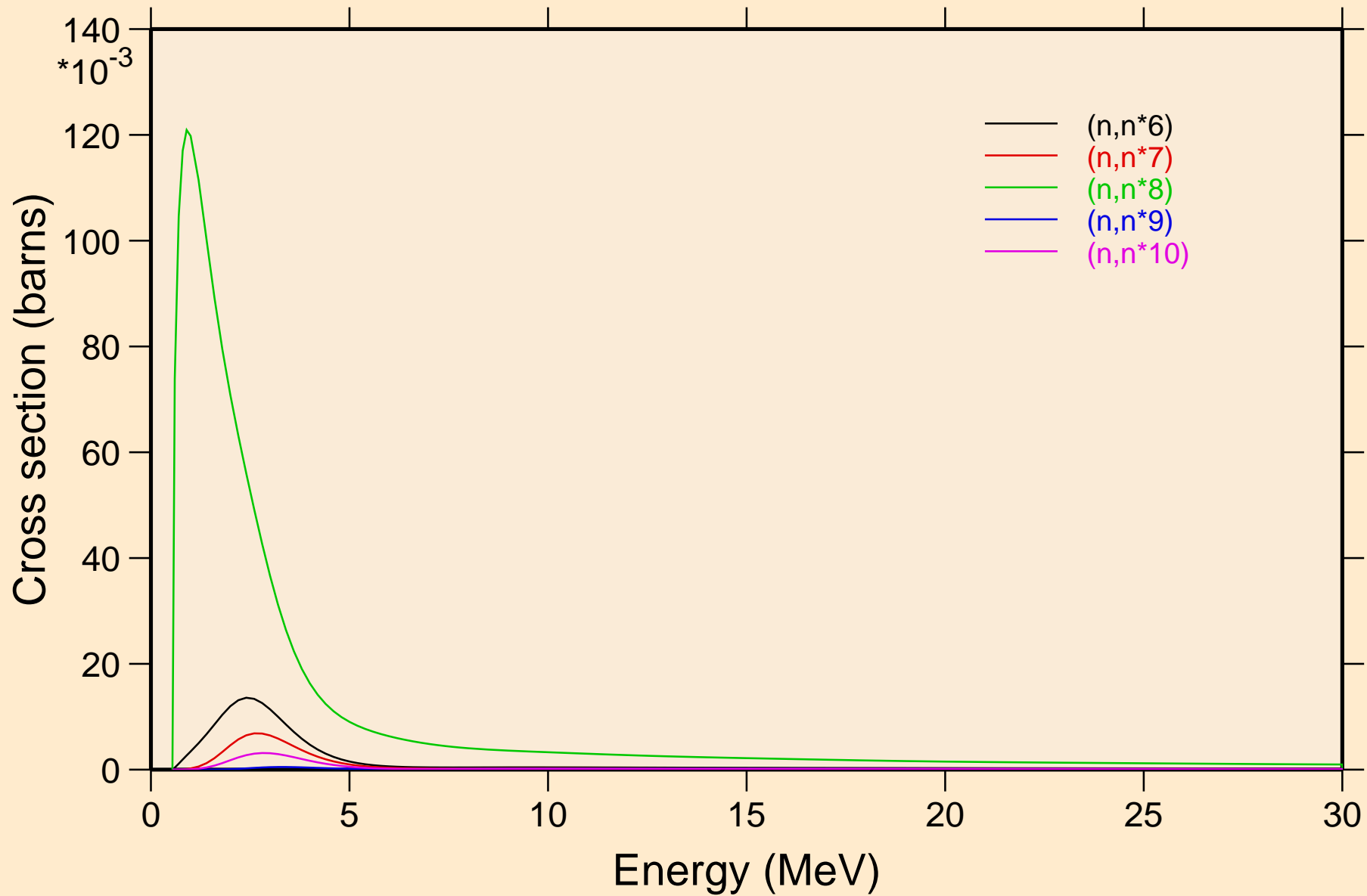

PB199 NEUTRON ACER TENDL-2024 LIBRARY; T=293.6K  
Inelastic levels

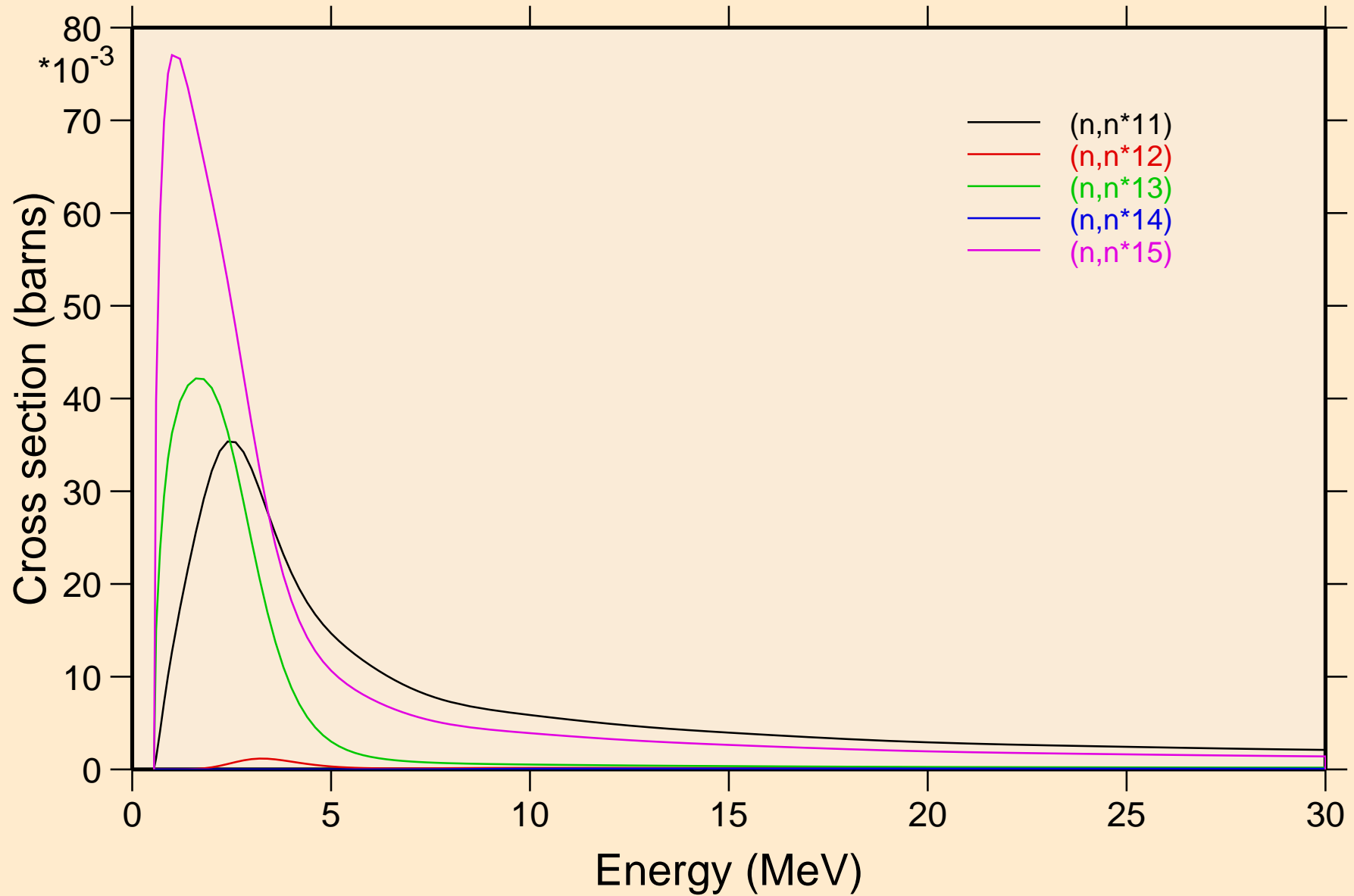

PB199 NEUTRON ACER TENDL-2024 LIBRARY; T=293.6K  
Inelastic levels

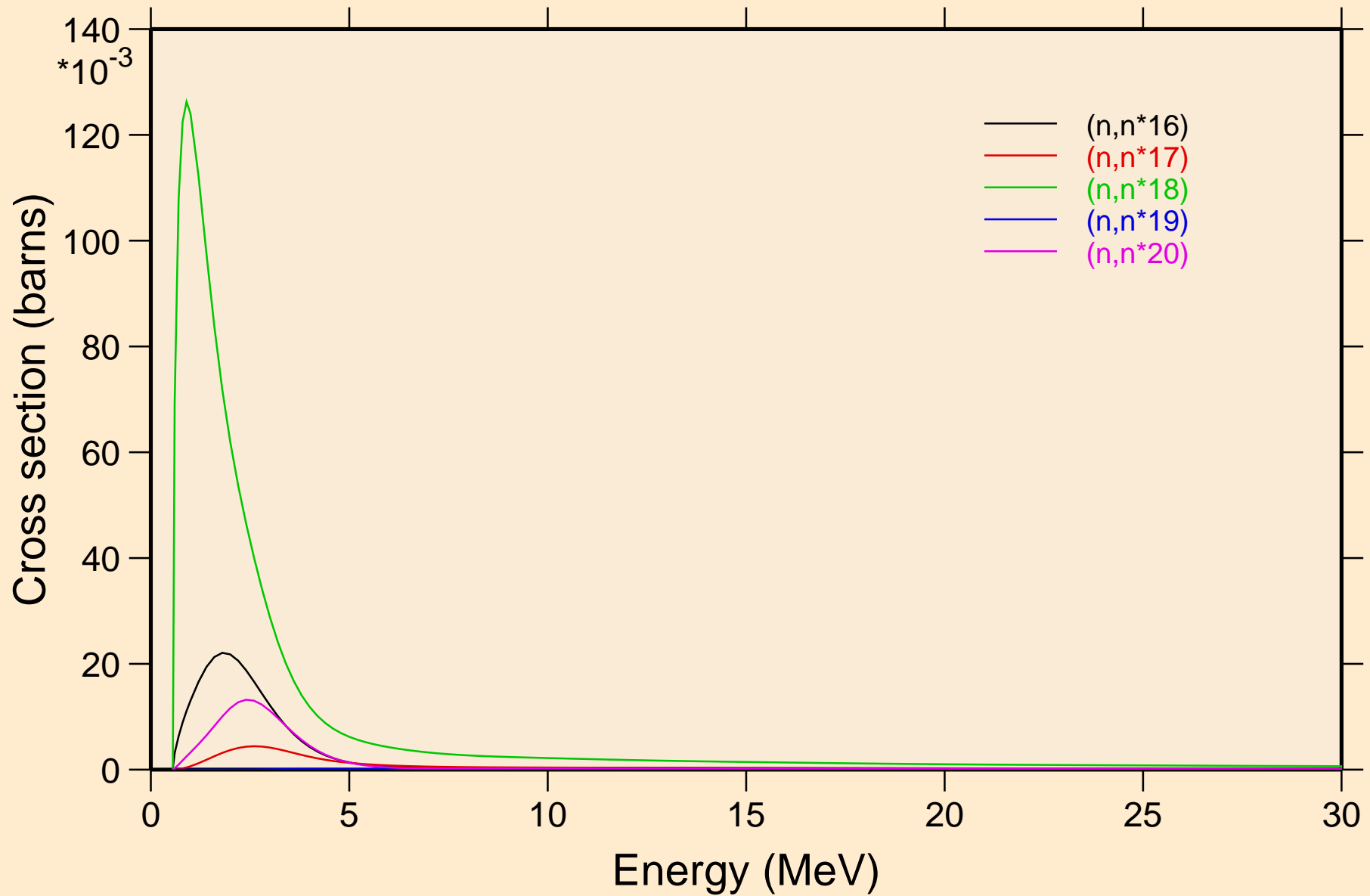

PB199 NEUTRON ACER TENDL-2024 LIBRARY; T=293.6K  
Inelastic levels

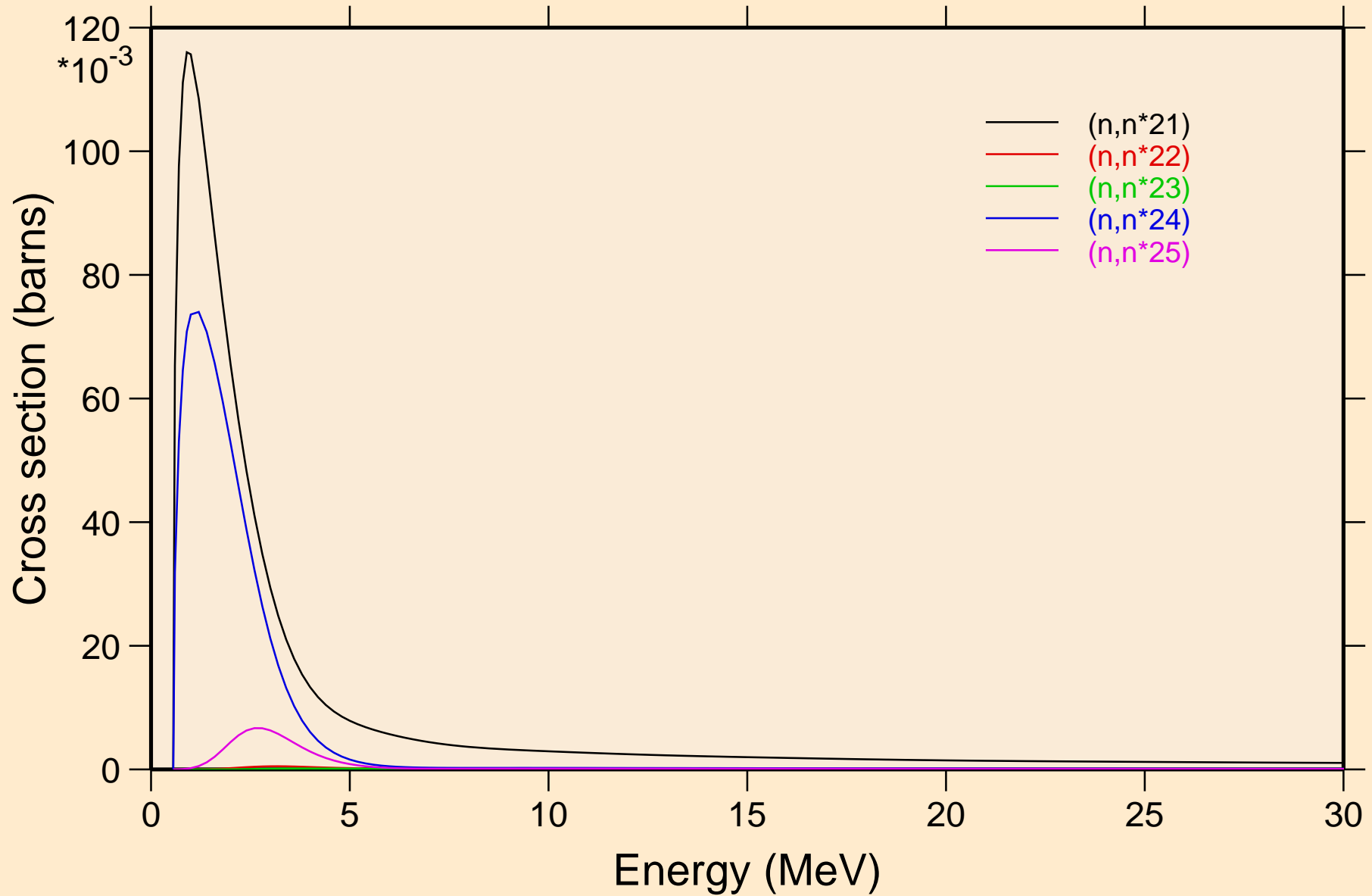

PB199 NEUTRON ACER TENDL-2024 LIBRARY; T=293.6K  
Inelastic levels

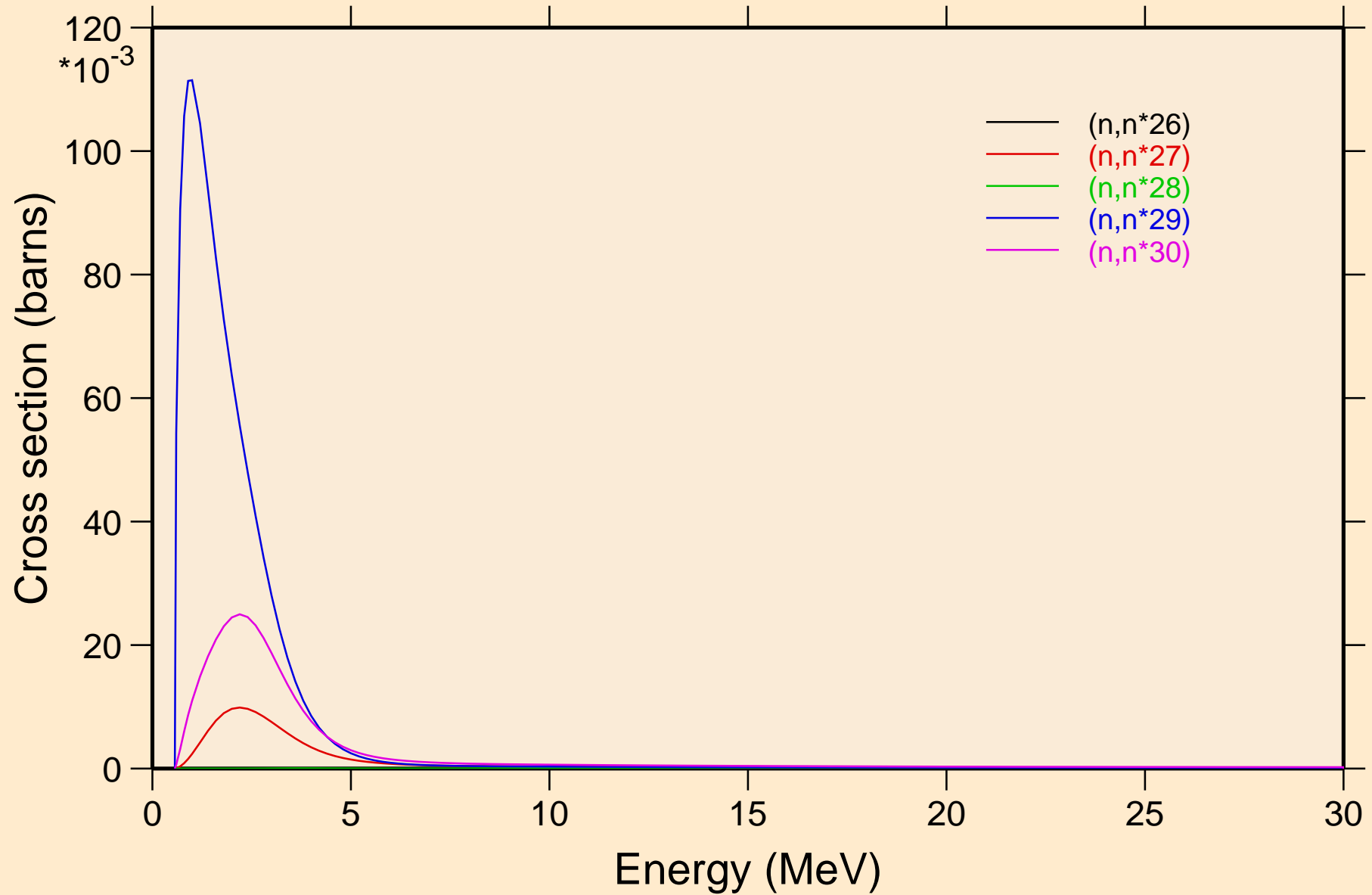

PB199 NEUTRON ACER TENDL-2024 LIBRARY; T=293.6K  
Threshold reactions

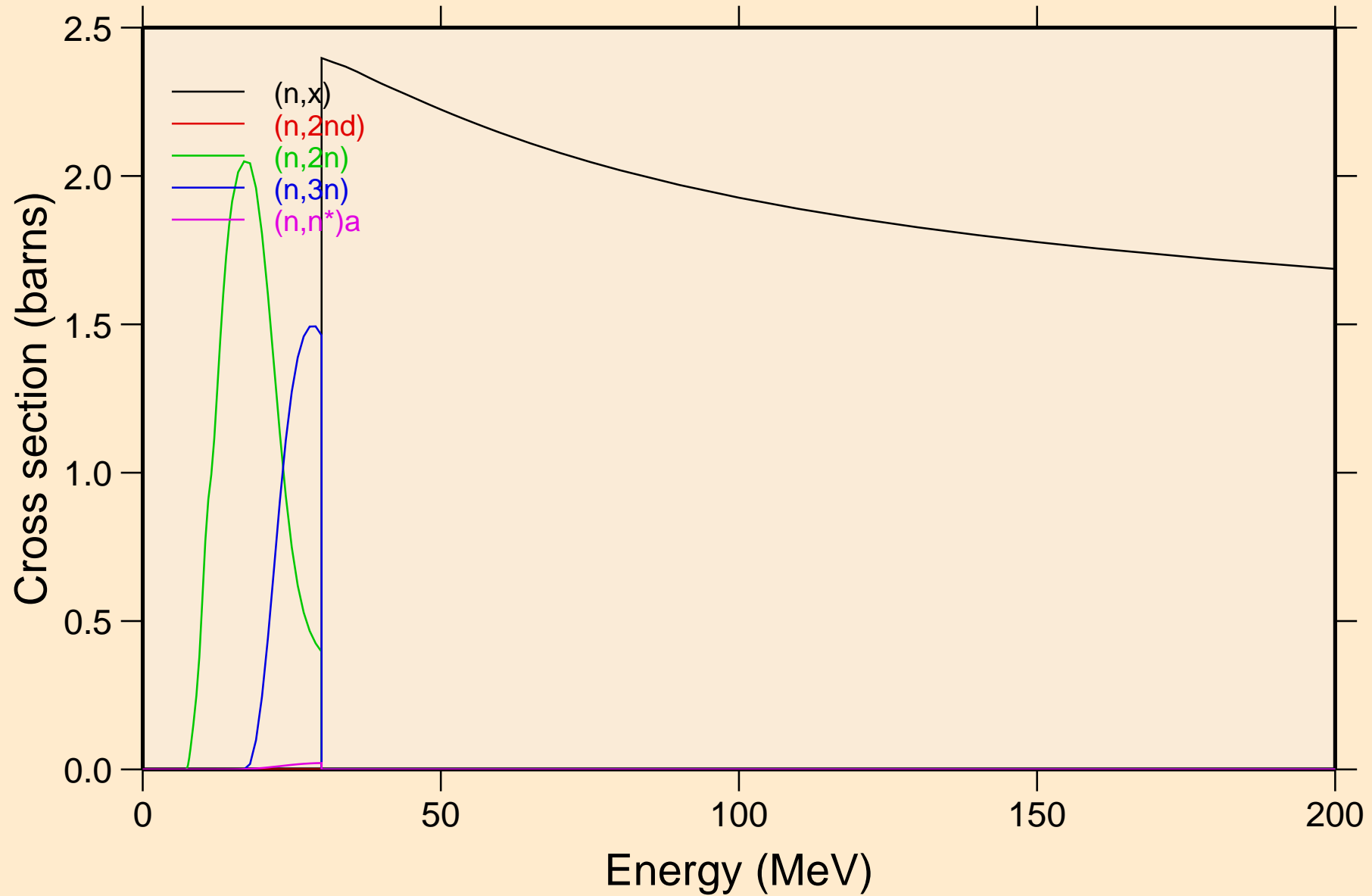

PB199 NEUTRON ACER TENDL-2024 LIBRARY; T=293.6K  
Threshold reactions

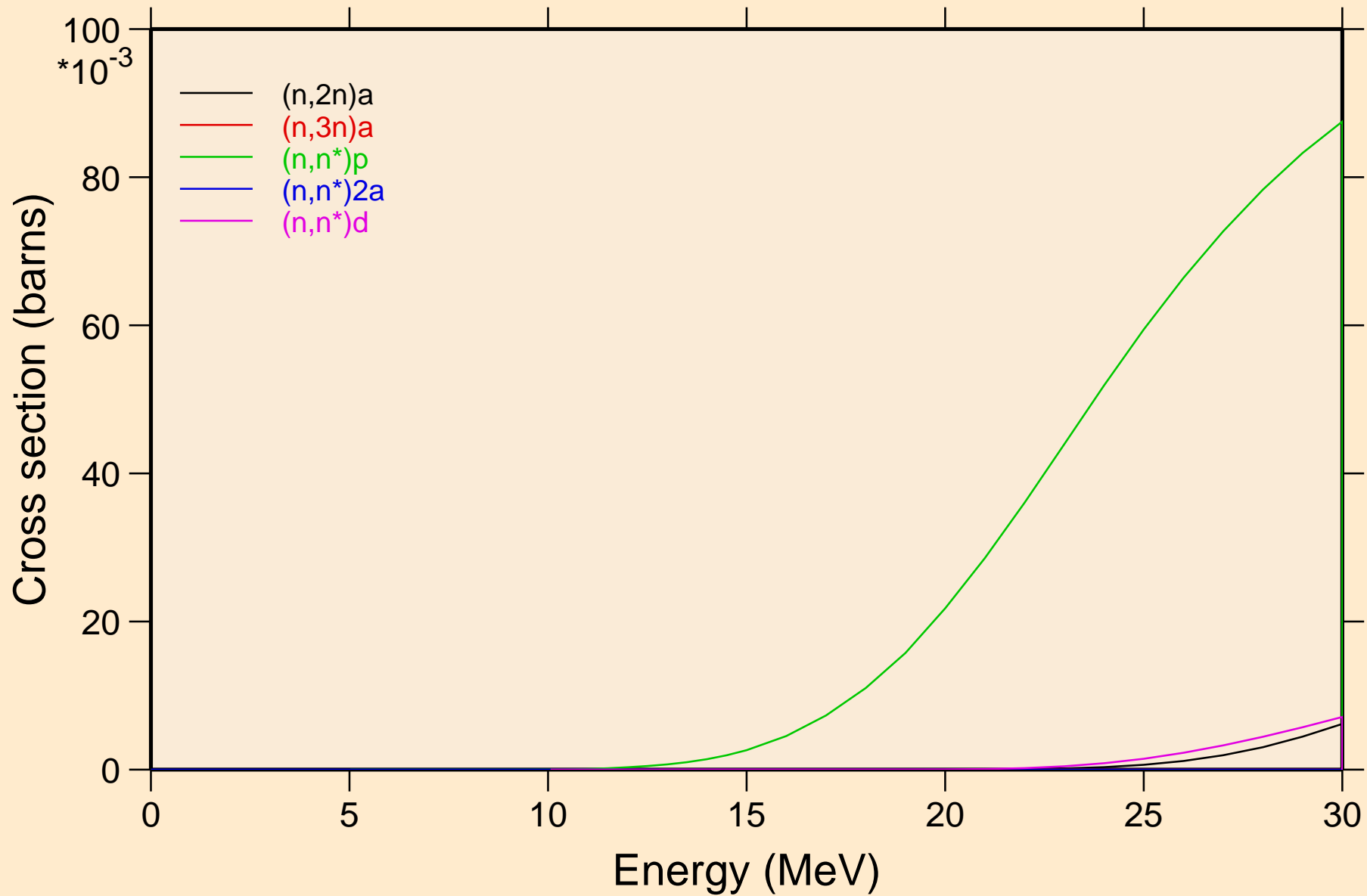

PB199 NEUTRON ACER TENDL-2024 LIBRARY; T=293.6K  
Threshold reactions

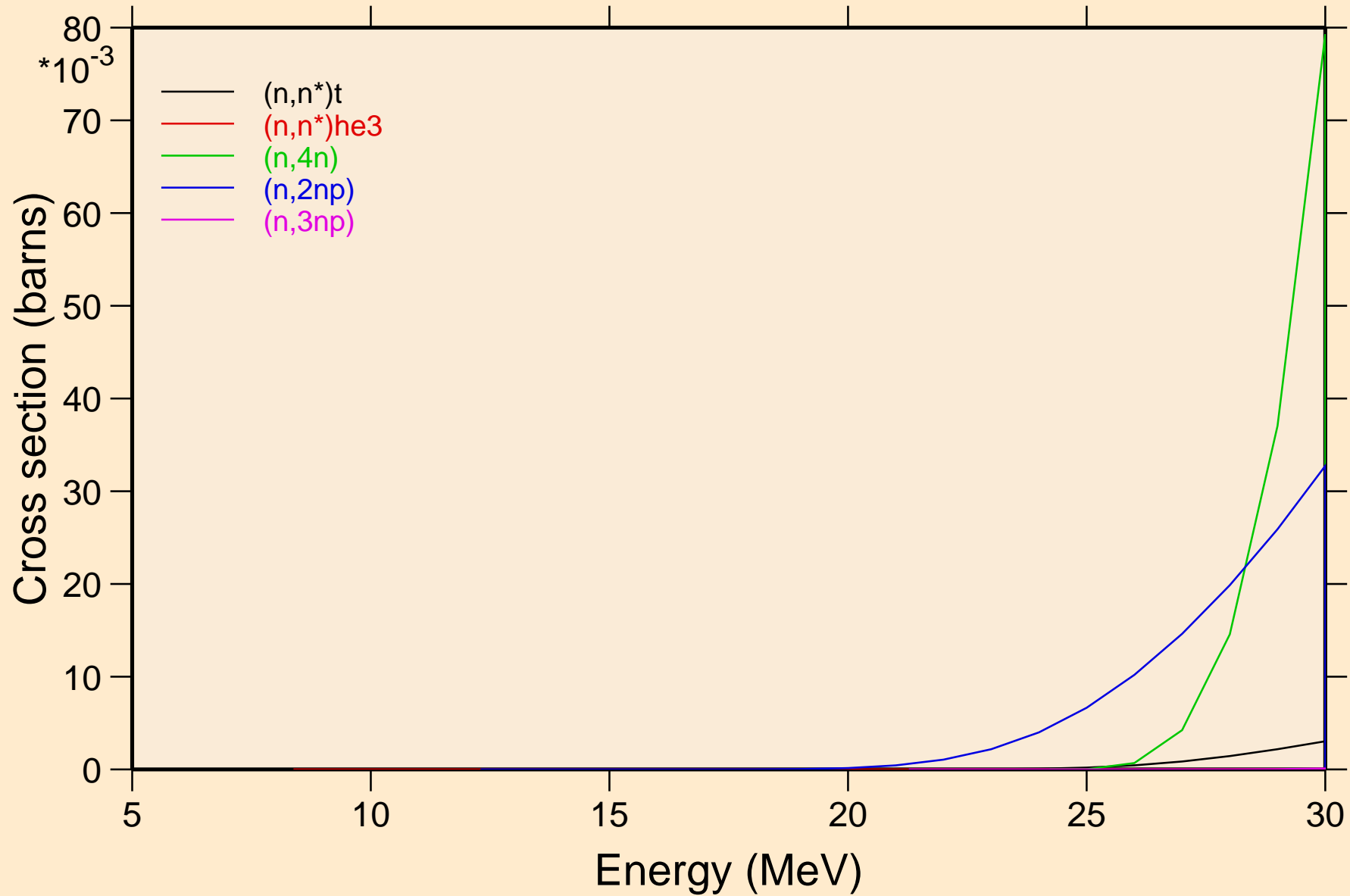

PB199 NEUTRON ACER TENDL-2024 LIBRARY; T=293.6K  
Threshold reactions

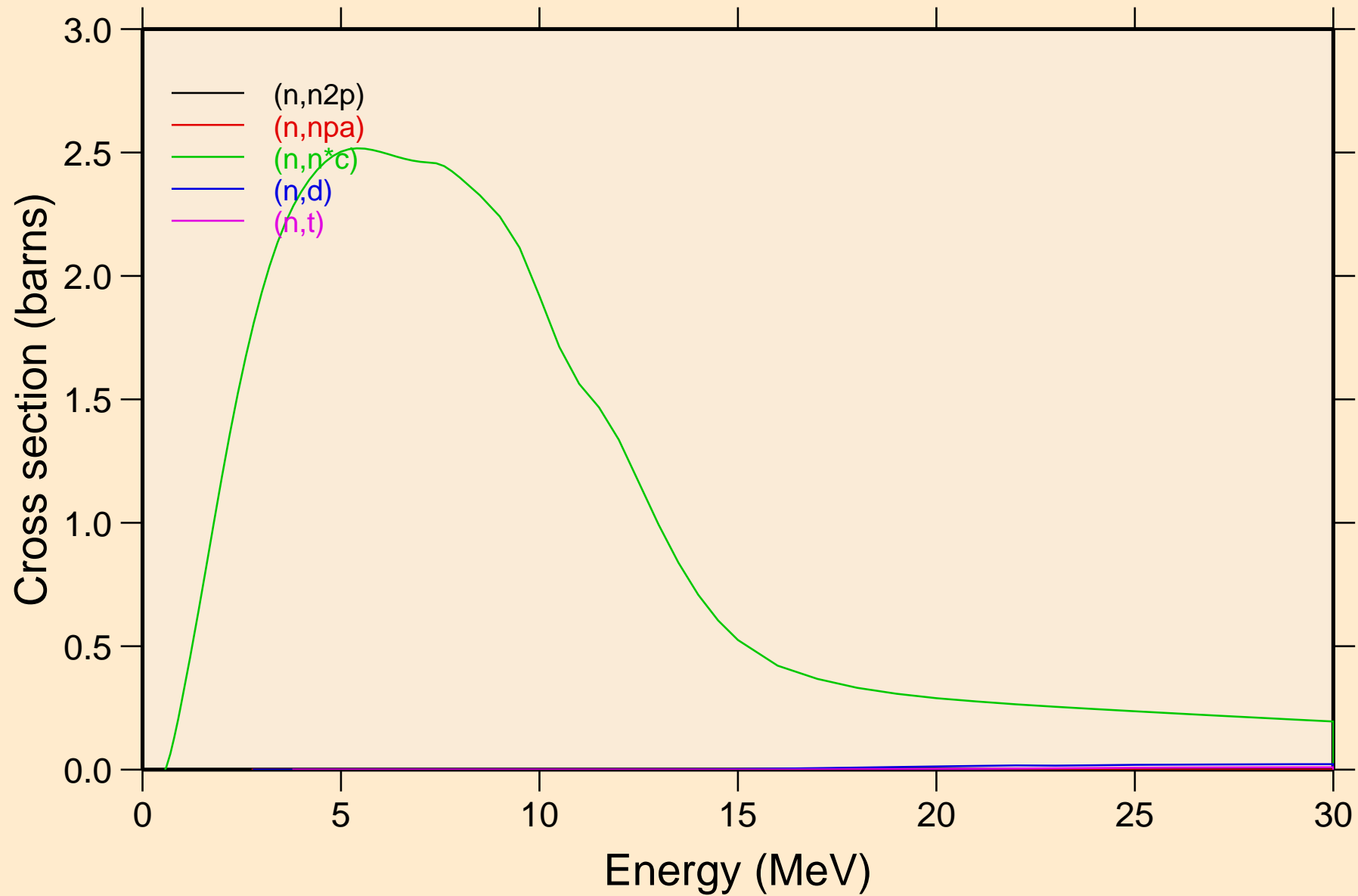

PB199 NEUTRON ACER TENDL-2024 LIBRARY; T=293.6K  
Threshold reactions

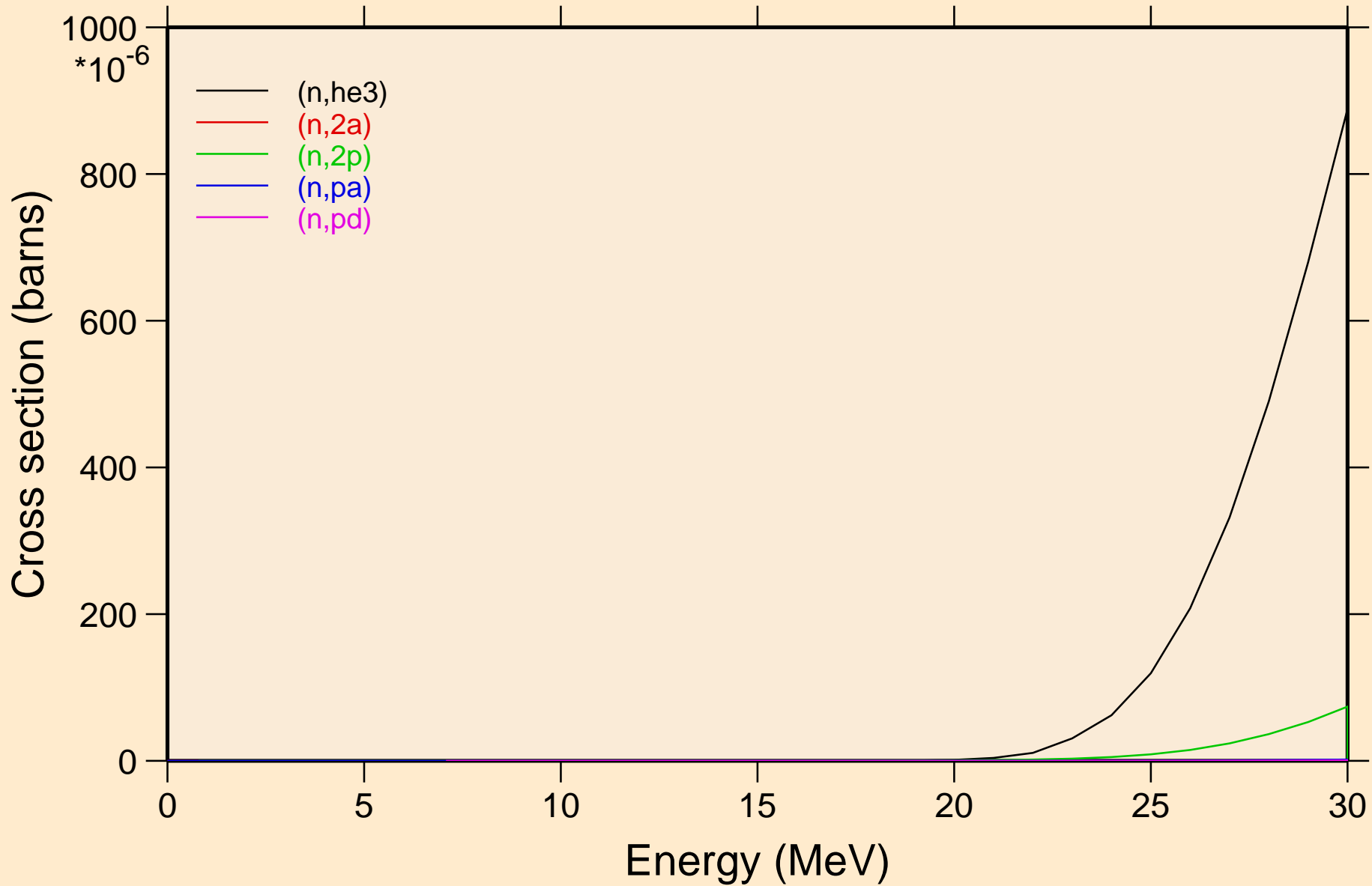

PB199 NEUTRON ACER TENDL-2024 LIBRARY; T=293.6K  
Threshold reactions

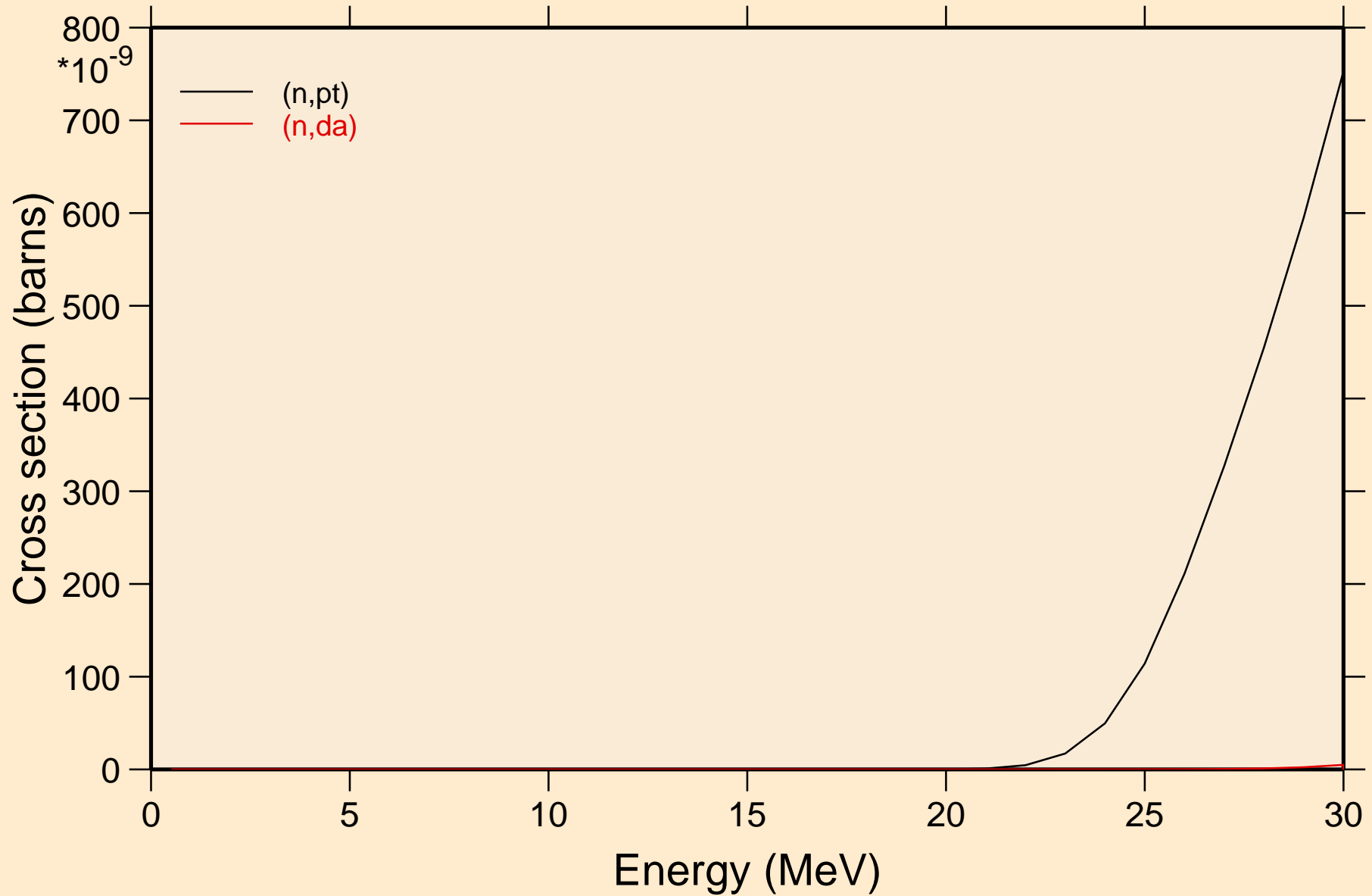

PB199 NEUTRON ACER TENDL-2024 LIBRARY; T=293.6K  
Threshold reactions

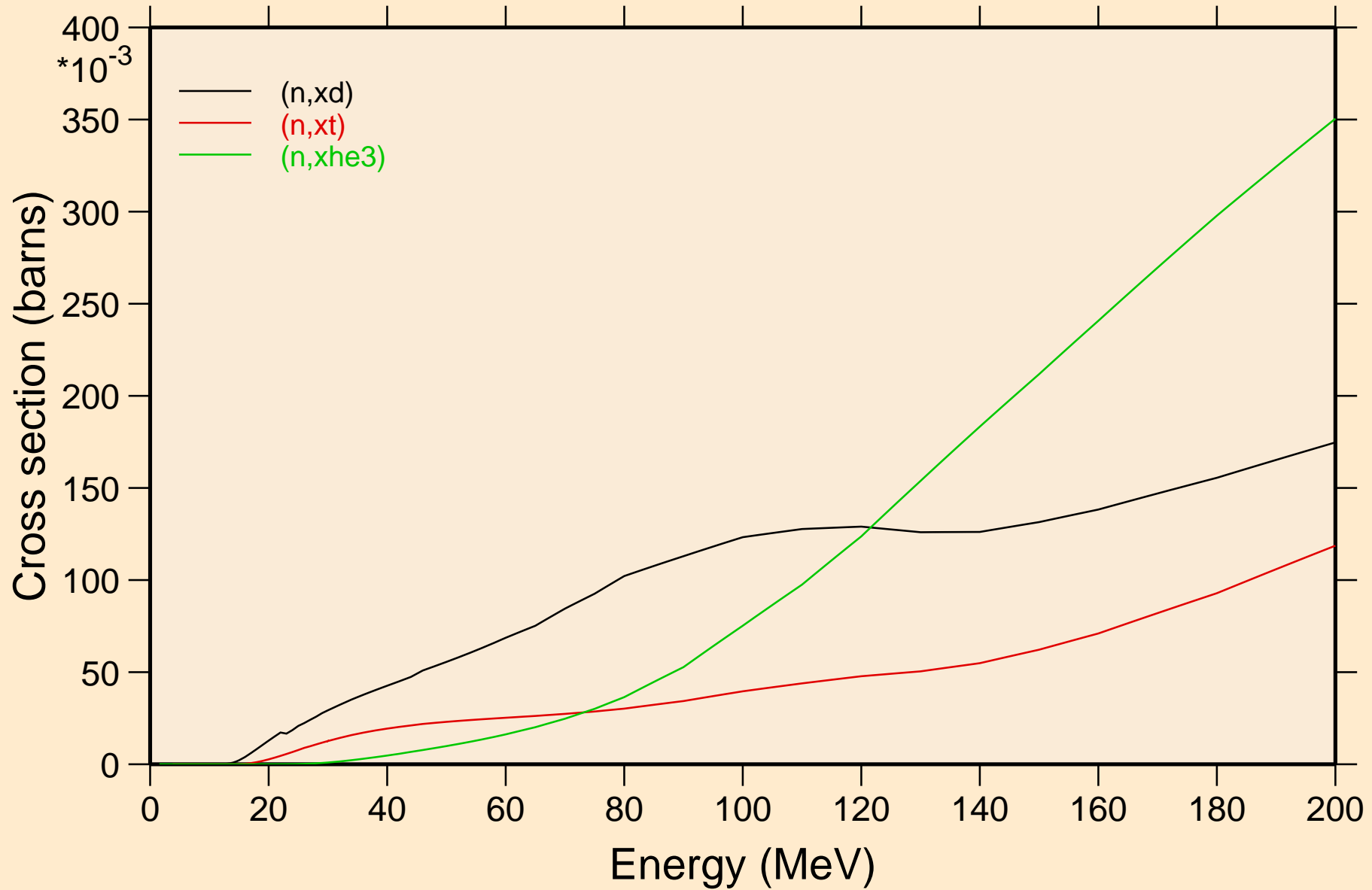

PB199 NEUTRON ACER TENDL-2024 LIBRARY; T=293.6K  
angular distribution for elastic

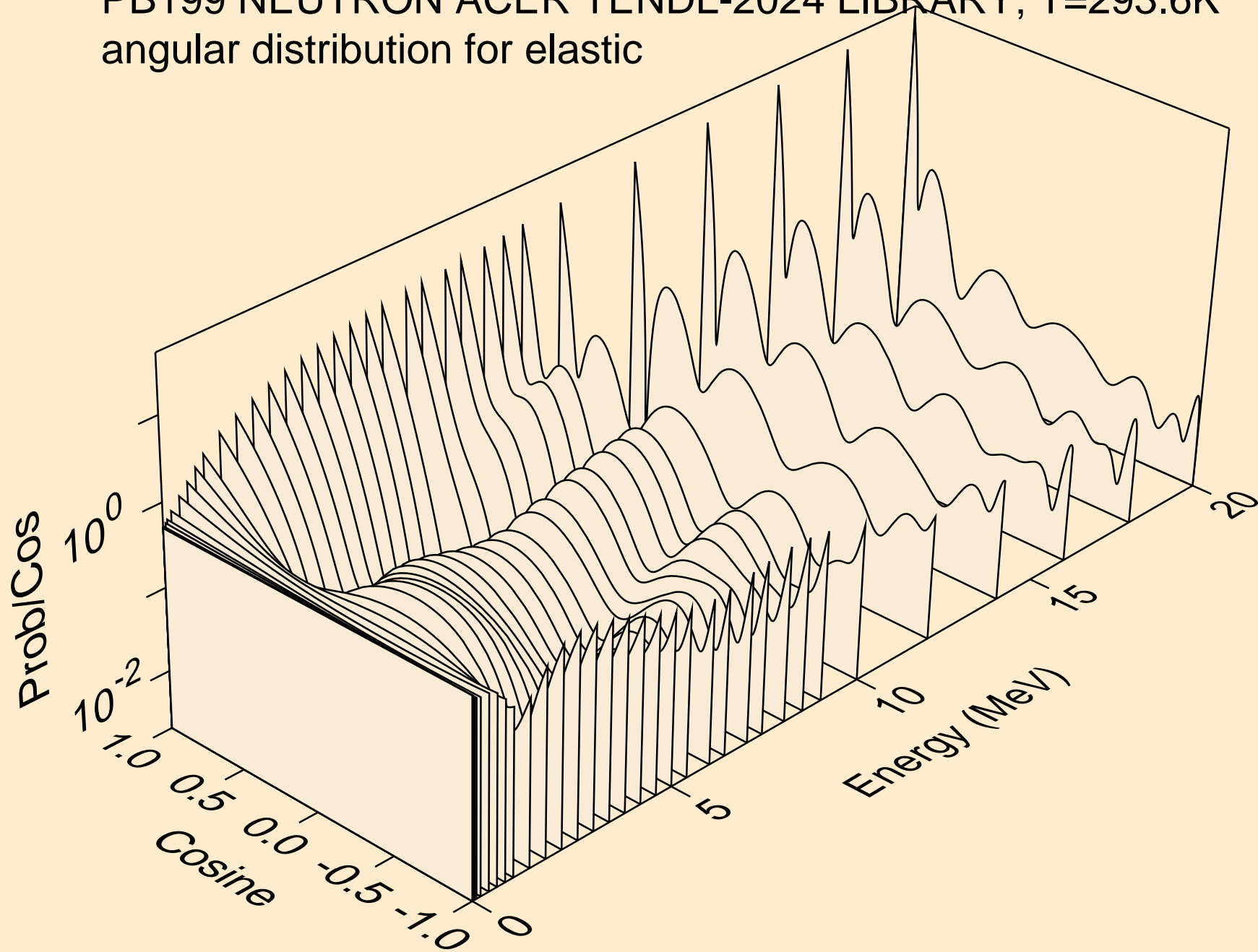

PB199 NEUTRON ACER TENDL-2024 LIBRARY; T=293.6K  
angular distribution for elastic

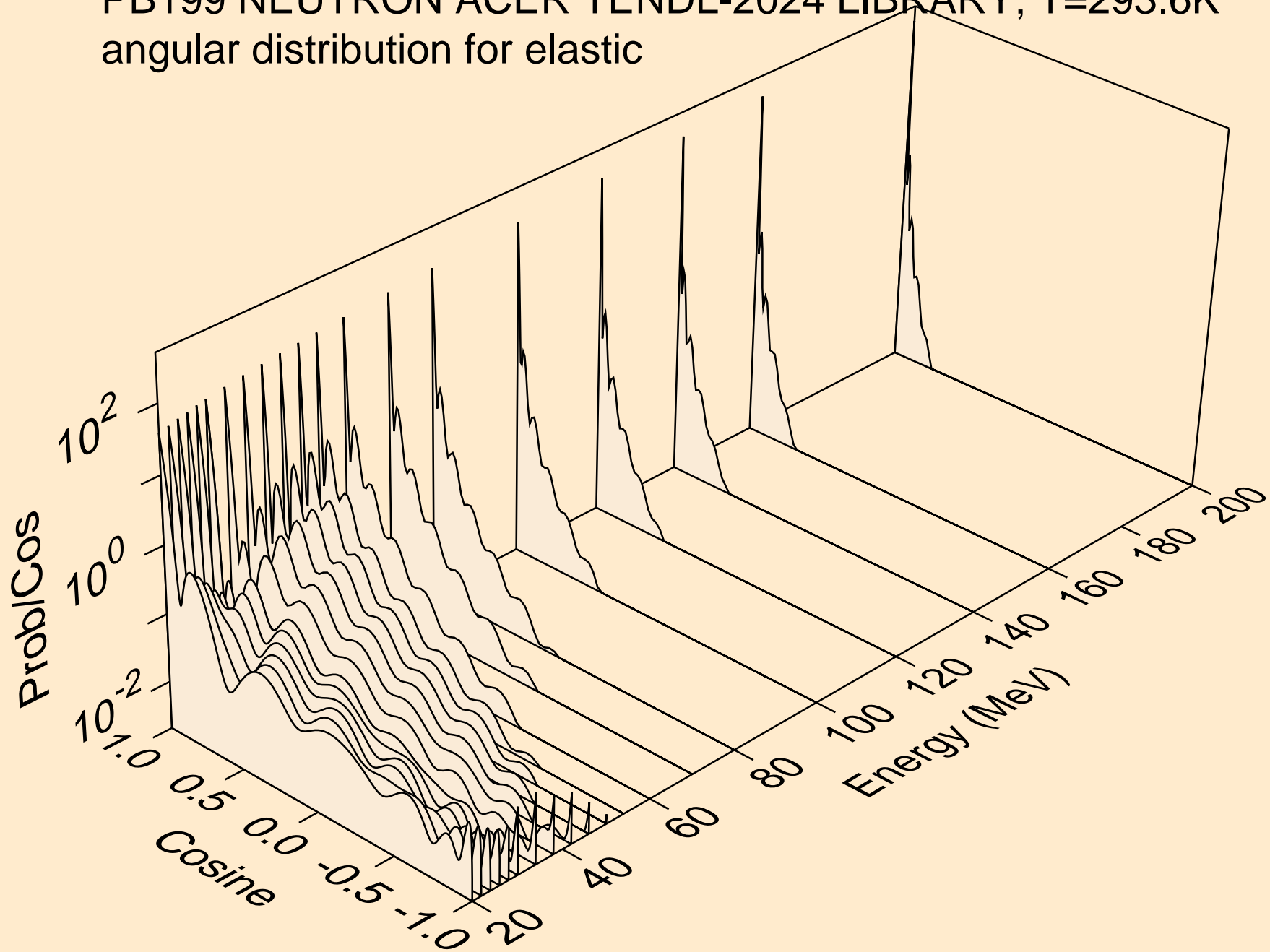

PB199 NEUTRON ACER TENDL-2024 LIBRARY; T=293.6K  
angular distribution for (n,n\*1)

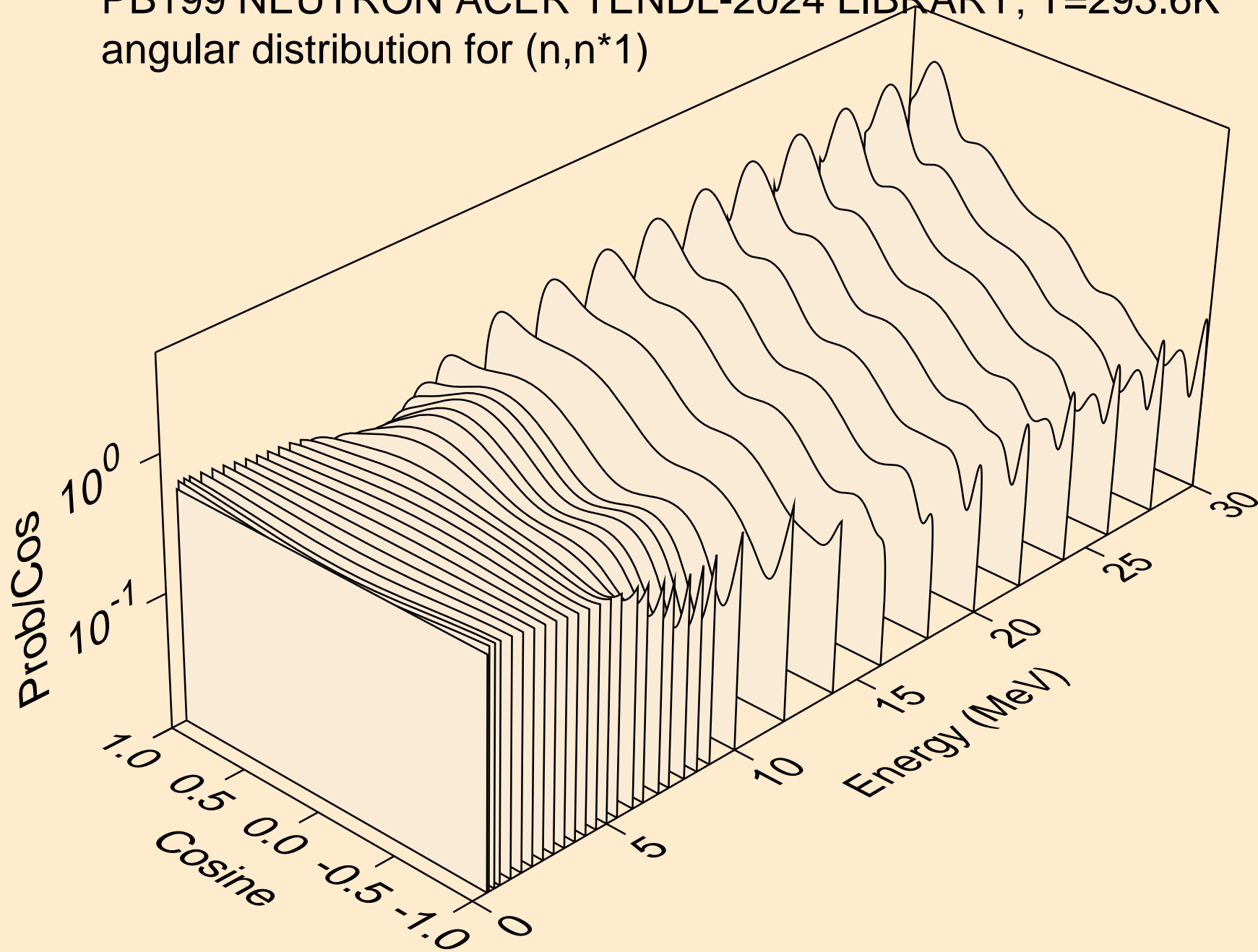

PB199 NEUTRON ACER TENDL-2024 LIBRARY; T=293.6K  
angular distribution for (n,n\*2)

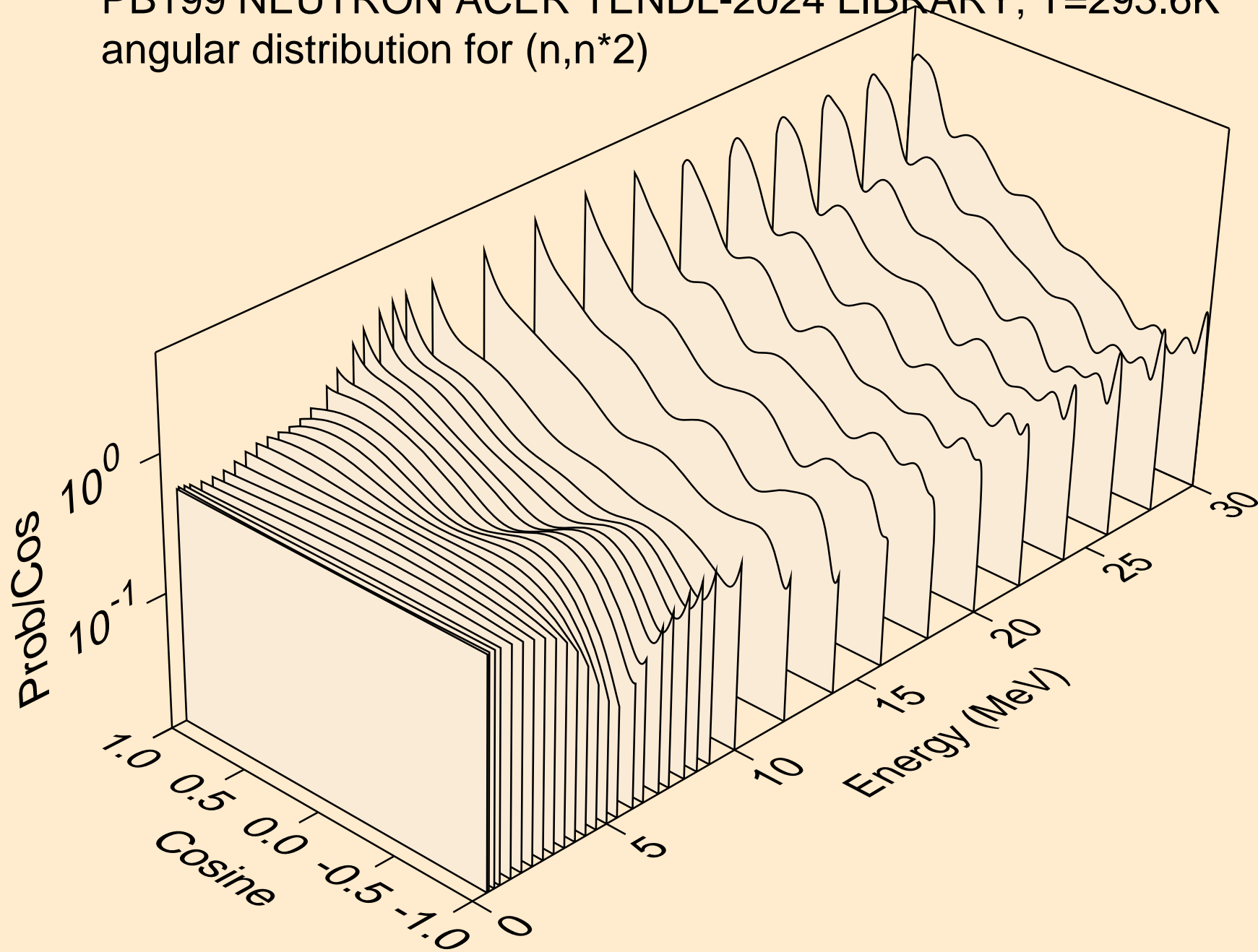

PB199 NEUTRON ACER TENDL-2024 LIBRARY; T=293.6K  
angular distribution for (n,n\*3)

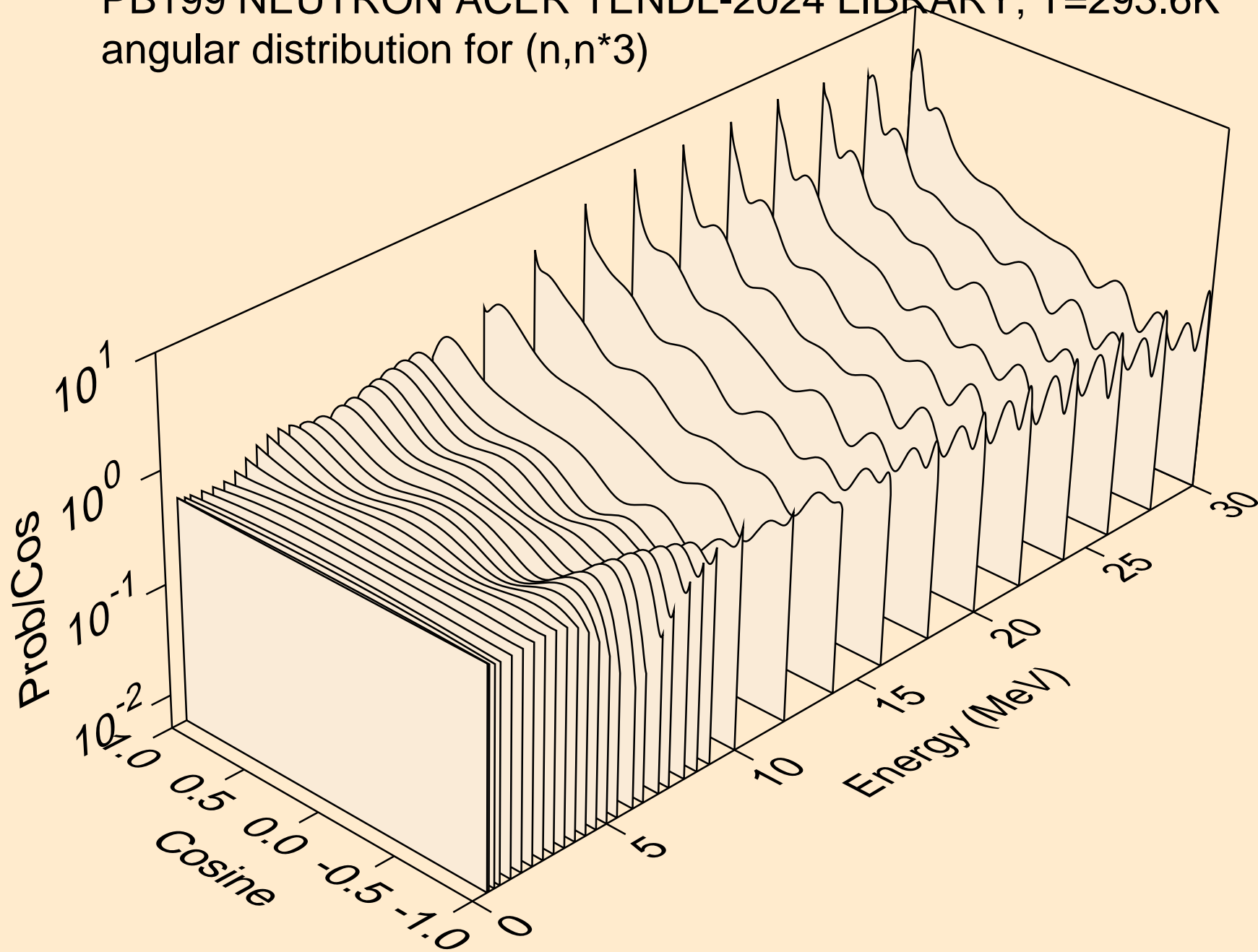

PB199 NEUTRON ACER TENDL-2024 LIBRARY; T=293.6K  
angular distribution for (n,n\*4)

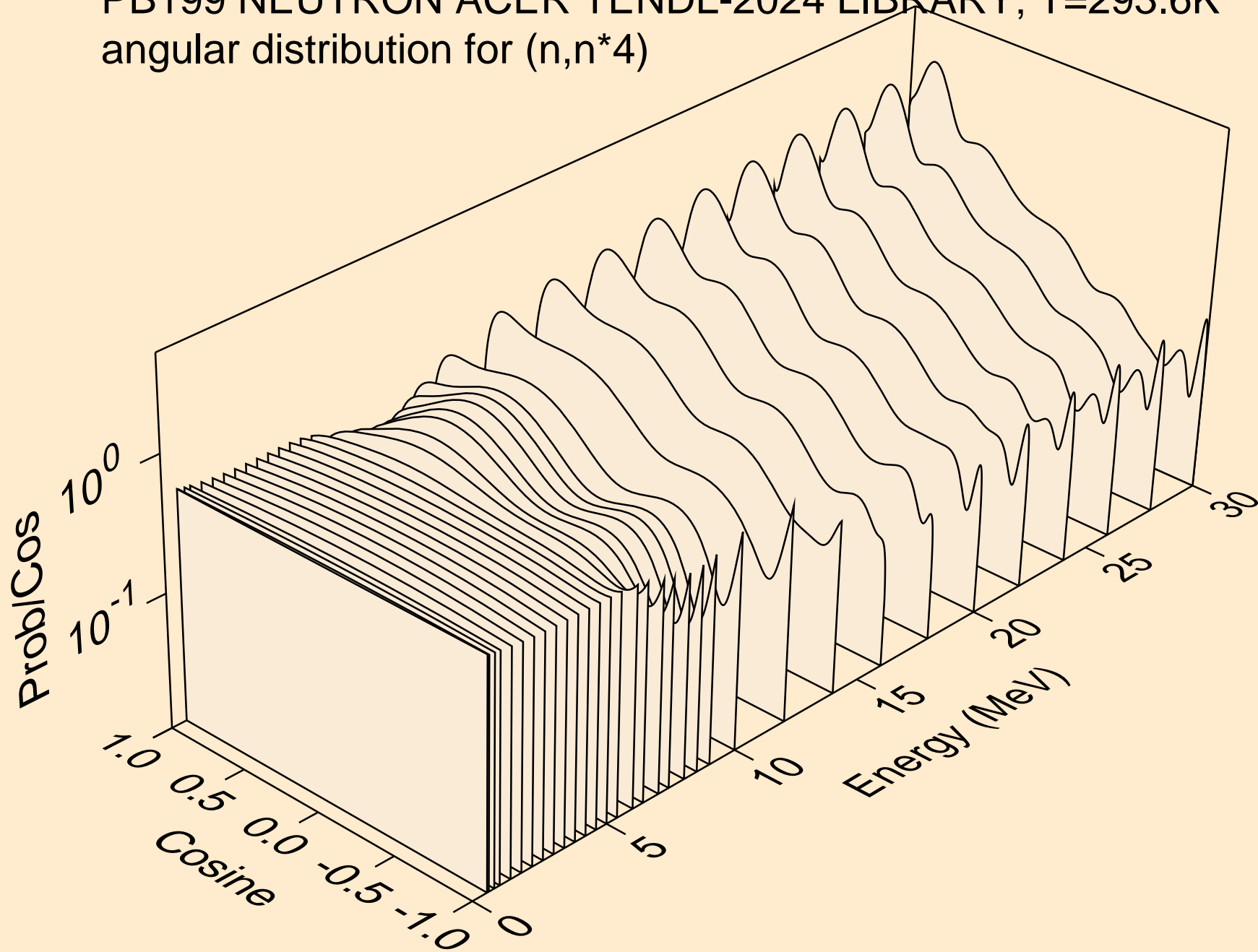

PB199 NEUTRON ACER TENDL-2024 LIBRARY; T=293.6K  
angular distribution for (n,n\*5)

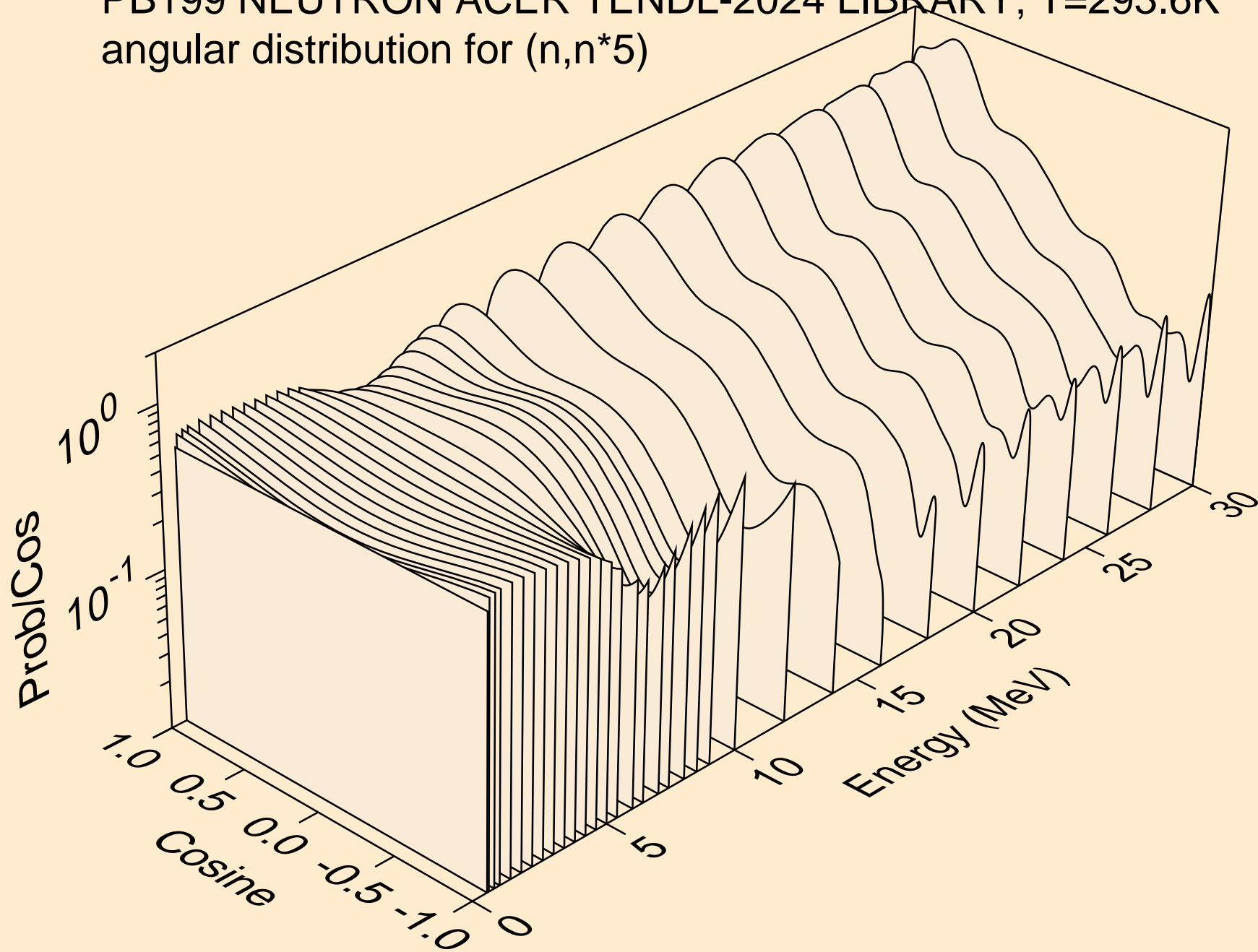

PB199 NEUTRON ACER TENDL-2024 LIBRARY; T=293.6K  
angular distribution for (n,n\*6)

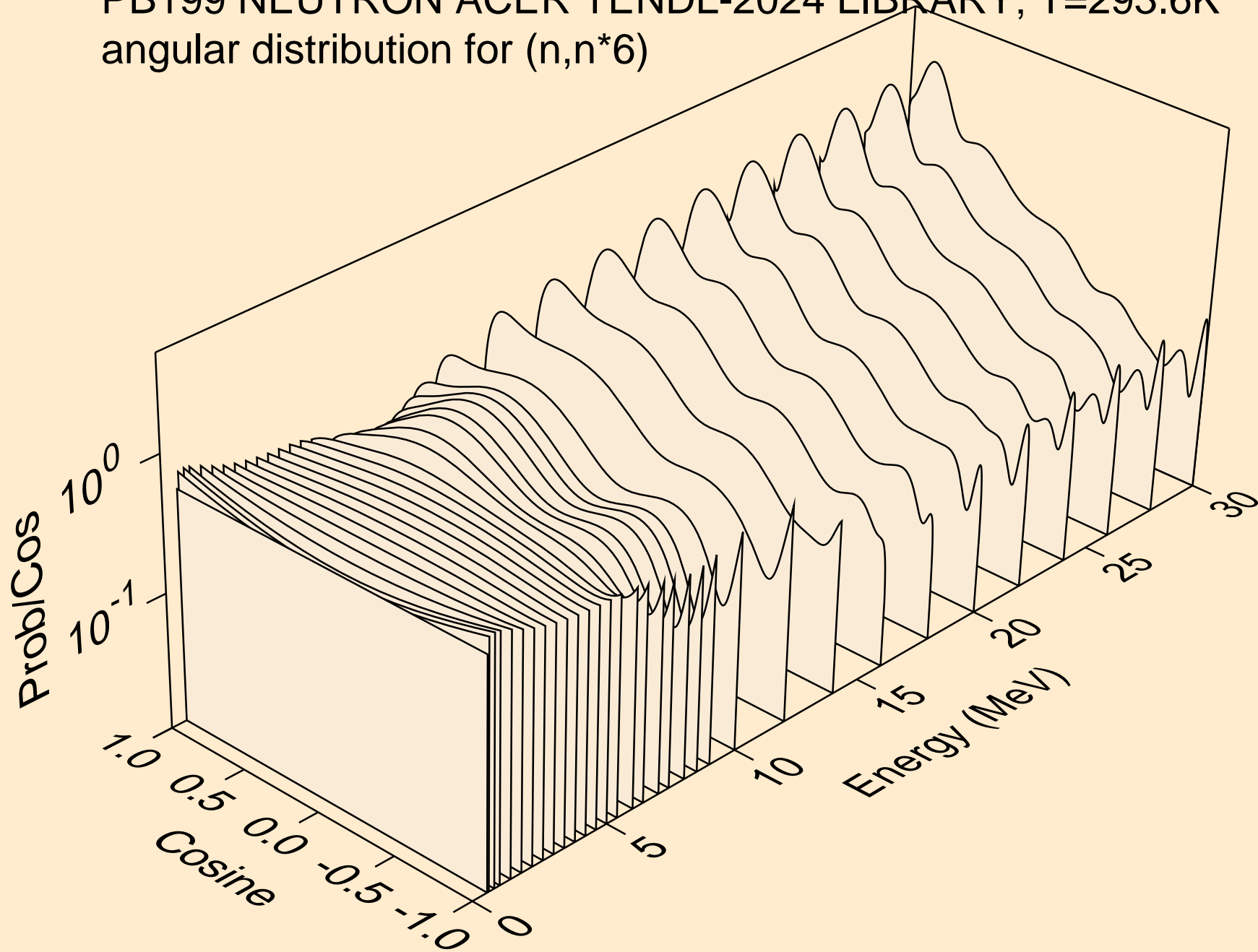

PB199 NEUTRON ACER TENDL-2024 LIBRARY; T=293.6K  
angular distribution for (n,n\*7)

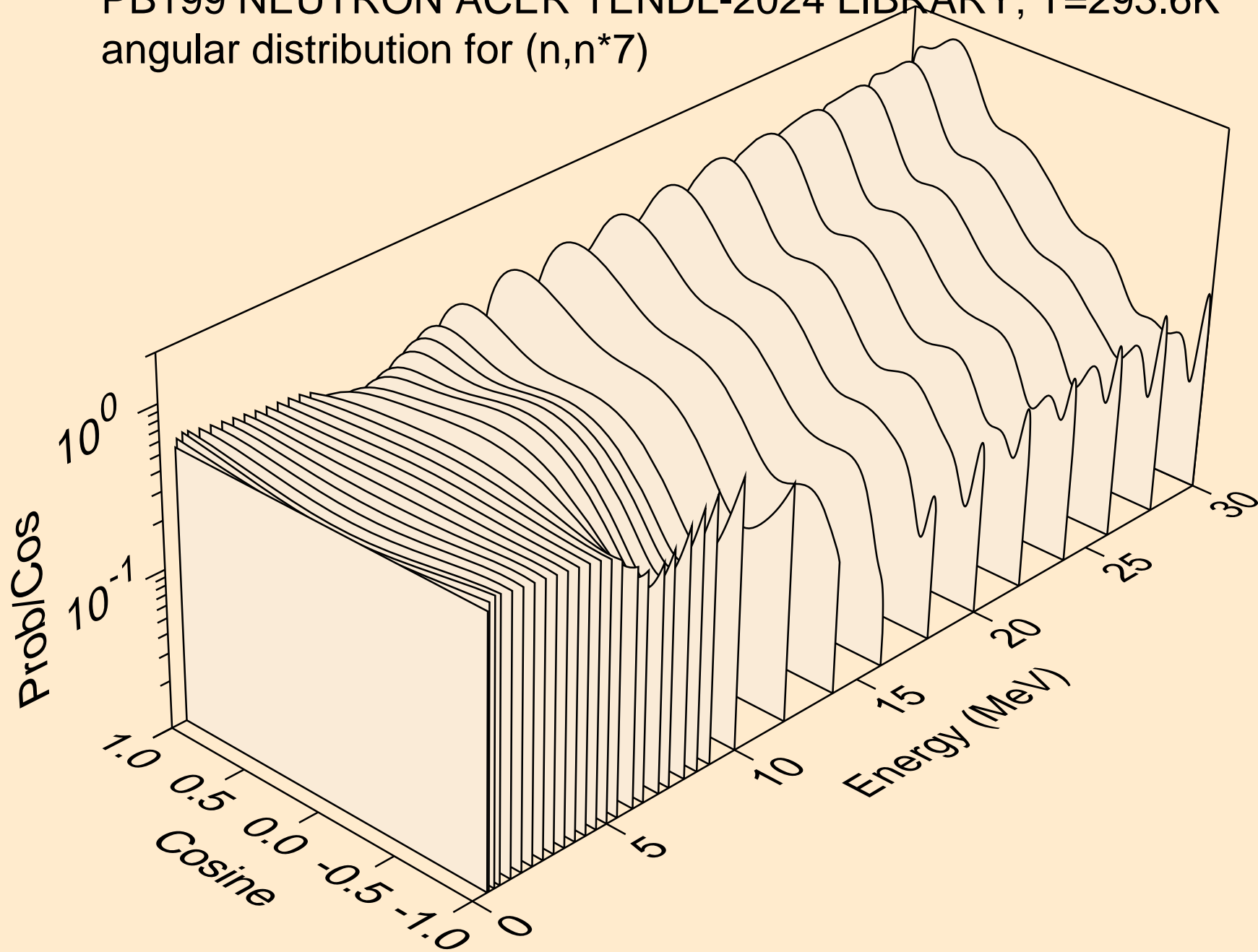

PB199 NEUTRON ACER TENDL-2024 LIBRARY; T=293.6K  
angular distribution for (n,n\*8)

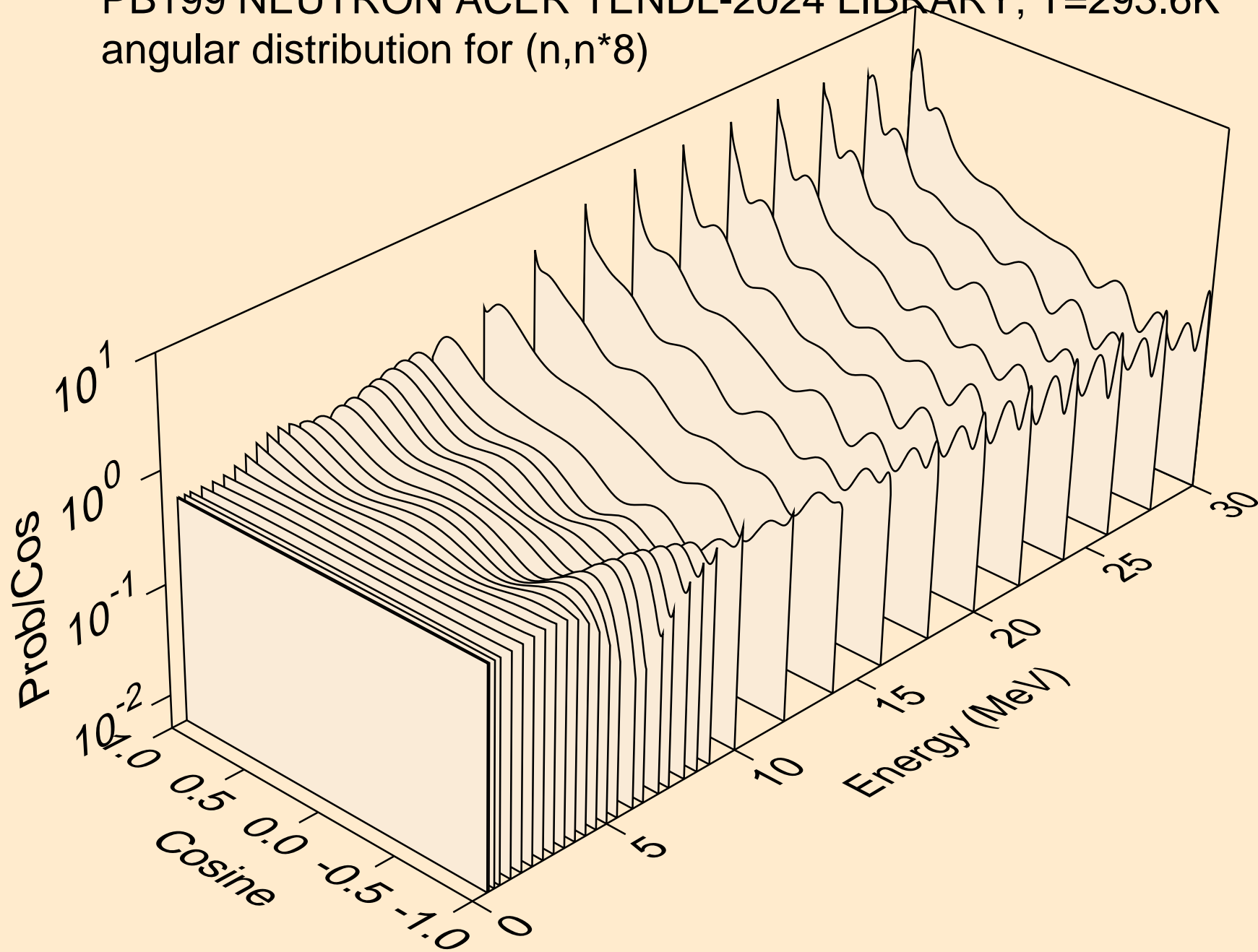

PB199 NEUTRON ACER TENDL-2024 LIBRARY; T=293.6K  
angular distribution for (n,n\*9)

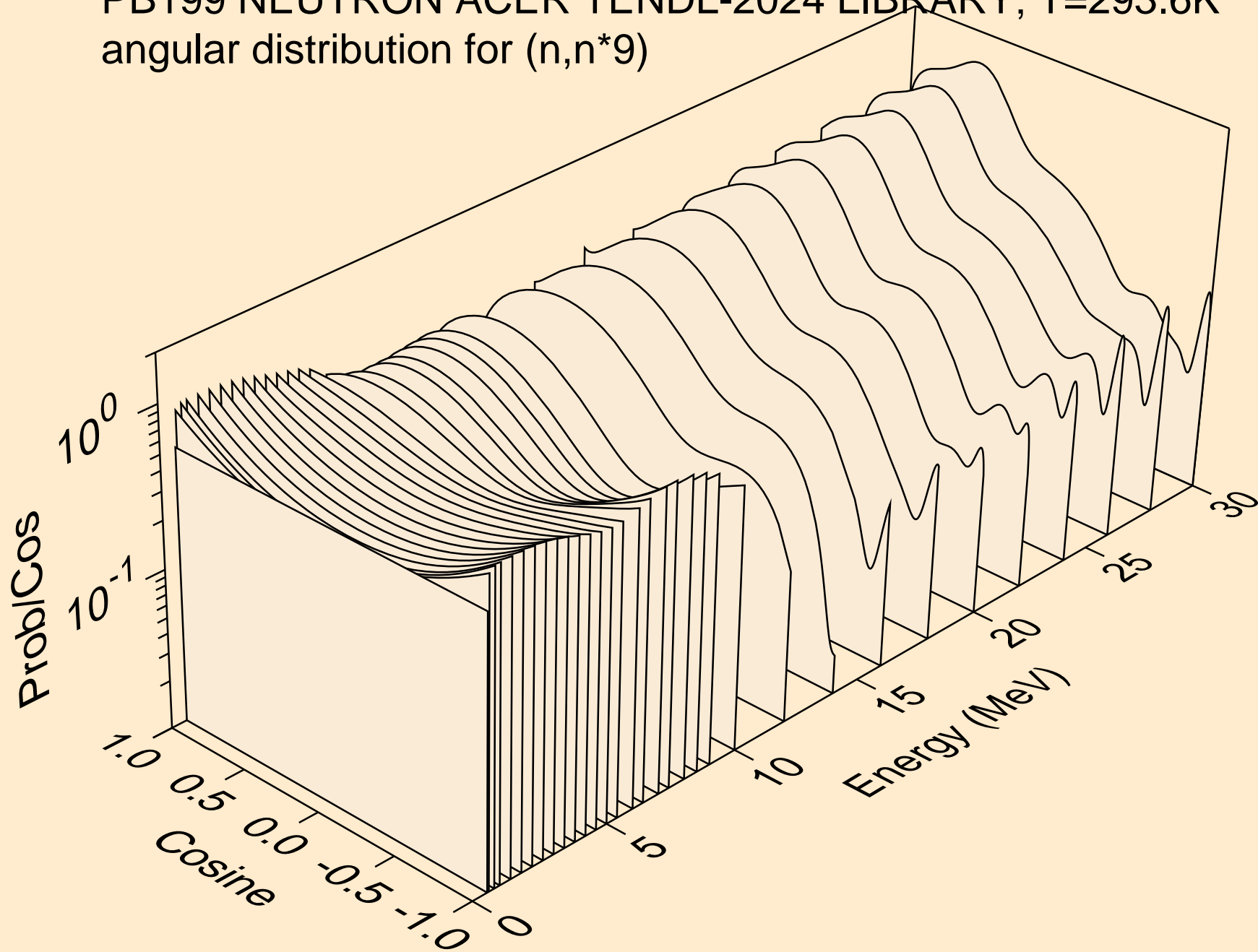

PB199 NEUTRON ACER TENDL-2024 LIBRARY; T=293.6K  
angular distribution for (n,n\*10)

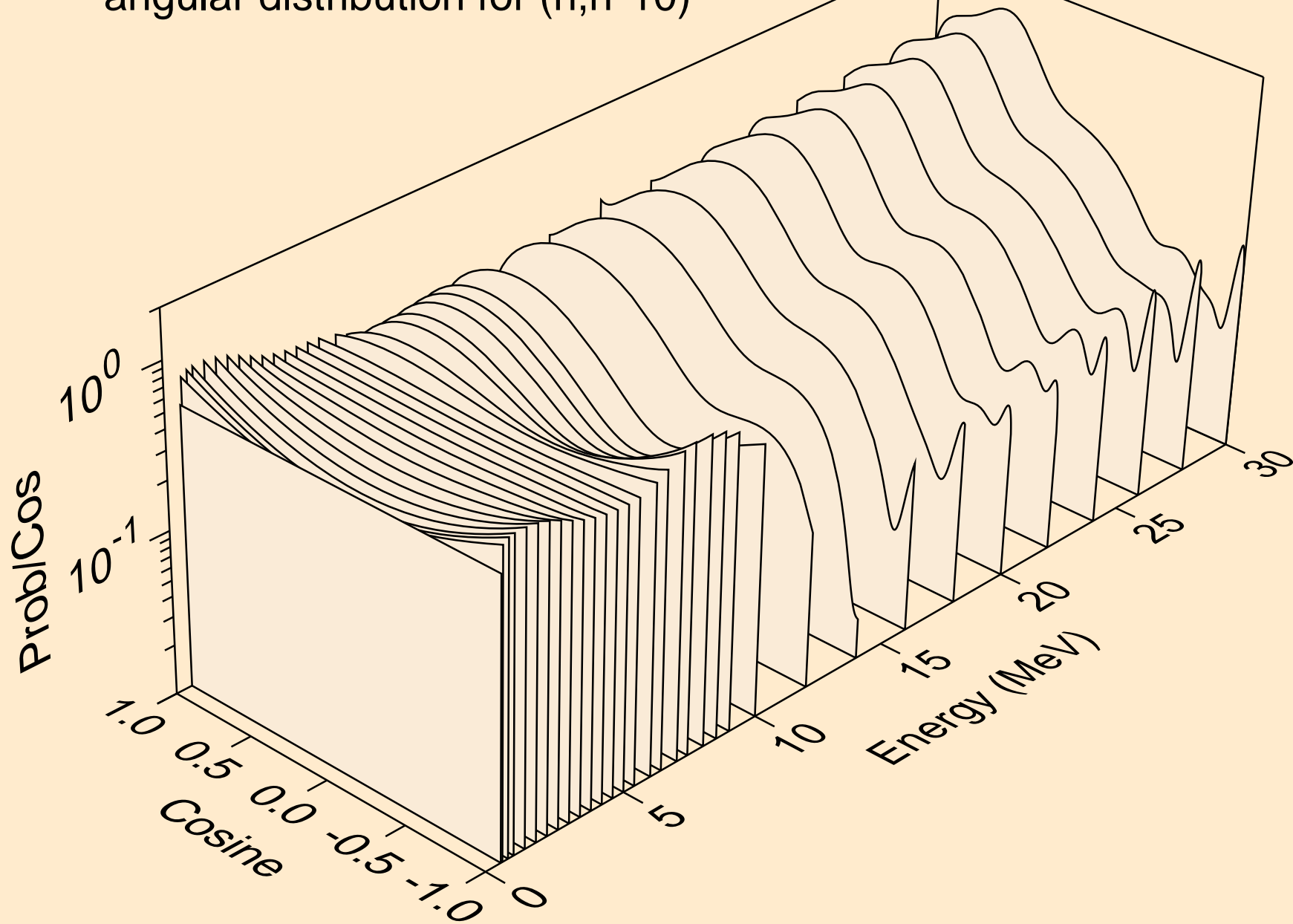

PB199 NEUTRON ACER TENDL-2024 LIBRARY; T=293.6K  
angular distribution for (n,n\*11)

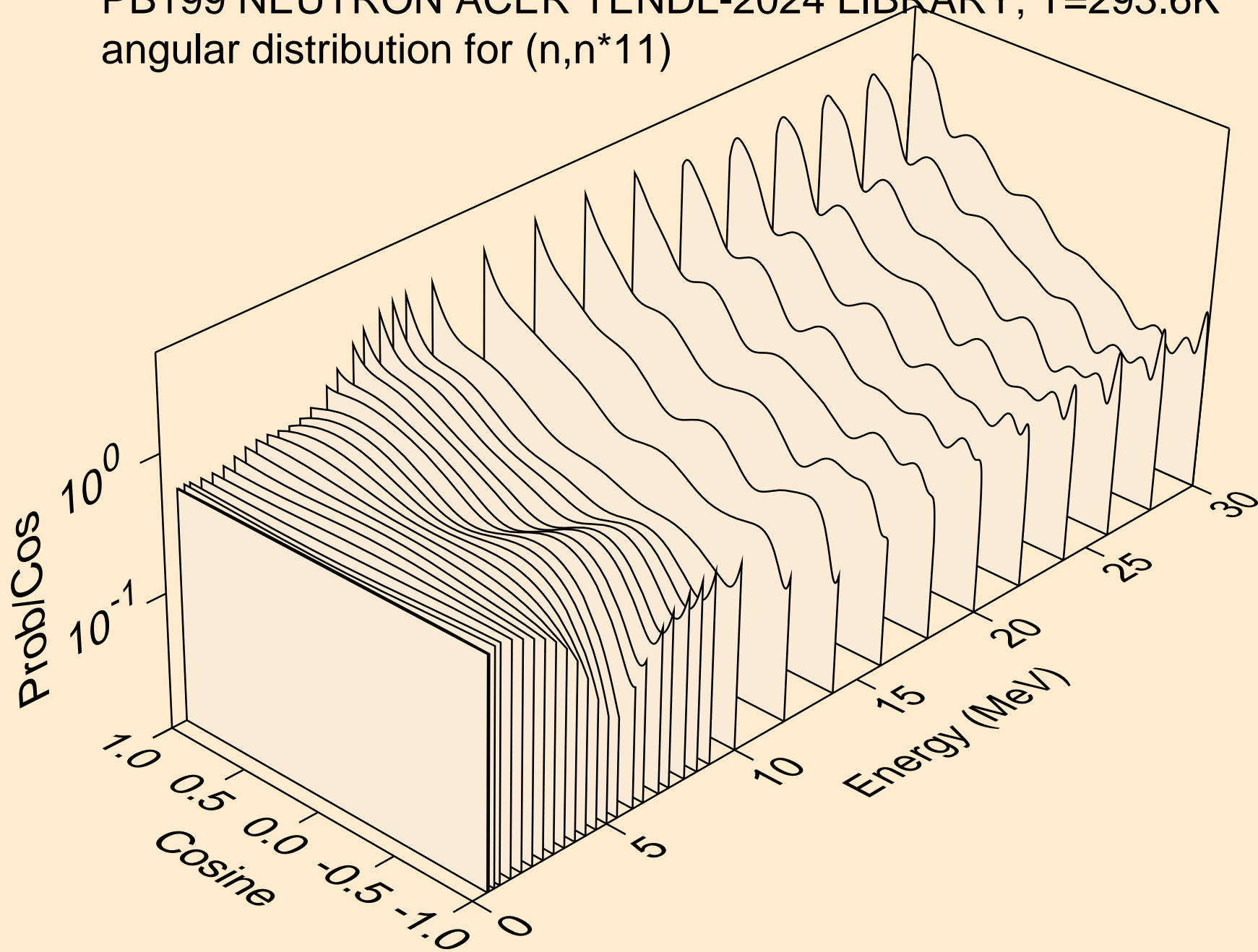

PB199 NEUTRON ACER TENDL-2024 LIBRARY; T=293.6K  
angular distribution for (n,n\*12)

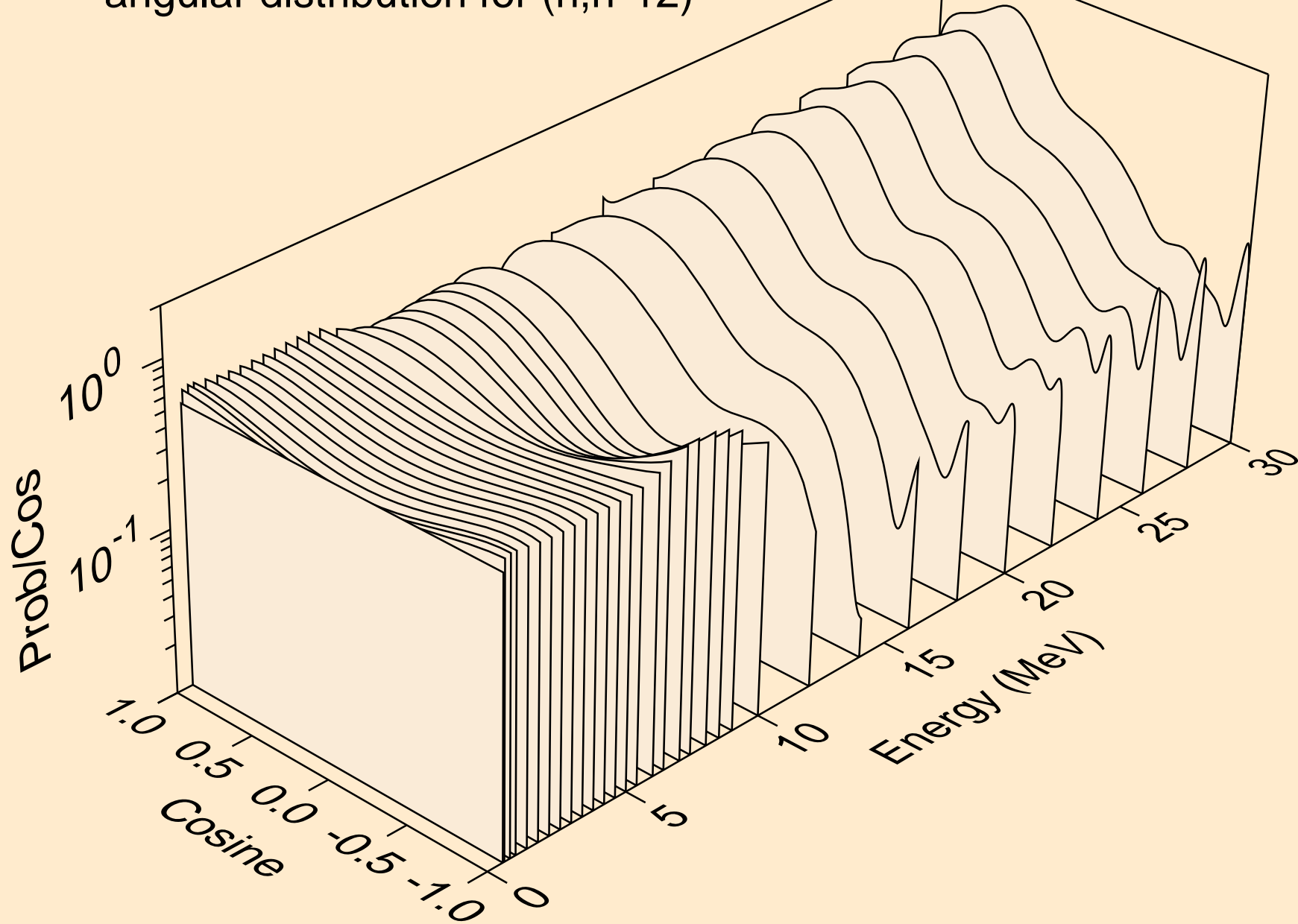

PB199 NEUTRON ACER TENDL-2024 LIBRARY; T=293.6K  
angular distribution for (n,n\*13)

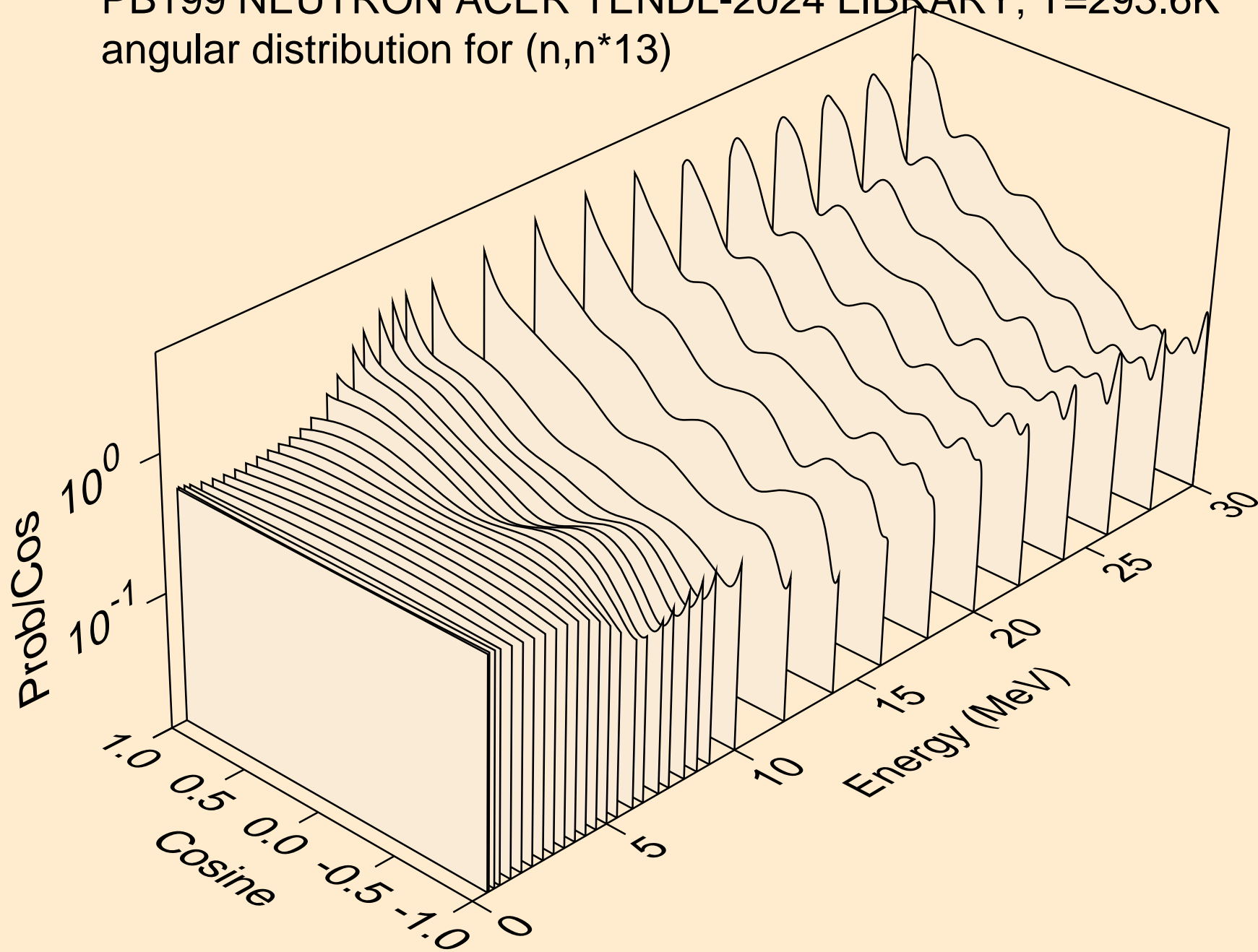

PB199 NEUTRON ACER TENDL-2024 LIBRARY; T=293.6K  
angular distribution for (n,n\*14)

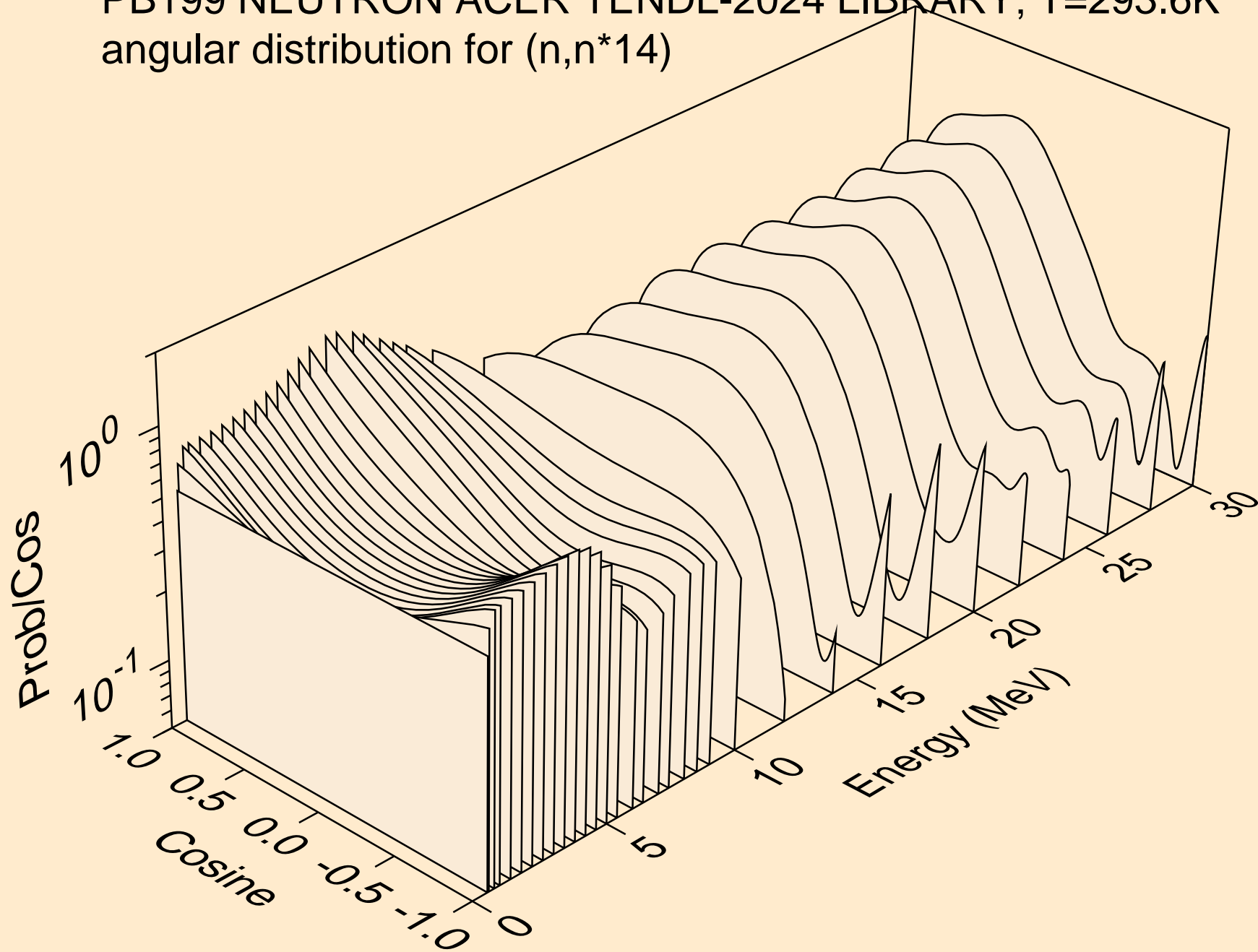

PB199 NEUTRON ACER TENDL-2024 LIBRARY; T=293.6K  
angular distribution for (n,n\*15)

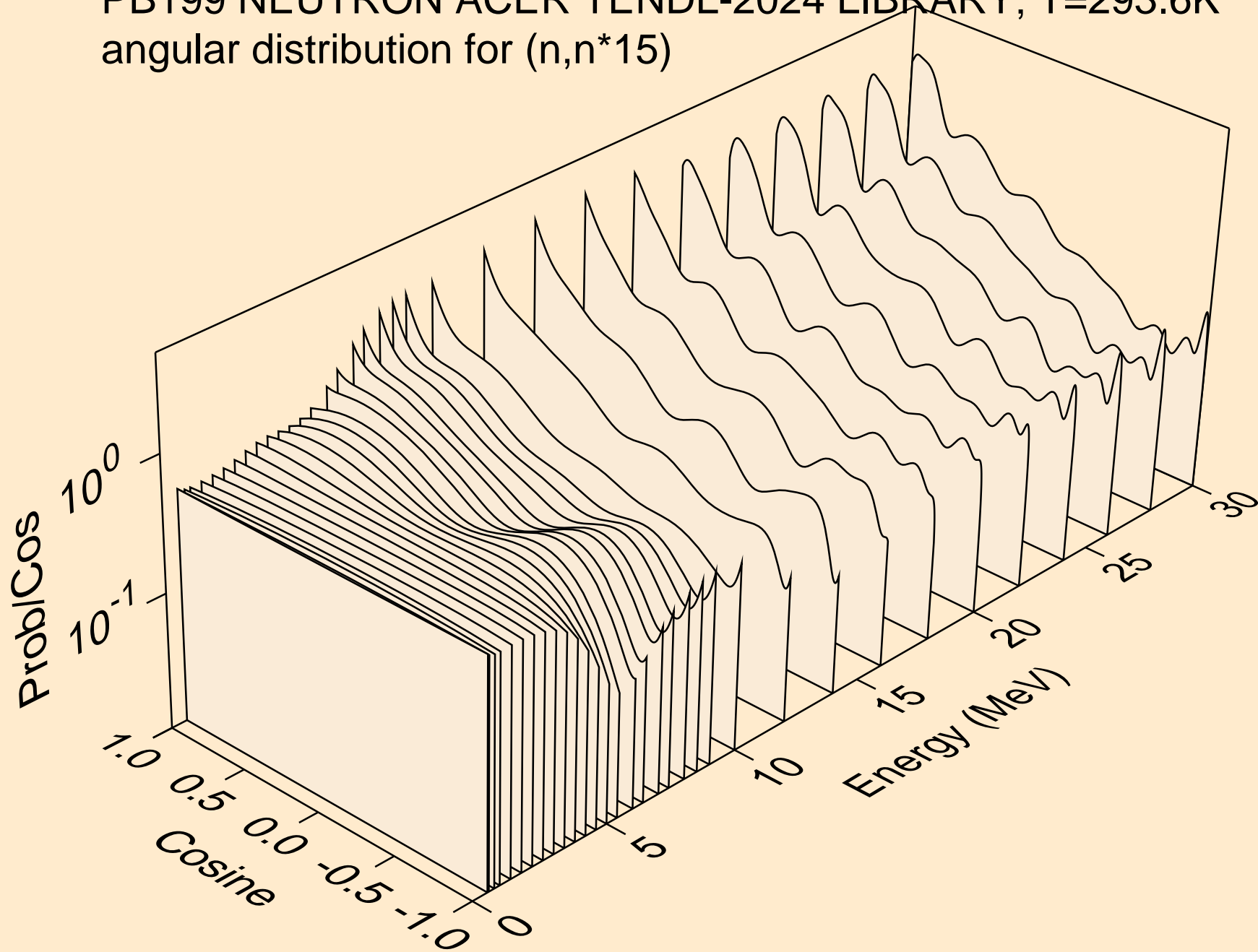

PB199 NEUTRON ACER TENDL-2024 LIBRARY; T=293.6K  
angular distribution for (n,n\*16)

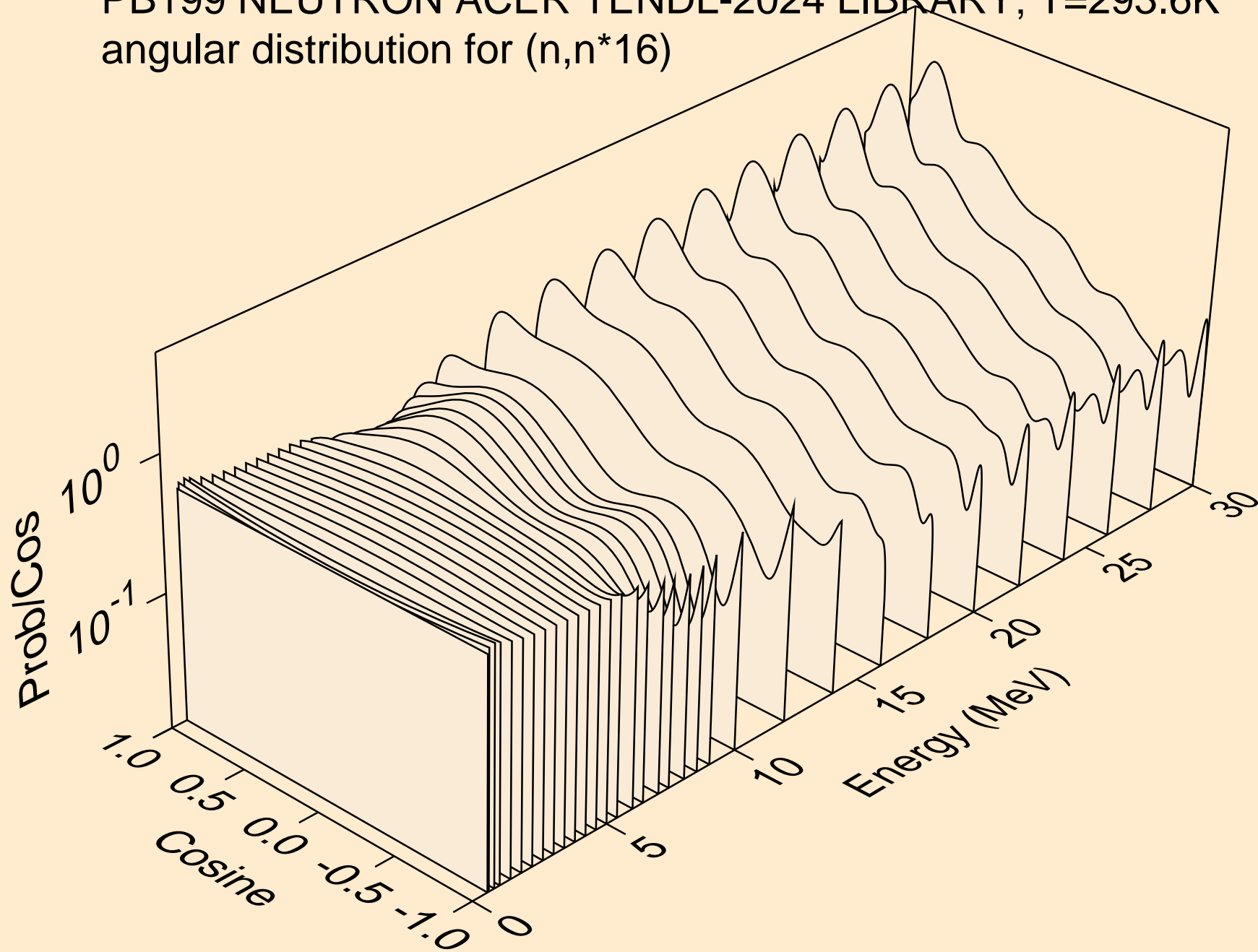

PB199 NEUTRON ACER TENDL-2024 LIBRARY; T=293.6K  
angular distribution for (n,n\*17)

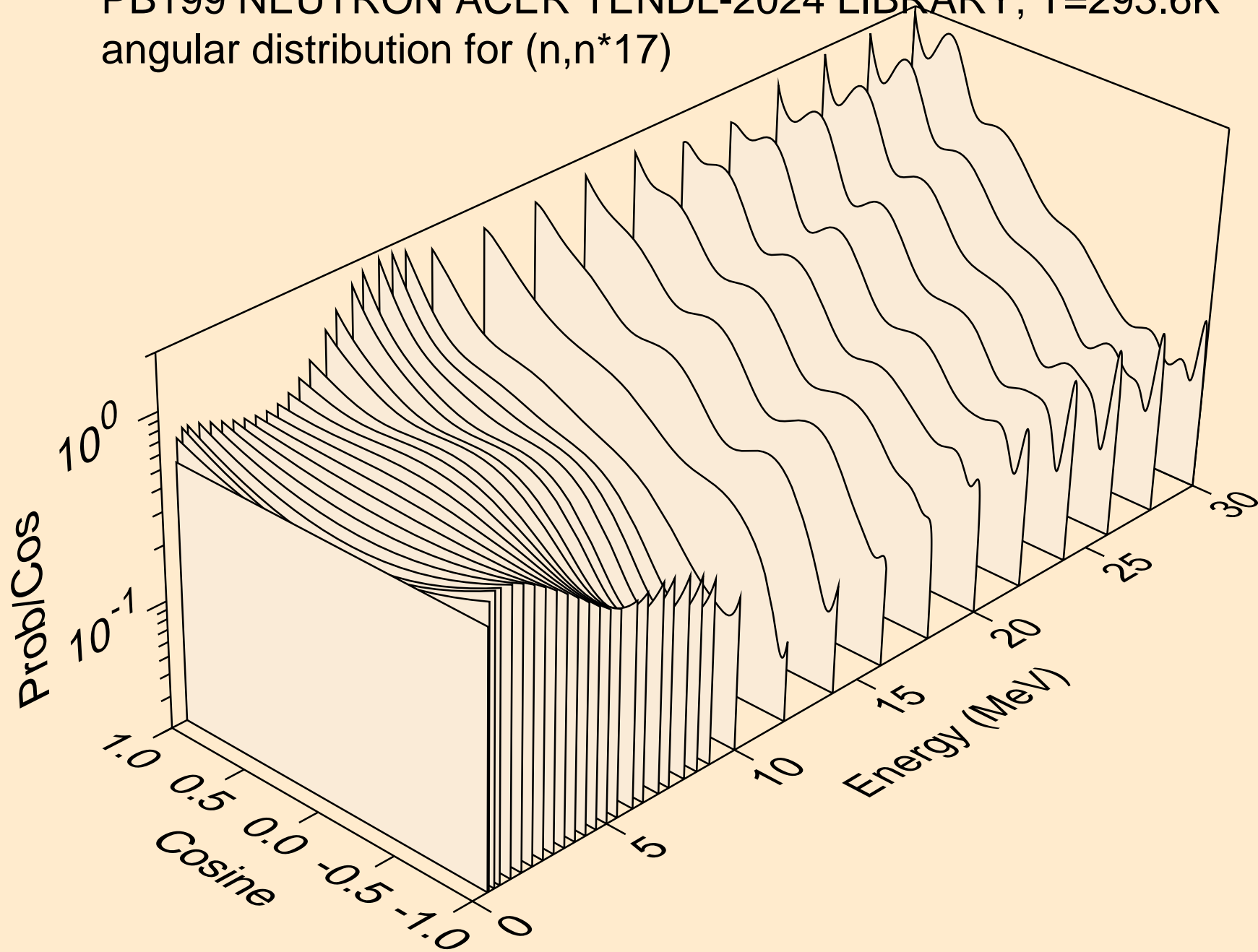

PB199 NEUTRON ACER TENDL-2024 LIBRARY; T=293.6K  
angular distribution for (n,n\*18)

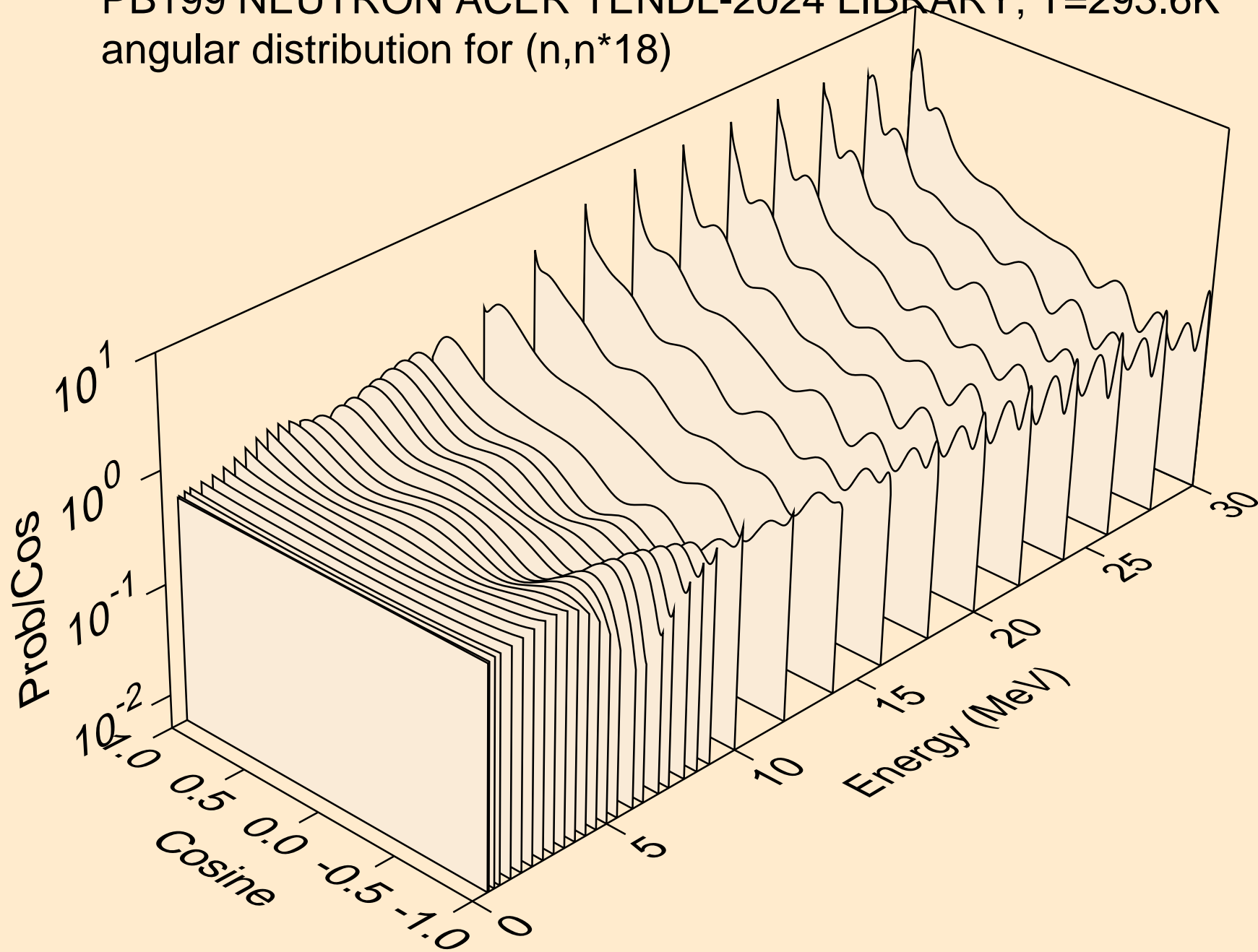

PB199 NEUTRON ACER TENDL-2024 LIBRARY; T=293.6K  
angular distribution for (n,n\*19)

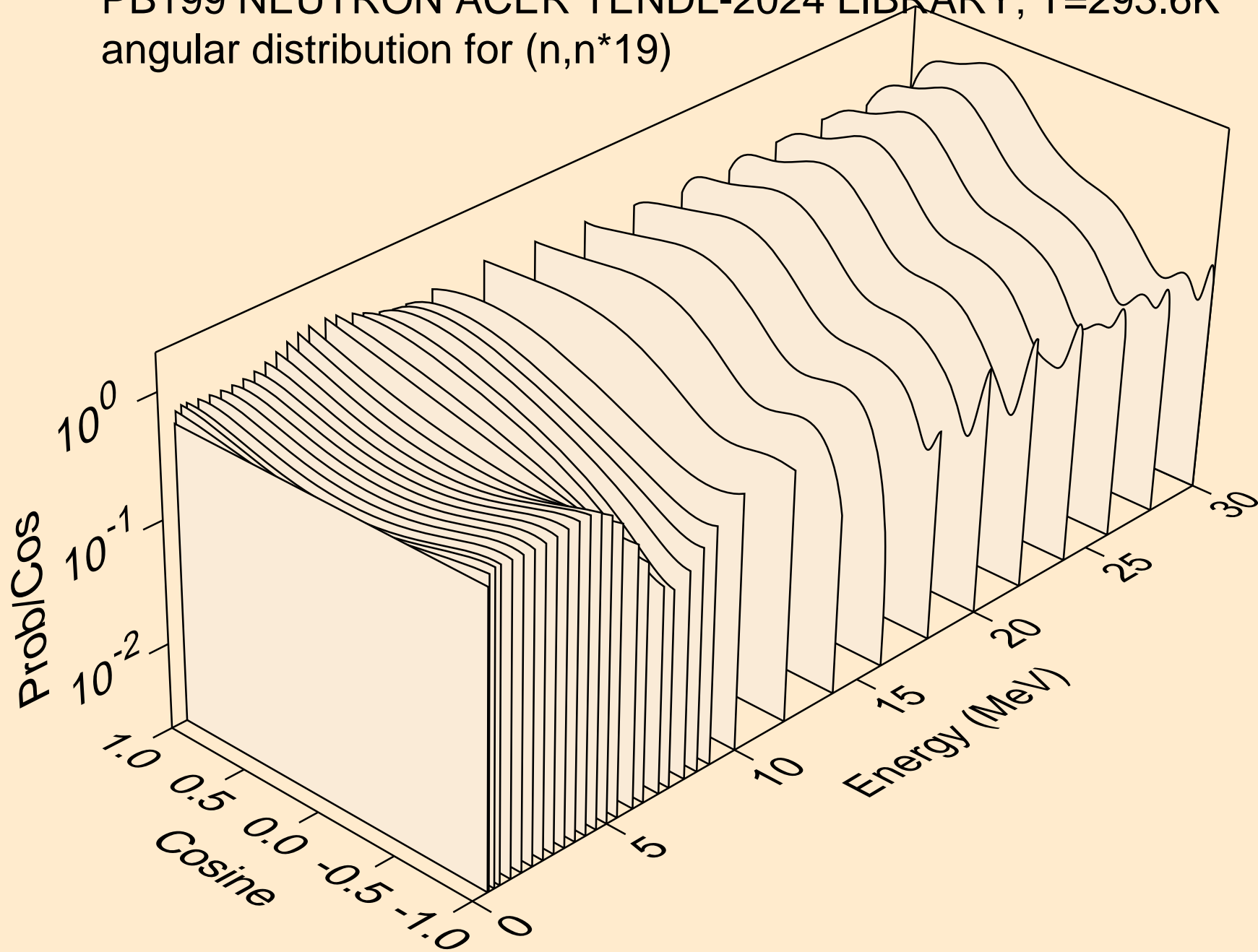

PB199 NEUTRON ACER TENDL-2024 LIBRARY; T=293.6K  
angular distribution for (n,n\*20)

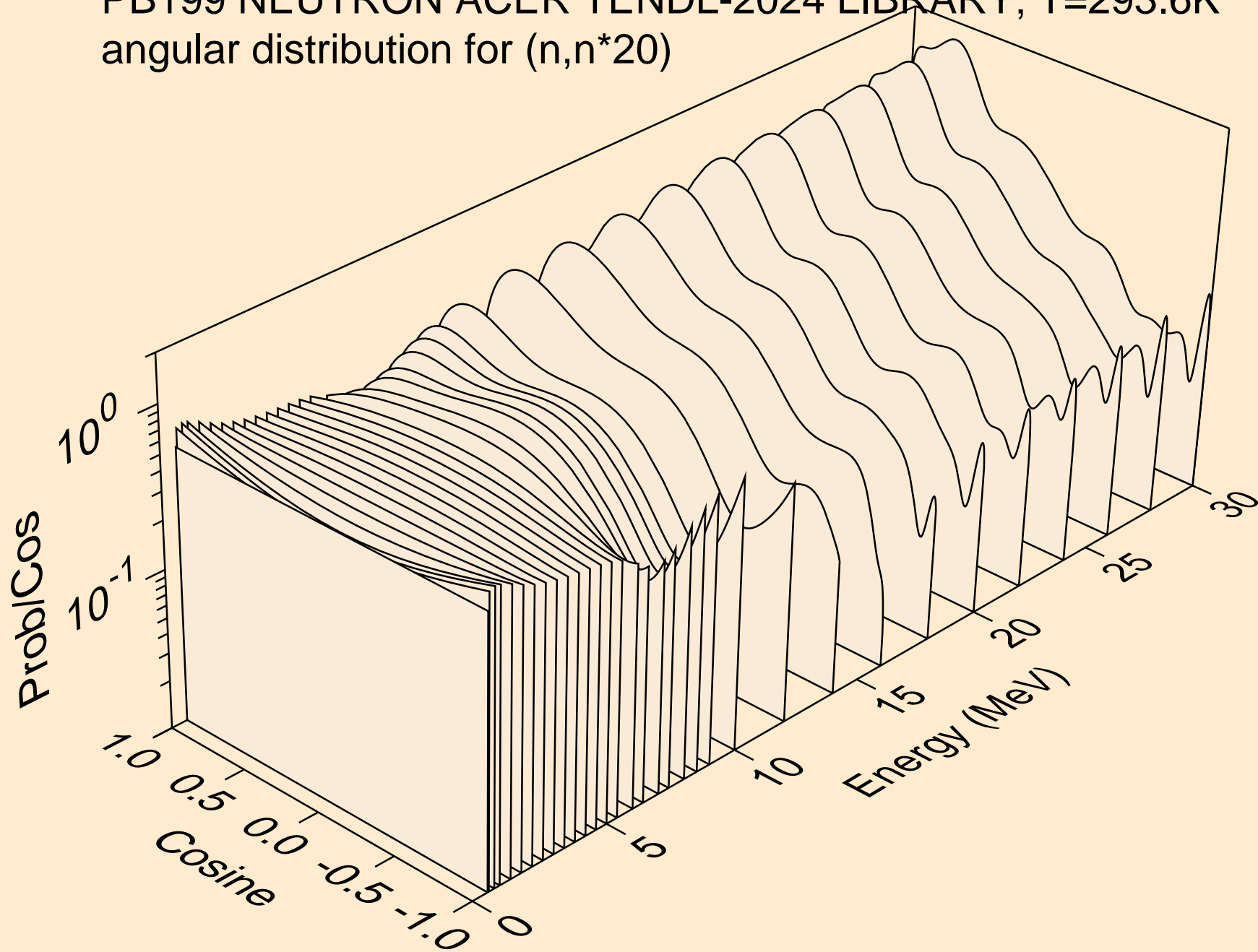

PB199 NEUTRON ACER TENDL-2024 LIBRARY; T=293.6K  
angular distribution for (n,n\*21)

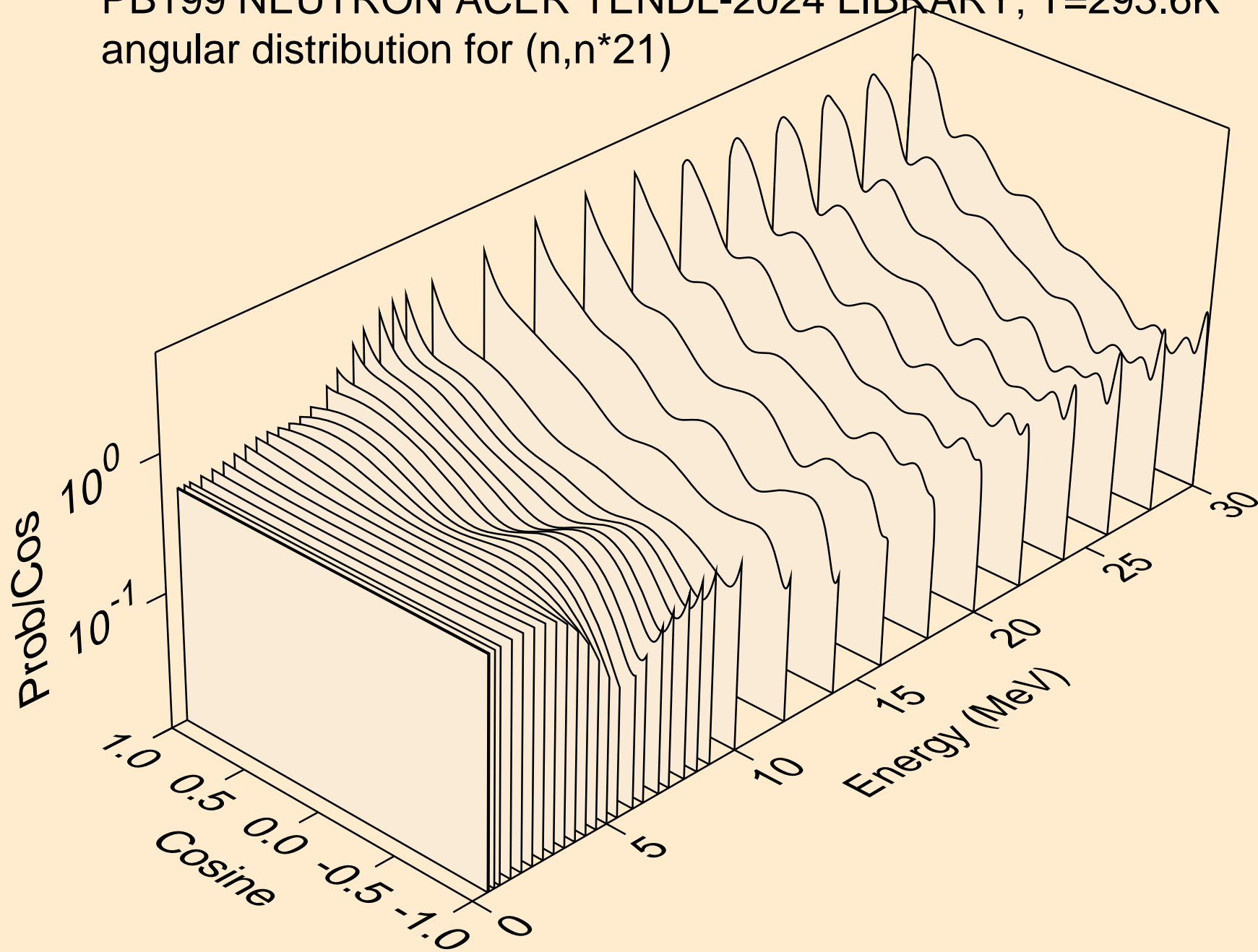

PB199 NEUTRON ACER TENDL-2024 LIBRARY; T=293.6K  
angular distribution for (n,n\*22)

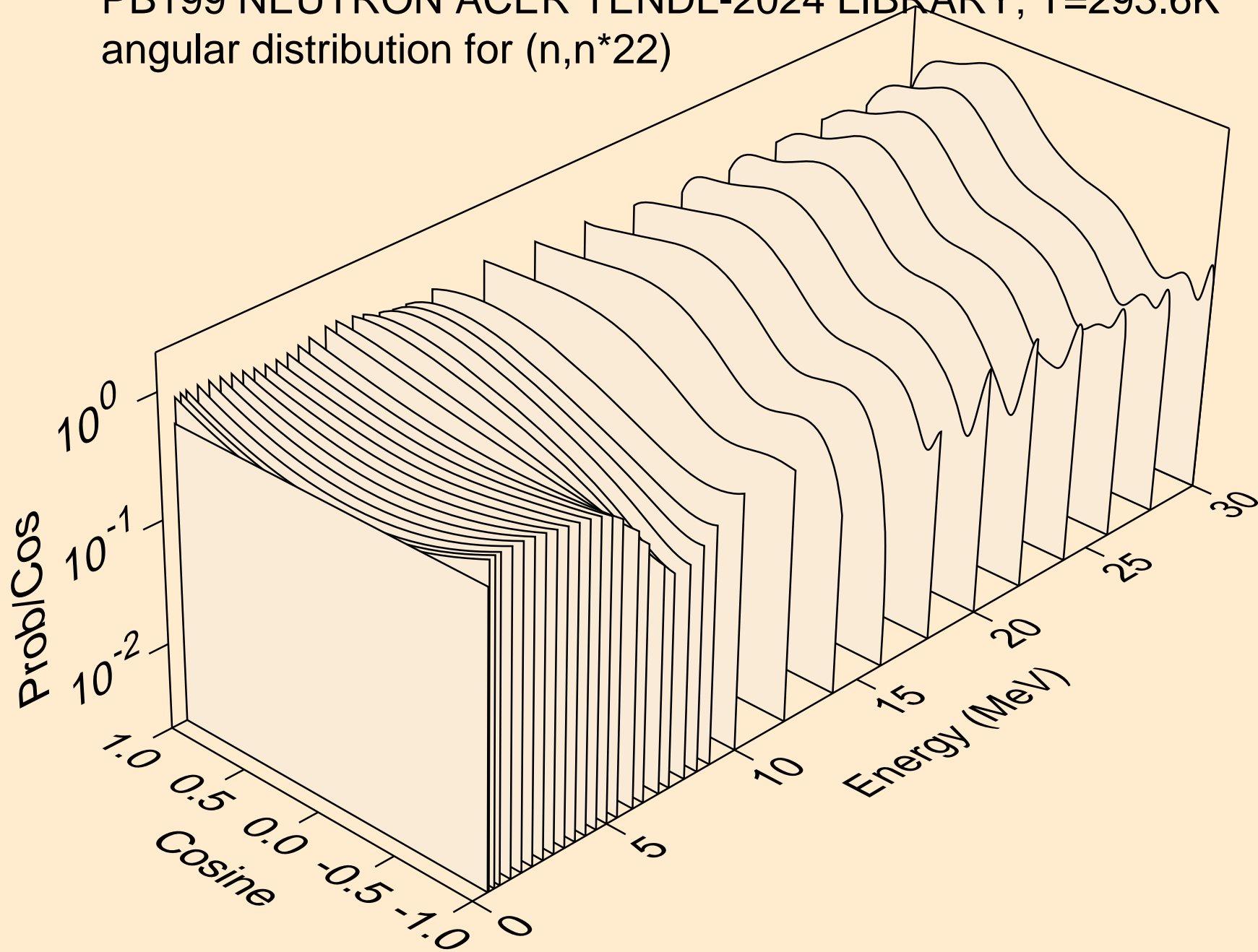

PB199 NEUTRON ACER TENDL-2024 LIBRARY; T=293.6K  
angular distribution for (n,n\*23)

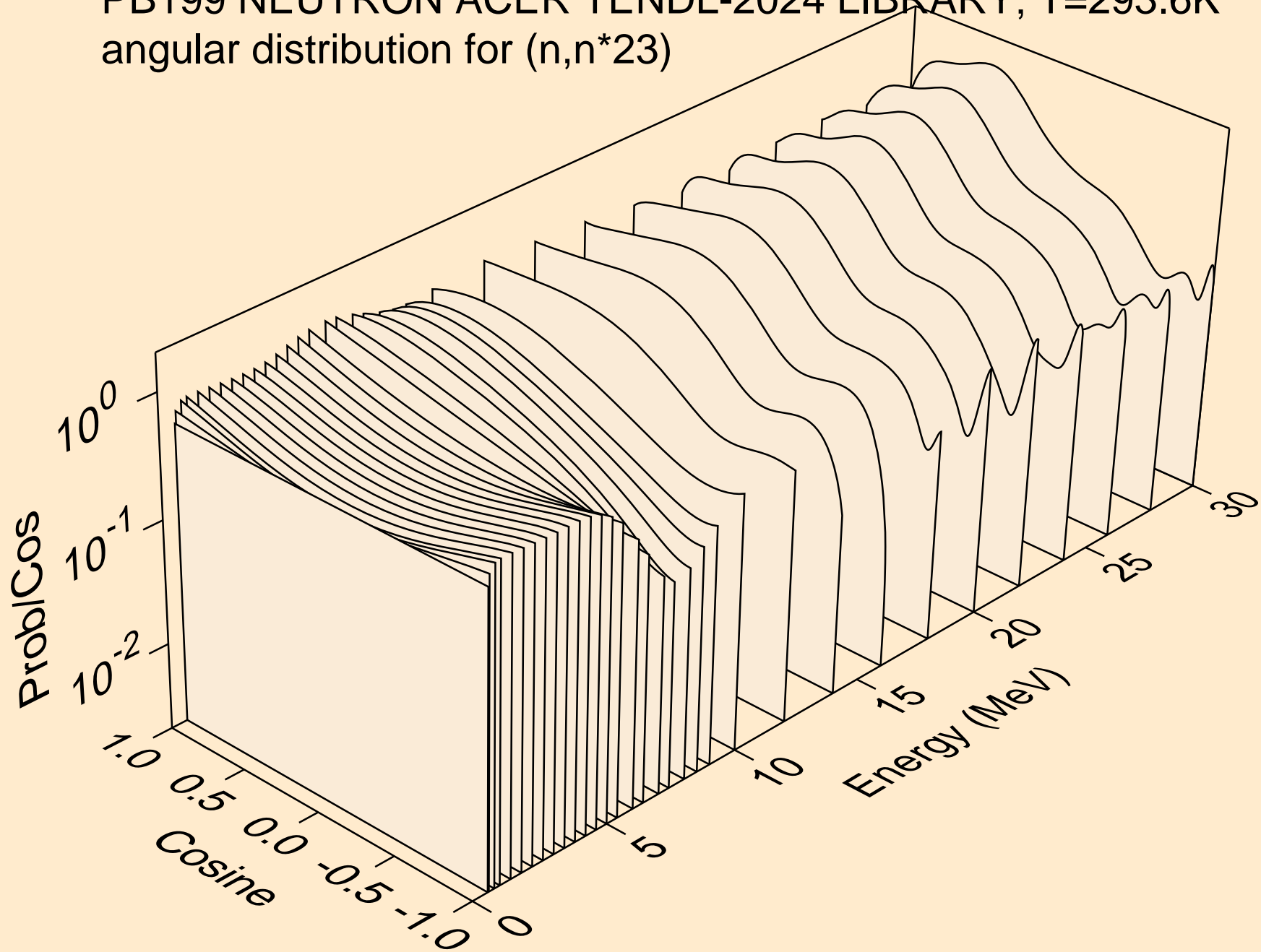

PB199 NEUTRON ACER TENDL-2024 LIBRARY; T=293.6K  
angular distribution for (n,n\*24)

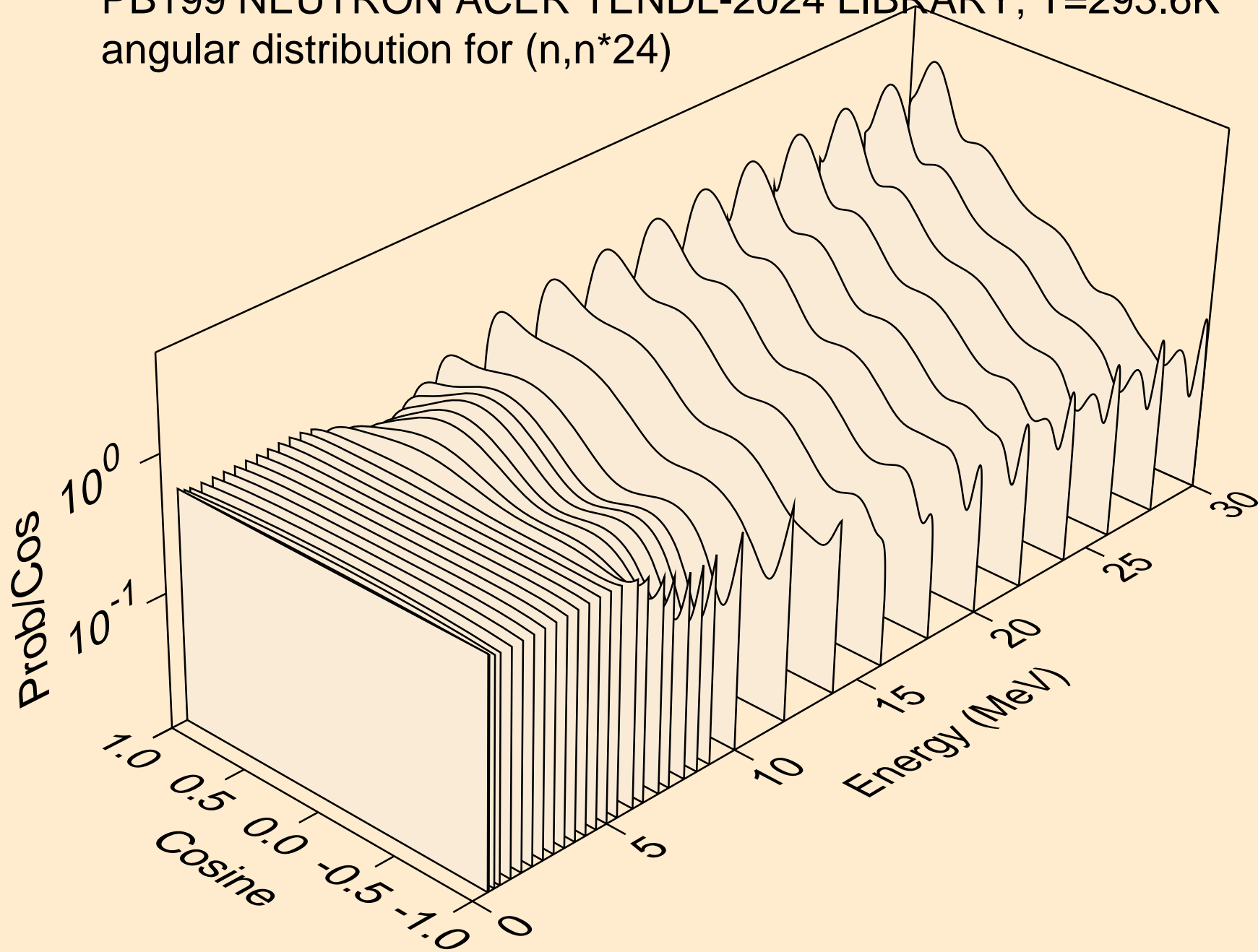

PB199 NEUTRON ACER TENDL-2024 LIBRARY; T=293.6K  
angular distribution for (n,n\*25)

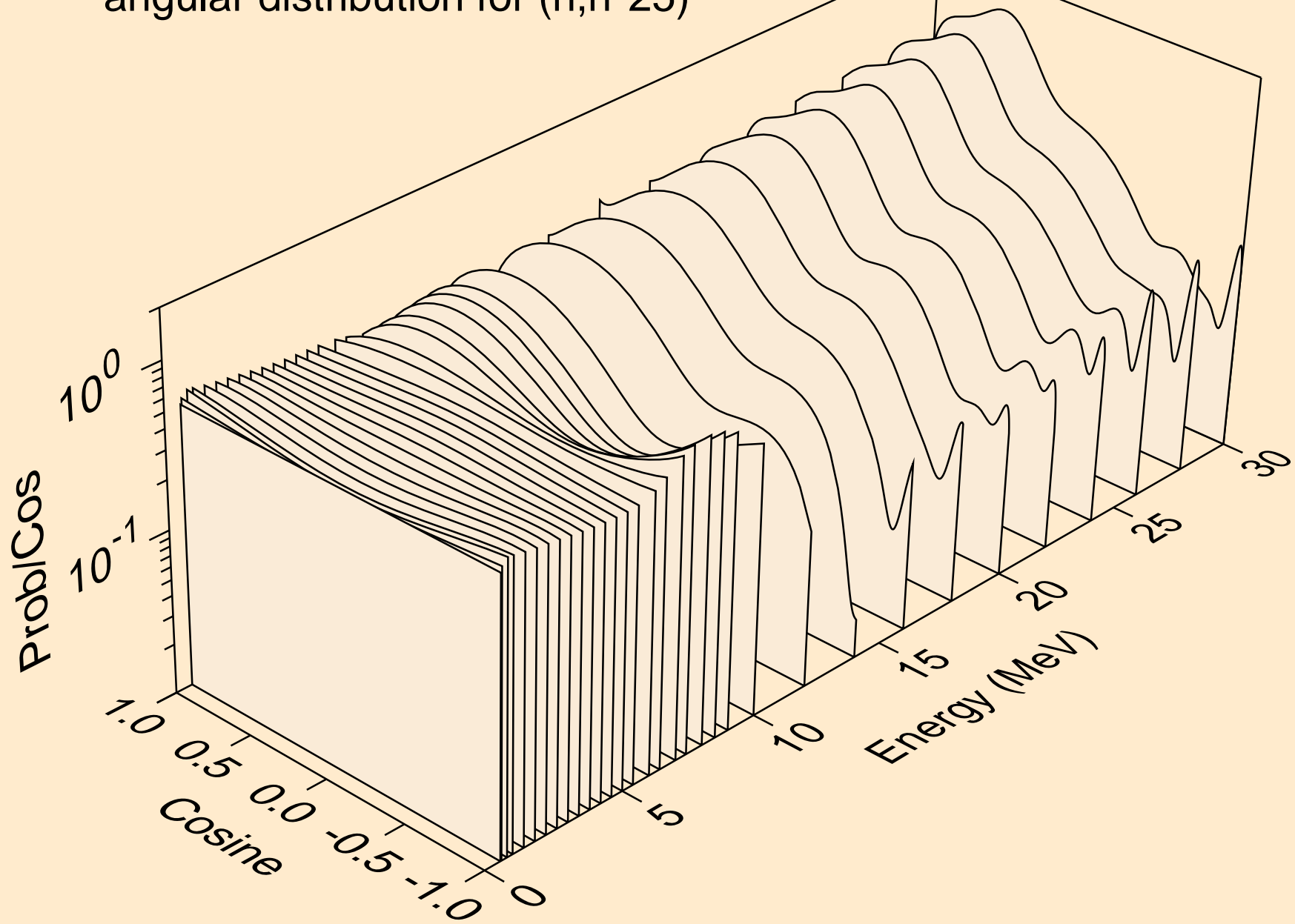

PB199 NEUTRON ACER TENDL-2024 LIBRARY; T=293.6K  
angular distribution for (n,n\*26)

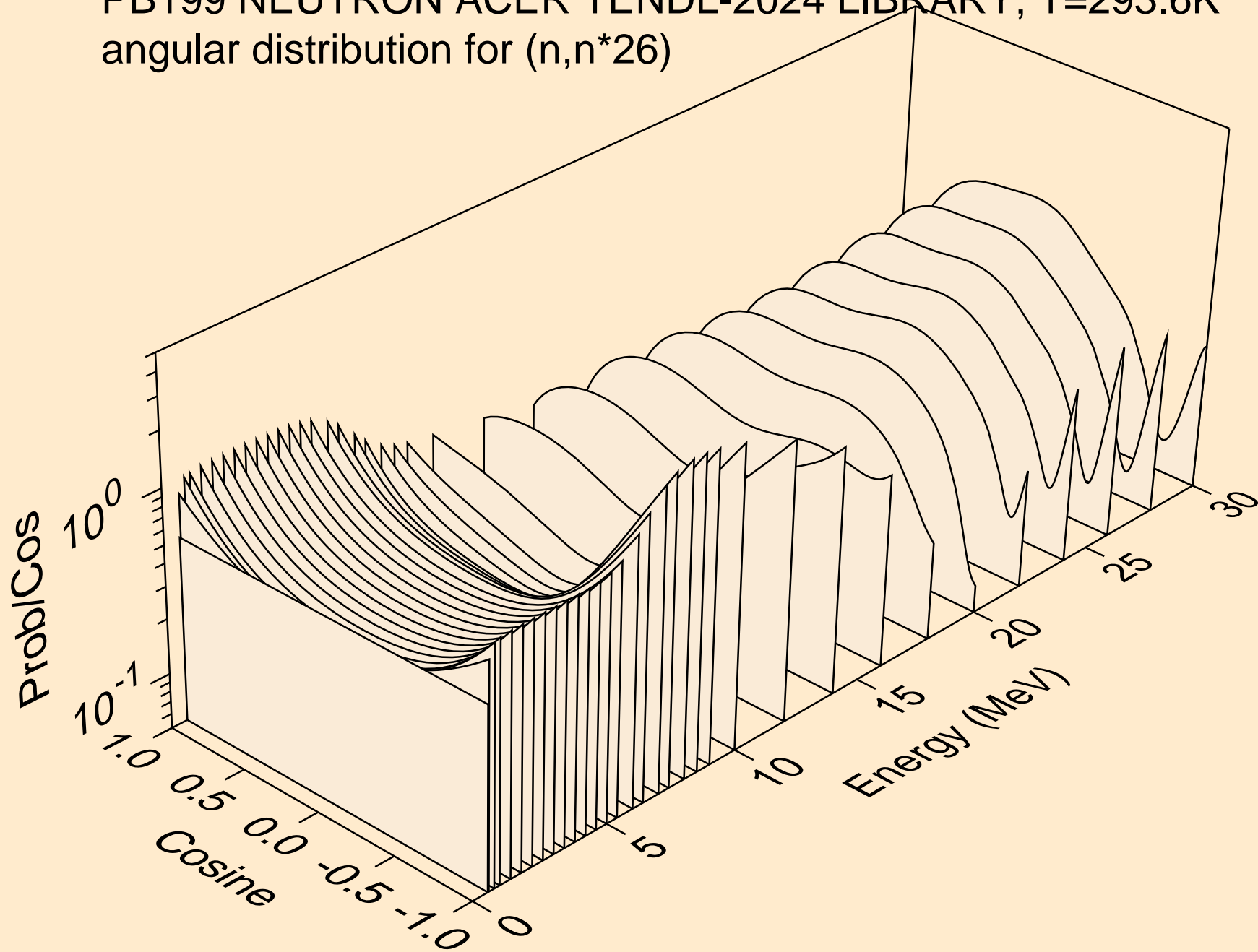

PB199 NEUTRON ACER TENDL-2024 LIBRARY; T=293.6K  
angular distribution for (n,n\*27)

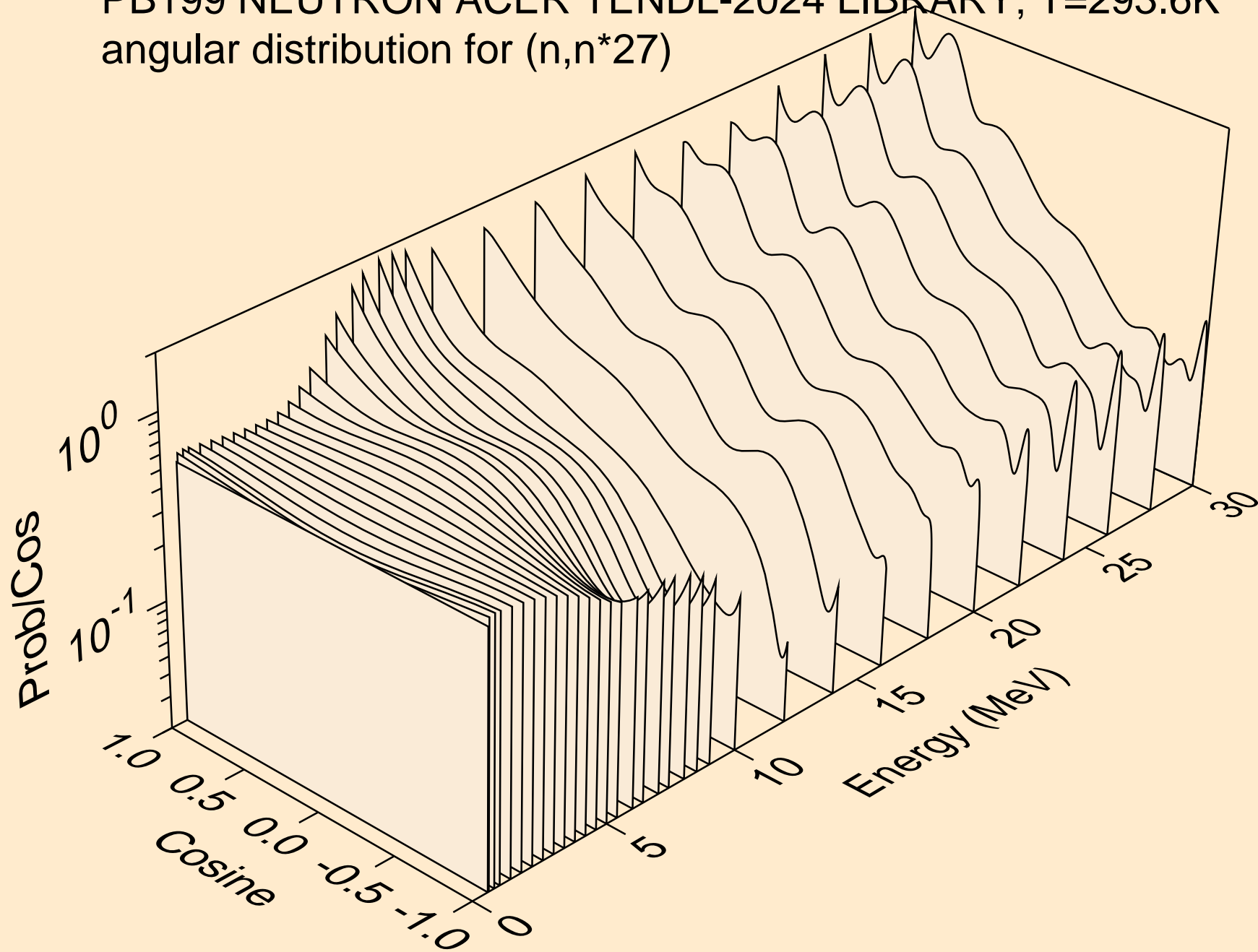

PB199 NEUTRON ACER TENDL-2024 LIBRARY; T=293.6K  
angular distribution for (n,n\*28)

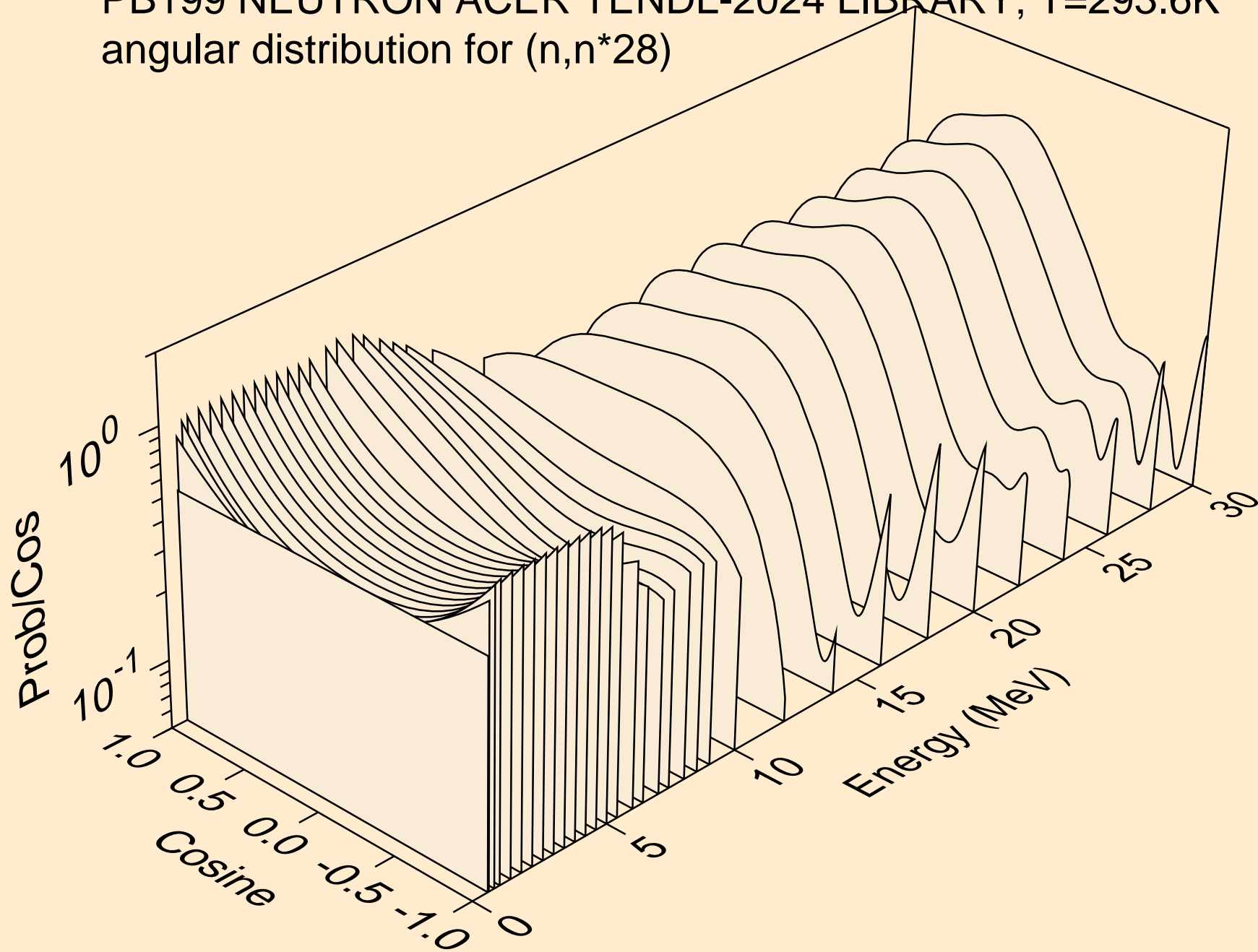

PB199 NEUTRON ACER TENDL-2024 LIBRARY; T=293.6K  
angular distribution for (n,n\*29)

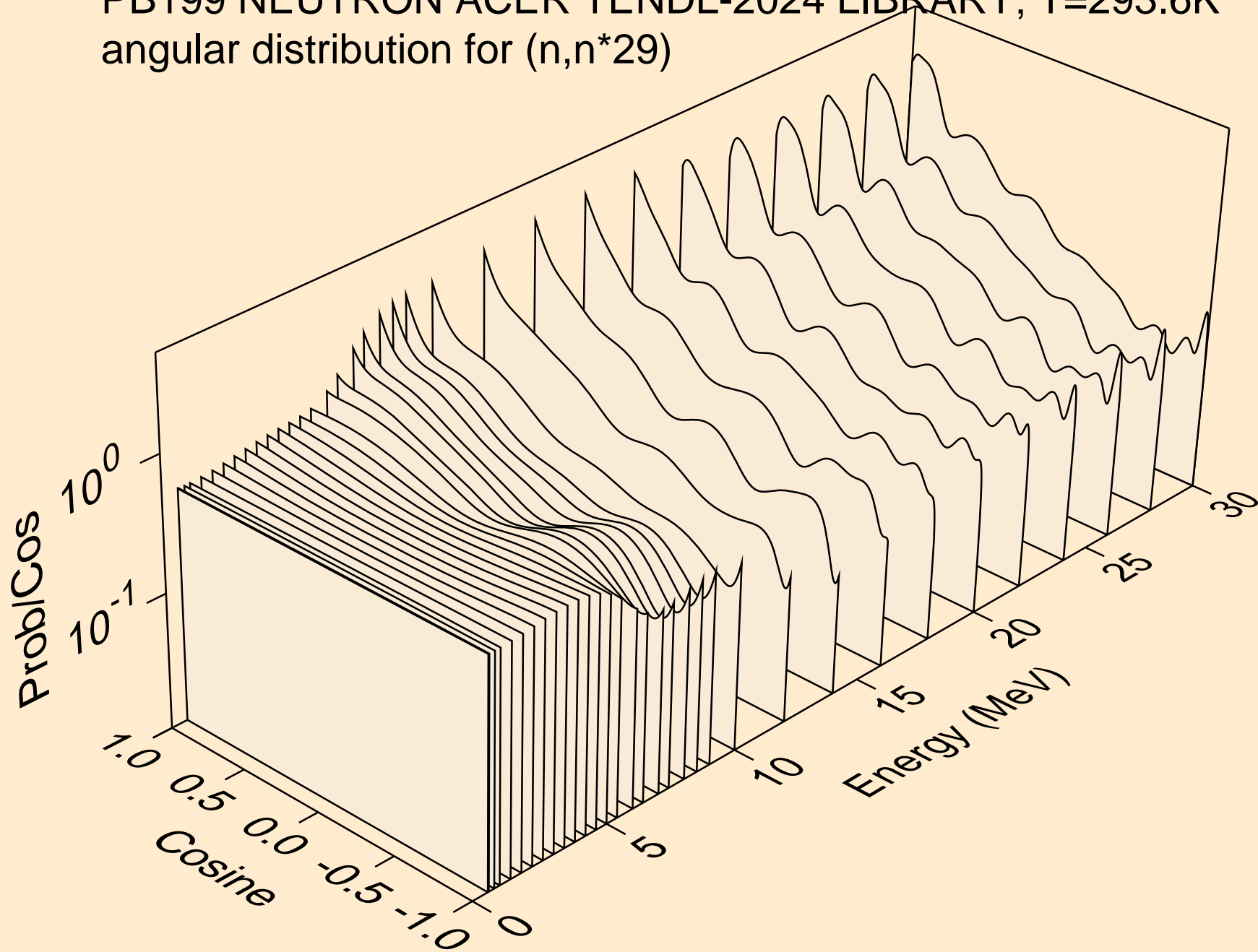

PB199 NEUTRON ACER TENDL-2024 LIBRARY; T=293.6K  
angular distribution for (n,n\*30)

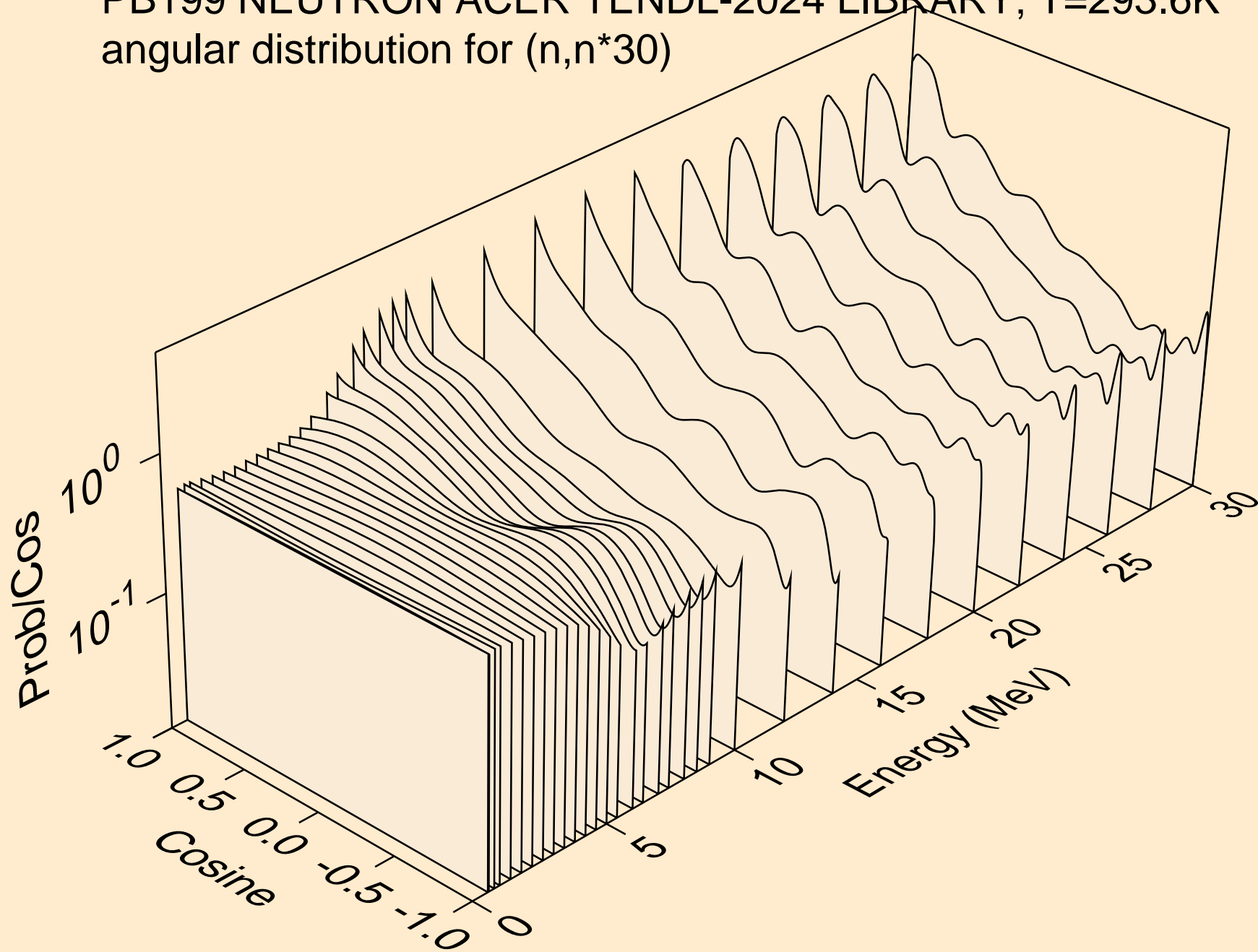

PB199 NEUTRON ACER TENDL-2024 LIBRARY; T=293.6K  
Neutron emission for (n,x)

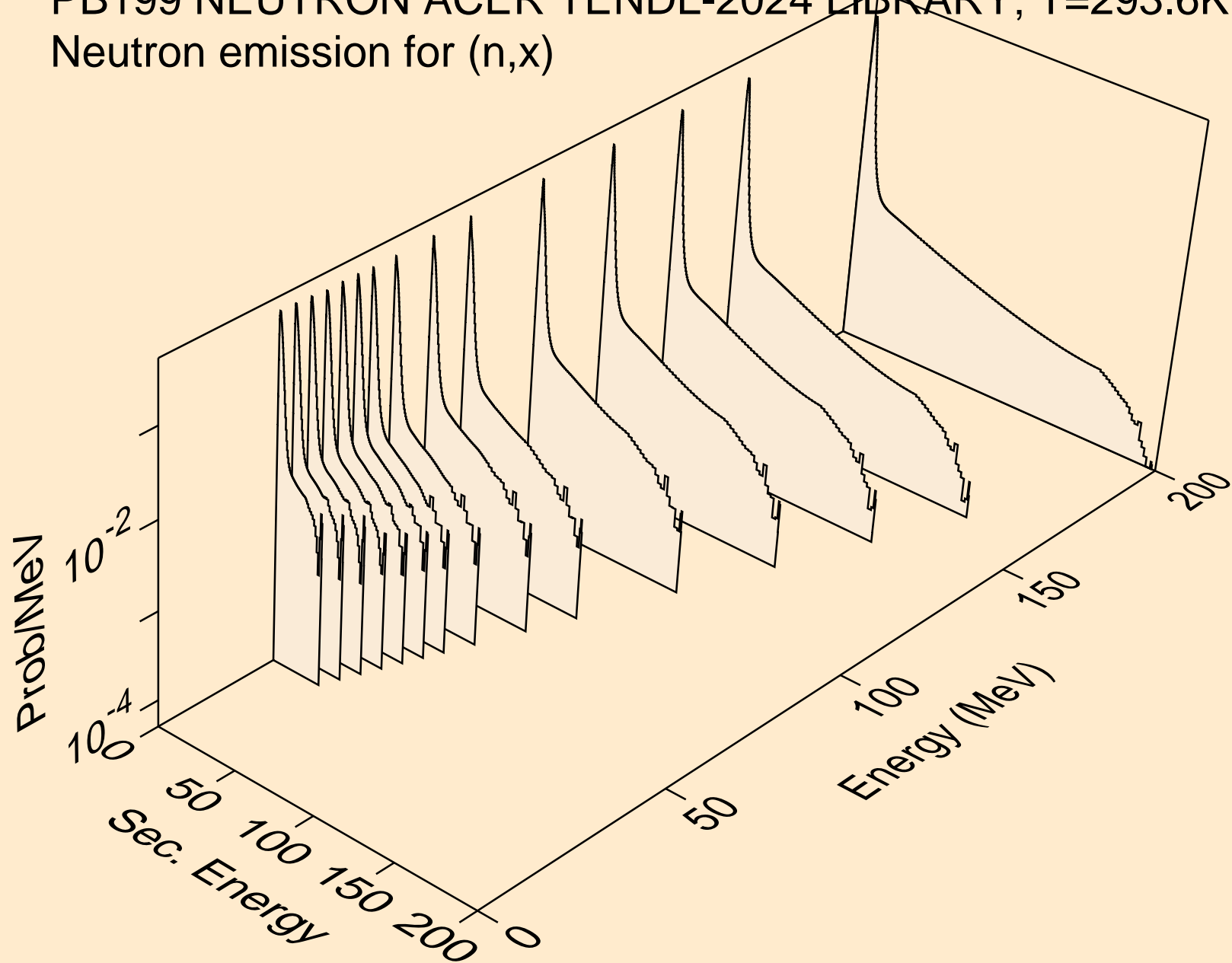

PB199 NEUTRON ACER TENDL-2024 LIBRARY; T=293.6K  
Neutron emission for (n,2nd)

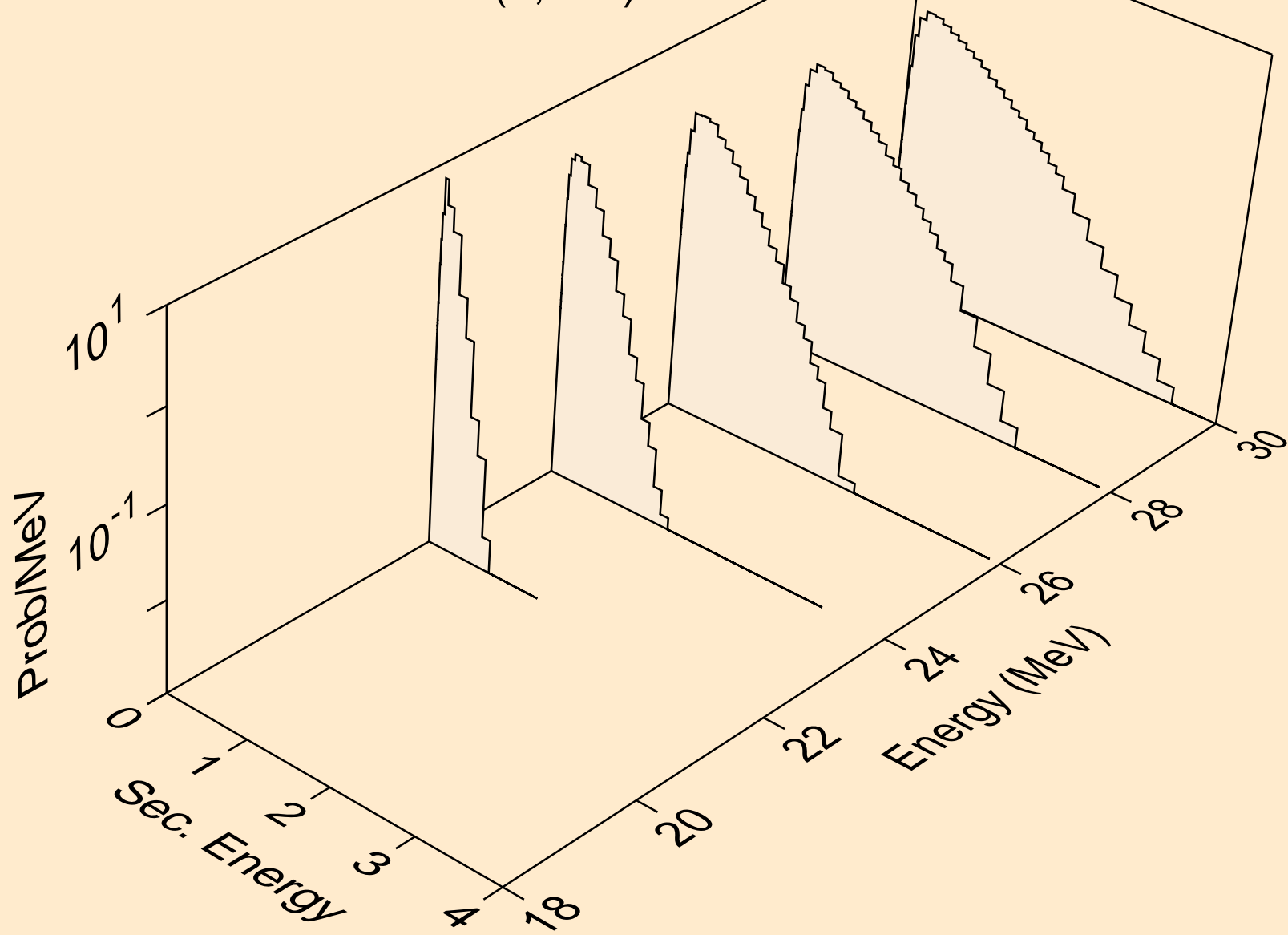

PB199 NEUTRON ACER TENDL-2024 LIBRARY; T=293.6K  
Neutron emission for (n,2n)

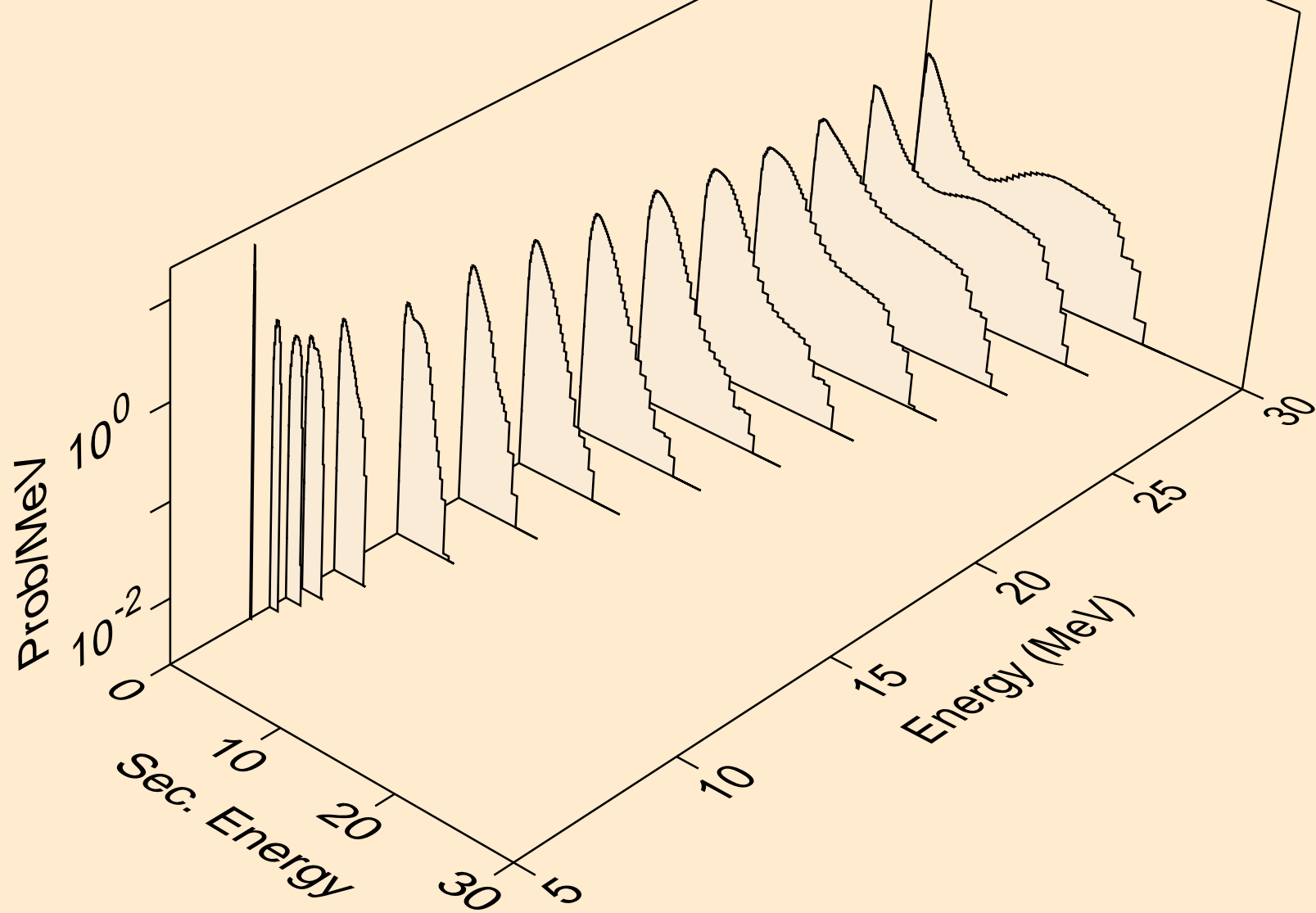

PB199 NEUTRON ACER TENDL-2024 LIBRARY; T=293.6K  
Neutron emission for (n,3n)

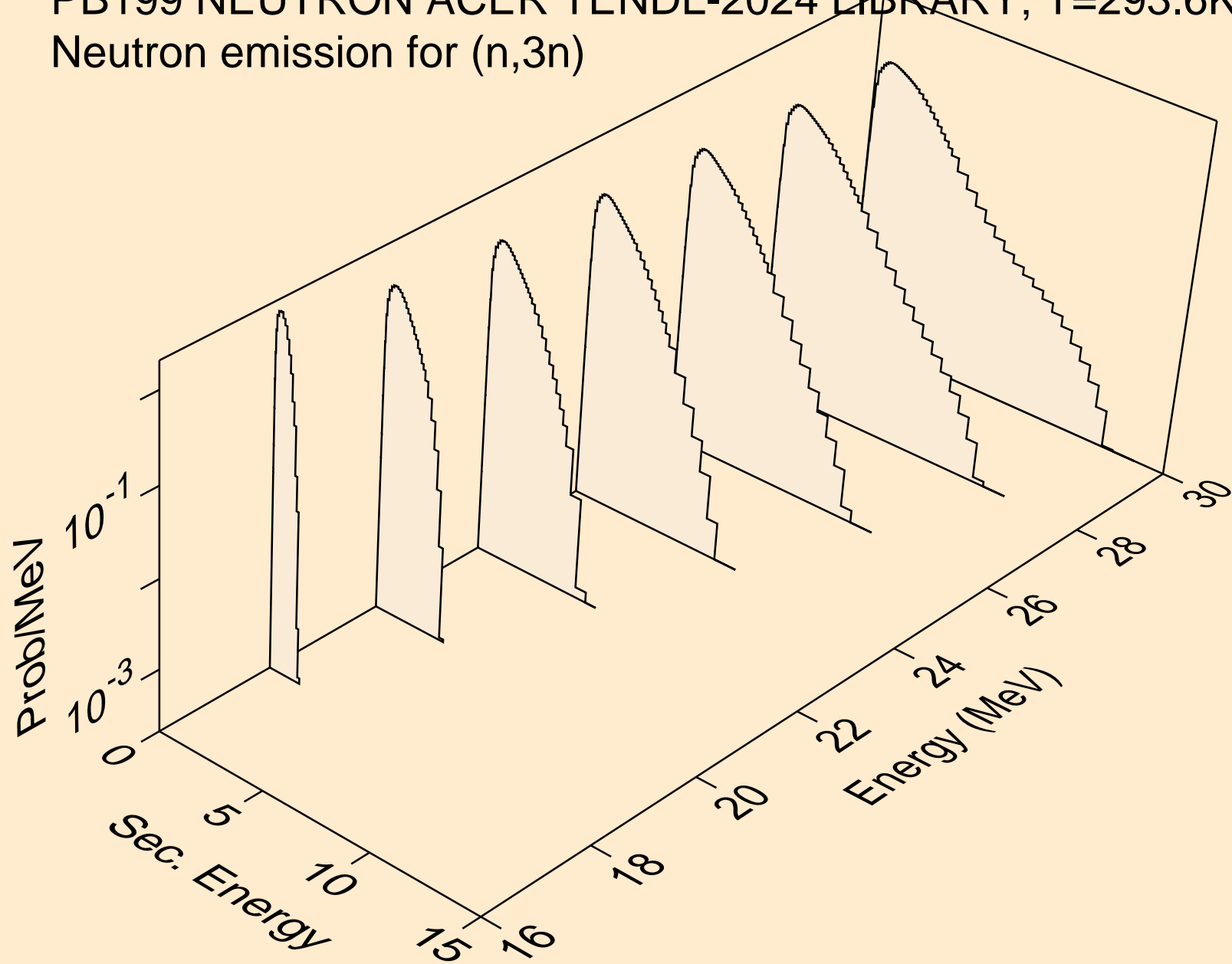

PB199 NEUTRON ACER TENDL-2024 LIBRARY; T=293.6K  
Neutron emission for (n,n\*)a



PB199 NEUTRON ACER TENDL-2024 LIBRARY; T=293.6K  
Neutron emission for (n,2n)a

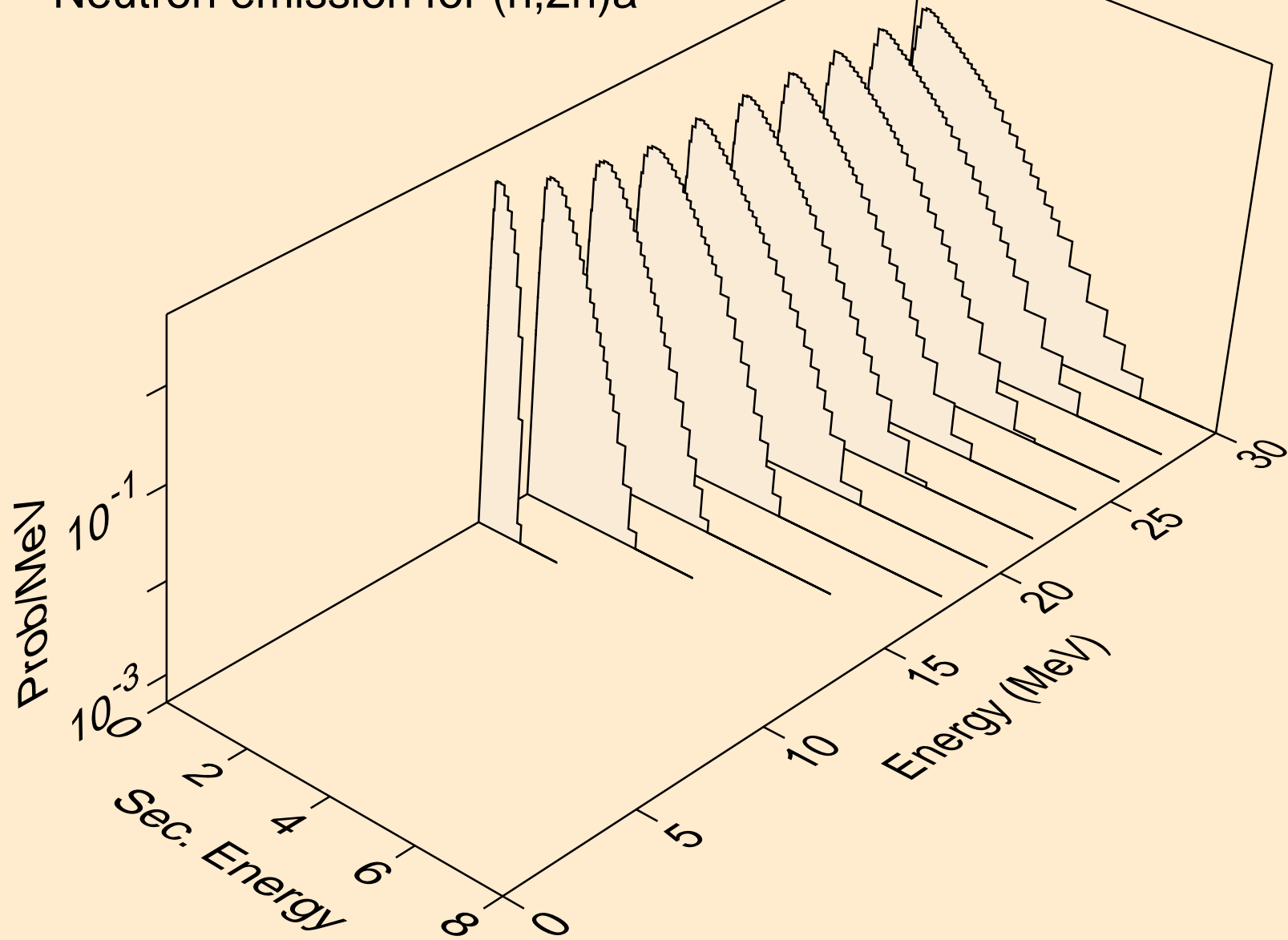

PB199 NEUTRON ACER TENDL-2024 LIBRARY; T=293.6K  
Neutron emission for (n,3n)a

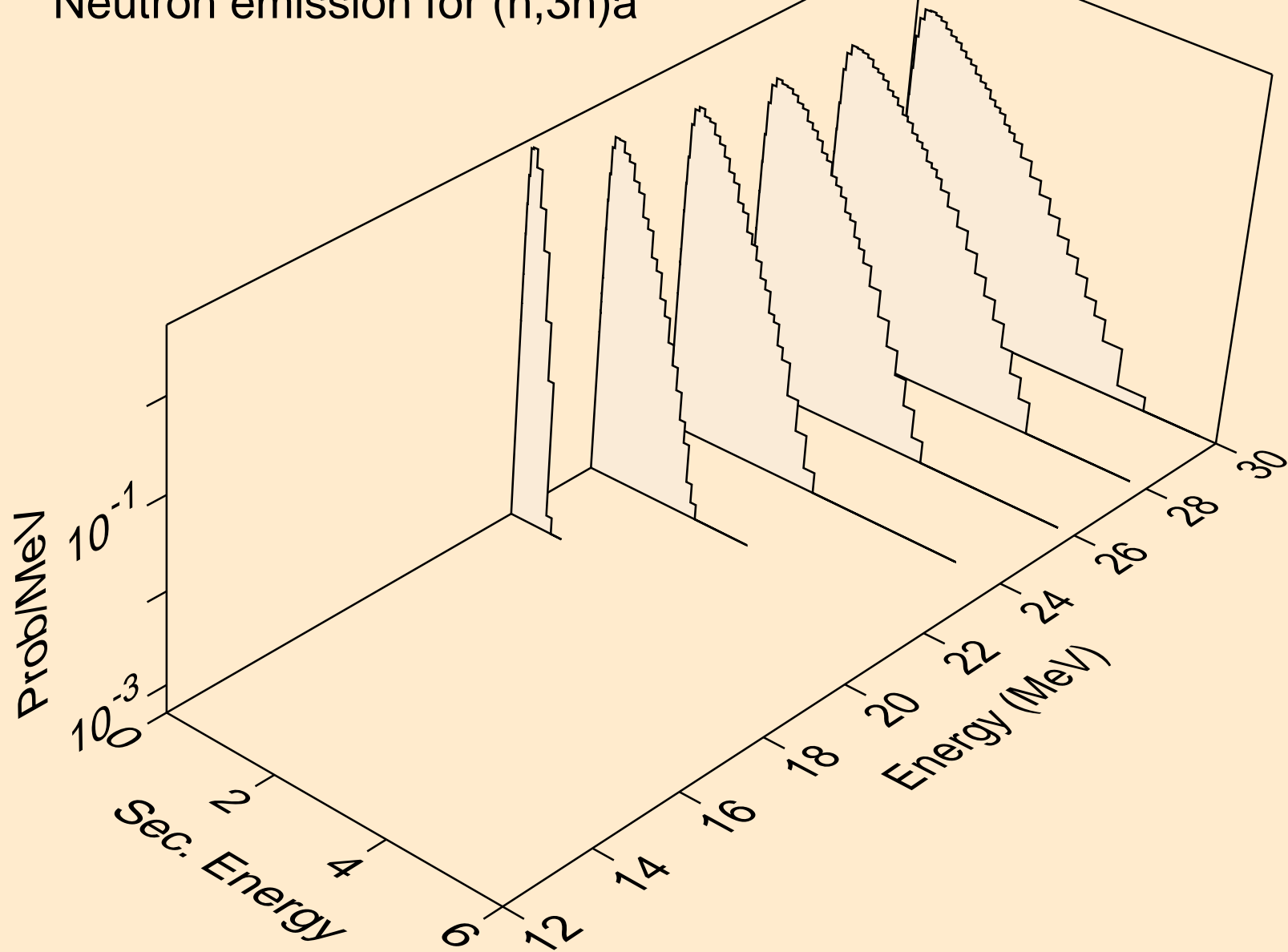

PB199 NEUTRON ACER TENDL-2024 LIBRARY; T=293.6K  
Neutron emission for (n,n\*)p

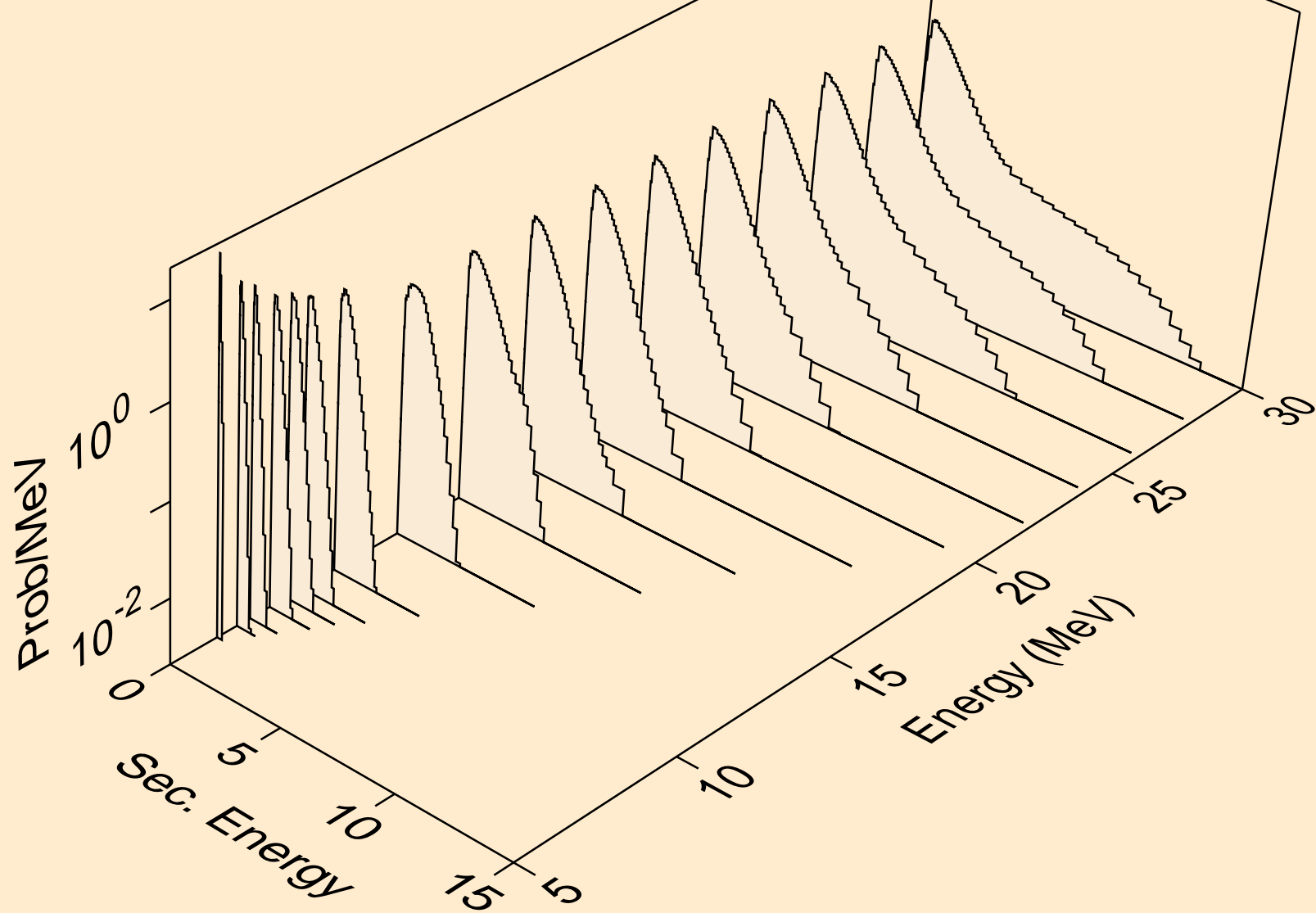

PB199 NEUTRON ACER TENDL-2024 LIBRARY; T=293.6K  
Neutron emission for (n,n\*)2a

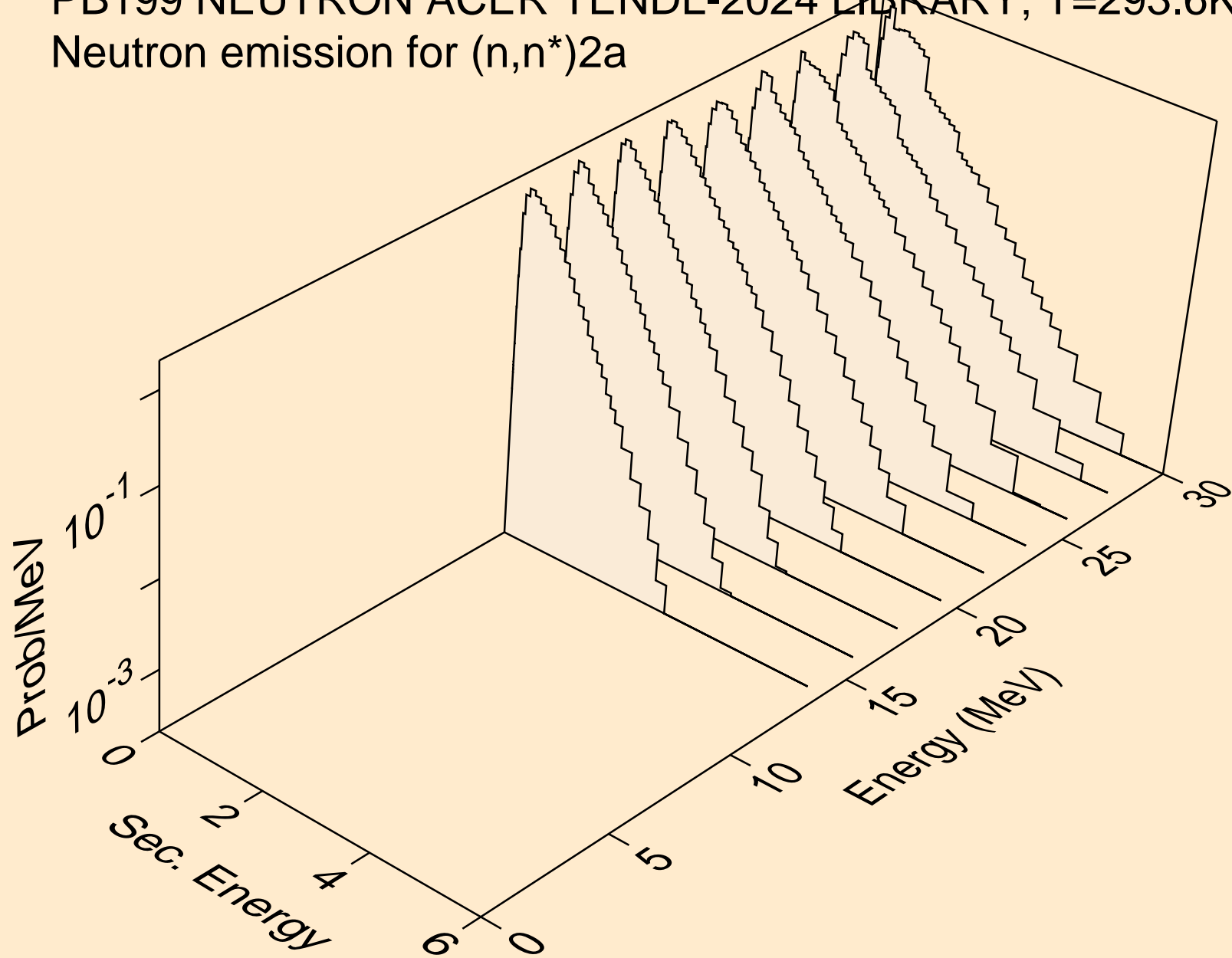

PB199 NEUTRON ACER TENDL-2024 LIBRARY; T=293.6K  
Neutron emission for (n,n\*)d

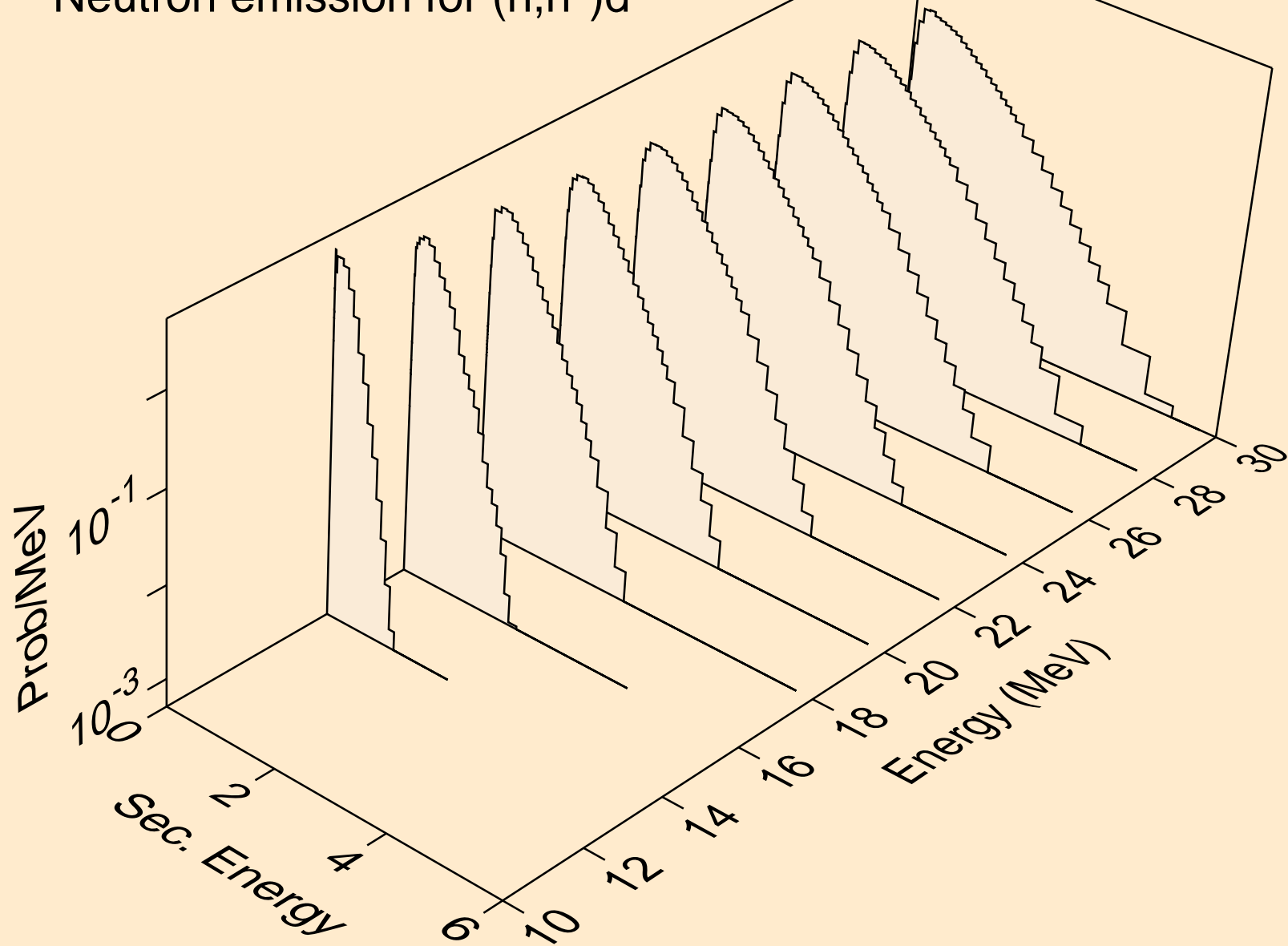

PB199 NEUTRON ACER TENDL-2024 LIBRARY; T=293.6K  
Neutron emission for (n,n\*)t

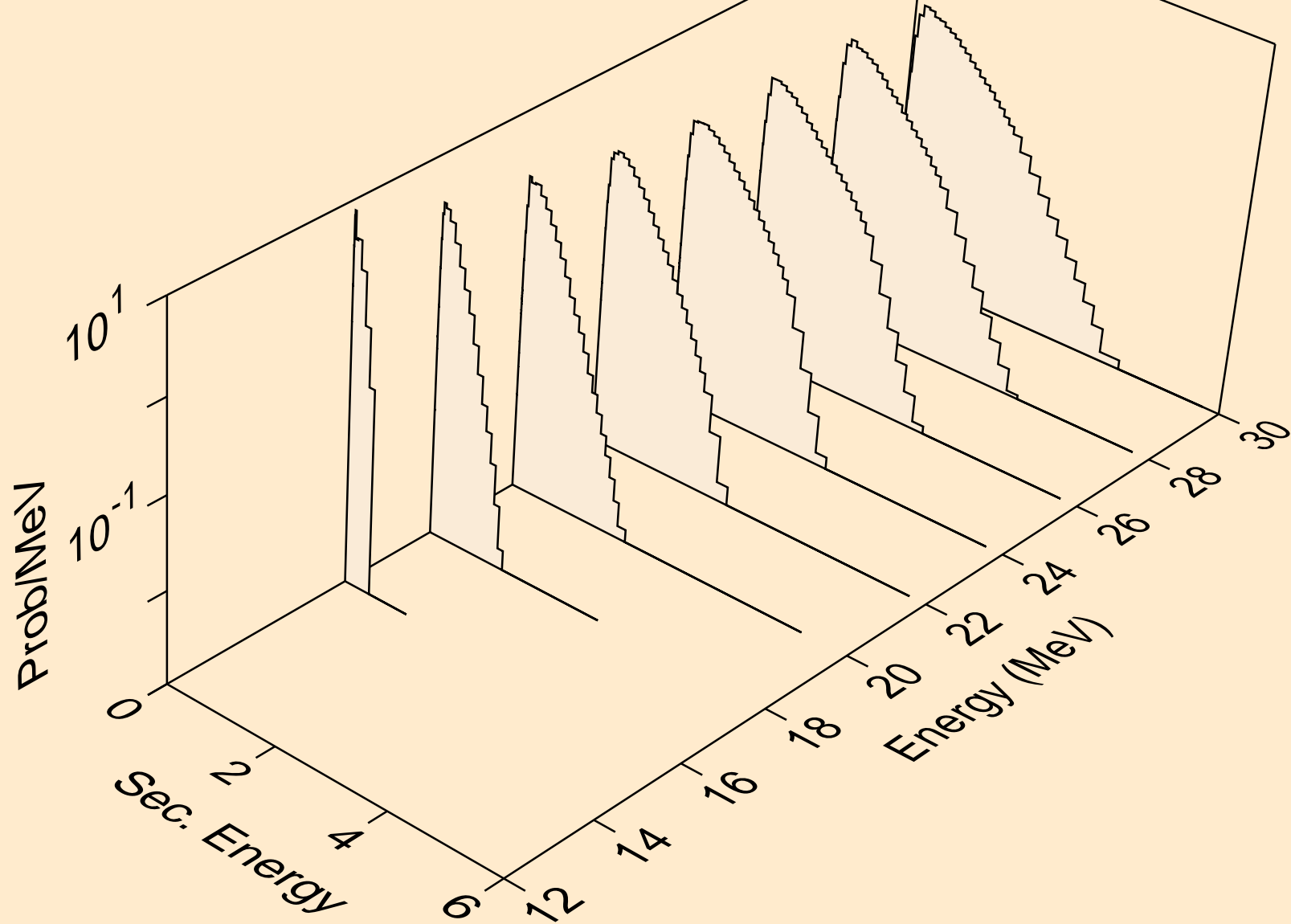

PB199 NEUTRON ACER TENDL-2024 LIBRARY; T=293.6K  
Neutron emission for (n,n\*)he3

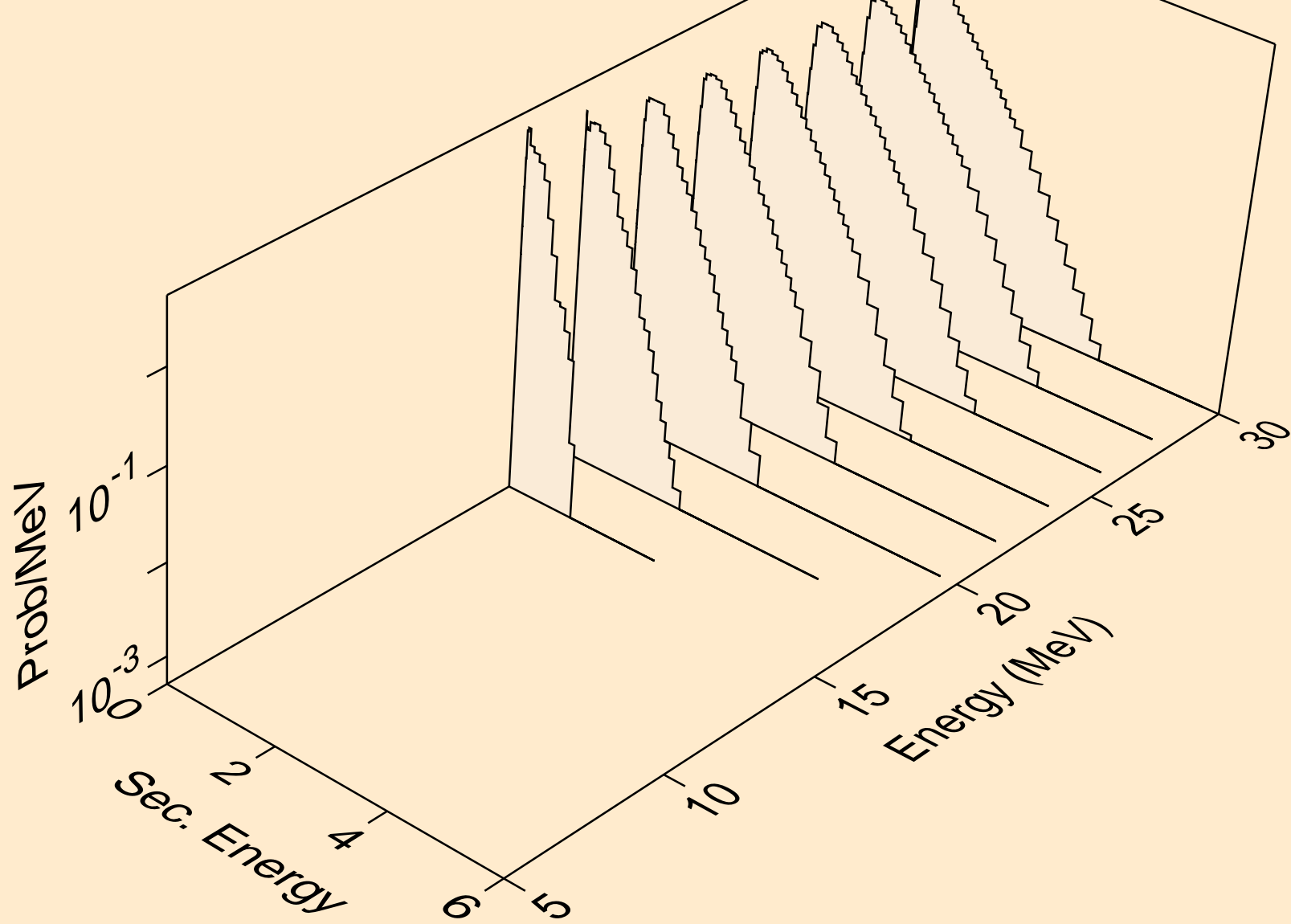

PB199 NEUTRON ACER TENDL-2024 LIBRARY; T=293.6K  
Neutron emission for (n,4n)

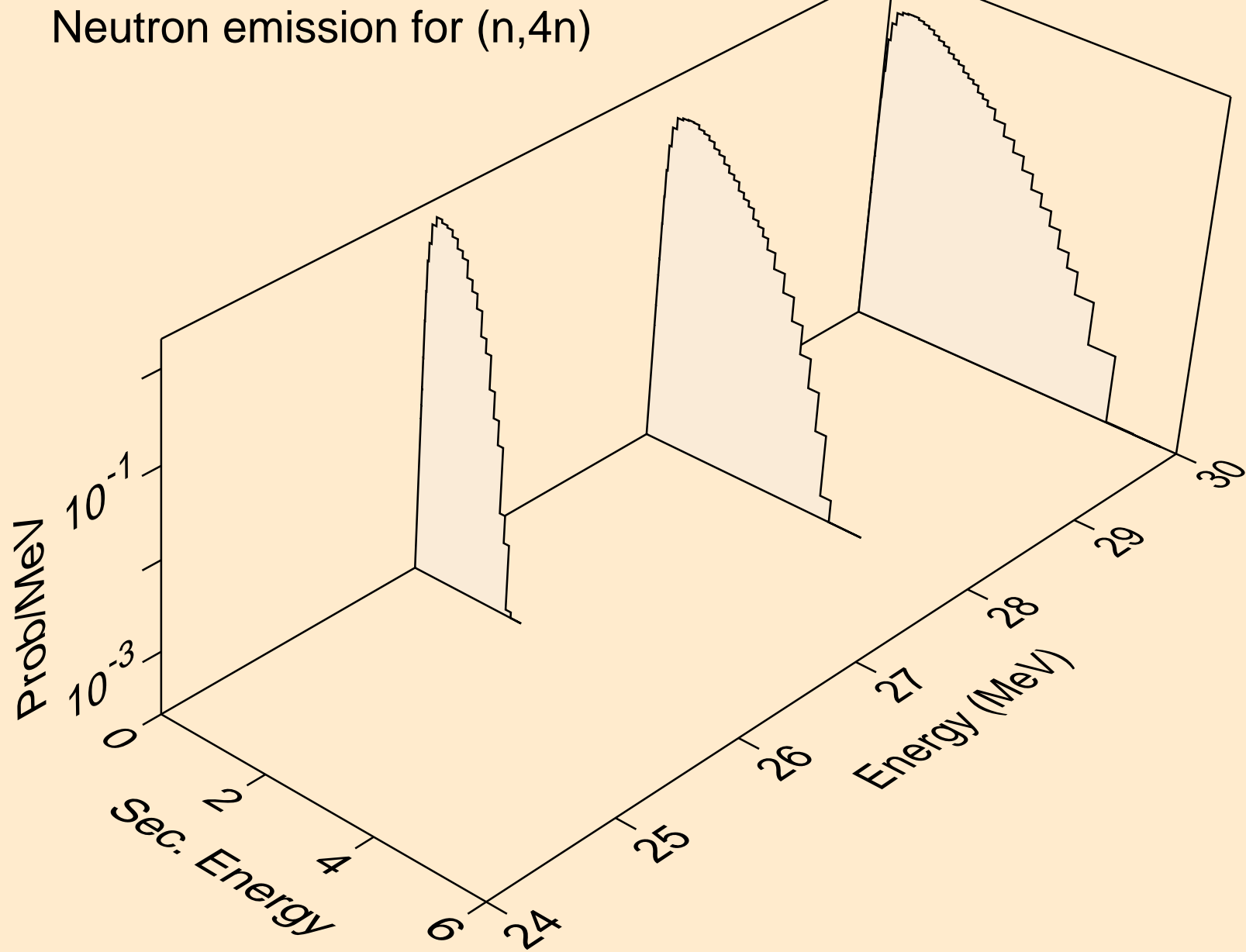

PB199 NEUTRON ACER TENDL-2024 LIBRARY; T=293.6K  
Neutron emission for (n,2np)

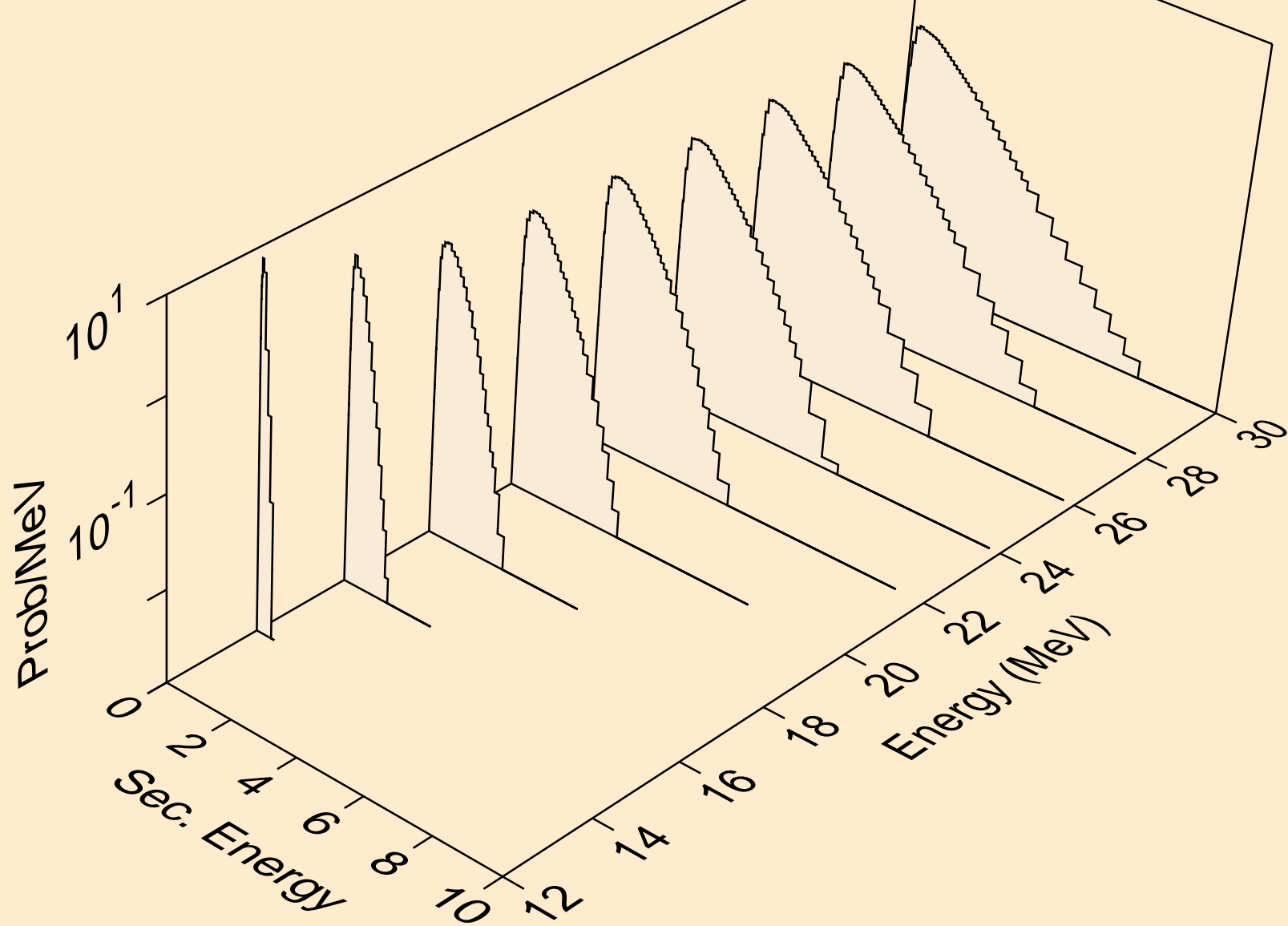

PB199 NEUTRON ACER TENDL-2024 LIBRARY; T=293.6K  
Neutron emission for (n,3np)

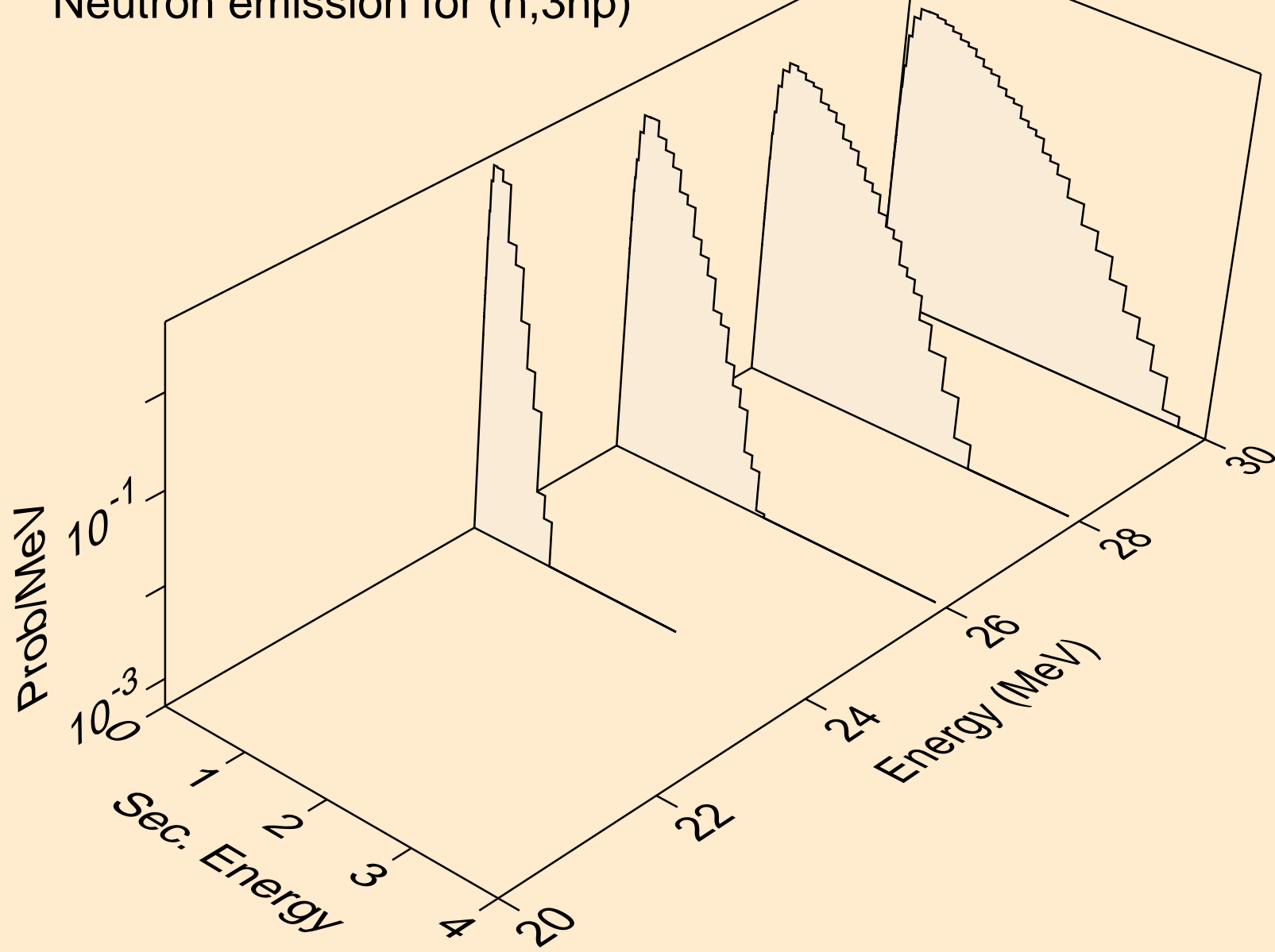

PB199 NEUTRON ACER TENDL-2024 LIBRARY; T=293.6K  
Neutron emission for (n,n2p)

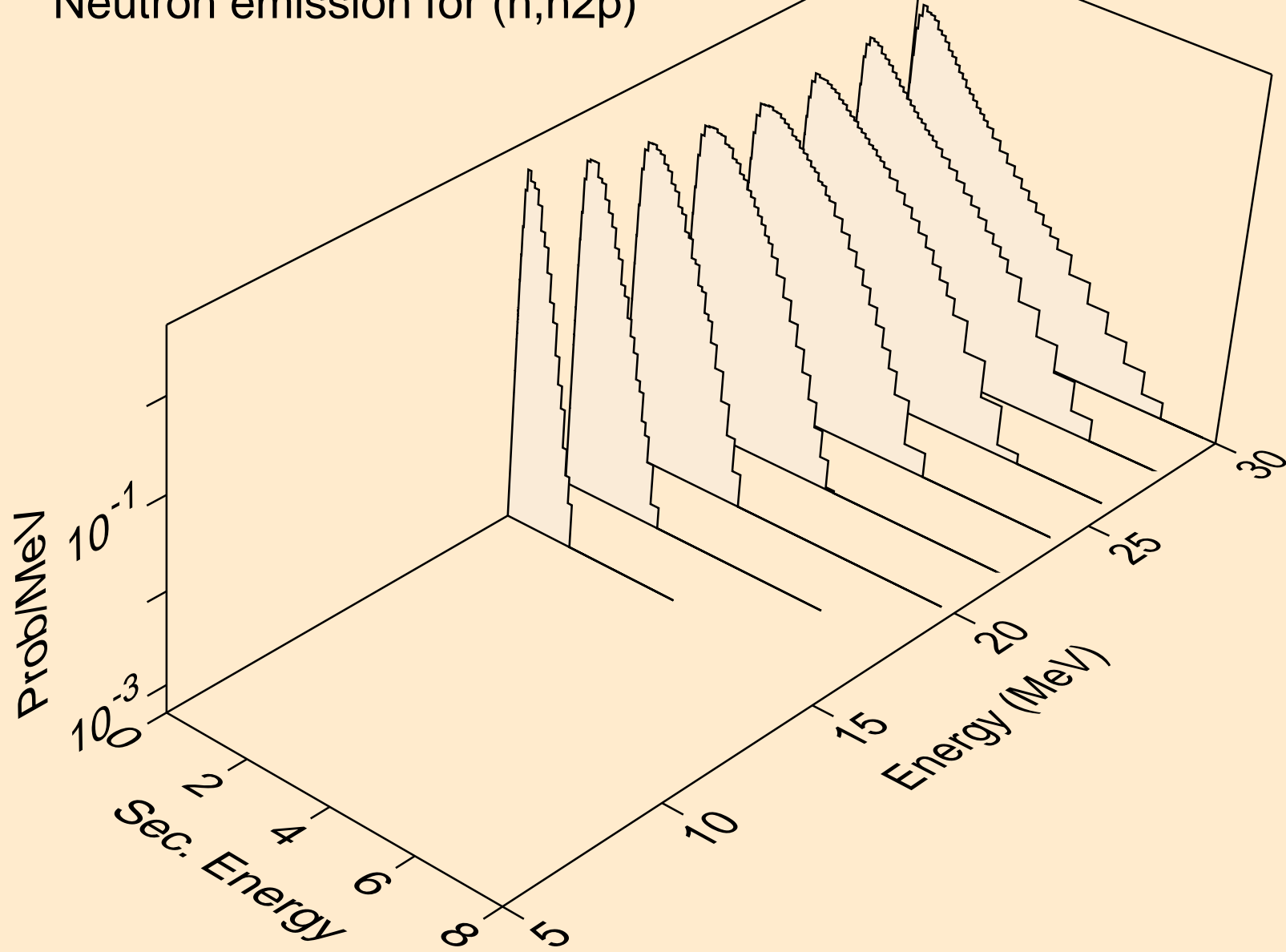

PB199 NEUTRON ACER TENDL-2024 LIBRARY; T=293.6K  
Neutron emission for (n,npa)

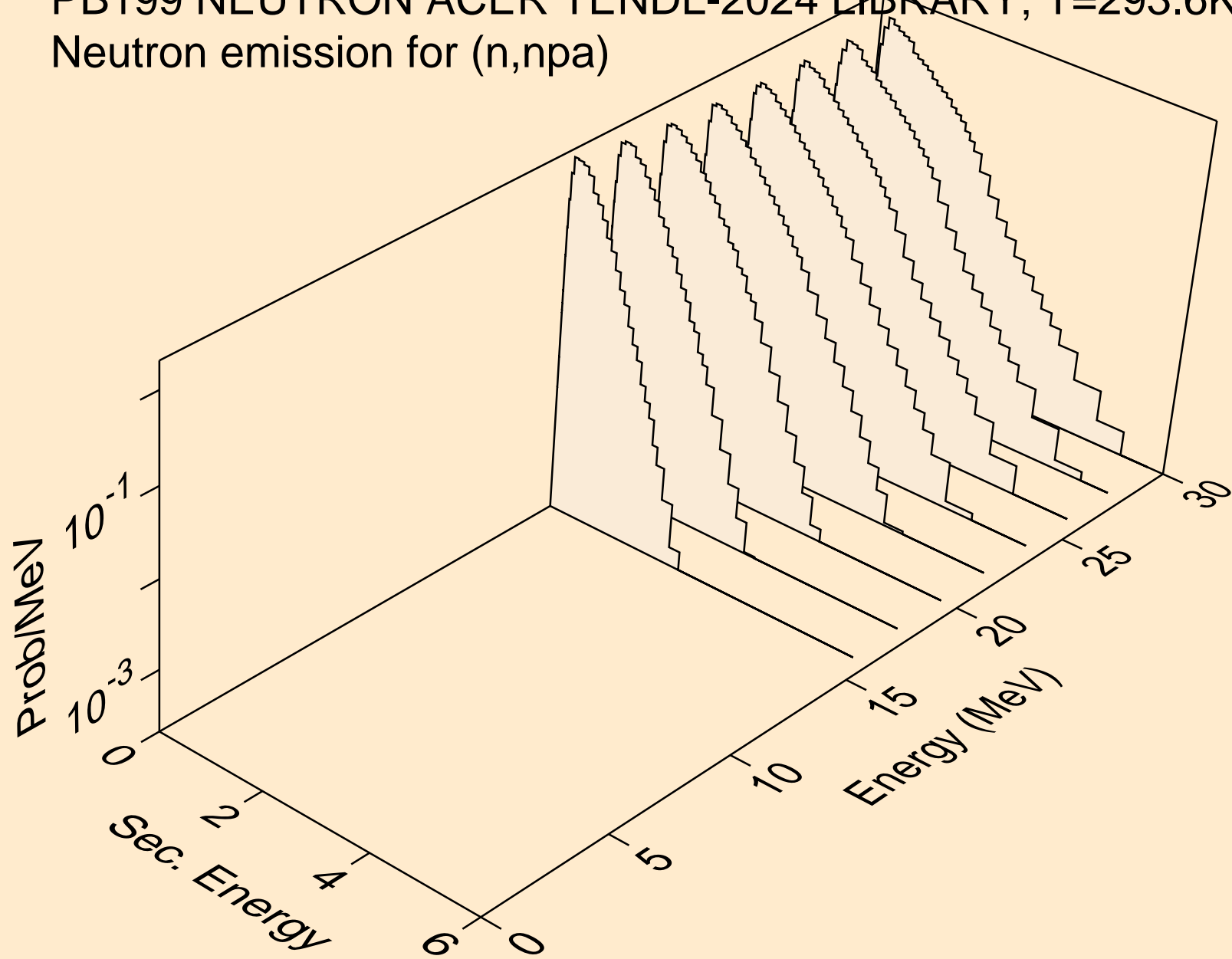

PB199 NEUTRON ACER TENDL-2024 LIBRARY; T=293.6K  
Neutron emission for (n,n\*c)

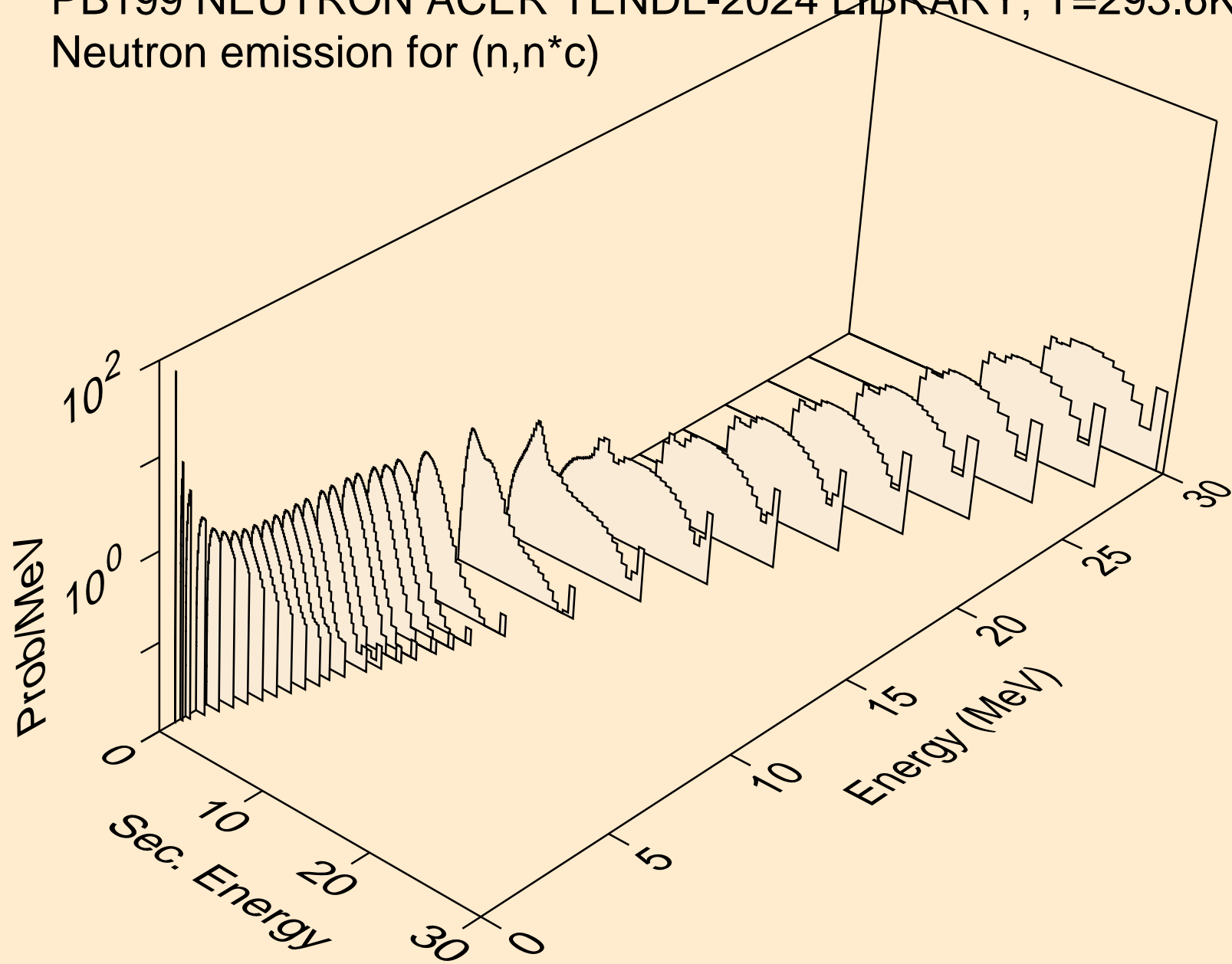

PB199 NEUTRON ACER TENDL-2024 LIBRARY; T=293.6K  
Photon emission for (n,x)

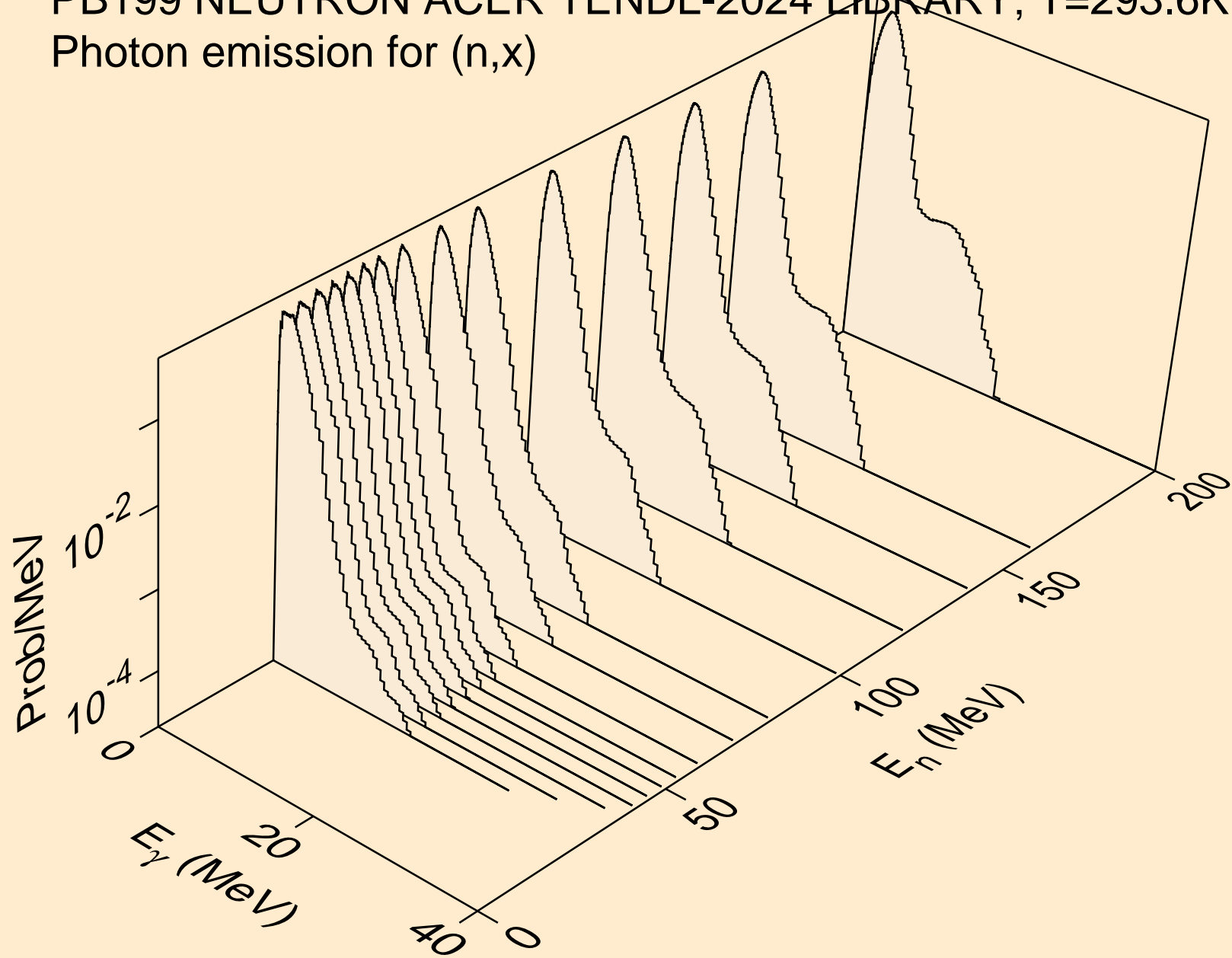

PB199 NEUTRON ACER TENDL-2024 LIBRARY; T=293.6K  
Photon emission for (n,2nd)

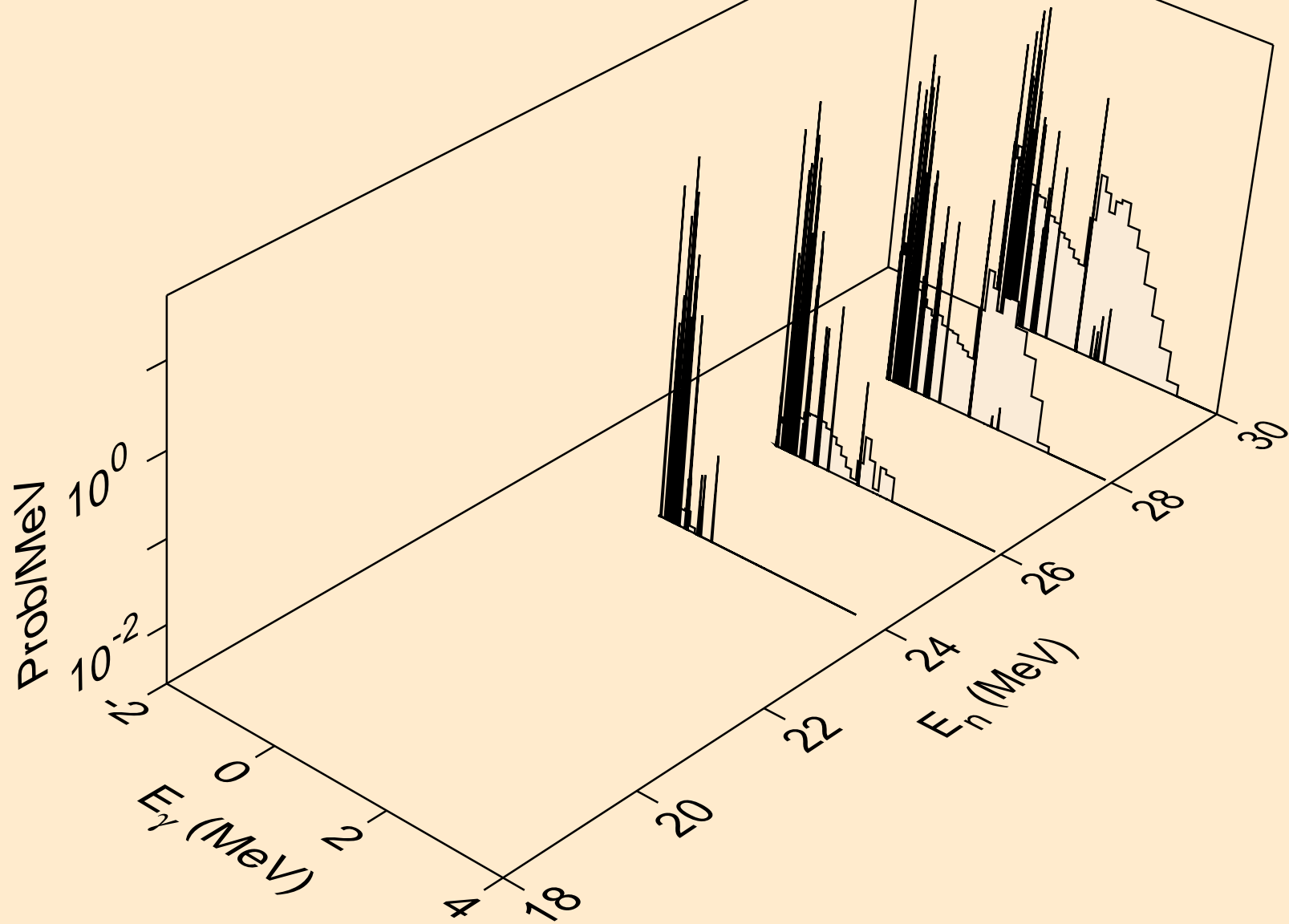

PB199 NEUTRON ACER TENDL-2024 LIBRARY; T=293.6K  
Photon emission for (n,2n)

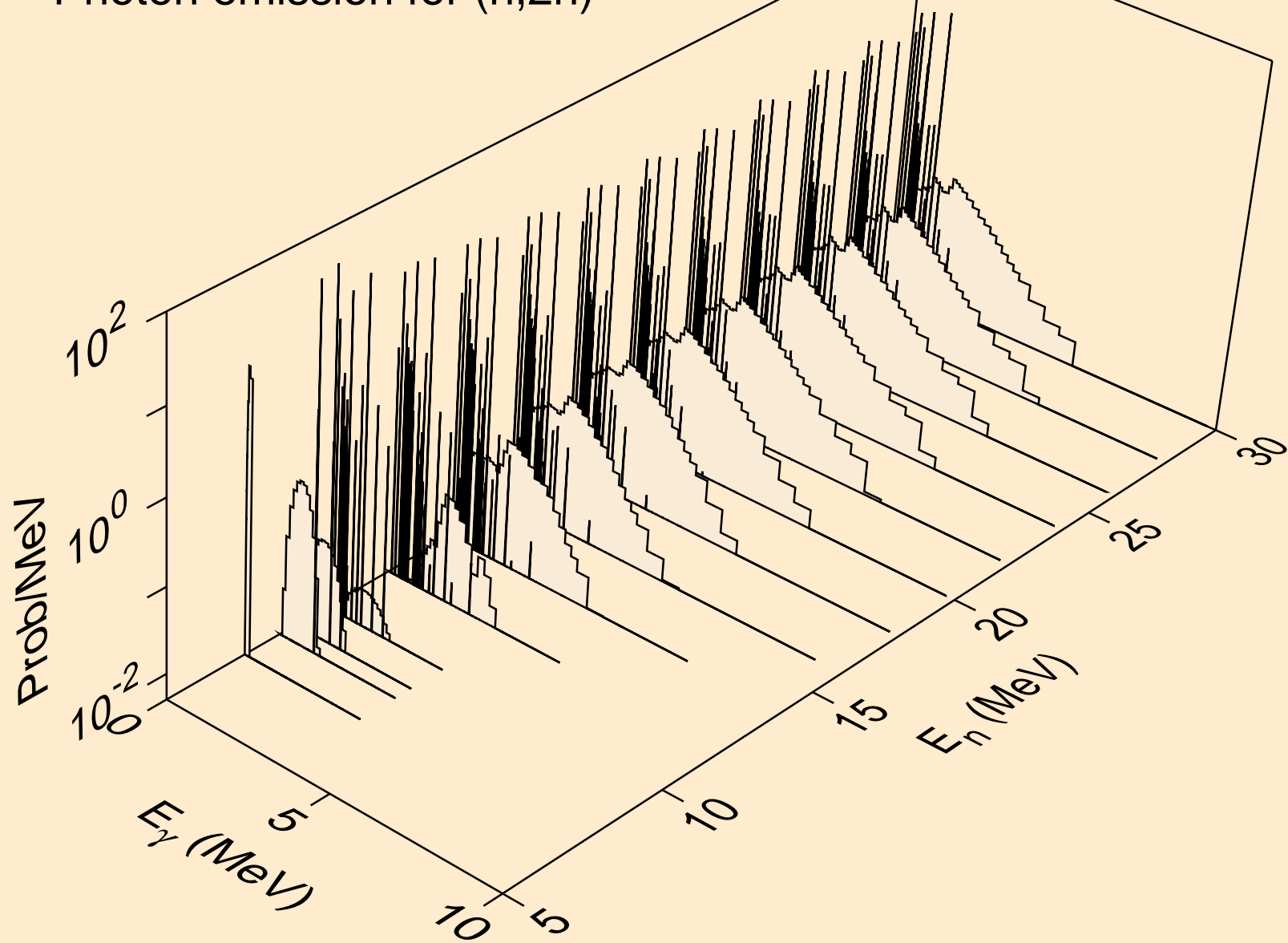

PB199 NEUTRON ACER TENDL-2024 LIBRARY; T=293.6K  
Photon emission for (n,3n)

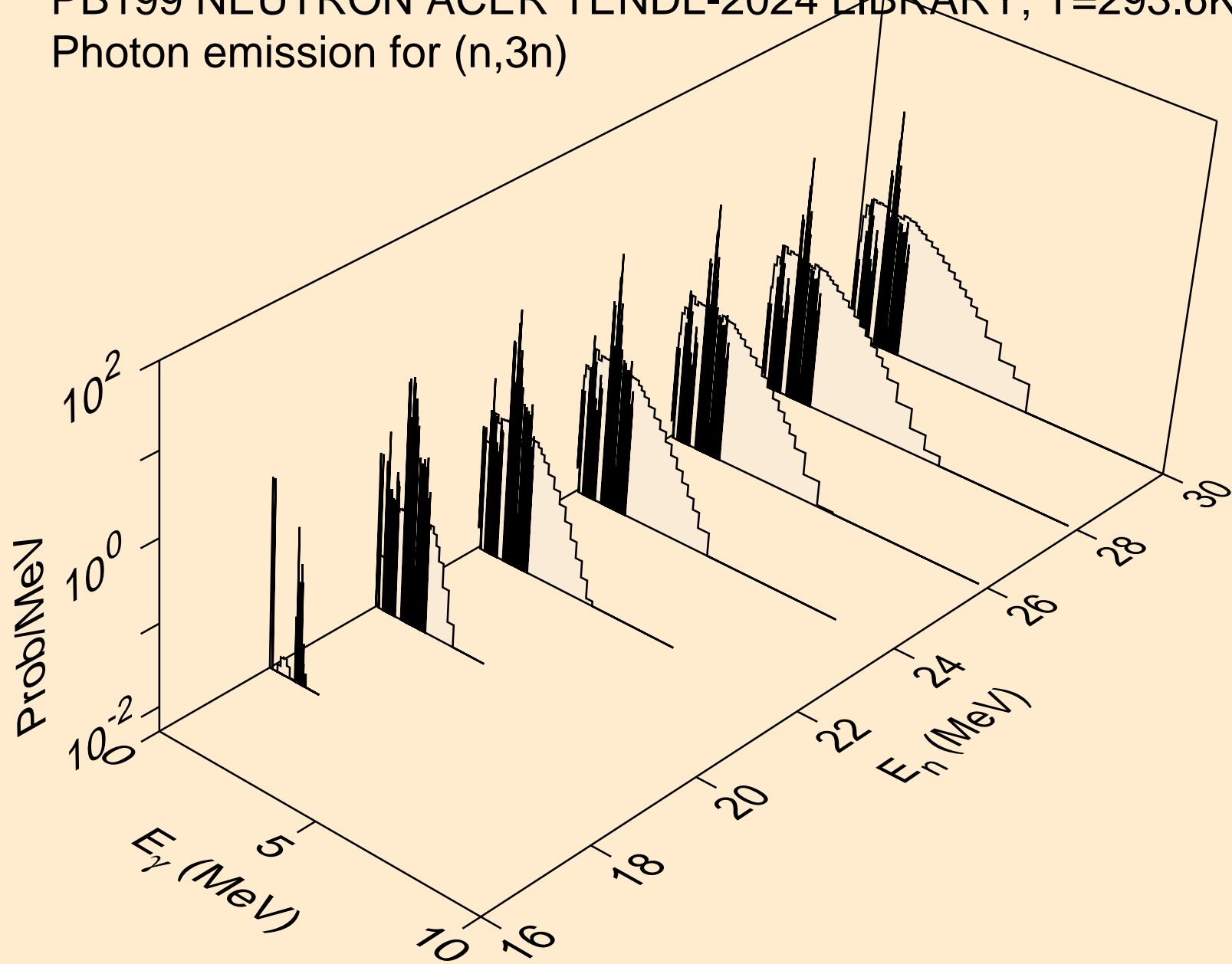

PB199 NEUTRON ACER TENDL-2024 LIBRARY; T=293.6K  
Photon emission for (n,n\*)a

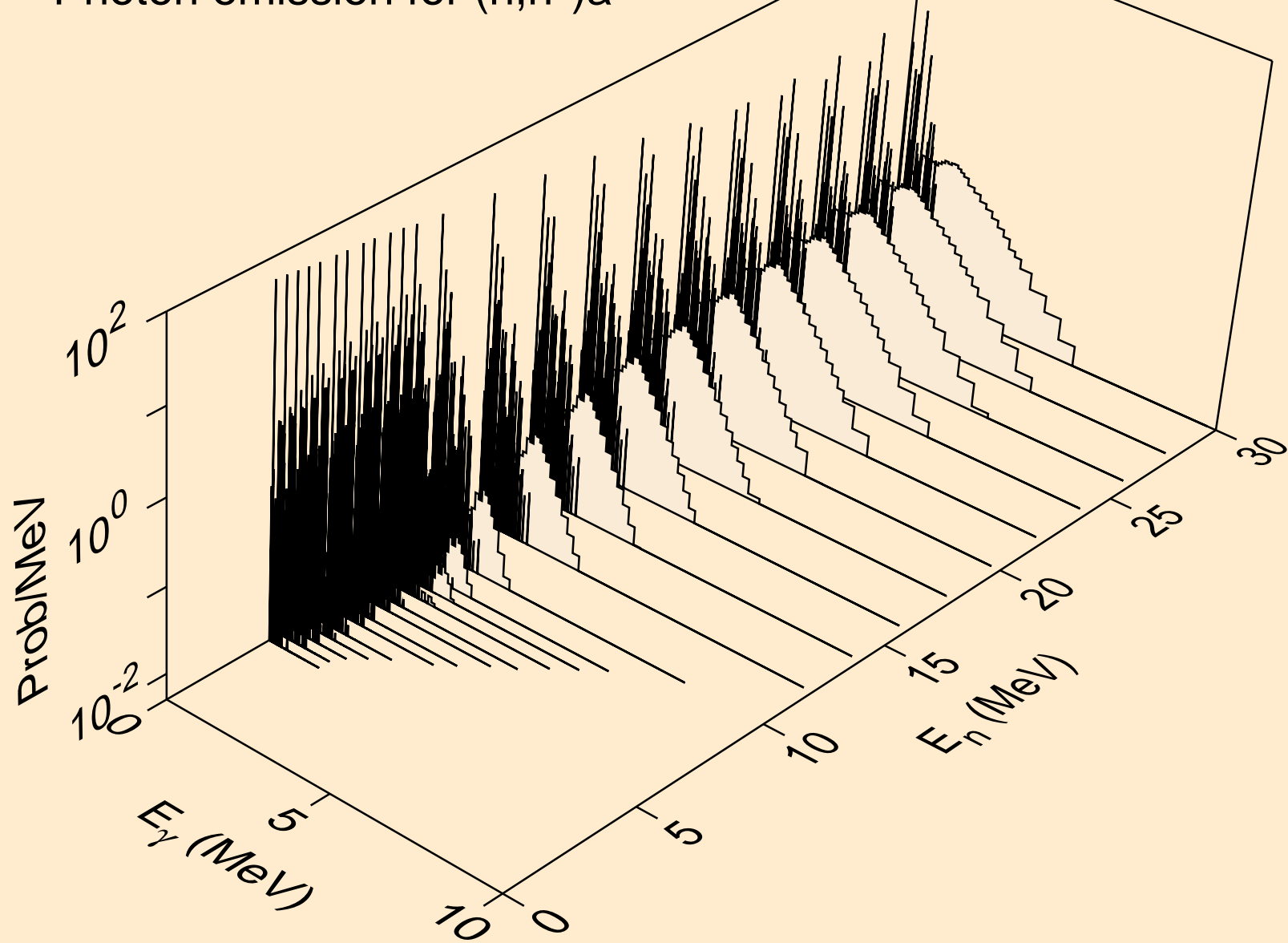

PB199 NEUTRON ACER TENDL-2024 LIBRARY; T=293.6K  
Photon emission for (n,2n)a

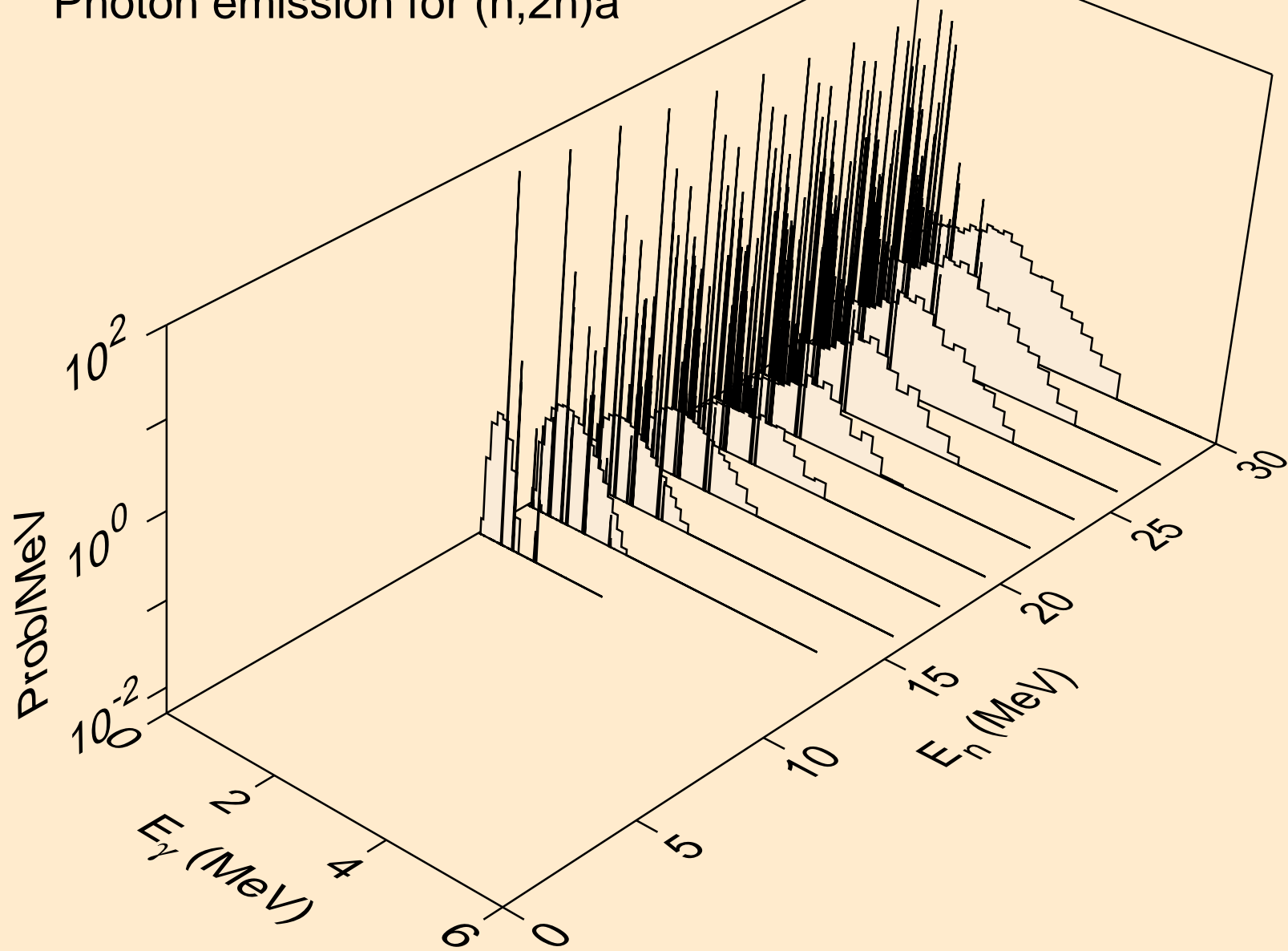

PB199 NEUTRON ACER TENDL-2024 LIBRARY; T=293.6K  
Photon emission for (n,3n)a

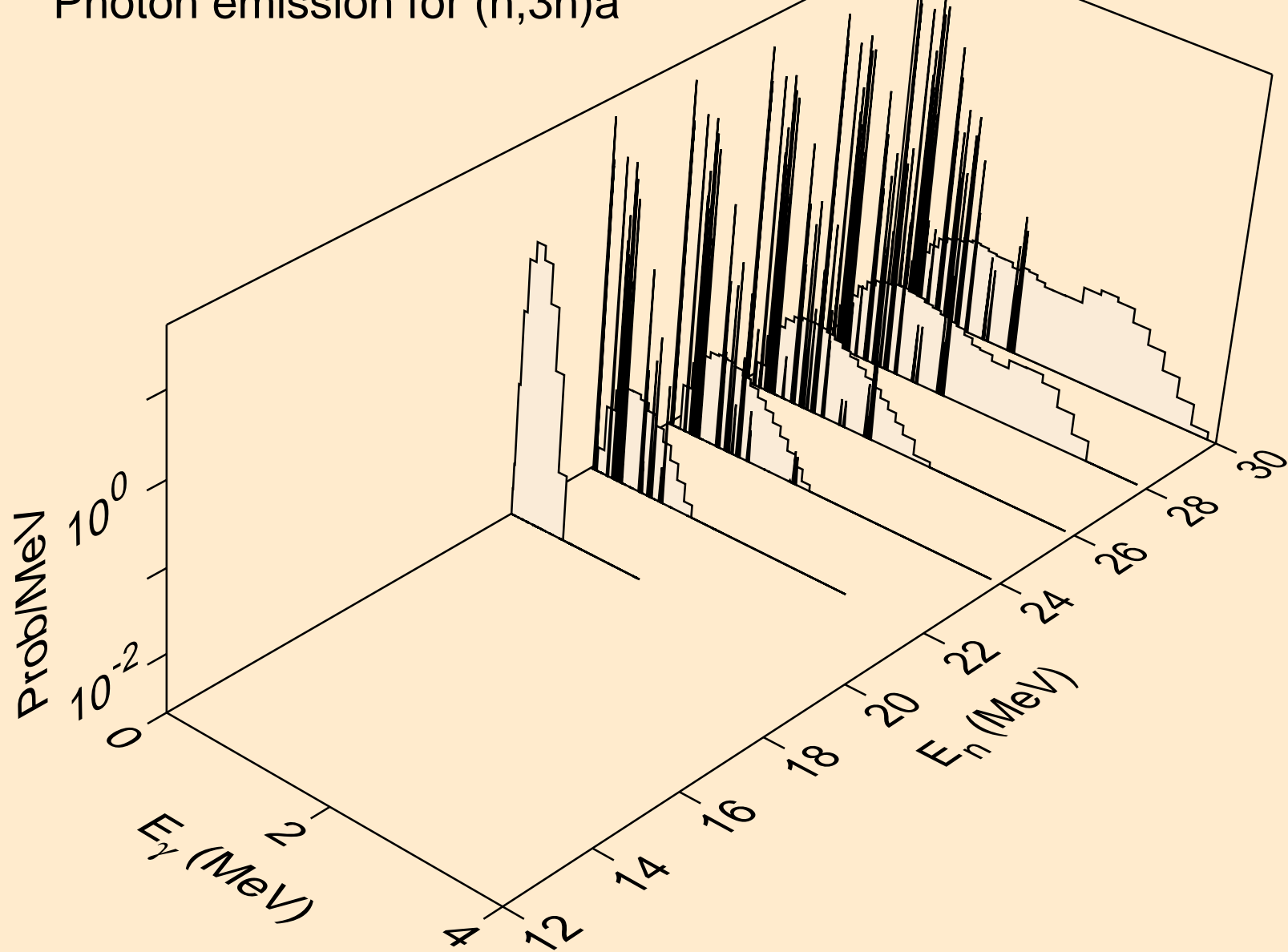

PB199 NEUTRON ACER TENDL-2024 LIBRARY; T=293.6K  
Photon emission for (n,n\*)p

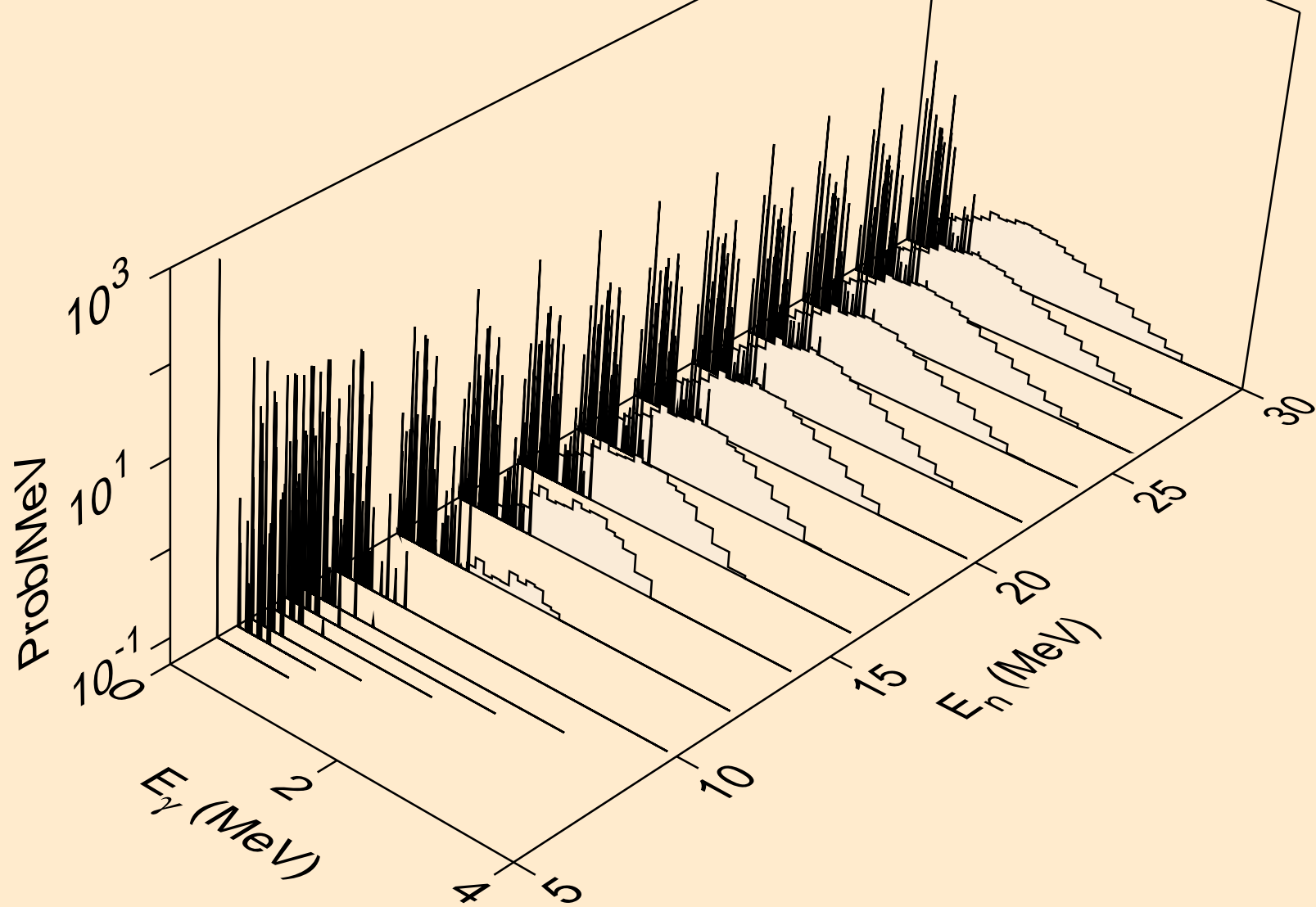

PB199 NEUTRON ACER TENDL-2024 LIBRARY; T=293.6K  
Photon emission for (n,n\*)2a

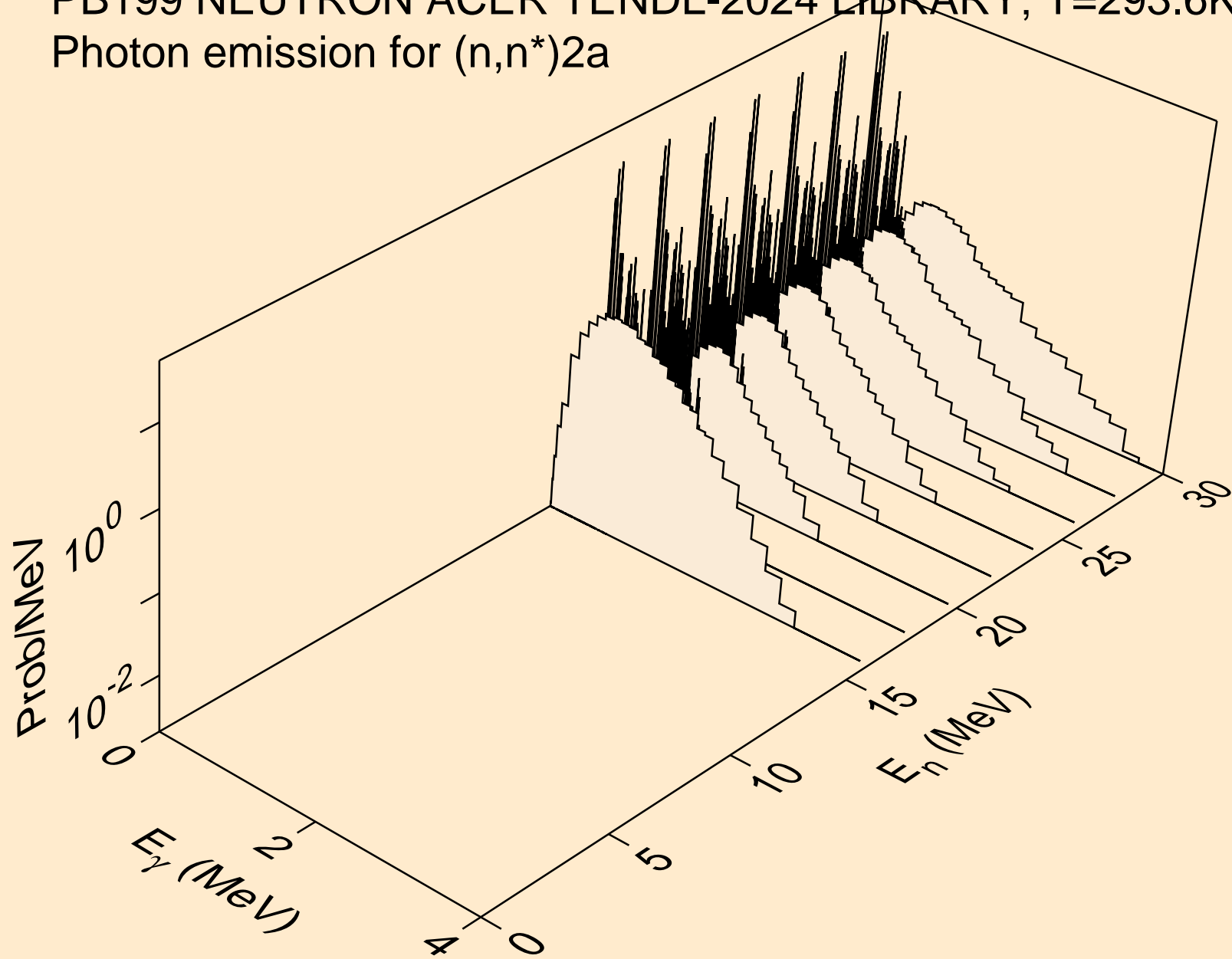

PB199 NEUTRON ACER TENDL-2024 LIBRARY; T=293.6K  
Photon emission for (n,n\*)d

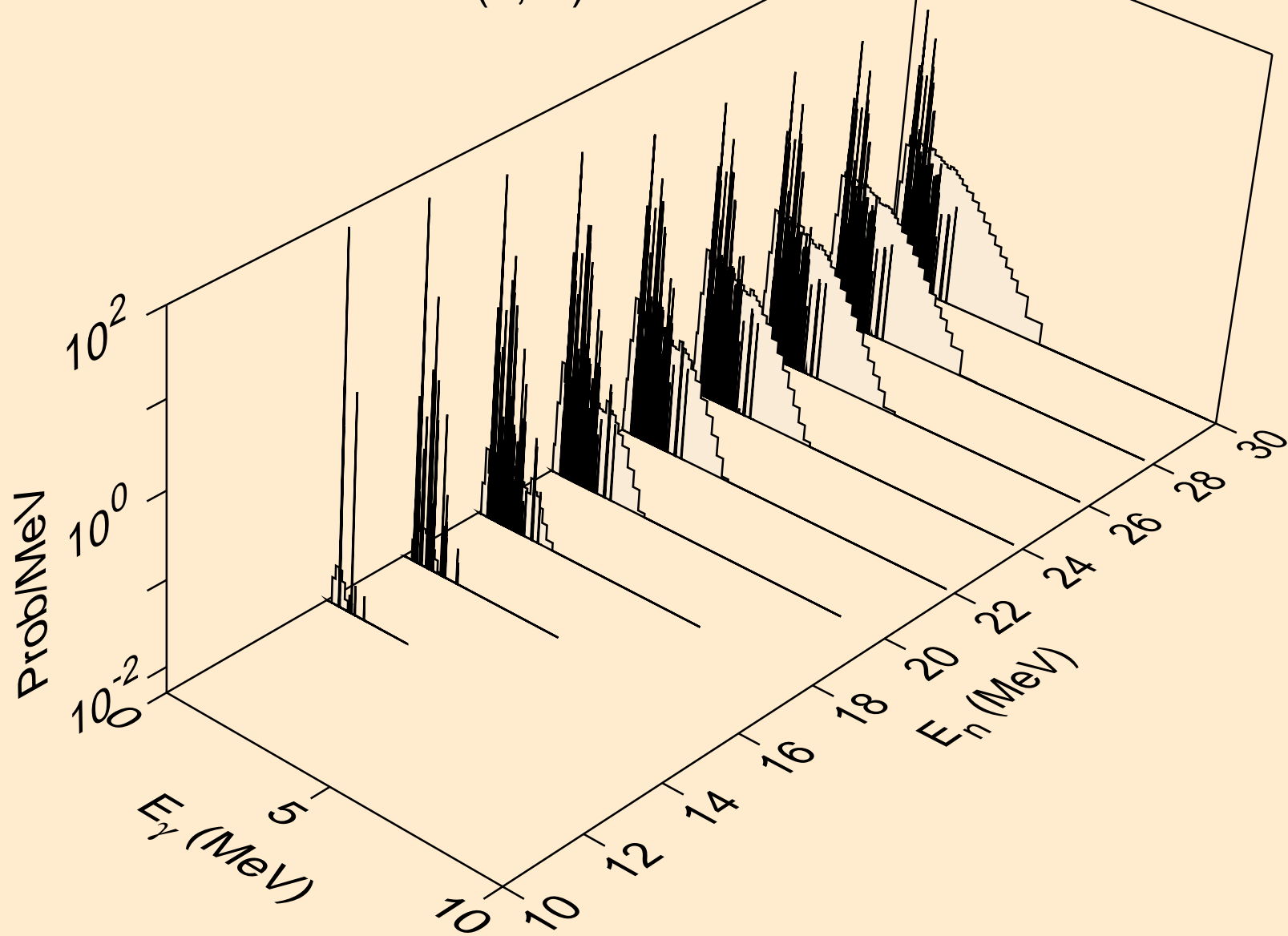

PB199 NEUTRON ACER TENDL-2024 LIBRARY; T=293.6K  
Photon emission for (n,n\*)t

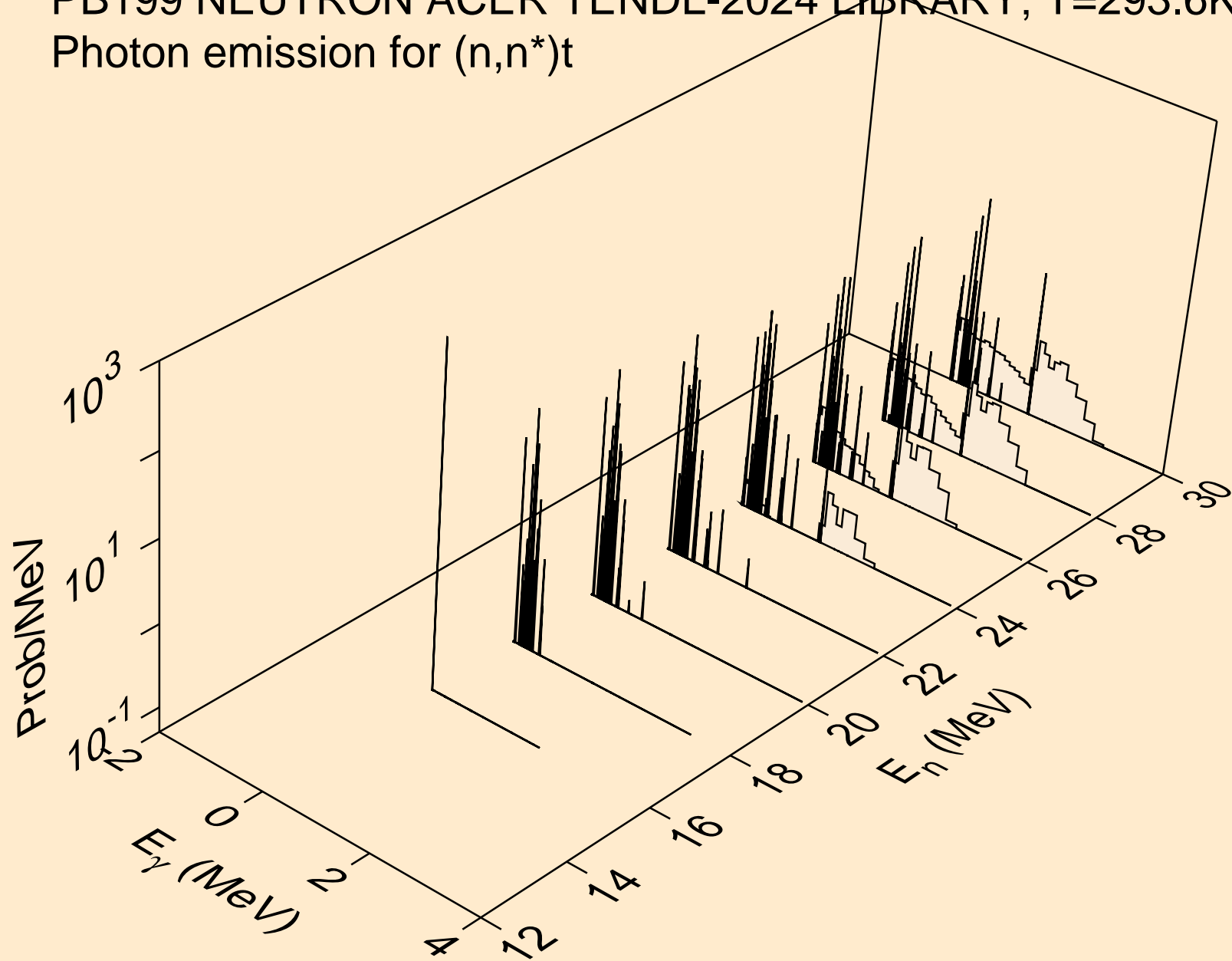

PB199 NEUTRON ACER TENDL-2024 LIBRARY; T=293.6K  
Photon emission for (n,n\*)he3

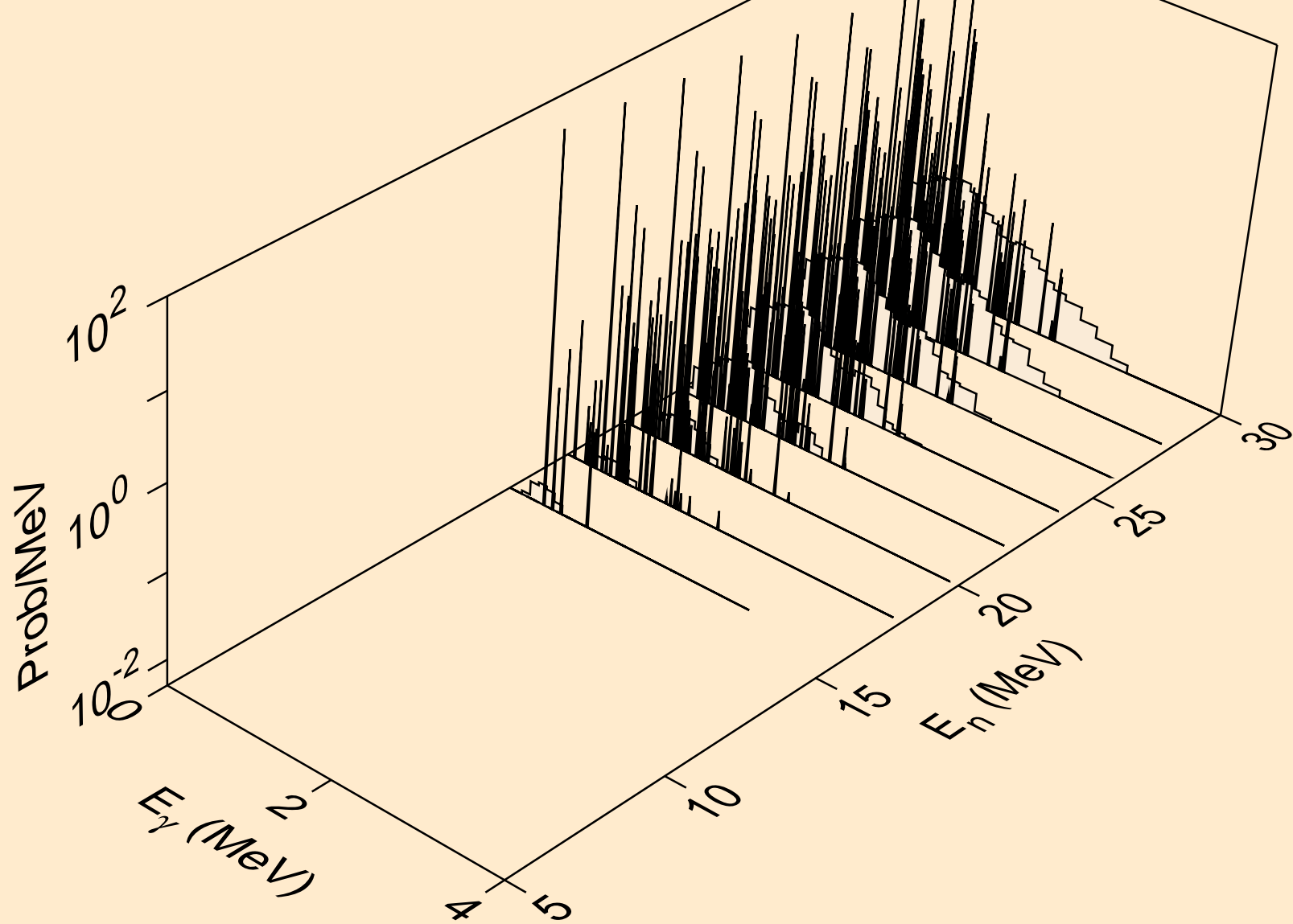

PB199 NEUTRON ACER TENDL-2024 LIBRARY; T=293.6K  
Photon emission for (n,4n)

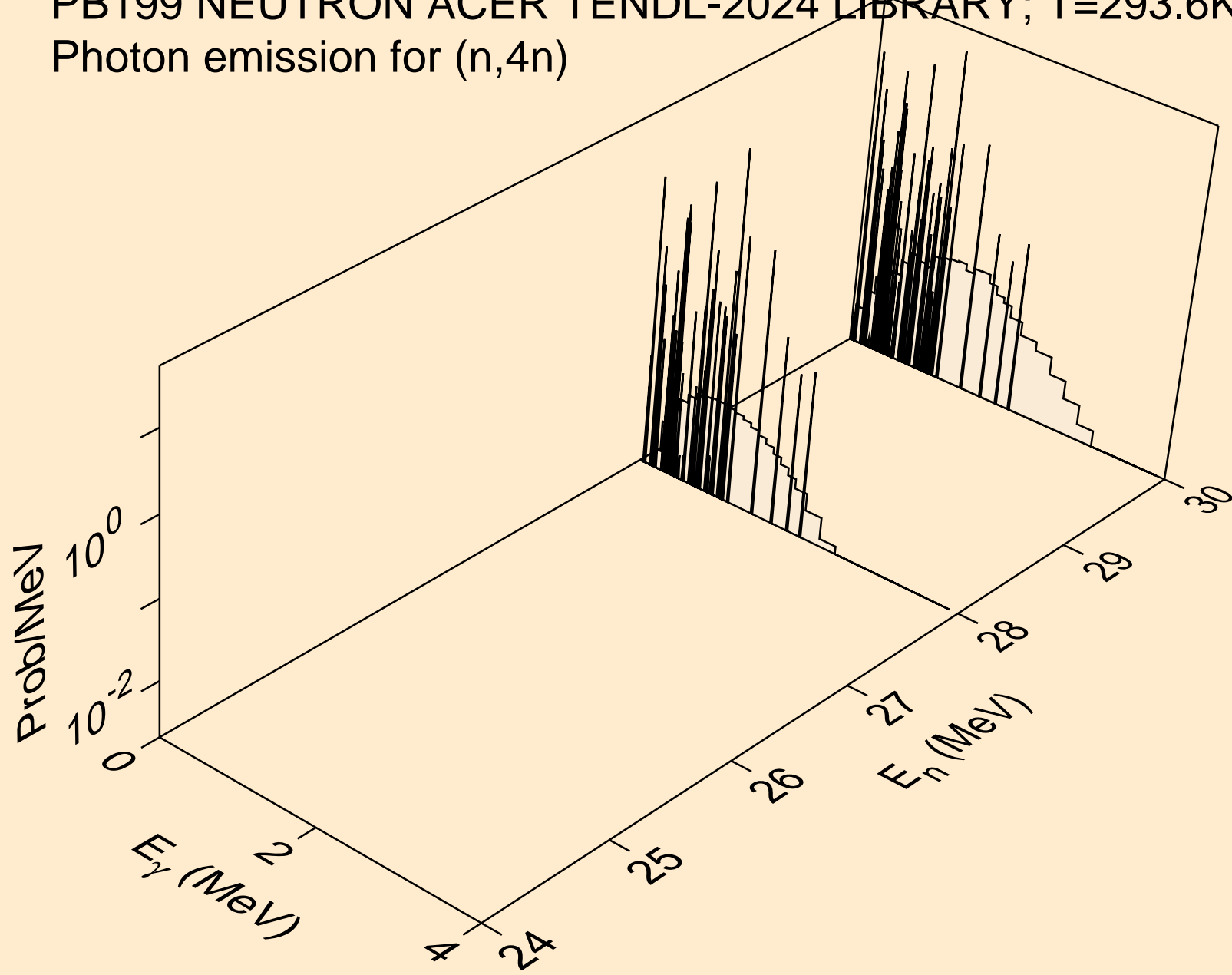

PB199 NEUTRON ACER TENDL-2024 LIBRARY; T=293.6K  
Photon emission for (n,2np)

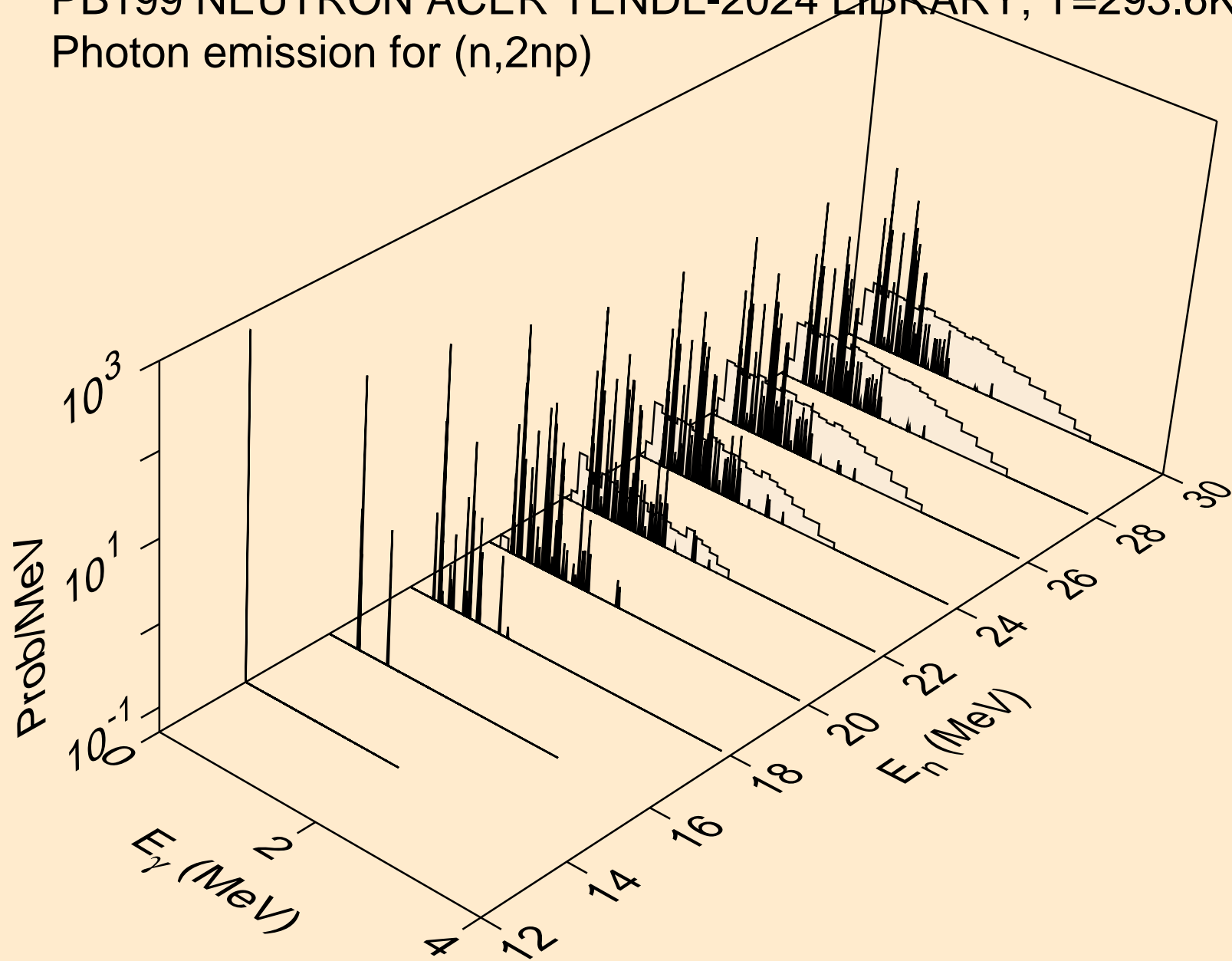

PB199 NEUTRON ACER TENDL-2024 LIBRARY; T=293.6K  
Photon emission for (n,3np)

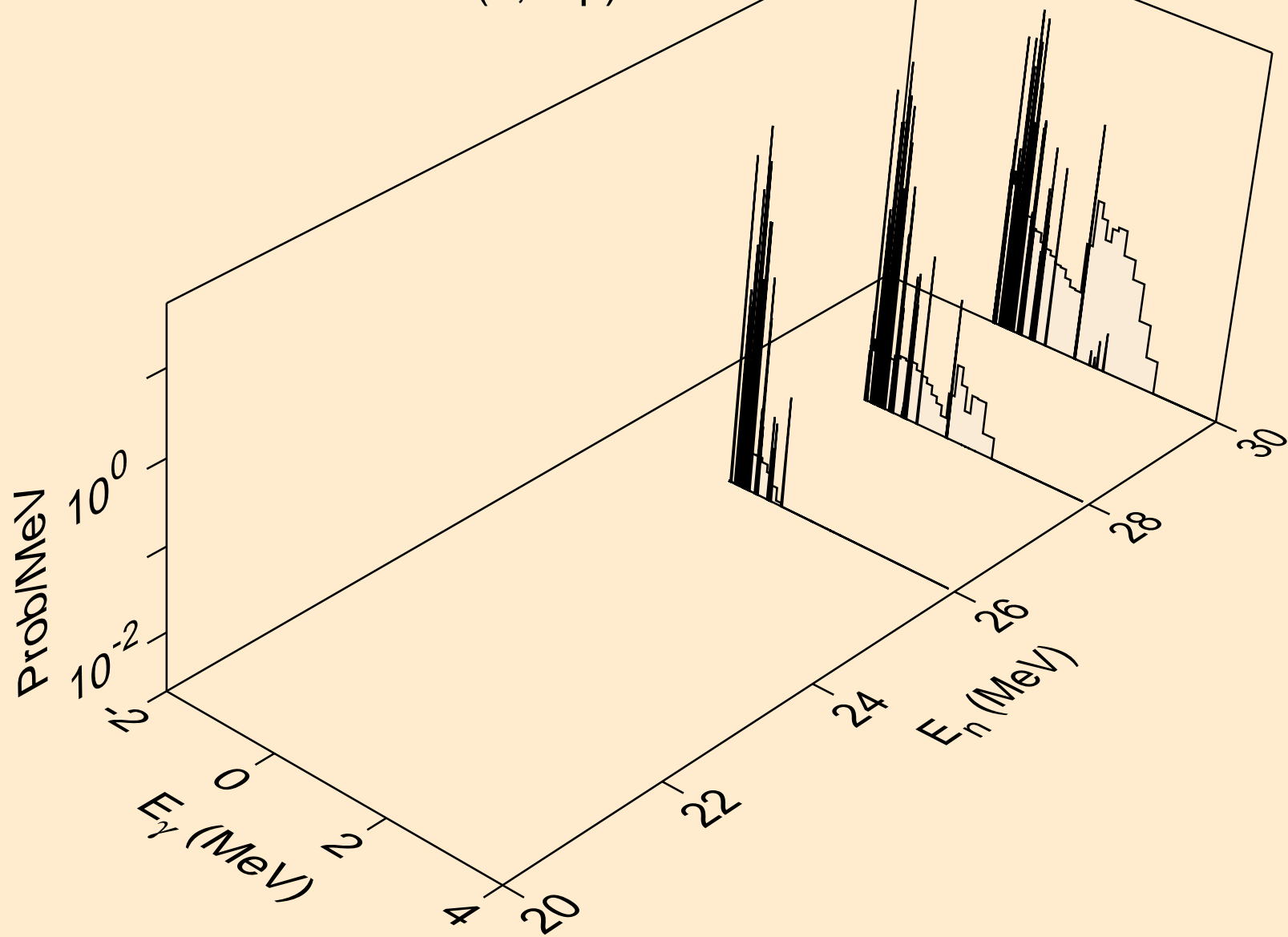

PB199 NEUTRON ACER TENDL-2024 LIBRARY; T=293.6K  
Photon emission for (n,n2p)

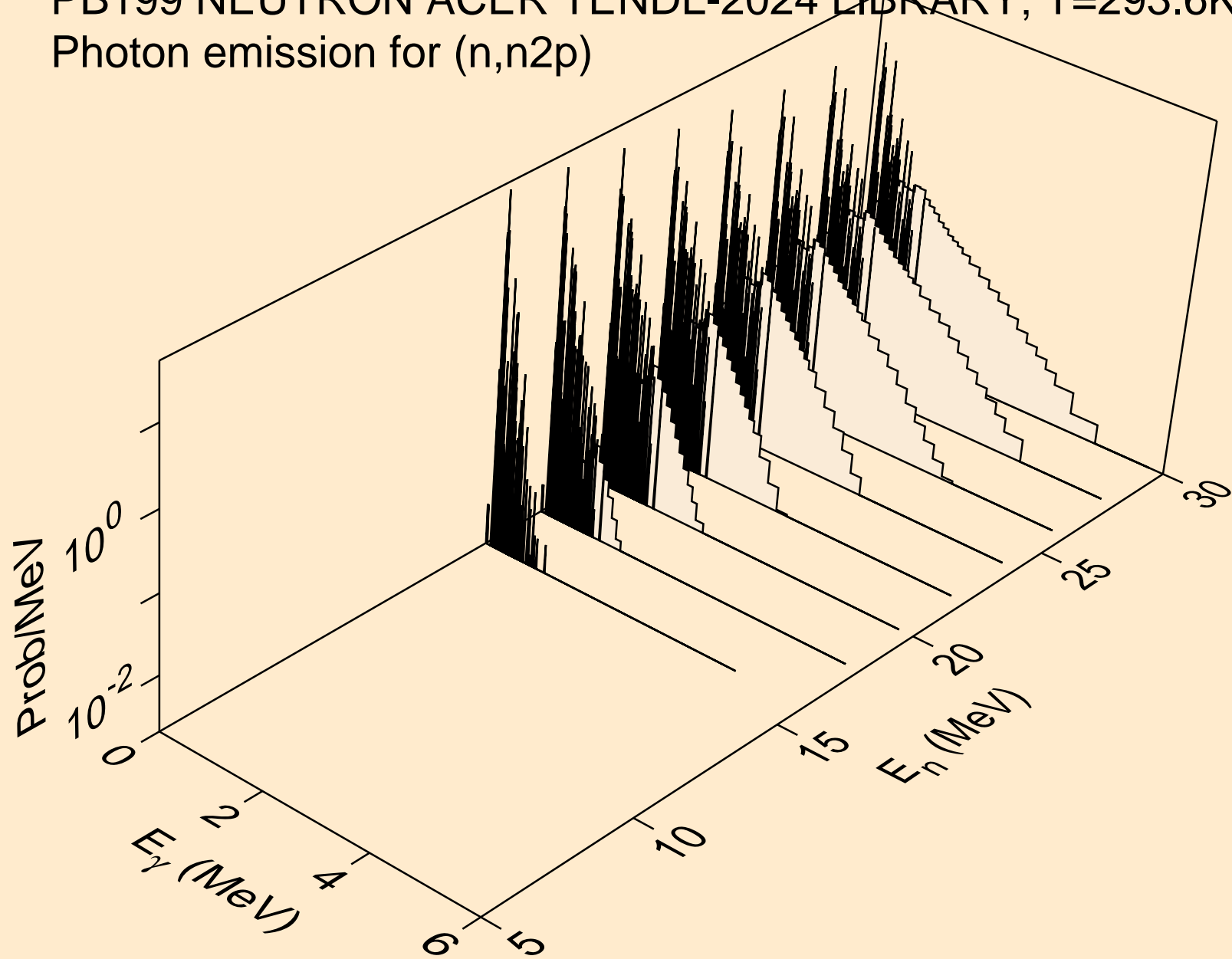

PB199 NEUTRON ACER TENDL-2024 LIBRARY; T=293.6K  
Photon emission for (n,npa)

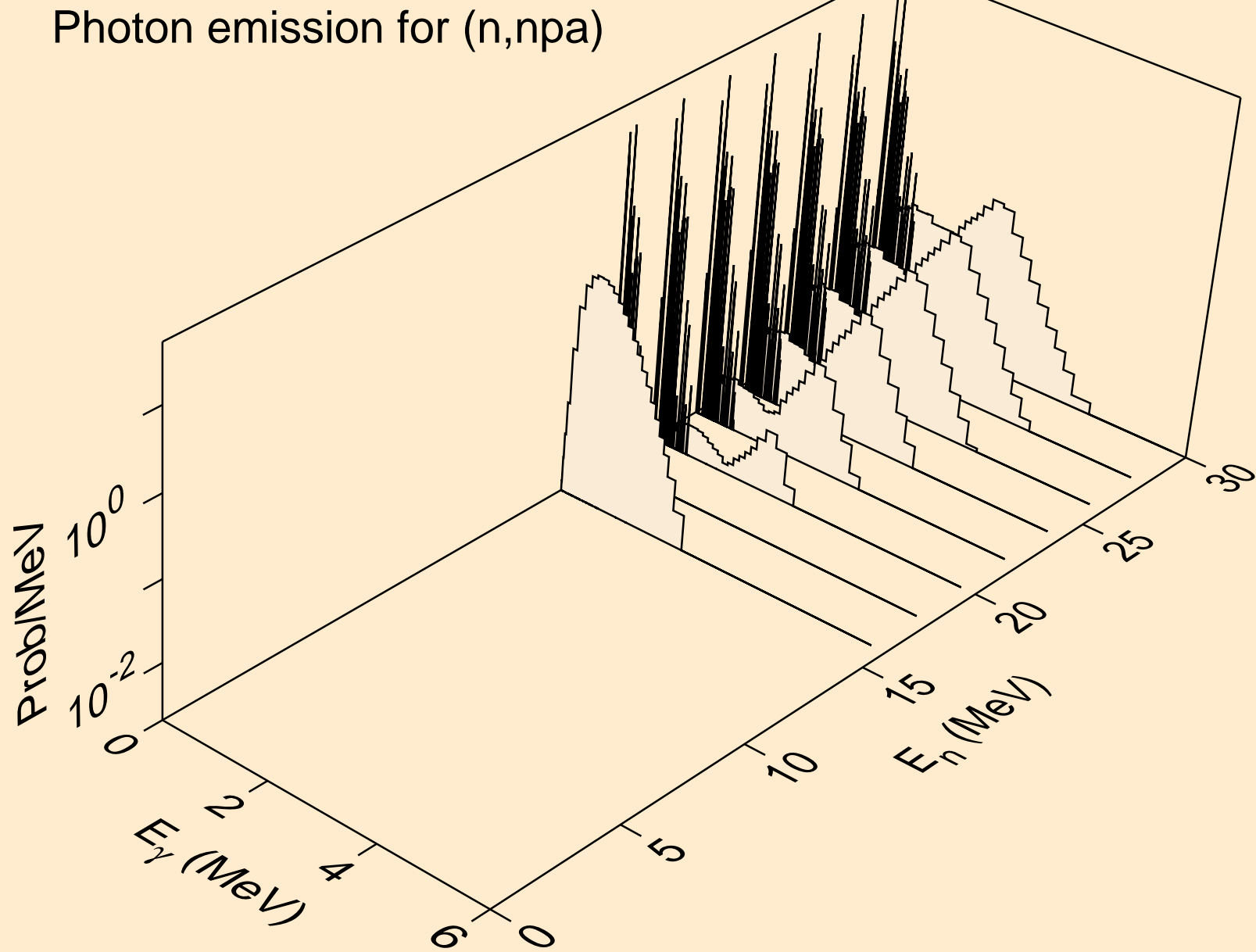

PB199 NEUTRON ACER TENDL-2024 LIBRARY; T=293.6K  
Photon emission for (n,n\*c)

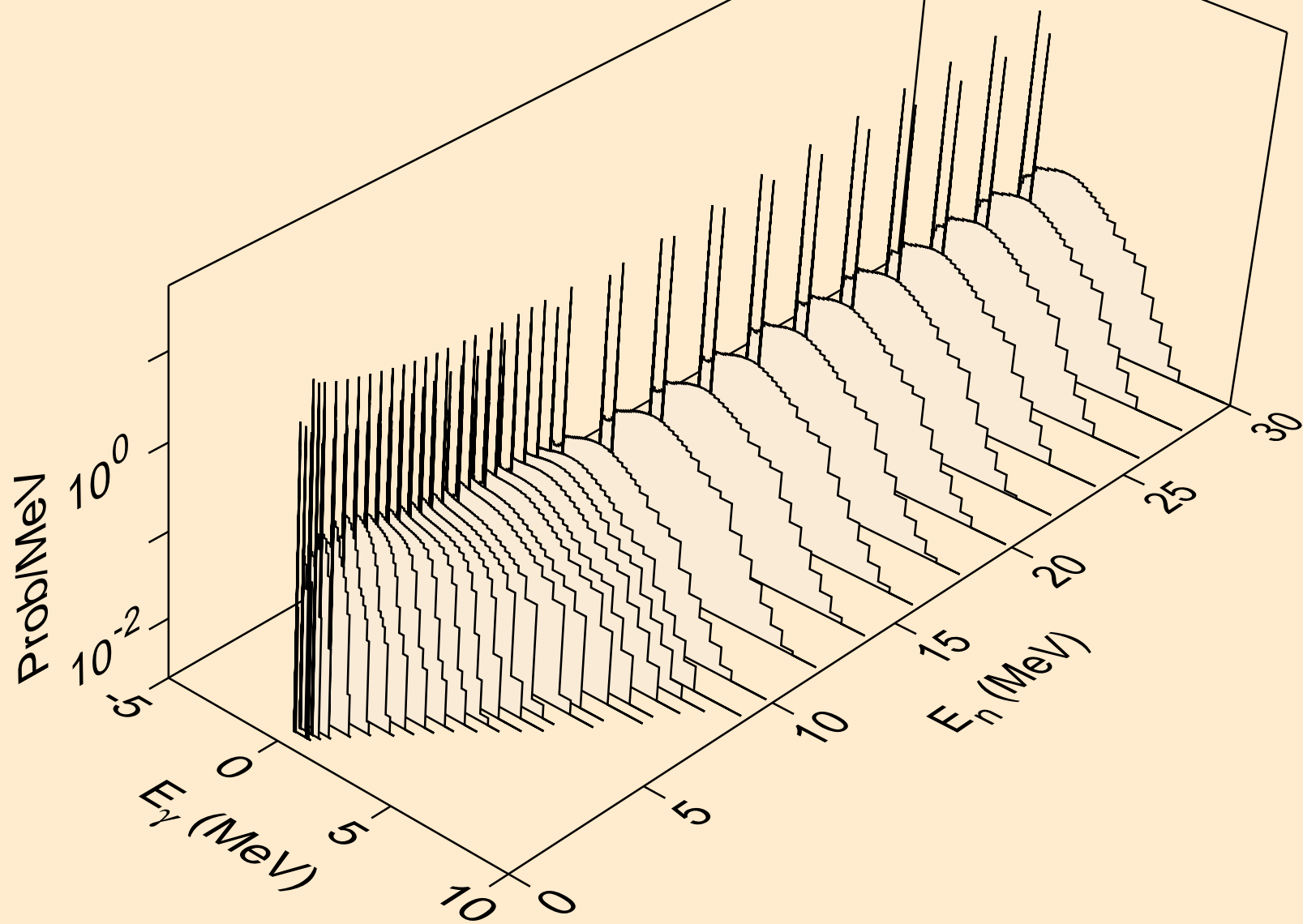

PB199 NEUTRON ACER TENDL-2024 LIBRARY; T=293.6K  
Photon emission for (n,gma)

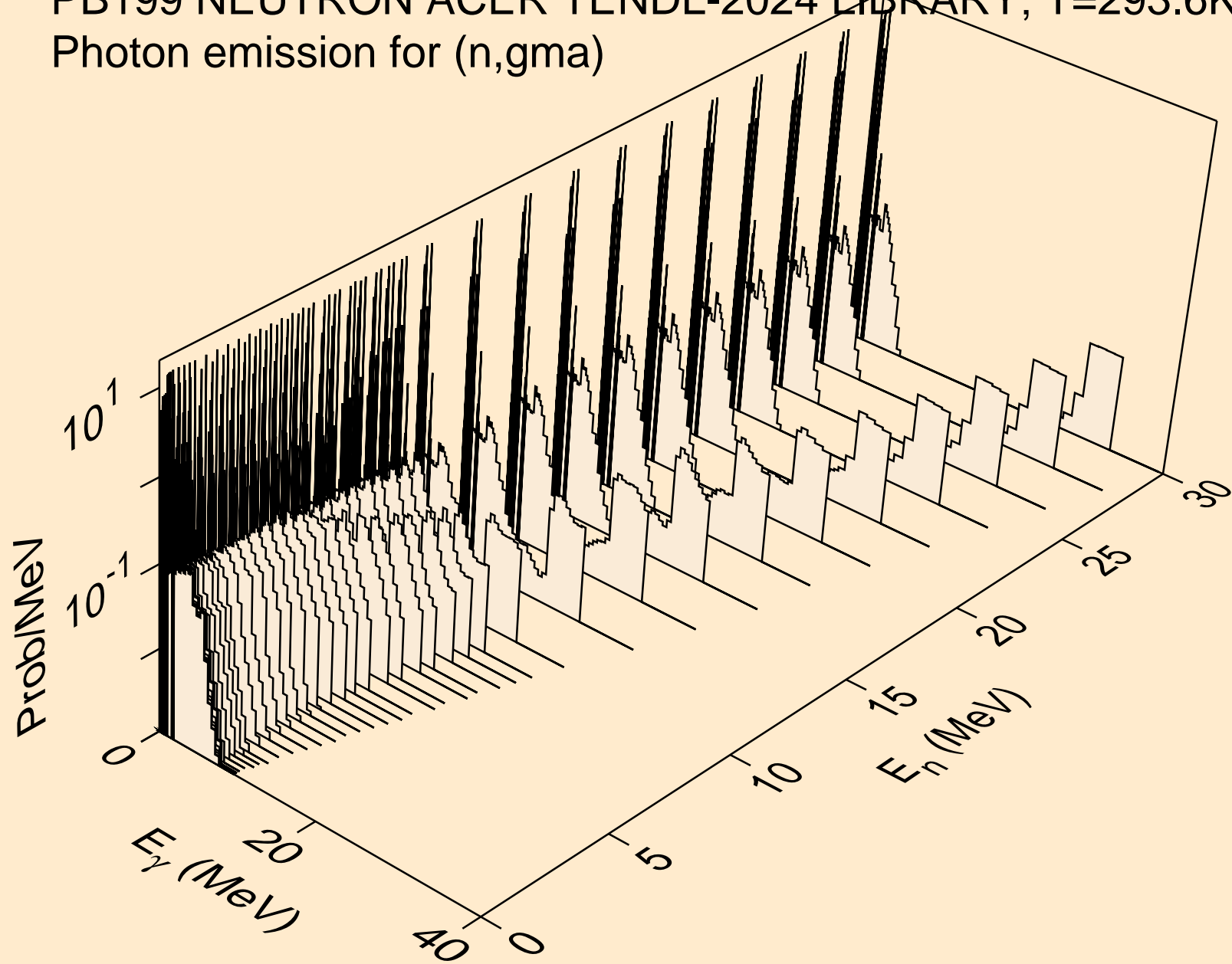

PB199 NEUTRON ACER TENDL-2024 LIBRARY; T=293.6K  
Photon emission for (n,p)

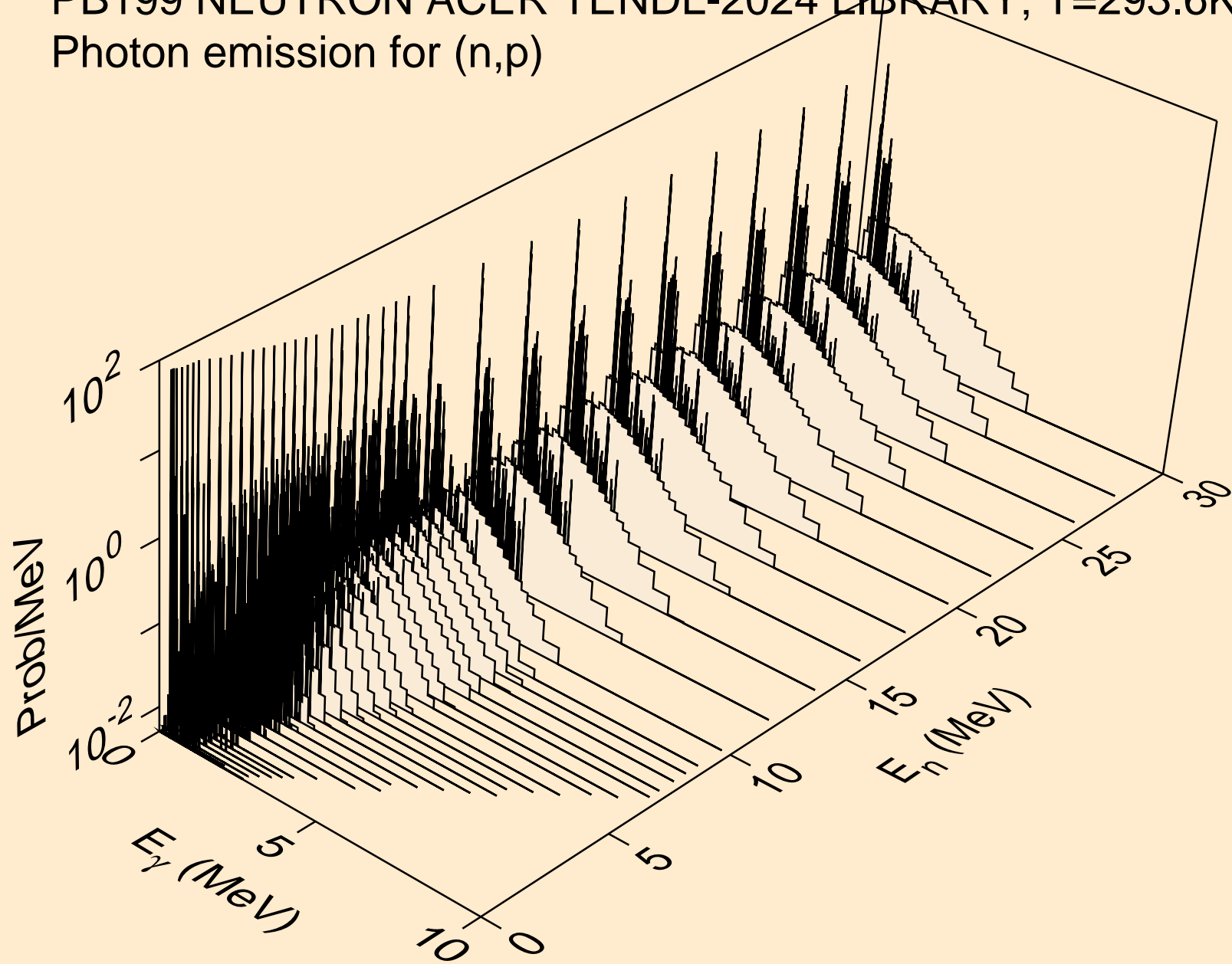

PB199 NEUTRON ACER TENDL-2024 LIBRARY; T=293.6K  
Photon emission for (n,d)

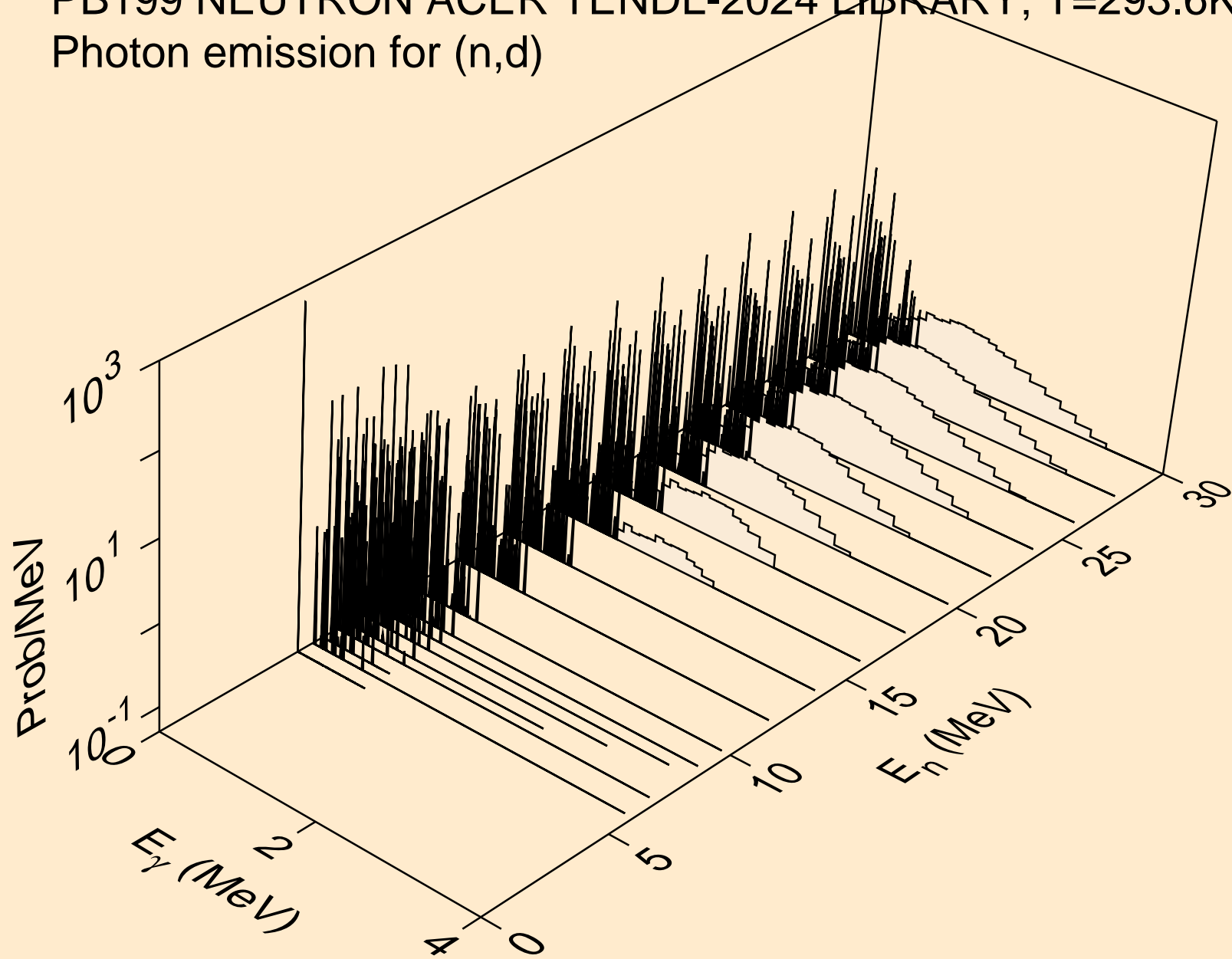

PB199 NEUTRON ACER TENDL-2024 LIBRARY; T=293.6K  
Photon emission for (n,t)

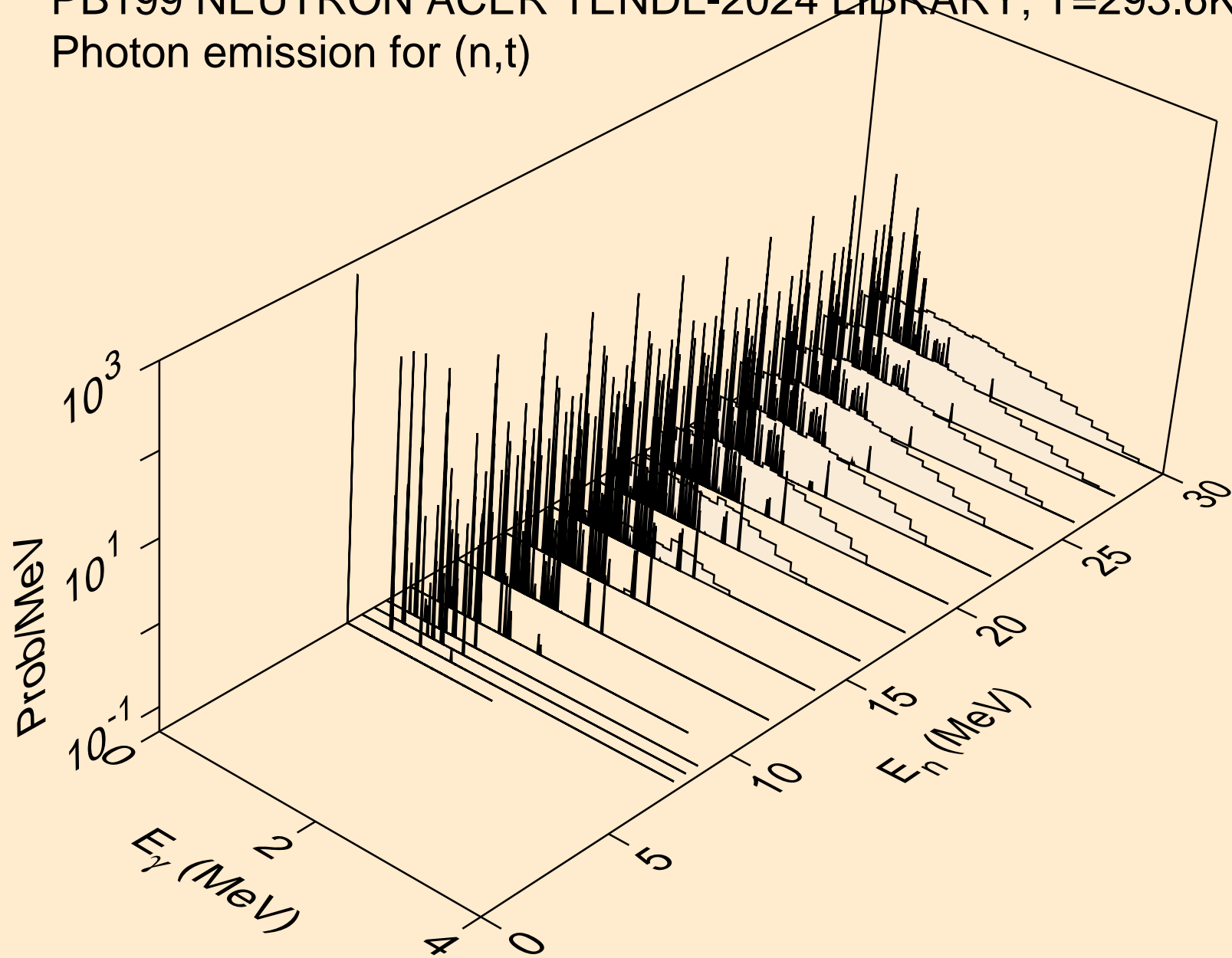

PB199 NEUTRON ACER TENDL-2024 LIBRARY; T=293.6K  
Photon emission for (n,he3)

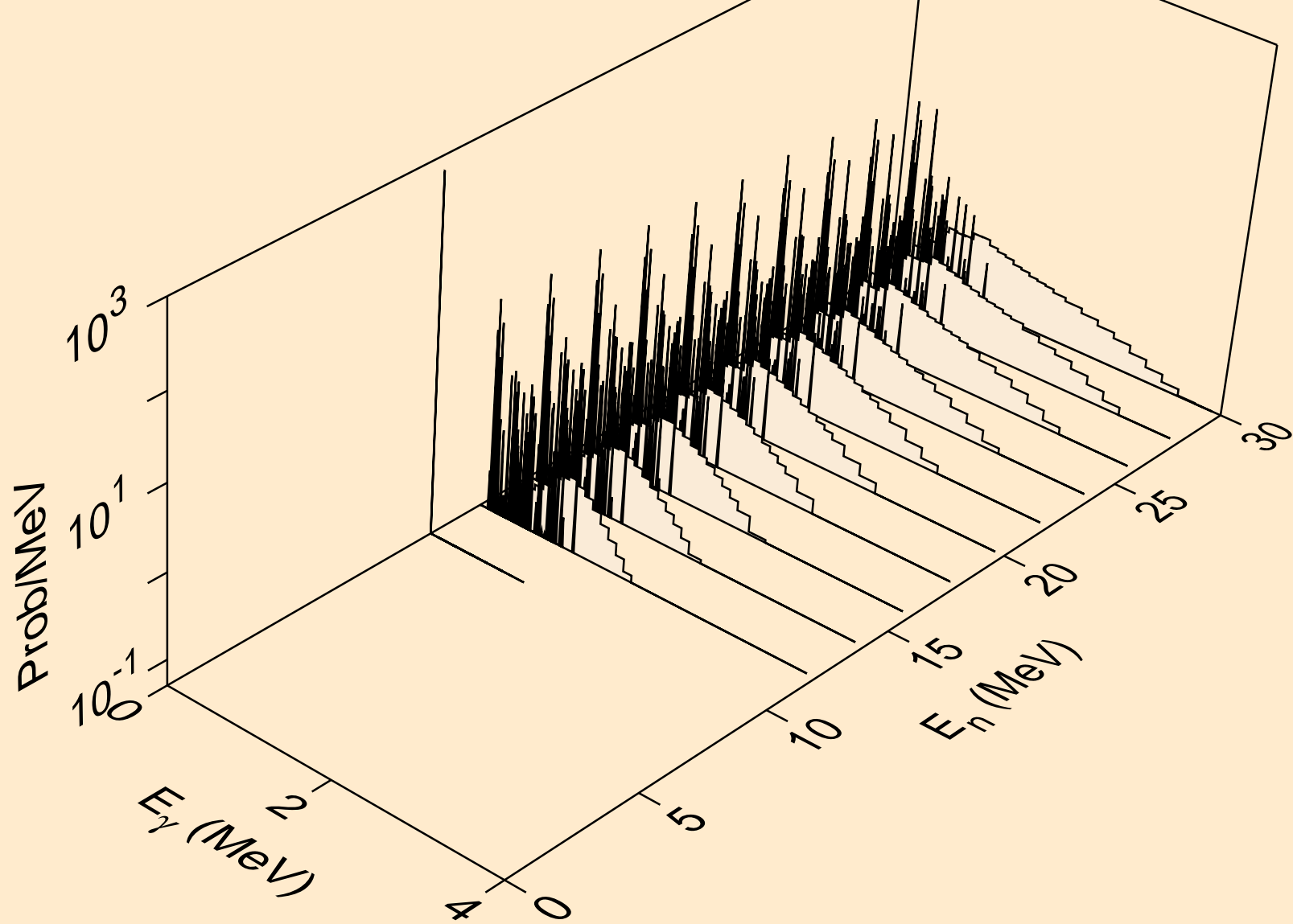

PB199 NEUTRON ACER TENDL-2024 LIBRARY; T=293.6K  
Photon emission for (n,a)

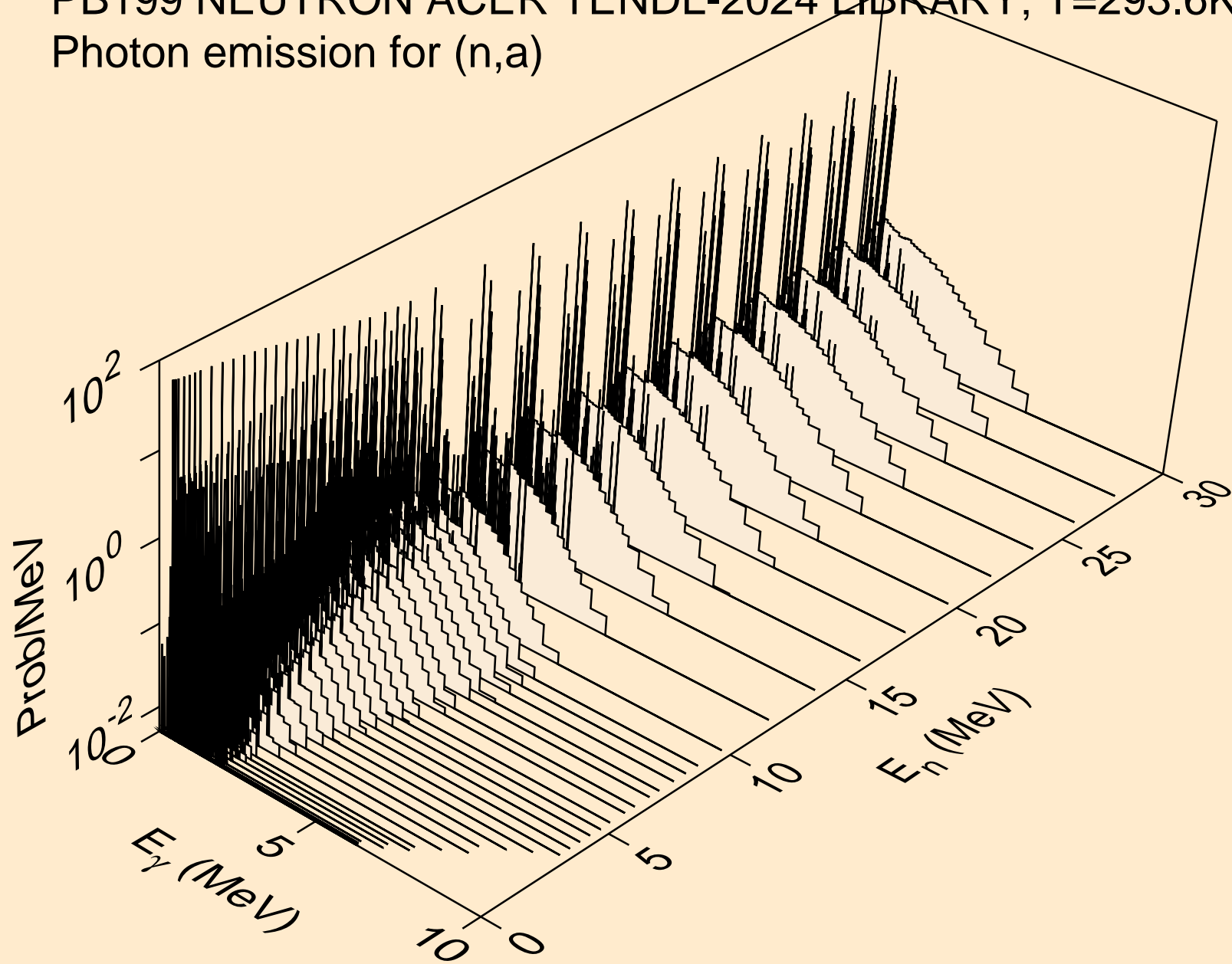

PB199 NEUTRON ACER TENDL-2024 LIBRARY; T=293.6K  
Photon emission for (n,2a)

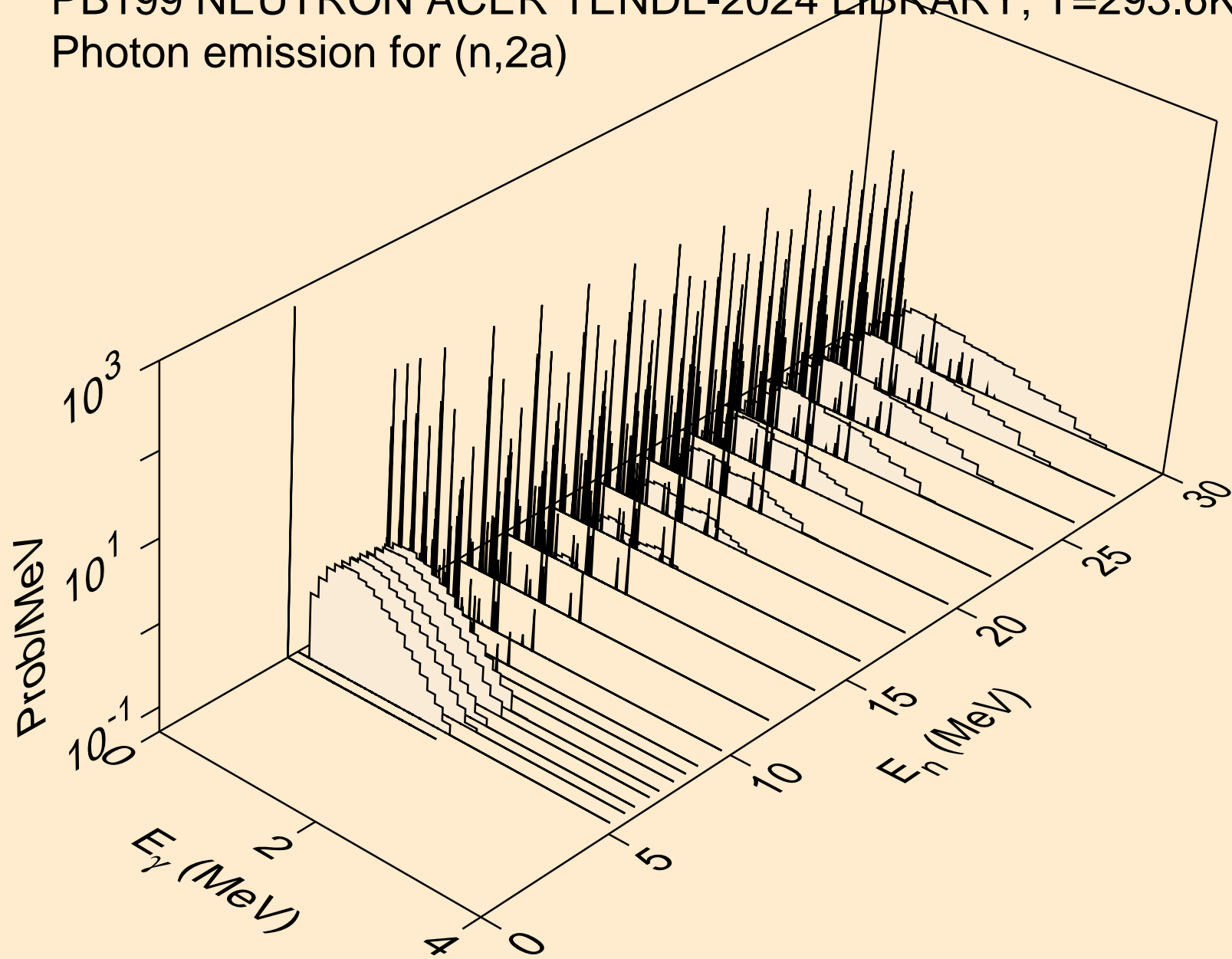

PB199 NEUTRON ACER TENDL-2024 LIBRARY; T=293.6K  
Photon emission for (n,2p)

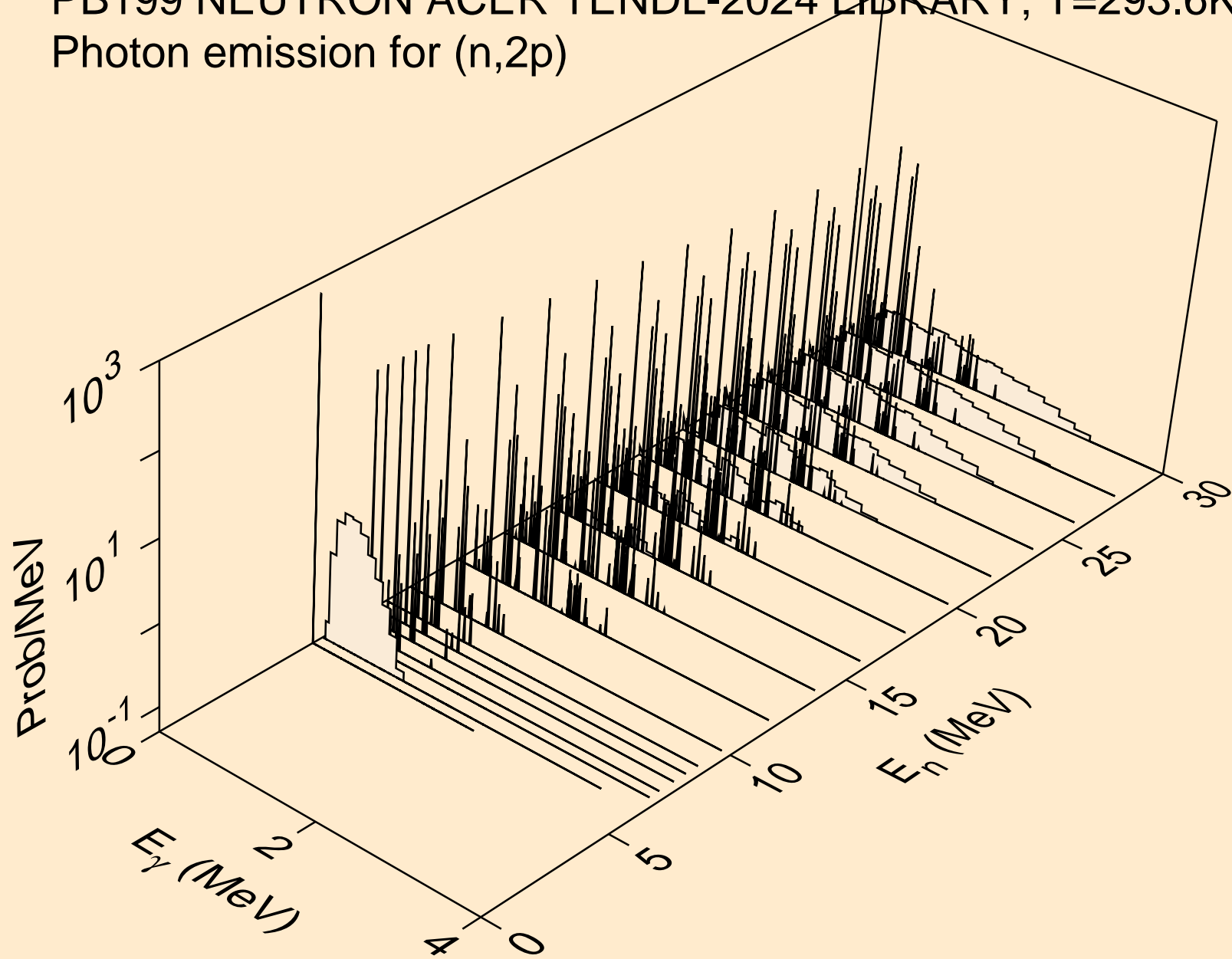

PB199 NEUTRON ACER TENDL-2024 LIBRARY; T=293.6K  
Photon emission for (n,p $\alpha$ )

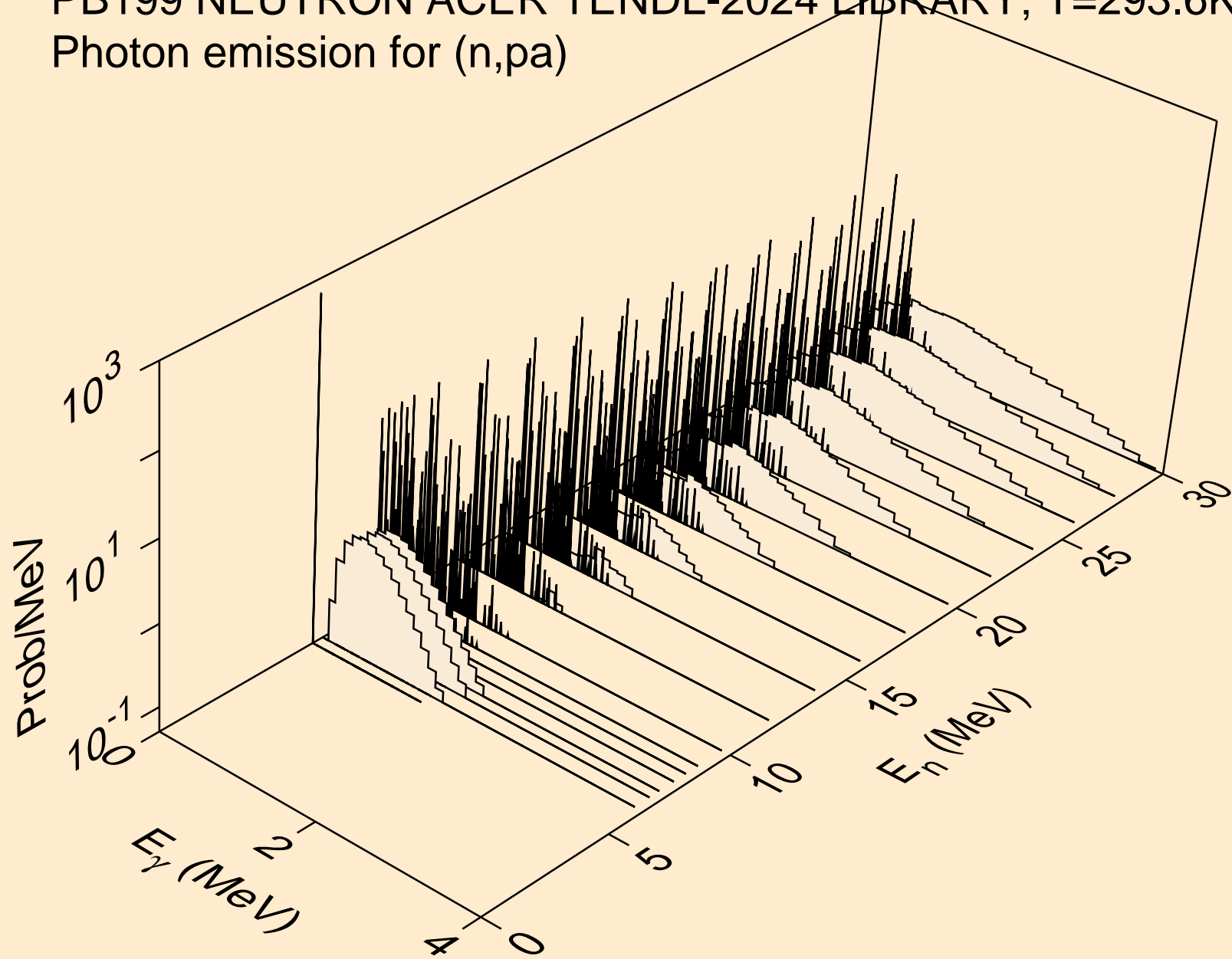

PB199 NEUTRON ACER TENDL-2024 LIBRARY; T=293.6K  
Photon emission for (n,pd)

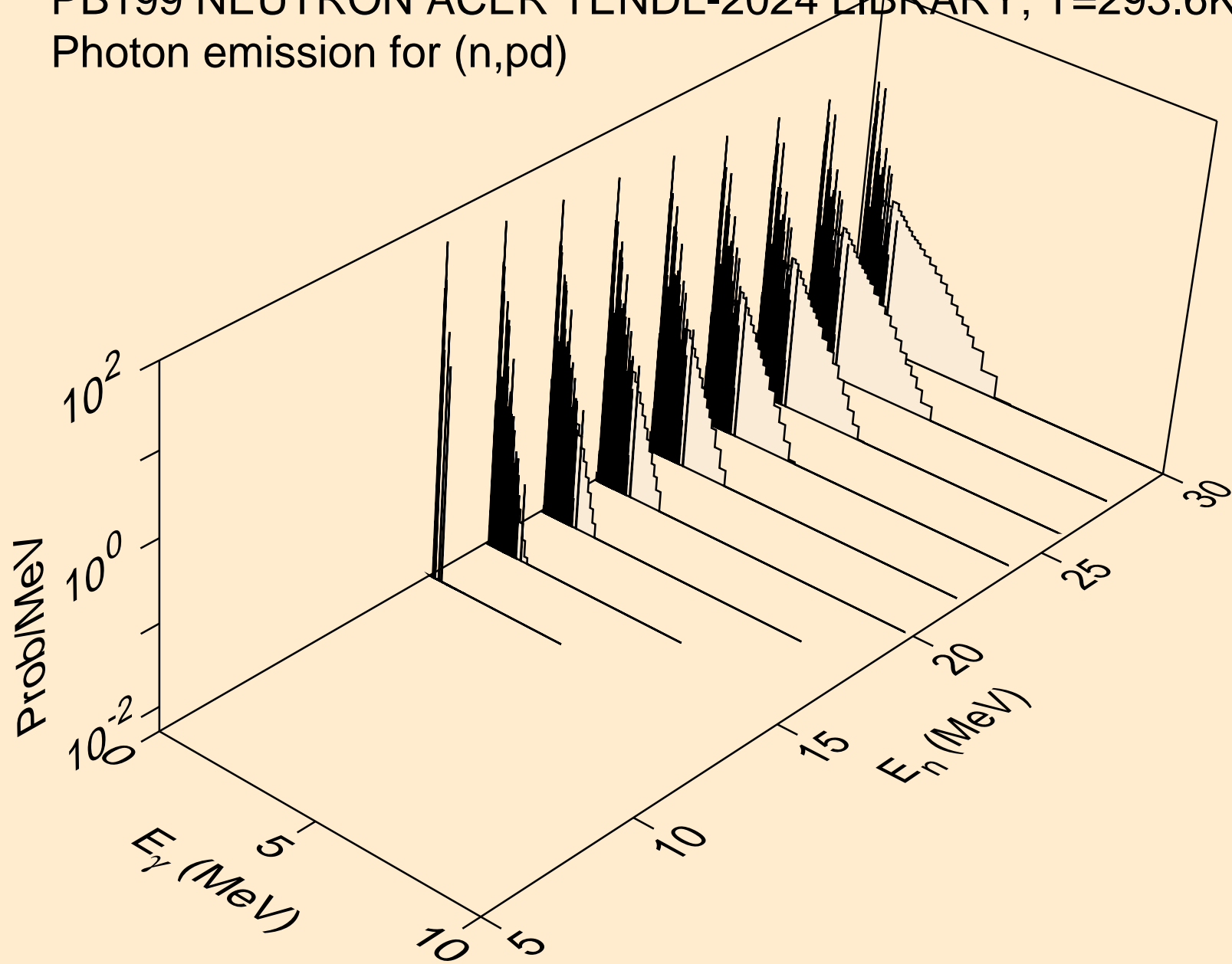

PB199 NEUTRON ACER TENDL-2024 LIBRARY; T=293.6K  
Photon emission for (n,pt)

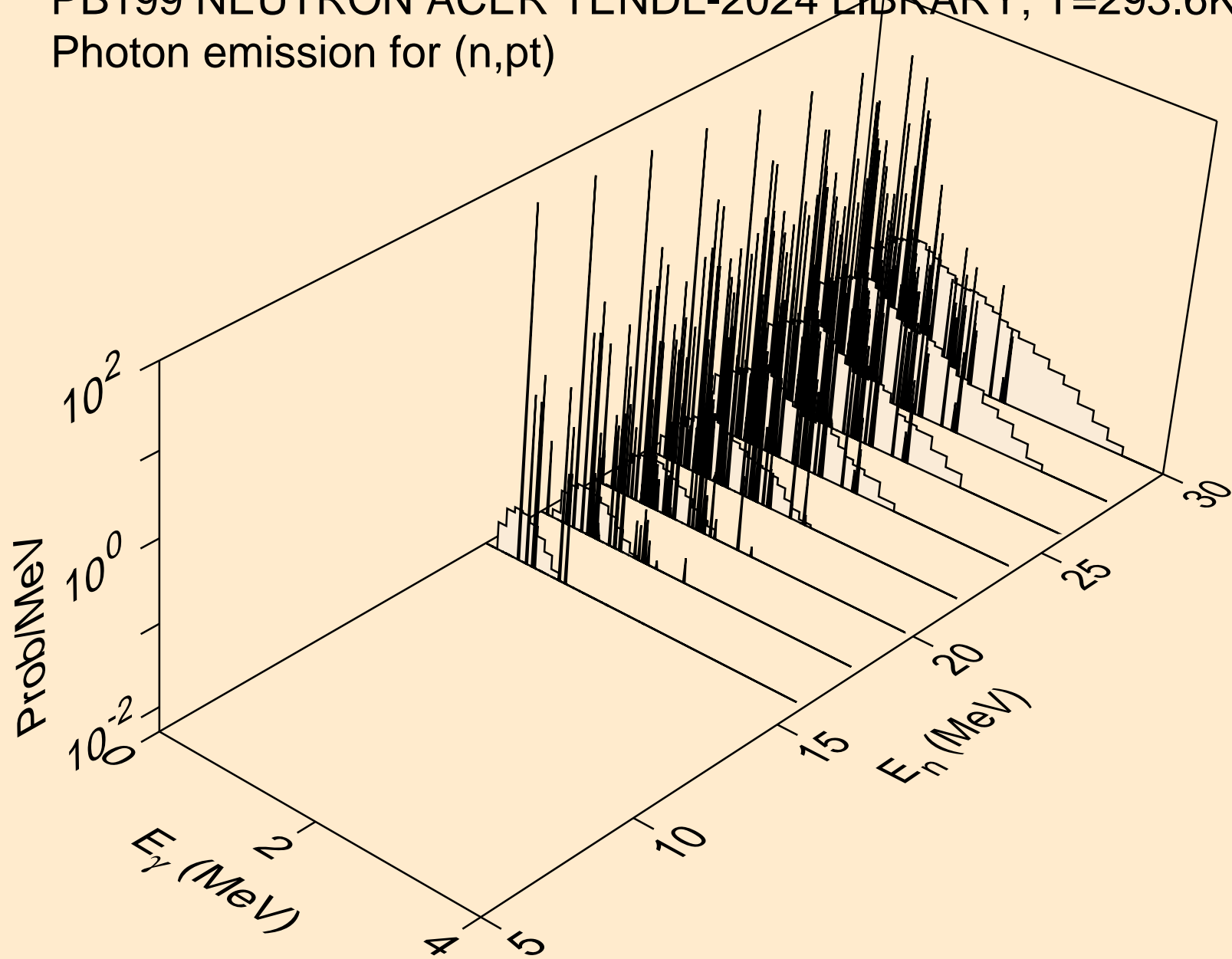

PB199 NEUTRON ACER TENDL-2024 LIBRARY; T=293.6K  
Photon emission for (n,da)

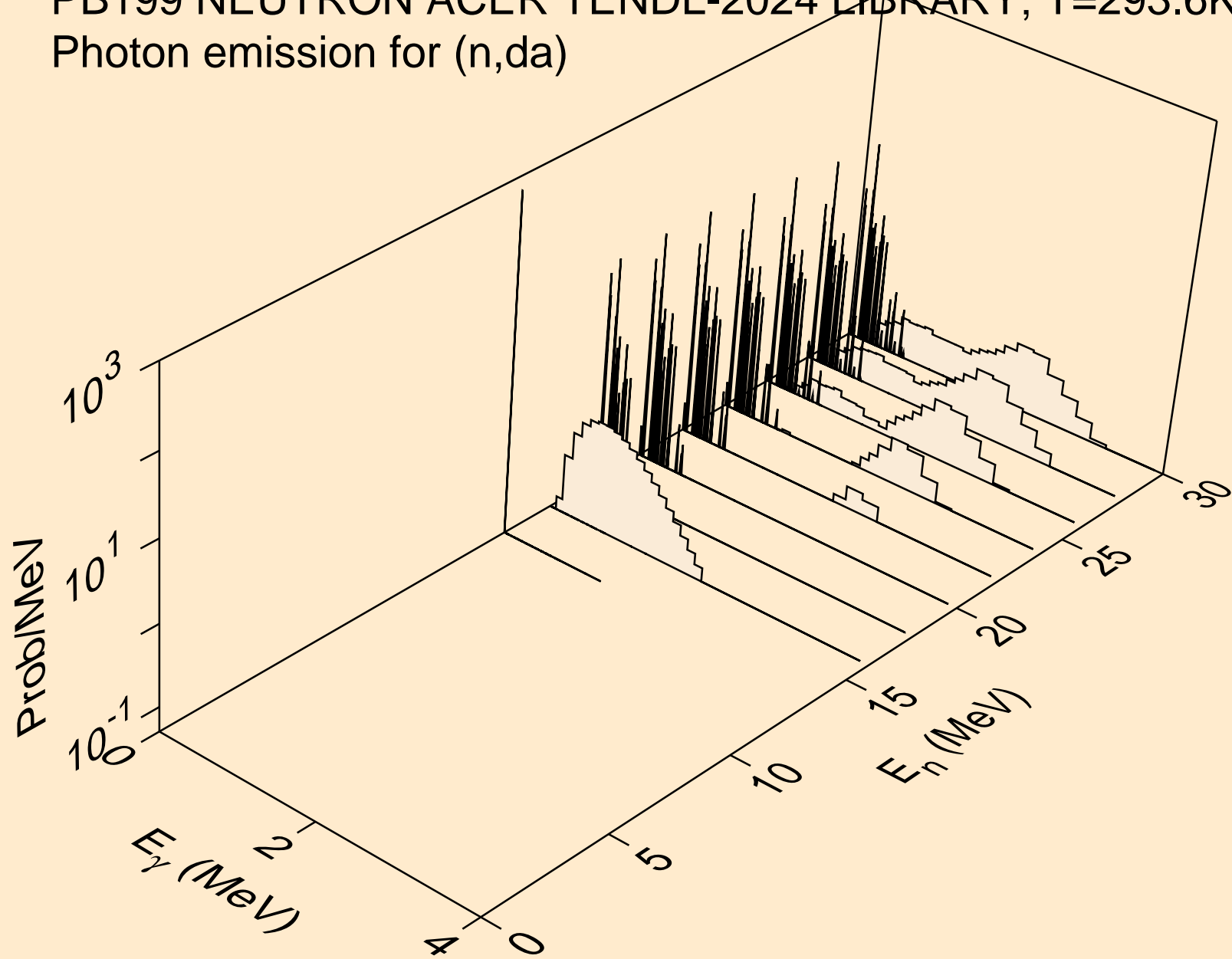

PB199 NEUTRON ACER TENDL-2024 LIBRARY; T=293.6K  
thermal capture photon spectrum

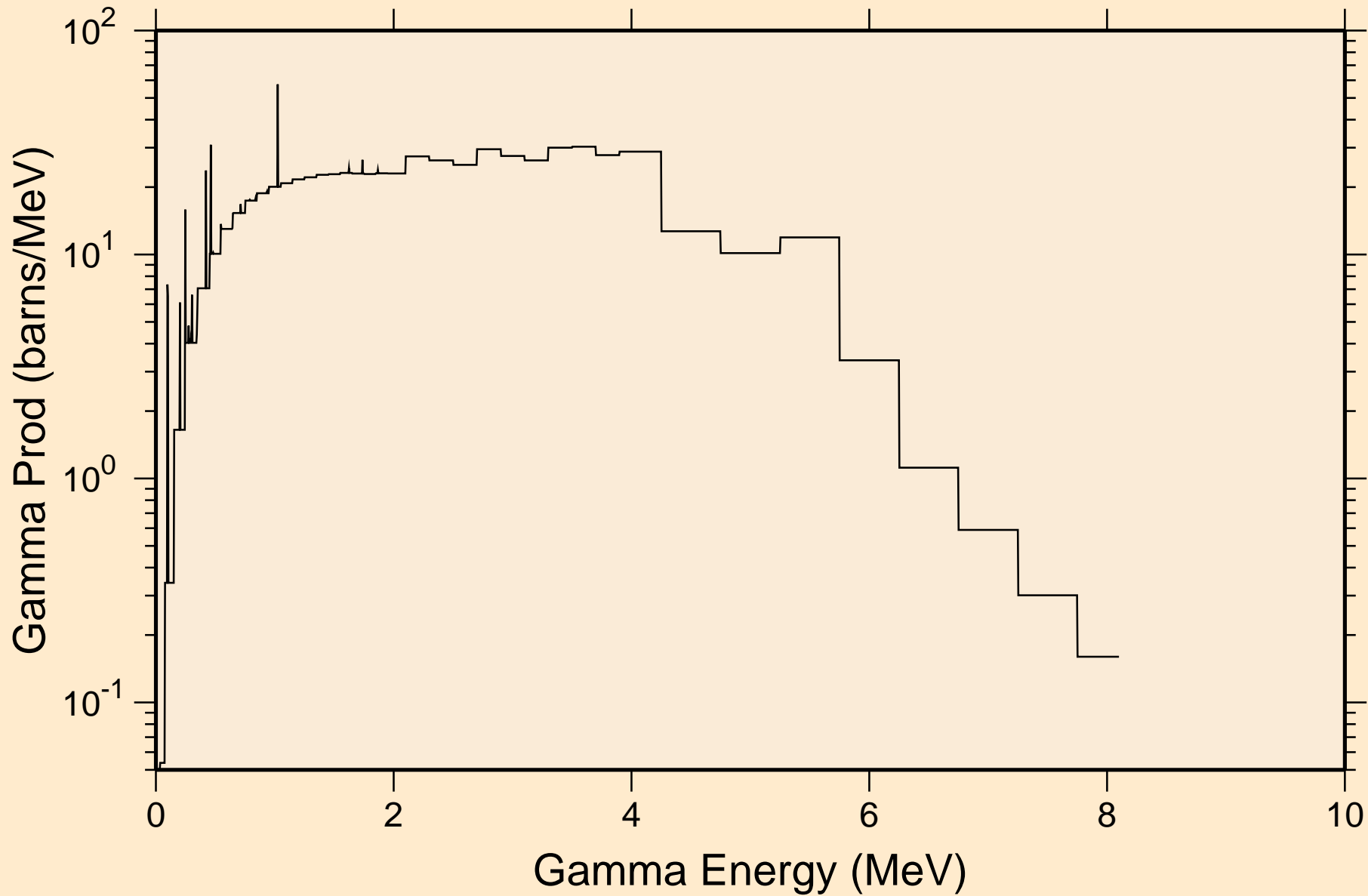

PB199 NEUTRON ACER TENDL-2024 LIBRARY; T=293.6K  
14 MeV photon spectrum

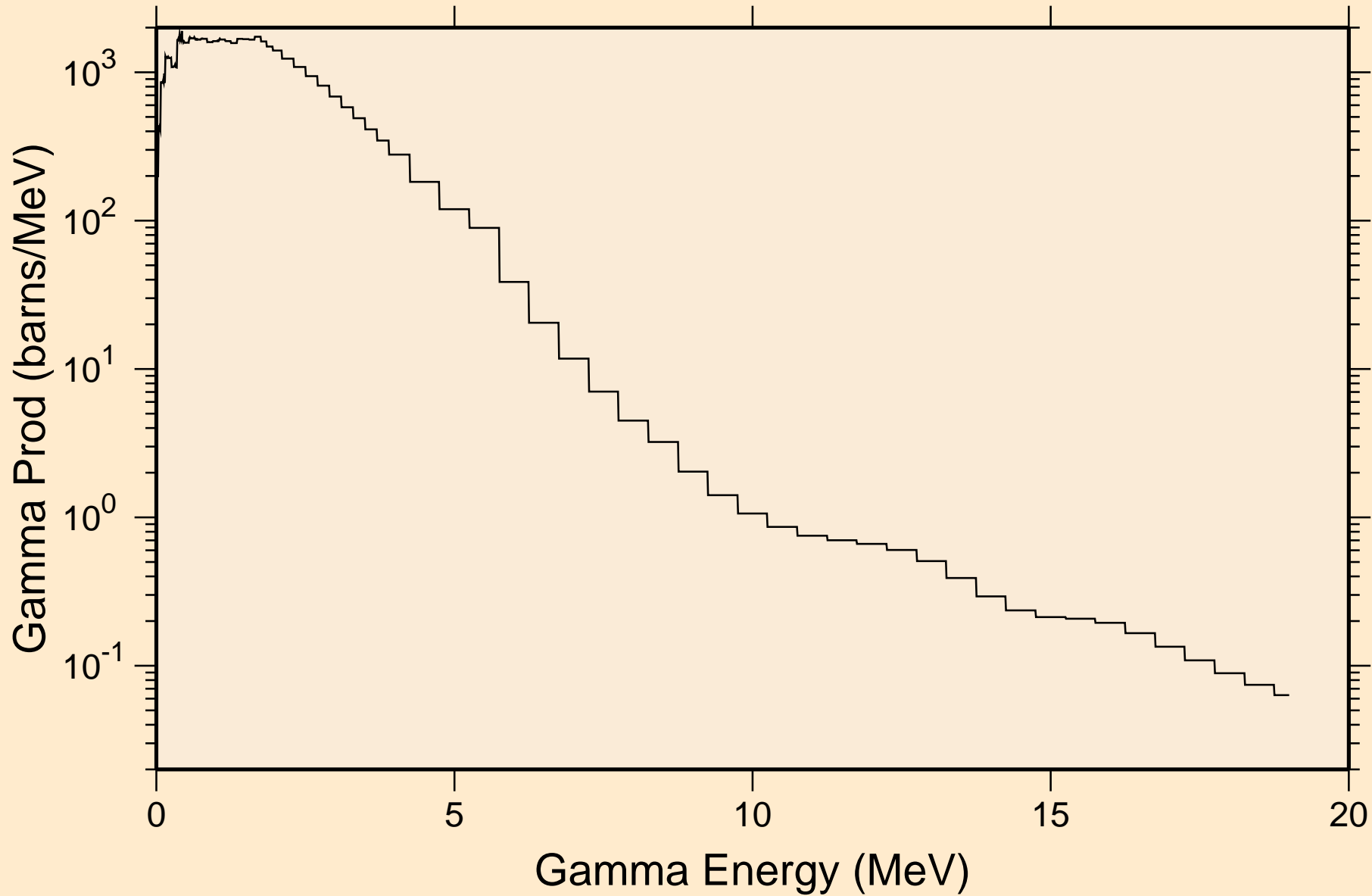

PB199 NEUTRON ACER TENDL-2024 LIBRARY; T=293.6K  
Particle heating contributions

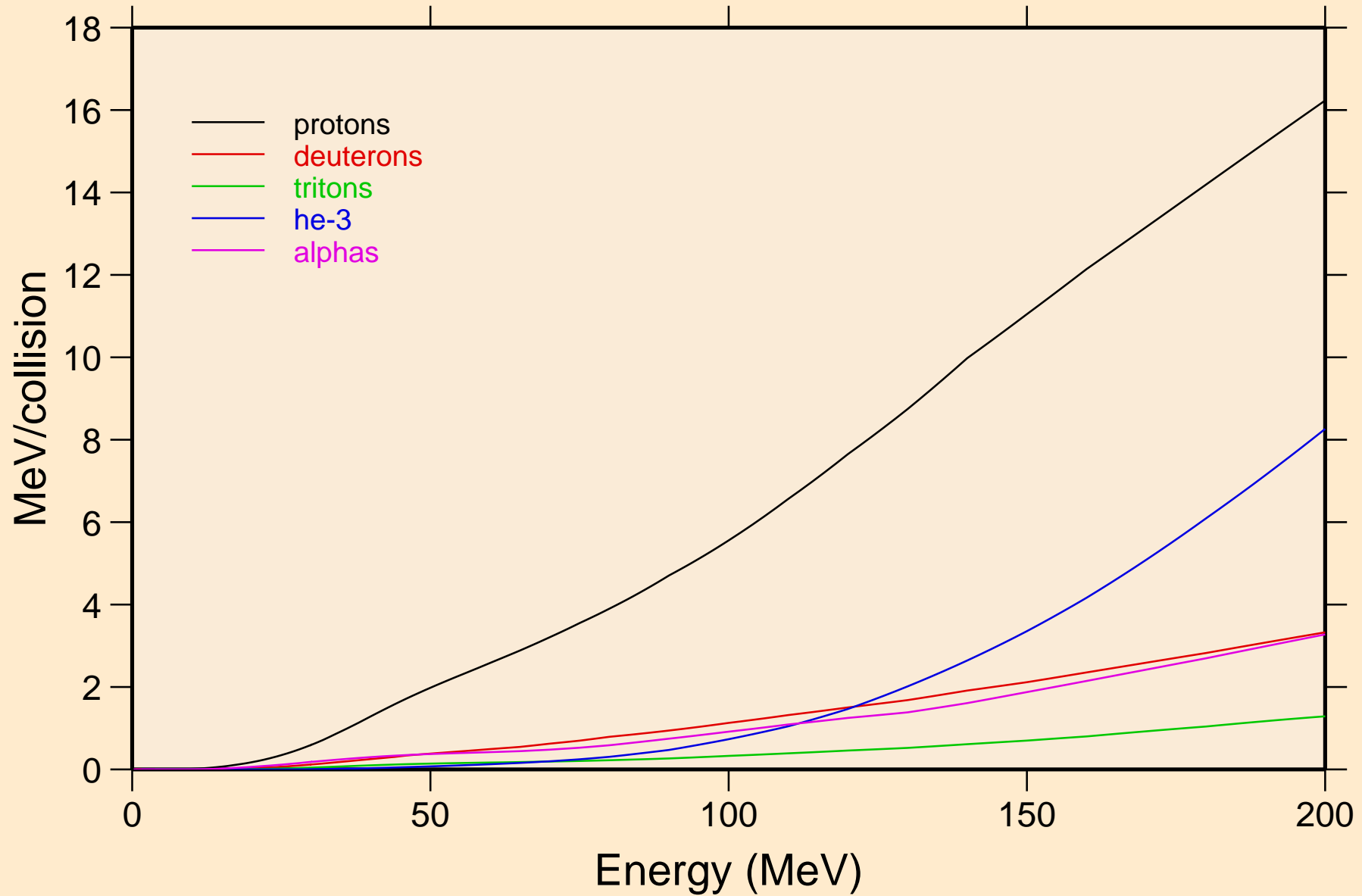

PB199 NEUTRON ACER TENDL-2024 LIBRARY; T=293.6K  
Recoil Heating

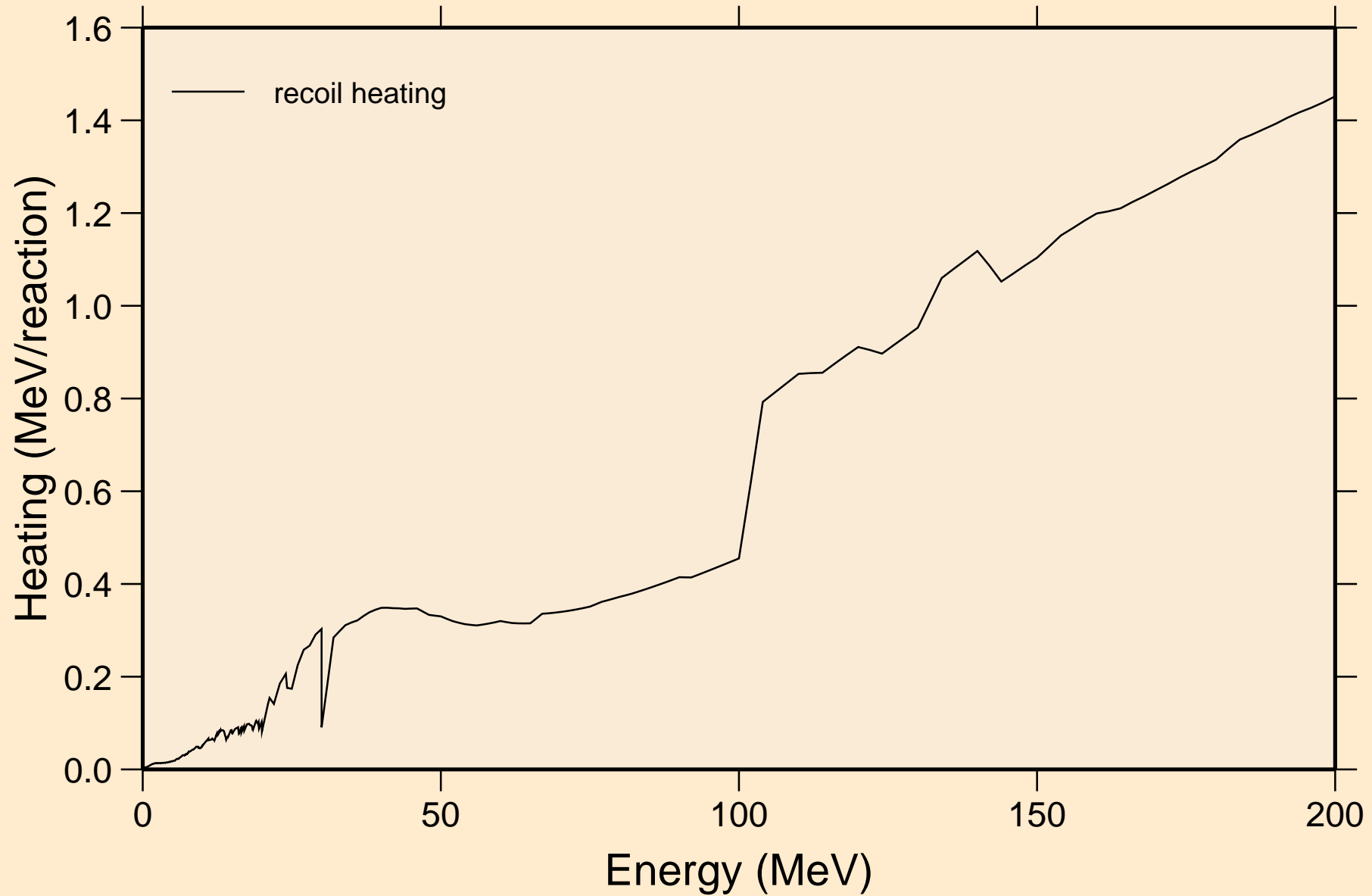

PB199 NEUTRON ACER TENDL-2024 LIBRARY; T=293.6K  
Particle production cross sections

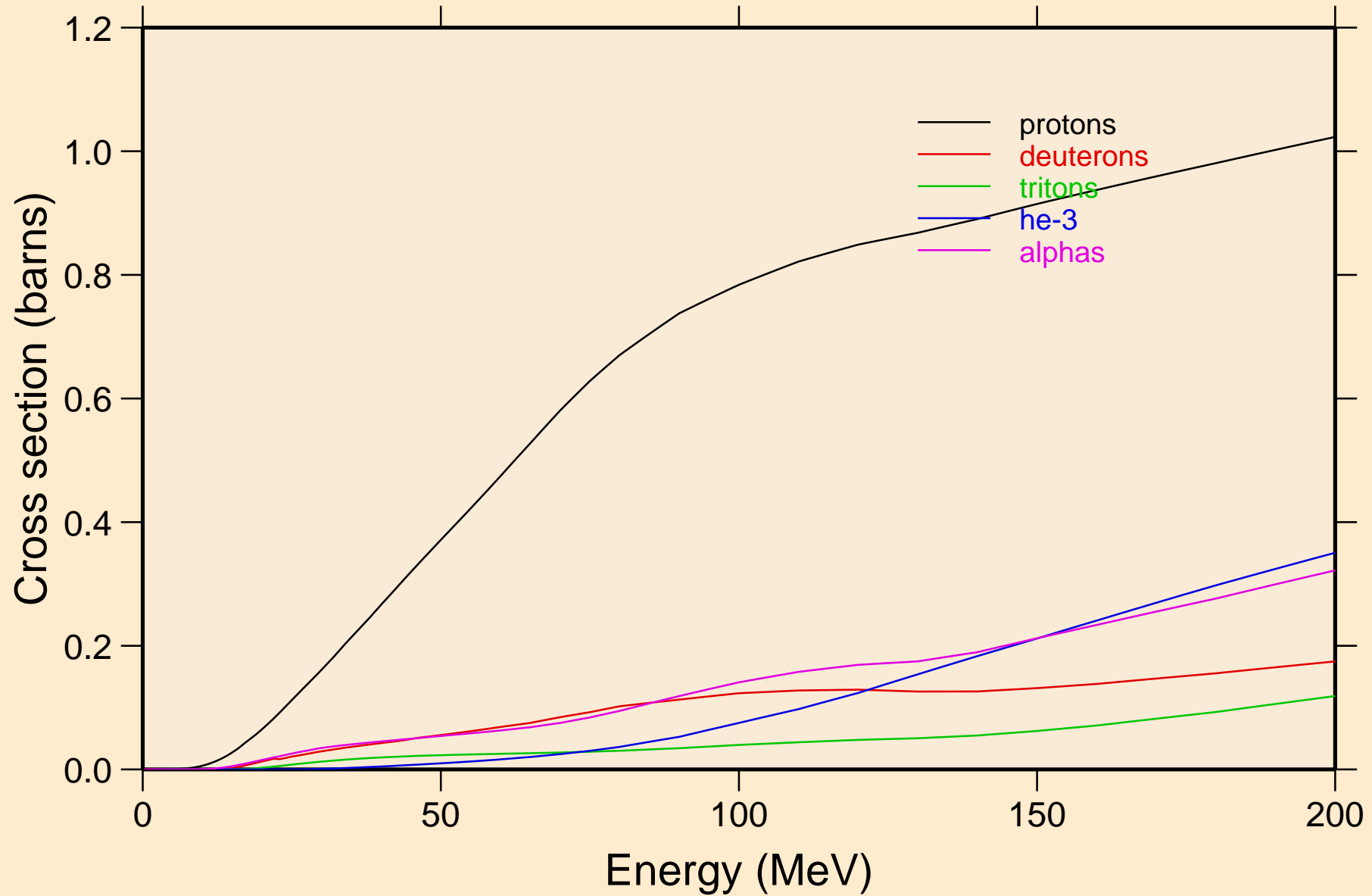

PB199 NEUTRON ACER TENDL-2024 LIBRARY; T=293.6K  
protons from (n,x)

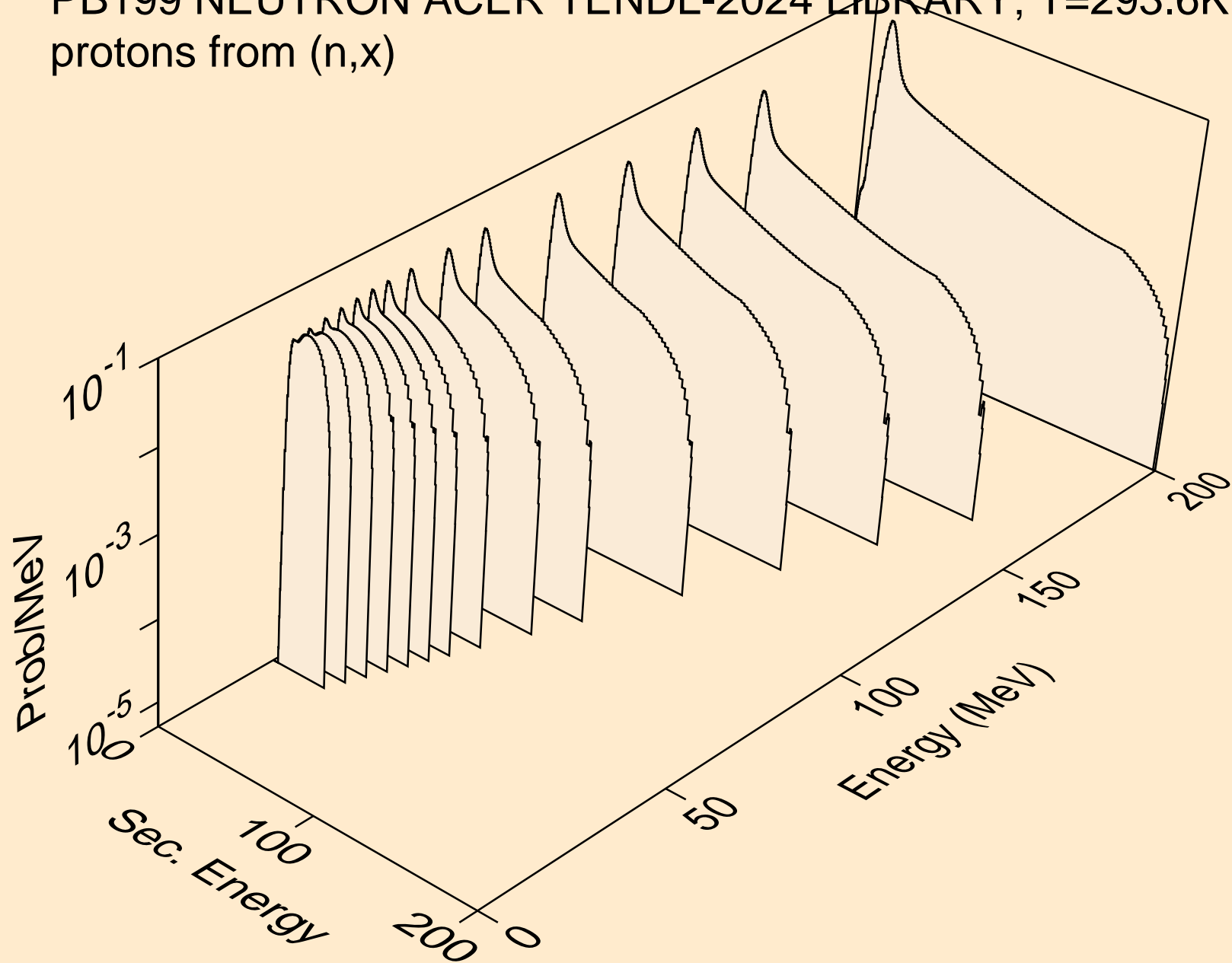

PB199 NEUTRON ACER TENDL-2024 LIBRARY; T=293.6K  
protons from (n,n\*)p

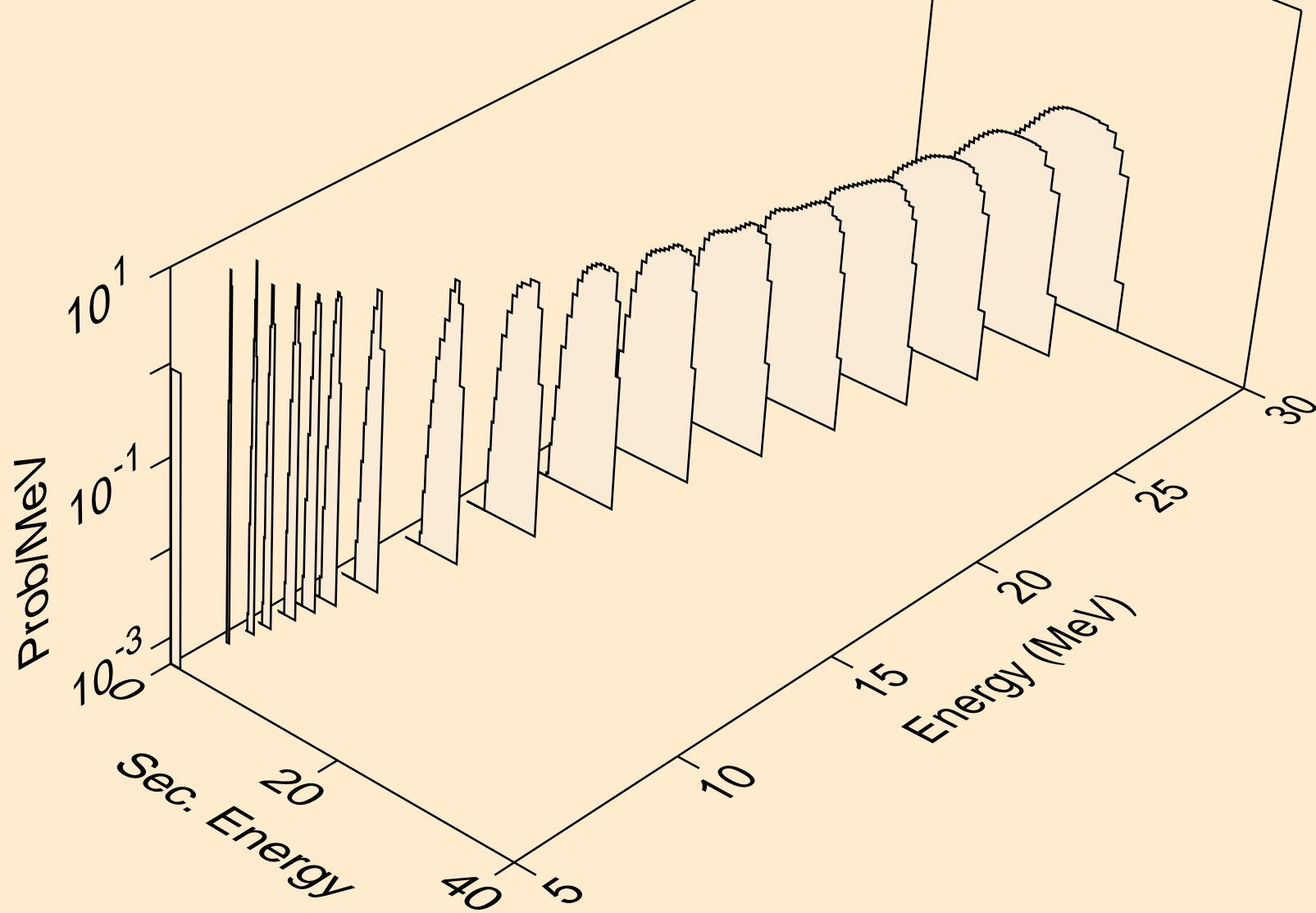

PB199 NEUTRON ACER TENDL-2024 LIBRARY; T=293.6K  
protons from (n,2np)

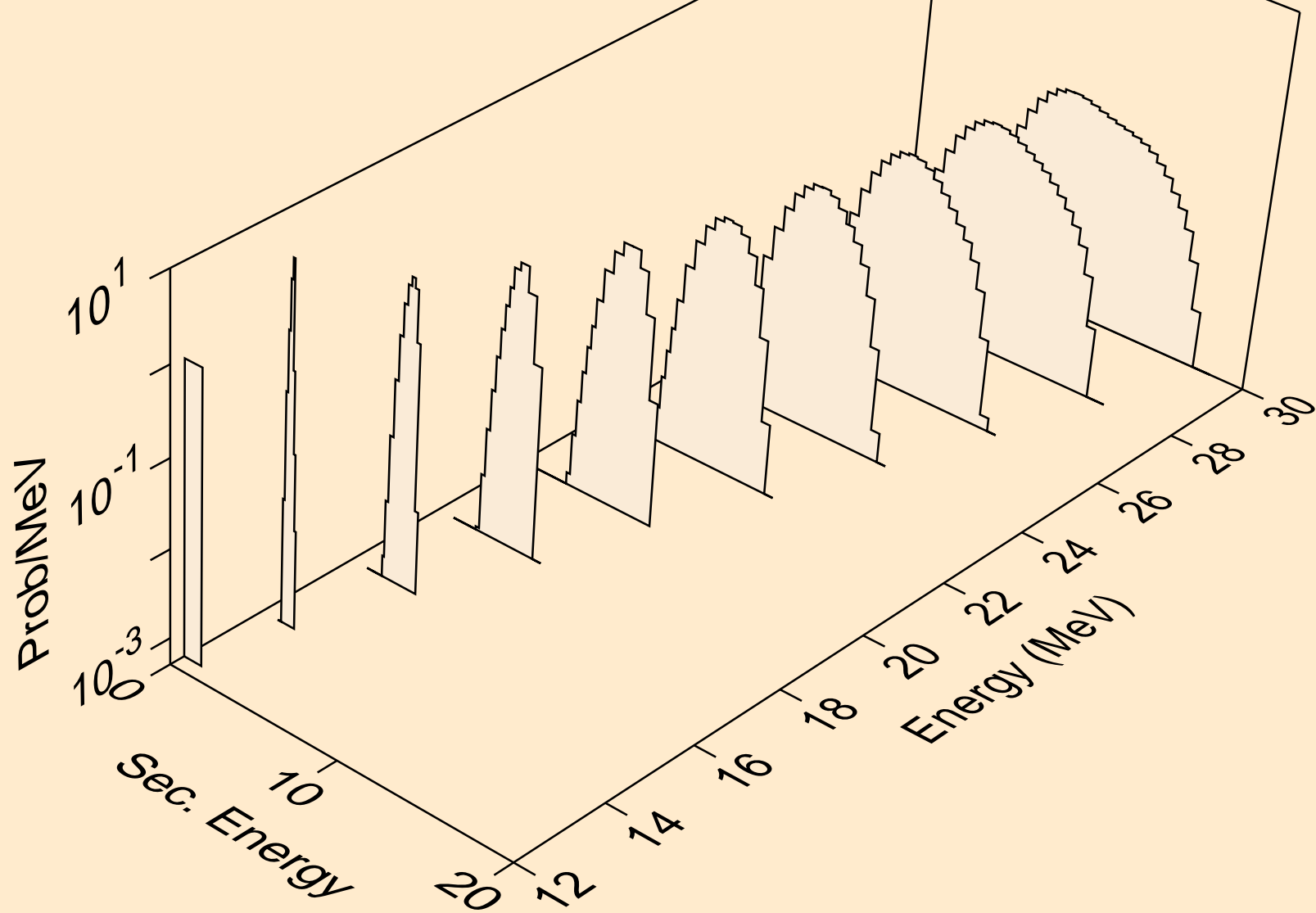

PB199 NEUTRON ACER TENDL-2024 LIBRARY; T=293.6K  
protons from (n,3np)

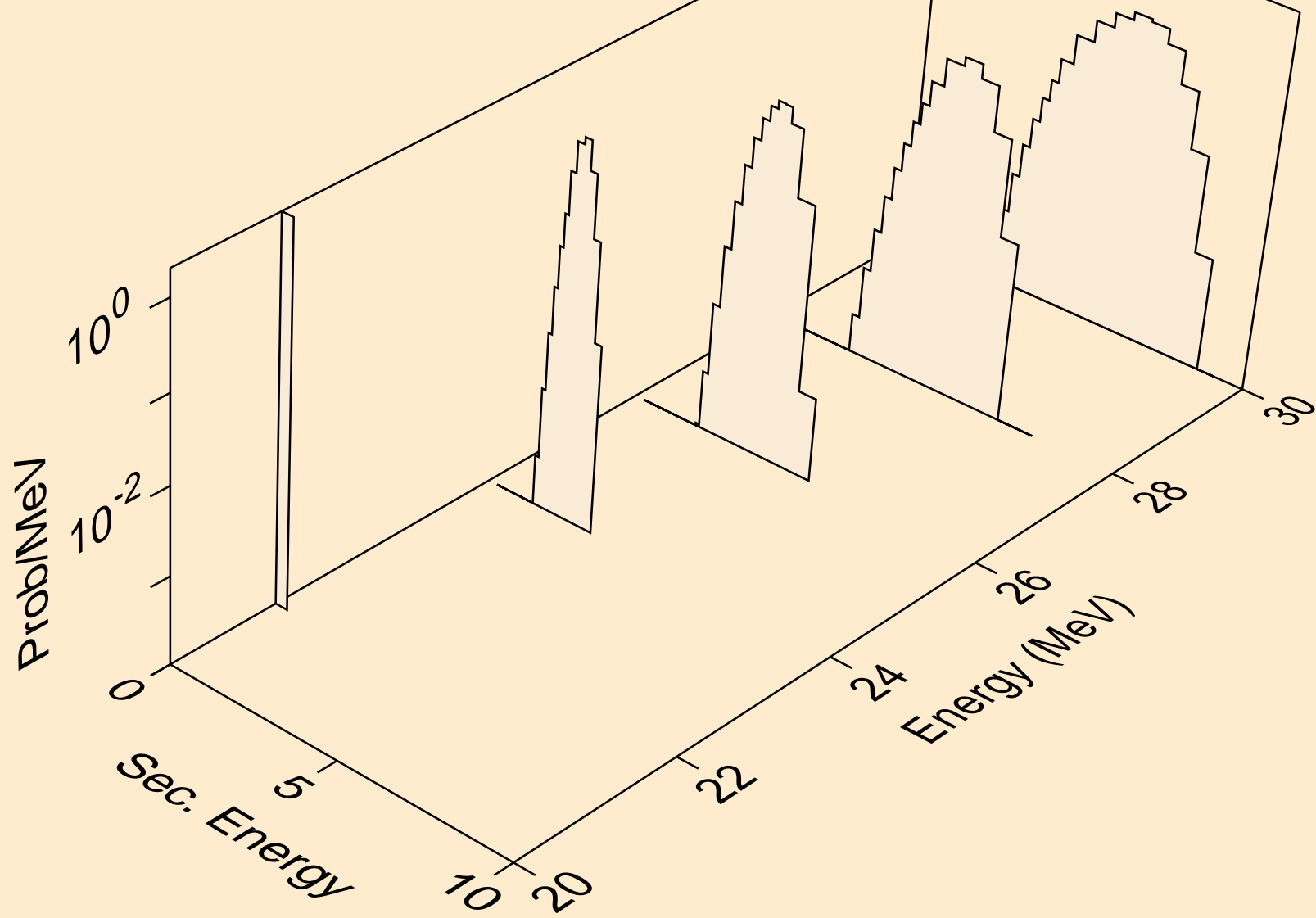

PB199 NEUTRON ACER TENDL-2024 LIBRARY; T=293.6K  
protons from (n,n2p)

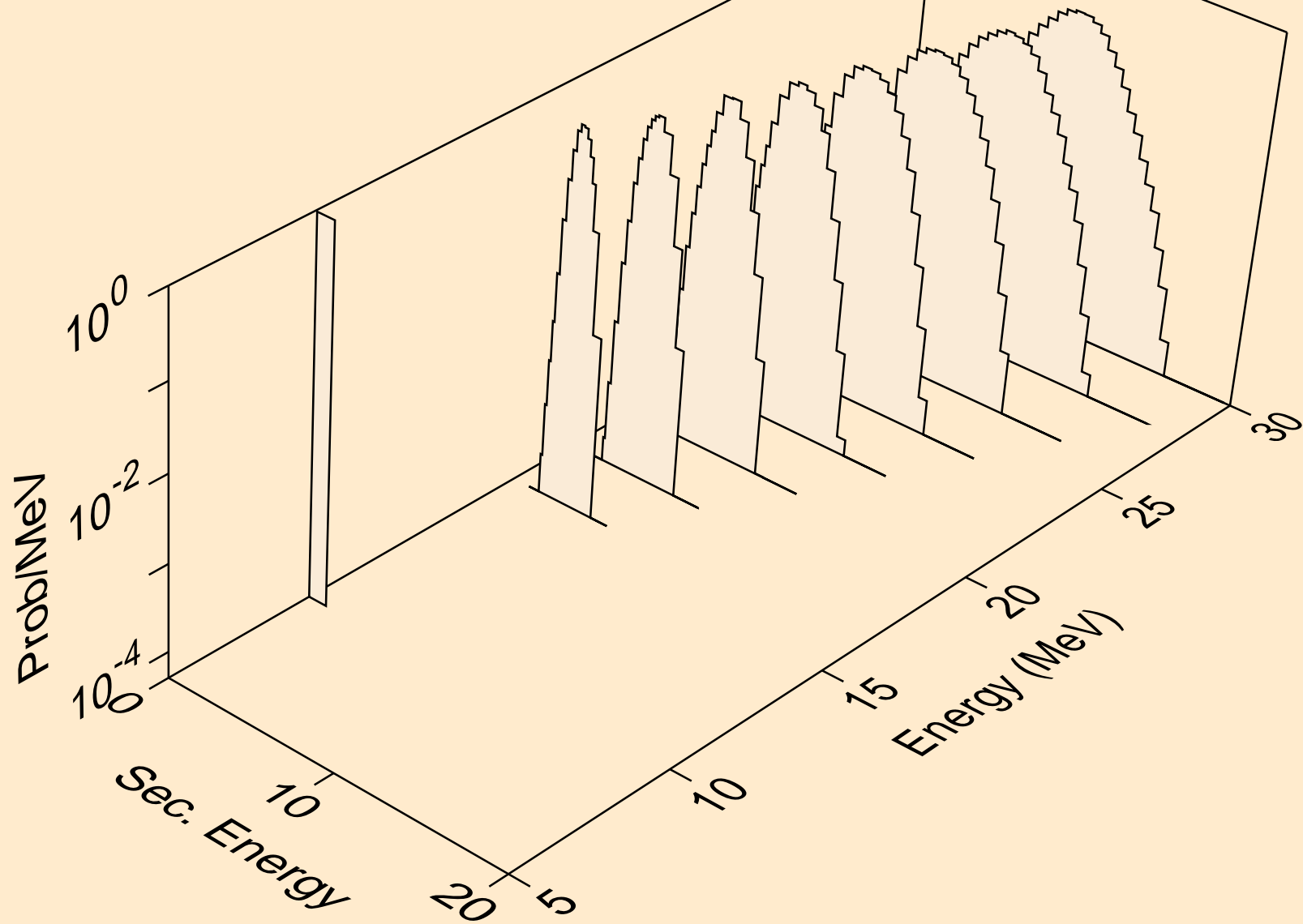

PB199 NEUTRON ACER TENDL-2024 LIBRARY; T=293.6K  
protons from (n,npa)

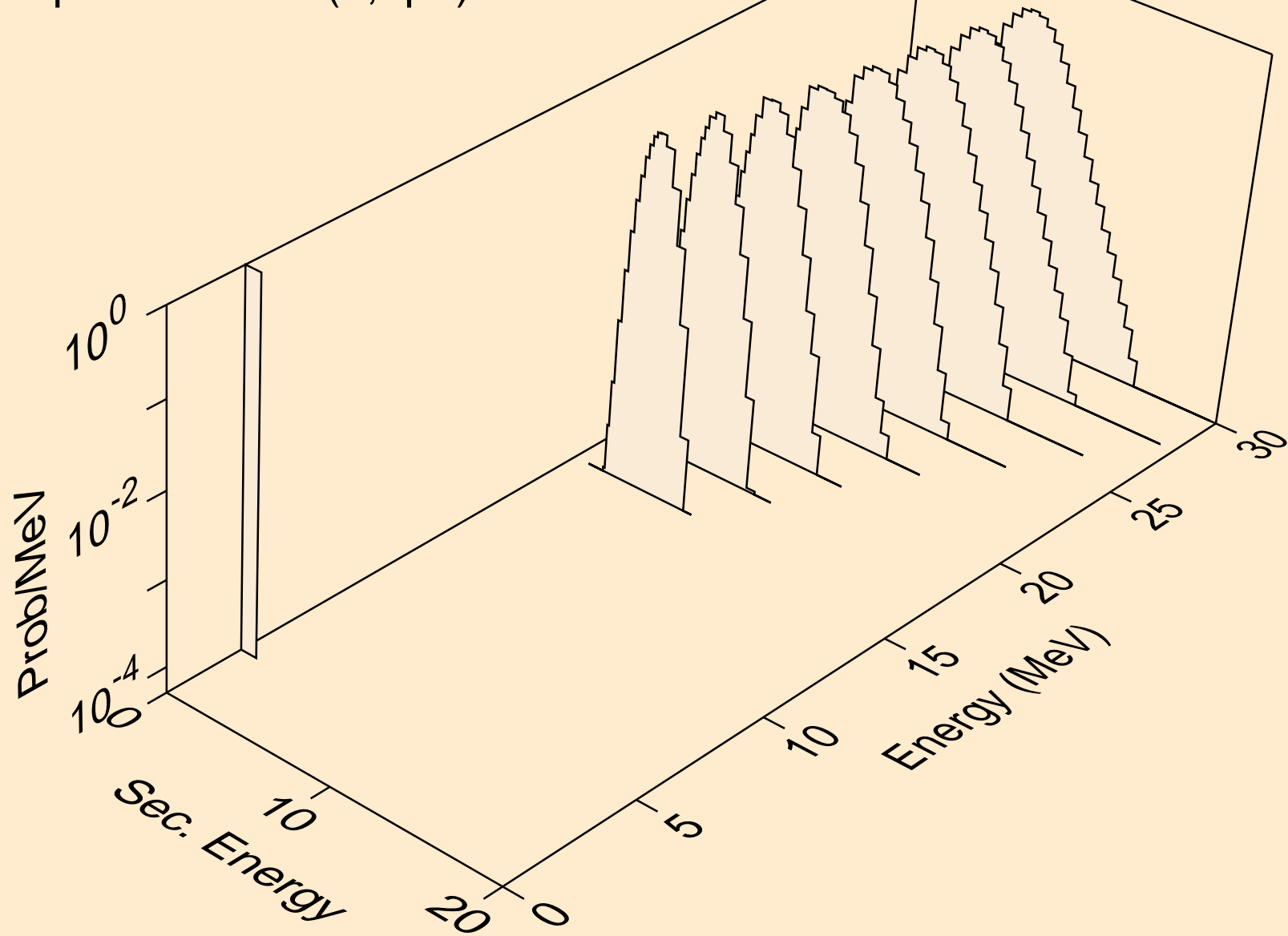

PB199 NEUTRON ACER TENDL-2024 LIBRARY; T=293.6K  
protons from (n,p)

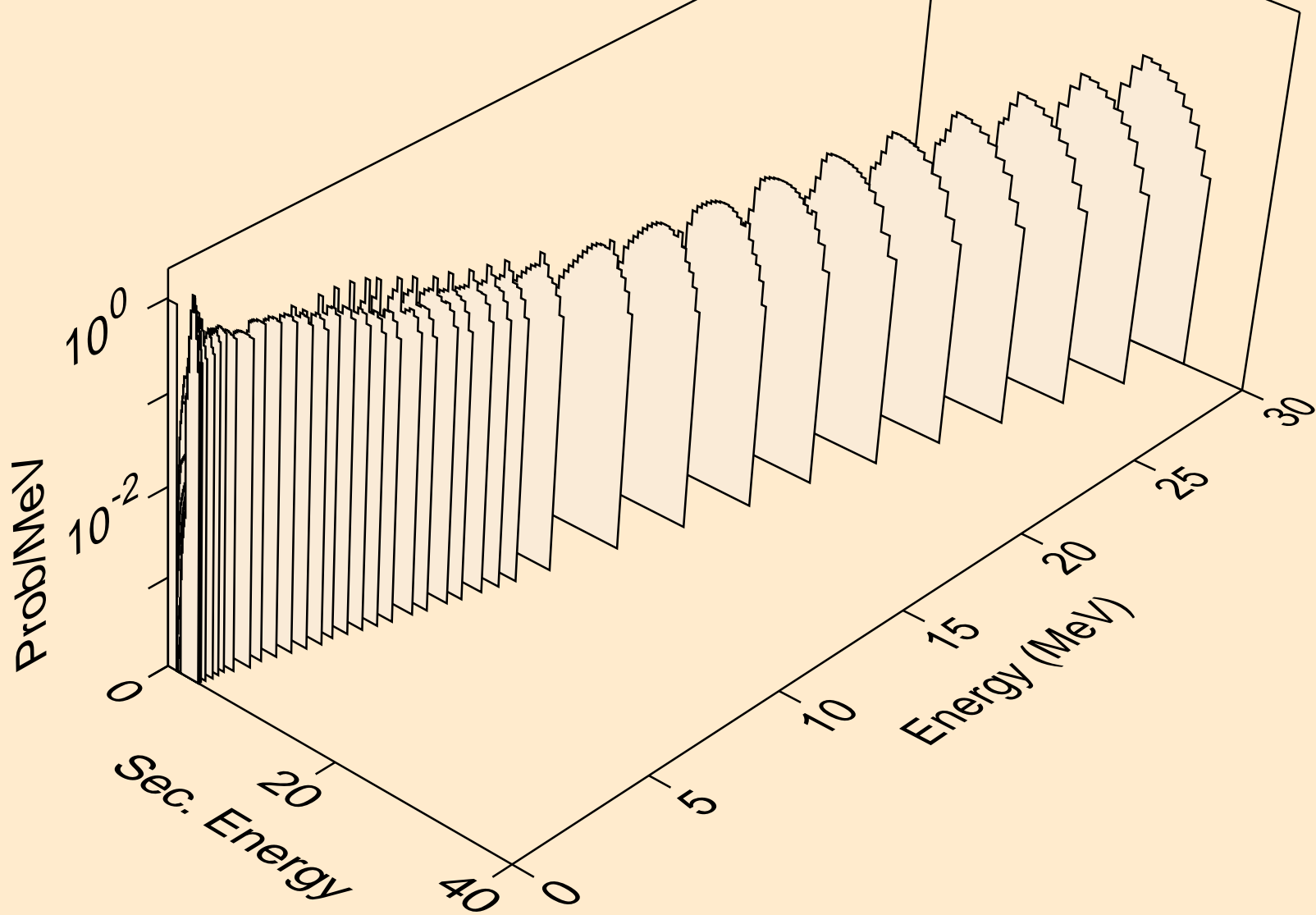

PB199 NEUTRON ACER TENDL-2024 LIBRARY; T=293.6K  
protons from (n,2p)

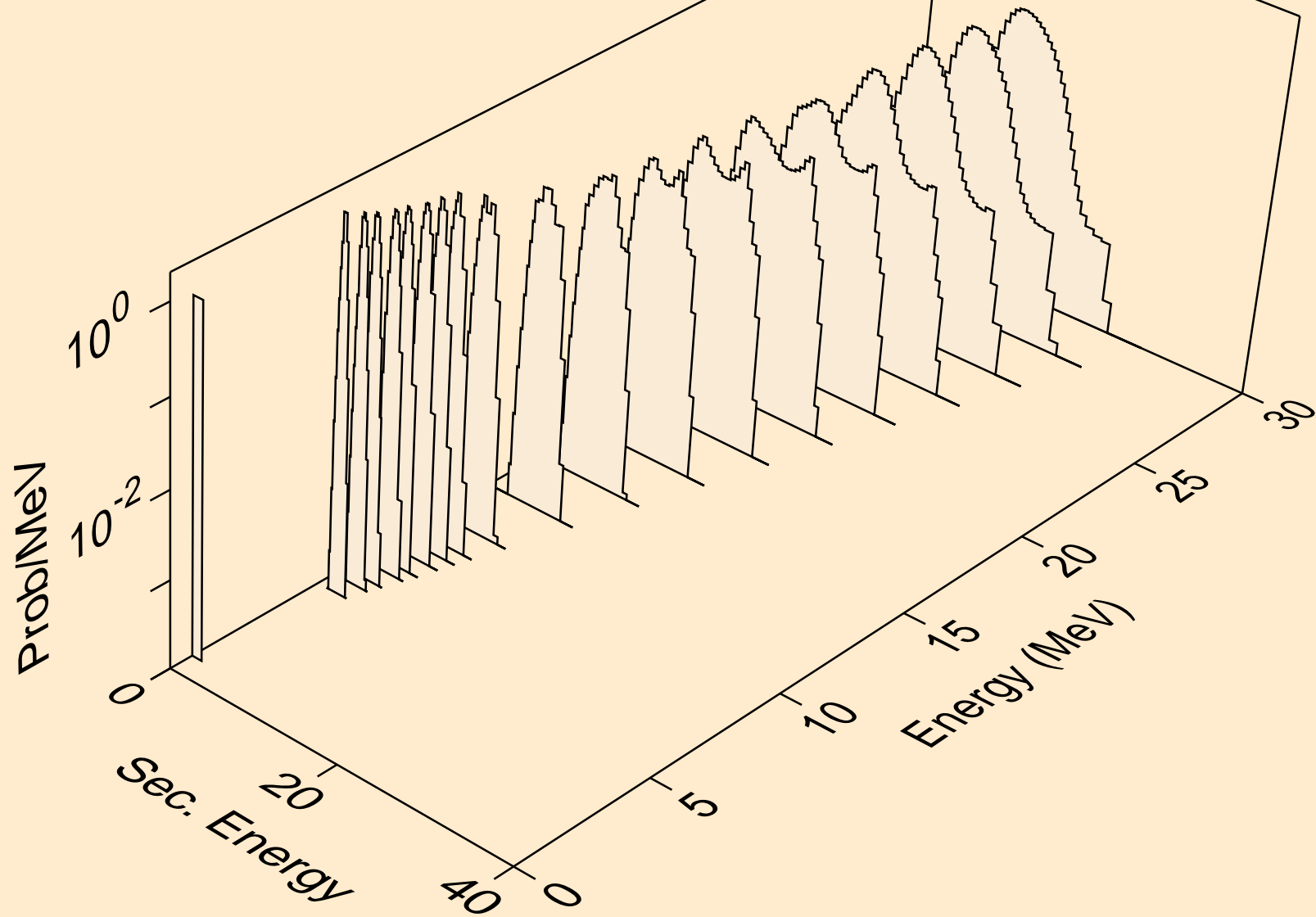

PB199 NEUTRON ACER TENDL-2024 LIBRARY; T=293.6K  
protons from (n,p)

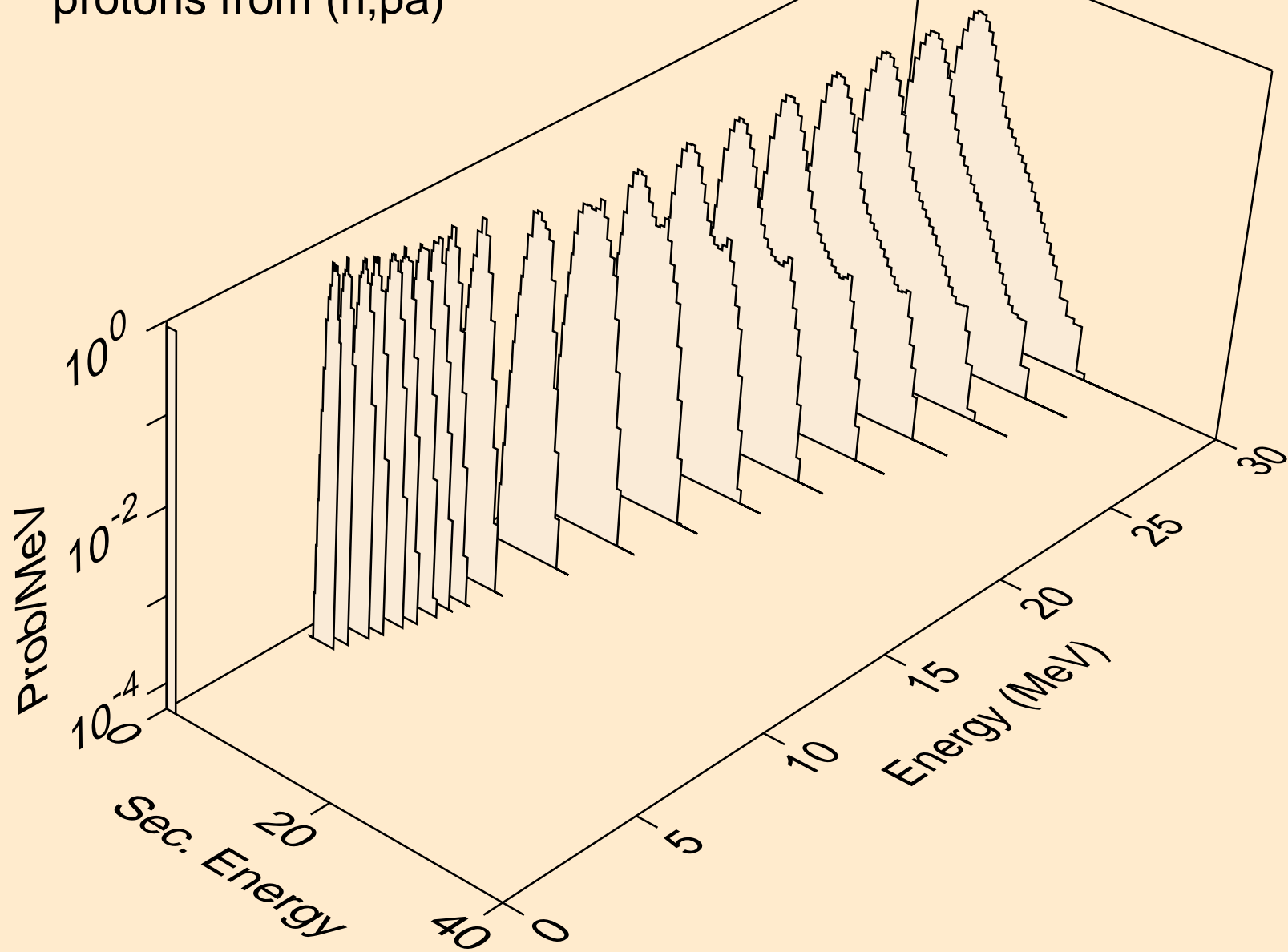

PB199 NEUTRON ACER TENDL-2024 LIBRARY; T=293.6K  
protons from (n,pd)

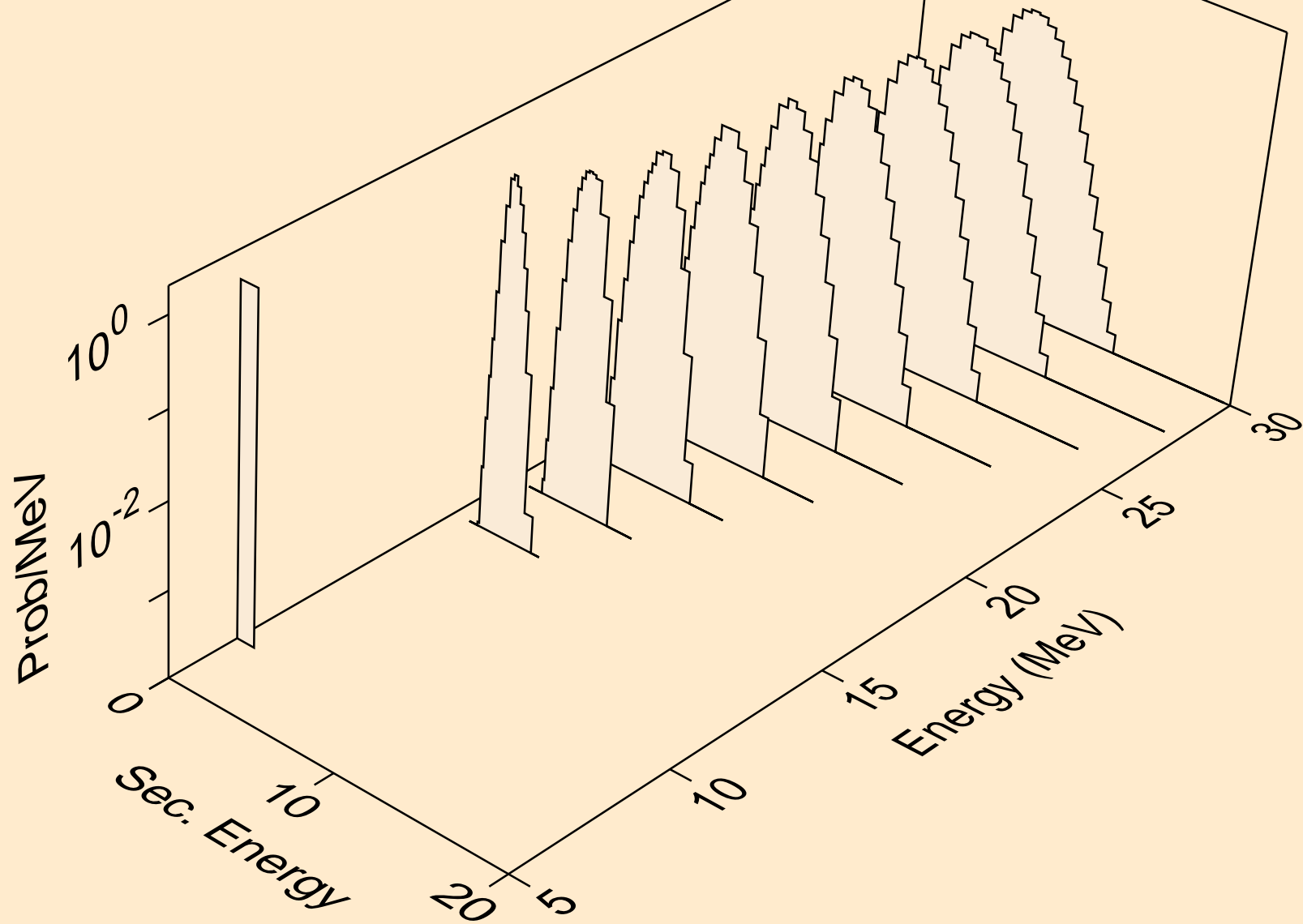

PB199 NEUTRON ACER TENDL-2024 LIBRARY; T=293.6K  
protons from (n,pt)

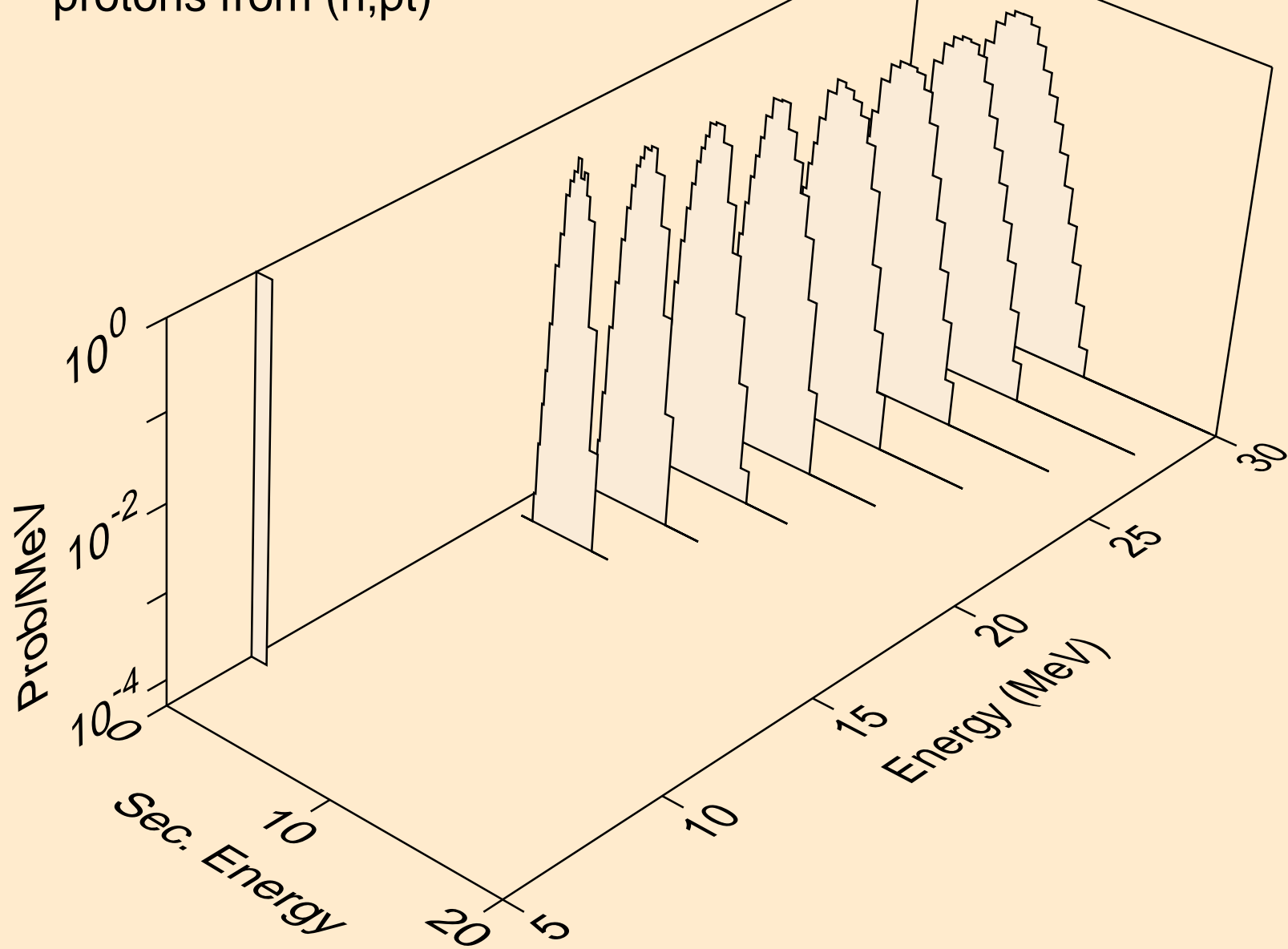

PB199 NEUTRON ACER TENDL-2024 LIBRARY; T=293.6K  
deuterons from (n,x)

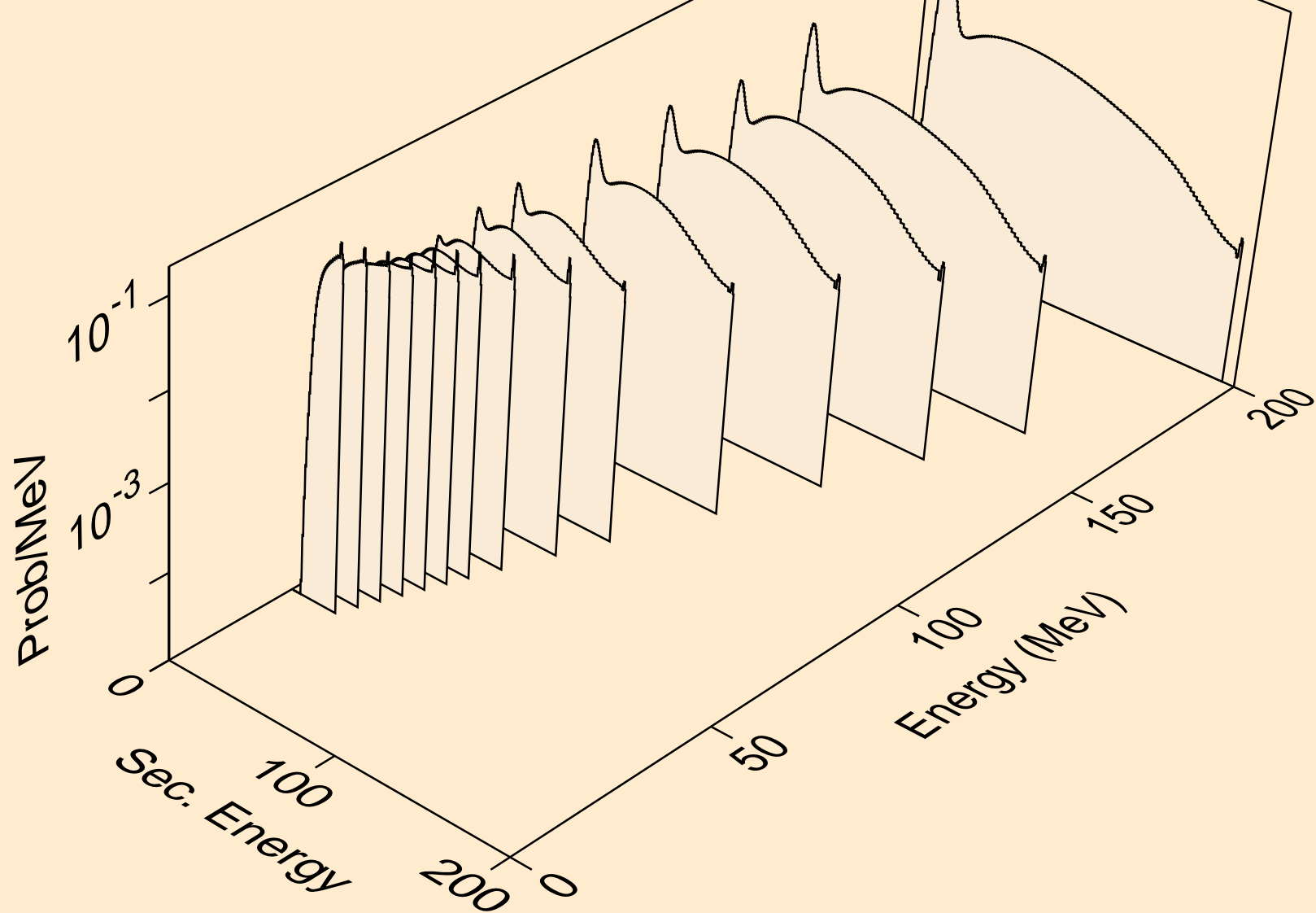

PB199 NEUTRON ACER TENDL-2024 LIBRARY; T=293.6K  
deuterons from (n,2nd)

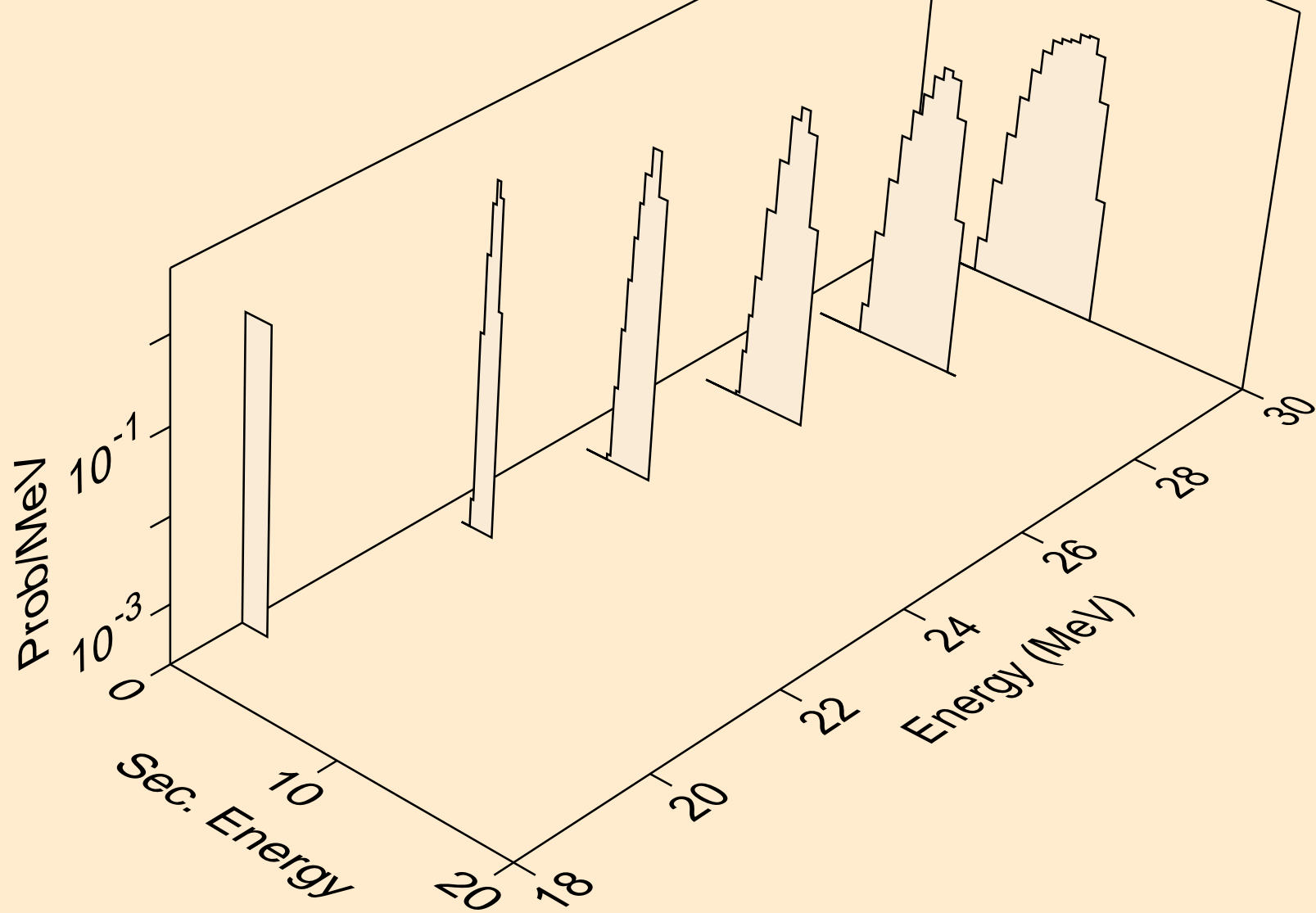

PB199 NEUTRON ACER TENDL-2024 LIBRARY; T=293.6K  
deuterons from (n,n\*)d

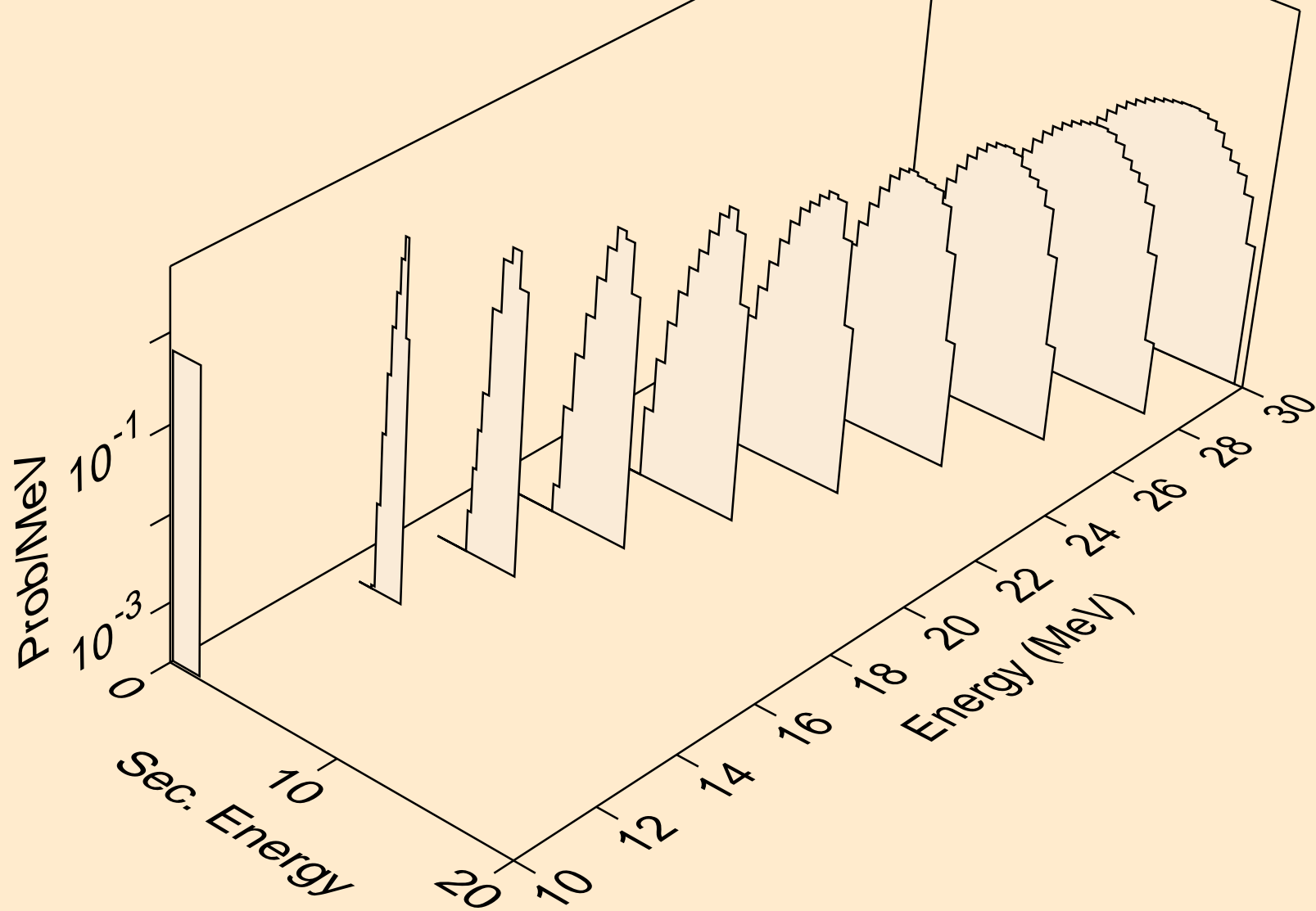

PB199 NEUTRON ACER TENDL-2024 LIBRARY; T=293.6K  
deuterons from (n,d)

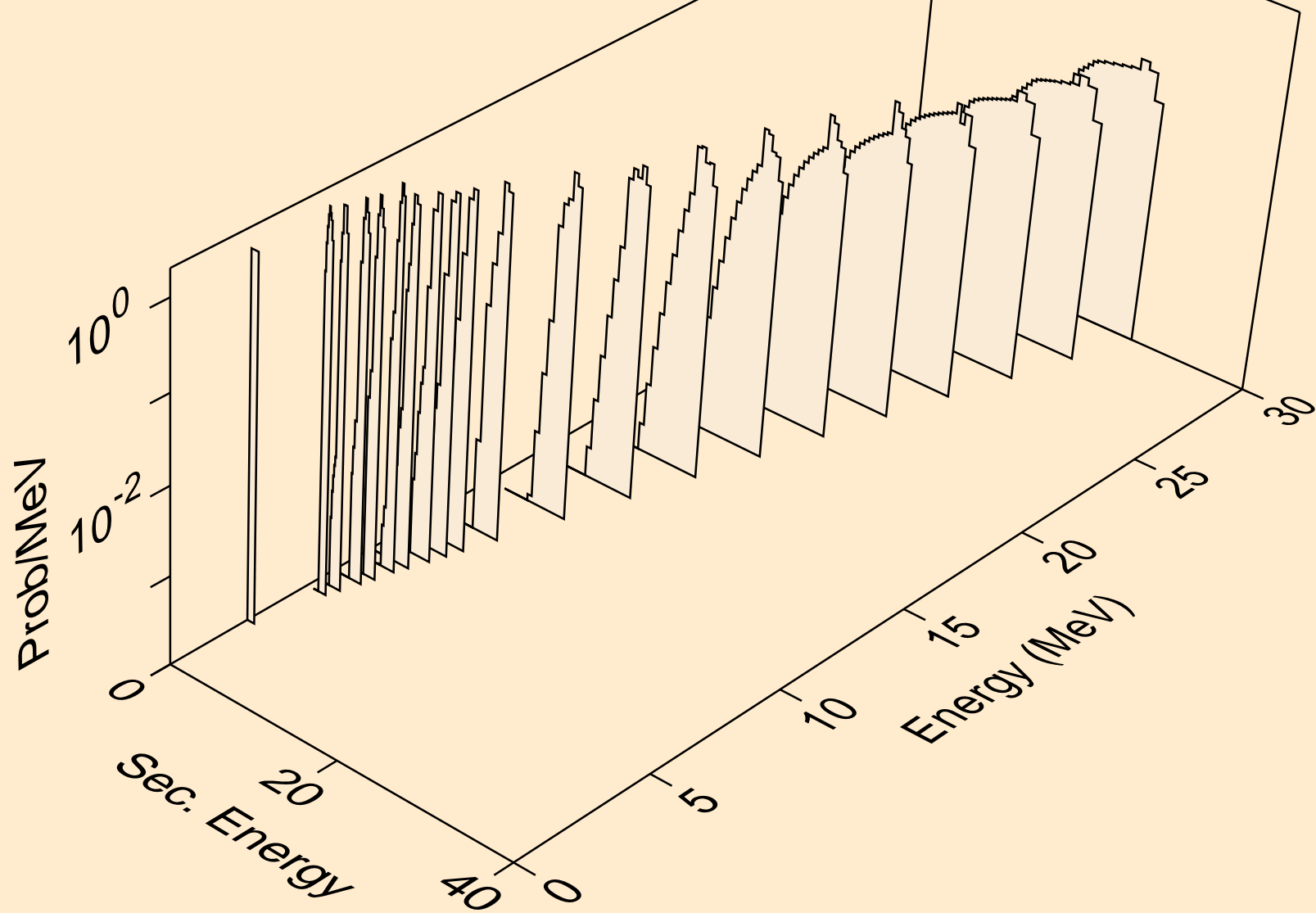

PB199 NEUTRON ACER TENDL-2024 LIBRARY; T=293.6K  
deuterons from (n,pd)

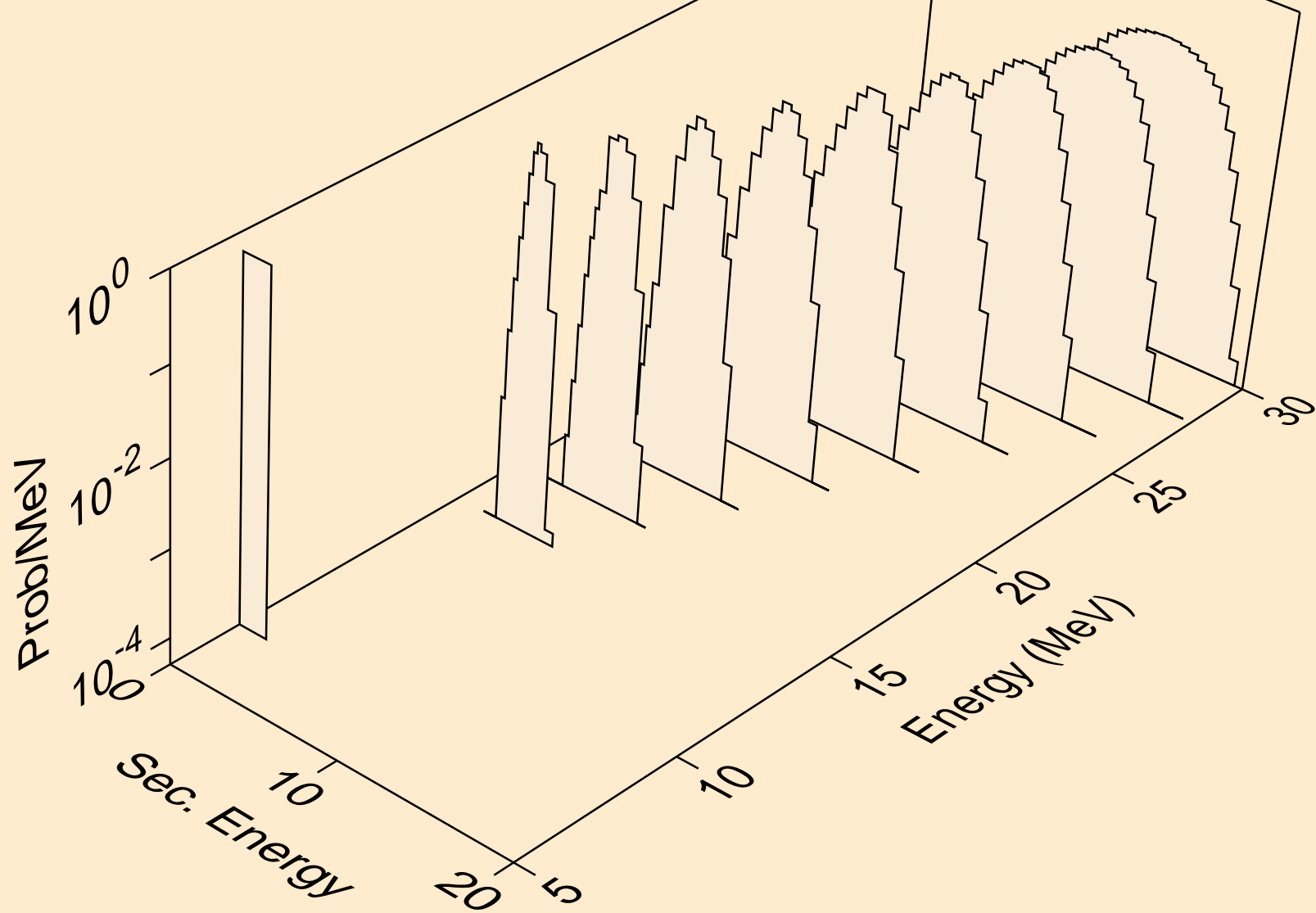

PB199 NEUTRON ACER TENDL-2024 LIBRARY; T=293.6K  
deuterons from (n,da)

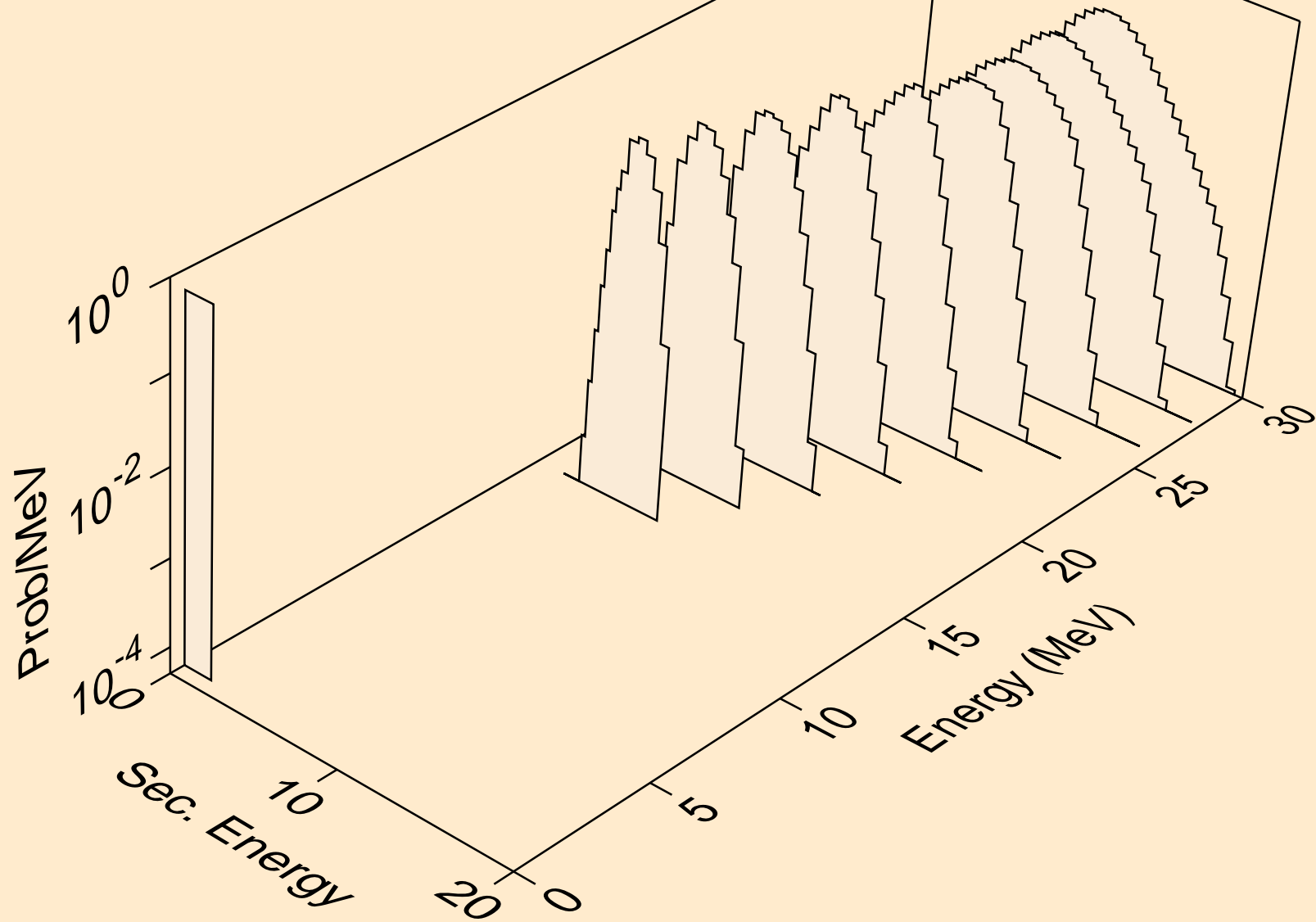

PB199 NEUTRON ACER TENDL-2024 LIBRARY; T=293.6K  
tritons from (n,x)

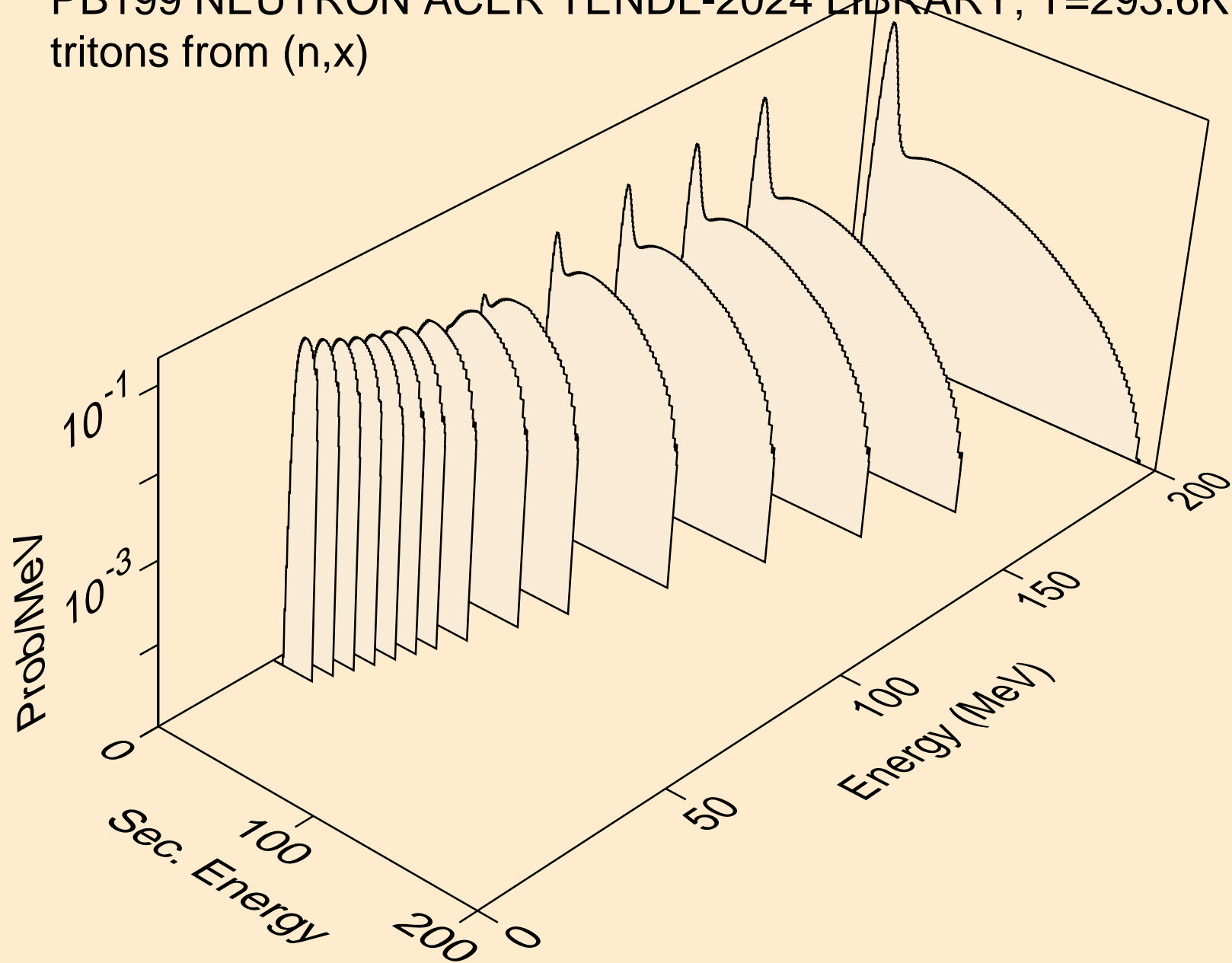

PB199 NEUTRON ACER TENDL-2024 LIBRARY; T=293.6K  
tritons from (n,n\*)t

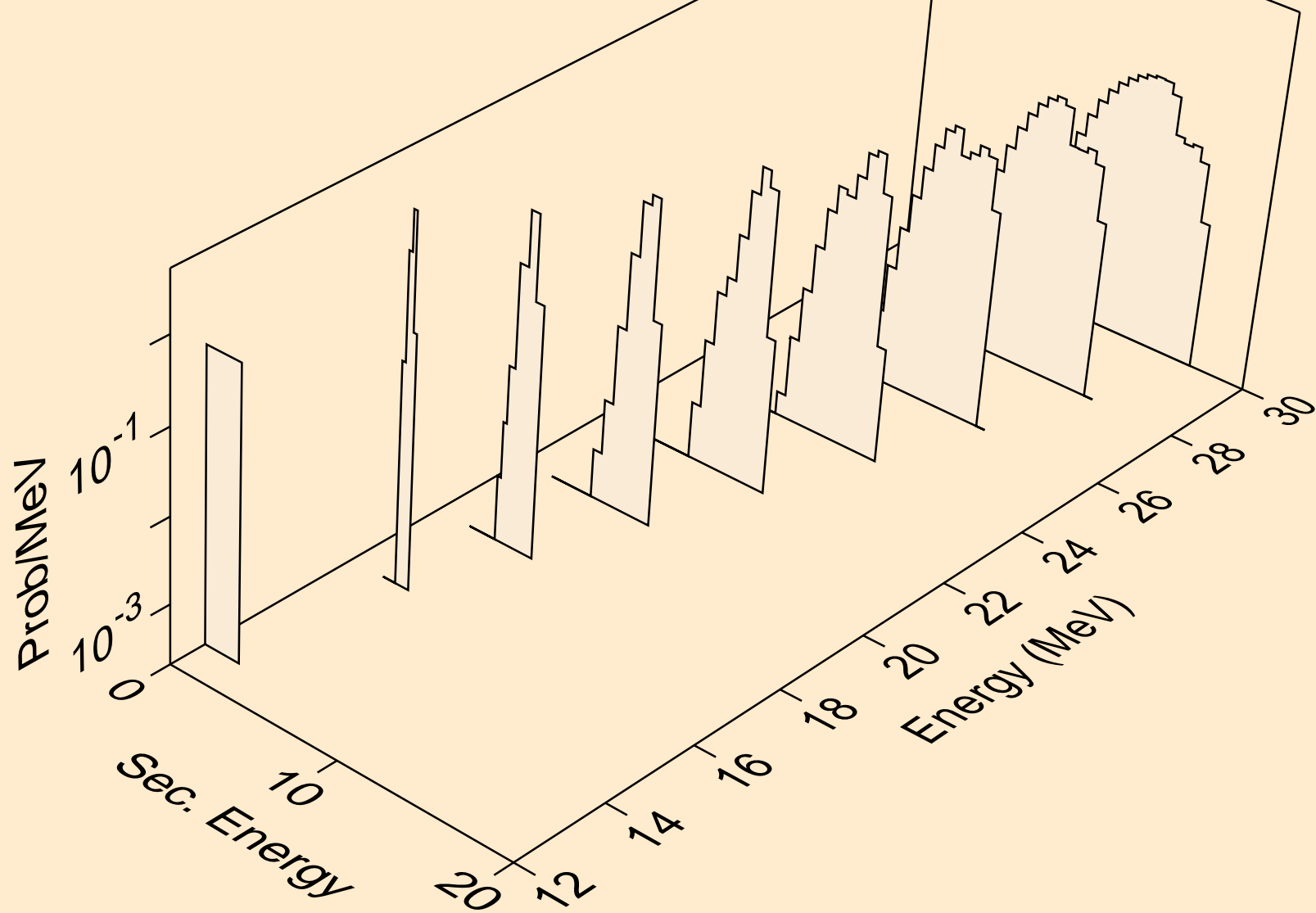

PB199 NEUTRON ACER TENDL-2024 LIBRARY; T=293.6K  
tritons from (n,t)

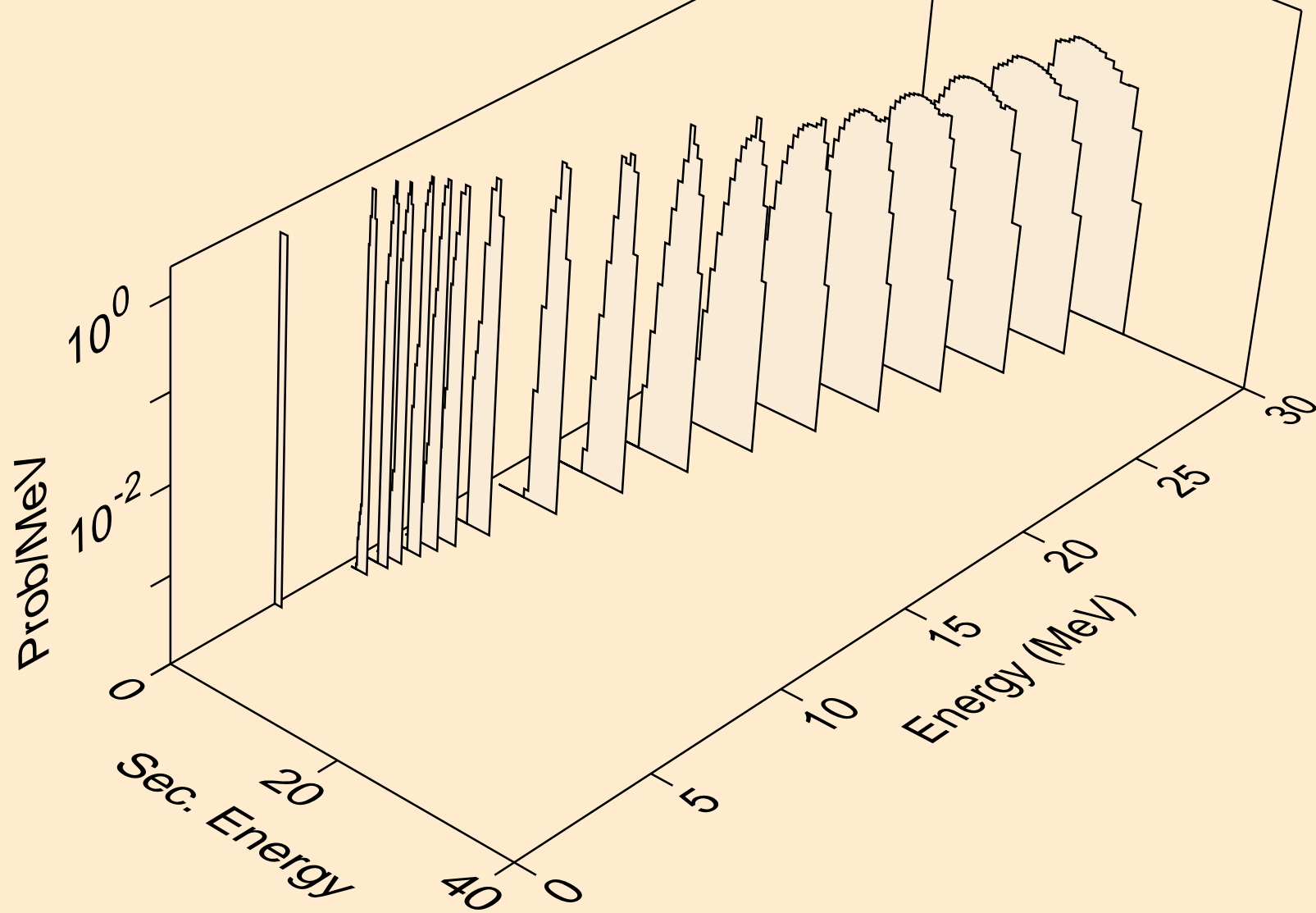

PB199 NEUTRON ACER TENDL-2024 LIBRARY; T=293.6K  
tritons from (n,pt)

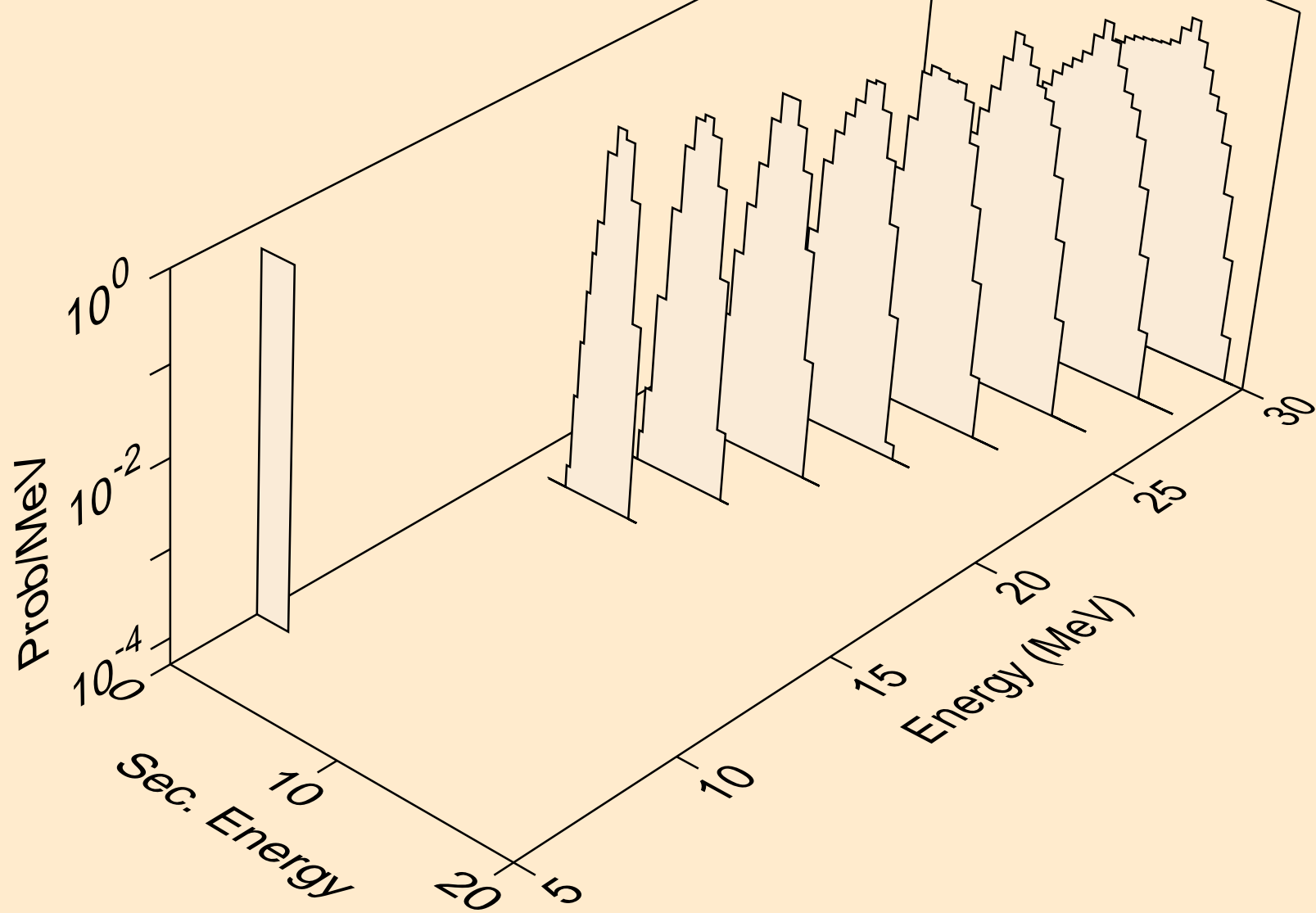

PB199 NEUTRON ACER TENDL-2024 LIBRARY; T=293.6K  
he3s from (n,x)

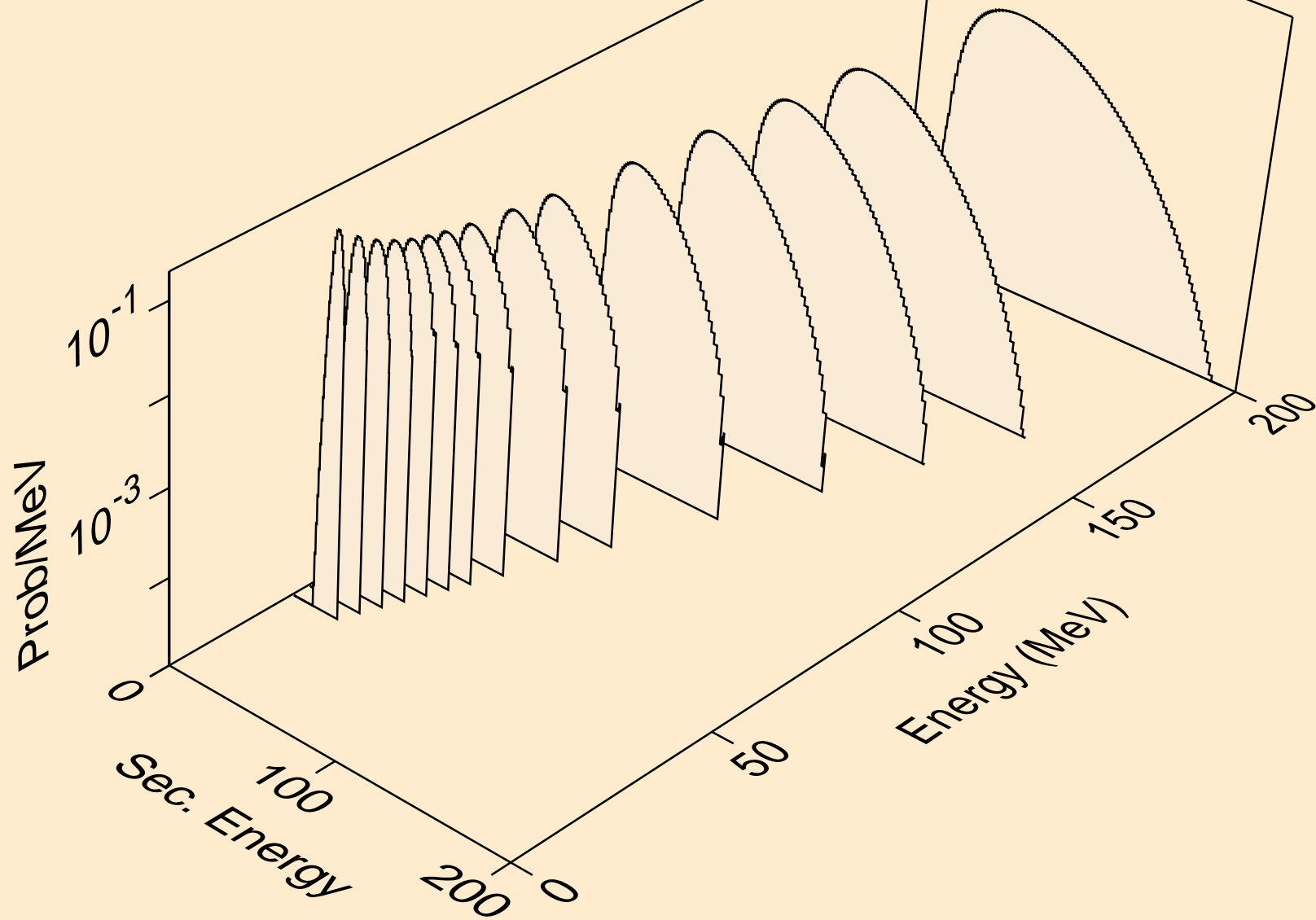

PB199 NEUTRON ACER TENDL-2024 LIBRARY; T=293.6K  
he3s from (n,n\*)he3

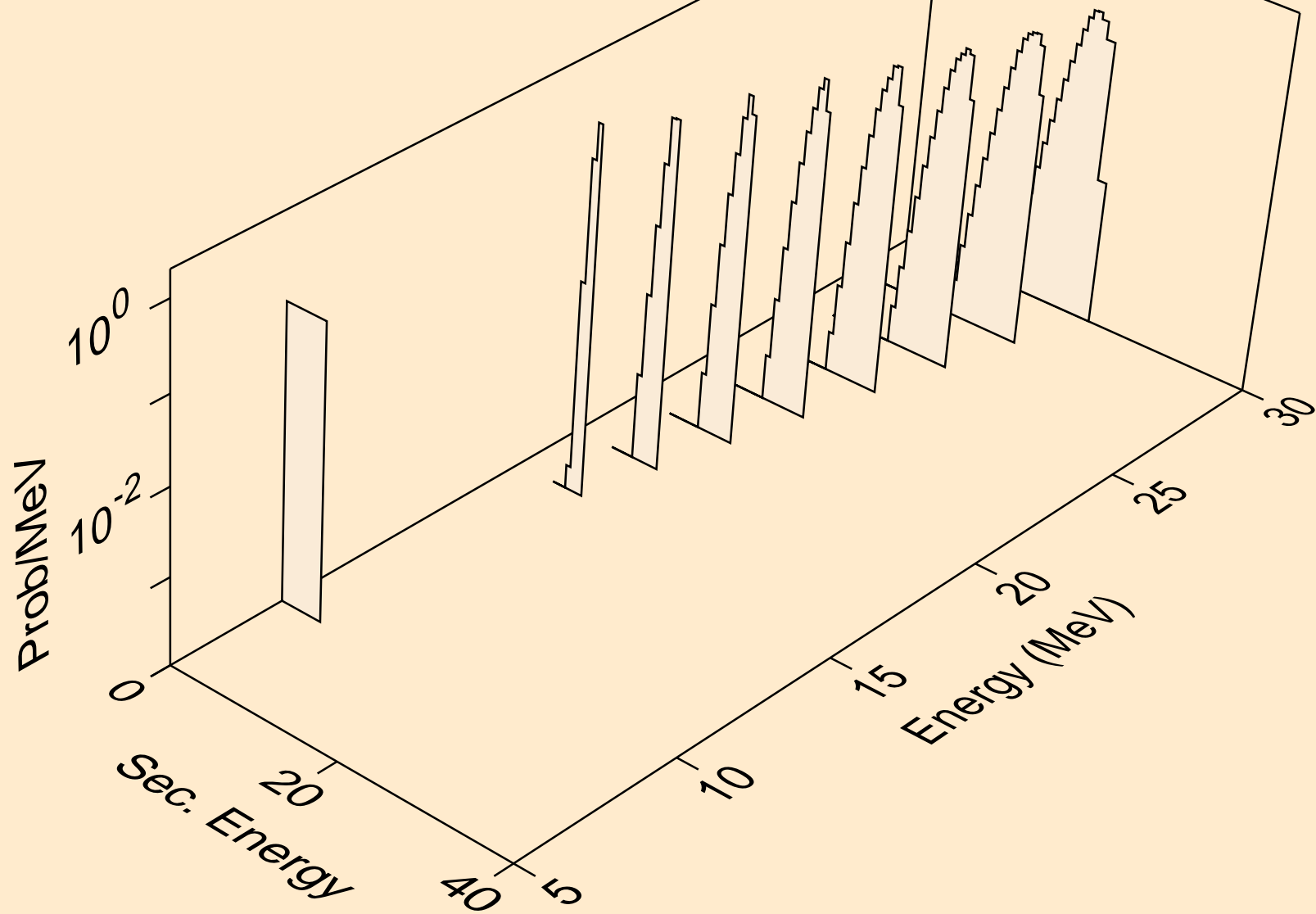

PB199 NEUTRON ACER TENDL-2024 LIBRARY; T=293.6K  
he3s from (n,he3)

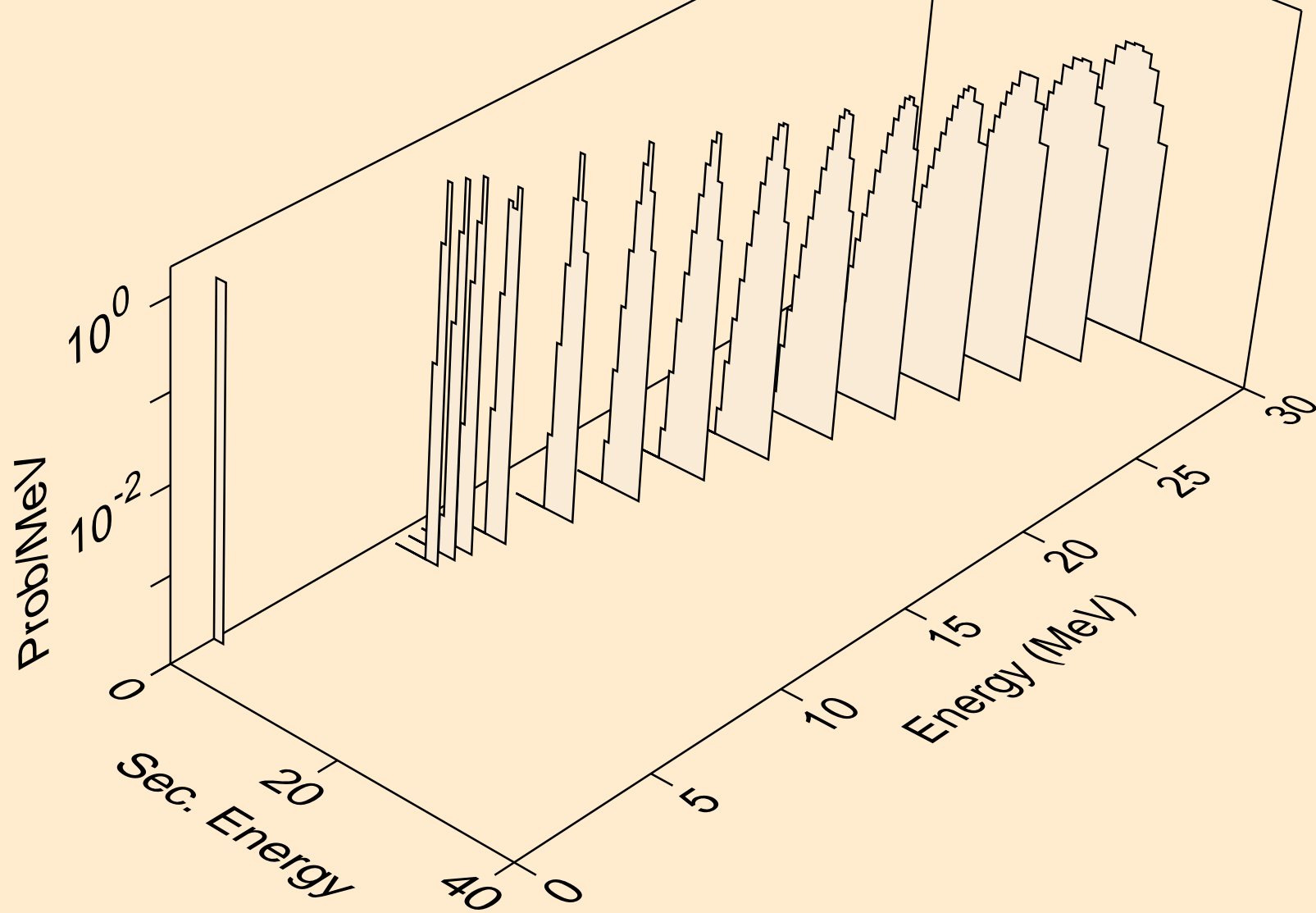

PB199 NEUTRON ACER TENDL-2024 LIBRARY; T=293.6K  
alphas from (n,x)

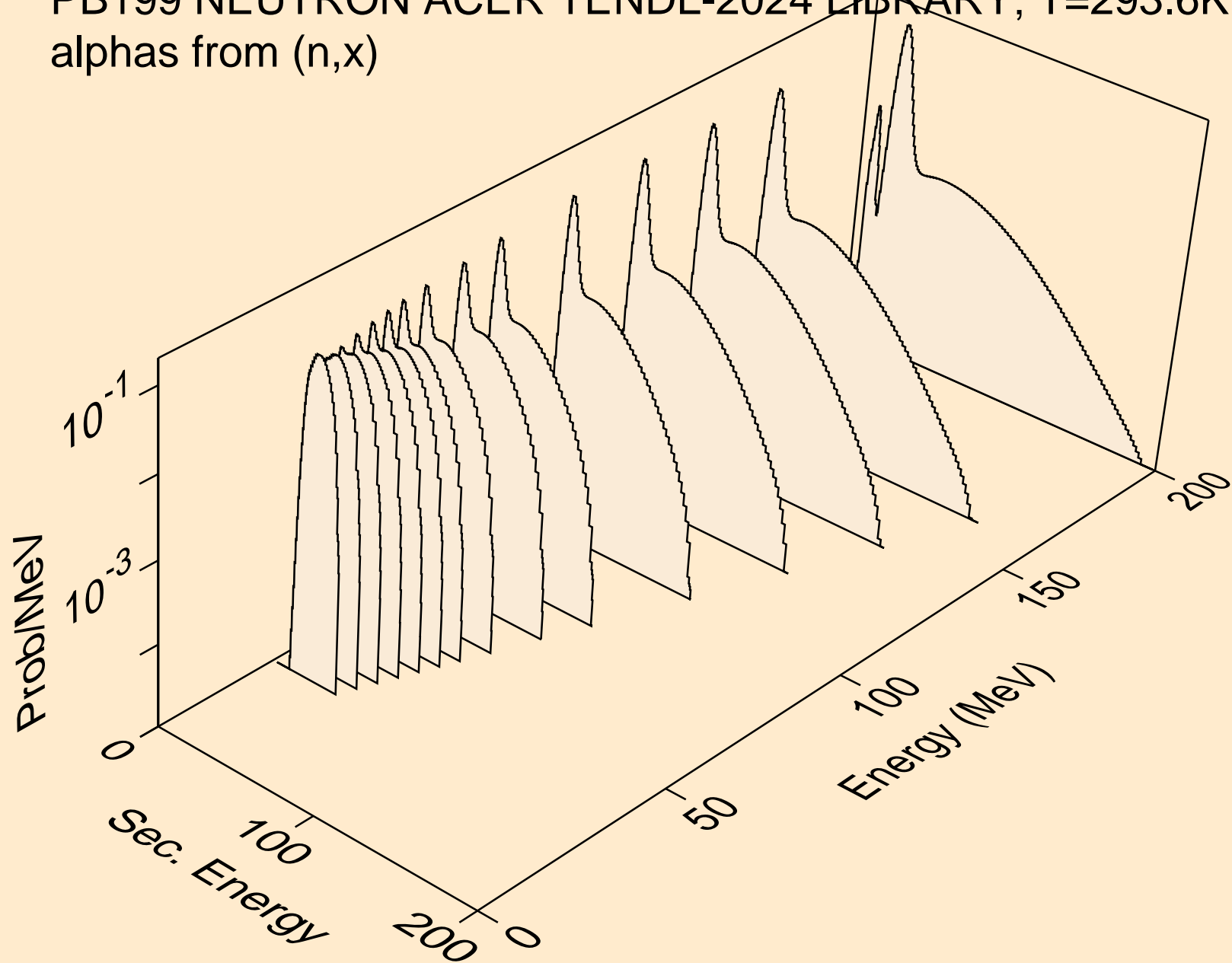

PB199 NEUTRON ACER TENDL-2024 LIBRARY; T=293.6K  
alphas from (n,n\*)a

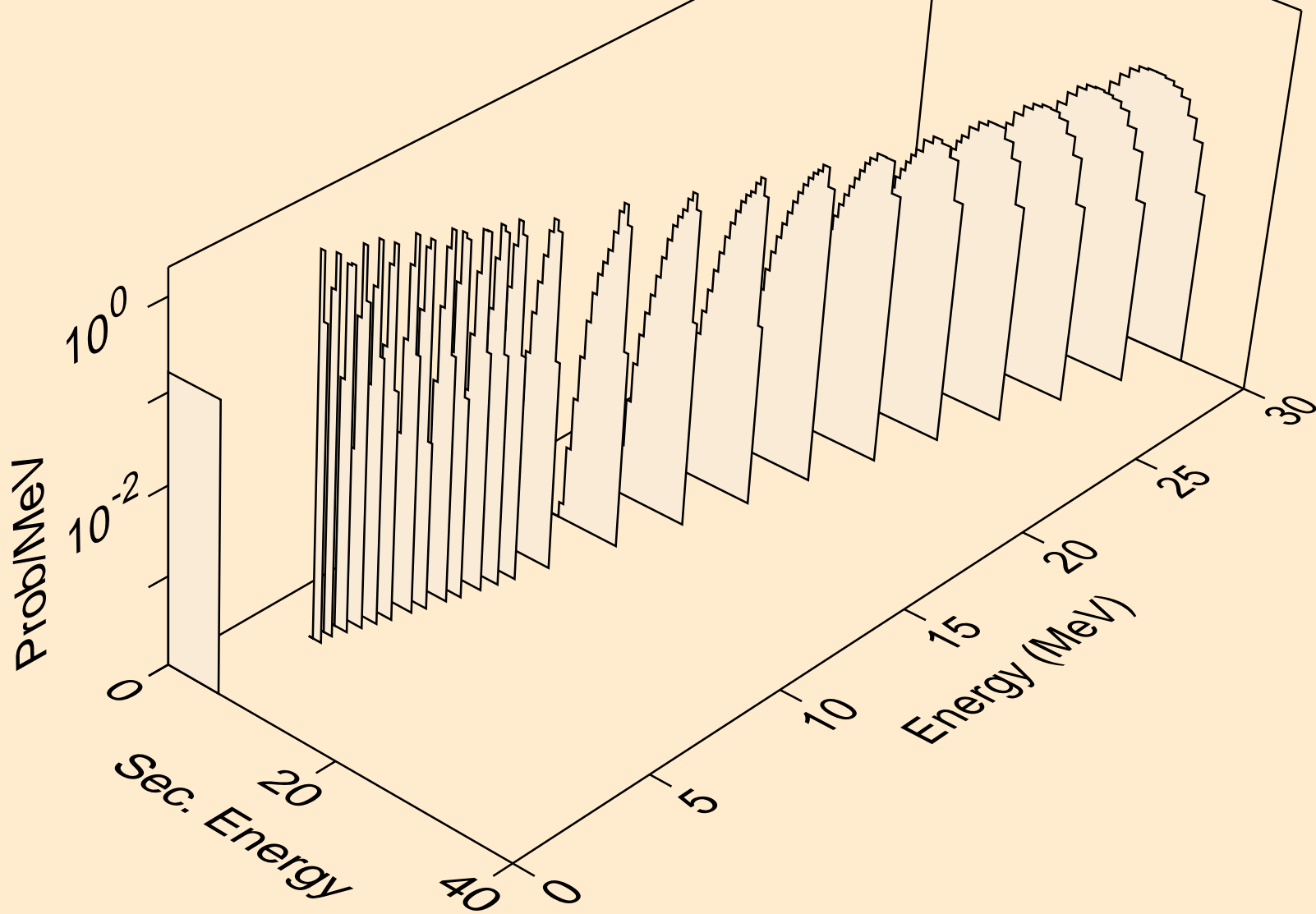

PB199 NEUTRON ACER TENDL-2024 LIBRARY; T=293.6K  
alphas from (n,2n)a

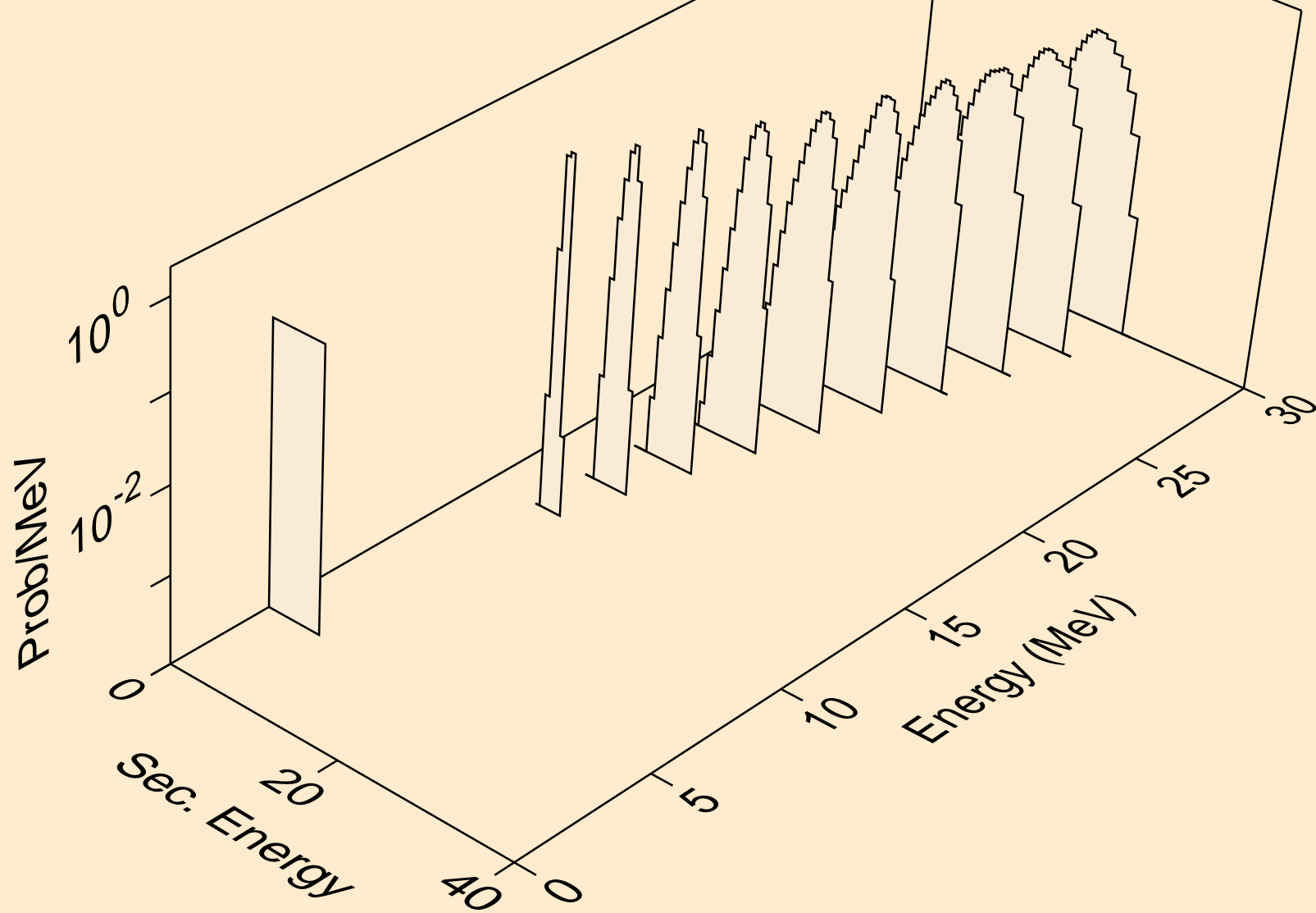

PB199 NEUTRON ACER TENDL-2024 LIBRARY; T=293.6K  
alphas from (n,3n)a

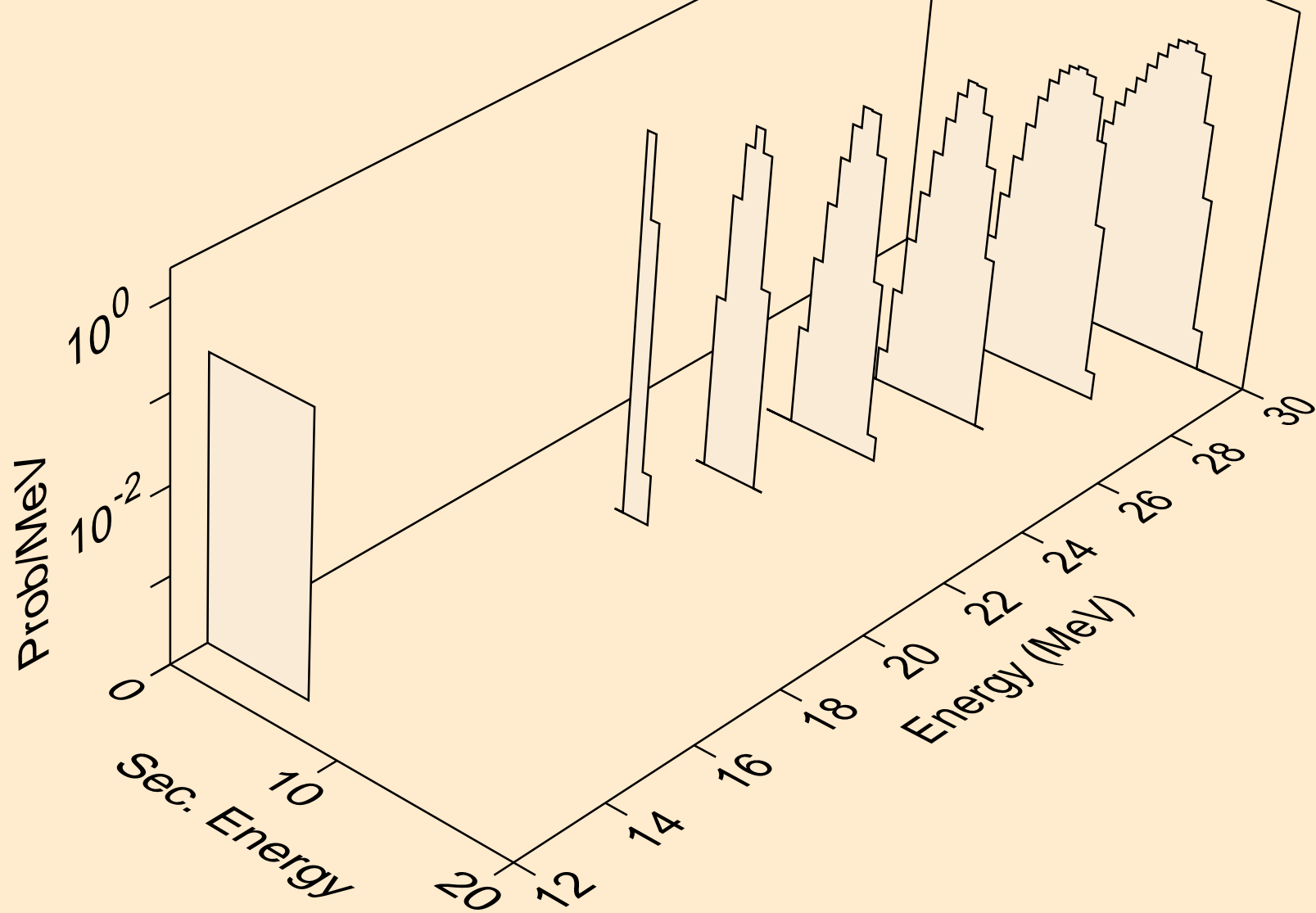

PB199 NEUTRON ACER TENDL-2024 LIBRARY; T=293.6K  
alphas from (n,n\*)2a

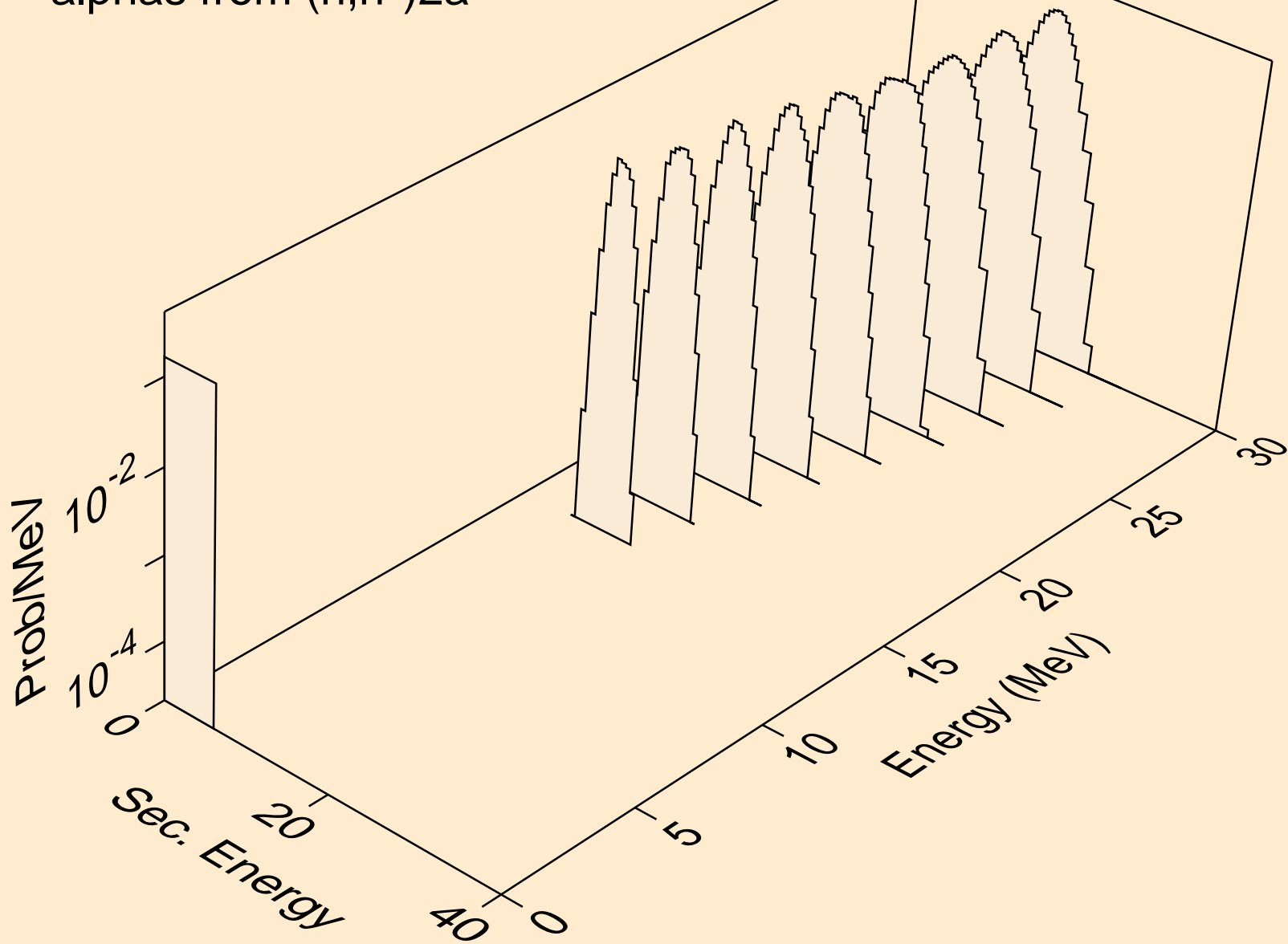

PB199 NEUTRON ACER TENDL-2024 LIBRARY; T=293.6K  
alphas from (n,npa)

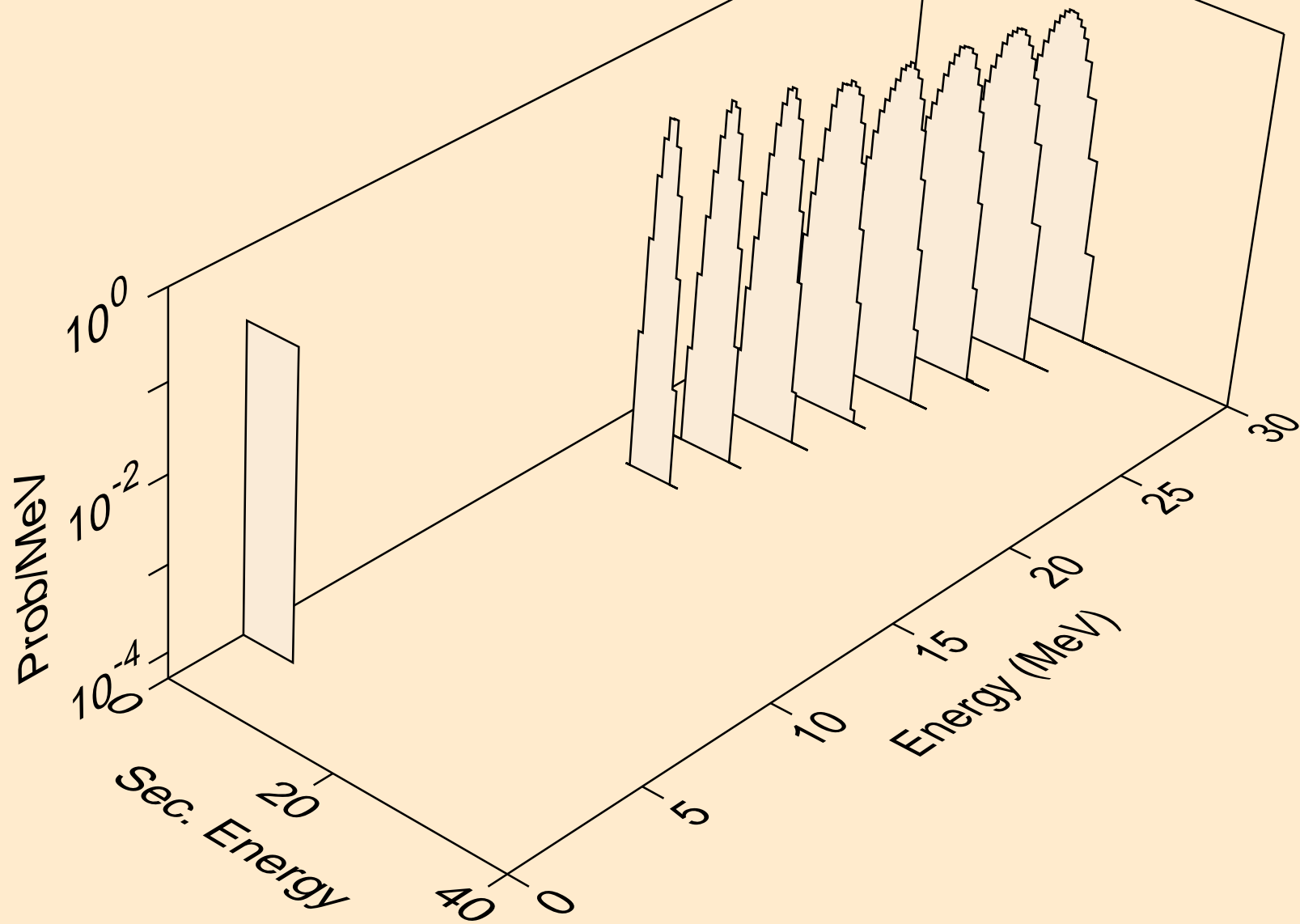

PB199 NEUTRON ACER TENDL-2024 LIBRARY; T=293.6K  
alphas from (n,a)

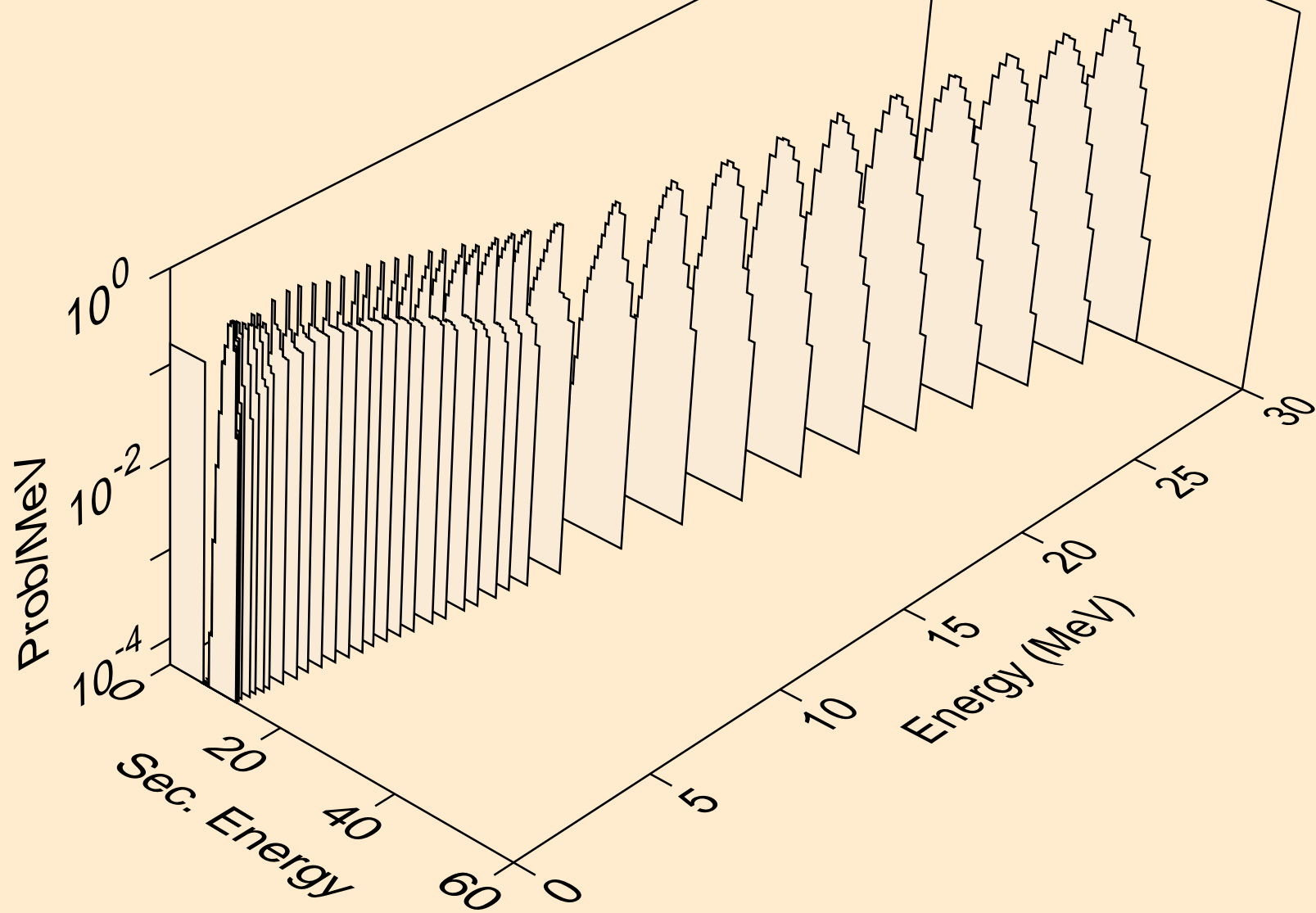

PB199 NEUTRON ACER TENDL-2024 LIBRARY; T=293.6K  
alphas from (n,2a)

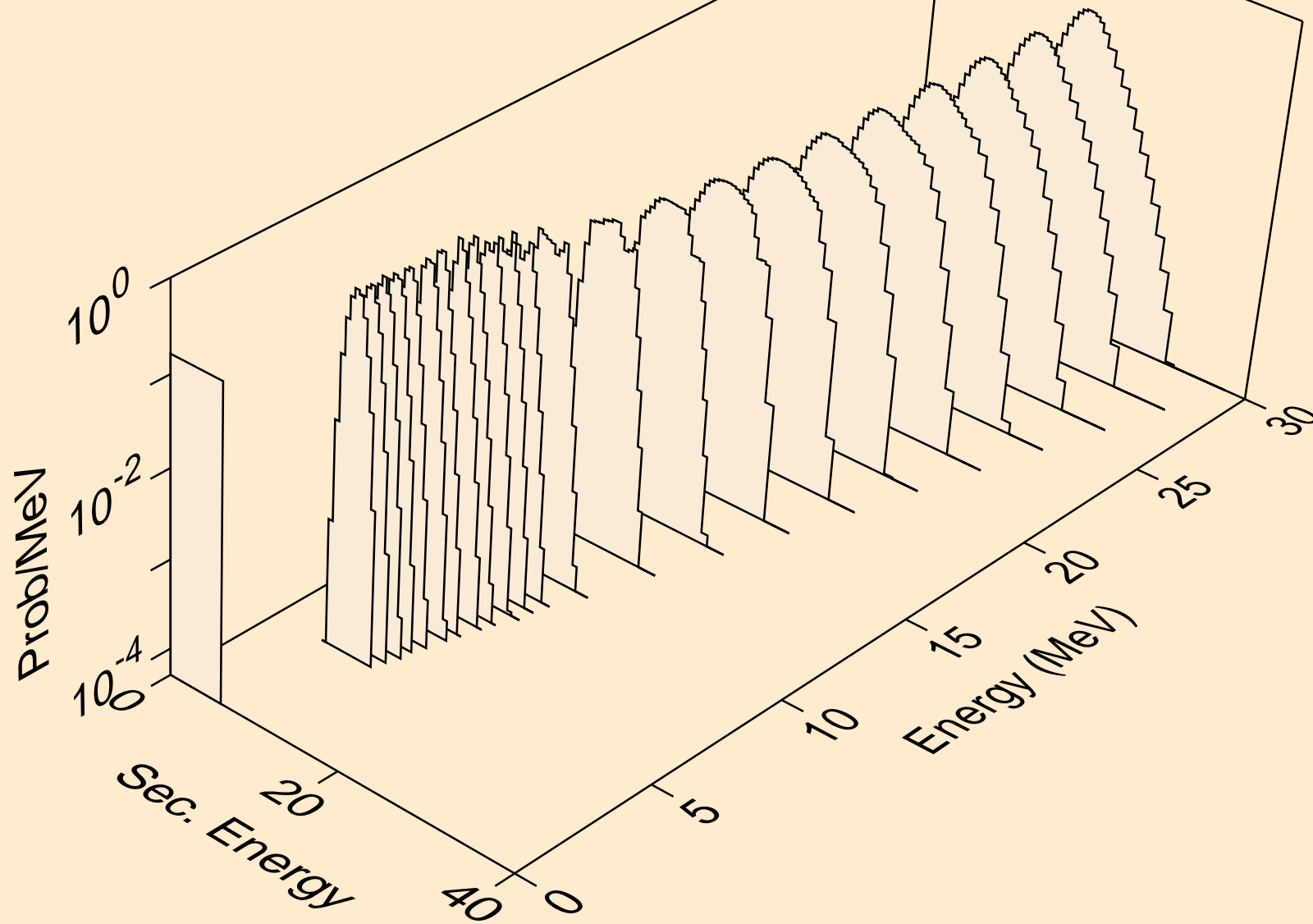

PB199 NEUTRON ACER TENDL-2024 LIBRARY; T=293.6K  
alphas from (n,pa)

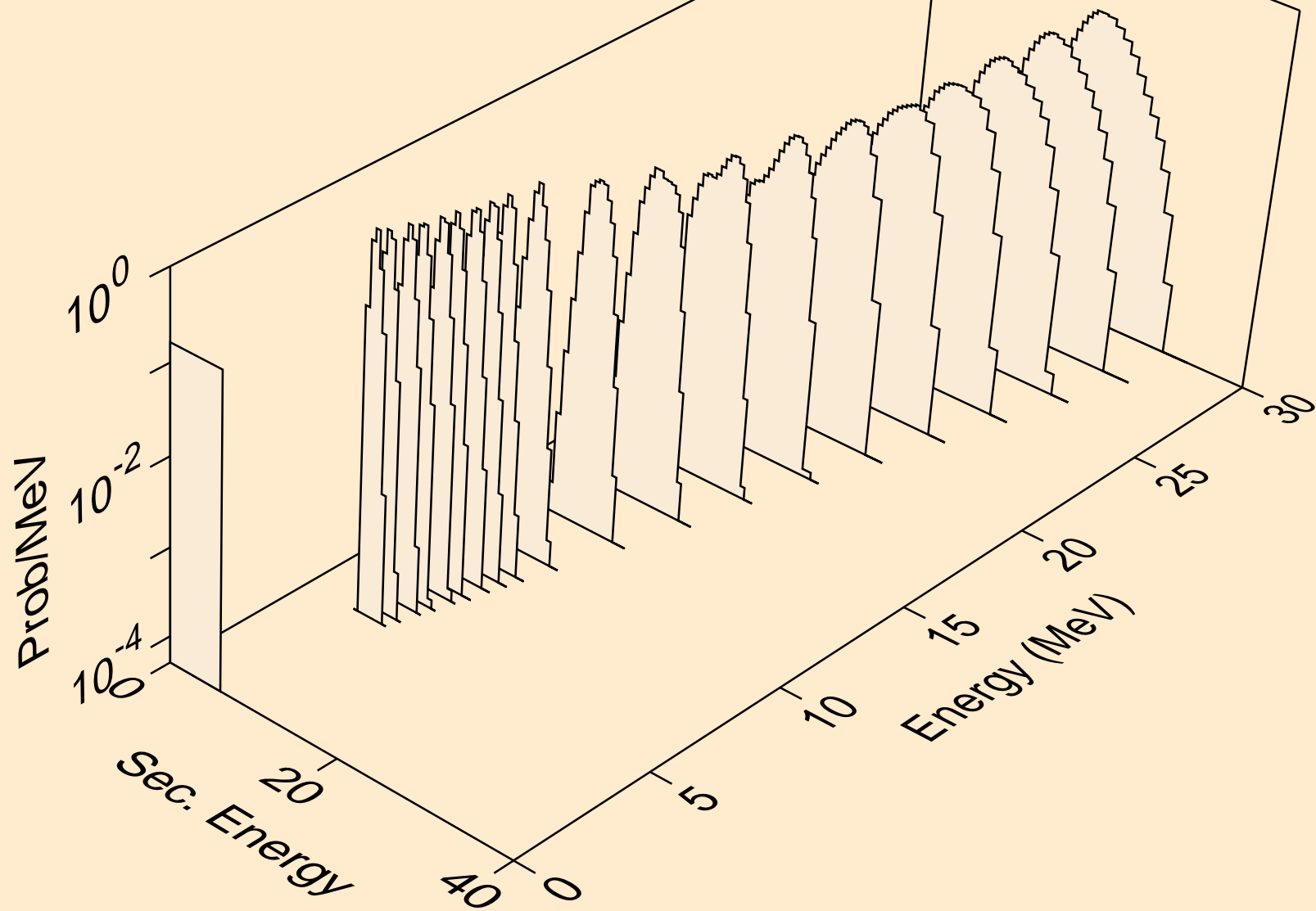

PB199 NEUTRON ACER TENDL-2024 LIBRARY; T=293.6K  
alphas from (n,da)

