

TM158 NEUTRON ACER TENDL-2024 LIBRARY; T=293.6K
Principal cross sections

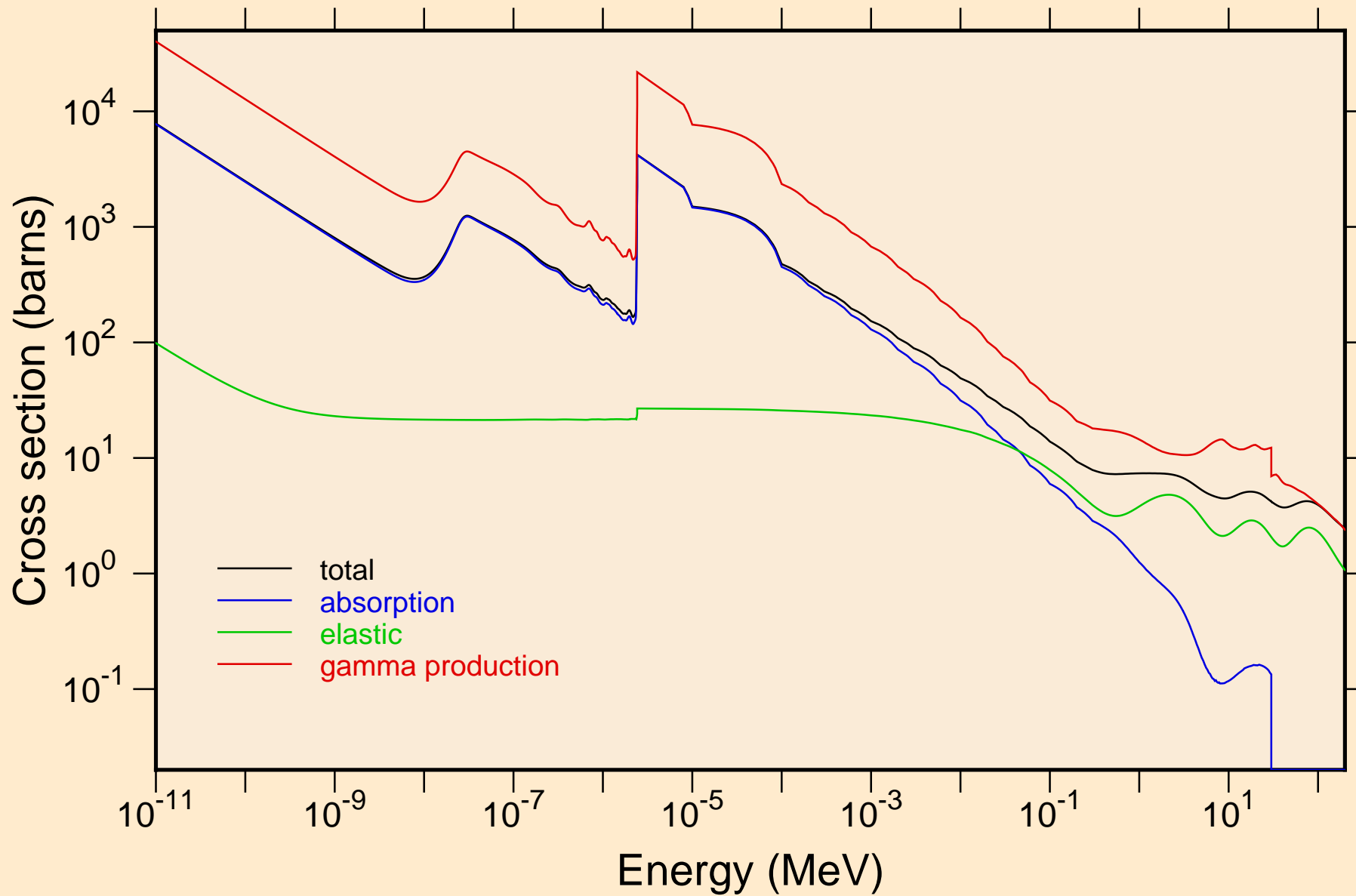

TM158 NEUTRON ACER TENDL-2024 LIBRARY; T=293.6K
resonance total cross section

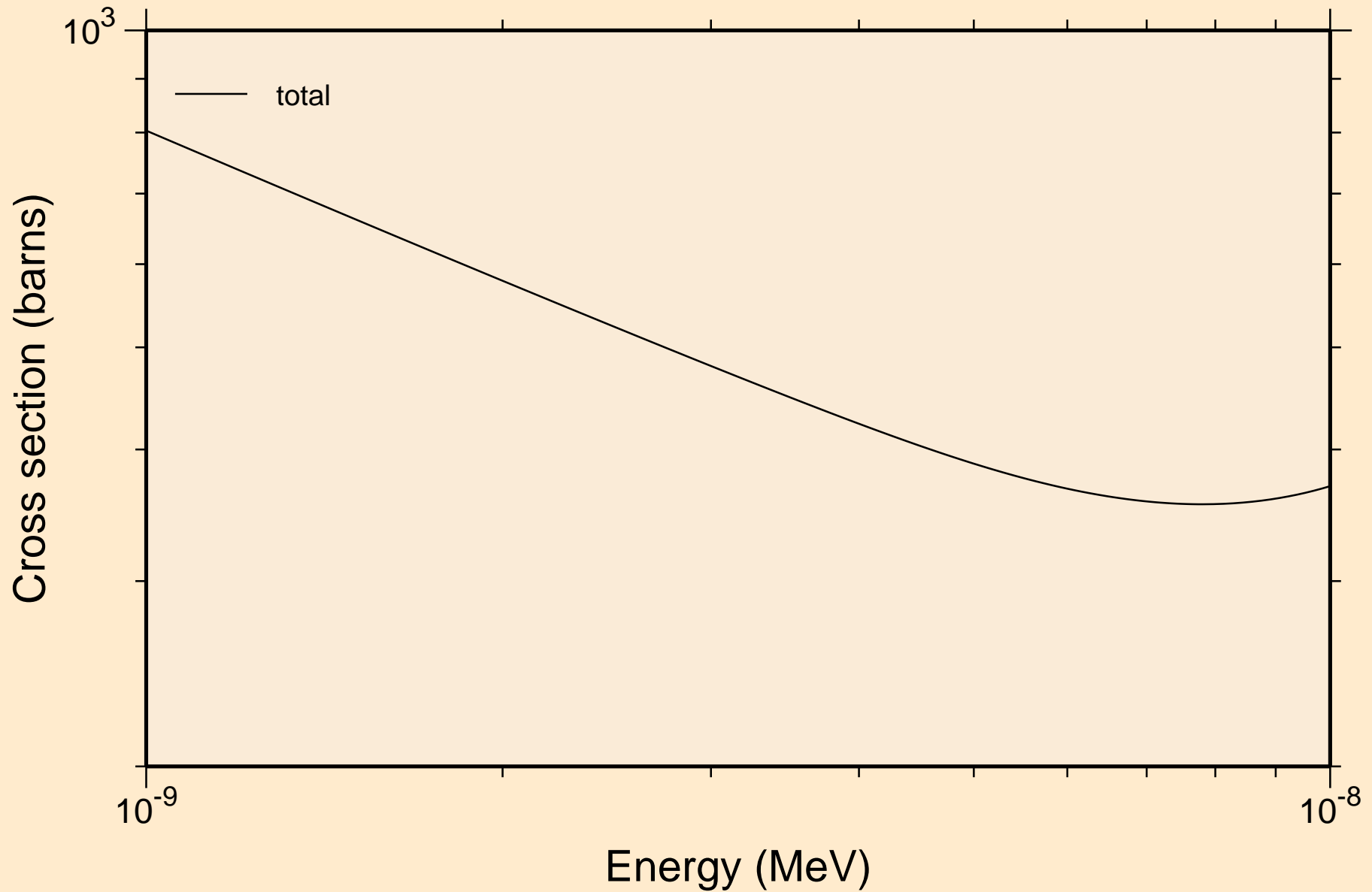

TM158 NEUTRON ACER TENDL-2024 LIBRARY; T=293.6K
resonance total cross section

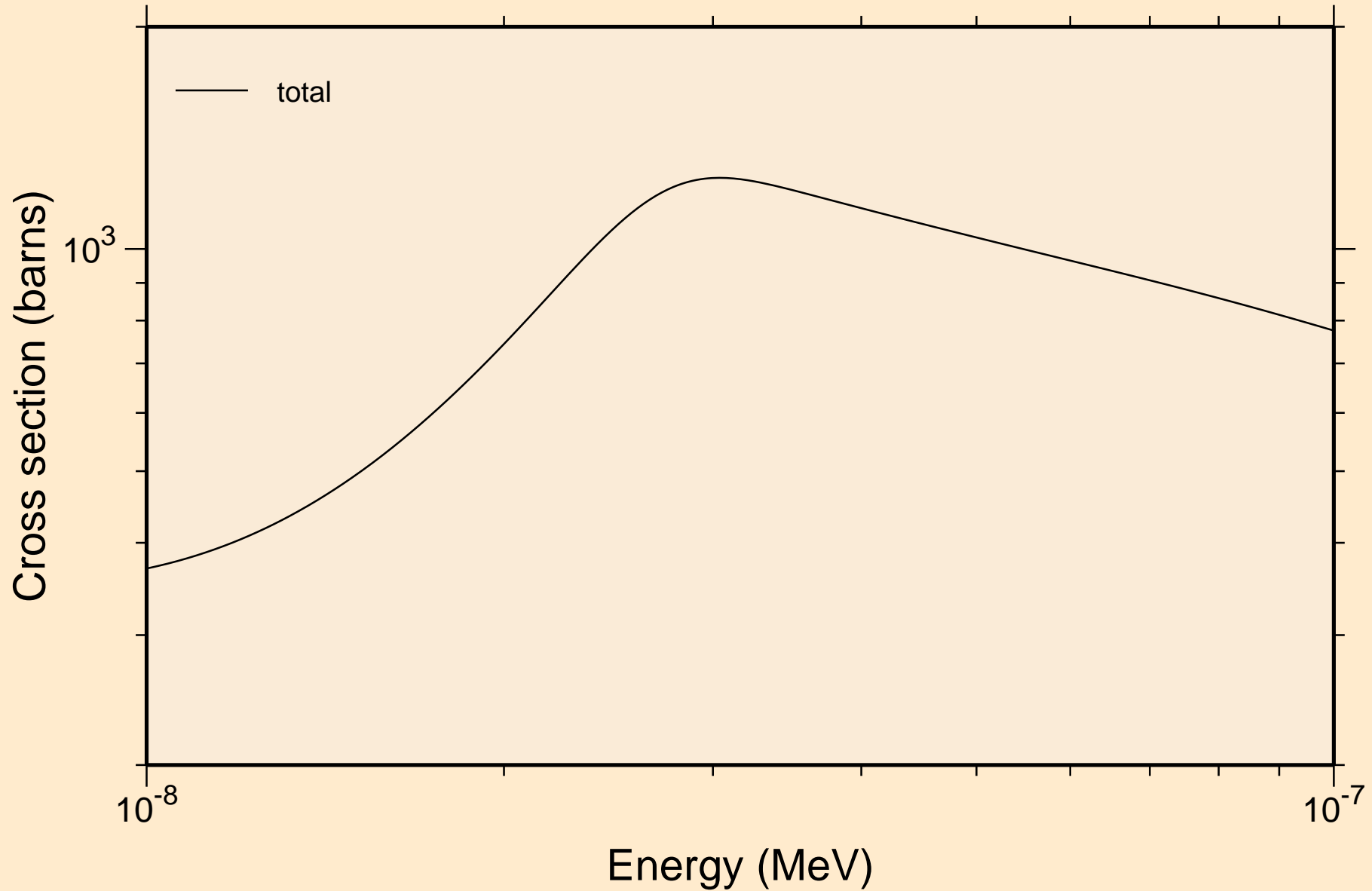

TM158 NEUTRON ACER TENDL-2024 LIBRARY; T=293.6K
resonance total cross section

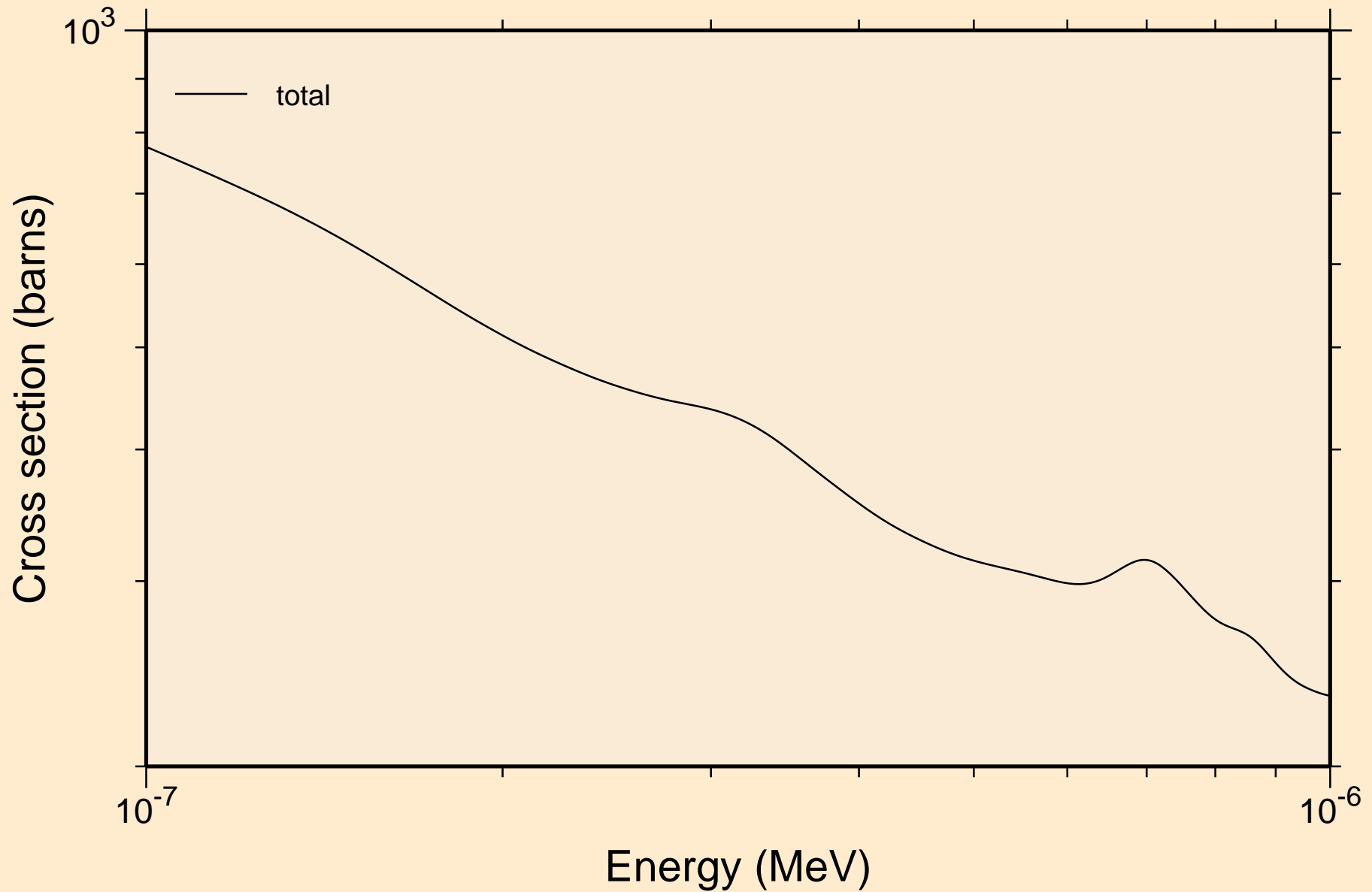

TM158 NEUTRON ACER TENDL-2024 LIBRARY; T=293.6K
resonance total cross section

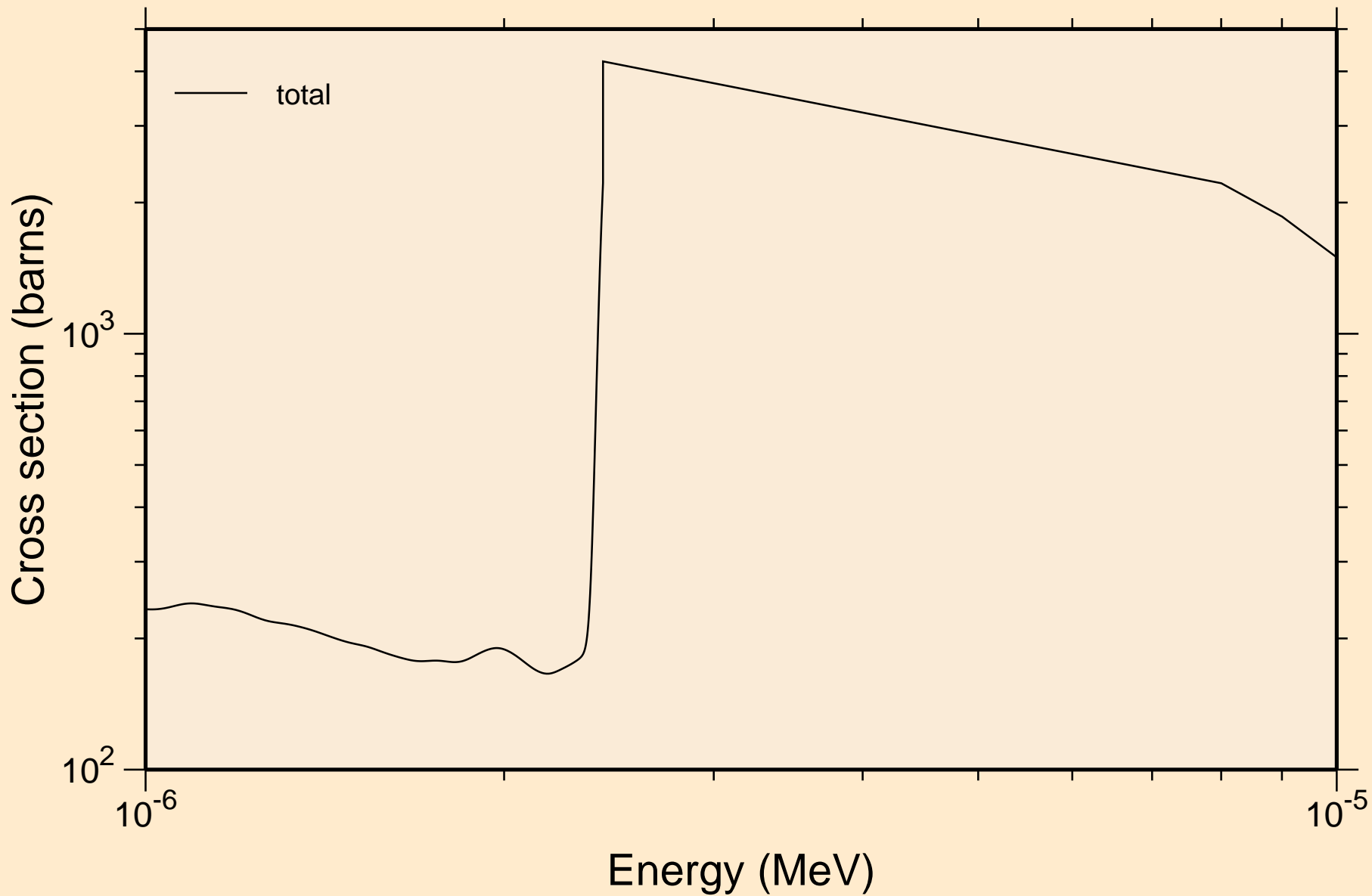

TM158 NEUTRON ACER TENDL-2024 LIBRARY; T=293.6K
resonance total cross section

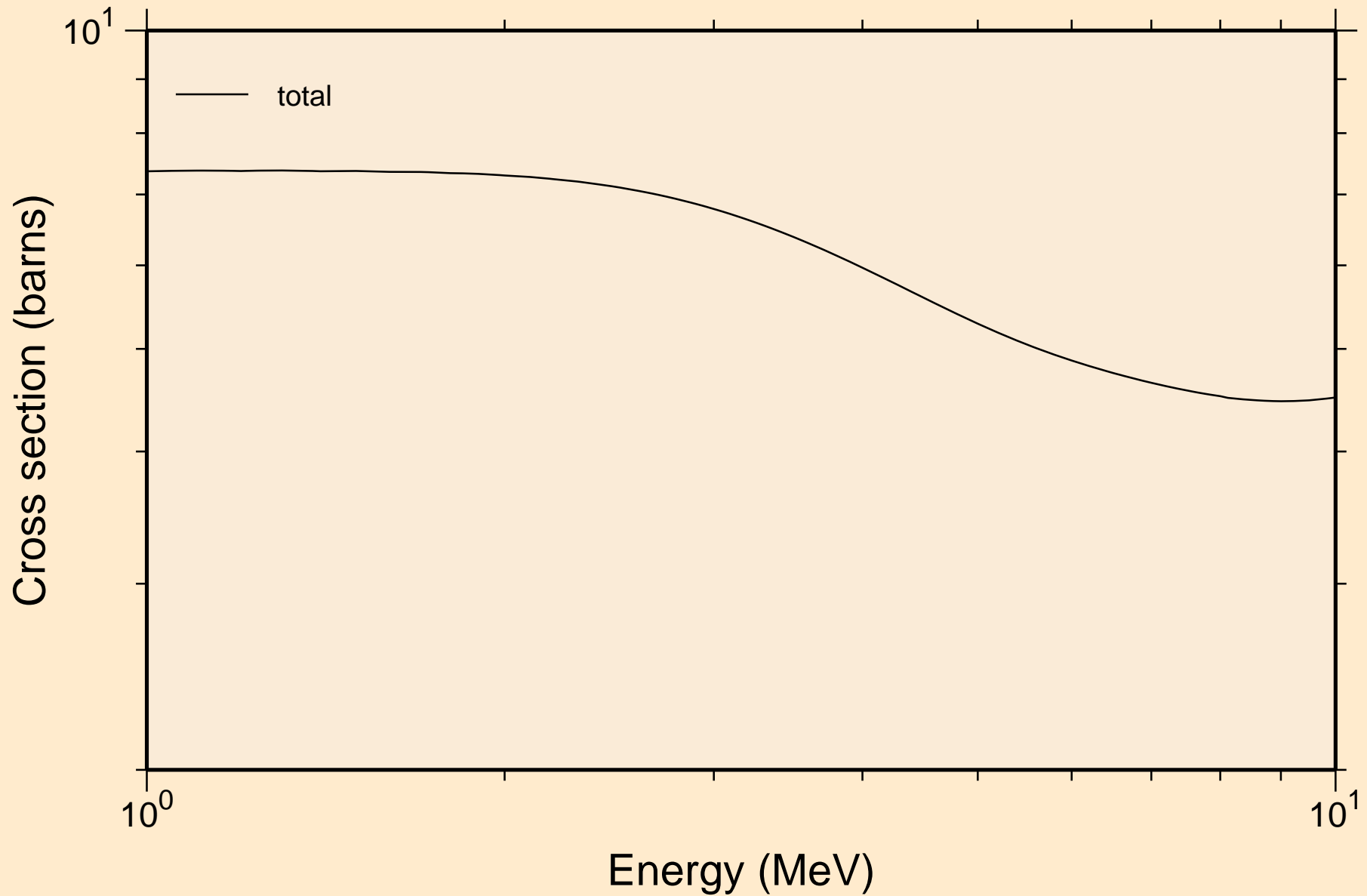

TM158 NEUTRON ACER TENDL-2024 LIBRARY; T=293.6K
resonance absorption cross sections

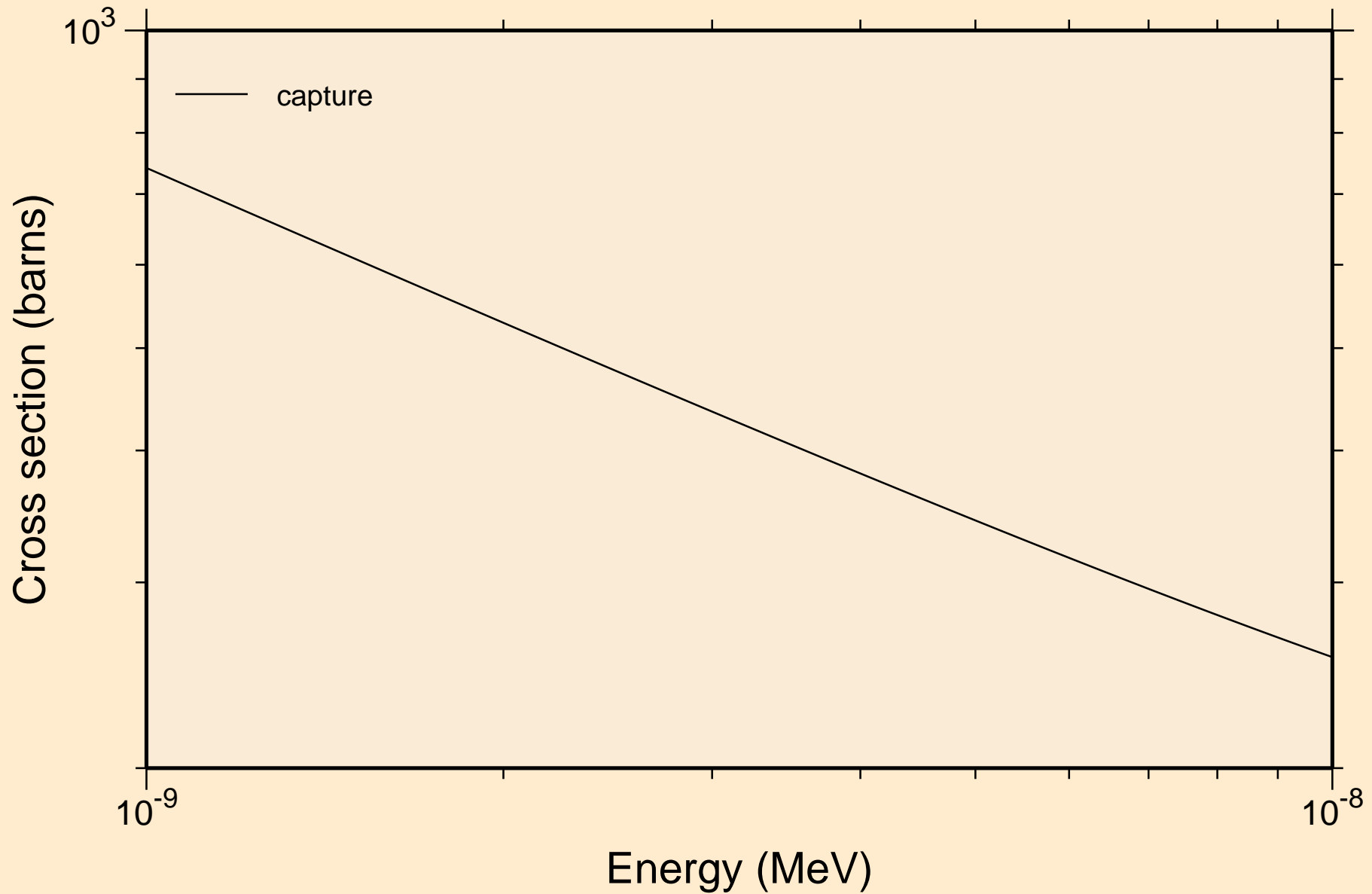

TM158 NEUTRON ACER TENDL-2024 LIBRARY; T=293.6K
resonance absorption cross sections

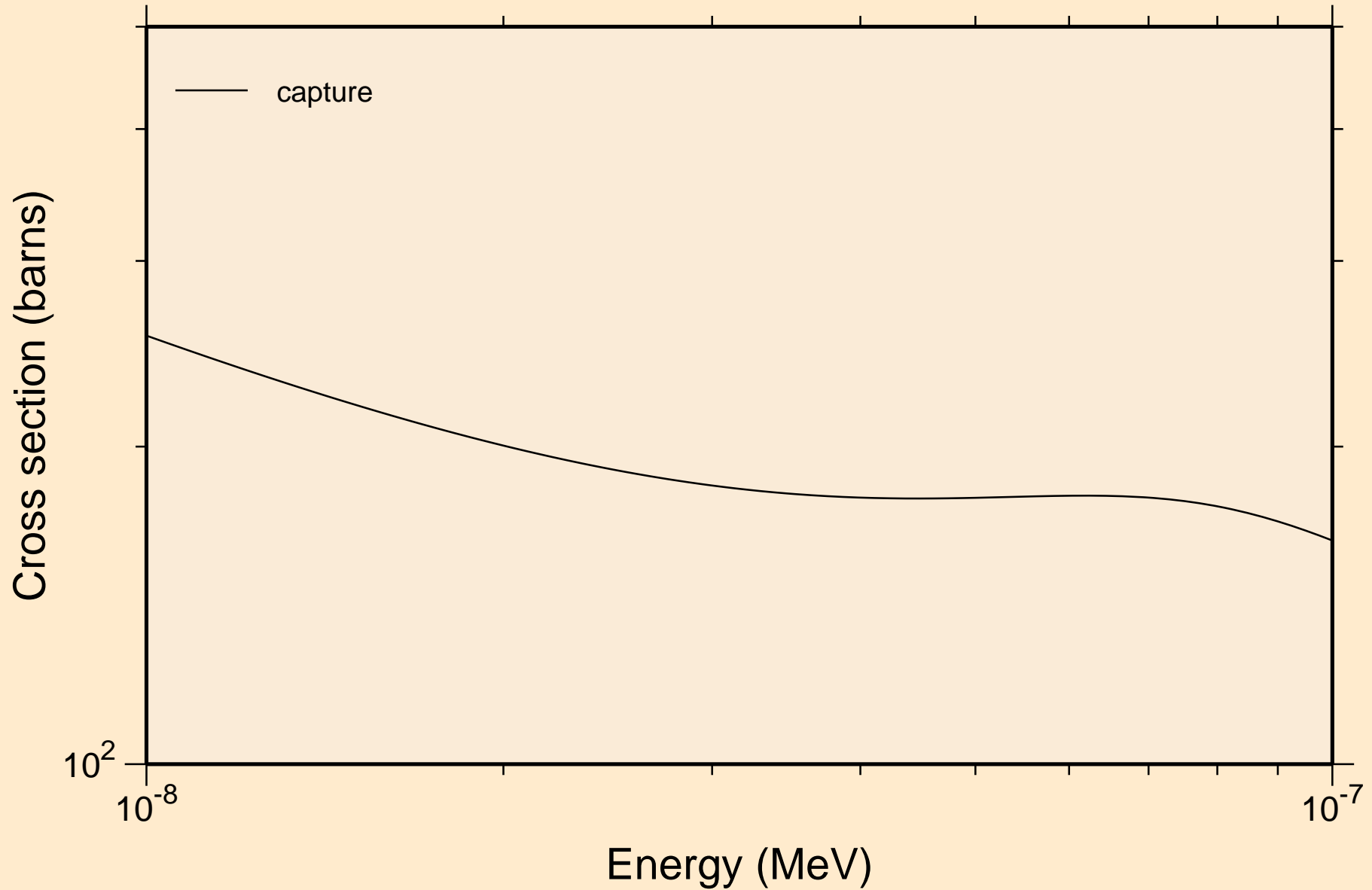

TM158 NEUTRON ACER TENDL-2024 LIBRARY; T=293.6K
resonance absorption cross sections

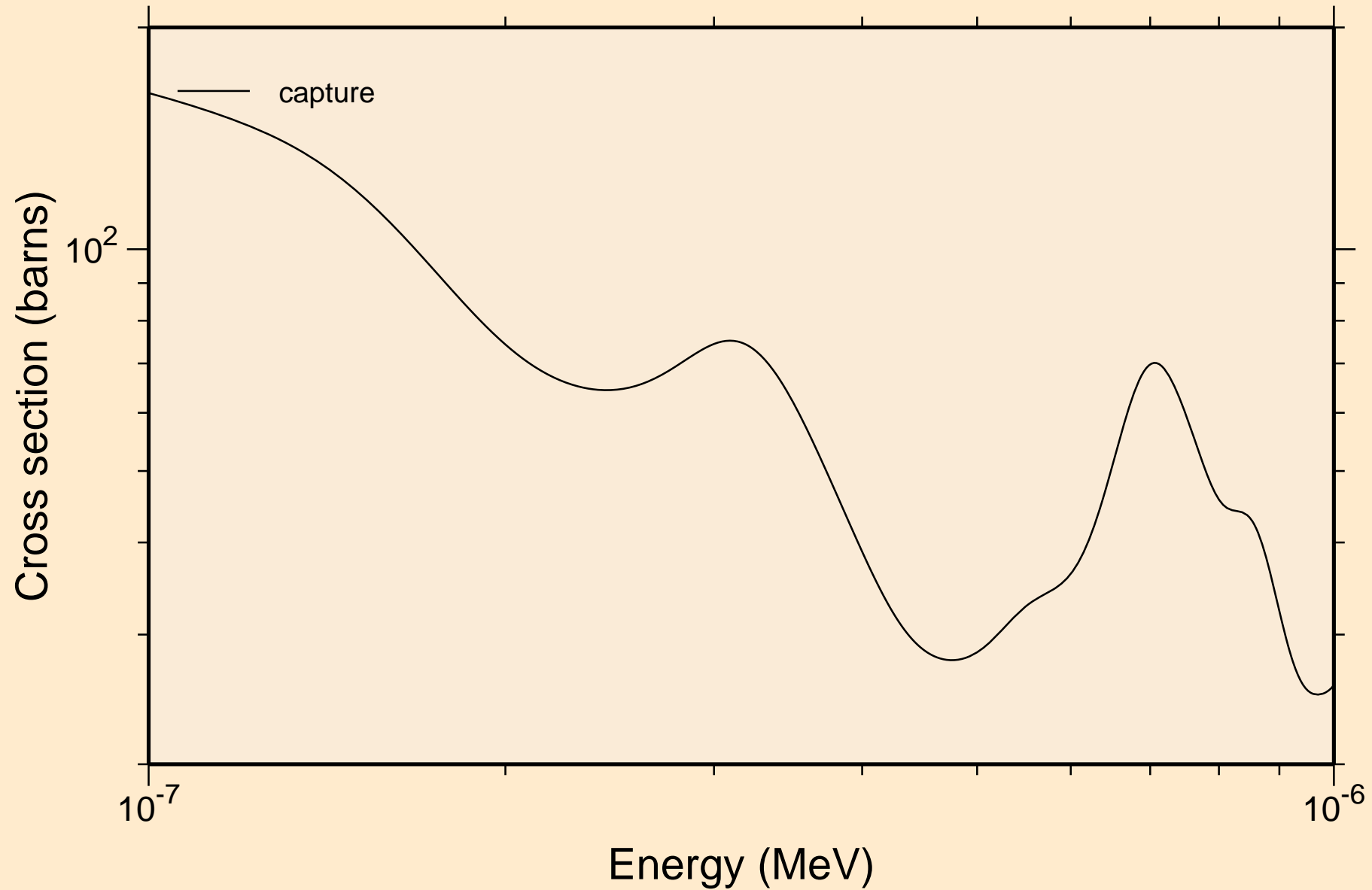

TM158 NEUTRON ACER TENDL-2024 LIBRARY; T=293.6K
resonance absorption cross sections

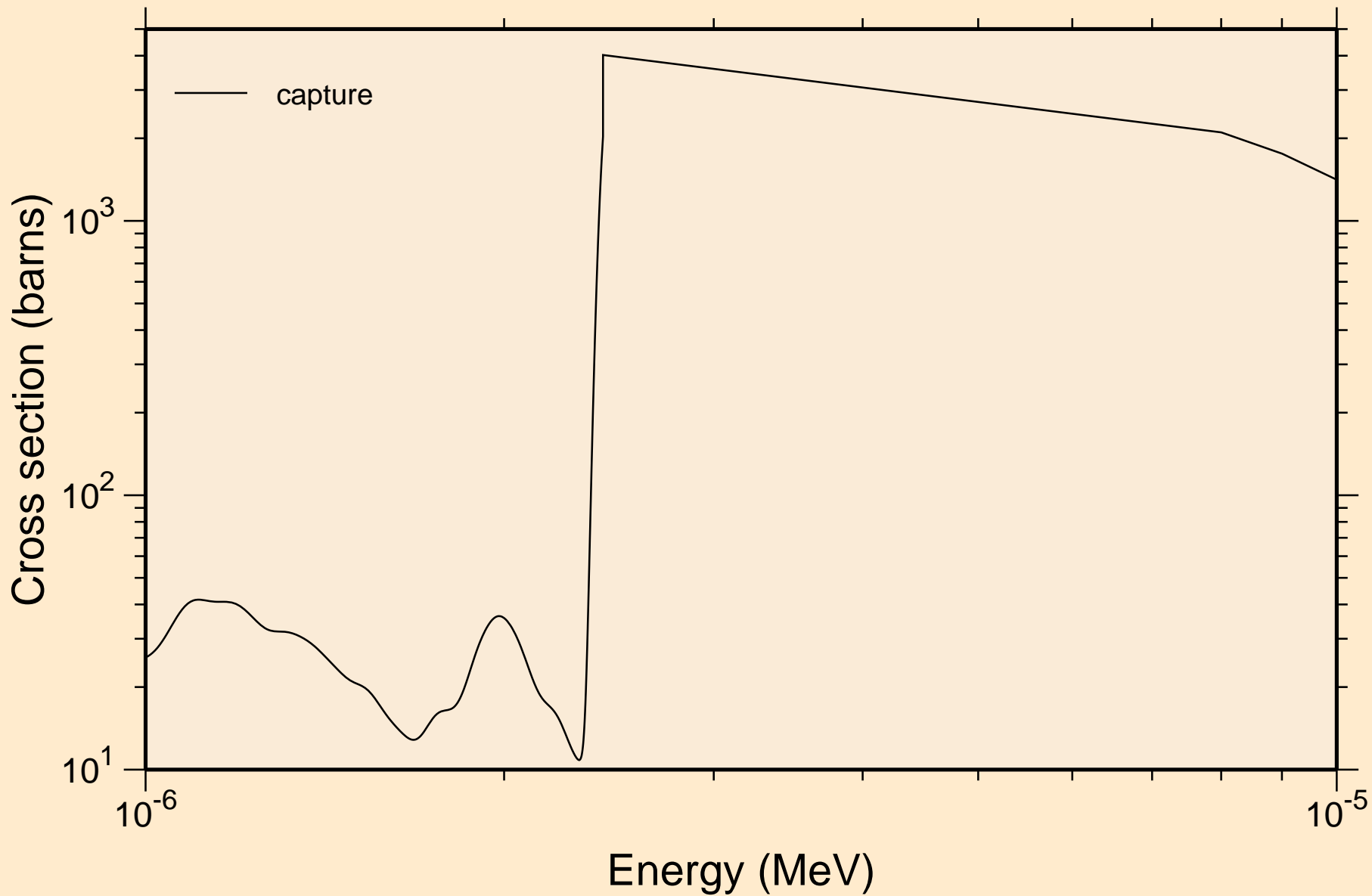

TM158 NEUTRON ACER TENDL-2024 LIBRARY; T=293.6K
resonance absorption cross sections

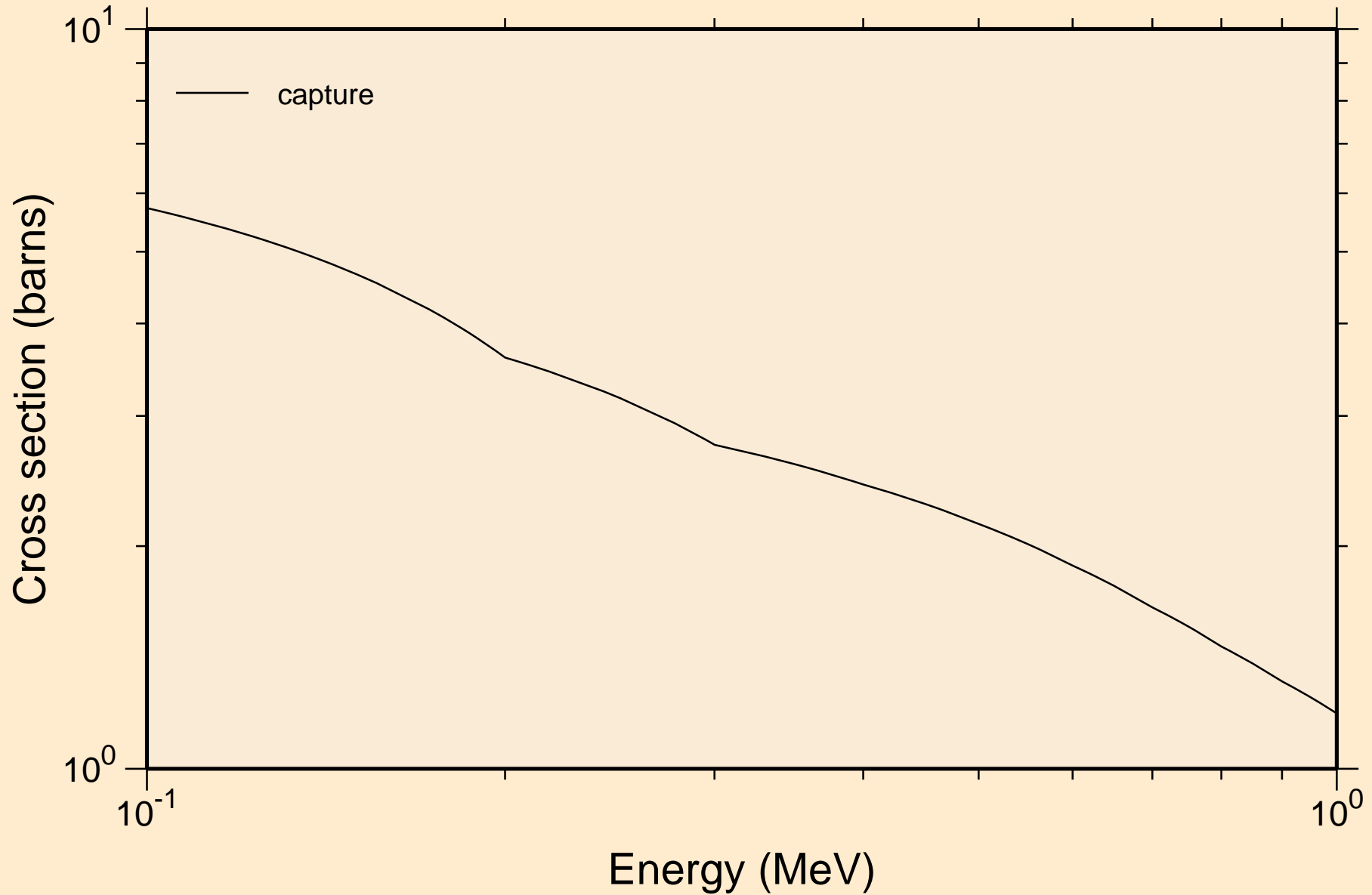

TM158 NEUTRON ACER TENDL-2024 LIBRARY; T=293.6K
resonance absorption cross sections

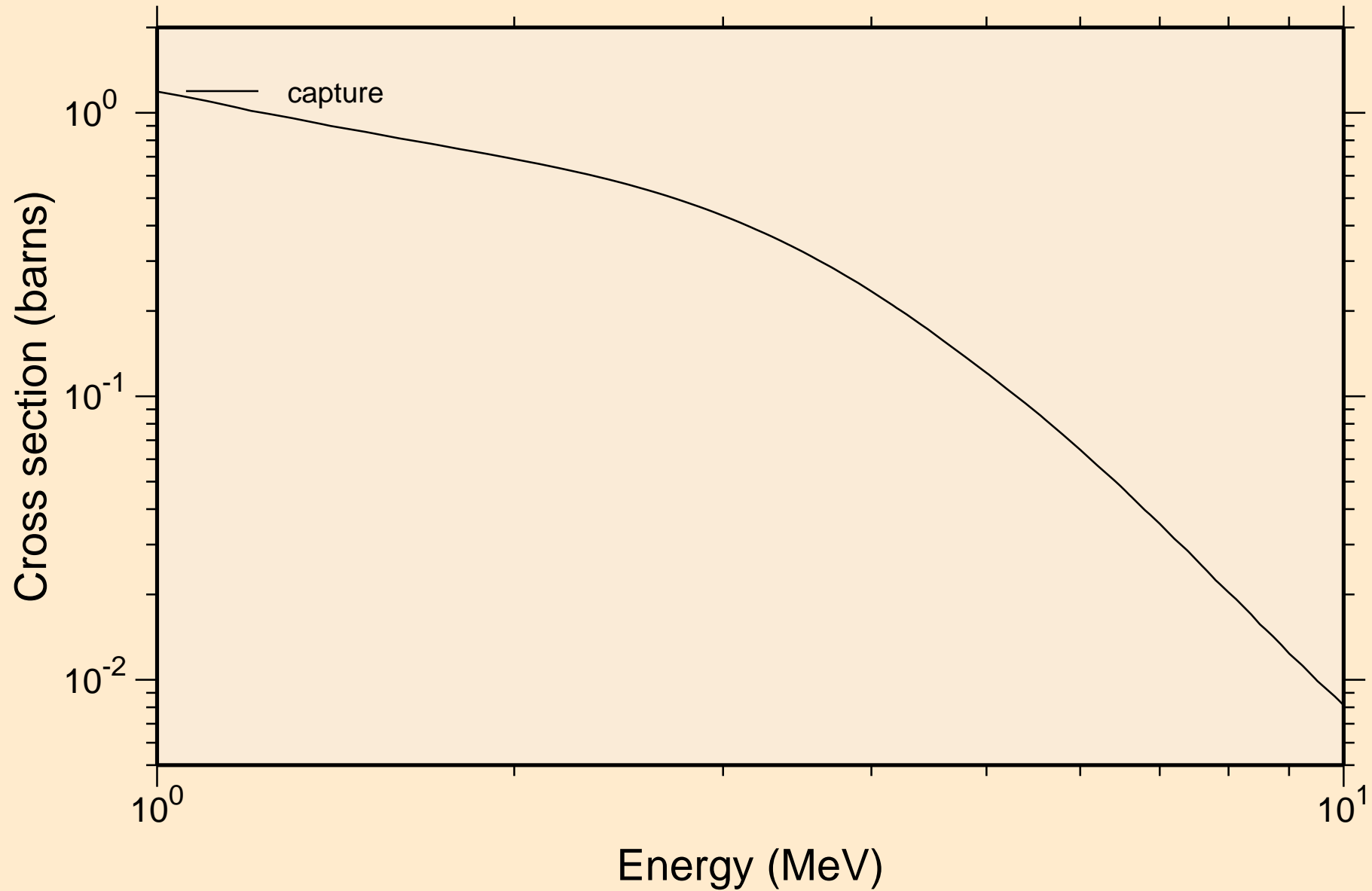

TM158 NEUTRON ACER TENDL-2024 LIBRARY; T=293.6K
Heating

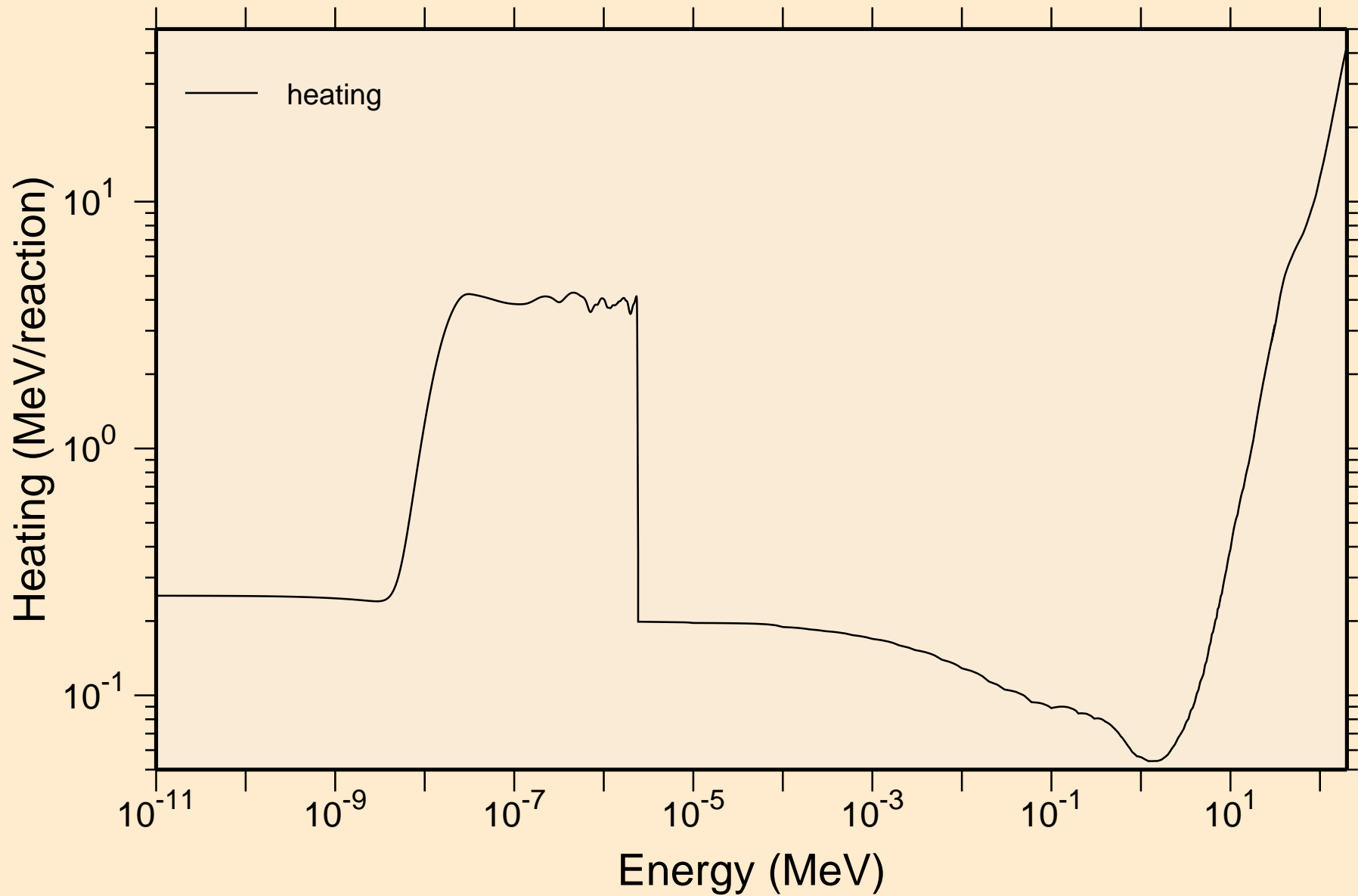

TM158 NEUTRON ACER TENDL-2024 LIBRARY; T=293.6K
Damage

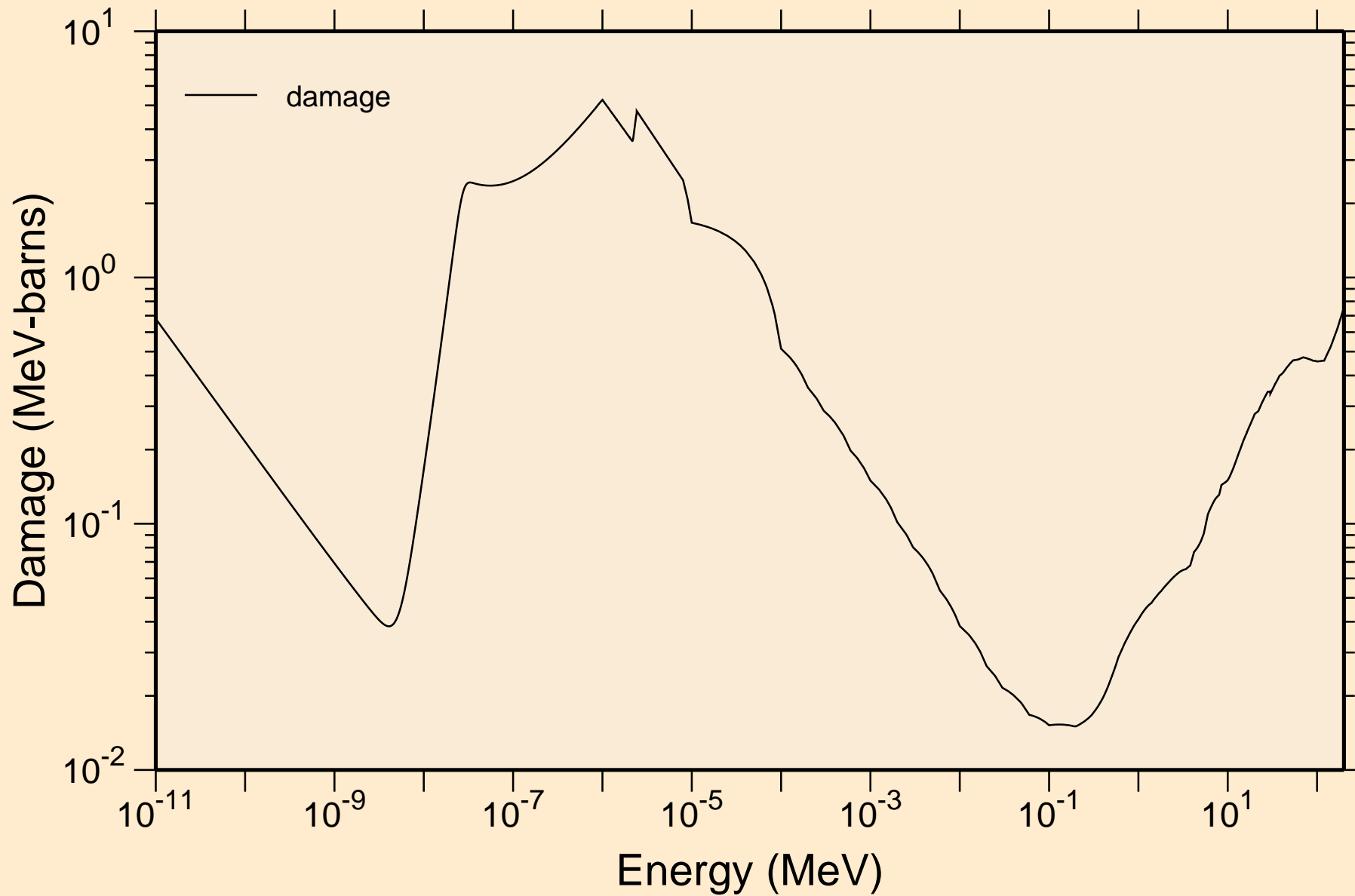

TM158 NEUTRON ACER TENDL-2024 LIBRARY; T=293.6K
Non-threshold reactions

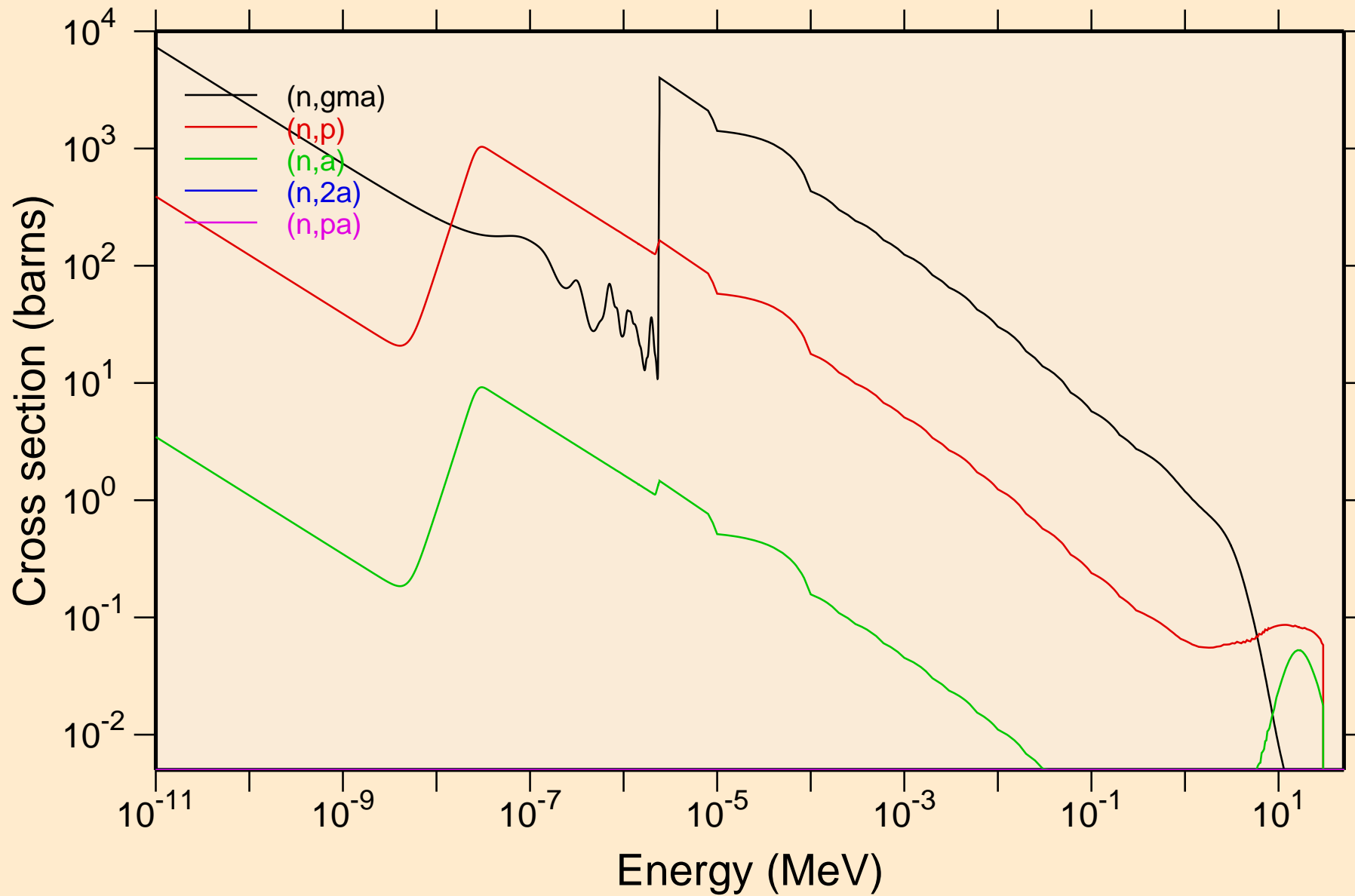

TM158 NEUTRON ACER TENDL-2024 LIBRARY; T=293.6K
Non-threshold reactions

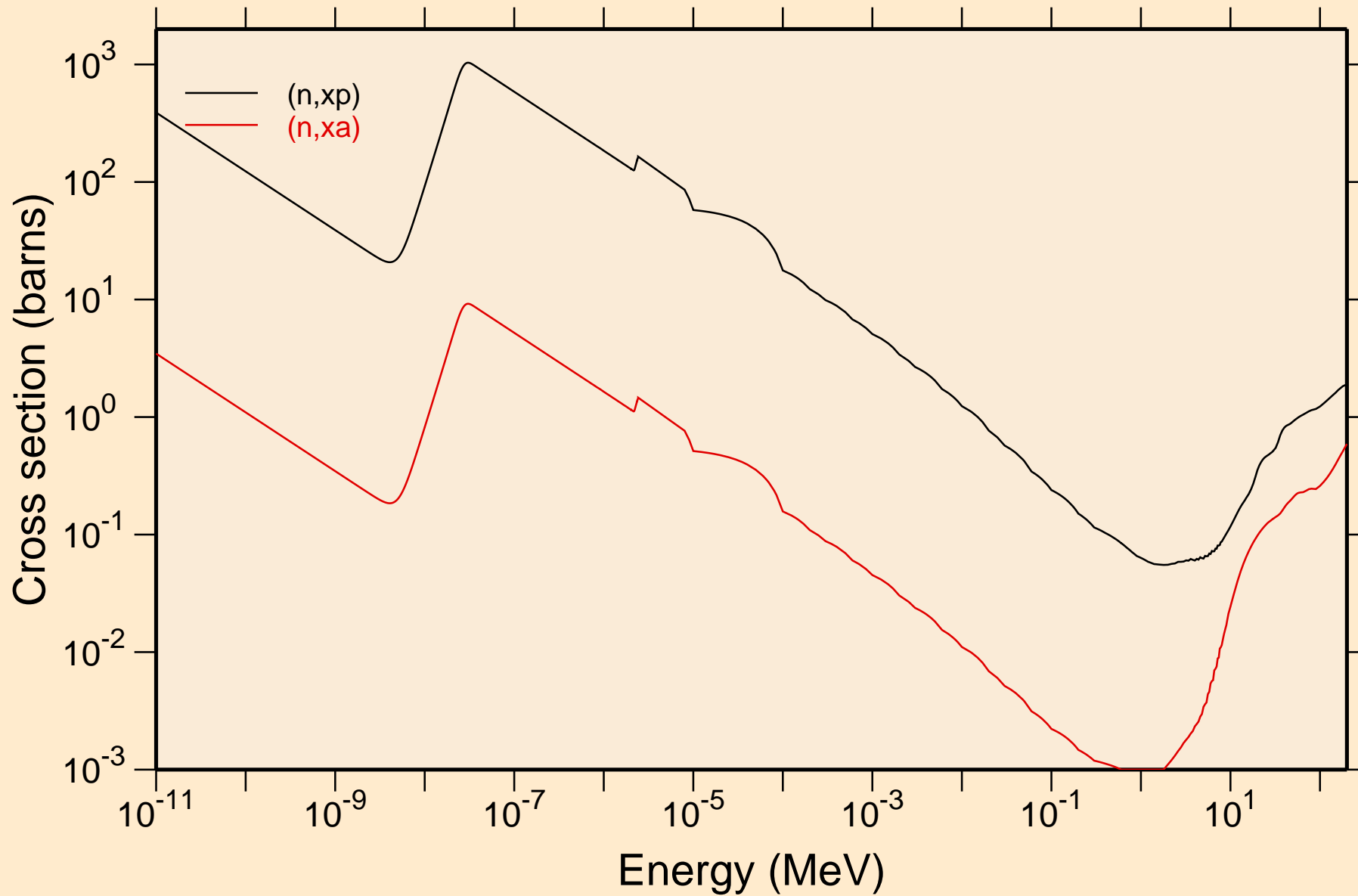

TM158 NEUTRON ACER TENDL-2024 LIBRARY; T=293.6K

Principal cross sections

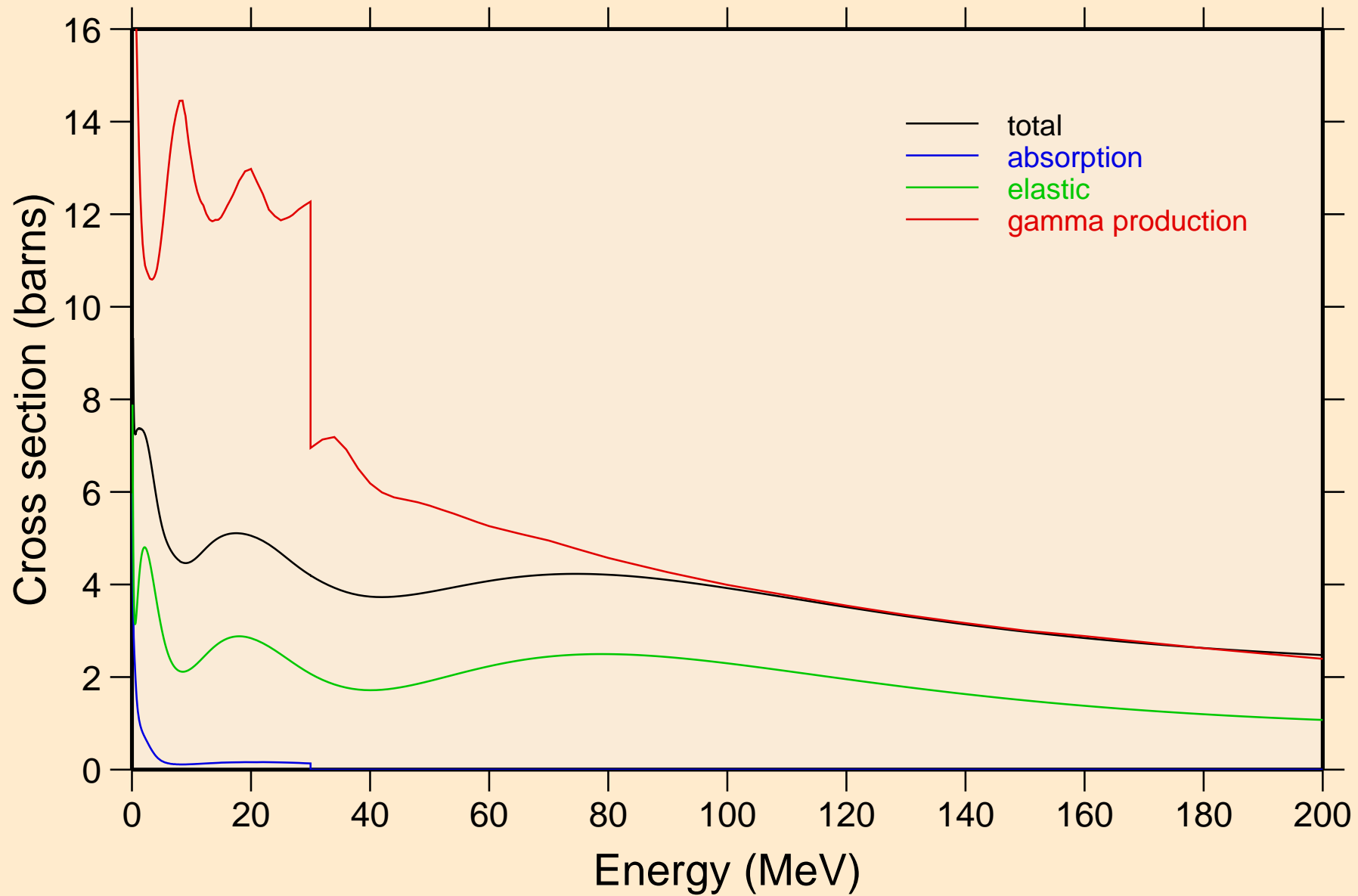

TM158 NEUTRON ACER TENDL-2024 LIBRARY; T=293.6K
Heating

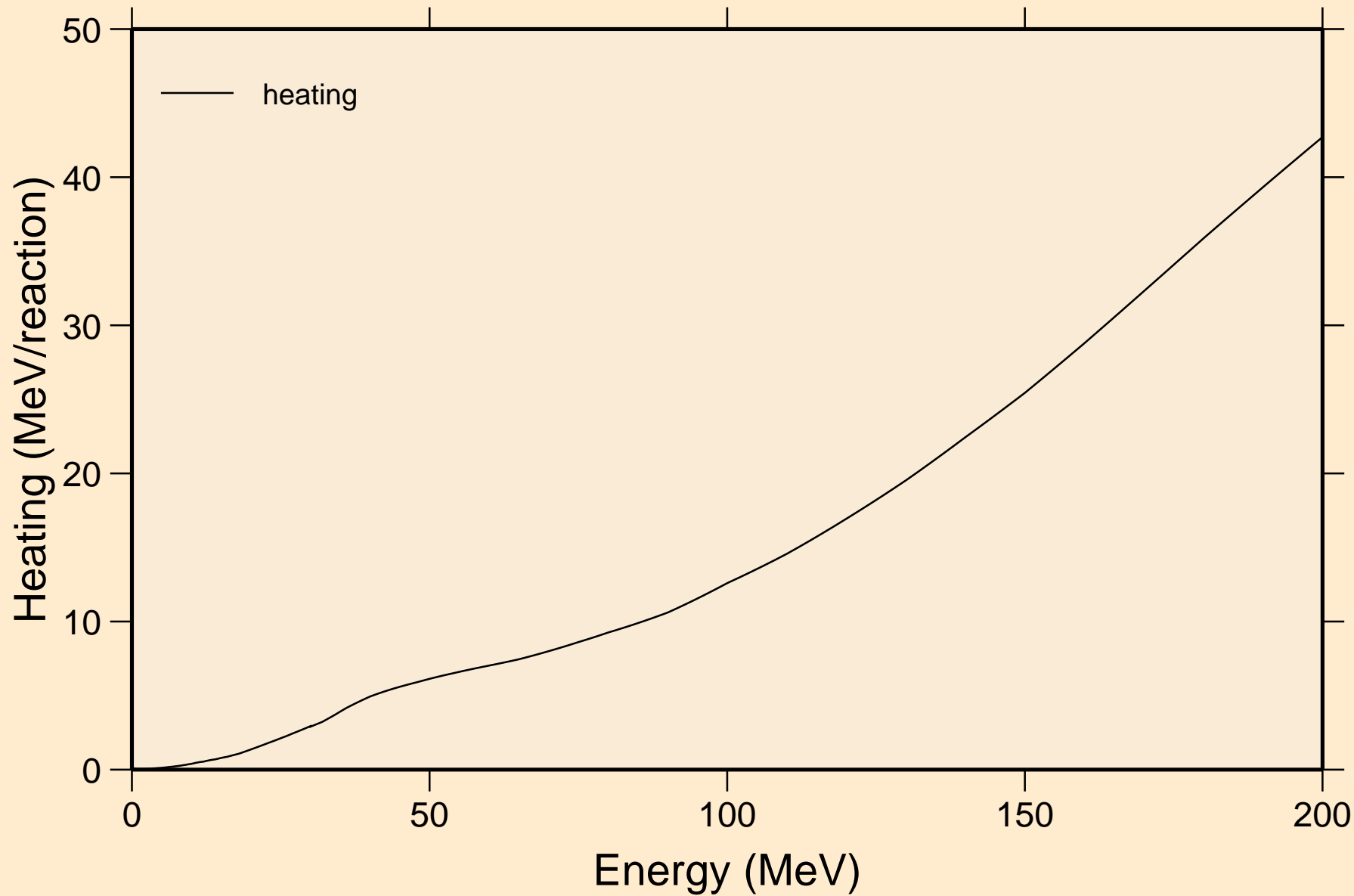

TM158 NEUTRON ACER TENDL-2024 LIBRARY; T=293.6K
Damage

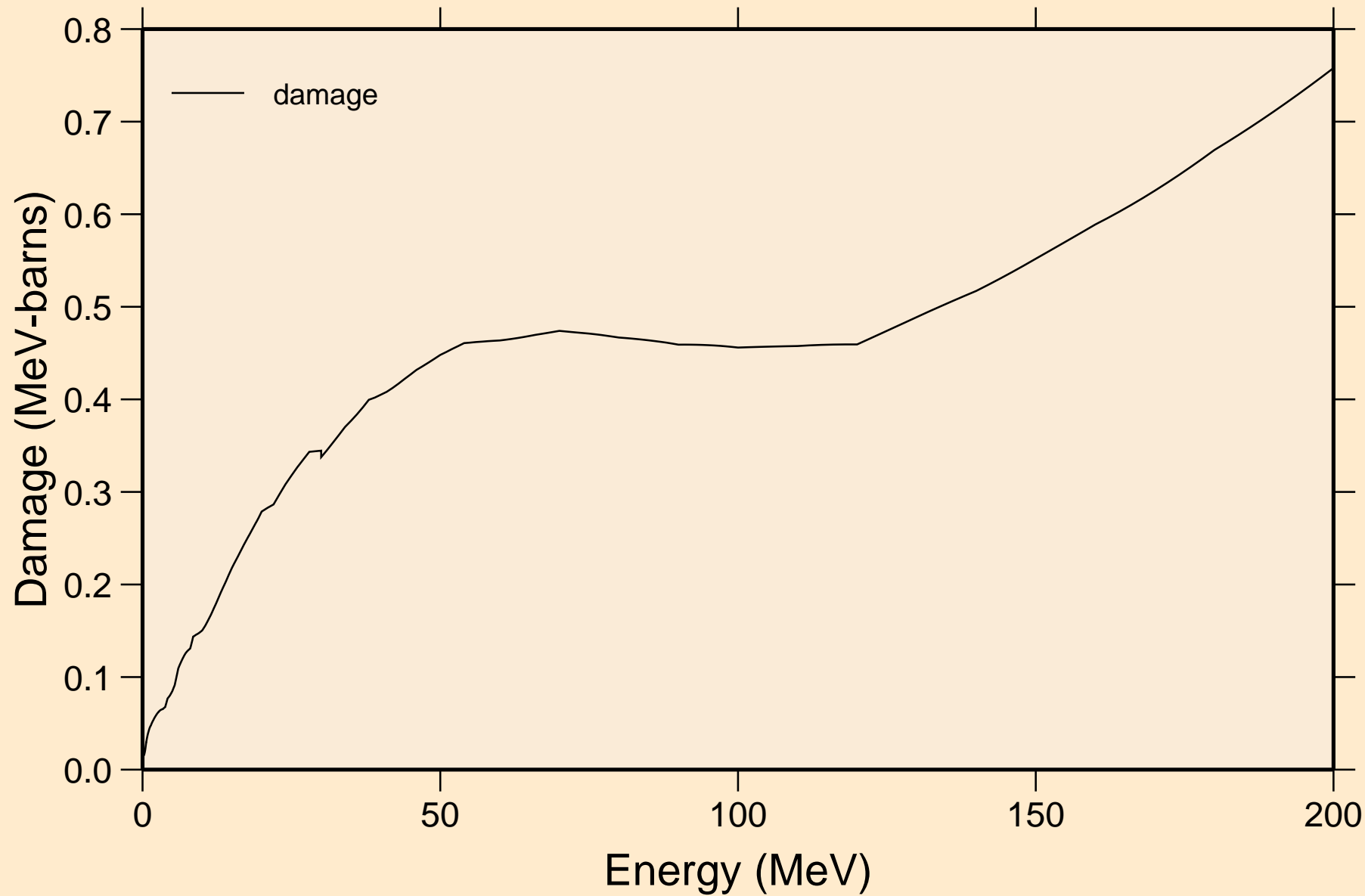

TM158 NEUTRON ACER TENDL-2024 LIBRARY; T=293.6K
Non-threshold reactions

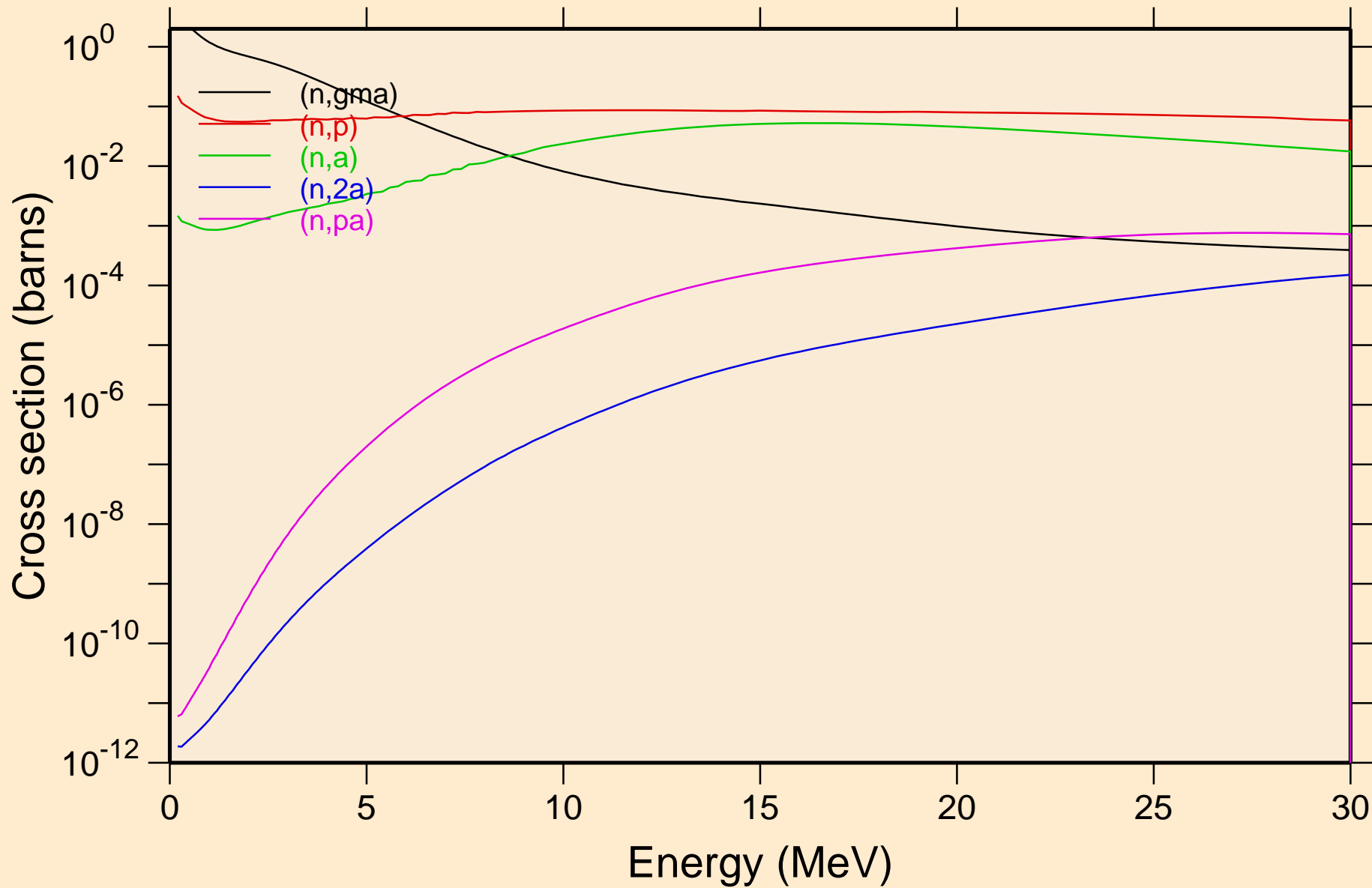

TM158 NEUTRON ACER TENDL-2024 LIBRARY; T=293.6K
Non-threshold reactions

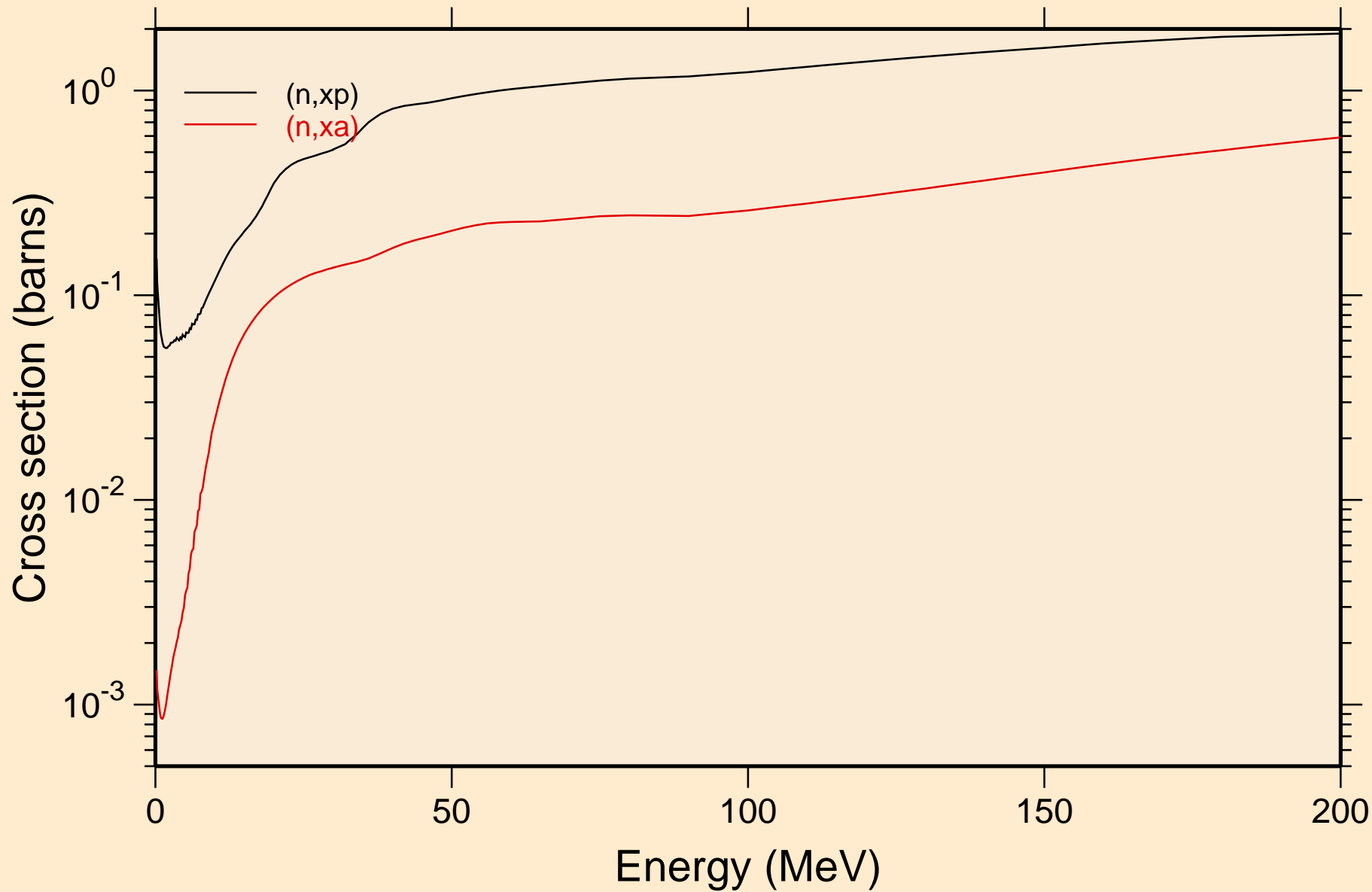

TM158 NEUTRON ACER TENDL-2024 LIBRARY; T=293.6K
Inelastic levels

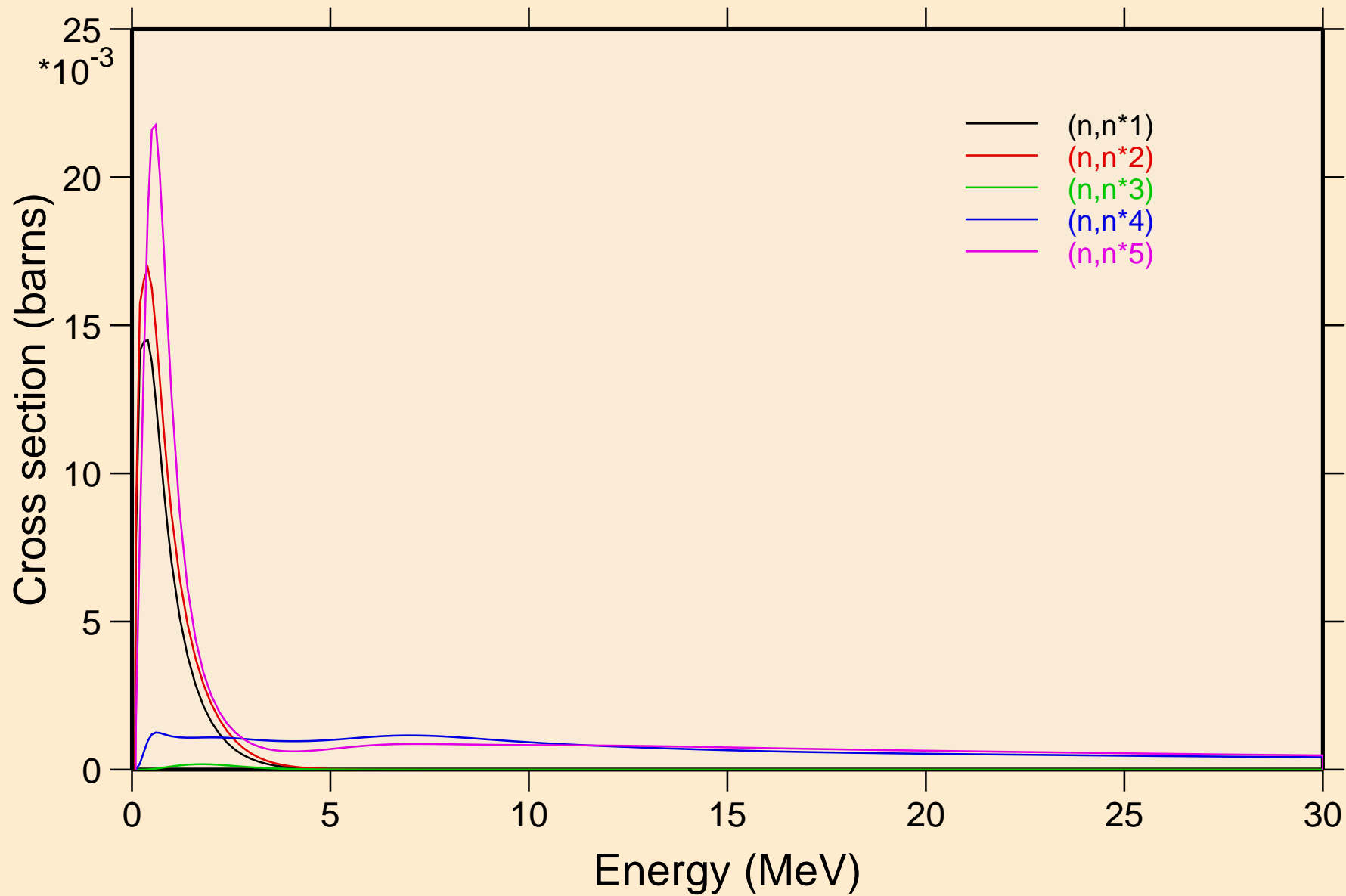

TM158 NEUTRON ACER TENDL-2024 LIBRARY; T=293.6K
Inelastic levels

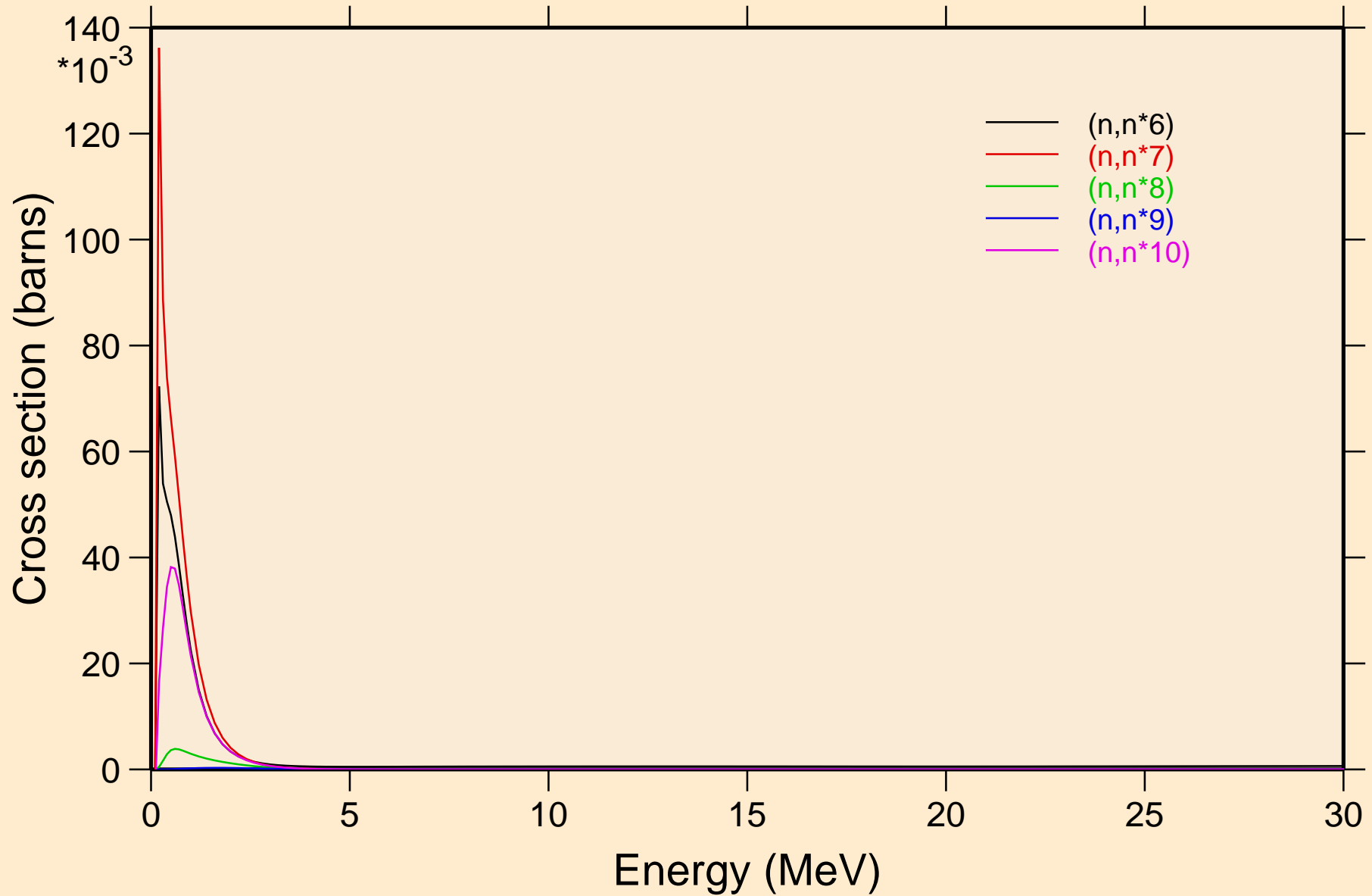

TM158 NEUTRON ACER TENDL-2024 LIBRARY; T=293.6K
Inelastic levels

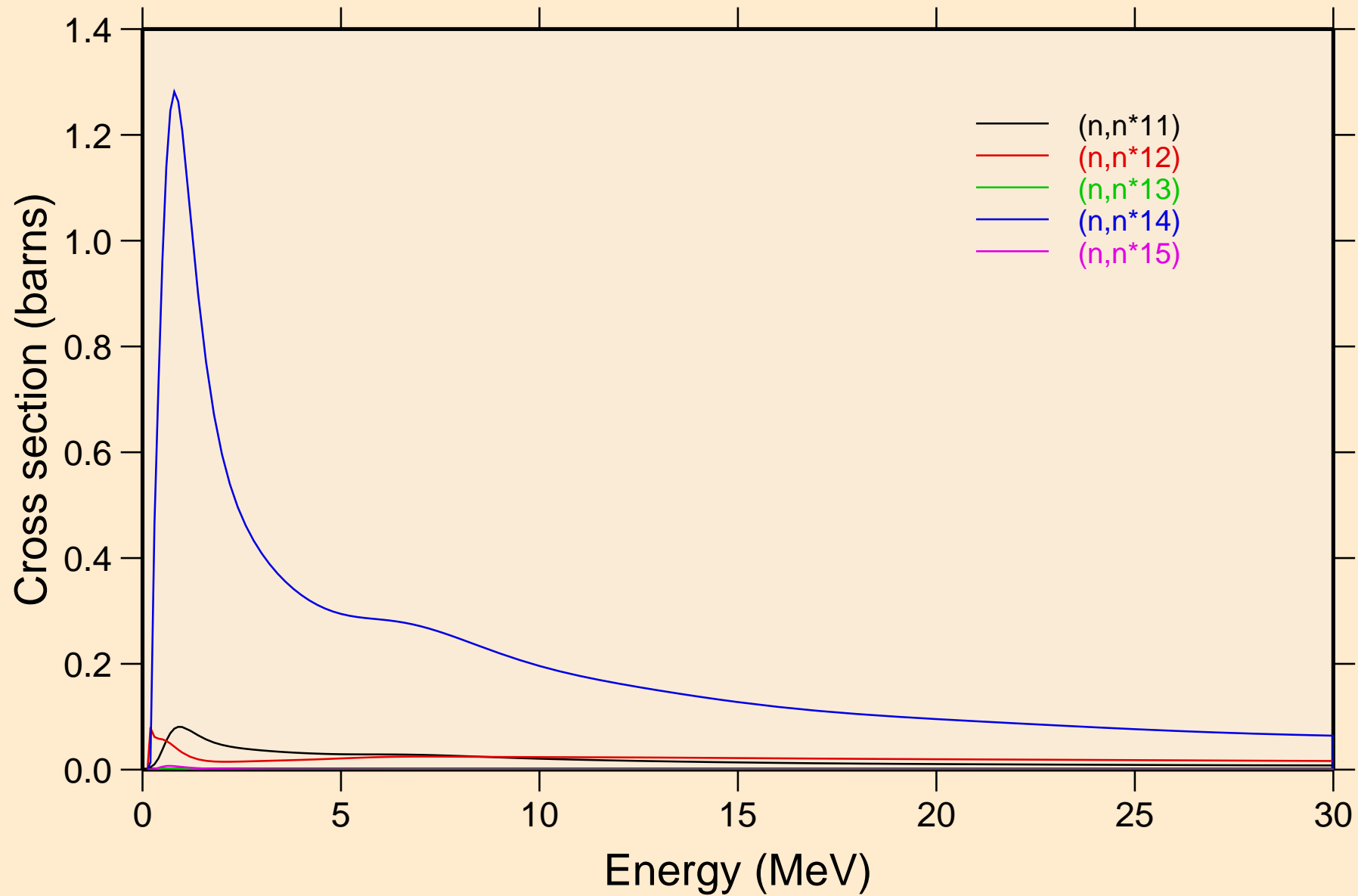

TM158 NEUTRON ACER TENDL-2024 LIBRARY; T=293.6K
Inelastic levels

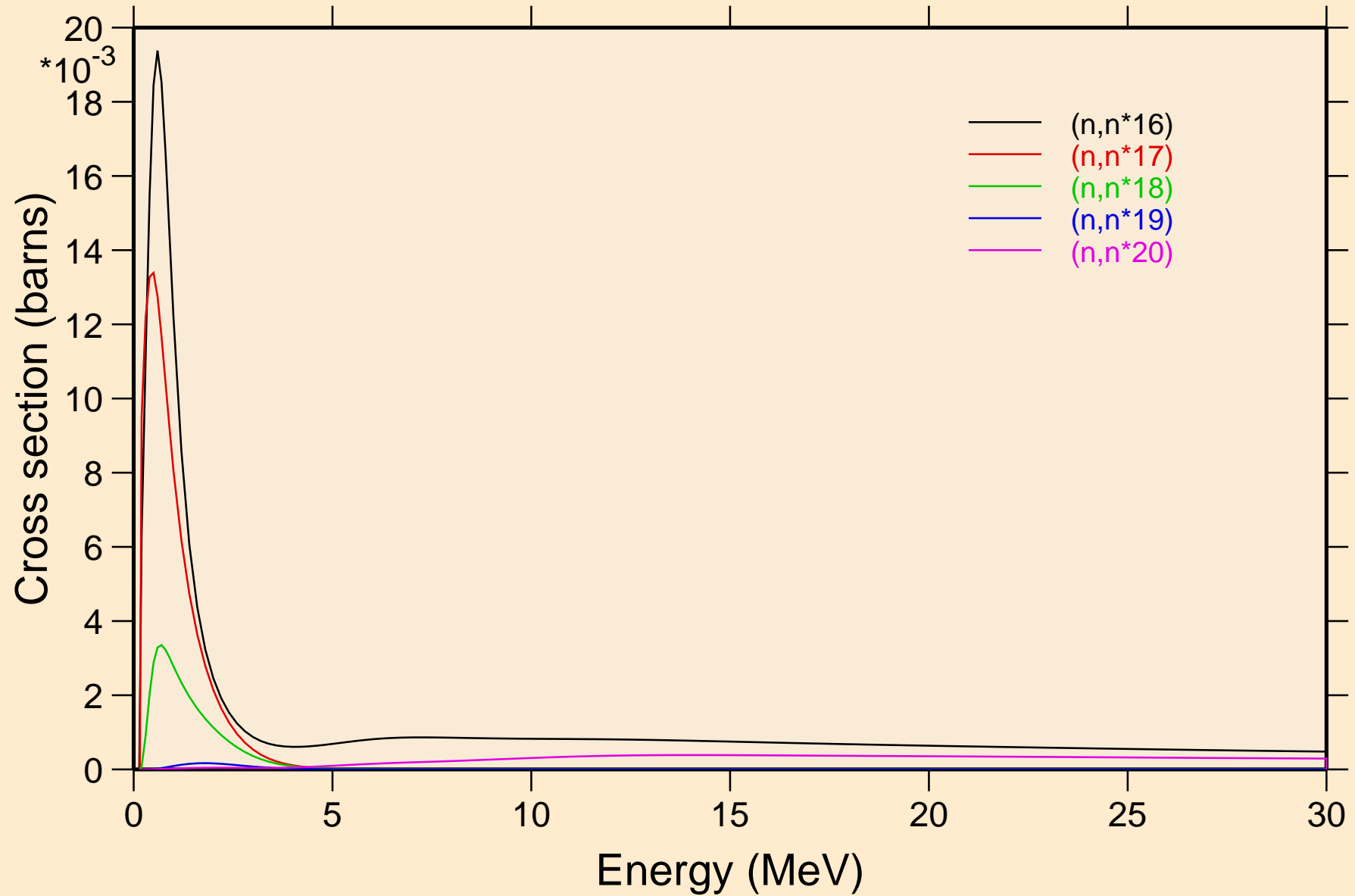

TM158 NEUTRON ACER TENDL-2024 LIBRARY; T=293.6K
Inelastic levels

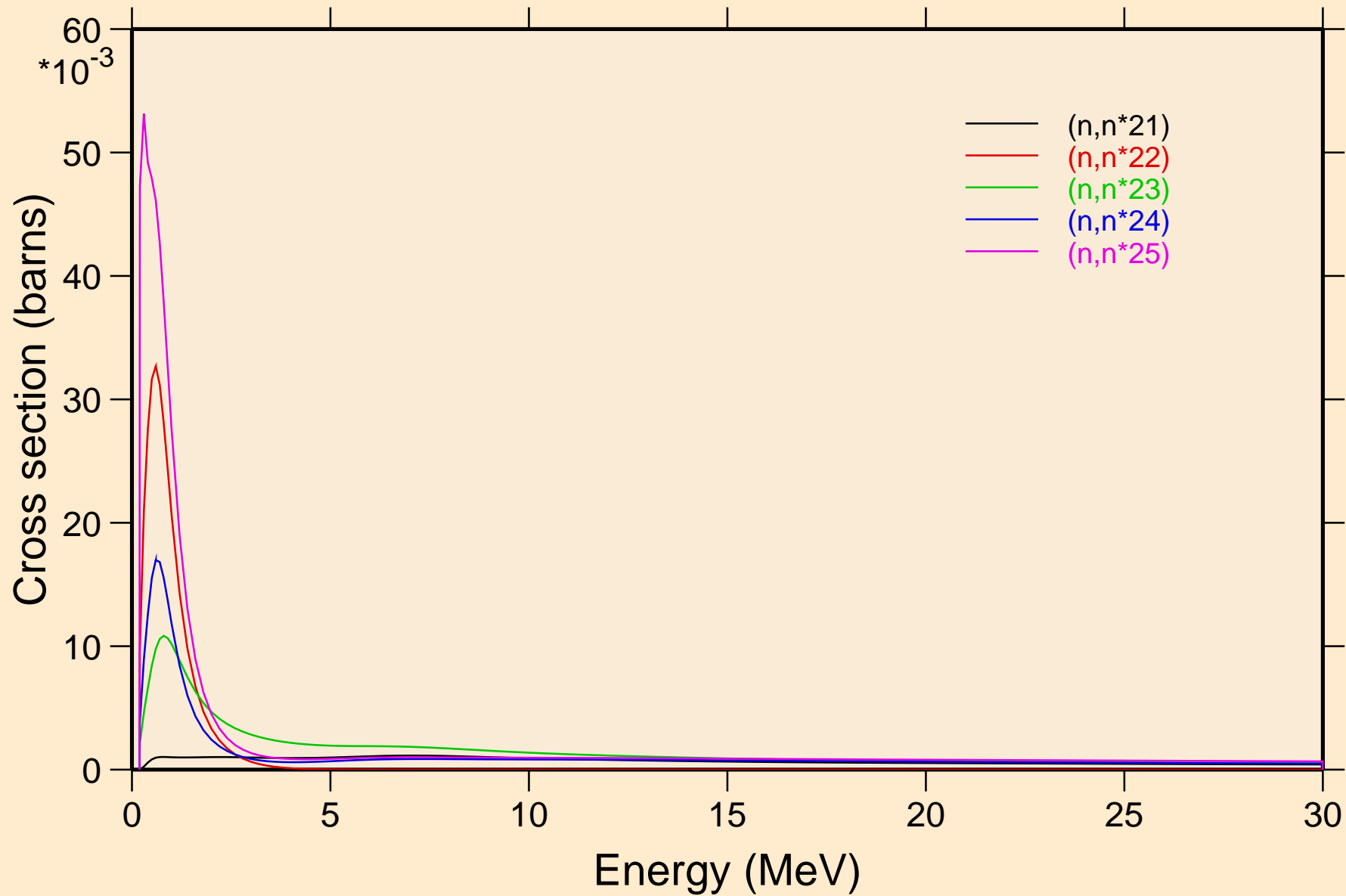

TM158 NEUTRON ACER TENDL-2024 LIBRARY; T=293.6K
Inelastic levels

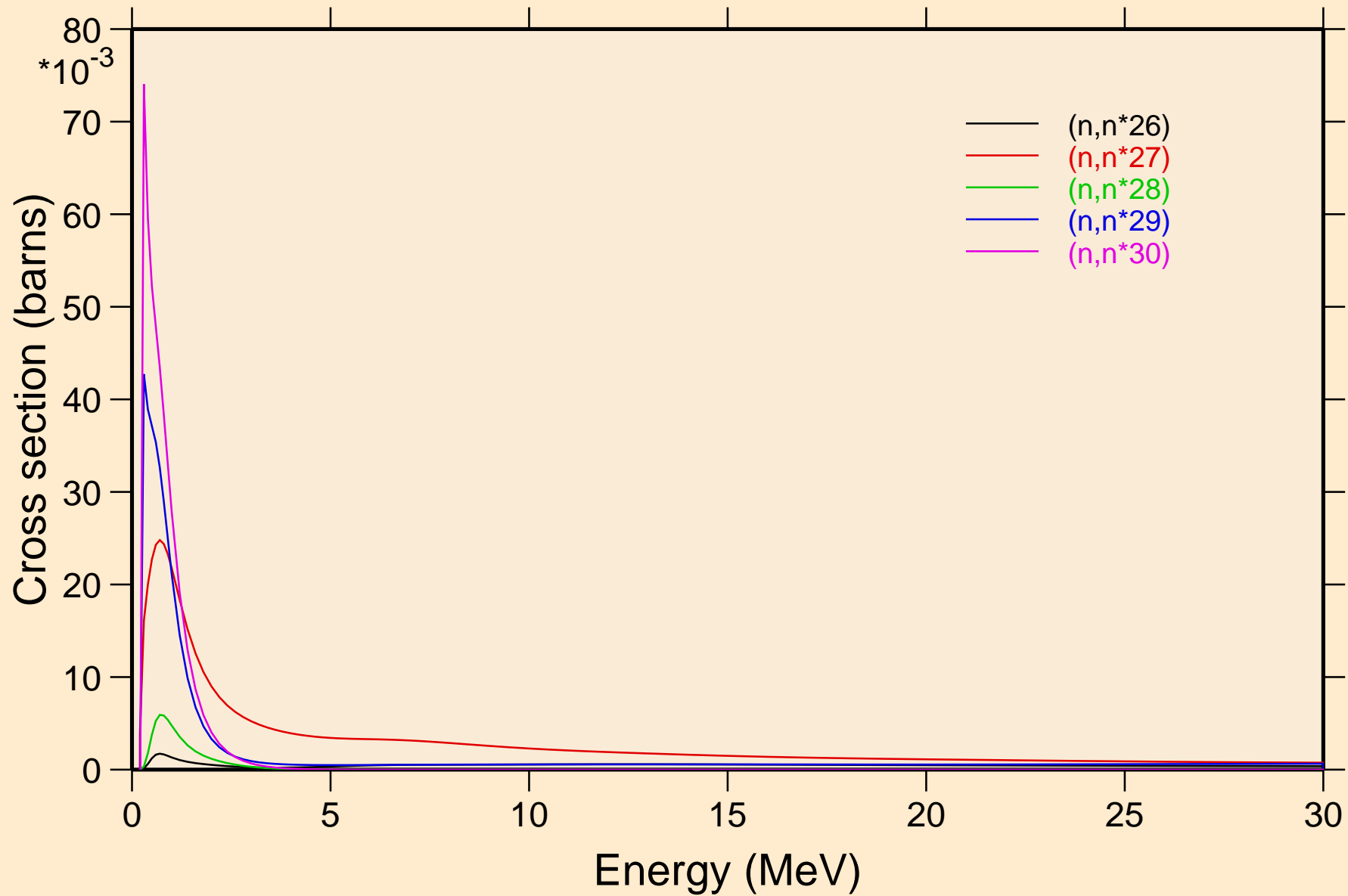

TM158 NEUTRON ACER TENDL-2024 LIBRARY; T=293.6K
Threshold reactions

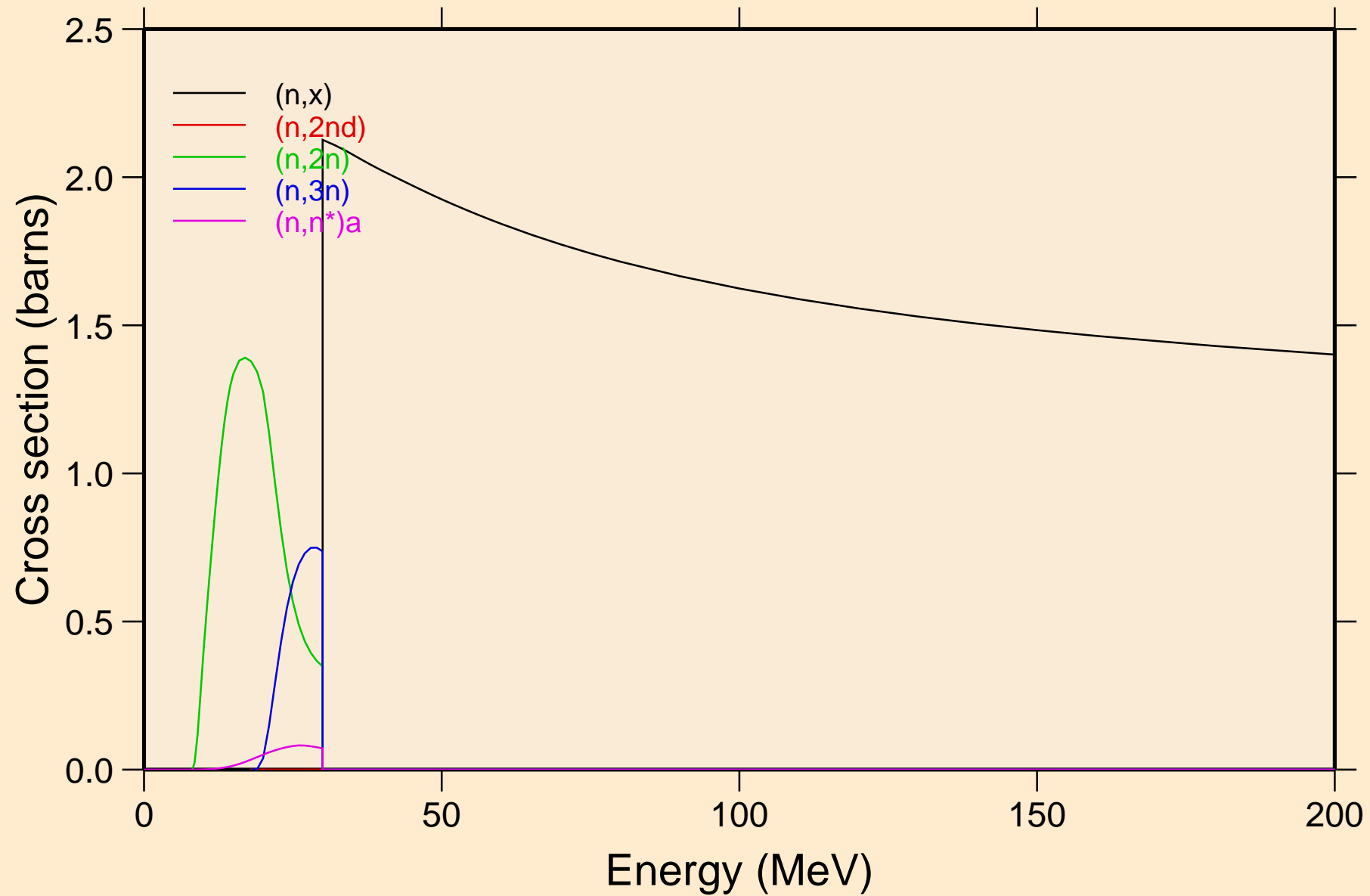

TM158 NEUTRON ACER TENDL-2024 LIBRARY; T=293.6K
Threshold reactions

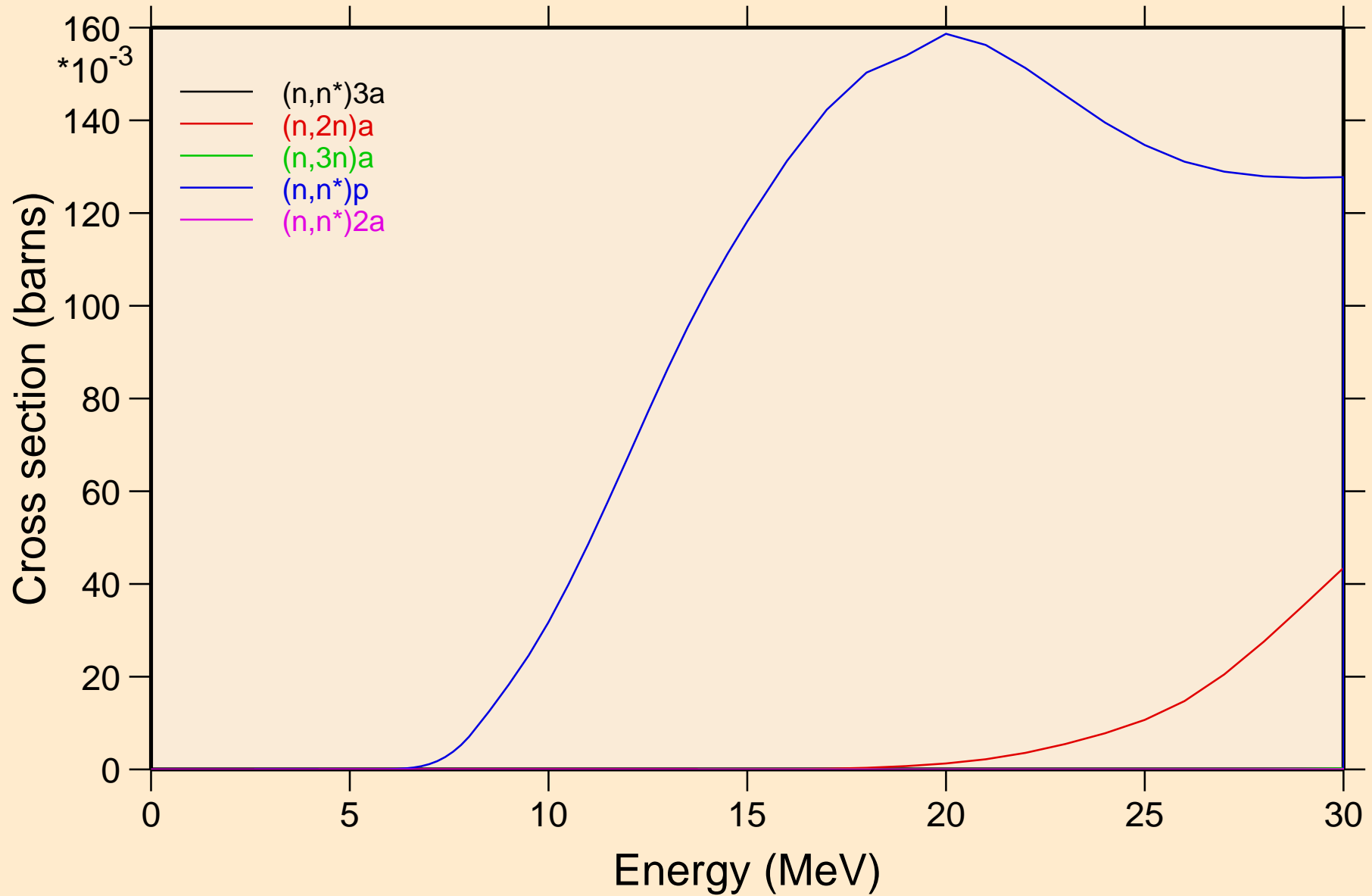

TM158 NEUTRON ACER TENDL-2024 LIBRARY; T=293.6K
Threshold reactions

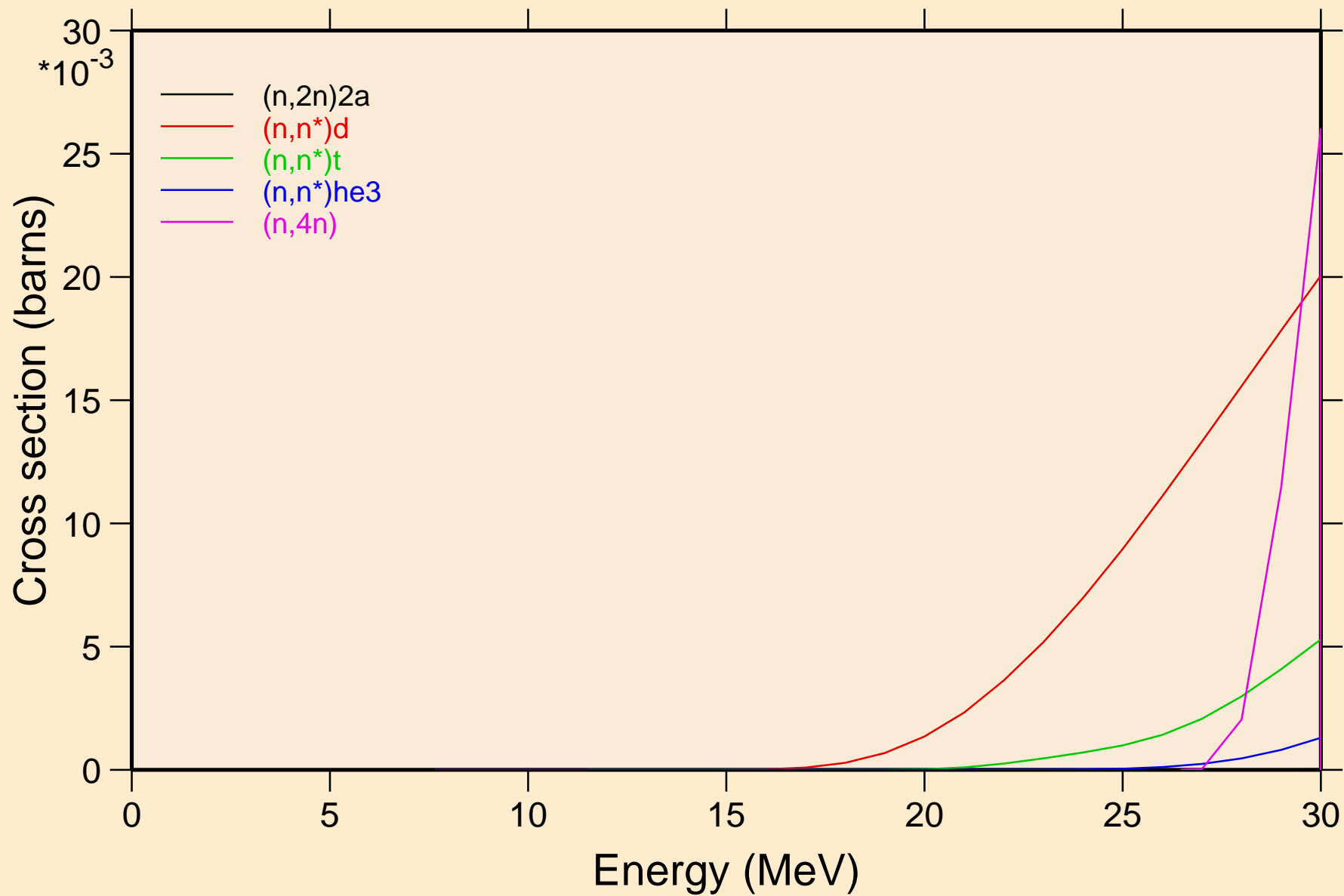

TM158 NEUTRON ACER TENDL-2024 LIBRARY; T=293.6K
Threshold reactions

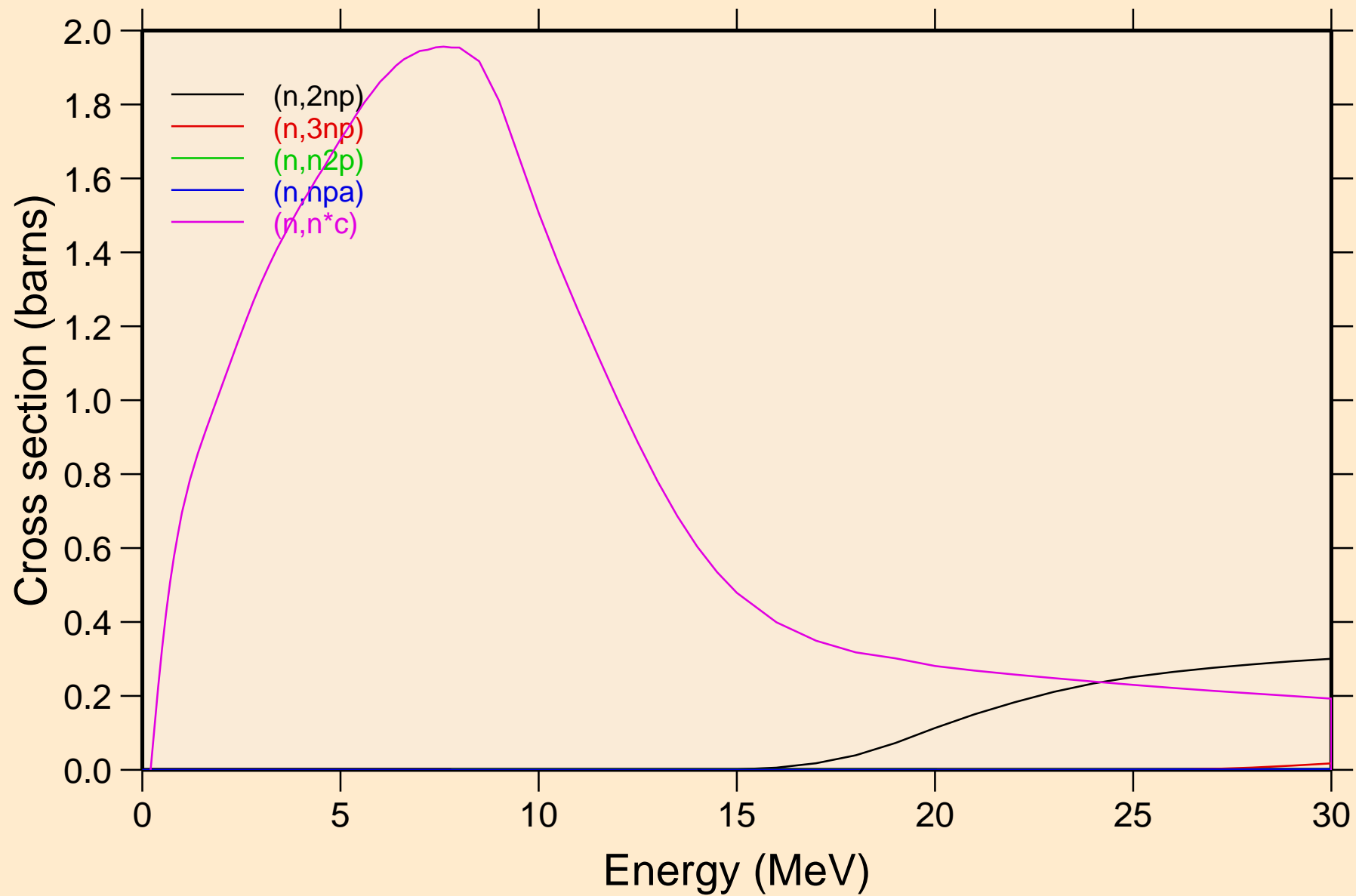

TM158 NEUTRON ACER TENDL-2024 LIBRARY; T=293.6K
Threshold reactions

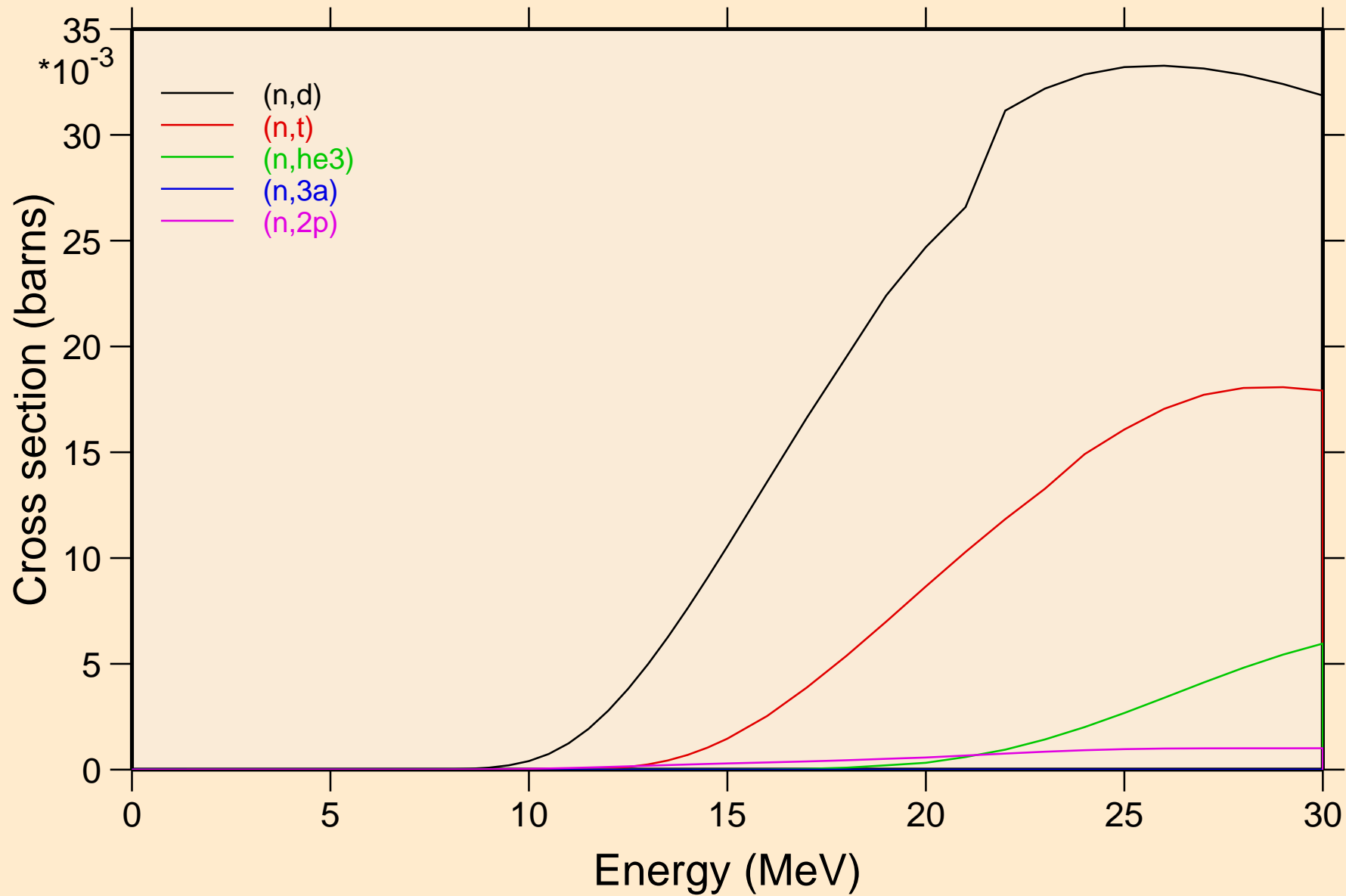

TM158 NEUTRON ACER TENDL-2024 LIBRARY; T=293.6K
Threshold reactions

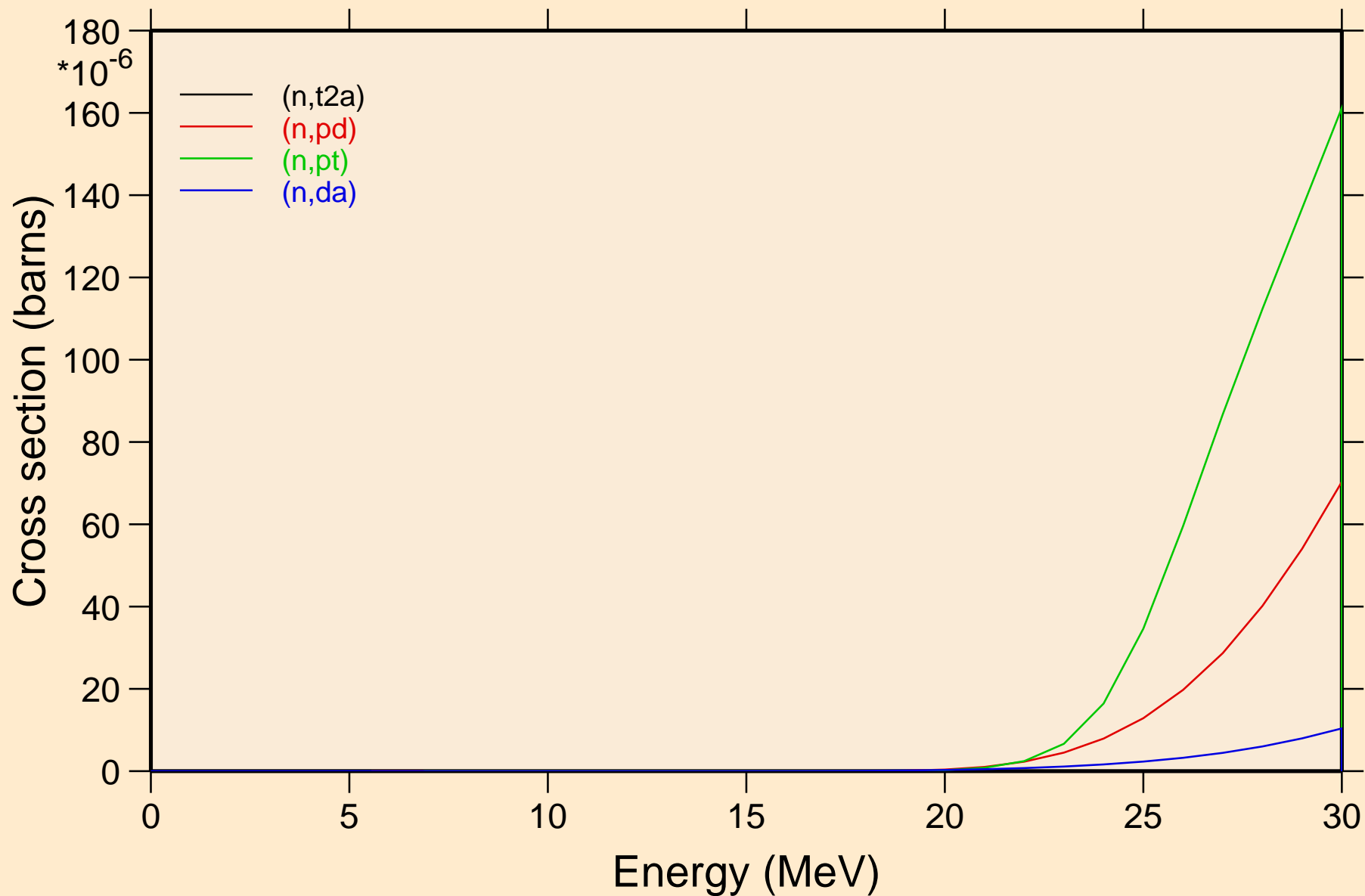

TM158 NEUTRON ACER TENDL-2024 LIBRARY; T=293.6K
Threshold reactions

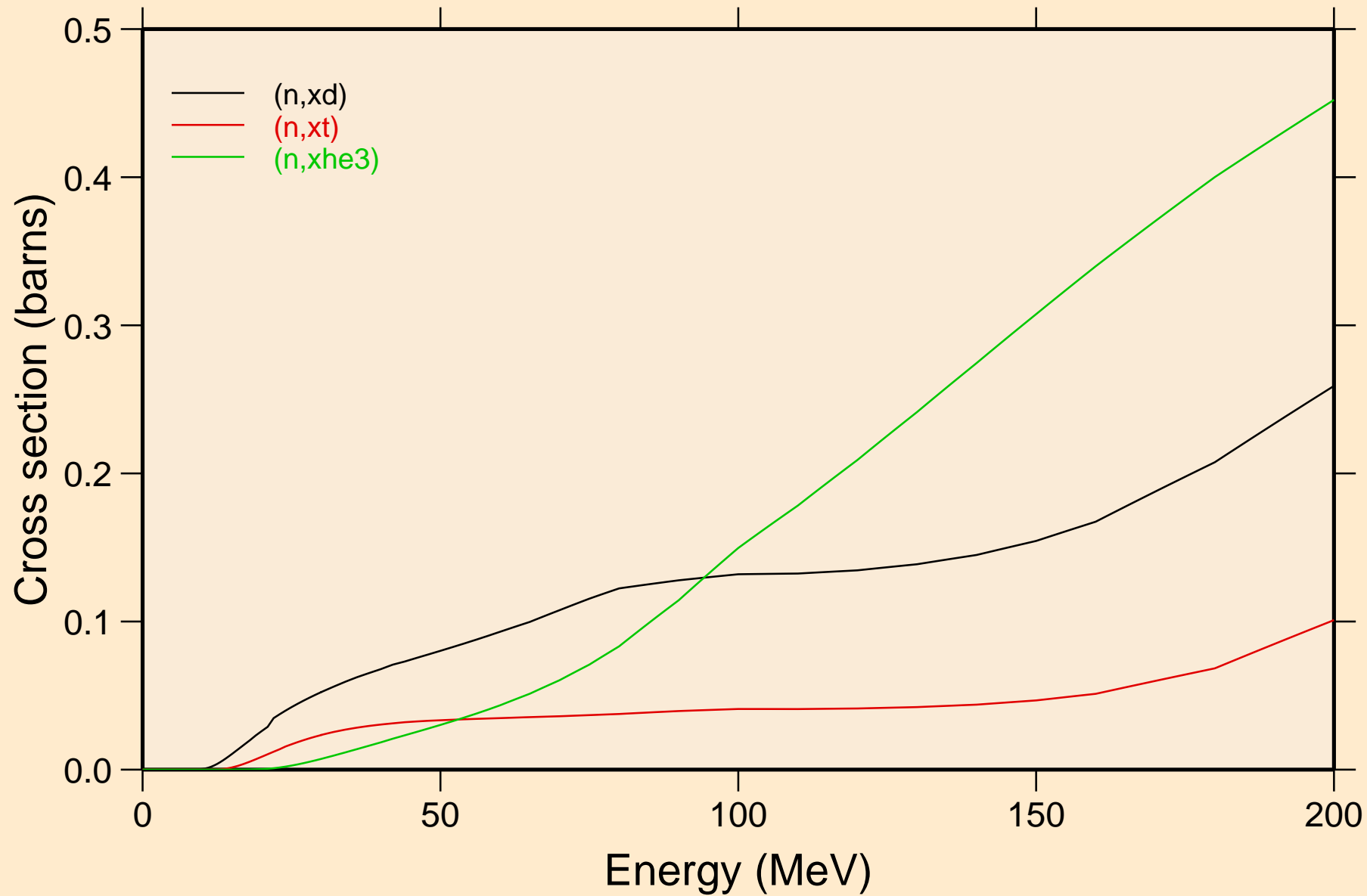

TM158 NEUTRON ACER TENDL-2024 LIBRARY; T=293.6K
angular distribution for elastic

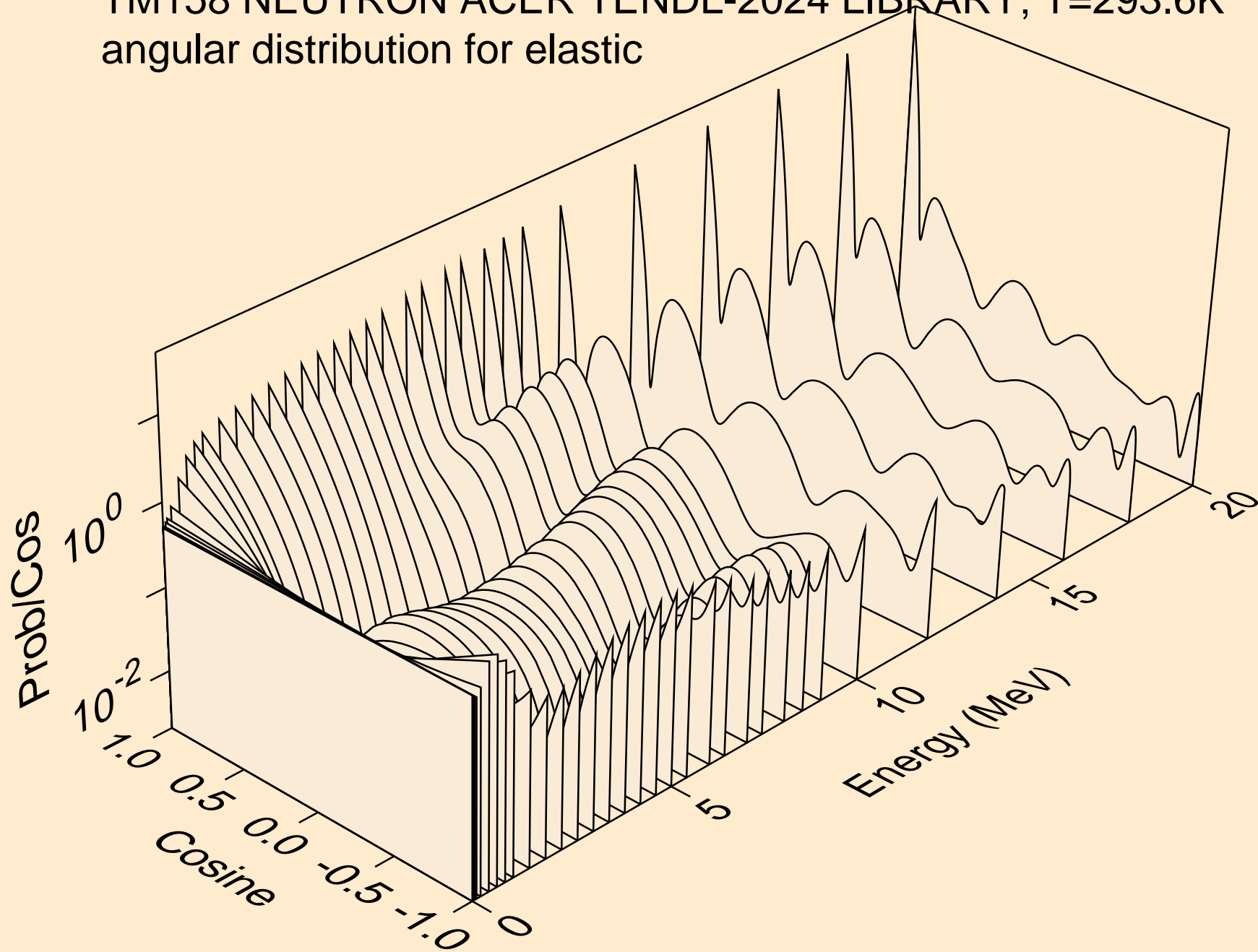

TM158 NEUTRON ACER TENDL-2024 LIBRARY; T=293.6K
angular distribution for elastic

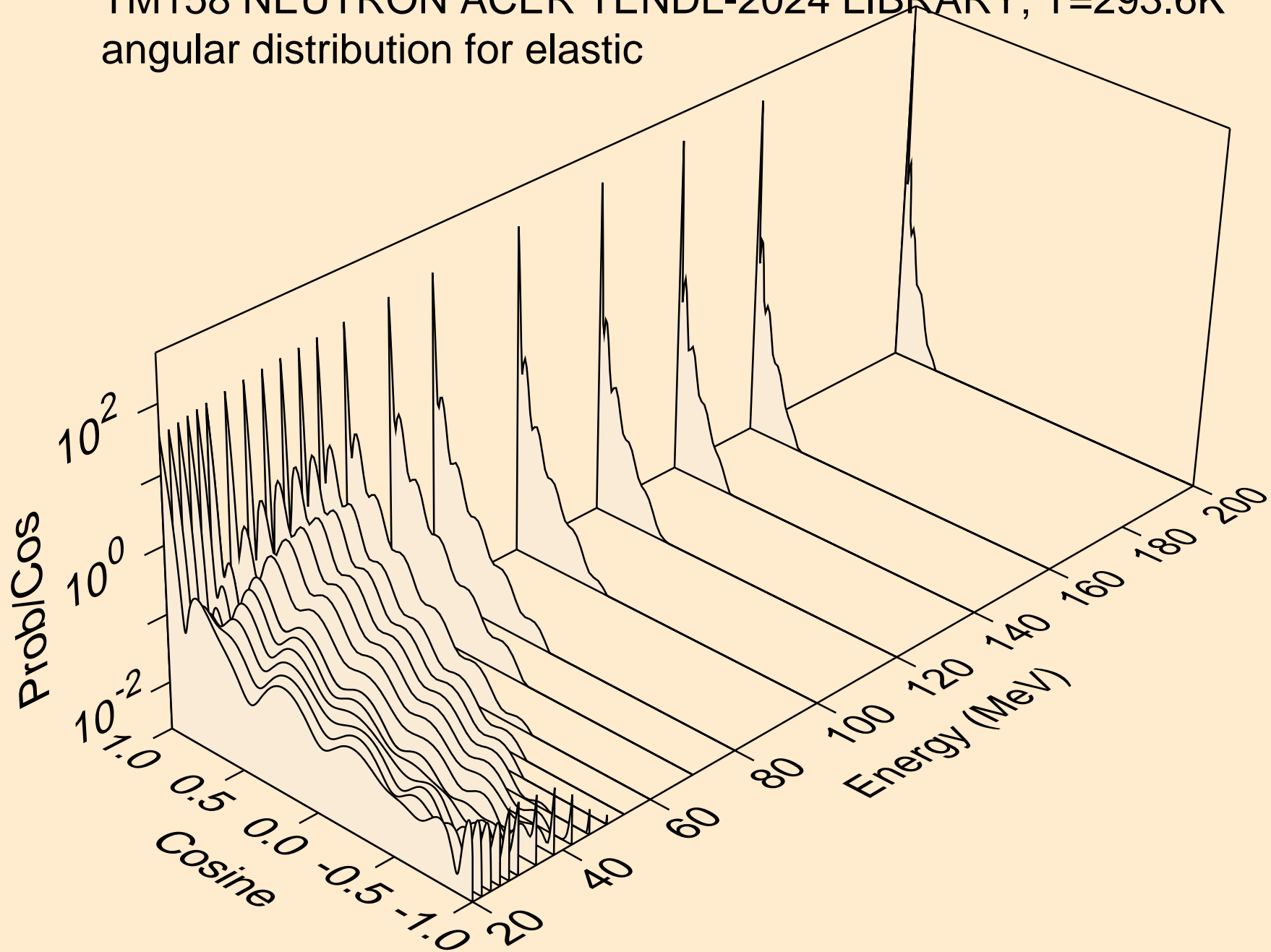

TM158 NEUTRON ACER TENDL-2024 LIBRARY; T=293.6K
angular distribution for (n,n*1)

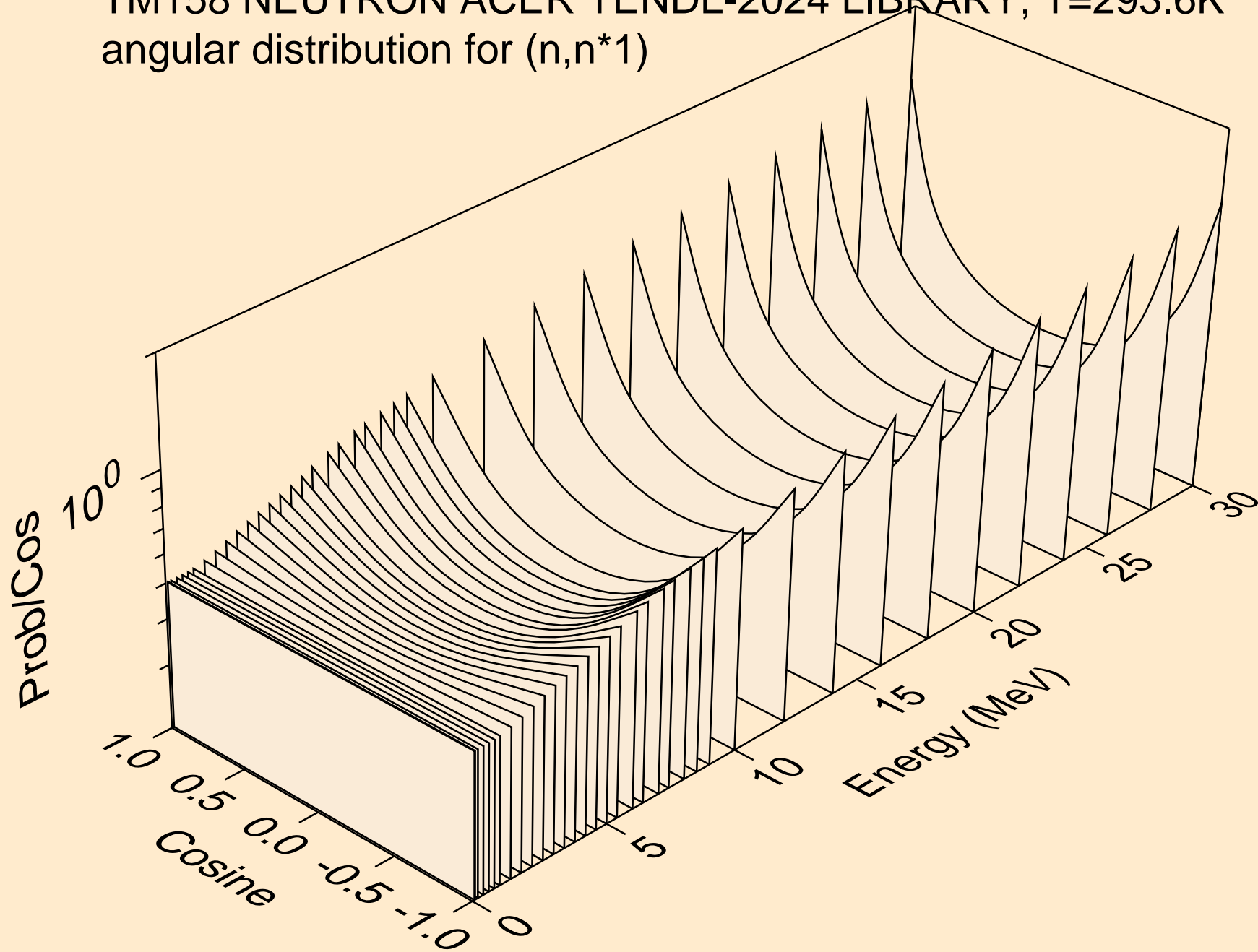

TM158 NEUTRON ACER TENDL-2024 LIBRARY; T=293.6K
angular distribution for (n,n*2)

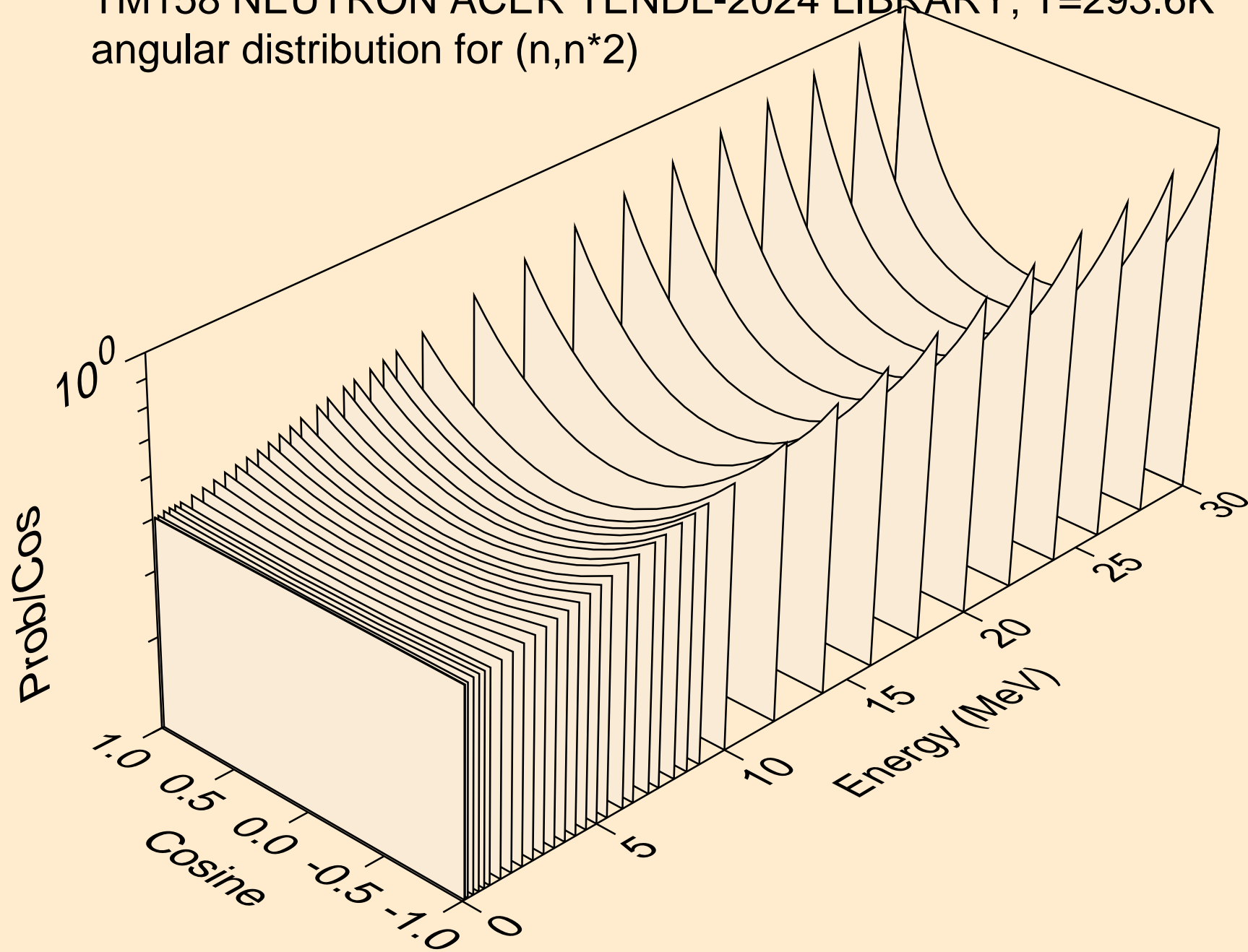

TM158 NEUTRON ACER TENDL-2024 LIBRARY; T=293.6K
angular distribution for (n,n*3)

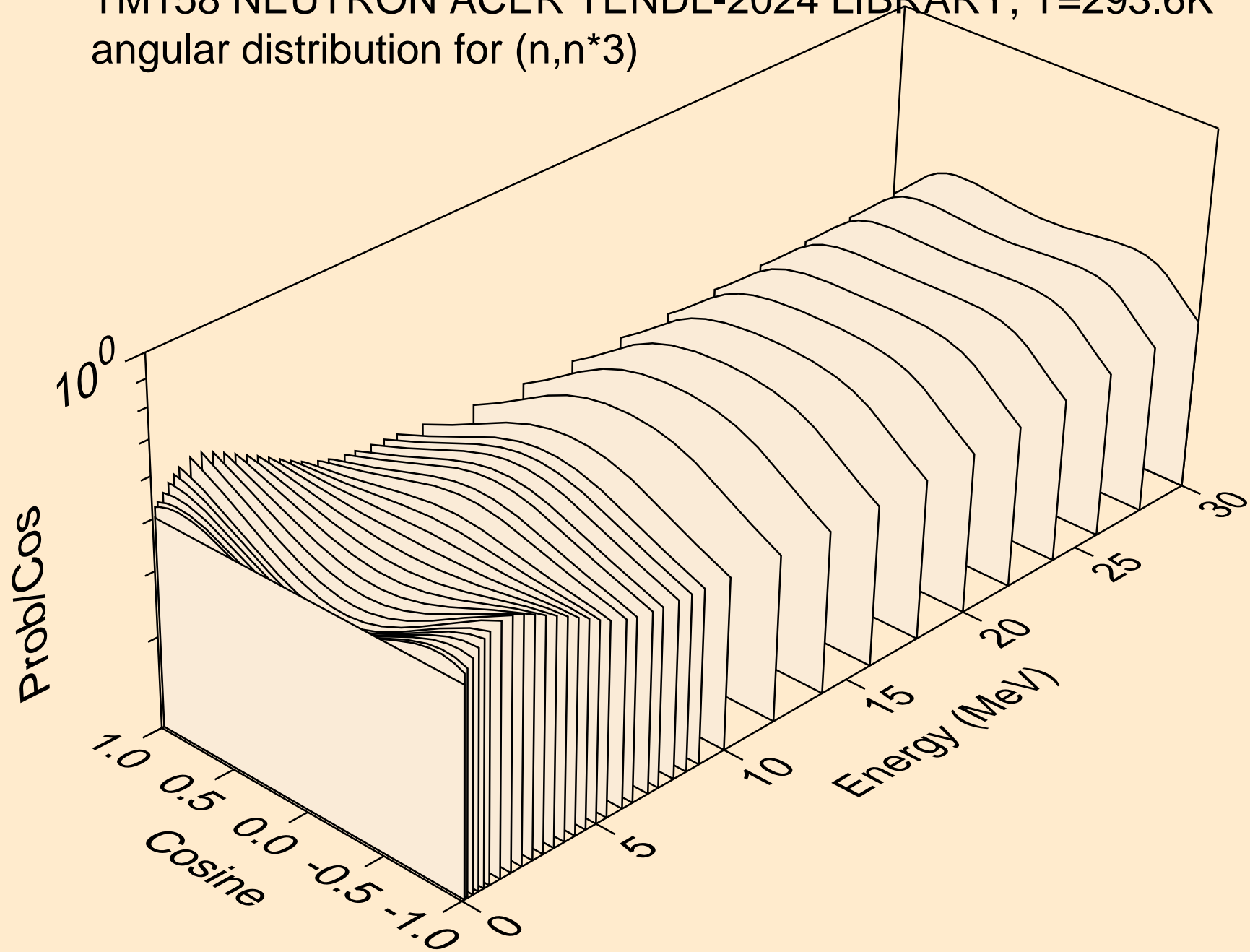

TM158 NEUTRON ACER TENDL-2024 LIBRARY; T=293.6K
angular distribution for (n,n*4)

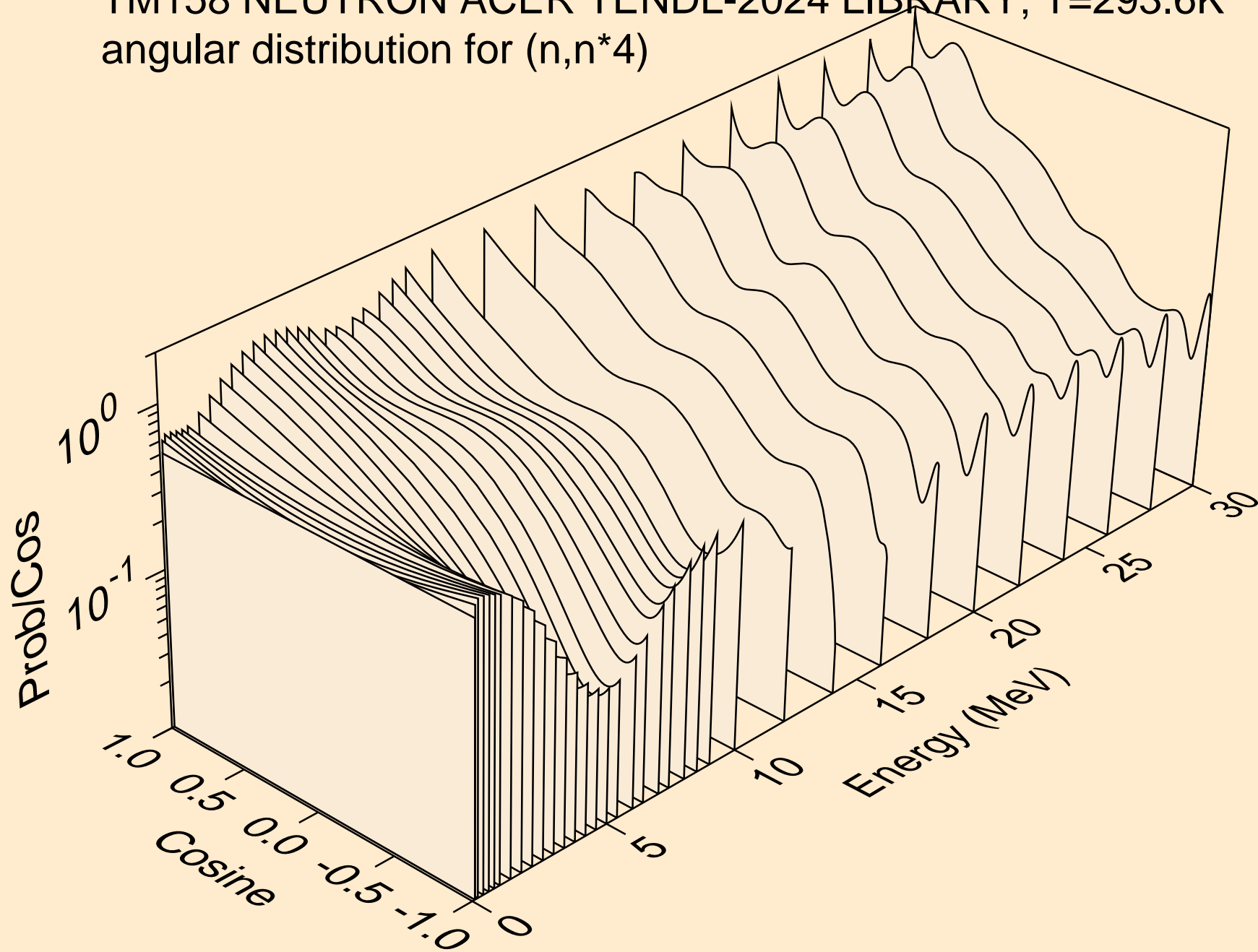

TM158 NEUTRON ACER TENDL-2024 LIBRARY; T=293.6K
angular distribution for (n,n*5)

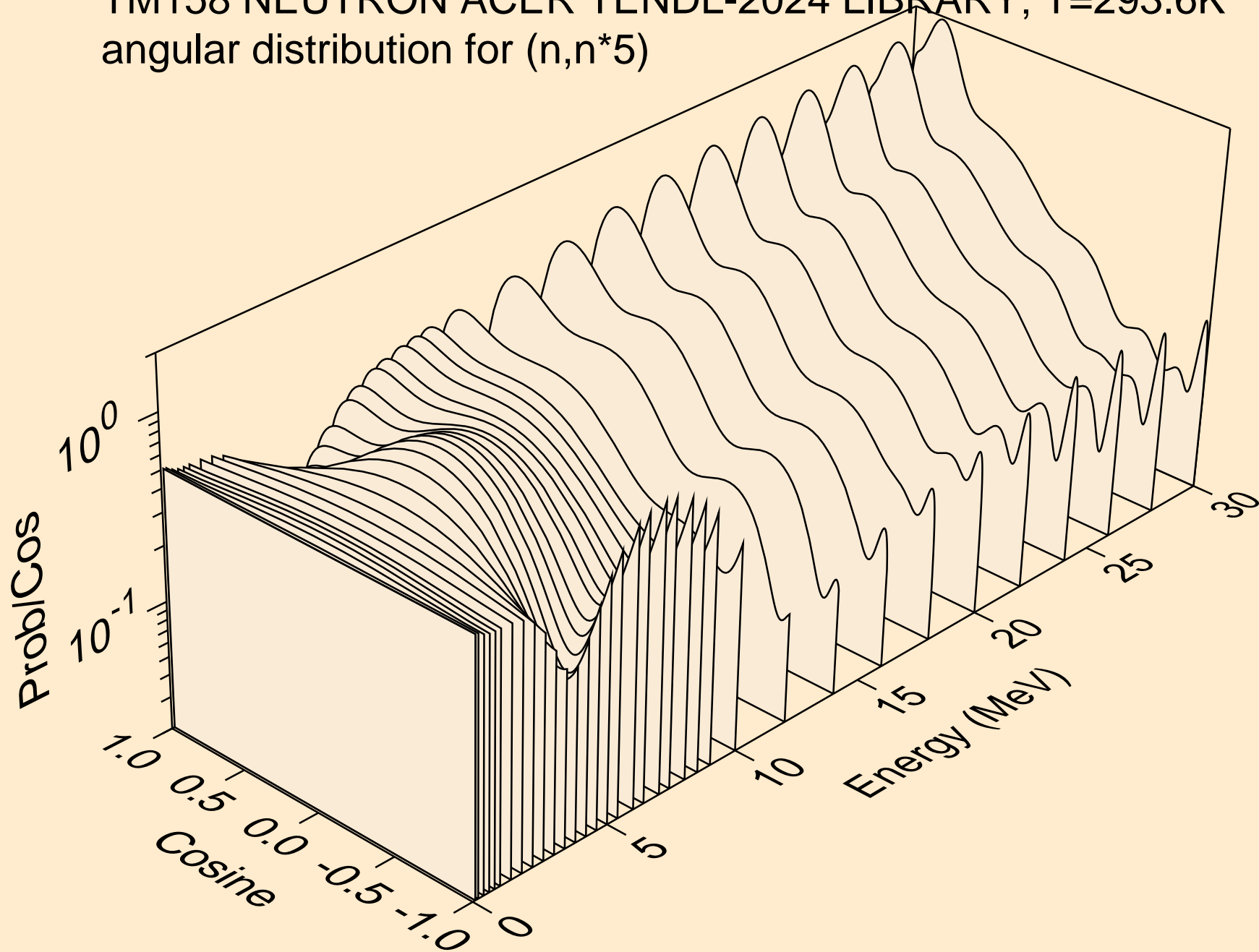

TM158 NEUTRON ACER TENDL-2024 LIBRARY; T=293.6K
angular distribution for (n,n*6)

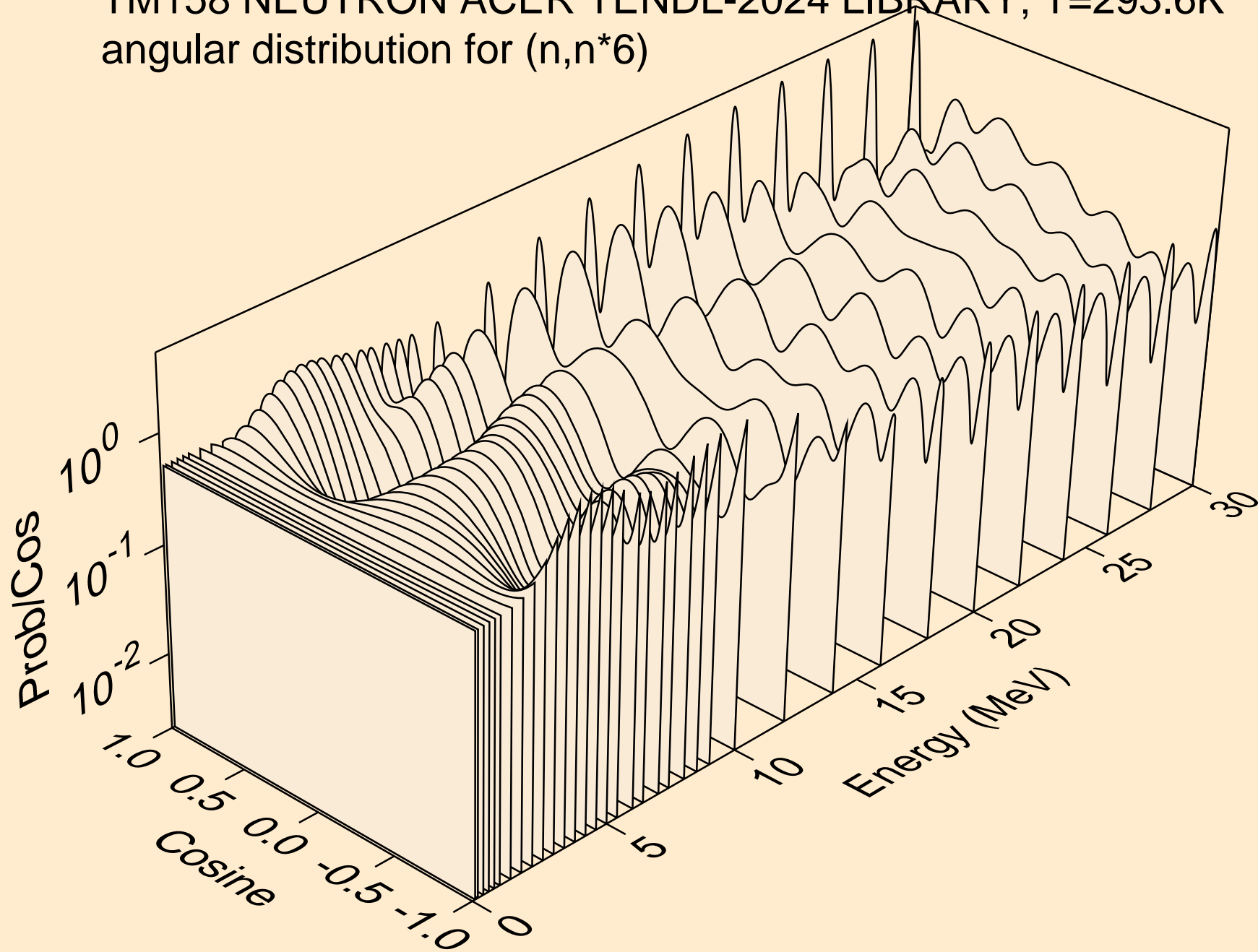

TM158 NEUTRON ACER TENDL-2024 LIBRARY; T=293.6K
angular distribution for (n,n*7)

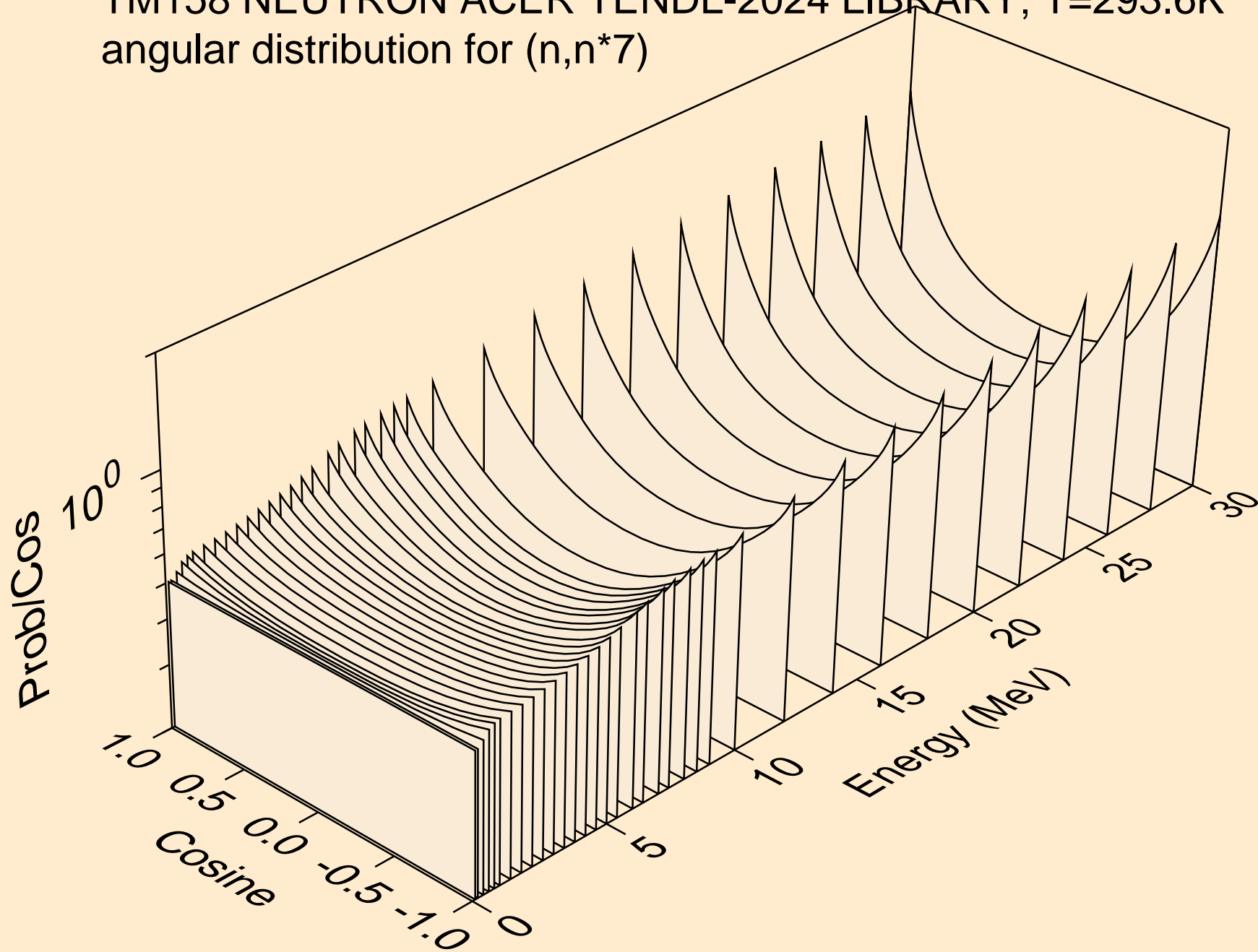

TM158 NEUTRON ACER TENDL-2024 LIBRARY; T=293.6K
angular distribution for (n,n*8)

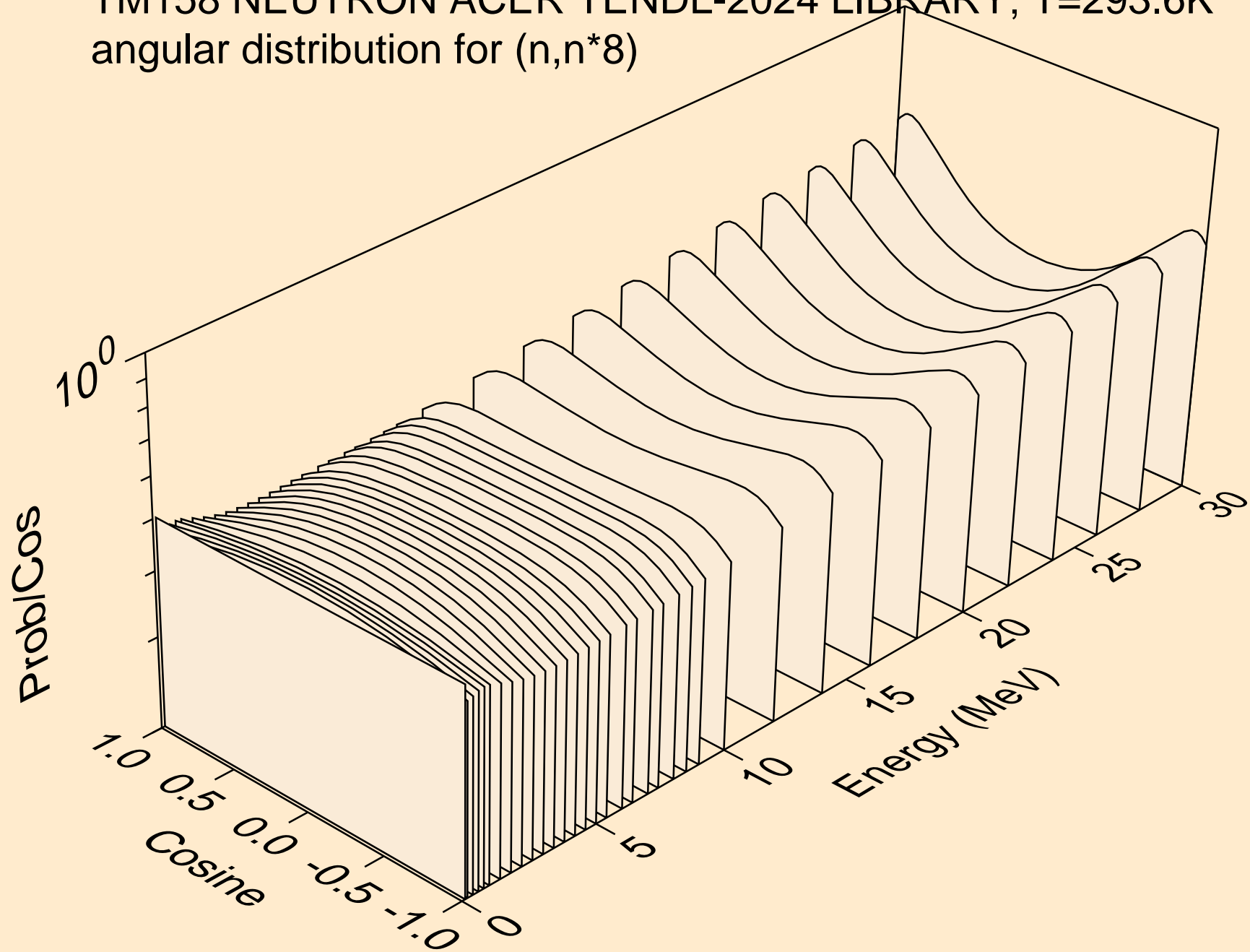

TM158 NEUTRON ACER TENDL-2024 LIBRARY; T=293.6K
angular distribution for (n,n*9)

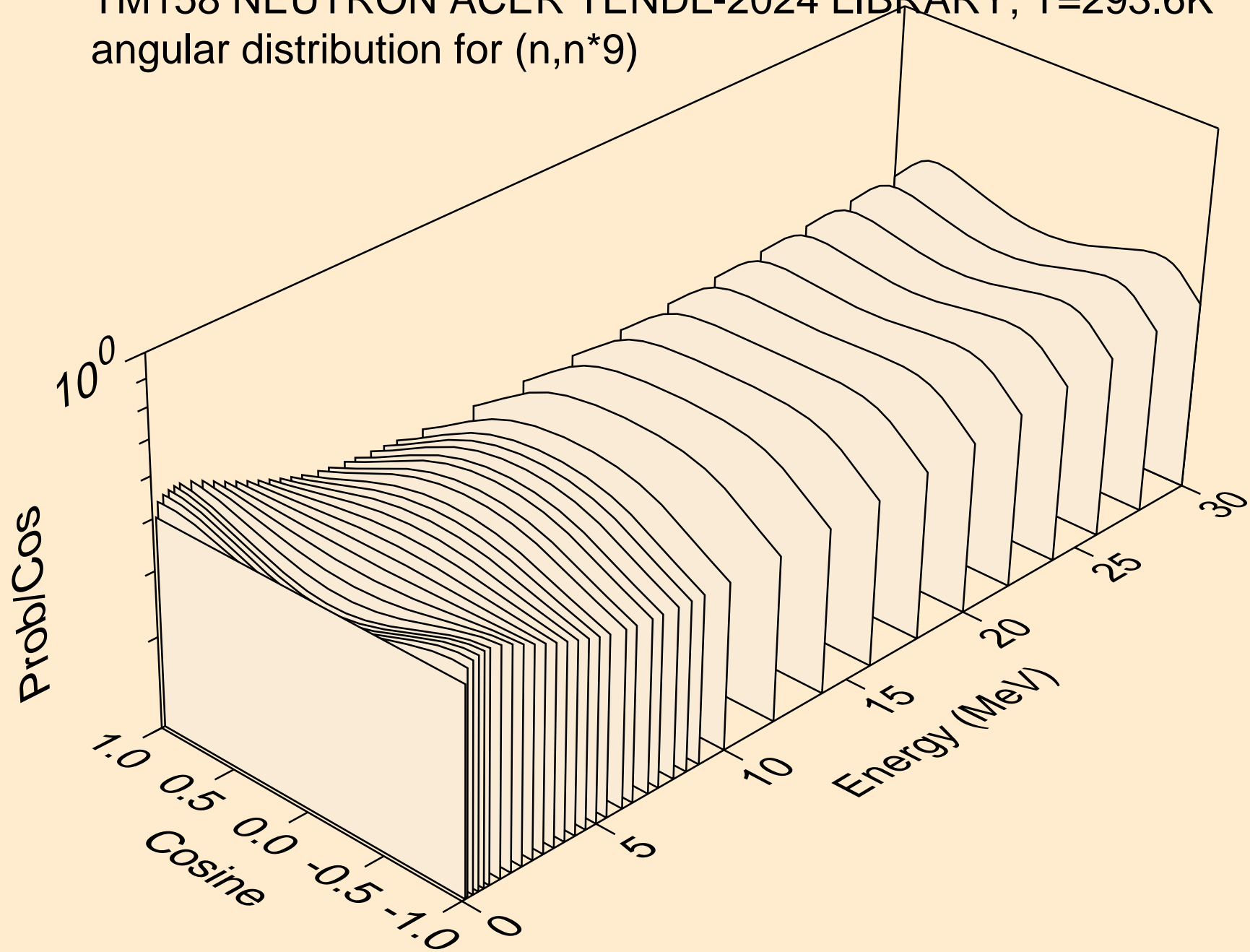

TM158 NEUTRON ACER TENDL-2024 LIBRARY; T=293.6K
angular distribution for (n,n*10)

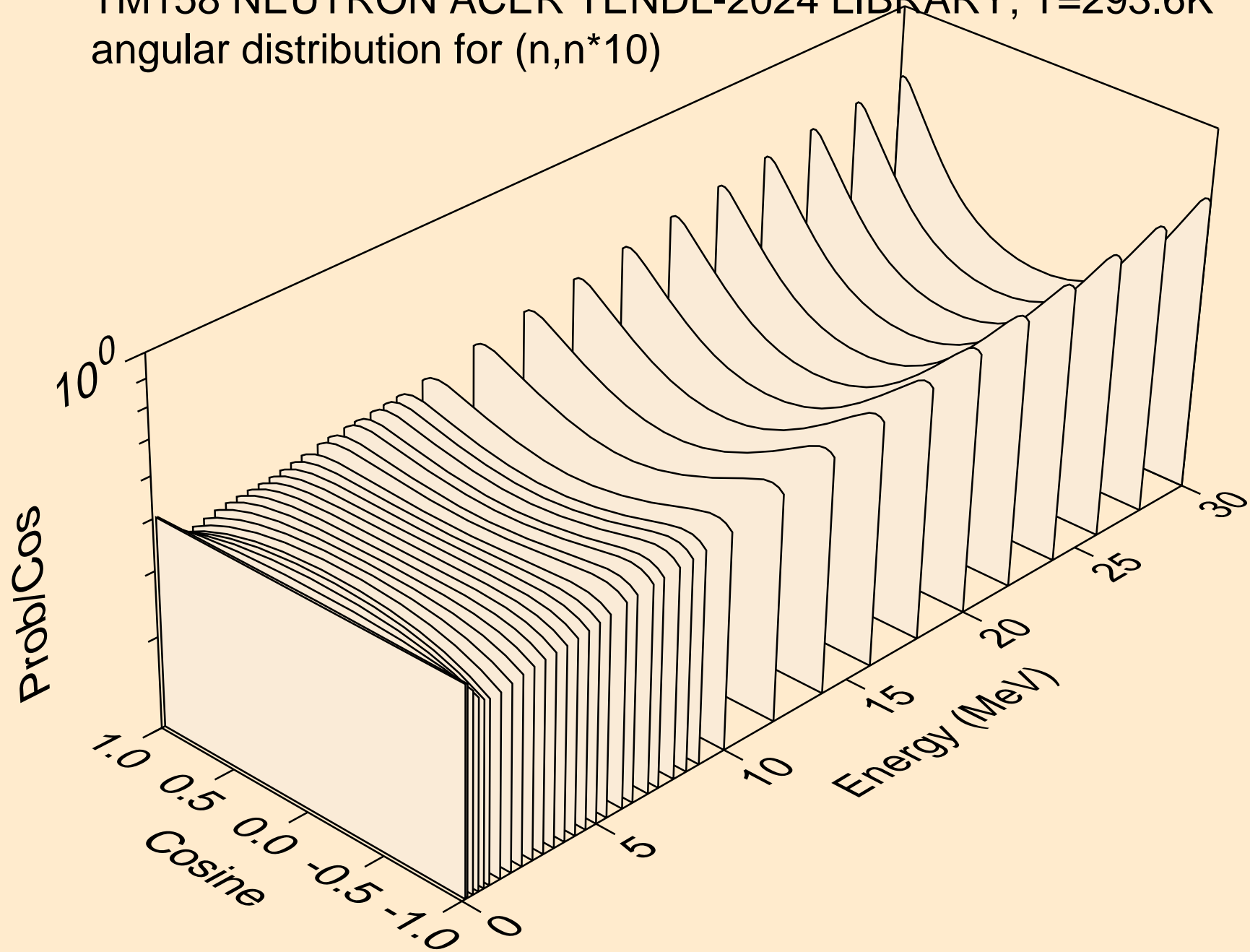

TM158 NEUTRON ACER TENDL-2024 LIBRARY; T=293.6K
angular distribution for (n,n*11)

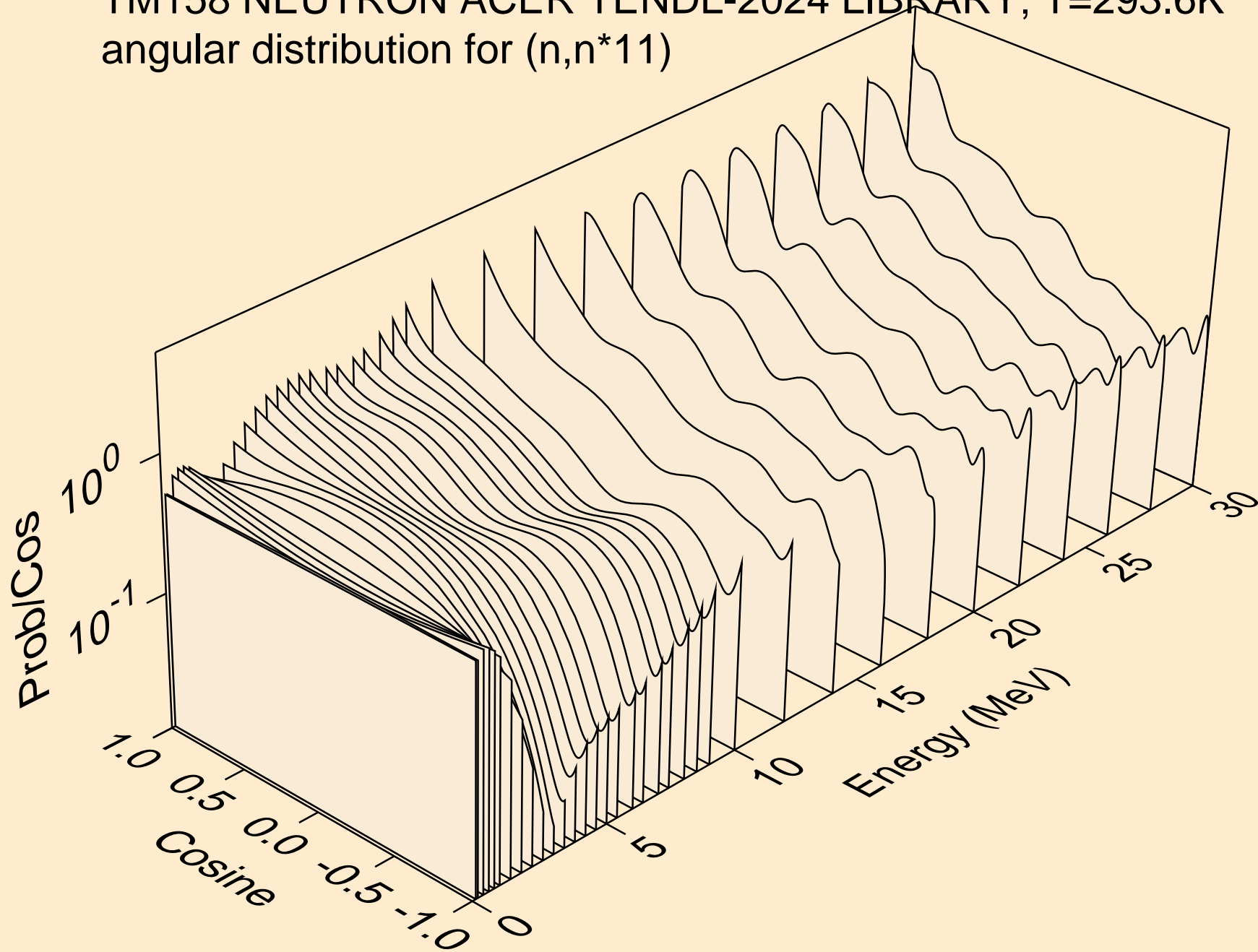

TM158 NEUTRON ACER TENDL-2024 LIBRARY; T=293.6K
angular distribution for (n,n*12)

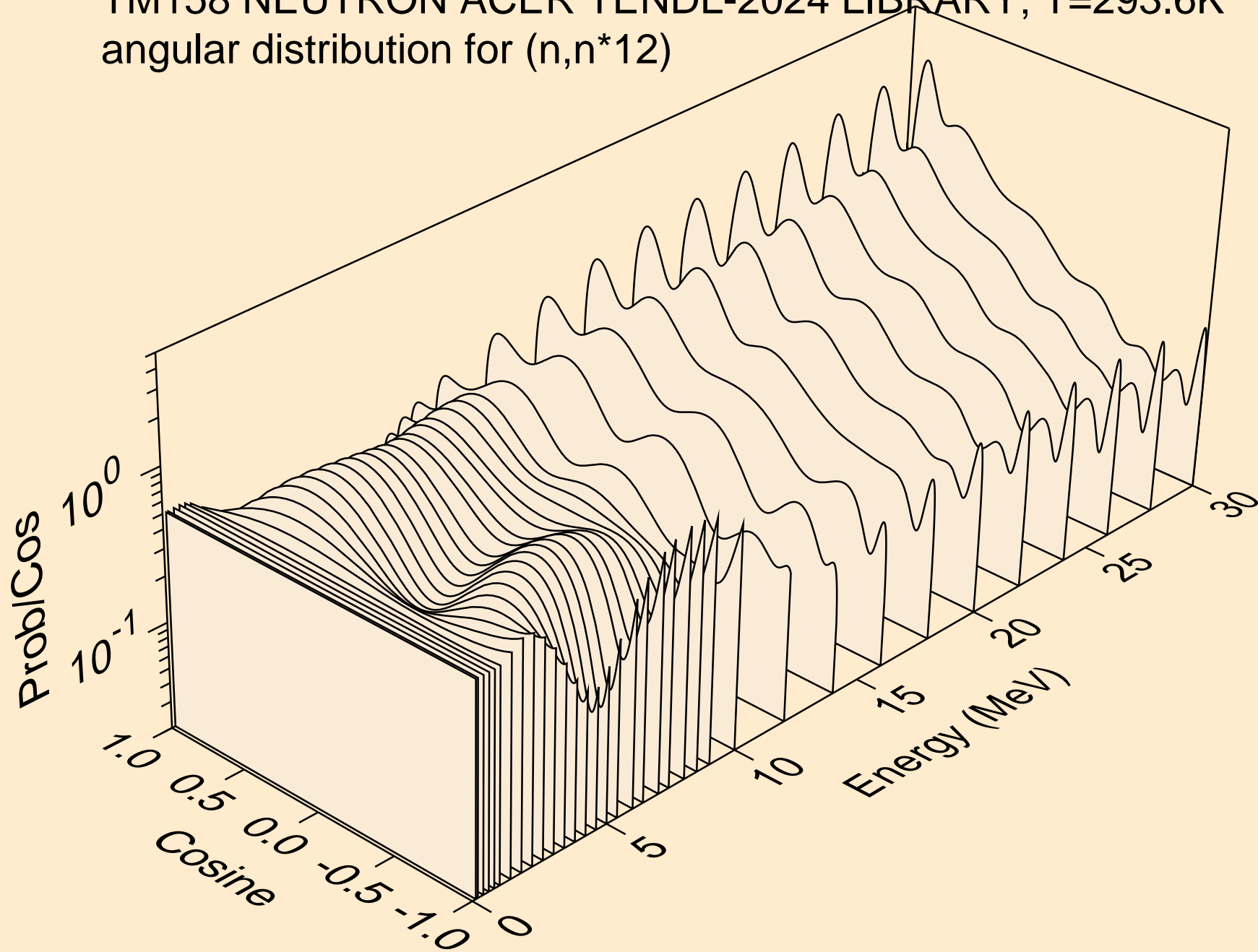

TM158 NEUTRON ACER TENDL-2024 LIBRARY; T=293.6K
angular distribution for (n,n*13)

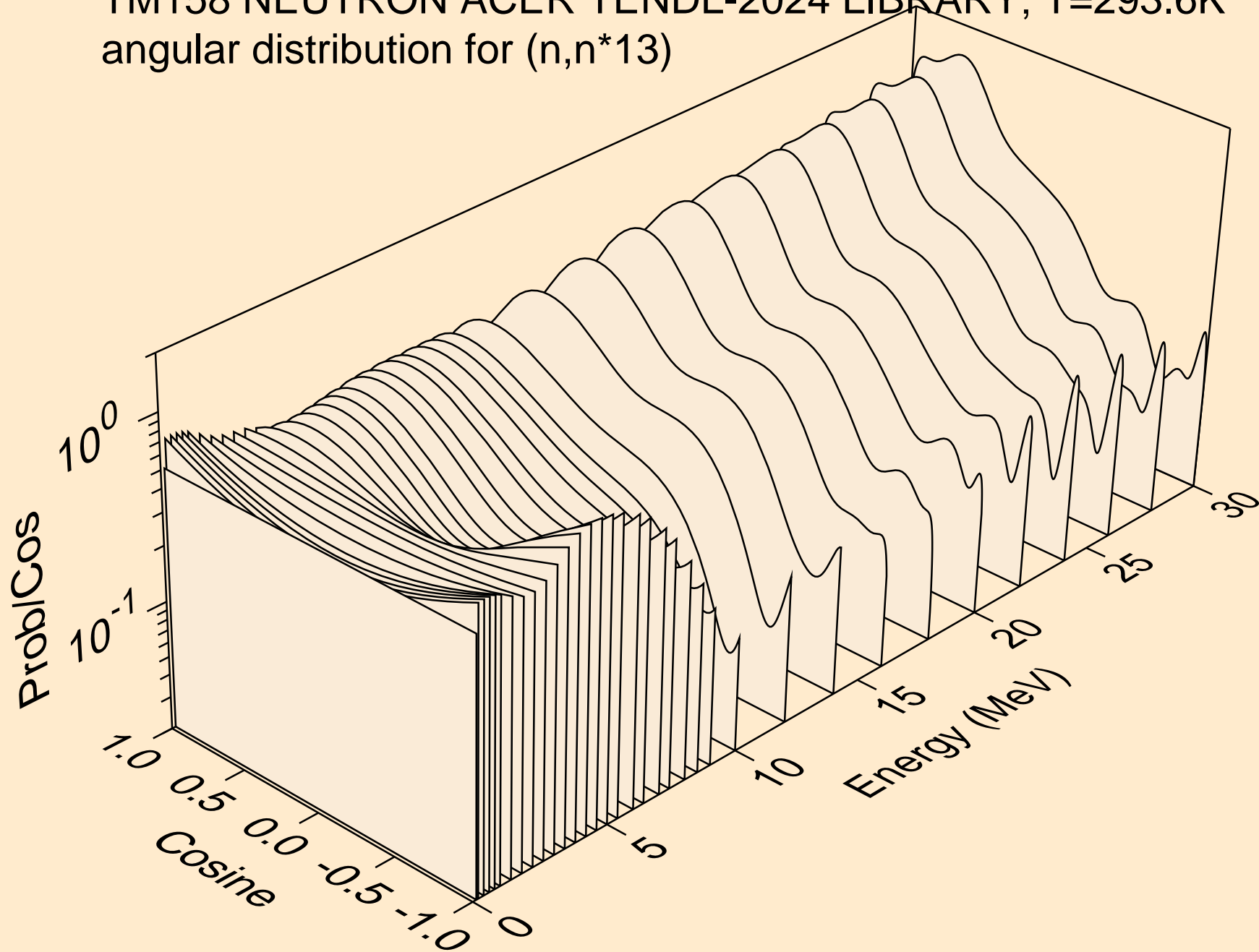

TM158 NEUTRON ACER TENDL-2024 LIBRARY; T=293.6K
angular distribution for (n,n*14)

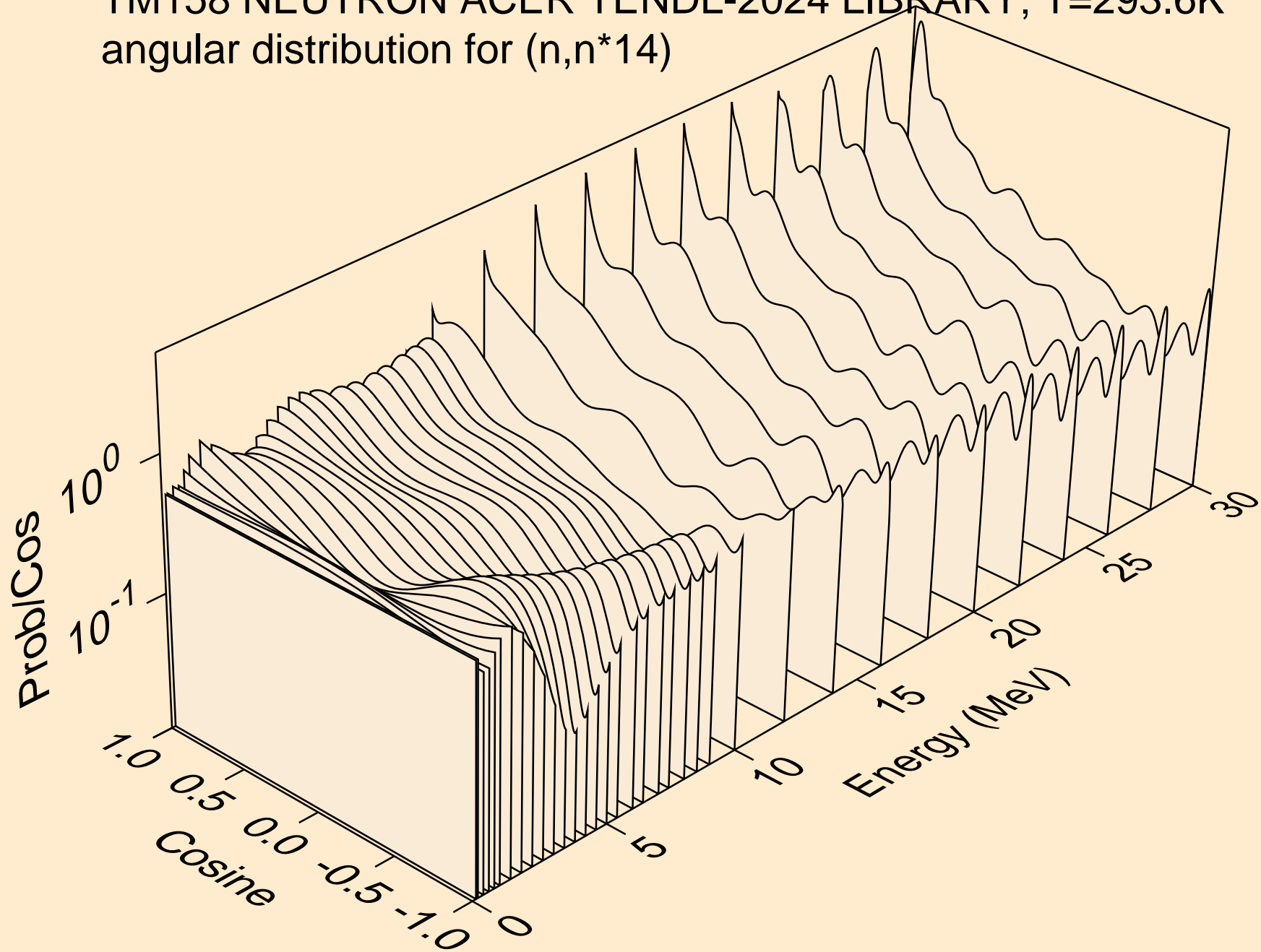

TM158 NEUTRON ACER TENDL-2024 LIBRARY; T=293.6K
angular distribution for (n,n*15)

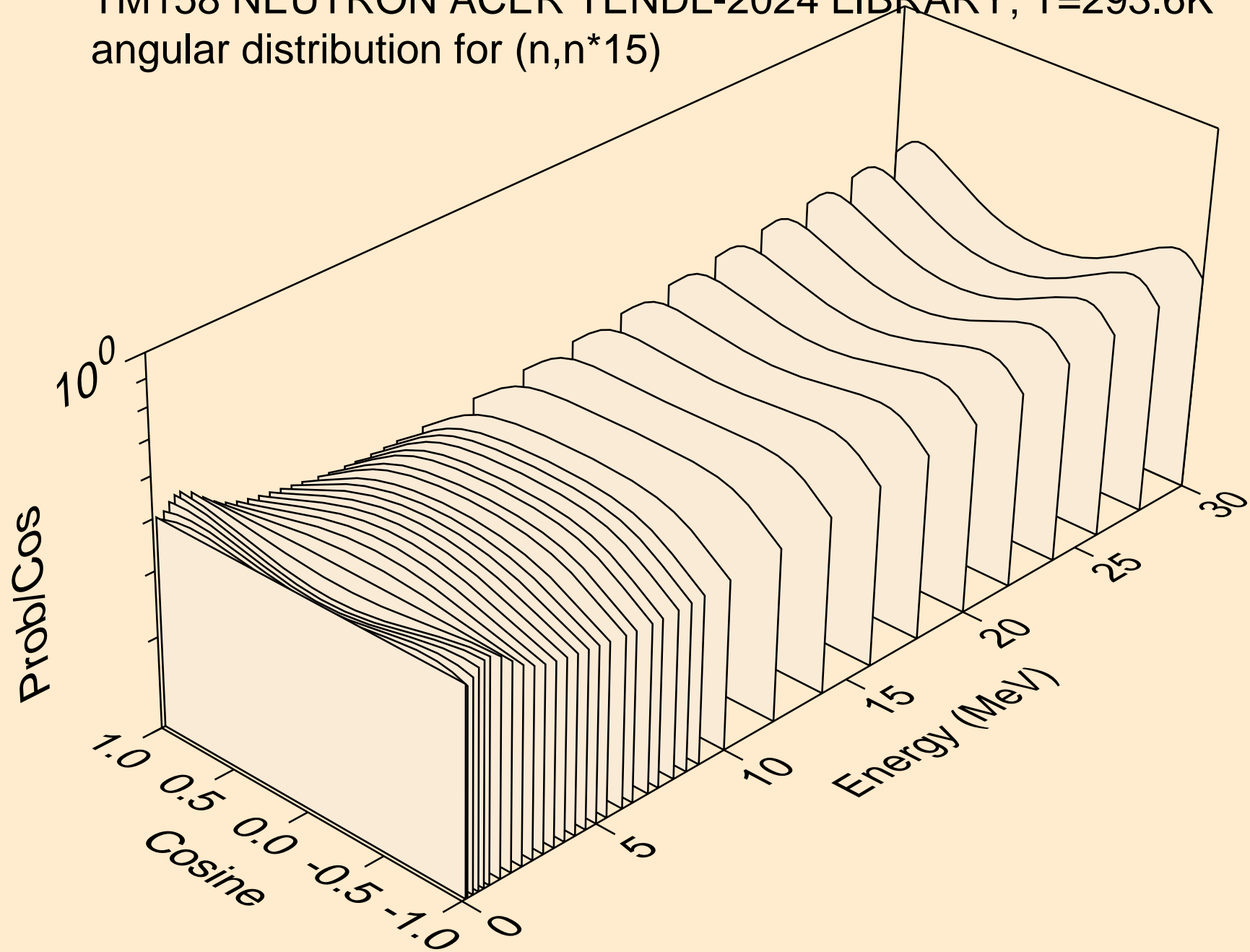

TM158 NEUTRON ACER TENDL-2024 LIBRARY; T=293.6K
angular distribution for (n,n*16)

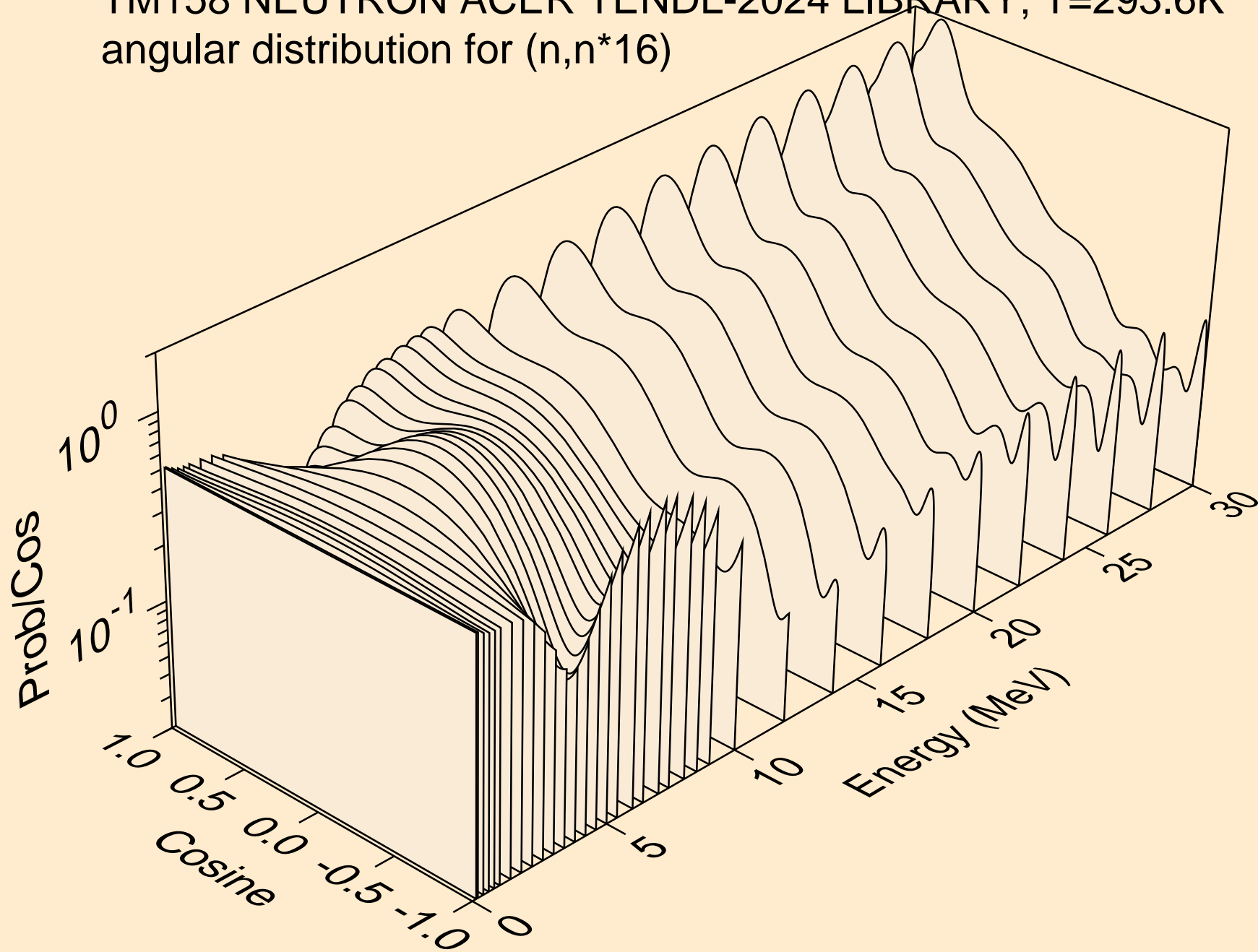

TM158 NEUTRON ACER TENDL-2024 LIBRARY; T=293.6K
angular distribution for (n,n*17)

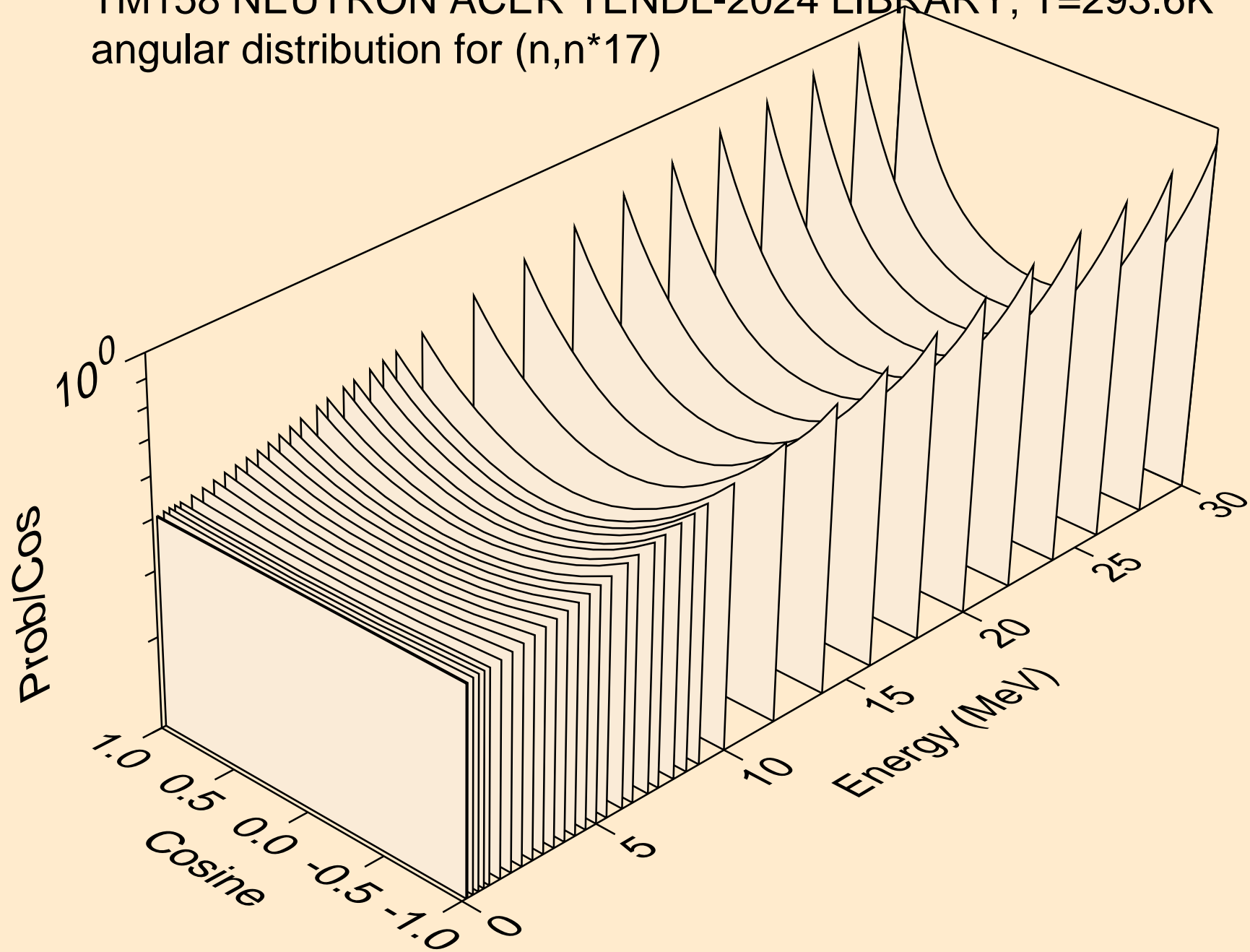

TM158 NEUTRON ACER TENDL-2024 LIBRARY; T=293.6K
angular distribution for (n,n*18)

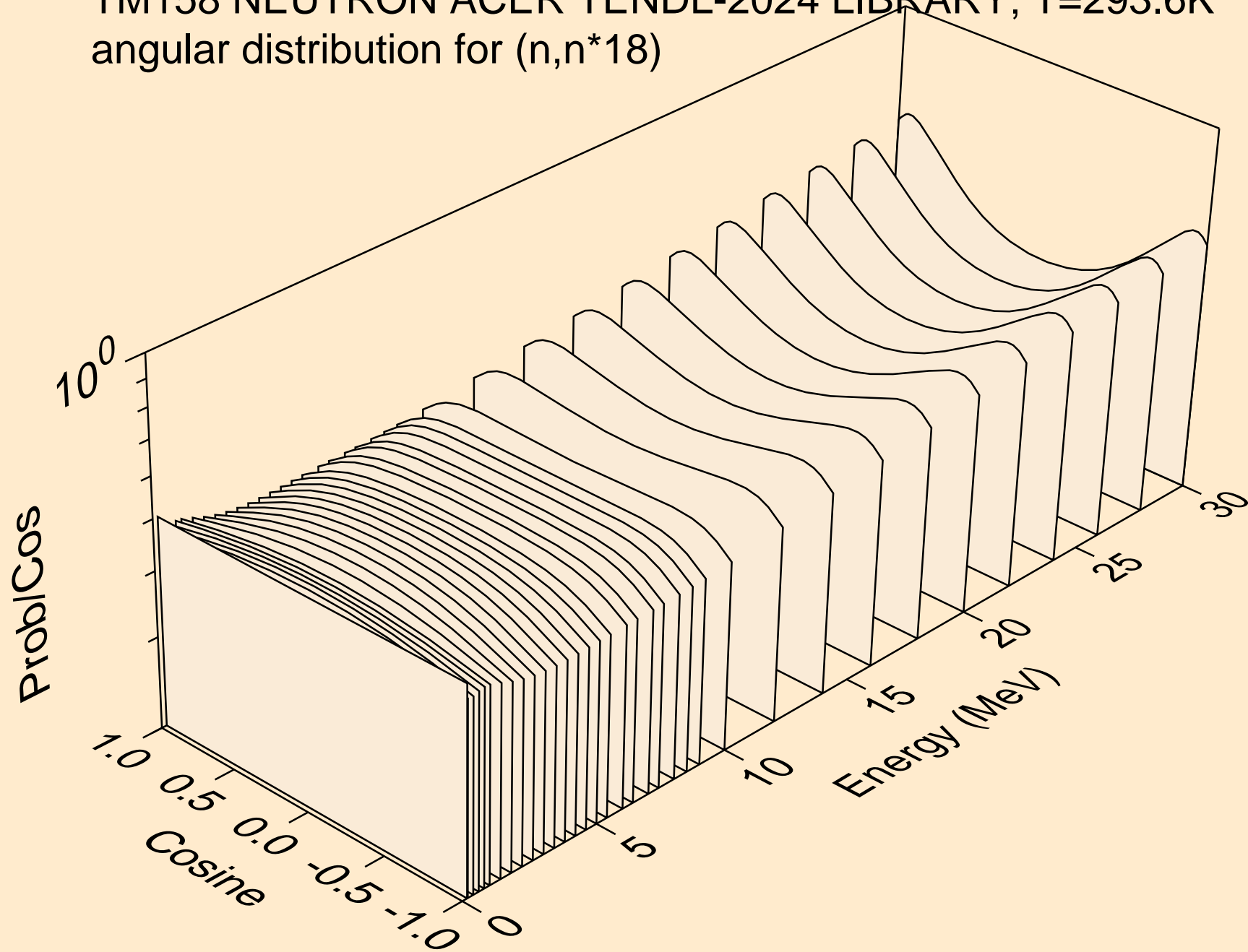

TM158 NEUTRON ACER TENDL-2024 LIBRARY; T=293.6K
angular distribution for (n,n*19)

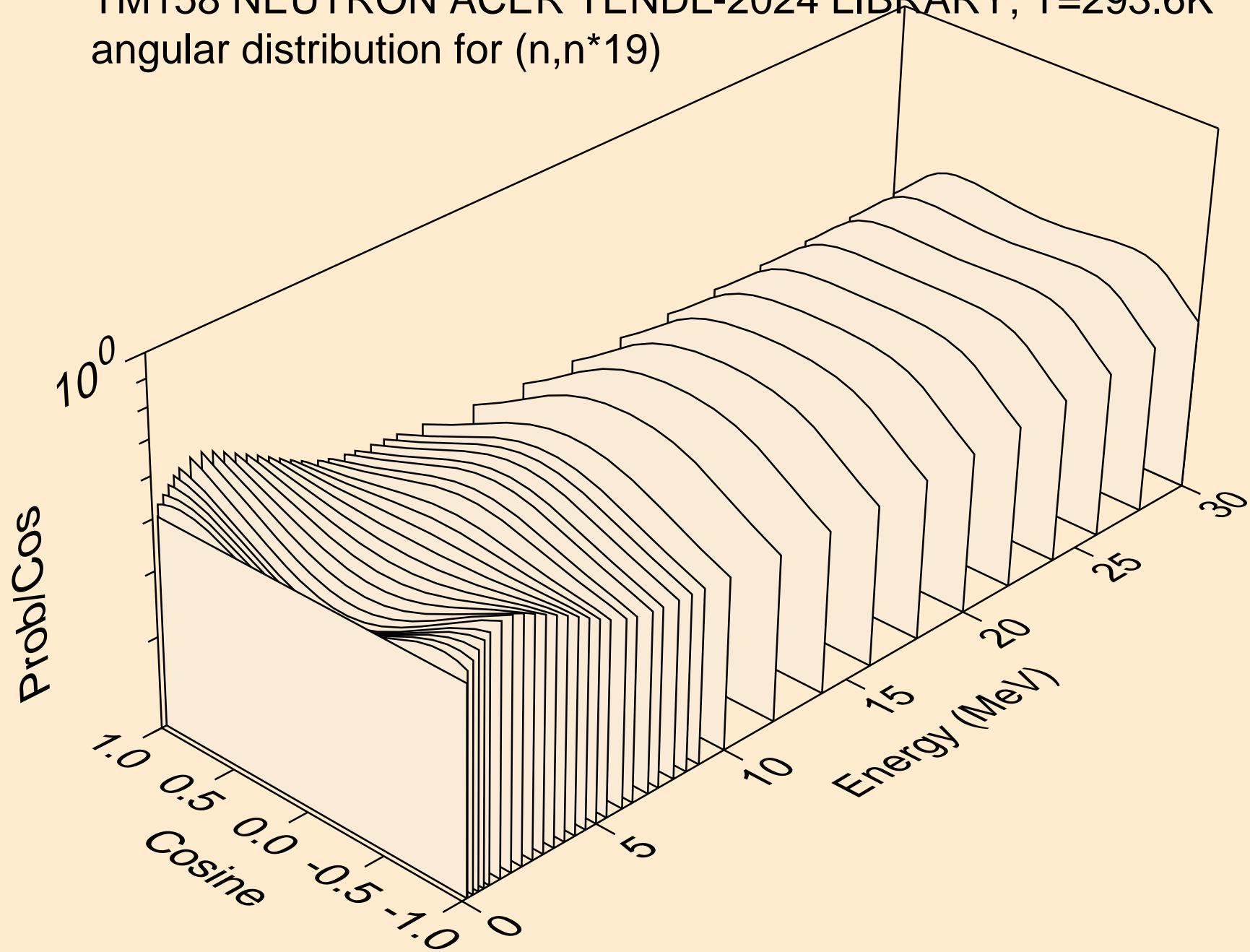

TM158 NEUTRON ACER TENDL-2024 LIBRARY; T=293.6K
angular distribution for (n,n*20)

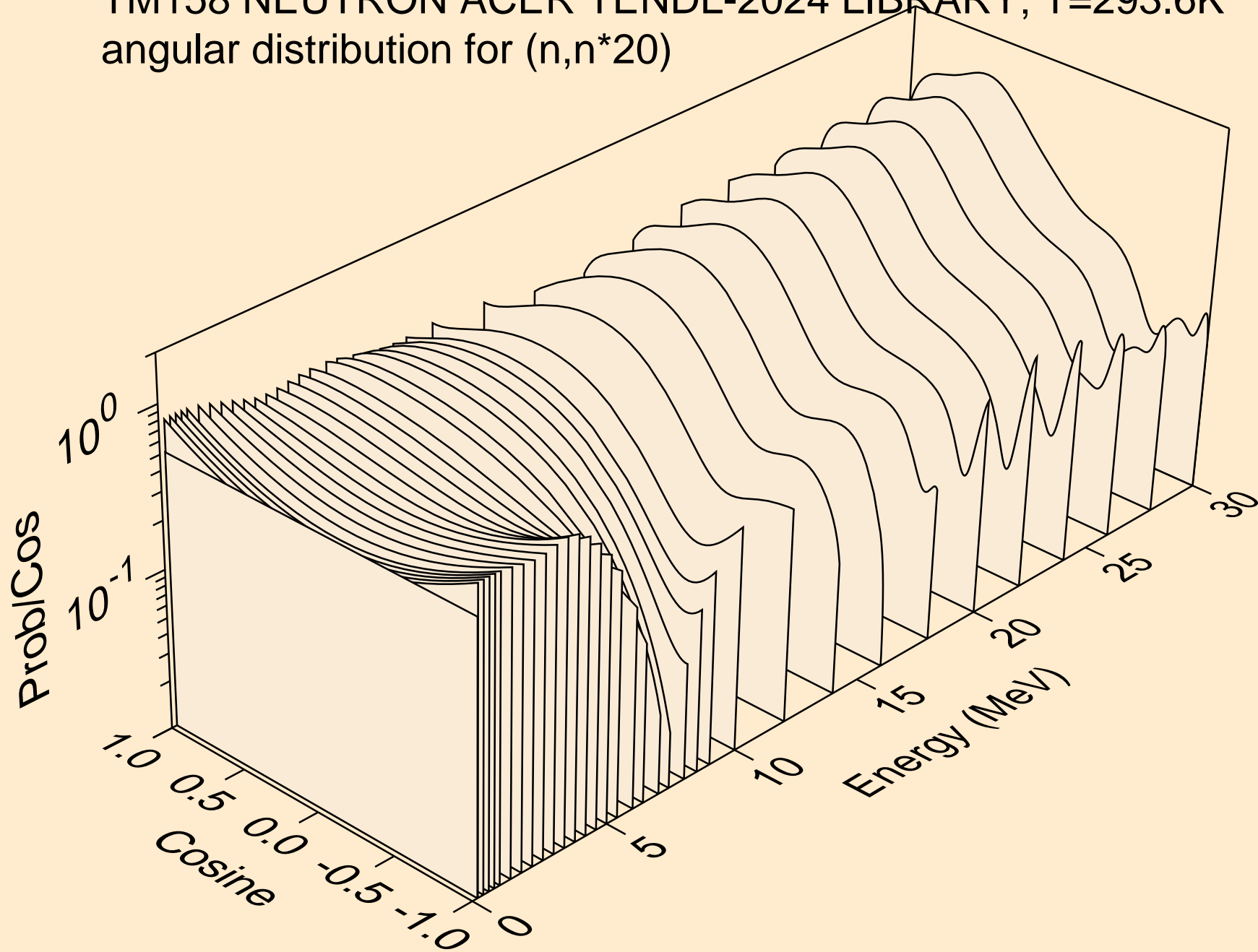

TM158 NEUTRON ACER TENDL-2024 LIBRARY; T=293.6K
angular distribution for (n,n*21)

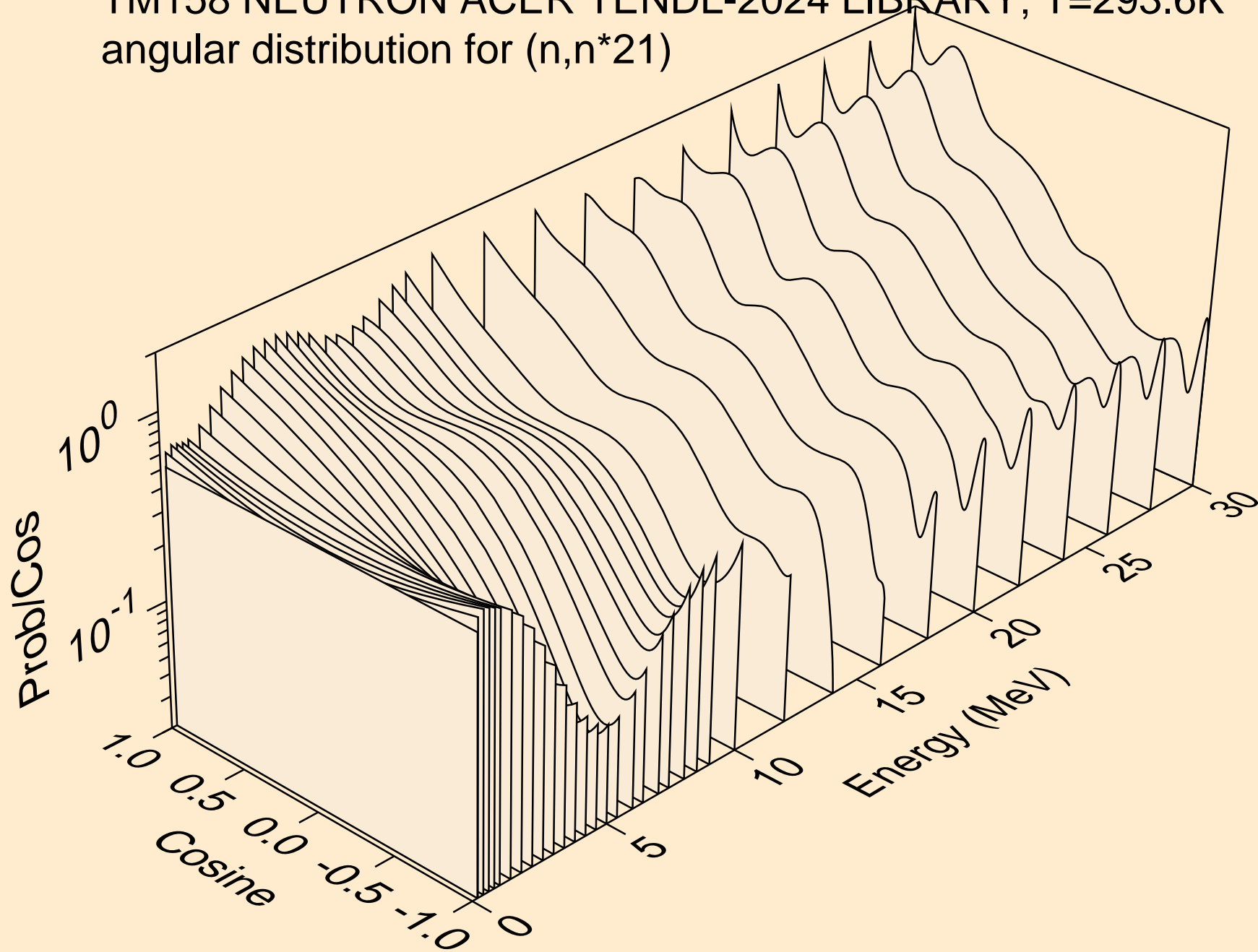

TM158 NEUTRON ACER TENDL-2024 LIBRARY; T=293.6K
angular distribution for (n,n*22)

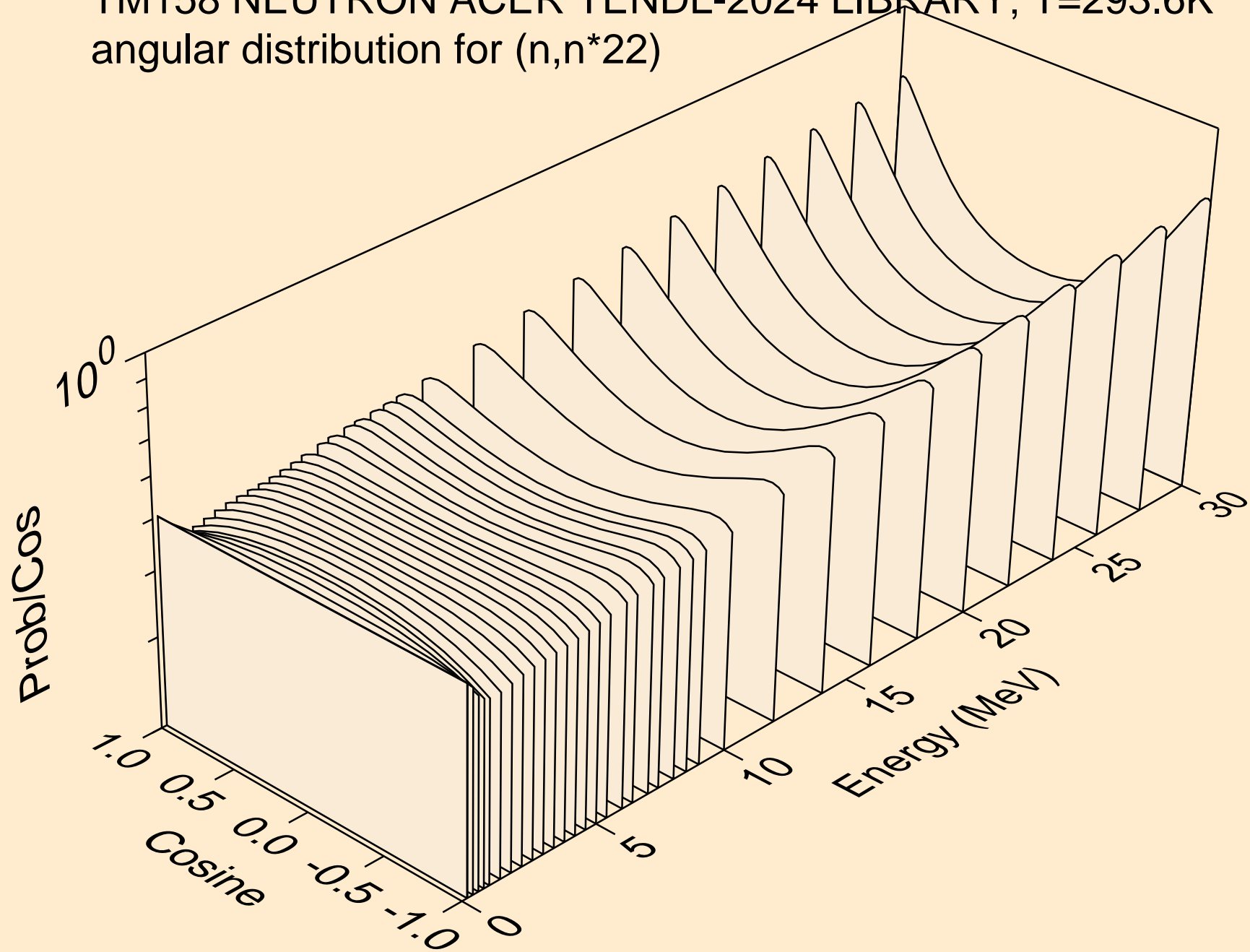

TM158 NEUTRON ACER TENDL-2024 LIBRARY; T=293.6K
angular distribution for (n,n*23)

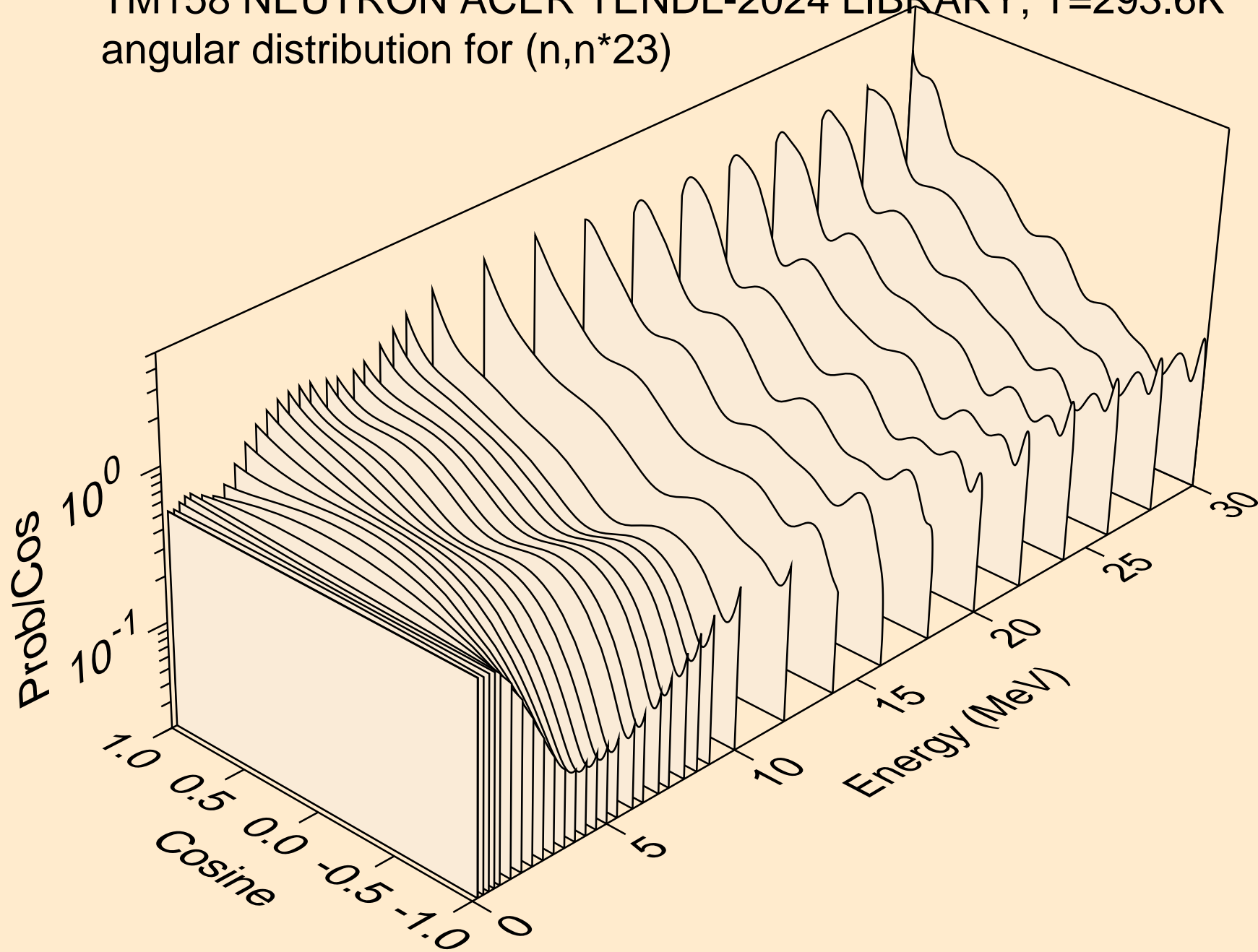

TM158 NEUTRON ACER TENDL-2024 LIBRARY; T=293.6K
angular distribution for (n,n*24)

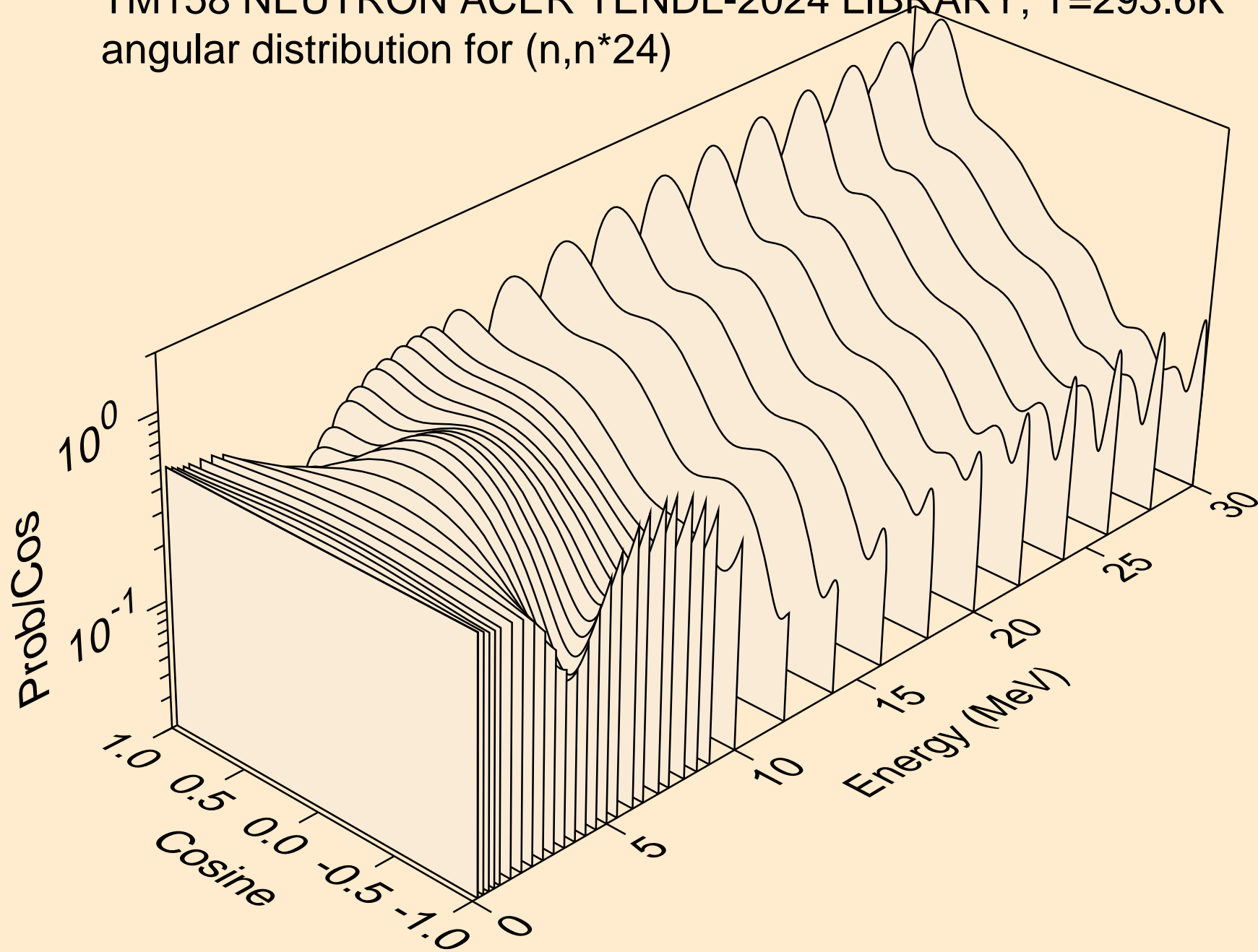

TM158 NEUTRON ACER TENDL-2024 LIBRARY; T=293.6K
angular distribution for (n,n*25)

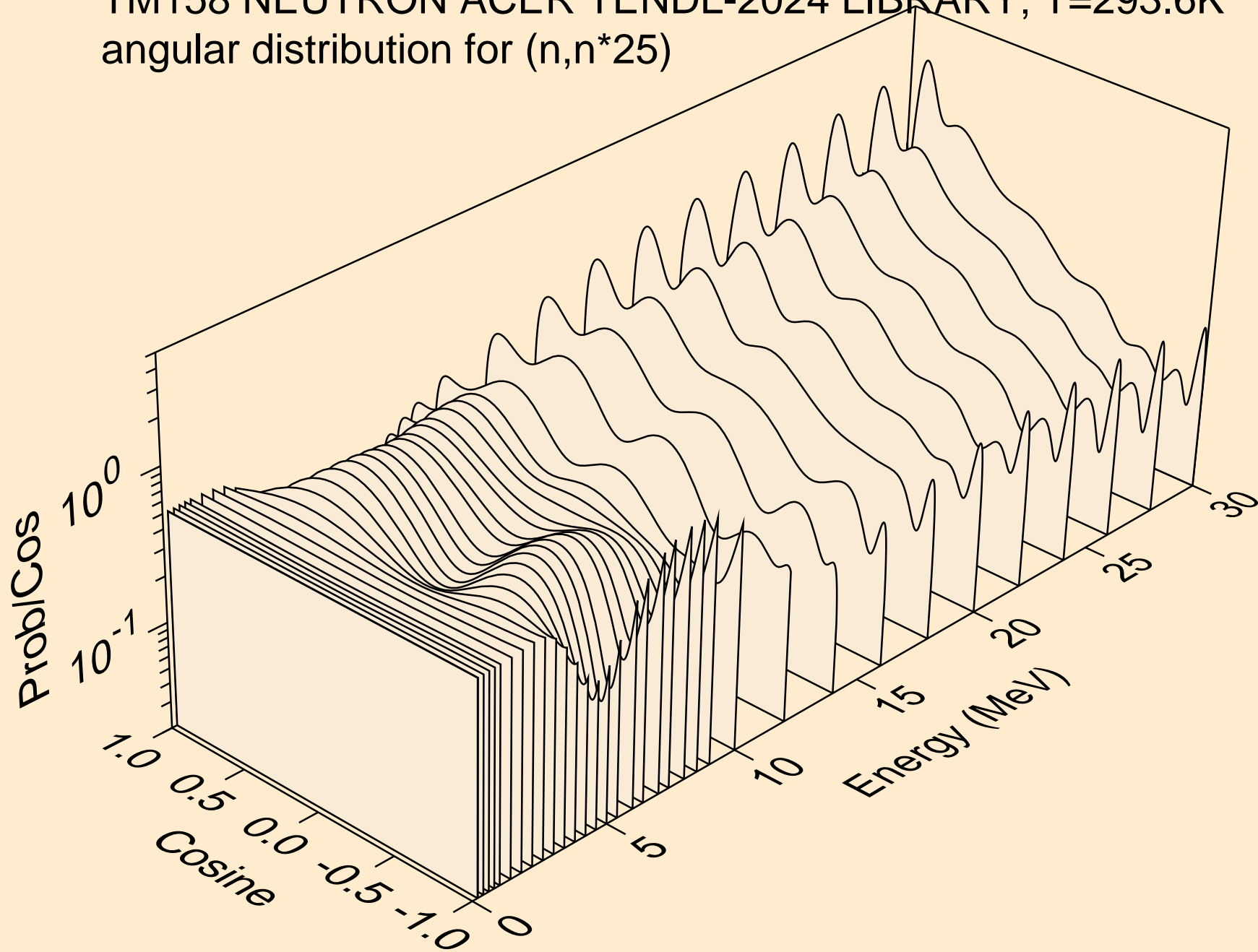

TM158 NEUTRON ACER TENDL-2024 LIBRARY; T=293.6K
angular distribution for (n,n*26)

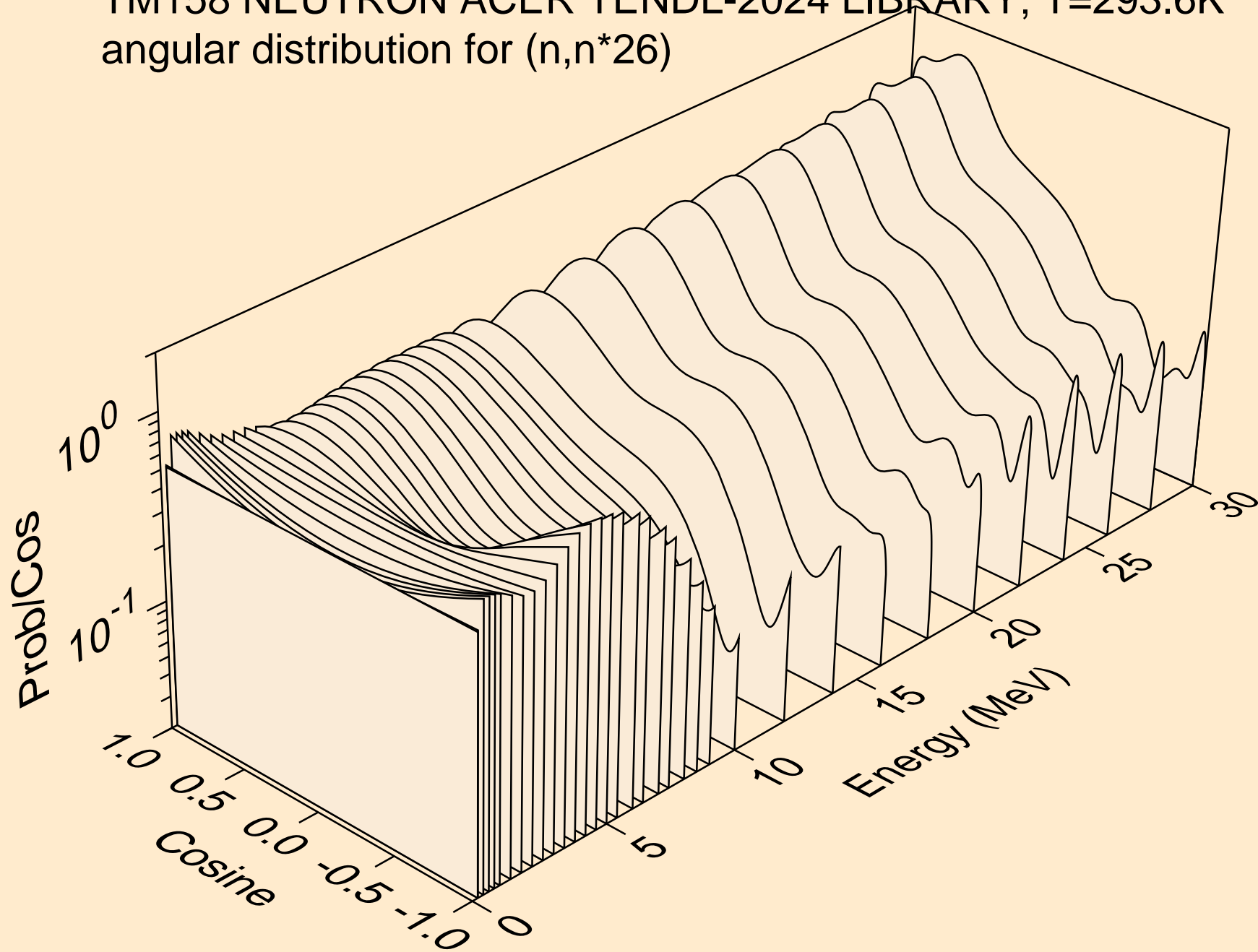

TM158 NEUTRON ACER TENDL-2024 LIBRARY; T=293.6K
angular distribution for (n,n*27)

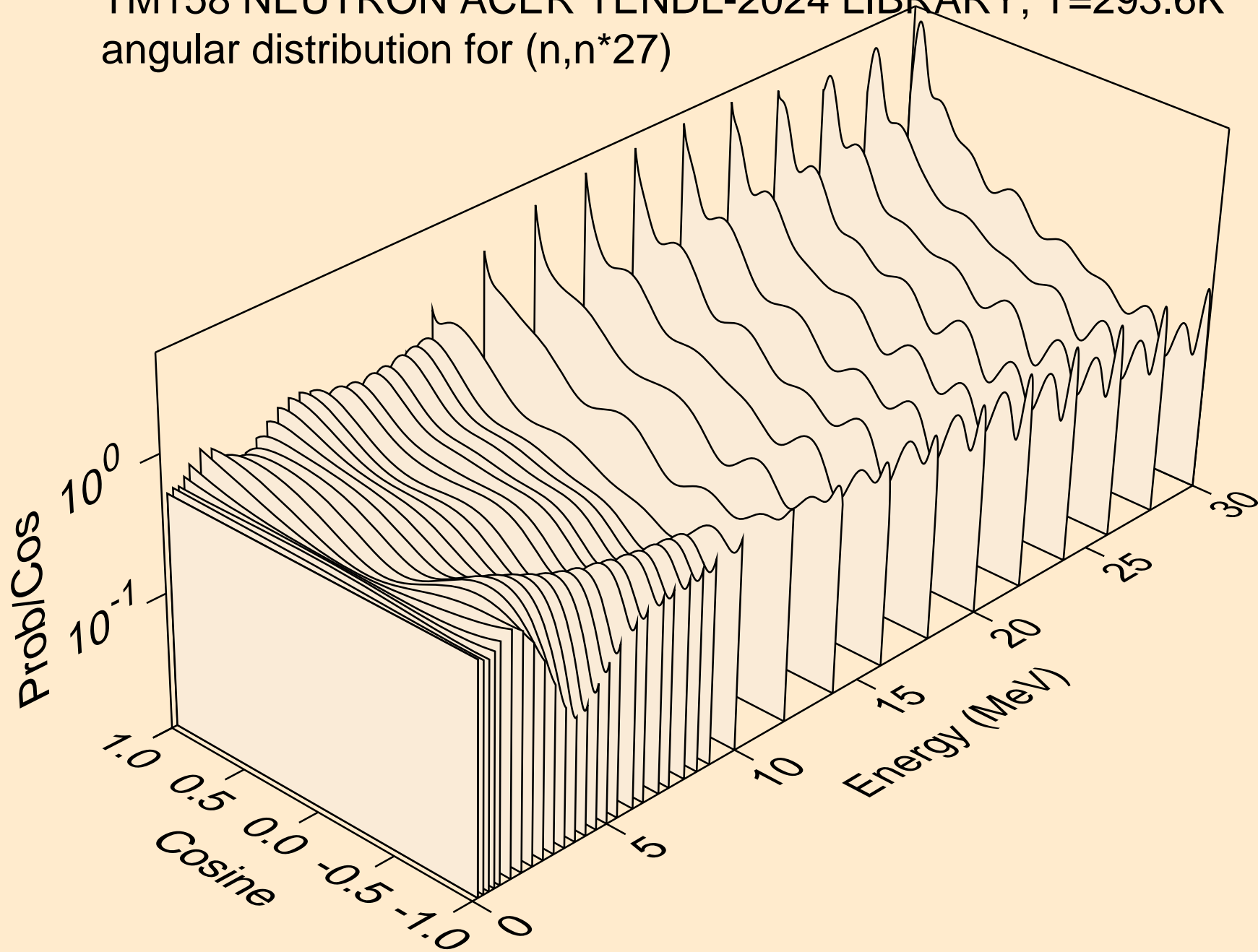

TM158 NEUTRON ACER TENDL-2024 LIBRARY; T=293.6K
angular distribution for (n,n*28)

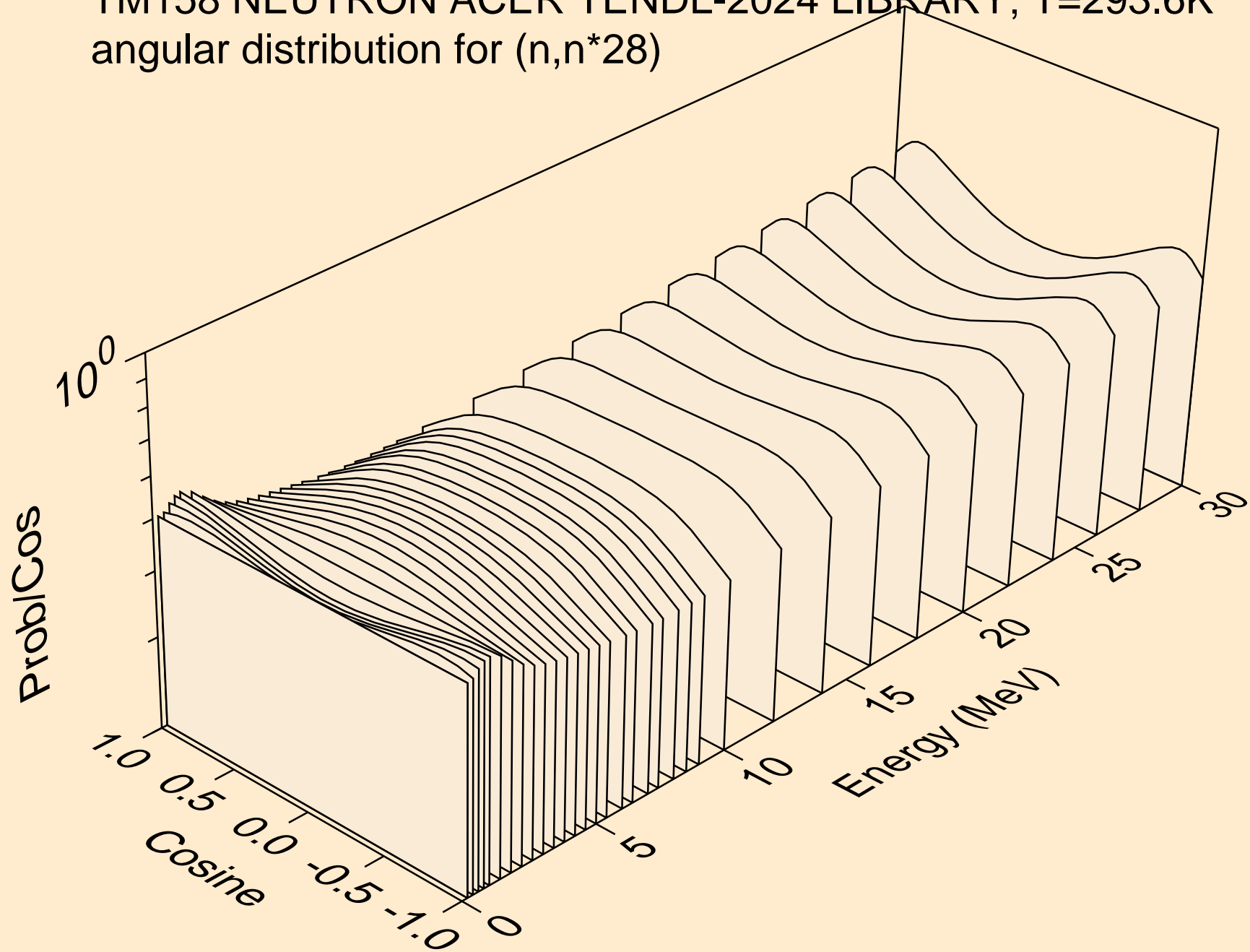

TM158 NEUTRON ACER TENDL-2024 LIBRARY; T=293.6K
angular distribution for (n,n*29)

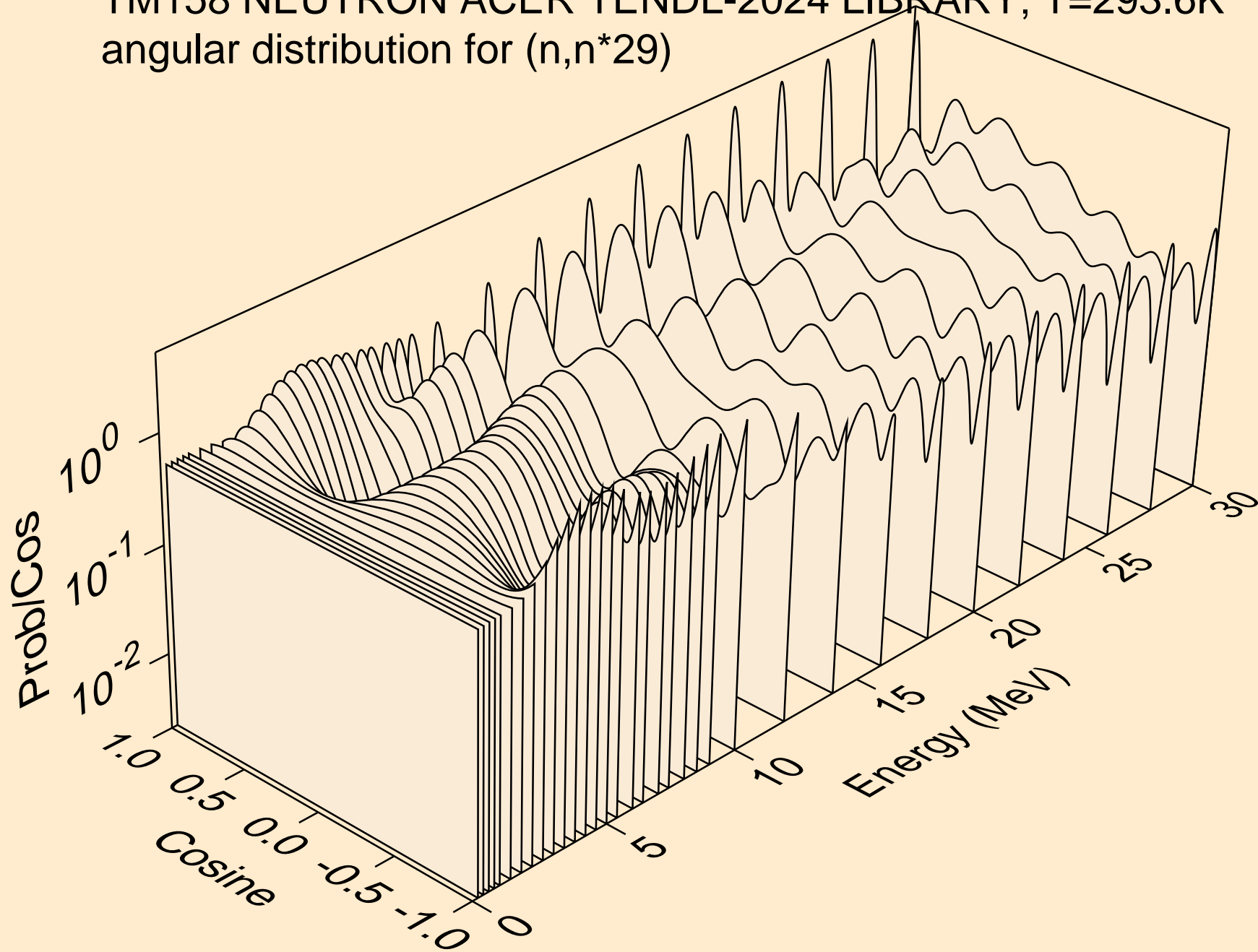

TM158 NEUTRON ACER TENDL-2024 LIBRARY; T=293.6K
angular distribution for (n,n*30)

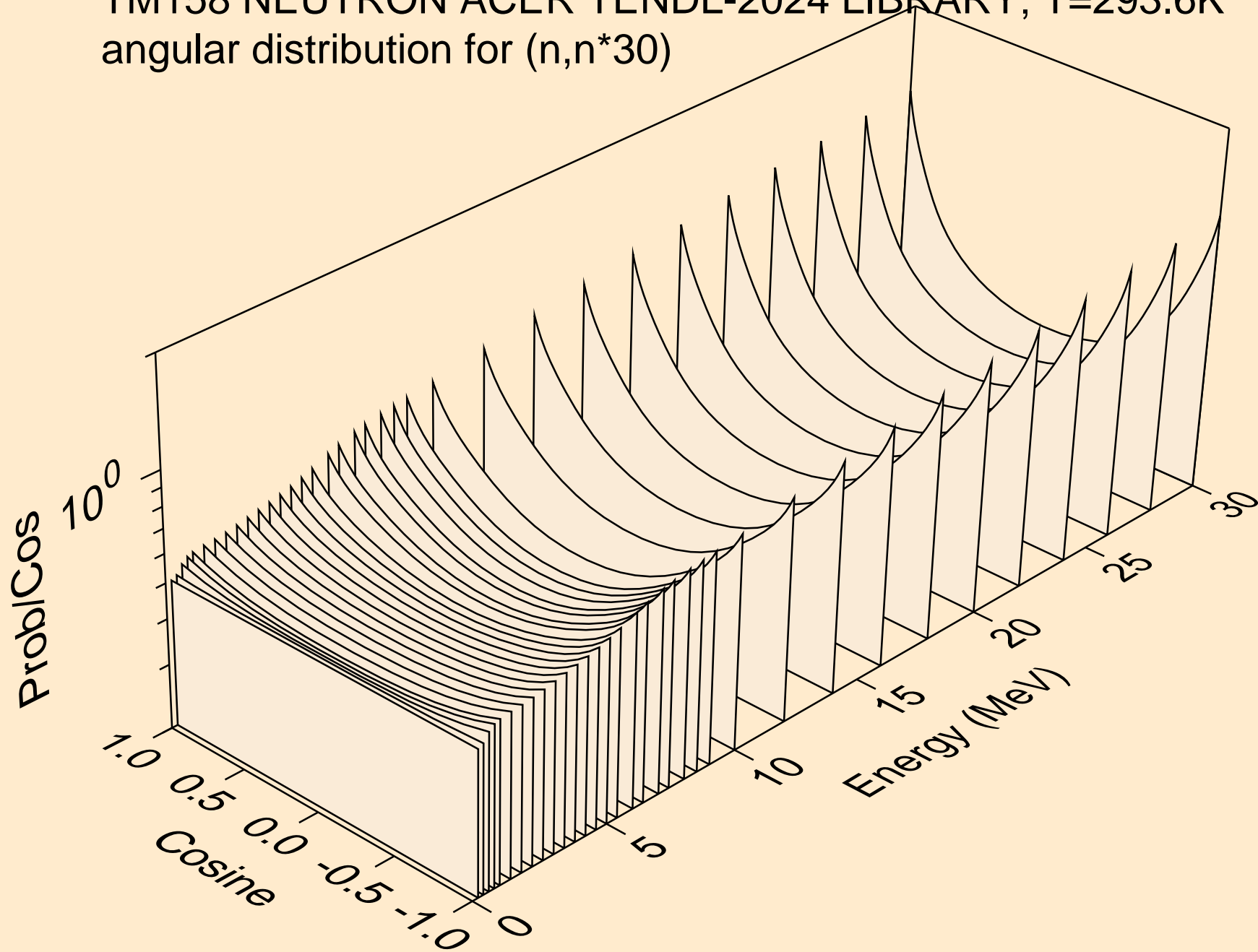

TM158 NEUTRON ACER TENDL-2024 LIBRARY; T=293.6K
Neutron emission for (n,x)

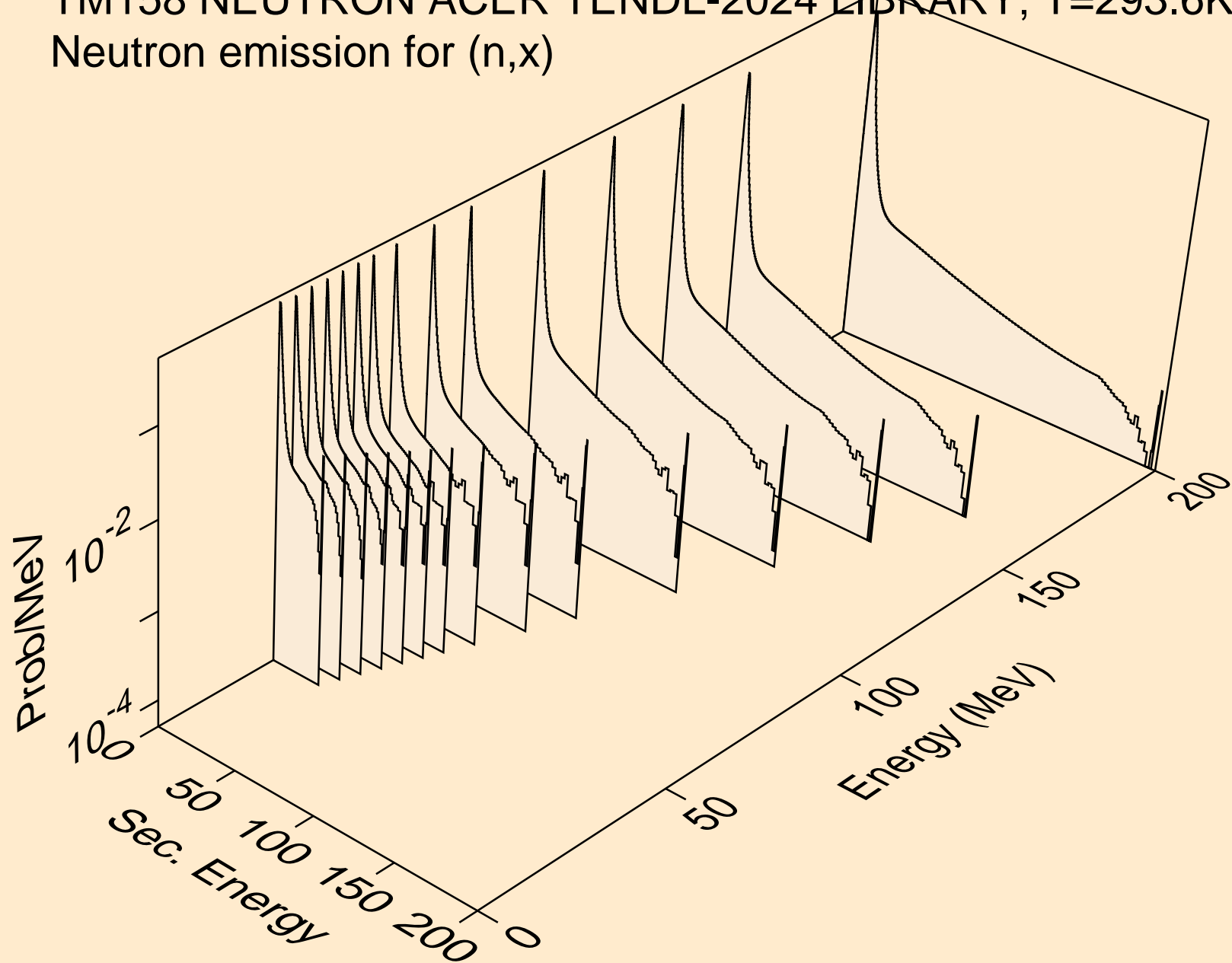

TM158 NEUTRON ACER TENDL-2024 LIBRARY; T=293.6K
Neutron emission for (n,2nd)

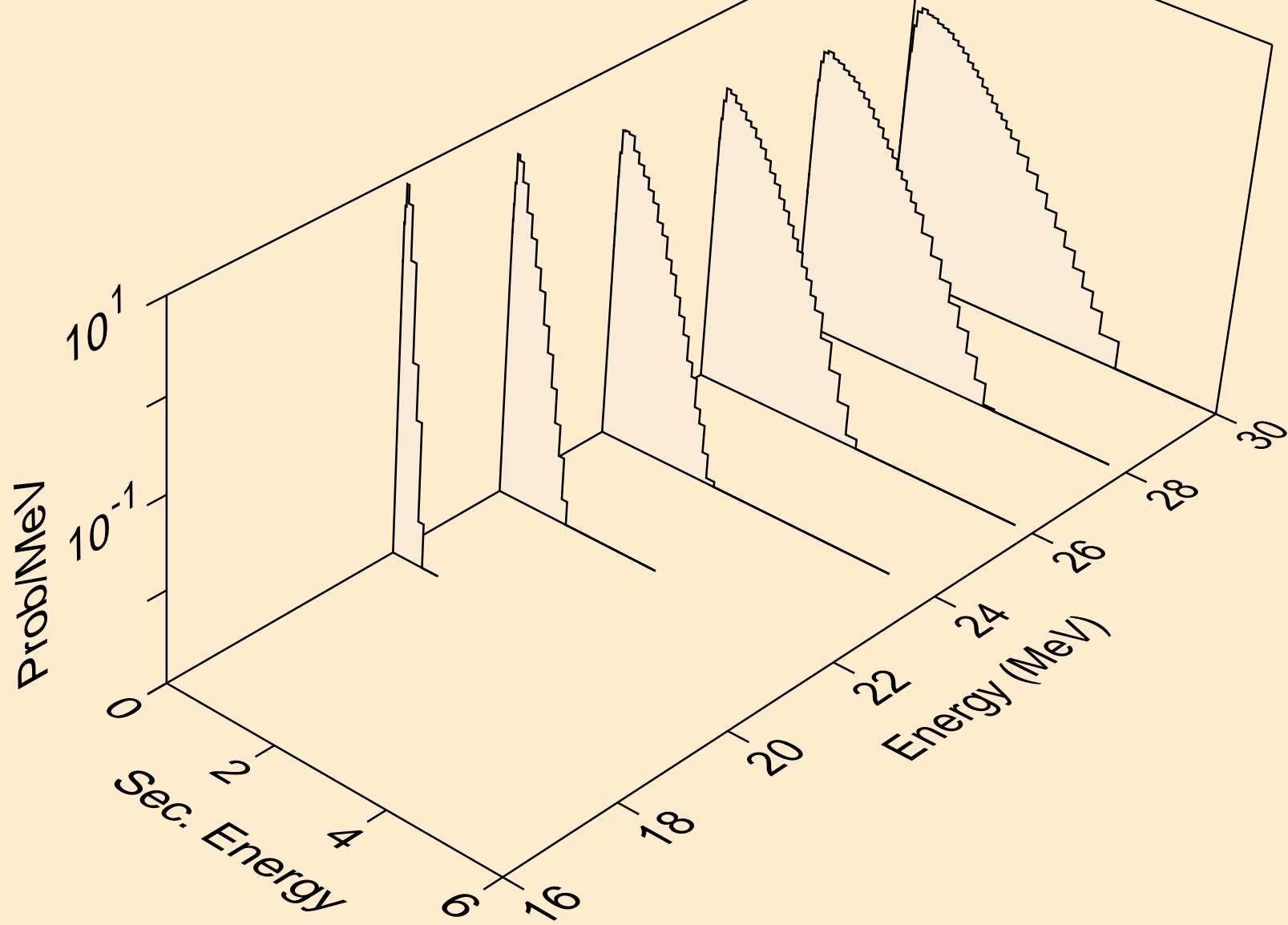

TM158 NEUTRON ACER TENDL-2024 LIBRARY; T=293.6K
Neutron emission for (n,2n)

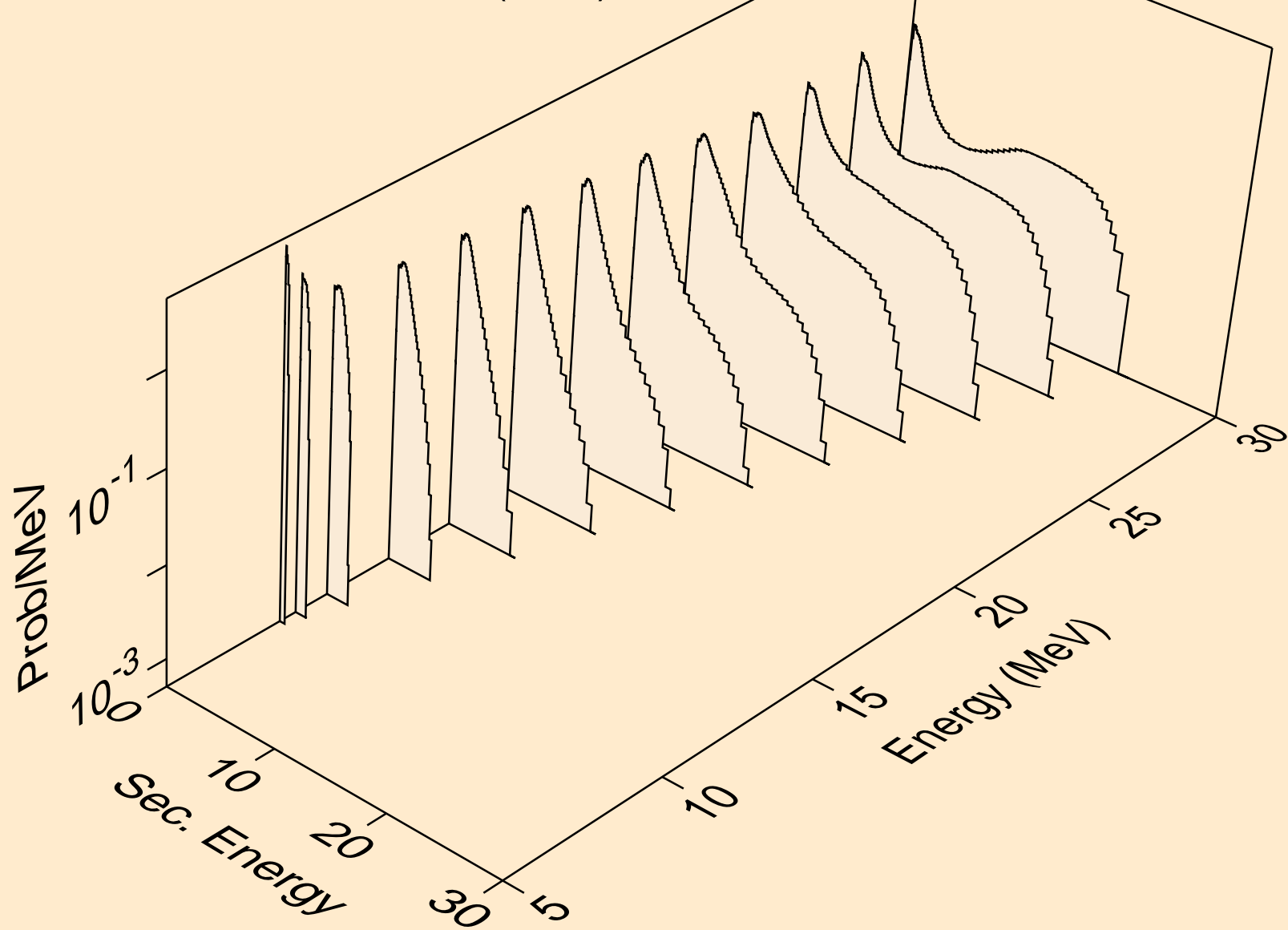

TM158 NEUTRON ACER TENDL-2024 LIBRARY; T=293.6K
Neutron emission for (n,3n)

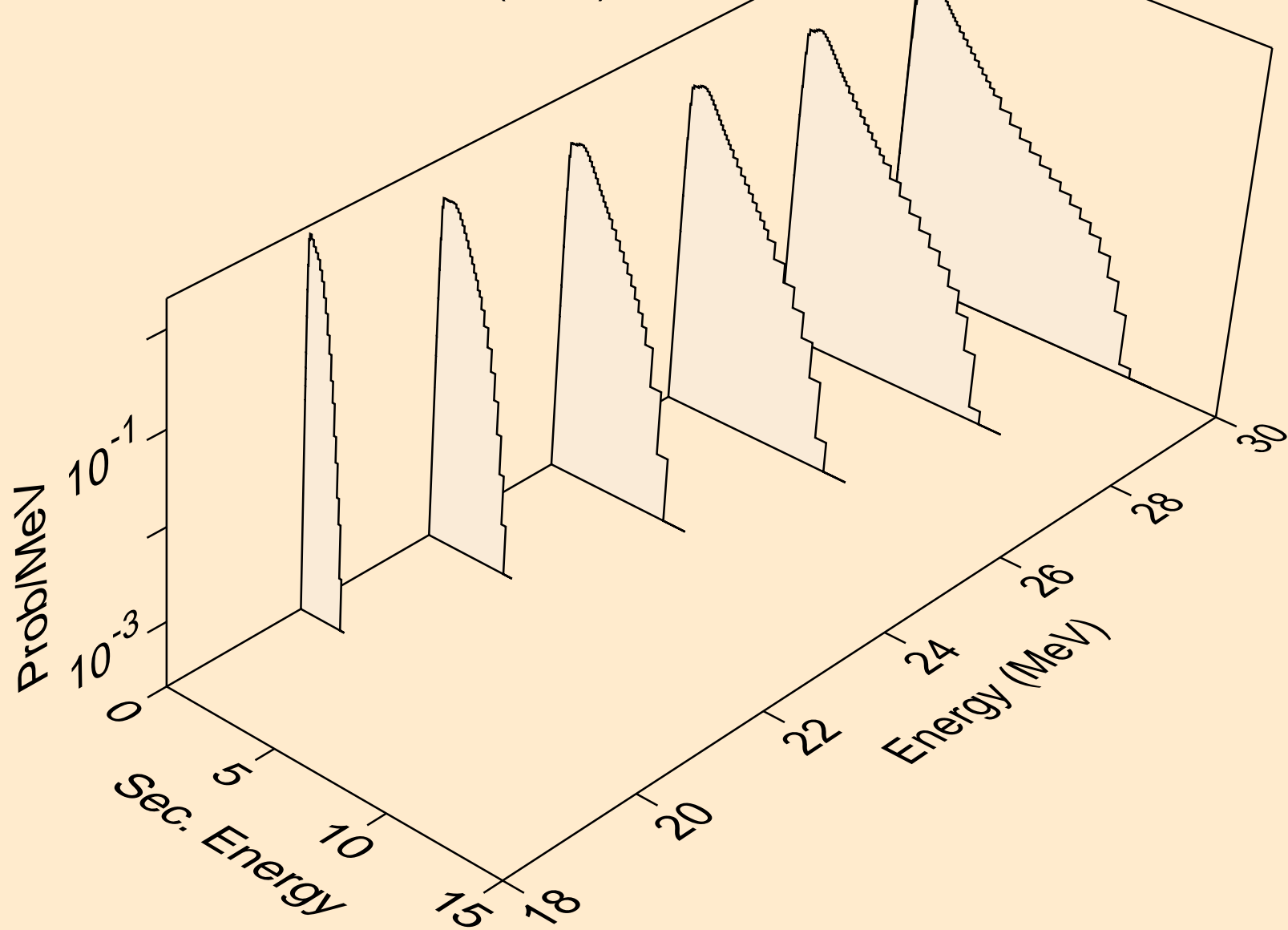

TM158 NEUTRON ACER TENDL-2024 LIBRARY; T=293.6K
Neutron emission for (n,n*)a

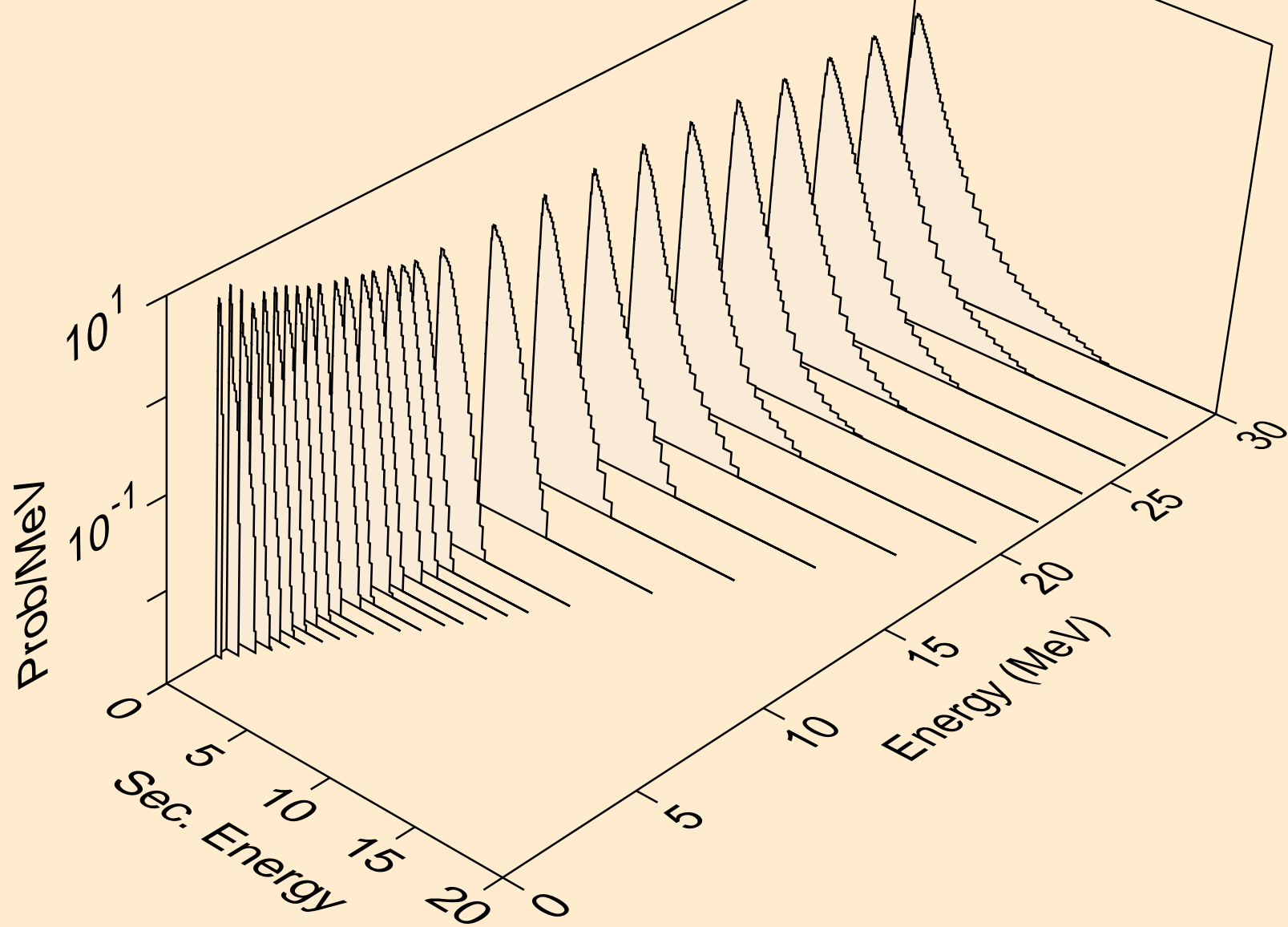

TM158 NEUTRON ACER TENDL-2024 LIBRARY; T=293.6K
Neutron emission for (n,n*)3a

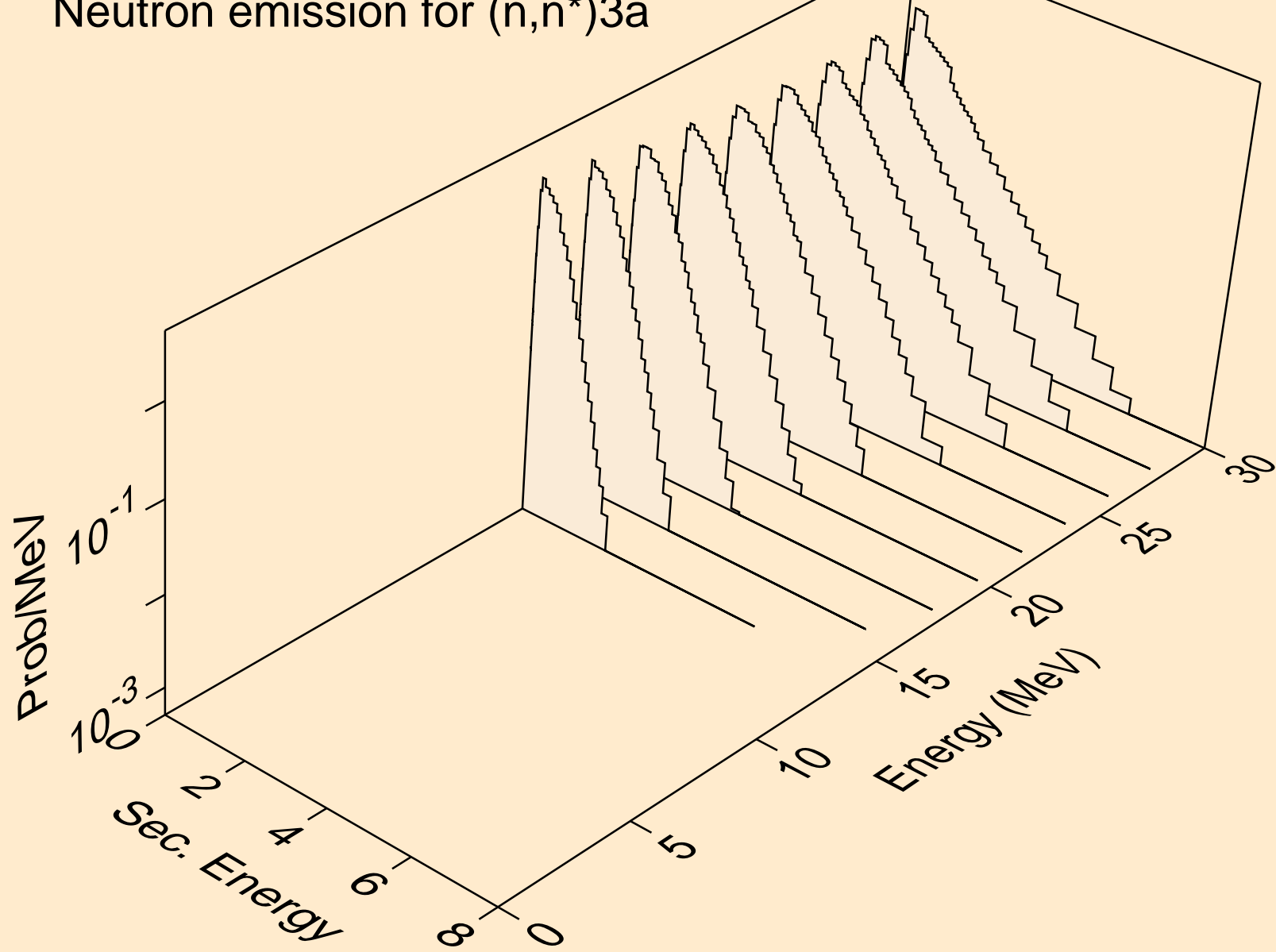

TM158 NEUTRON ACER TENDL-2024 LIBRARY; T=293.6K
Neutron emission for (n,2n)_a

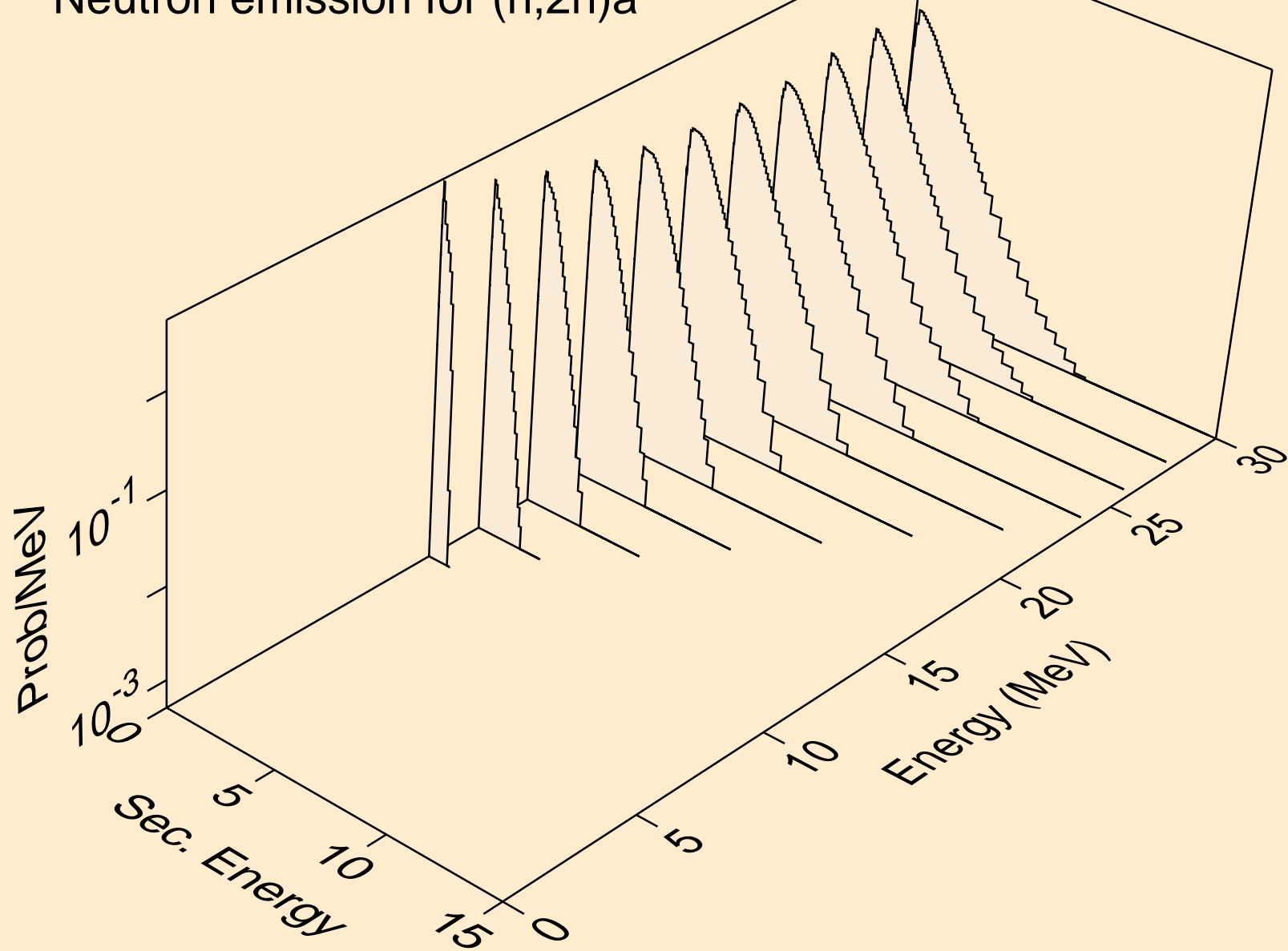

TM158 NEUTRON ACER TENDL-2024 LIBRARY; T=293.6K
Neutron emission for (n,3n)a

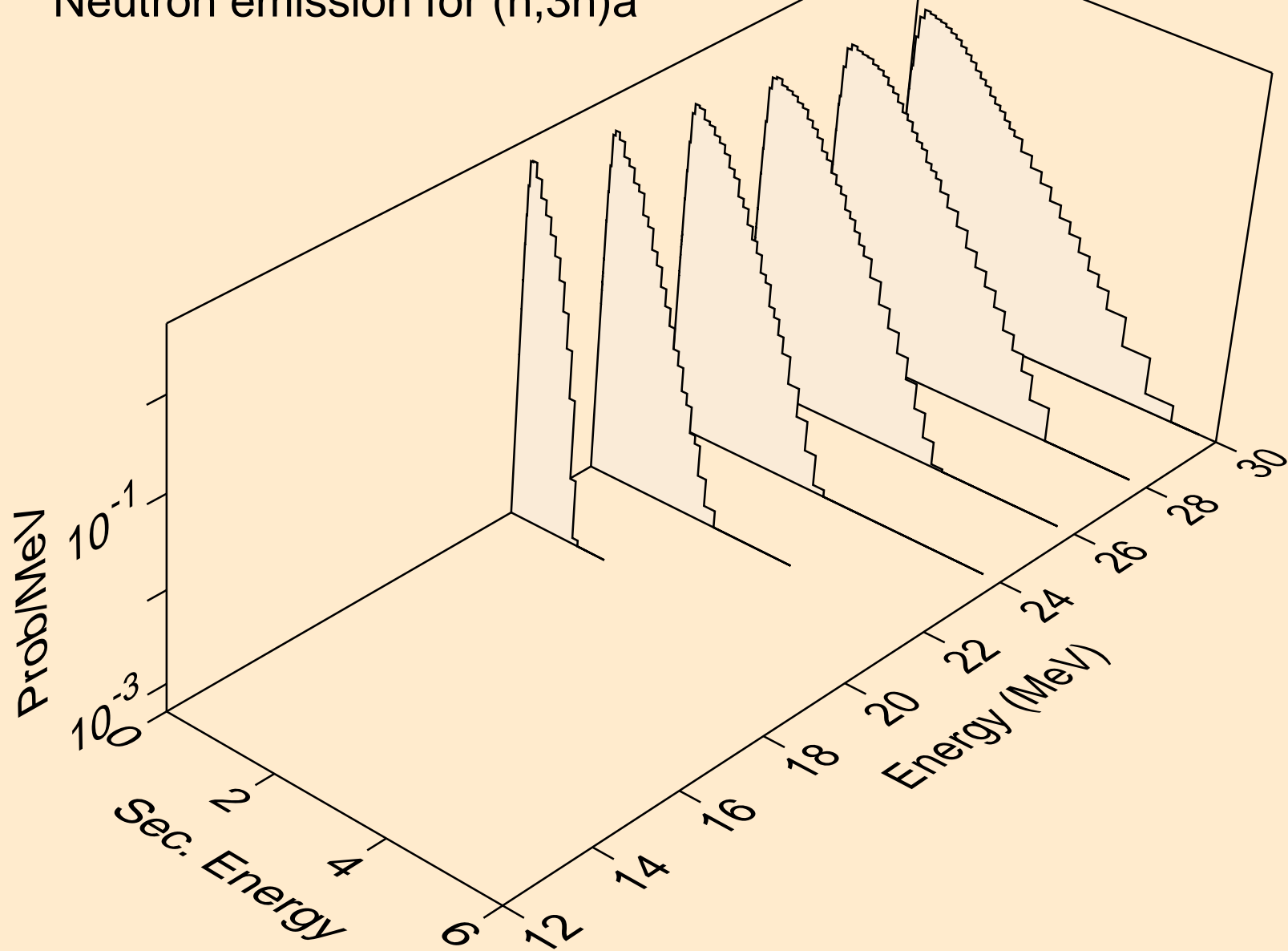

TM158 NEUTRON ACER TENDL-2024 LIBRARY; T=293.6K
Neutron emission for (n,n*)p

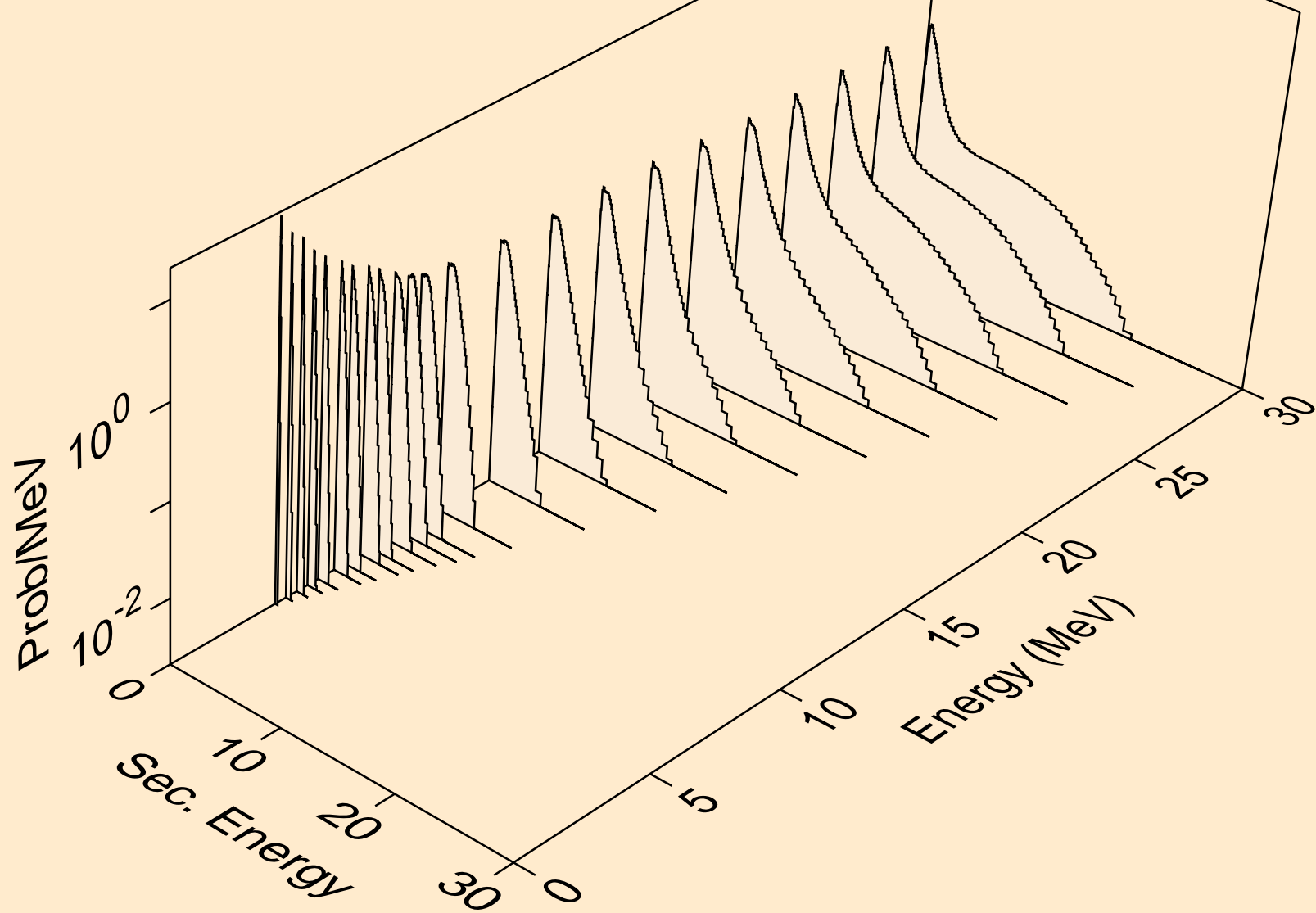

TM158 NEUTRON ACER TENDL-2024 LIBRARY; T=293.6K
Neutron emission for (n,n*)2a

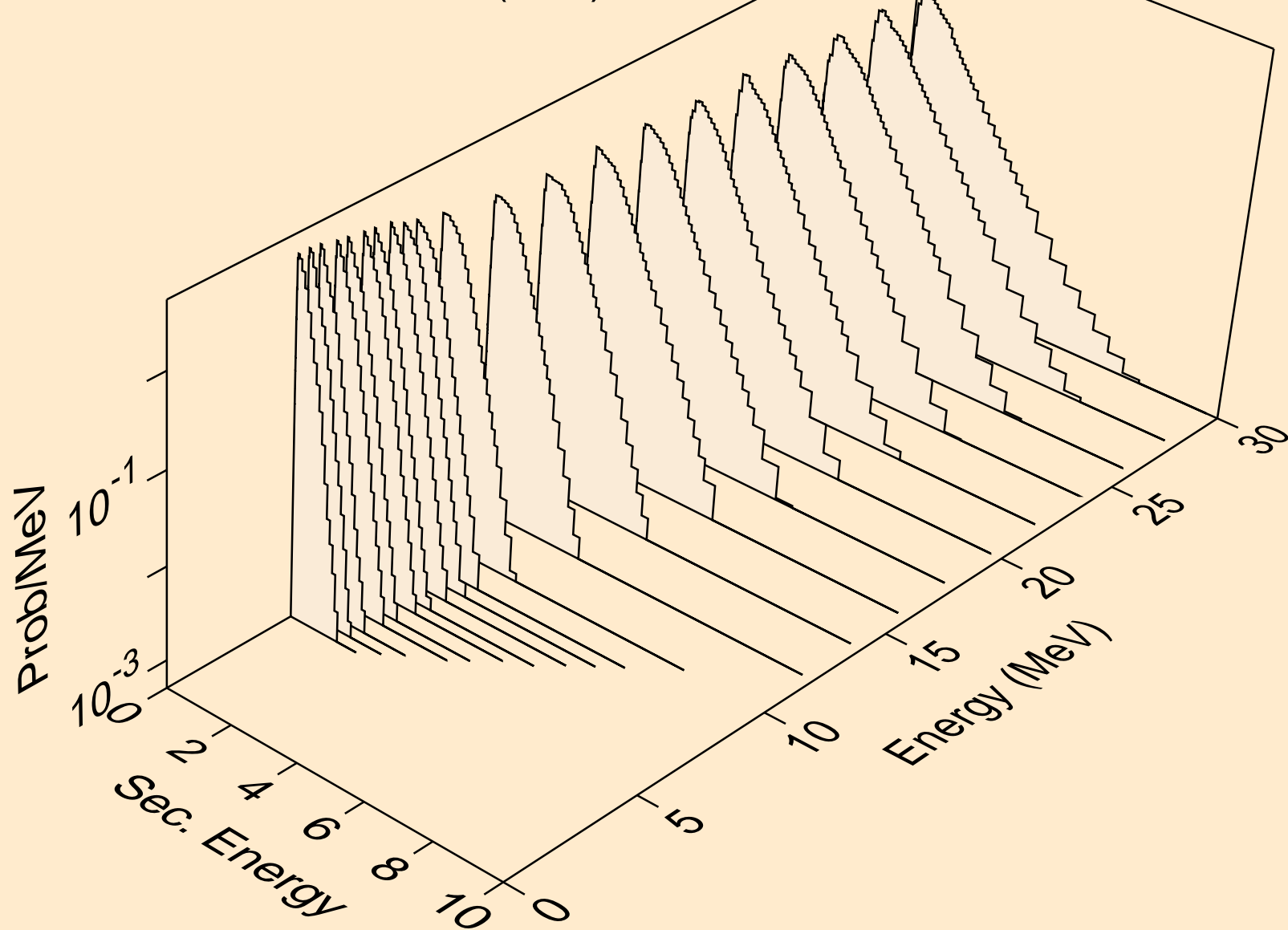

TM158 NEUTRON ACER TENDL-2024 LIBRARY; T=293.6K
Neutron emission for (n,2n)2a

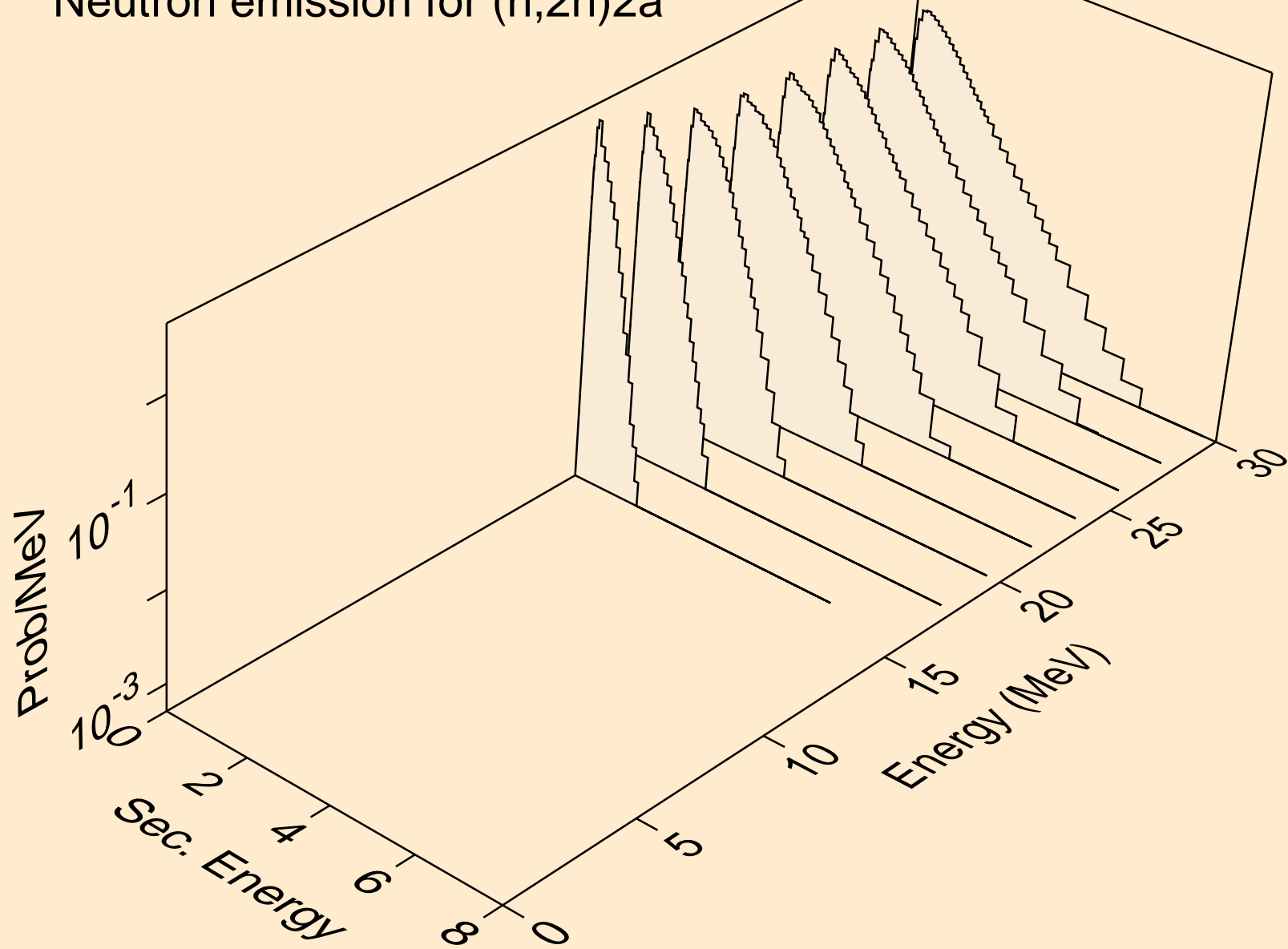

TM158 NEUTRON ACER TENDL-2024 LIBRARY; T=293.6K
Neutron emission for (n,n*)d

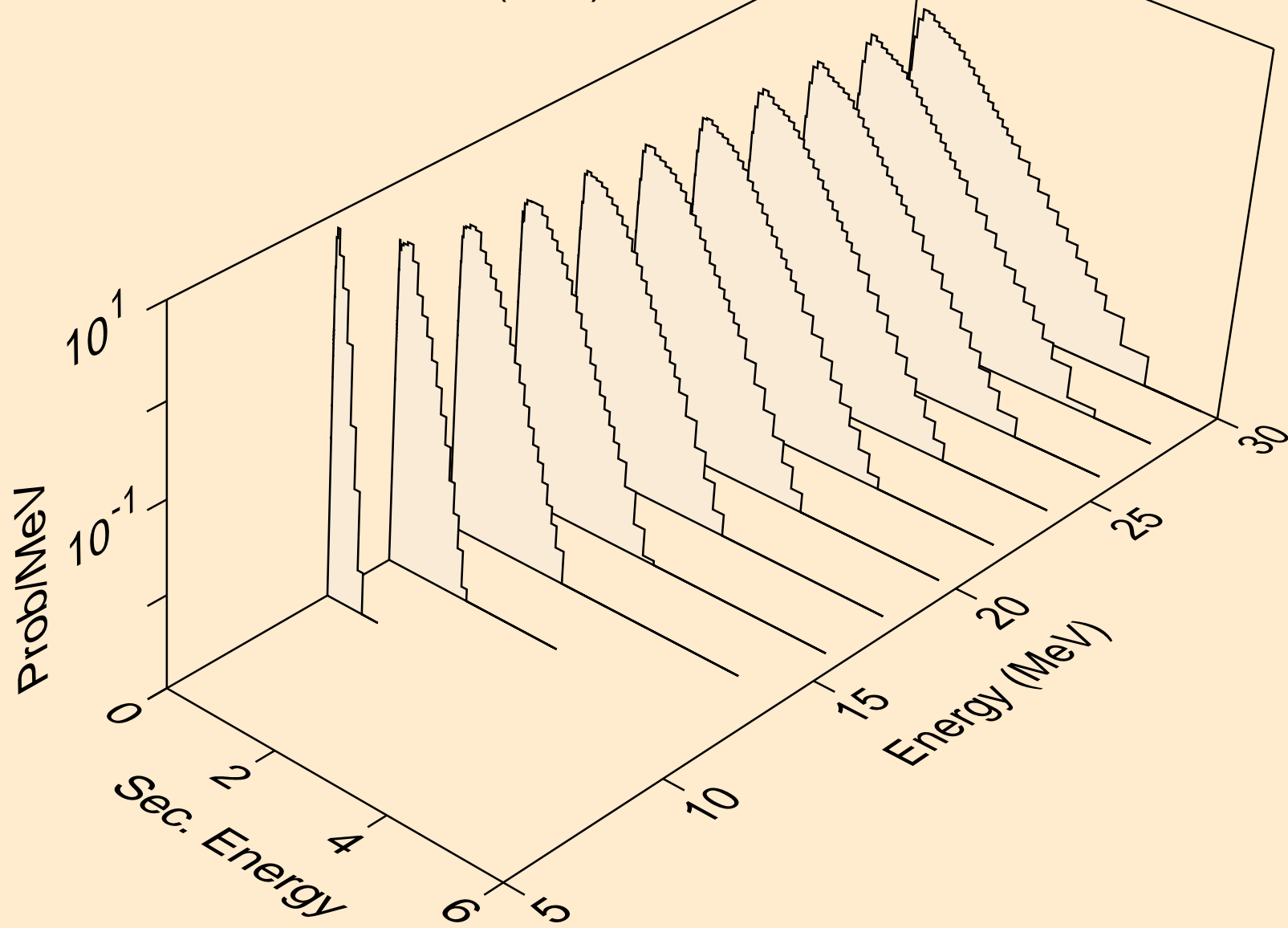

TM158 NEUTRON ACER TENDL-2024 LIBRARY; T=293.6K
Neutron emission for (n,n*)t

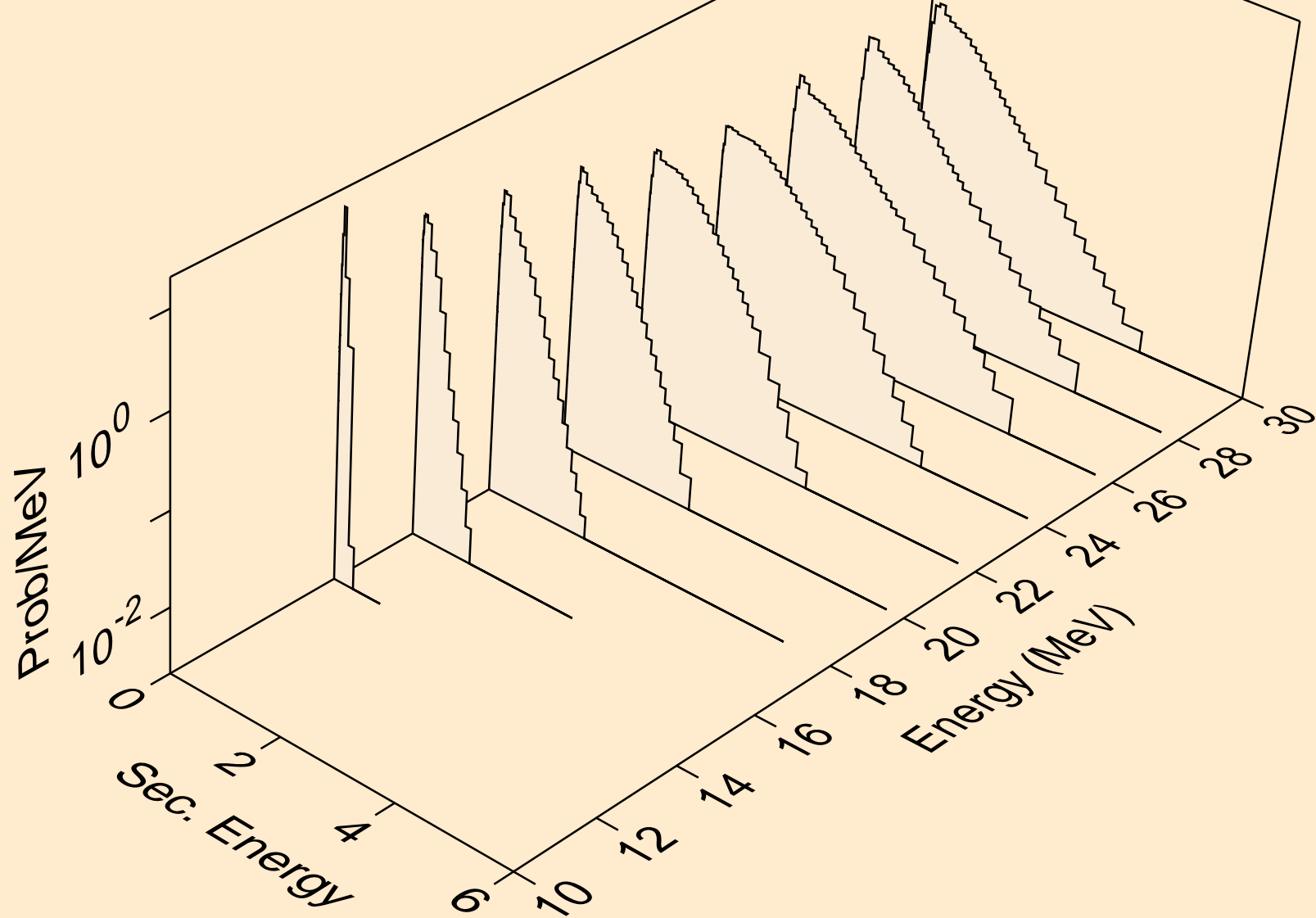

TM158 NEUTRON ACER TENDL-2024 LIBRARY; T=293.6K
Neutron emission for (n,n*)he3

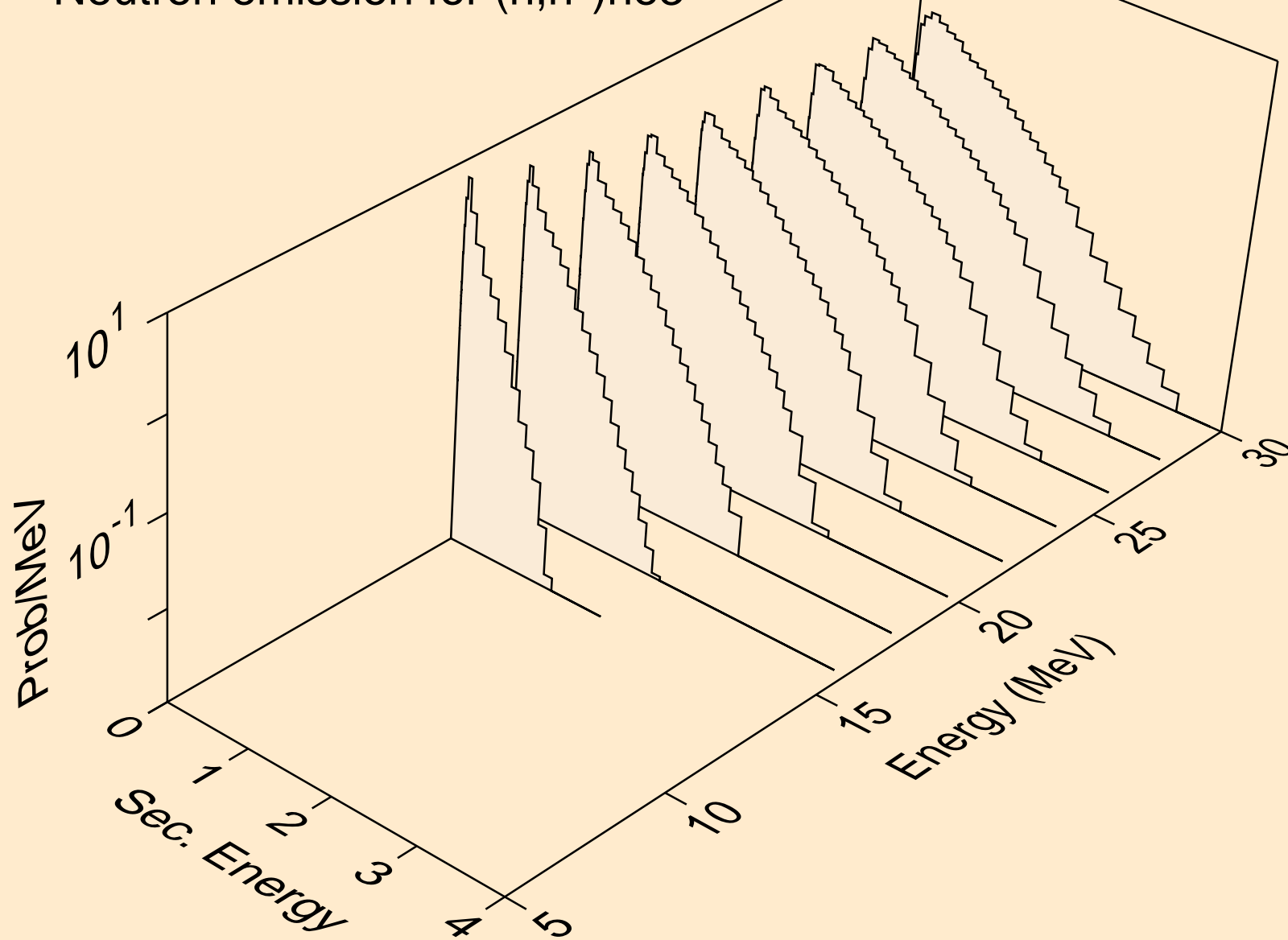

TM158 NEUTRON ACER TENDL-2024 LIBRARY; T=293.6K
Neutron emission for (n,4n)

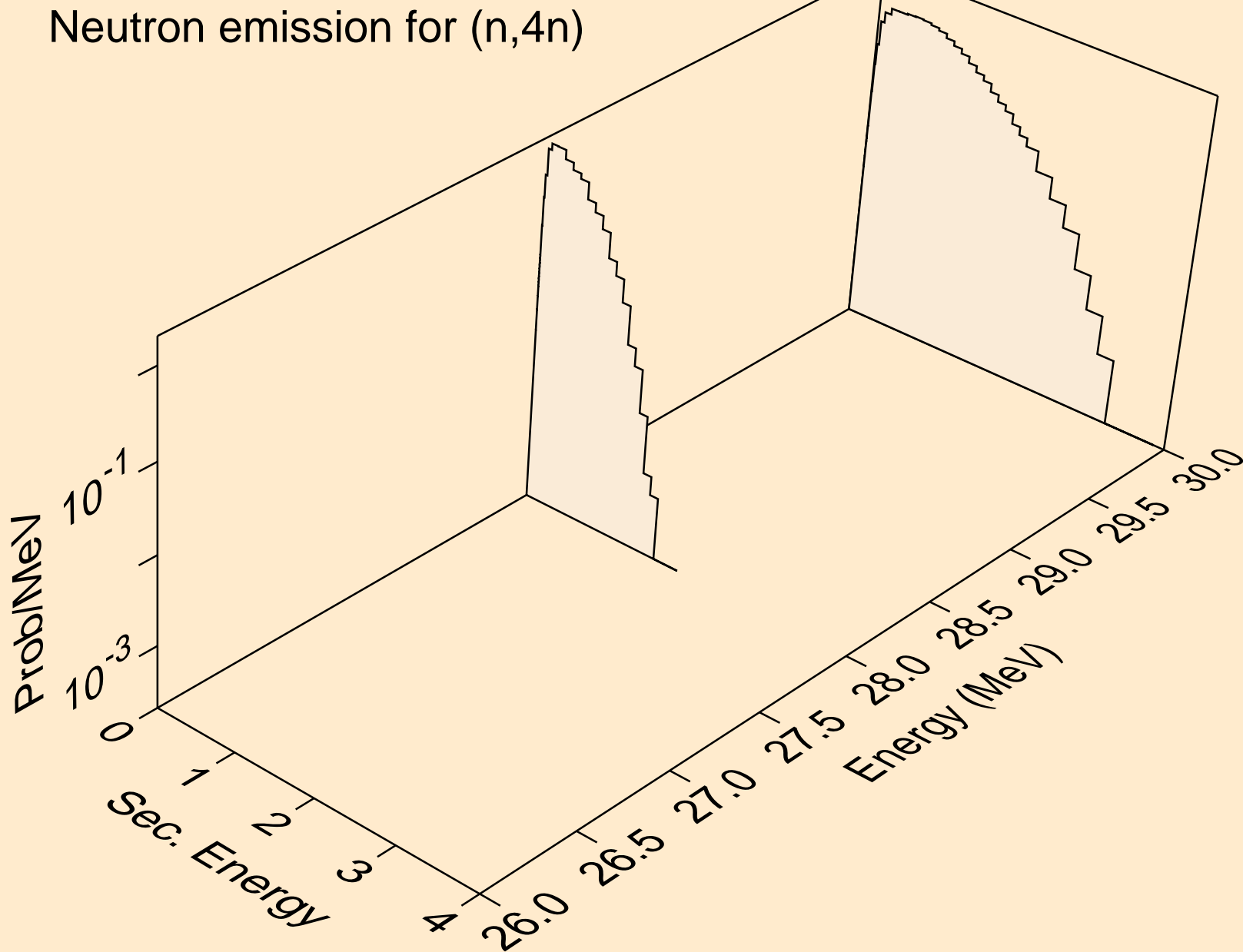

TM158 NEUTRON ACER TENDL-2024 LIBRARY; T=293.6K
Neutron emission for (n,2np)

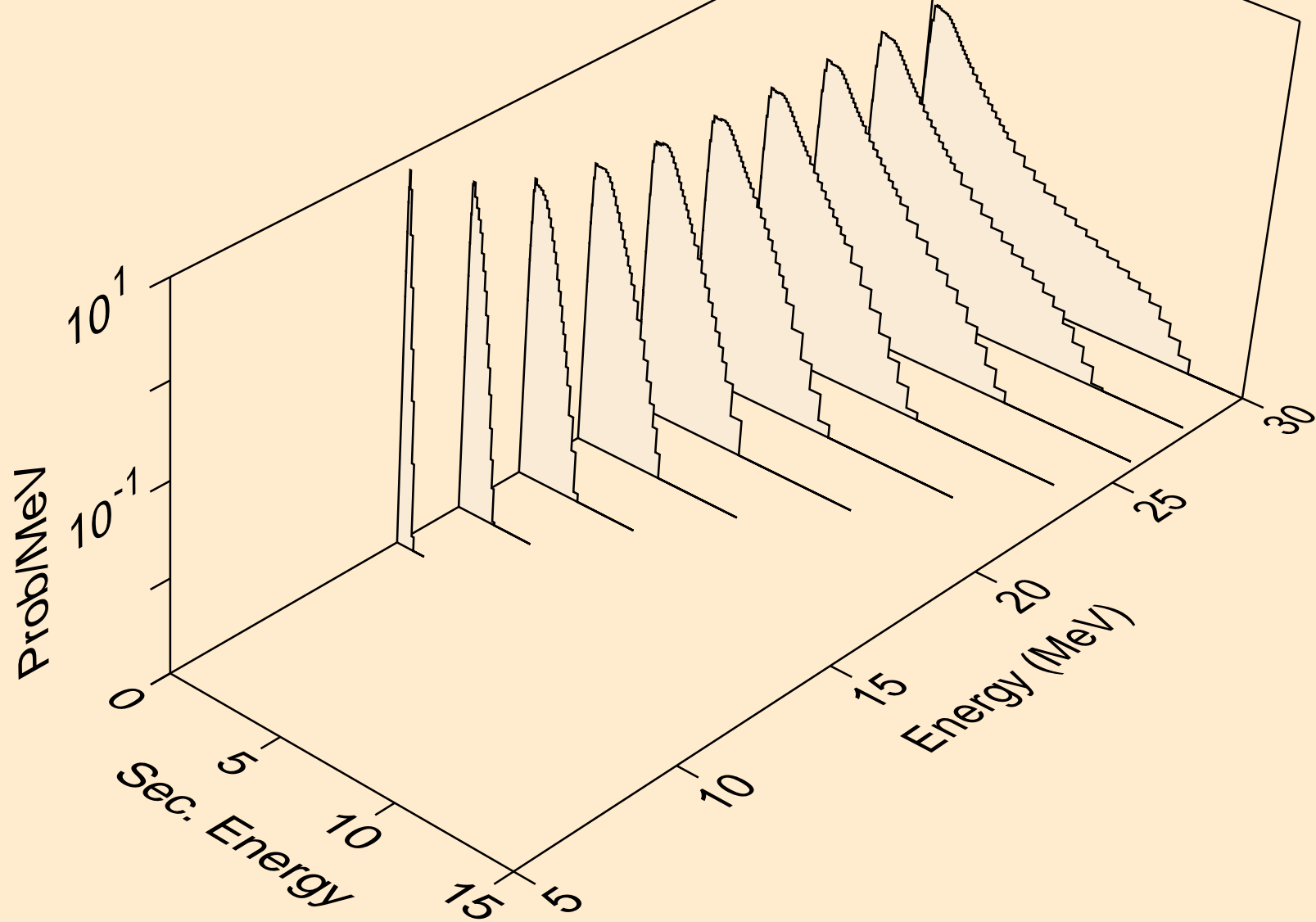

TM158 NEUTRON ACER TENDL-2024 LIBRARY; T=293.6K
Neutron emission for (n,3np)

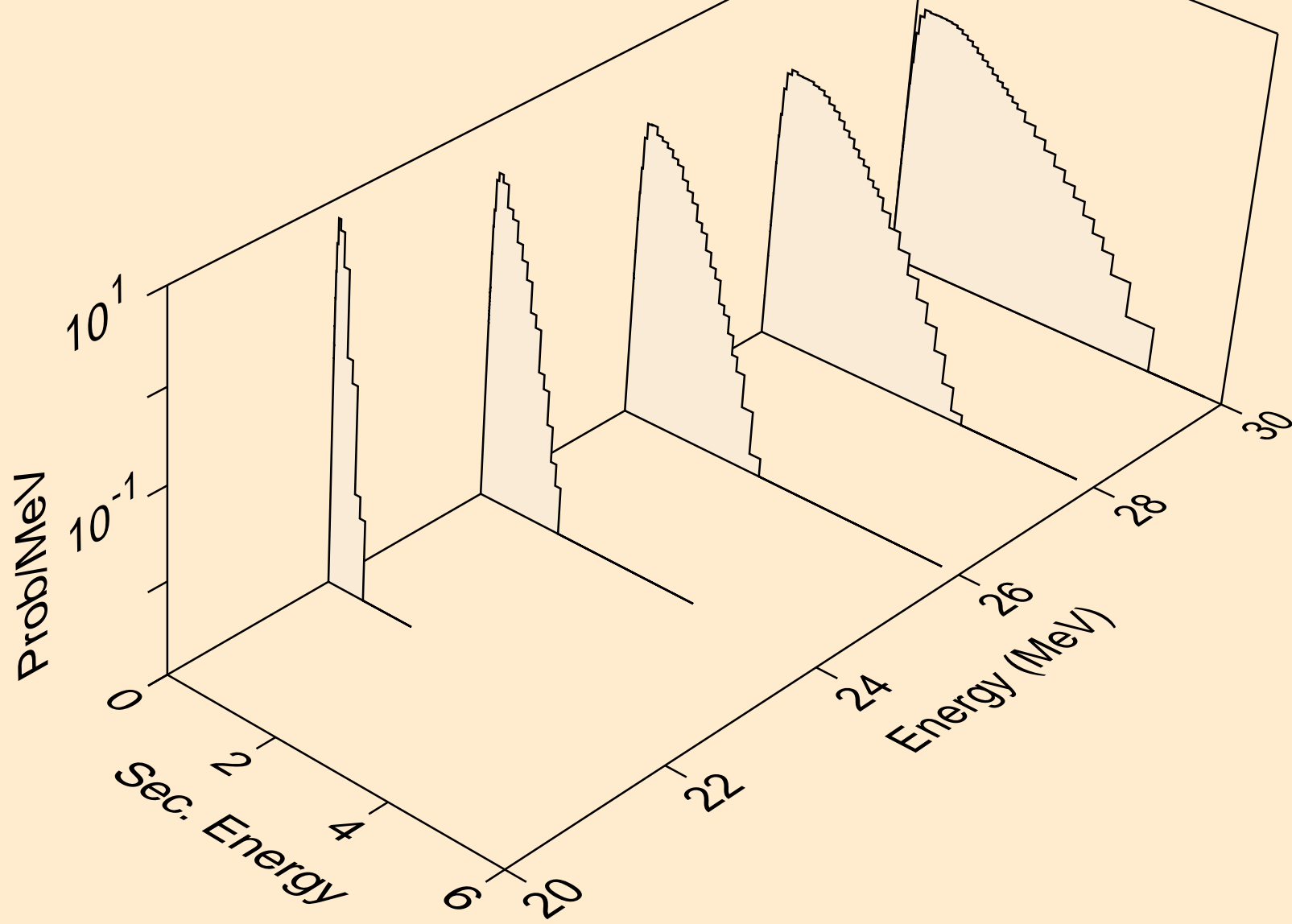

TM158 NEUTRON ACER TENDL-2024 LIBRARY; T=293.6K
Neutron emission for (n,n2p)

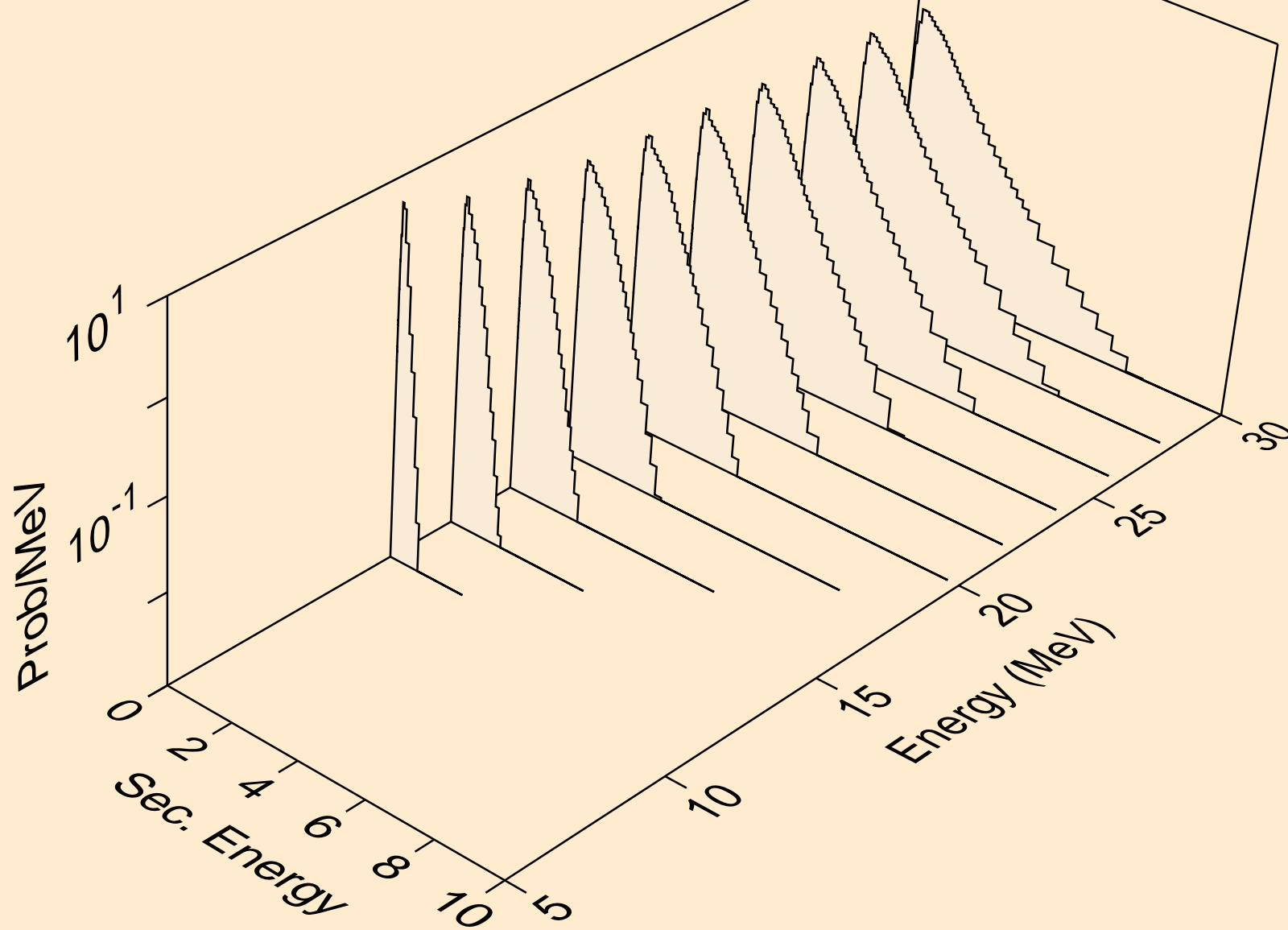

TM158 NEUTRON ACER TENDL-2024 LIBRARY; T=293.6K
Neutron emission for (n,npa)

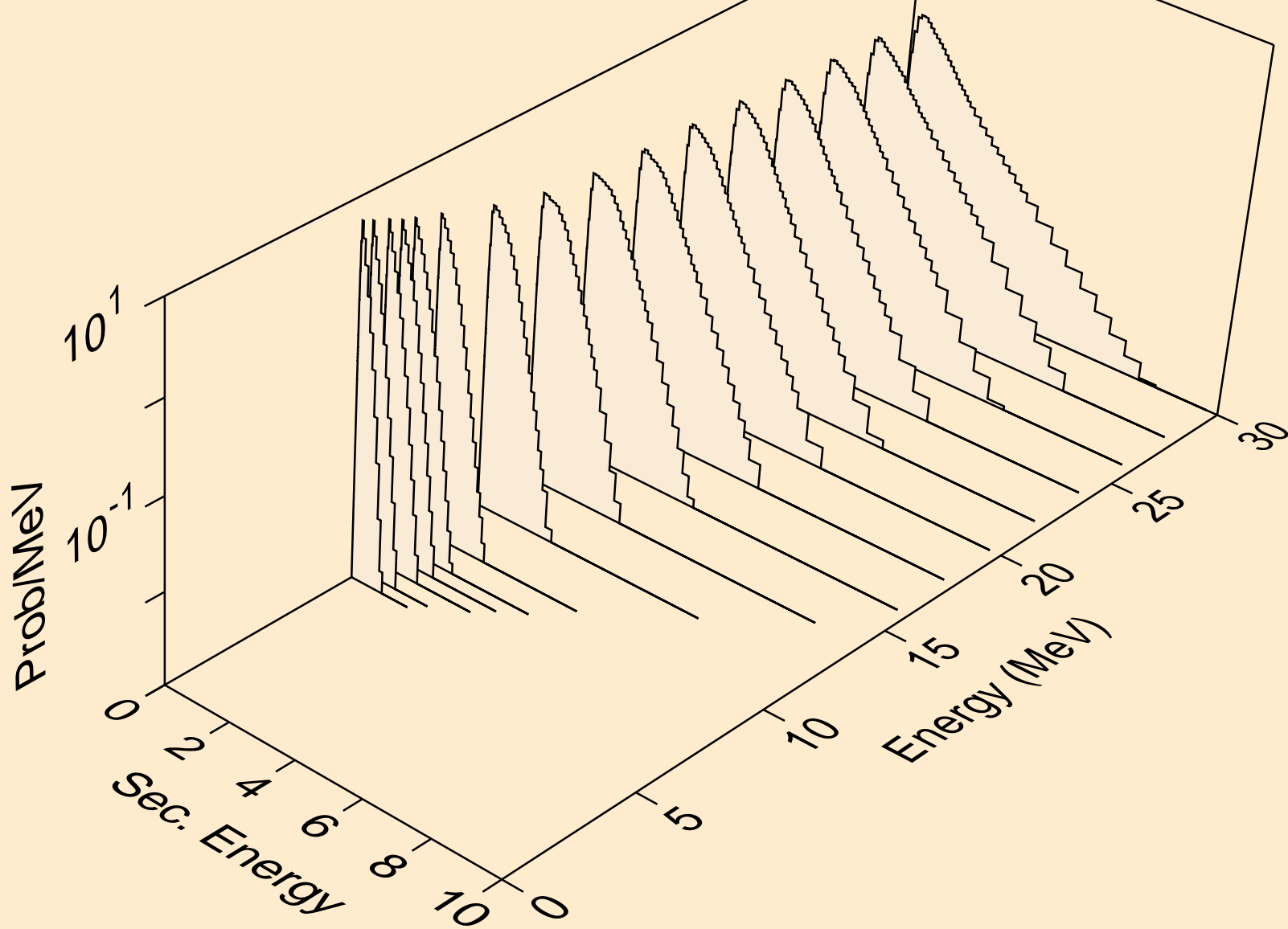

TM158 NEUTRON ACER TENDL-2024 LIBRARY; T=293.6K
Neutron emission for (n,n*c)

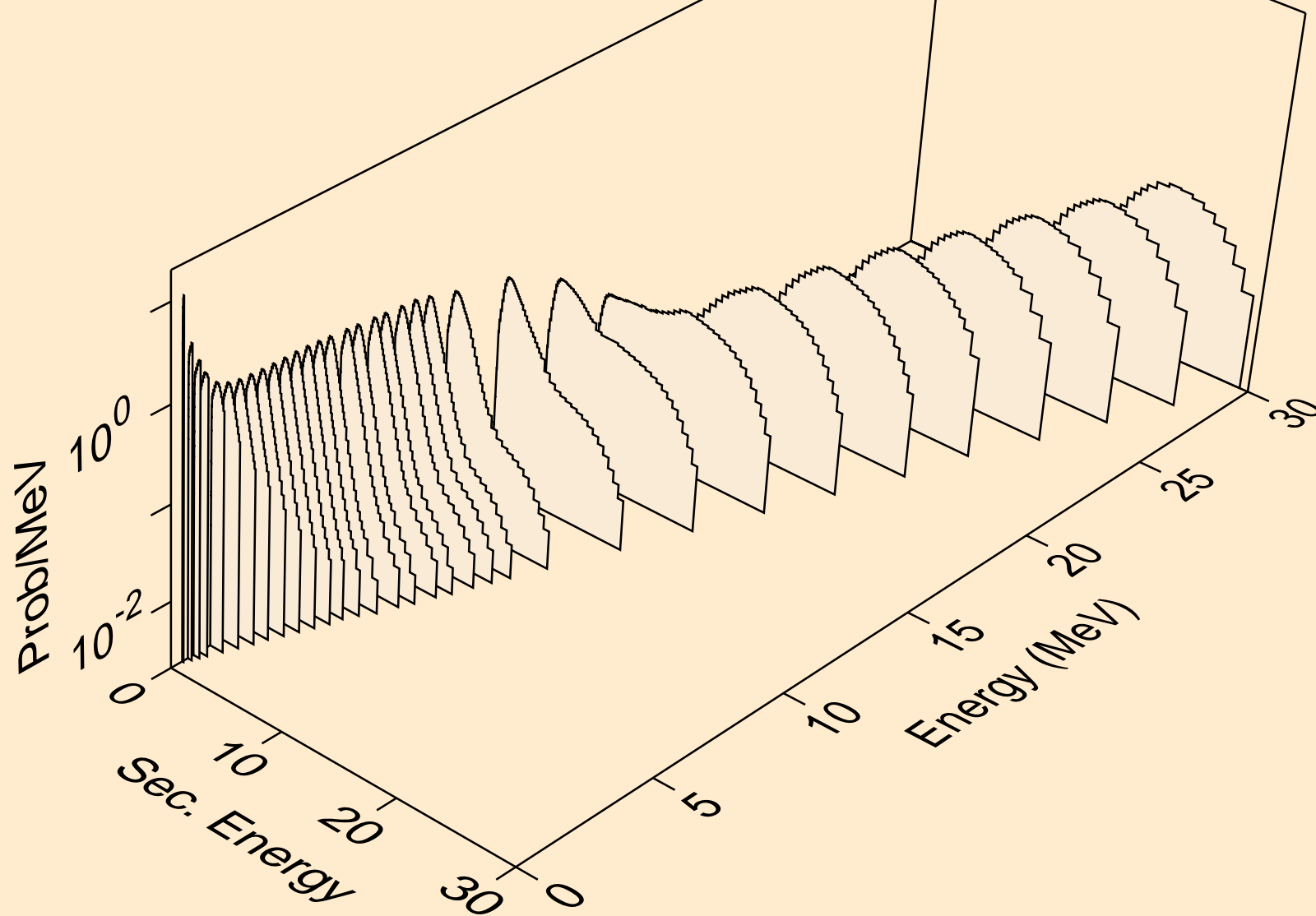

TM158 NEUTRON ACER TENDL-2024 LIBRARY; T=293.6K
Photon emission for (n,x)

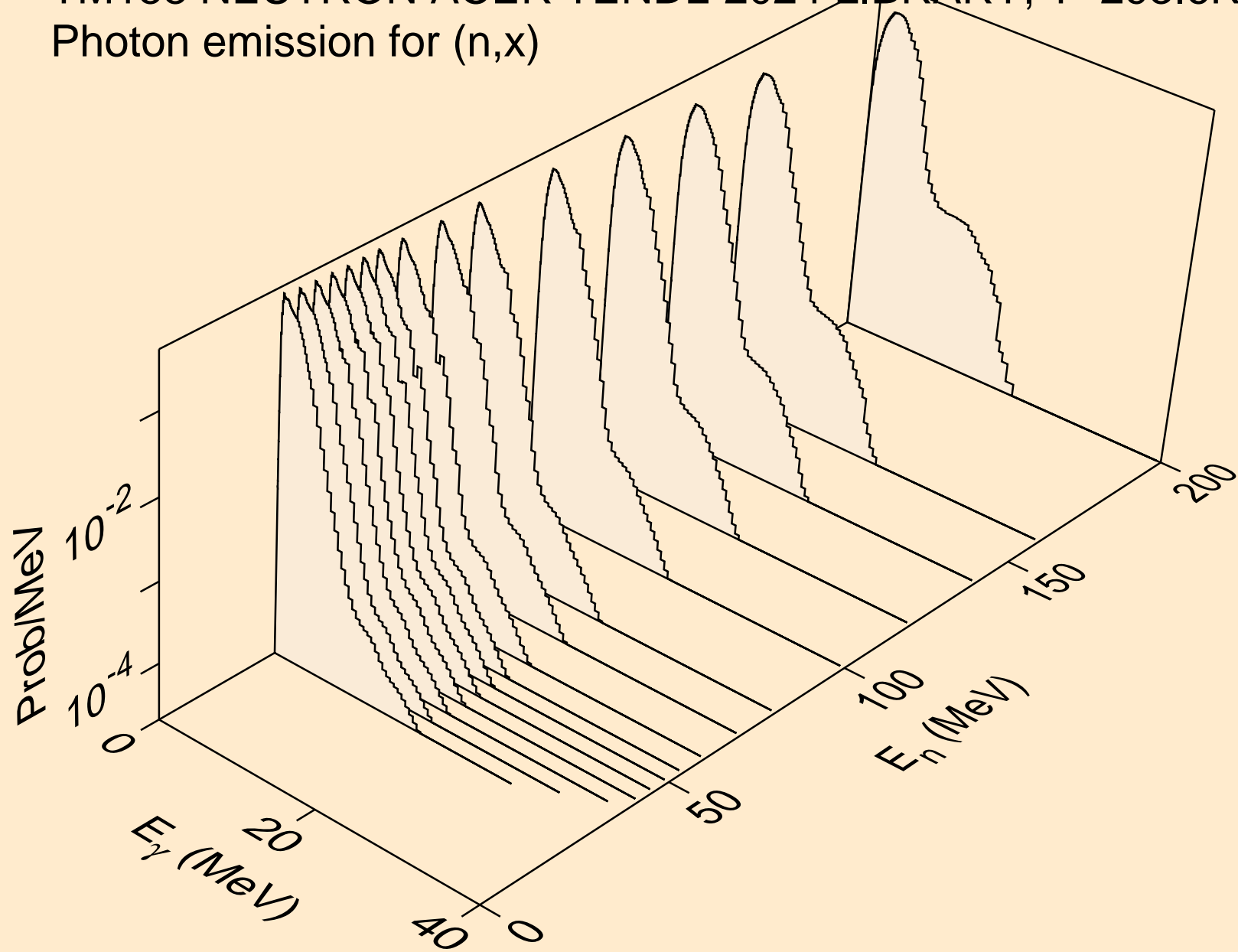

TM158 NEUTRON ACER TENDL-2024 LIBRARY; T=293.6K
Photon emission for (n,2nd)

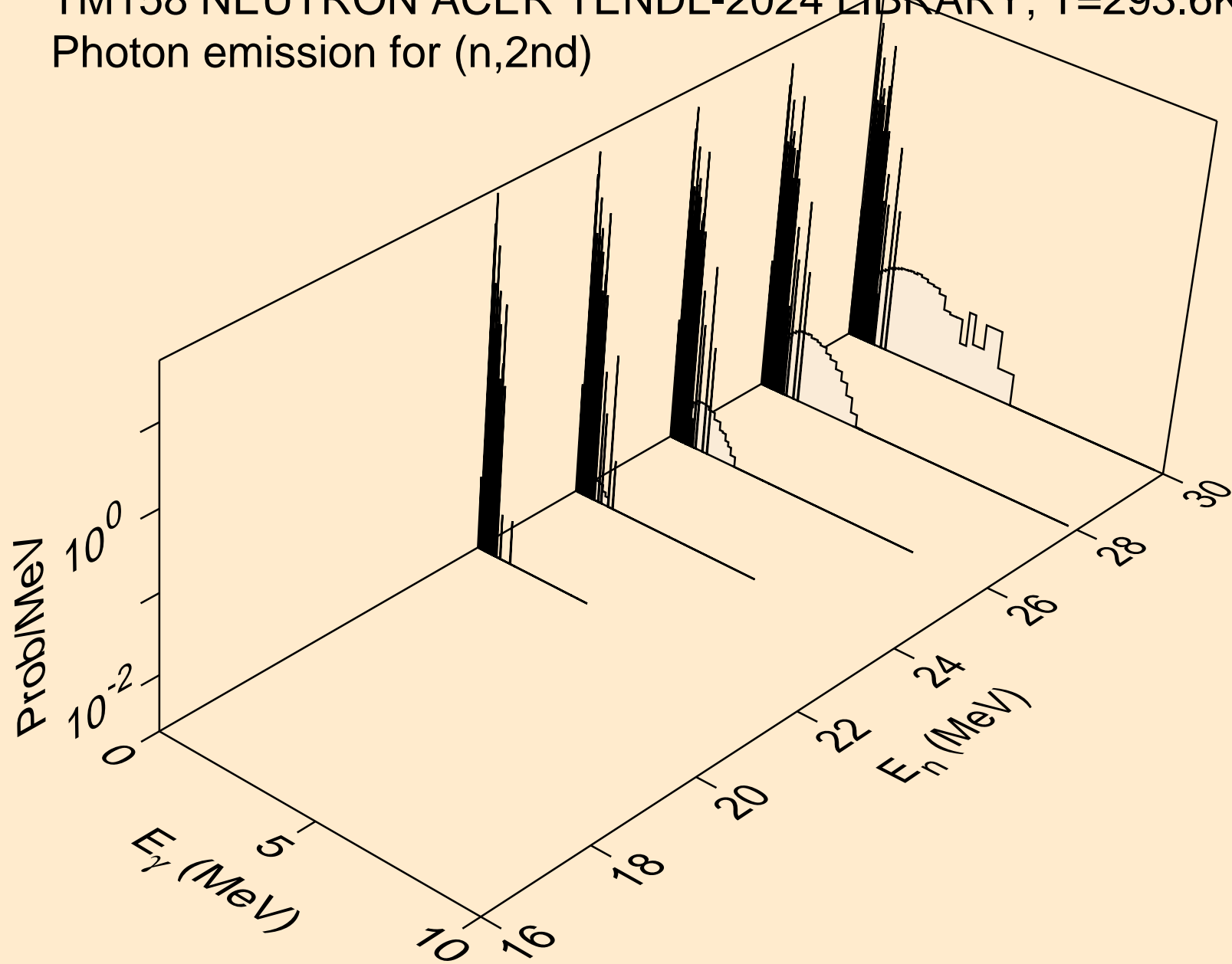

TM158 NEUTRON ACER TENDL-2024 LIBRARY; T=293.6K
Photon emission for (n,2n)

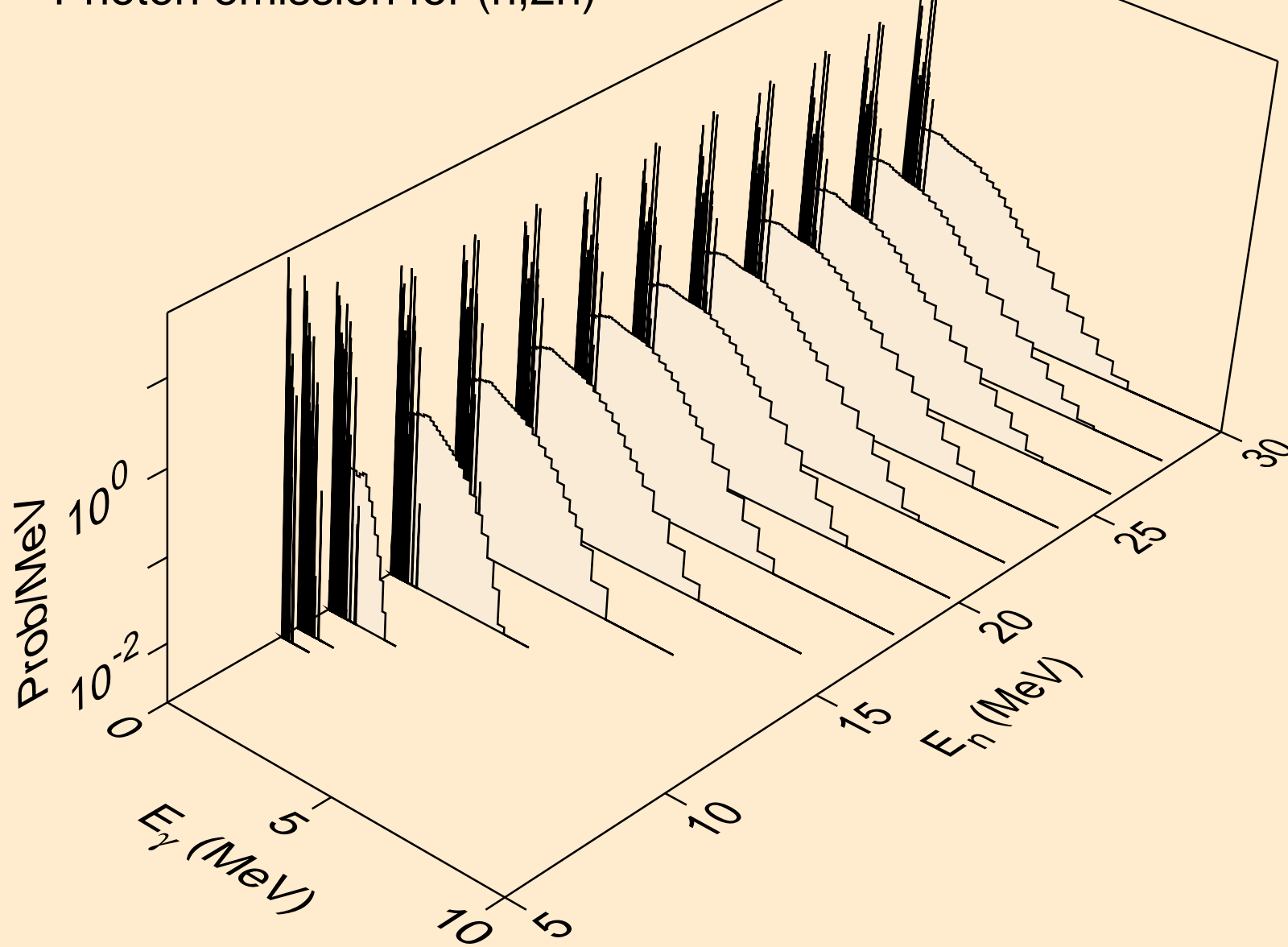

TM158 NEUTRON ACER TENDL-2024 LIBRARY; T=293.6K
Photon emission for (n,3n)

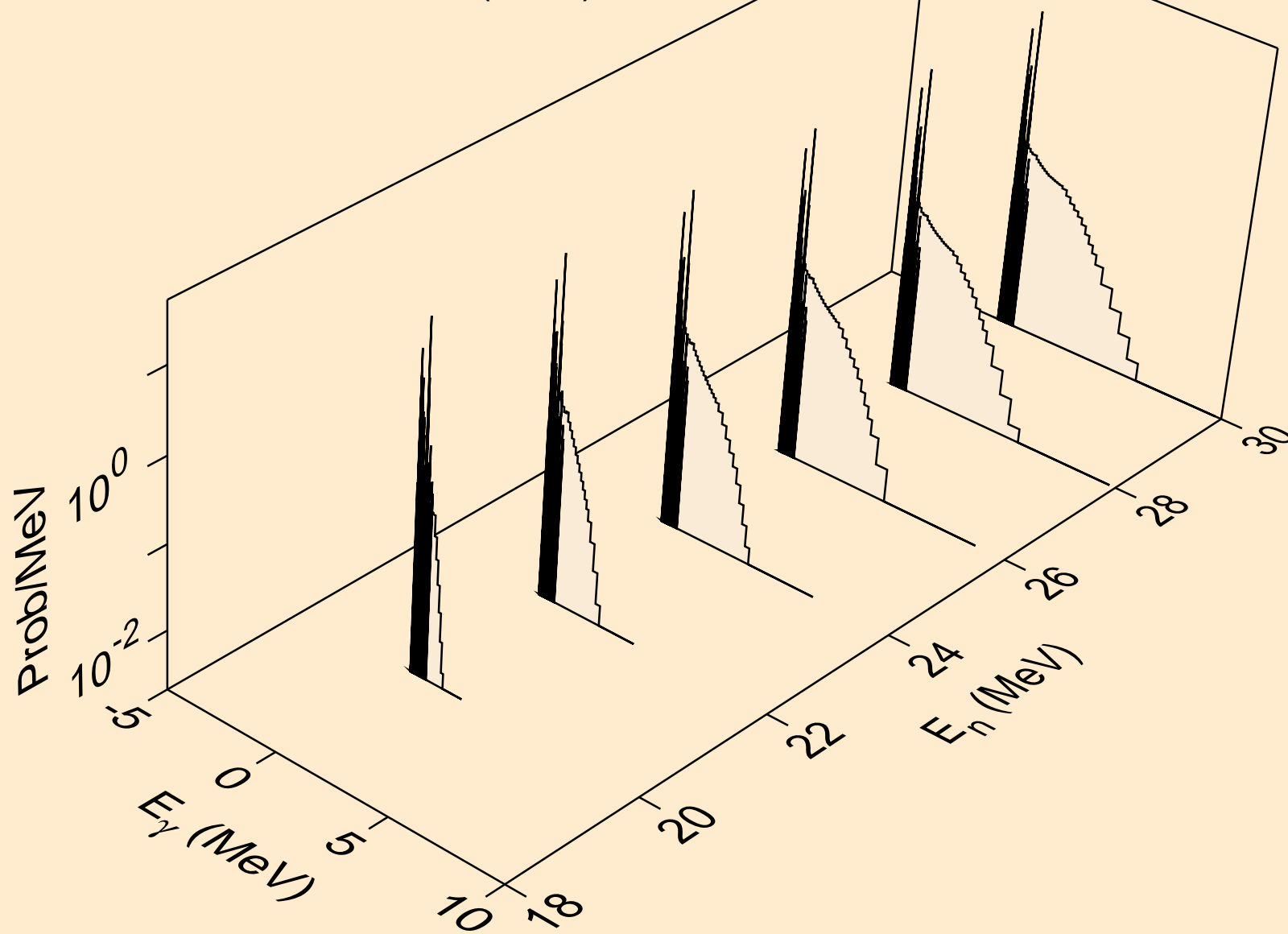

TM158 NEUTRON ACER TENDL-2024 LIBRARY; T=293.6K
Photon emission for (n,n*)a

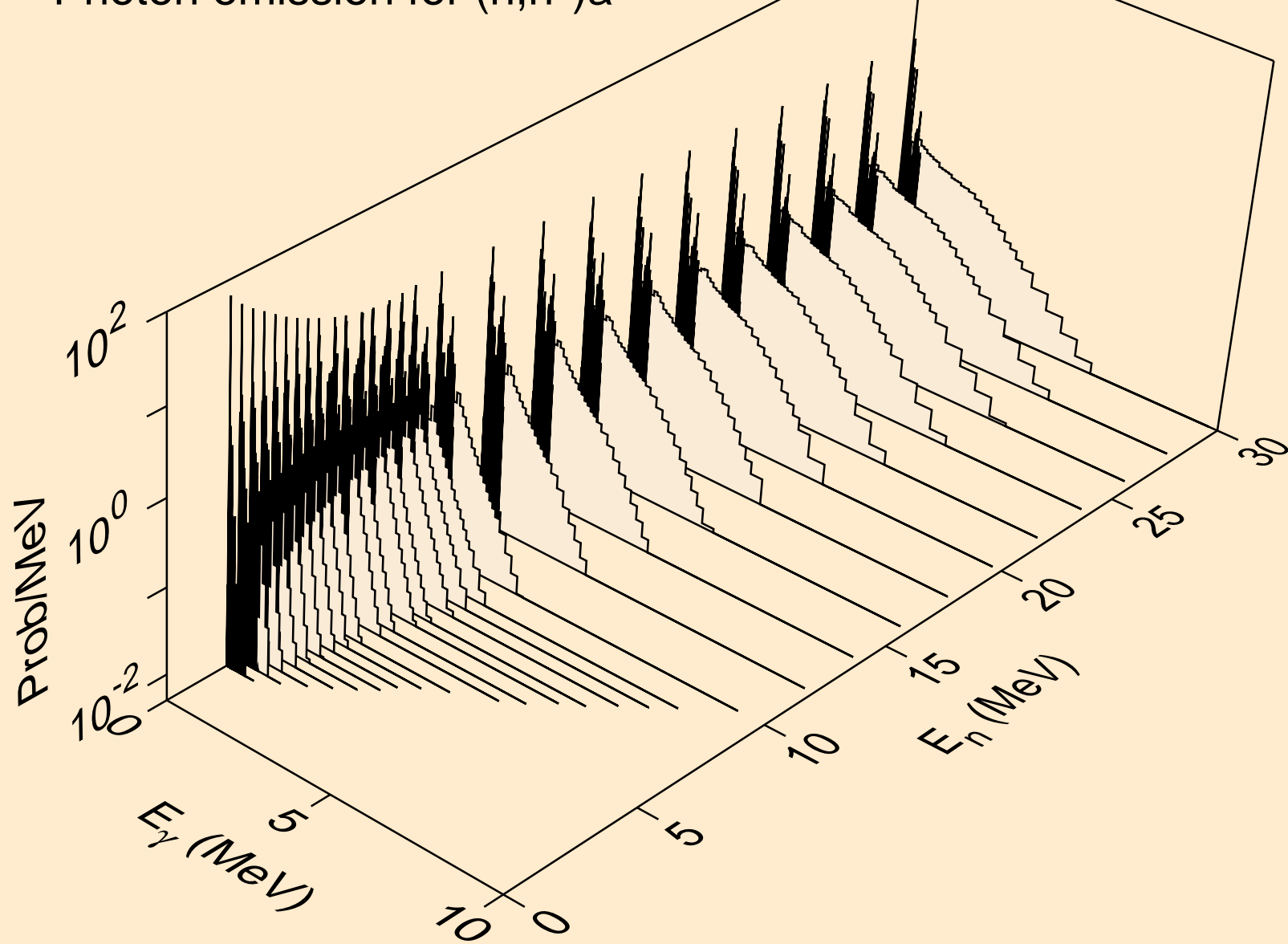

TM158 NEUTRON ACER TENDL-2024 LIBRARY; T=293.6K
Photon emission for (n,n*)3a

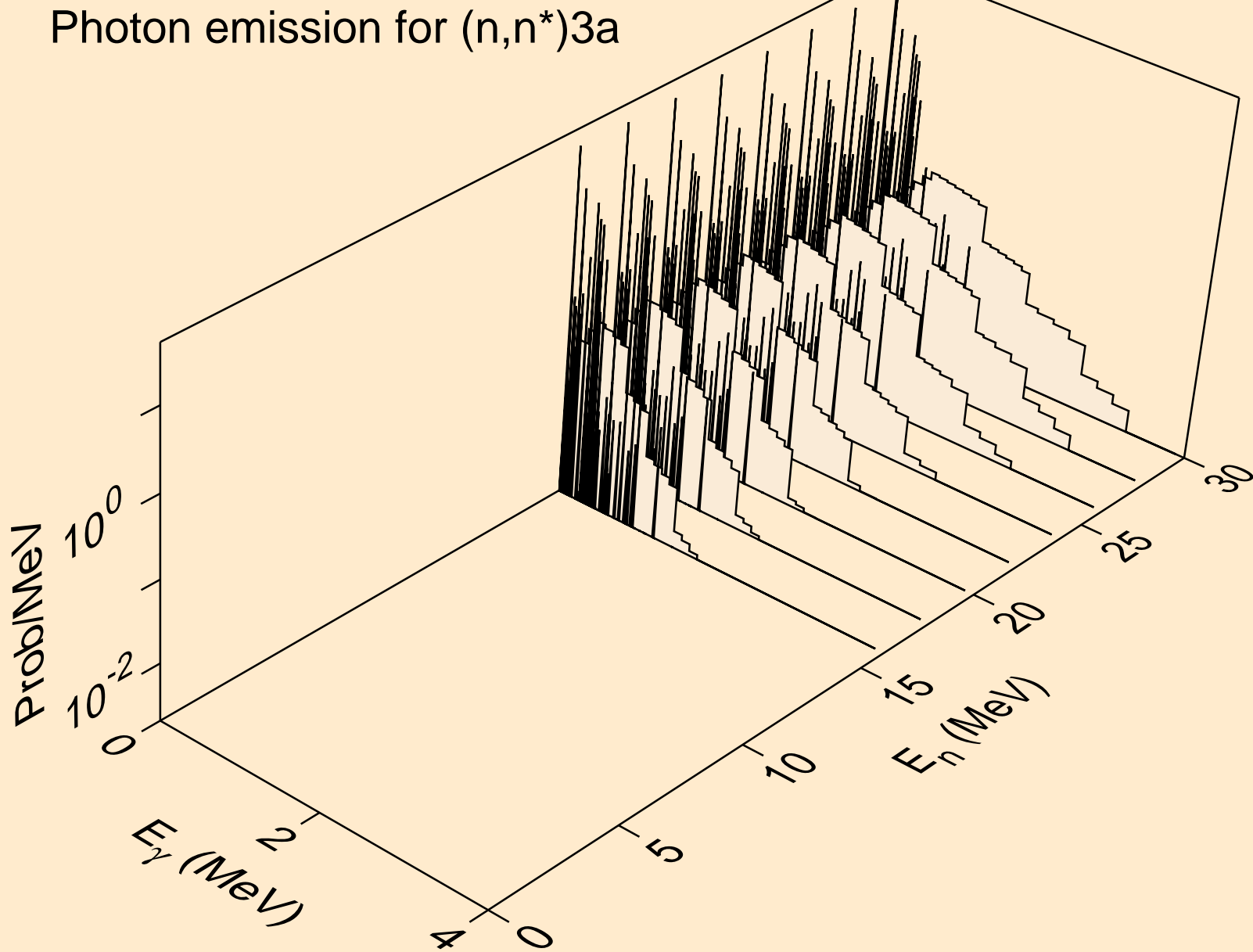

TM158 NEUTRON ACER TENDL-2024 LIBRARY; T=293.6K
Photon emission for (n,2n)a

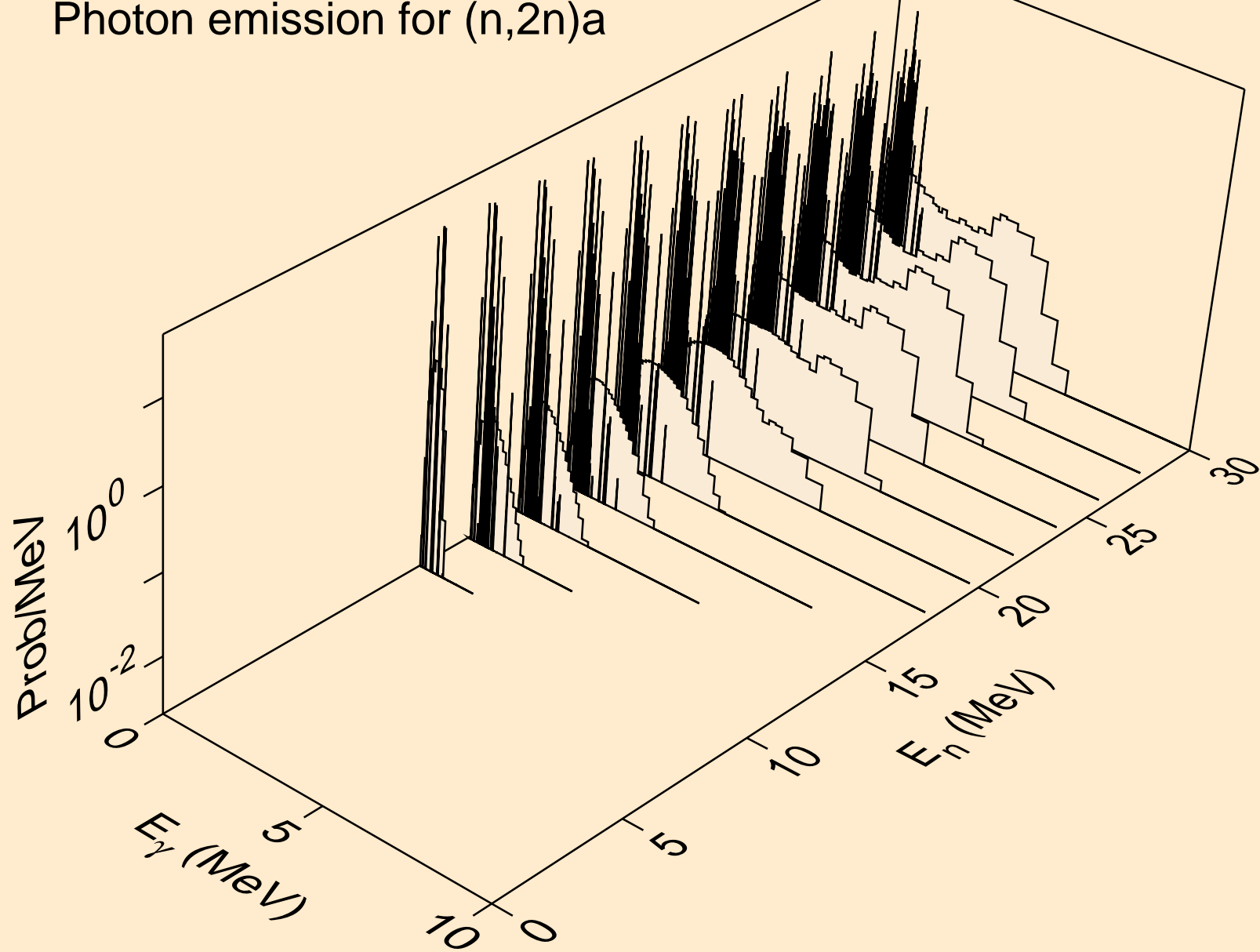

TM158 NEUTRON ACER TENDL-2024 LIBRARY; T=293.6K
Photon emission for (n,3n)a

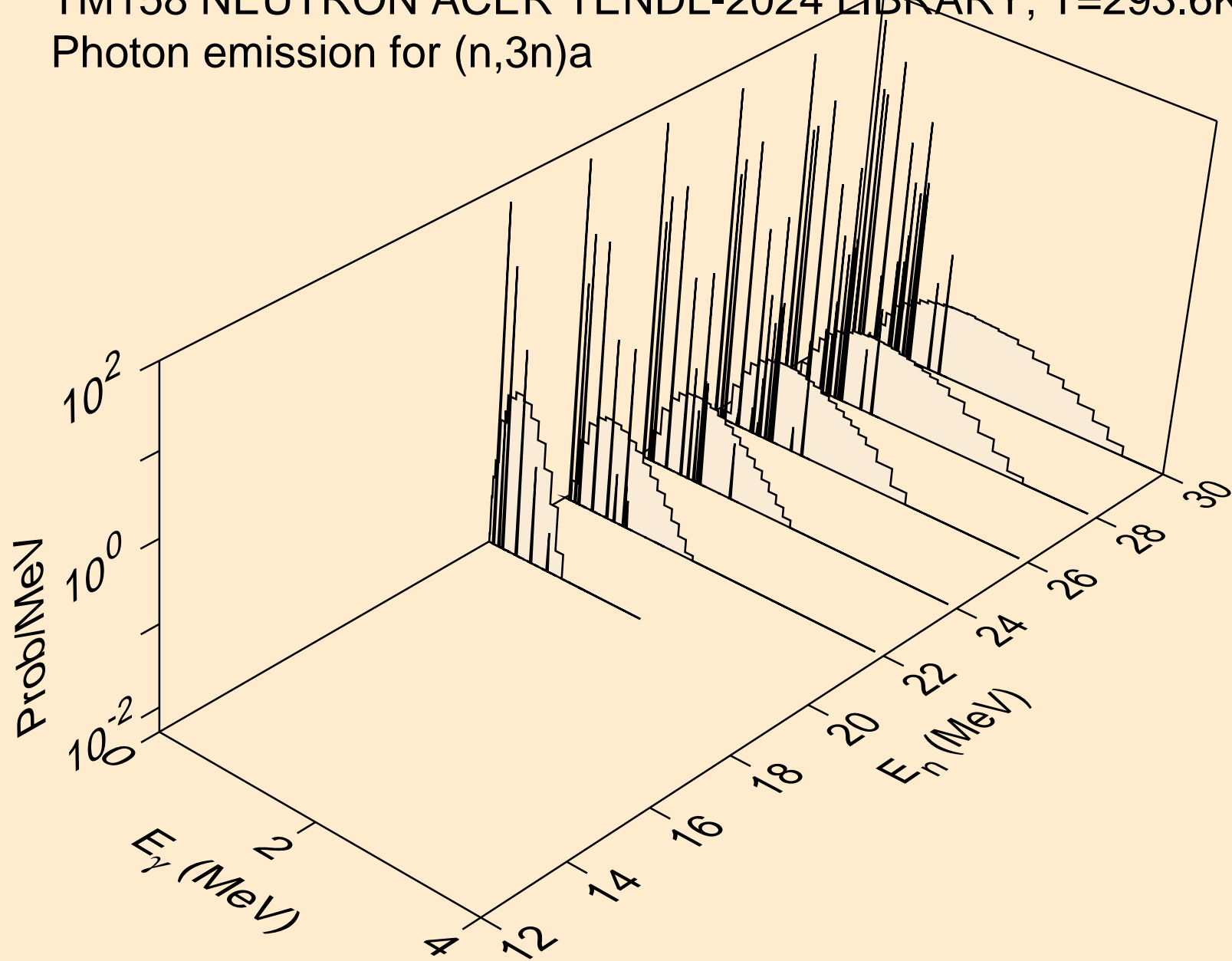

TM158 NEUTRON ACER TENDL-2024 LIBRARY; T=293.6K
Photon emission for (n,n*)p

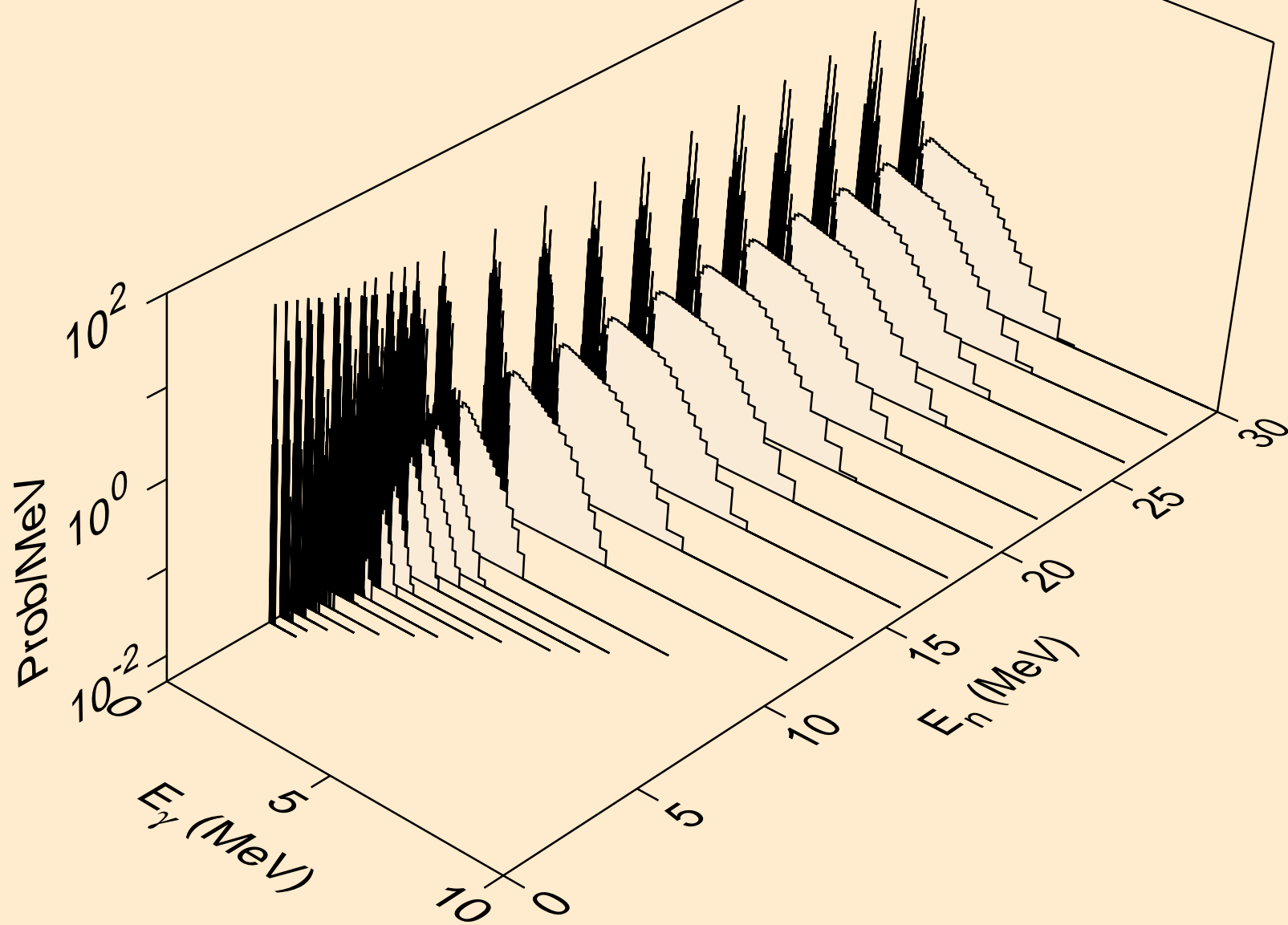

TM158 NEUTRON ACER TENDL-2024 LIBRARY; T=293.6K
Photon emission for (n,n*)2a

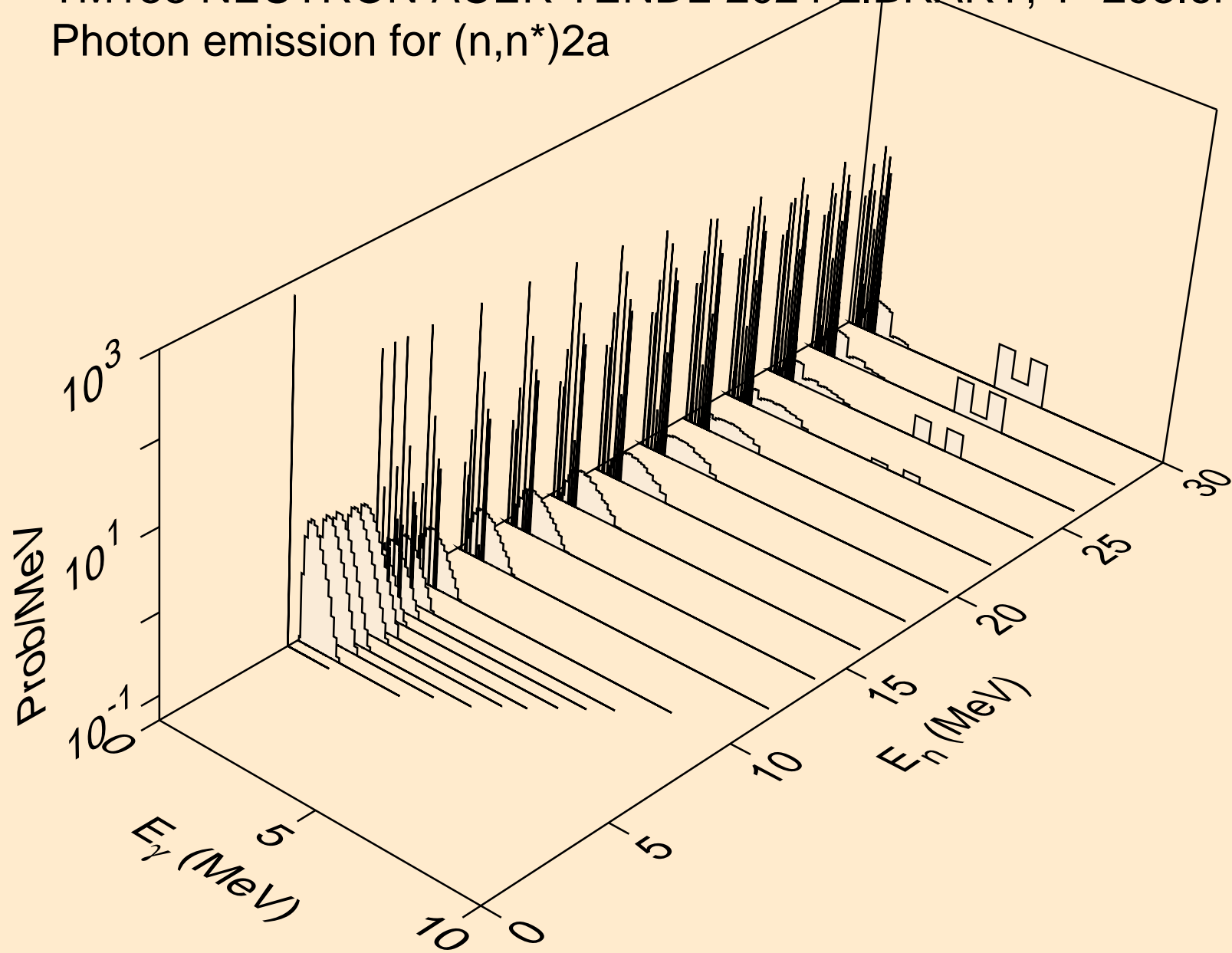

TM158 NEUTRON ACER TENDL-2024 LIBRARY; T=293.6K
Photon emission for (n,2n)2a

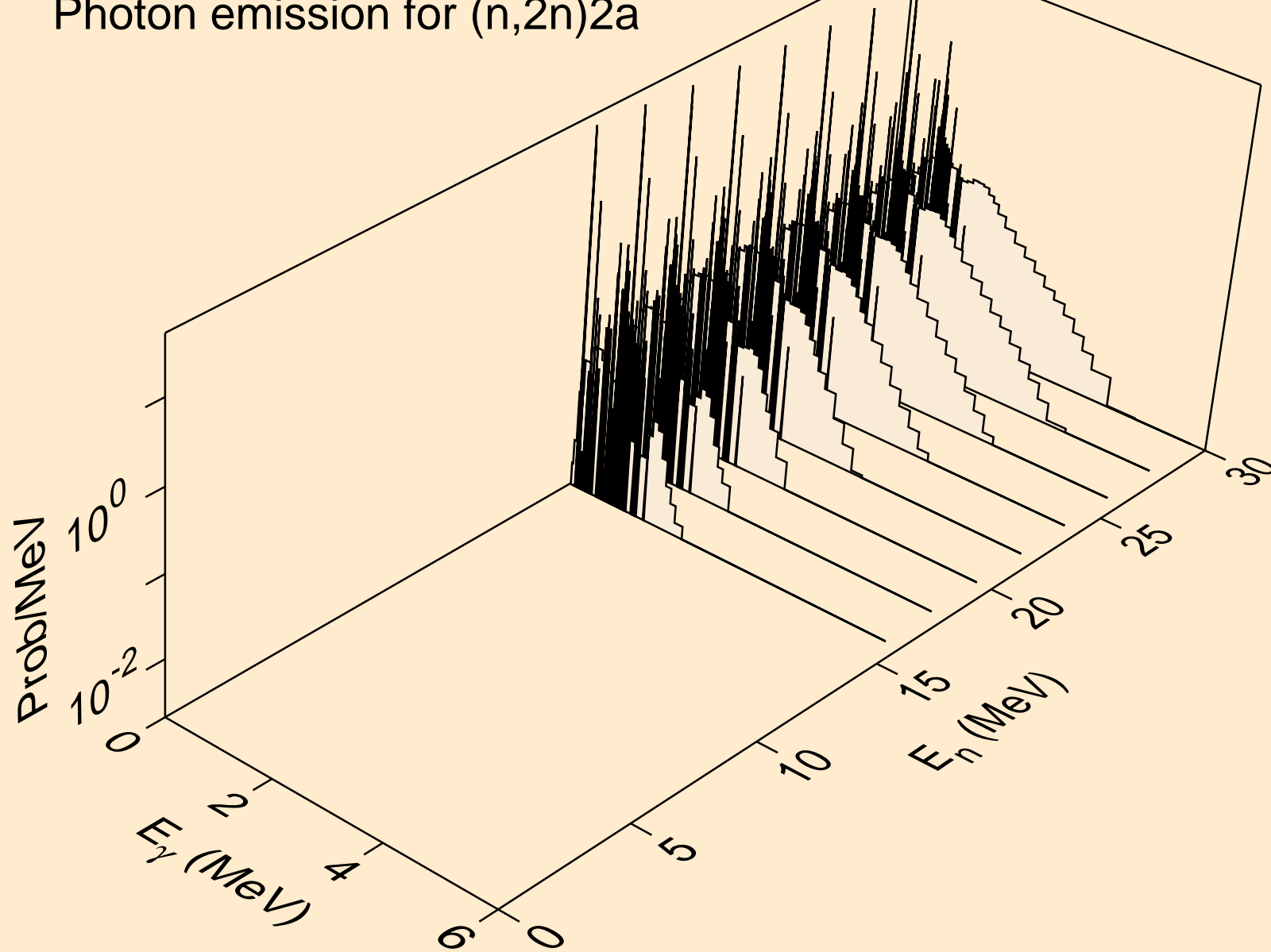

TM158 NEUTRON ACER TENDL-2024 LIBRARY; T=293.6K
Photon emission for (n,n*)d

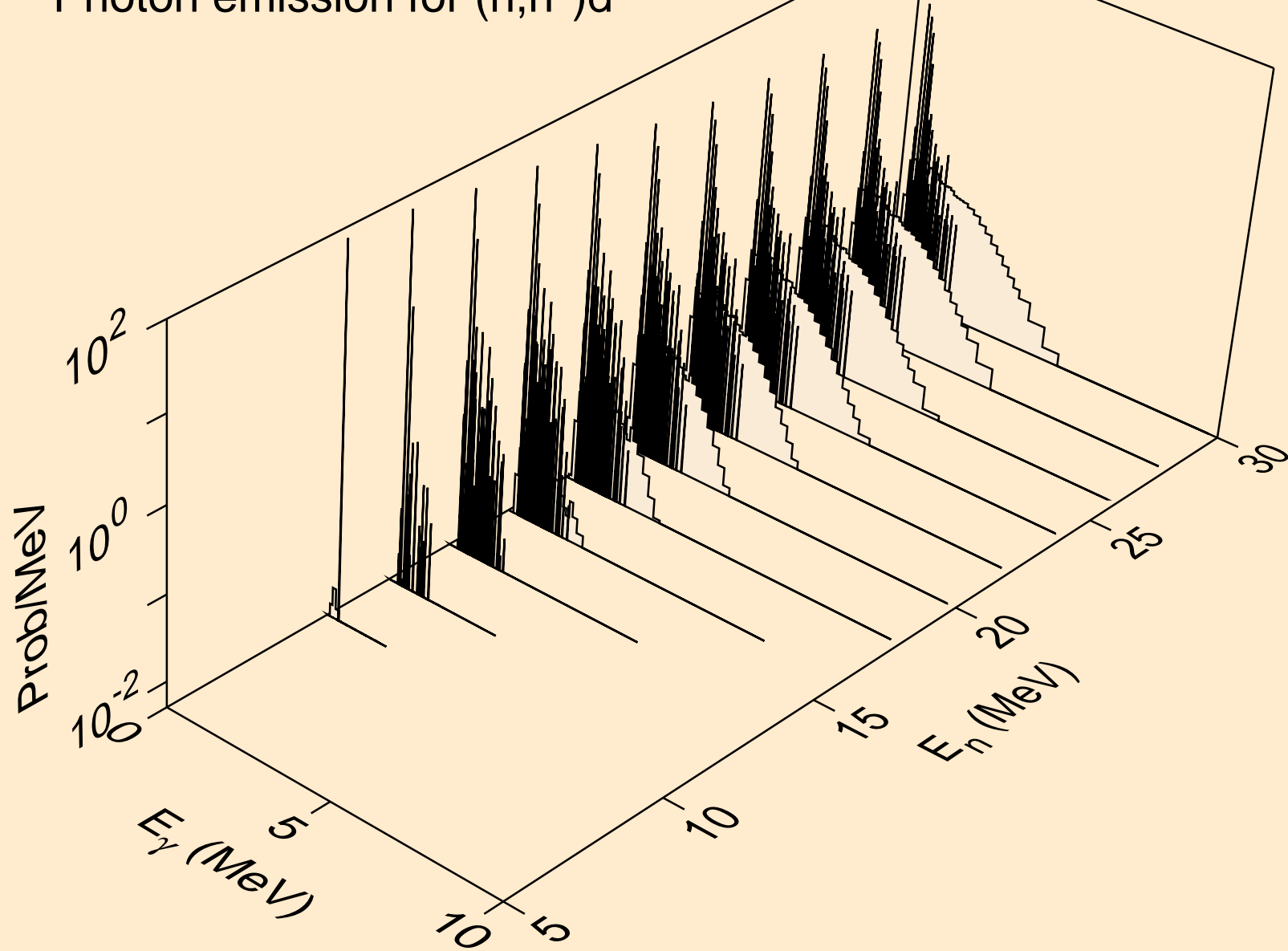

TM158 NEUTRON ACER TENDL-2024 LIBRARY; T=293.6K
Photon emission for (n,n*)t

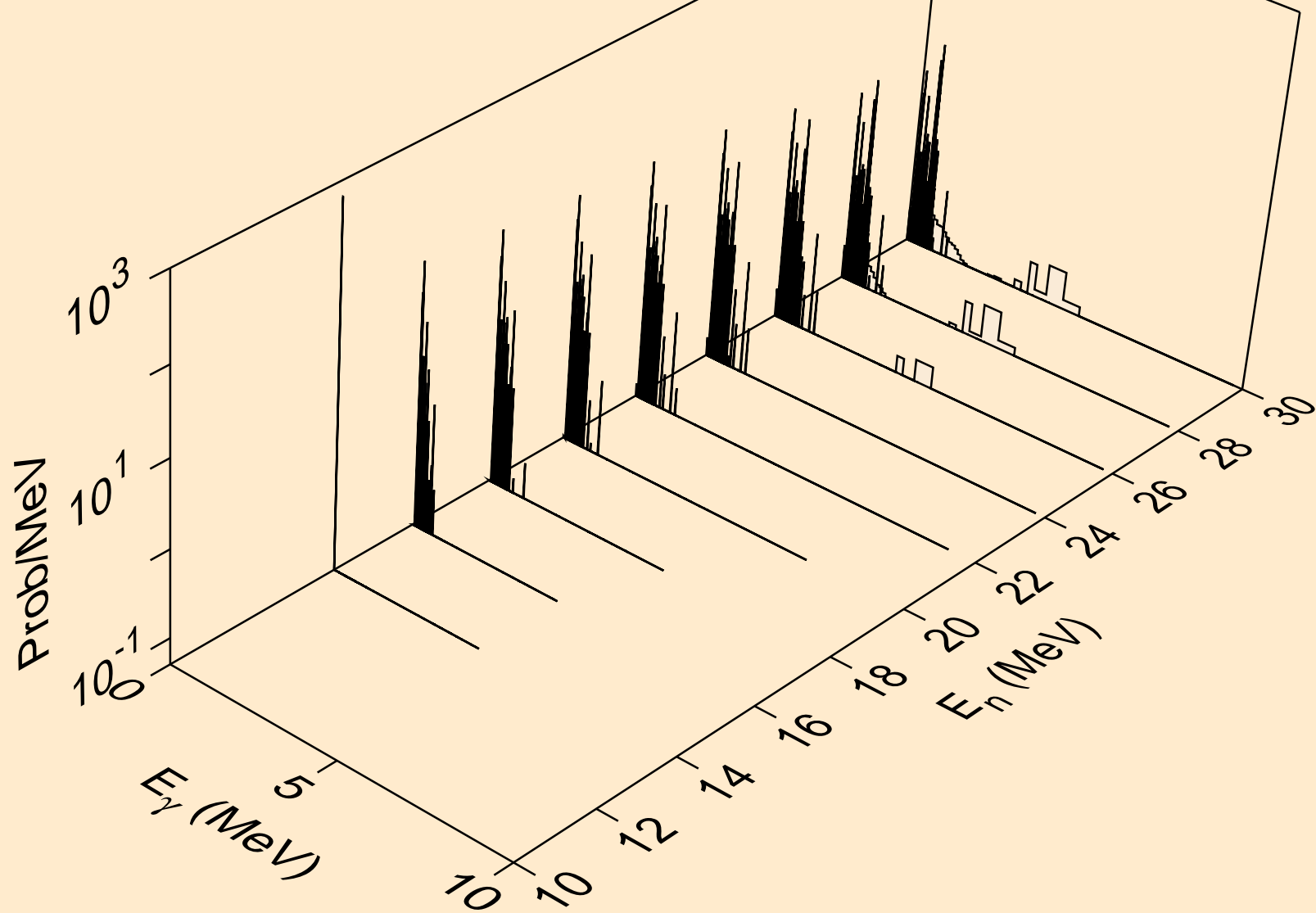

TM158 NEUTRON ACER TENDL-2024 LIBRARY; T=293.6K
Photon emission for (n,n*)he3

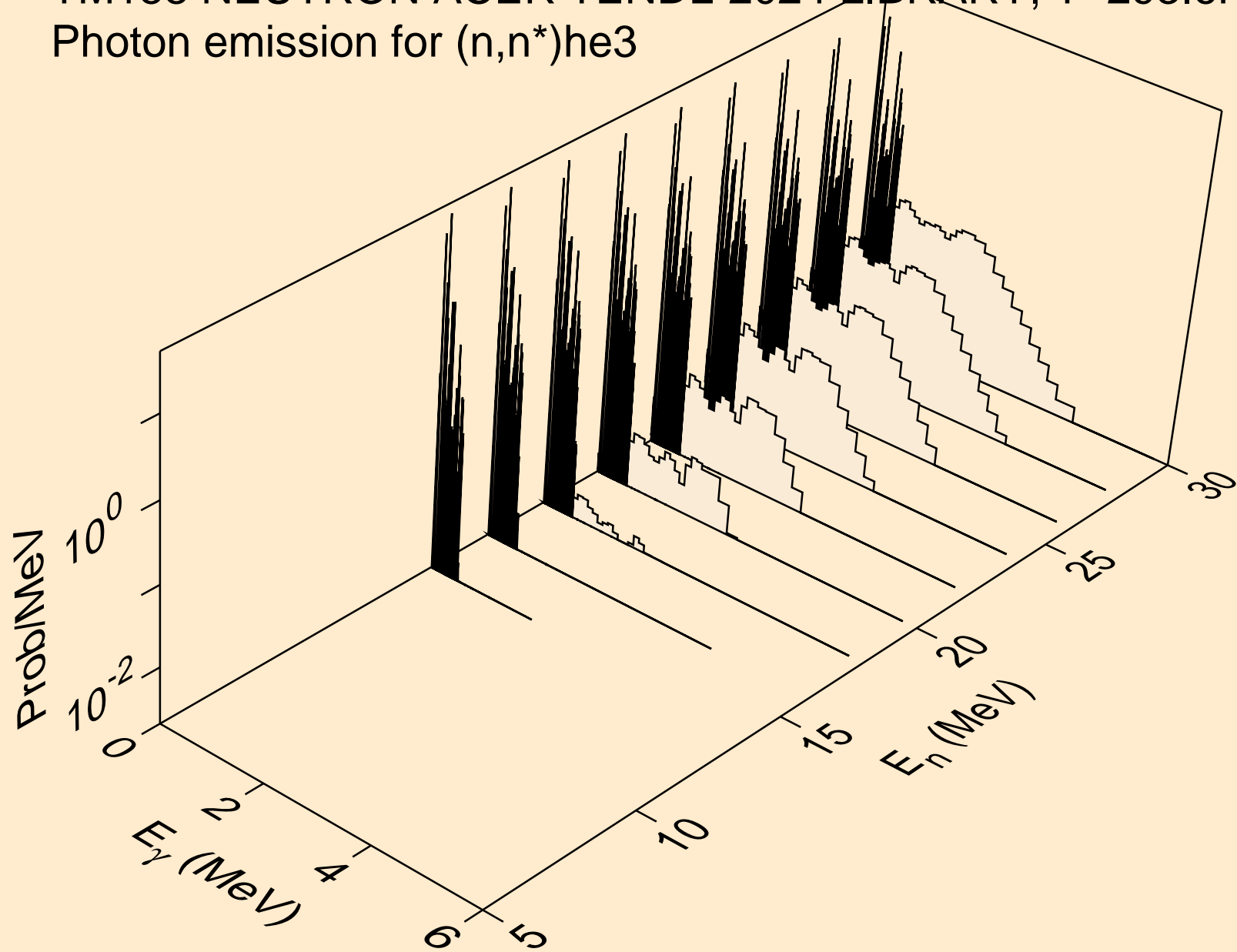

TM158 NEUTRON ACER TENDL-2024 LIBRARY; T=293.6K
Photon emission for (n,4n)

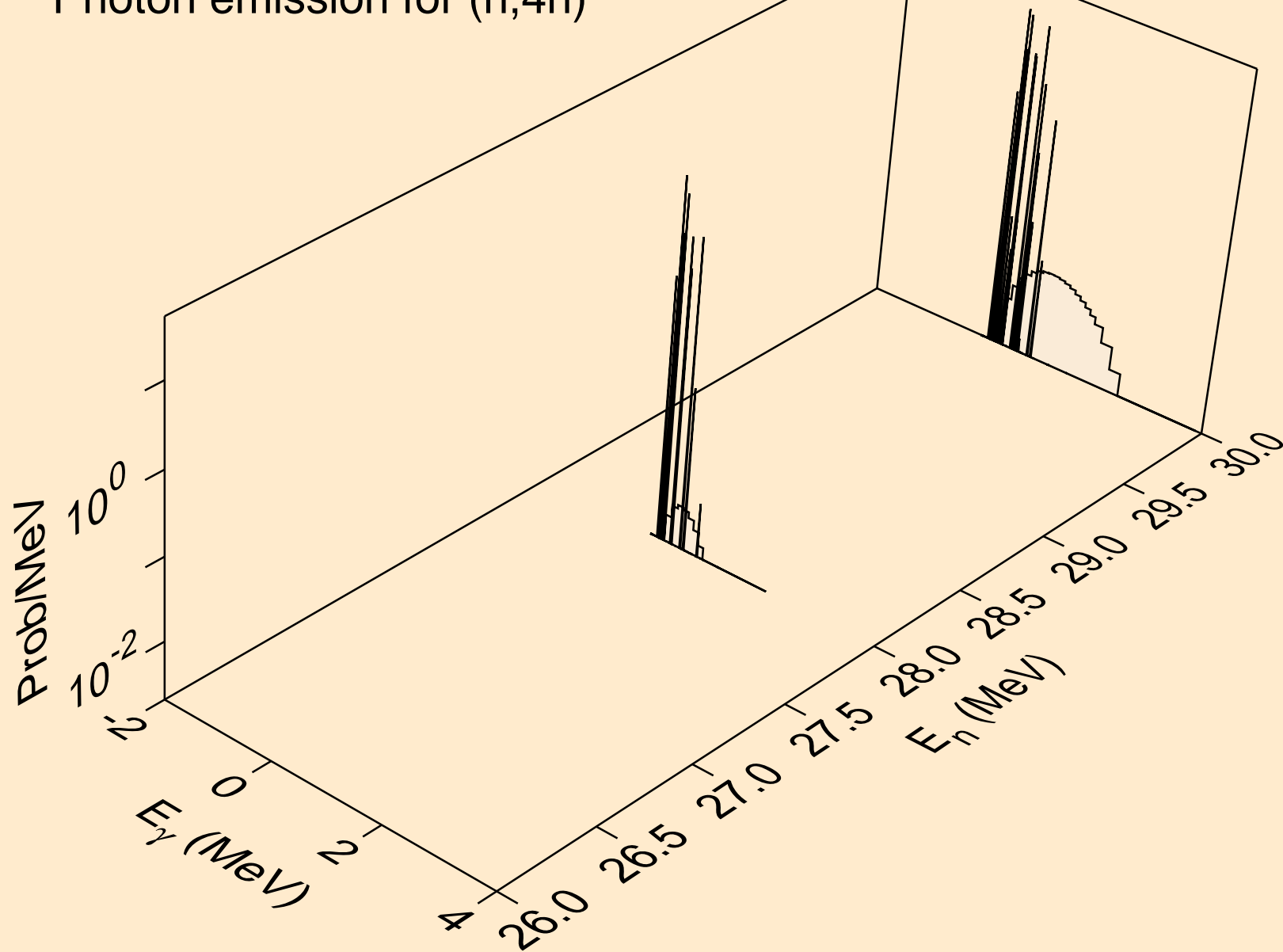

TM158 NEUTRON ACER TENDL-2024 LIBRARY; T=293.6K
Photon emission for (n,2np)

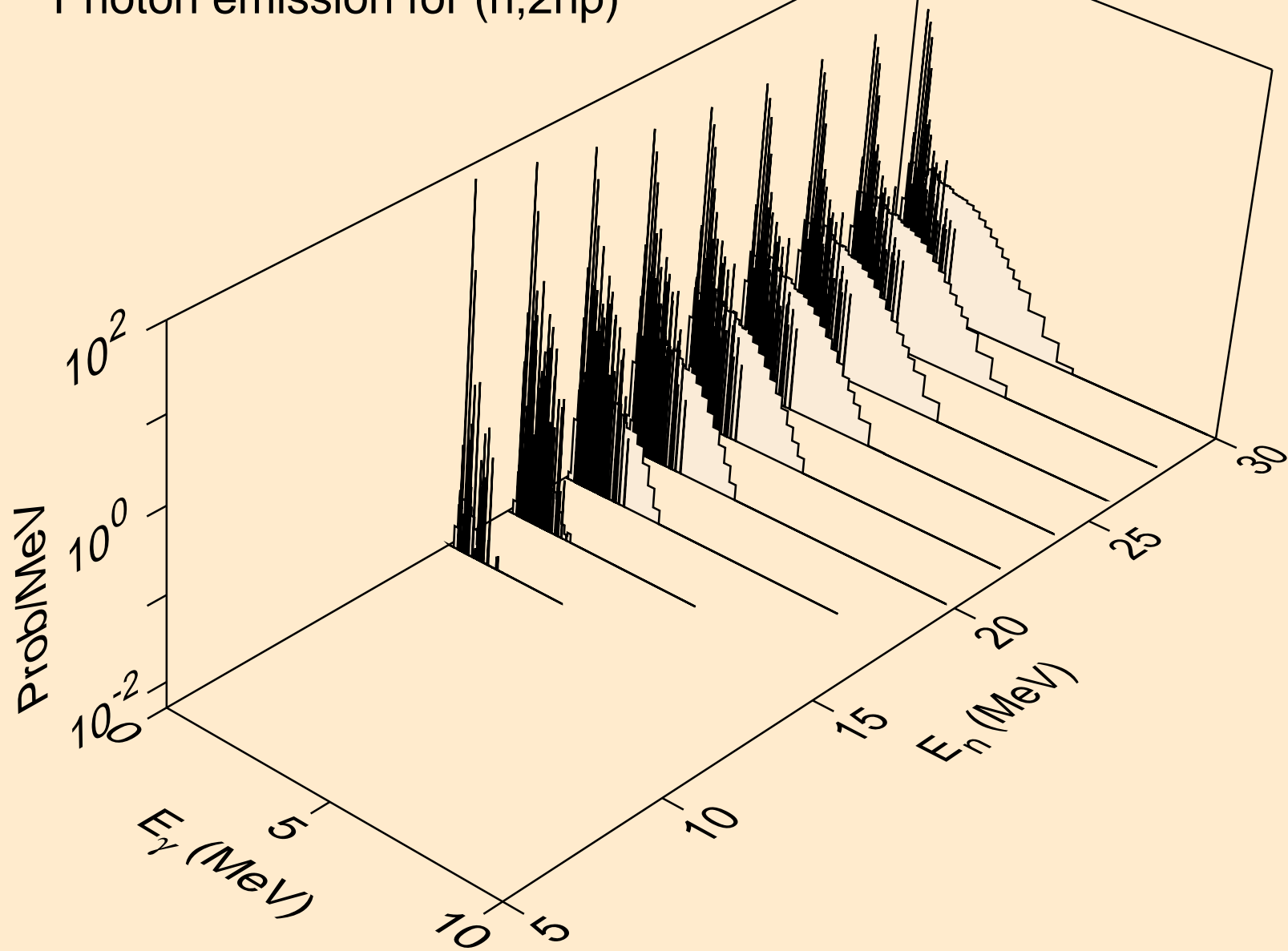

TM158 NEUTRON ACER TENDL-2024 LIBRARY; T=293.6K
Photon emission for (n,3np)

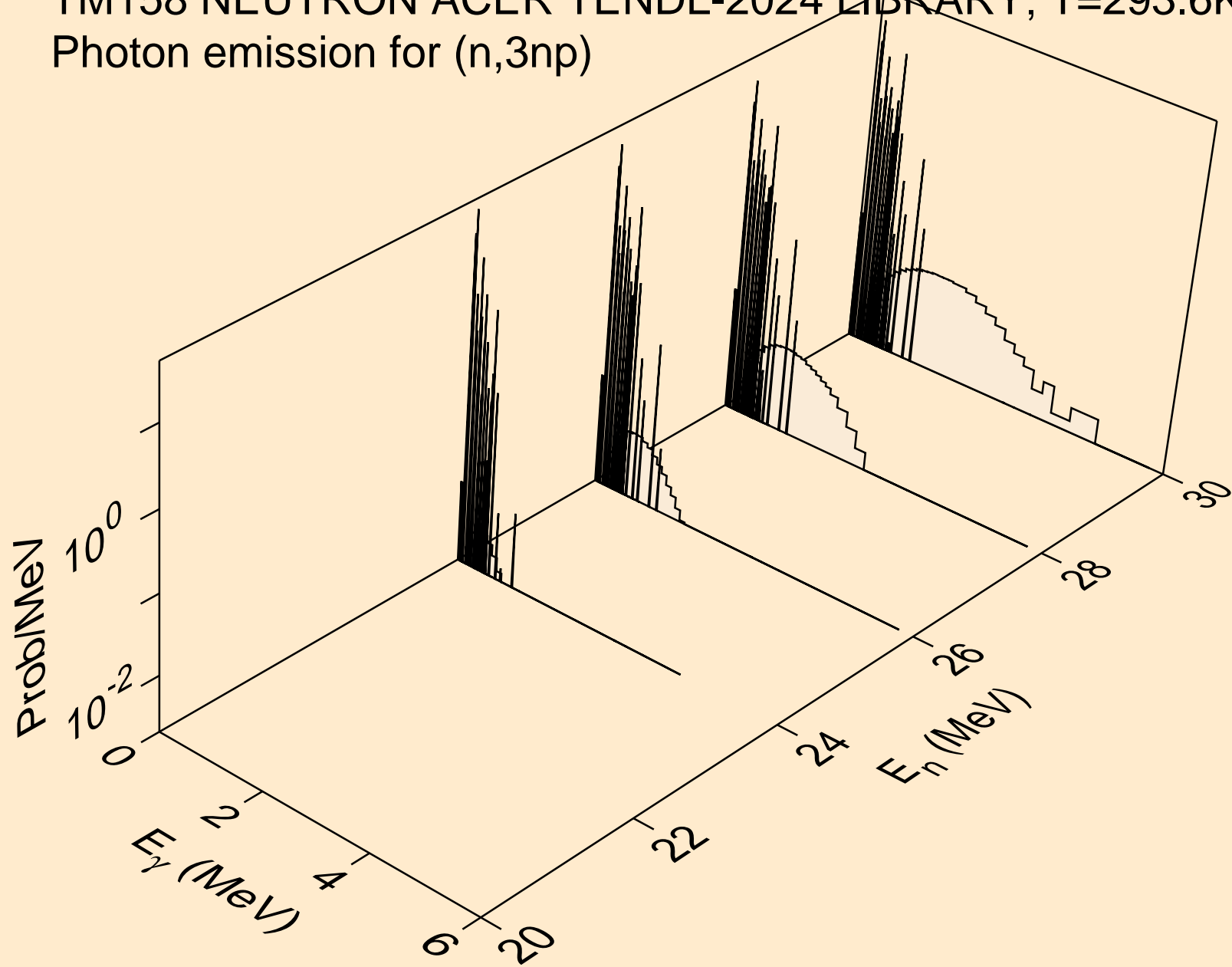

TM158 NEUTRON ACER TENDL-2024 LIBRARY; T=293.6K
Photon emission for (n,n2p)

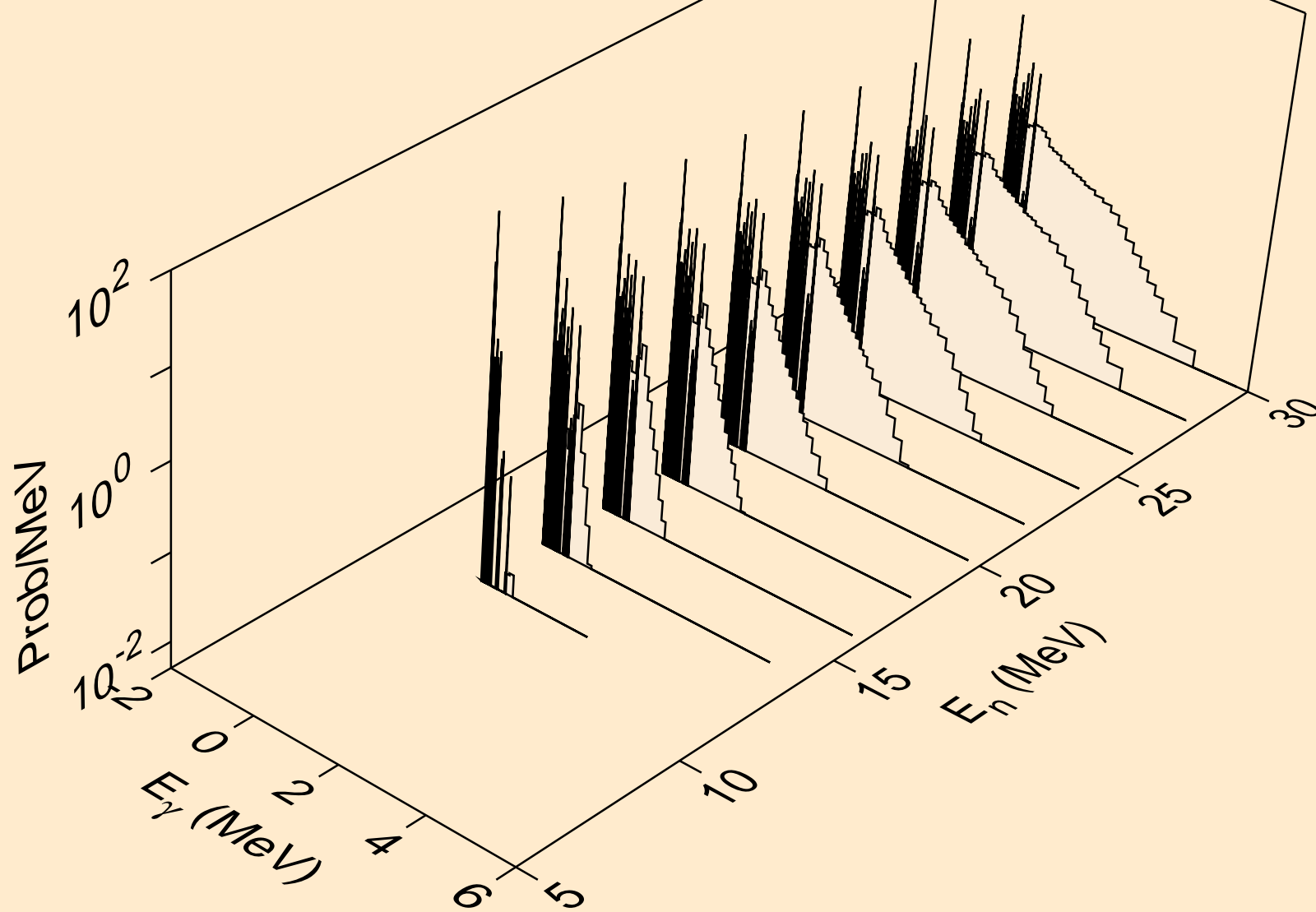

TM158 NEUTRON ACER TENDL-2024 LIBRARY; T=293.6K
Photon emission for (n,npa)

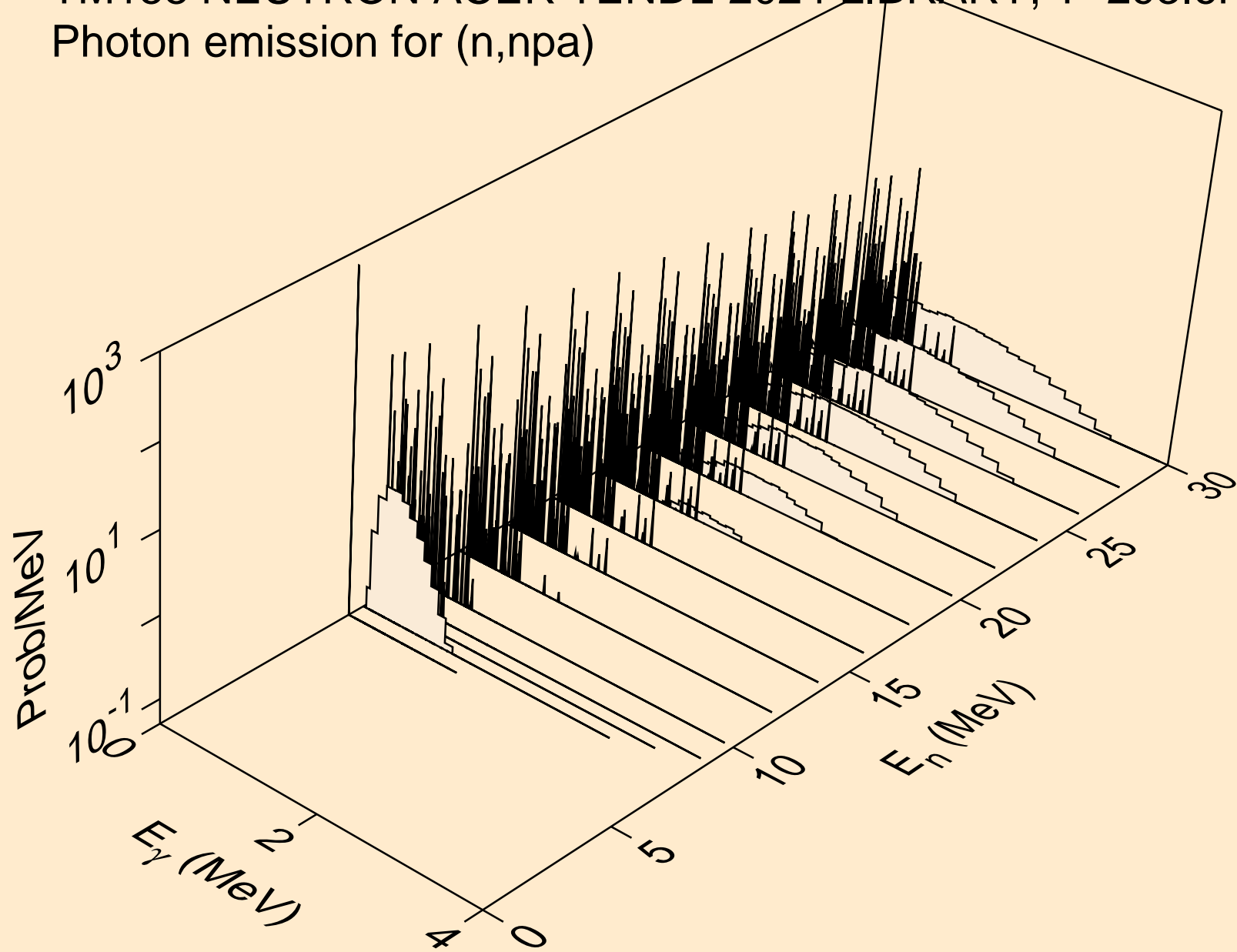

TM158 NEUTRON ACER TENDL-2024 LIBRARY; T=293.6K
Photon emission for (n,n*c)

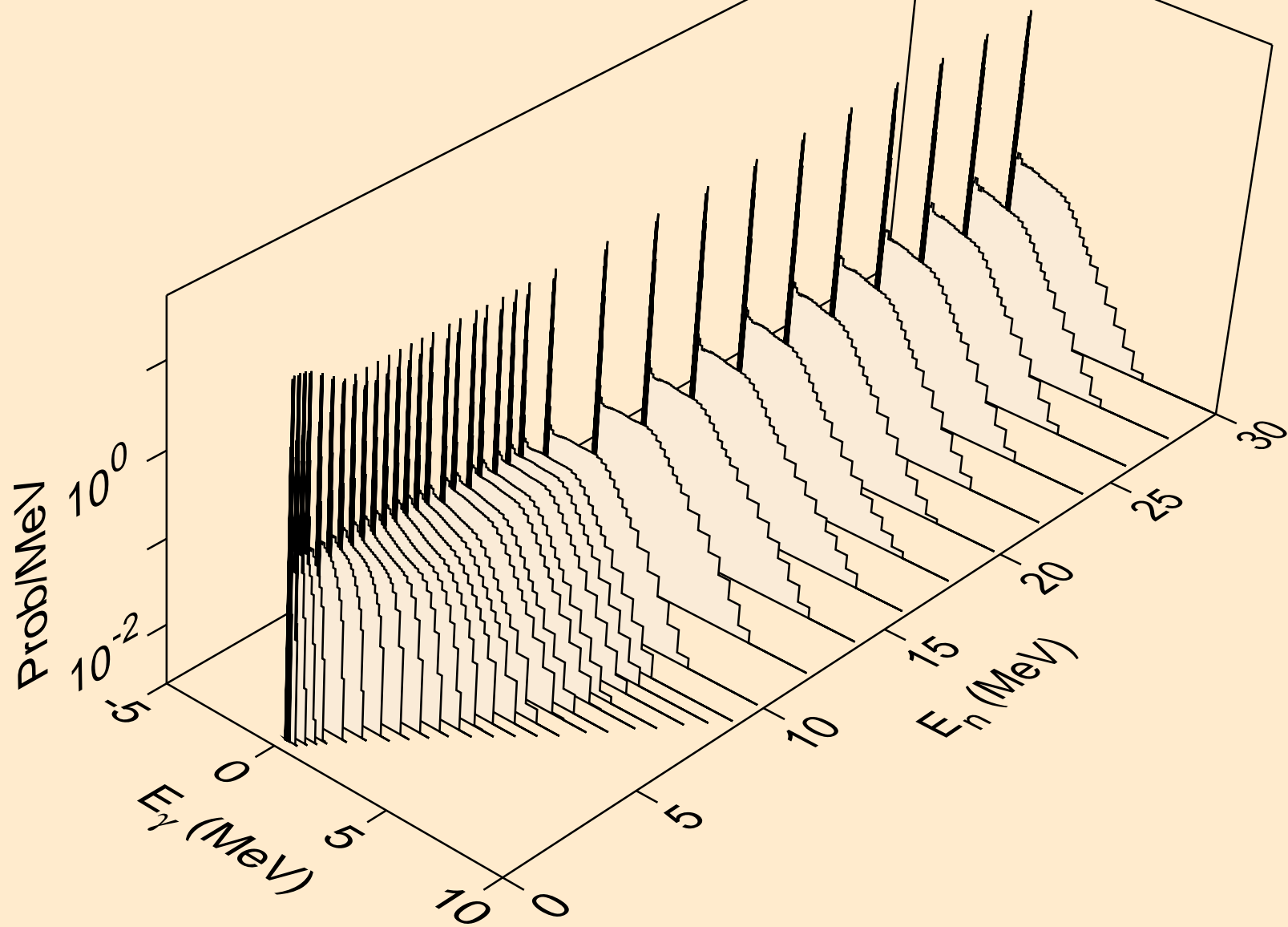

TM158 NEUTRON ACER TENDL-2024 LIBRARY; T=293.6K
Photon emission for (n,gma)

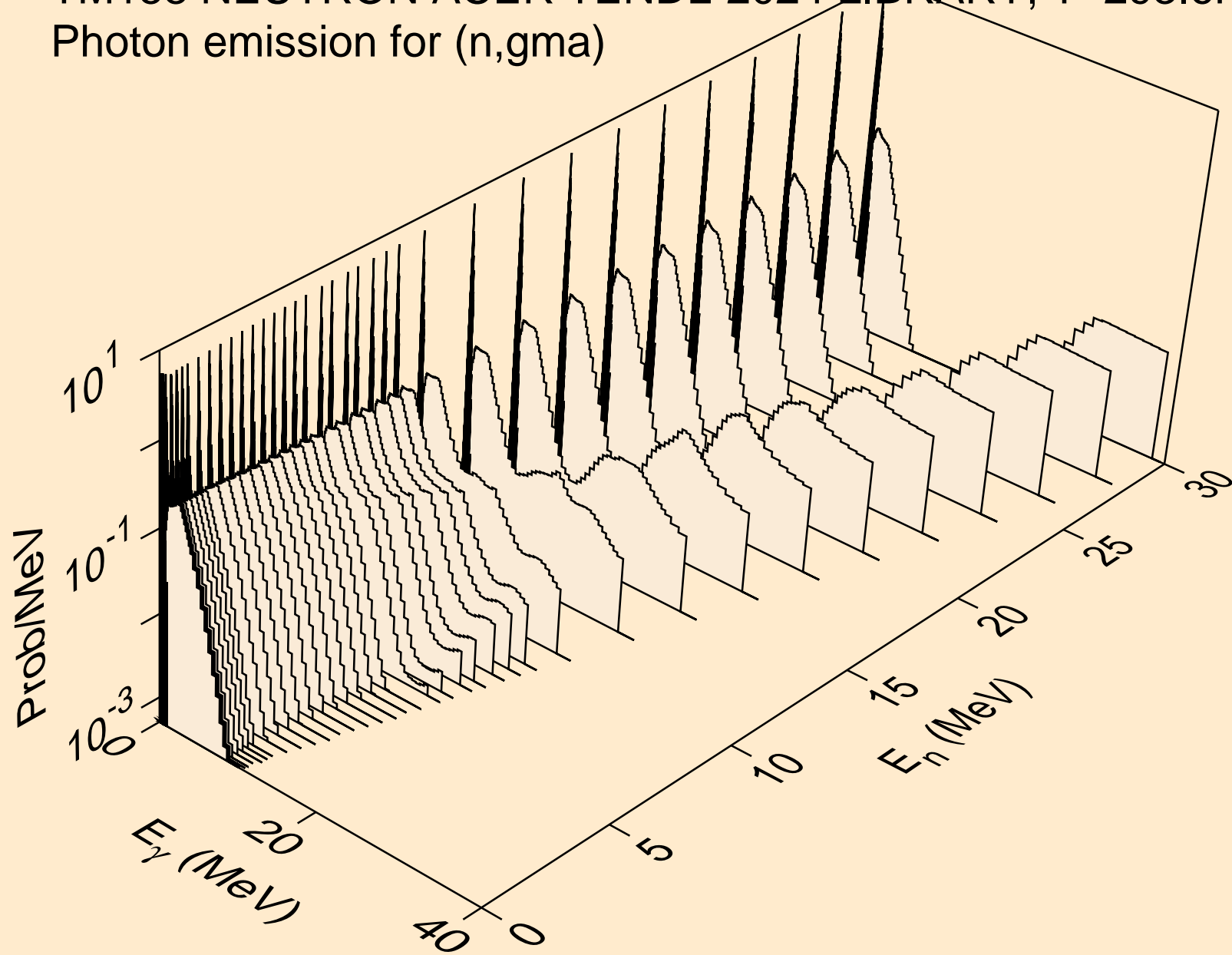

TM158 NEUTRON ACER TENDL-2024 LIBRARY; T=293.6K
Photon emission for (n,p)

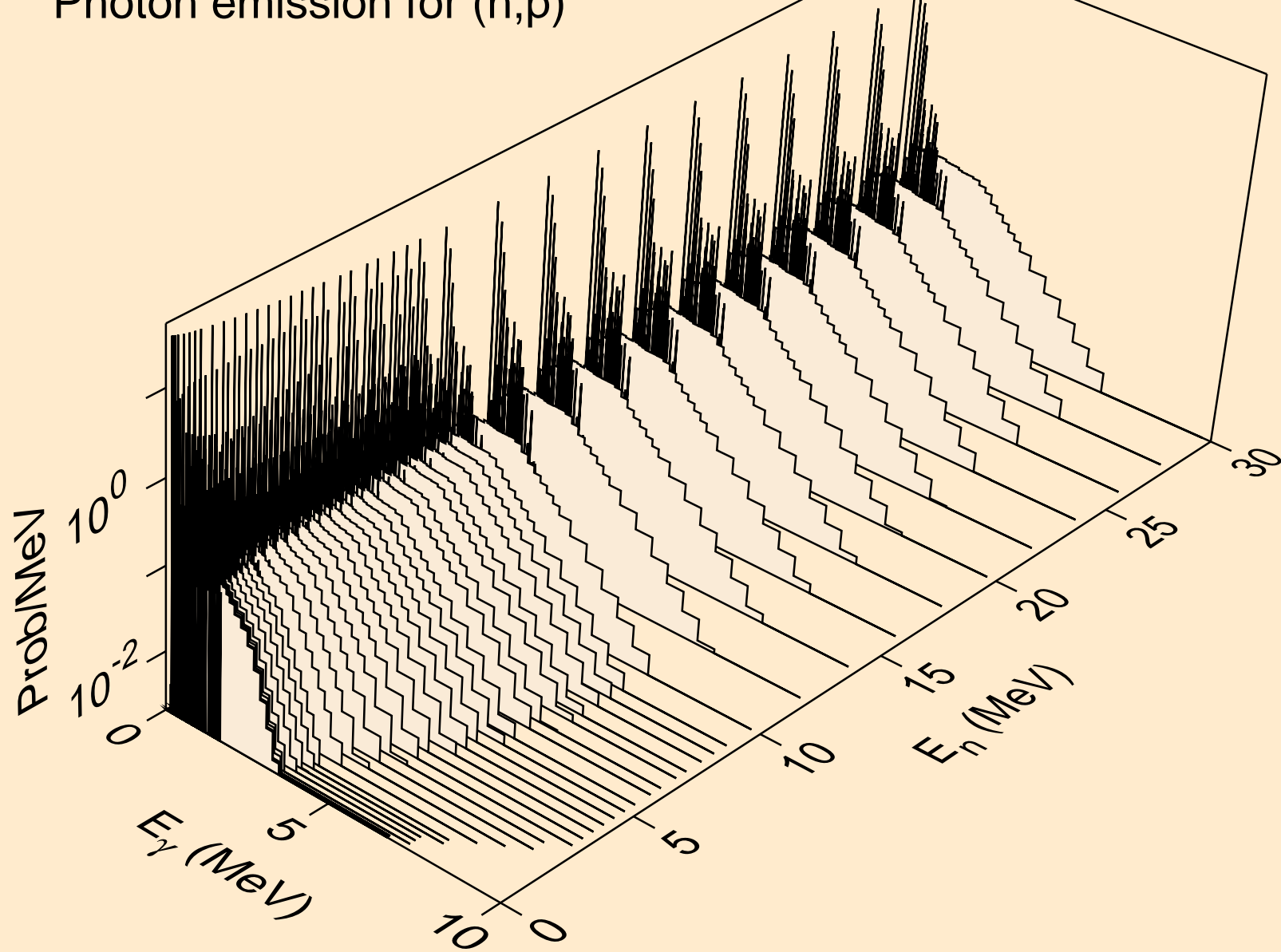

TM158 NEUTRON ACER TENDL-2024 LIBRARY; T=293.6K
Photon emission for (n,d)

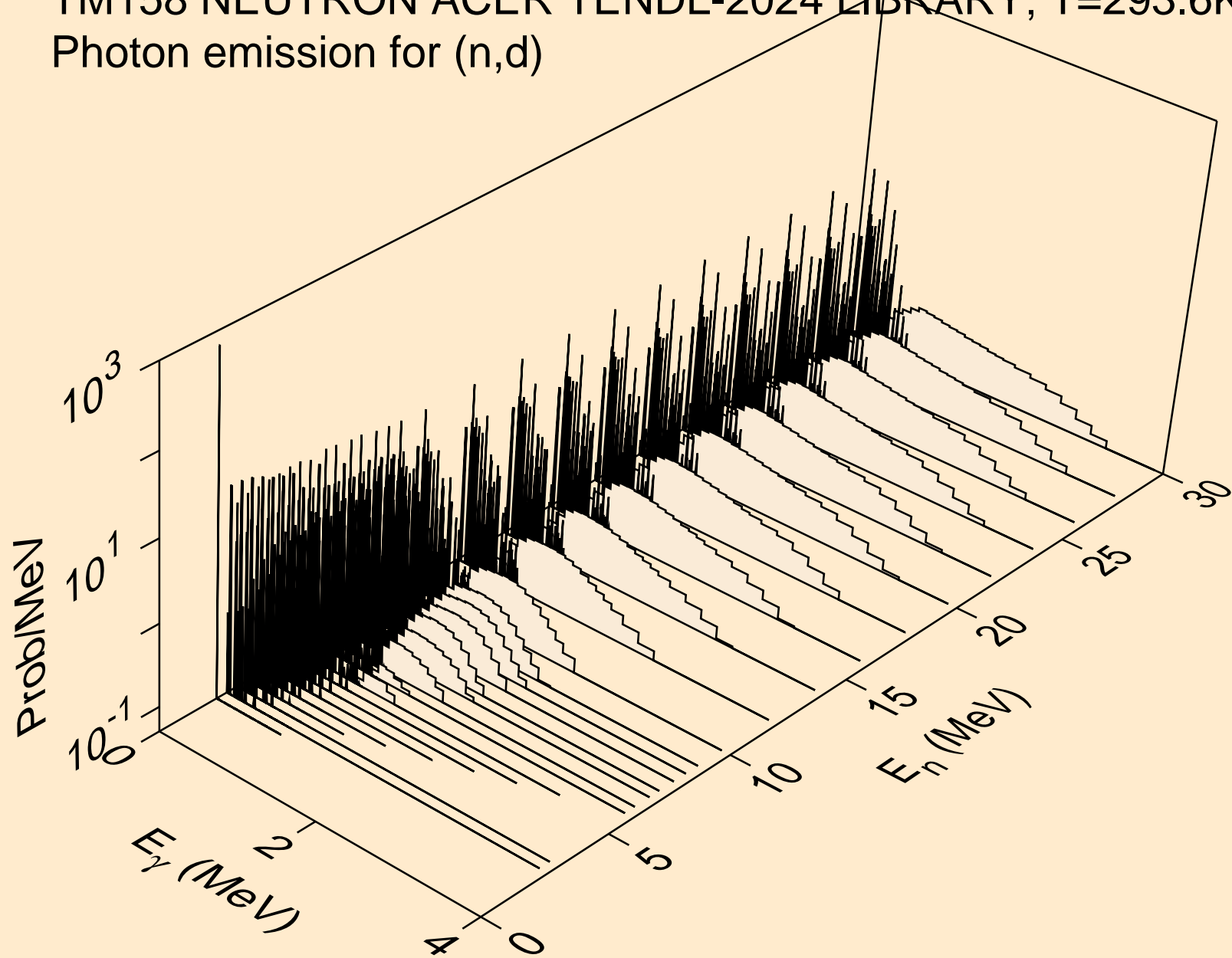

TM158 NEUTRON ACER TENDL-2024 LIBRARY; T=293.6K
Photon emission for (n,t)

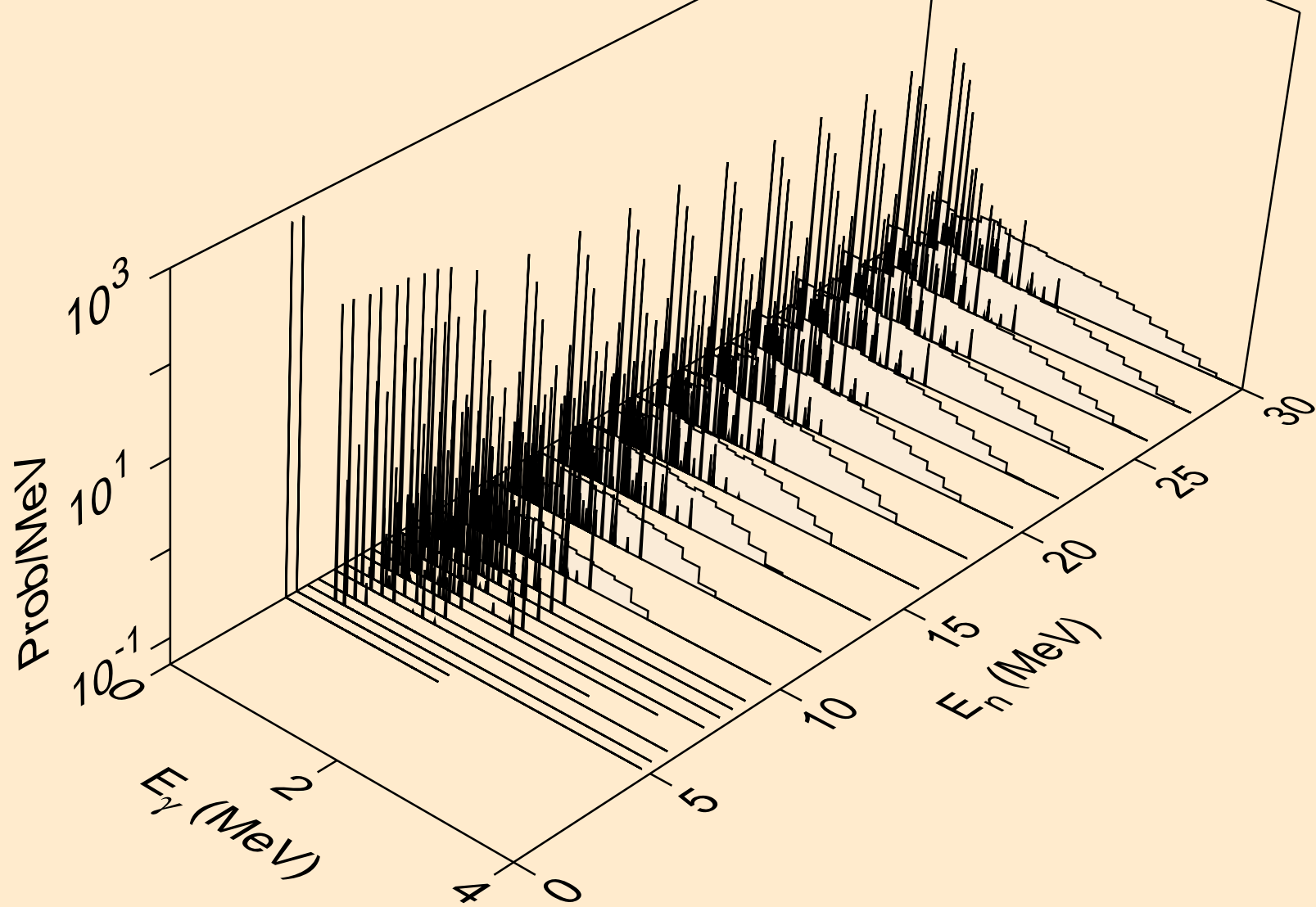

TM158 NEUTRON ACER TENDL-2024 LIBRARY; T=293.6K
Photon emission for (n,he3)

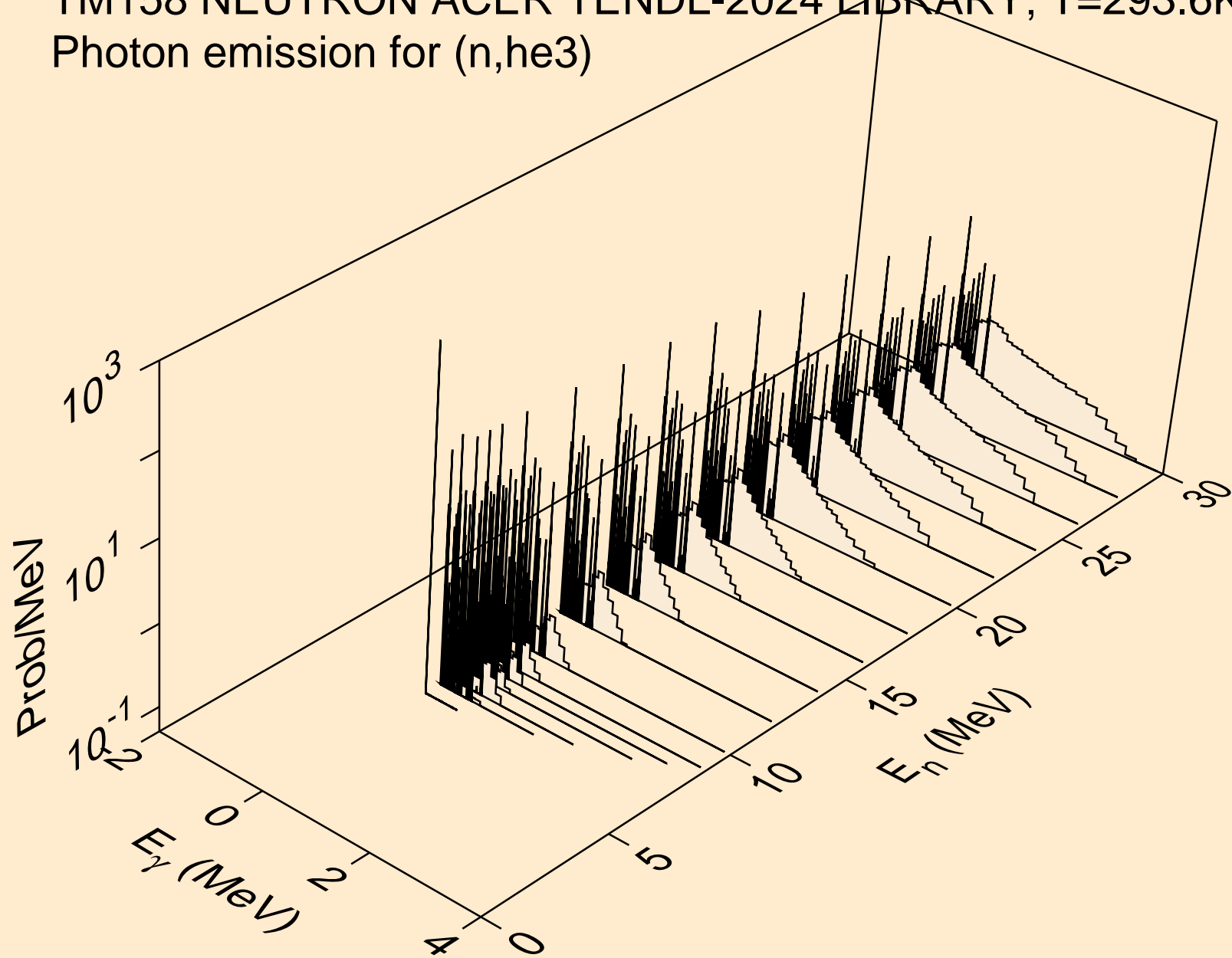

TM158 NEUTRON ACER TENDL-2024 LIBRARY; T=293.6K
Photon emission for (n,a)

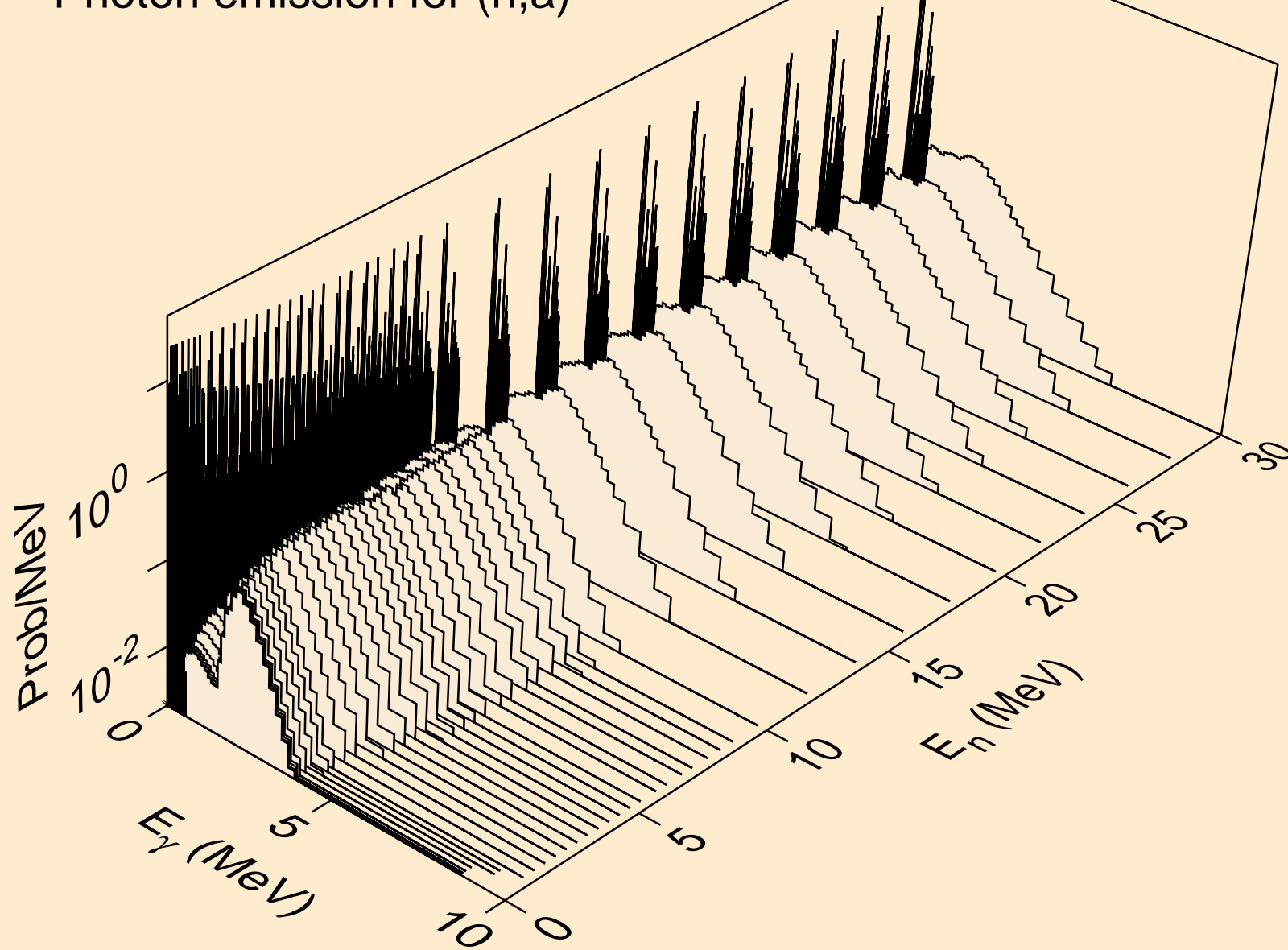

TM158 NEUTRON ACER TENDL-2024 LIBRARY; T=293.6K
Photon emission for (n,2a)

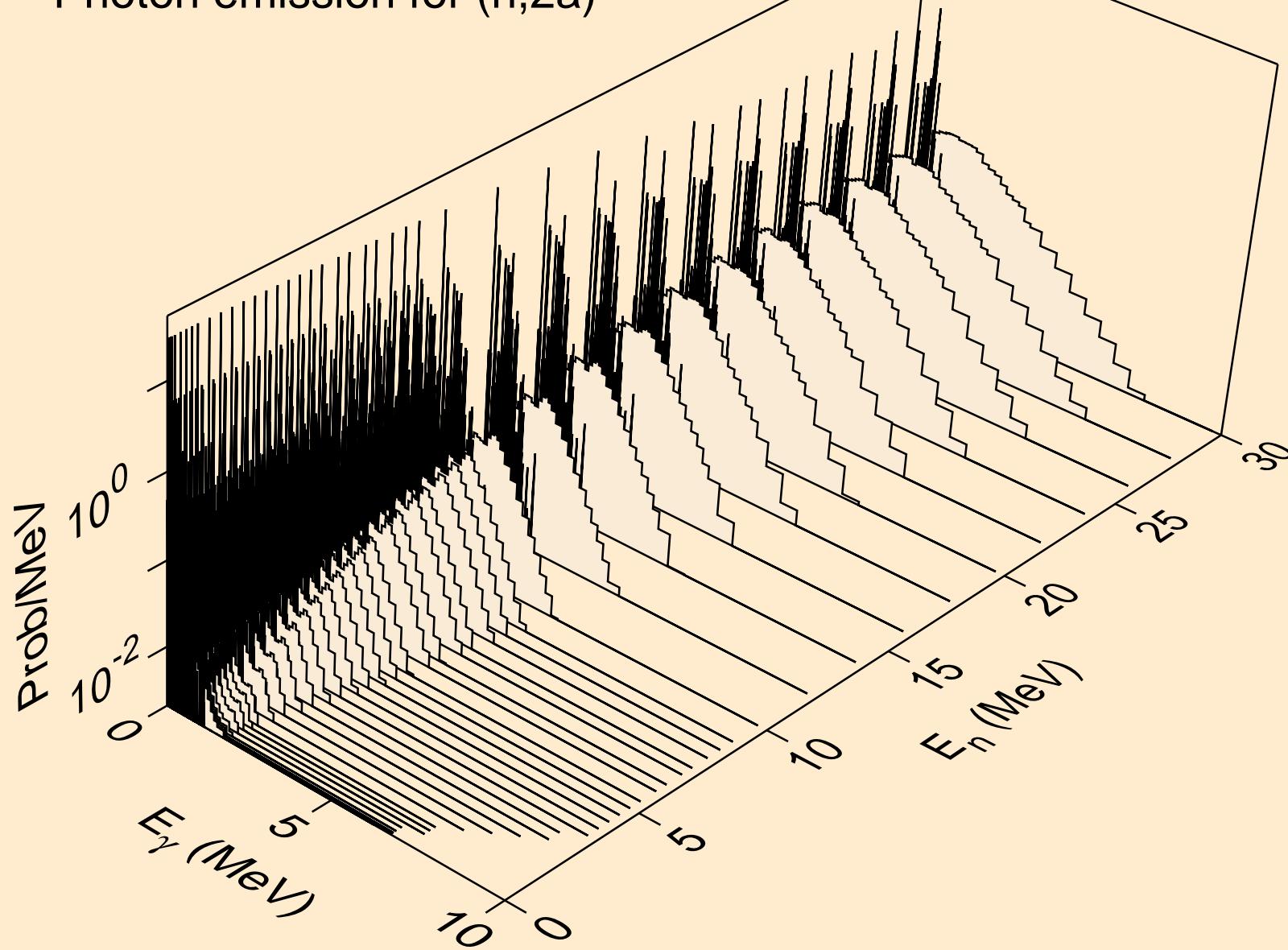

TM158 NEUTRON ACER TENDL-2024 LIBRARY; T=293.6K
Photon emission for (n,3a)

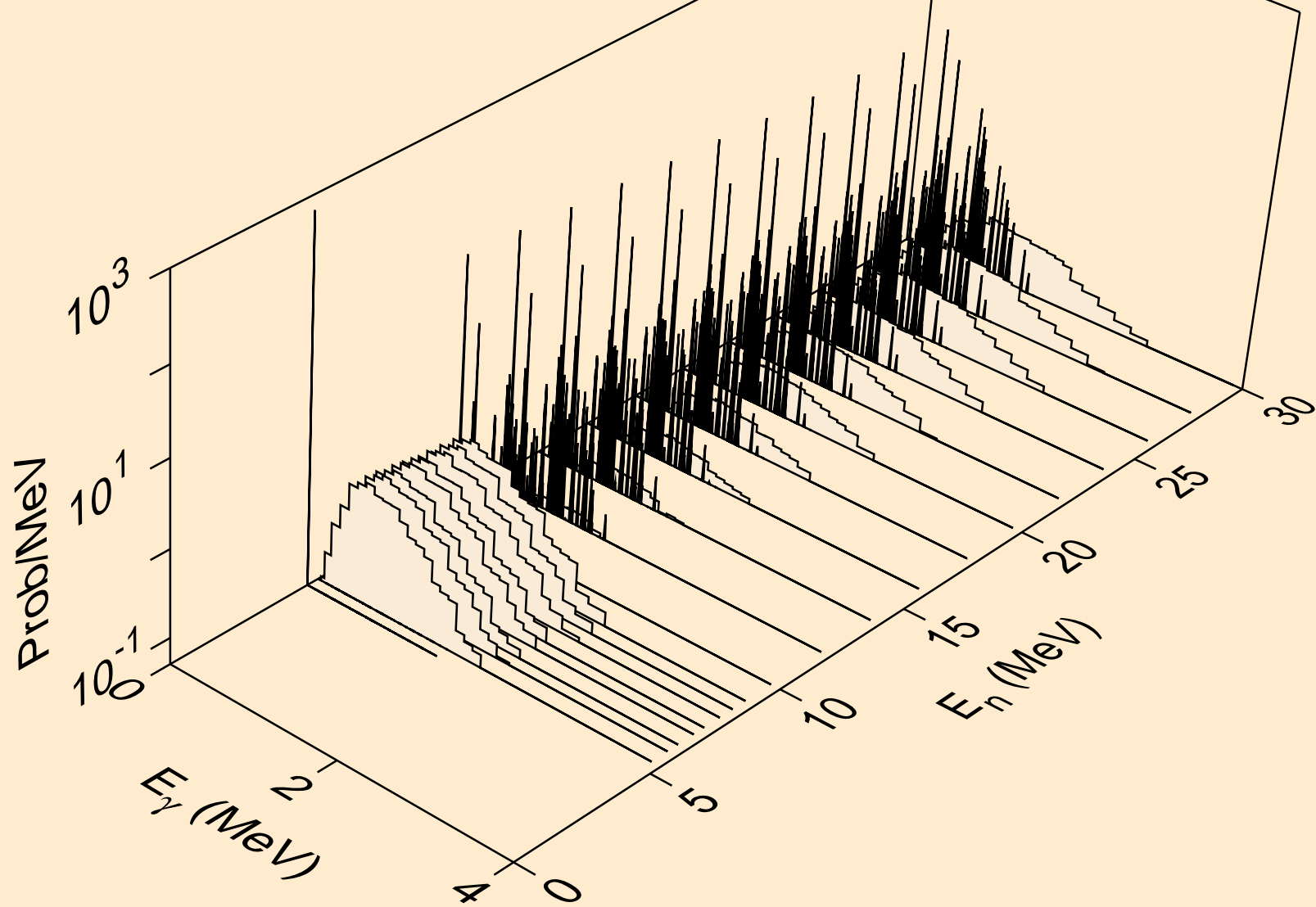

TM158 NEUTRON ACER TENDL-2024 LIBRARY; T=293.6K
Photon emission for (n,2p)

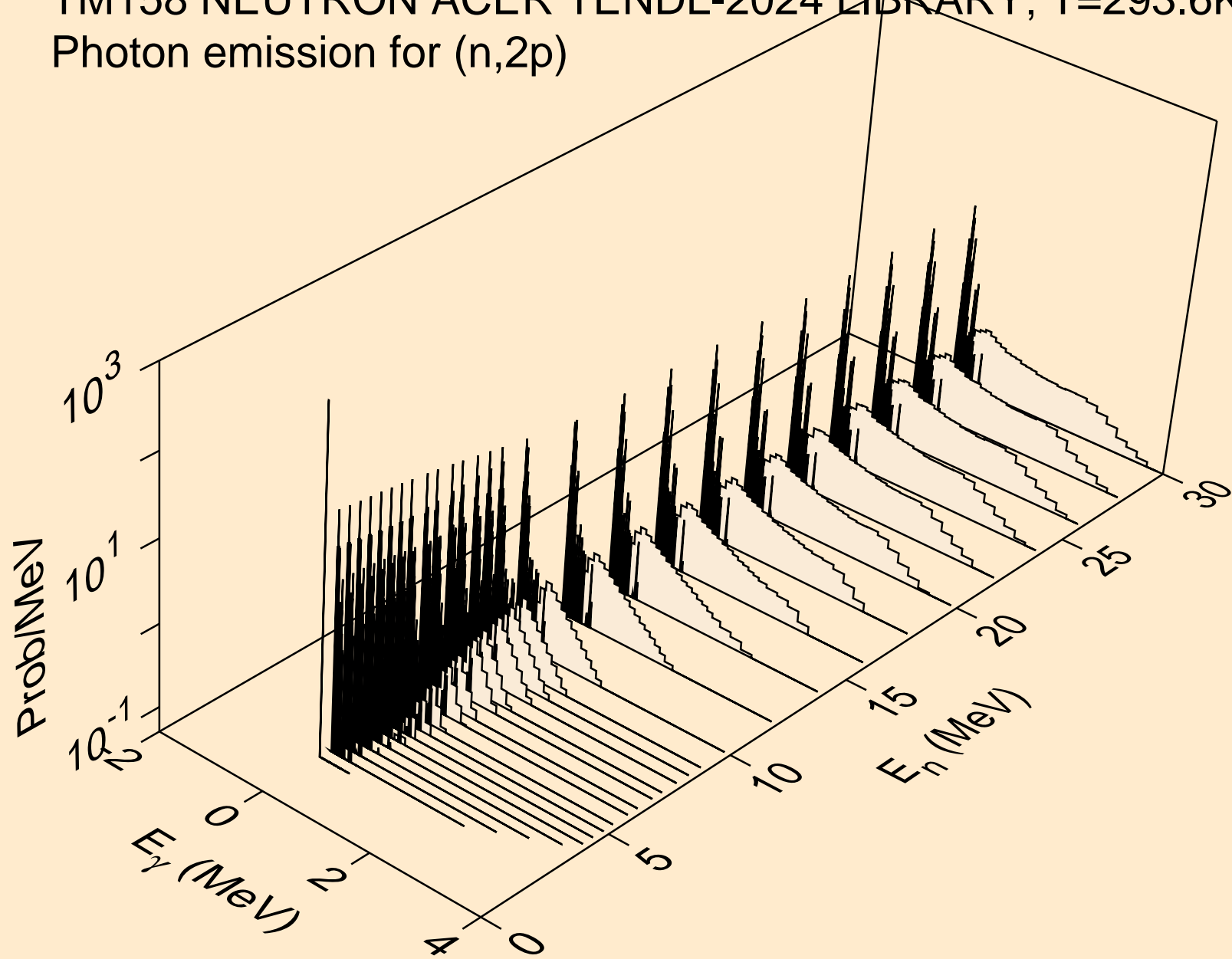

TM158 NEUTRON ACER TENDL-2024 LIBRARY; T=293.6K
Photon emission for (n,p)

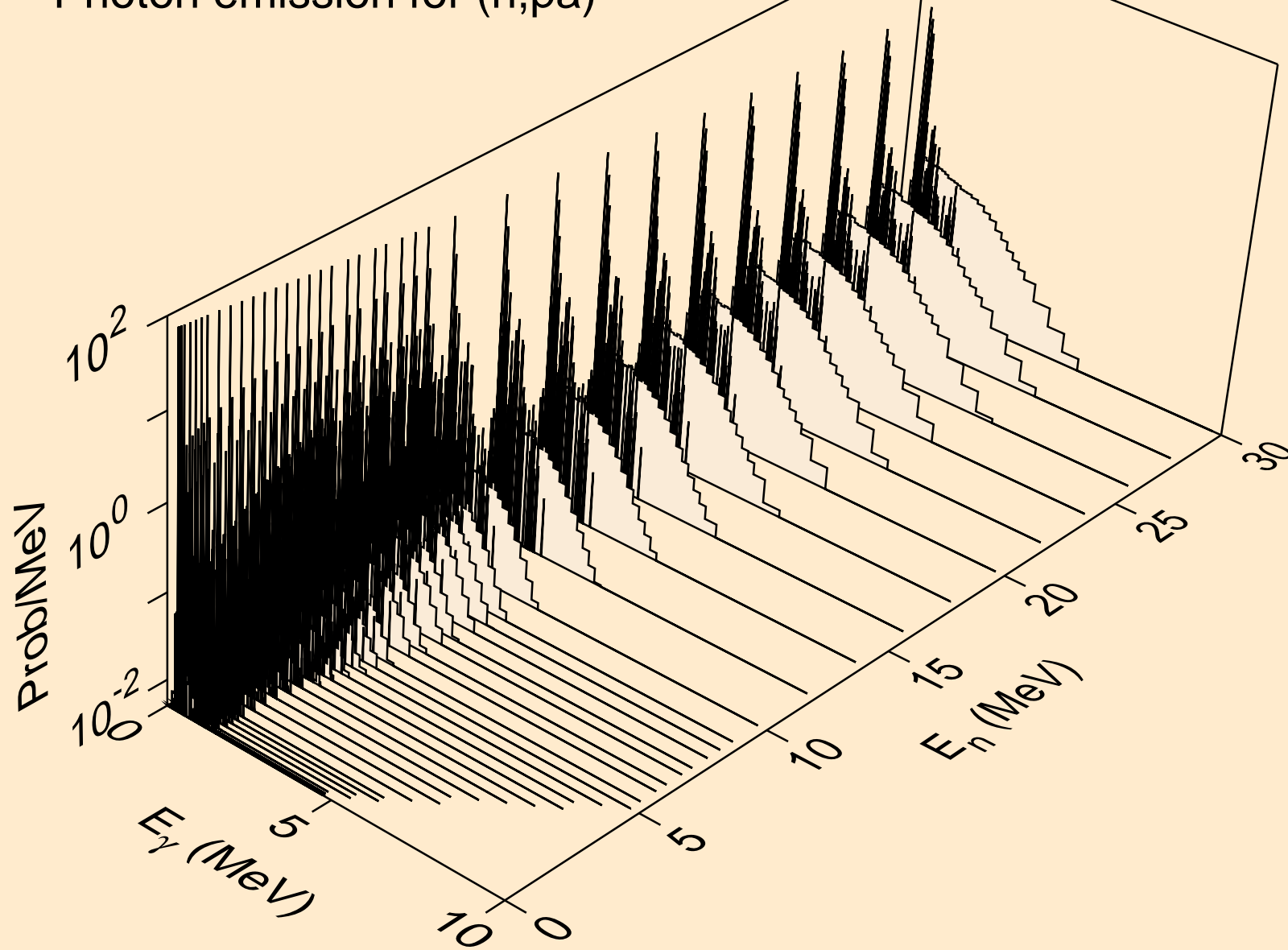

TM158 NEUTRON ACER TENDL-2024 LIBRARY; T=293.6K
Photon emission for (n,t2a)

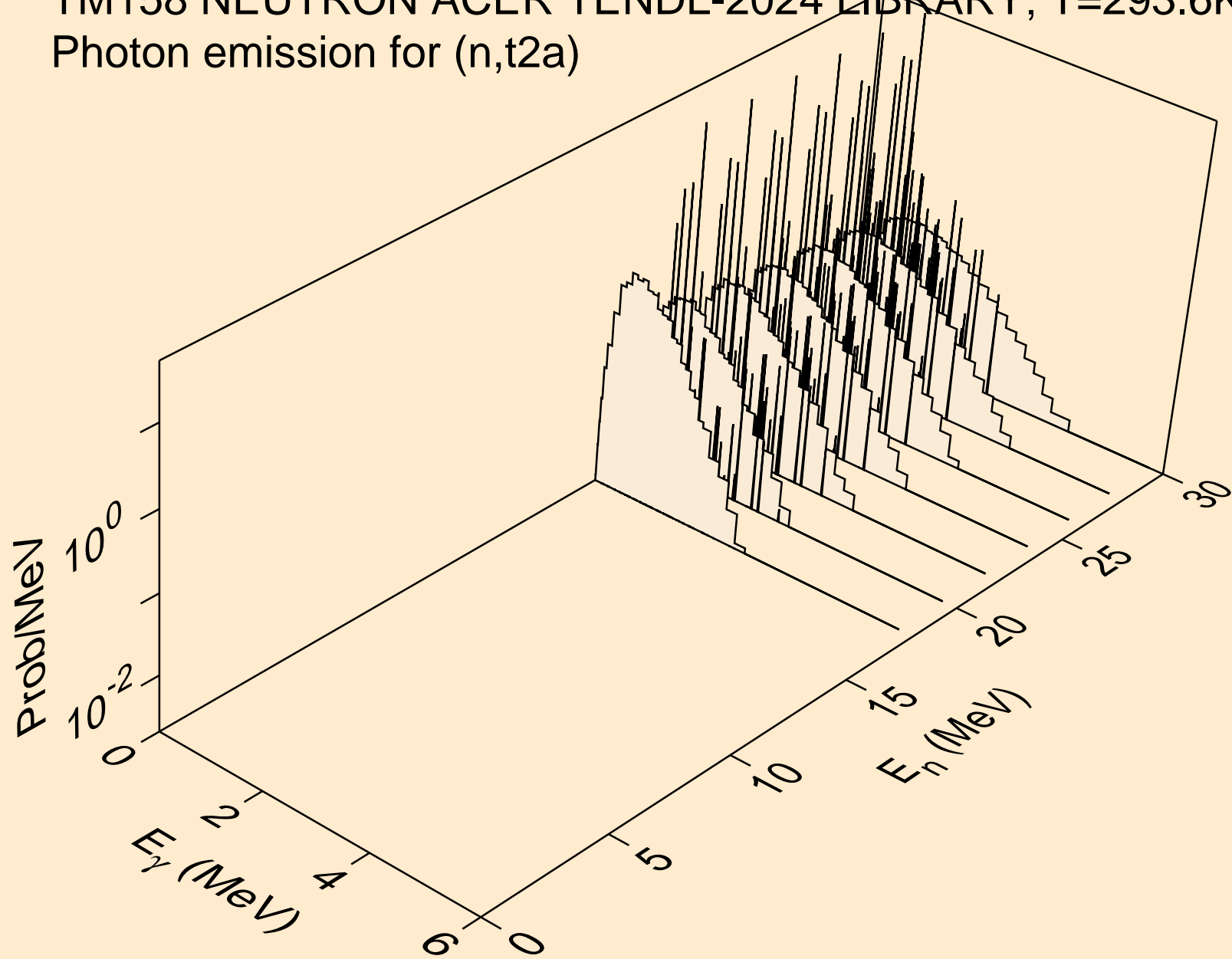

TM158 NEUTRON ACER TENDL-2024 LIBRARY; T=293.6K
Photon emission for (n,pd)

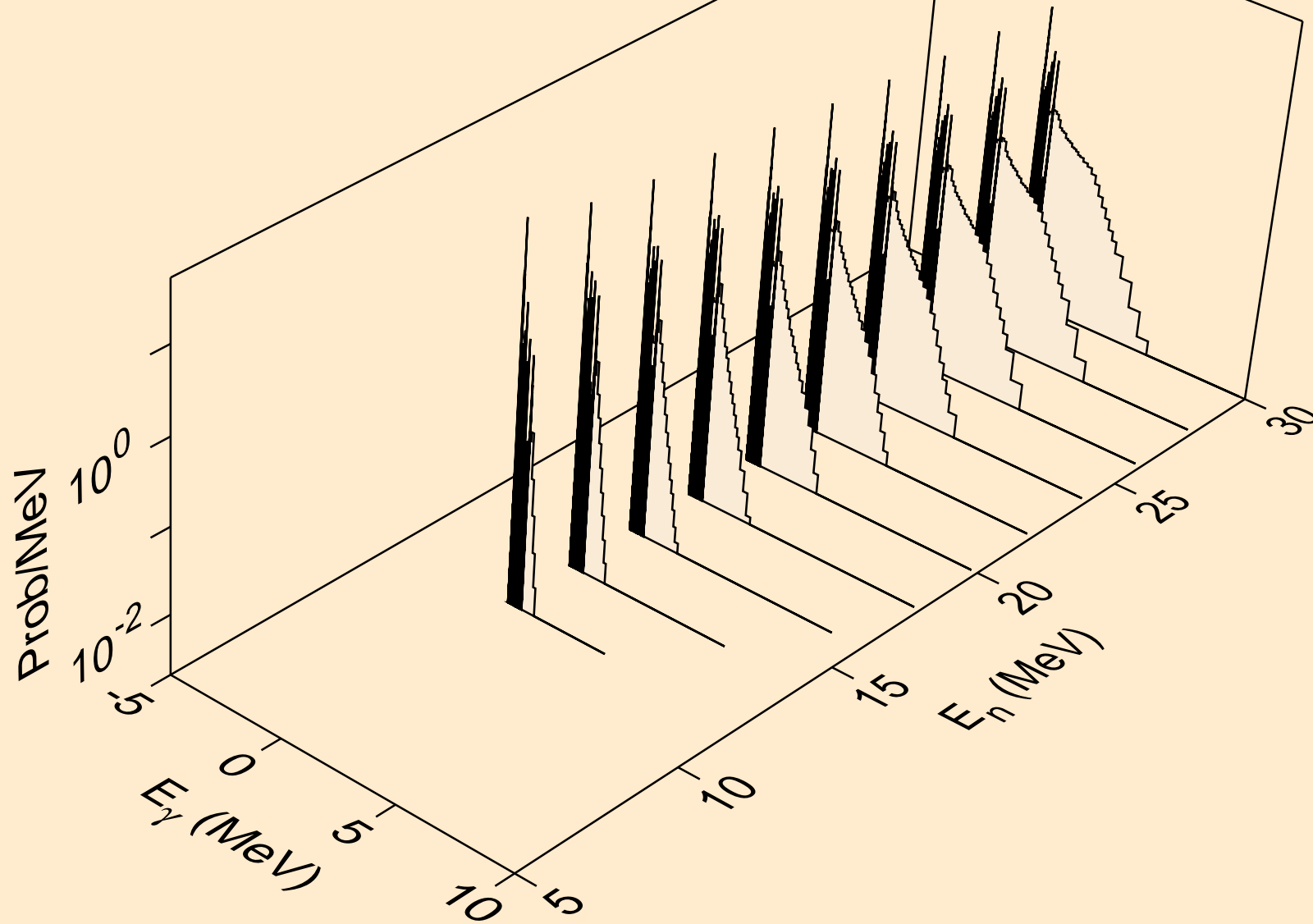

TM158 NEUTRON ACER TENDL-2024 LIBRARY; T=293.6K
Photon emission for (n,pt)

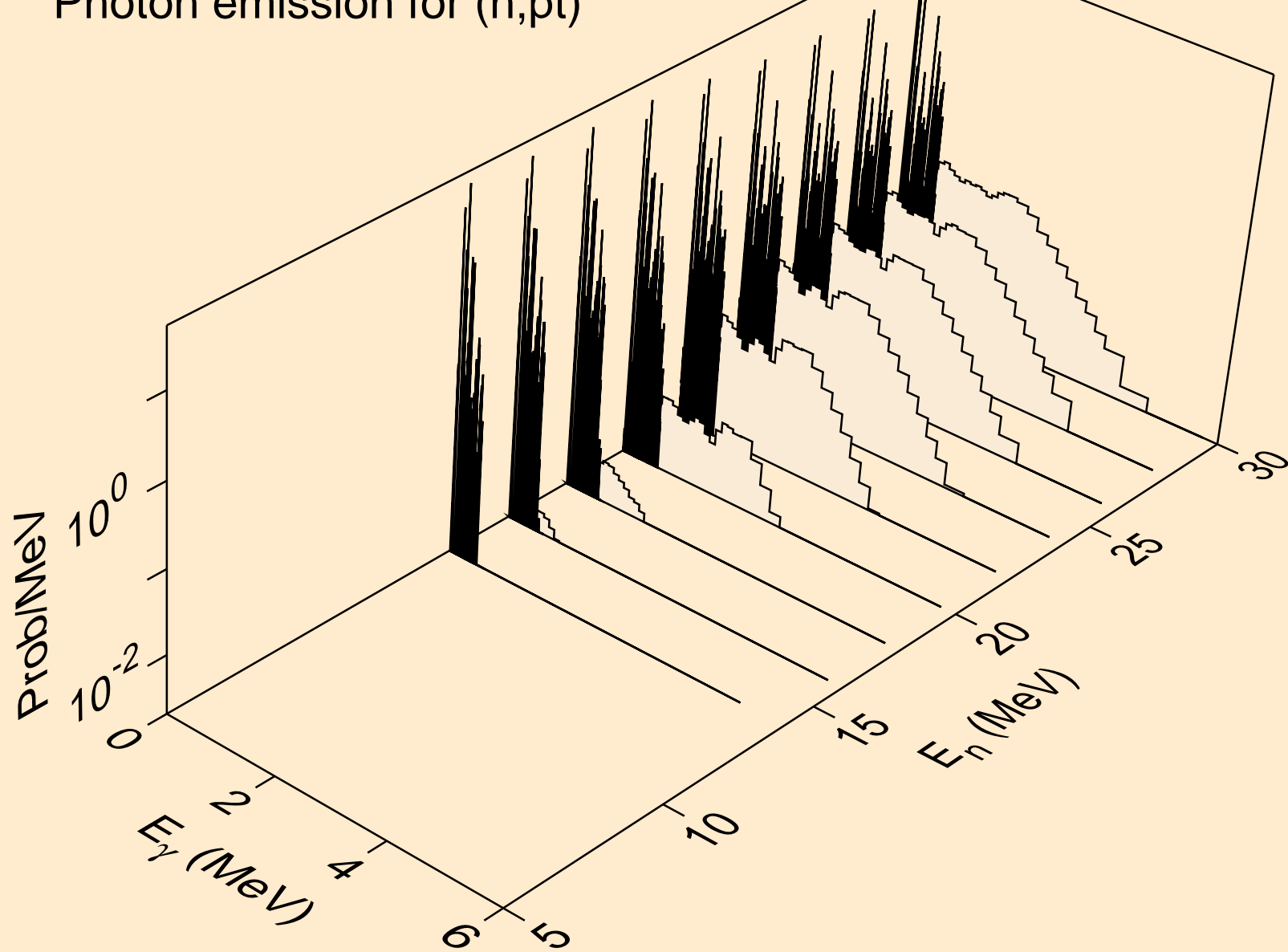

TM158 NEUTRON ACER TENDL-2024 LIBRARY; T=293.6K
Photon emission for (n,da)

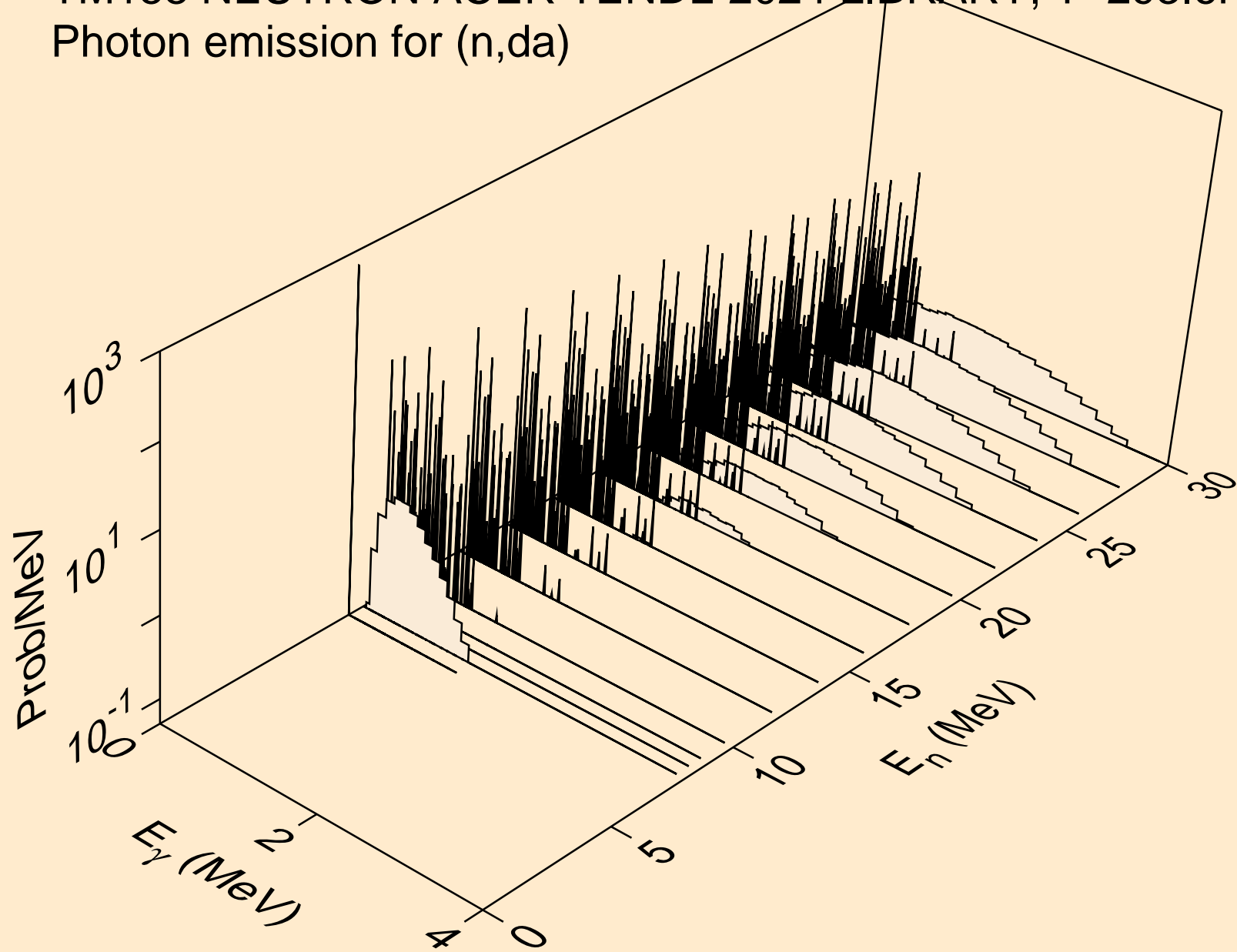

TM158 NEUTRON ACER TENDL-2024 LIBRARY; T=293.6K
thermal capture photon spectrum

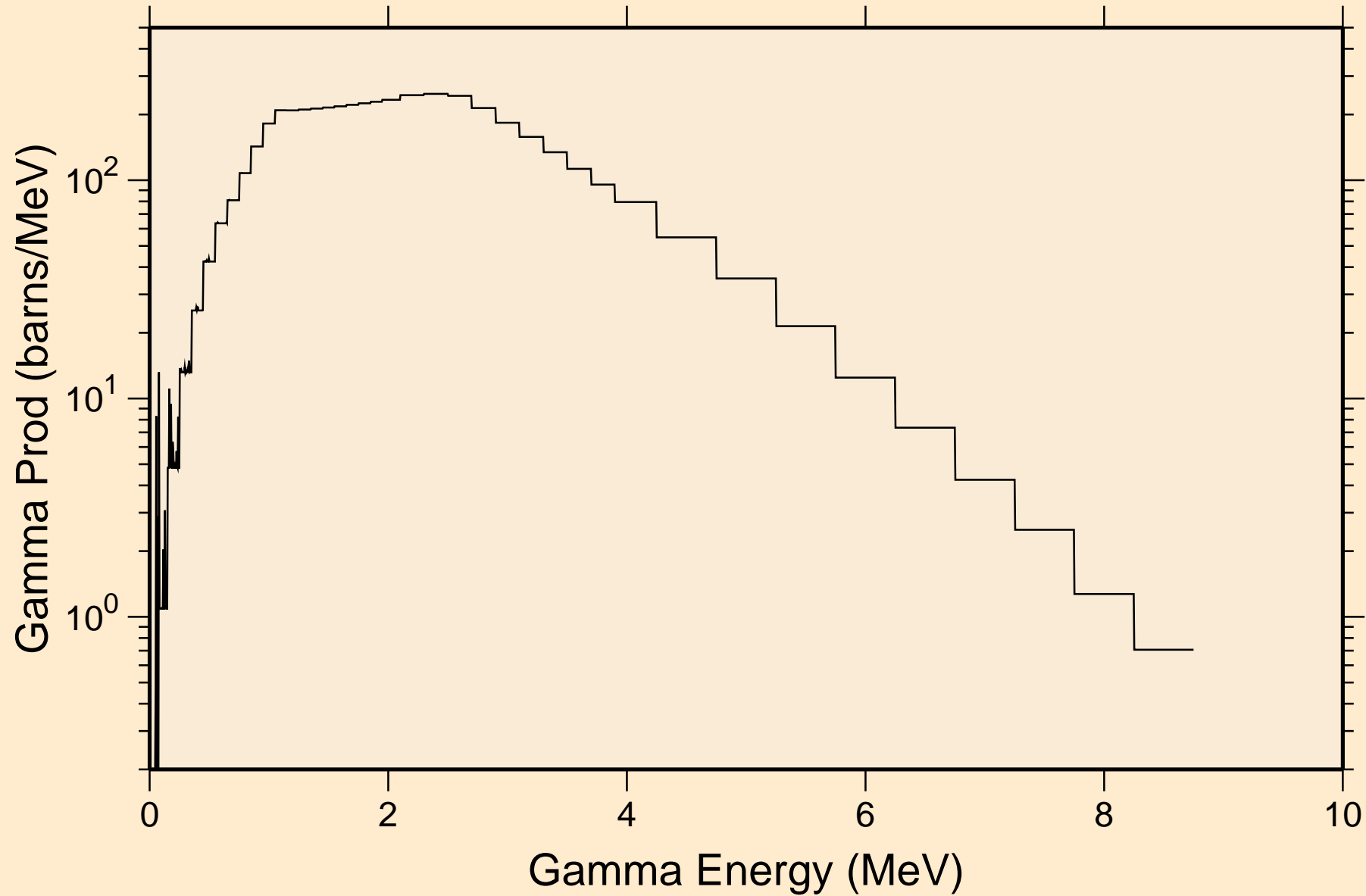

TM158 NEUTRON ACER TENDL-2024 LIBRARY; T=293.6K
14 MeV photon spectrum

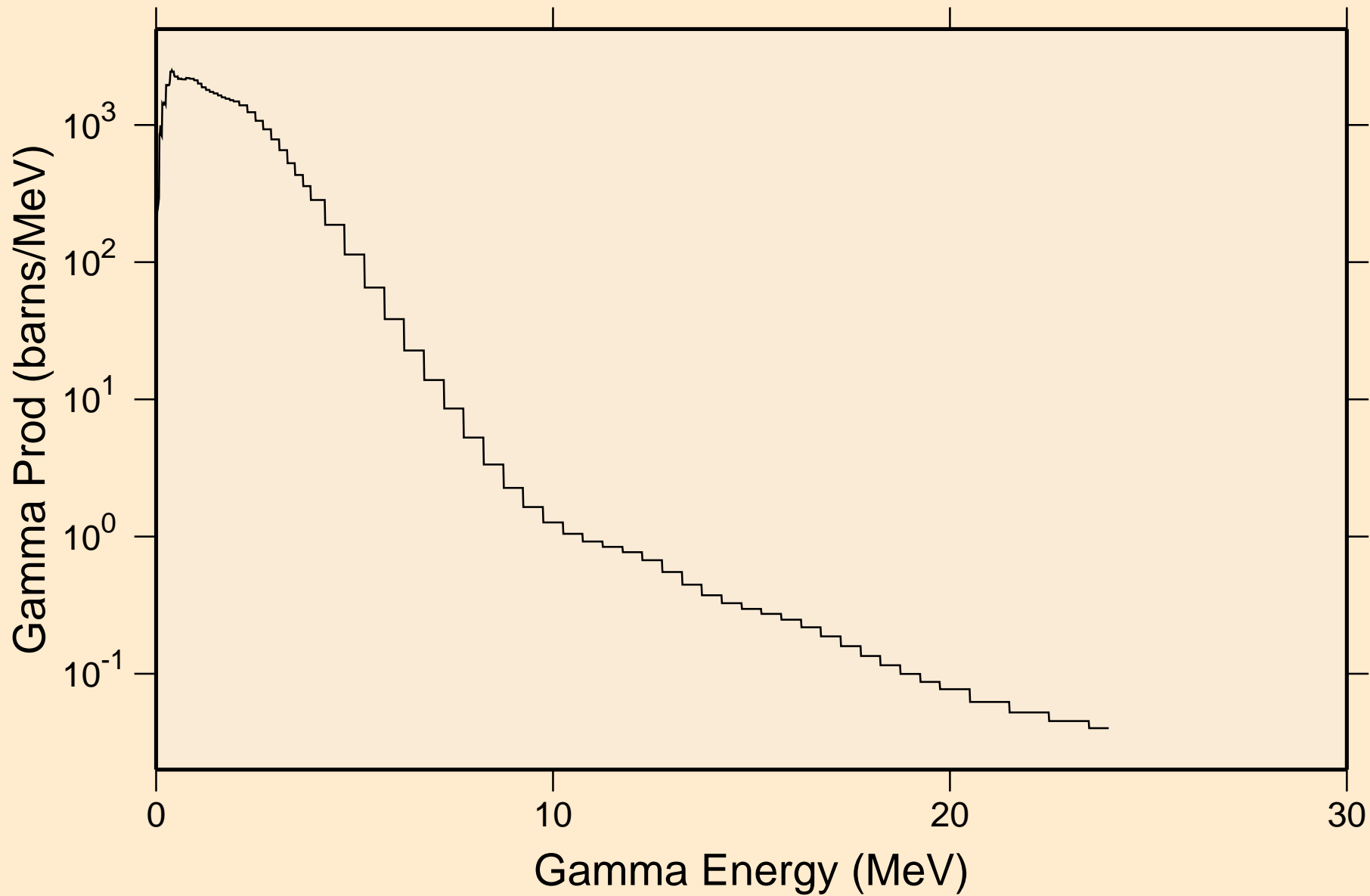

TM158 NEUTRON ACER TENDL-2024 LIBRARY; T=293.6K

Particle heating contributions

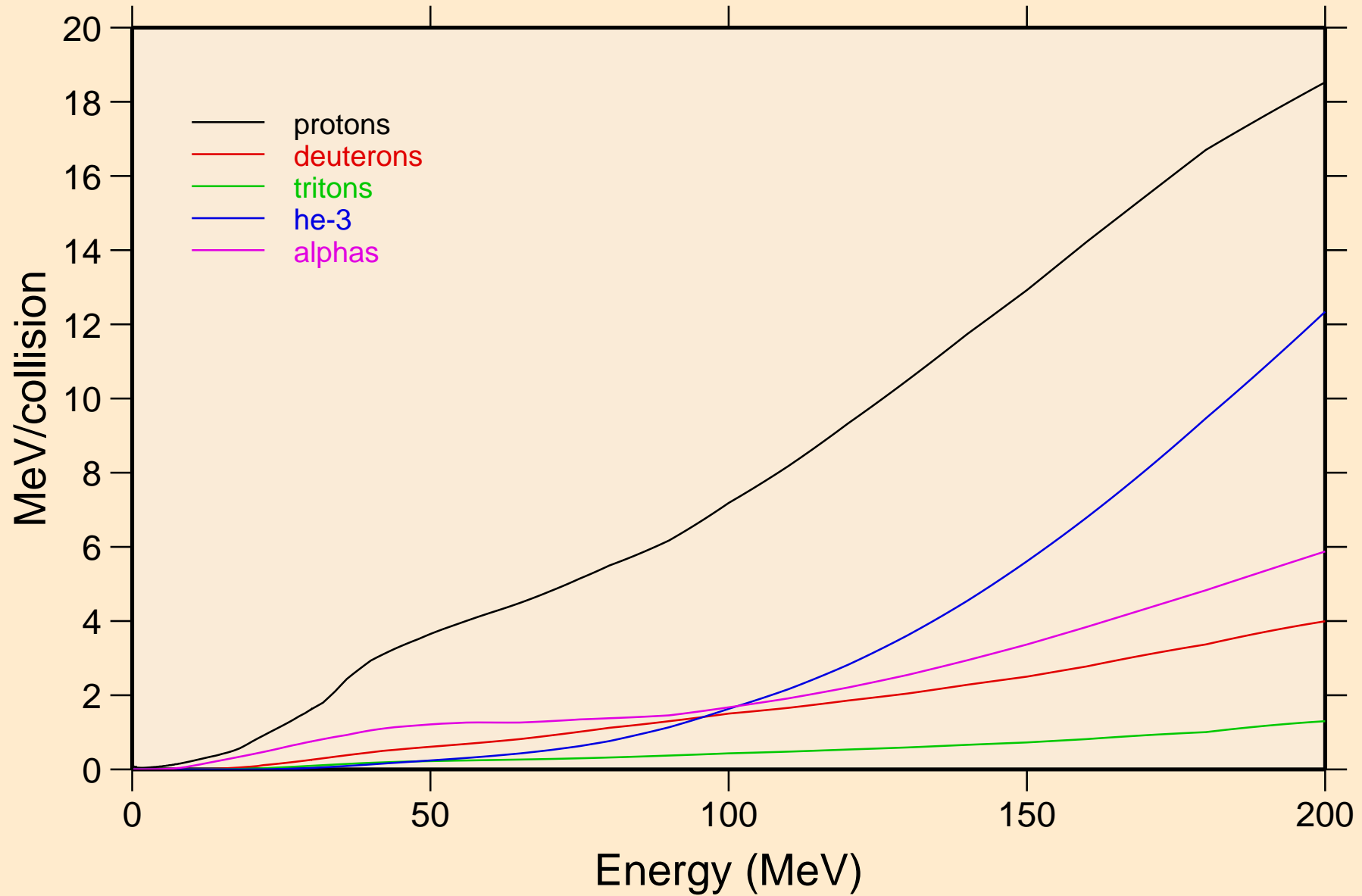

TM158 NEUTRON ACER TENDL-2024 LIBRARY; T=293.6K
Recoil Heating

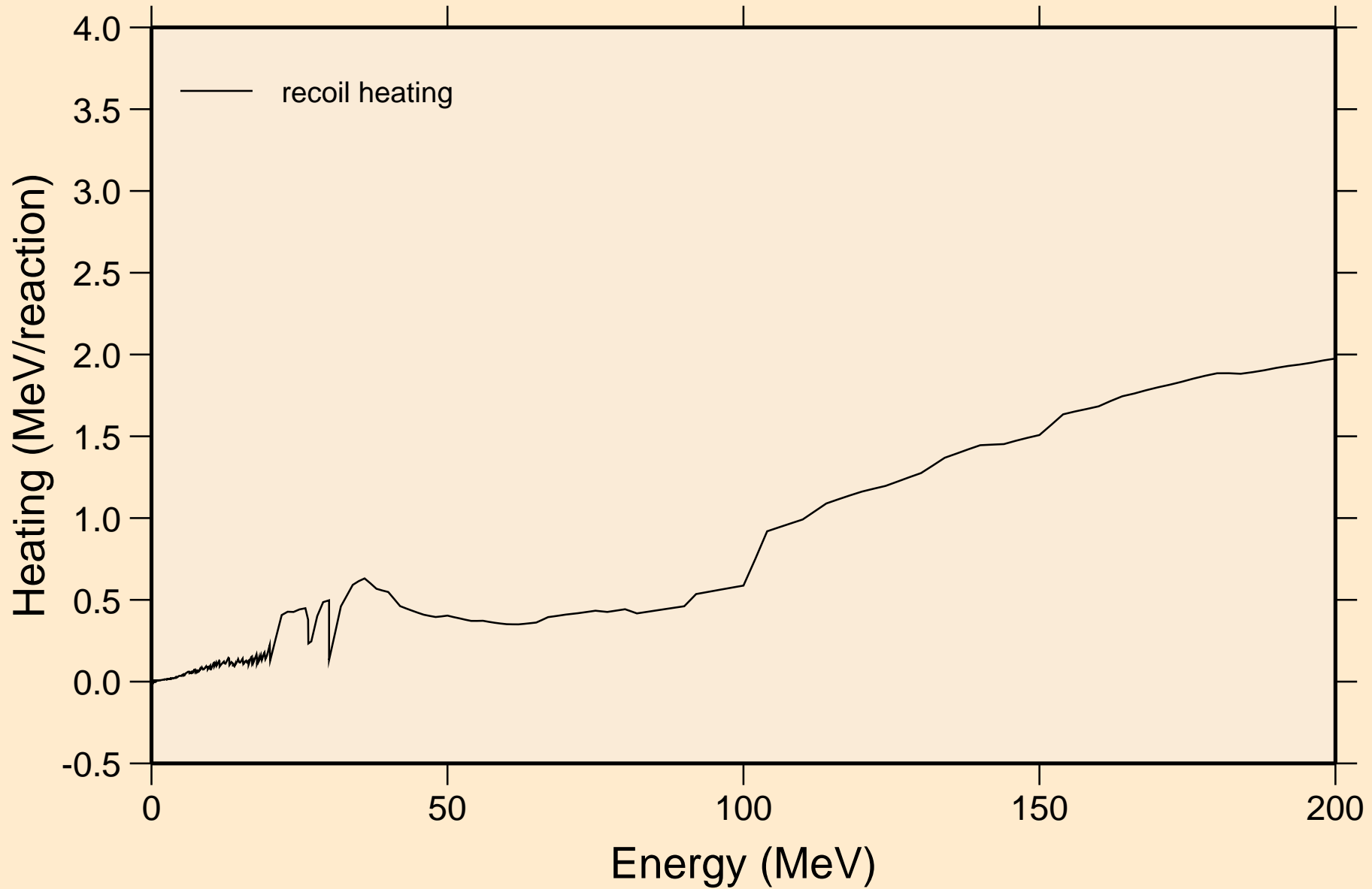

TM158 NEUTRON ACER TENDL-2024 LIBRARY; T=293.6K
Particle production cross sections

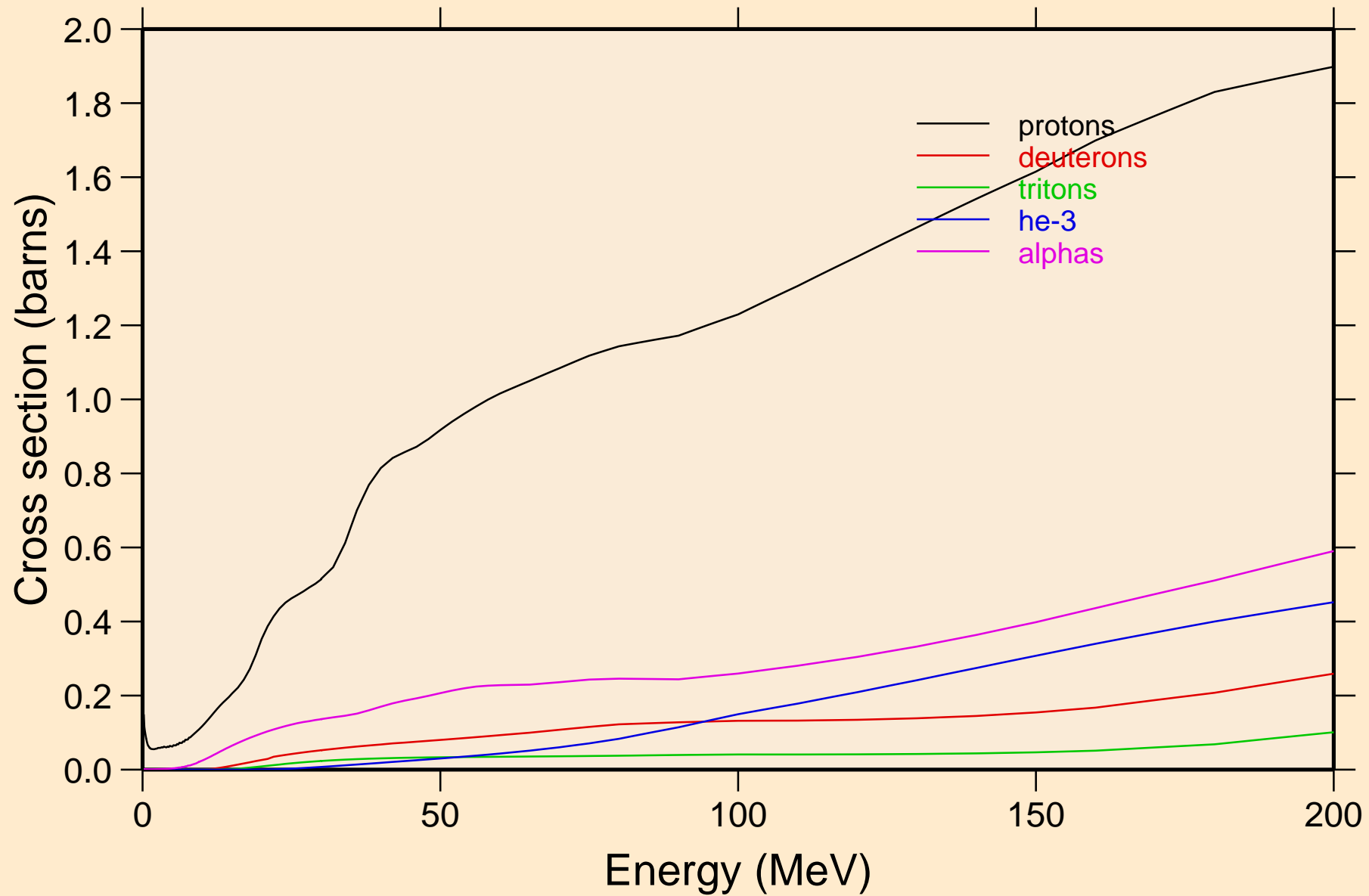

TM158 NEUTRON ACER TENDL-2024 LIBRARY; T=293.6K
protons from (n,x)

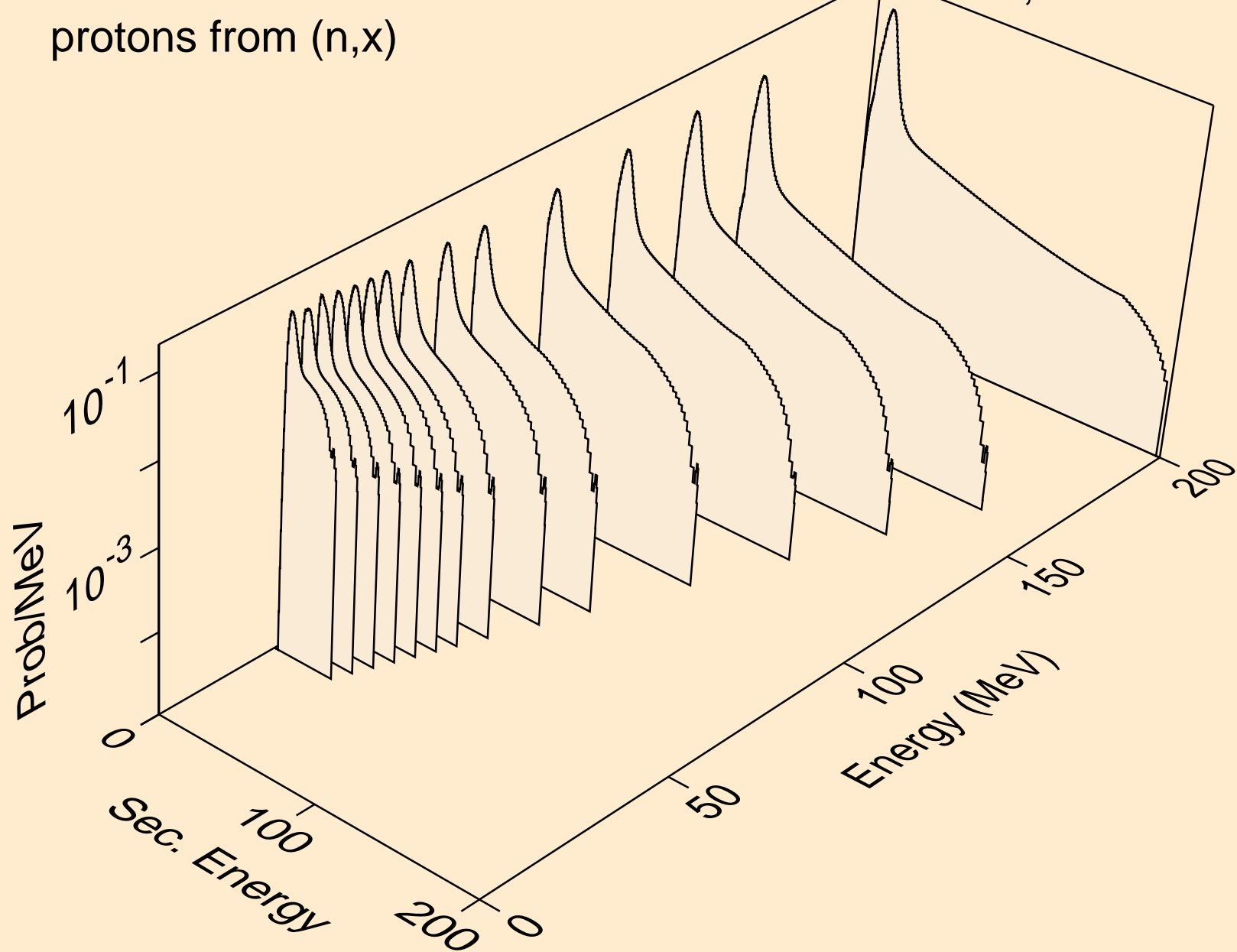

TM158 NEUTRON ACER TENDL-2024 LIBRARY; T=293.6K
protons from (n,n*)p

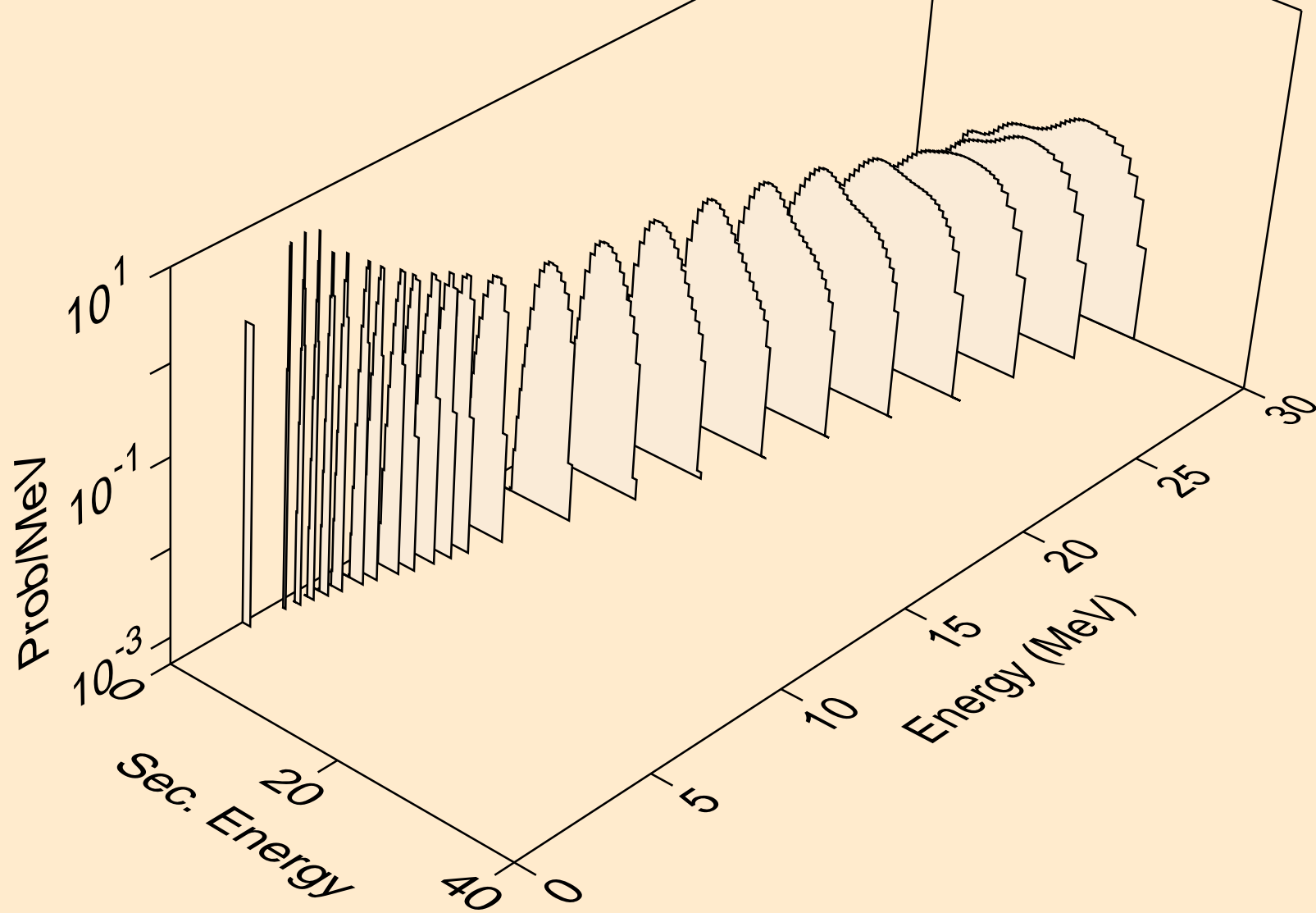

TM158 NEUTRON ACER TENDL-2024 LIBRARY; T=293.6K
protons from (n,2np)

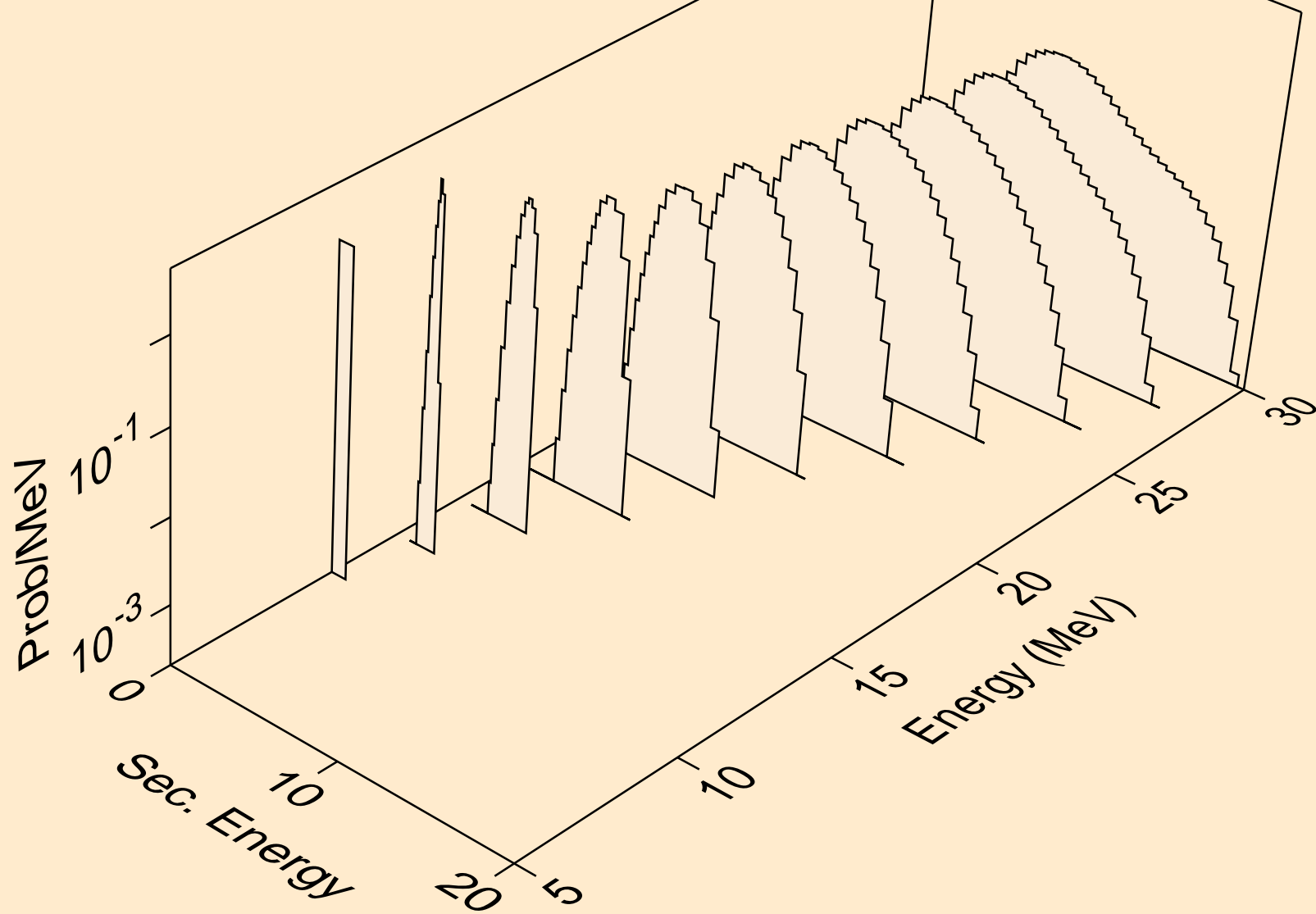

TM158 NEUTRON ACER TENDL-2024 LIBRARY; T=293.6K
protons from (n,3np)

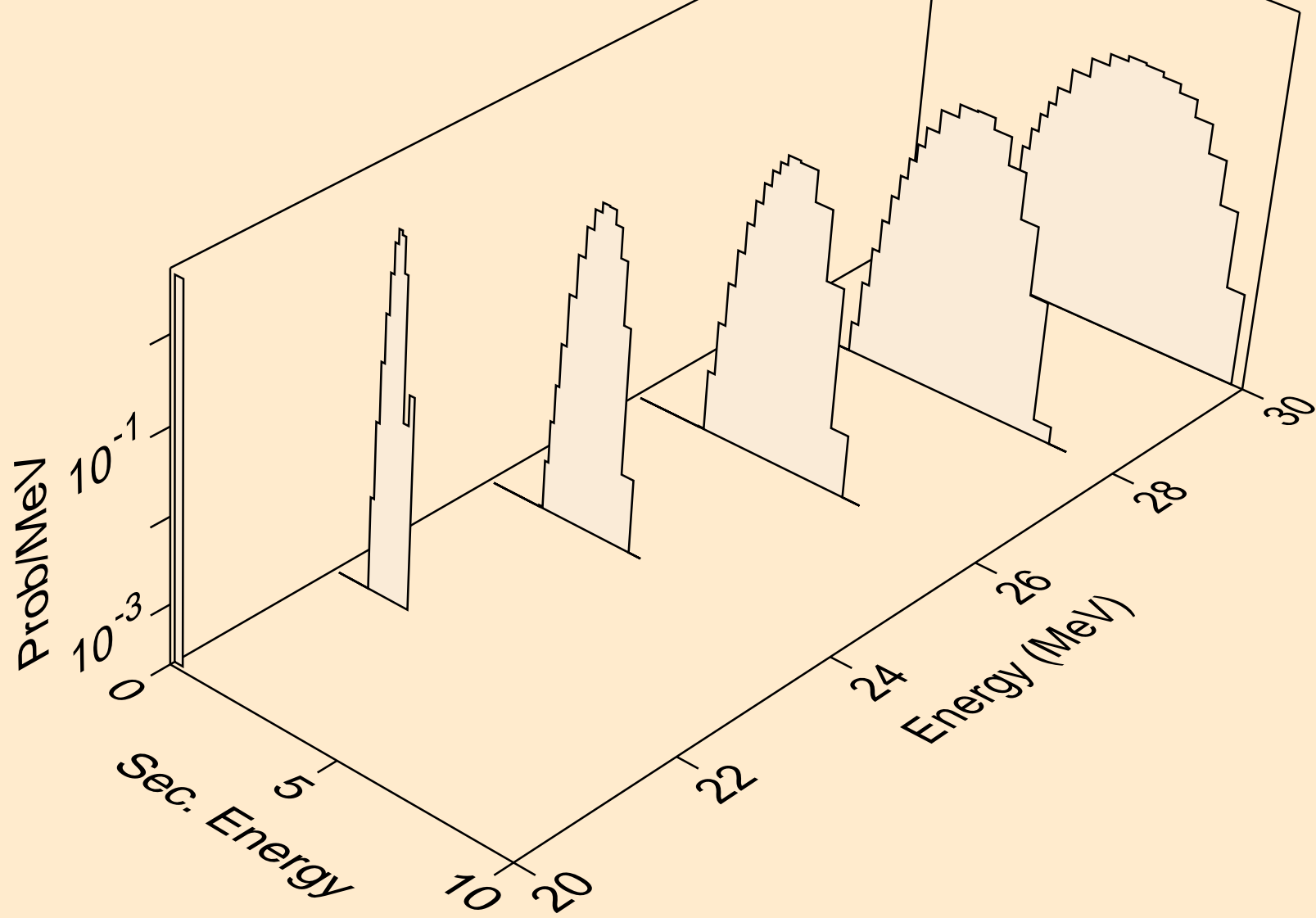

TM158 NEUTRON ACER TENDL-2024 LIBRARY; T=293.6K
protons from (n,n2p)

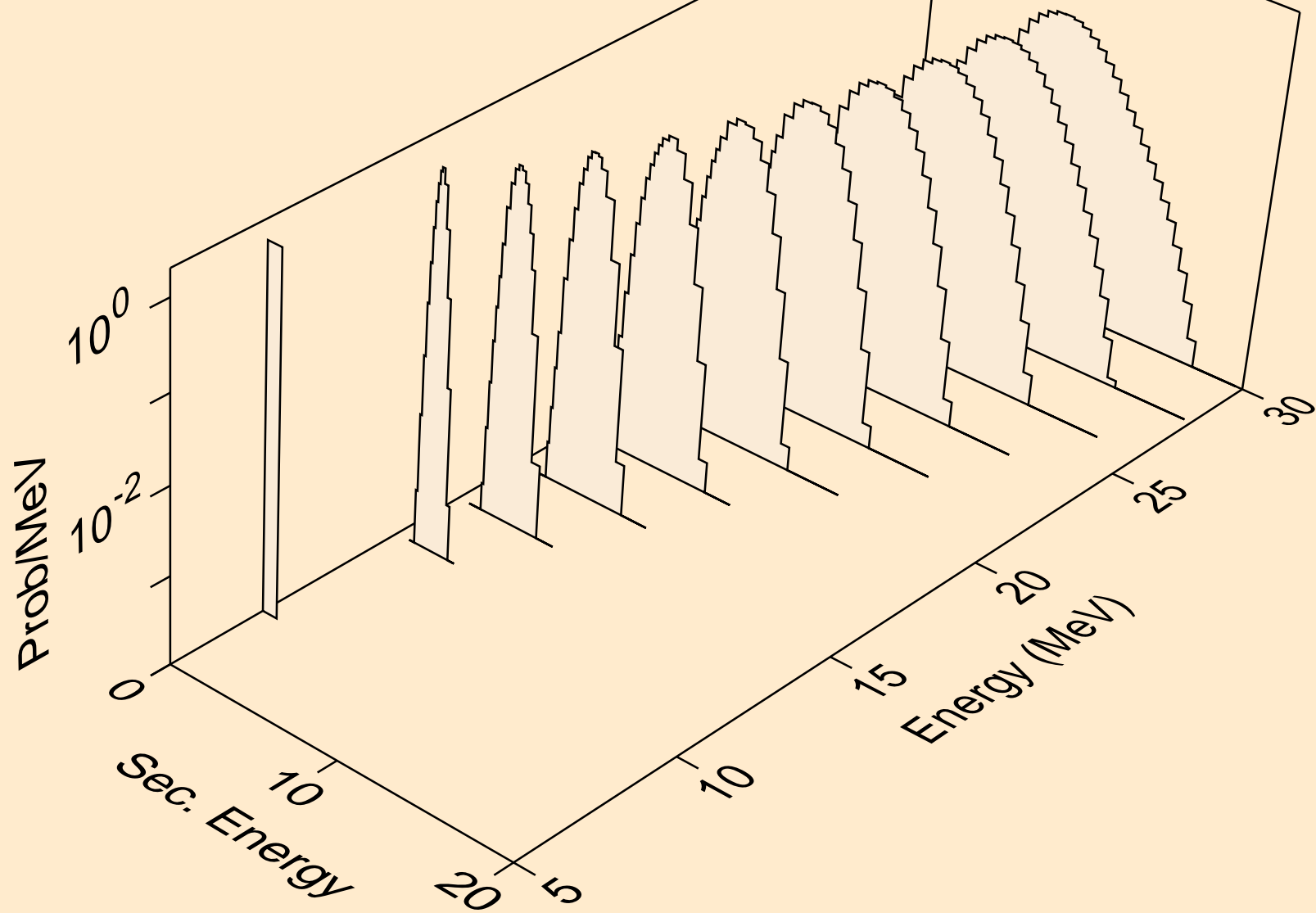

TM158 NEUTRON ACER TENDL-2024 LIBRARY; T=293.6K
protons from (n,npa)

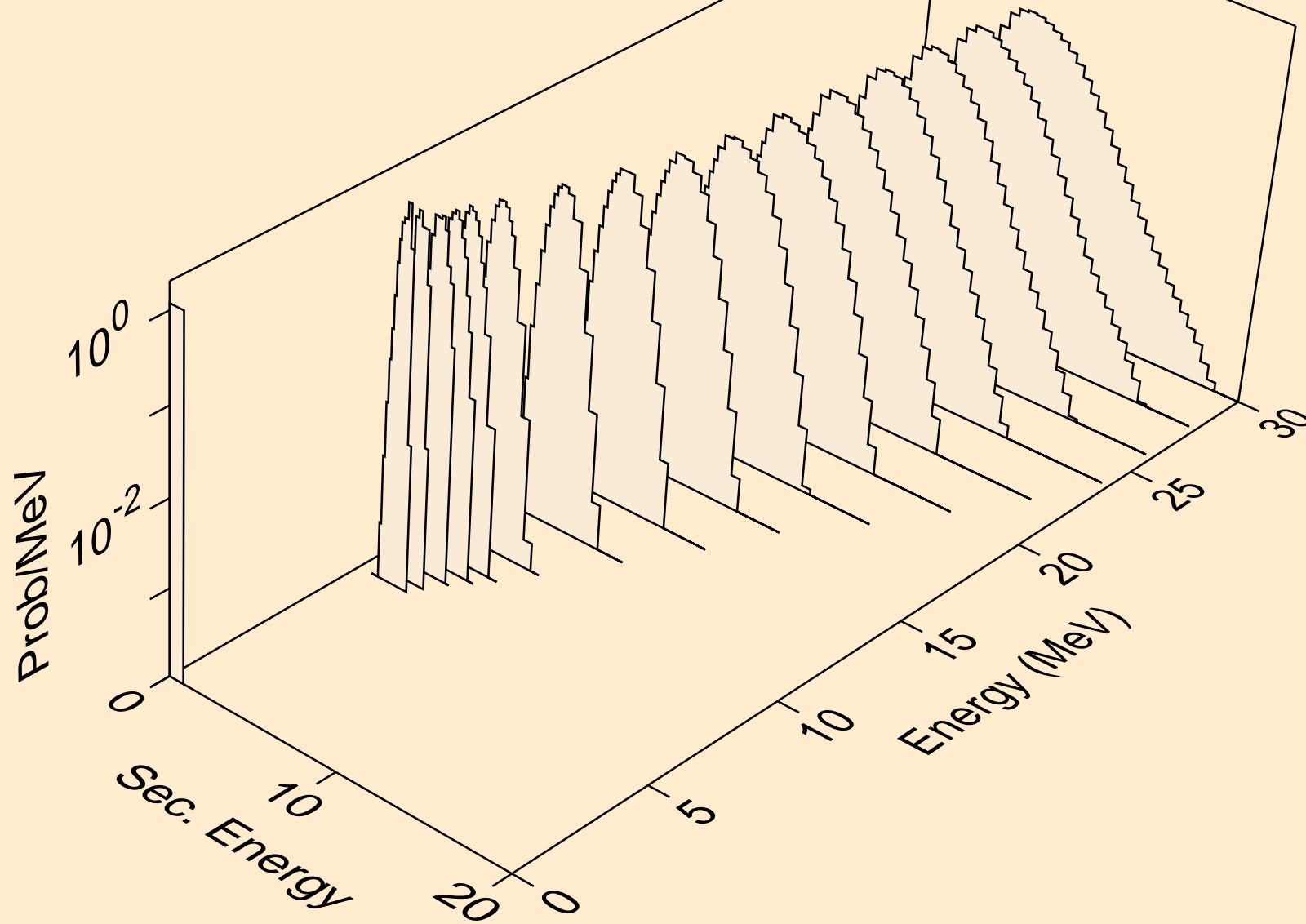

TM158 NEUTRON ACER TENDL-2024 LIBRARY; T=293.6K
protons from (n,p)

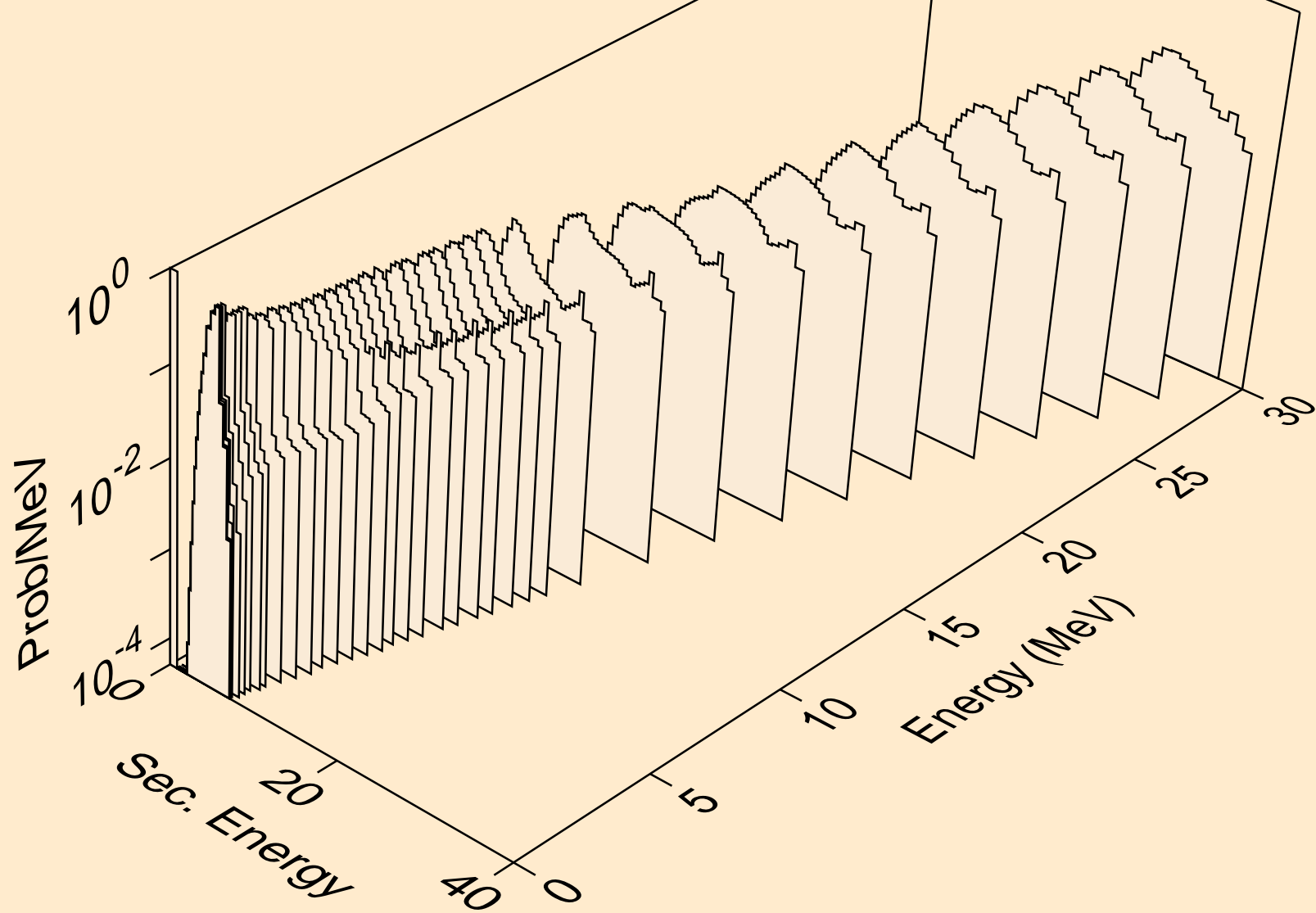

TM158 NEUTRON ACER TENDL-2024 LIBRARY; T=293.6K
protons from (n,2p)

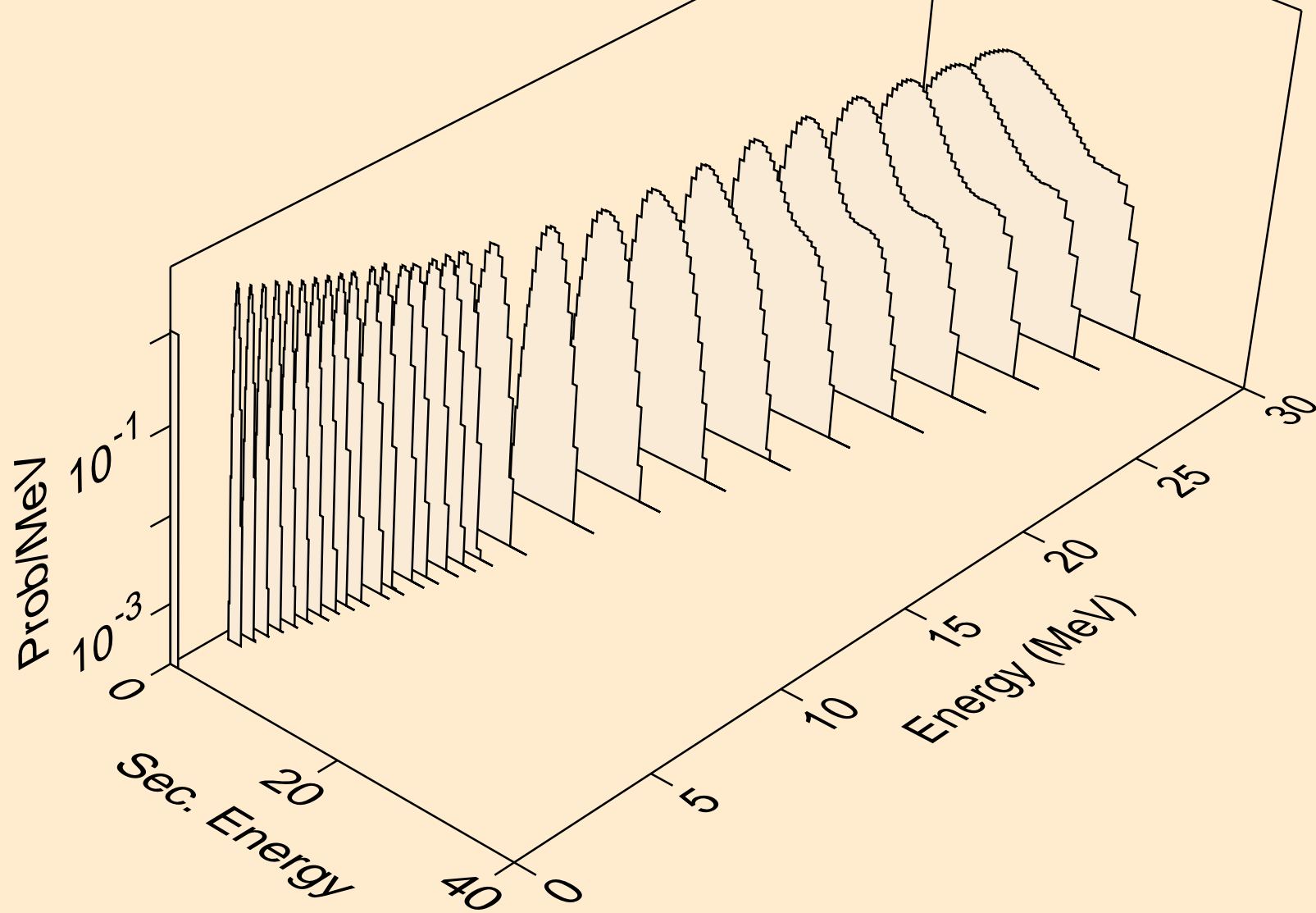

TM158 NEUTRON ACER TENDL-2024 LIBRARY; T=293.6K
protons from (n,p)

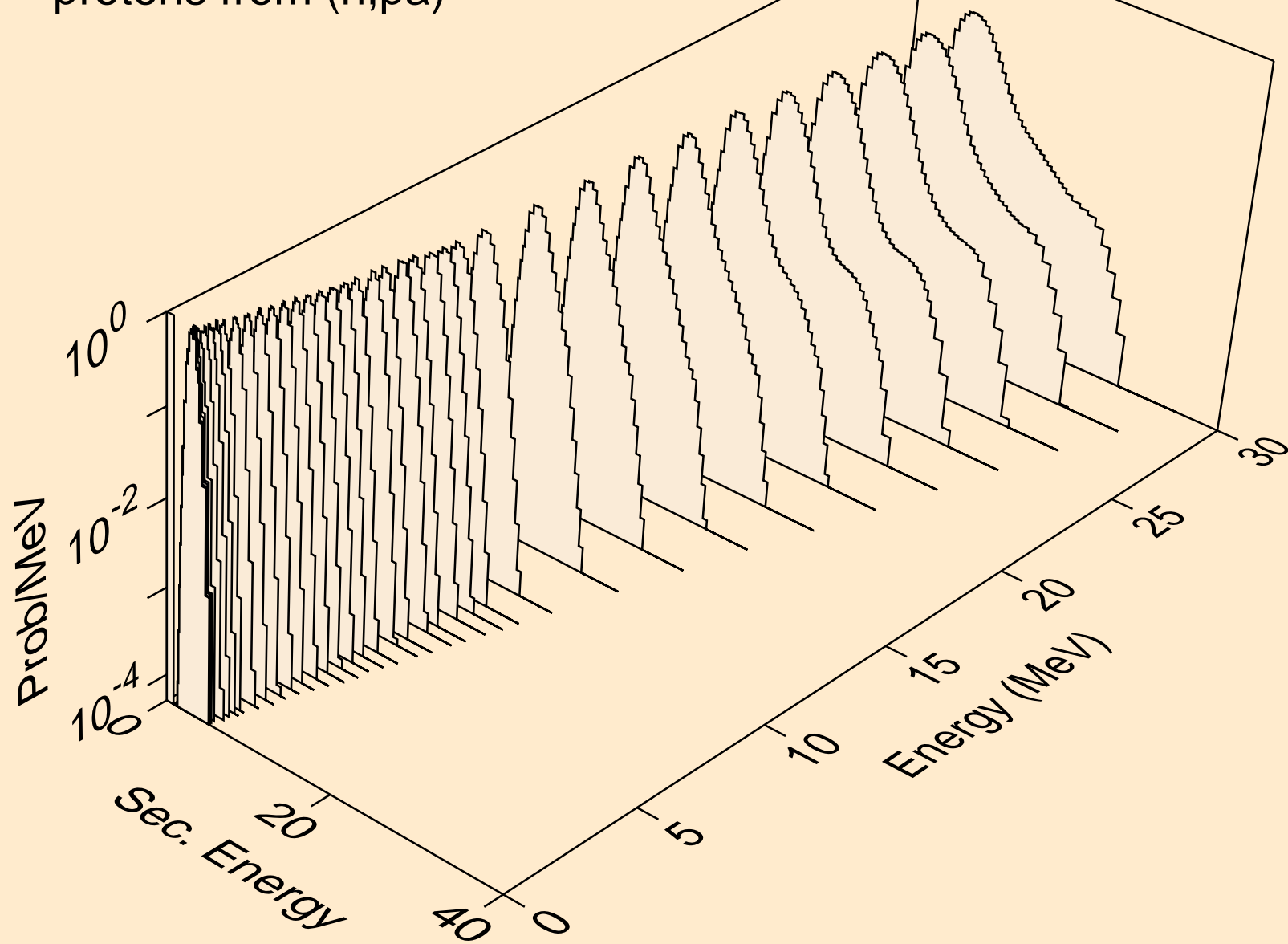

TM158 NEUTRON ACER TENDL-2024 LIBRARY; T=293.6K
protons from (n,pd)

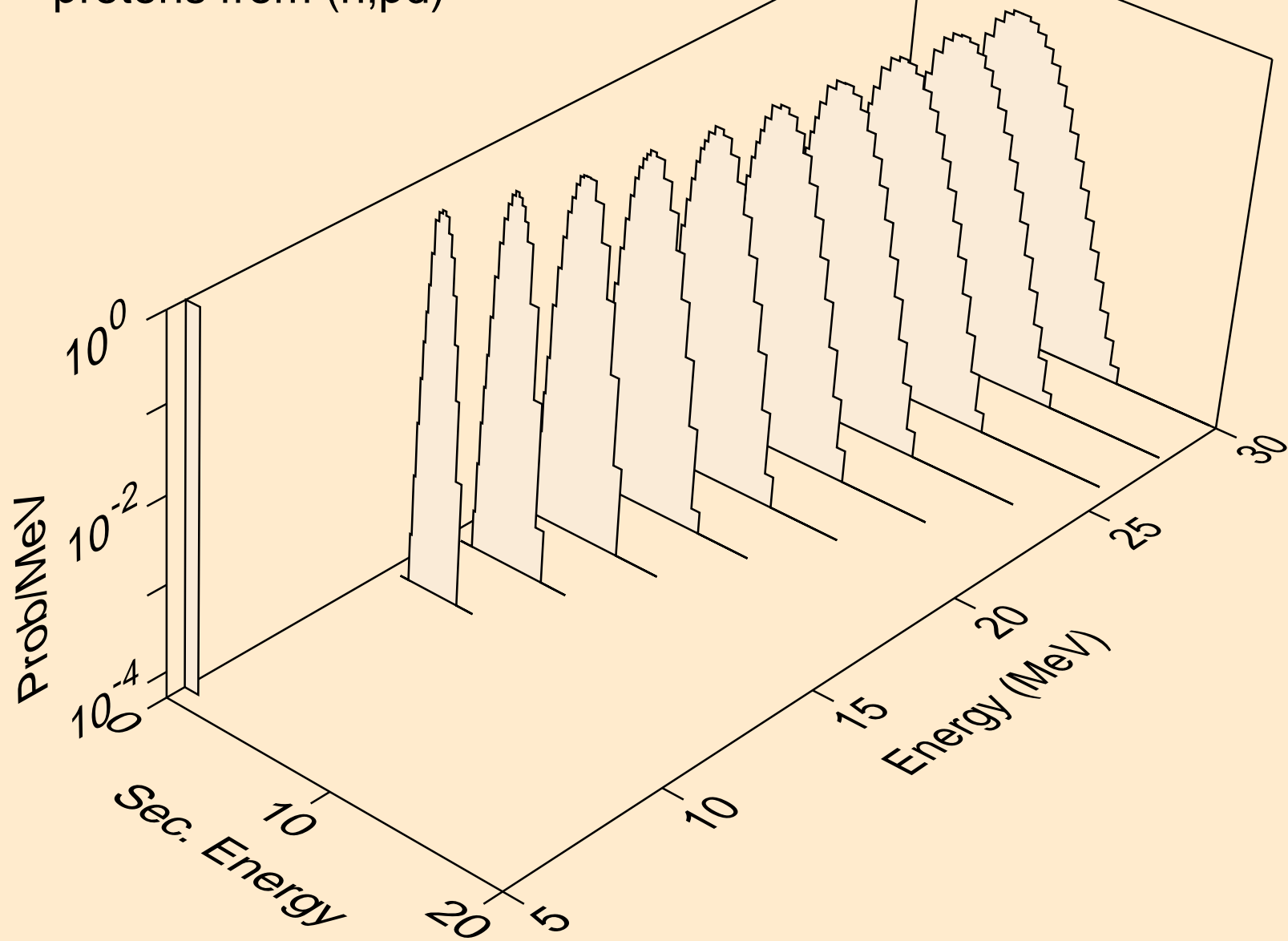

TM158 NEUTRON ACER TENDL-2024 LIBRARY; T=293.6K
protons from (n,pt)

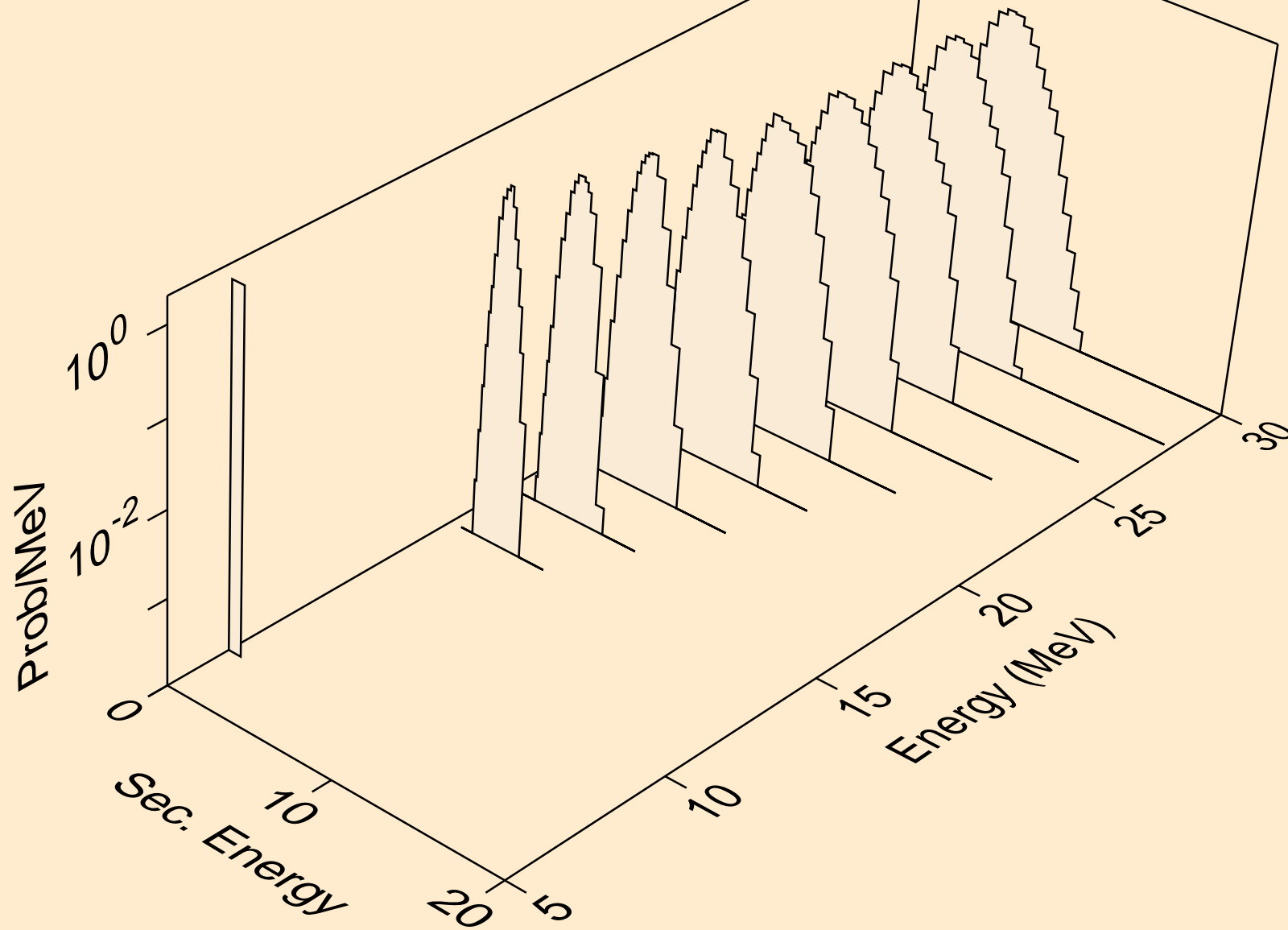

TM158 NEUTRON ACER TENDL-2024 LIBRARY; T=293.6K
deuterons from (n,x)

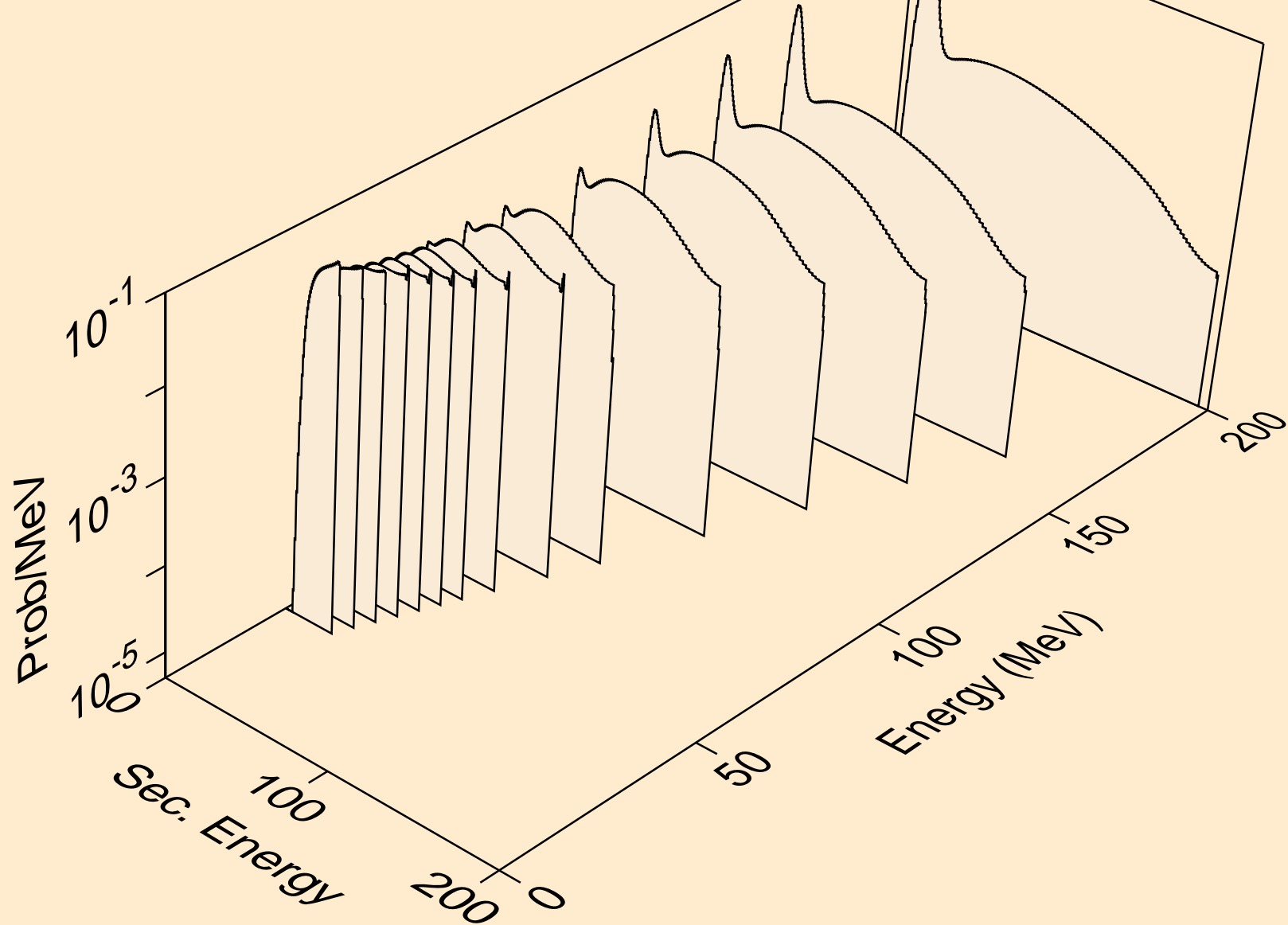

TM158 NEUTRON ACER TENDL-2024 LIBRARY; T=293.6K
deuterons from (n,2nd)

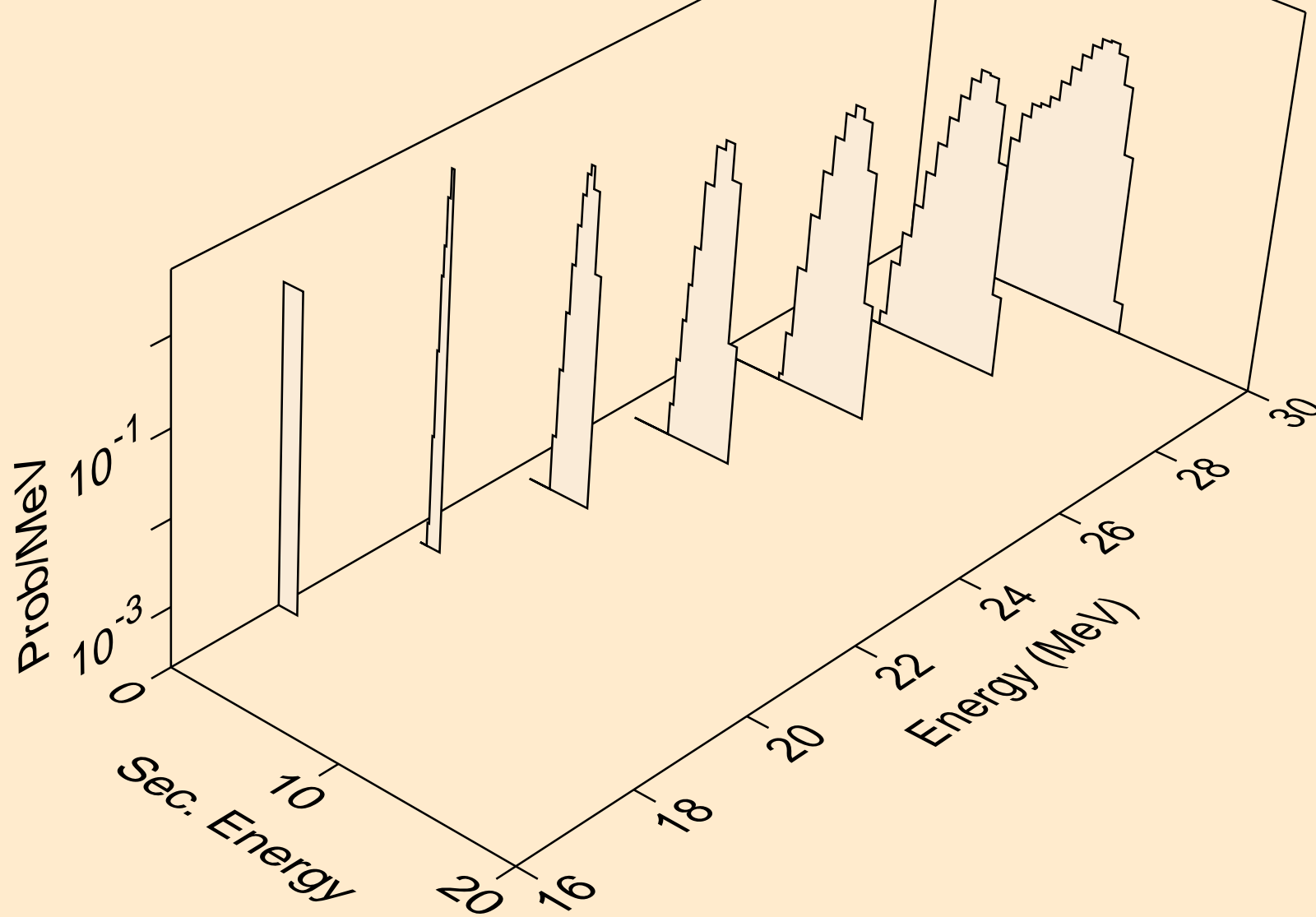

TM158 NEUTRON ACER TENDL-2024 LIBRARY; T=293.6K
deuterons from (n,n*)d

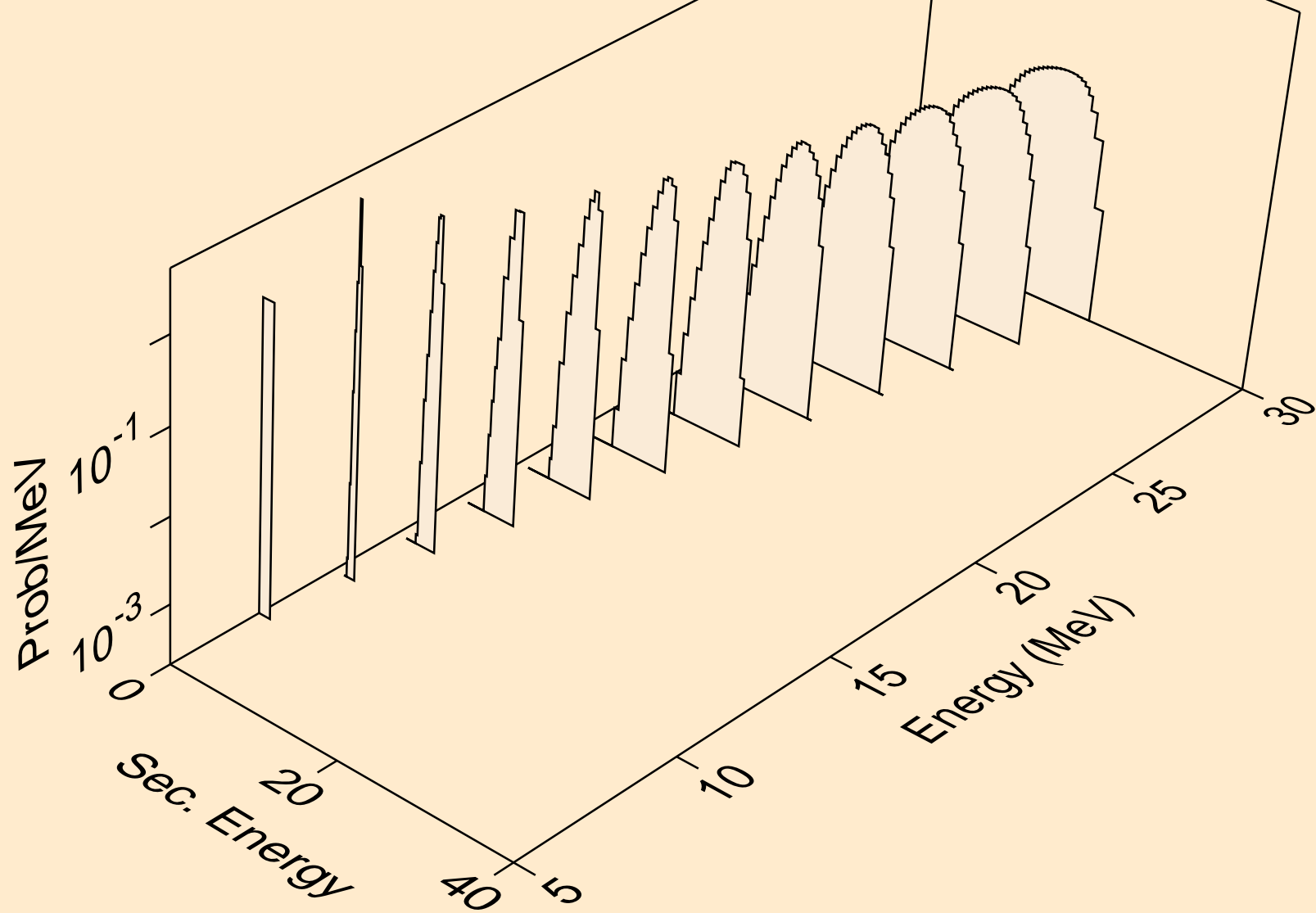

TM158 NEUTRON ACER TENDL-2024 LIBRARY; T=293.6K
deuterons from (n,d)

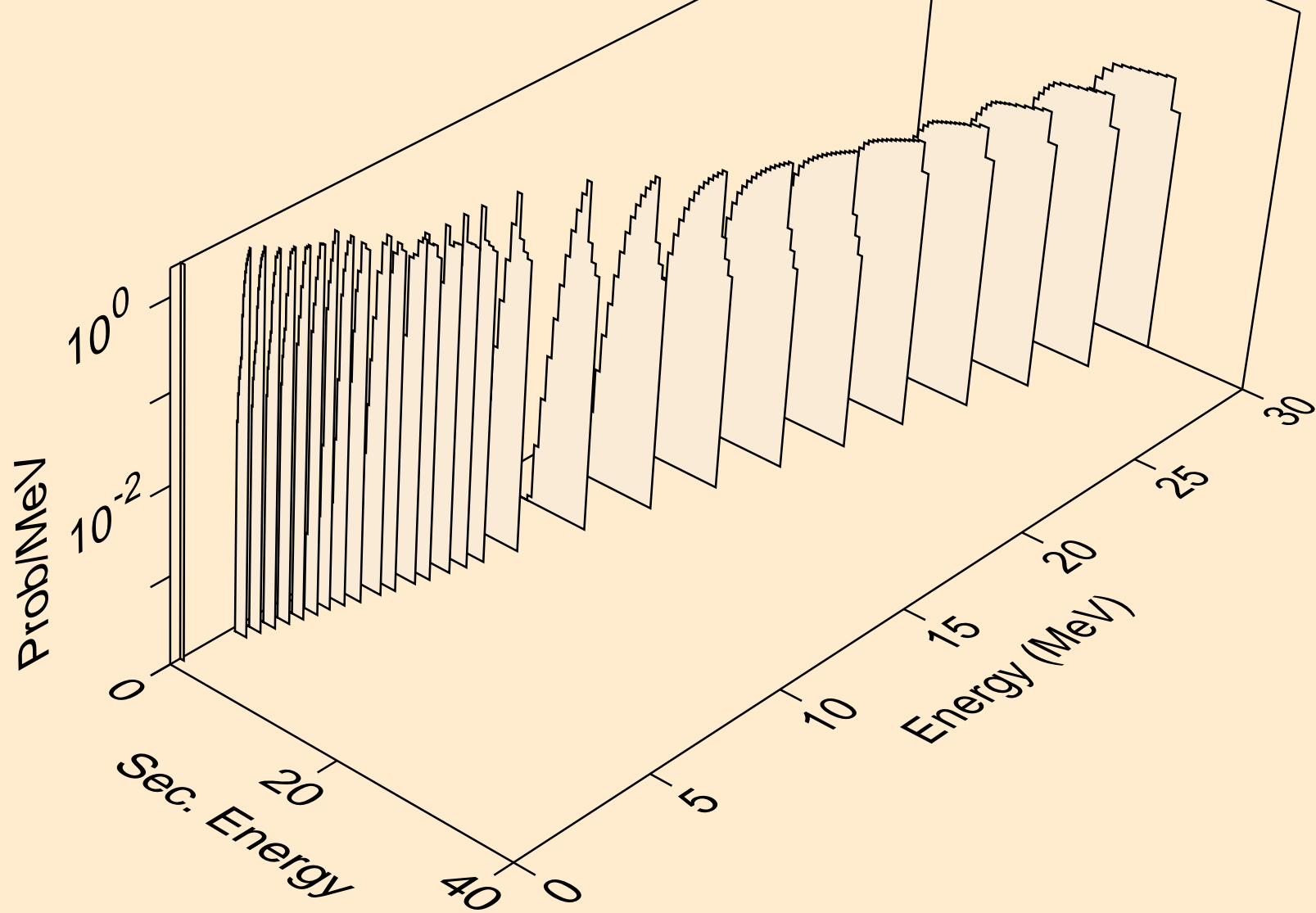

TM158 NEUTRON ACER TENDL-2024 LIBRARY; T=293.6K
deuterons from (n,pd)

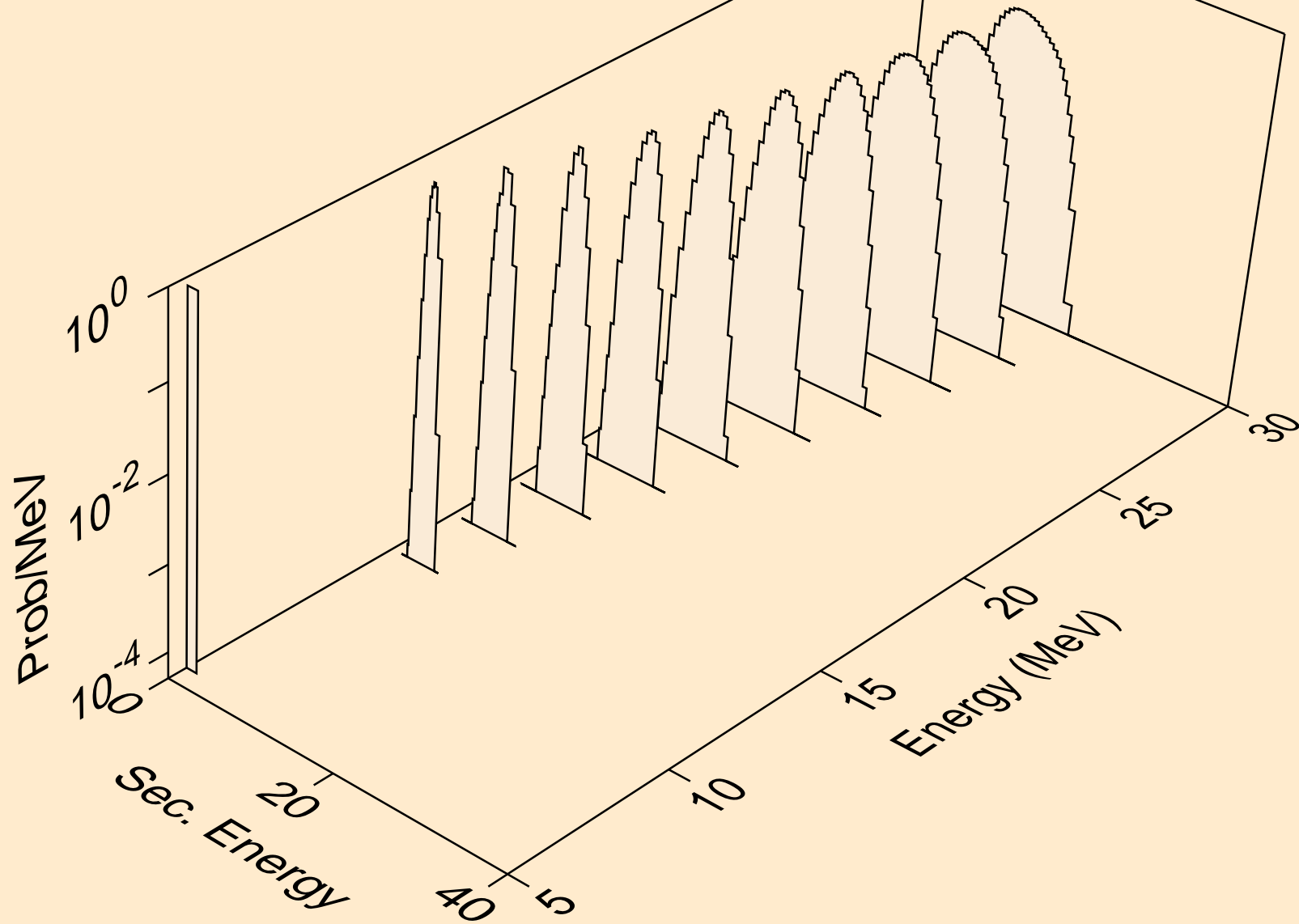

TM158 NEUTRON ACER TENDL-2024 LIBRARY; T=293.6K
deuterons from (n,da)

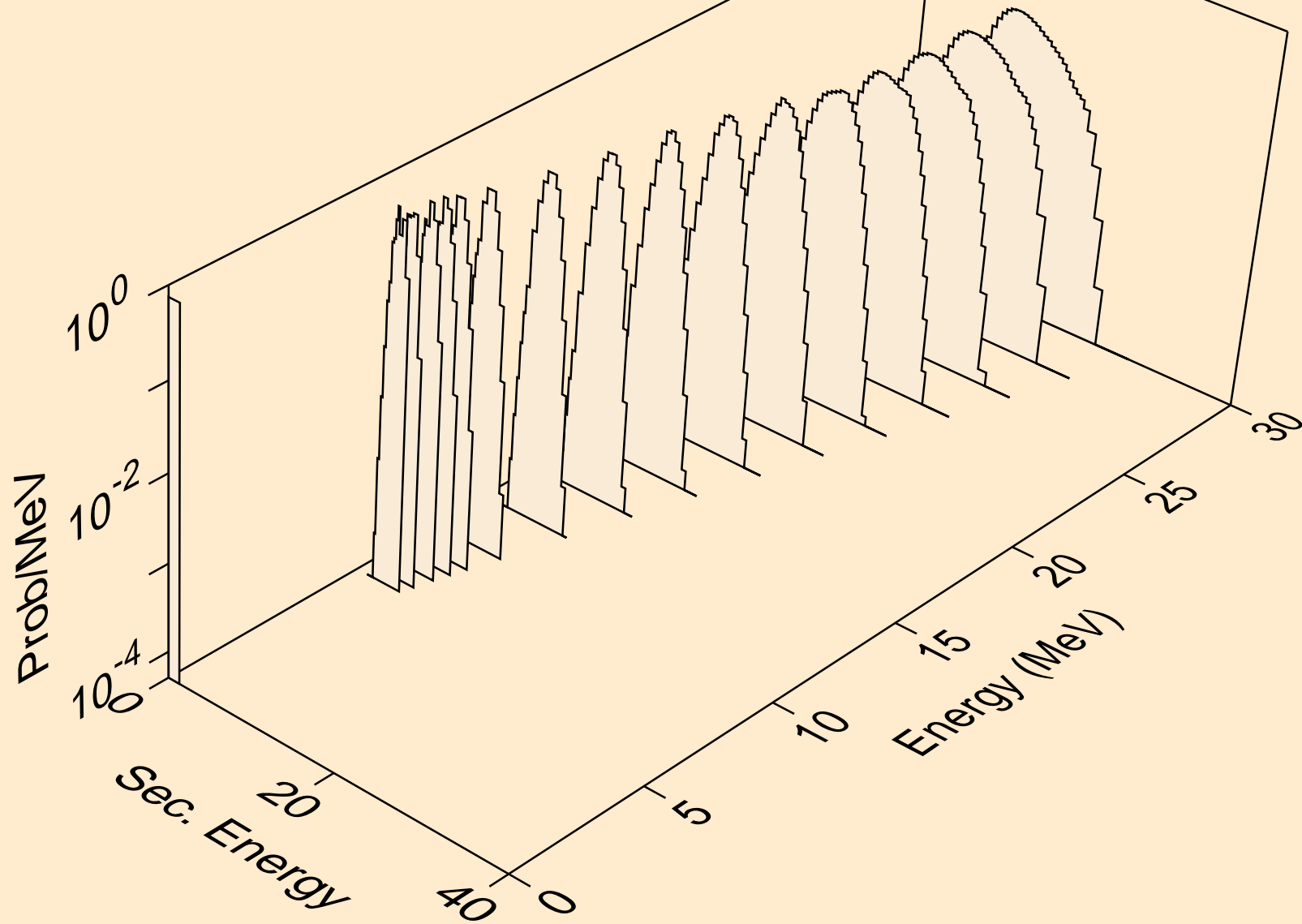

TM158 NEUTRON ACER TENDL-2024 LIBRARY; T=293.6K
tritons from (n,x)

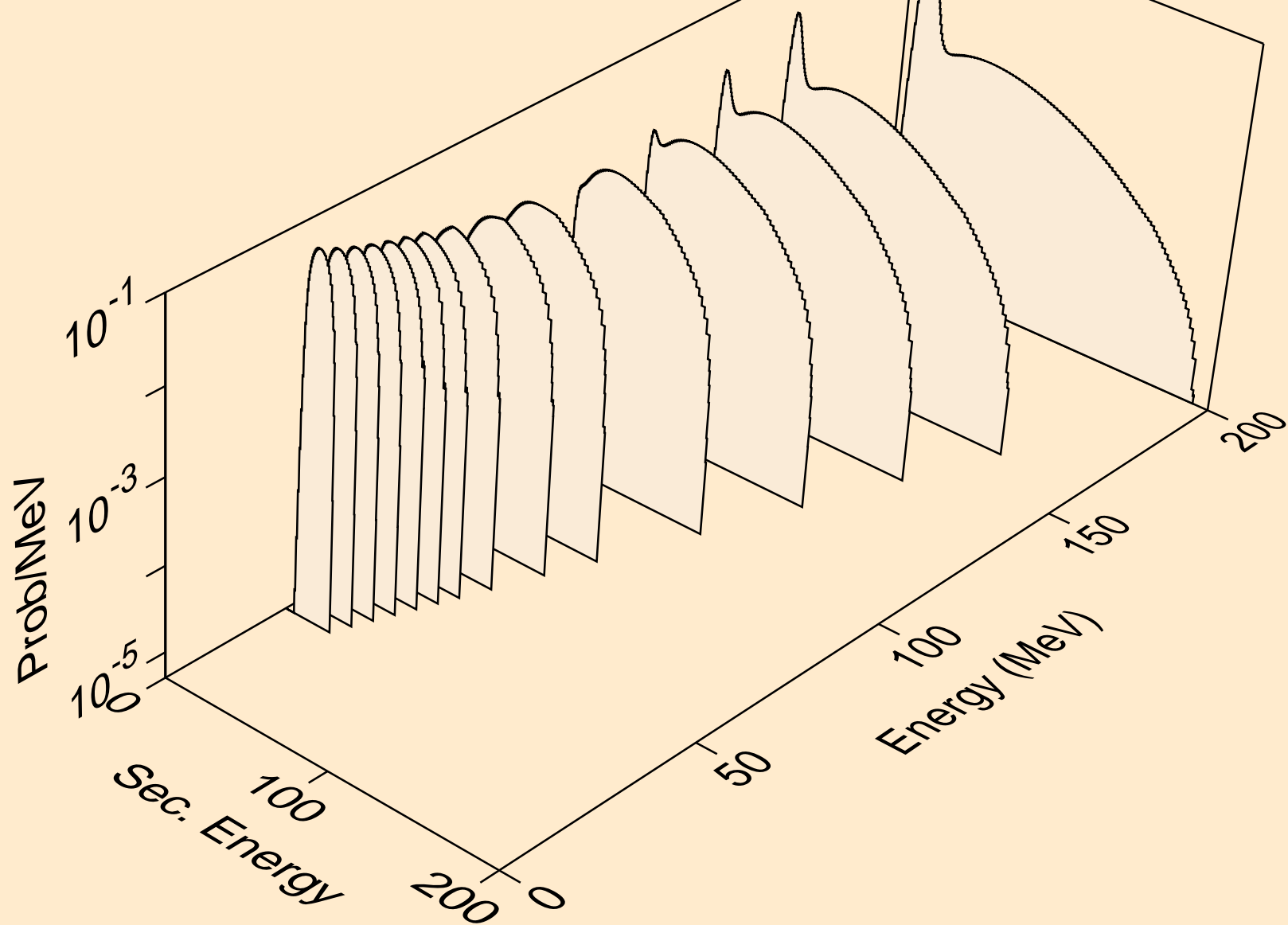

TM158 NEUTRON ACER TENDL-2024 LIBRARY; T=293.6K
tritons from (n,n*)t

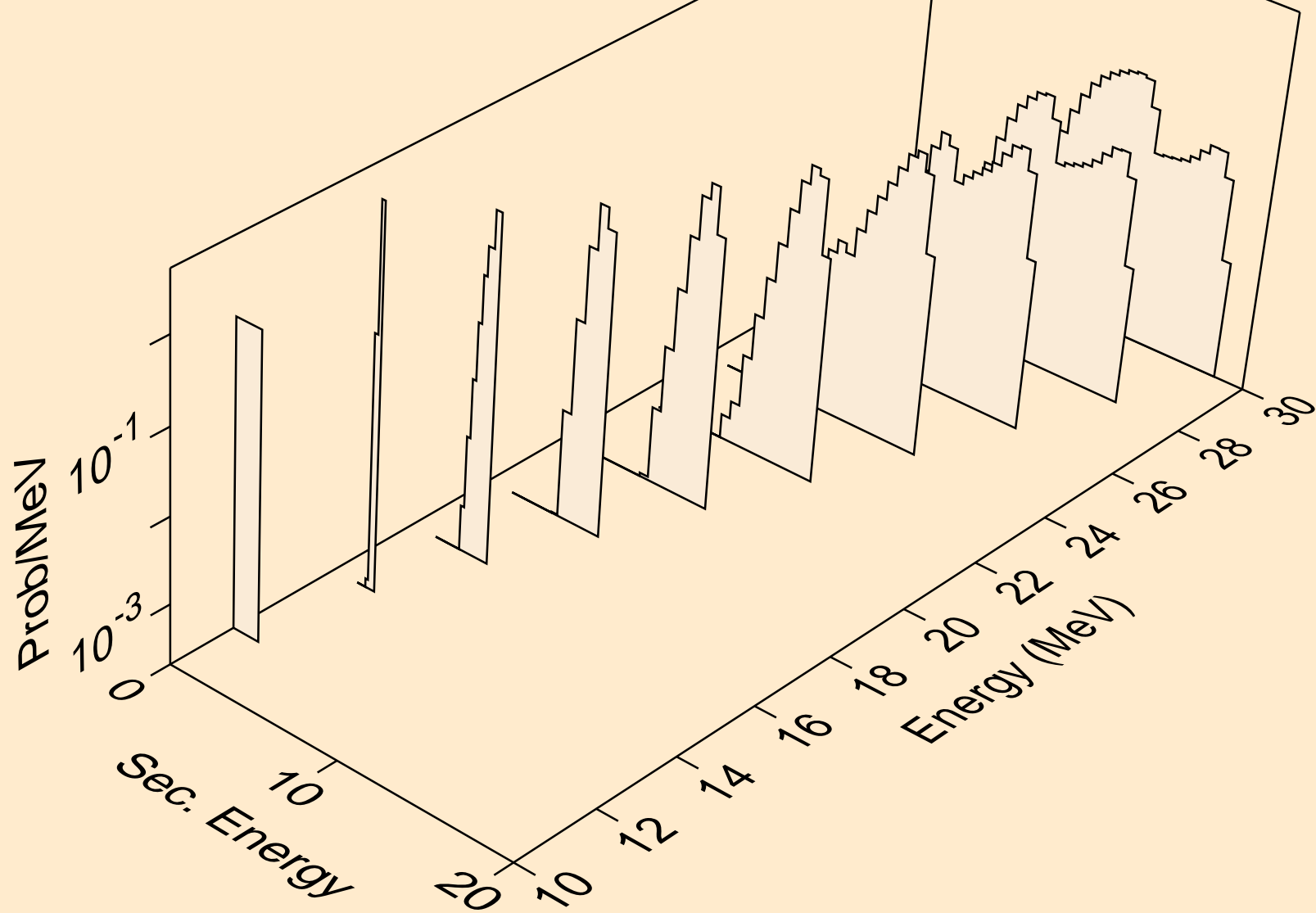

TM158 NEUTRON ACER TENDL-2024 LIBRARY; T=293.6K
tritons from (n,t)

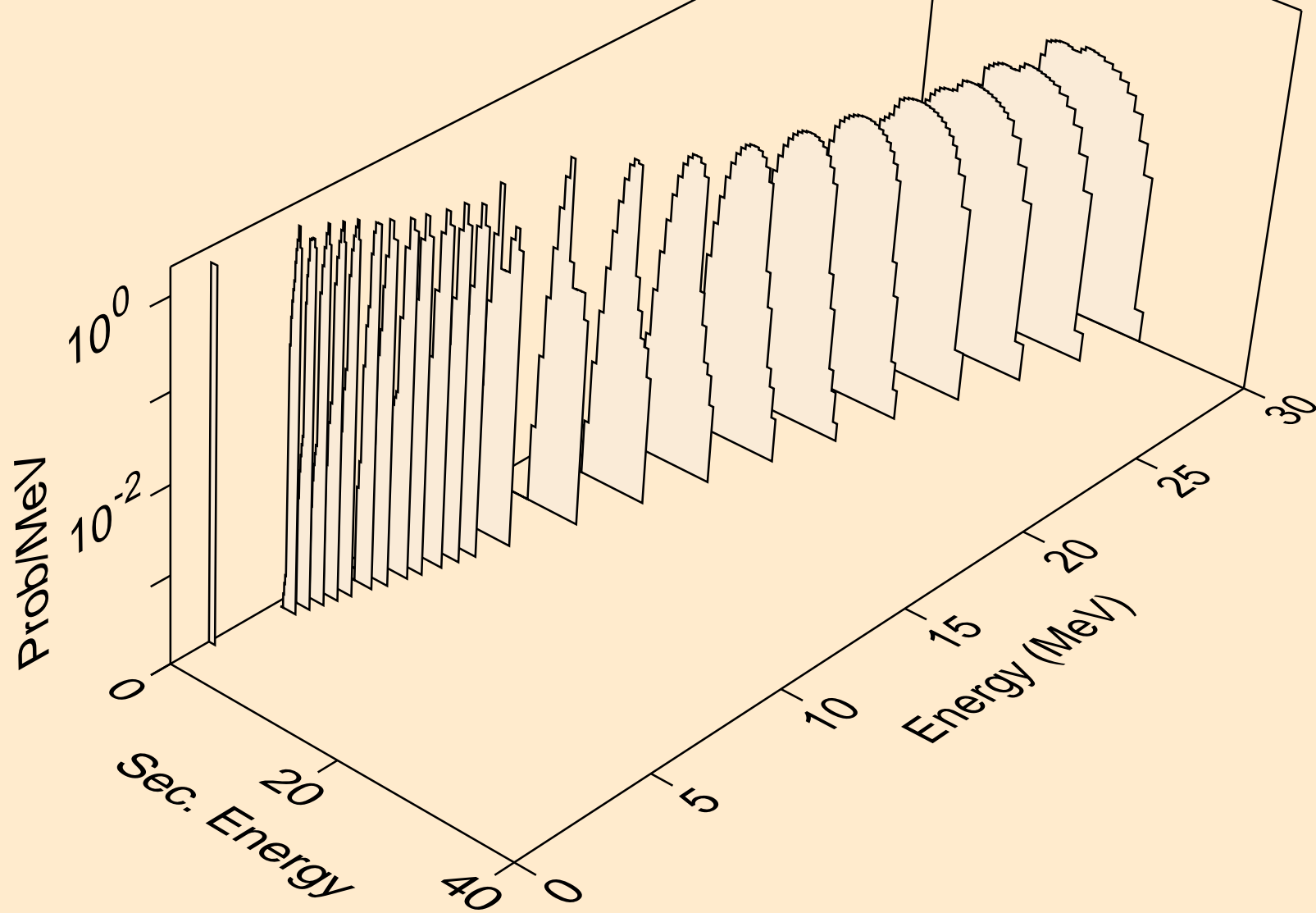

TM158 NEUTRON ACER TENDL-2024 LIBRARY; T=293.6K
tritons from (n,t2a)

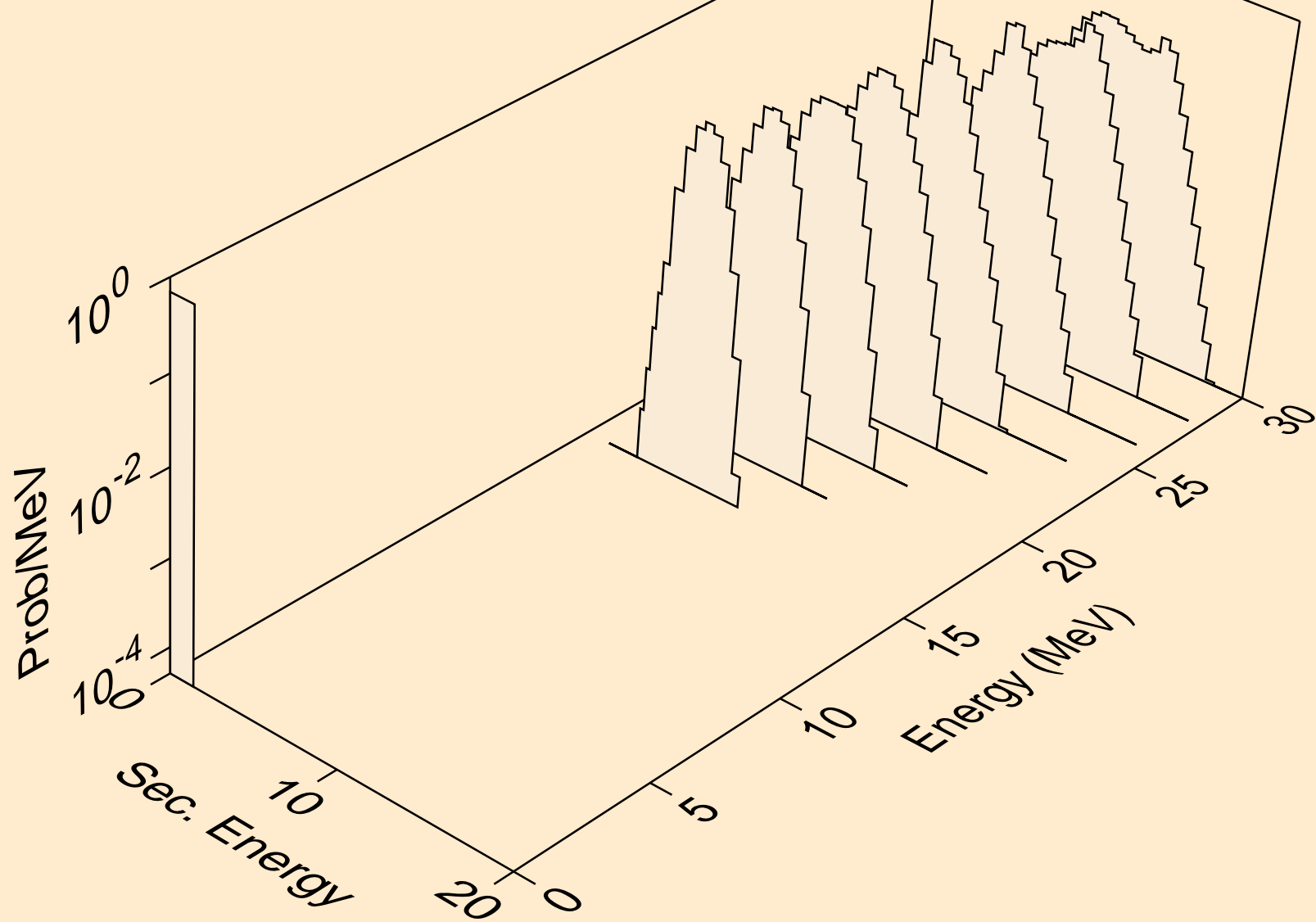

TM158 NEUTRON ACER TENDL-2024 LIBRARY; T=293.6K
tritons from (n,pt)

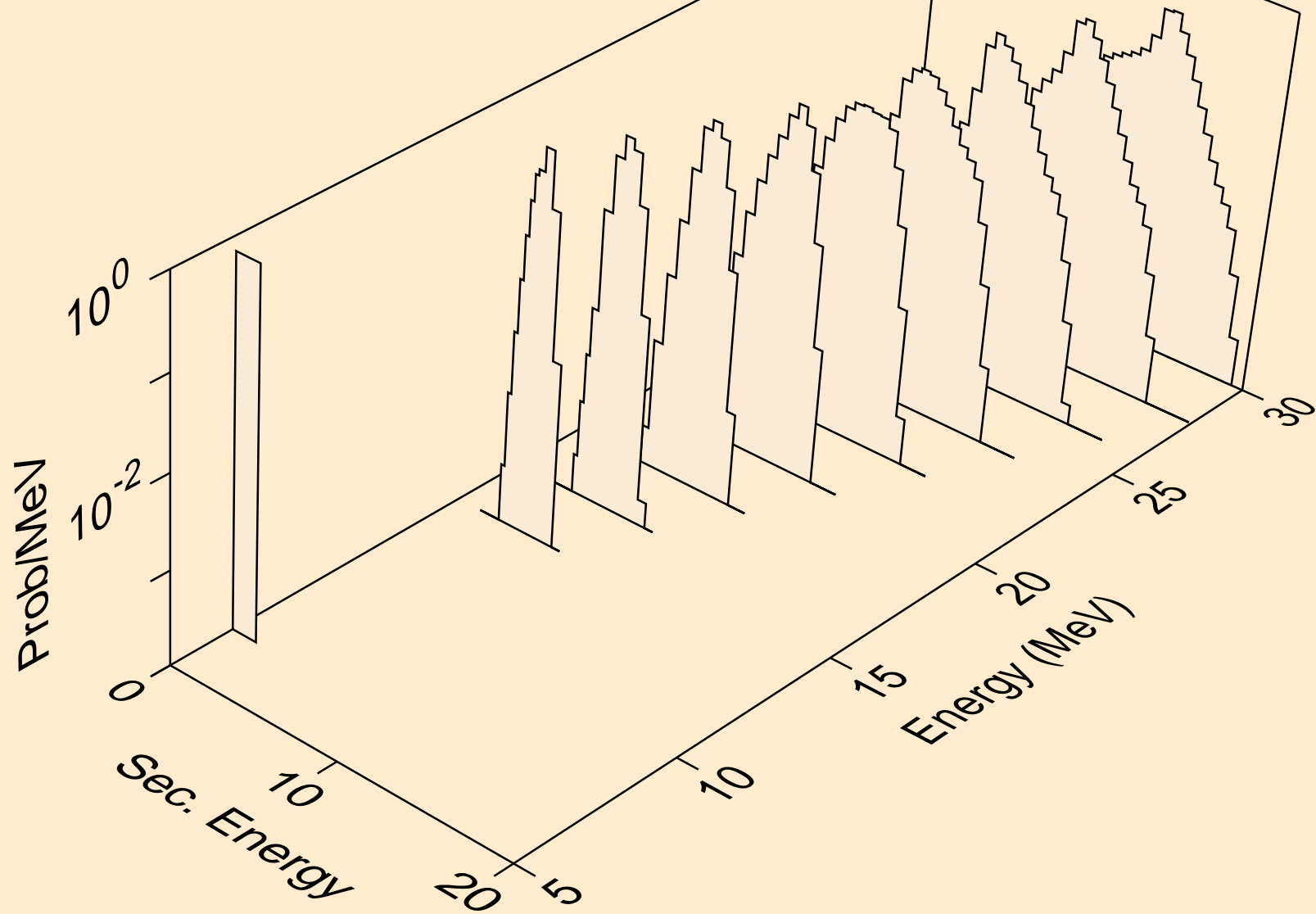

TM158 NEUTRON ACER TENDL-2024 LIBRARY; T=293.6K
he3s from (n,x)

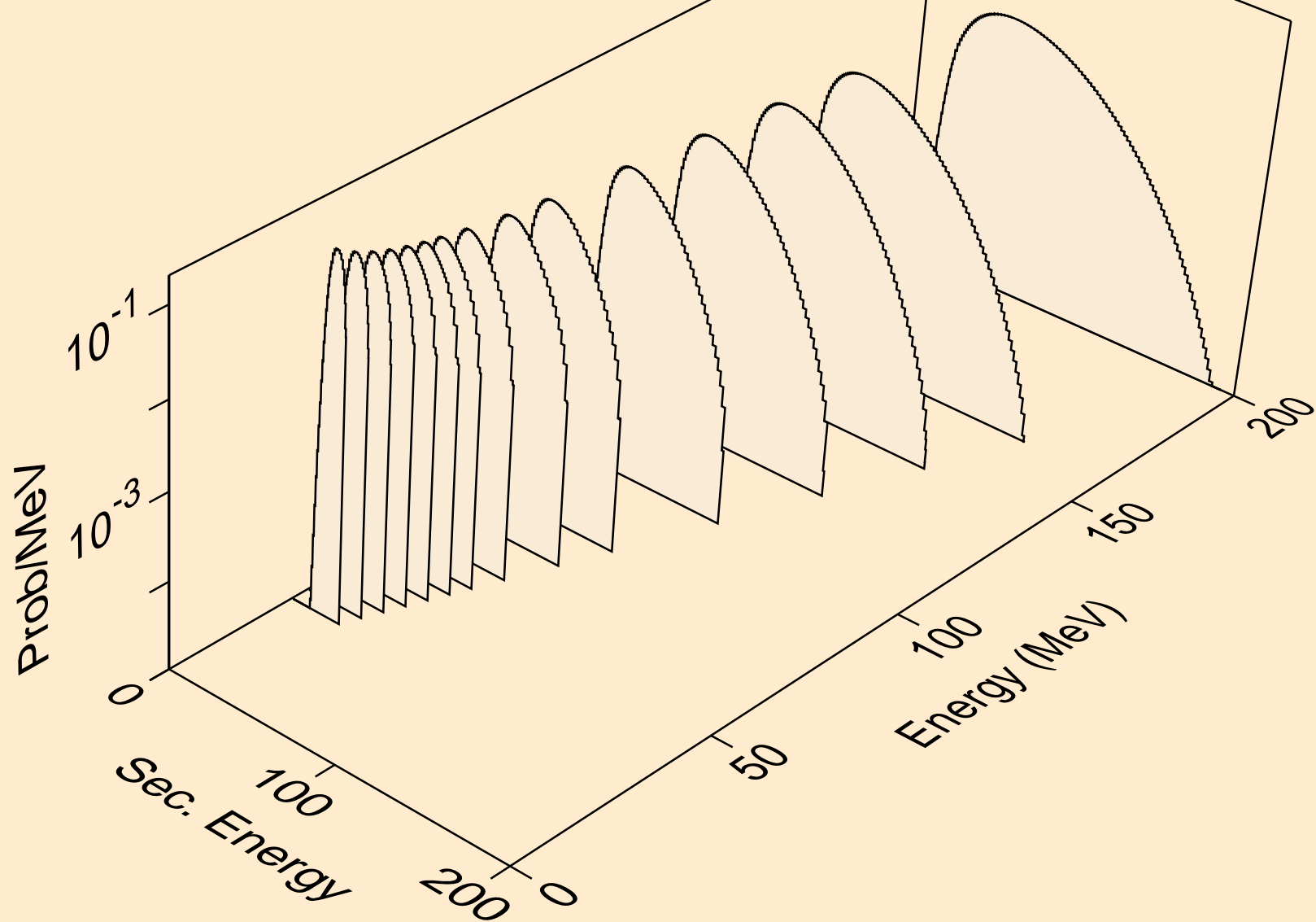

TM158 NEUTRON ACER TENDL-2024 LIBRARY; T=293.6K
he3s from (n,n*)he3

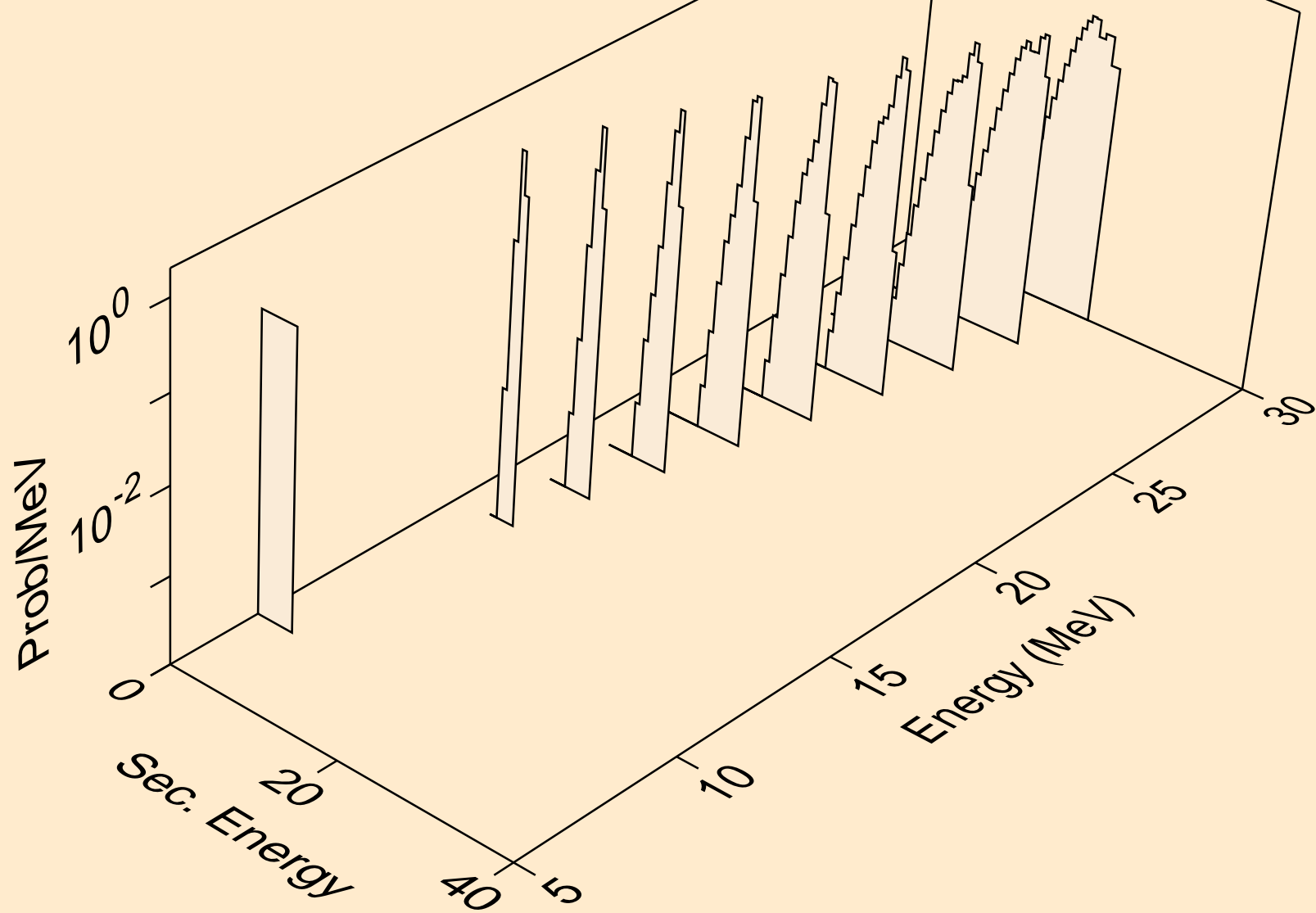

TM158 NEUTRON ACER TENDL-2024 LIBRARY; T=293.6K
he3s from (n,he3)

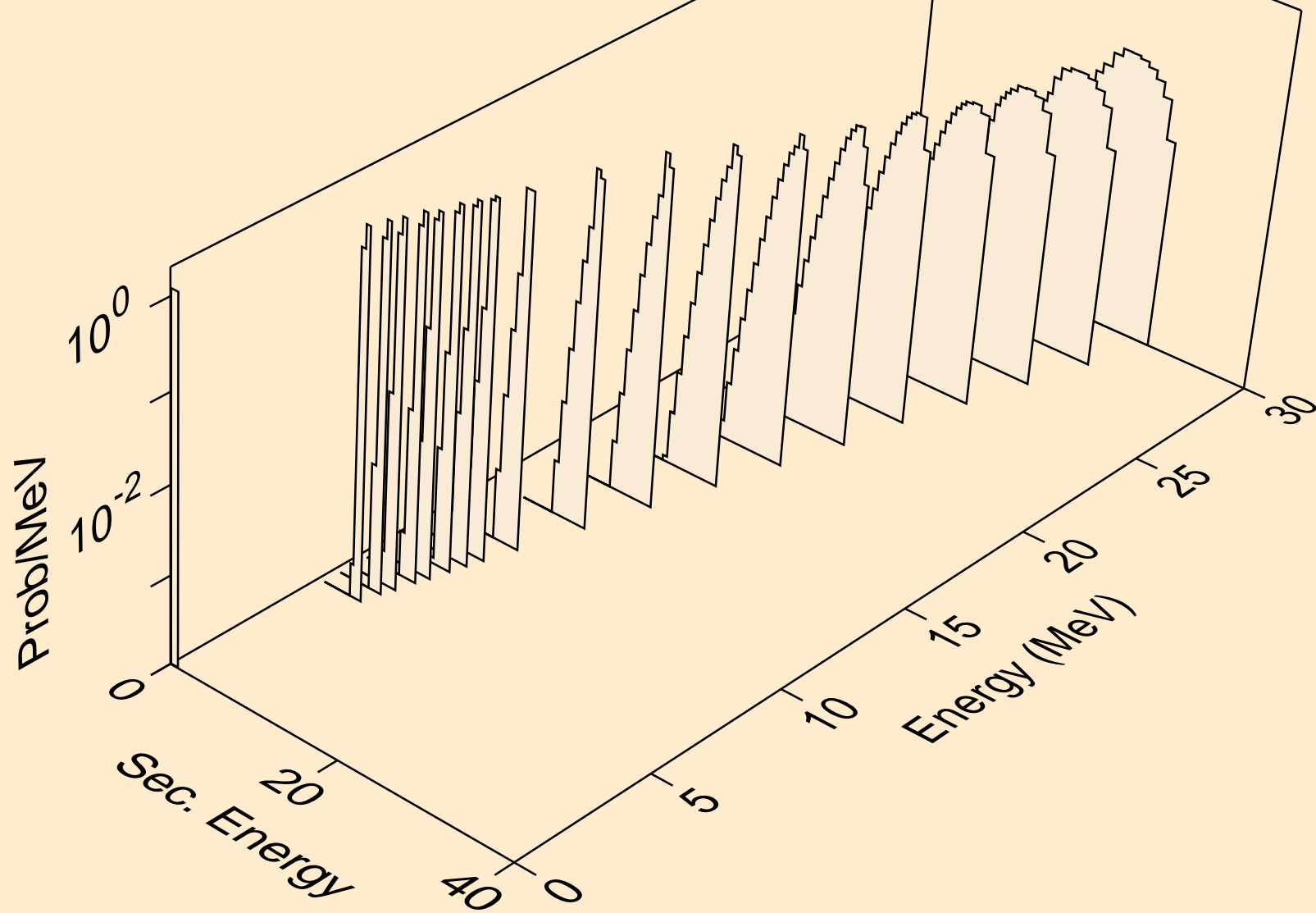

TM158 NEUTRON ACER TENDL-2024 LIBRARY; T=293.6K
alphas from (n,x)

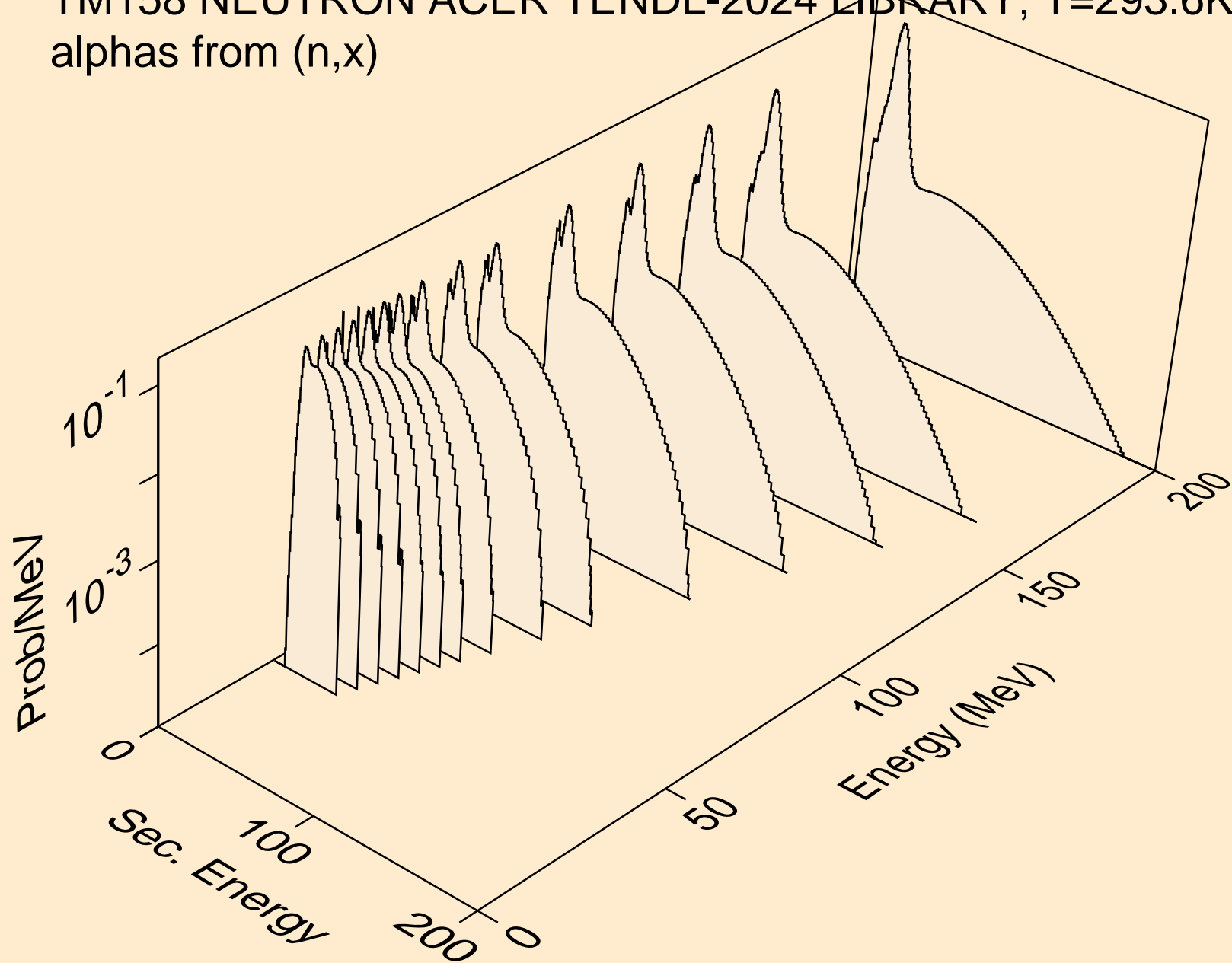

TM158 NEUTRON ACER TENDL-2024 LIBRARY; T=293.6K
alphas from (n,n*)a

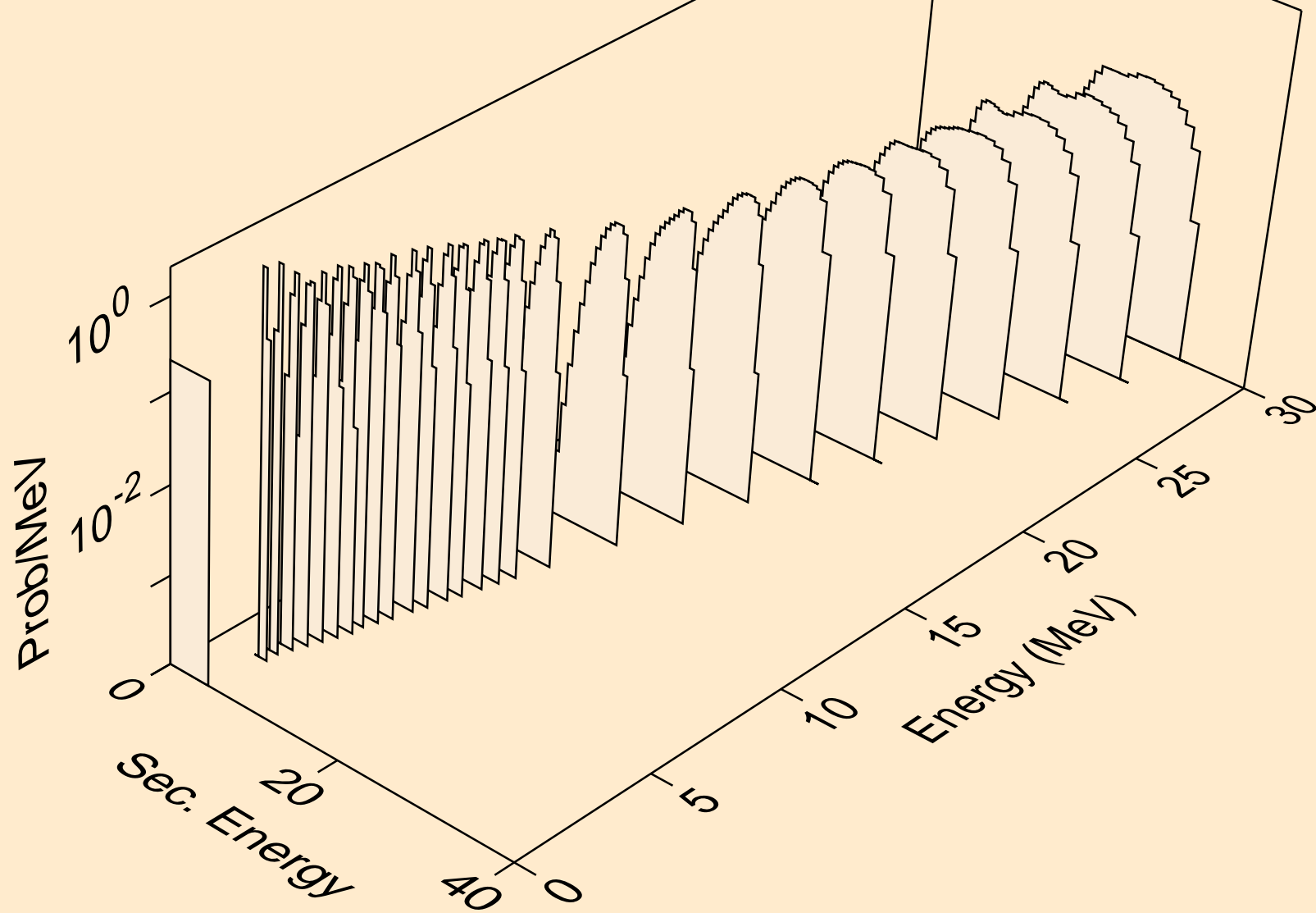

TM158 NEUTRON ACER TENDL-2024 LIBRARY; T=293.6K
alphas from (n,n*)3a

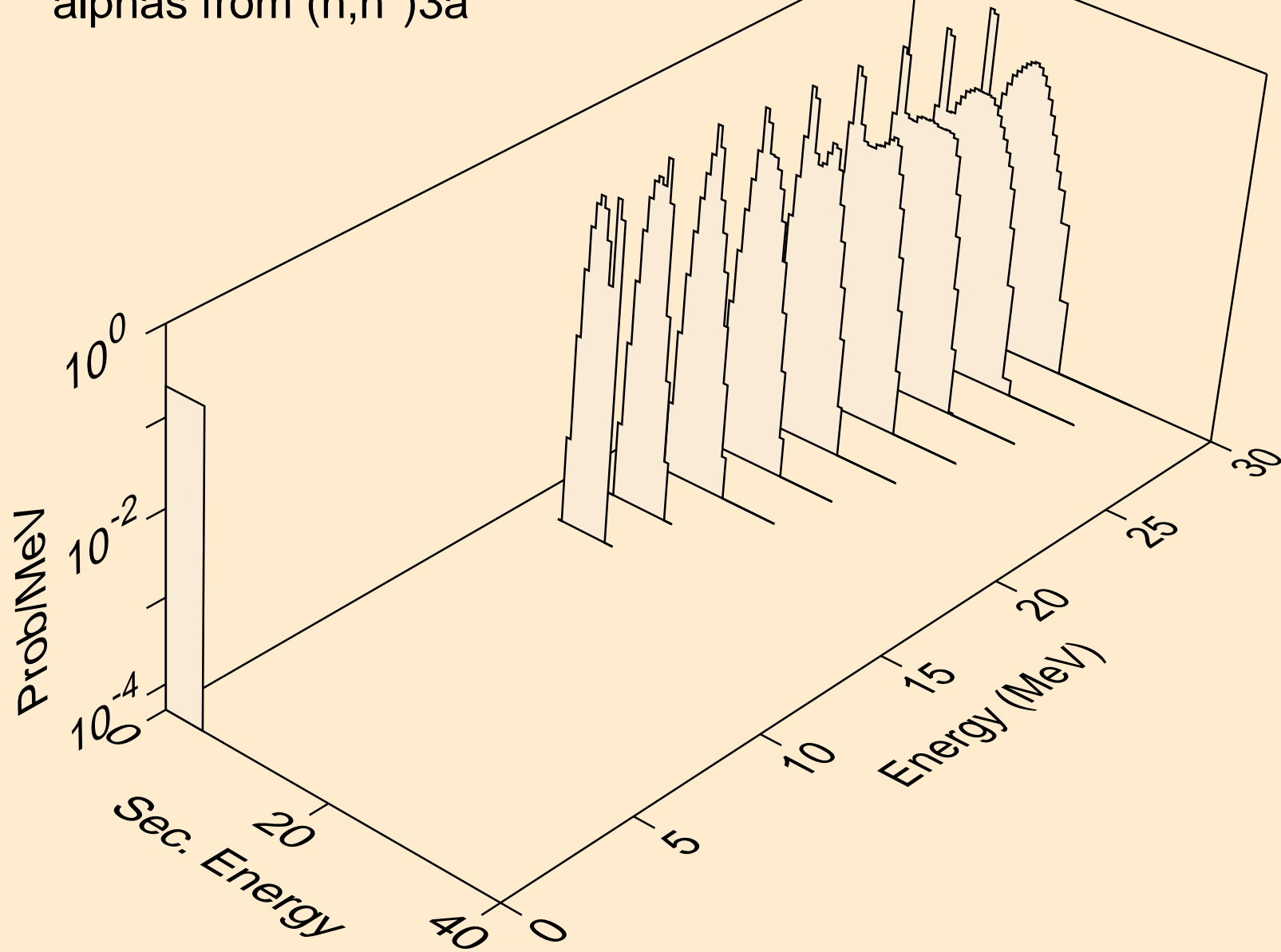

TM158 NEUTRON ACER TENDL-2024 LIBRARY; T=293.6K
alphas from (n,2n)a

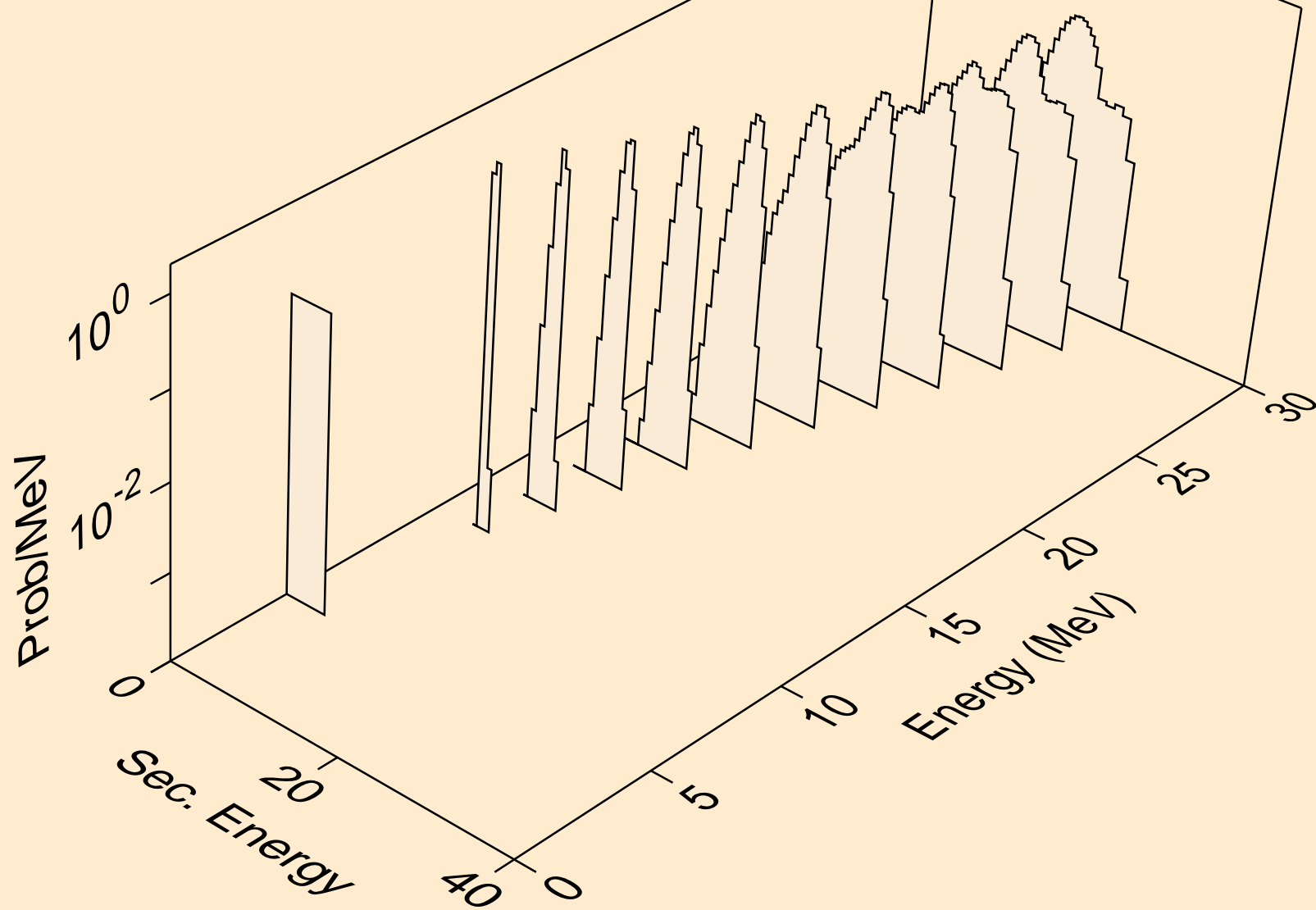

TM158 NEUTRON ACER TENDL-2024 LIBRARY; T=293.6K
alphas from (n,3n)a

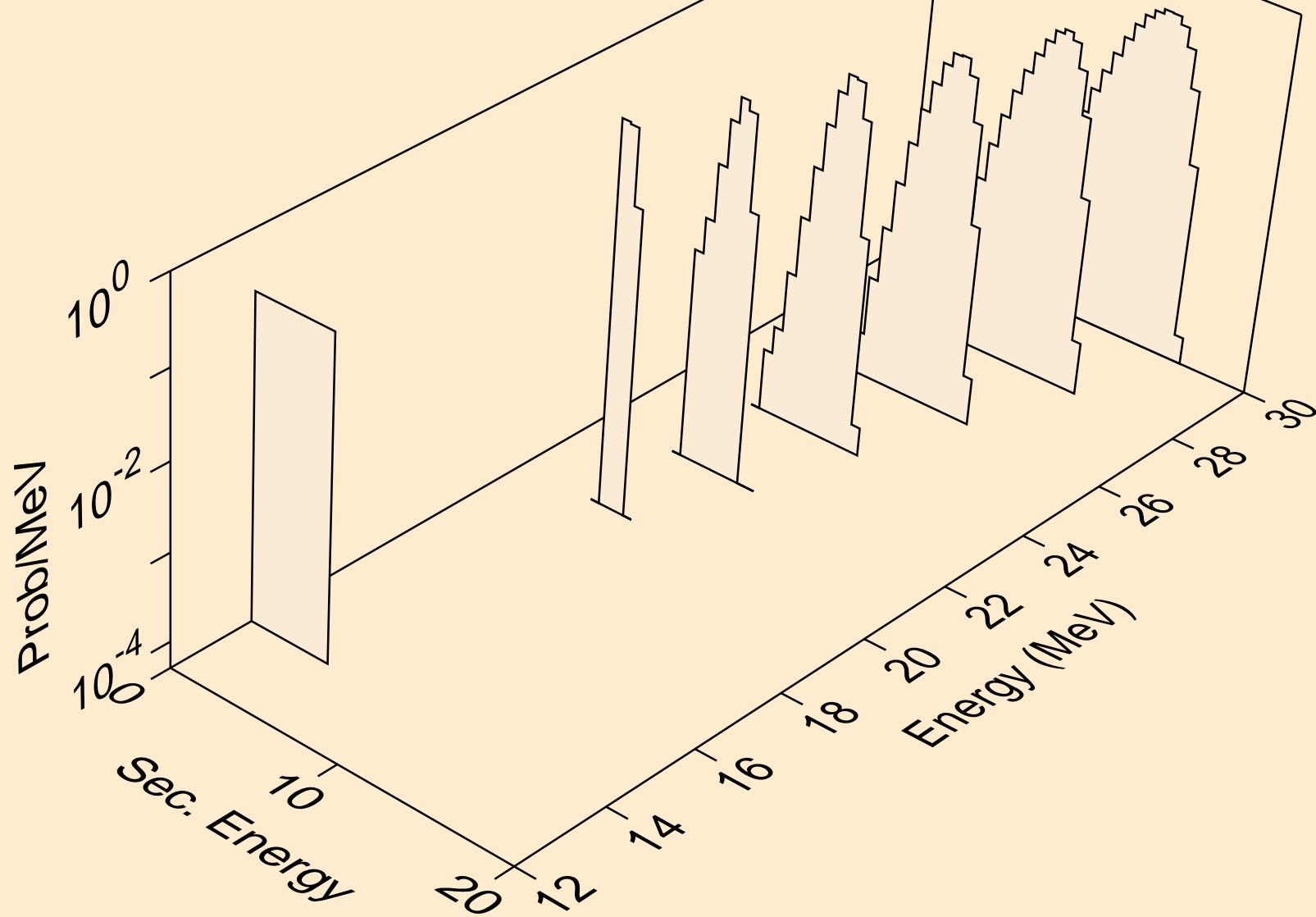

TM158 NEUTRON ACER TENDL-2024 LIBRARY; T=293.6K
alphas from (n,n*)2a

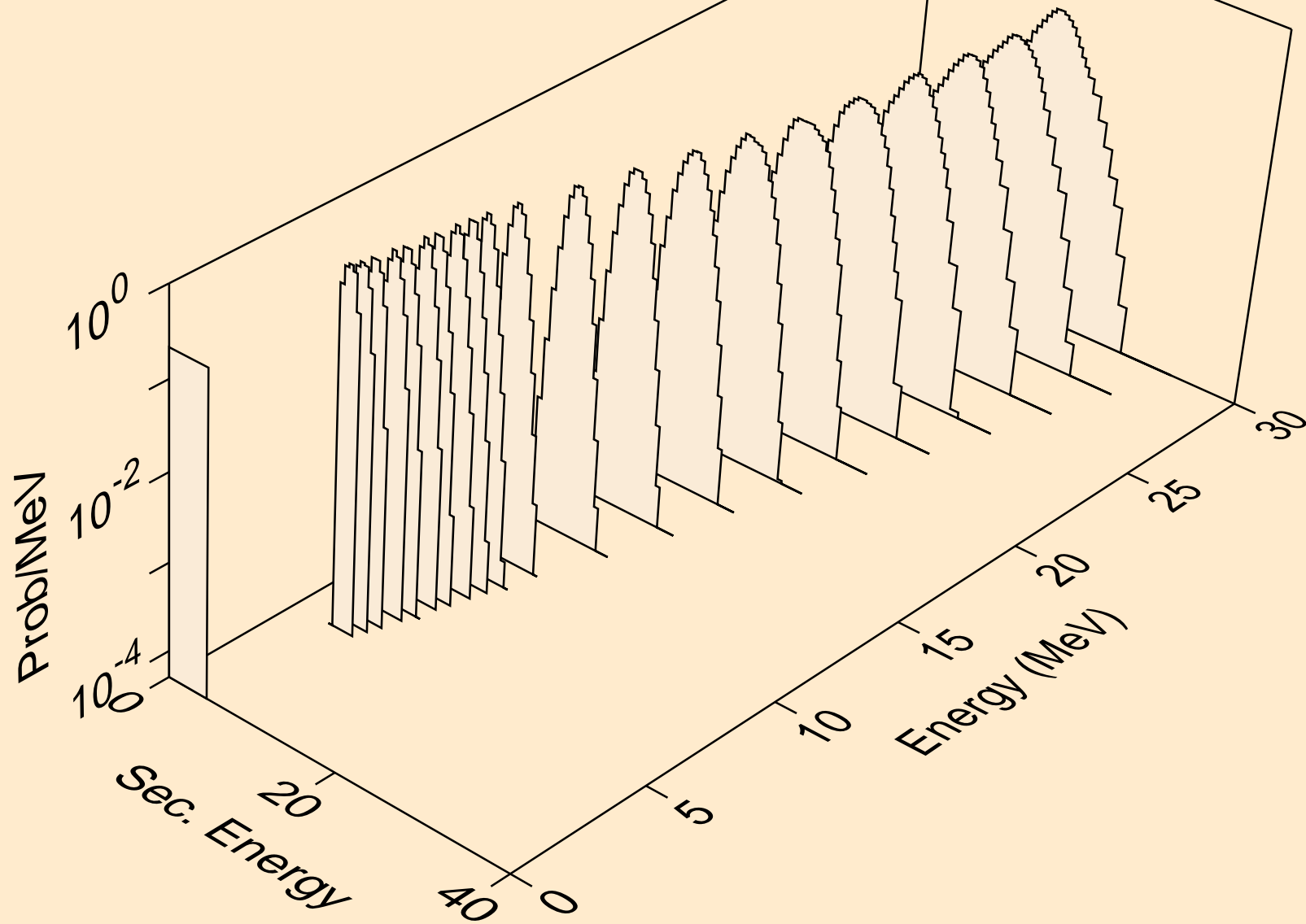

TM158 NEUTRON ACER TENDL-2024 LIBRARY; T=293.6K
alphas from (n,2n)2a

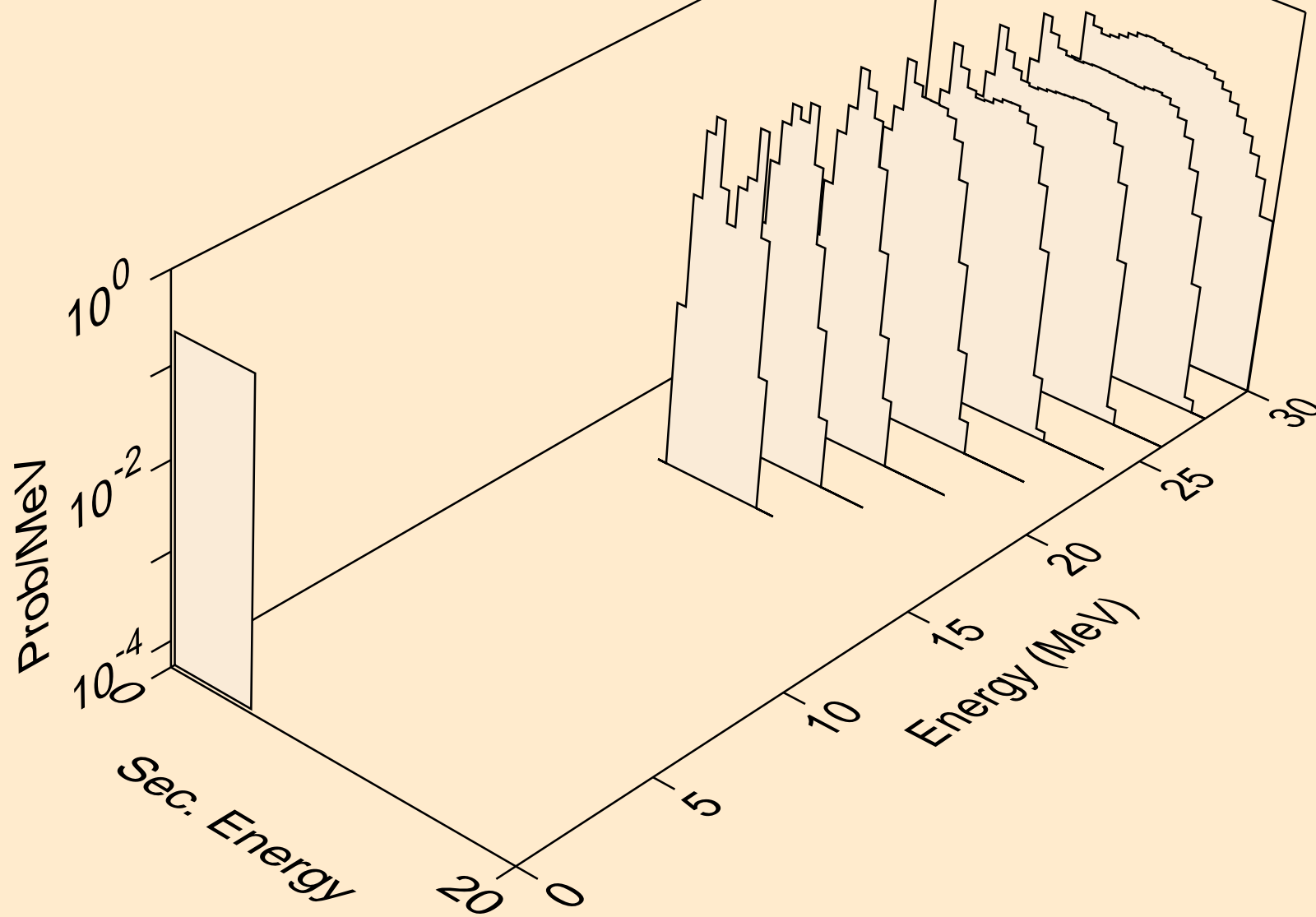

TM158 NEUTRON ACER TENDL-2024 LIBRARY; T=293.6K
alphas from (n,npa)

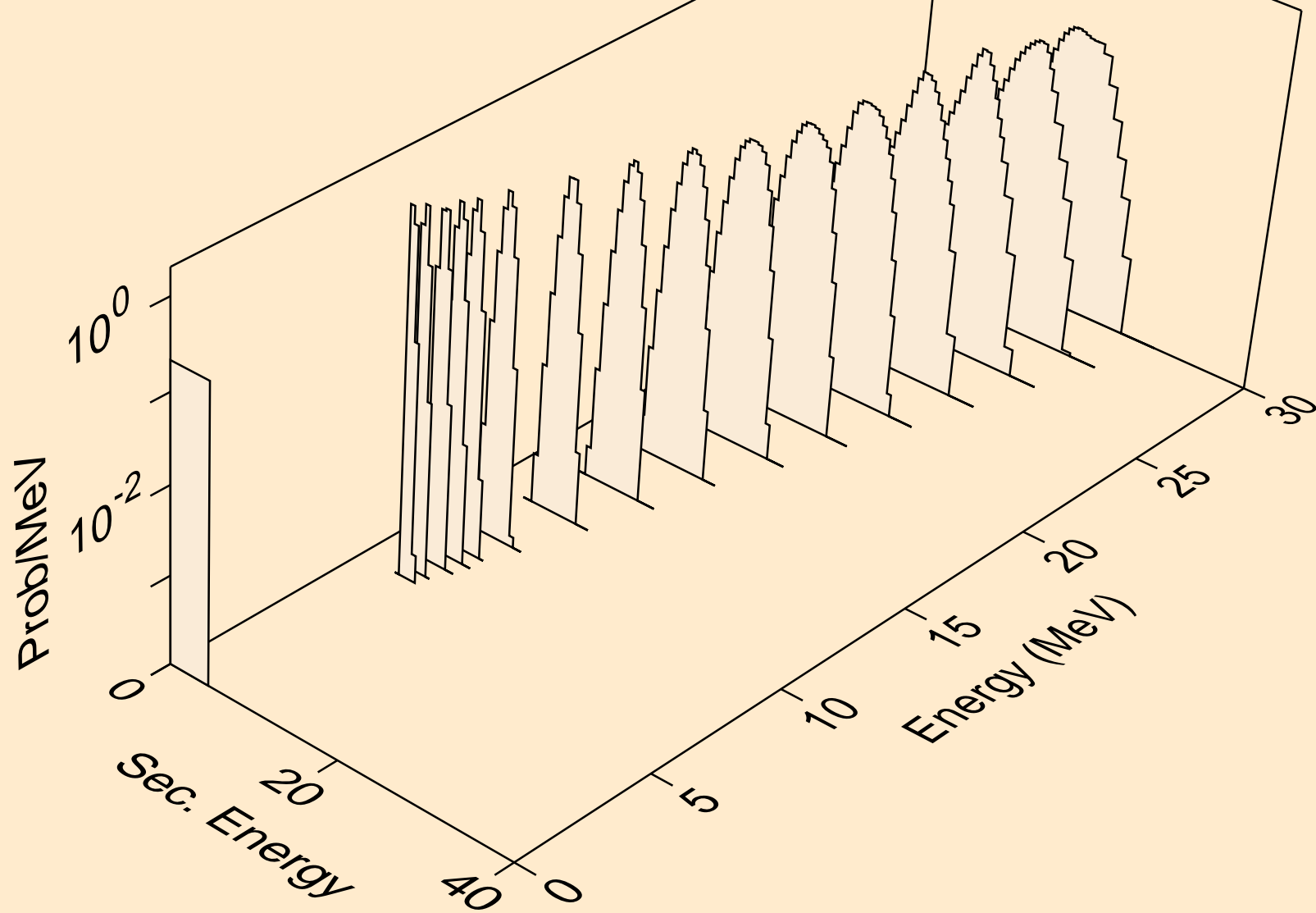

TM158 NEUTRON ACER TENDL-2024 LIBRARY; T=293.6K
alphas from (n,a)

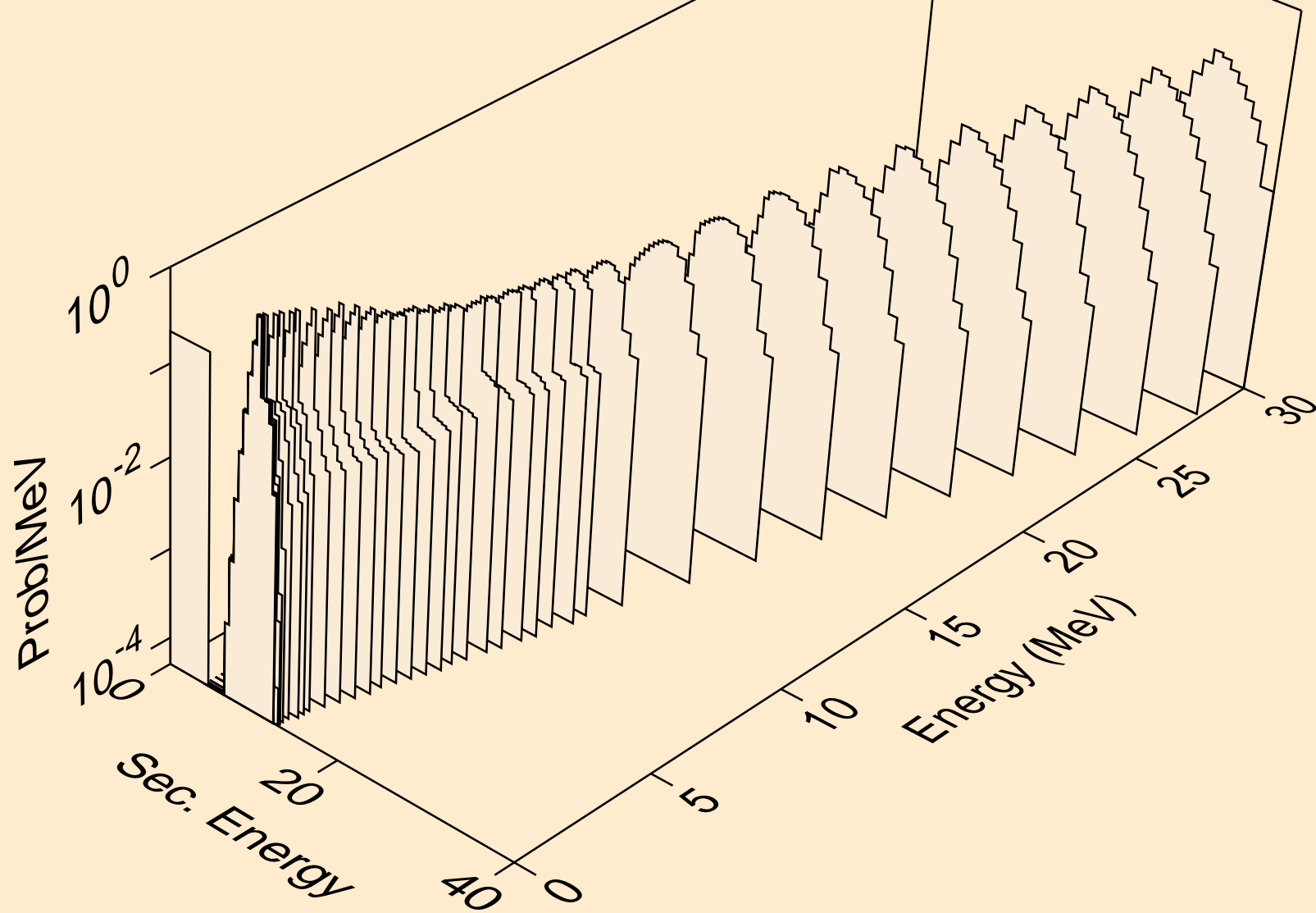

TM158 NEUTRON ACER TENDL-2024 LIBRARY; T=293.6K
alphas from (n,2a)

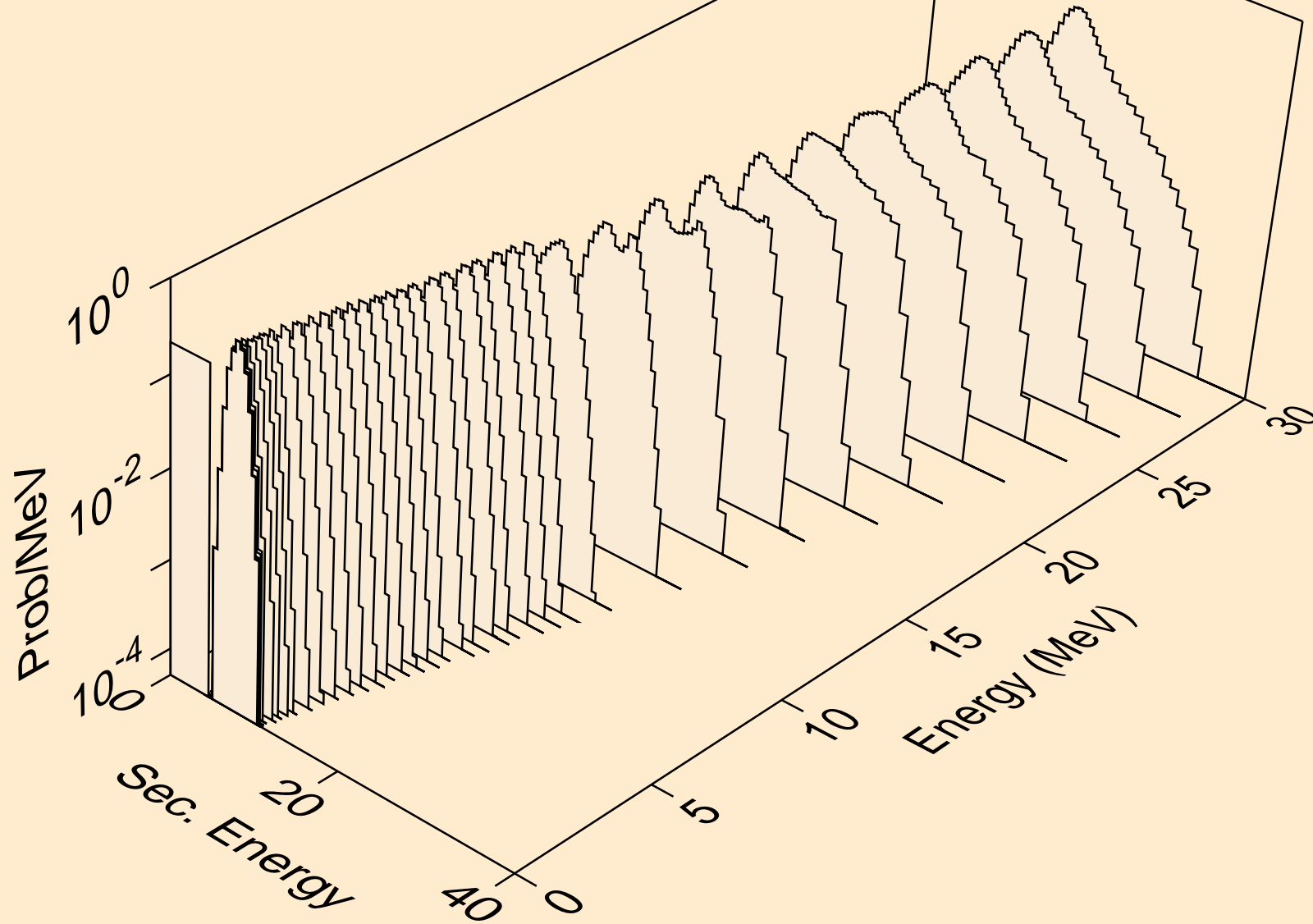

TM158 NEUTRON ACER TENDL-2024 LIBRARY; T=293.6K
alphas from (n,3a)

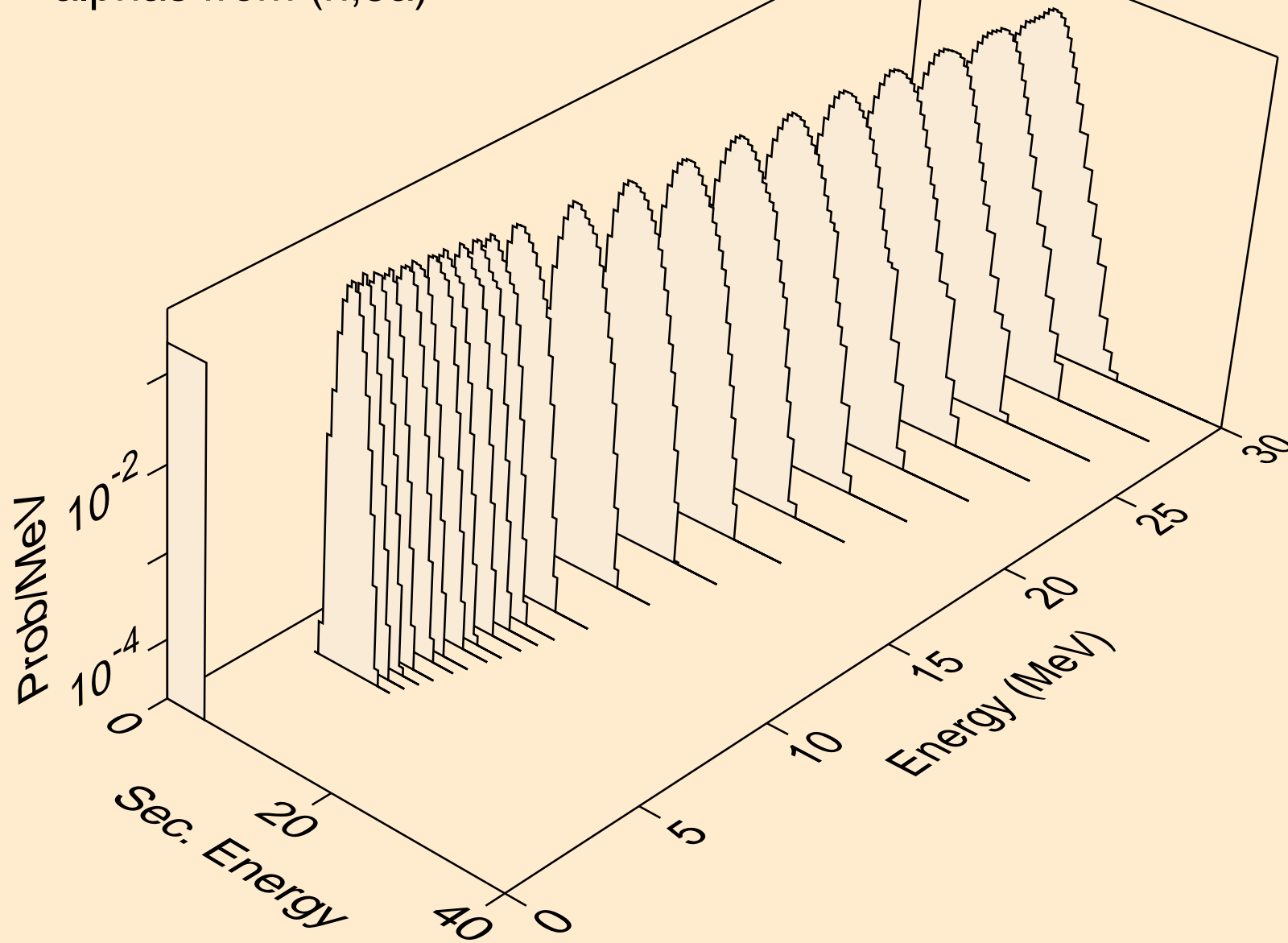

TM158 NEUTRON ACER TENDL-2024 LIBRARY; T=293.6K
alphas from (n,pa)

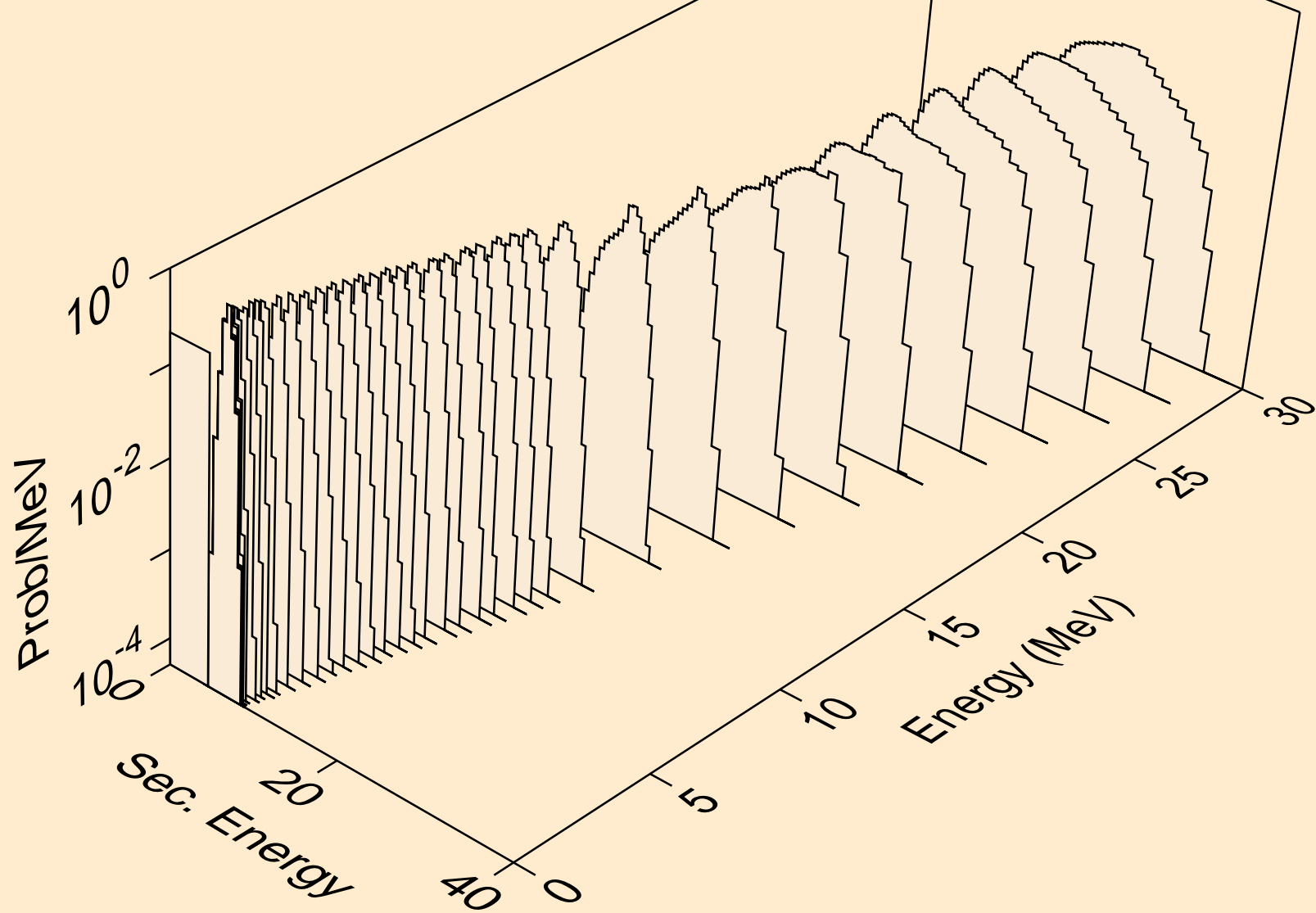

TM158 NEUTRON ACER TENDL-2024 LIBRARY; T=293.6K
alphas from (n,t2a)

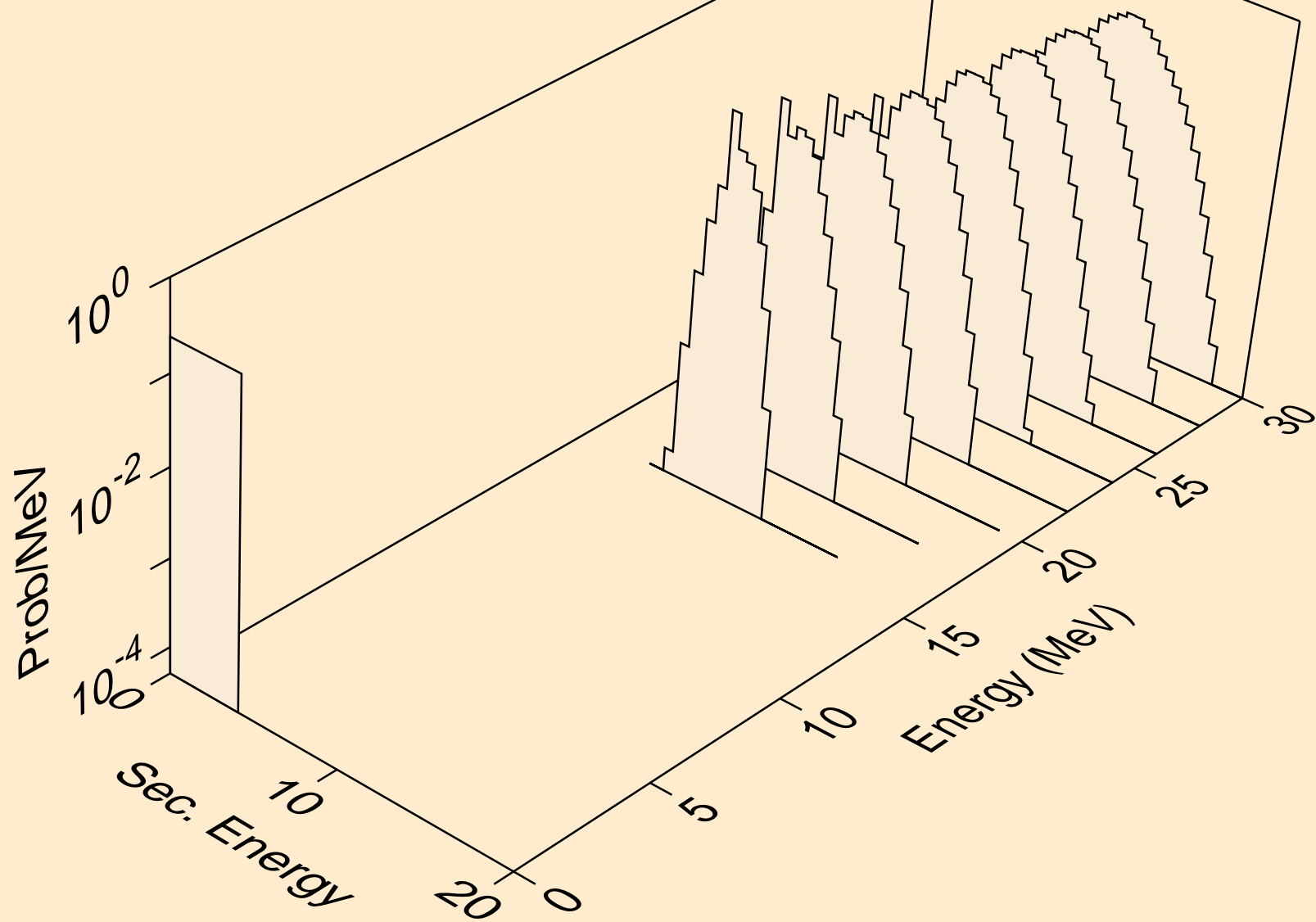

TM158 NEUTRON ACER TENDL-2024 LIBRARY; T=293.6K
alphas from (n,da)

