

F017 PROTON ACER TENDL-2024 LIBRARY; T=0.K

Principal cross sections

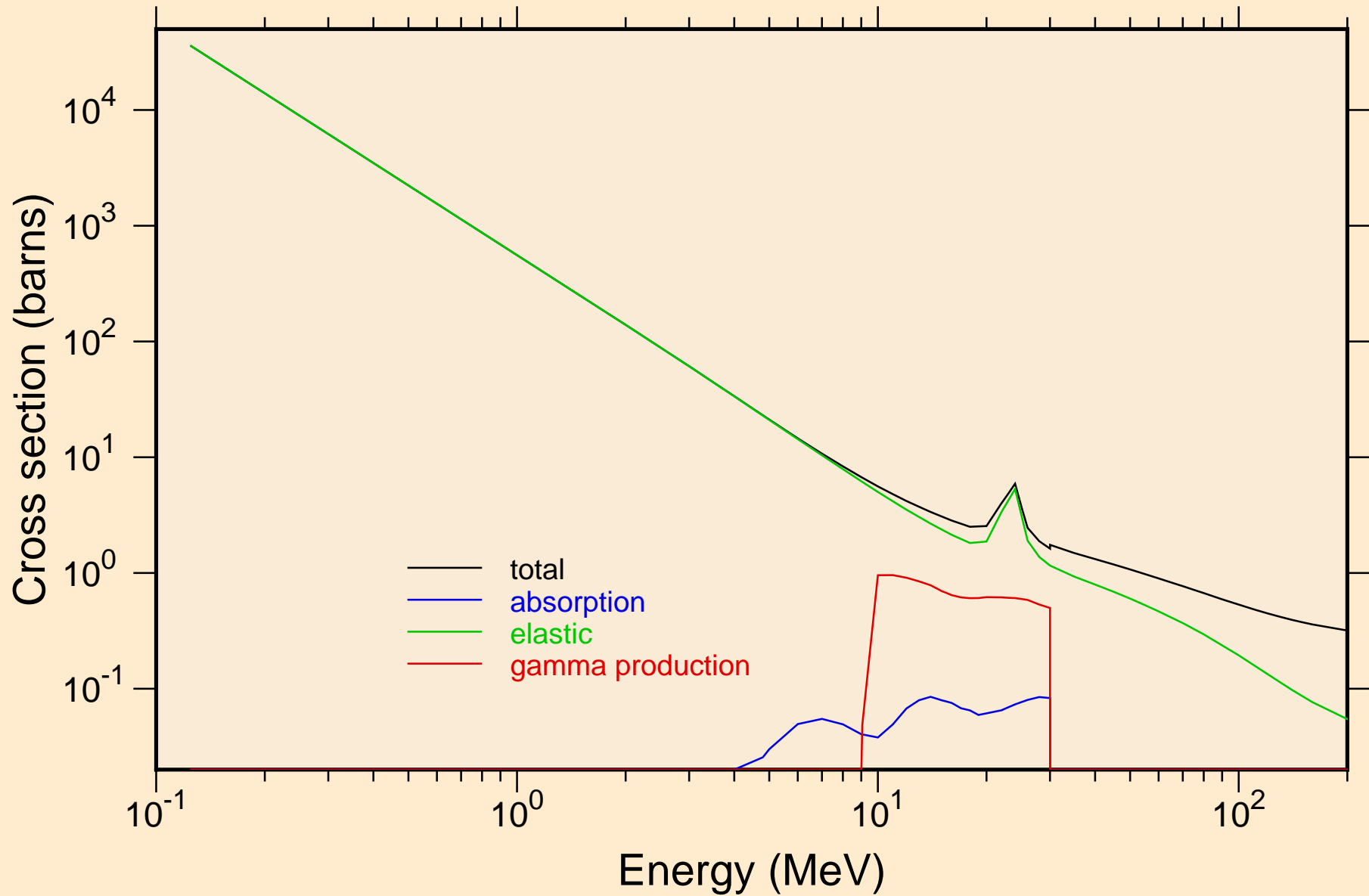

F017 PROTON ACER TENDL-2024 LIBRARY; T=0.K
Heating

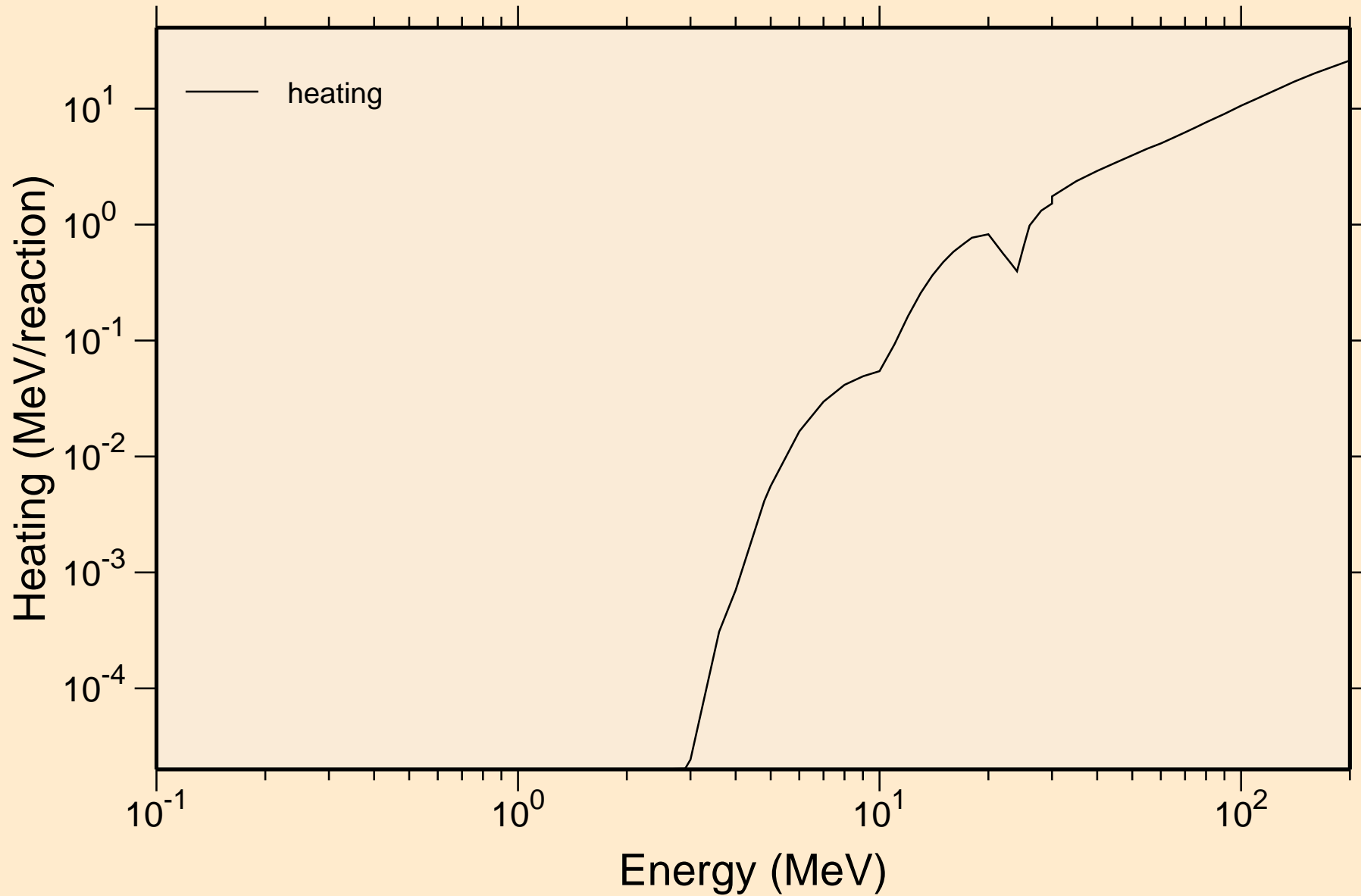

F017 PROTON ACER TENDL-2024 LIBRARY; T=0.K

Principal cross sections

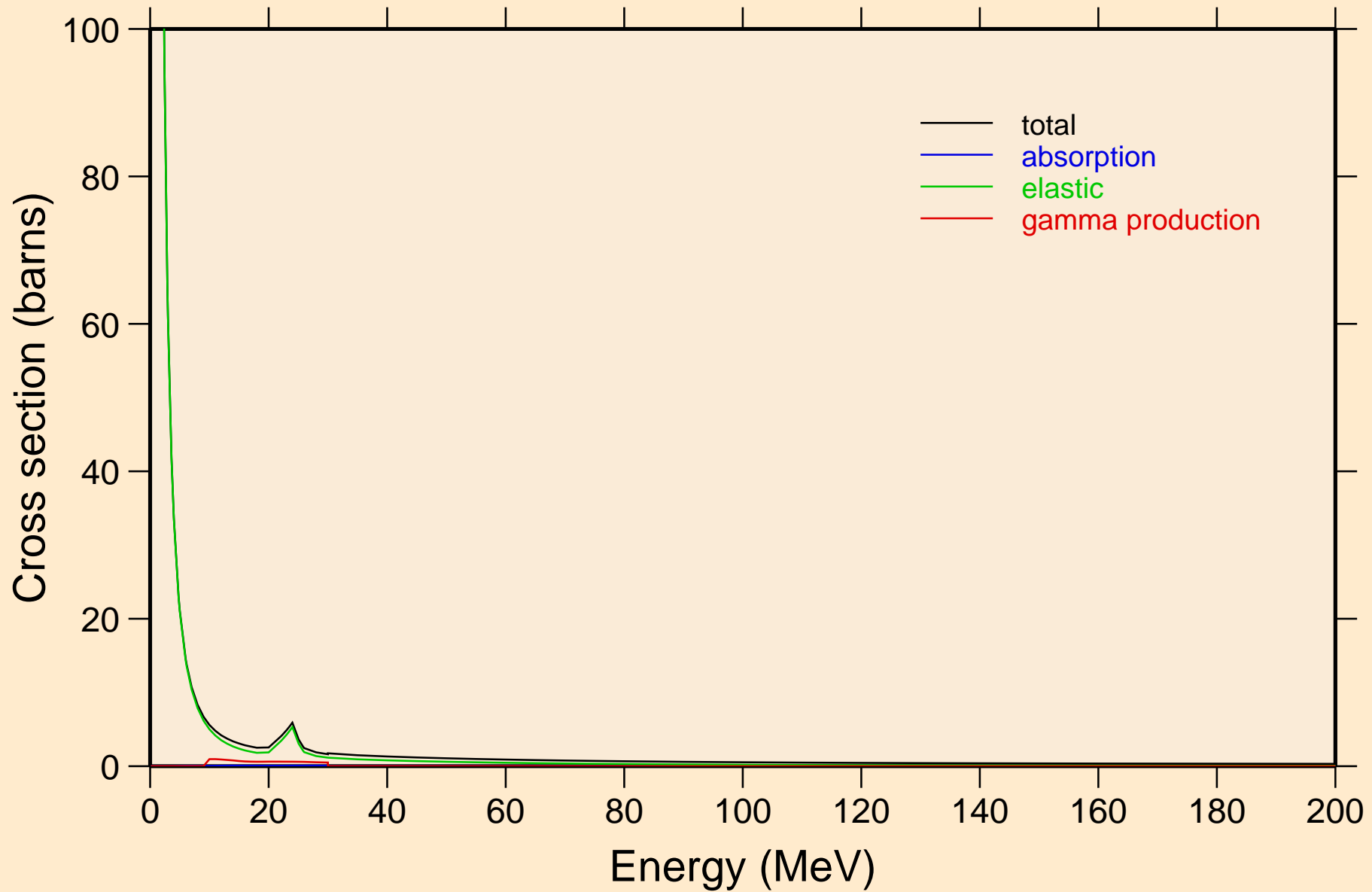

F017 PROTON ACER TENDL-2024 LIBRARY; T=0.K

Heating

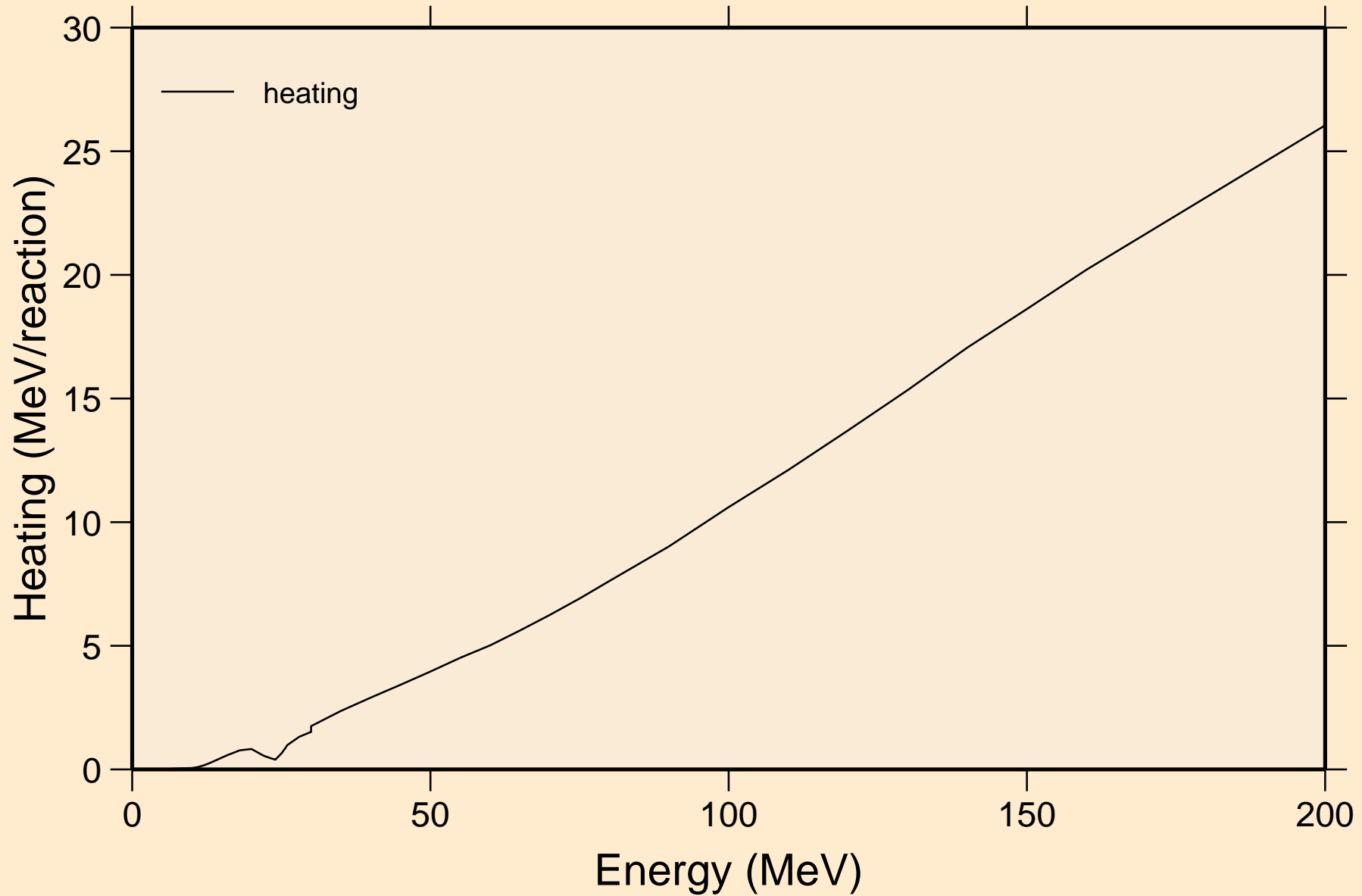

F017 PROTON ACER TENDL-2024 LIBRARY; T=0.K

Threshold reactions

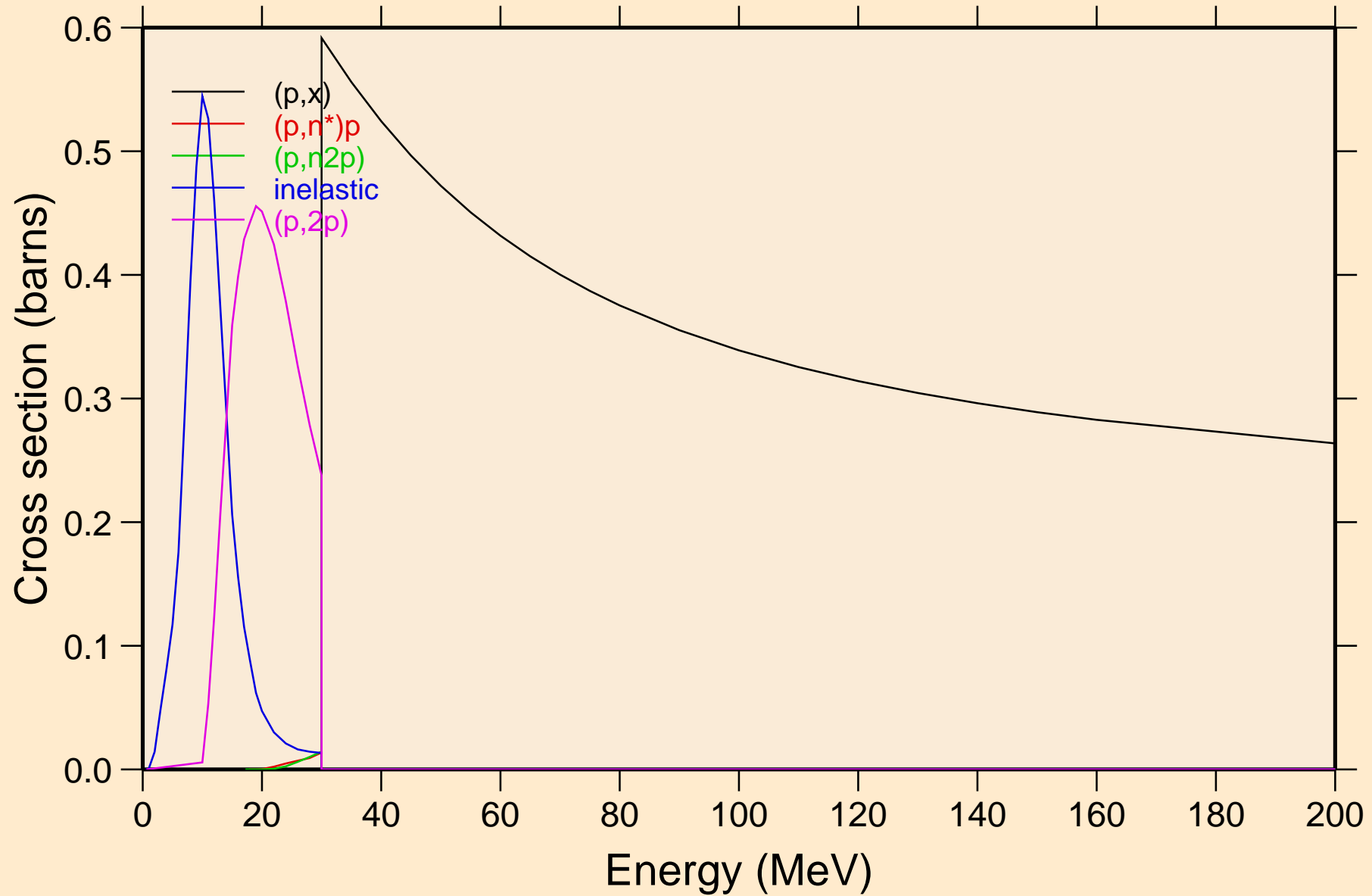

F017 PROTON ACER TENDL-2024 LIBRARY; T=0.K

Threshold reactions

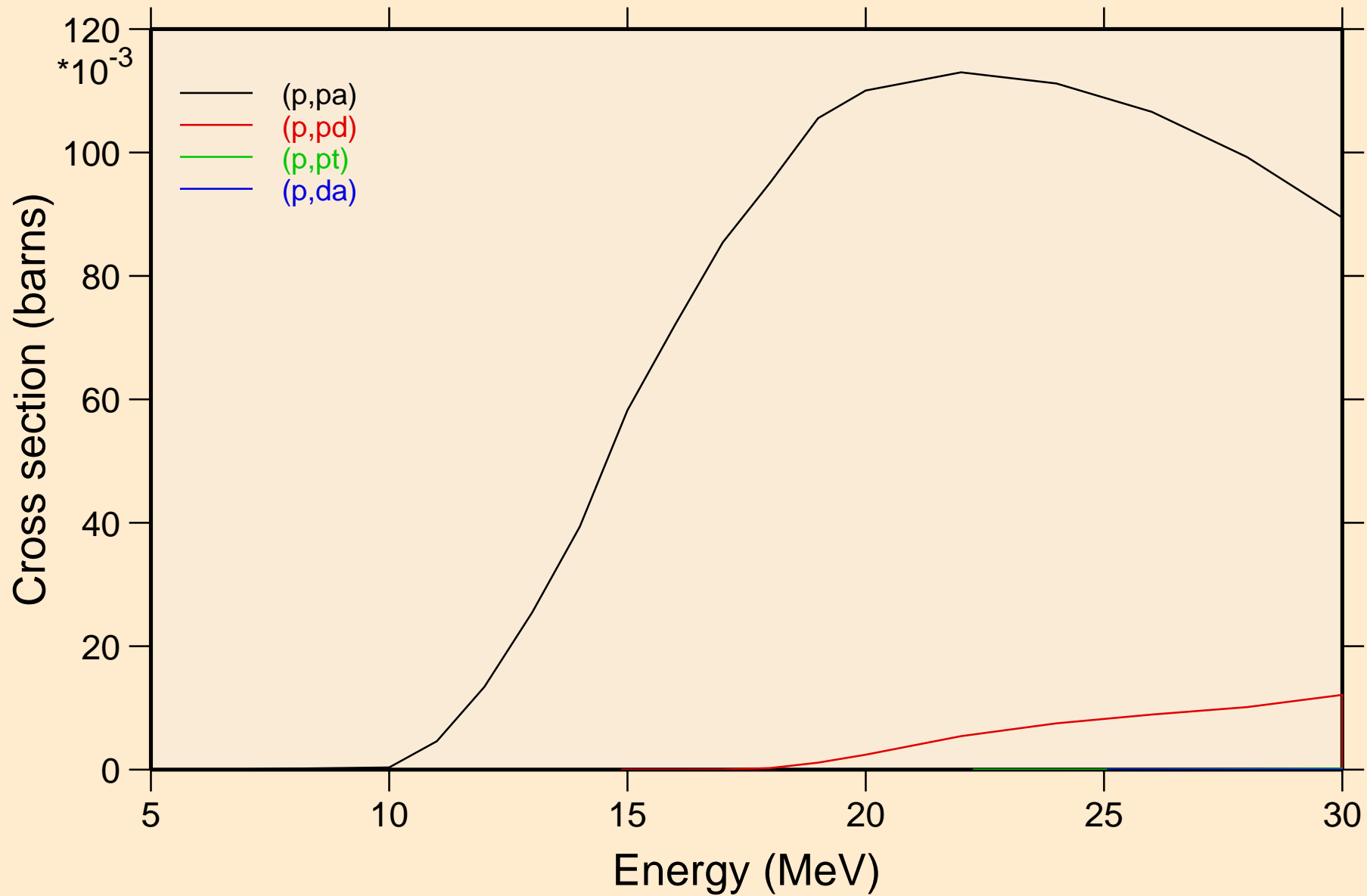

F017 PROTON ACER TENDL-2024 LIBRARY; T=0.K
angular distribution for elastic

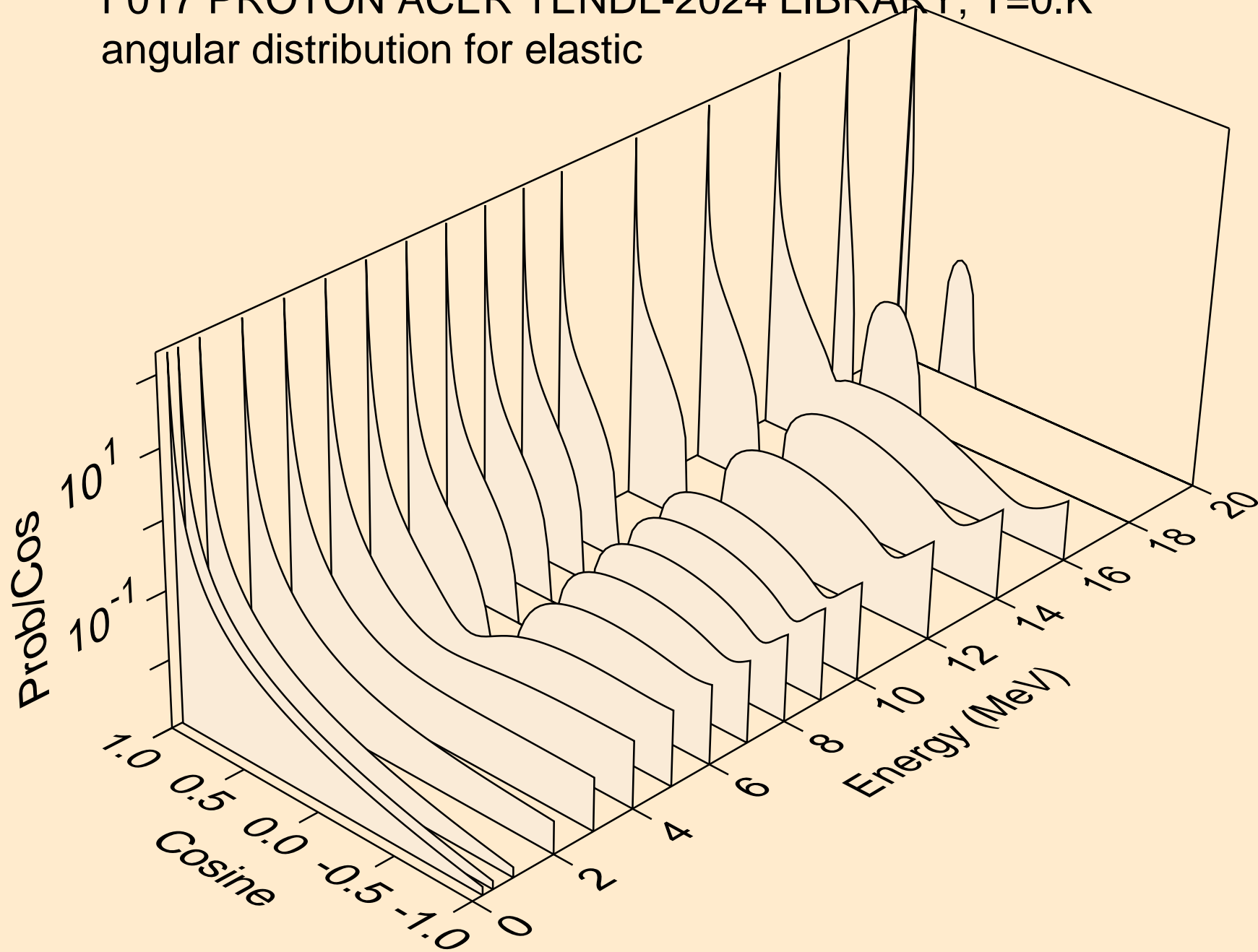

F017 PROTON ACER TENDL-2024 LIBRARY; T=0.K
angular distribution for elastic

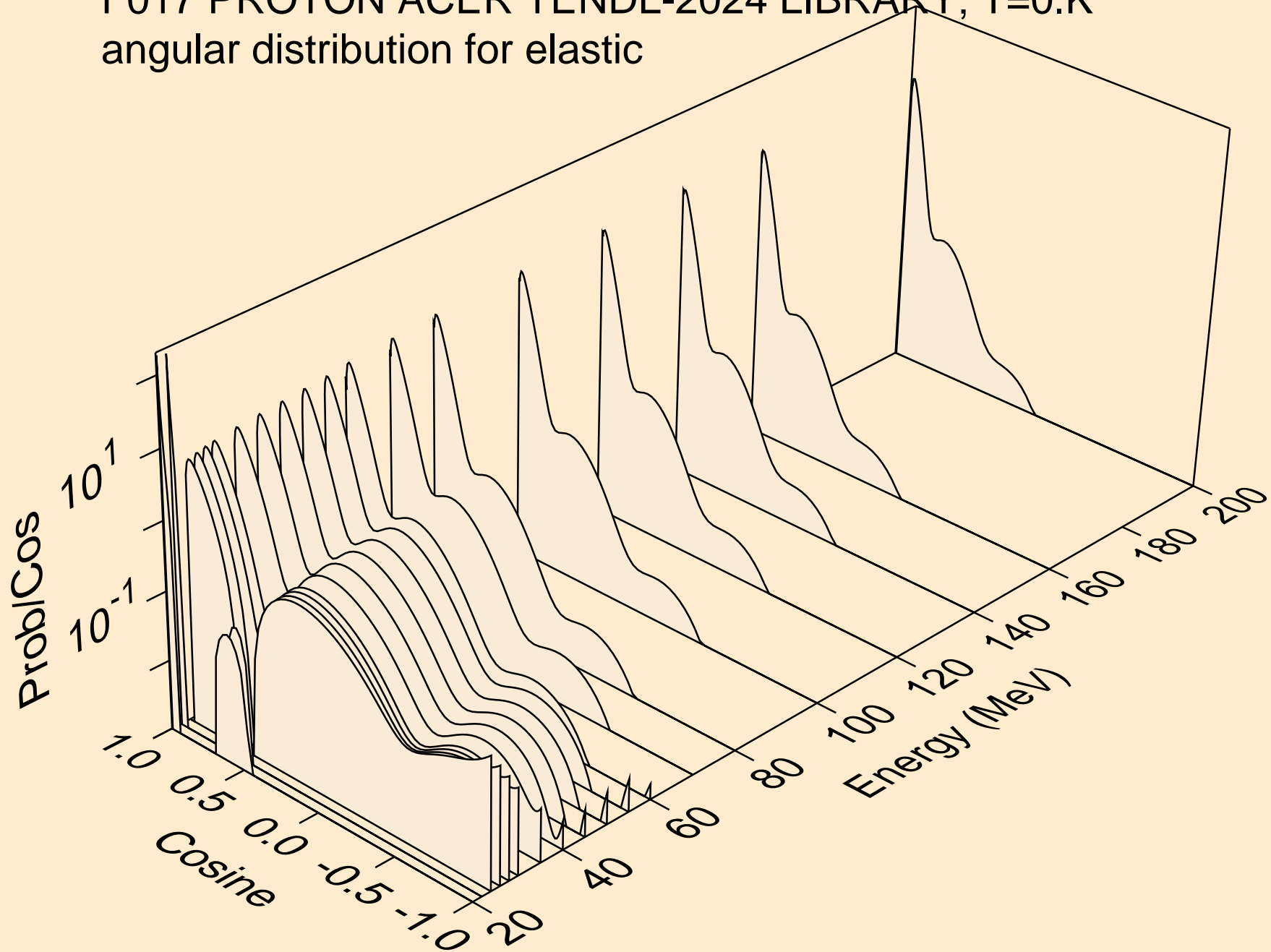

F017 PROTON ACER TENDL-2024 LIBRARY; T=0.K
Proton emission for (p,x)

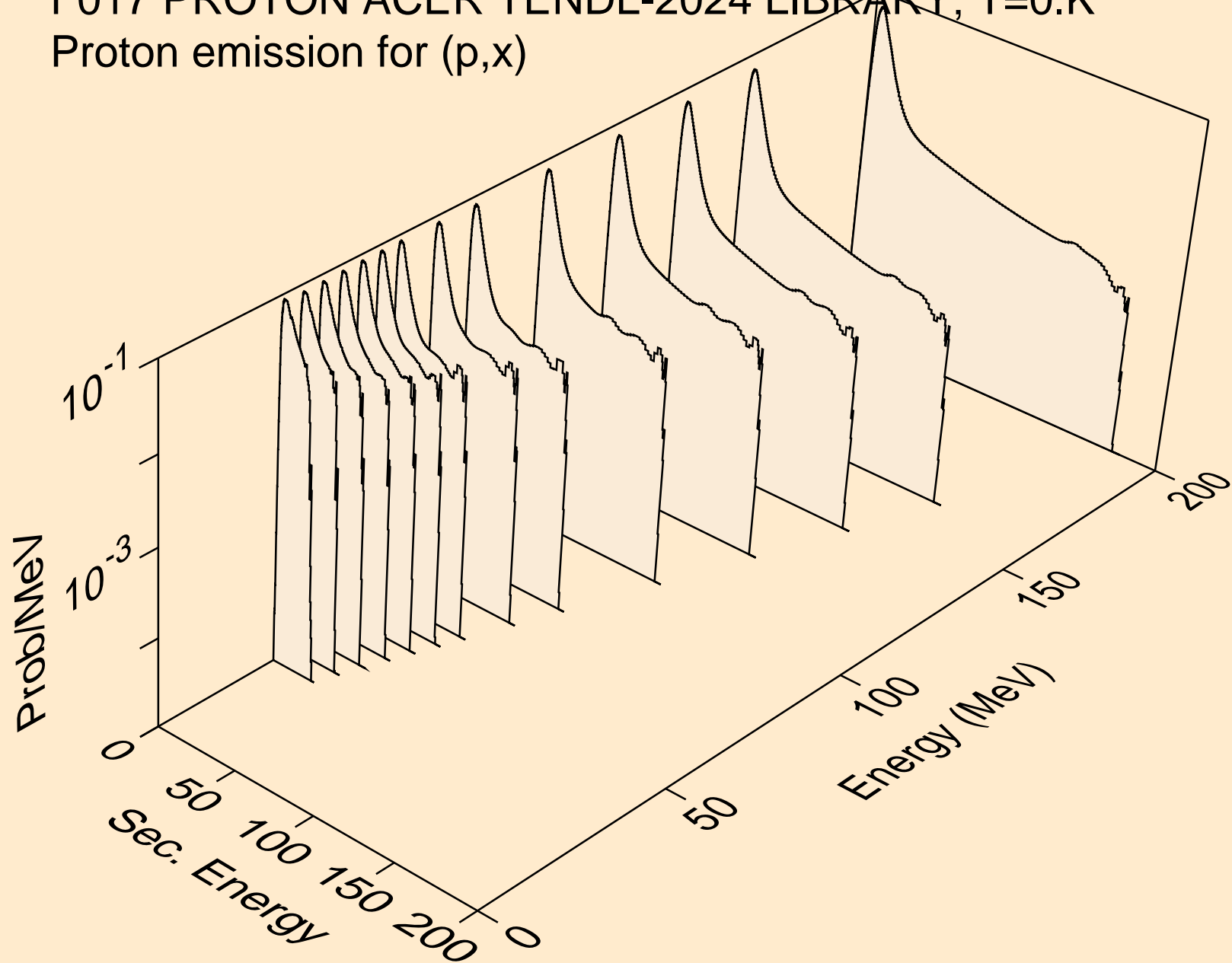

F017 PROTON ACER TENDL-2024 LIBRARY; T=0.K
Proton emission for (p,n*)p

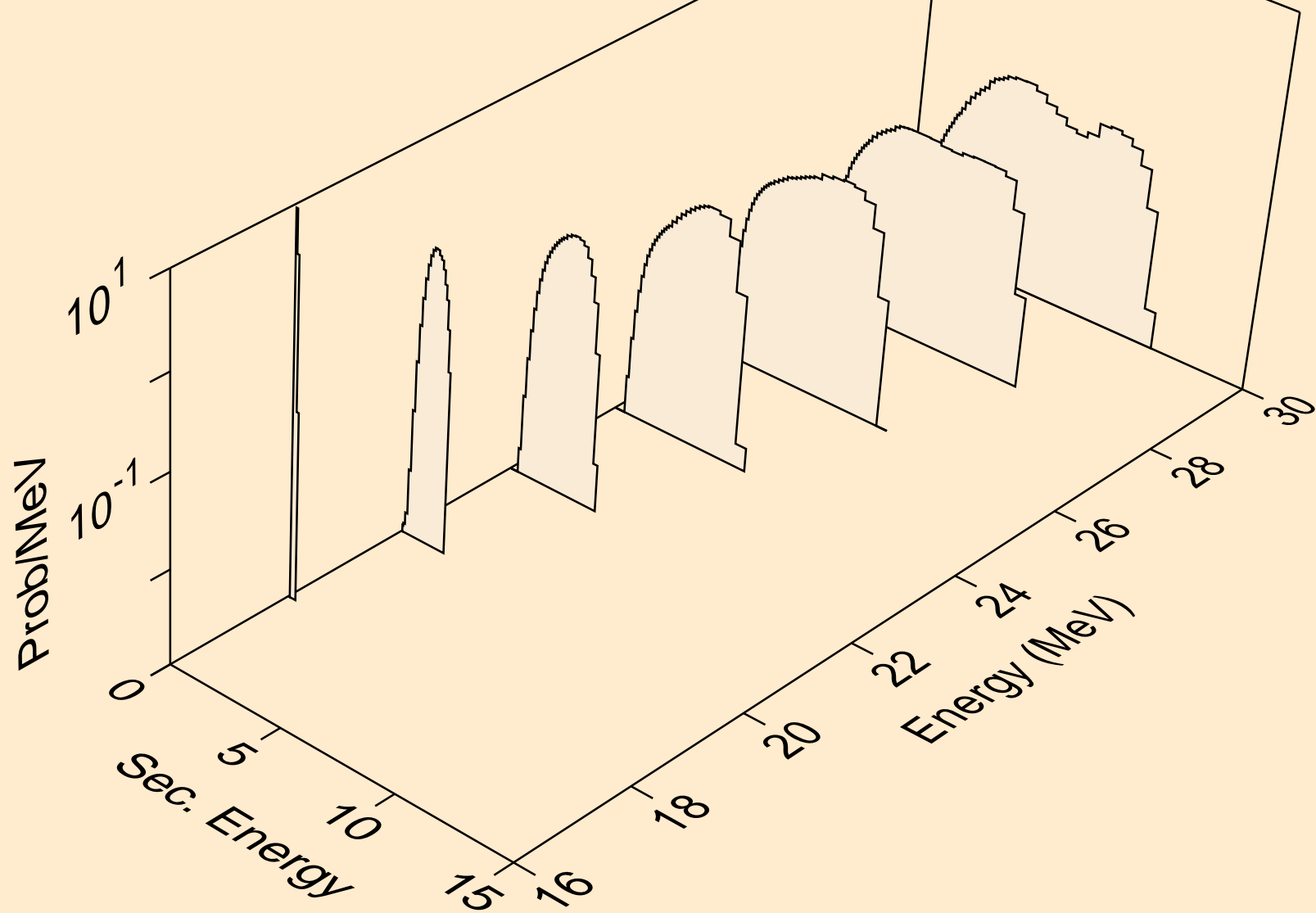

F017 PROTON ACER TENDL-2024 LIBRARY; T=0.K
Proton emission for (p,n2p)

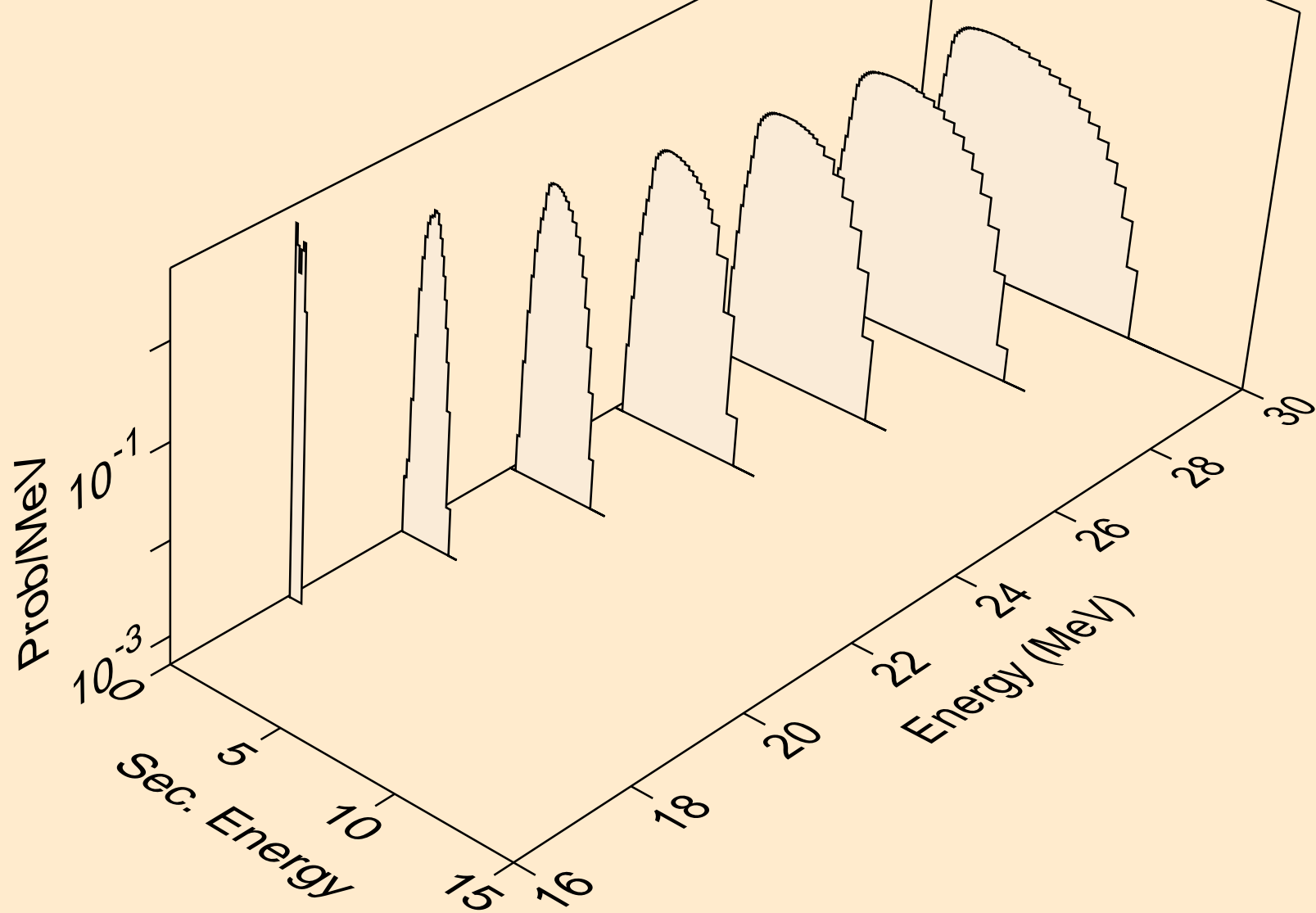

F017 PROTON ACER TENDL-2024 LIBRARY; T=0.K
Proton emission for inelastic

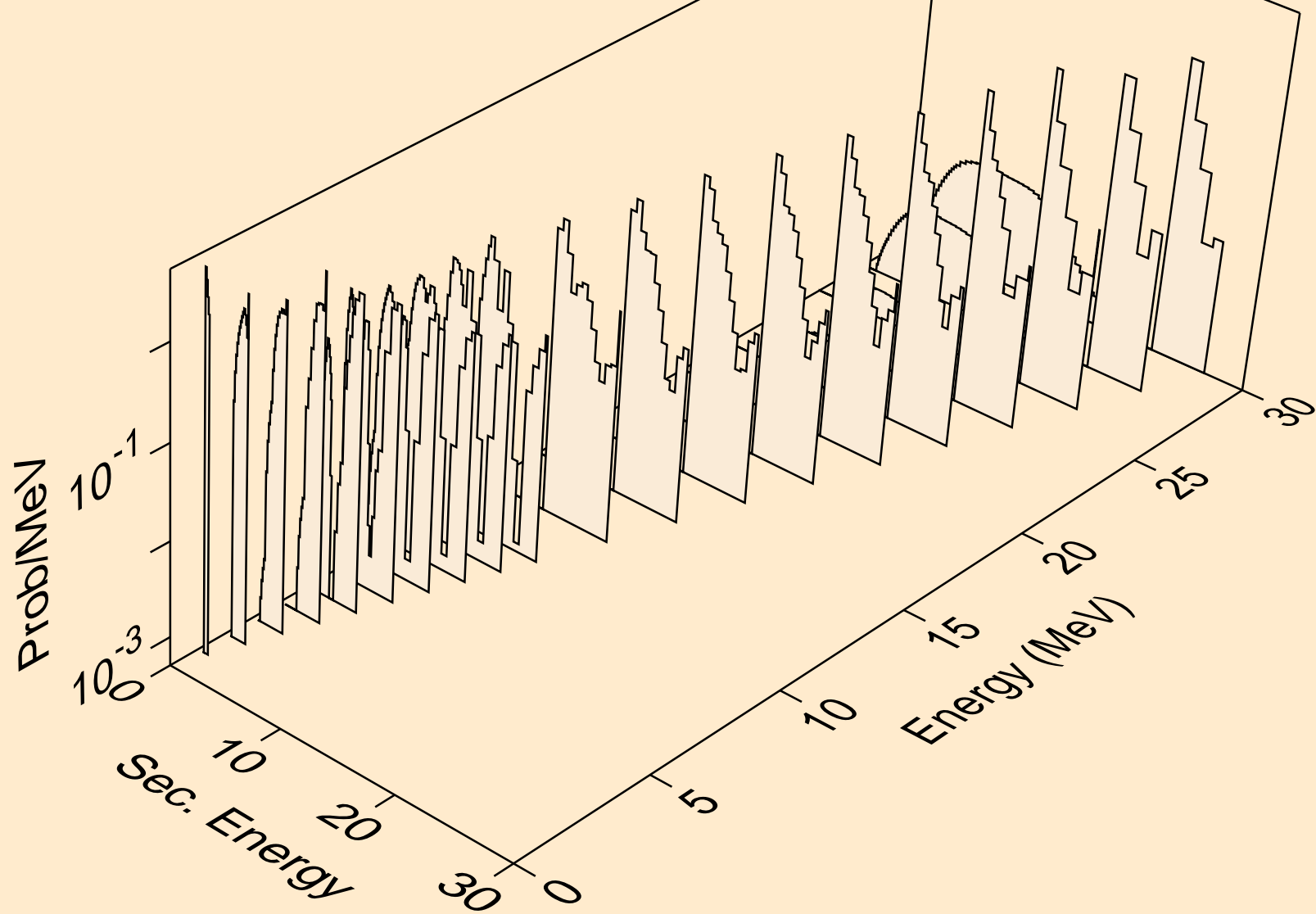

F017 PROTON ACER TENDL-2024 LIBRARY; T=0.K
Proton emission for (p,2p)

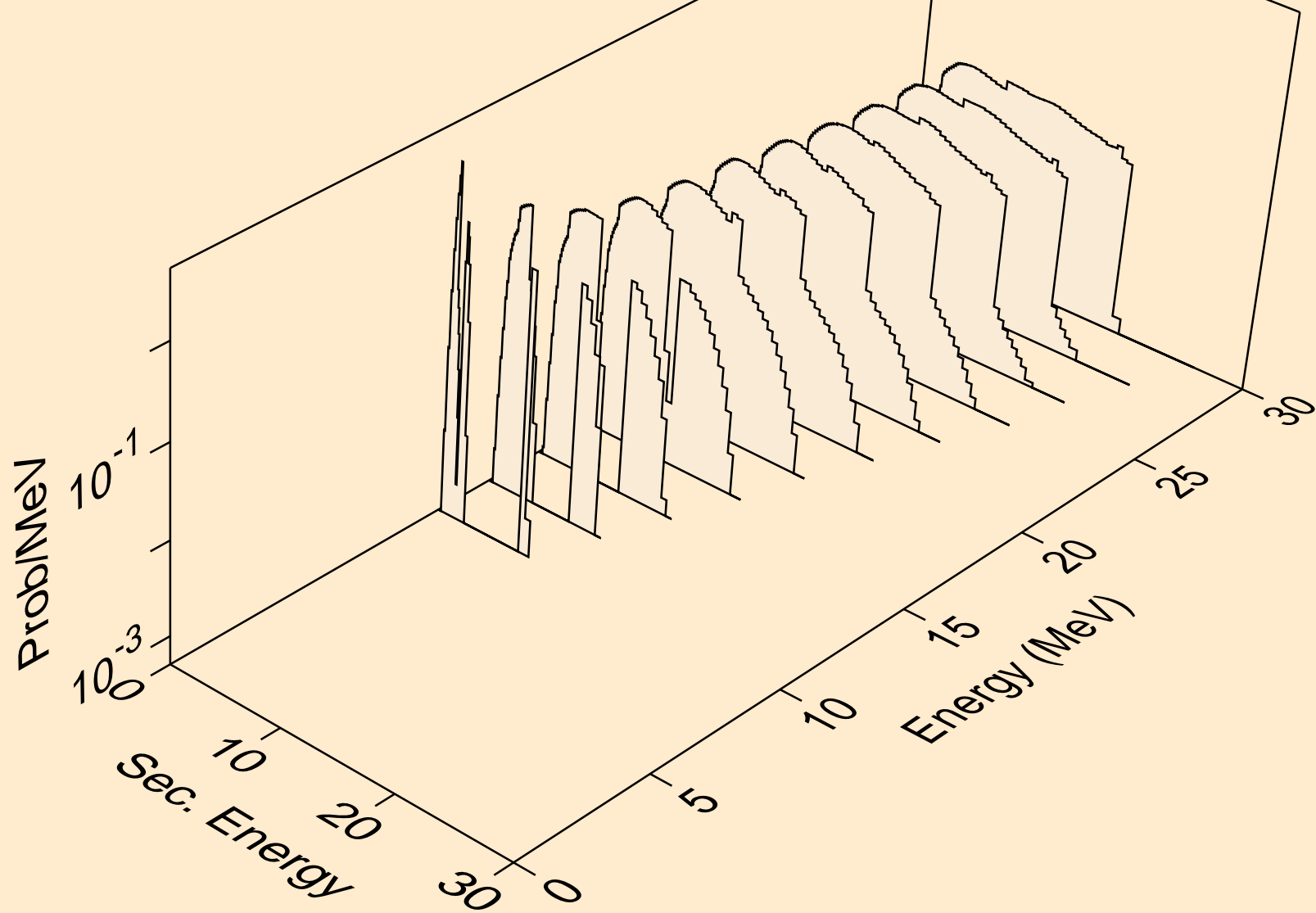

F017 PROTON ACER TENDL-2024 LIBRARY; T=0.K
Proton emission for (p,pa)

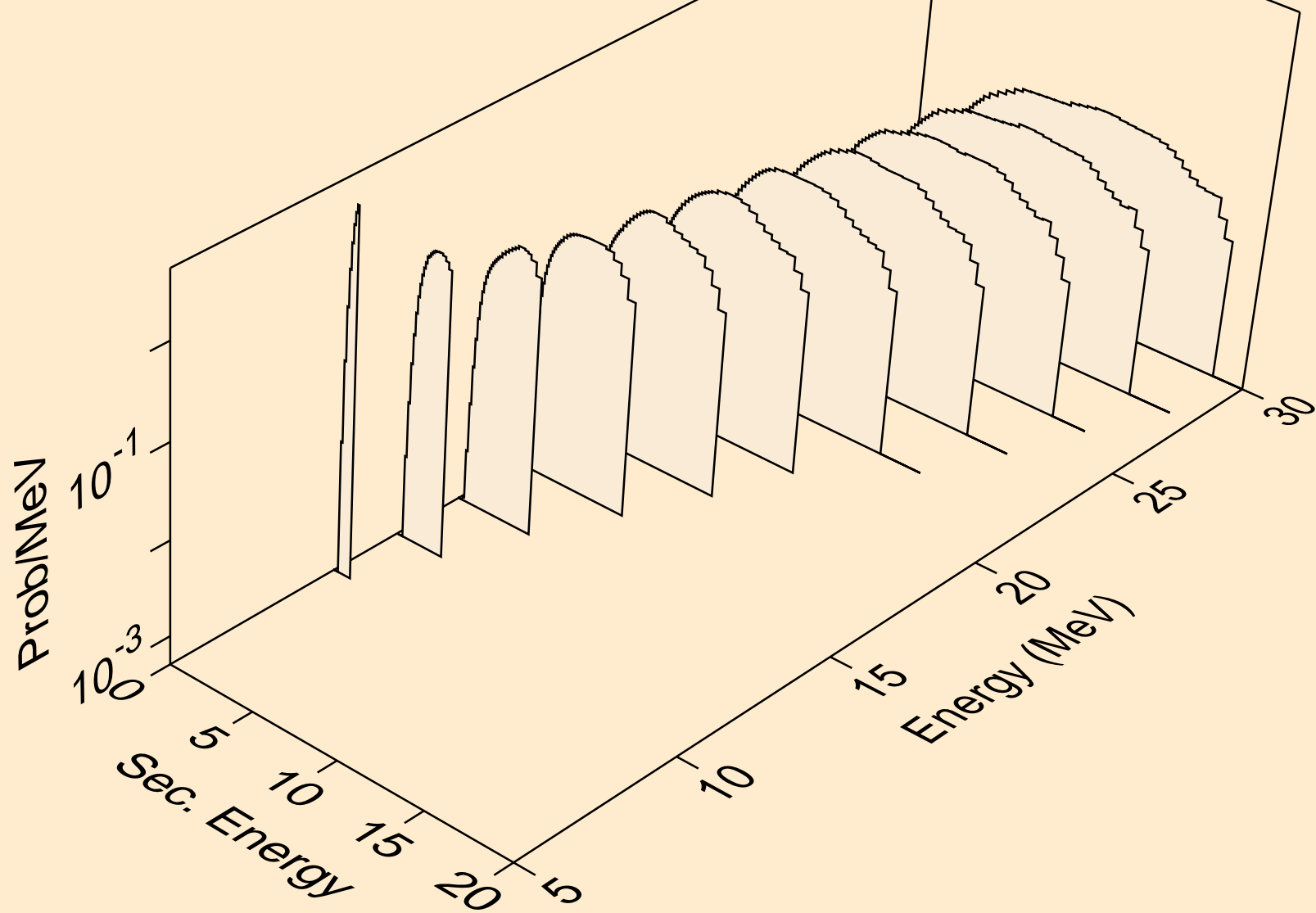

F017 PROTON ACER TENDL-2024 LIBRARY; T=0.K
Proton emission for (p,pd)

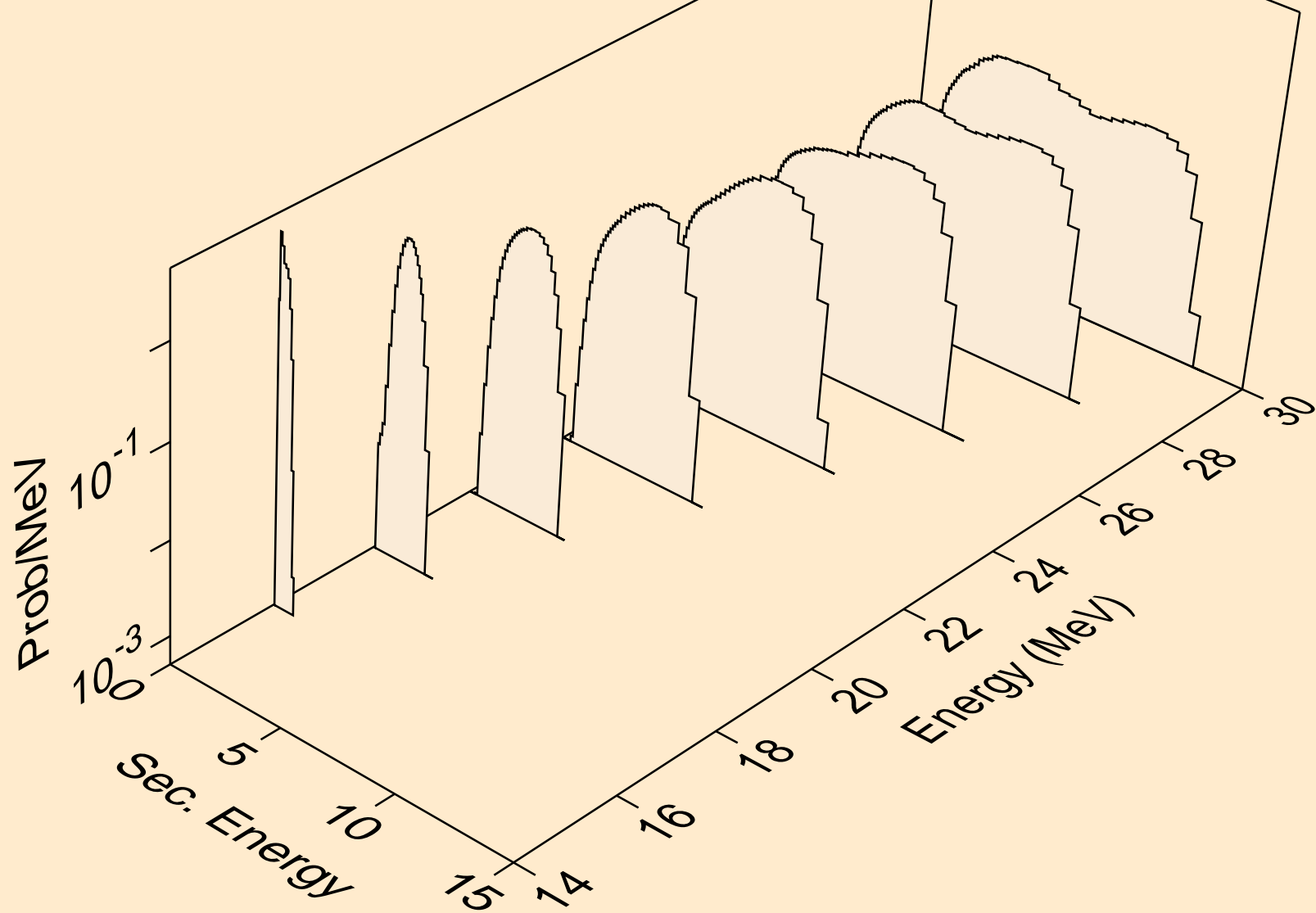

F017 PROTON ACER TENDL-2024 LIBRARY; T=0.K
Proton emission for (p,pt)

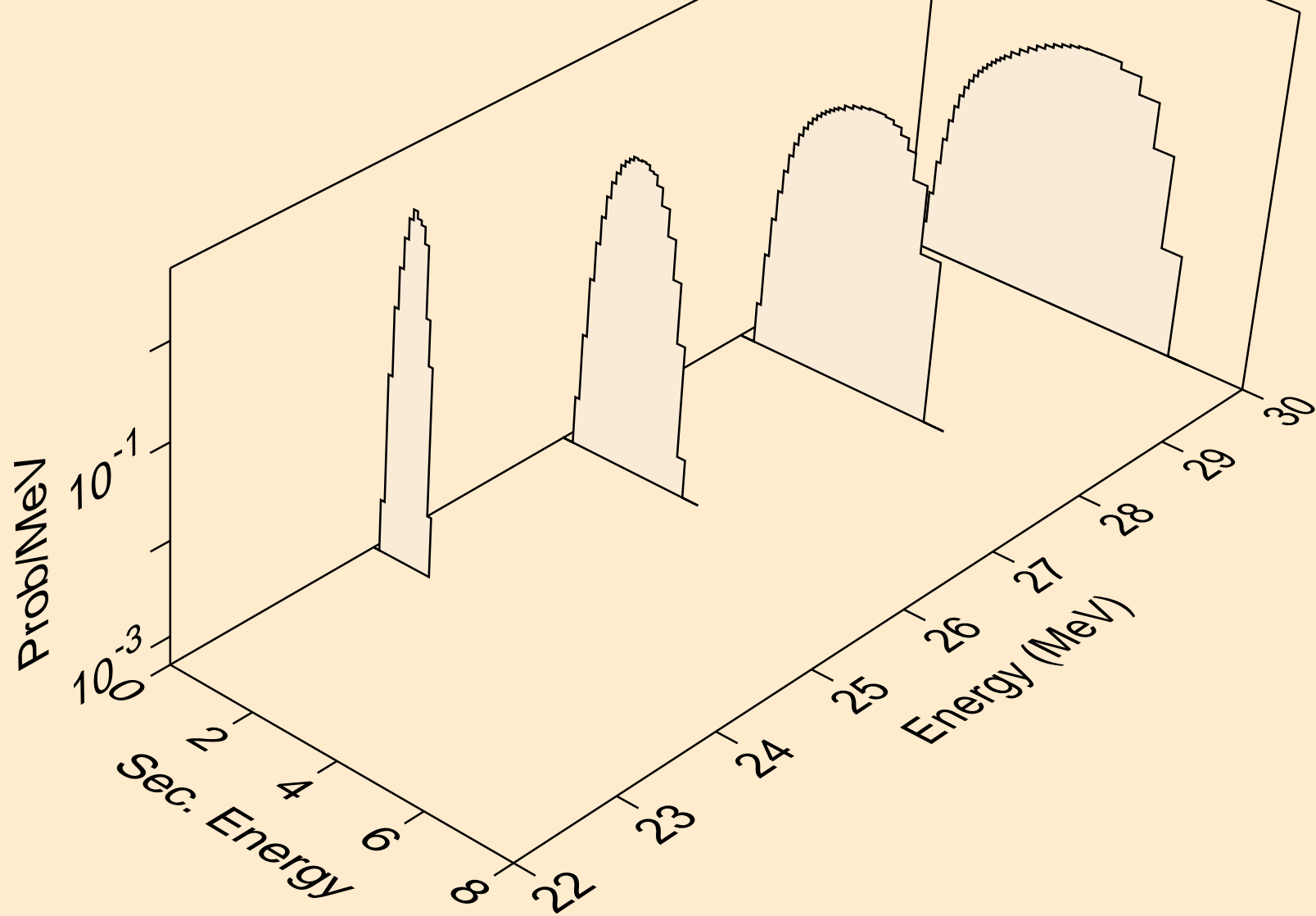

F017 PROTON ACER TENDL-2024 LIBRARY; T=0.K
Photon emission for (z,n)

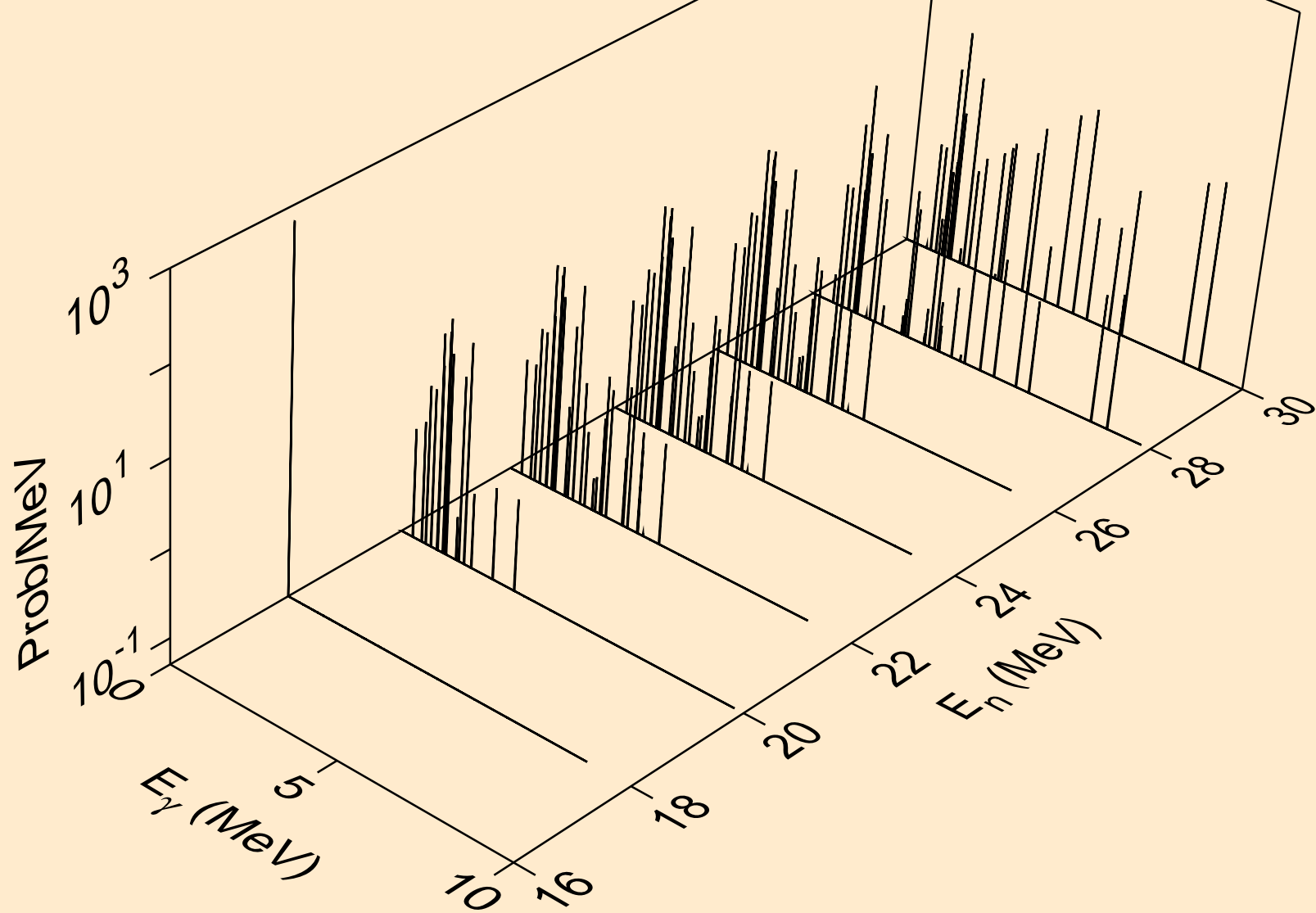

F017 PROTON ACER TENDL-2024 LIBRARY; T=0.K
Photon emission for (z,x)

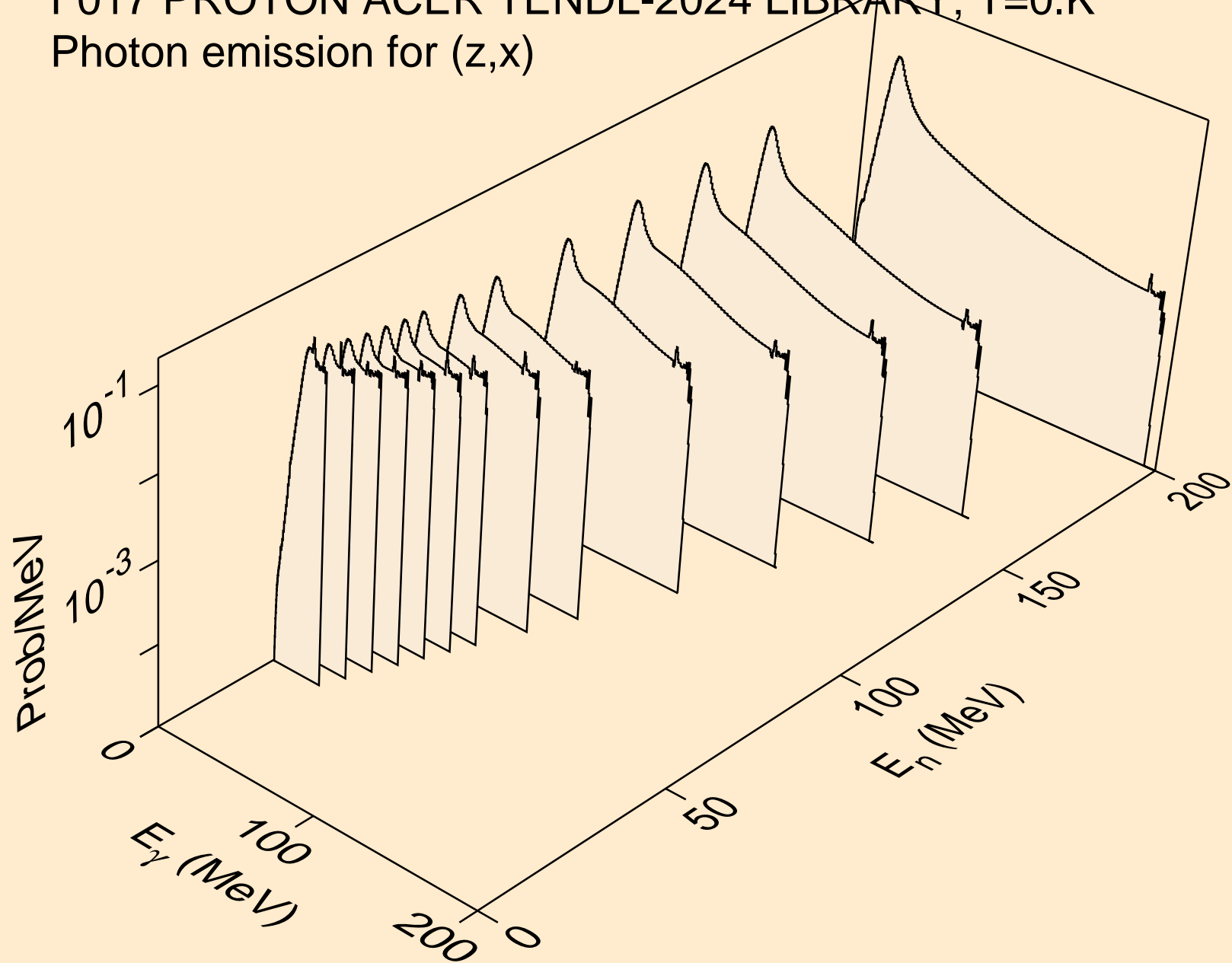

F017 PROTON ACER TENDL-2024 LIBRARY; T=0.K
Photon emission for (n,n*)a

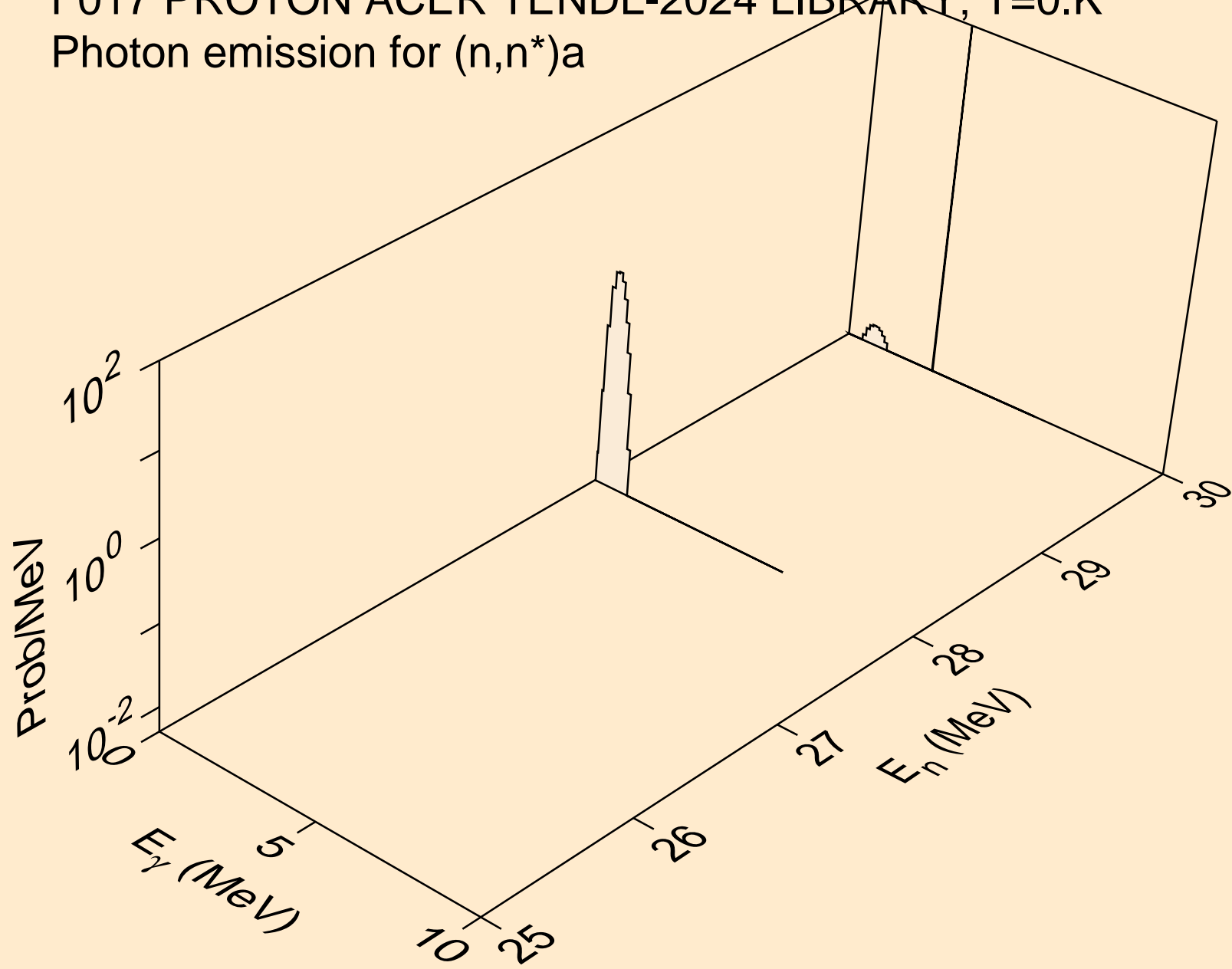

F017 PROTON ACER TENDL-2024 LIBRARY; T=0.K
Photon emission for (n,n*)p

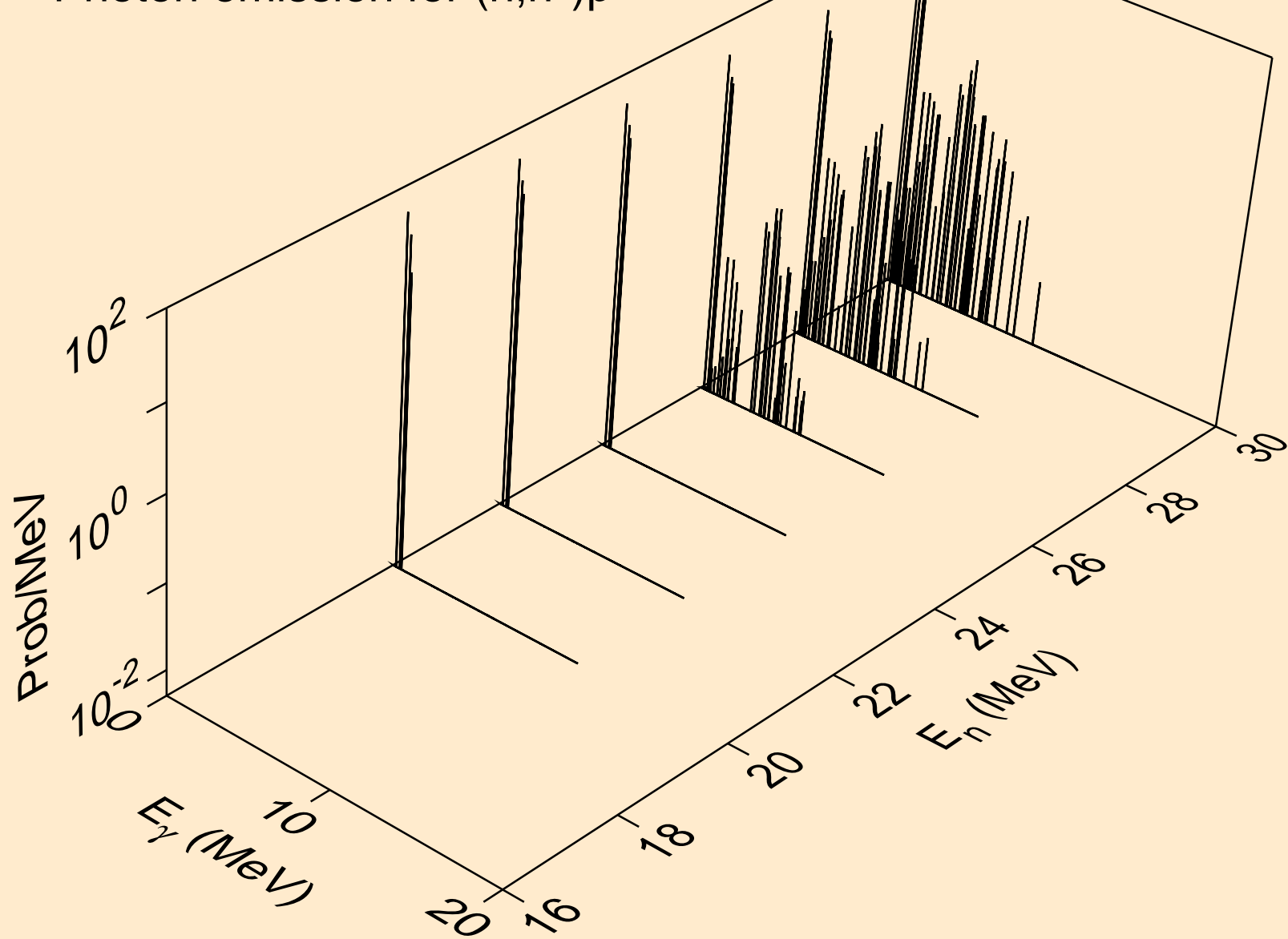

F017 PROTON ACER TENDL-2024 LIBRARY; T=0.K
Photon emission for (n,n*)he3

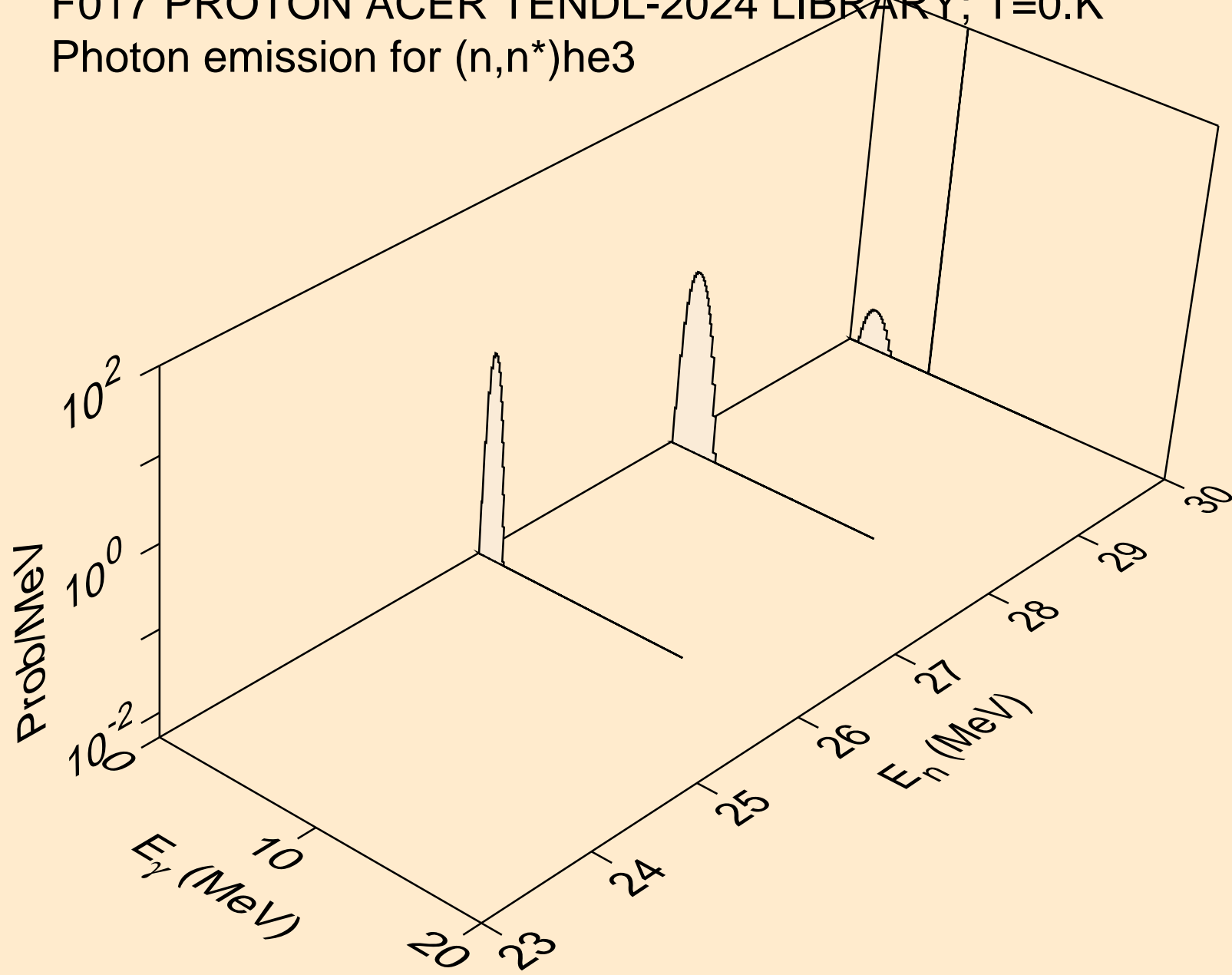

F017 PROTON ACER TENDL-2024 LIBRARY; T=0.K
Photon emission for (n,n2p)

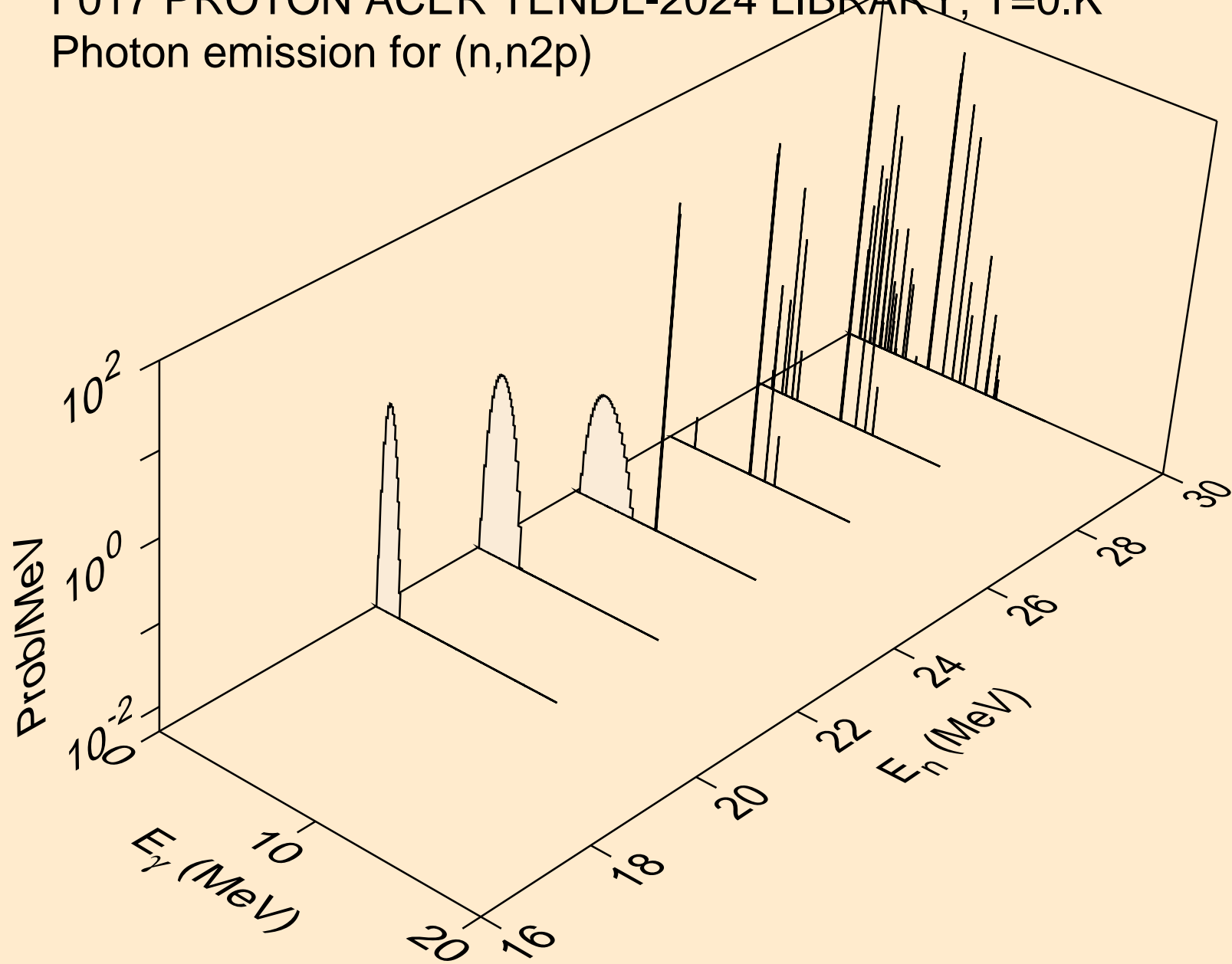

F017 PROTON ACER TENDL-2024 LIBRARY; T=0.K
Photon emission for (n,gma)

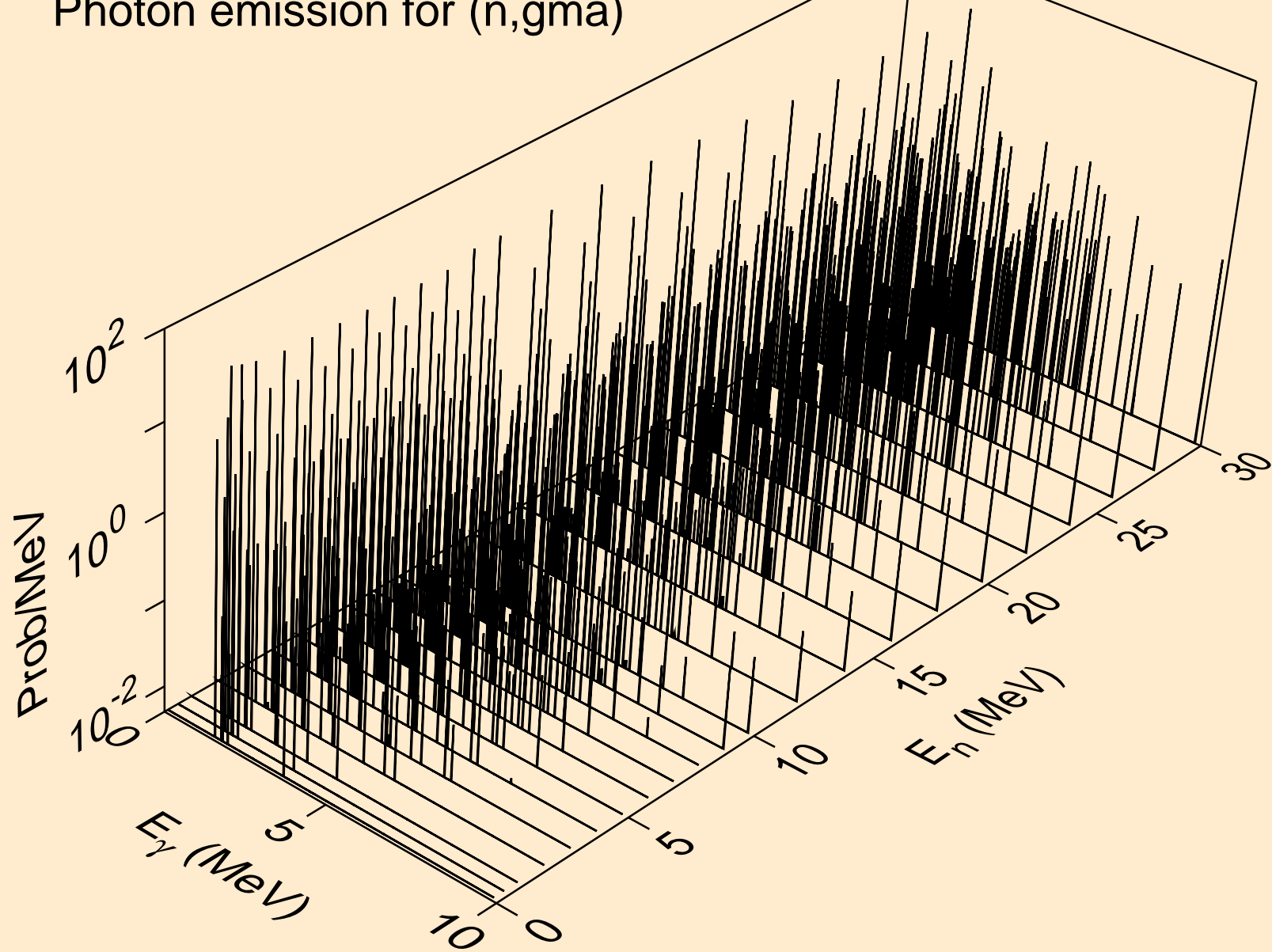

F017 PROTON ACER TENDL-2024 LIBRARY; T=0.K
Photon emission for inelastic

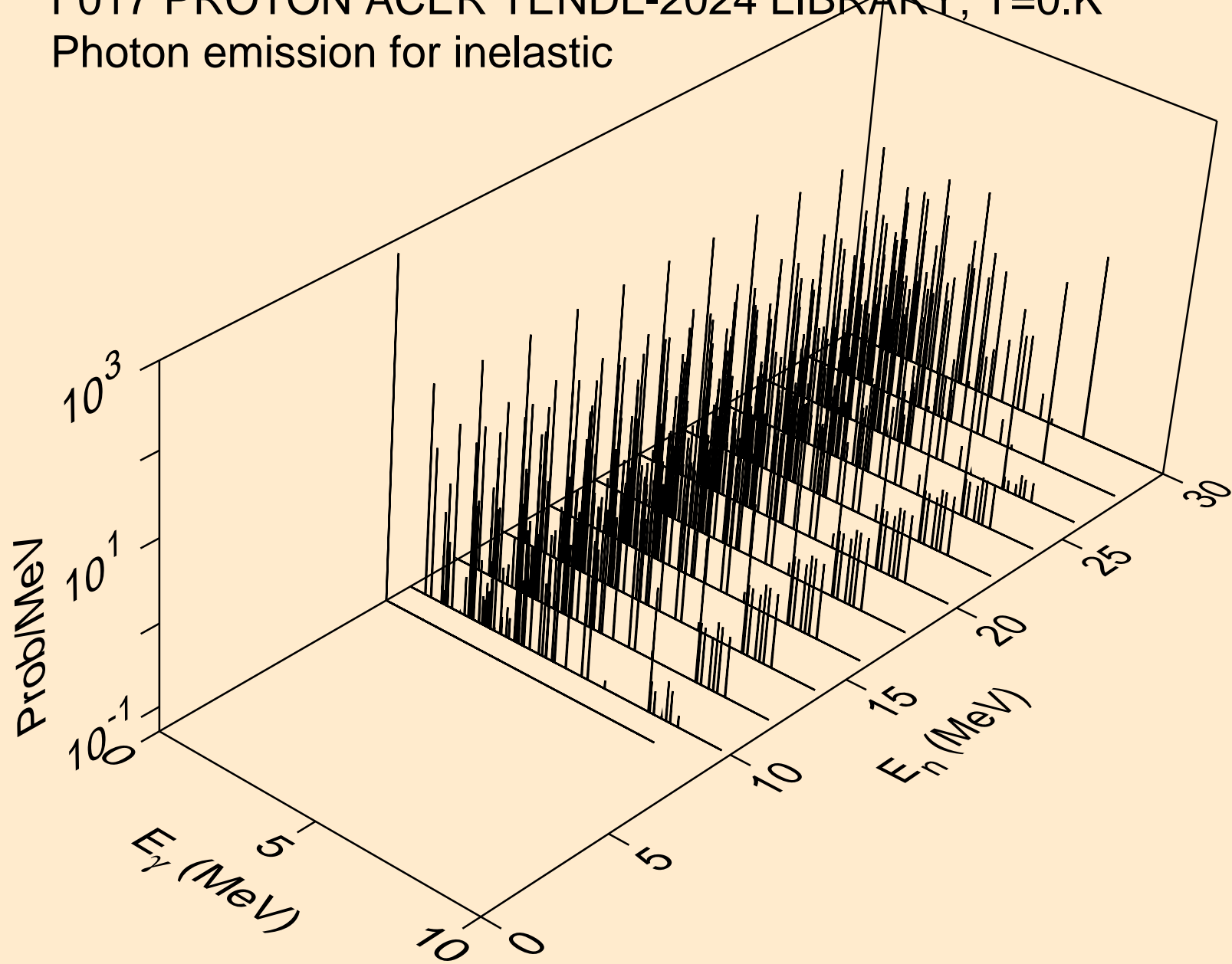

F017 PROTON ACER TENDL-2024 LIBRARY; T=0.K
Photon emission for (n,d)

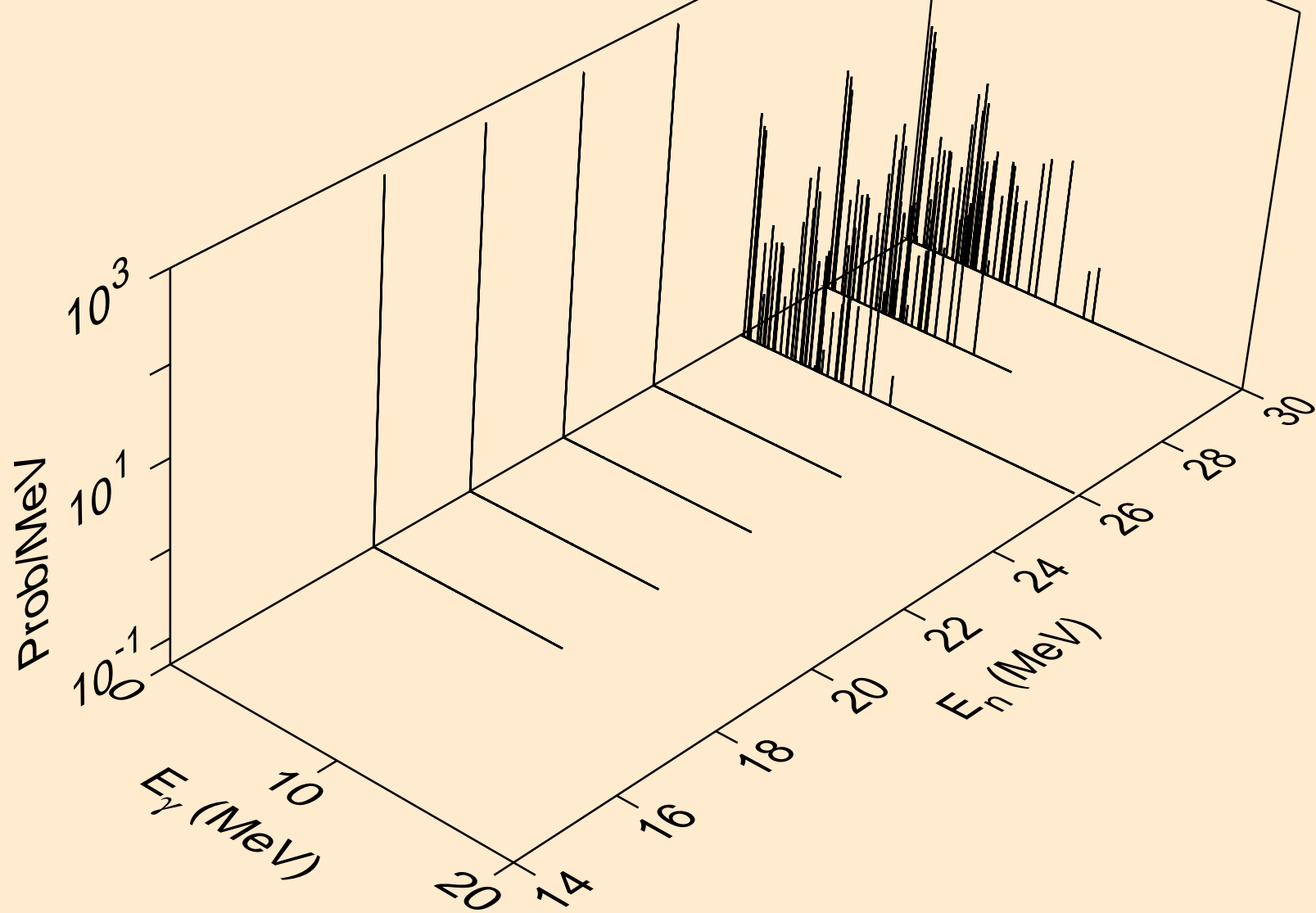

F017 PROTON ACER TENDL-2024 LIBRARY; T=0.K
Photon emission for (n,t)

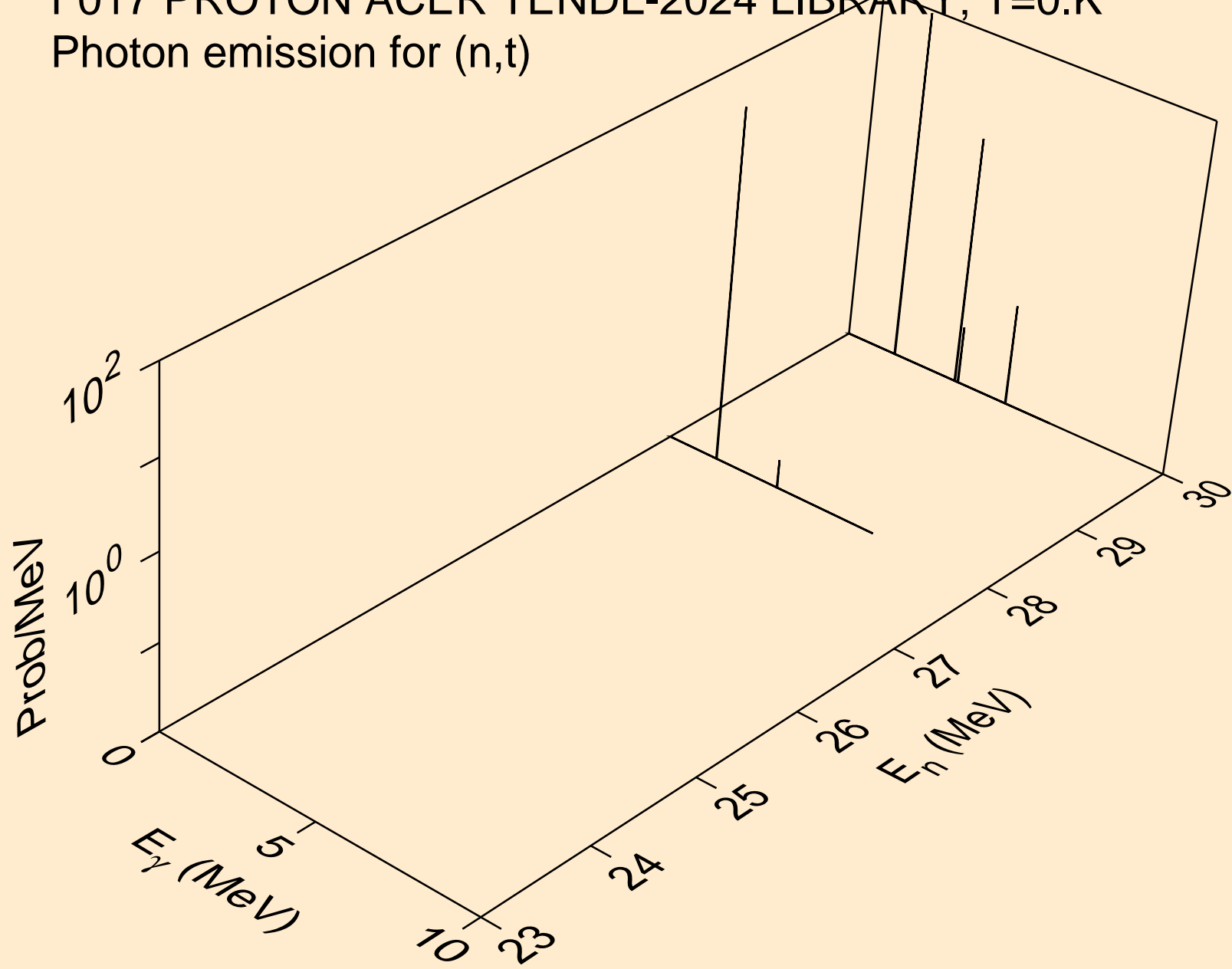

F017 PROTON ACER TENDL-2024 LIBRARY; T=0.K
Photon emission for (n,he3)

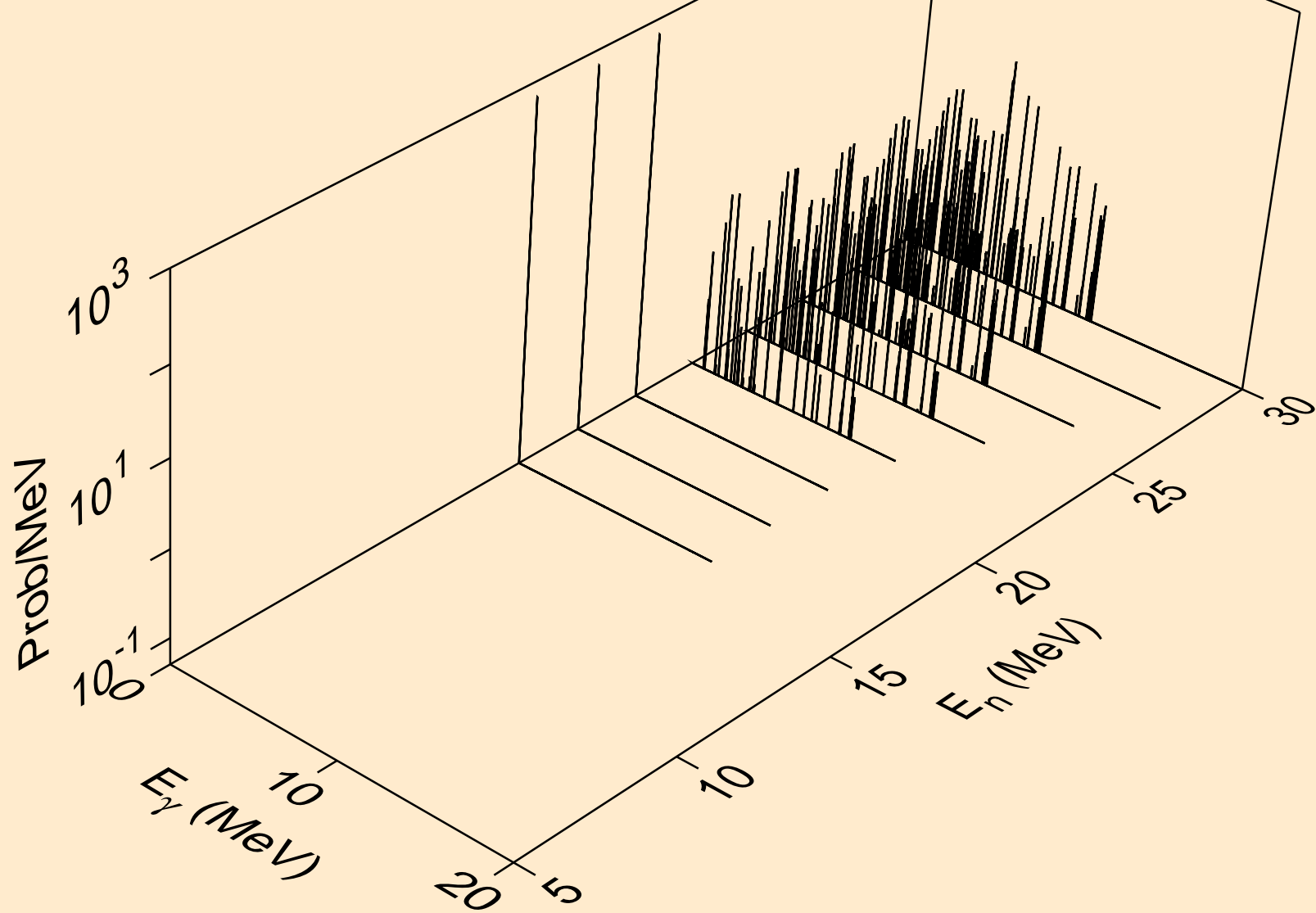

F017 PROTON ACER TENDL-2024 LIBRARY; T=0.K
Photon emission for (n,a)

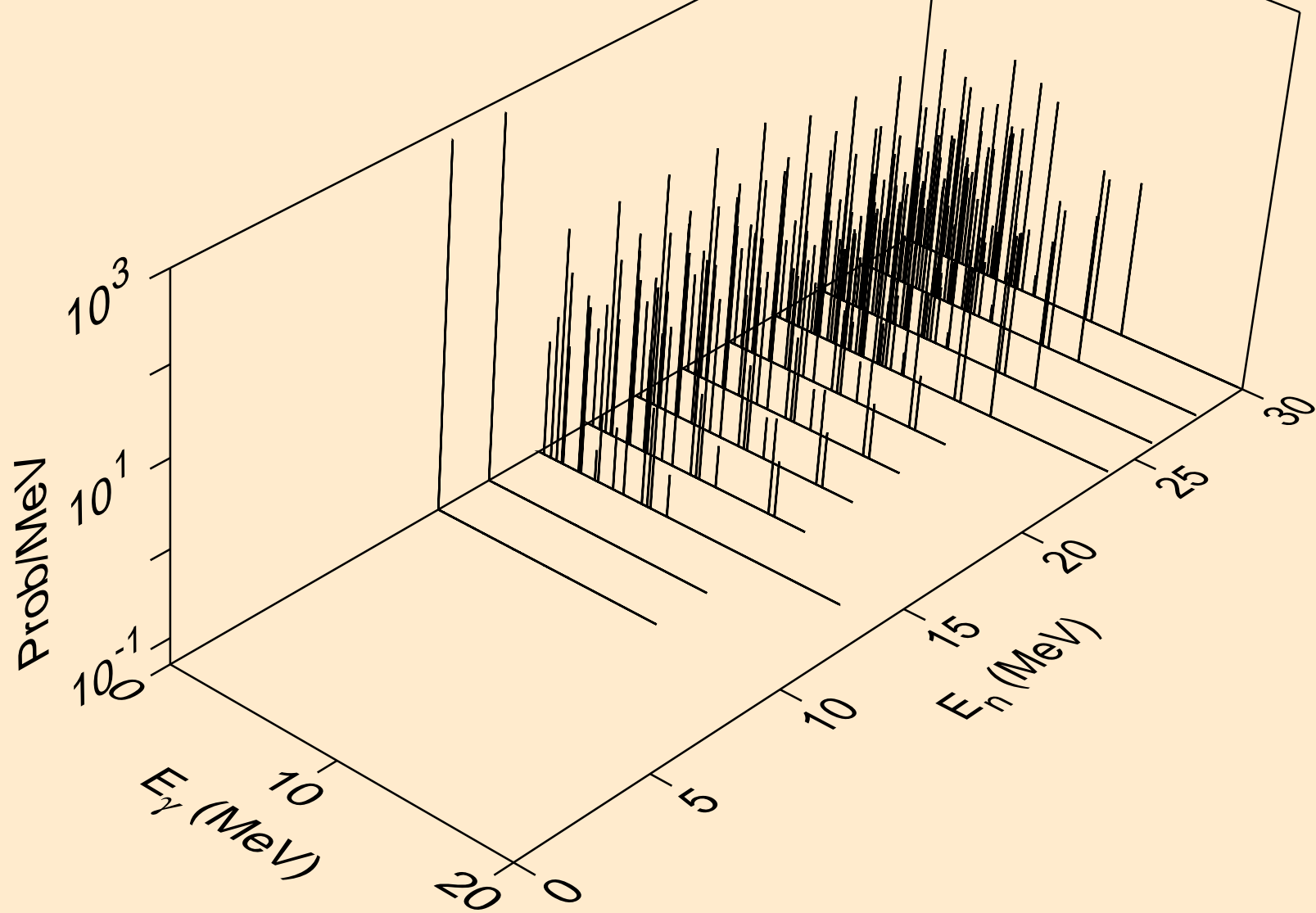

F017 PROTON ACER TENDL-2024 LIBRARY; T=0.K
Photon emission for (n,2a)

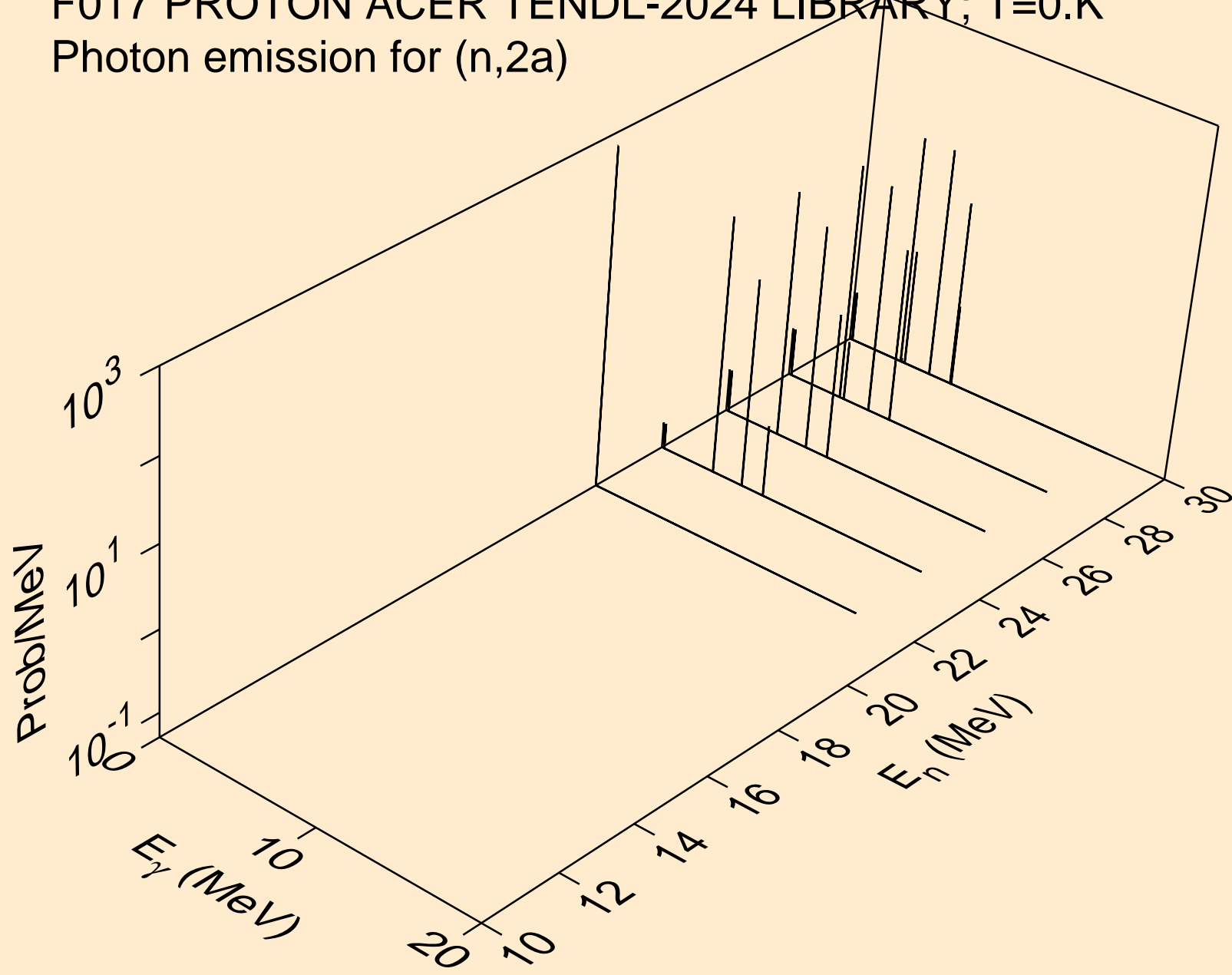

F017 PROTON ACER TENDL-2024 LIBRARY; T=0.K
Photon emission for (n,2p)

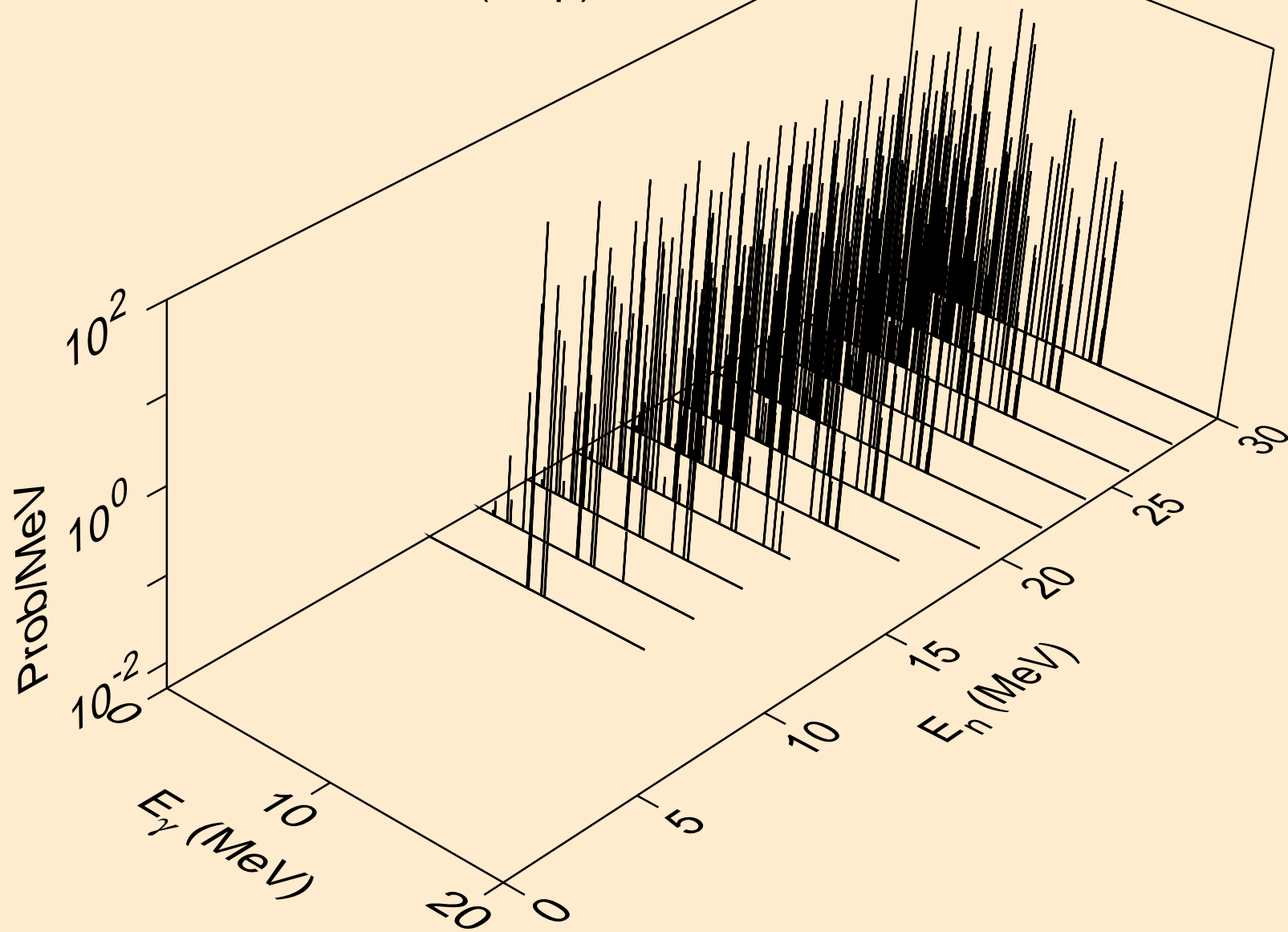

F017 PROTON ACER TENDL-2024 LIBRARY; T=0.K
Photon emission for (n,pa)

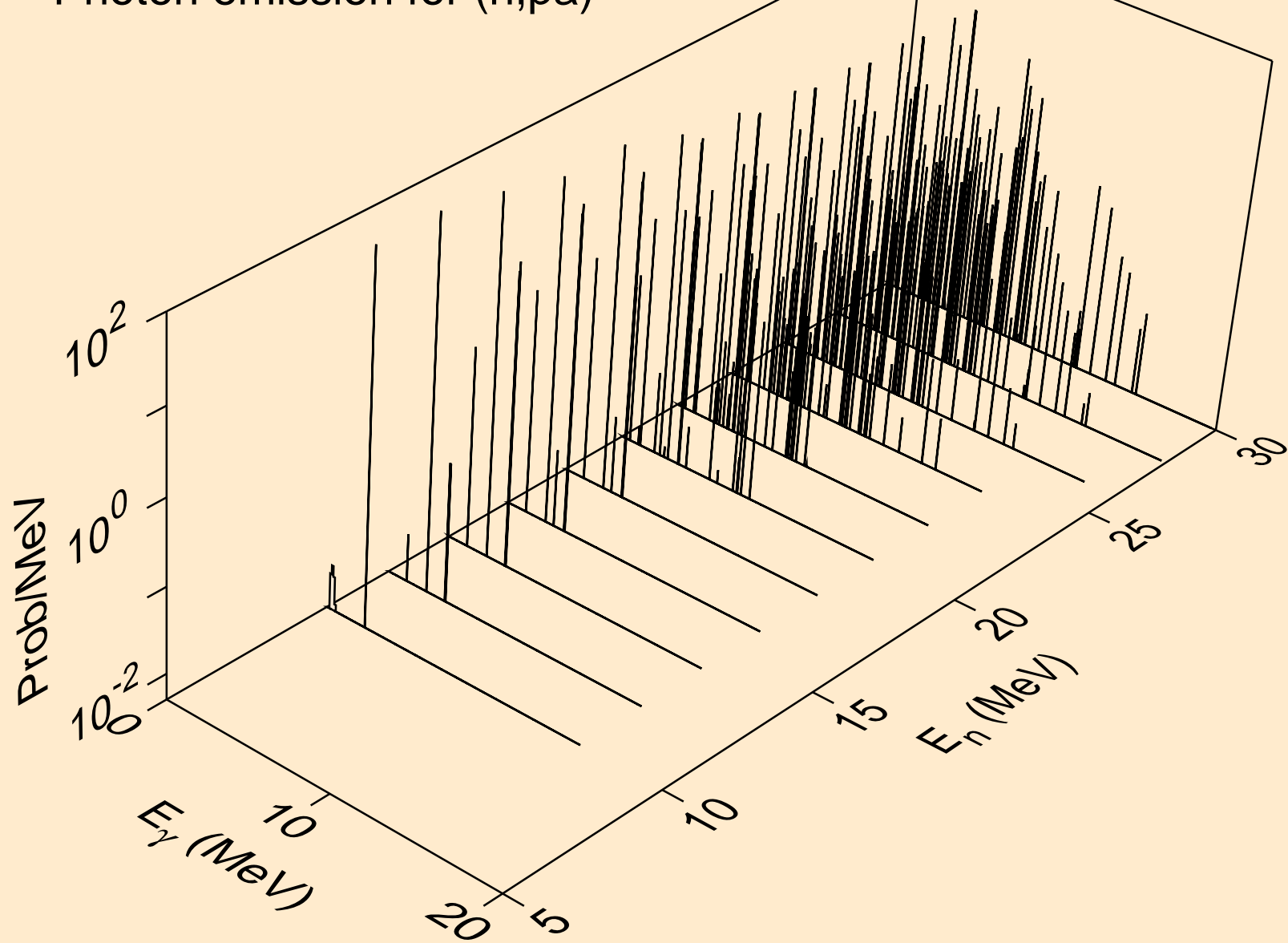

F017 PROTON ACER TENDL-2024 LIBRARY; T=0.K
Photon emission for (n,pd)

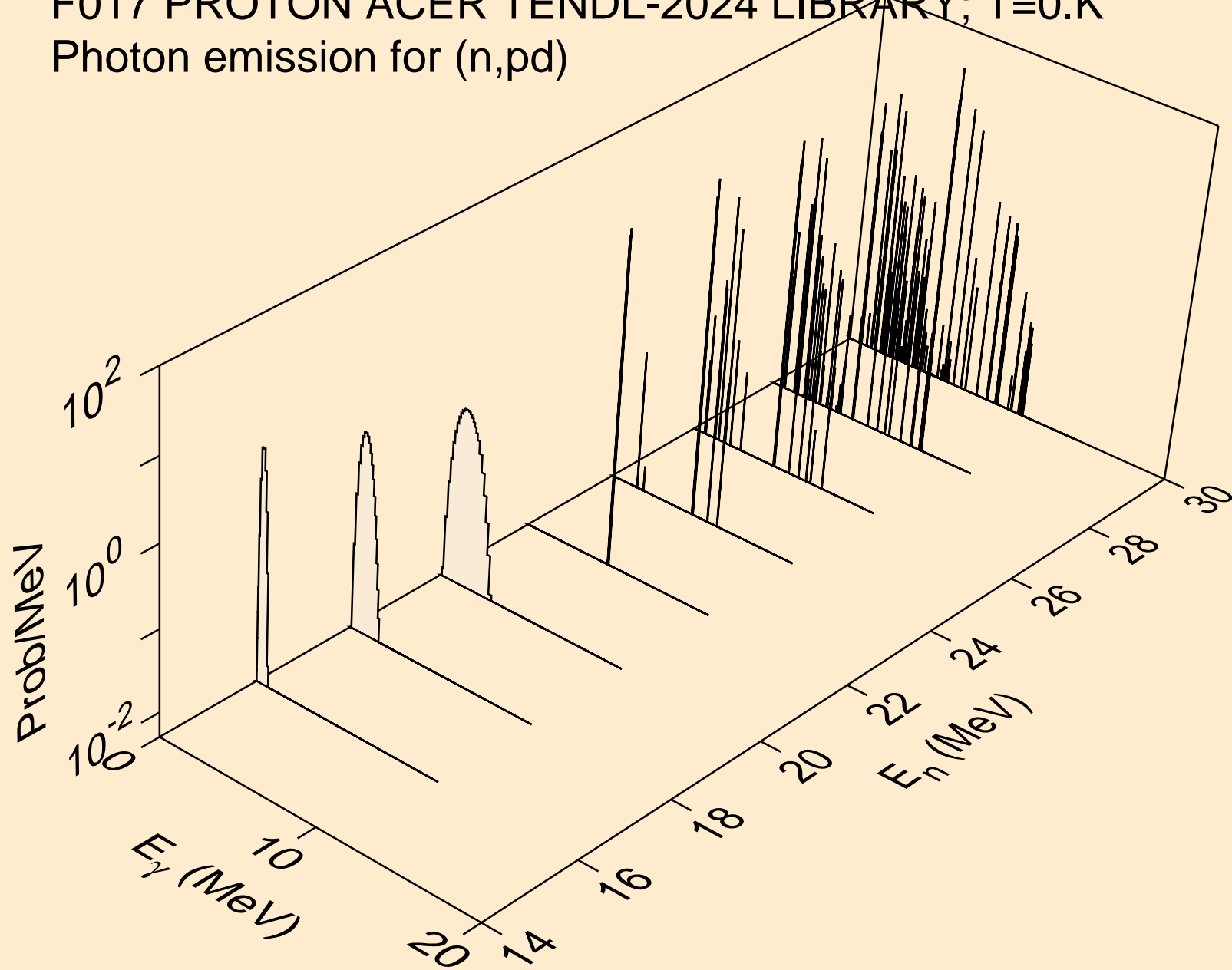

F017 PROTON ACER TENDL-2024 LIBRARY; T=0.K
Photon emission for (n,pt)

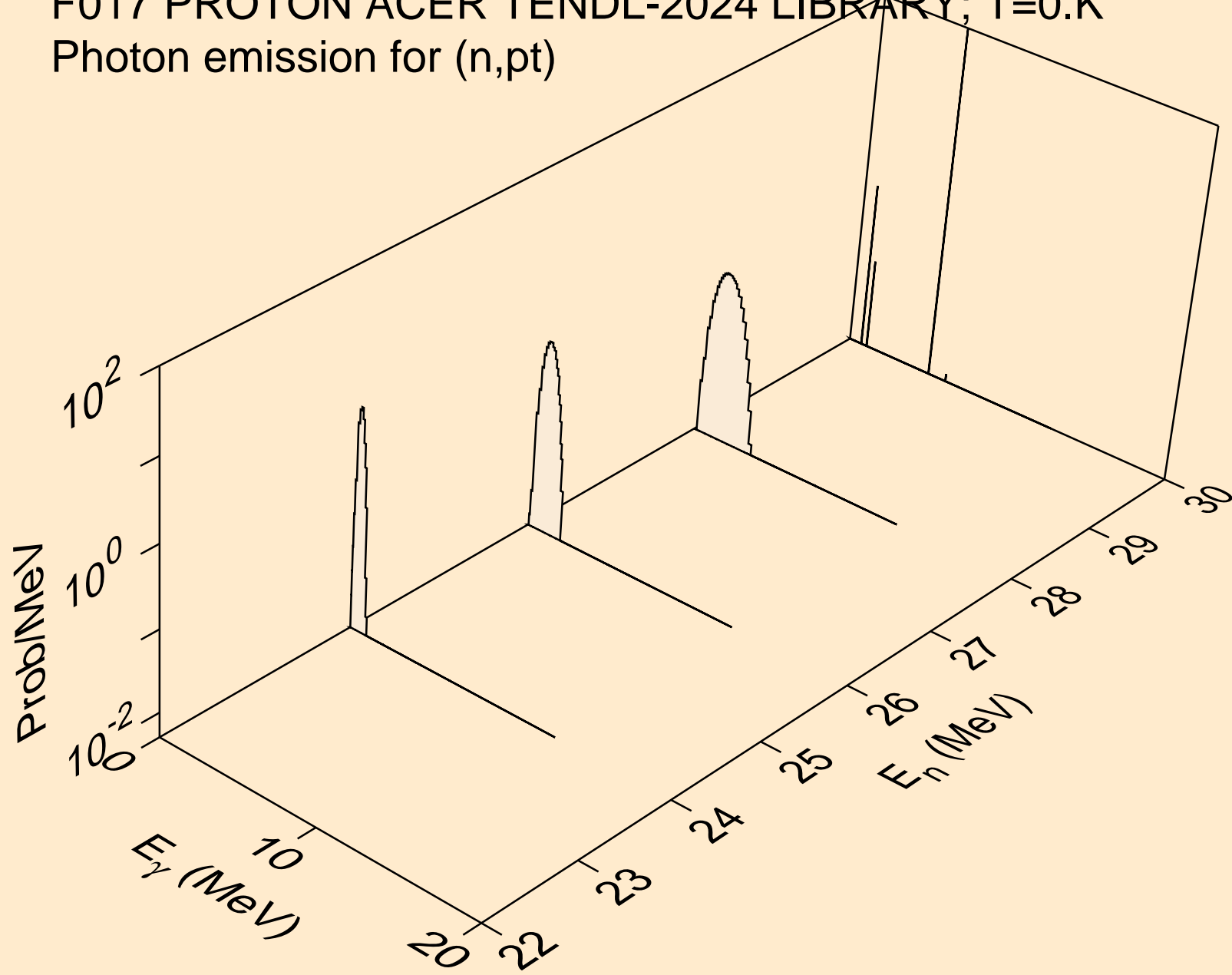

F017 PROTON ACER TENDL-2024 LIBRARY; T=0.K
Photon emission for (n,da)

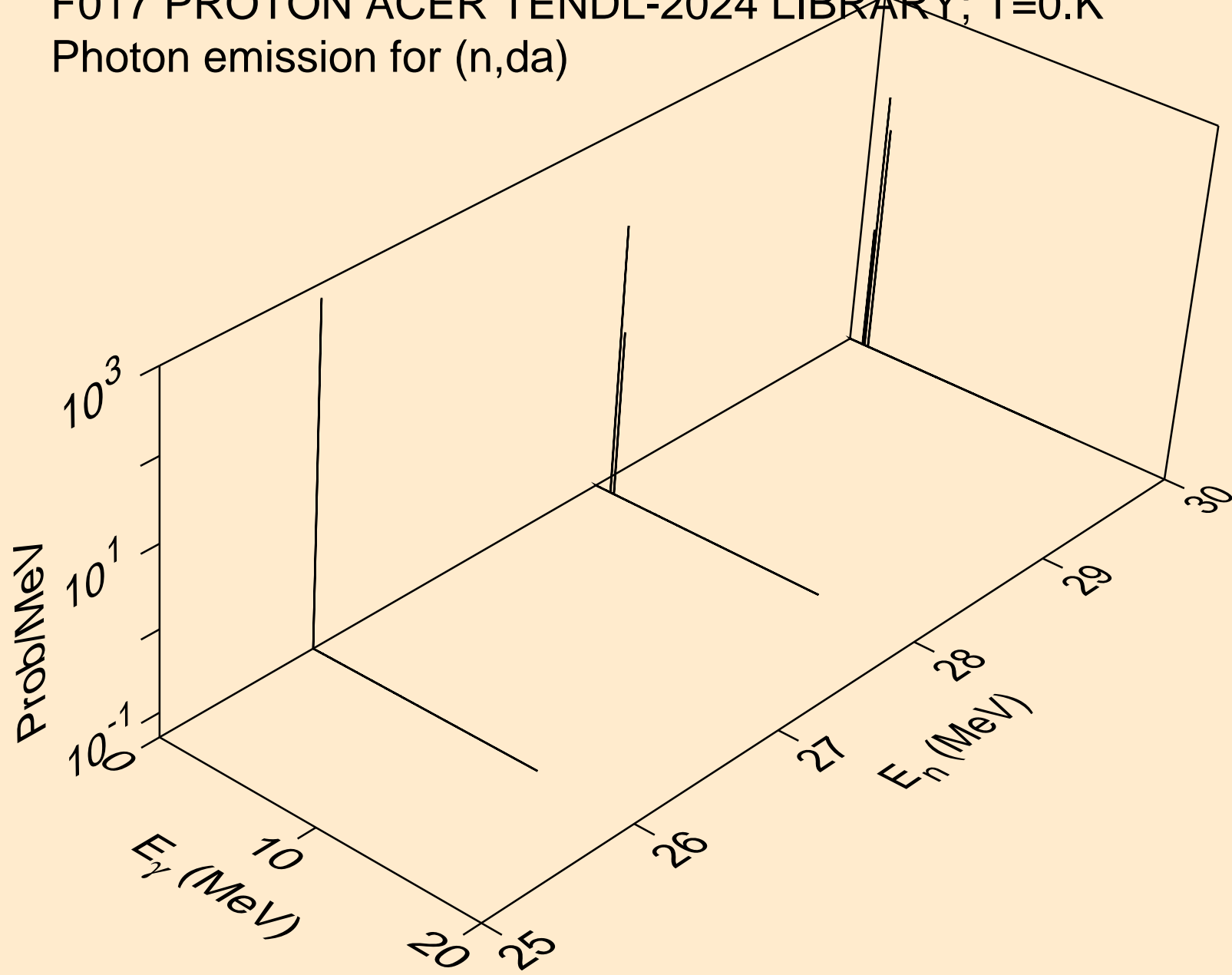

F017 PROTON ACER TENDL-2024 LIBRARY; T=0.K

Particle heating contributions

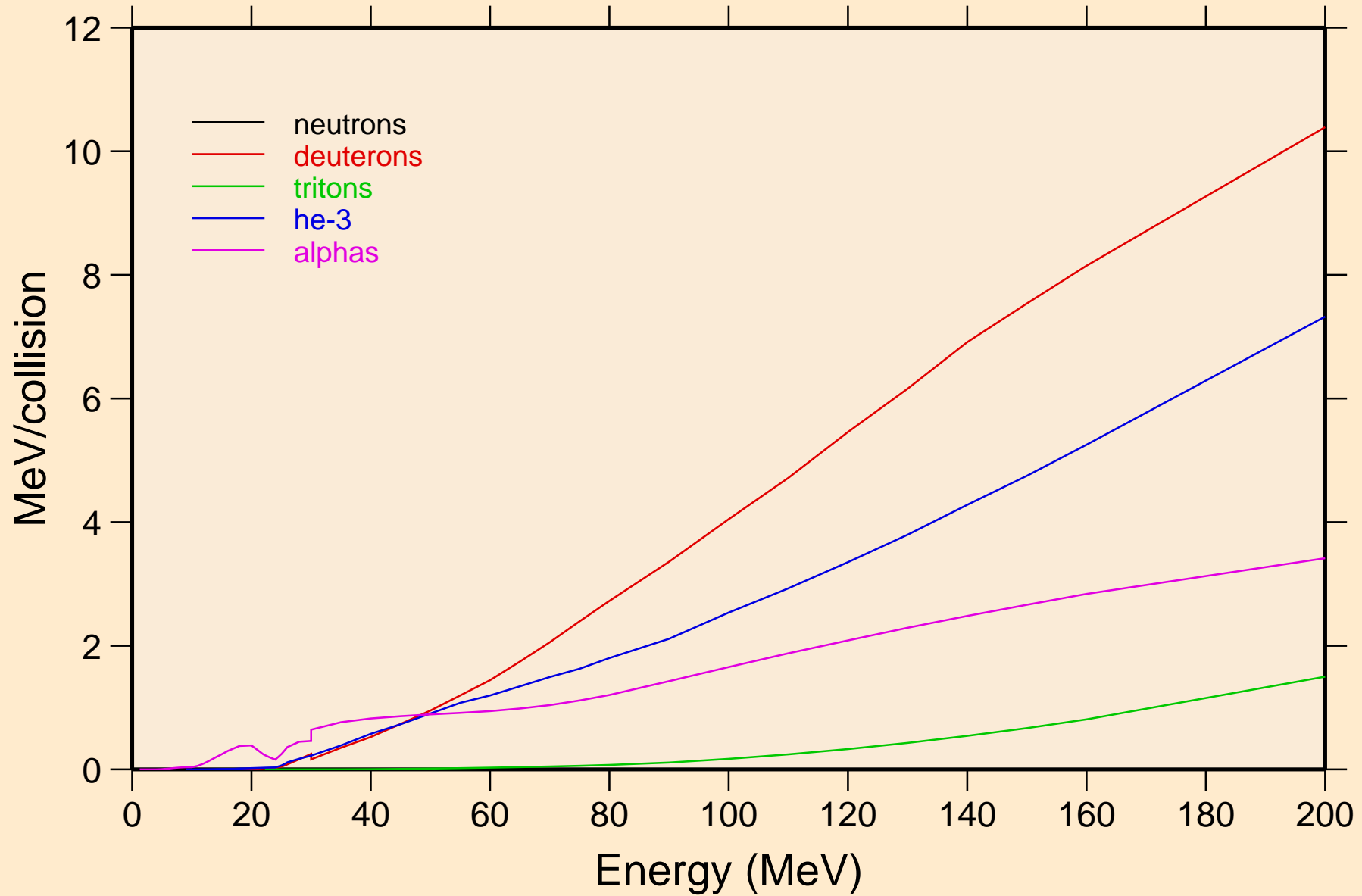

F017 PROTON ACER TENDL-2024 LIBRARY; T=0.K
Recoil Heating

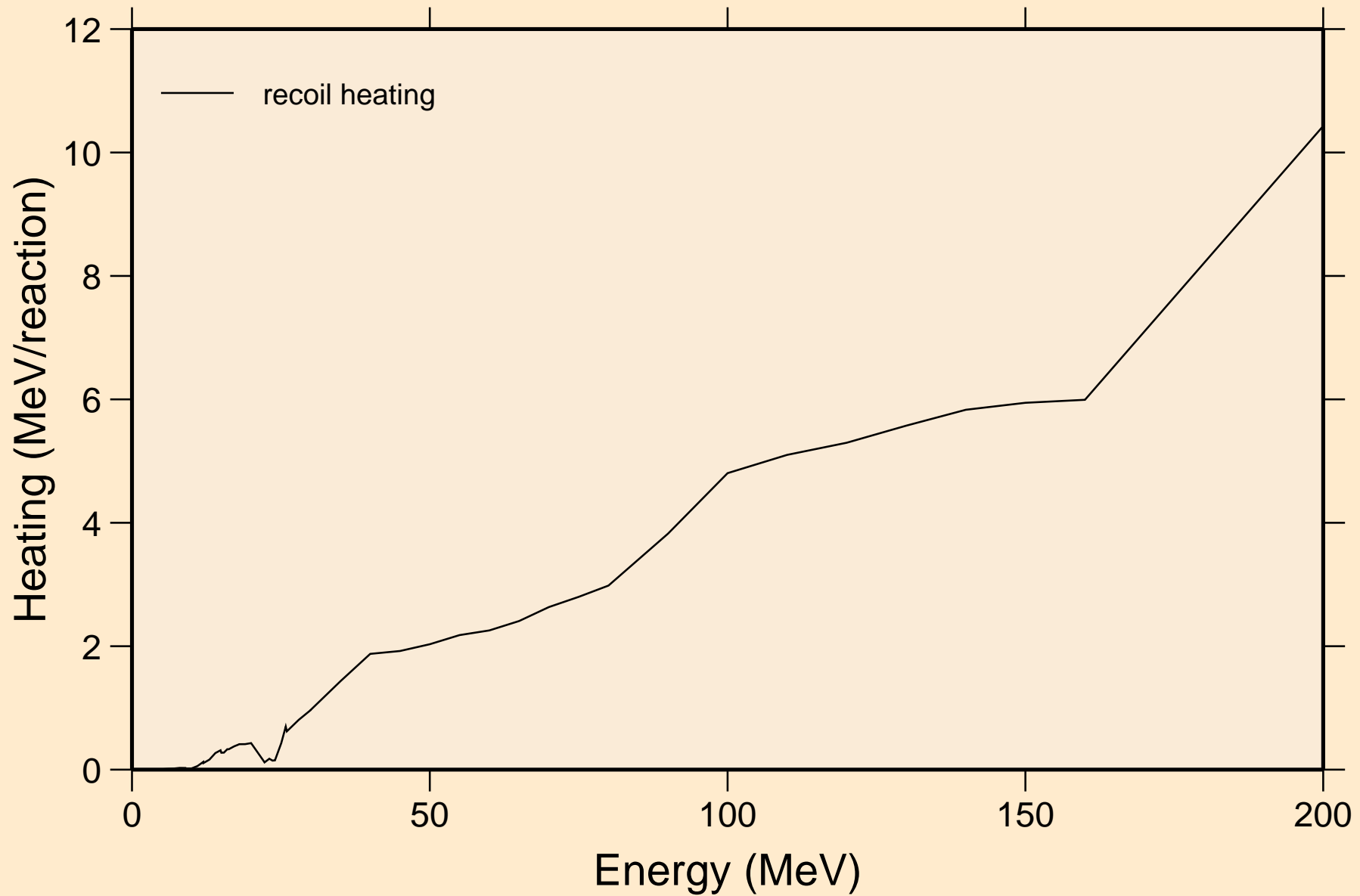

F017 PROTON ACER TENDL-2024 LIBRARY; T=0.K

Particle production cross sections

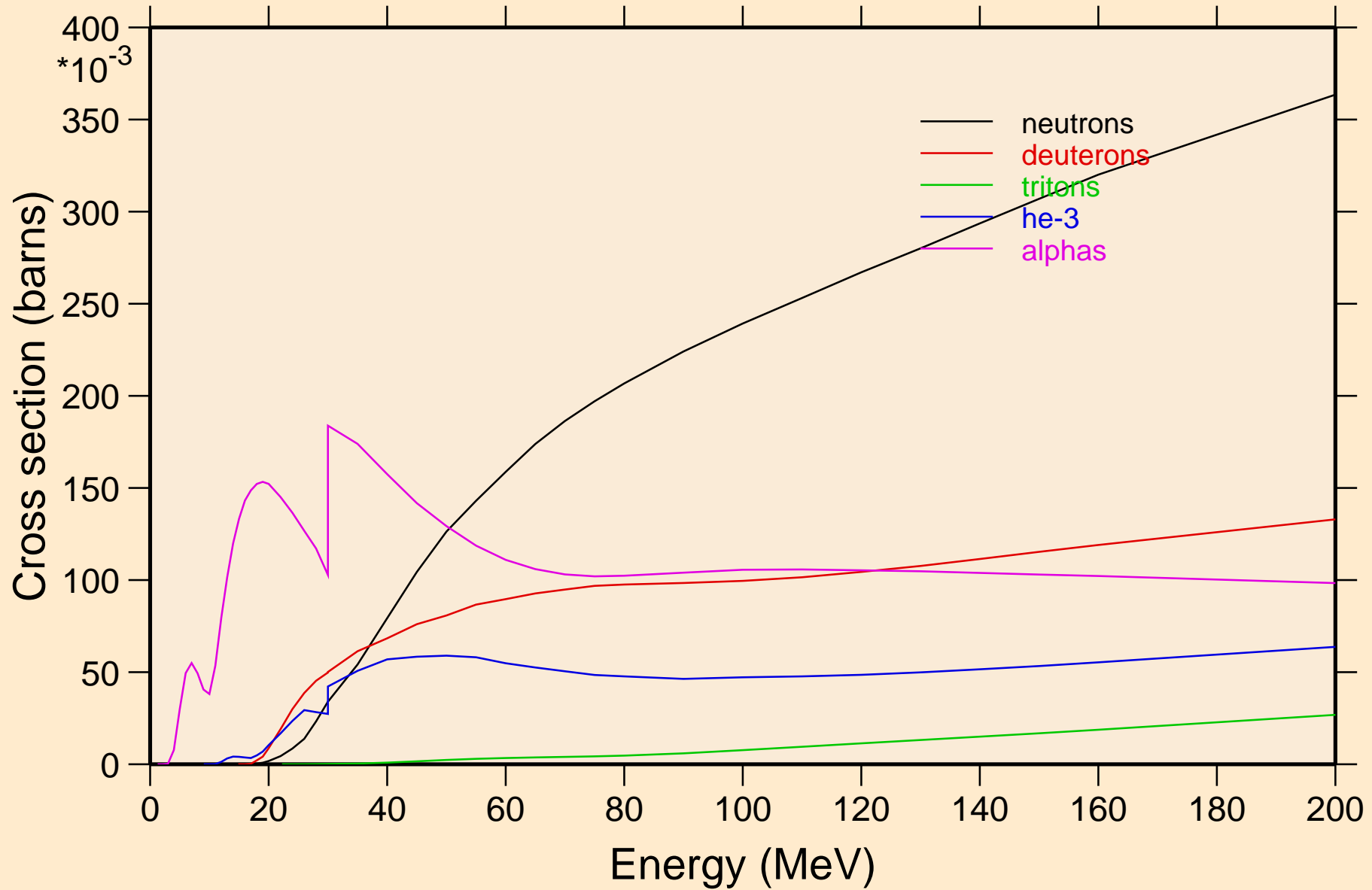

F017 PROTON ACER TENDL-2024 LIBRARY; T=0.K
neutrons from (p,n)

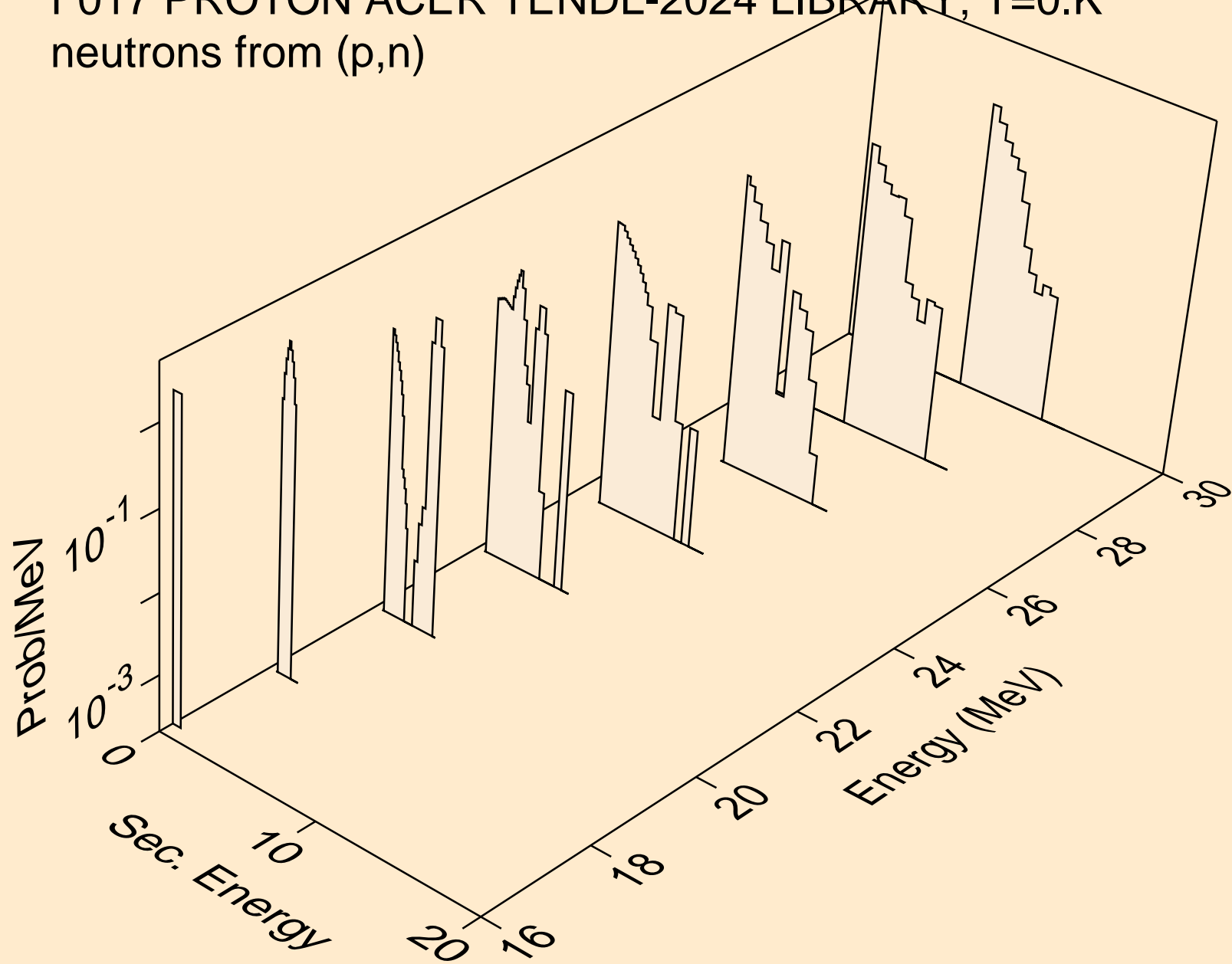

F017 PROTON ACER TENDL-2024 LIBRARY; T=0.K
neutrons from (p,x)

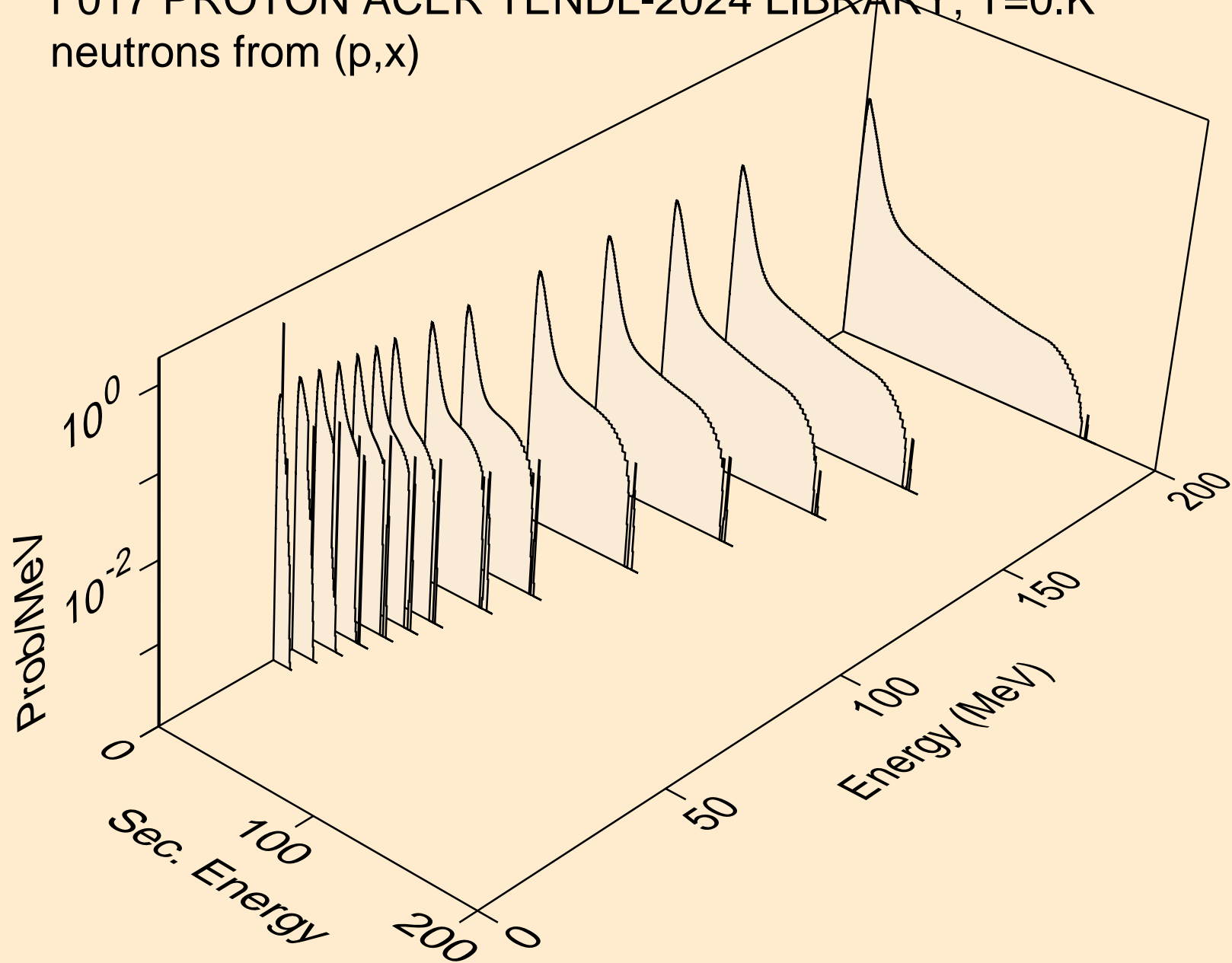

F017 PROTON ACER TENDL-2024 LIBRARY; T=0.K
neutrons from (p,n*)a

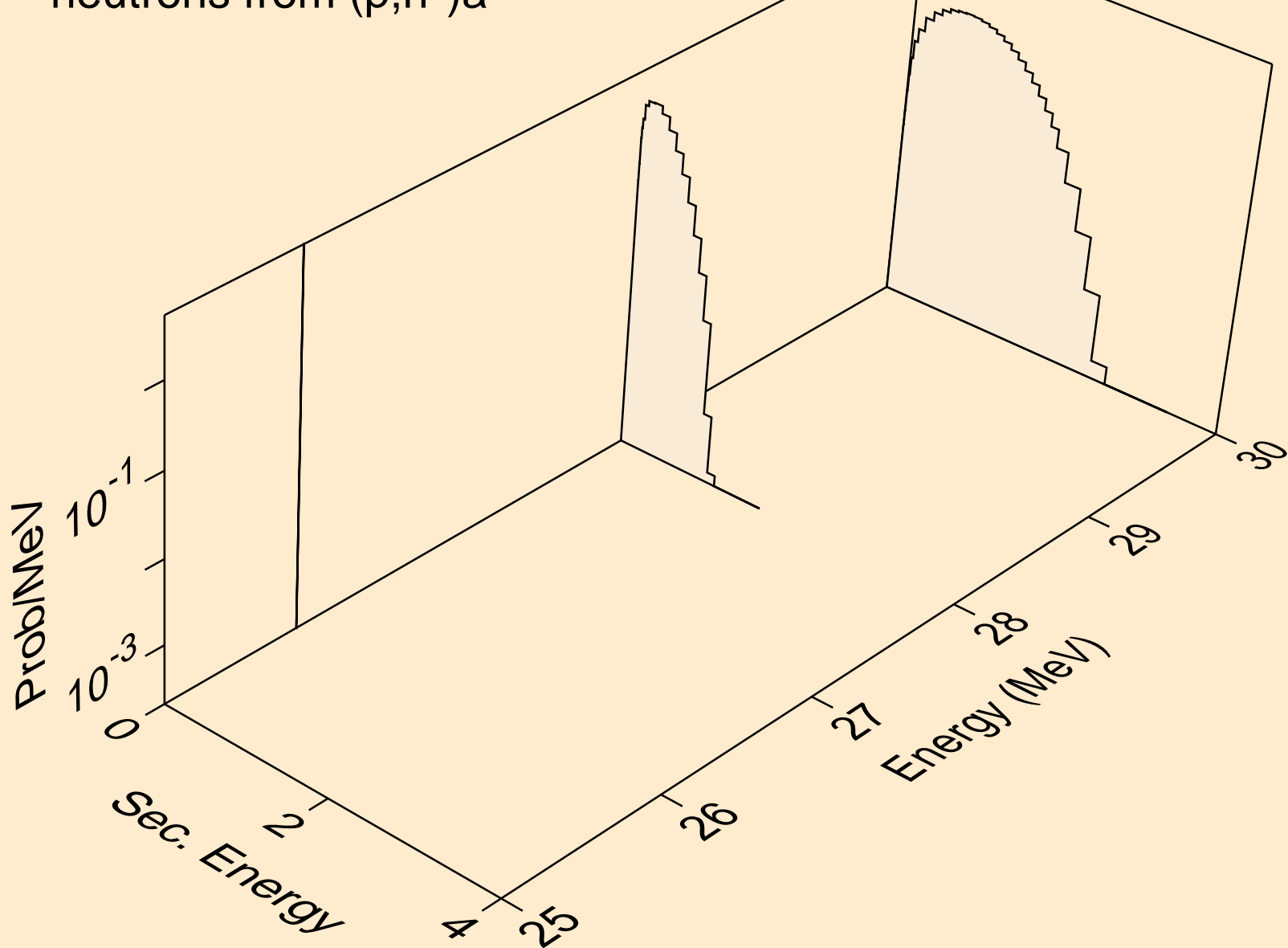

F017 PROTON ACER TENDL-2024 LIBRARY; T=0.K
neutrons from (p,n*)p

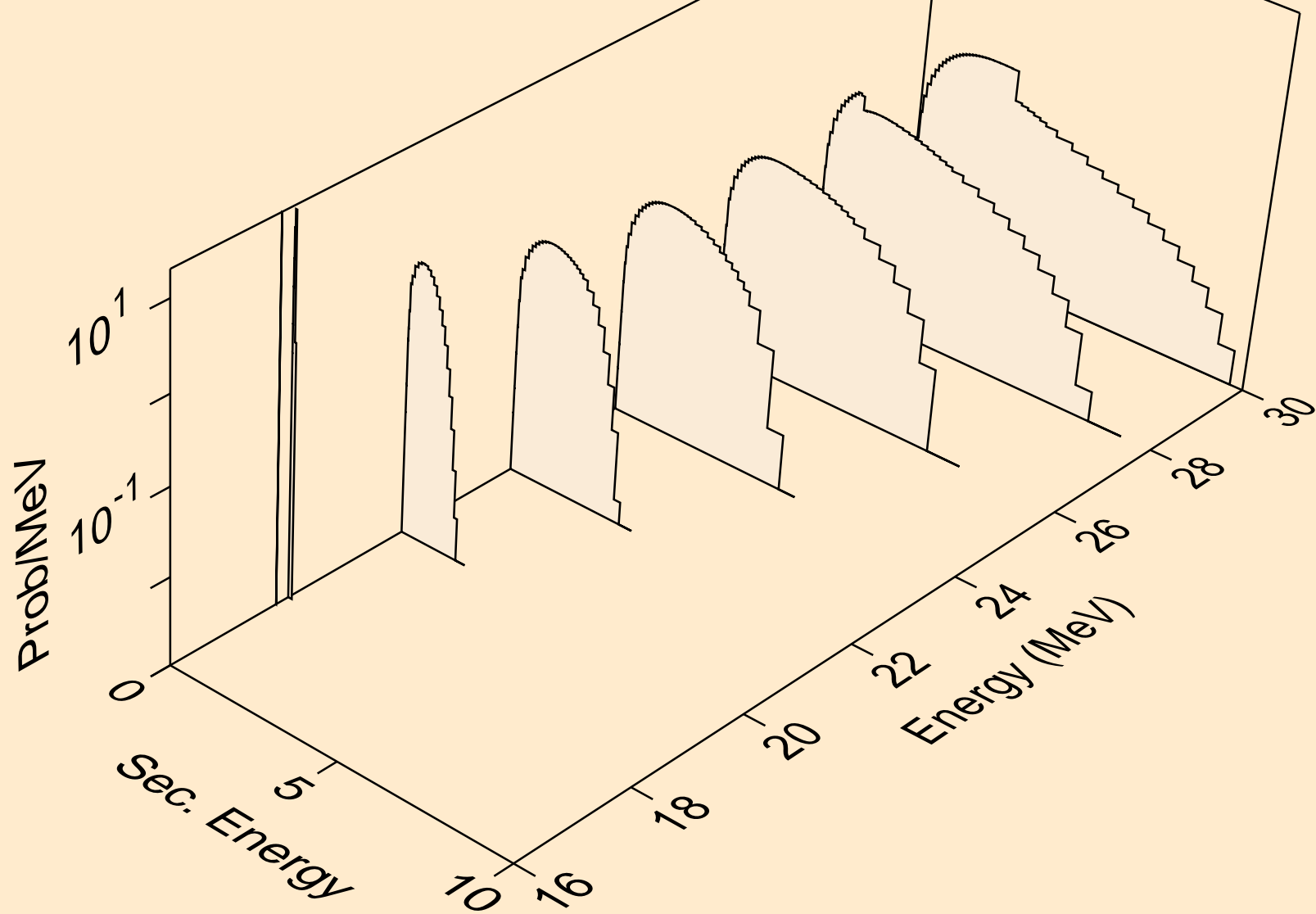

F017 PROTON ACER TENDL-2024 LIBRARY; T=0.K
neutrons from (p,n*)he3

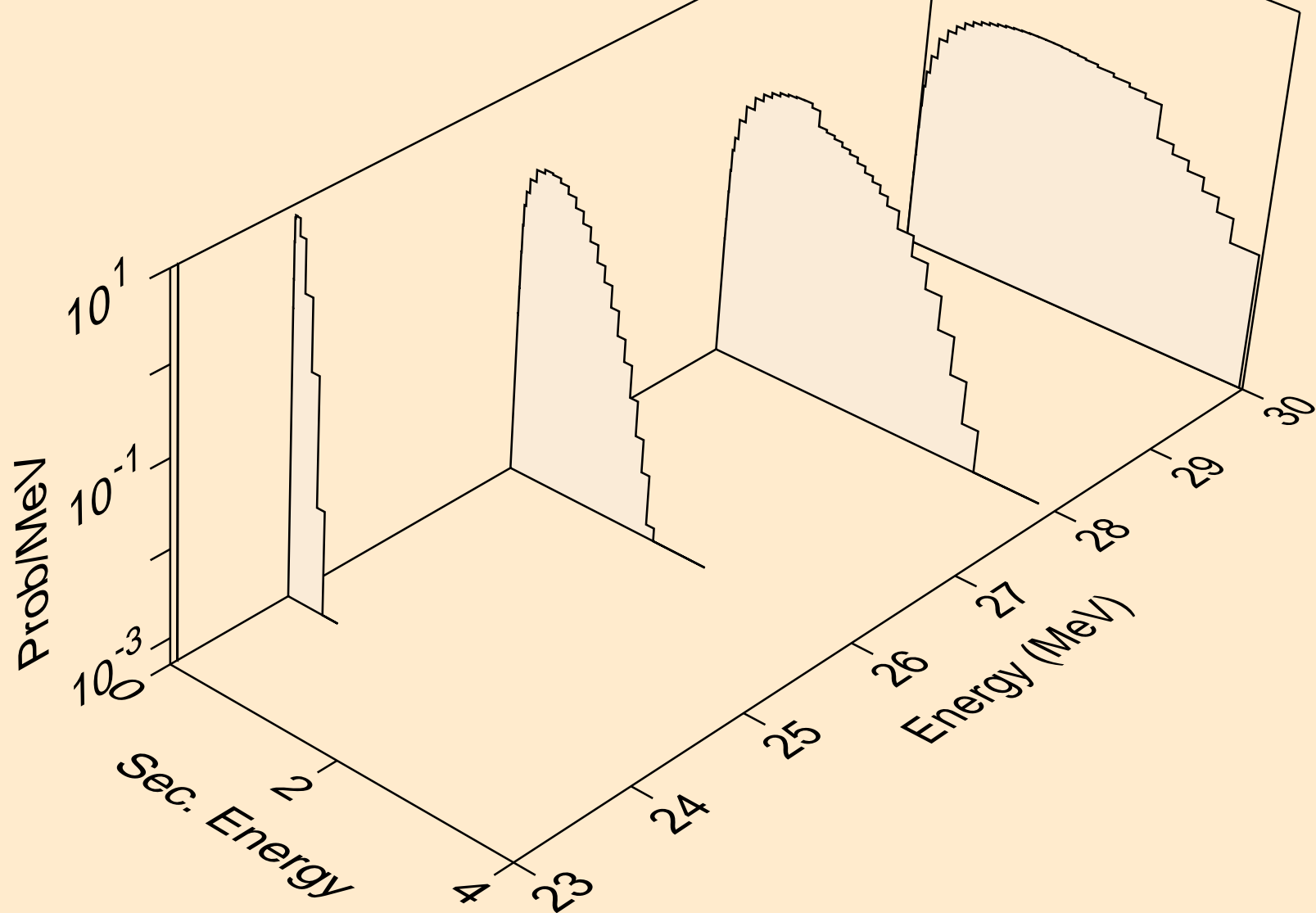

F017 PROTON ACER TENDL-2024 LIBRARY; T=0.K
neutrons from (p,n2p)

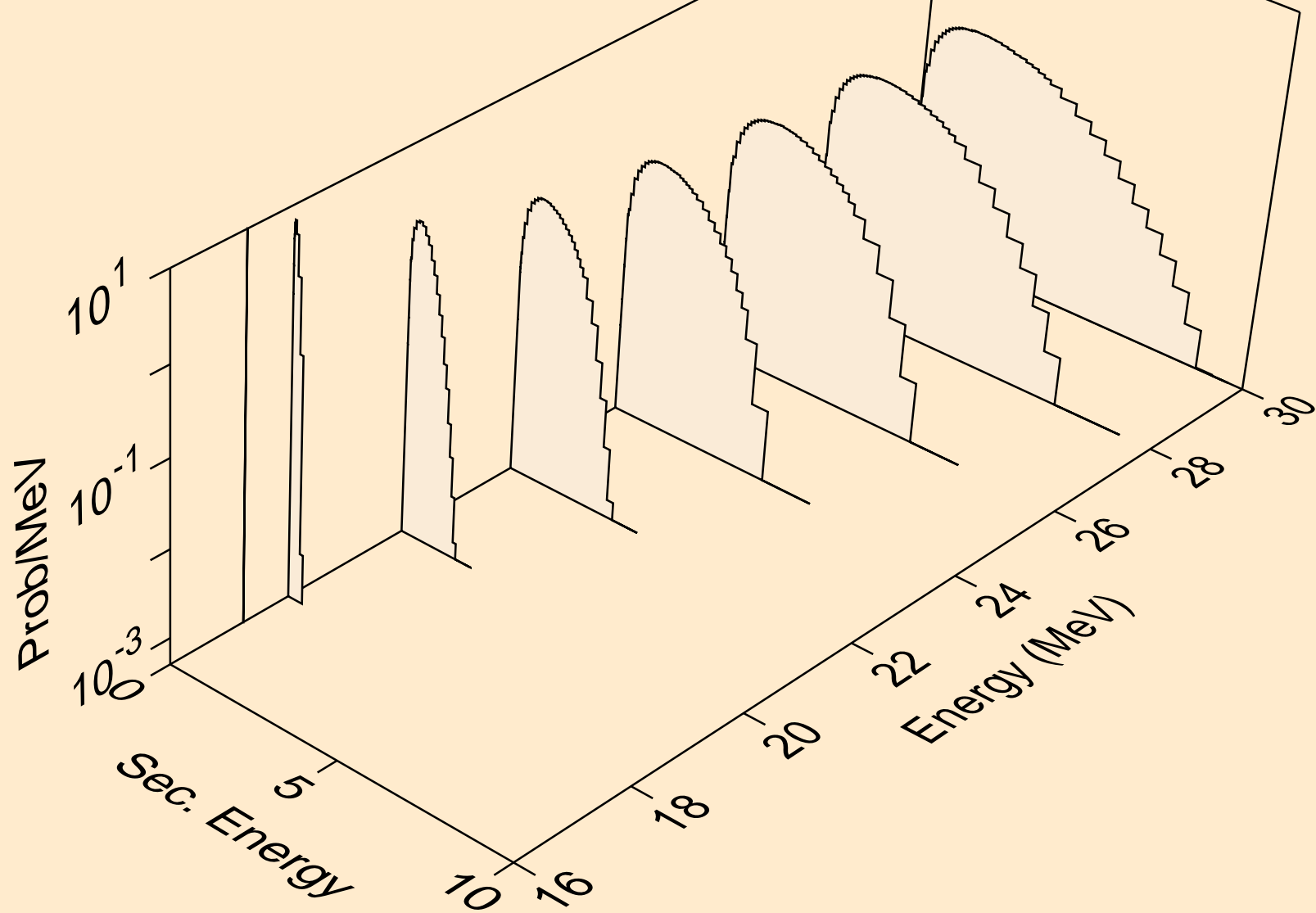

F017 PROTON ACER TENDL-2024 LIBRARY; T=0.K
deuterons from (p,x)

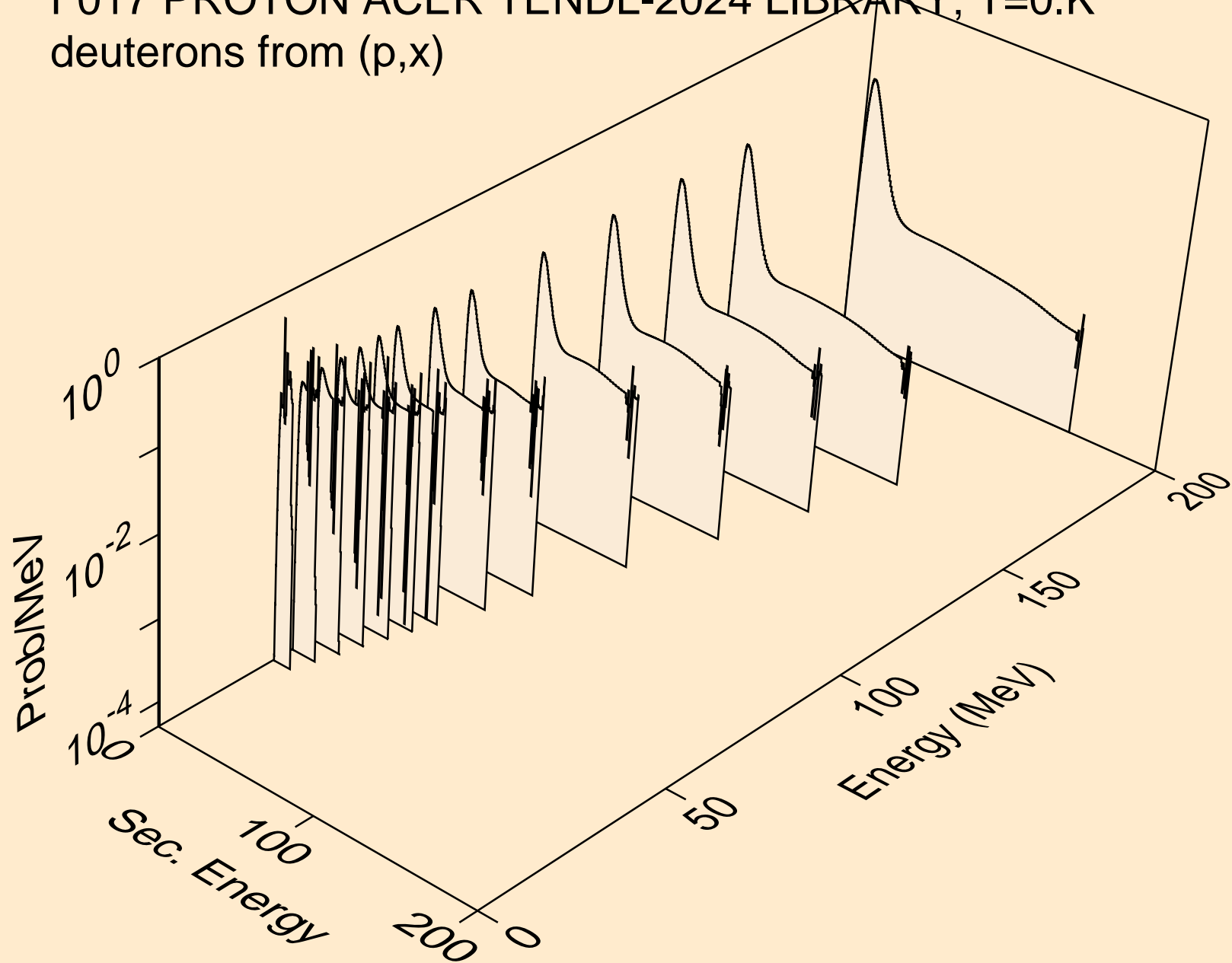

F017 PROTON ACER TENDL-2024 LIBRARY; T=0.K
deuterons from (p,d)

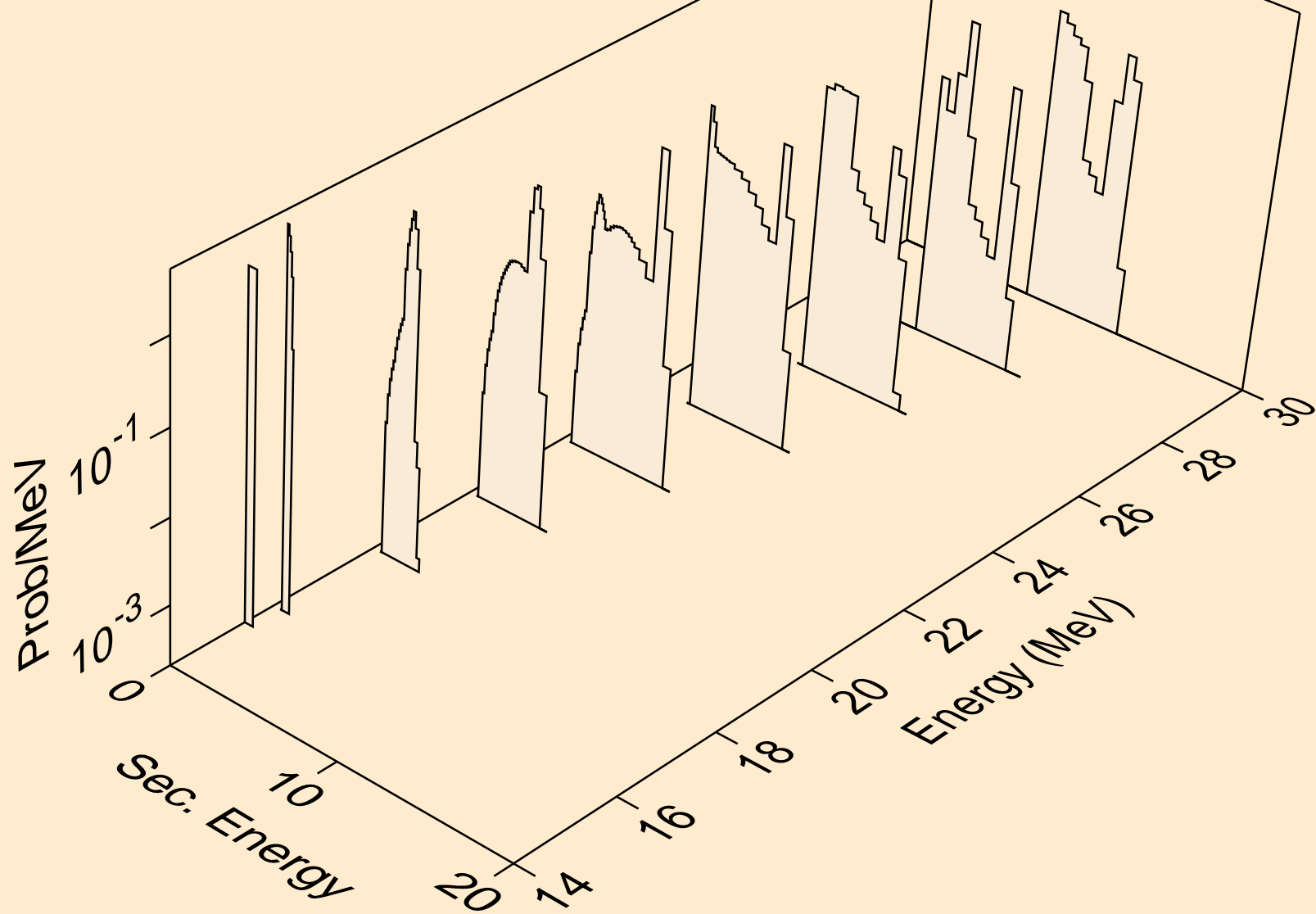

F017 PROTON ACER TENDL-2024 LIBRARY; T=0.K
deuterons from (p,pd)

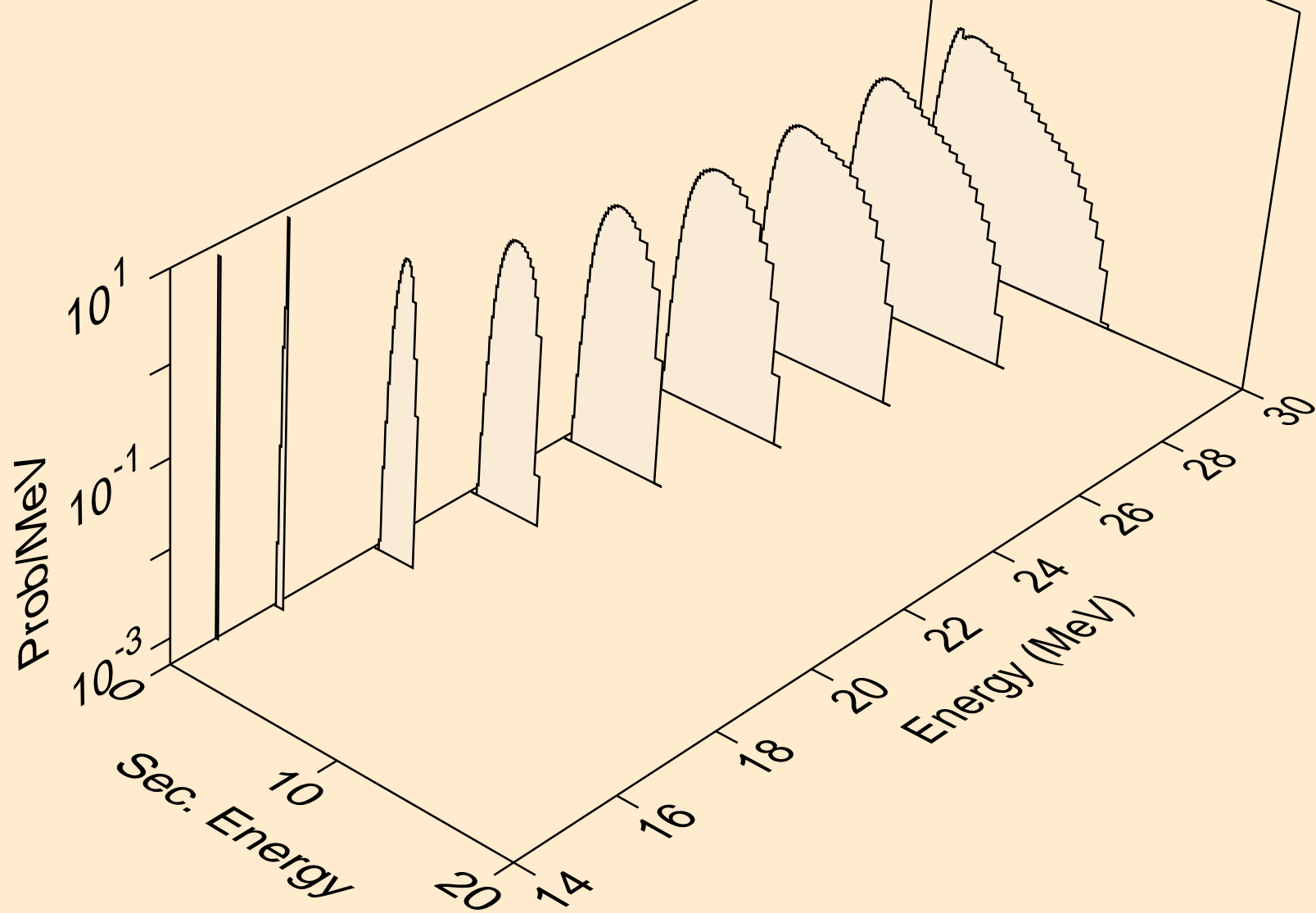

F017 PROTON ACER TENDL-2024 LIBRARY; T=0.K
deuterons from (p,da)

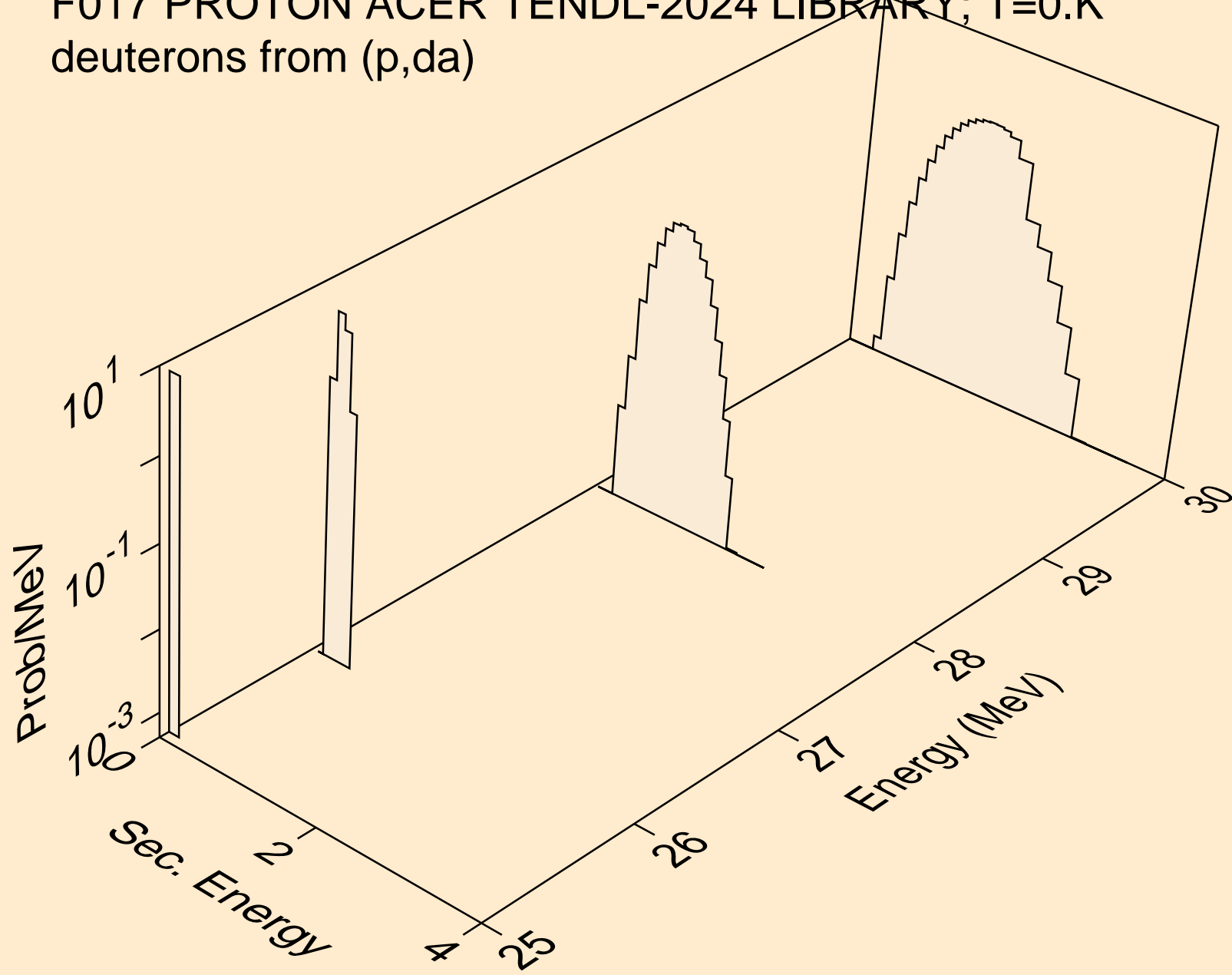

F017 PROTON ACER TENDL-2024 LIBRARY; T=0.K
tritons from (p,x)

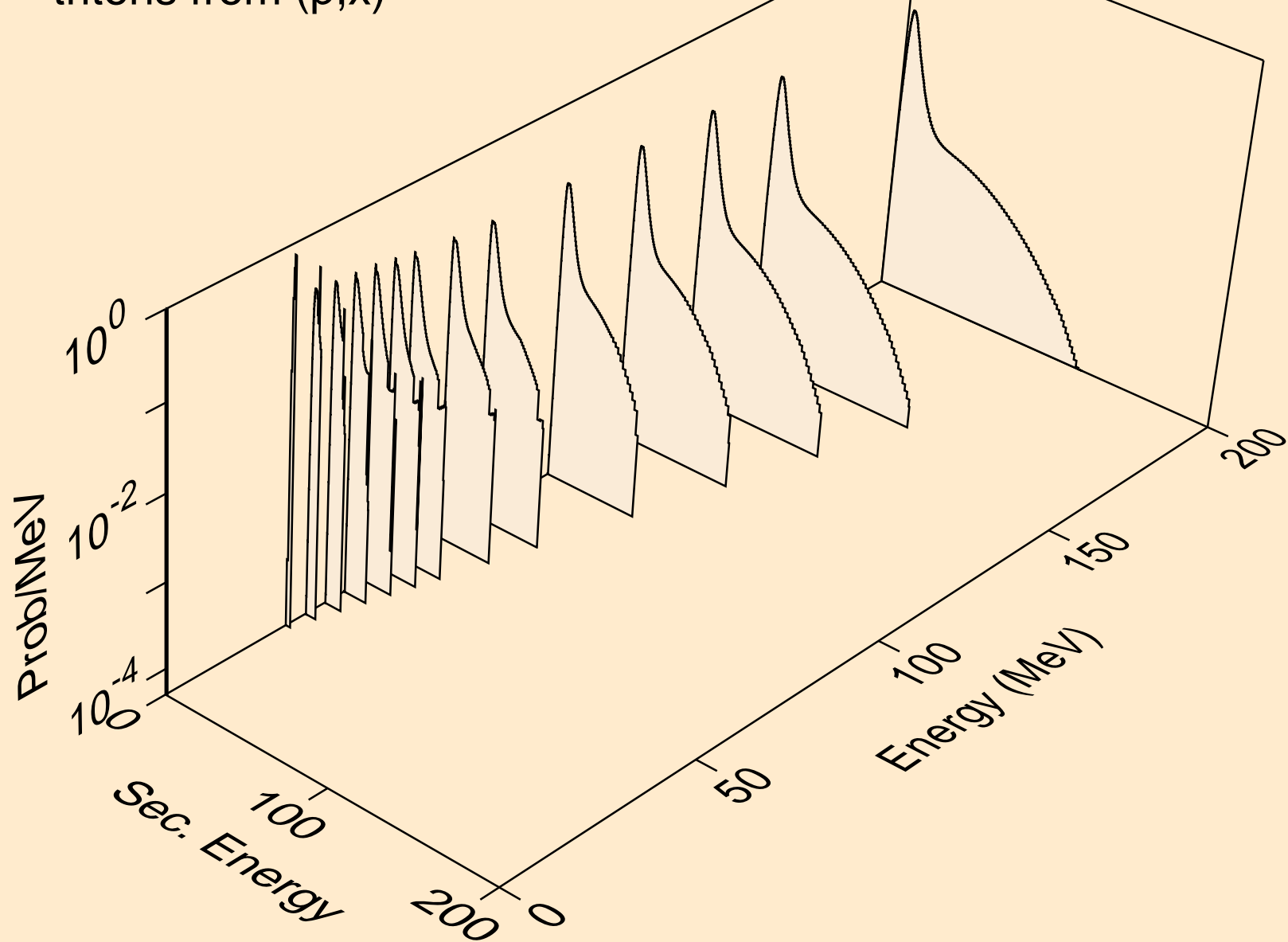

F017 PROTON ACER TENDL-2024 LIBRARY; T=0.K
tritons from (p,t)

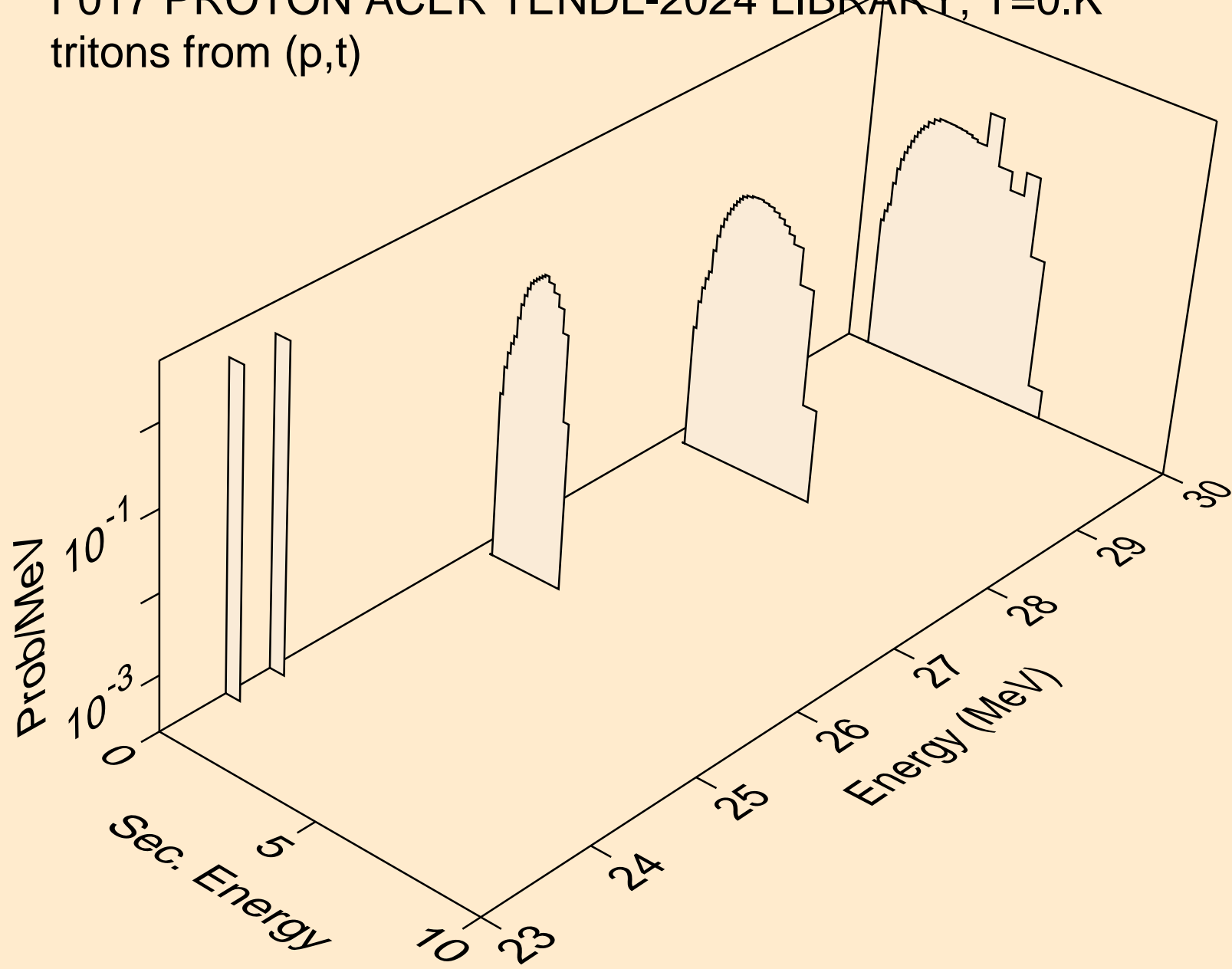

F017 PROTON ACER TENDL-2024 LIBRARY; T=0.K
tritons from (p,pt)

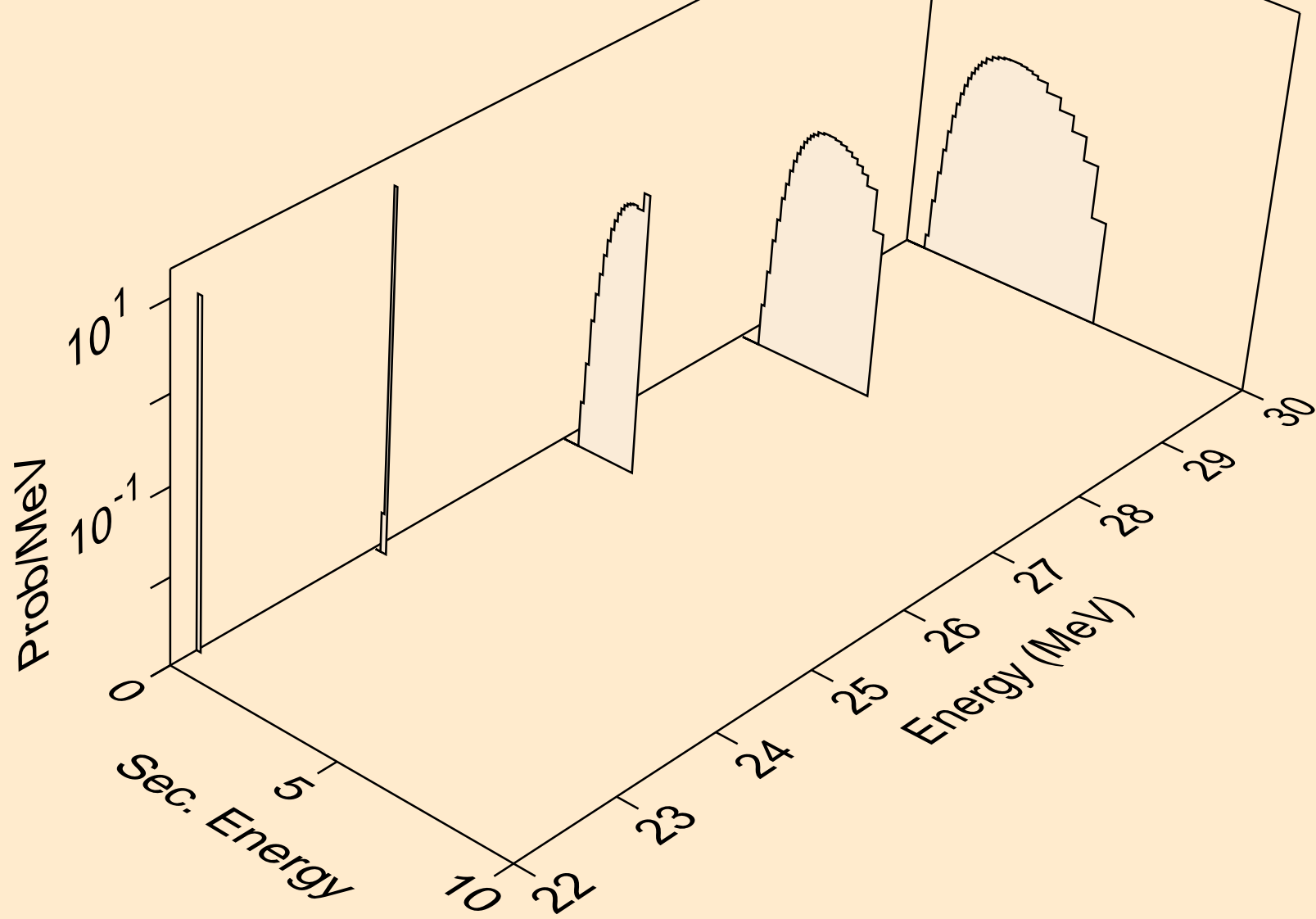

F017 PROTON ACER TENDL-2024 LIBRARY; T=0.K
he3s from (p,x)

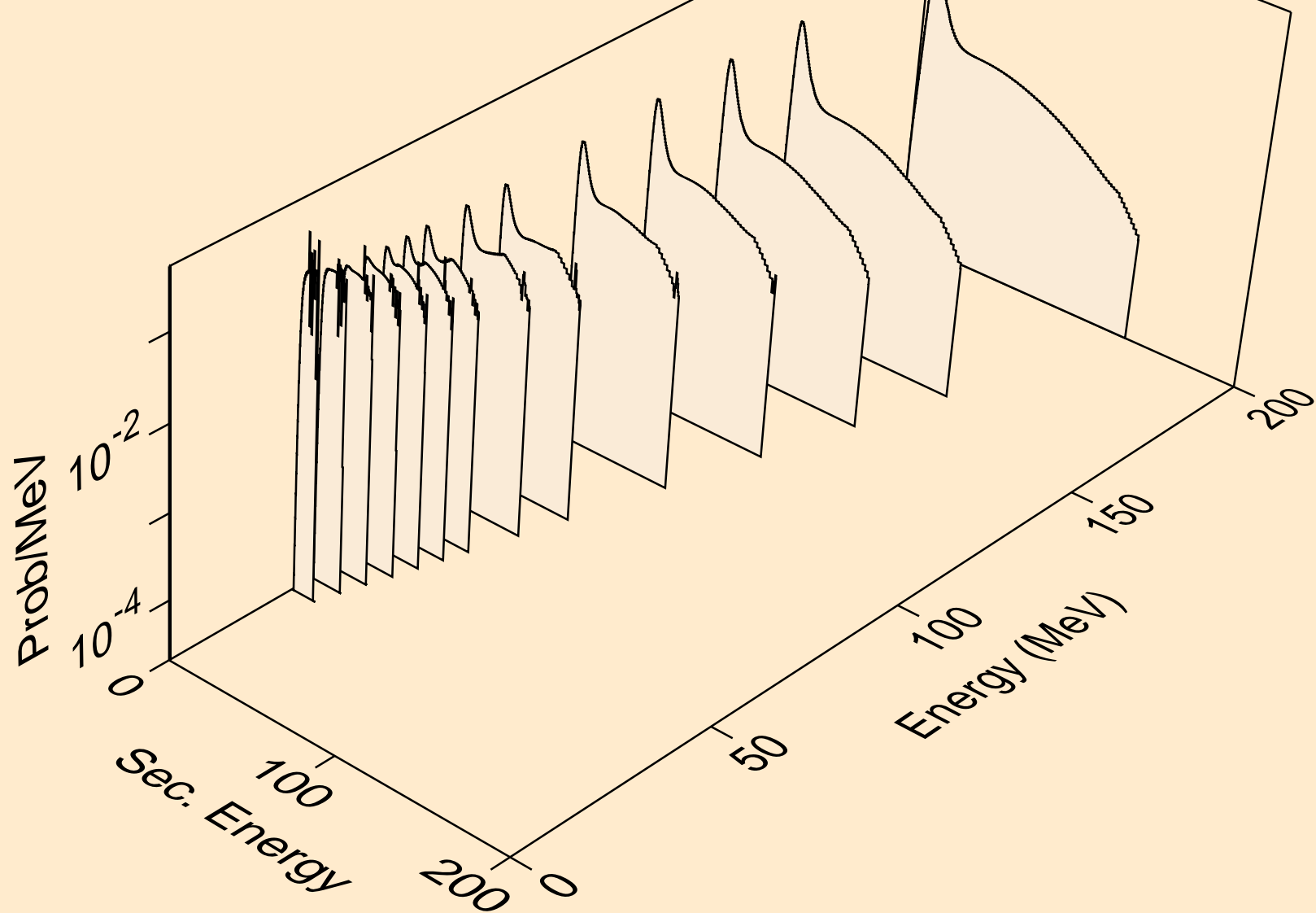

F017 PROTON ACER TENDL-2024 LIBRARY; T=0.K
he3s from (p,n*)he3

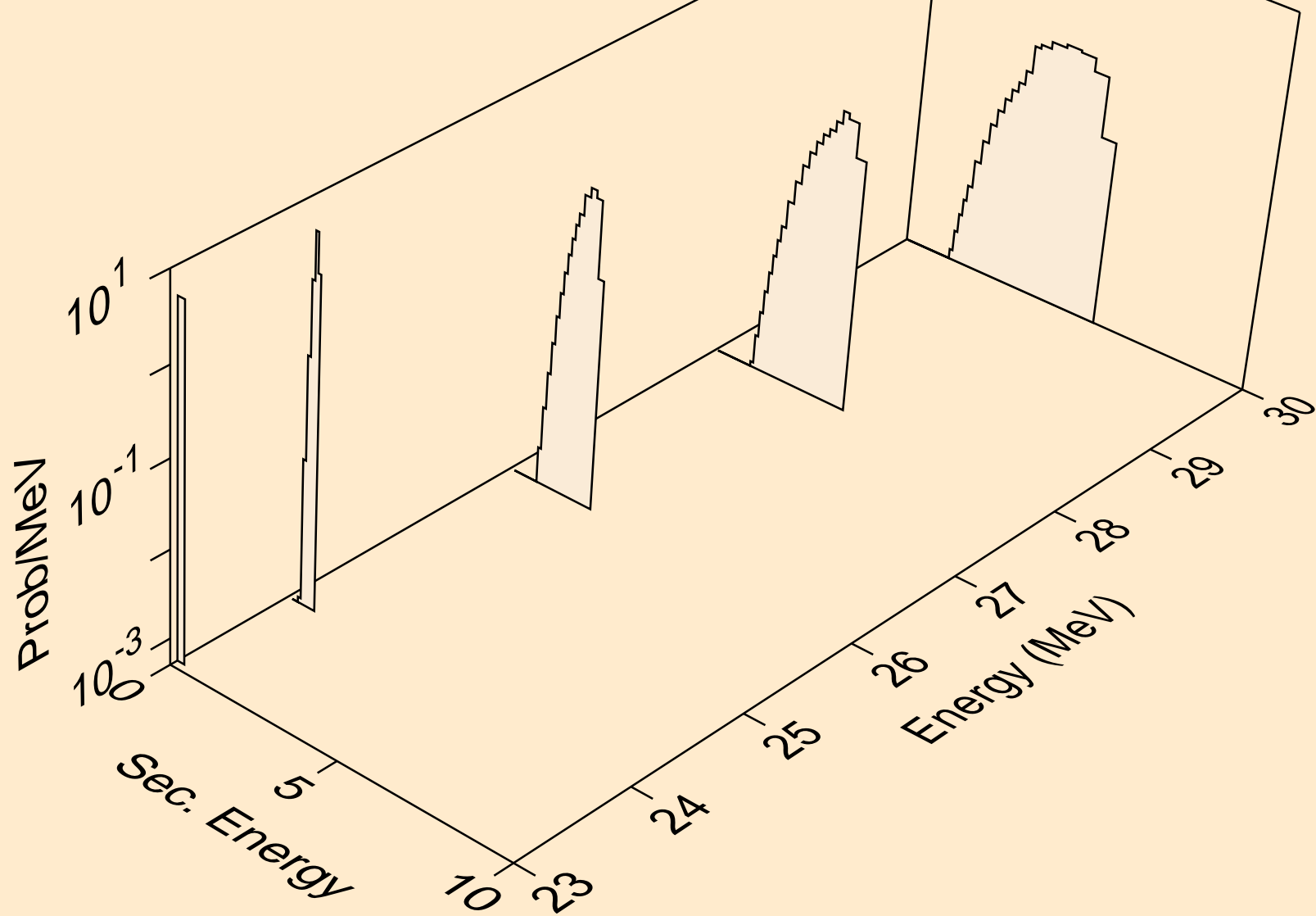

F017 PROTON ACER TENDL-2024 LIBRARY; T=0.K
he3s from (p,he3)

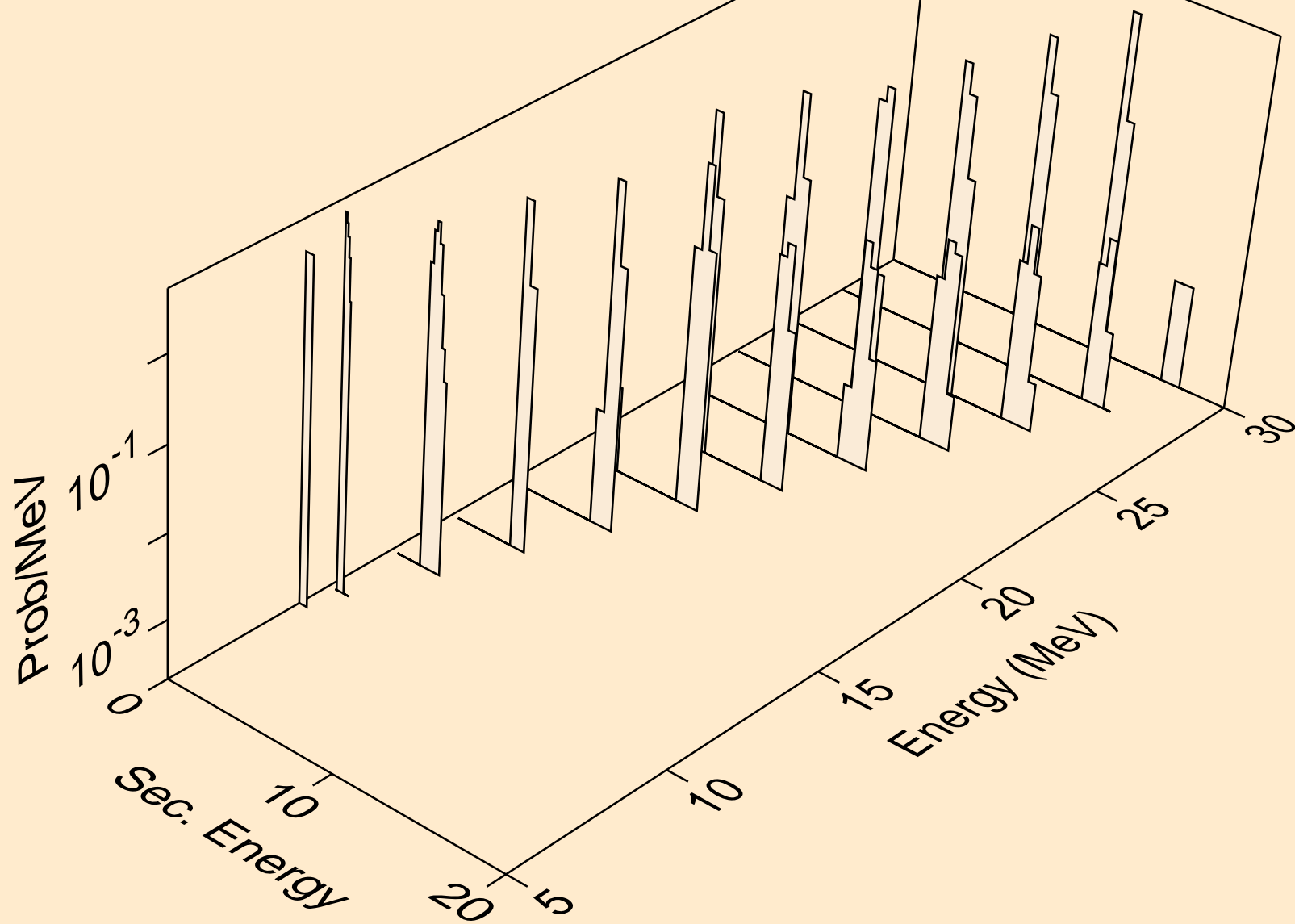

F017 PROTON ACER TENDL-2024 LIBRARY; T=0.K
alphas from (p,x)

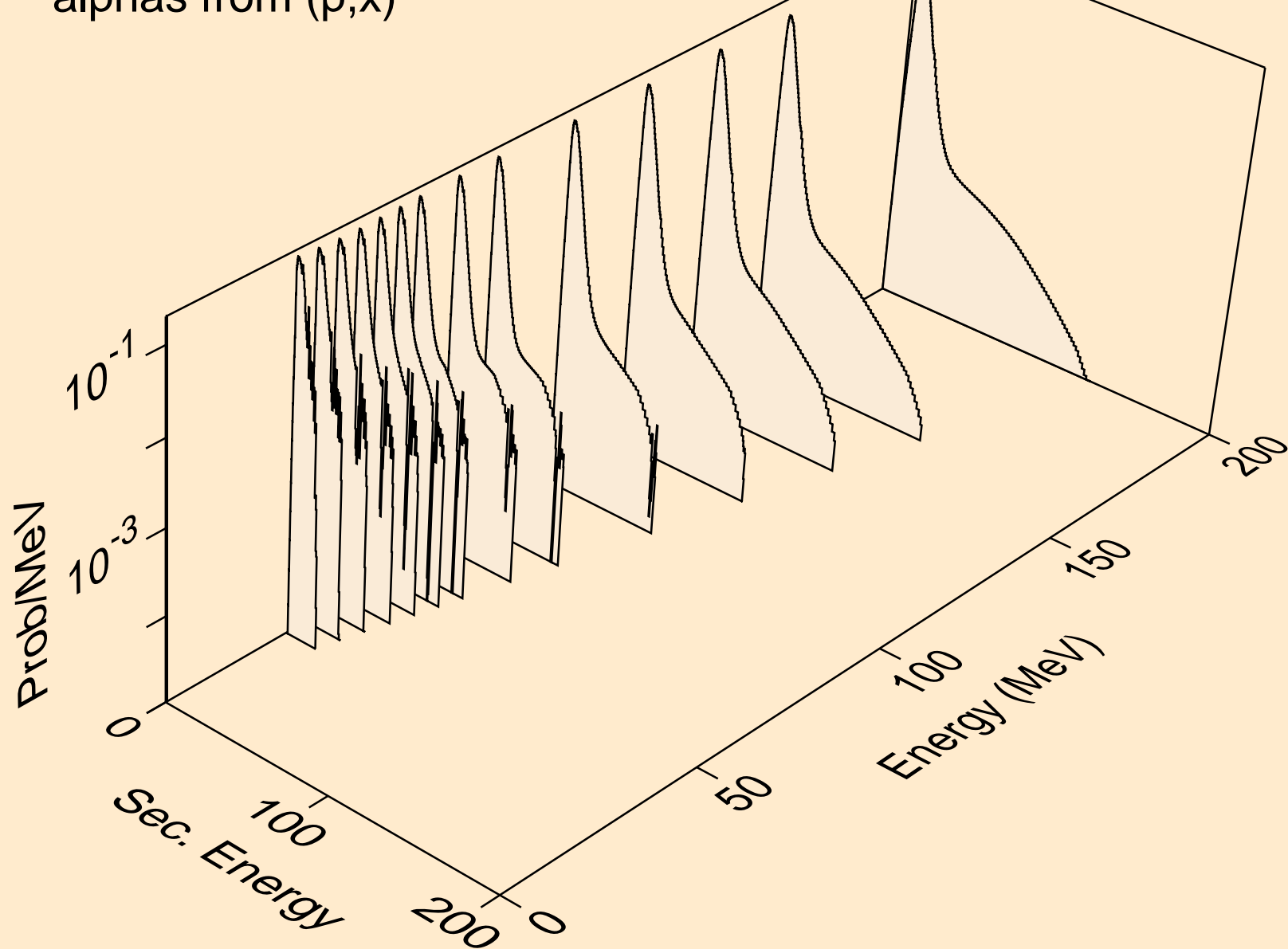

F017 PROTON ACER TENDL-2024 LIBRARY; T=0.K
alphas from (p,n*)a

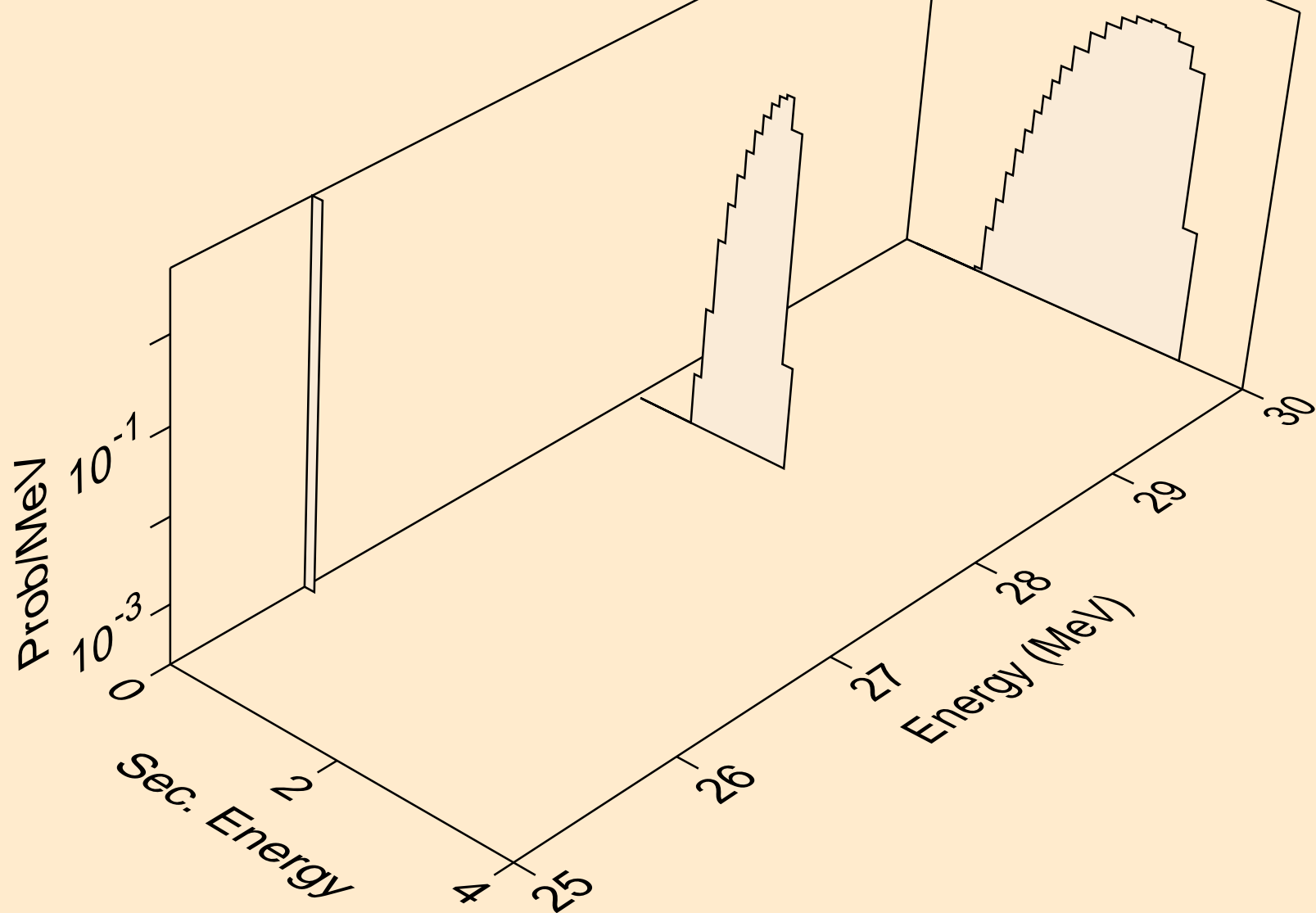

F017 PROTON ACER TENDL-2024 LIBRARY; T=0.K
alphas from (p,a)

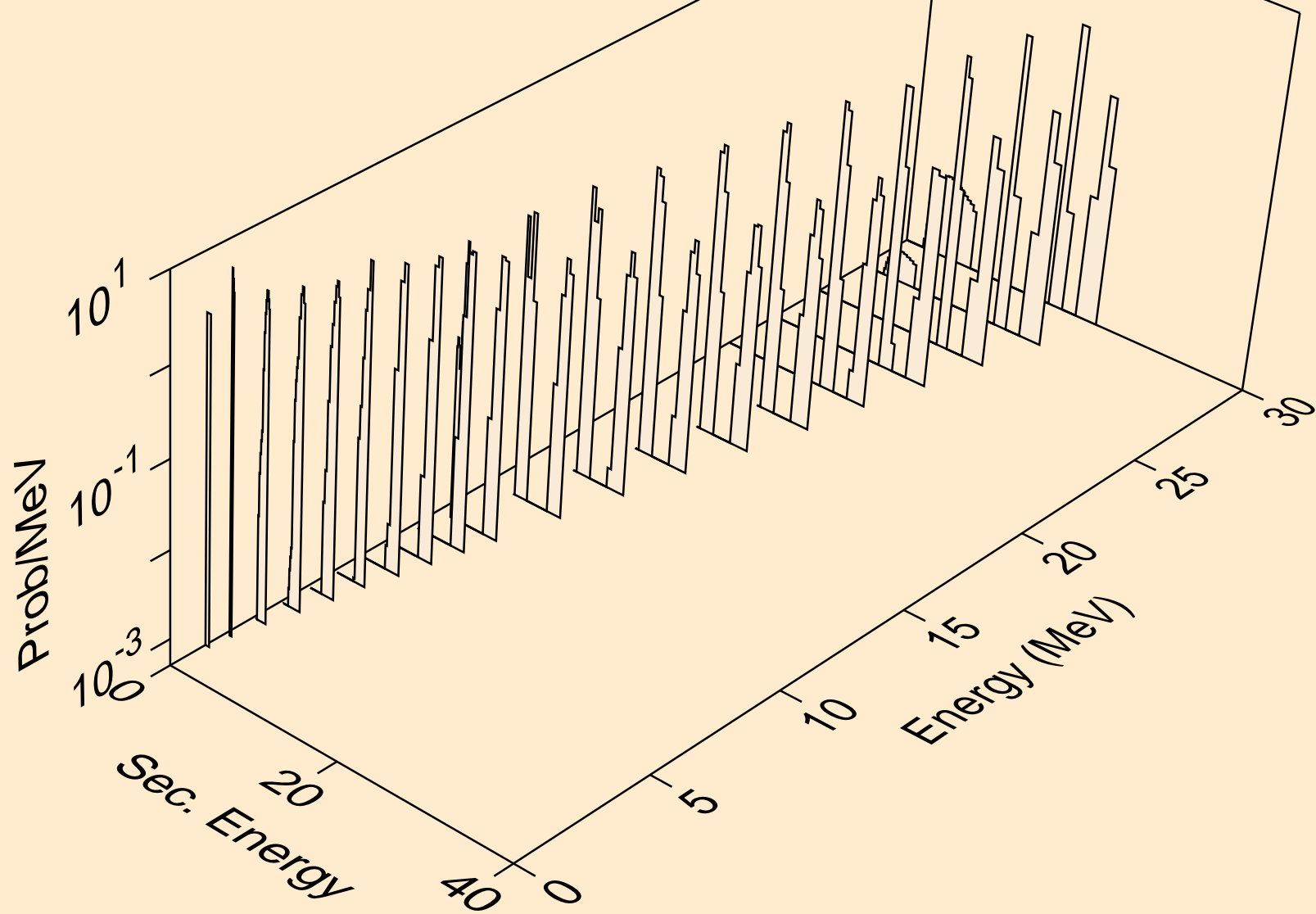

F017 PROTON ACER TENDL-2024 LIBRARY; T=0.K
alphas from (p,2a)

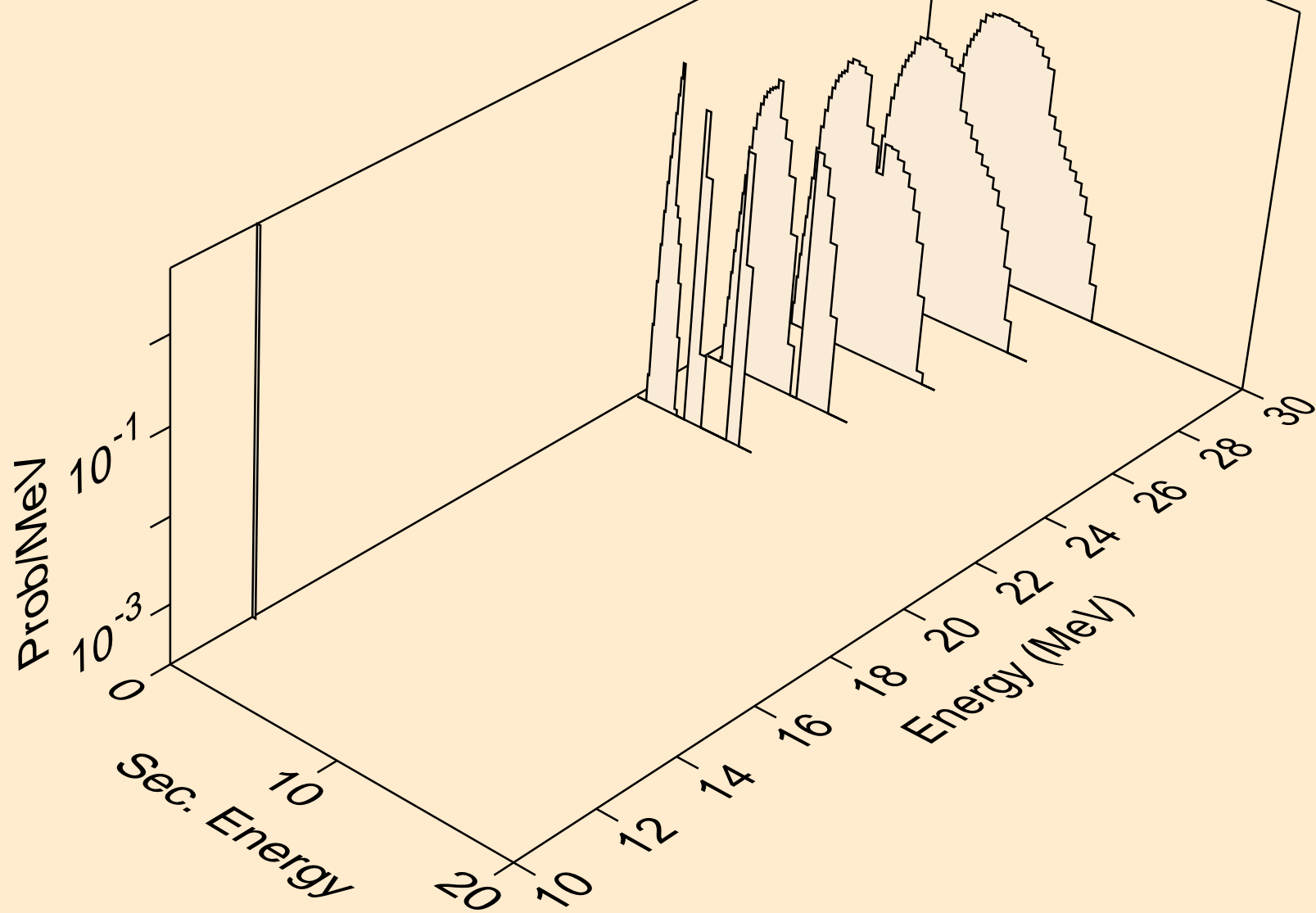

F017 PROTON ACER TENDL-2024 LIBRARY; T=0.K
alphas from (p,pa)

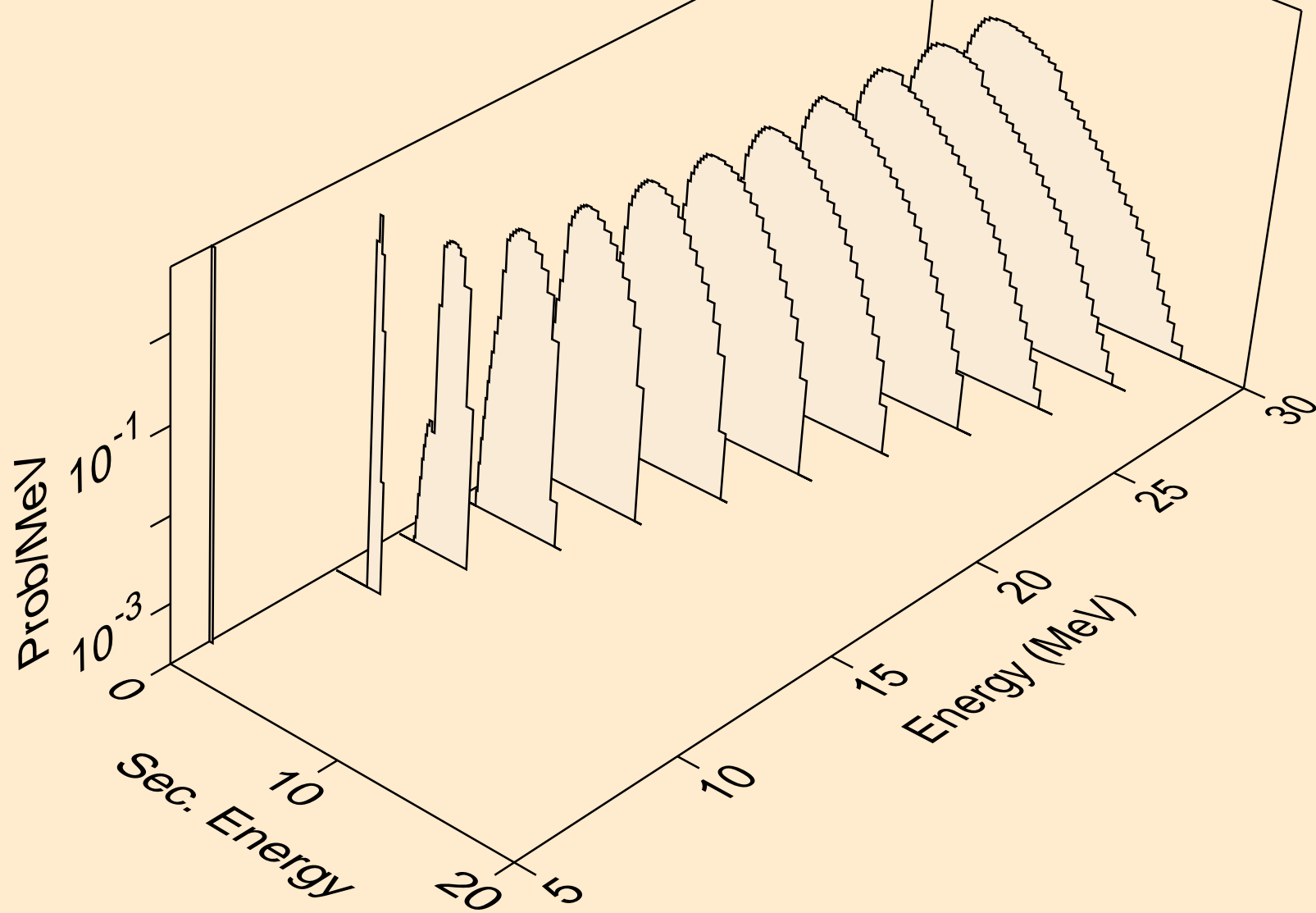

F017 PROTON ACER TENDL-2024 LIBRARY; T=0.K
alphas from (p,da)

