

# P029 PROTON ACER TENDL-2024 LIBRARY; T=0.K

## Principal cross sections

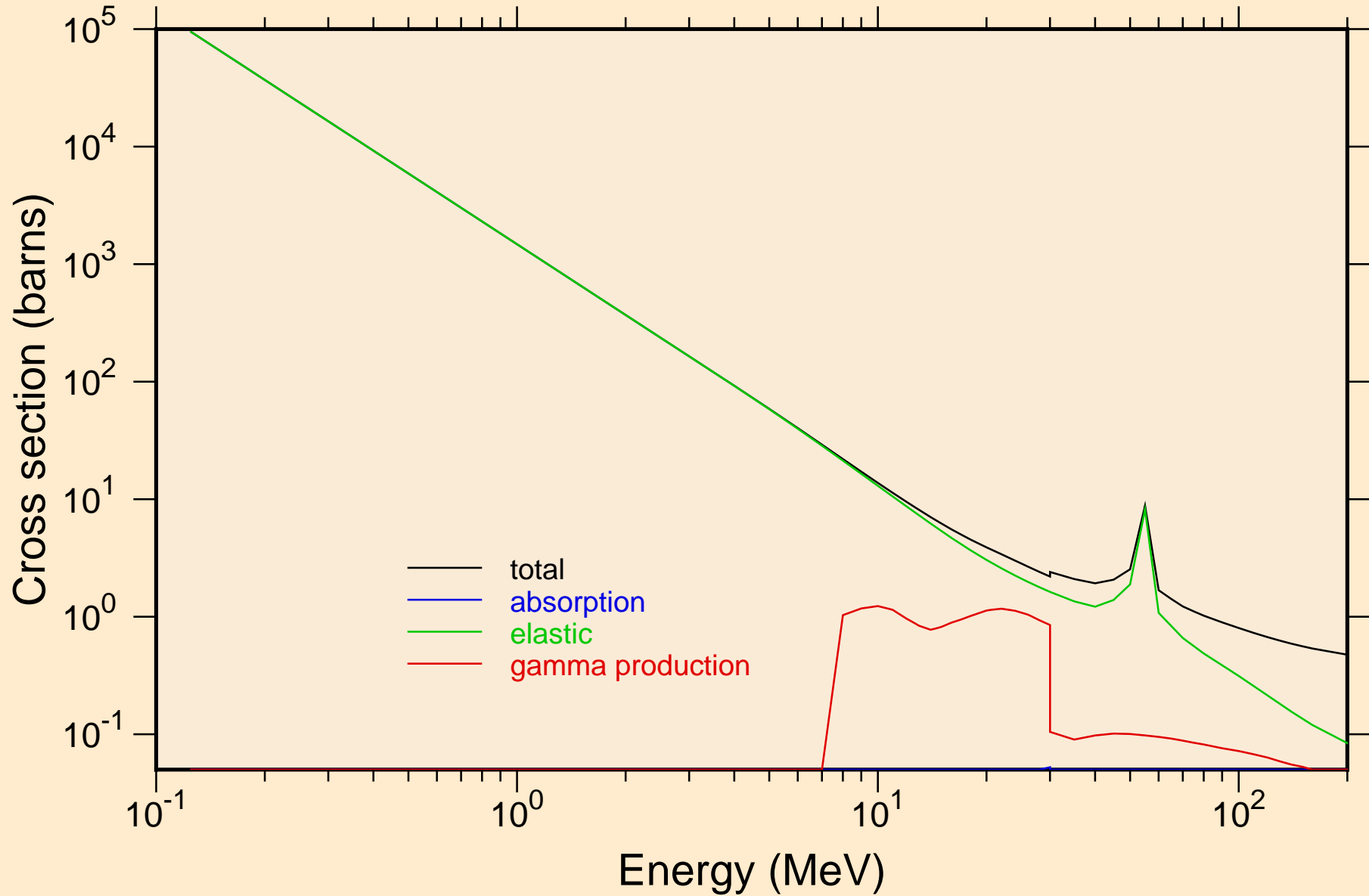

P029 PROTON ACER TENDL-2024 LIBRARY; T=0.K  
Heating

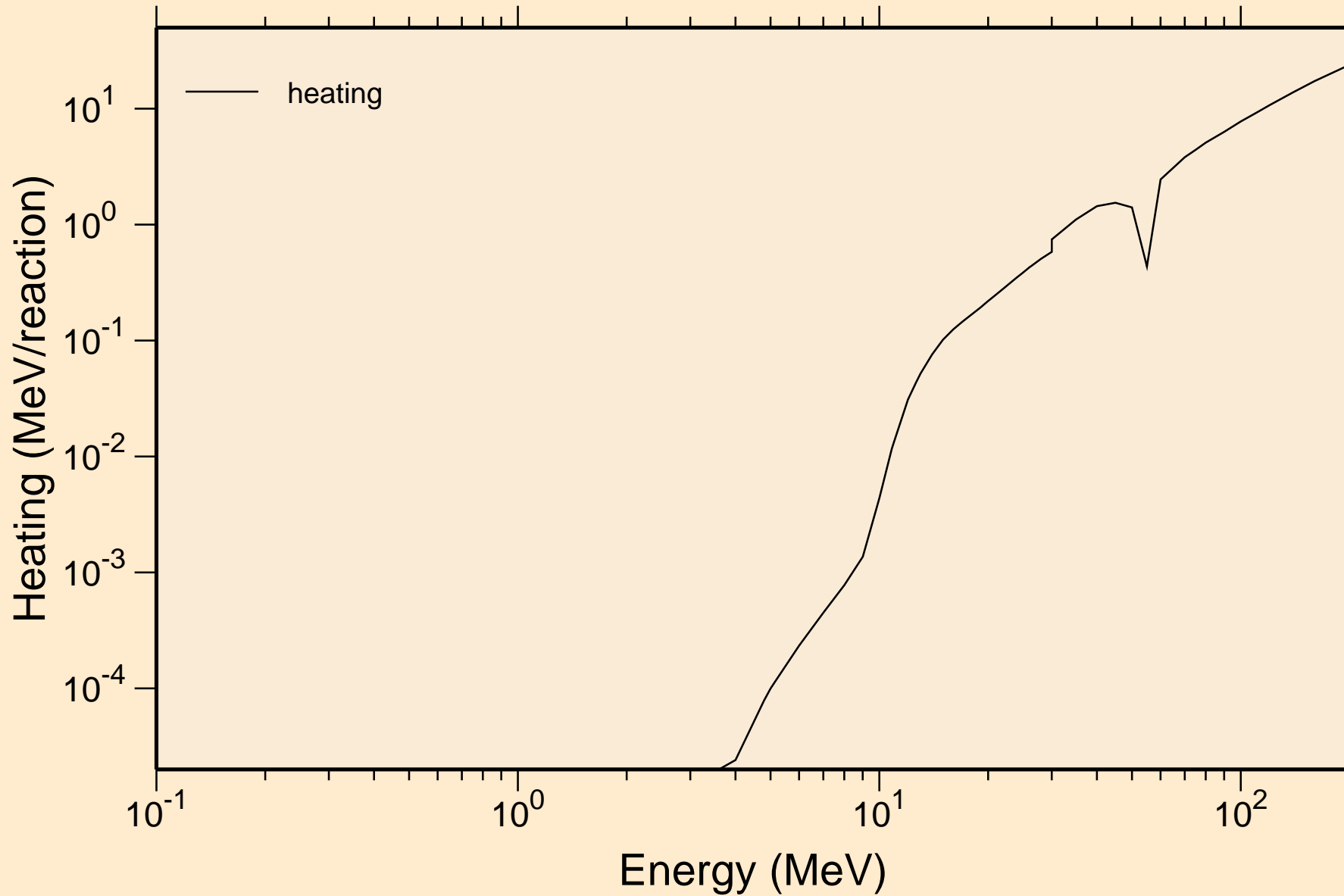

# P029 PROTON ACER TENDL-2024 LIBRARY; T=0.K

## Principal cross sections

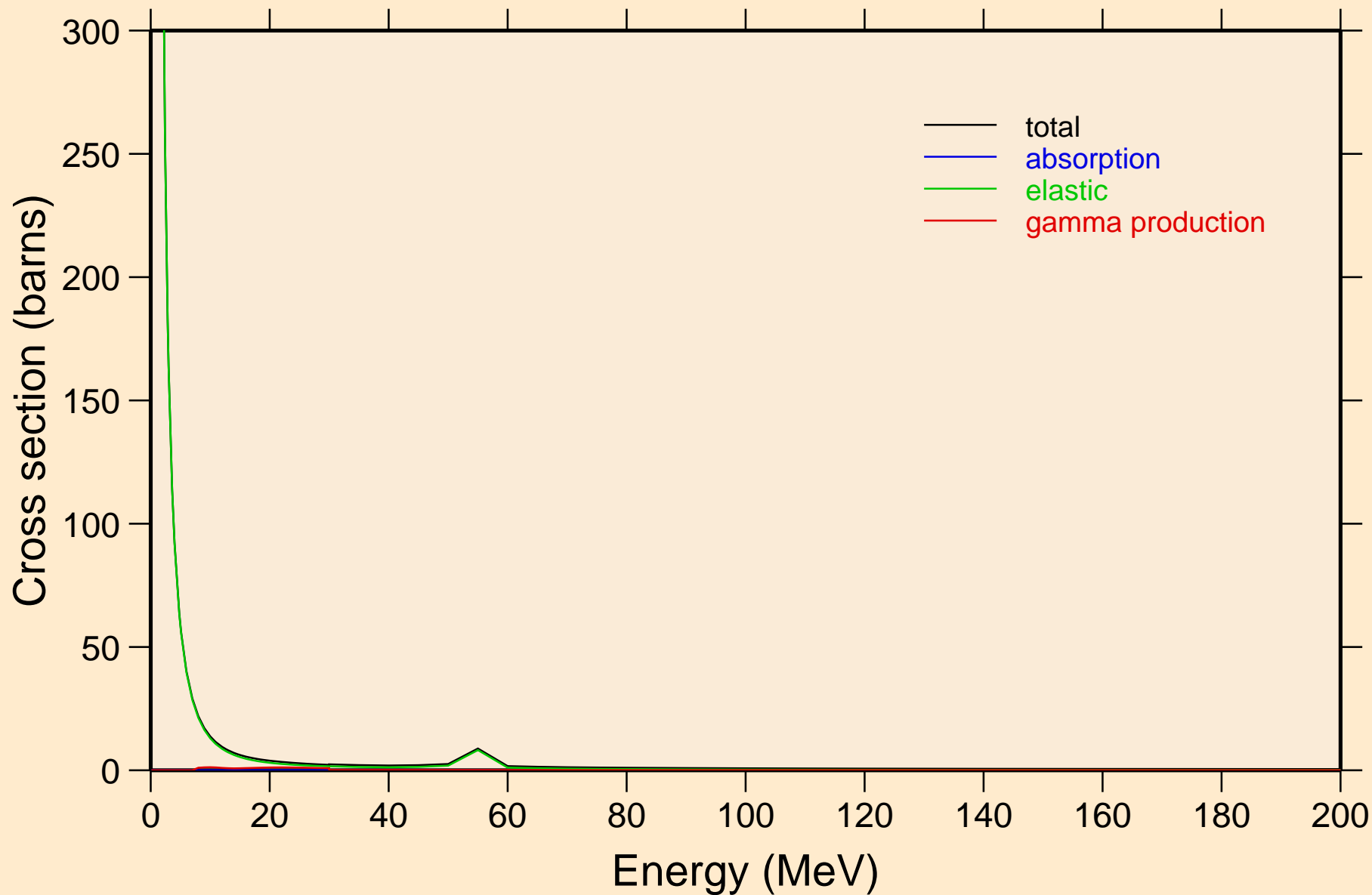

# P029 PROTON ACER TENDL-2024 LIBRARY; T=0.K

## Heating

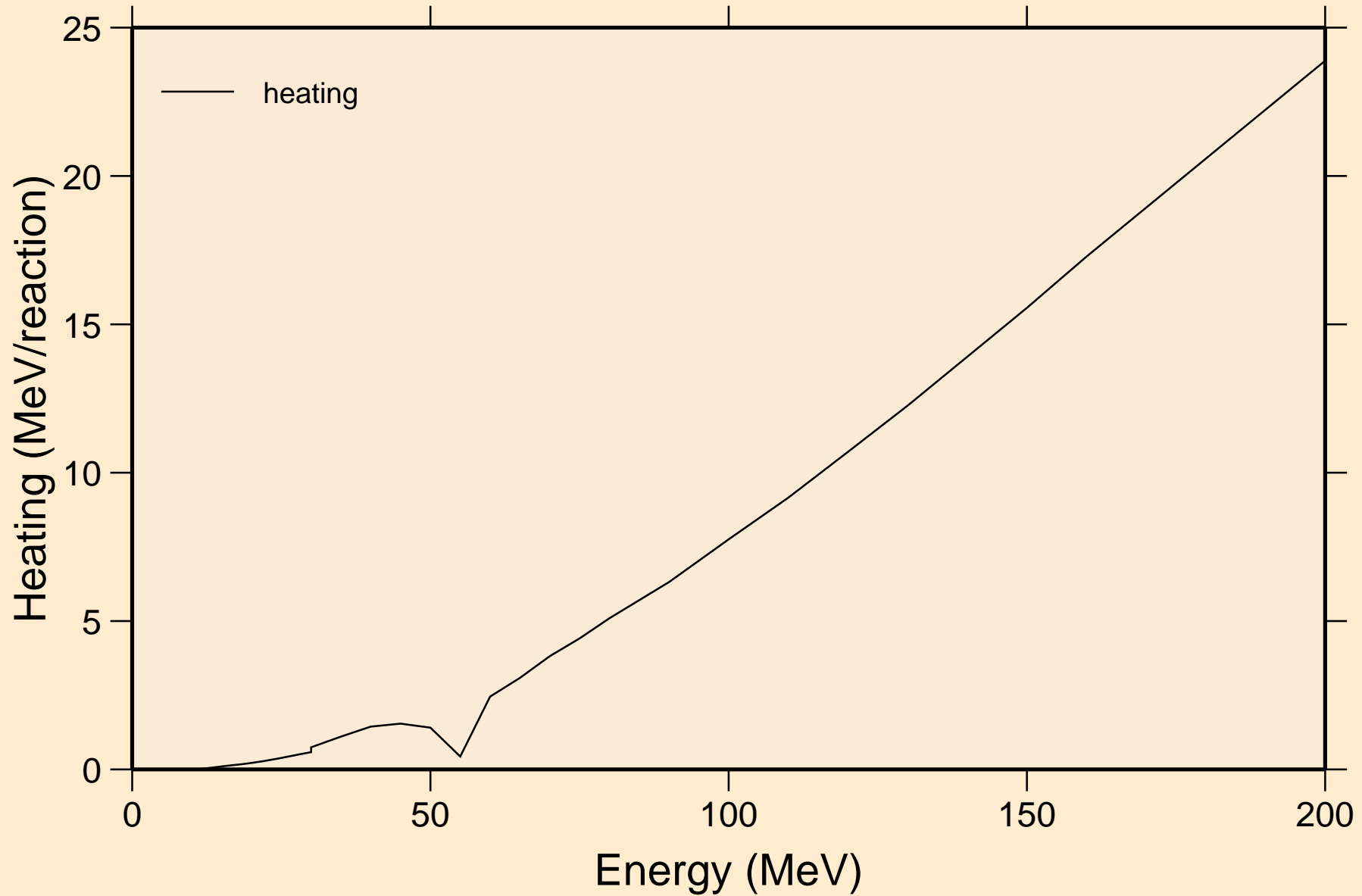

# P029 PROTON ACER TENDL-2024 LIBRARY; T=0.K

## Threshold reactions

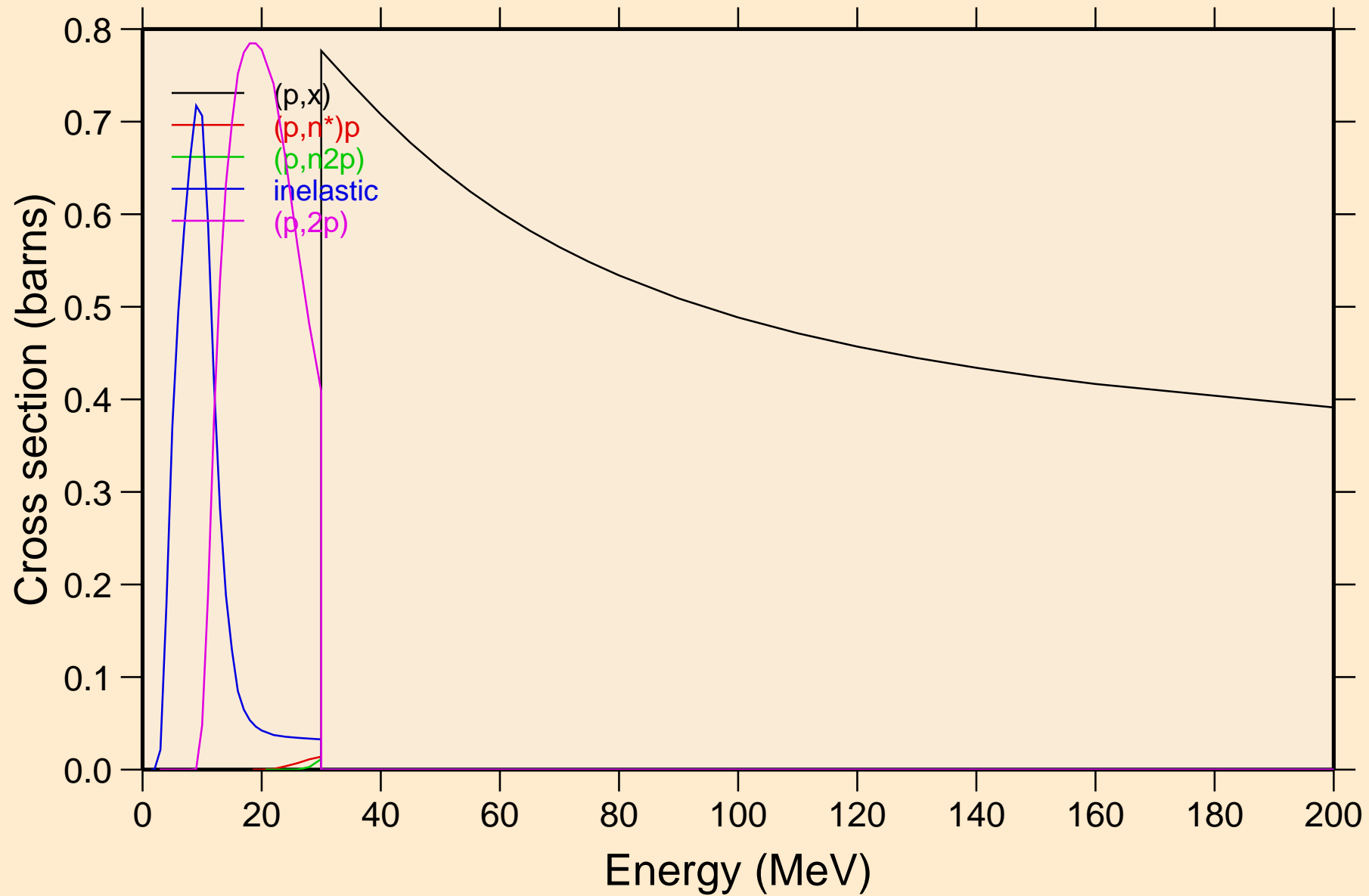

P029 PROTON ACER TENDL-2024 LIBRARY; T=0.K  
Threshold reactions

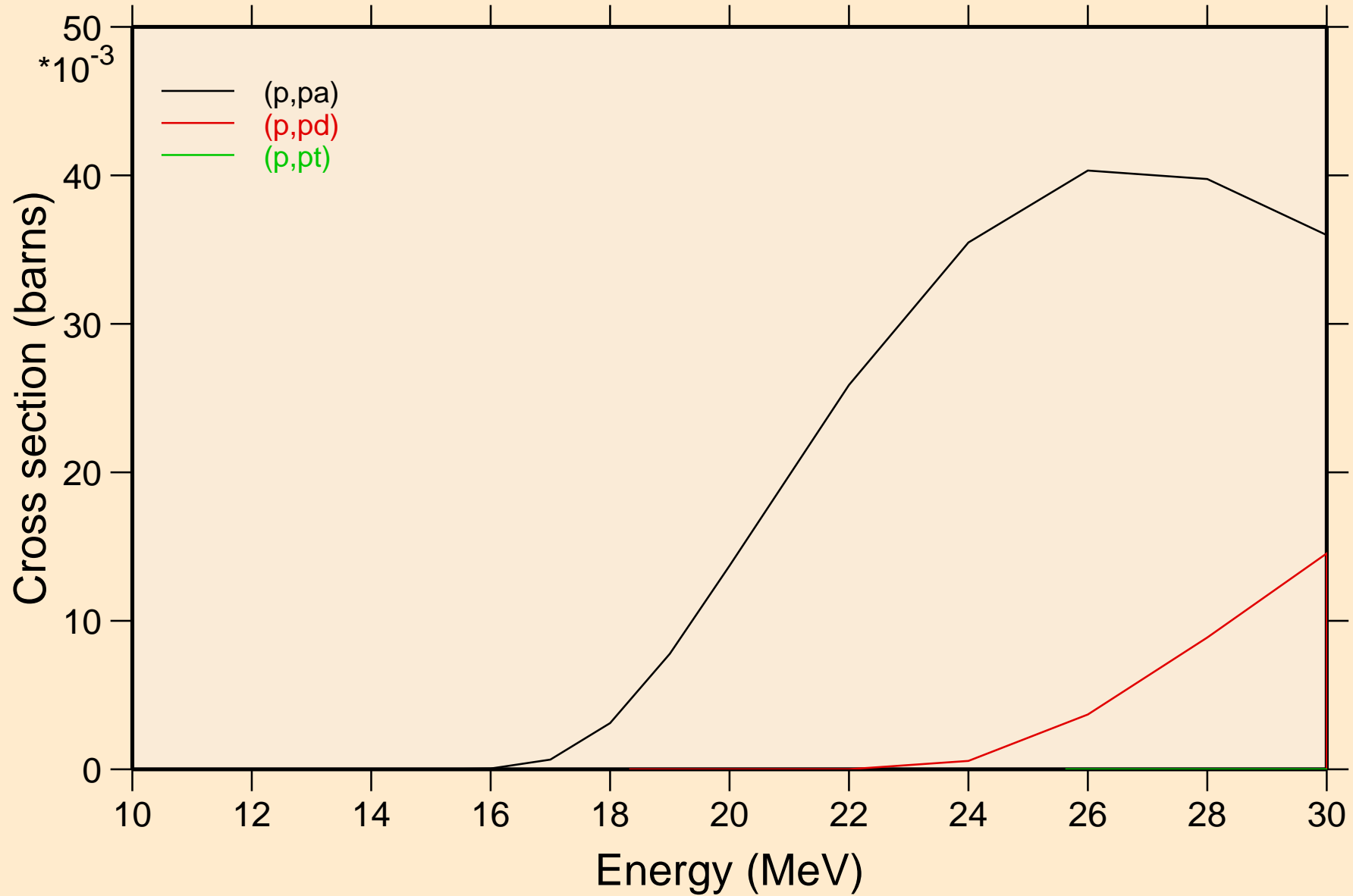

P029 PROTON ACER TENDL-2024 LIBRARY; T=0.K  
angular distribution for elastic

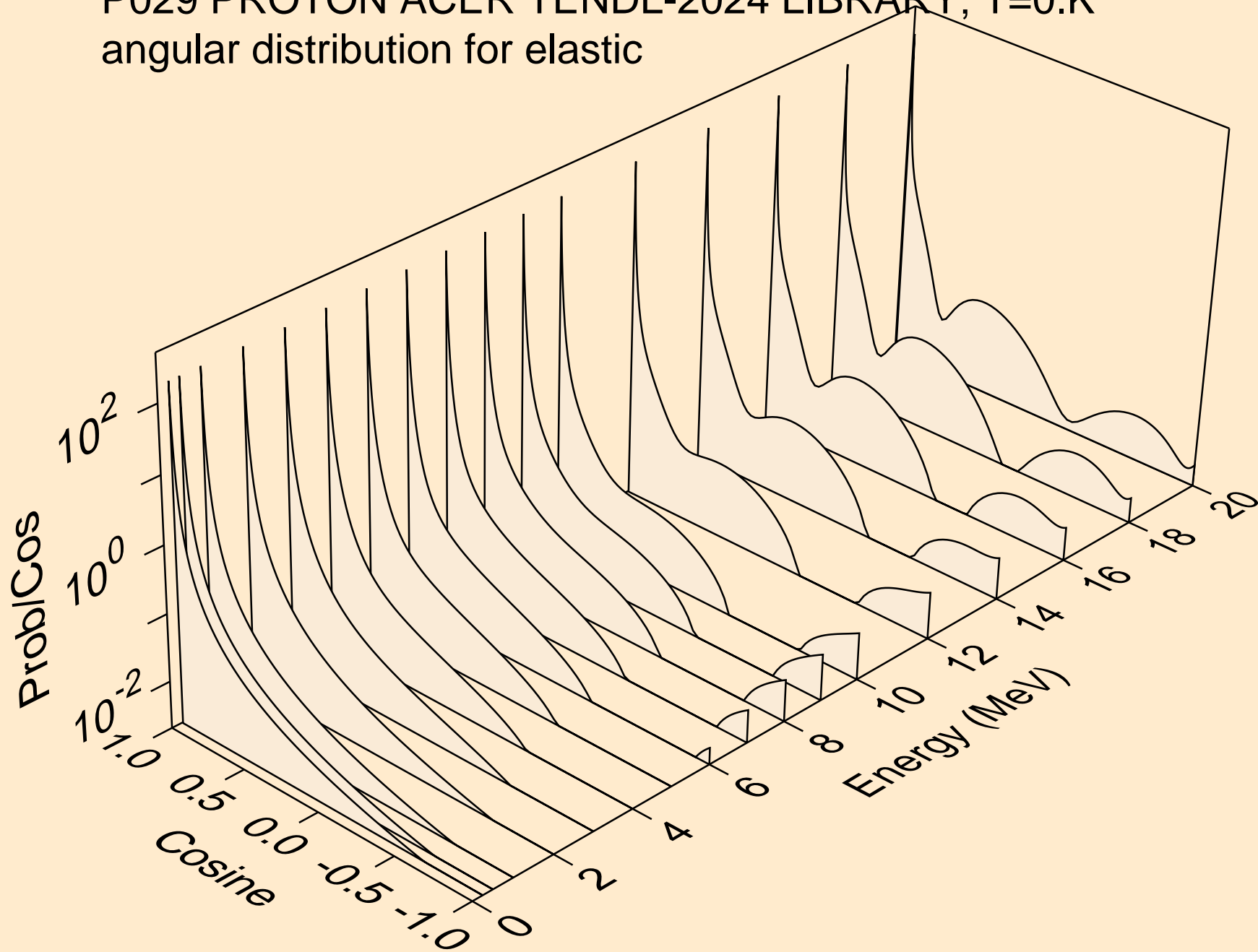

P029 PROTON ACER TENDL-2024 LIBRARY; T=0.K  
angular distribution for elastic

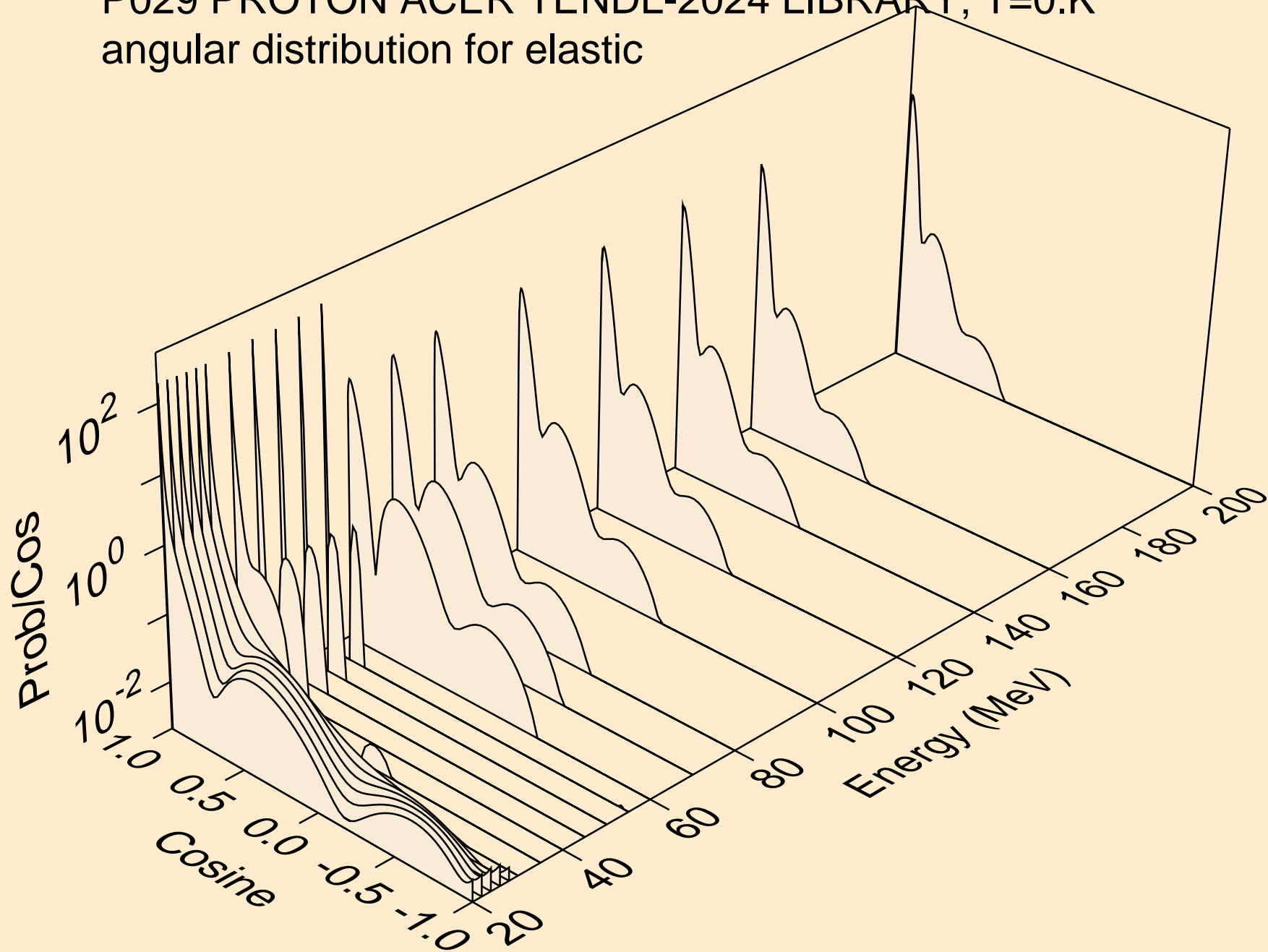

P029 PROTON ACER TENDL-2024 LIBRARY; T=0.K  
Proton emission for (p,x)

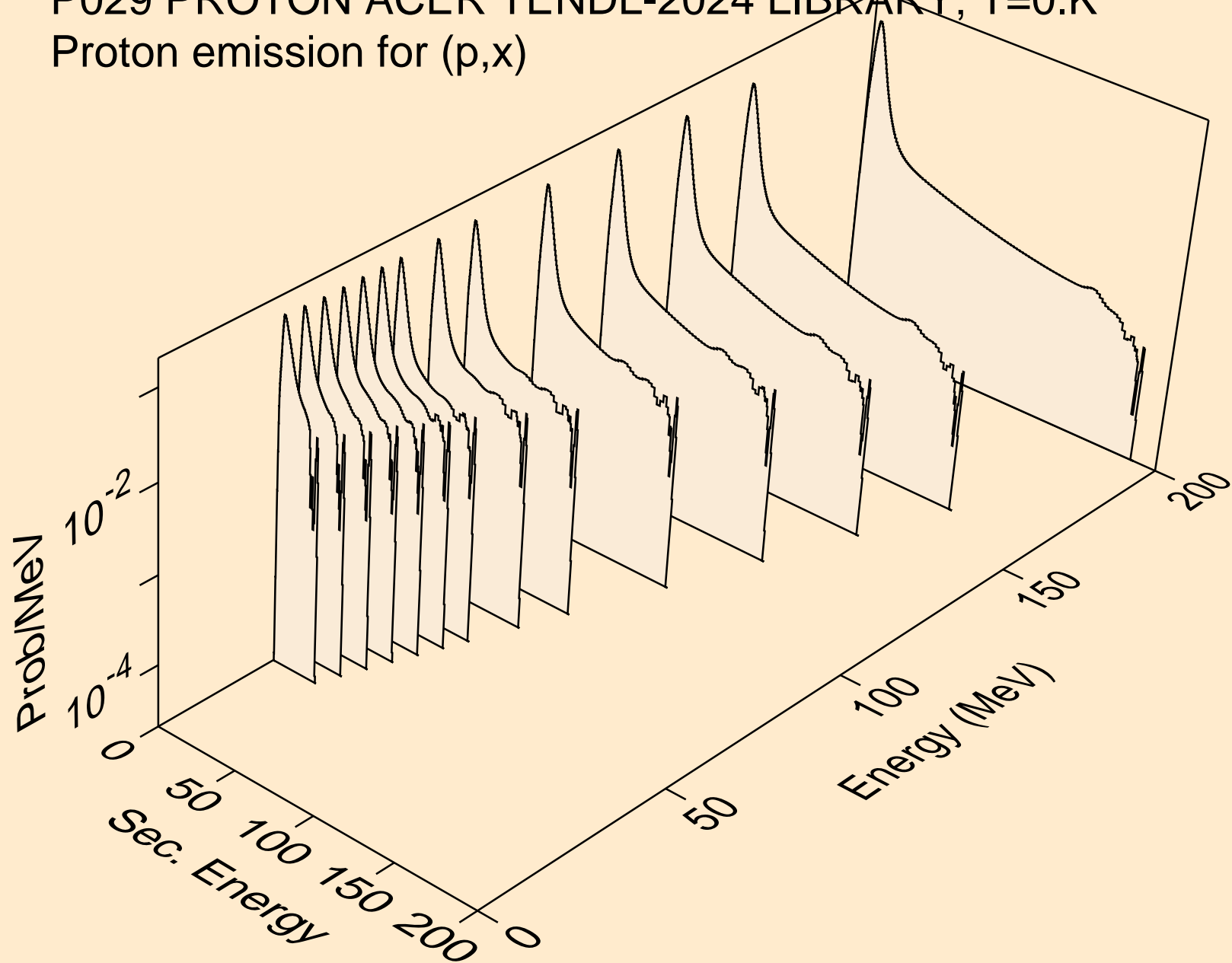

P029 PROTON ACER TENDL-2024 LIBRARY; T=0.K  
Proton emission for (p,n\*)p

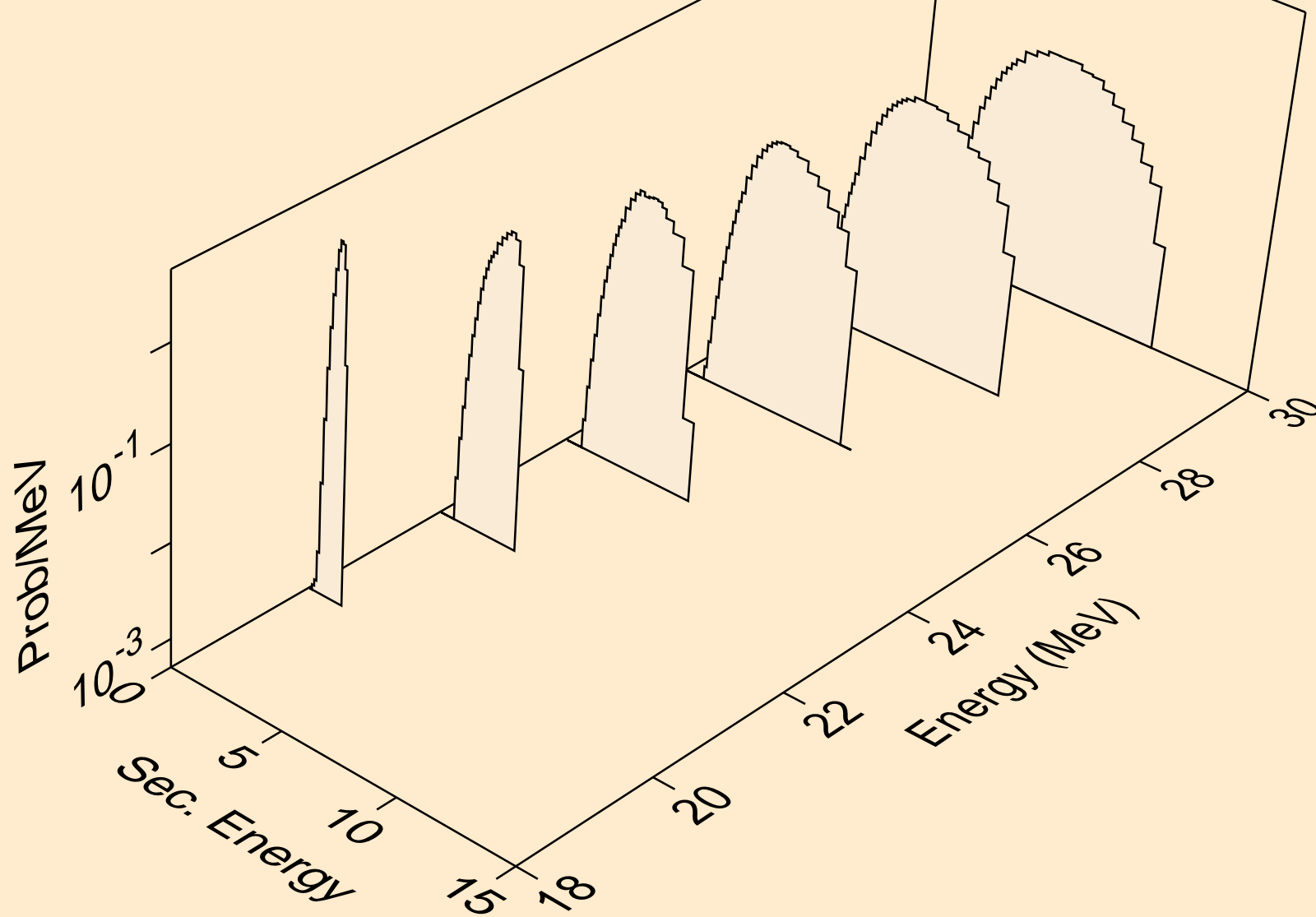

P029 PROTON ACER TENDL-2024 LIBRARY; T=0.K  
Proton emission for (p,n2p)

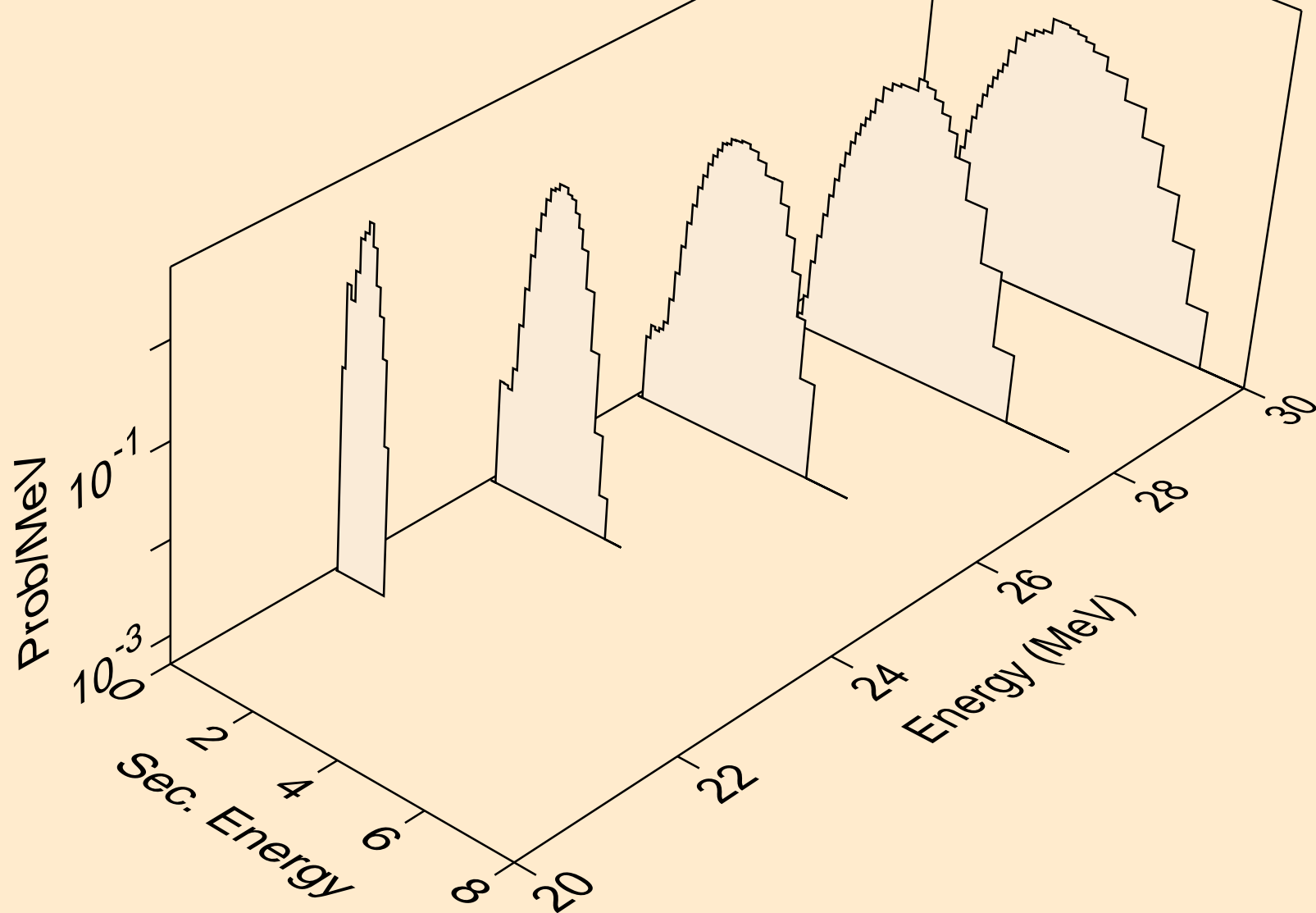

P029 PROTON ACER TENDL-2024 LIBRARY; T=0.K  
Proton emission for inelastic

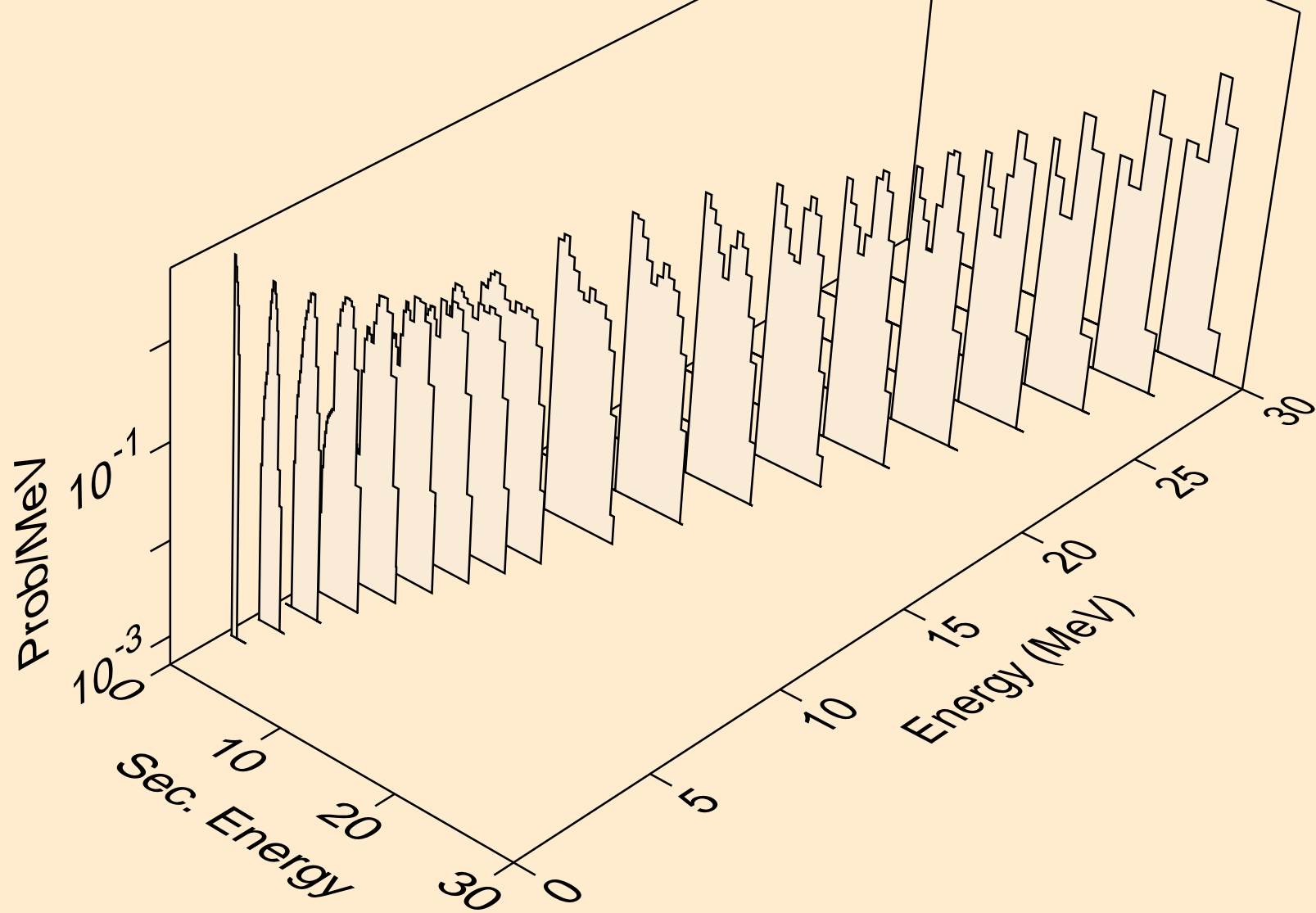

P029 PROTON ACER TENDL-2024 LIBRARY; T=0.K  
Proton emission for (p,2p)

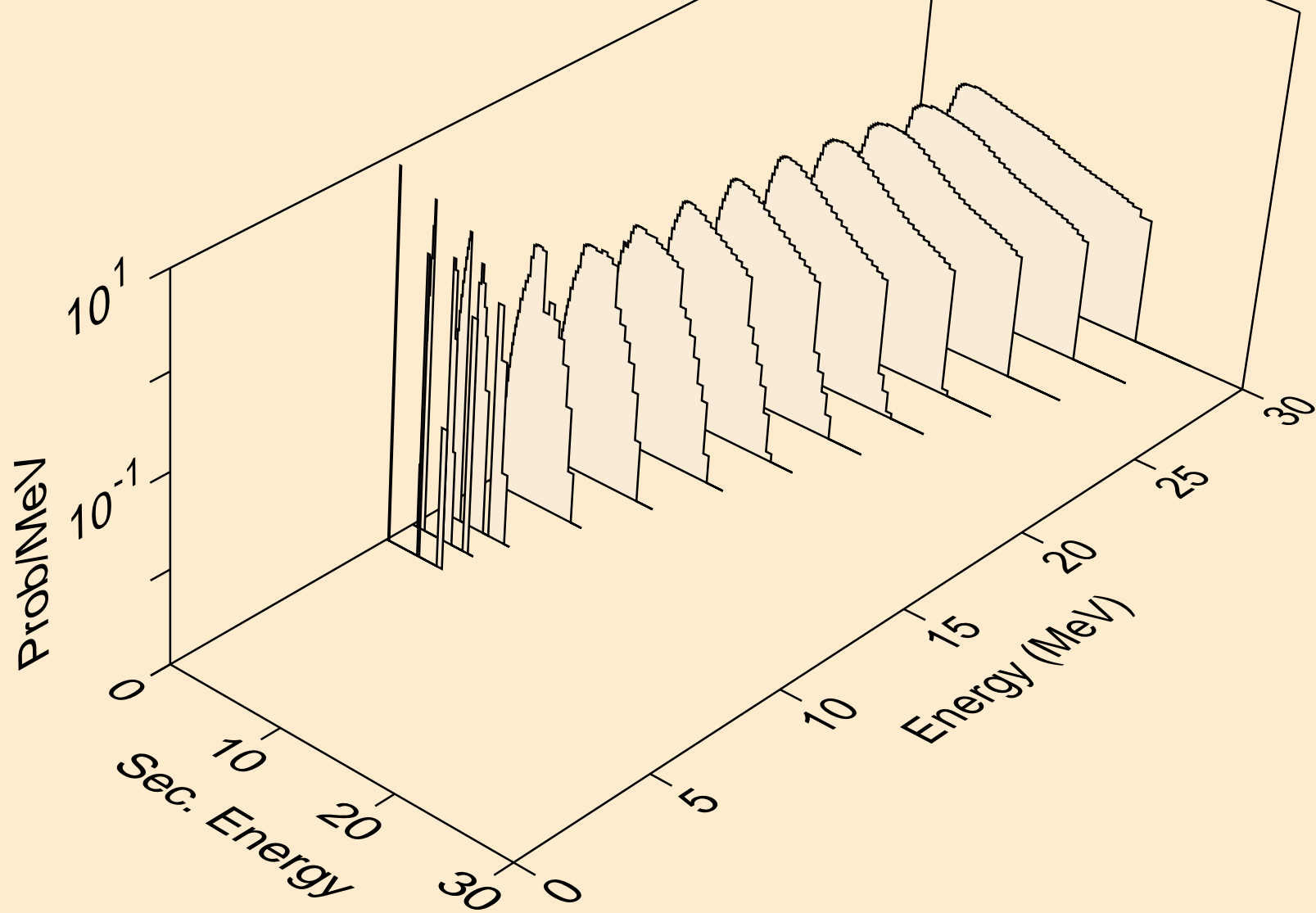

P029 PROTON ACER TENDL-2024 LIBRARY; T=0.K  
Proton emission for (p,pa)

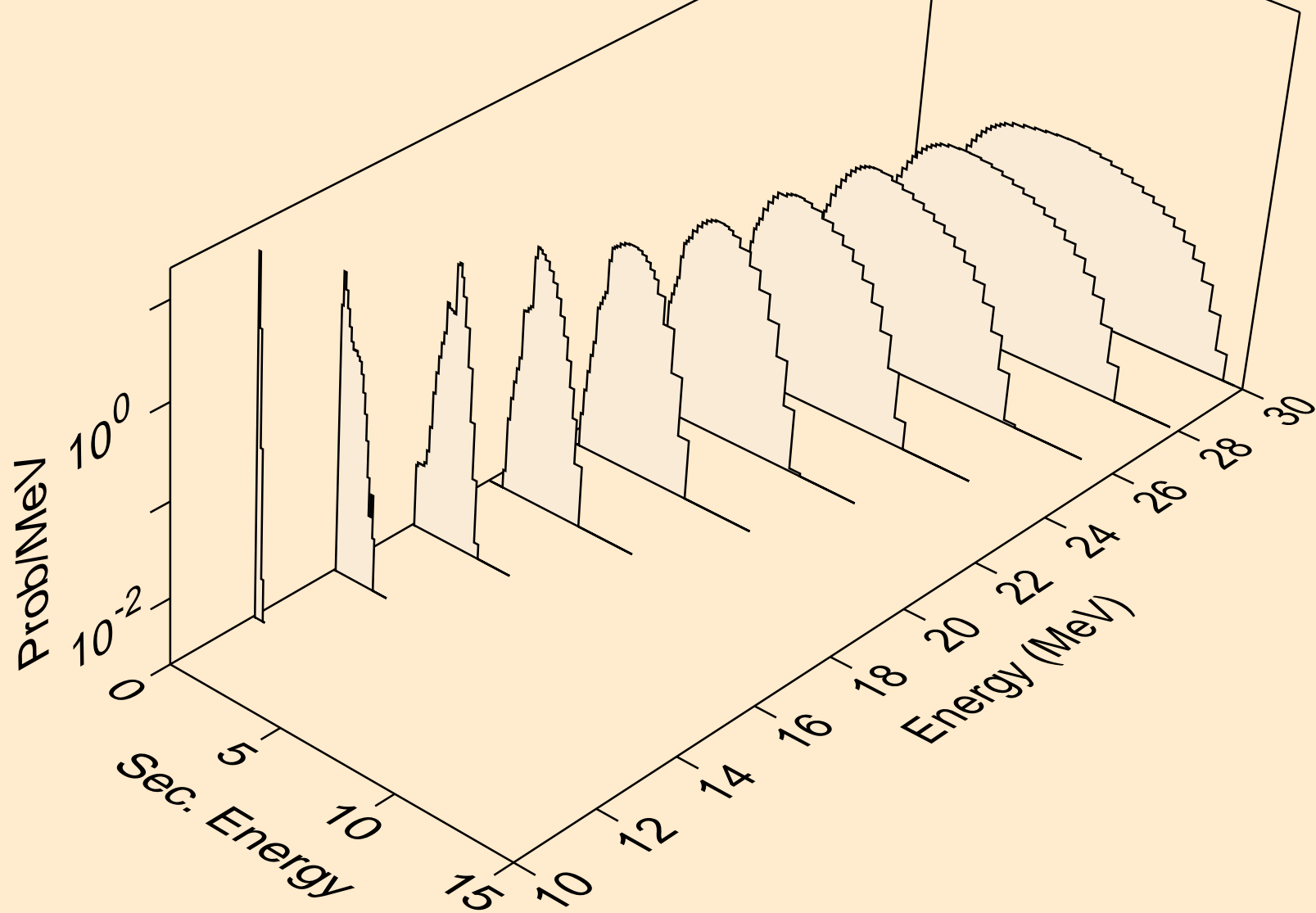

P029 PROTON ACER TENDL-2024 LIBRARY; T=0.K  
Proton emission for (p,pd)

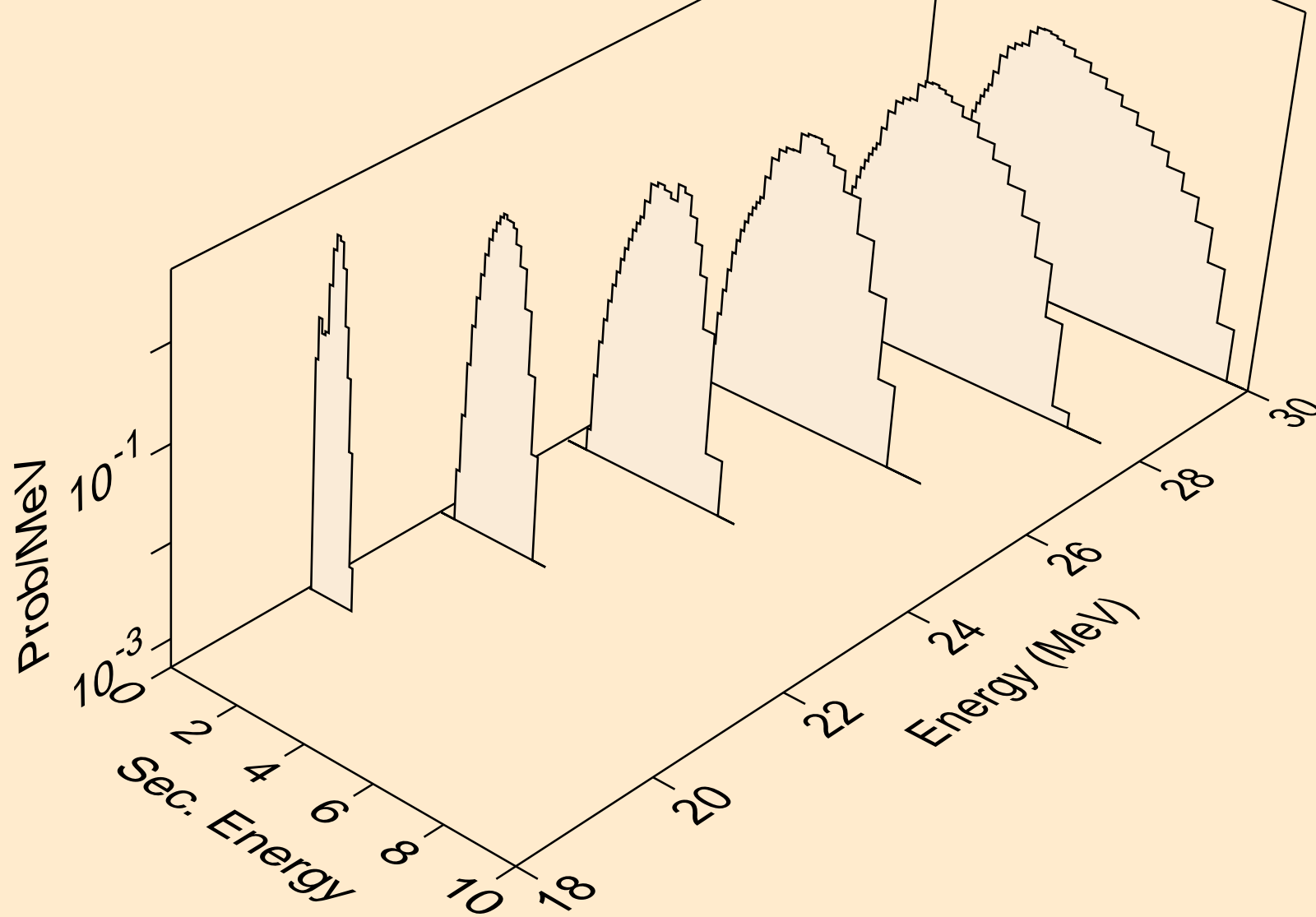

P029 PROTON ACER TENDL-2024 LIBRARY; T=0.K  
Proton emission for (p,pt)

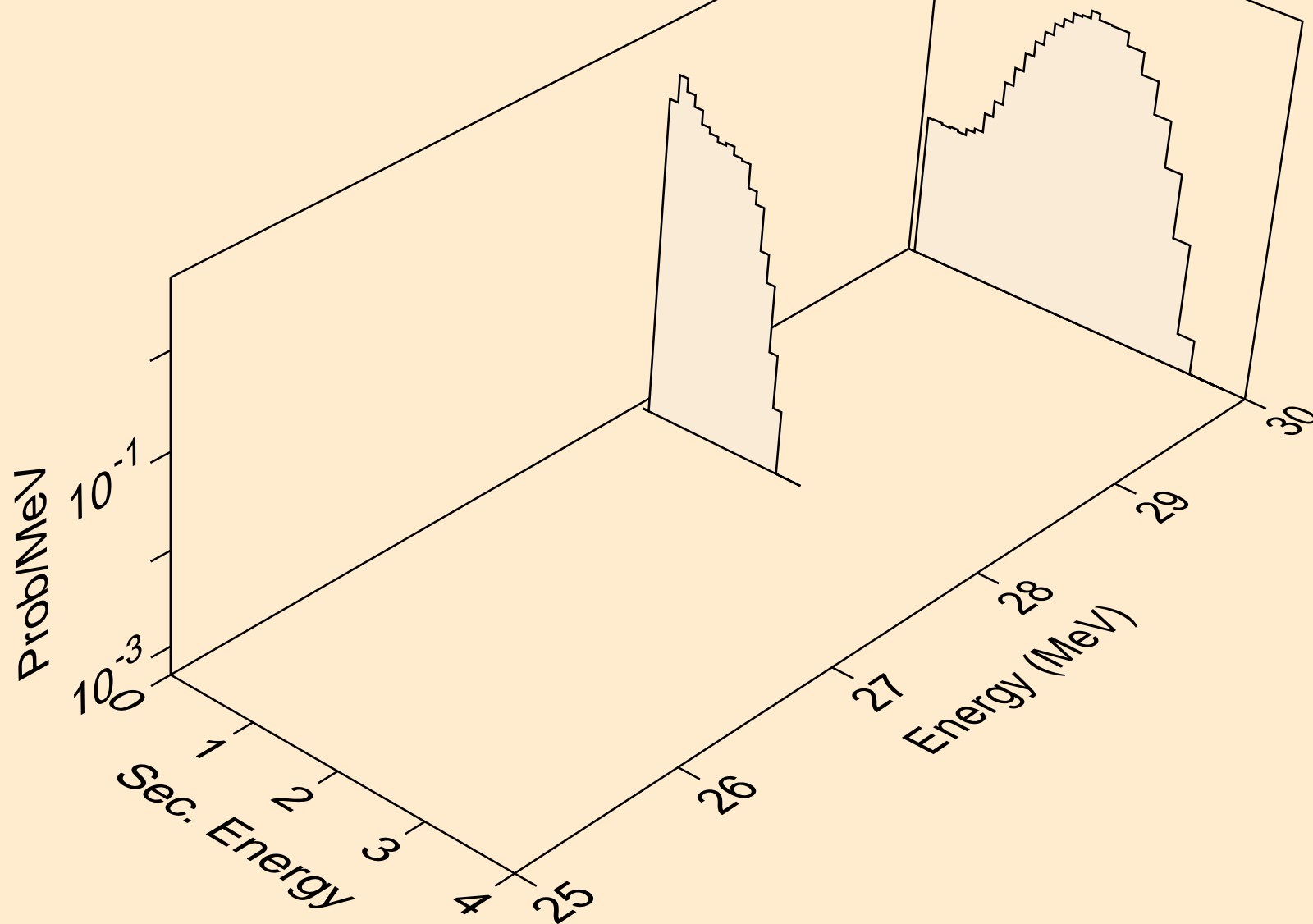

P029 PROTON ACER TENDL-2024 LIBRARY; T=0.K  
Photon emission for (z,n)

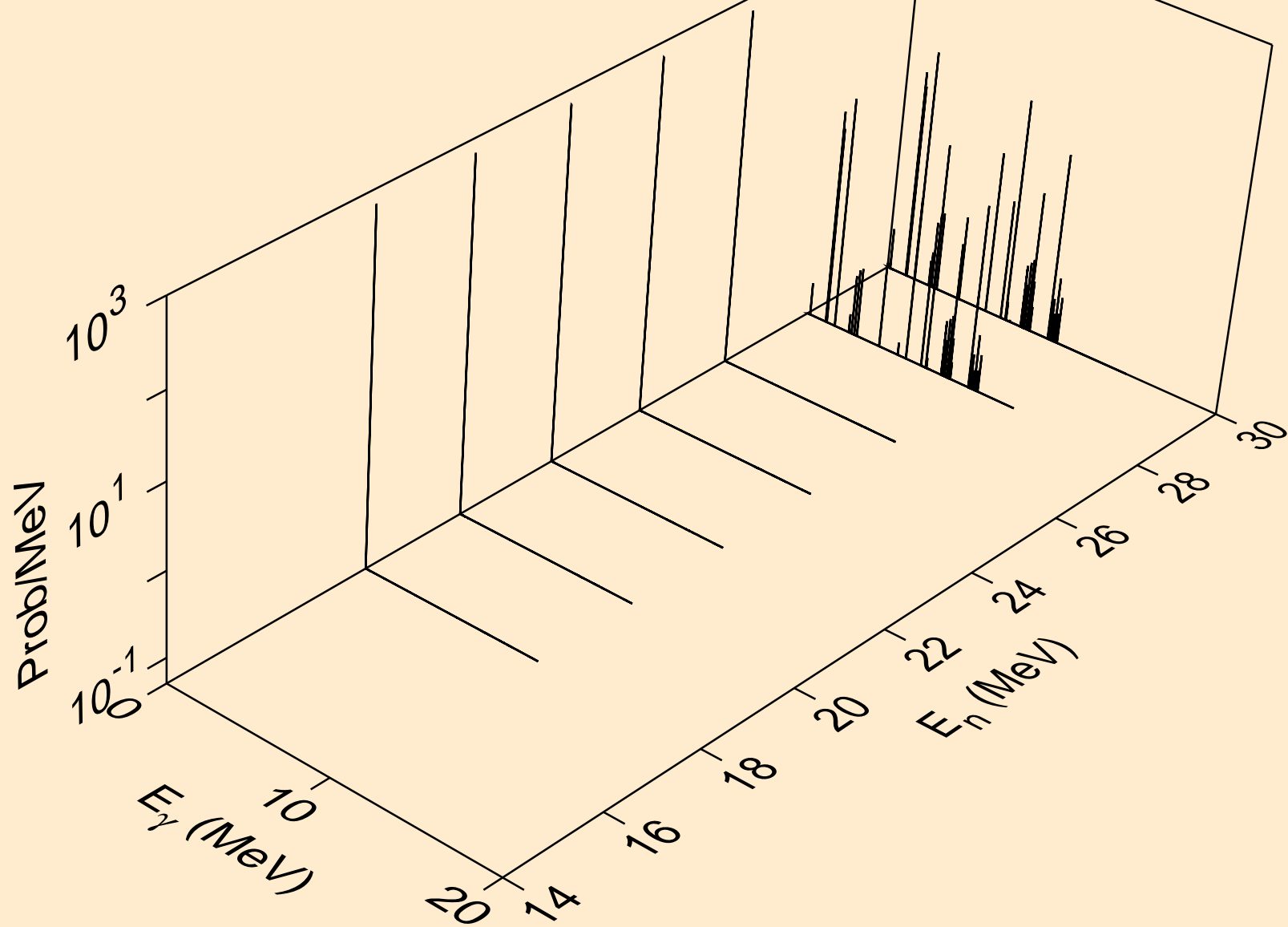

P029 PROTON ACER TENDL-2024 LIBRARY; T=0.K  
Photon emission for (z,x)

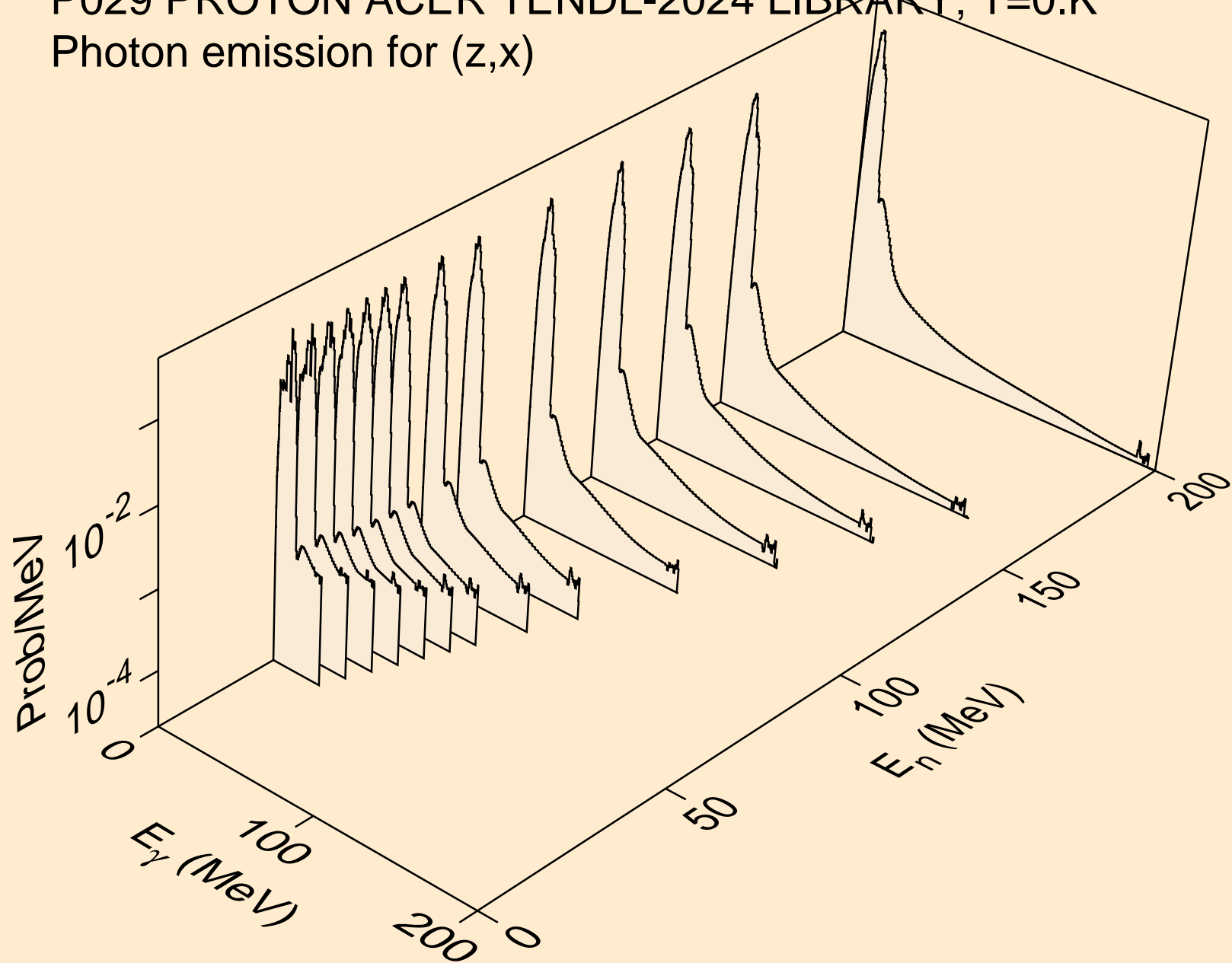

P029 PROTON ACER TENDL-2024 LIBRARY; T=0.K  
Photon emission for (n,n\*)a

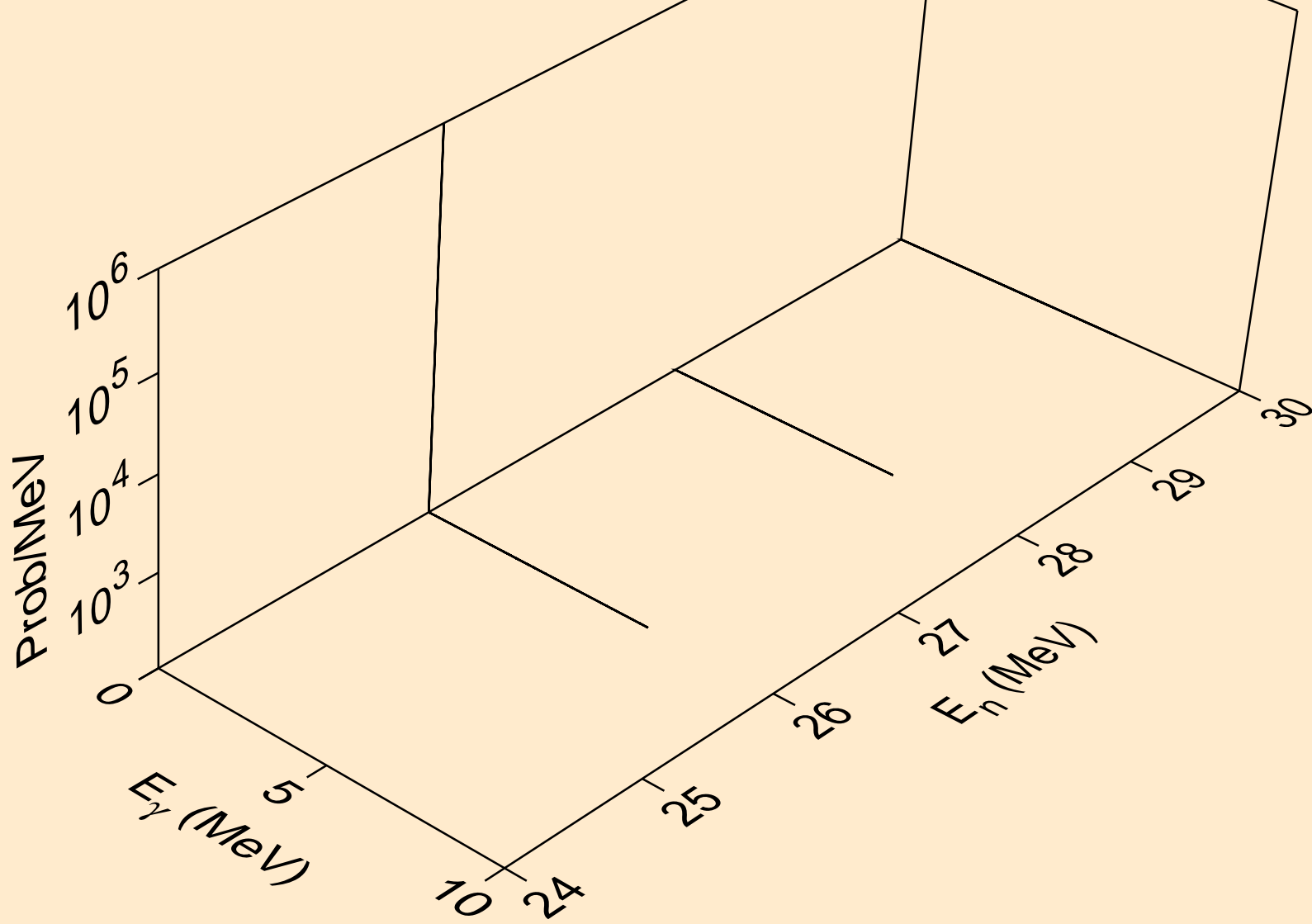

P029 PROTON ACER TENDL-2024 LIBRARY; T=0.K  
Photon emission for (n,n\*)p

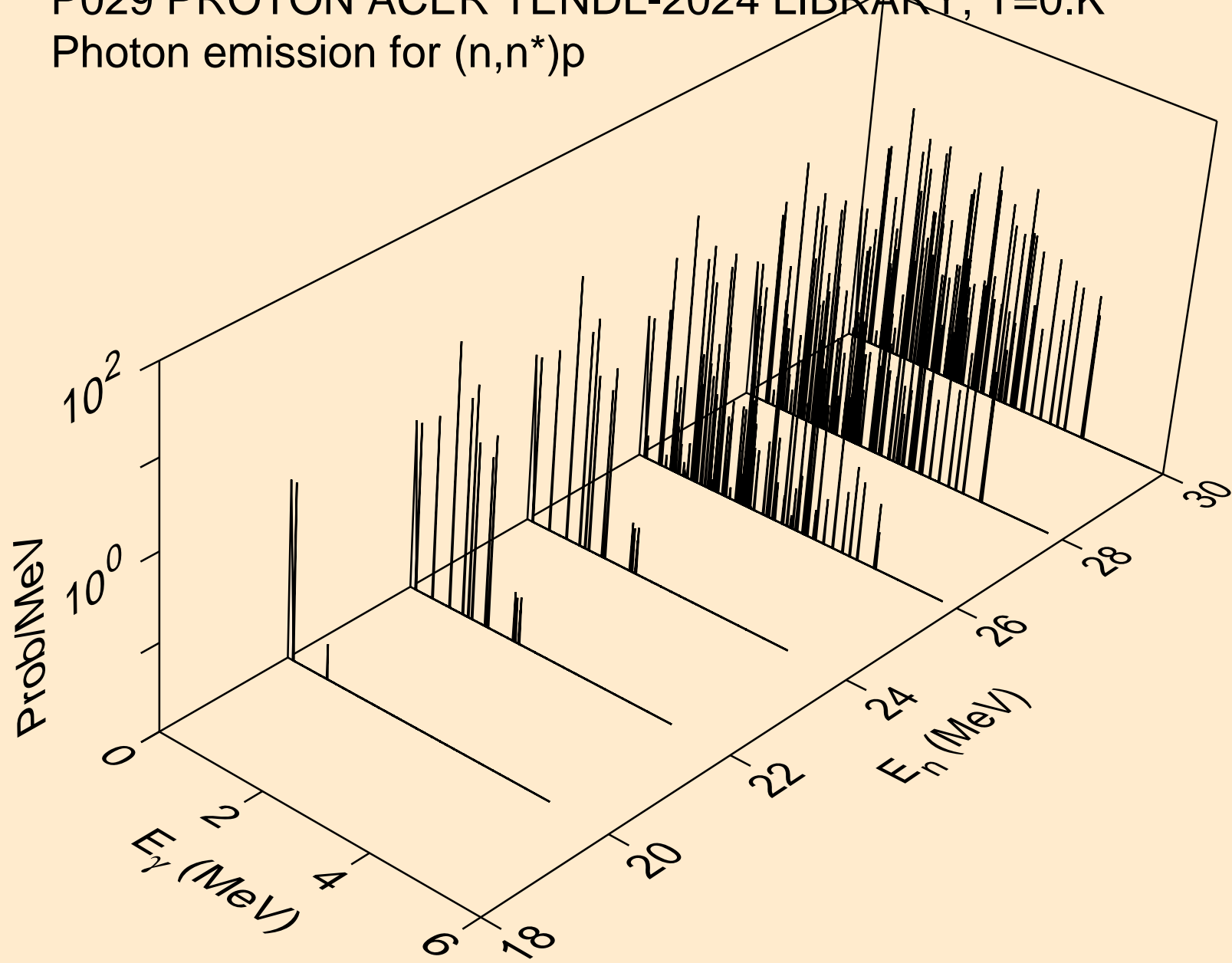

P029 PROTON ACER TENDL-2024 LIBRARY; T=0.K  
Photon emission for (n,n\*)he3

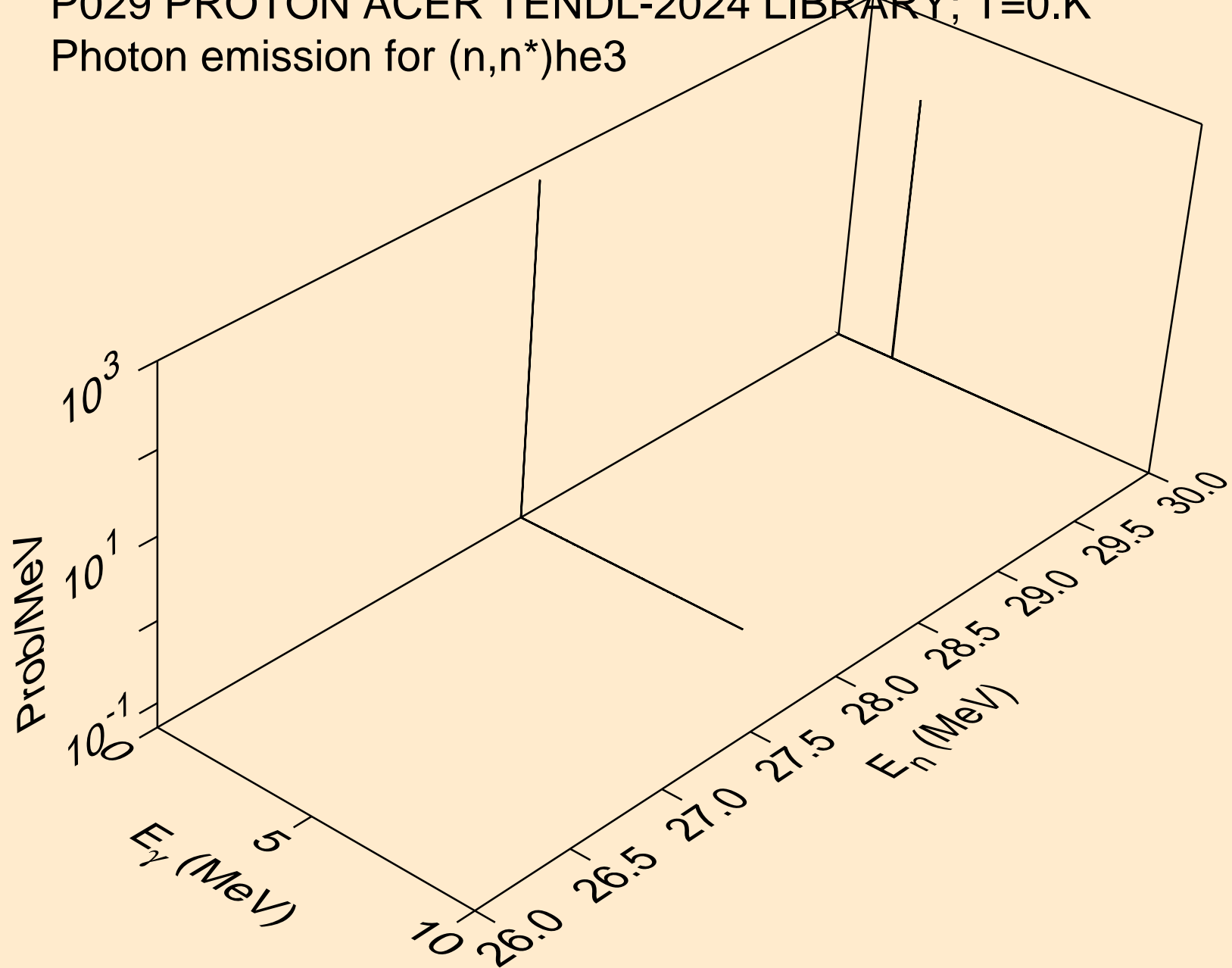

P029 PROTON ACER TENDL-2024 LIBRARY; T=0.K  
Photon emission for (n,n2p)

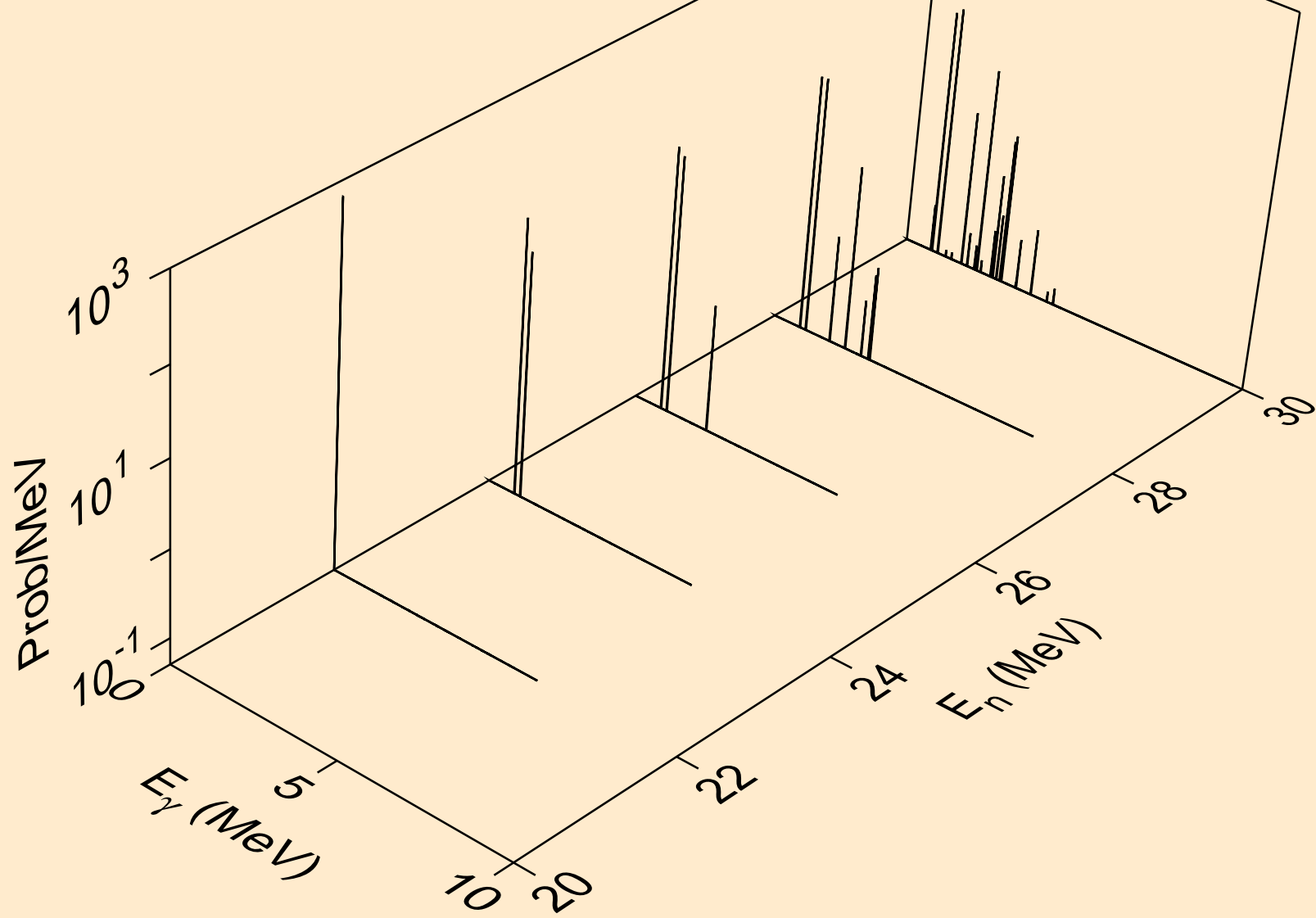

P029 PROTON ACER TENDL-2024 LIBRARY; T=0.K  
Photon emission for (n,gma)

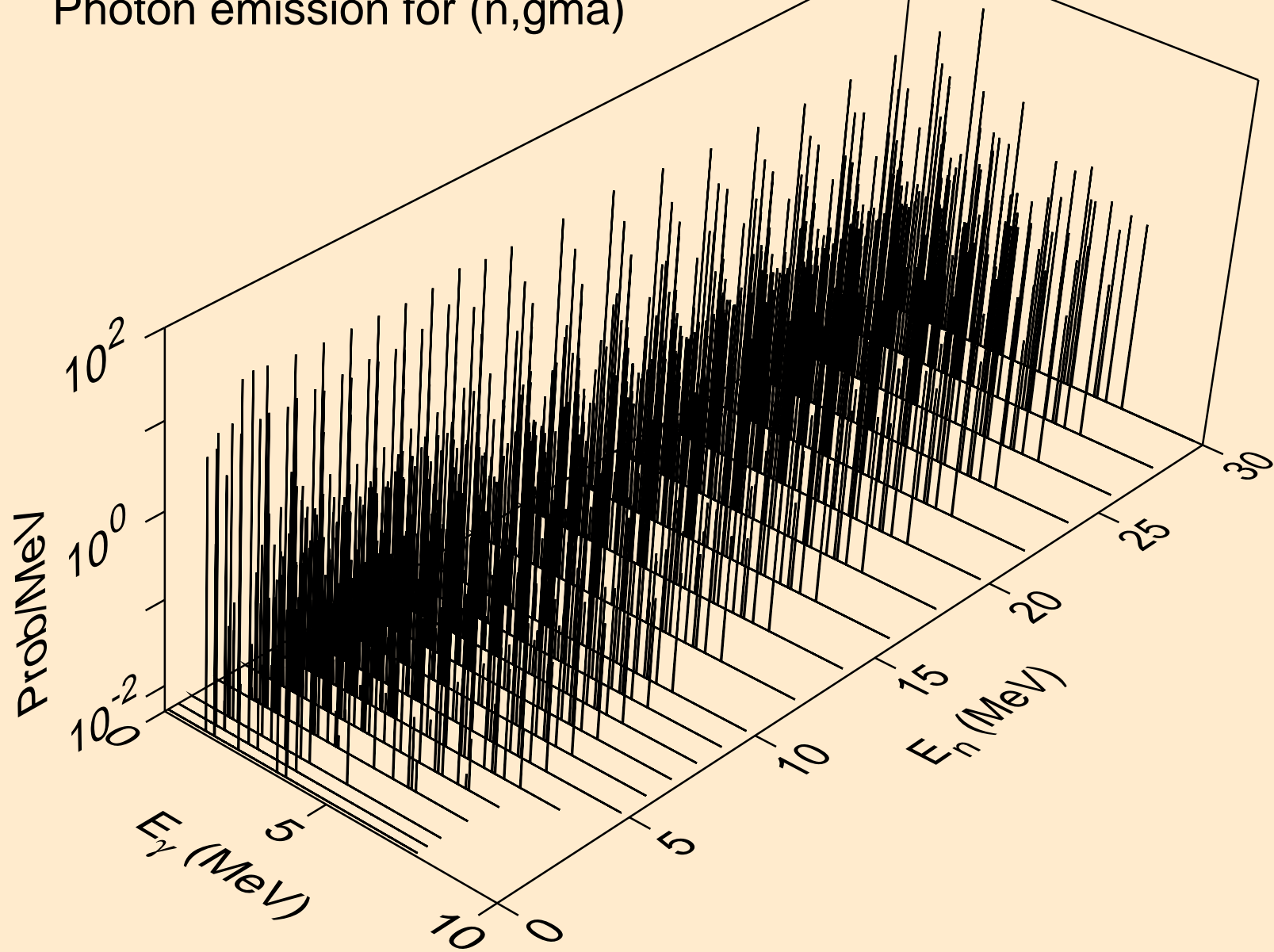

P029 PROTON ACER TENDL-2024 LIBRARY; T=0.K  
Photon emission for inelastic

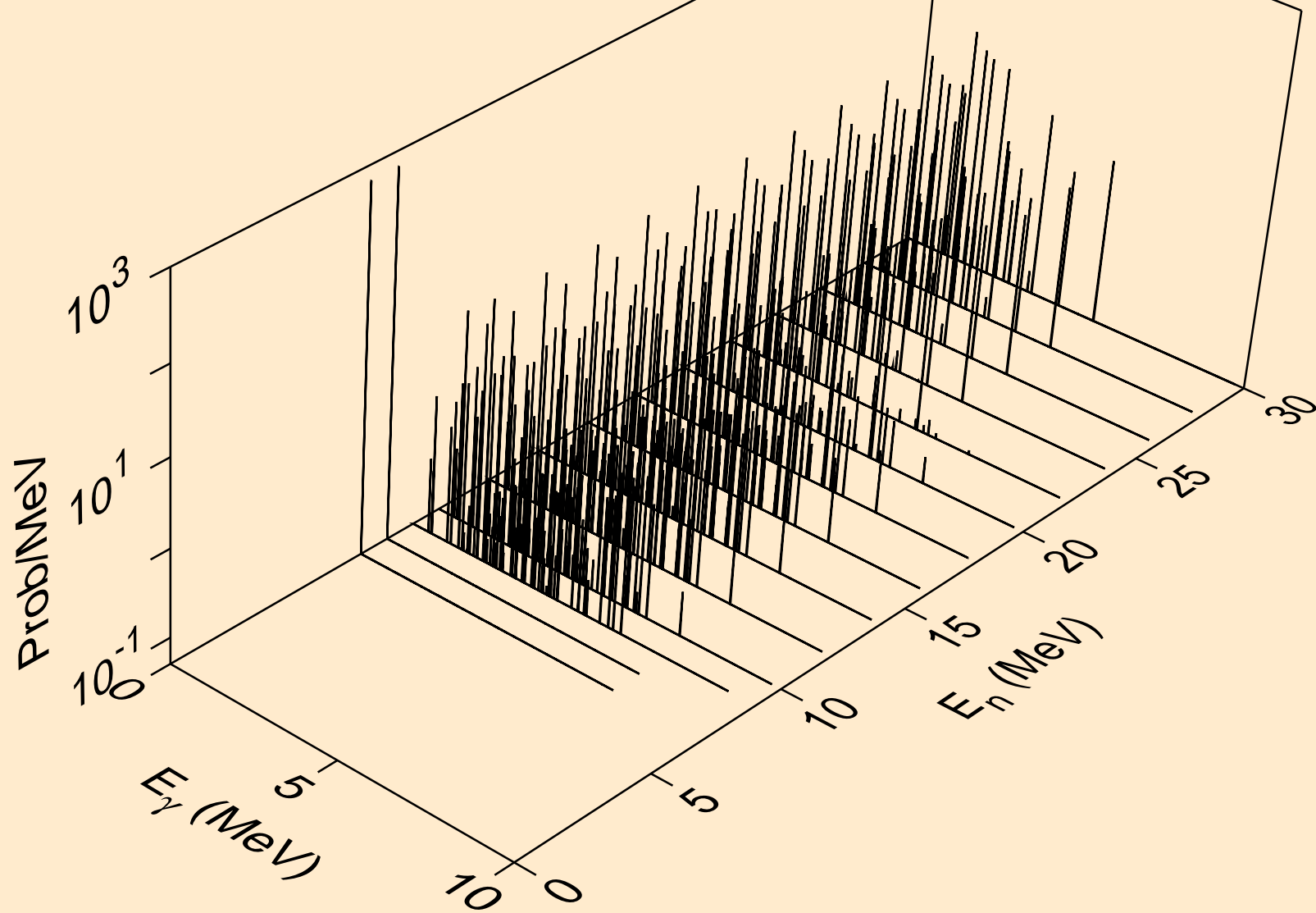

P029 PROTON ACER TENDL-2024 LIBRARY; T=0.K  
Photon emission for (n,d)

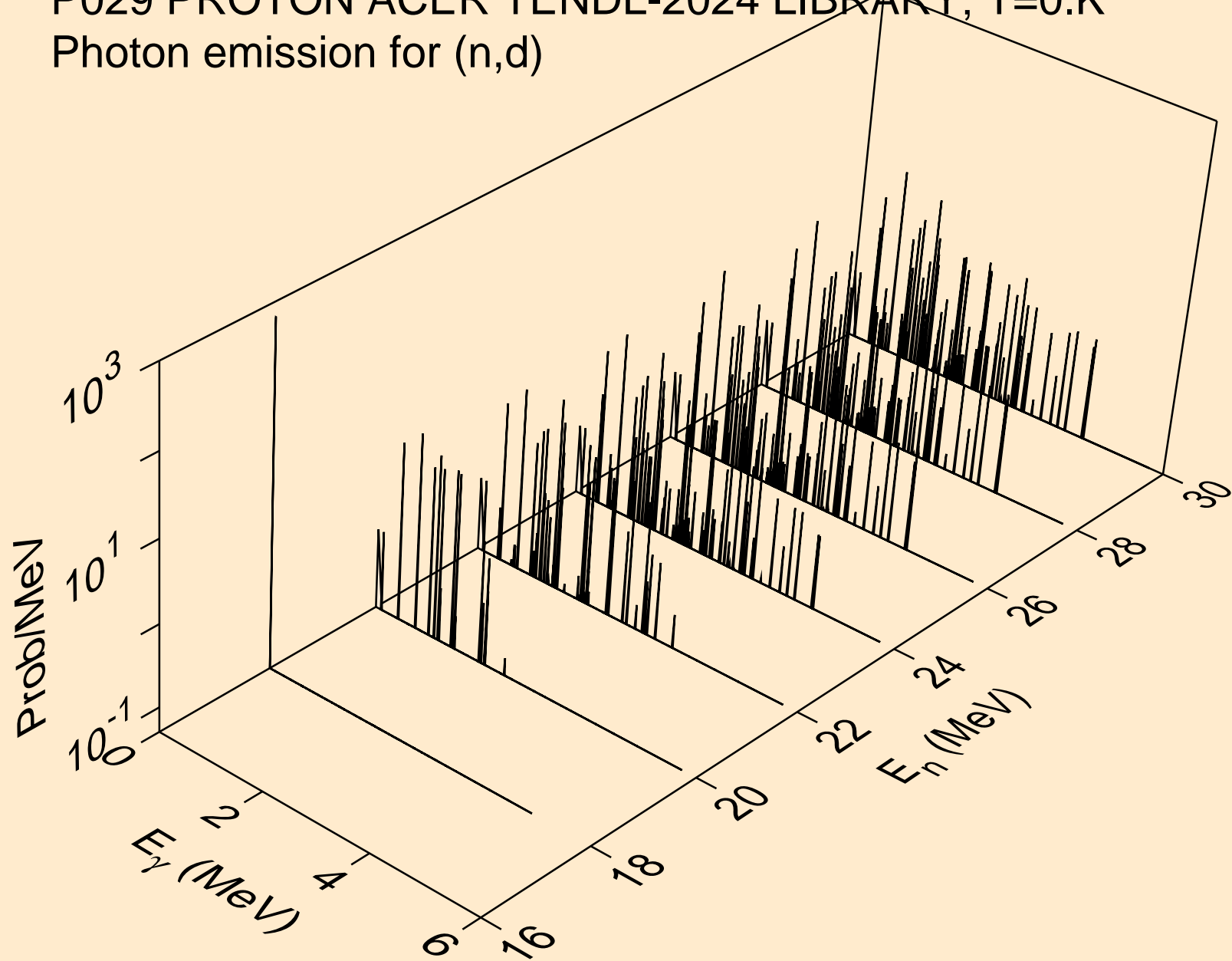

P029 PROTON ACER TENDL-2024 LIBRARY; T=0.K  
Photon emission for (n,t)

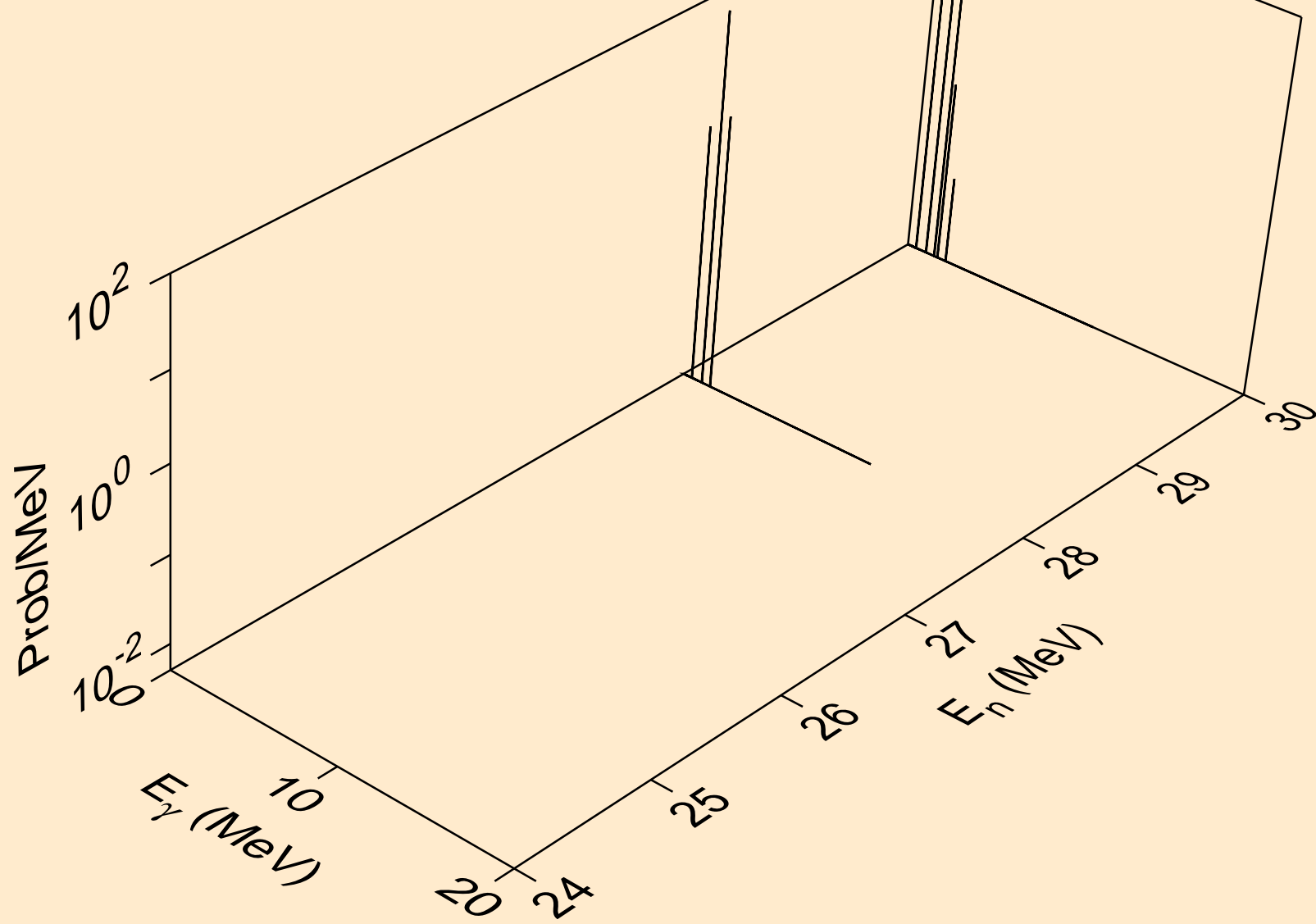

P029 PROTON ACER TENDL-2024 LIBRARY; T=0.K  
Photon emission for (n,he3)

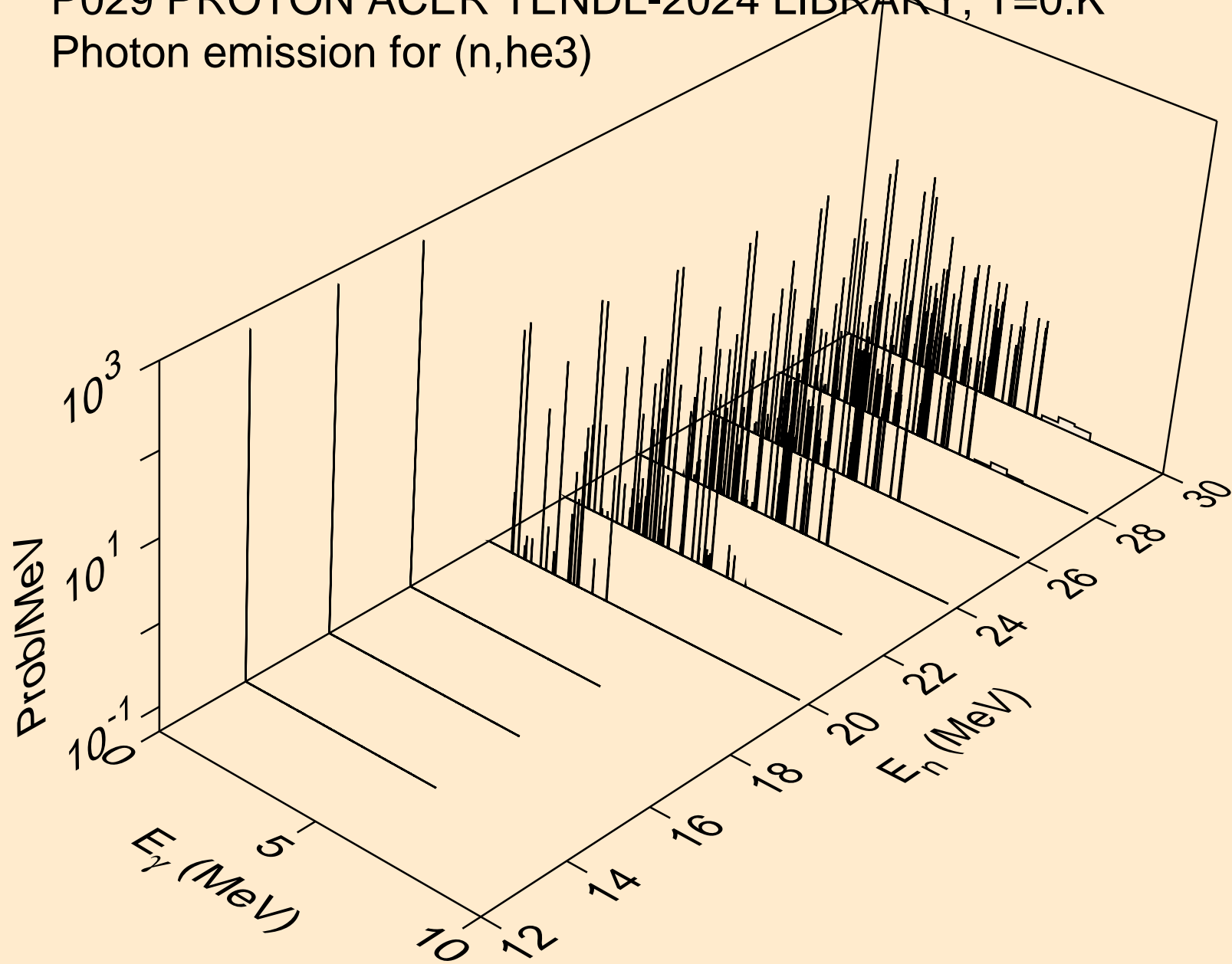

P029 PROTON ACER TENDL-2024 LIBRARY; T=0.K  
Photon emission for (n,a)

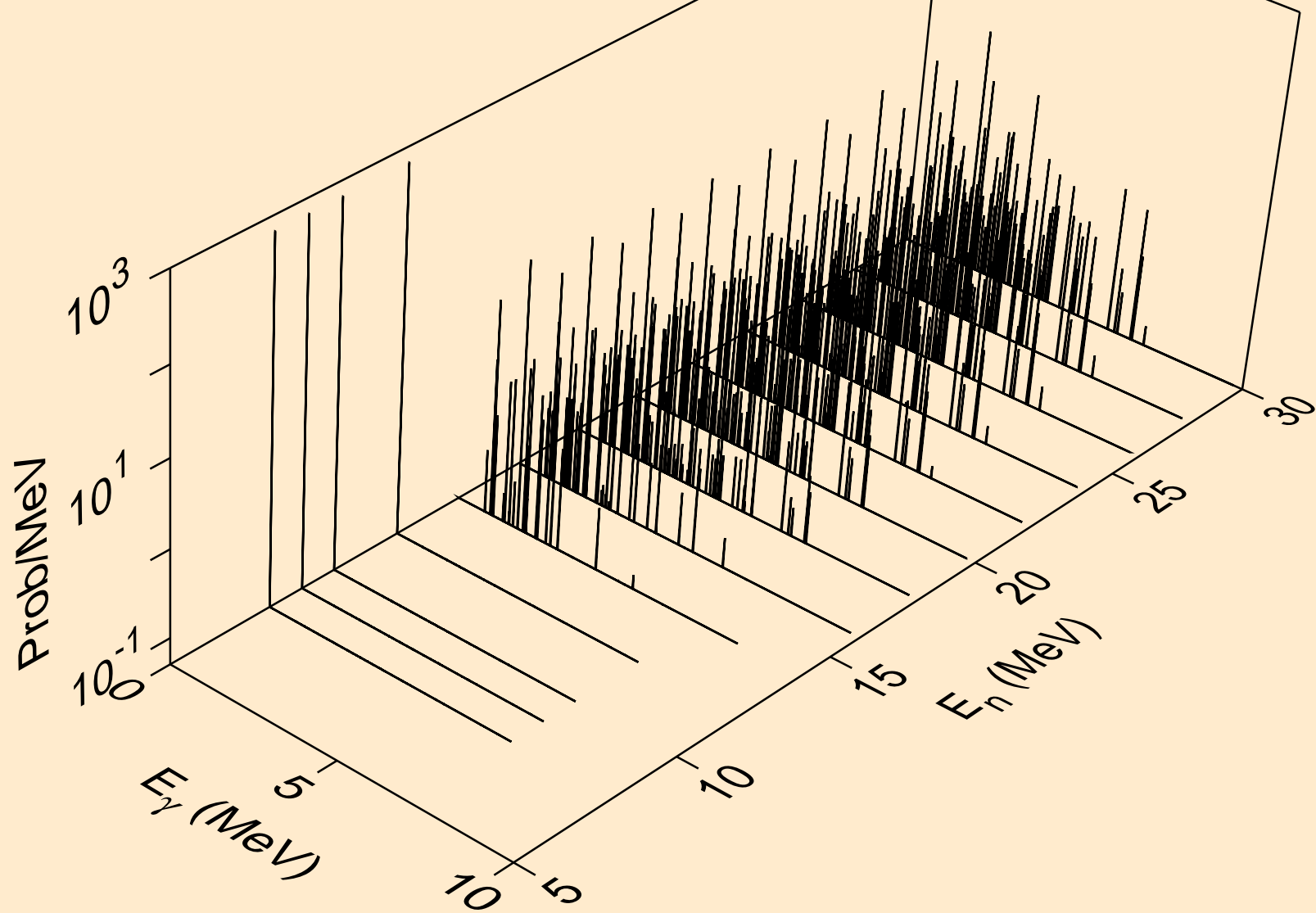

P029 PROTON ACER TENDL-2024 LIBRARY; T=0.K  
Photon emission for (n,2a)

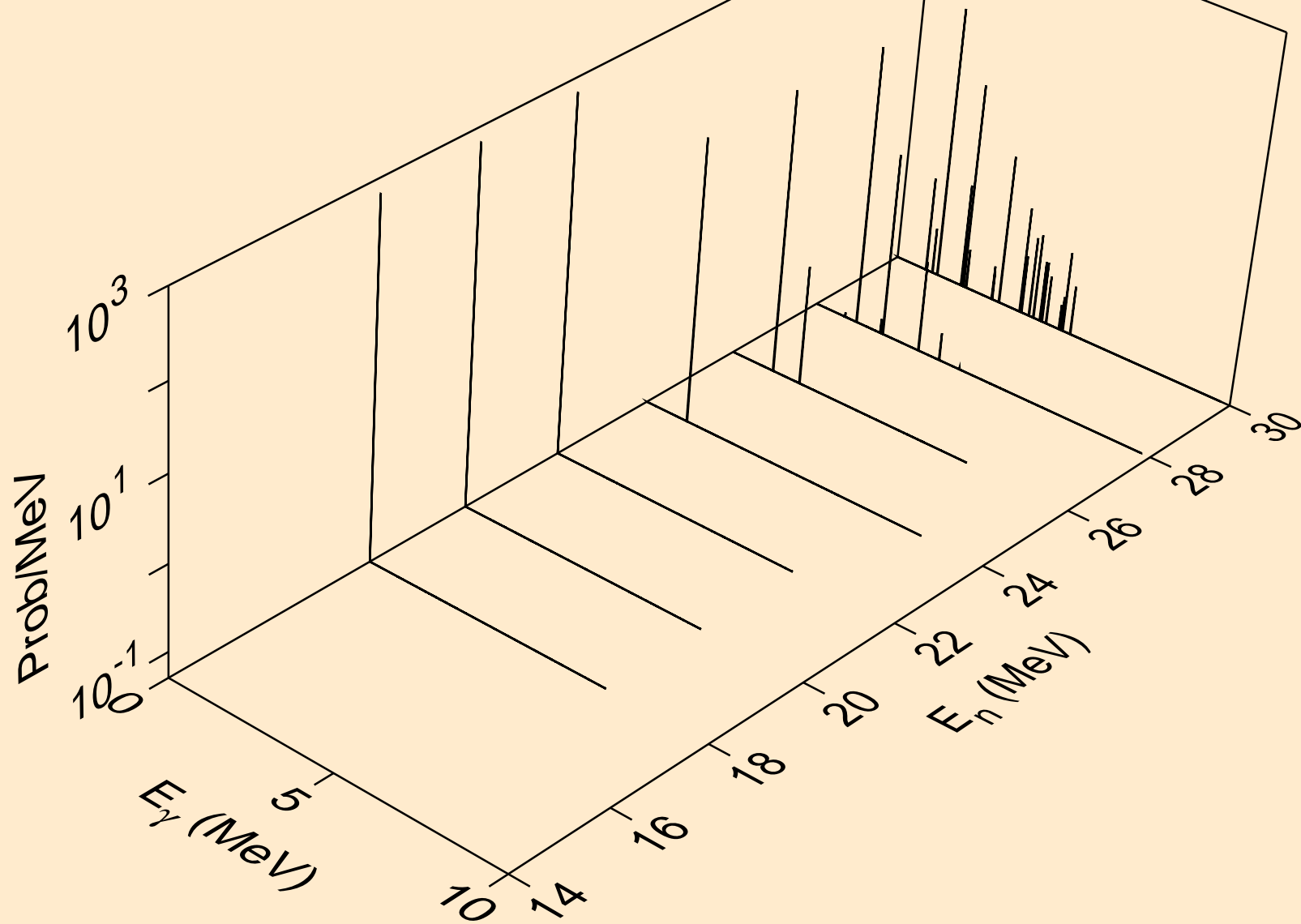

P029 PROTON ACER TENDL-2024 LIBRARY; T=0.K  
Photon emission for (n,2p)

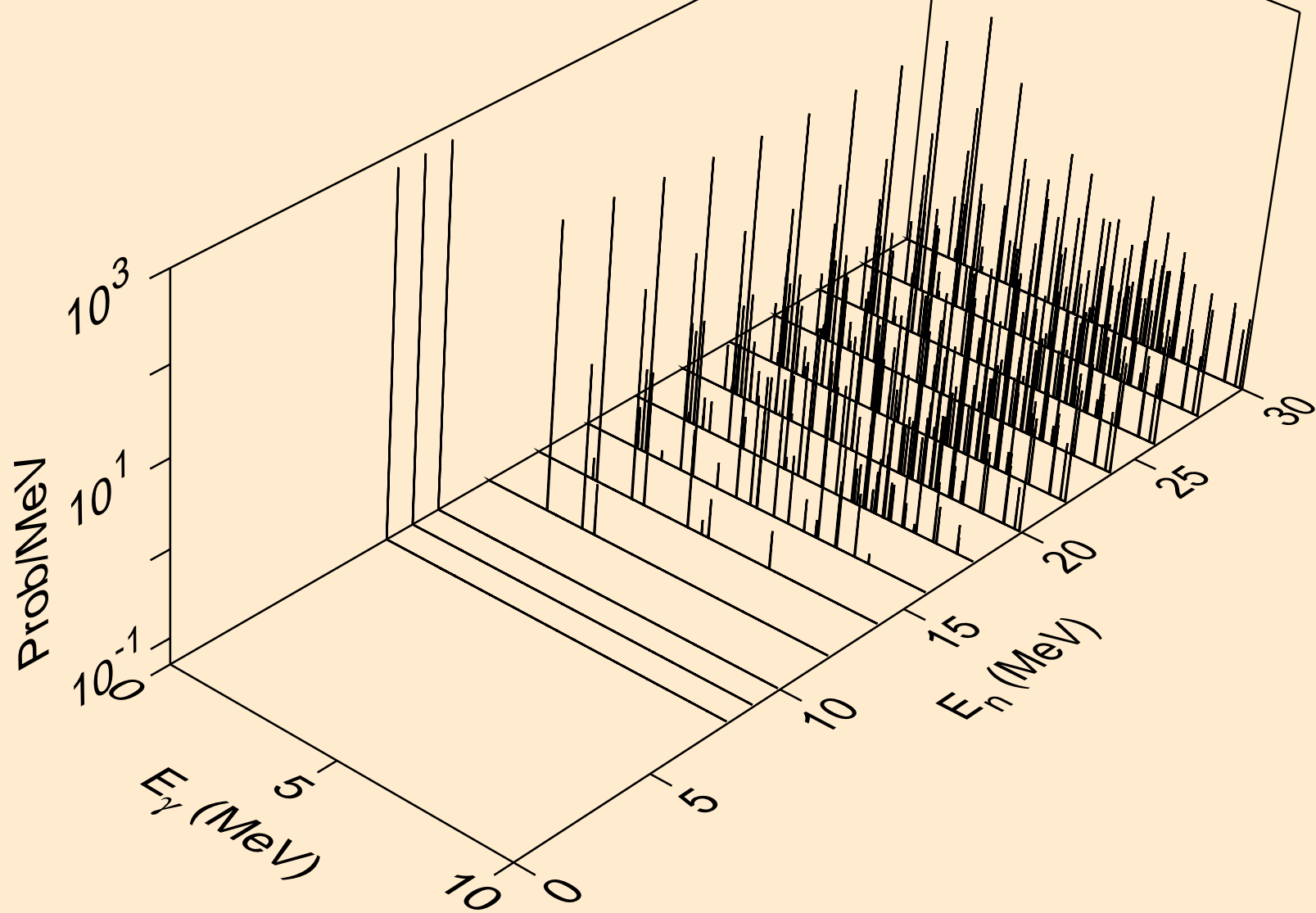

P029 PROTON ACER TENDL-2024 LIBRARY; T=0.K  
Photon emission for (n,pa)

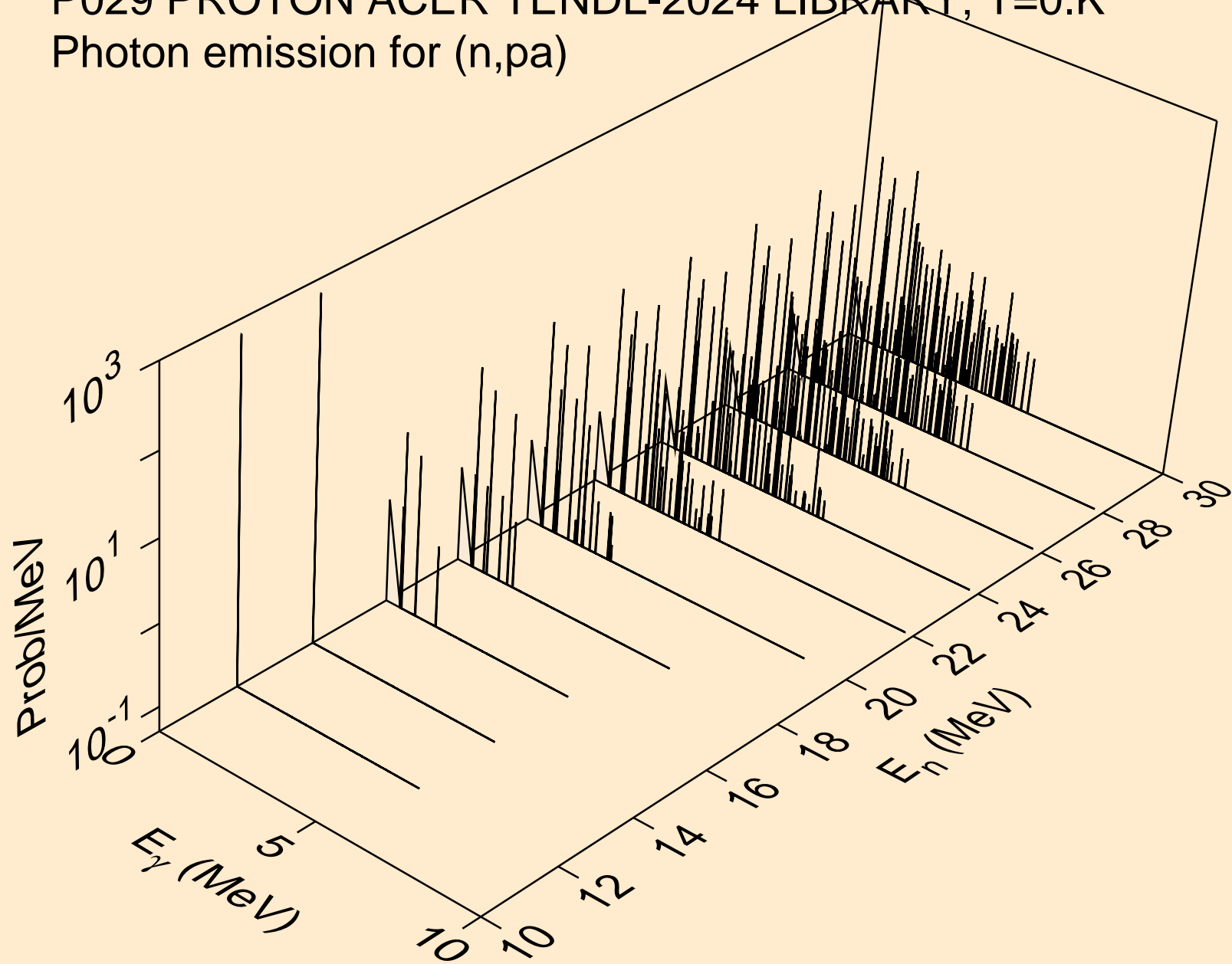

P029 PROTON ACER TENDL-2024 LIBRARY; T=0.K  
Photon emission for (n,pd)

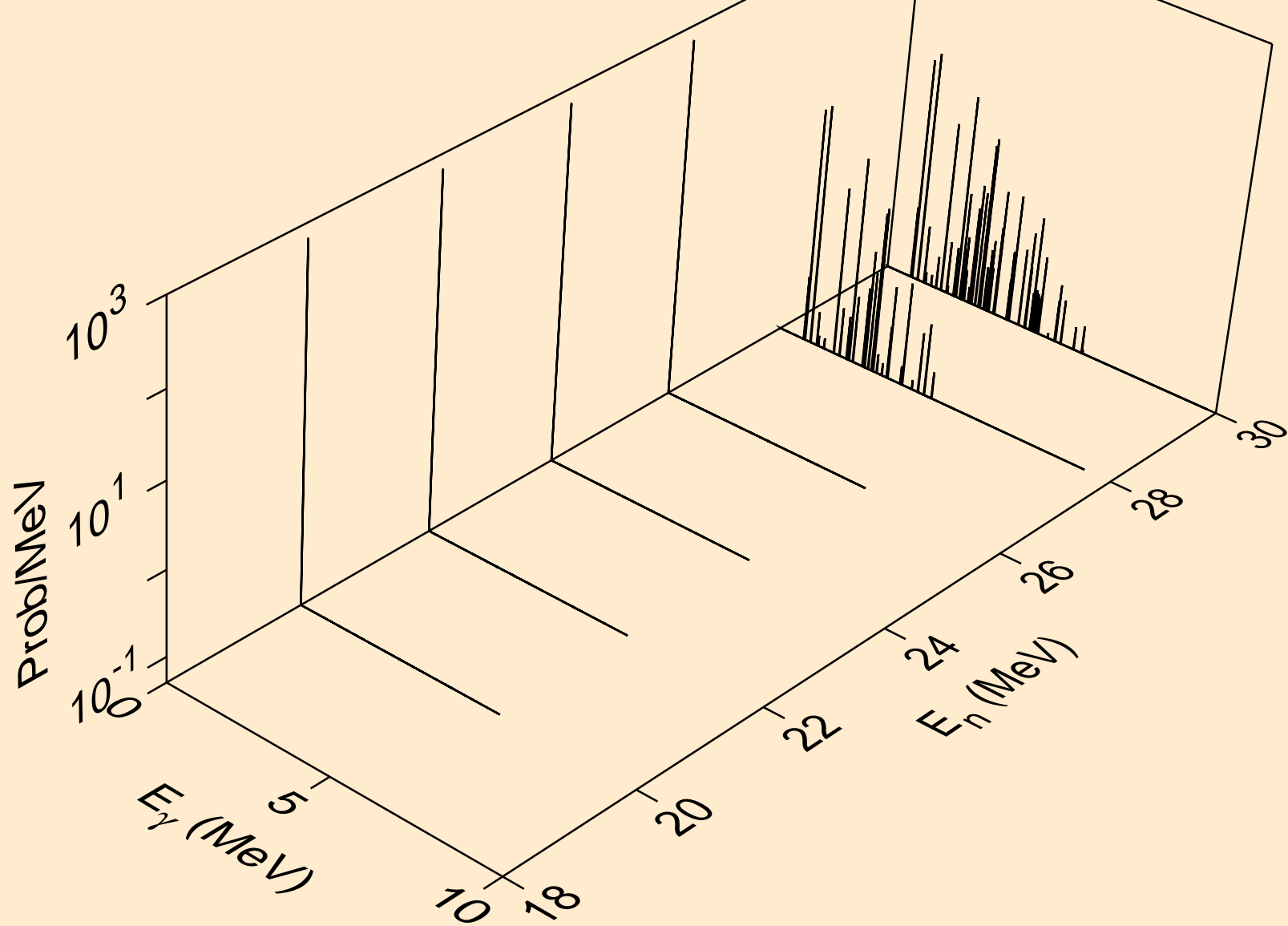

P029 PROTON ACER TENDL-2024 LIBRARY; T=0.K  
Photon emission for (n,pt)

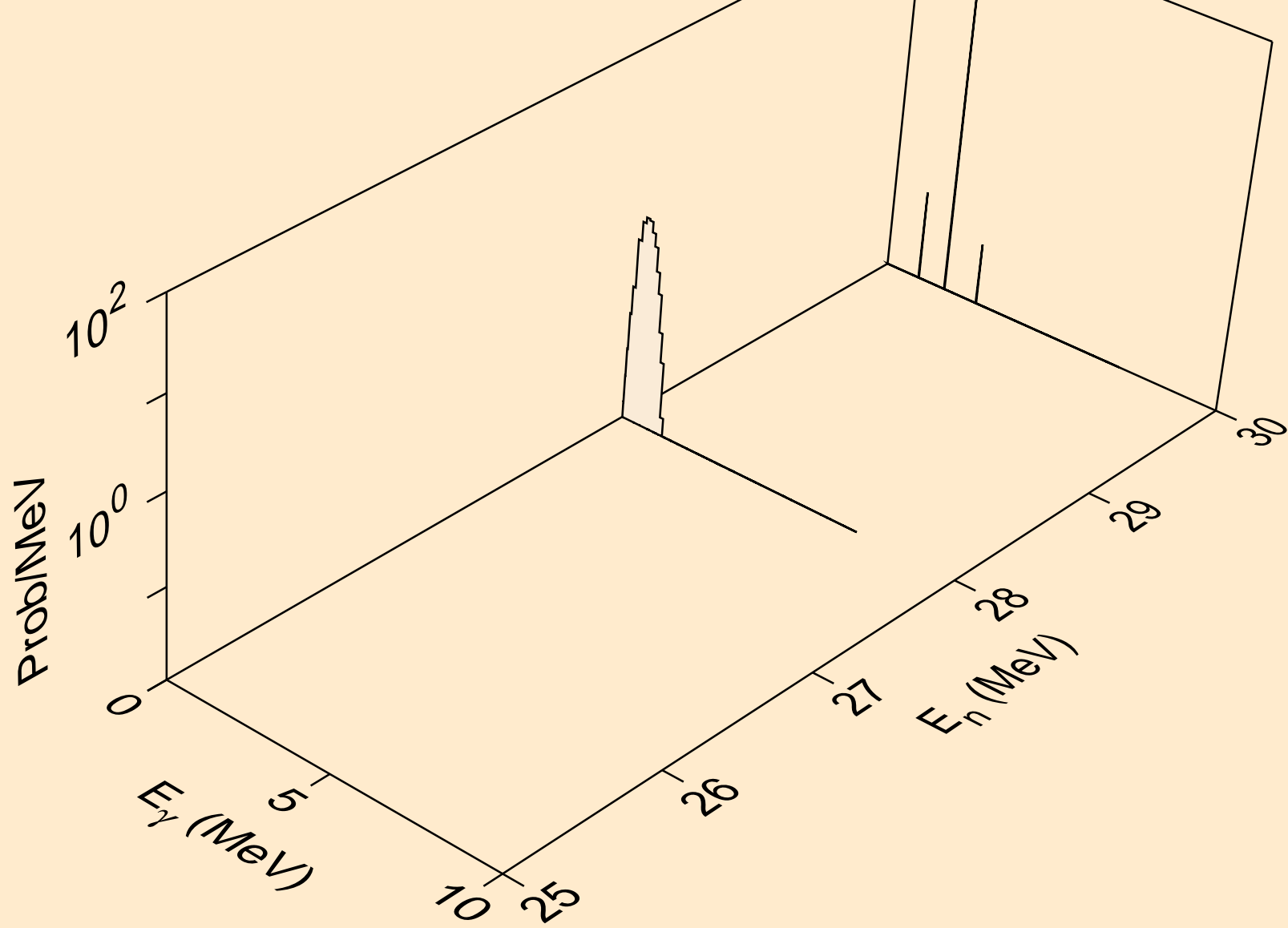

P029 PROTON ACER TENDL-2024 LIBRARY; T=0.K  
Particle heating contributions

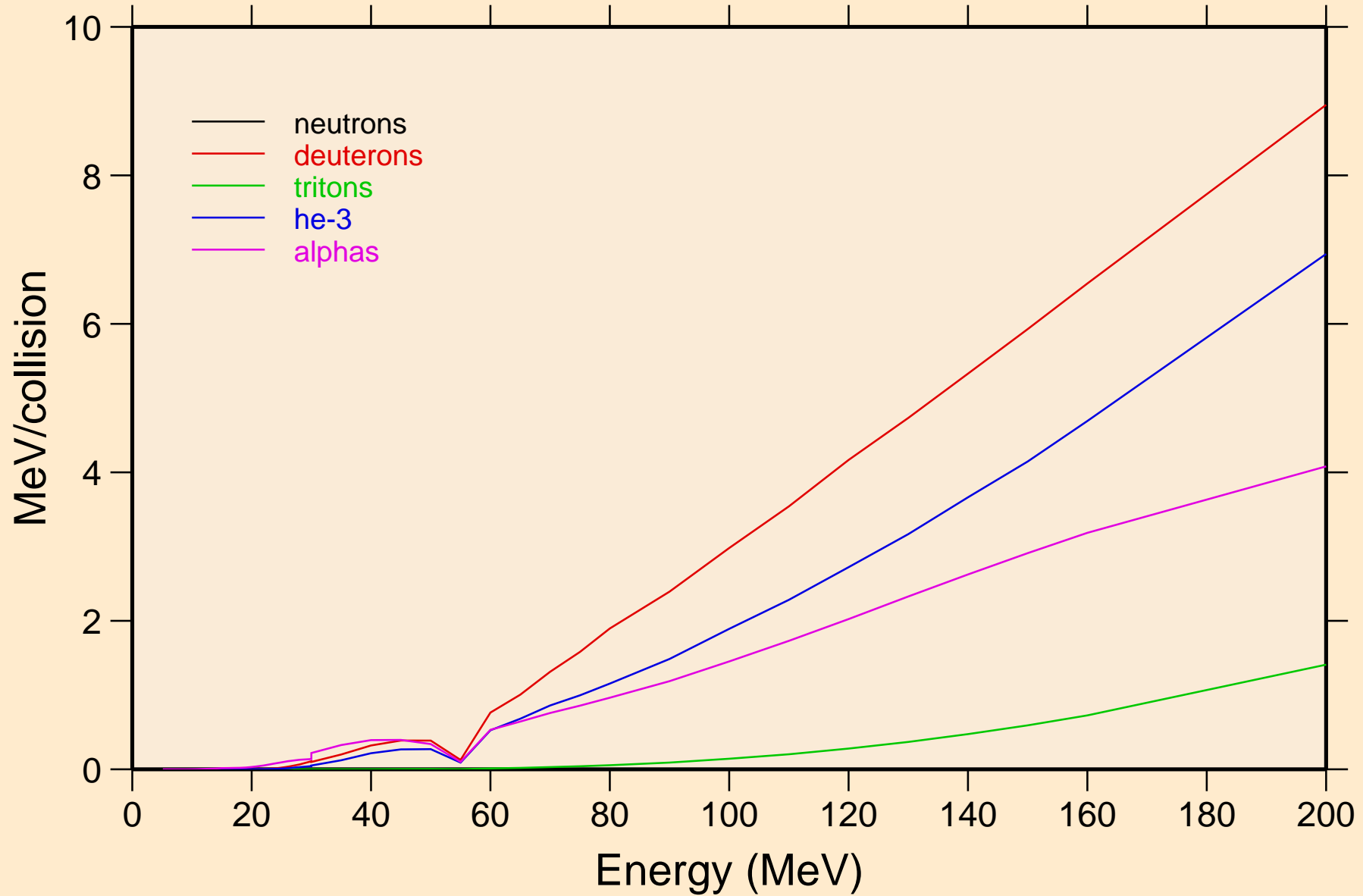

P029 PROTON ACER TENDL-2024 LIBRARY; T=0.K  
Recoil Heating

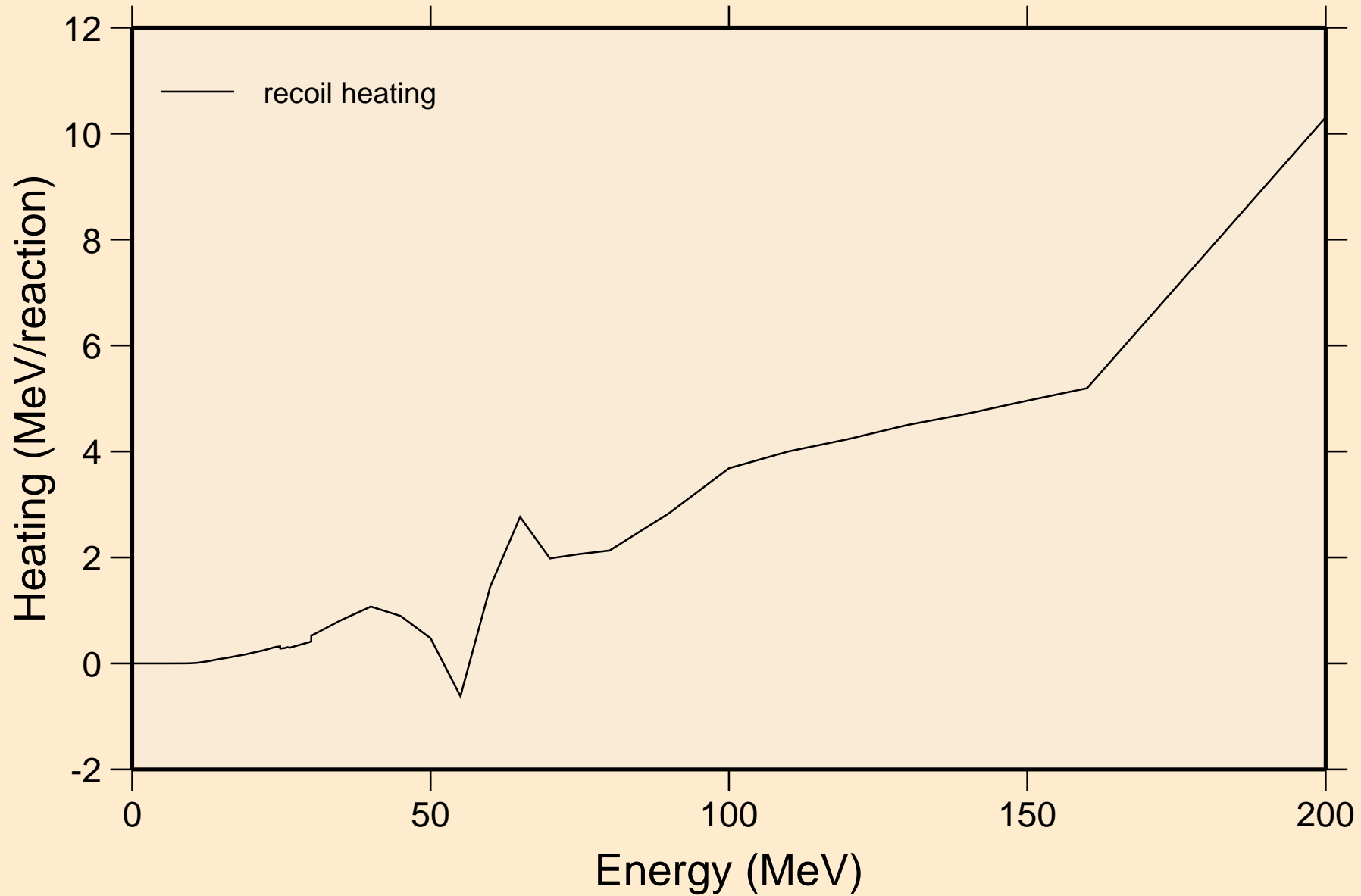

P029 PROTON ACER TENDL-2024 LIBRARY; T=0.K  
Particle production cross sections

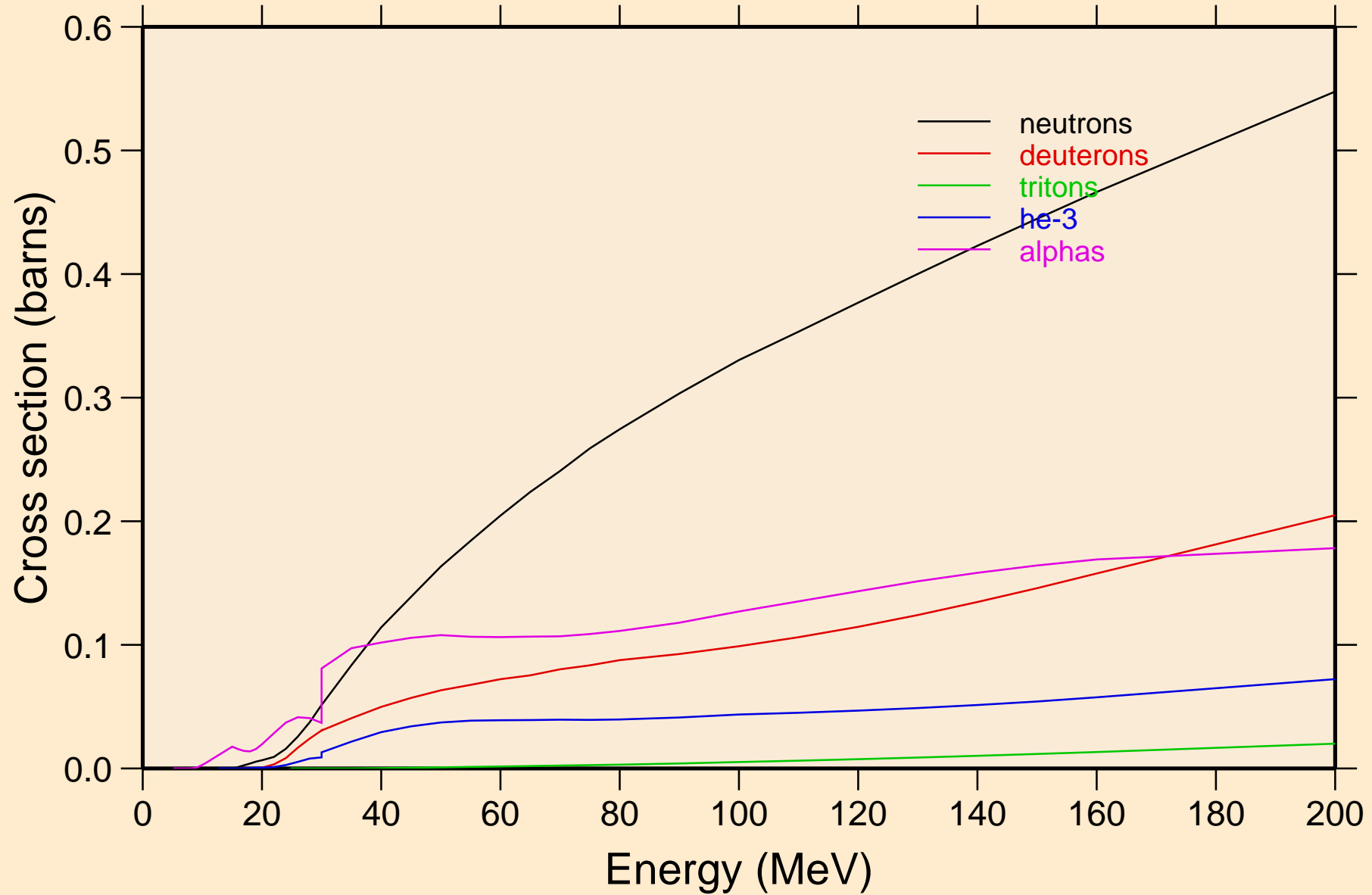

P029 PROTON ACER TENDL-2024 LIBRARY; T=0.K  
neutrons from (p,n)

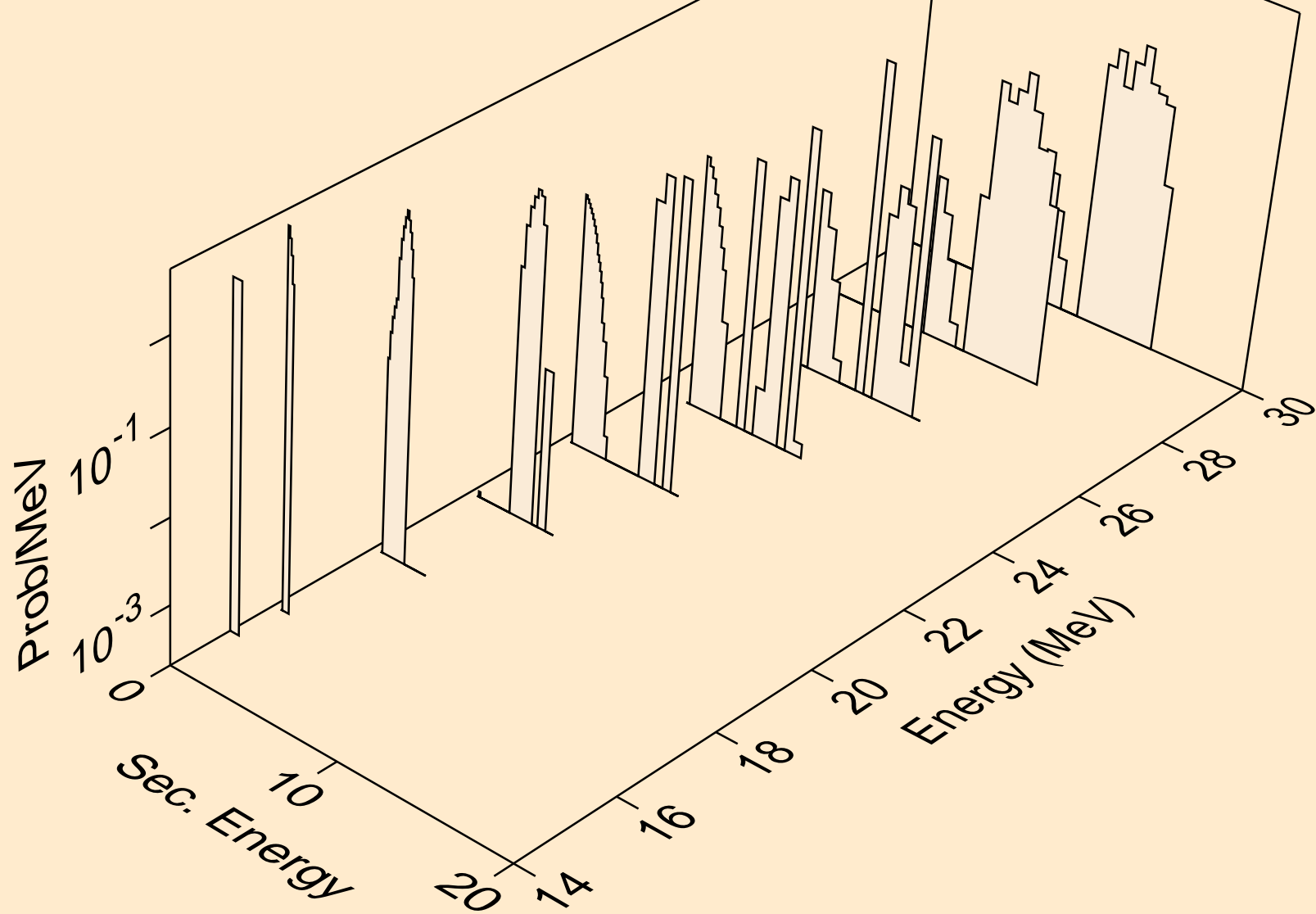

P029 PROTON ACER TENDL-2024 LIBRARY; T=0.K  
neutrons from (p,x)

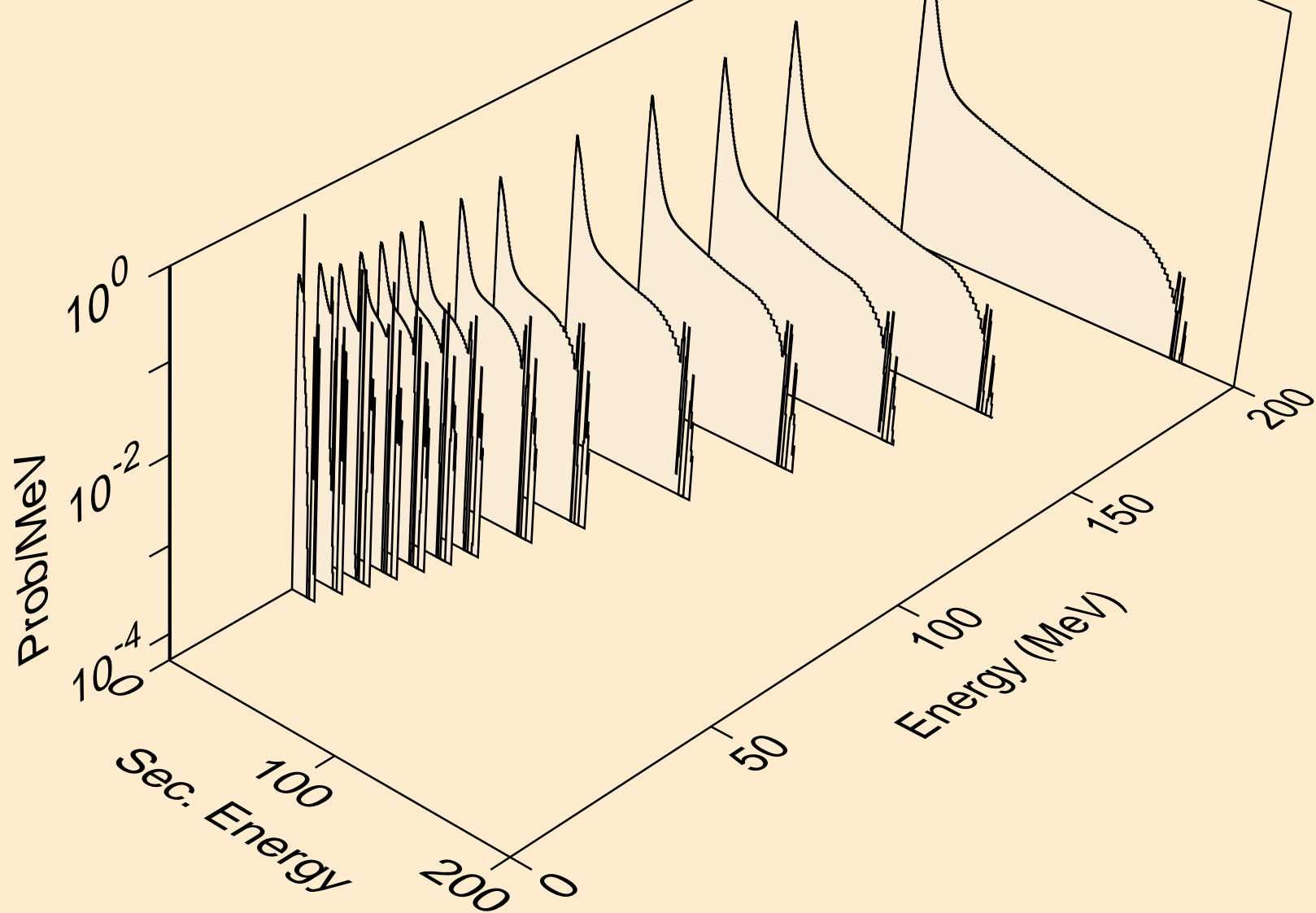

P029 PROTON ACER TENDL-2024 LIBRARY; T=0.K  
neutrons from (p,n\*)a

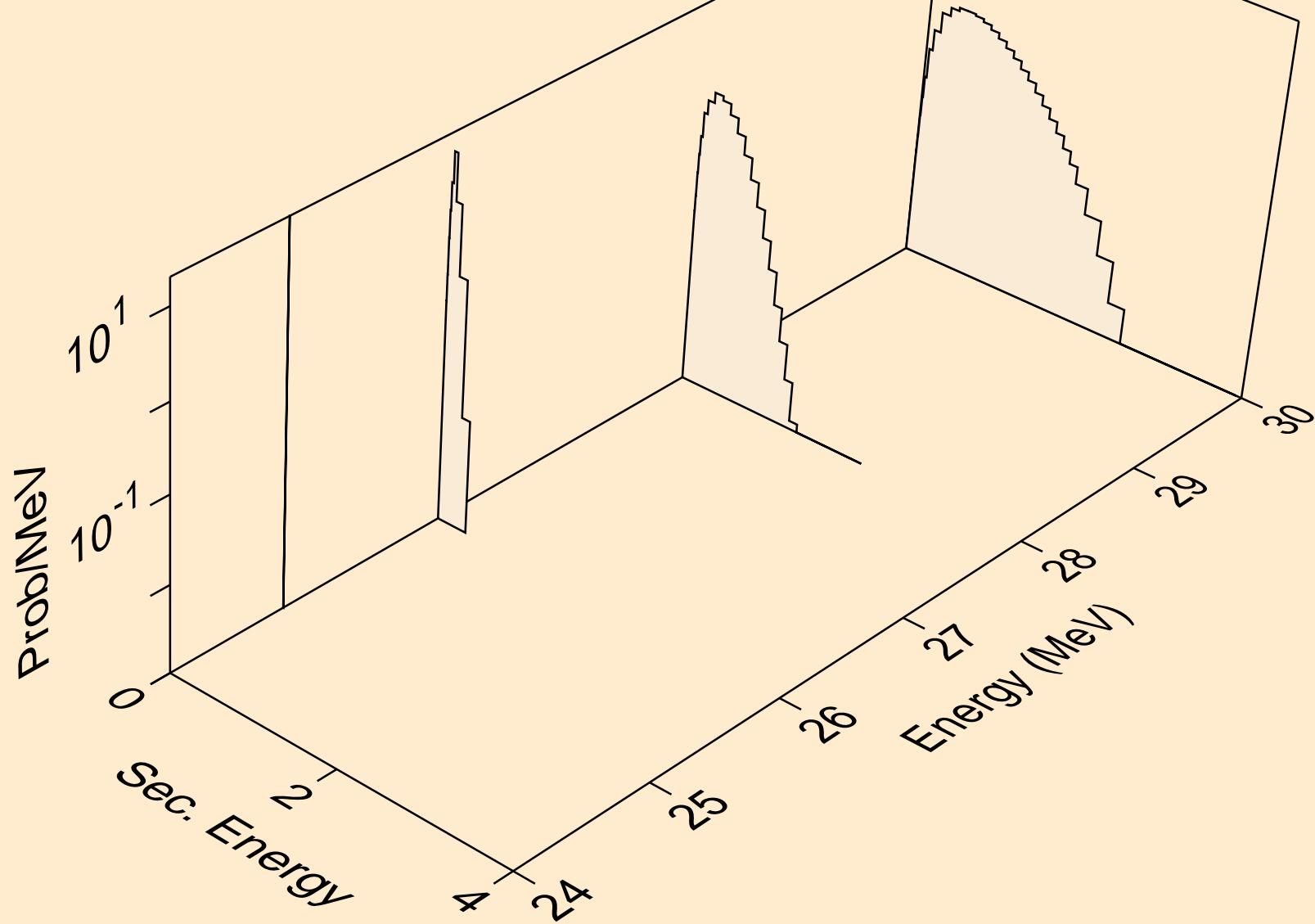

P029 PROTON ACER TENDL-2024 LIBRARY; T=0.K  
neutrons from (p,n\*)p

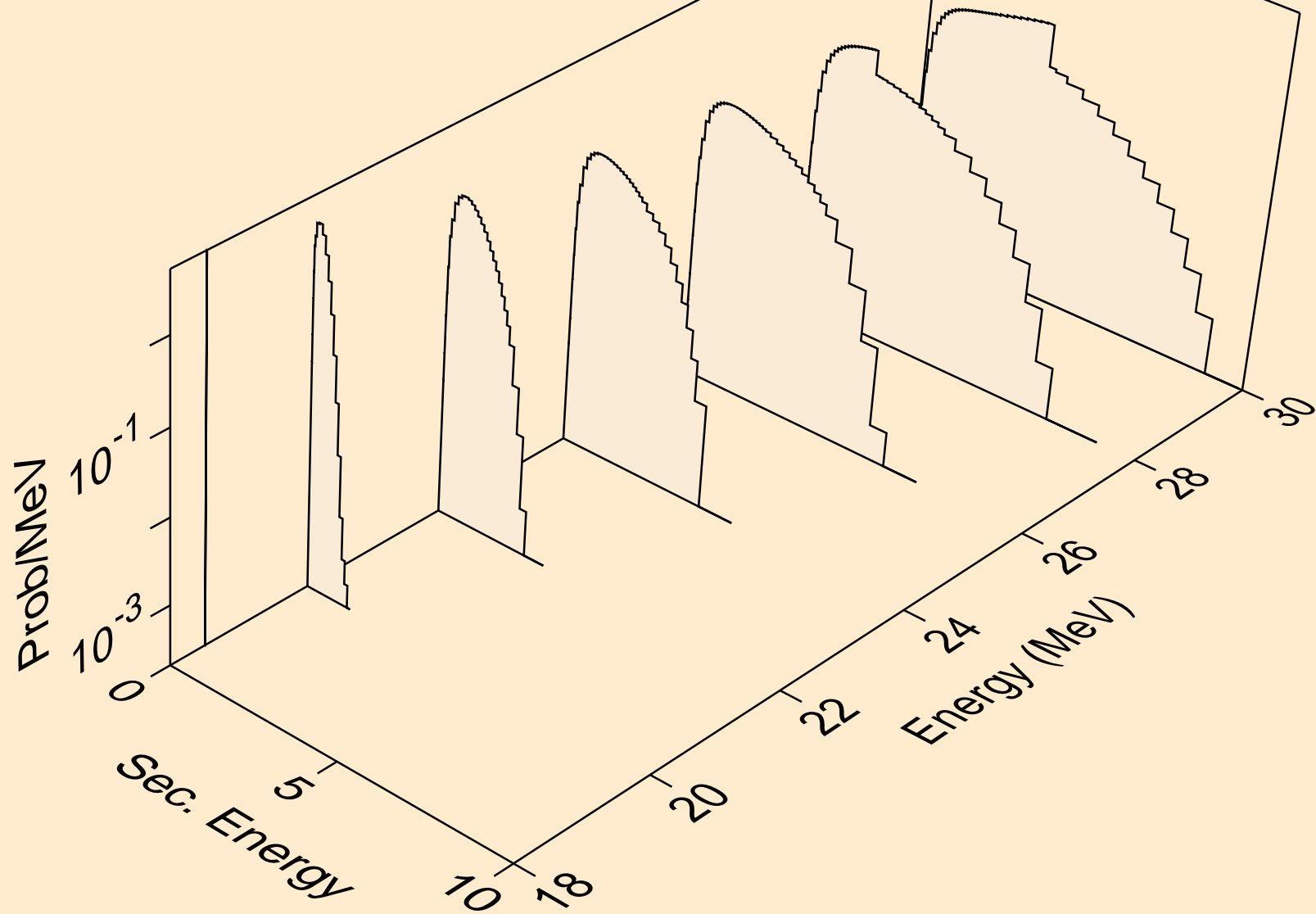

P029 PROTON ACER TENDL-2024 LIBRARY; T=0.K  
neutrons from (p,n\*)he3

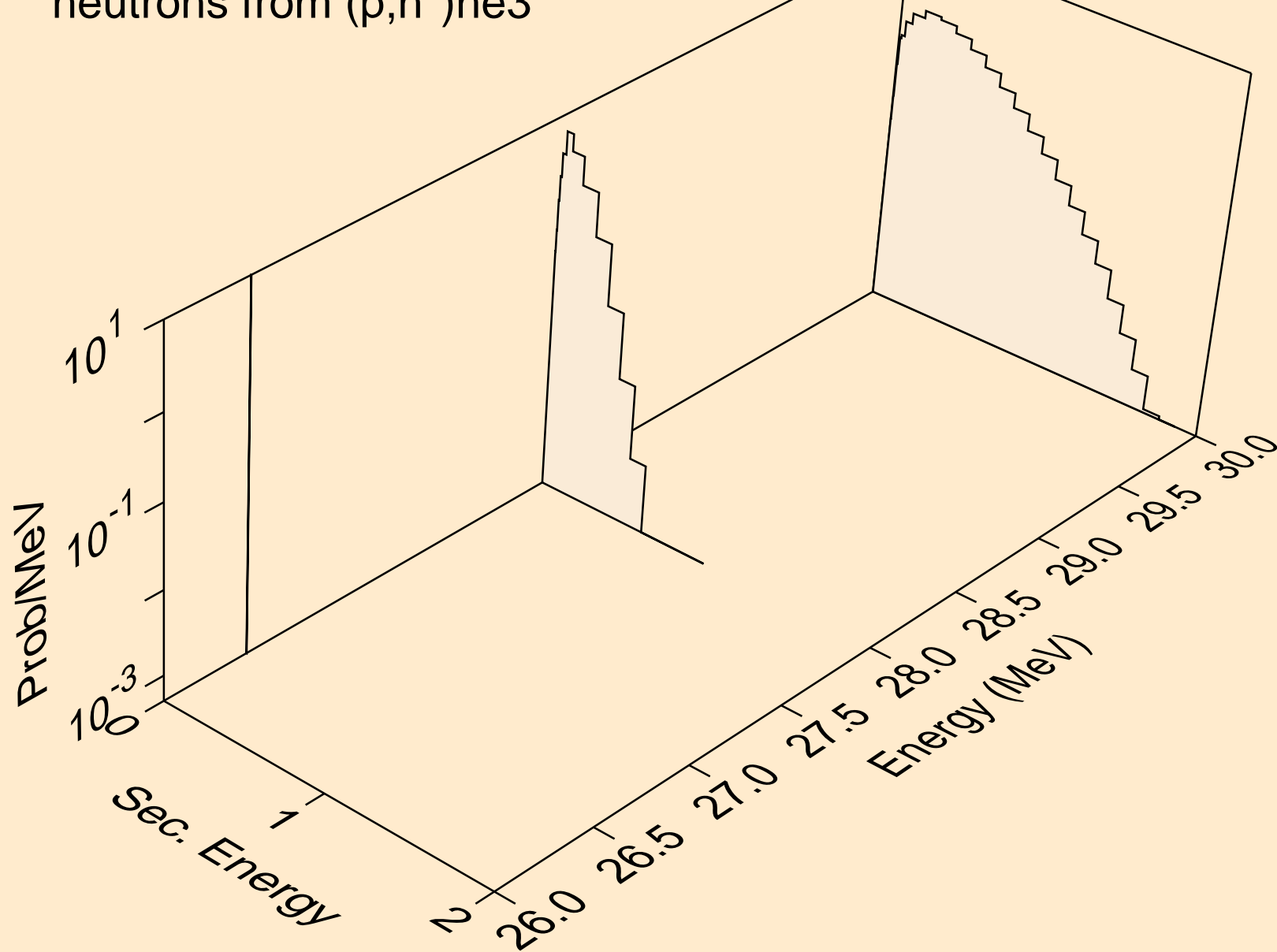

P029 PROTON ACER TENDL-2024 LIBRARY; T=0.K  
neutrons from (p,n2p)

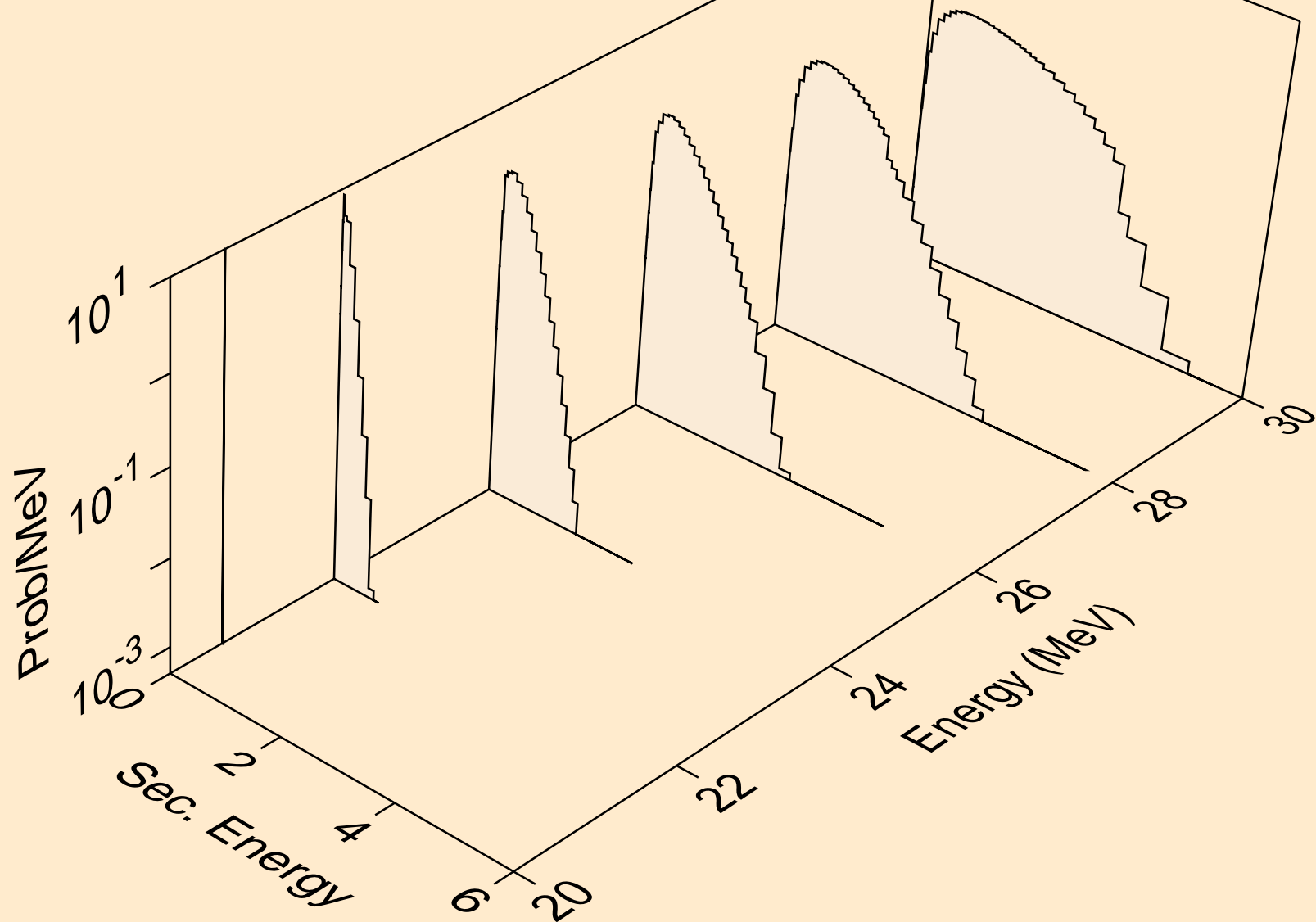

P029 PROTON ACER TENDL-2024 LIBRARY; T=0.K  
deuterons from (p,x)

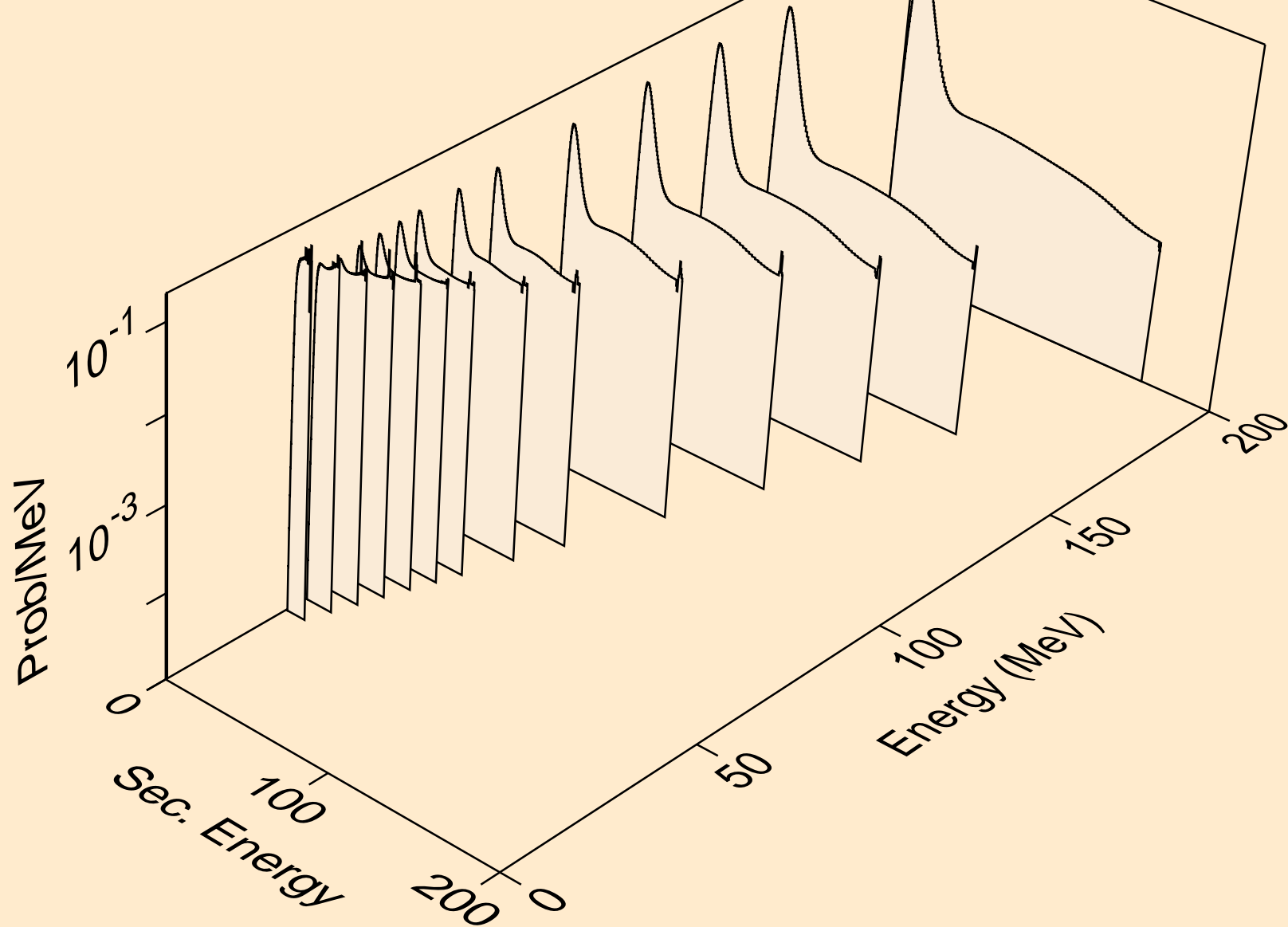

P029 PROTON ACER TENDL-2024 LIBRARY; T=0.K  
deuterons from (p,d)

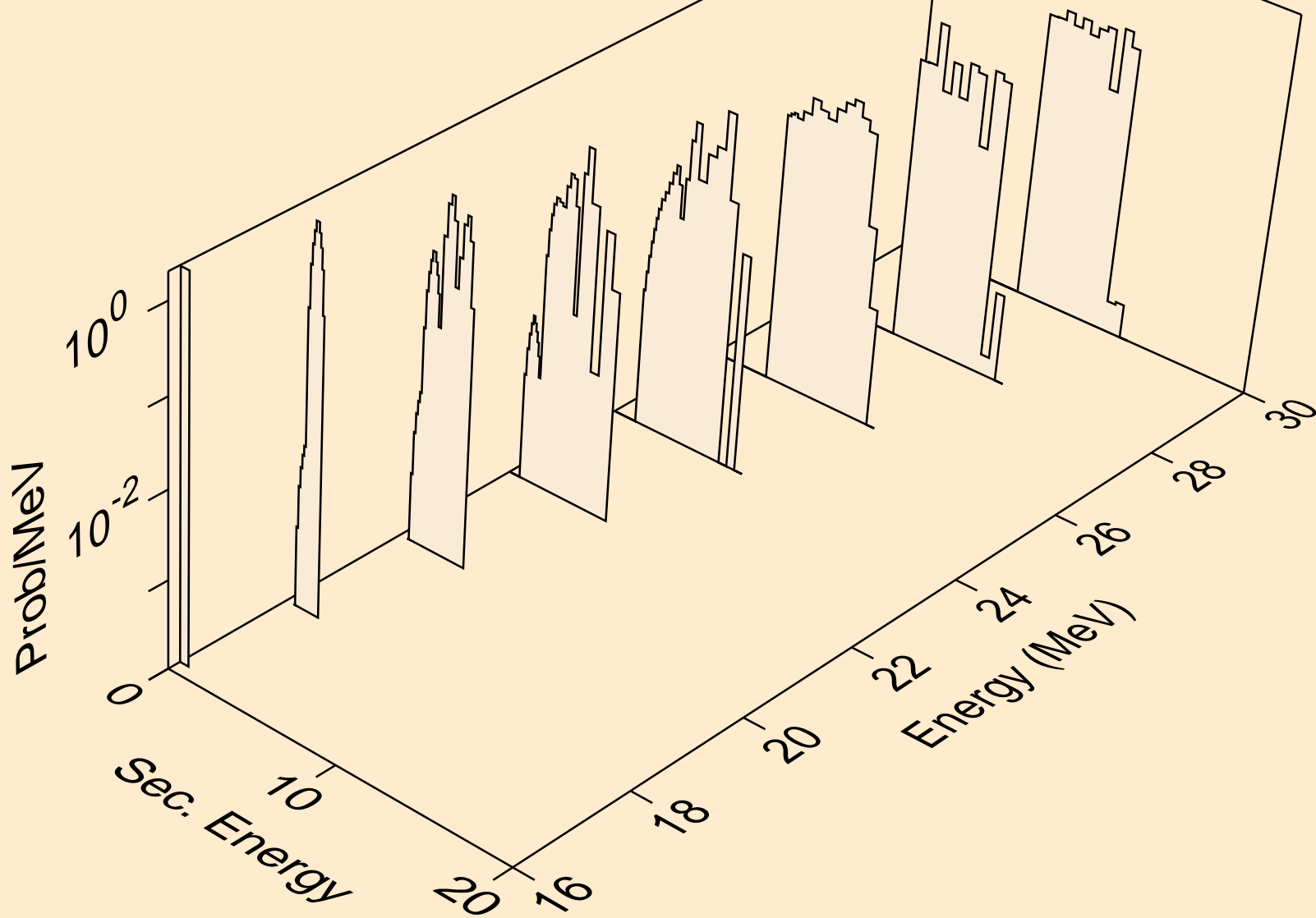

P029 PROTON ACER TENDL-2024 LIBRARY; T=0.K  
deuterons from (p,pd)

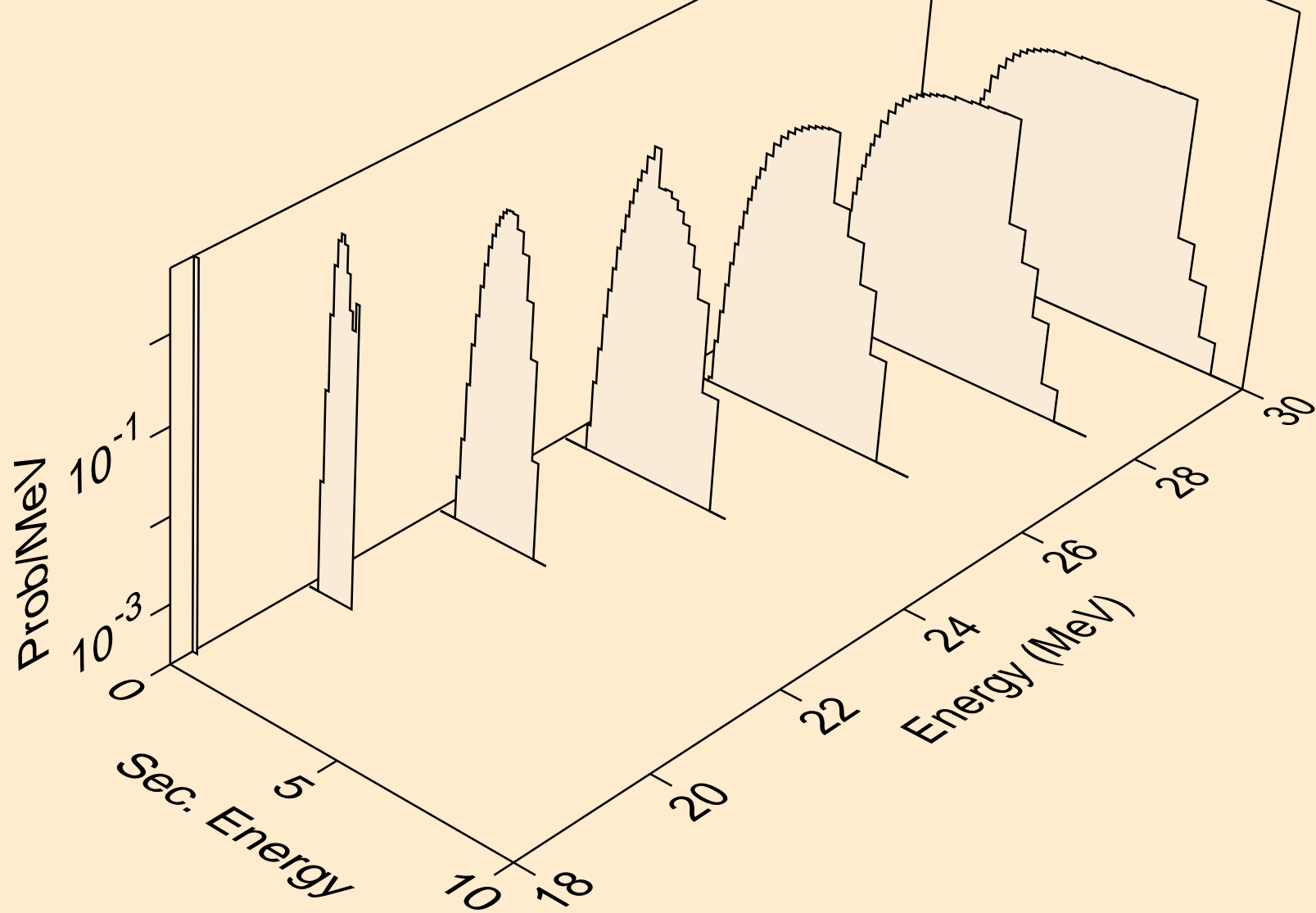

P029 PROTON ACER TENDL-2024 LIBRARY; T=0.K  
tritons from (p,x)

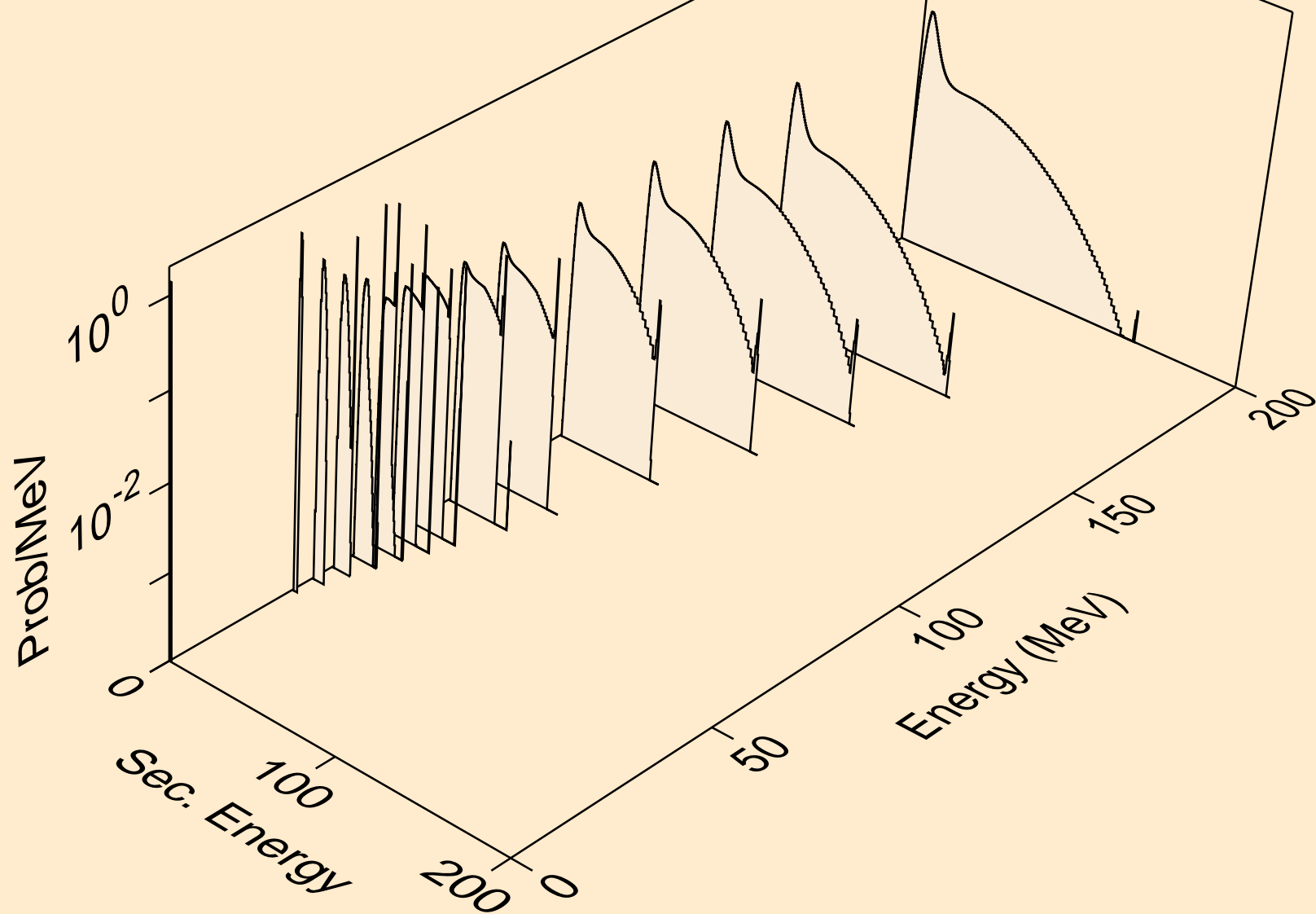

P029 PROTON ACER TENDL-2024 LIBRARY; T=0.K  
tritons from (p,t)

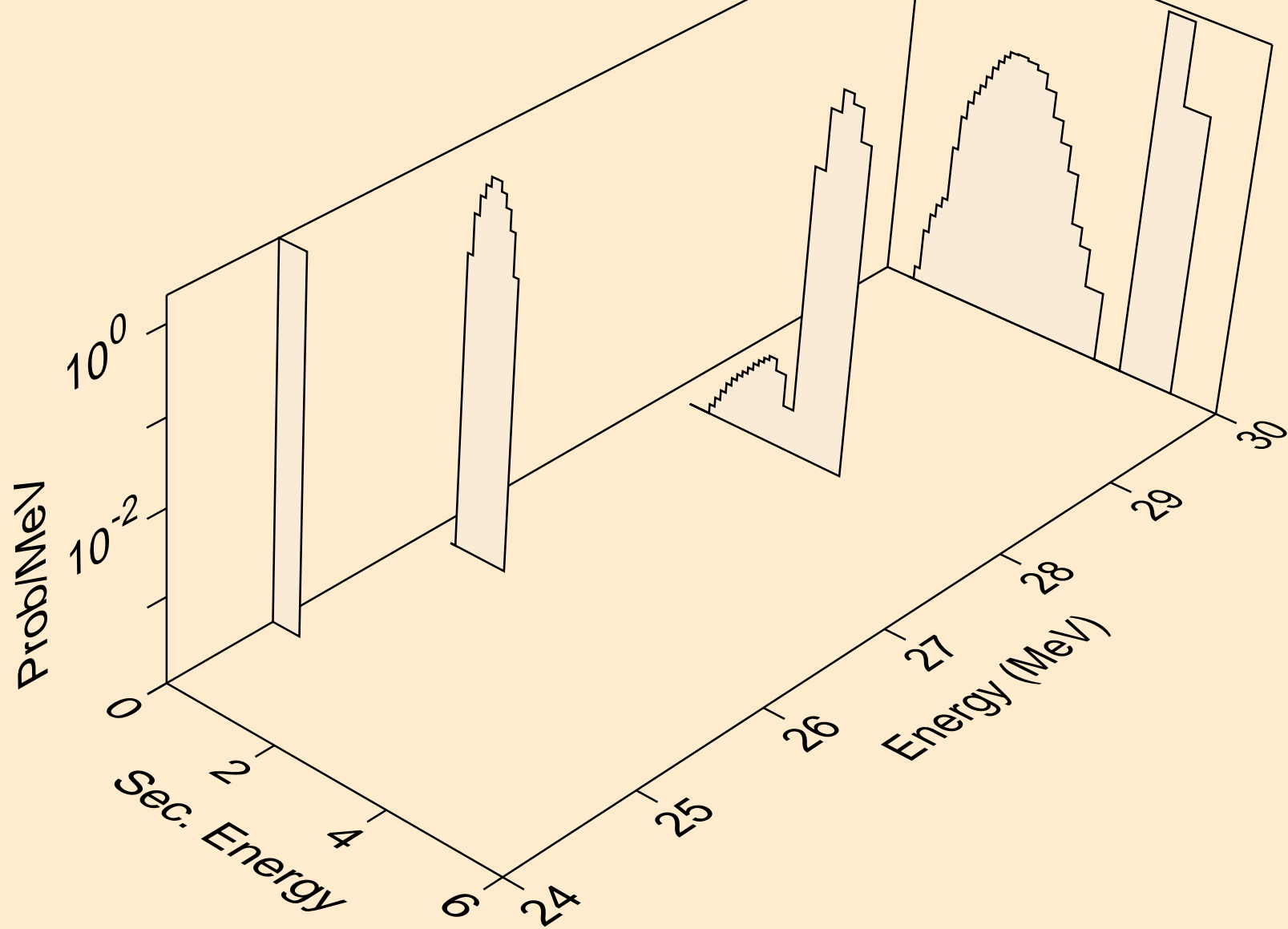

P029 PROTON ACER TENDL-2024 LIBRARY; T=0.K  
tritons from (p,pt)

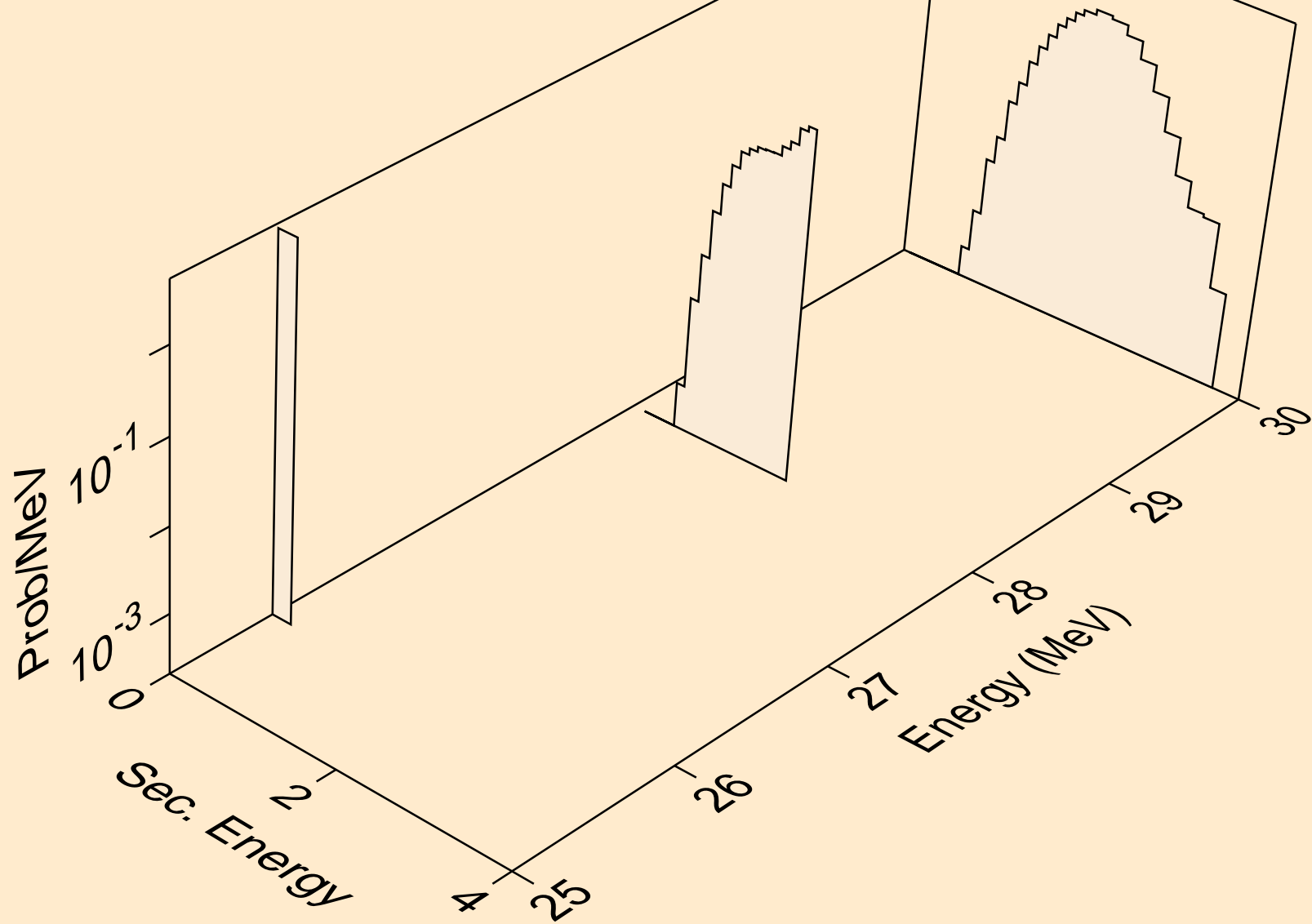

P029 PROTON ACER TENDL-2024 LIBRARY; T=0.K  
he3s from (p,x)

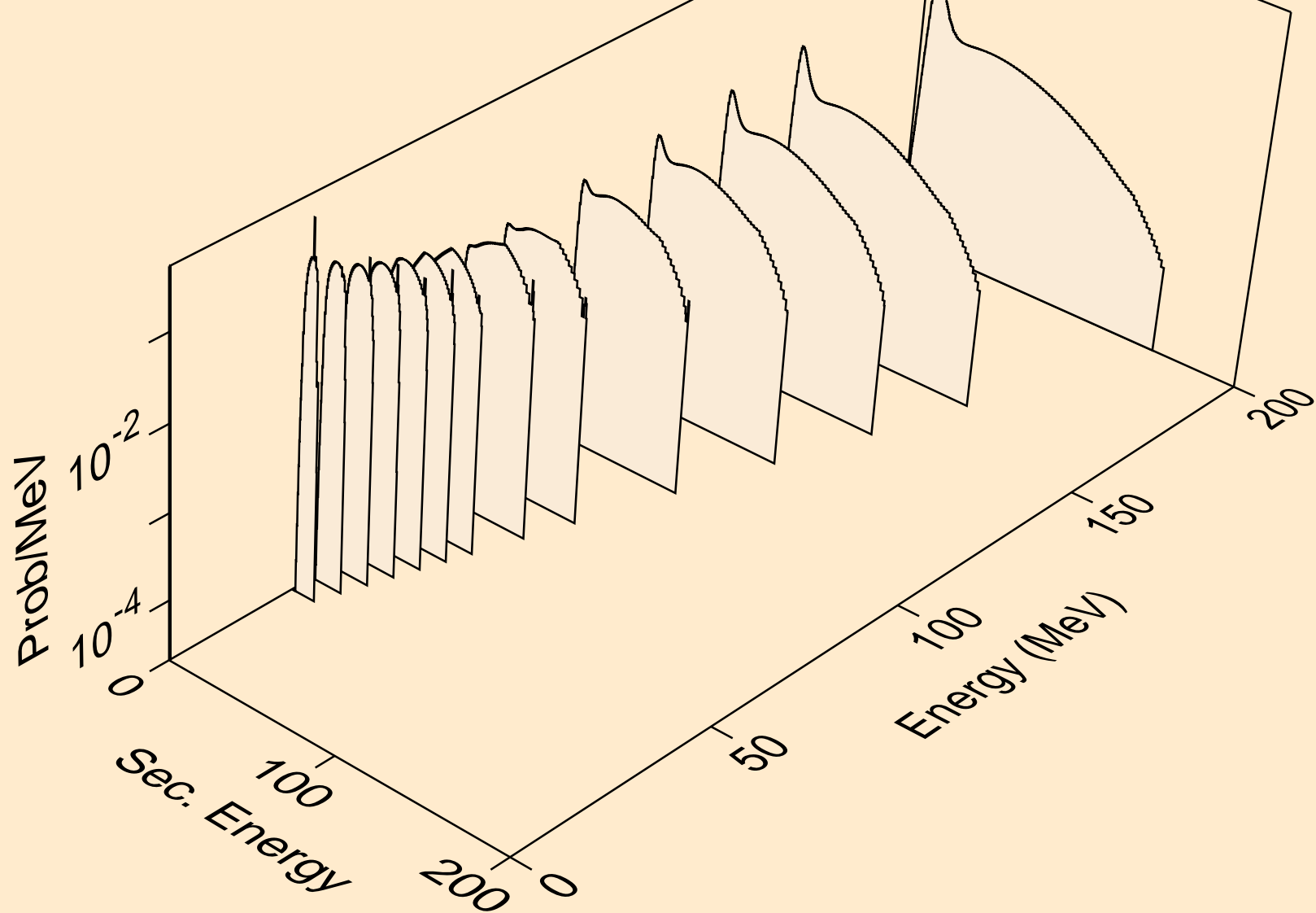

P029 PROTON ACER TENDL-2024 LIBRARY; T=0.K  
he3s from (p,n\*)he3

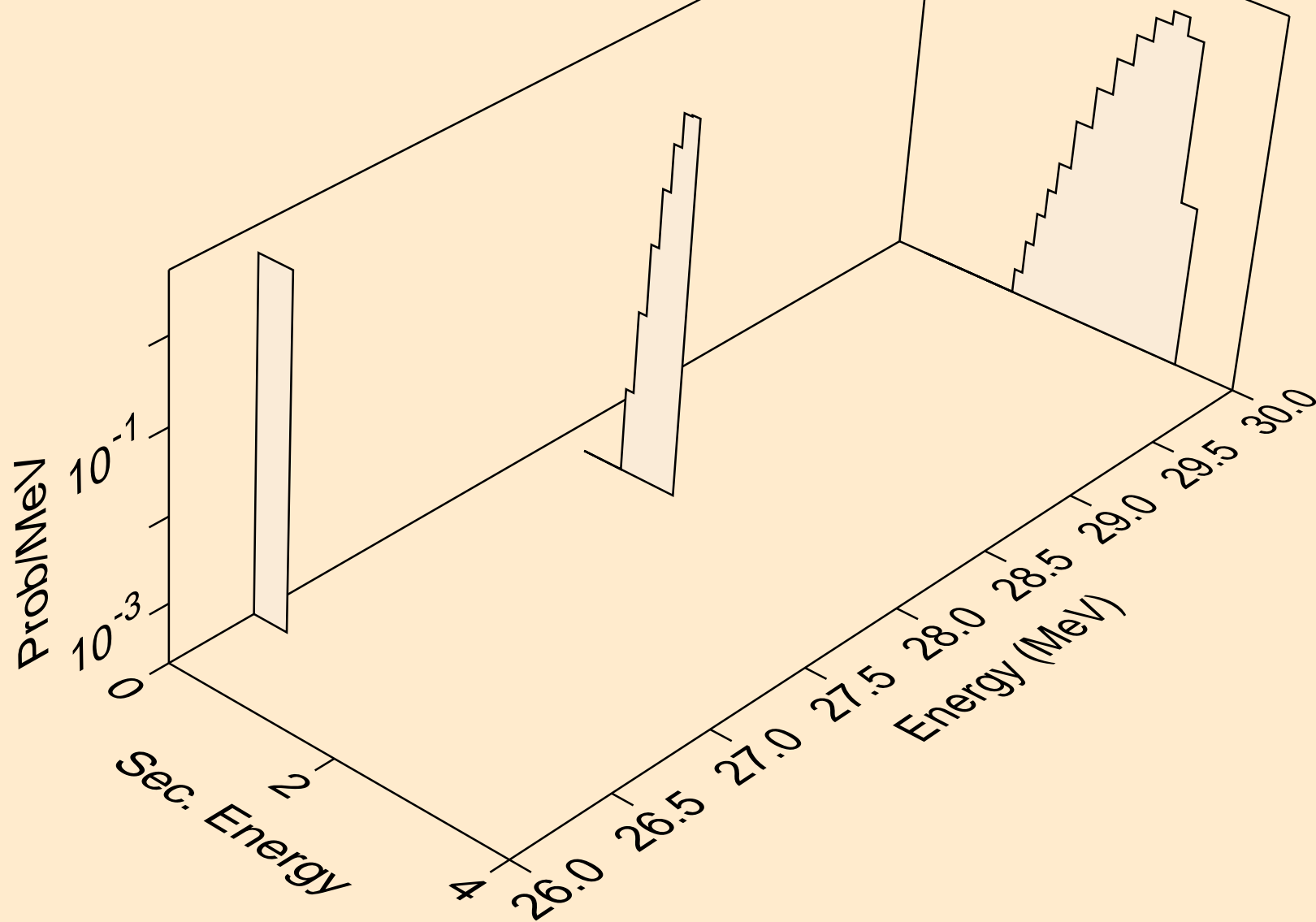

P029 PROTON ACER TENDL-2024 LIBRARY; T=0.K  
he3s from (p,he3)

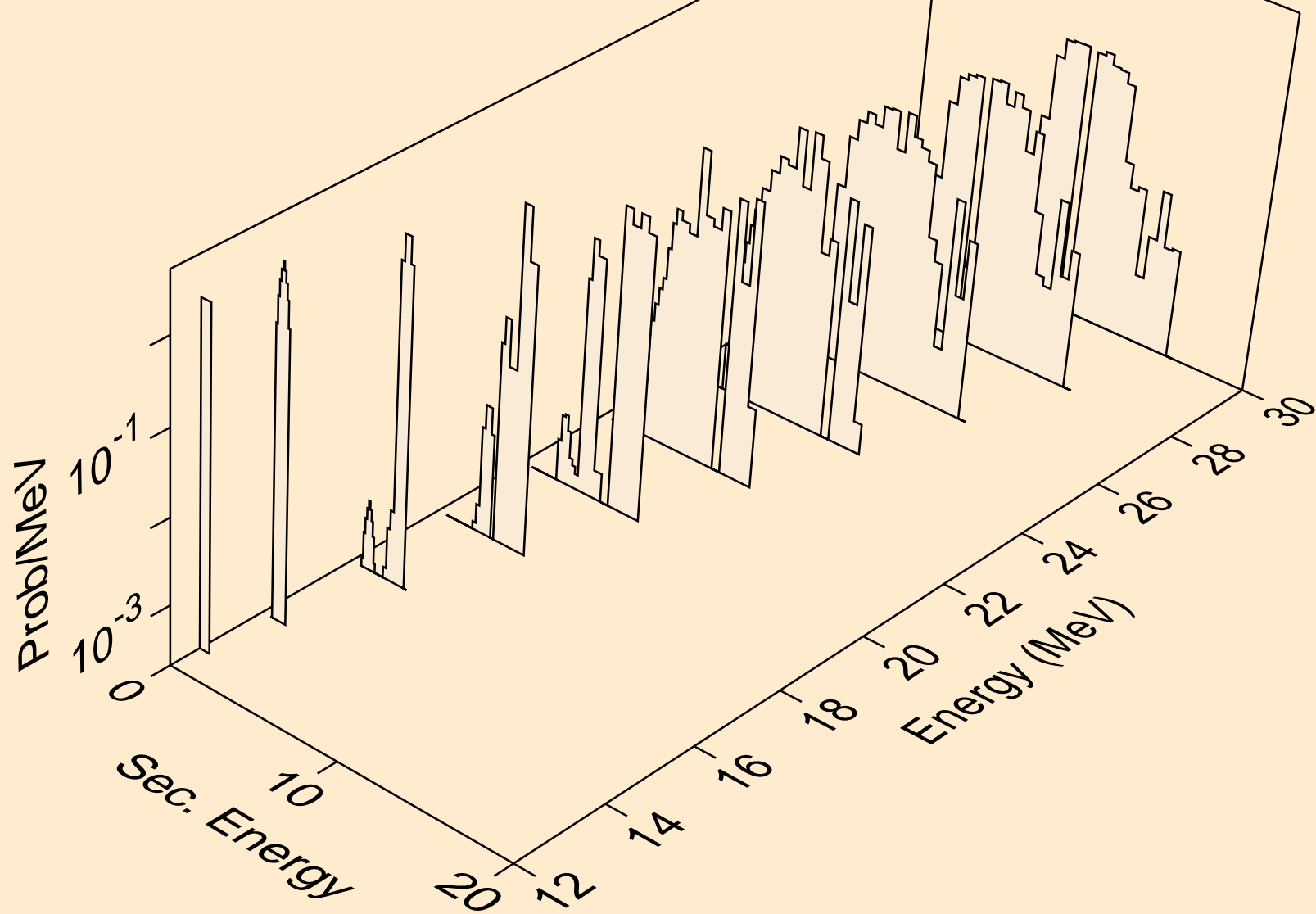

P029 PROTON ACER TENDL-2024 LIBRARY; T=0.K  
alphas from (p,x)

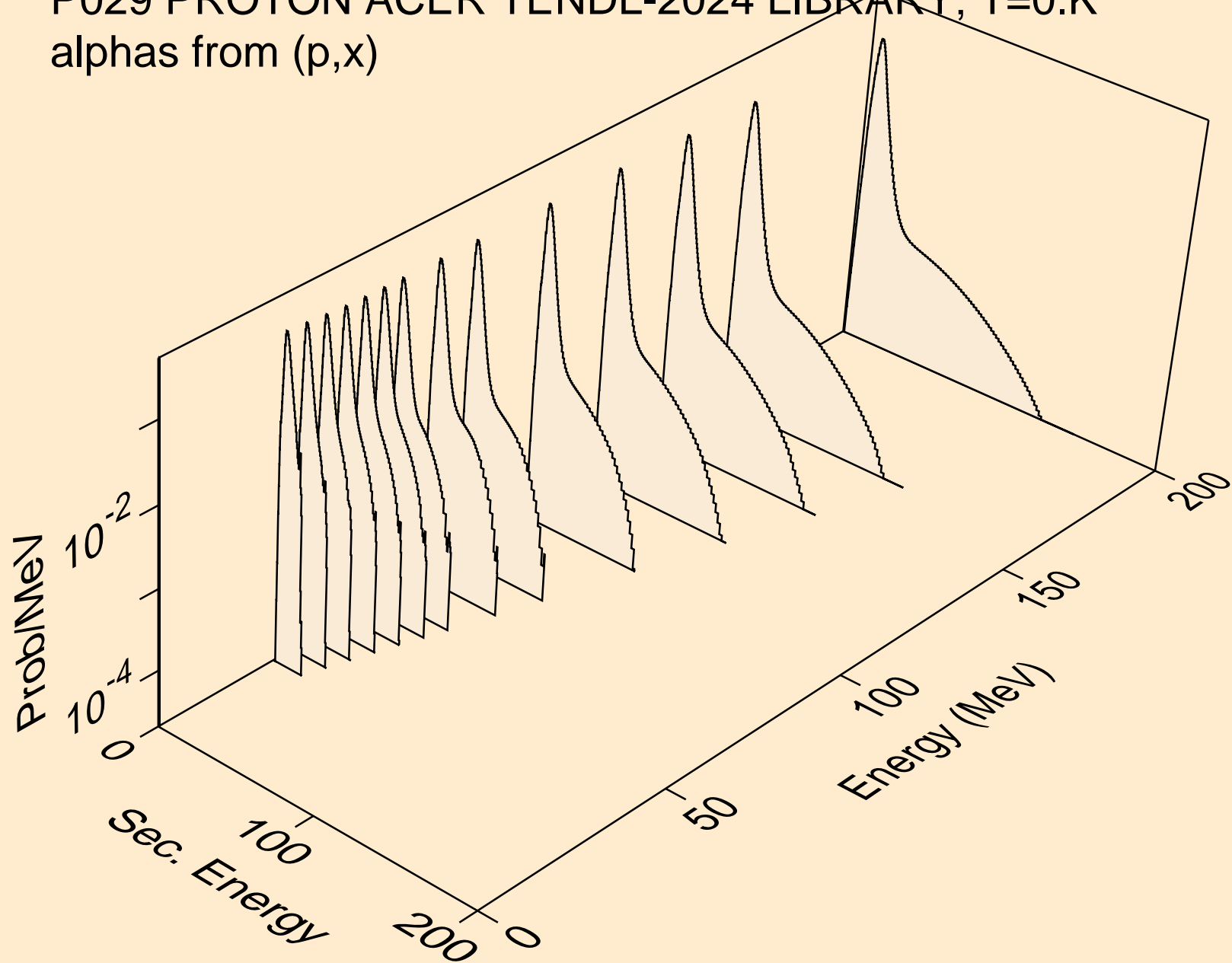

P029 PROTON ACER TENDL-2024 LIBRARY; T=0.K  
alphas from (p,n\*)a

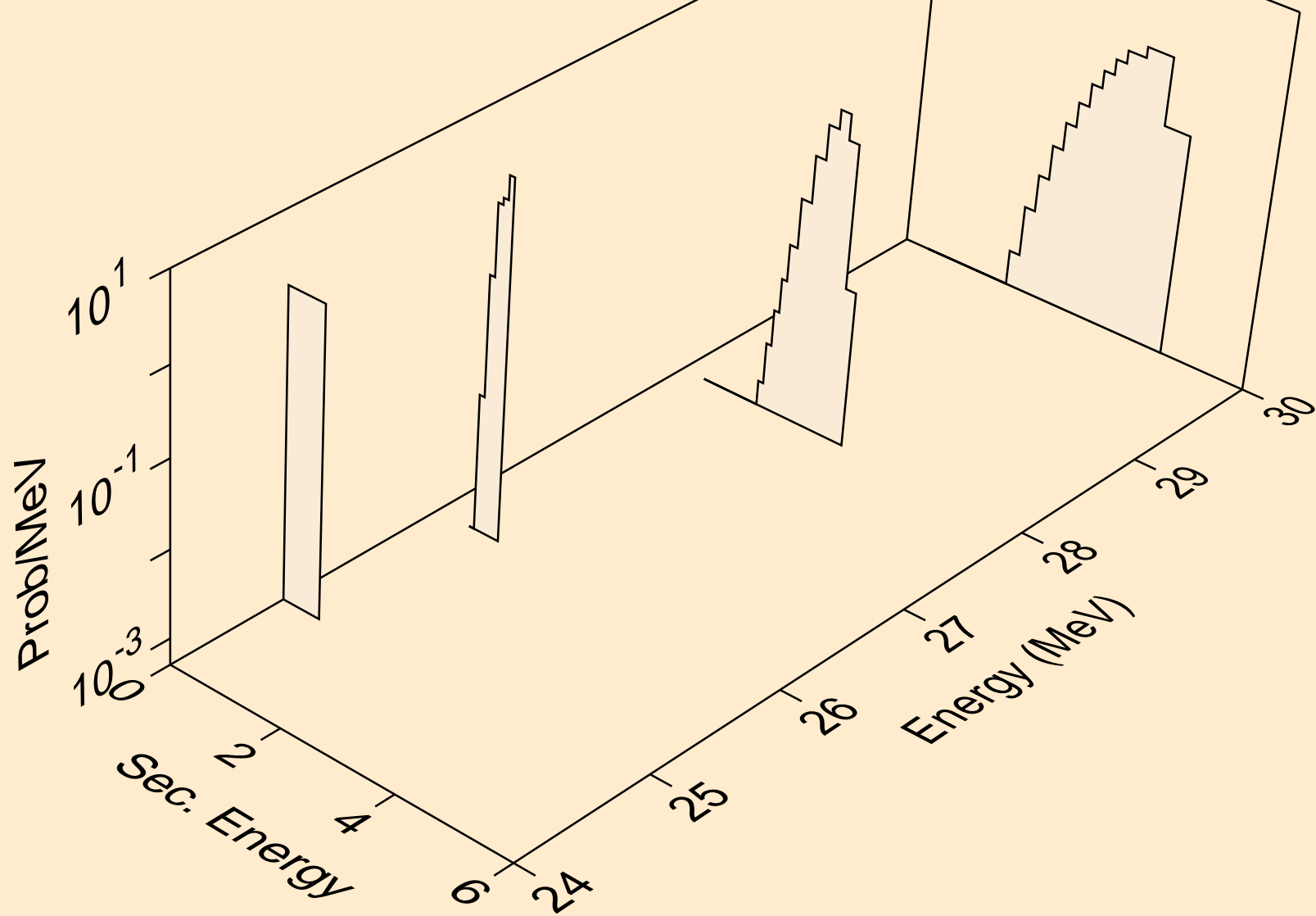

P029 PROTON ACER TENDL-2024 LIBRARY; T=0.K  
alphas from (p,a)

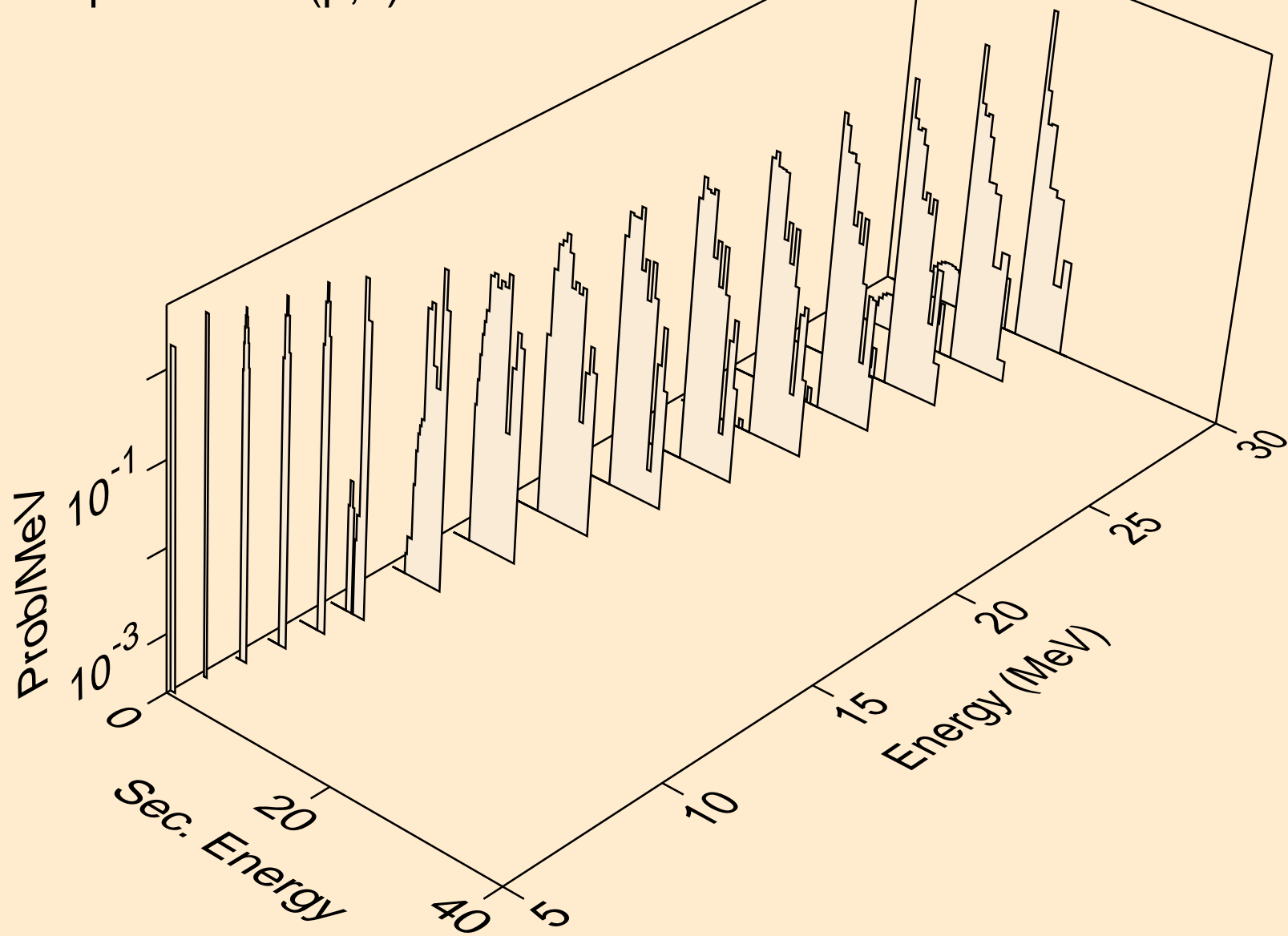

P029 PROTON ACER TENDL-2024 LIBRARY; T=0.K  
alphas from (p,2a)

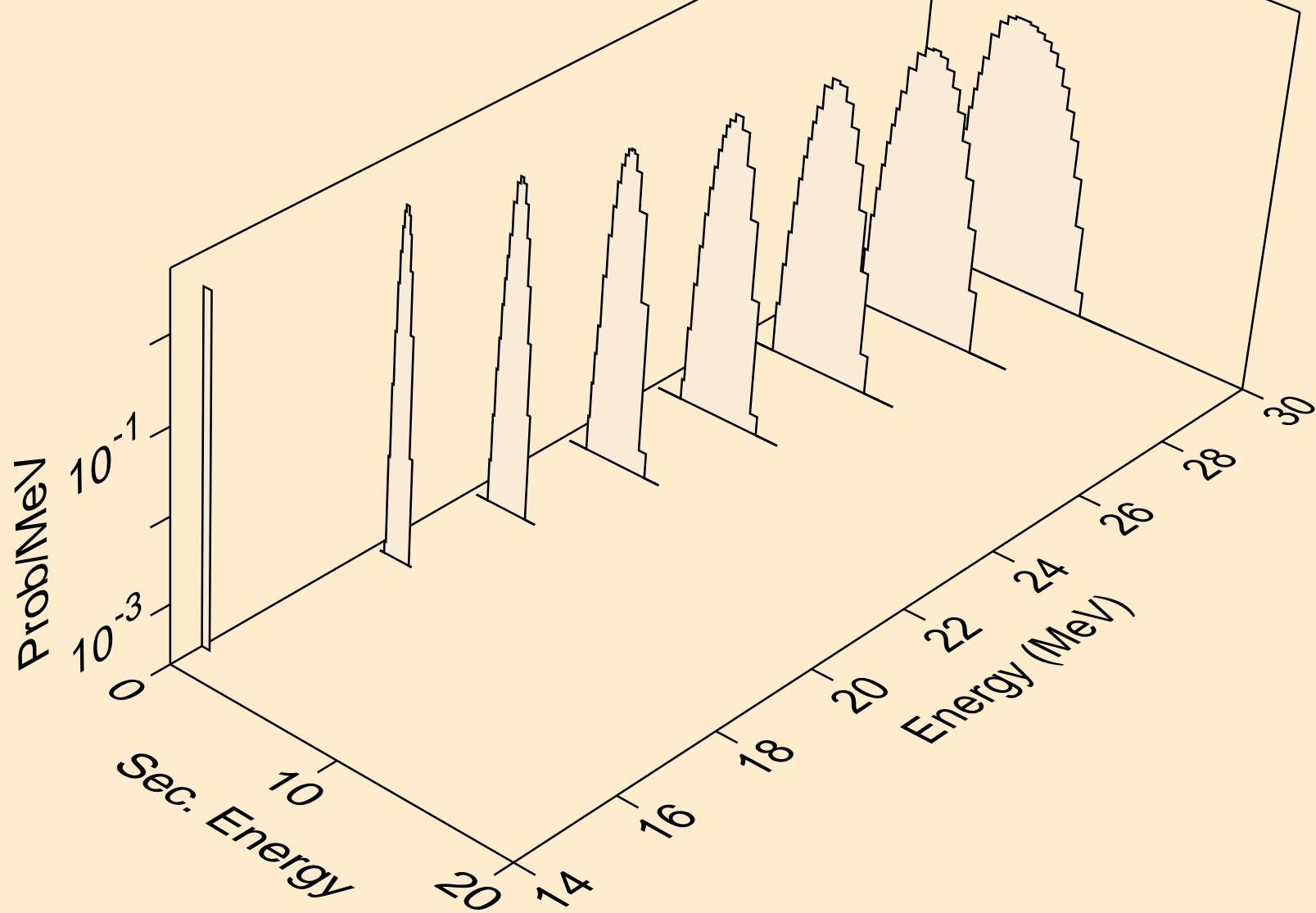

P029 PROTON ACER TENDL-2024 LIBRARY; T=0.K  
alphas from (p,pa)

