

PD101 PROTON ACER TENDL-2024 LIBRARY; T=0.K  
Principal cross sections

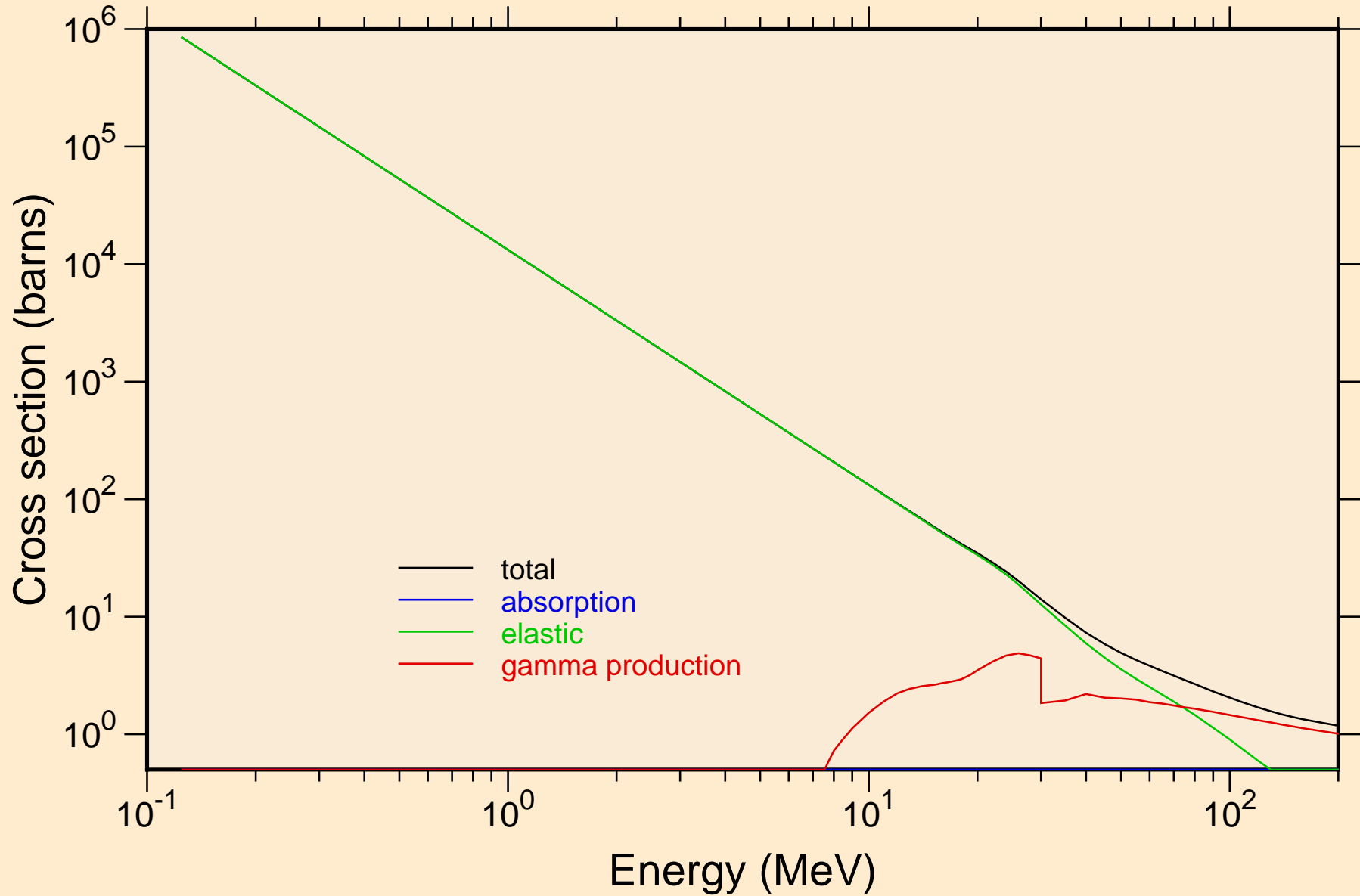

# PD101 PROTON ACER TENDL-2024 LIBRARY; T=0.K

## Heating

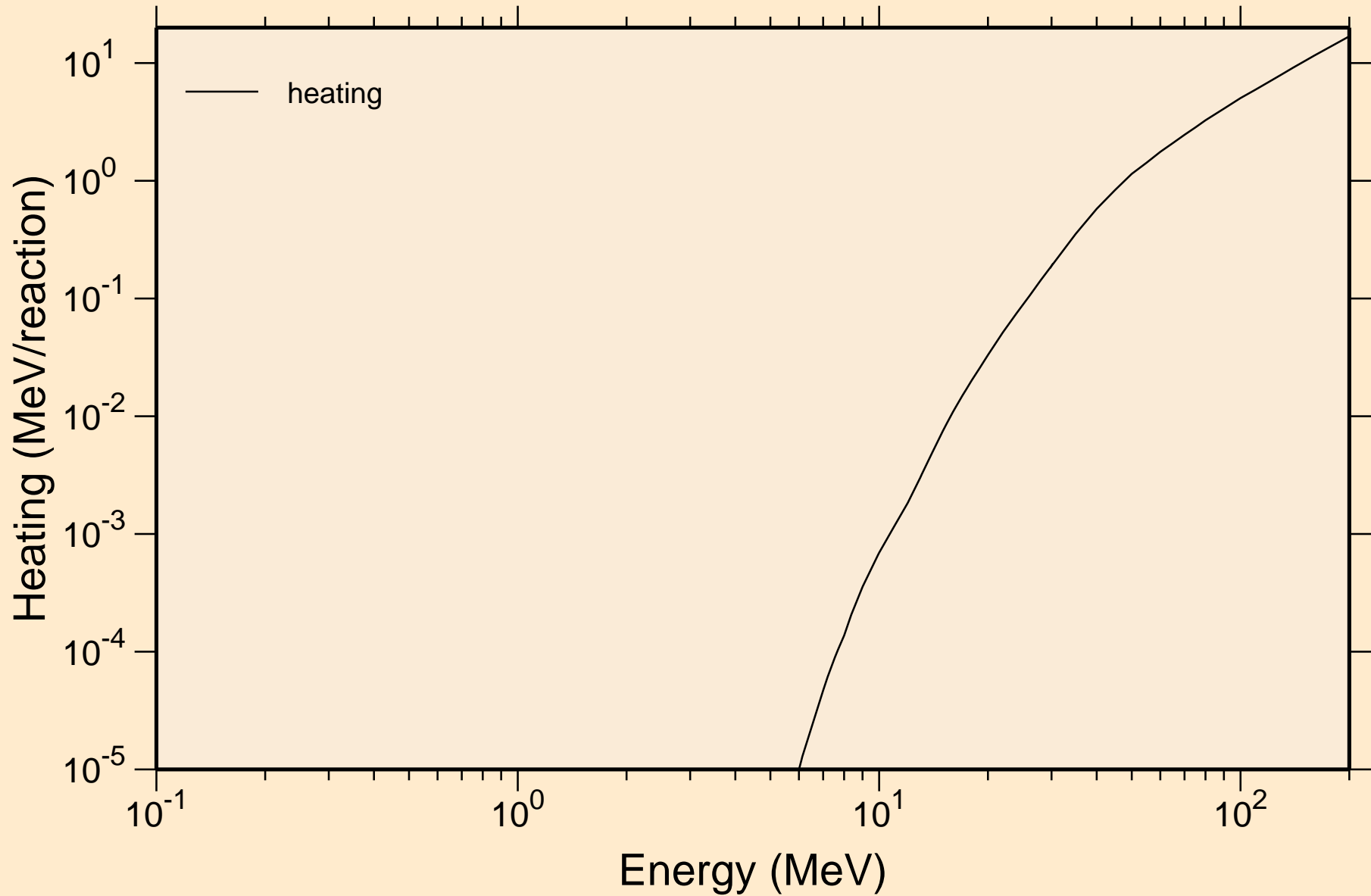

# PD101 PROTON ACER TENDL-2024 LIBRARY; T=0.K

## Principal cross sections

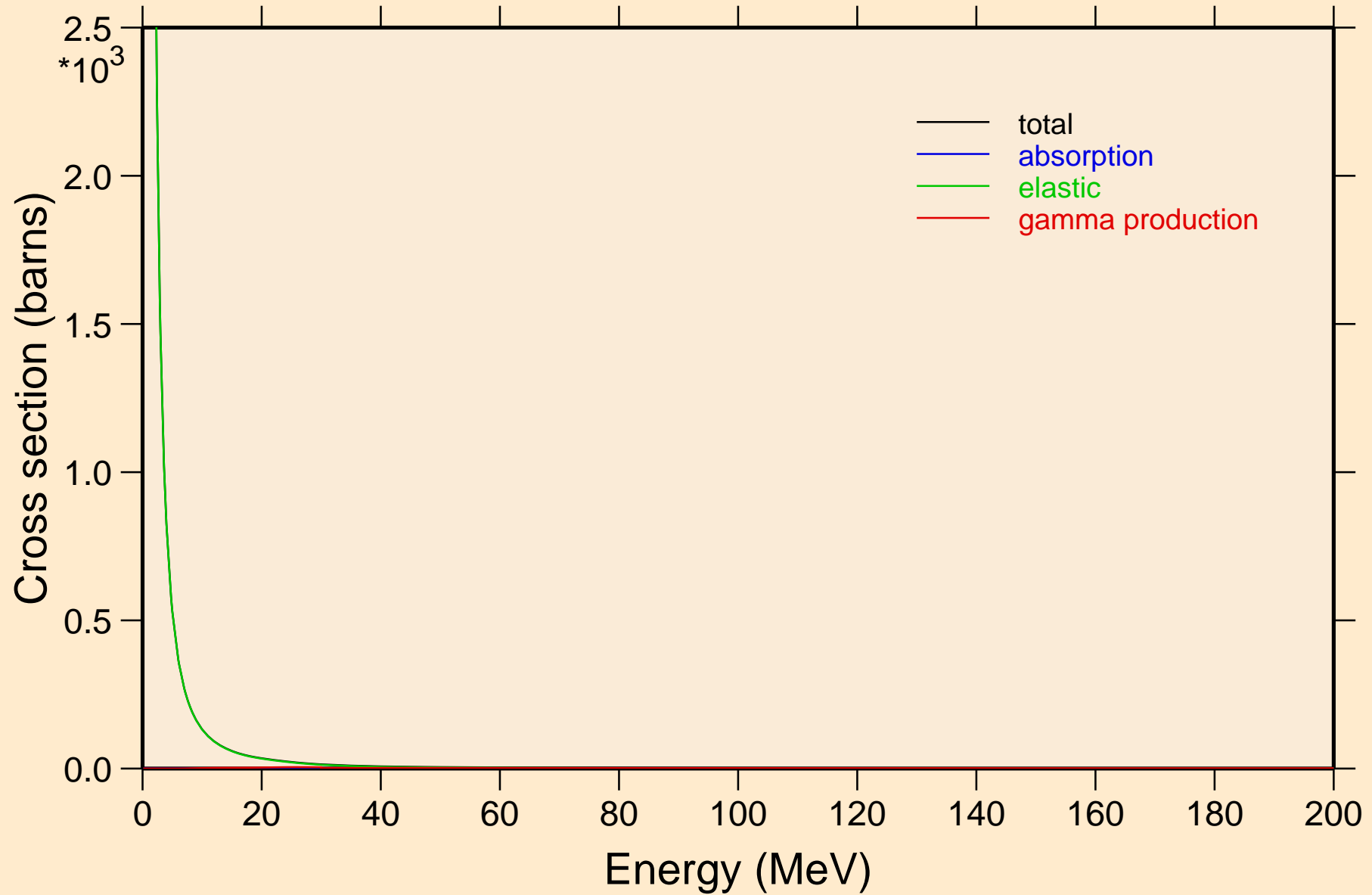

PD101 PROTON ACER TENDL-2024 LIBRARY; T=0.K

Heating

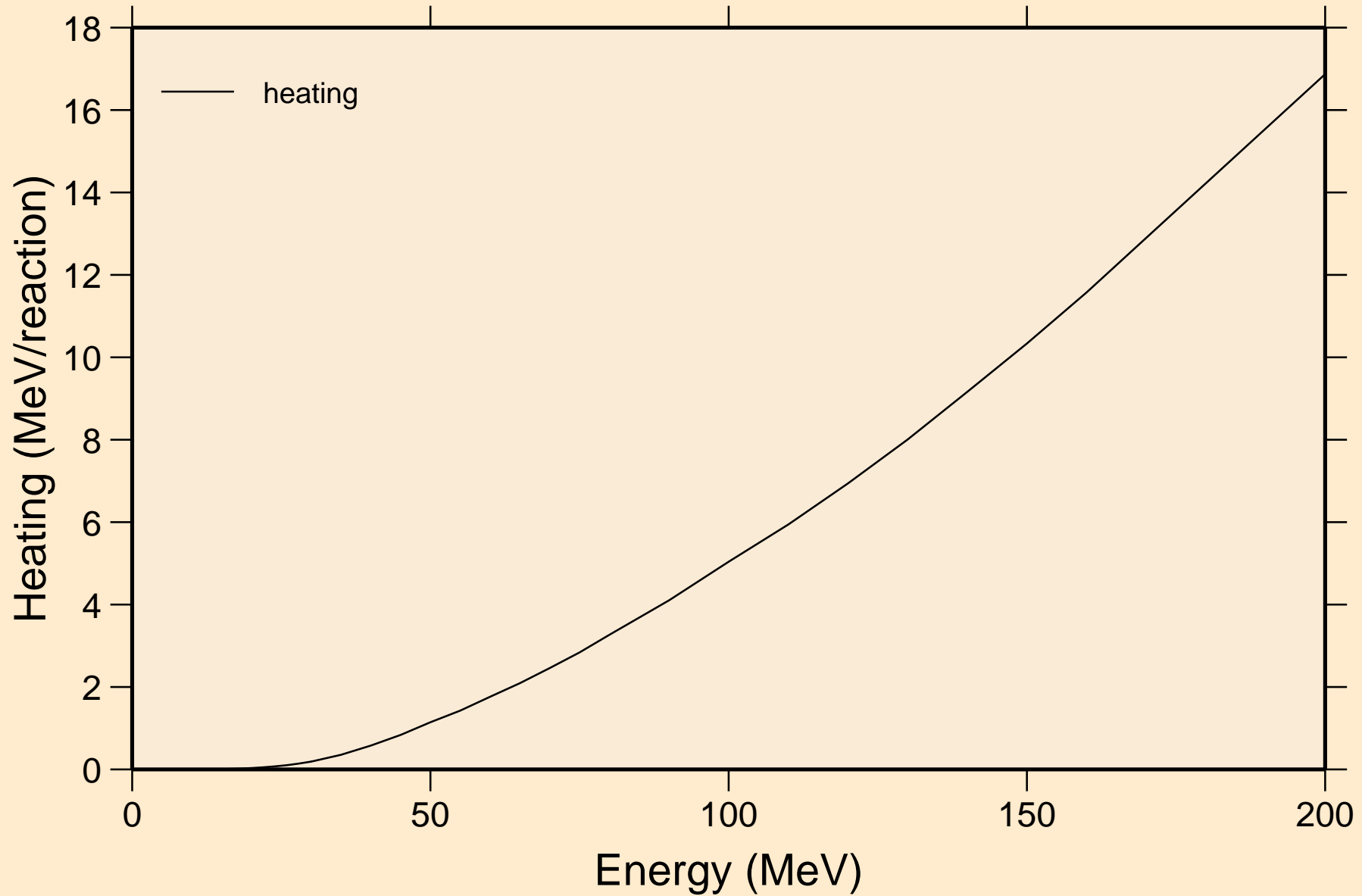

PD101 PROTON ACER TENDL-2024 LIBRARY; T=0.K  
Threshold reactions

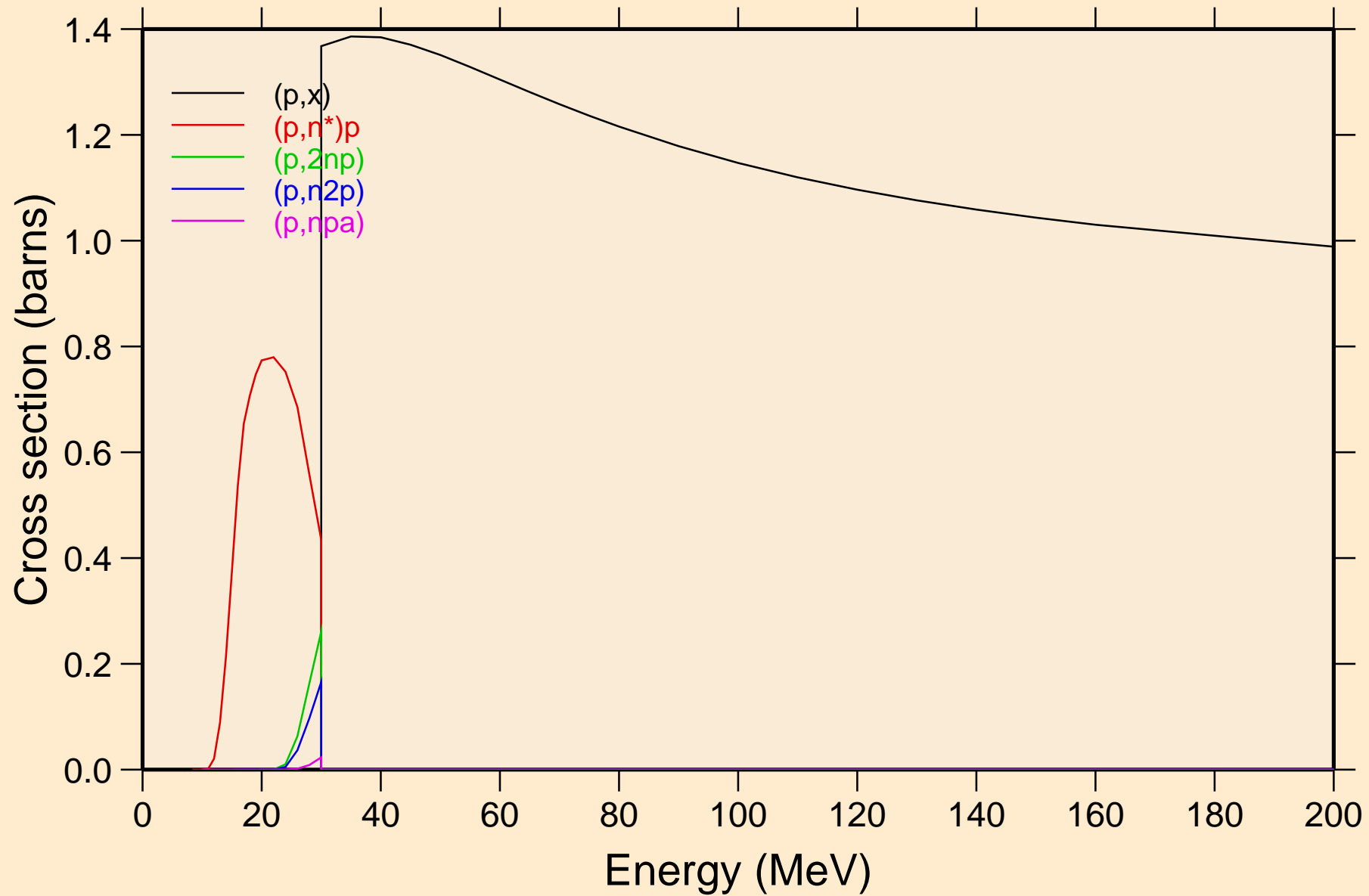

PD101 PROTON ACER TENDL-2024 LIBRARY; T=0.K  
Threshold reactions

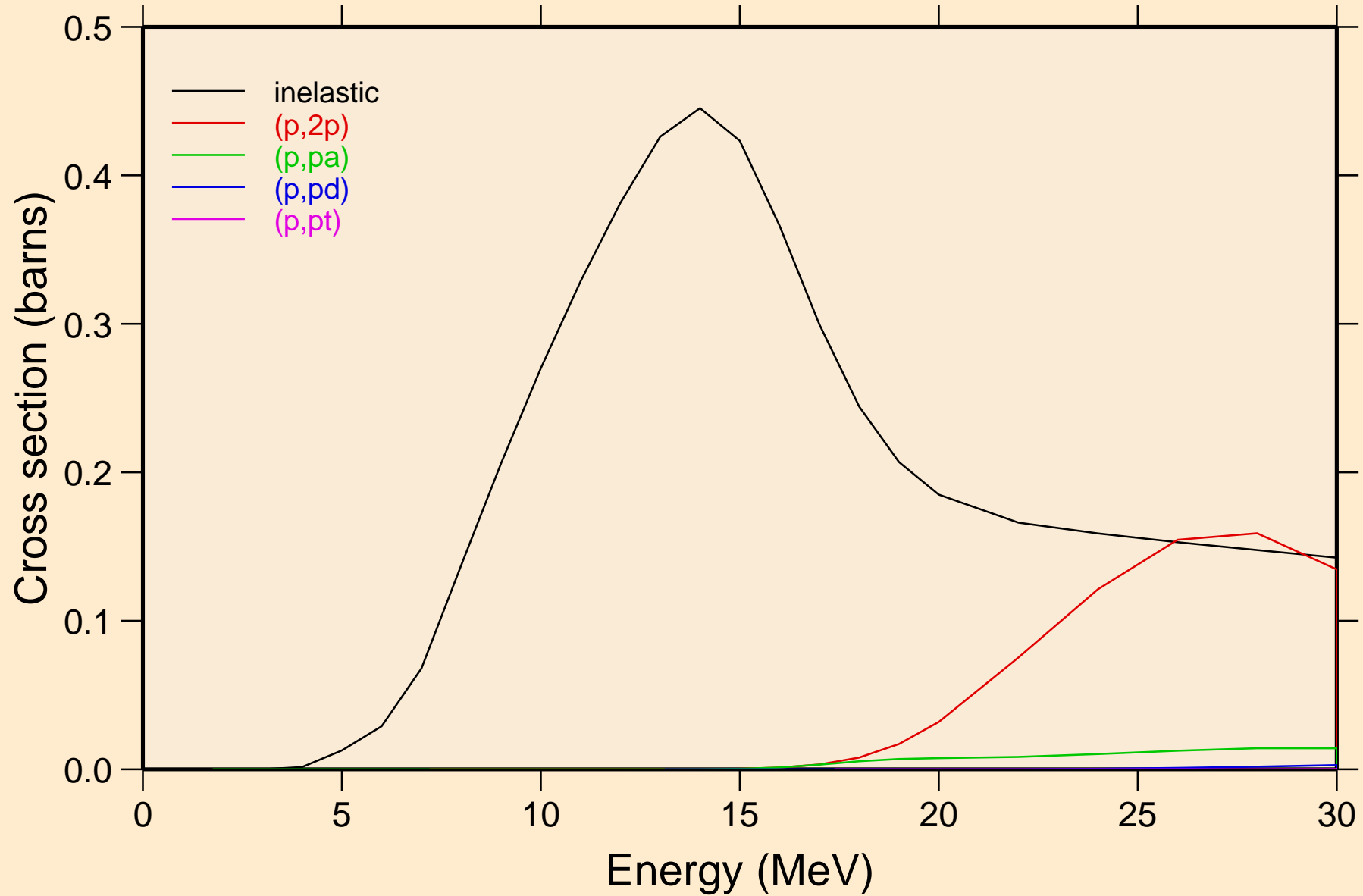

PD101 PROTON ACER TENDL-2024 LIBRARY; T=0.K  
Threshold reactions

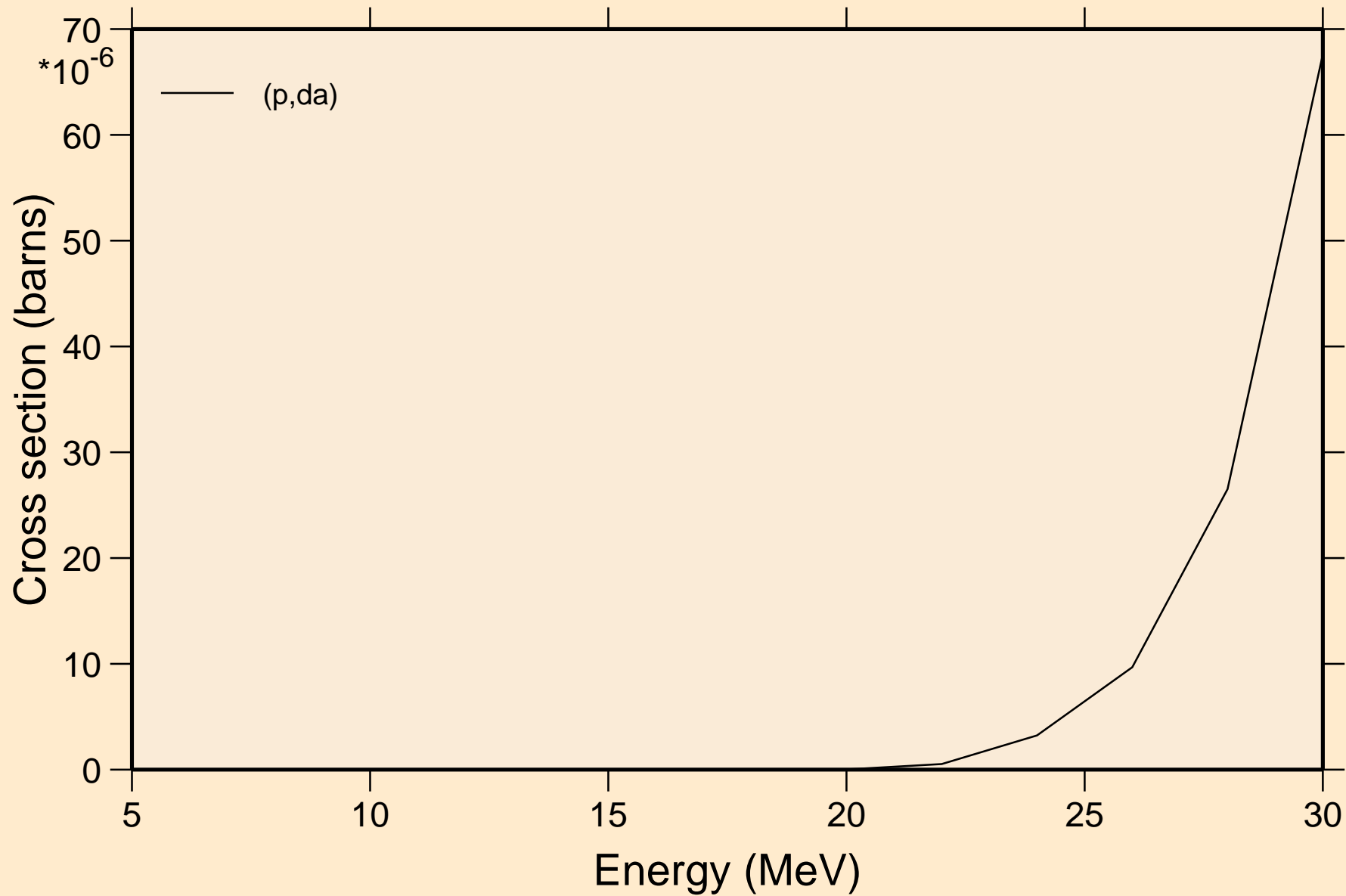

PD101 PROTON ACER TENDL-2024 LIBRARY; T=0.K  
angular distribution for elastic

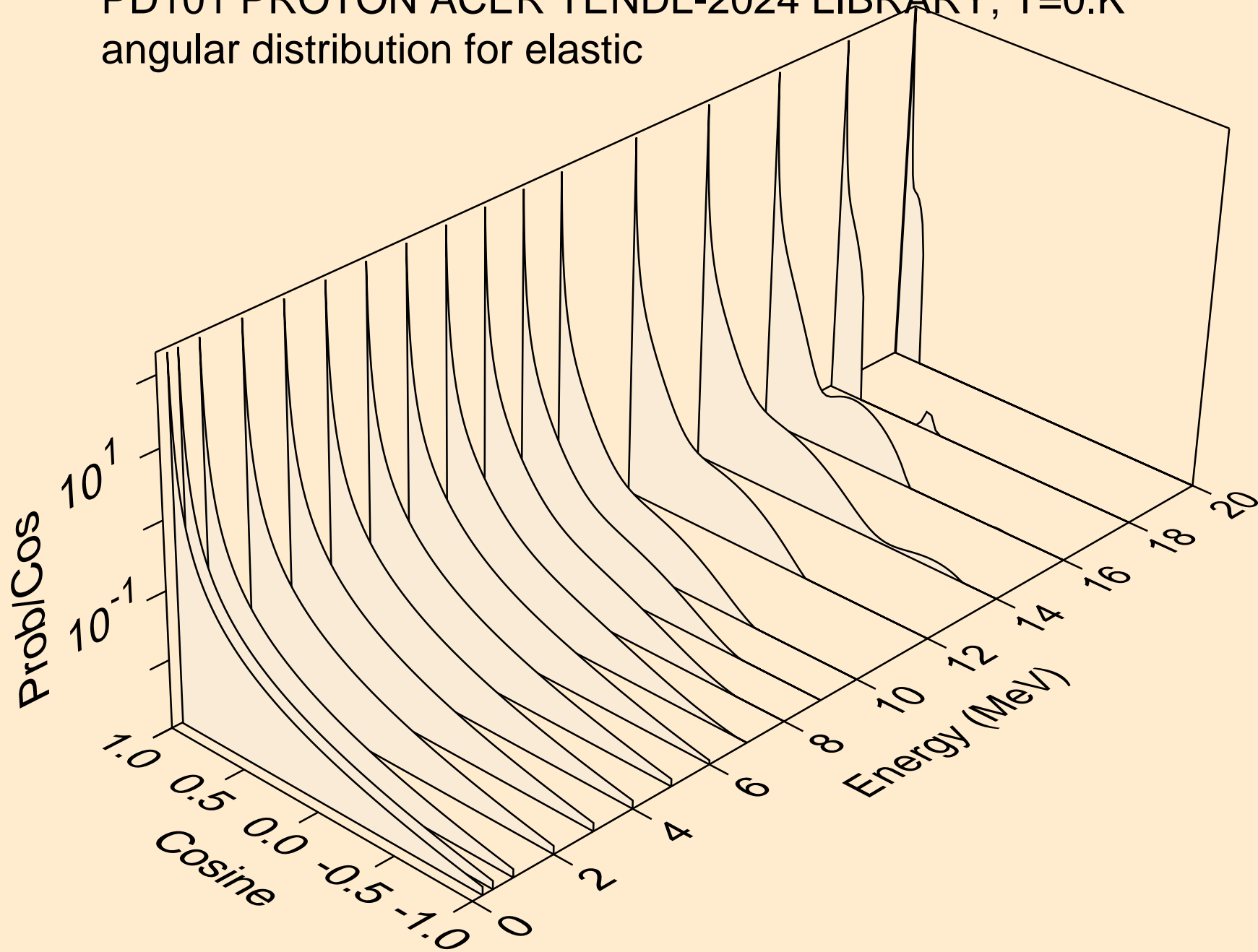

PD101 PROTON ACER TENDL-2024 LIBRARY; T=0.K  
angular distribution for elastic

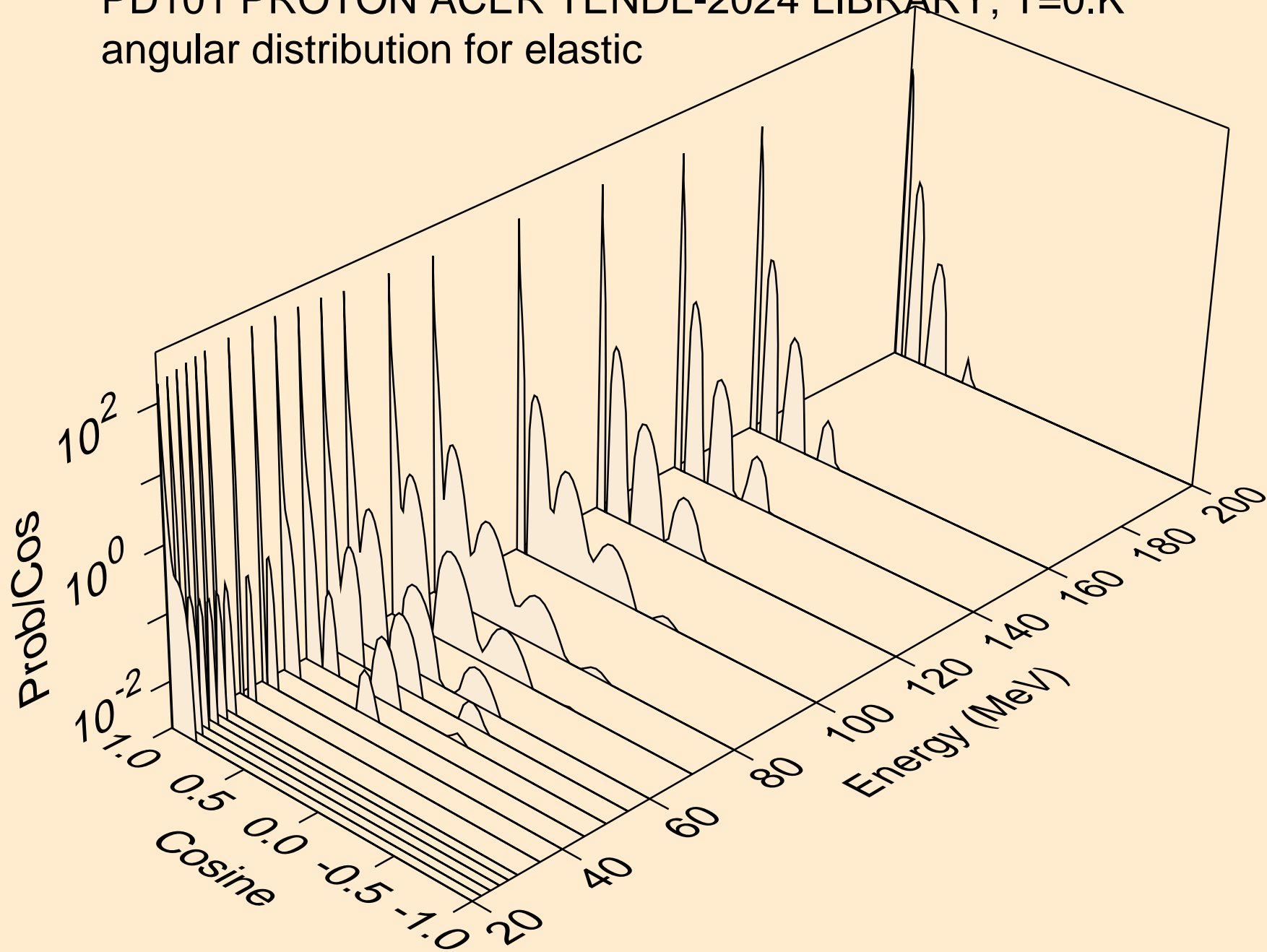

PD101 PROTON ACER TENDL-2024 LIBRARY; T=0.K  
Proton emission for (p,x)

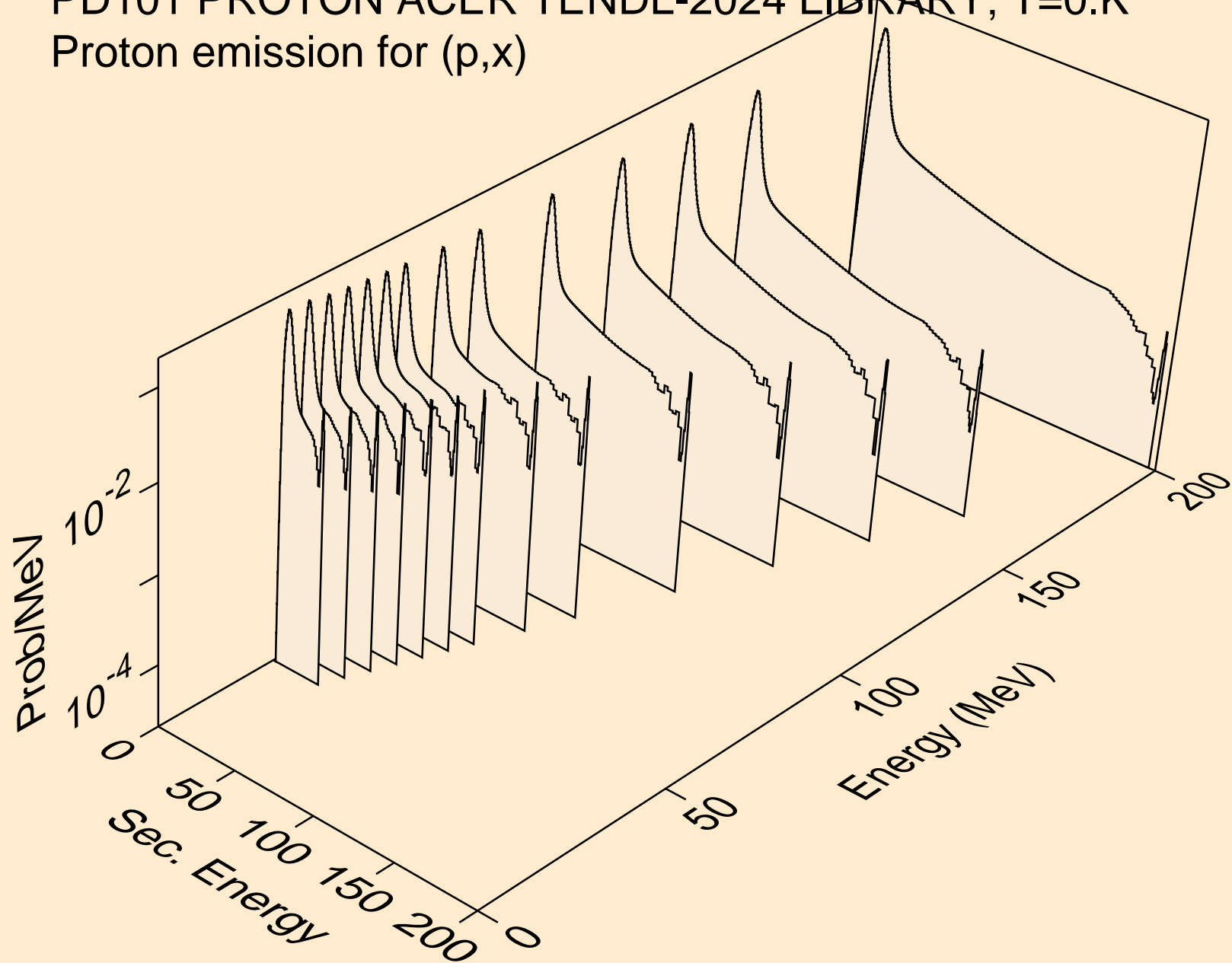

PD101 PROTON ACER TENDL-2024 LIBRARY; T=0.K  
Proton emission for (p,n\*)p

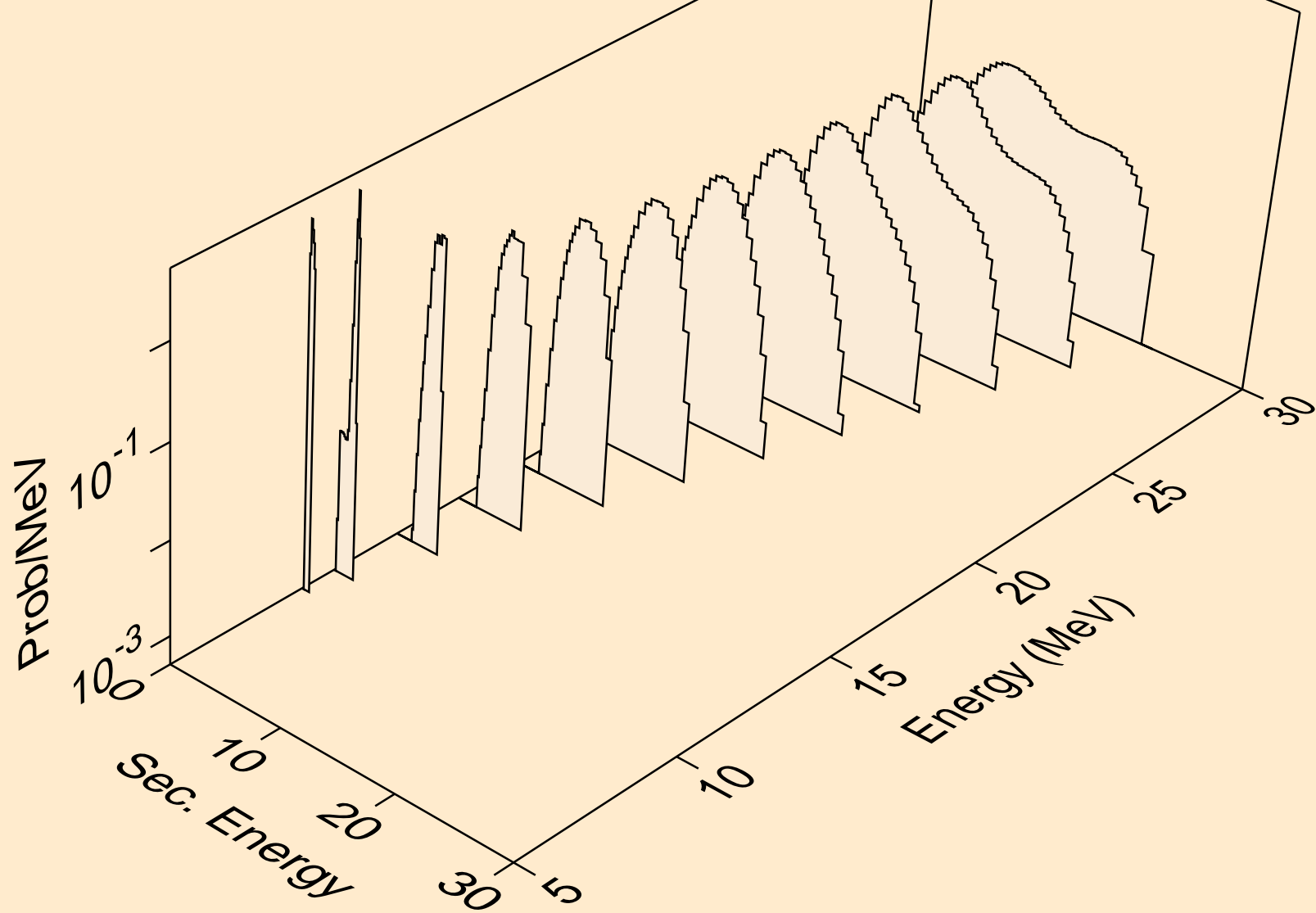

PD101 PROTON ACER TENDL-2024 LIBRARY; T=0.K  
Proton emission for (p,2np)

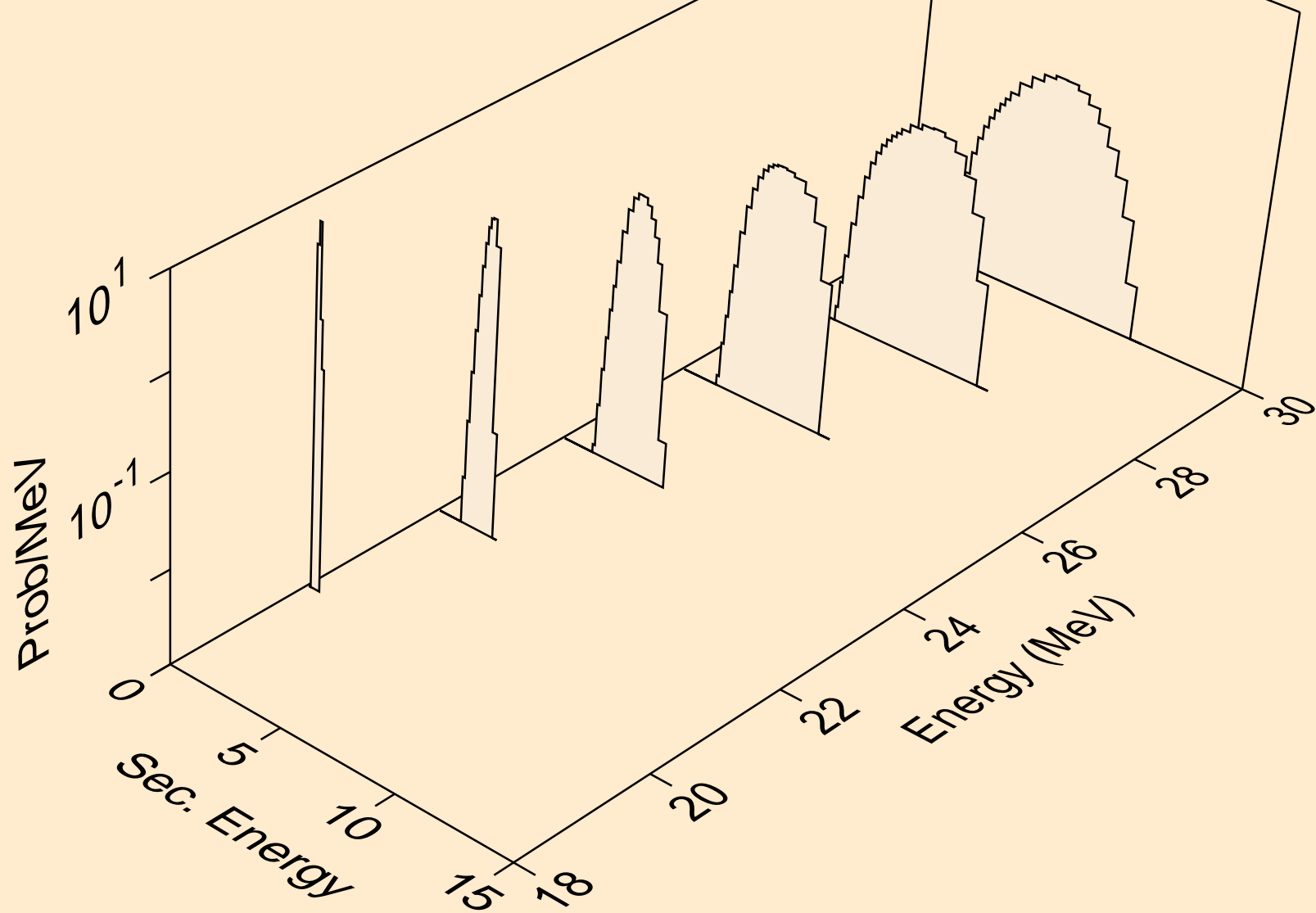

PD101 PROTON ACER TENDL-2024 LIBRARY; T=0.K  
Proton emission for (p,n2p)

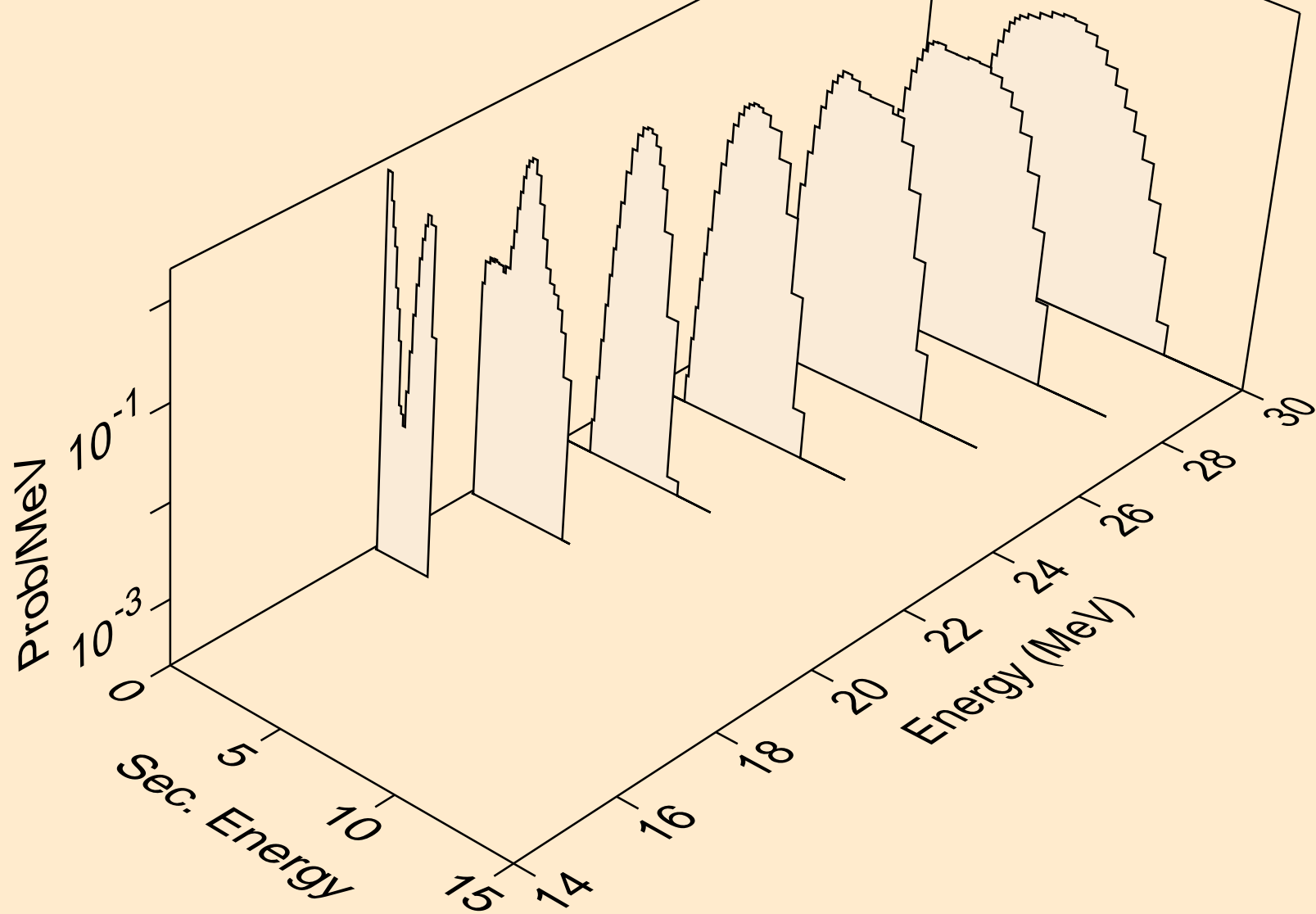

PD101 PROTON ACER TENDL-2024 LIBRARY; T=0.K  
Proton emission for (p,npa)

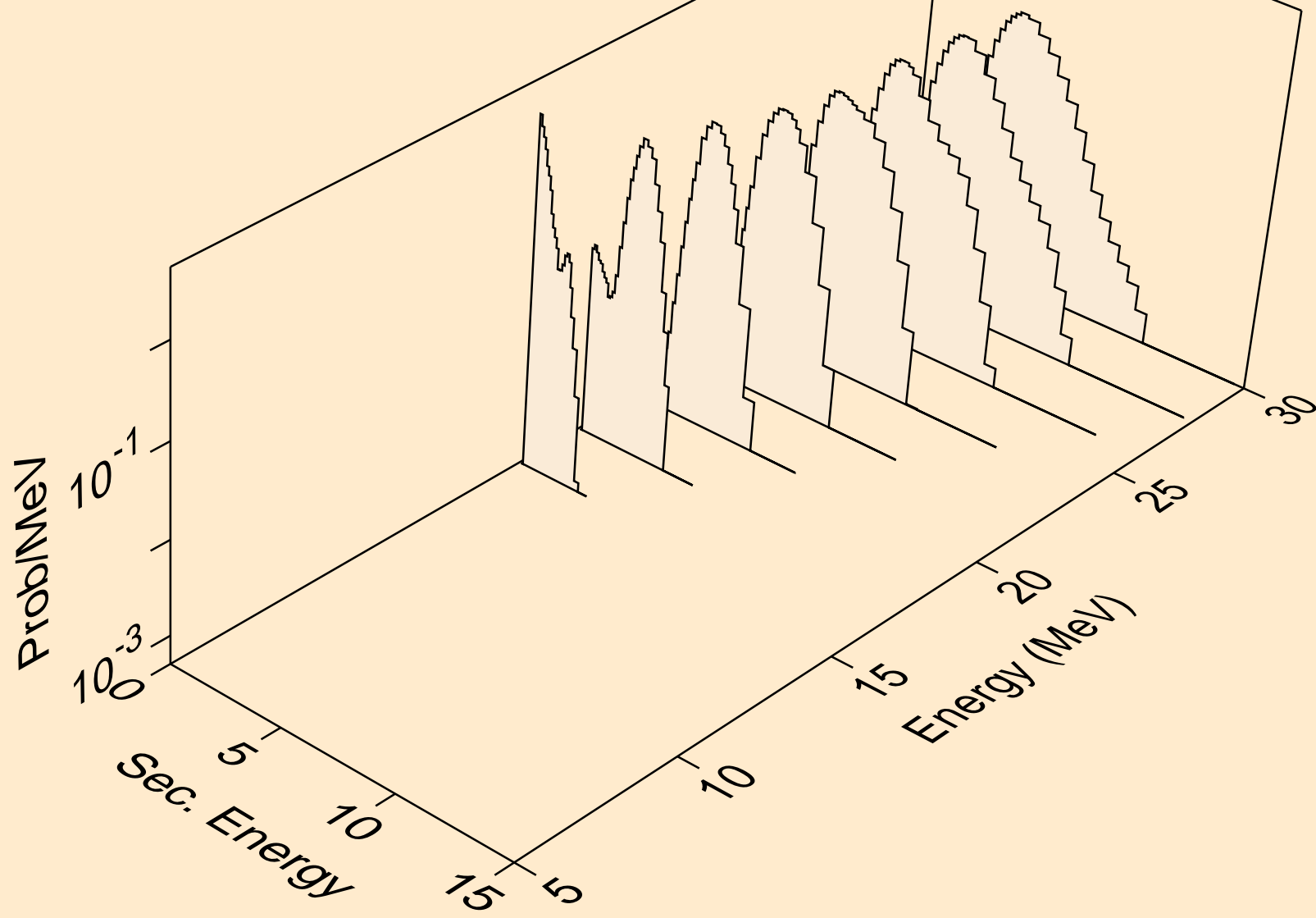

PD101 PROTON ACER TENDL-2024 LIBRARY; T=0.K  
Proton emission for inelastic

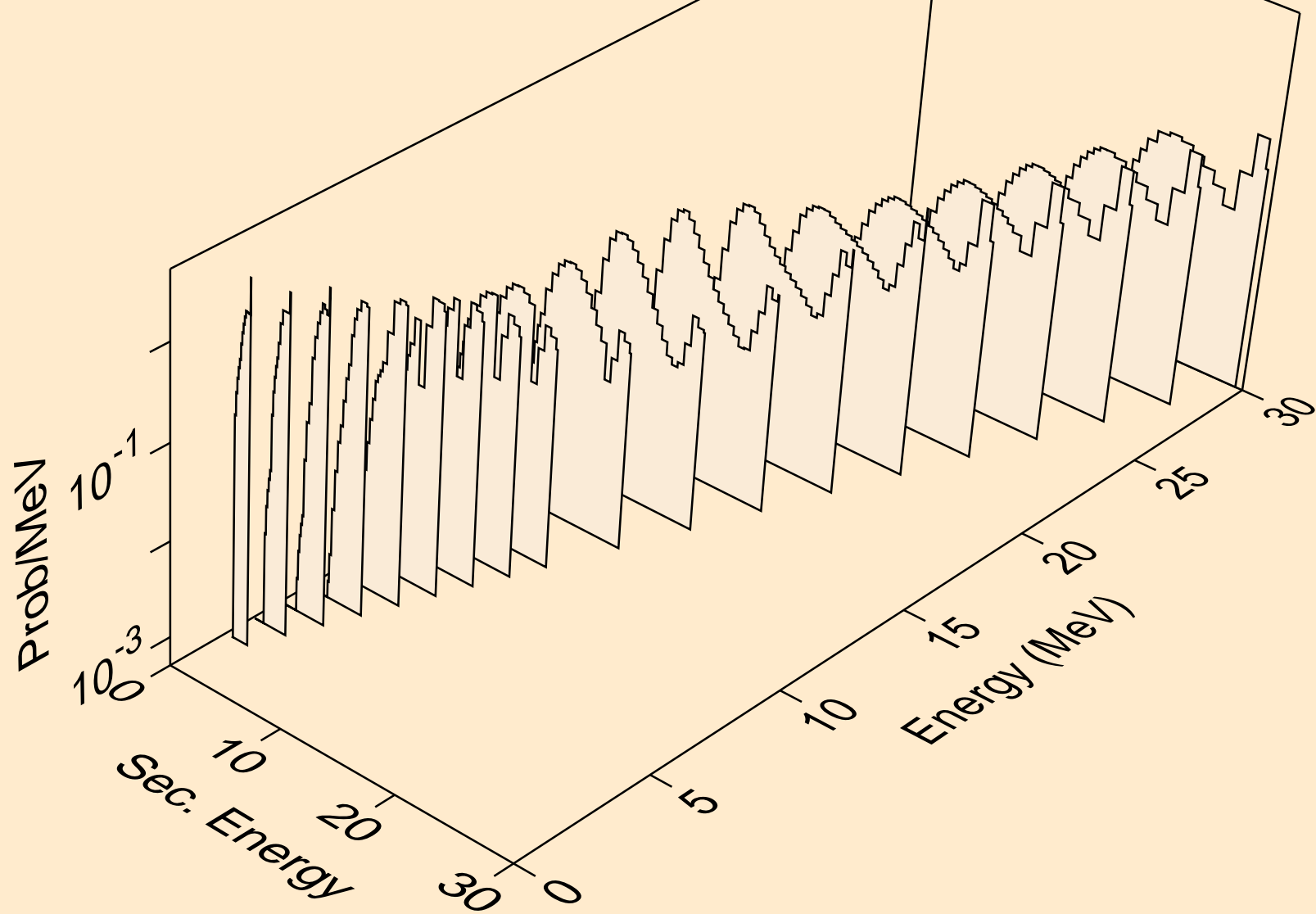

PD101 PROTON ACER TENDL-2024 LIBRARY; T=0.K  
Proton emission for (p,2p)

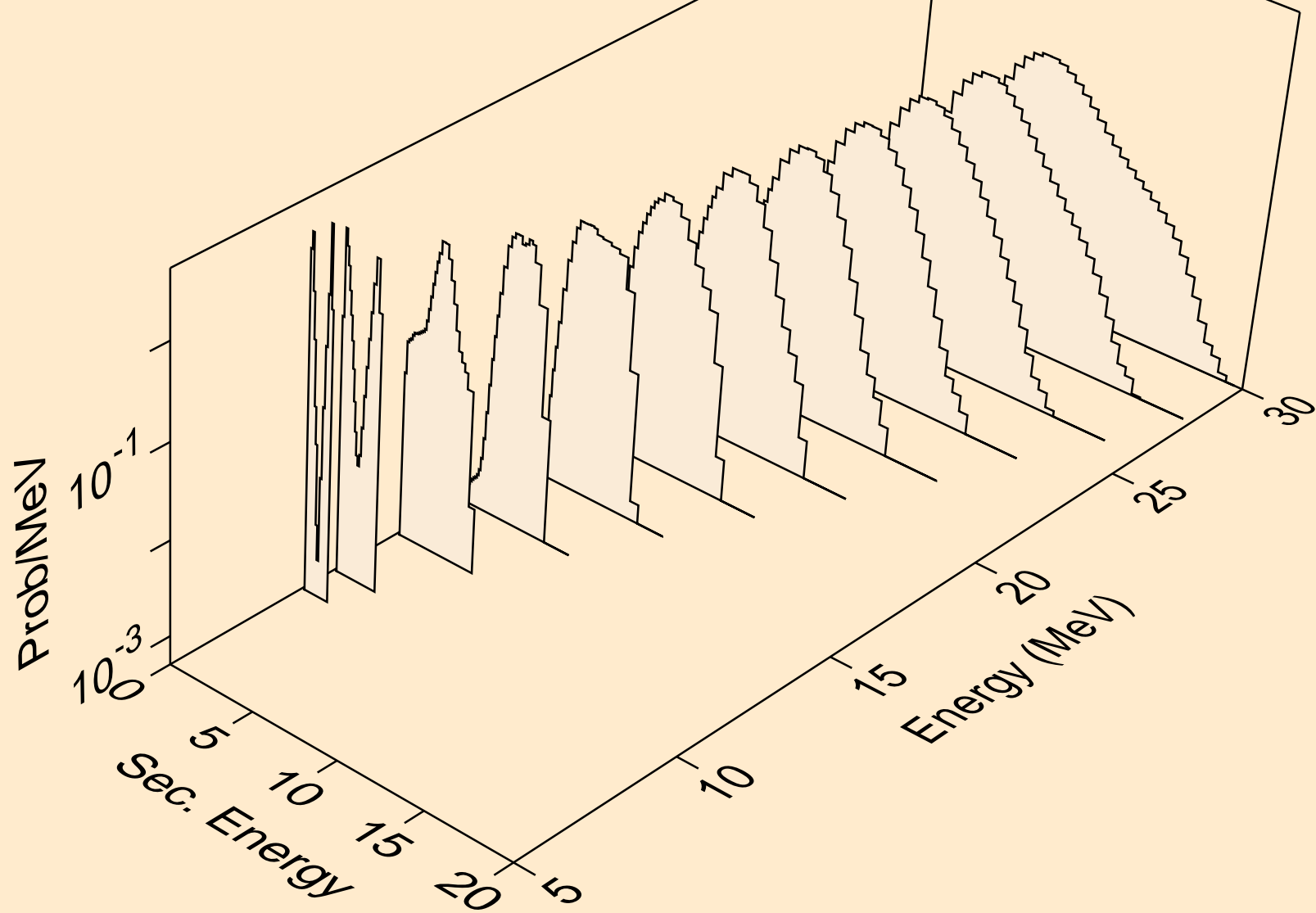

PD101 PROTON ACER TENDL-2024 LIBRARY; T=0.K  
Proton emission for (p,pa)

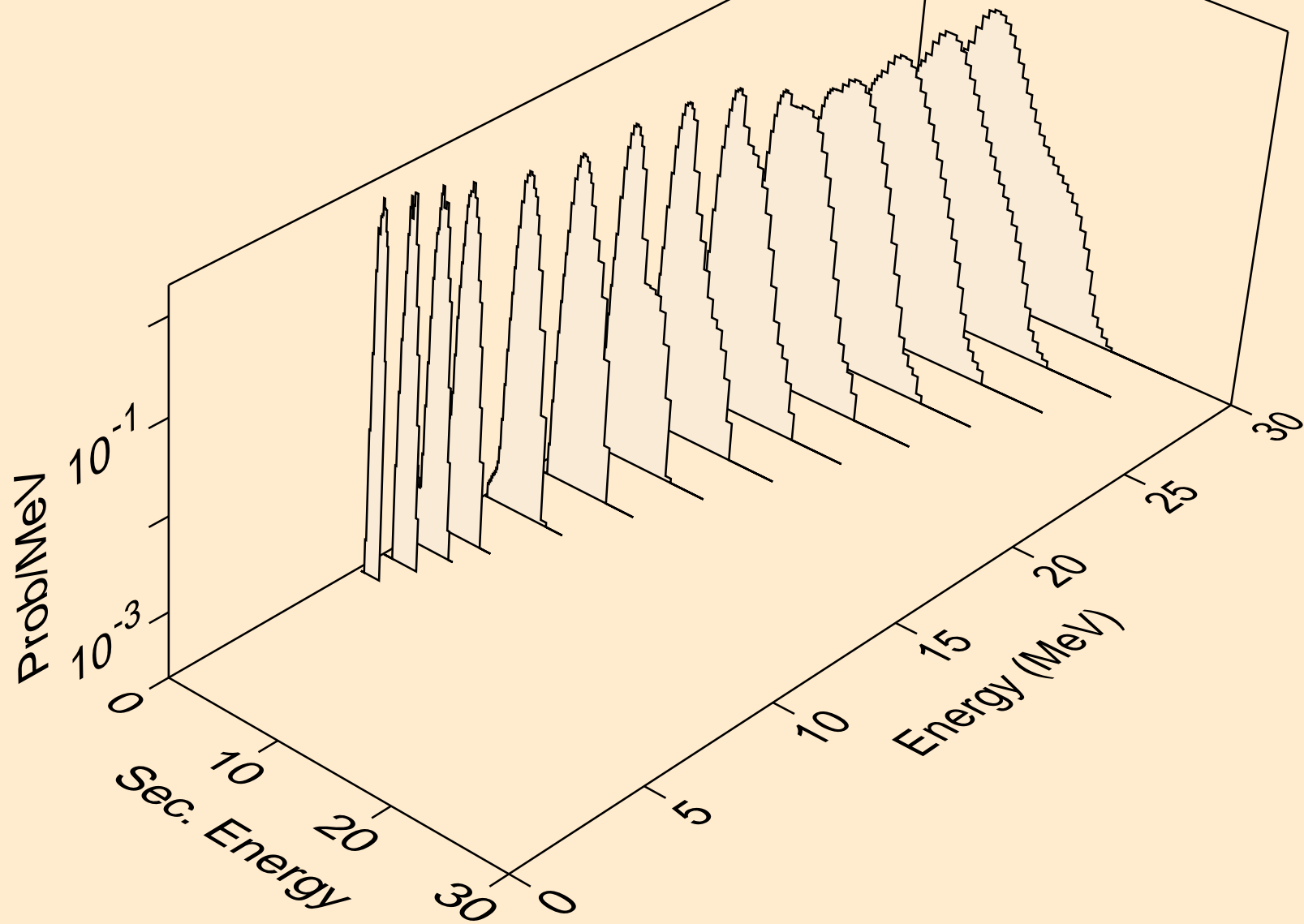

PD101 PROTON ACER TENDL-2024 LIBRARY; T=0.K  
Proton emission for (p,pd)

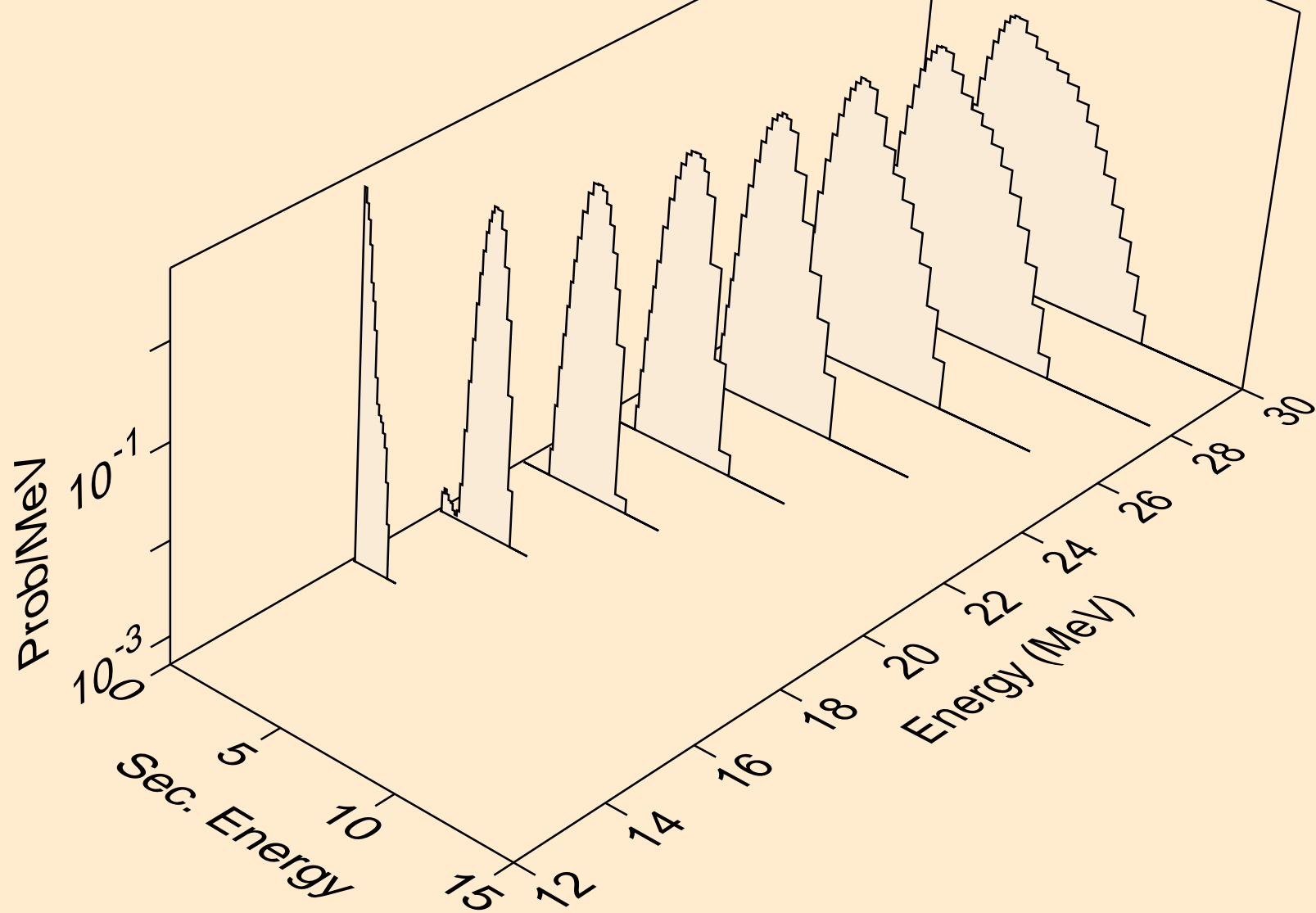

PD101 PROTON ACER TENDL-2024 LIBRARY; T=0.K  
Proton emission for (p,pt)

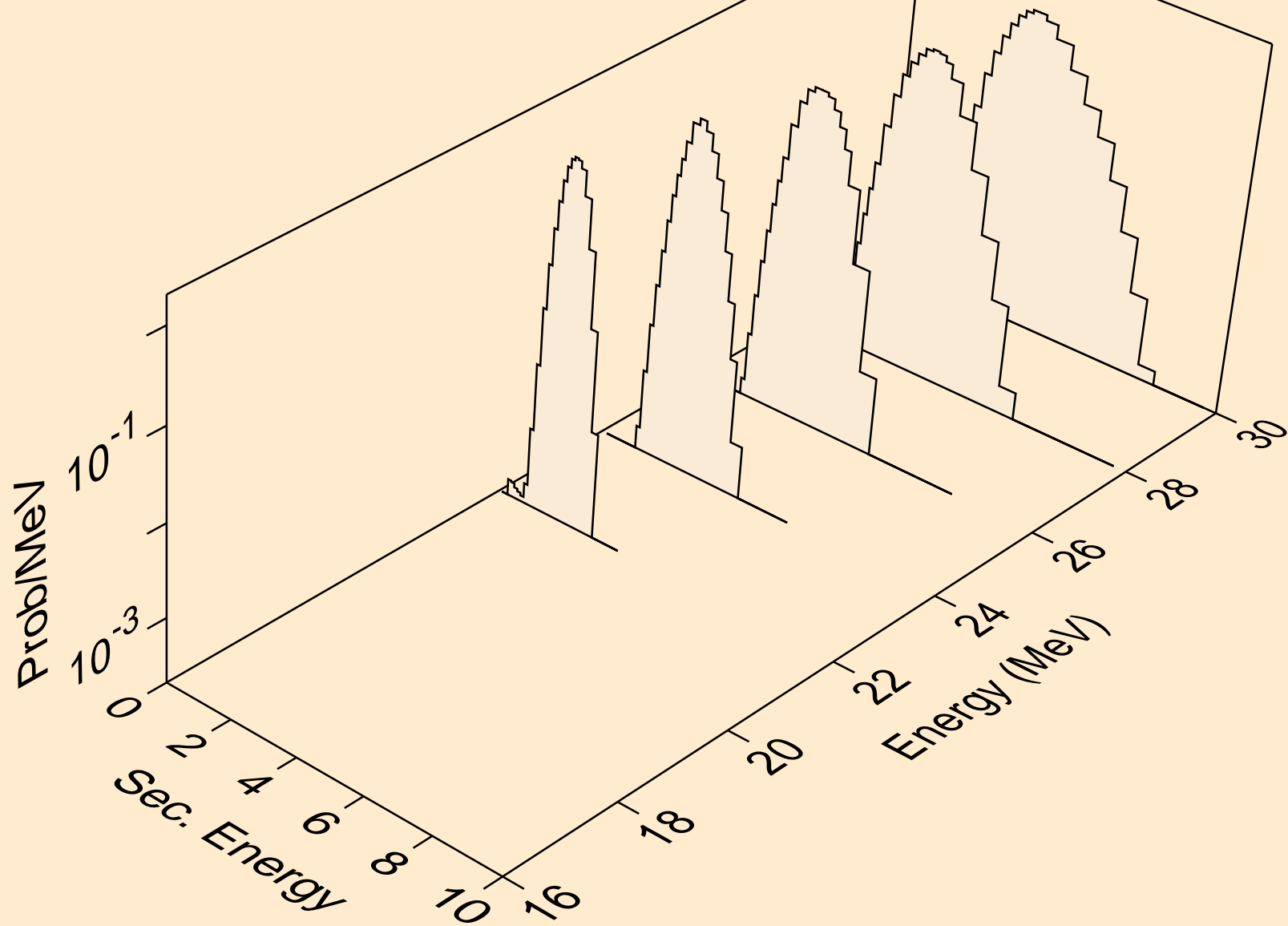

PD101 PROTON ACER TENDL-2024 LIBRARY; T=0.K  
Photon emission for (z,n)

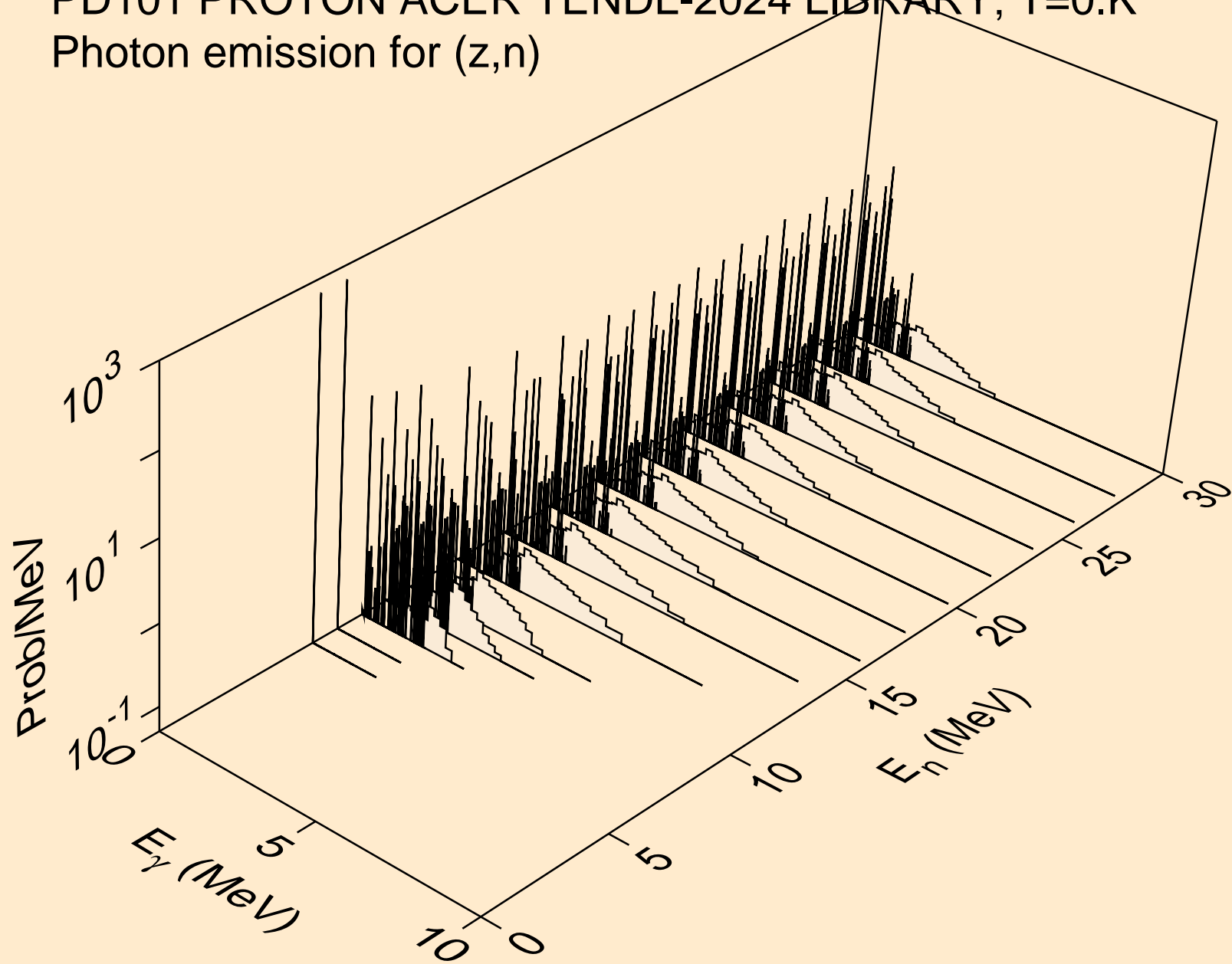

PD101 PROTON ACER TENDL-2024 LIBRARY; T=0.K  
Photon emission for (z,x)

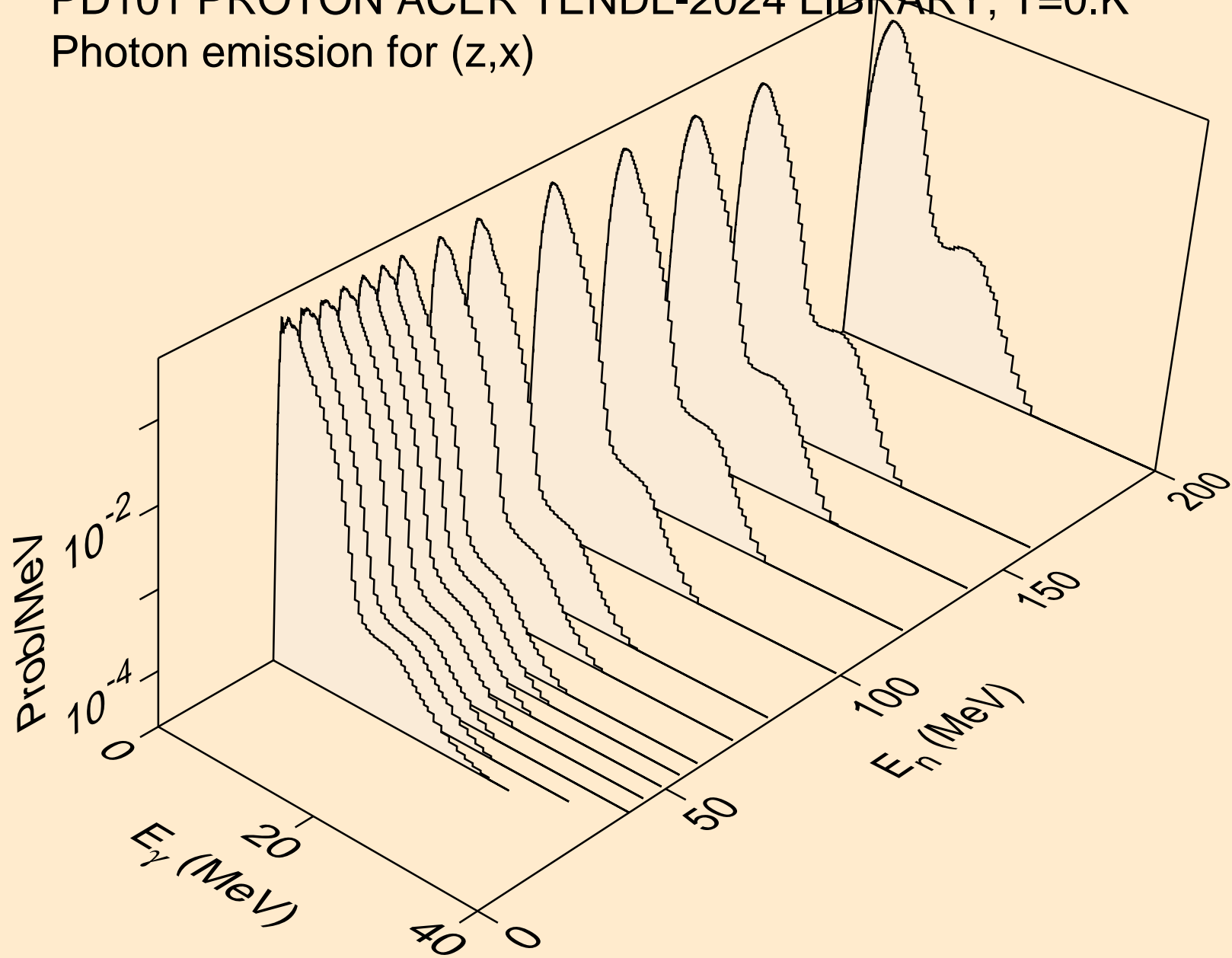

PD101 PROTON ACER TENDL-2024 LIBRARY; T=0.K  
Photon emission for (n,2nd)

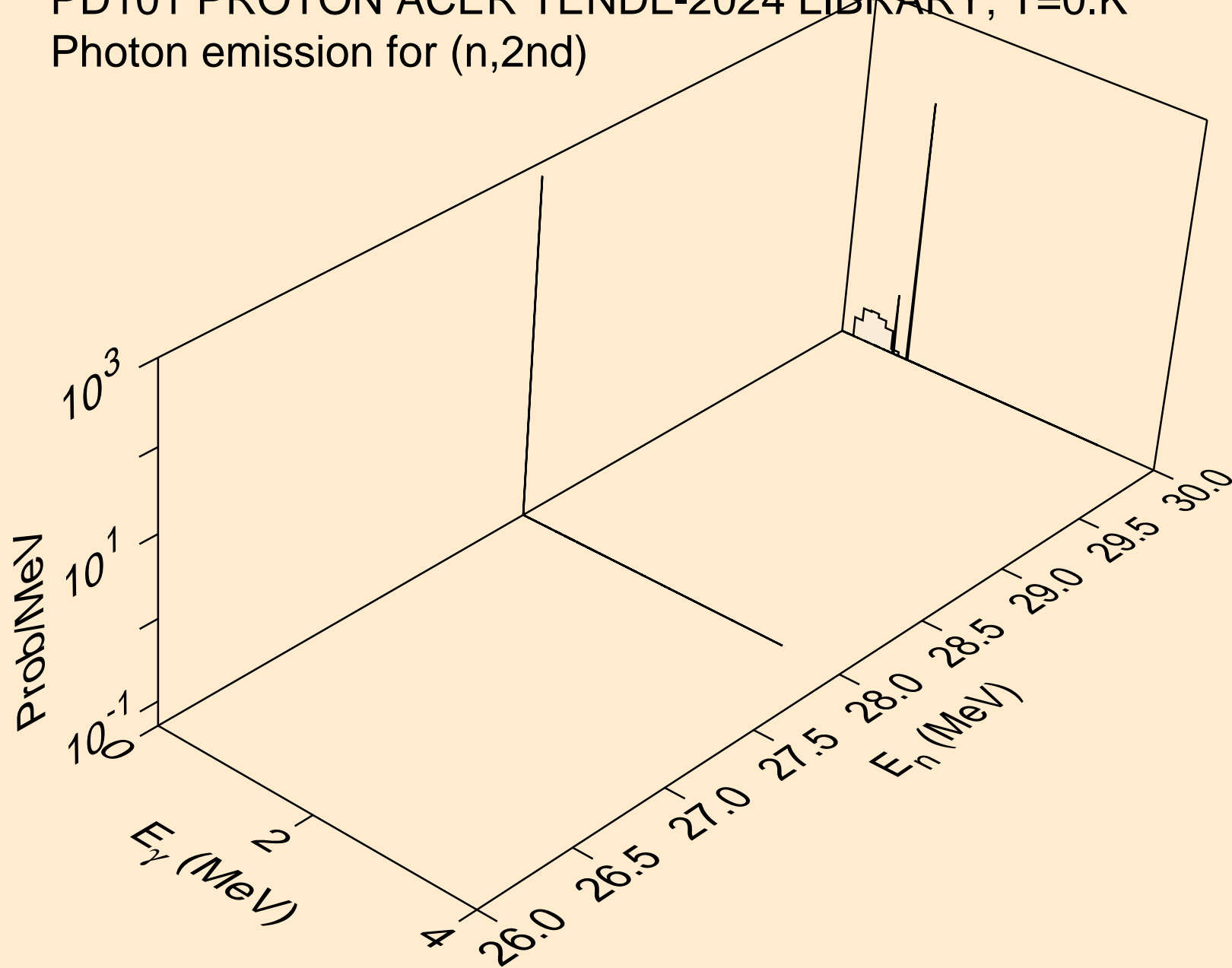

PD101 PROTON ACER TENDL-2024 LIBRARY; T=0.K  
Photon emission for (n,2n)

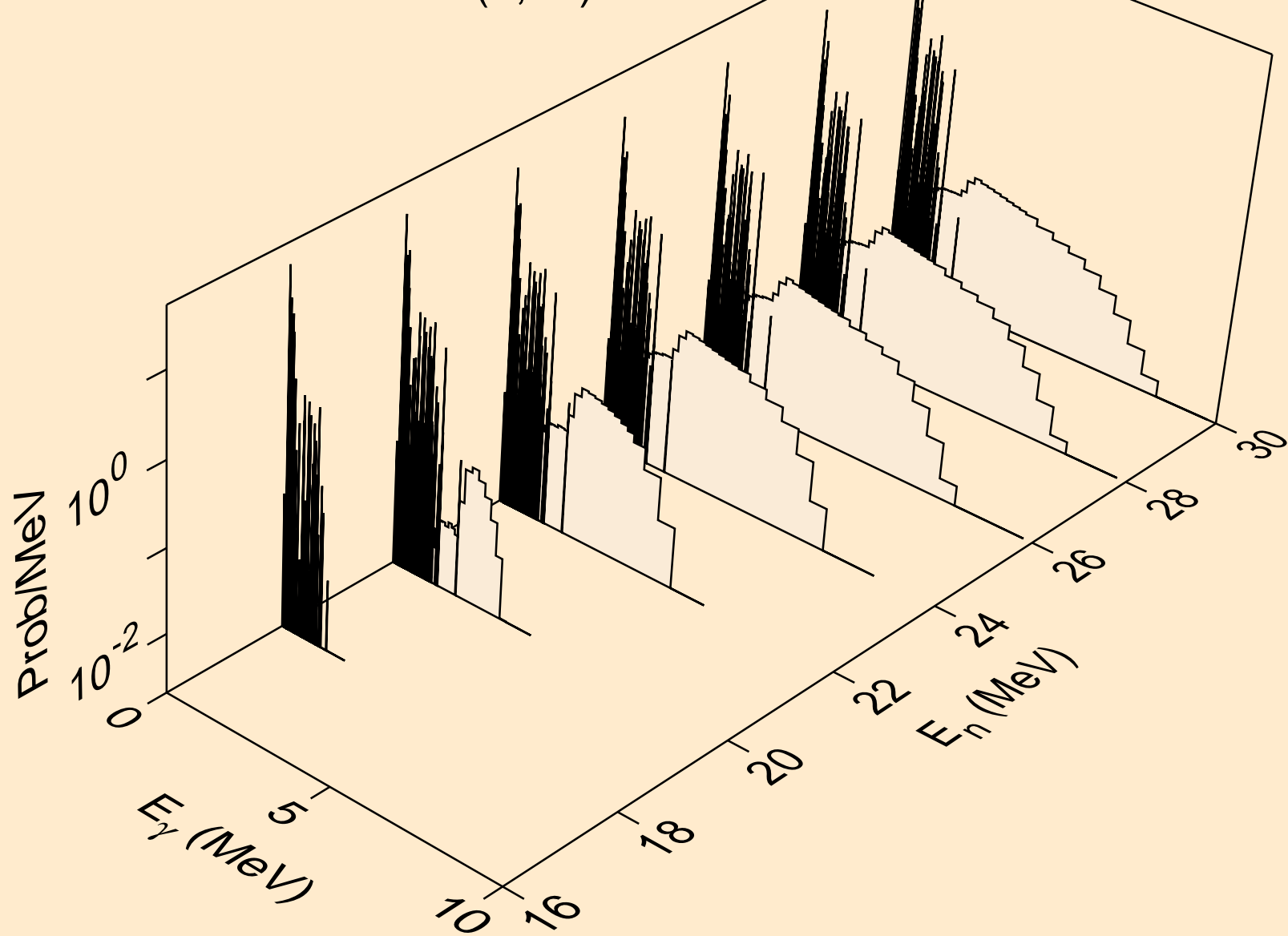

PD101 PROTON ACER TENDL-2024 LIBRARY; T=0.K  
Photon emission for (n,3n)

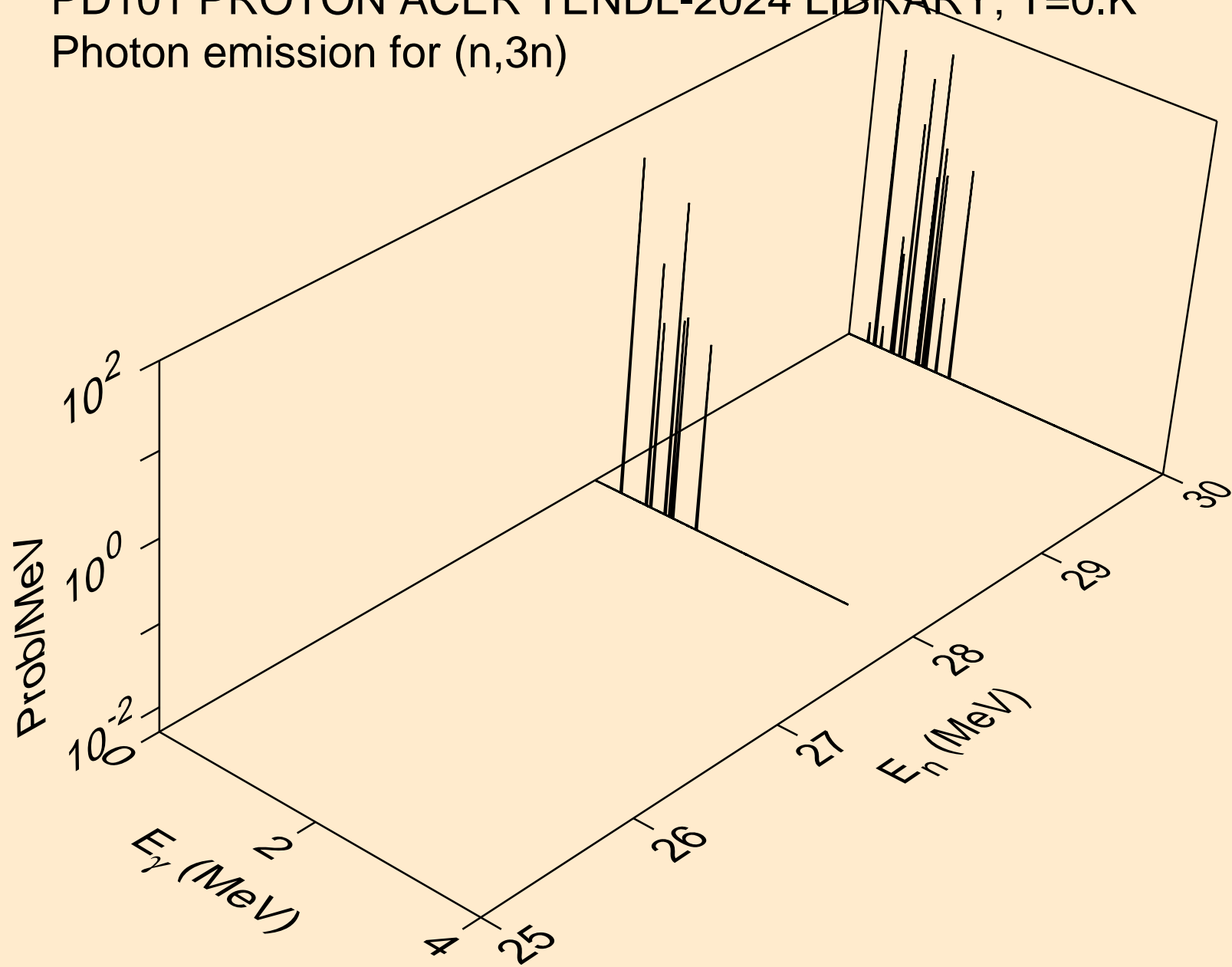

PD101 PROTON ACER TENDL-2024 LIBRARY; T=0.K  
Photon emission for (n,n\*)a

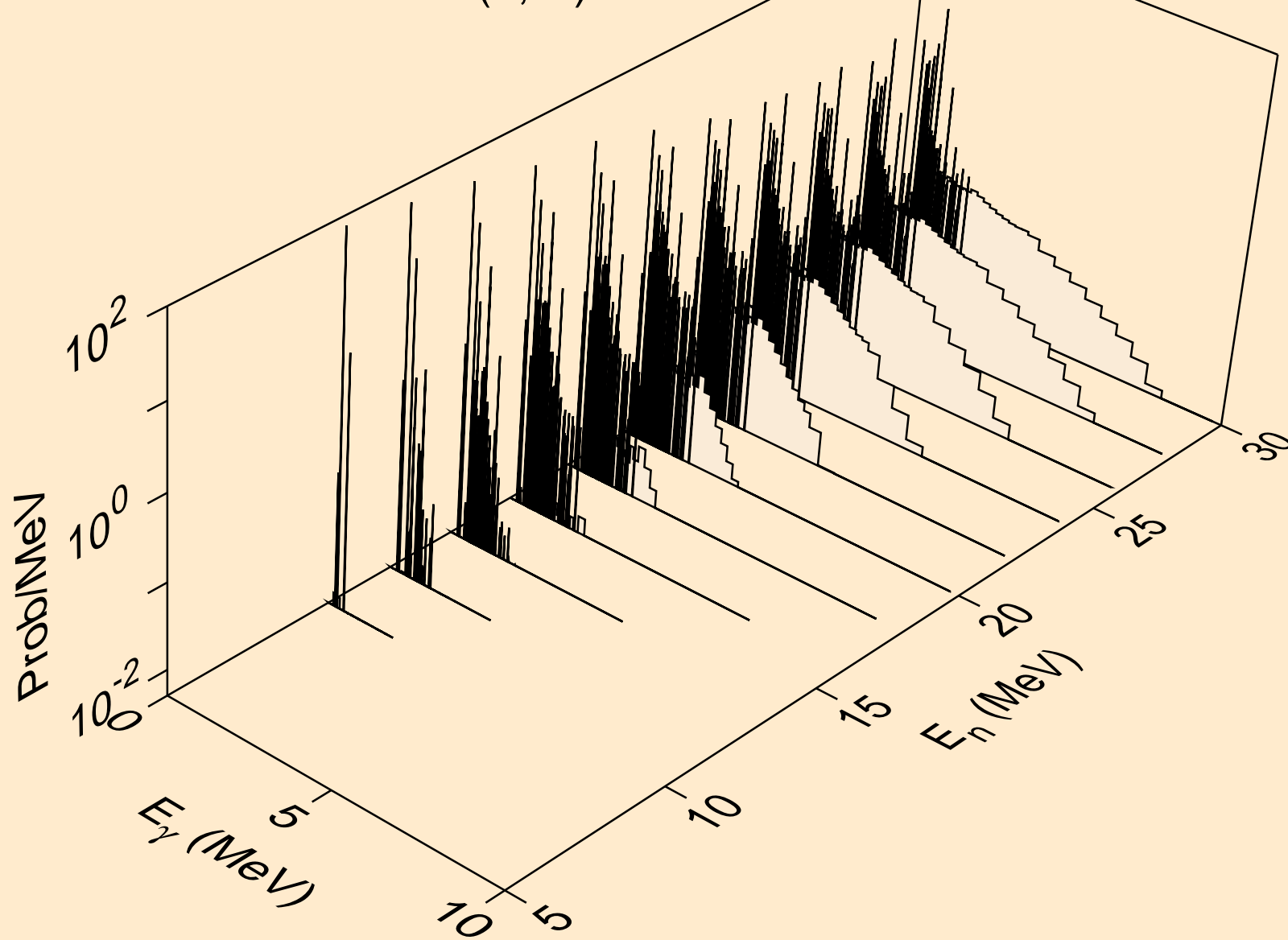

PD101 PROTON ACER TENDL-2024 LIBRARY; T=0.K  
Photon emission for (n,2n)a

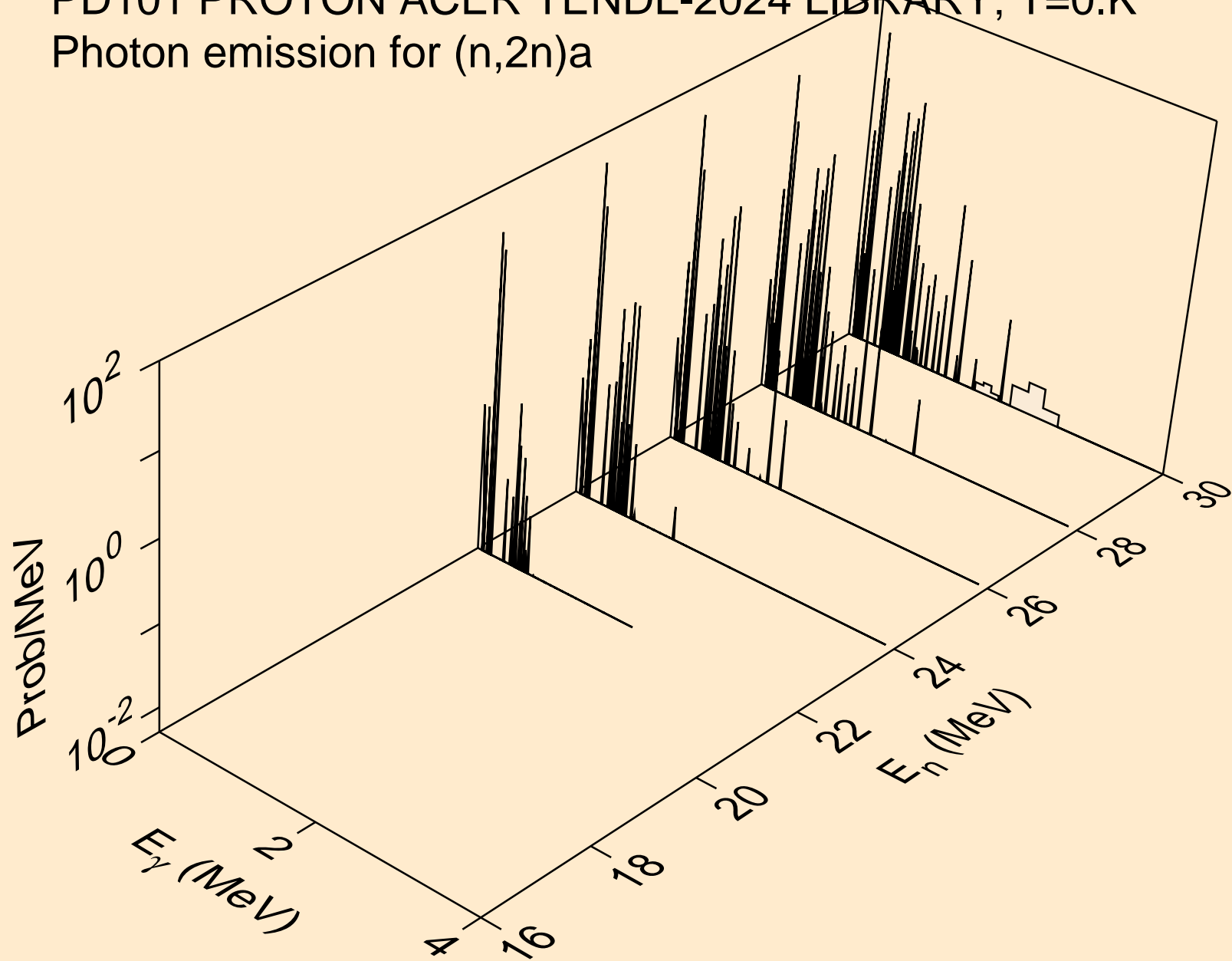

PD101 PROTON ACER TENDL-2024 LIBRARY; T=0.K  
Photon emission for (n,n\*)p

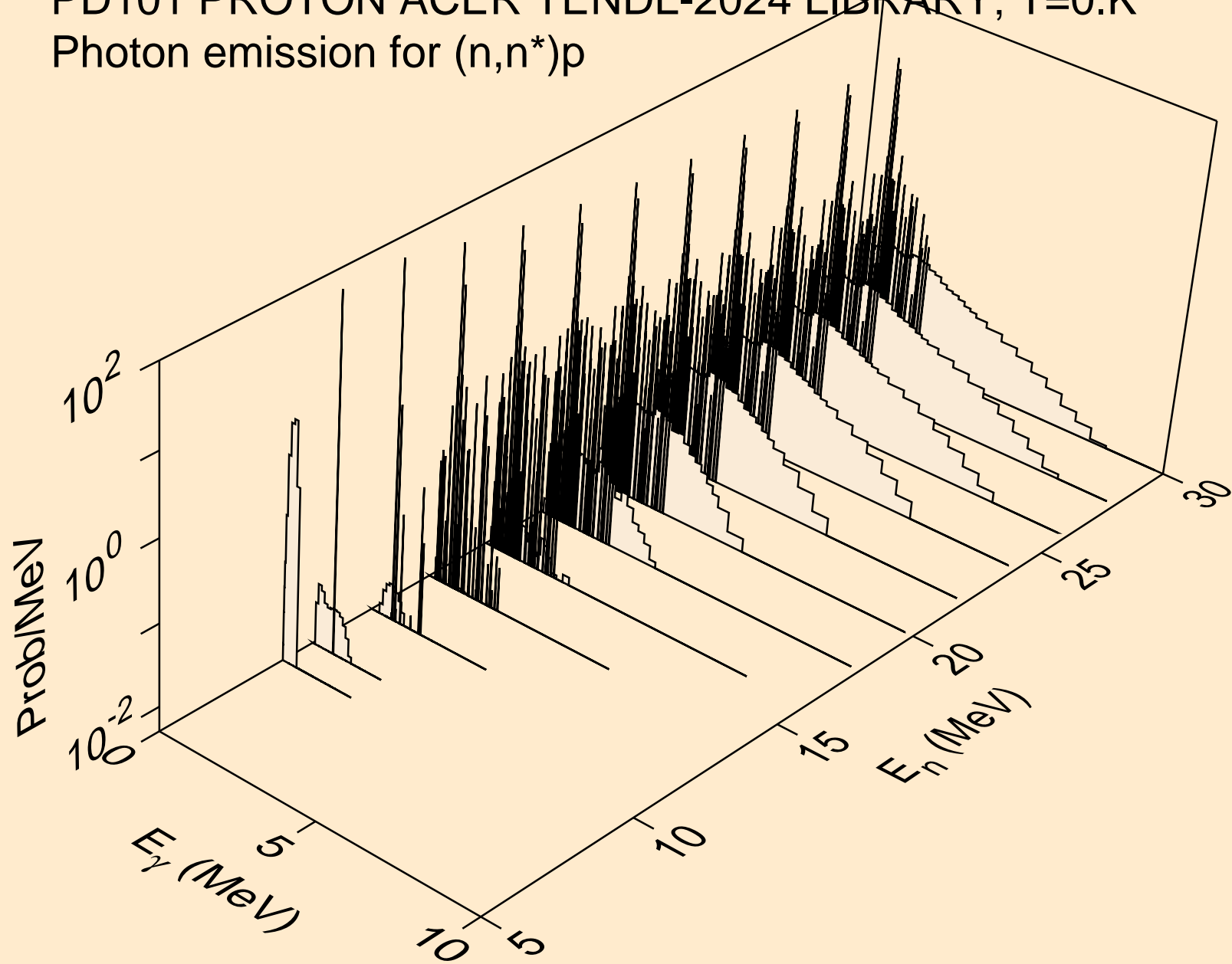

PD101 PROTON ACER TENDL-2024 LIBRARY; T=0.K  
Photon emission for (n,n\*)2a

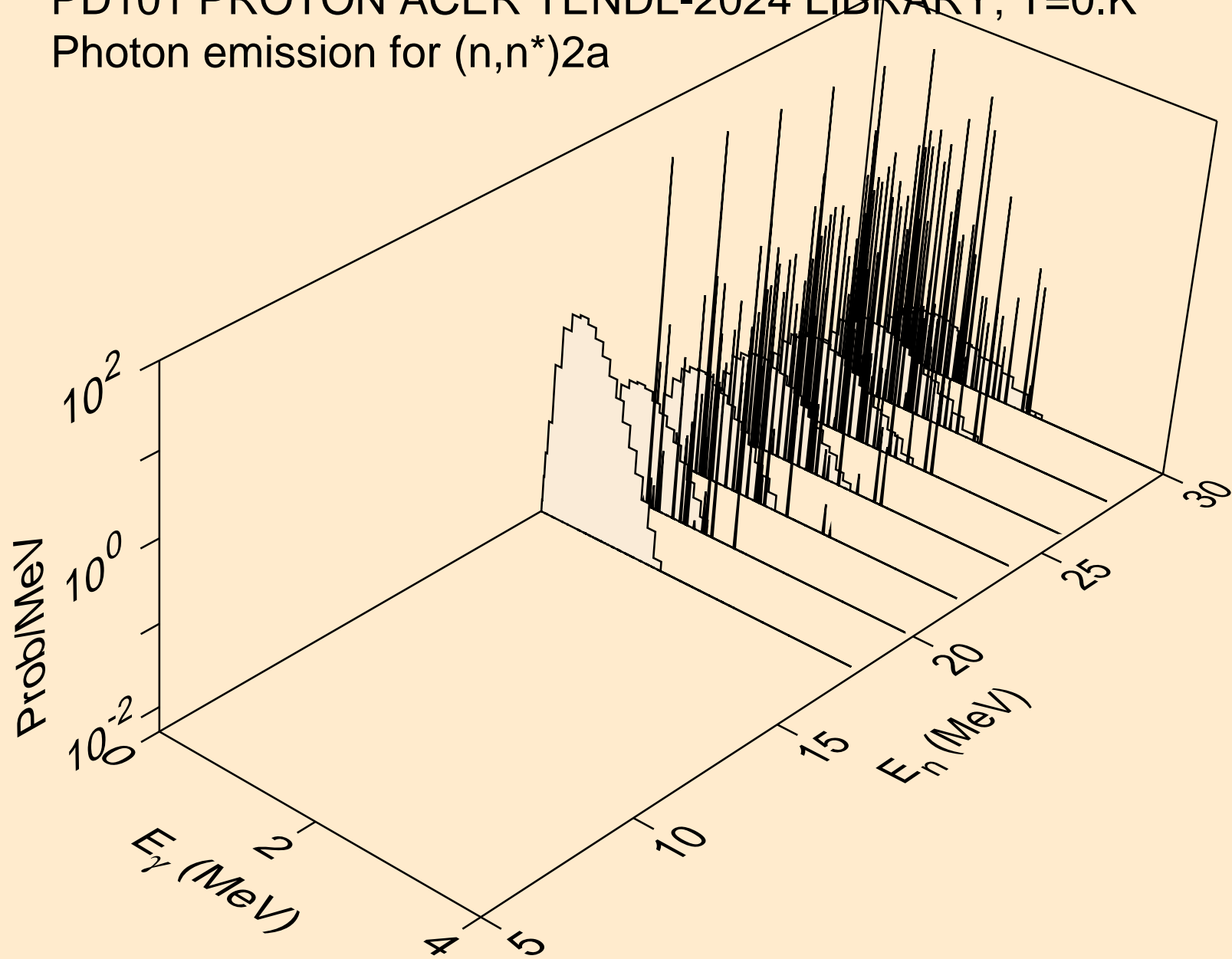

PD101 PROTON ACER TENDL-2024 LIBRARY; T=0.K  
Photon emission for (n,n\*)d

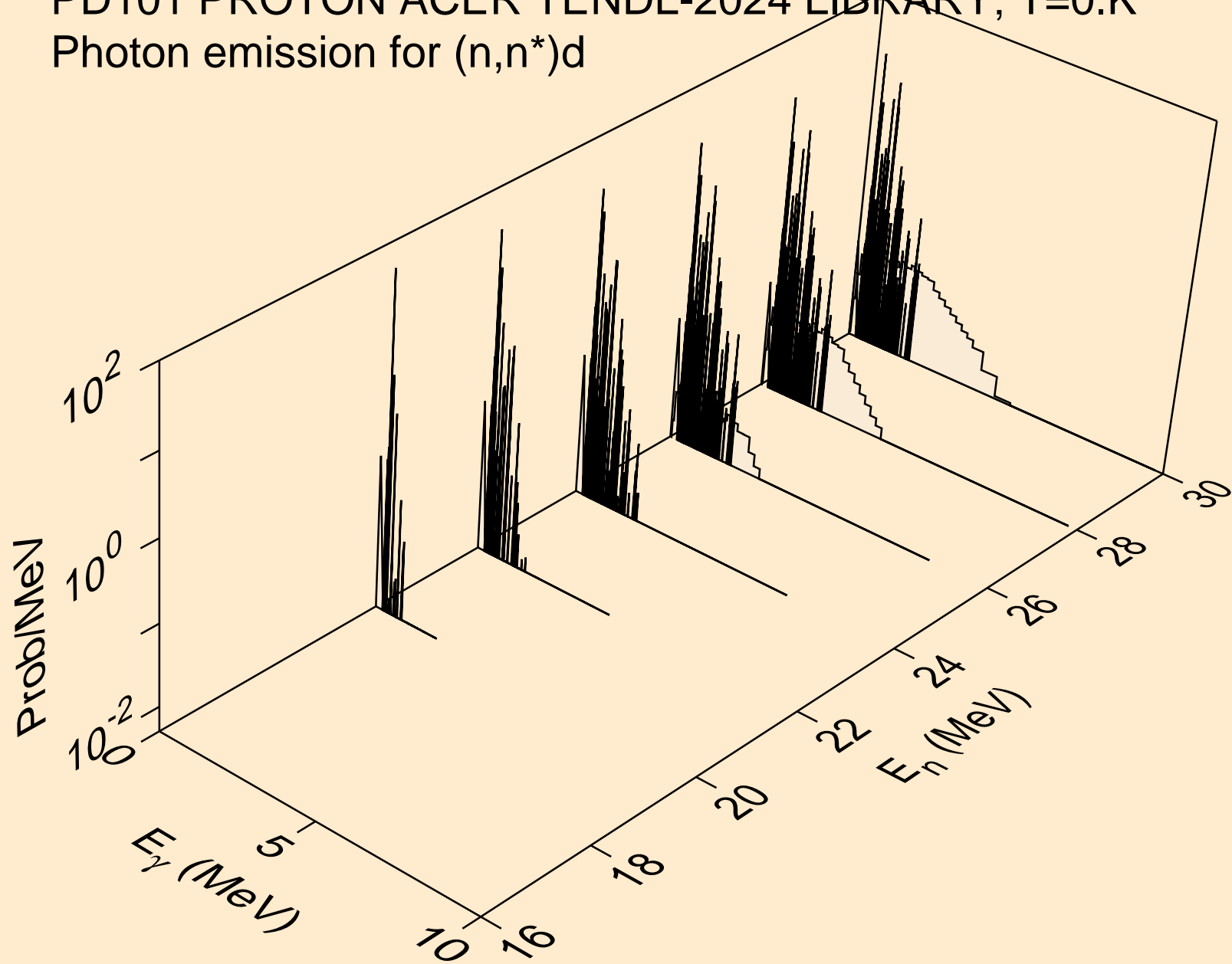

PD101 PROTON ACER TENDL-2024 LIBRARY; T=0.K  
Photon emission for (n,n\*)t

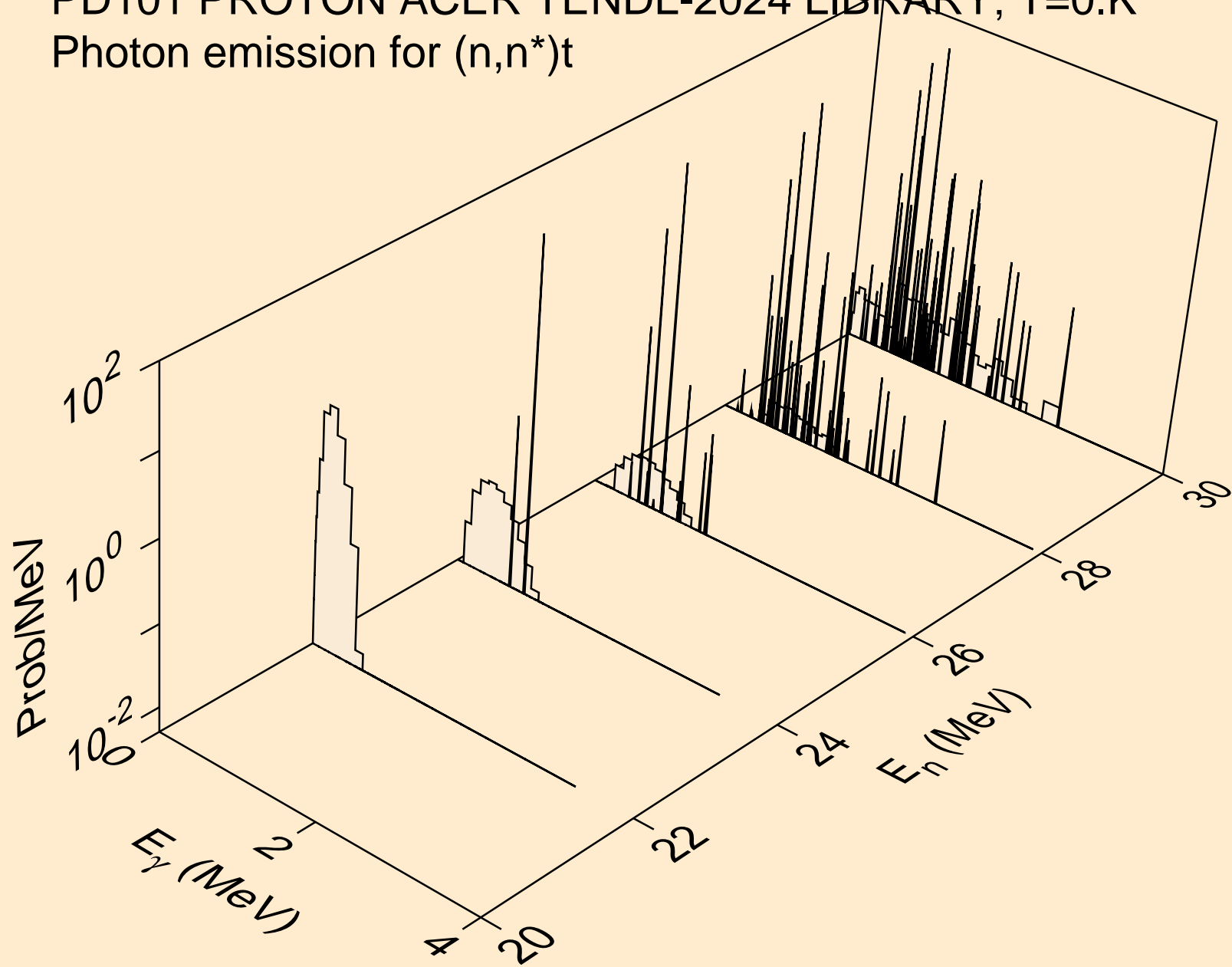

PD101 PROTON ACER TENDL-2024 LIBRARY; T=0.K  
Photon emission for (n,n\*)he3

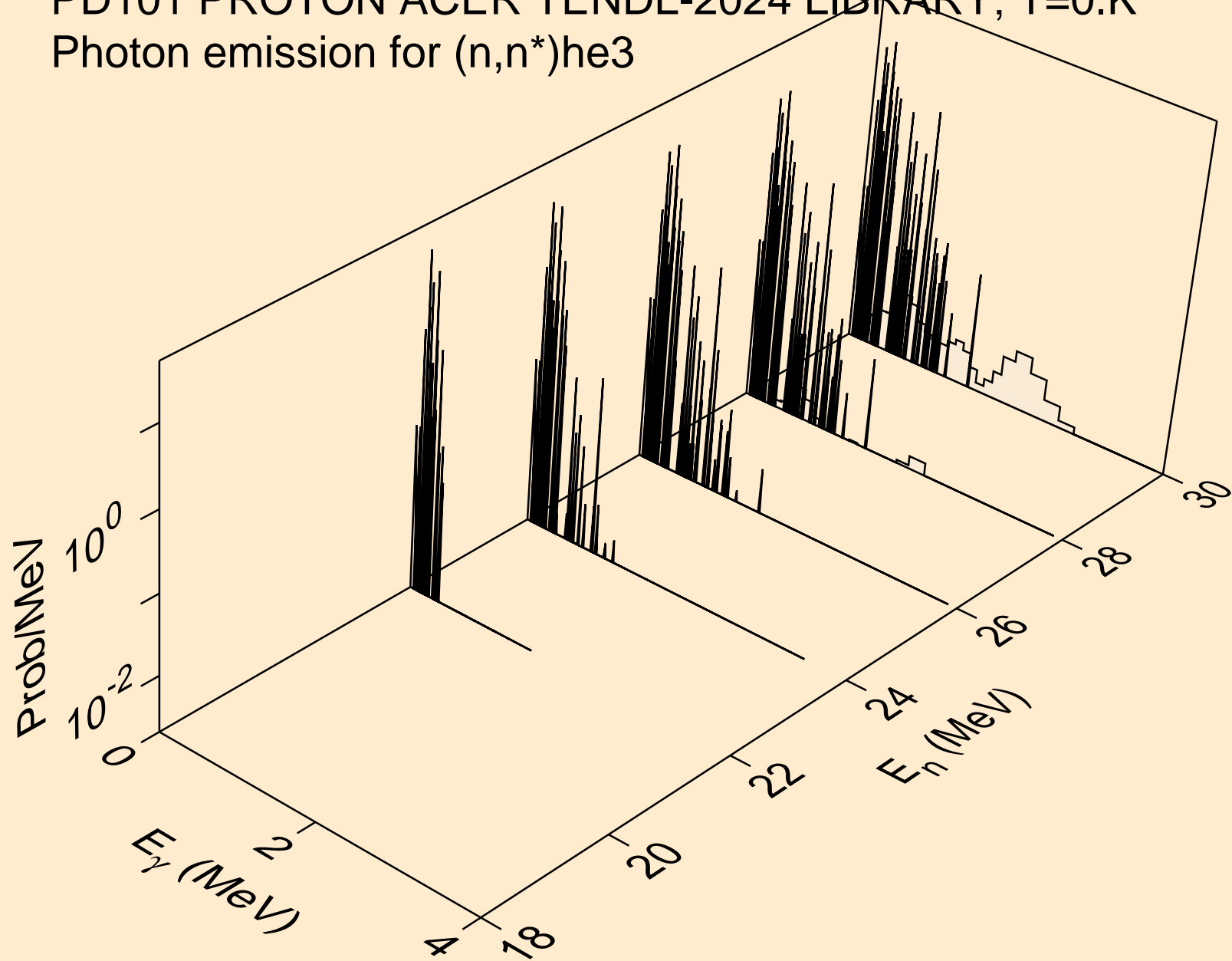

PD101 PROTON ACER TENDL-2024 LIBRARY; T=0.K  
Photon emission for (n,2np)

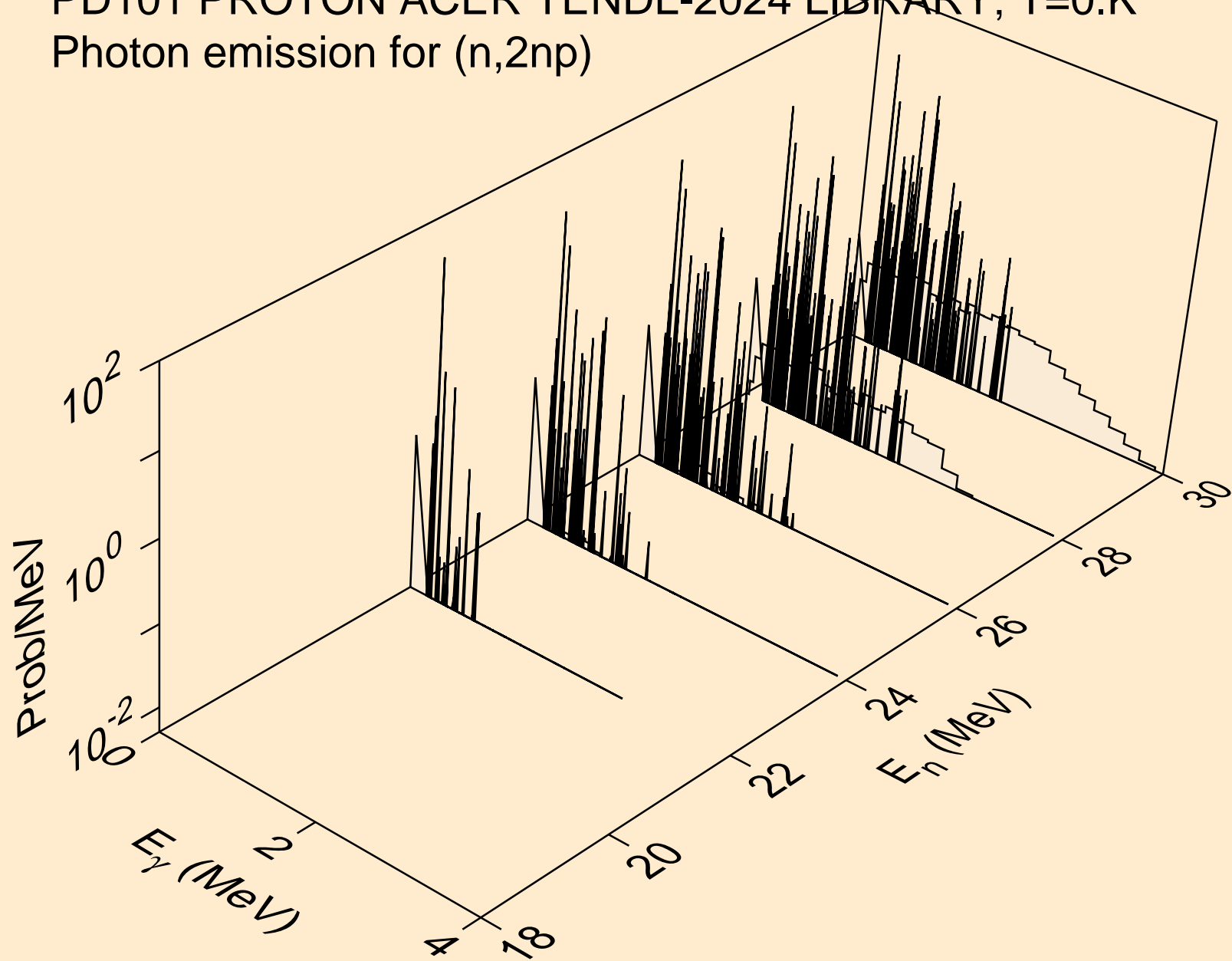

PD101 PROTON ACER TENDL-2024 LIBRARY; T=0.K  
Photon emission for (n,n2p)

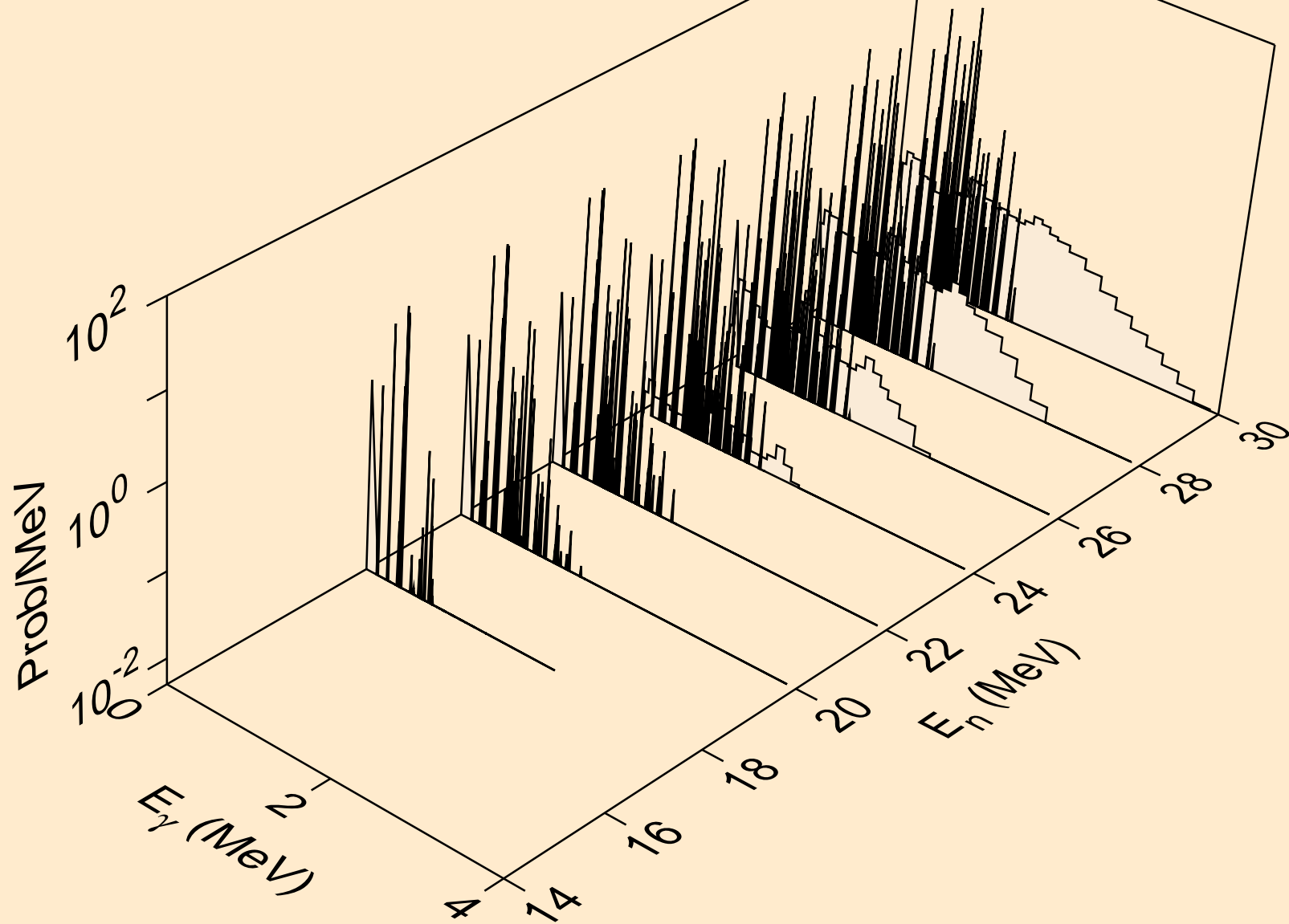

PD101 PROTON ACER TENDL-2024 LIBRARY; T=0.K  
Photon emission for (n,npa)

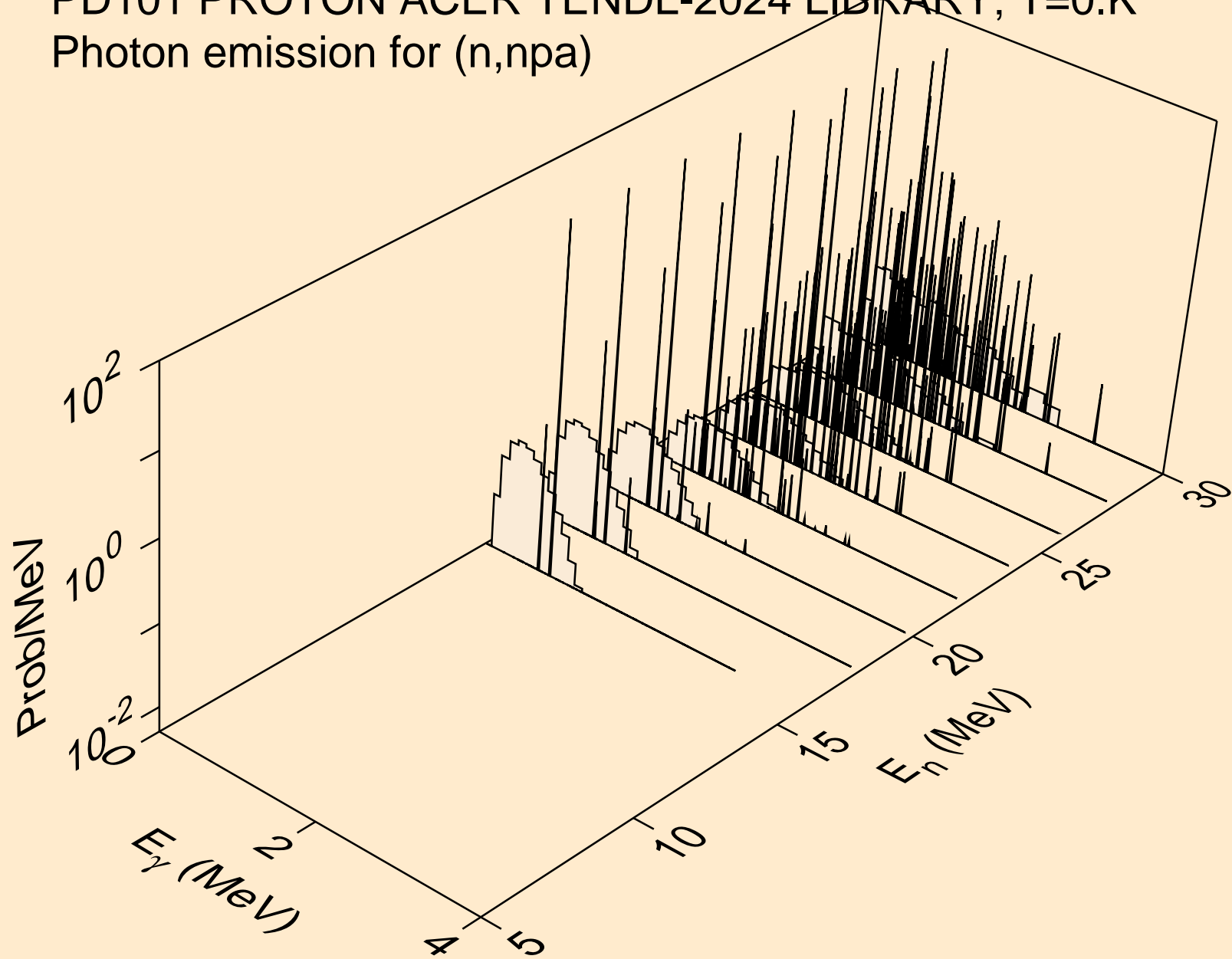

PD101 PROTON ACER TENDL-2024 LIBRARY; T=0.K  
Photon emission for (n,gma)

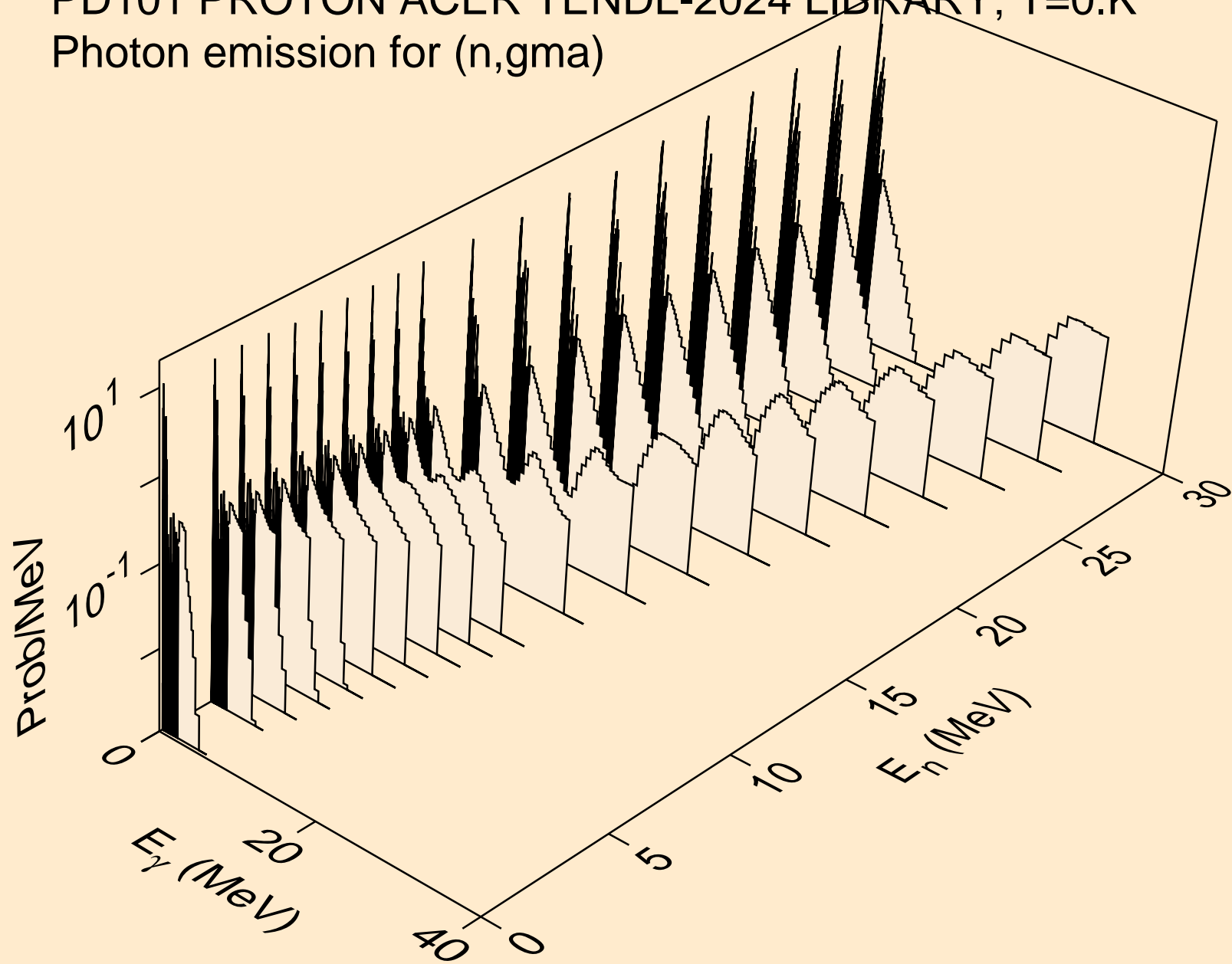

PD101 PROTON ACER TENDL-2024 LIBRARY; T=0.K  
Photon emission for inelastic

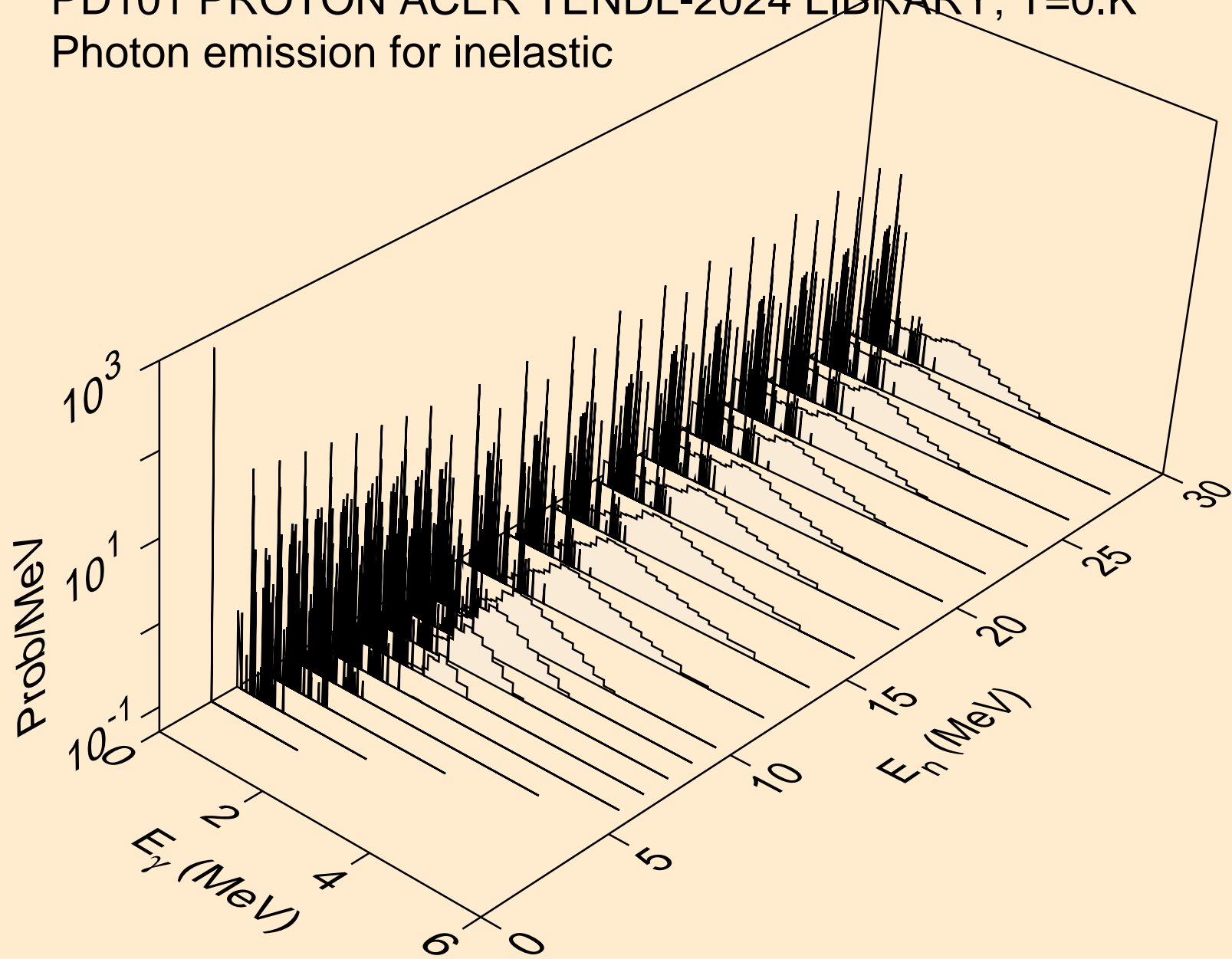

PD101 PROTON ACER TENDL-2024 LIBRARY; T=0.K  
Photon emission for (n,d)

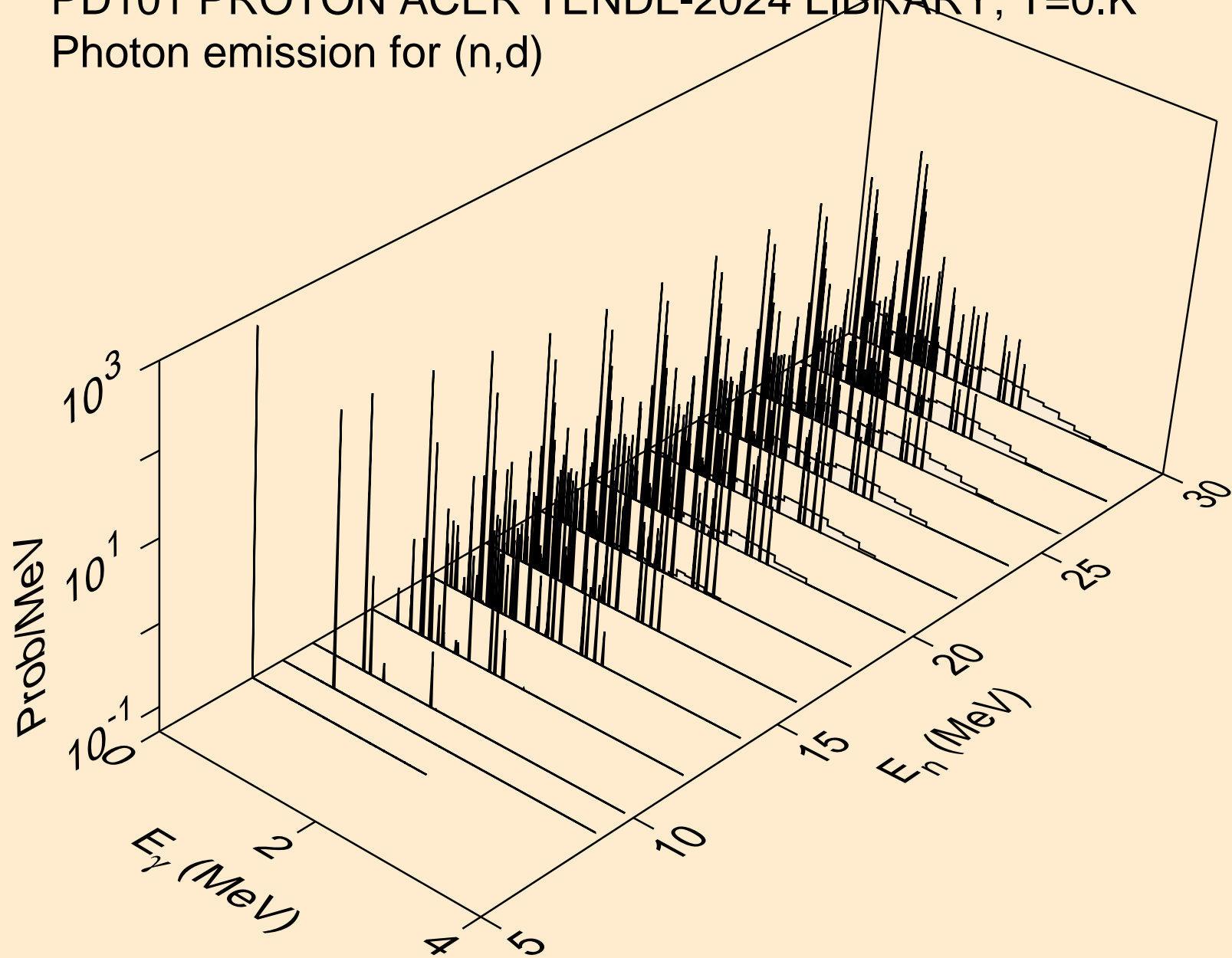

PD101 PROTON ACER TENDL-2024 LIBRARY; T=0.K  
Photon emission for (n,t)

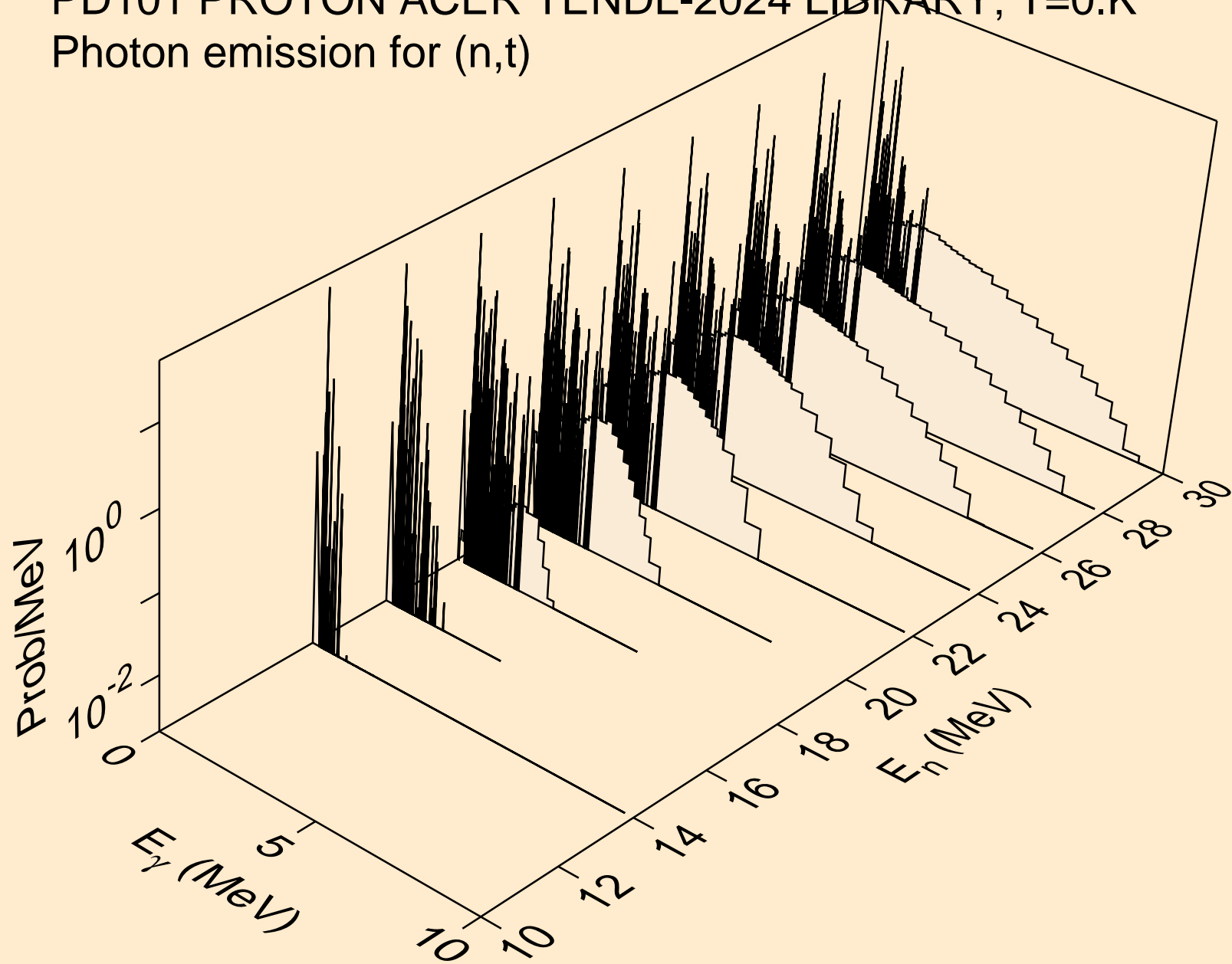

PD101 PROTON ACER TENDL-2024 LIBRARY; T=0.K  
Photon emission for (n,he3)

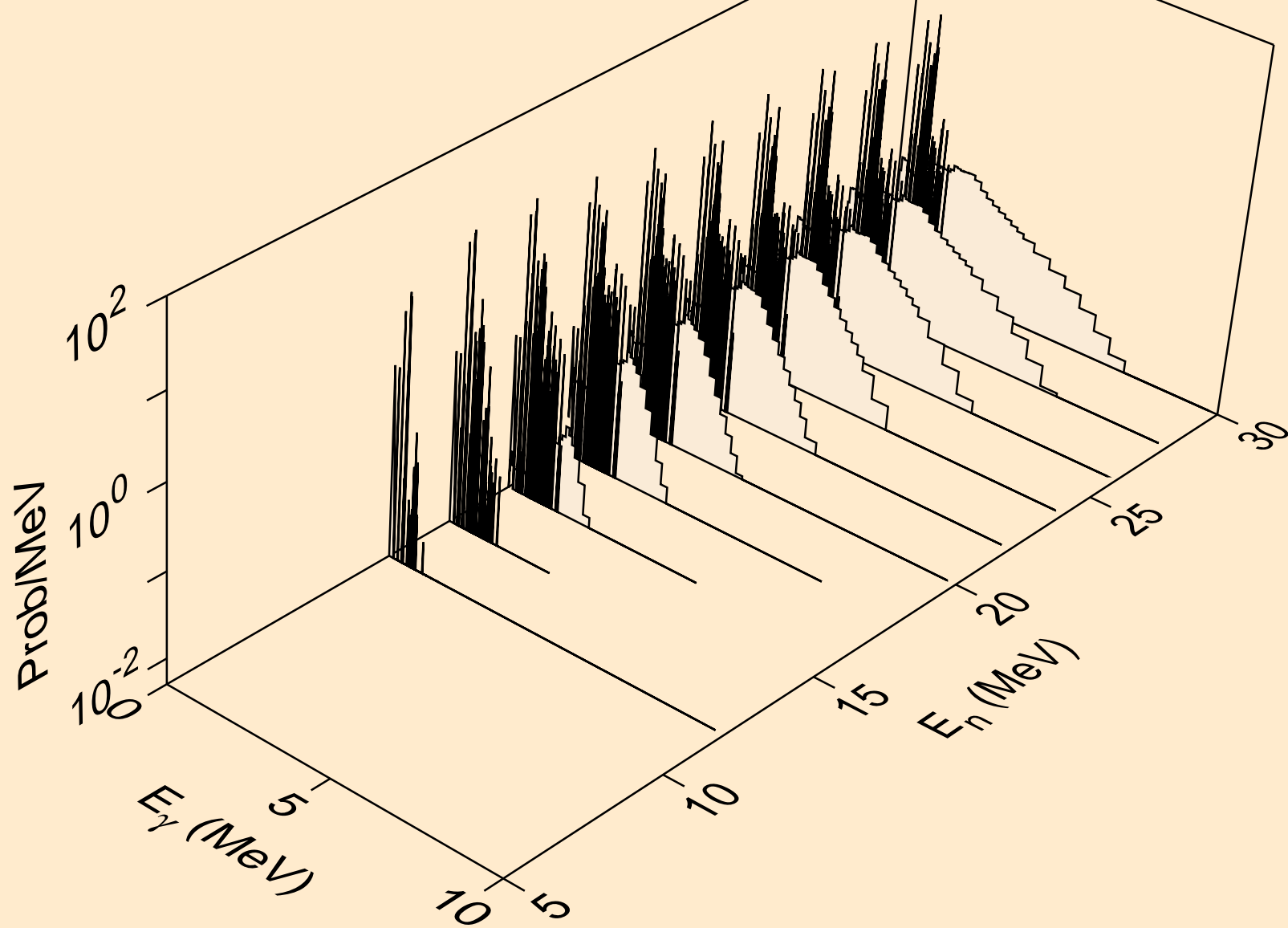

PD101 PROTON ACER TENDL-2024 LIBRARY; T=0.K  
Photon emission for (n,a)

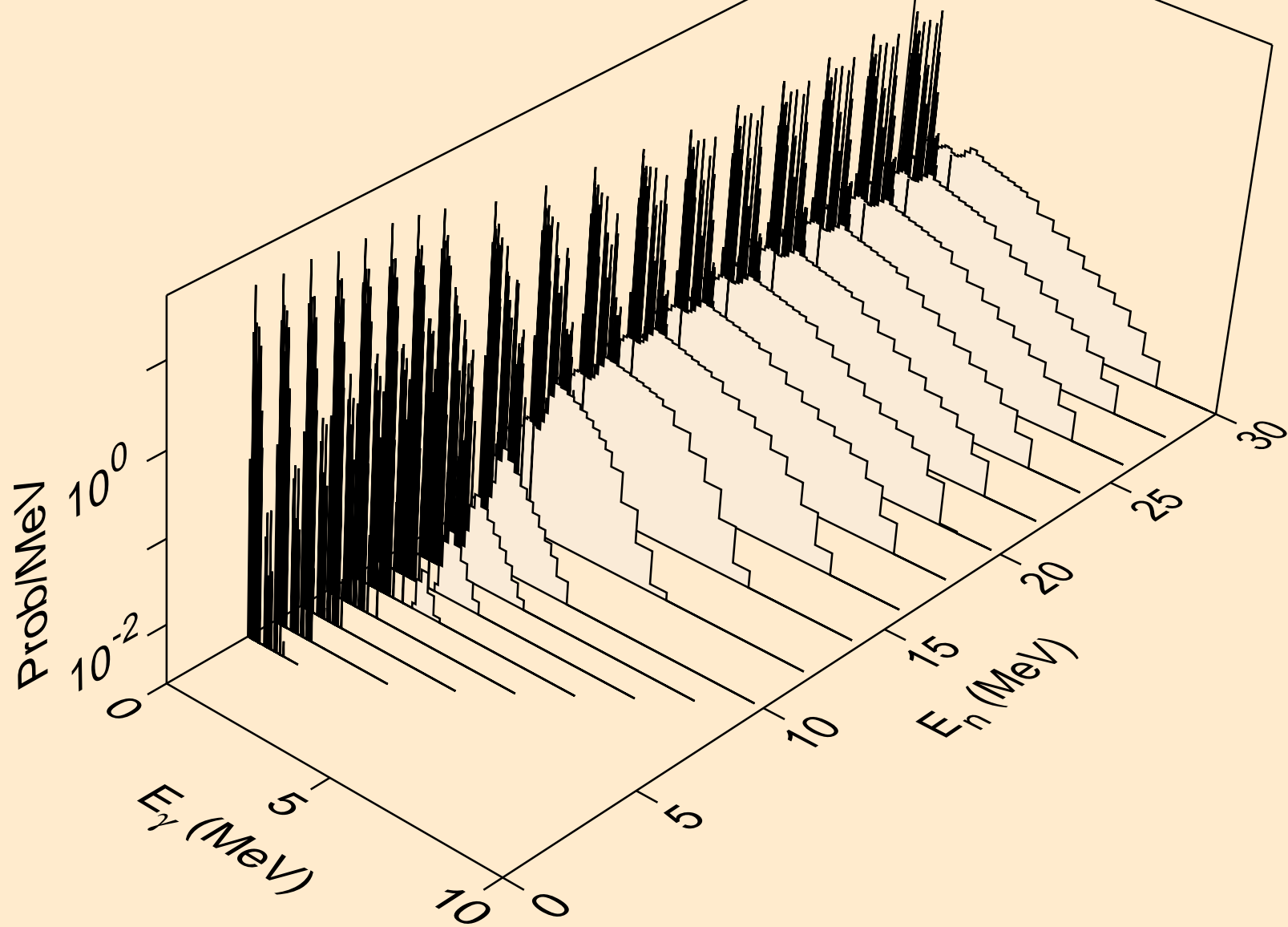

PD101 PROTON ACER TENDL-2024 LIBRARY; T=0.K  
Photon emission for (n,2a)

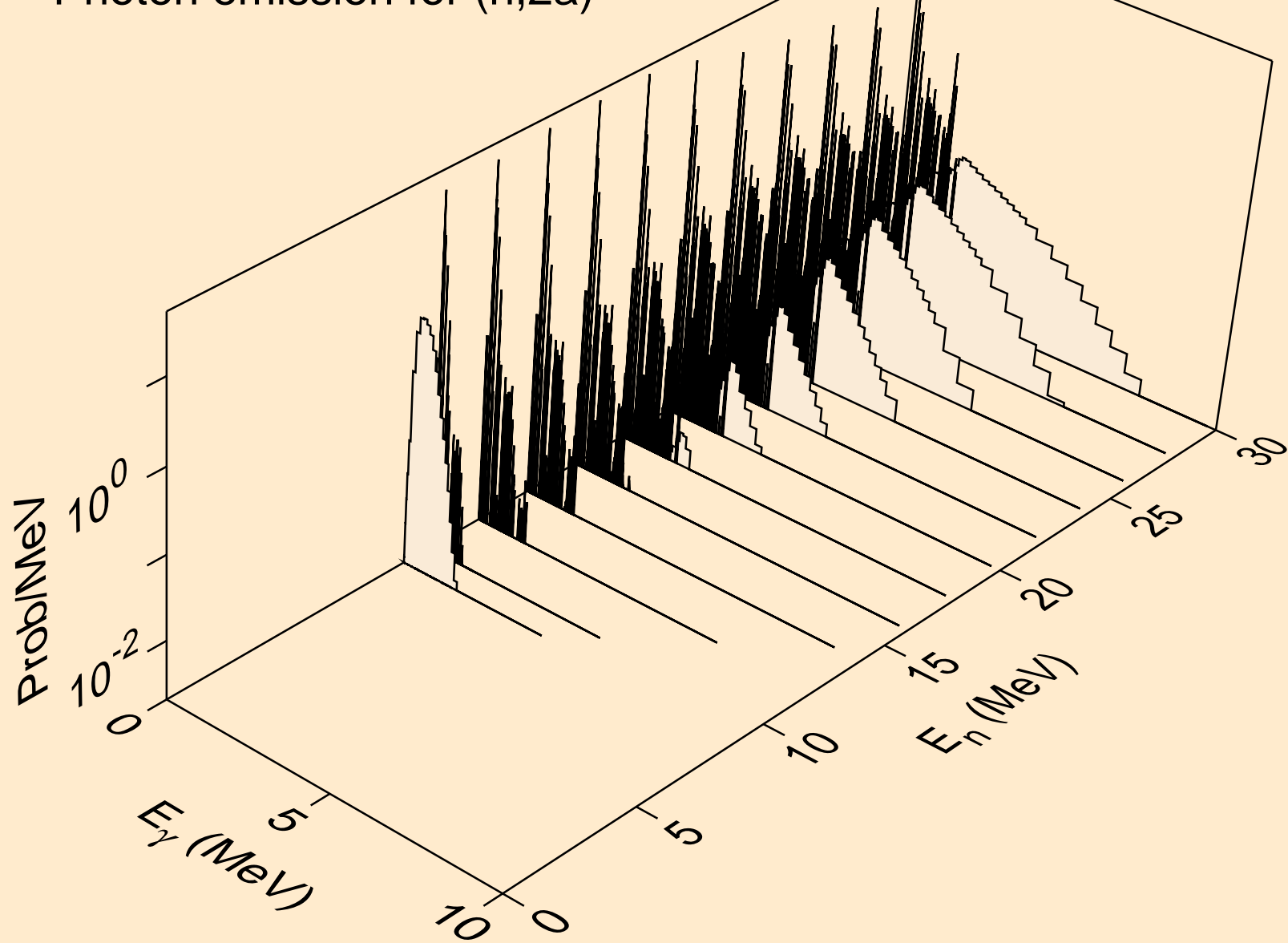

PD101 PROTON ACER TENDL-2024 LIBRARY; T=0.K  
Photon emission for (n,2p)

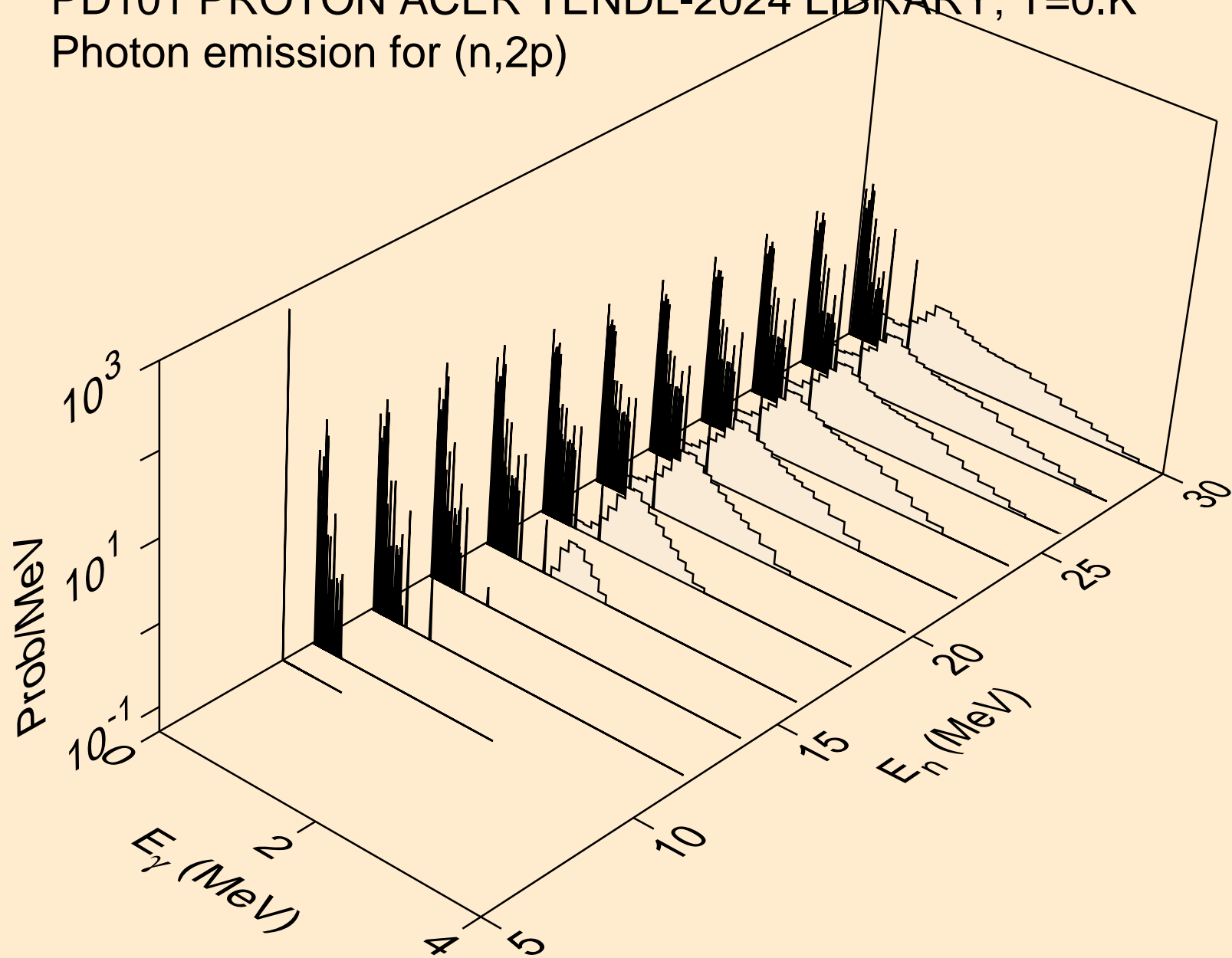

PD101 PROTON ACER TENDL-2024 LIBRARY; T=0.K  
Photon emission for (n,pa)

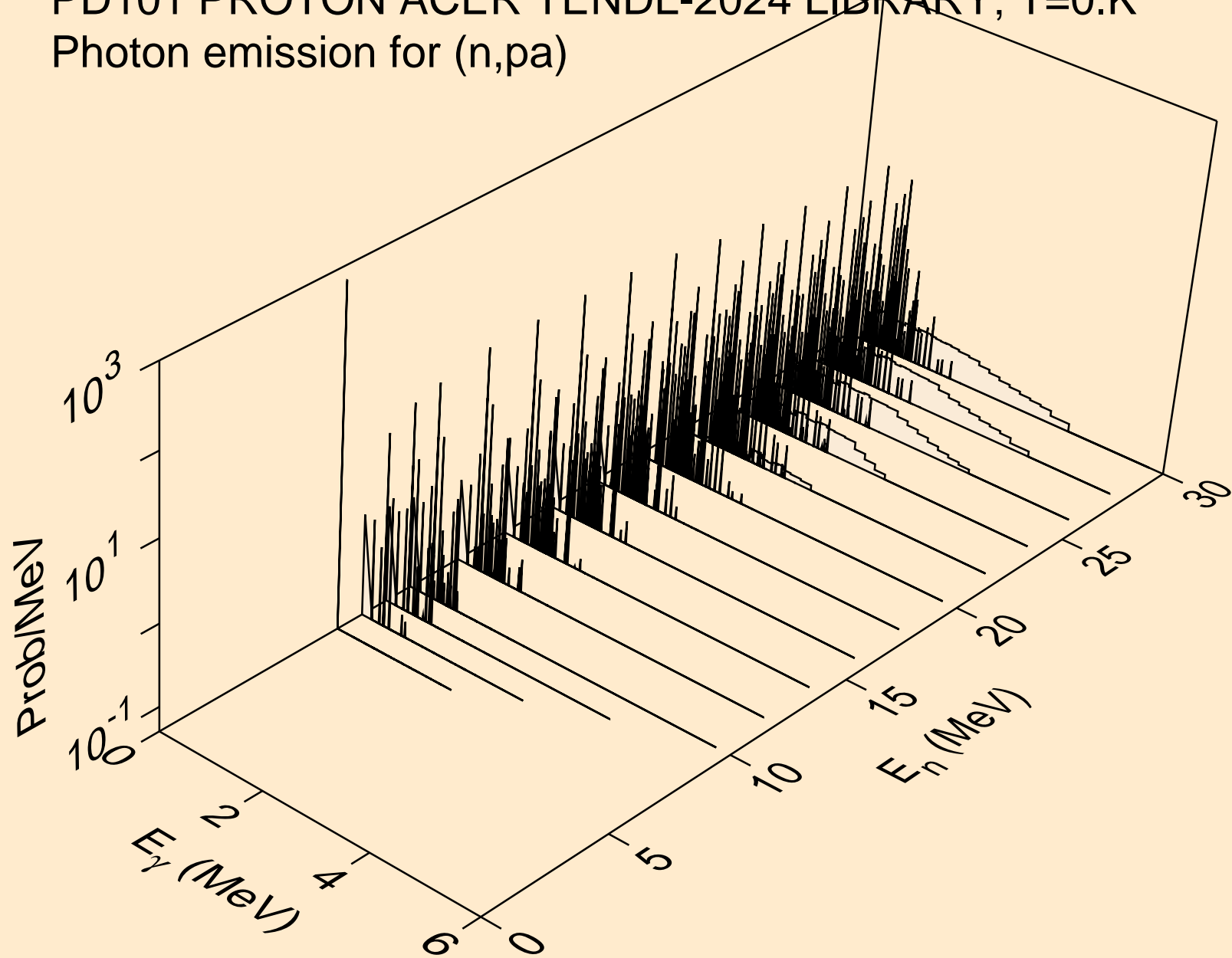

PD101 PROTON ACER TENDL-2024 LIBRARY; T=0.K  
Photon emission for (n,pd)

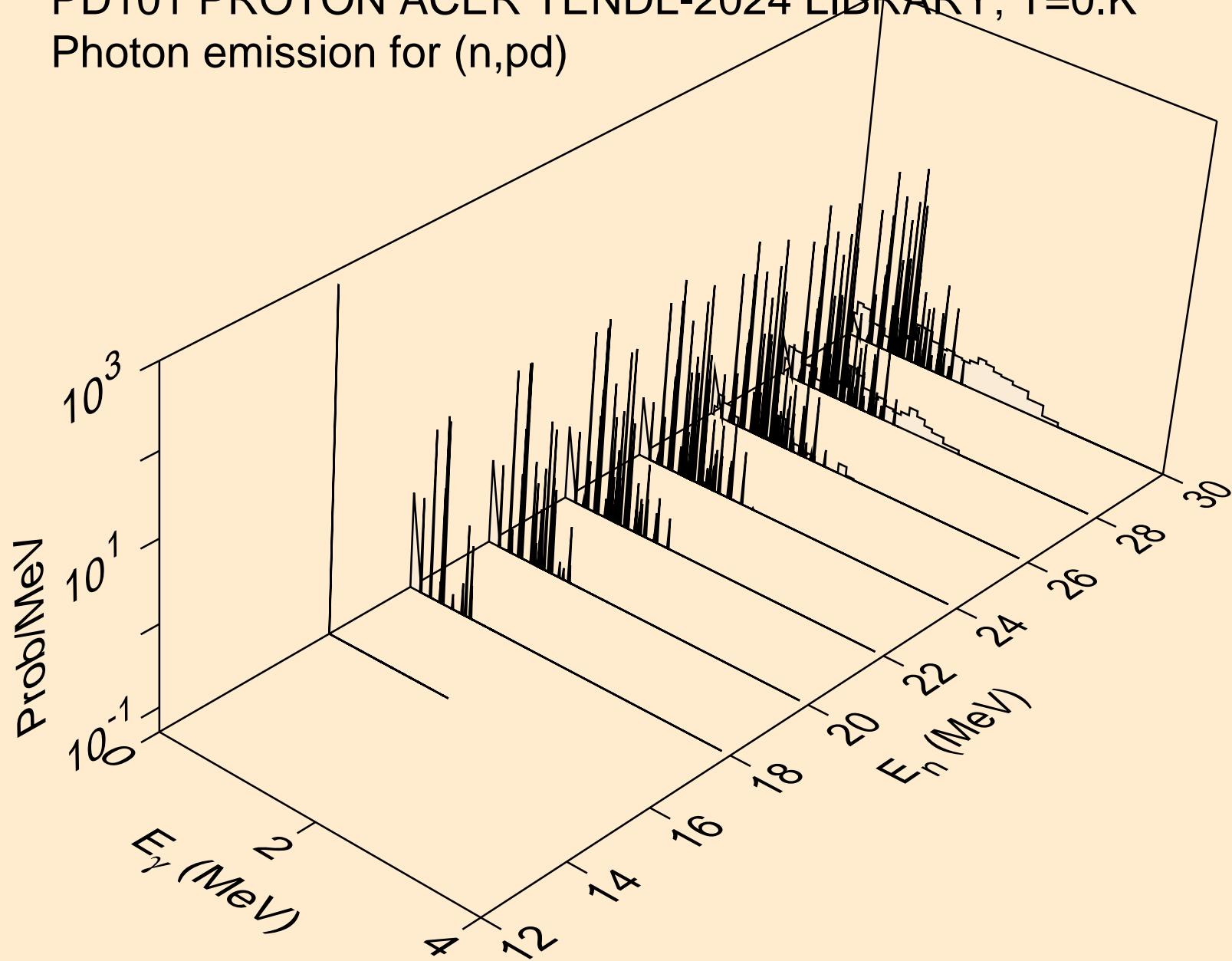

PD101 PROTON ACER TENDL-2024 LIBRARY; T=0.K  
Photon emission for (n,pt)

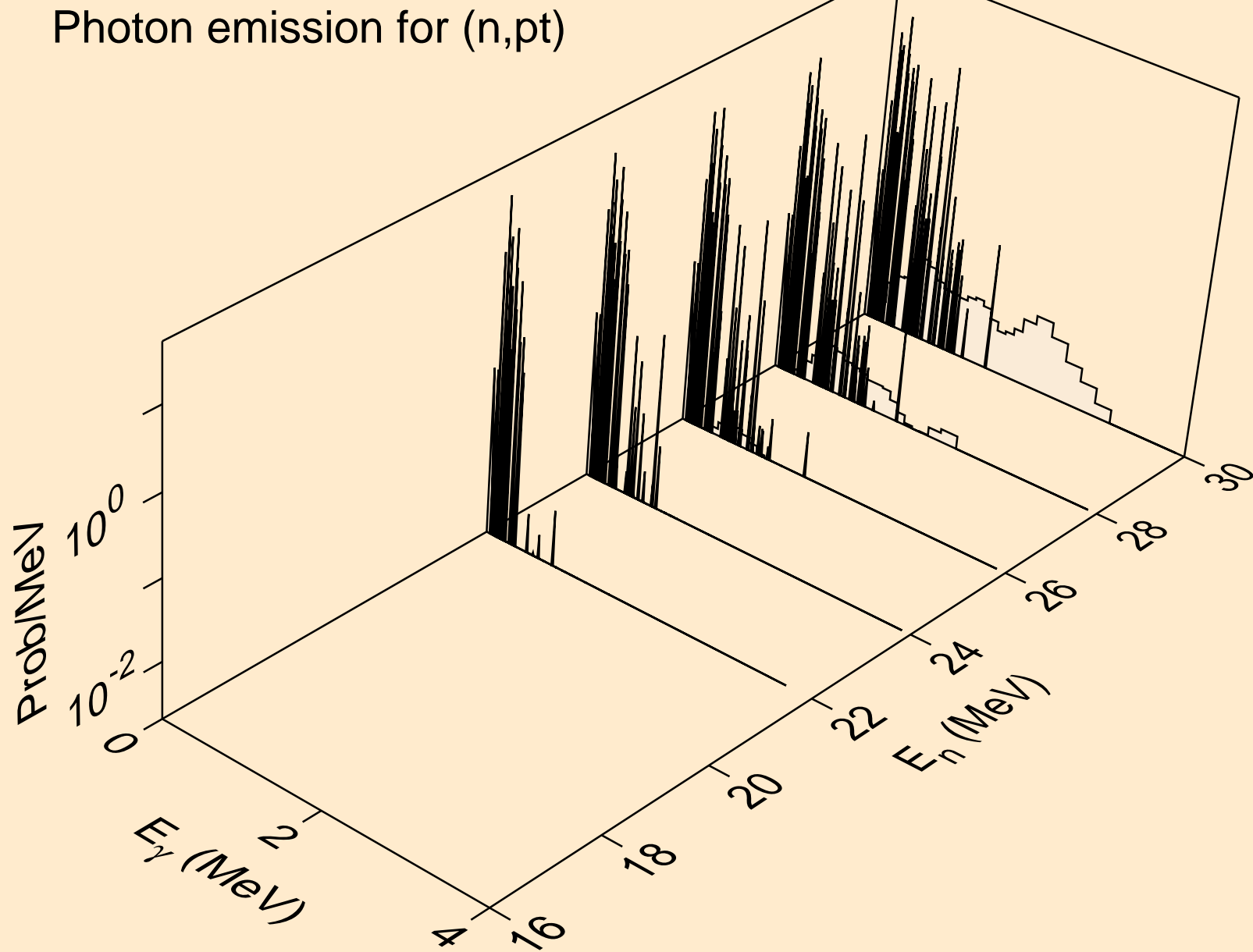

PD101 PROTON ACER TENDL-2024 LIBRARY; T=0.K  
Photon emission for (n,da)

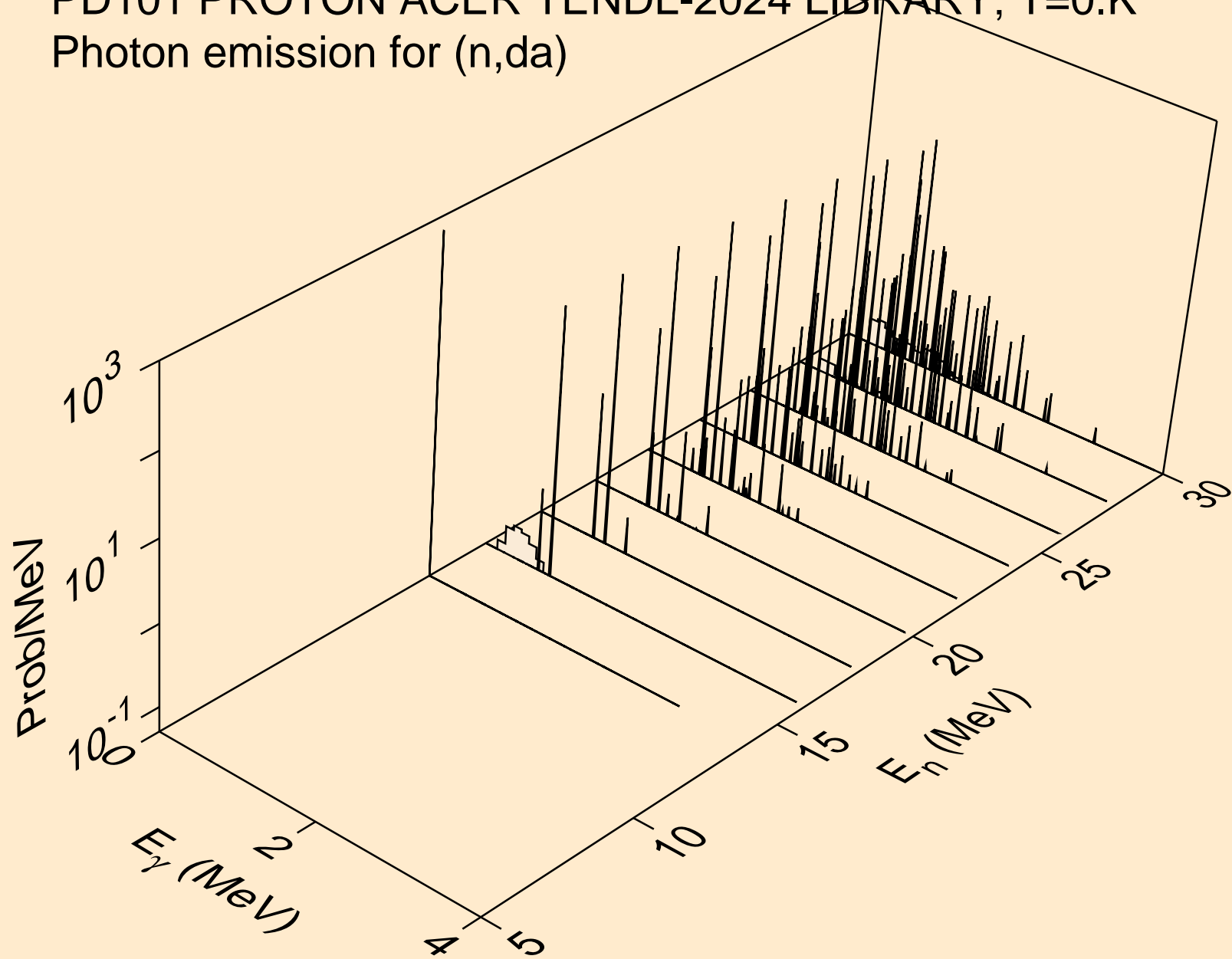

PD101 PROTON ACER TENDL-2024 LIBRARY; T=0.K  
Particle heating contributions

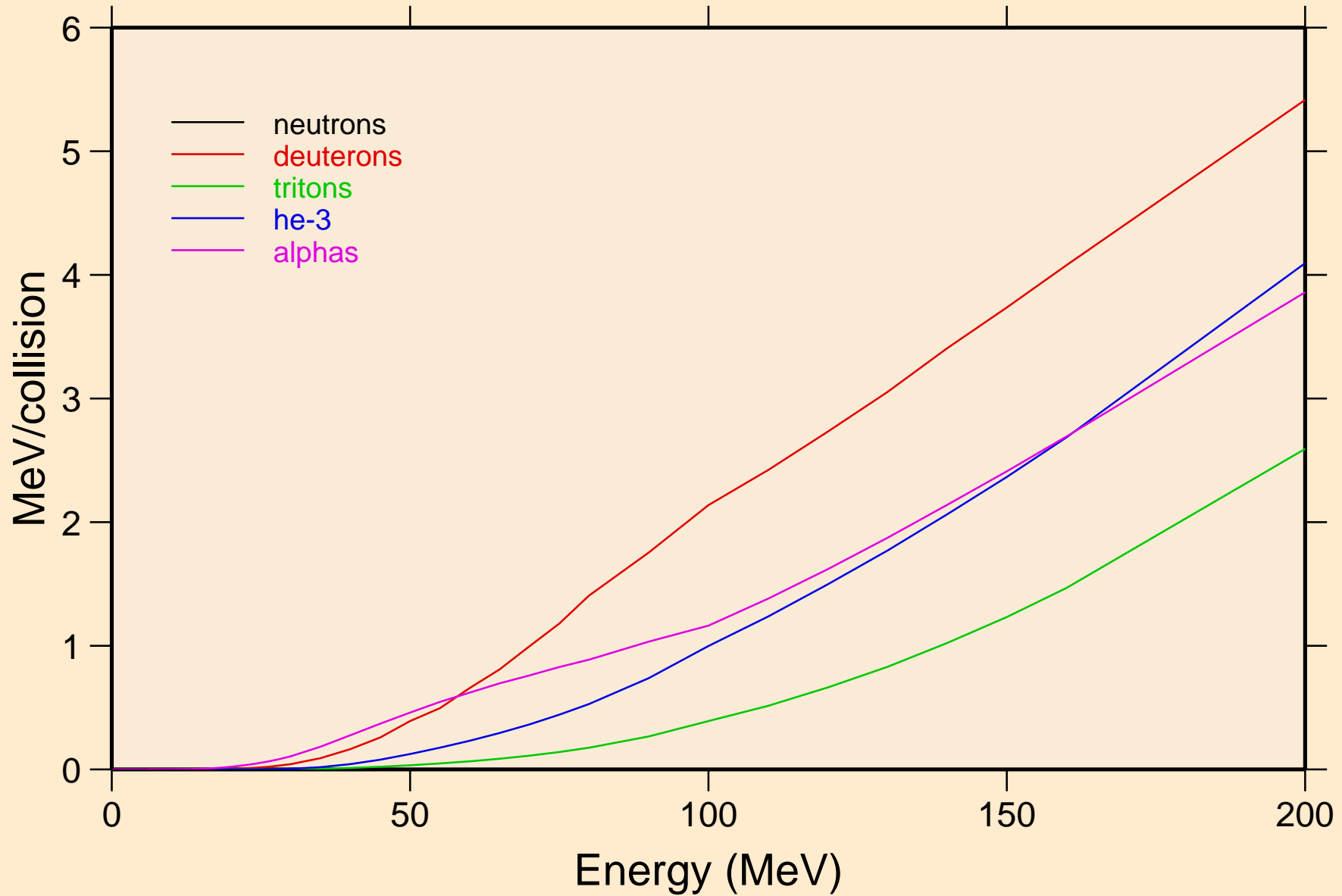

PD101 PROTON ACER TENDL-2024 LIBRARY; T=0.K  
Recoil Heating

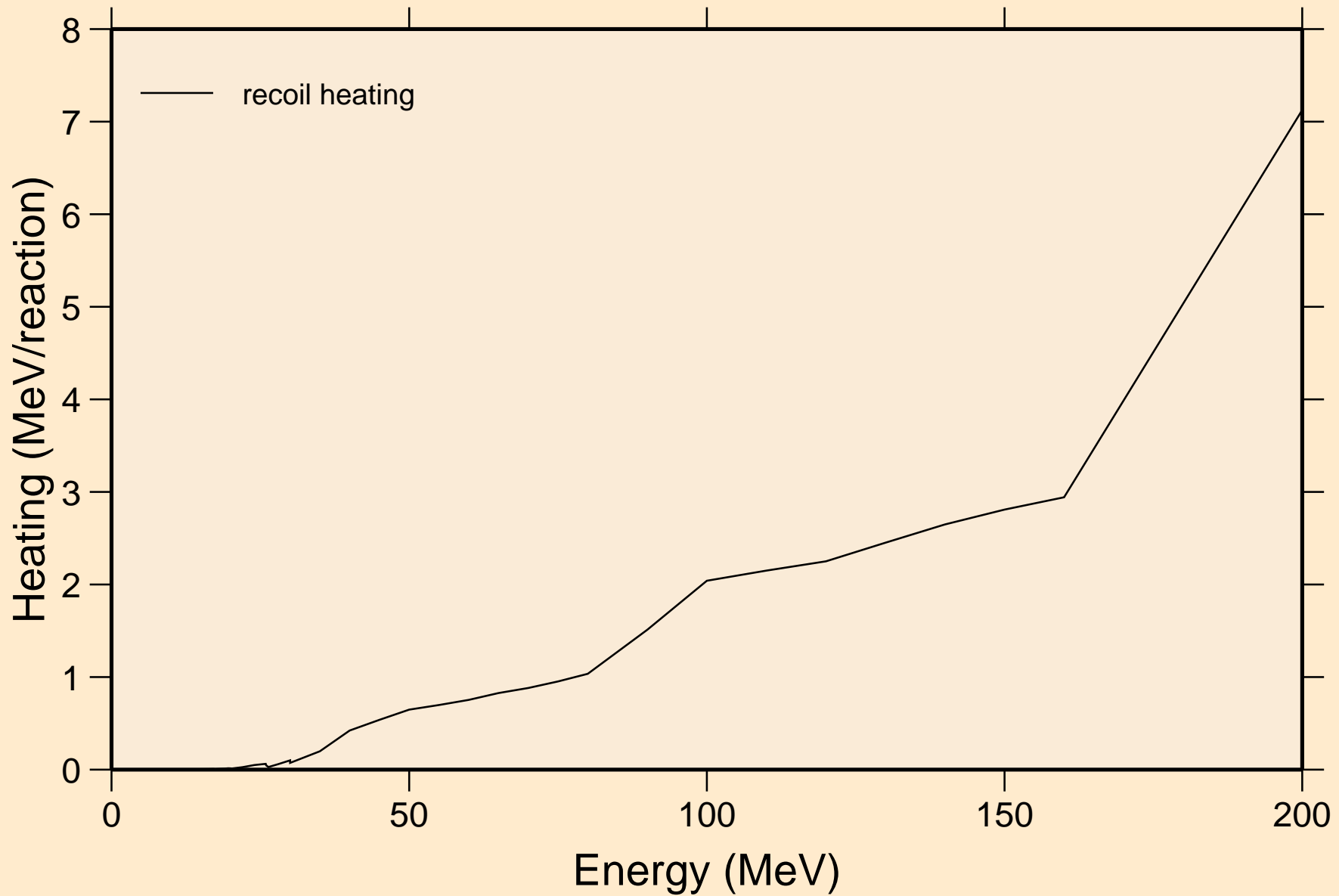

PD101 PROTON ACER TENDL-2024 LIBRARY; T=0.K  
Particle production cross sections

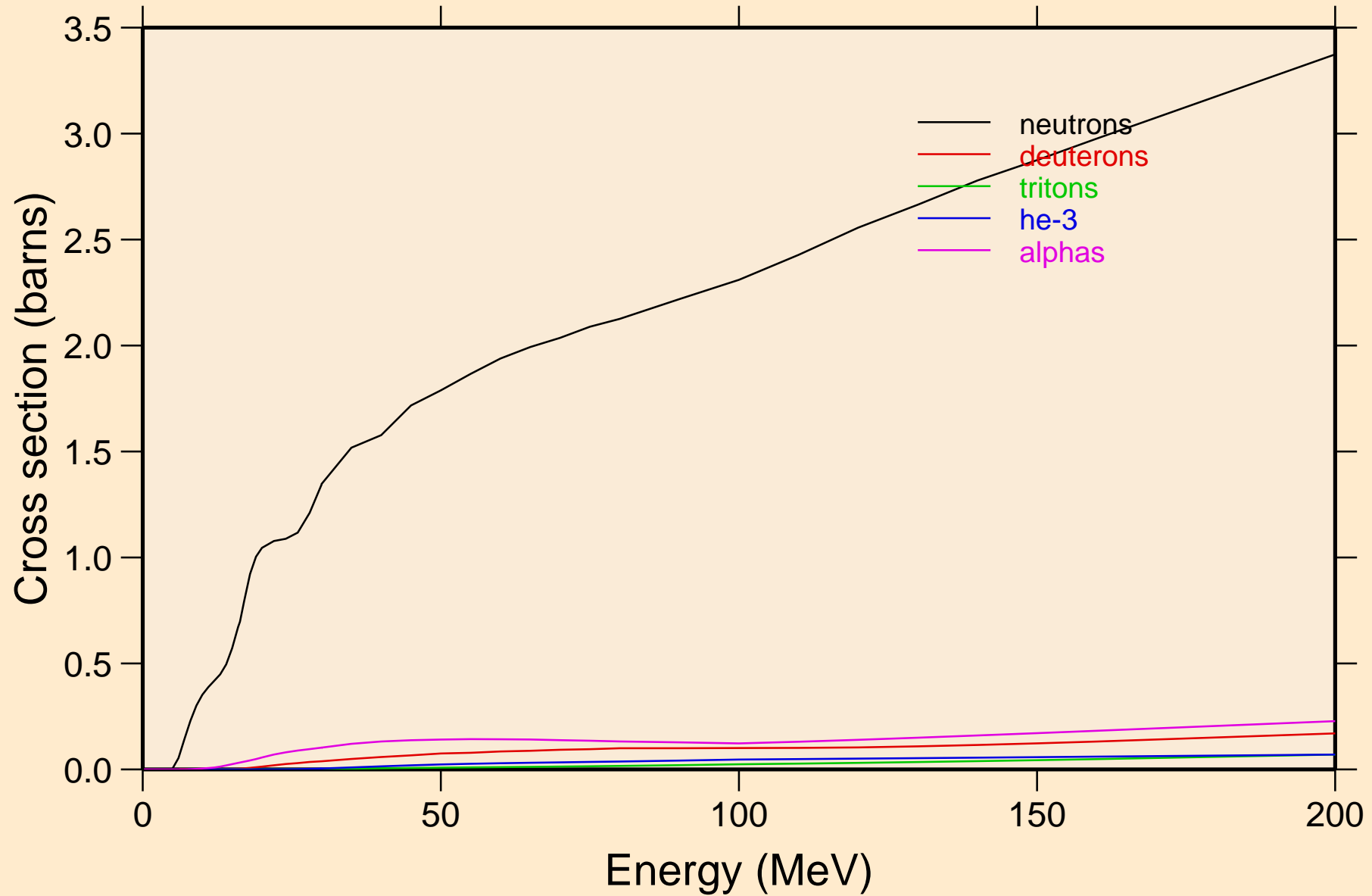

PD101 PROTON ACER TENDL-2024 LIBRARY; T=0.K  
neutrons from (p,n)

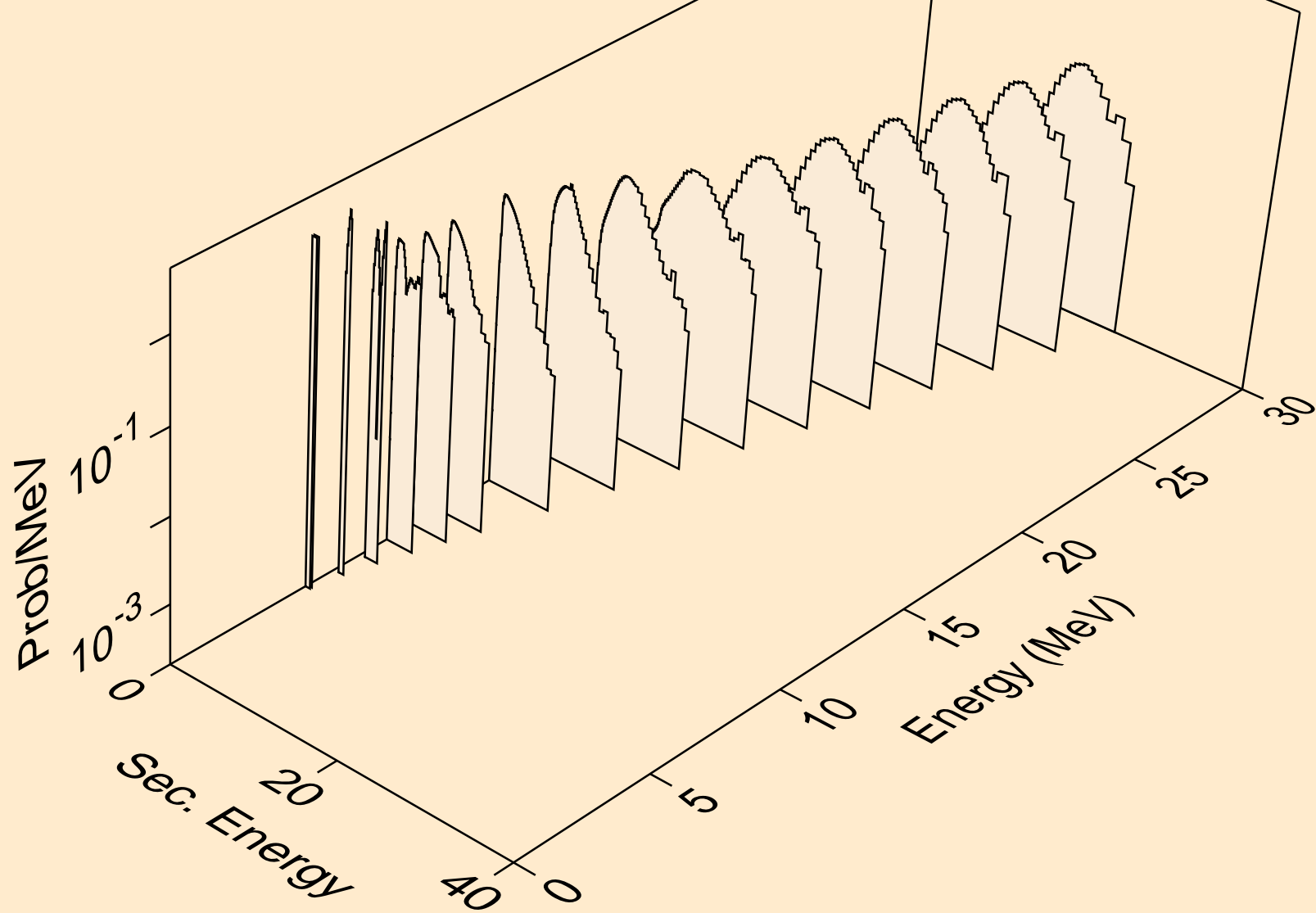

PD101 PROTON ACER TENDL-2024 LIBRARY; T=0.K  
neutrons from (p,x)

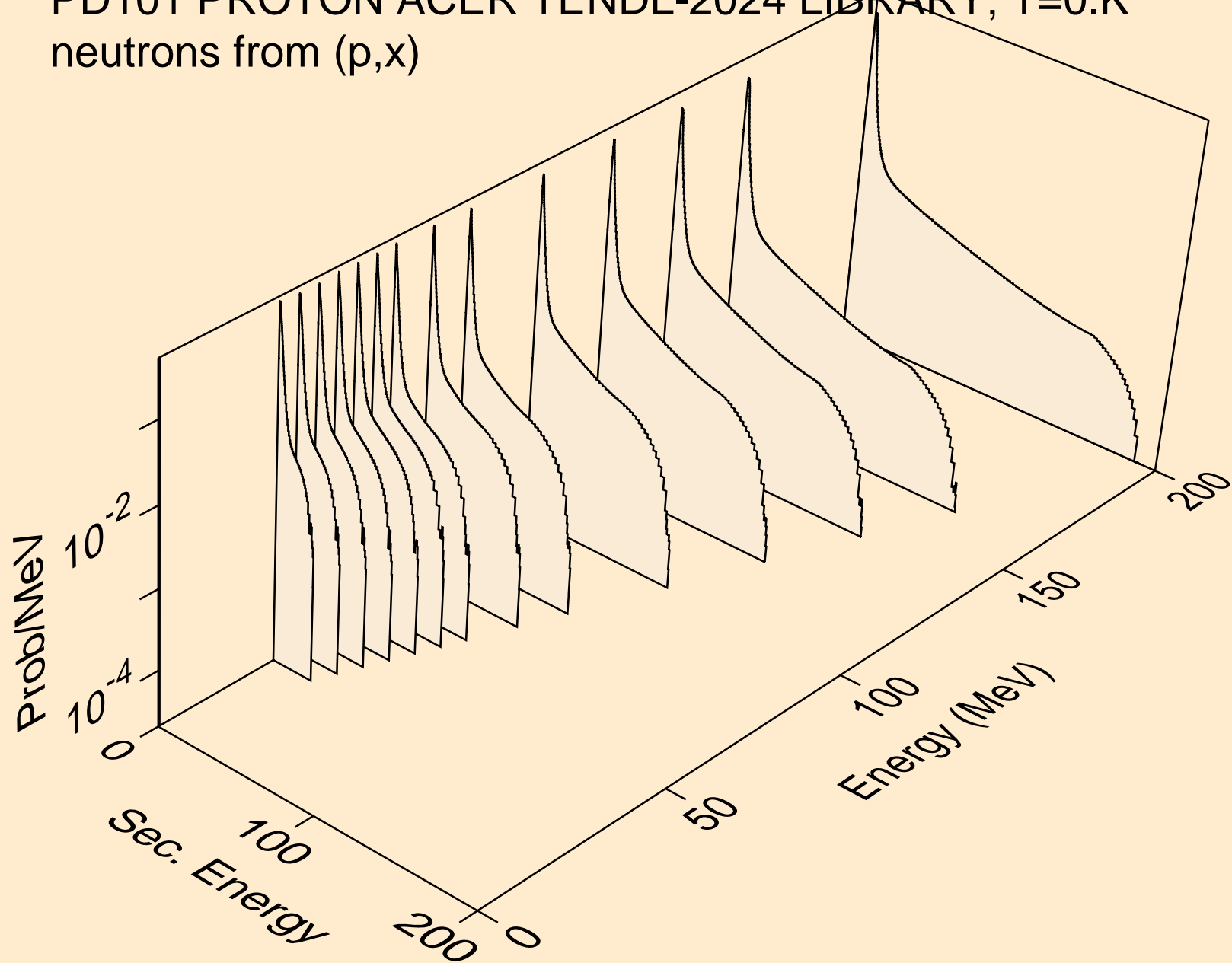

PD101 PROTON ACER TENDL-2024 LIBRARY; T=0.K  
neutrons from (p,2nd)

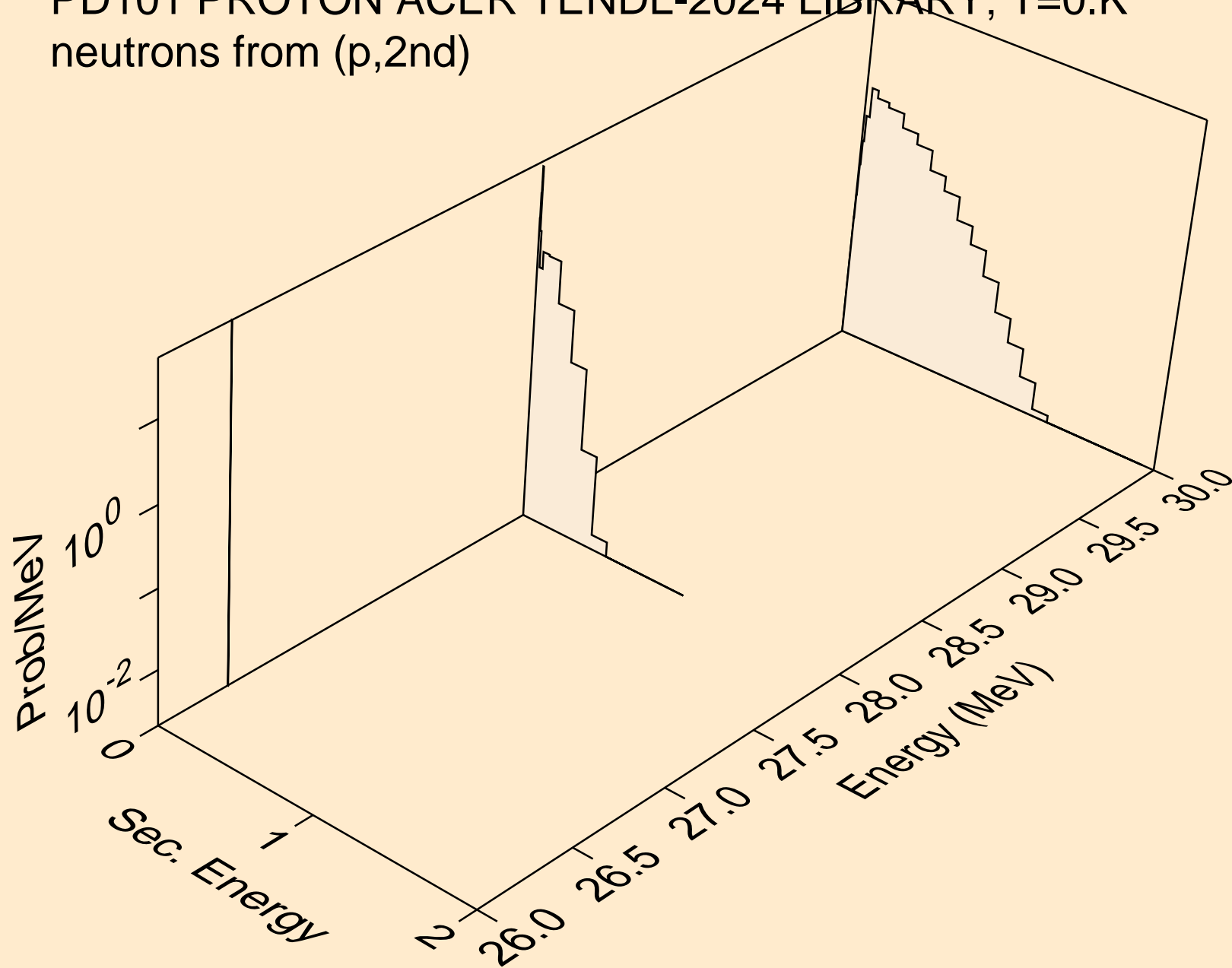

PD101 PROTON ACER TENDL-2024 LIBRARY; T=0.K  
neutrons from (p,2n)

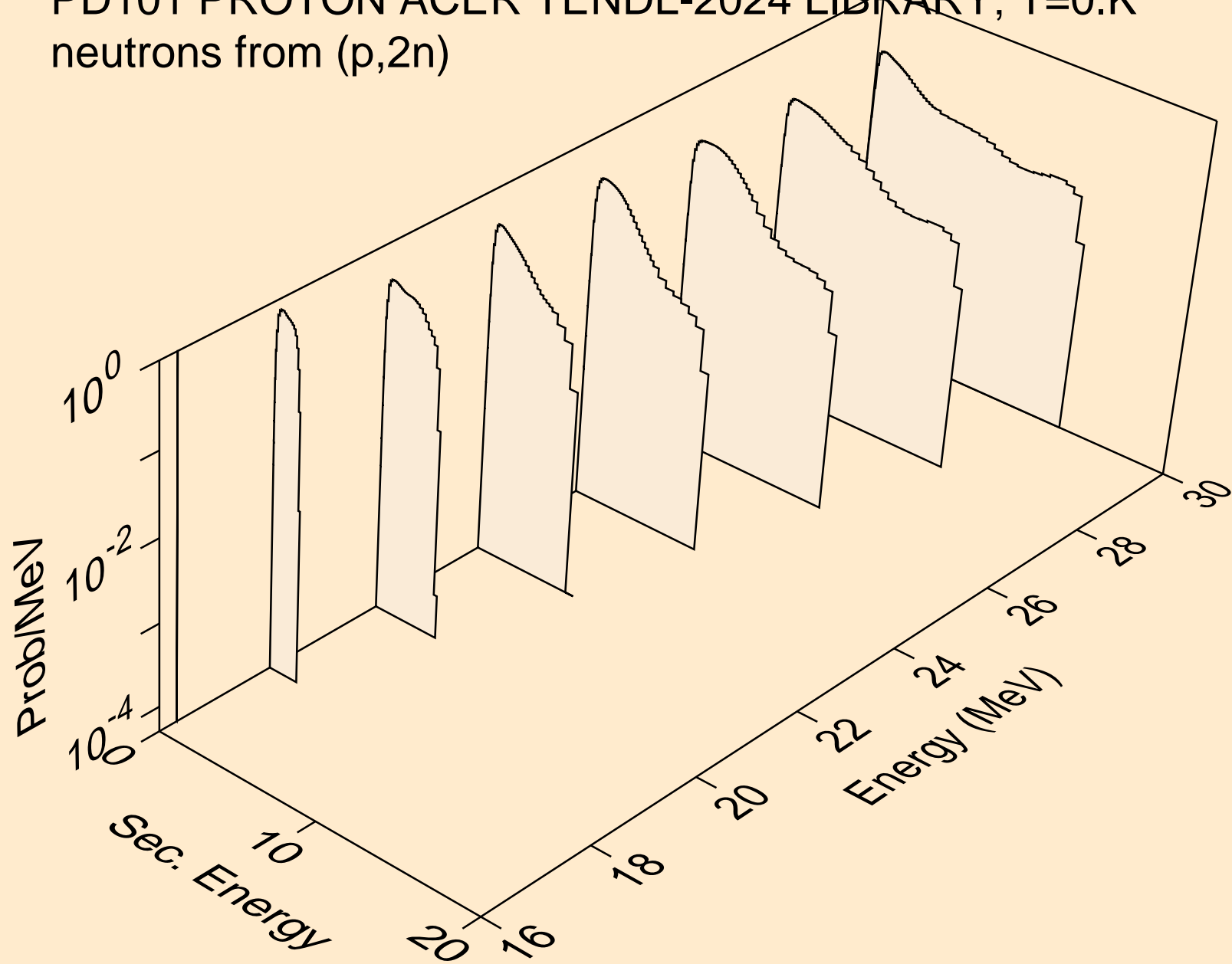

PD101 PROTON ACER TENDL-2024 LIBRARY; T=0.K  
neutrons from (p,3n)

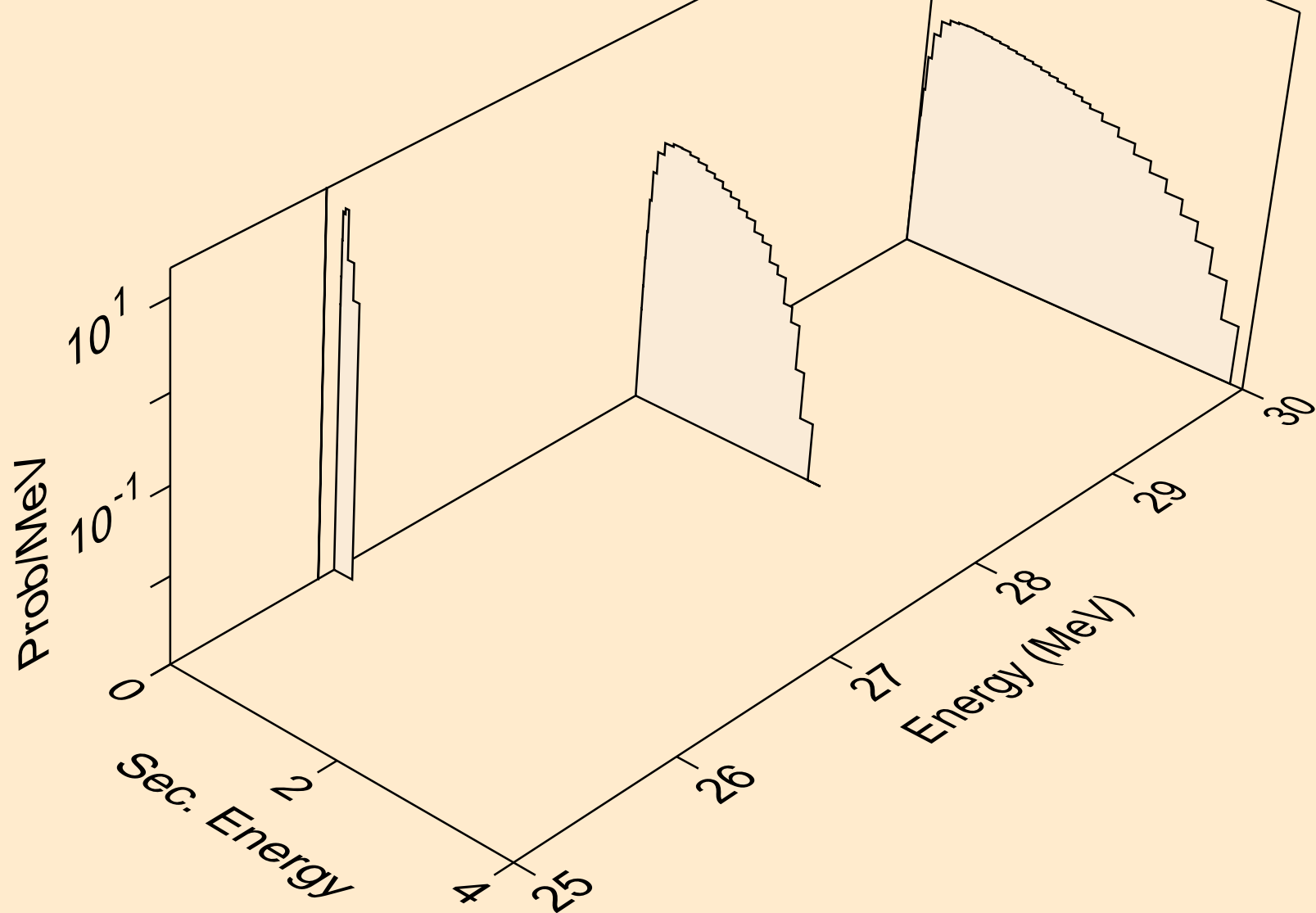

PD101 PROTON ACER TENDL-2024 LIBRARY; T=0.K  
neutrons from (p,n\*)a

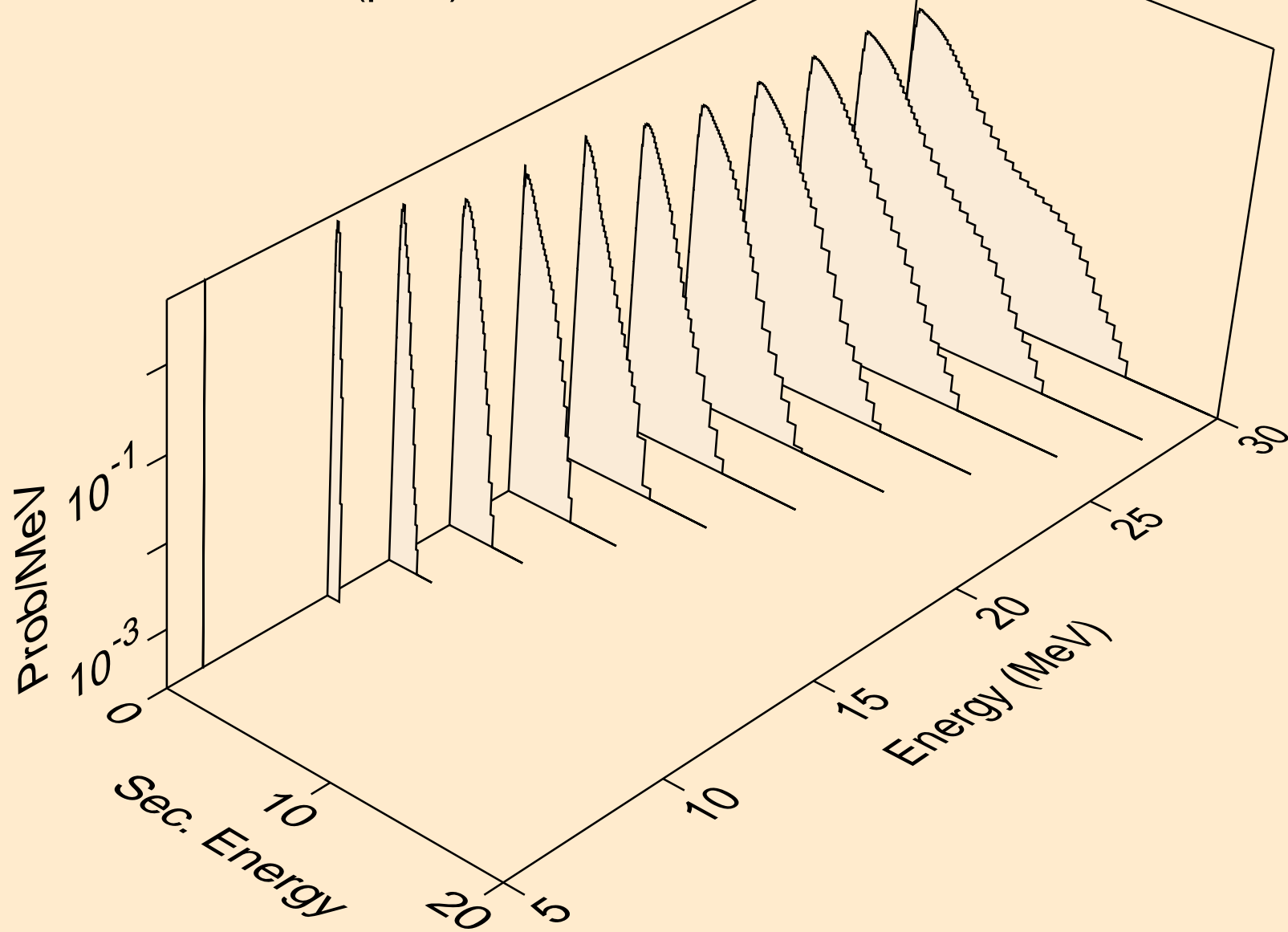

PD101 PROTON ACER TENDL-2024 LIBRARY; T=0.K  
neutrons from (p,2n)a

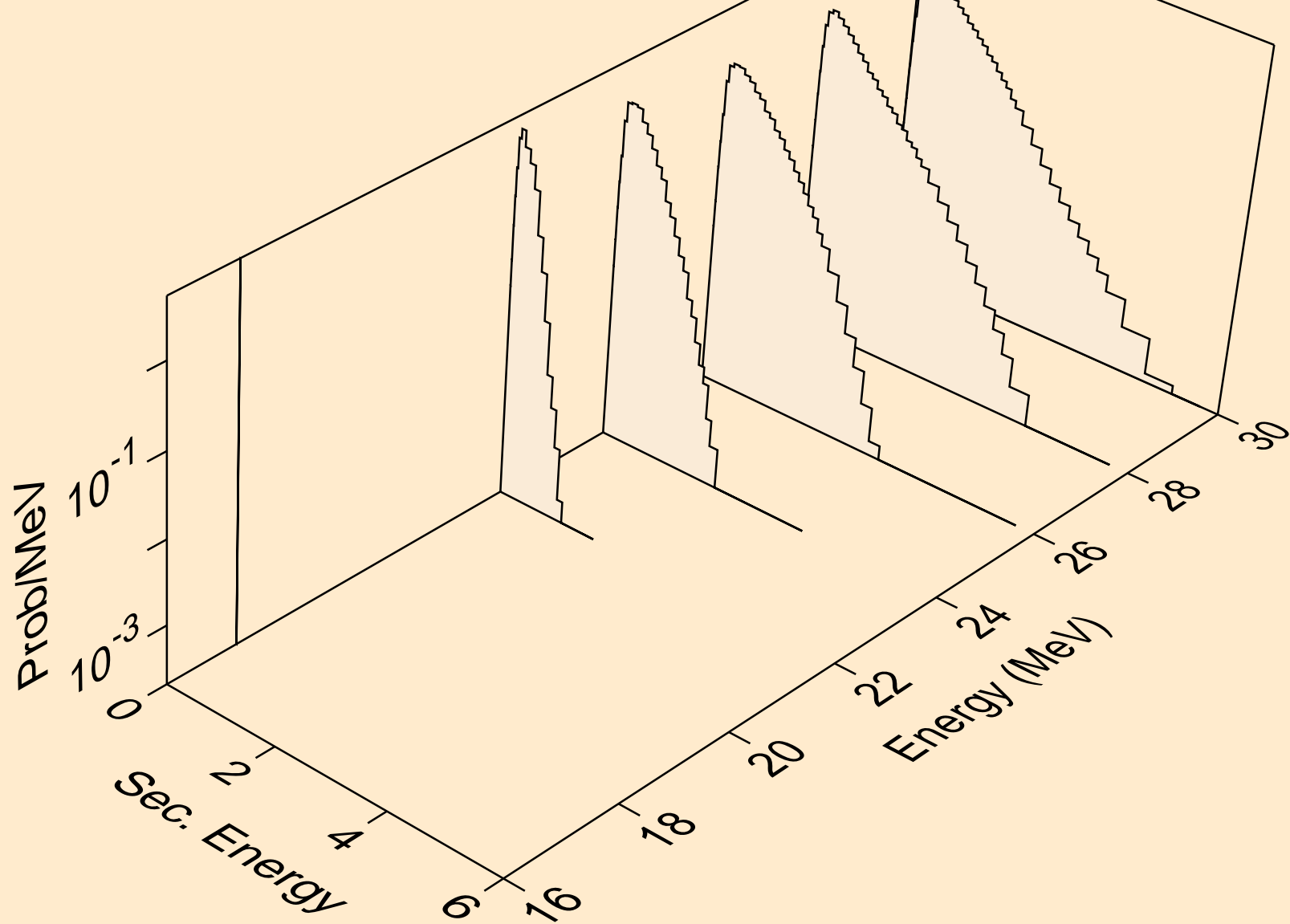

PD101 PROTON ACER TENDL-2024 LIBRARY; T=0.K  
neutrons from (p,n\*)p



PD101 PROTON ACER TENDL-2024 LIBRARY; T=0.K  
neutrons from (p,n\*)2a

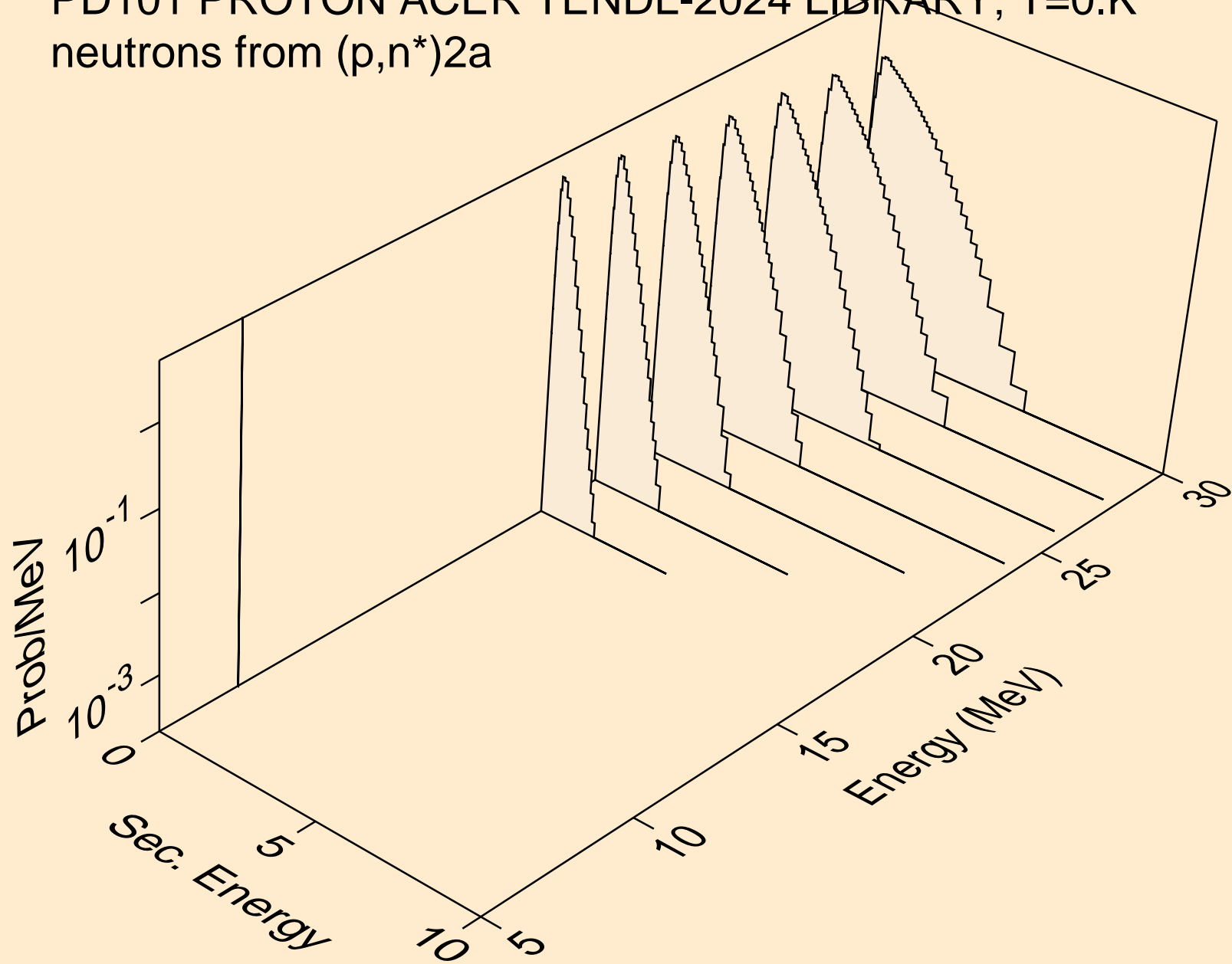

PD101 PROTON ACER TENDL-2024 LIBRARY; T=0.K  
neutrons from (p,n\*)d

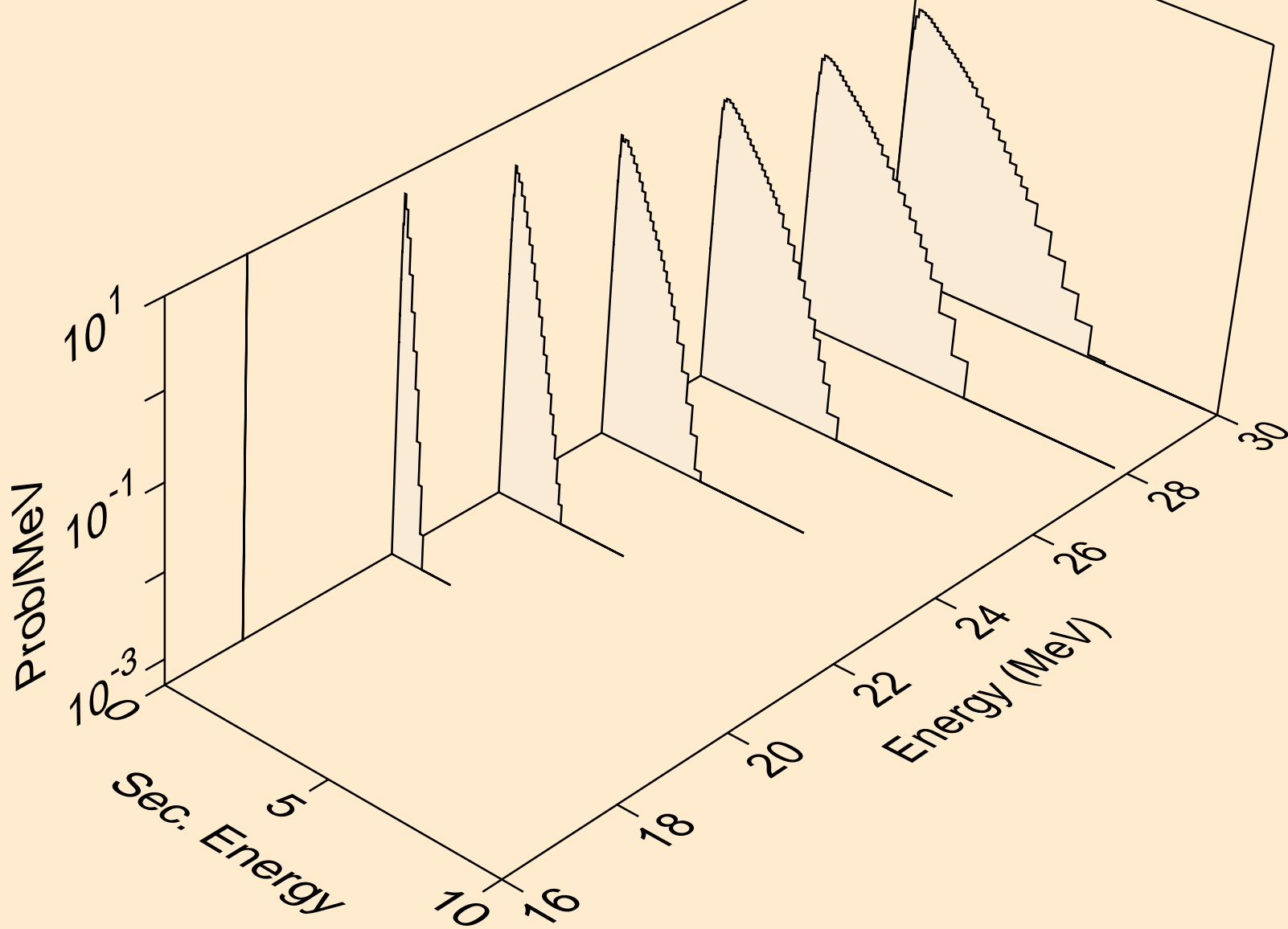

PD101 PROTON ACER TENDL-2024 LIBRARY; T=0.K  
neutrons from (p,n\*)t

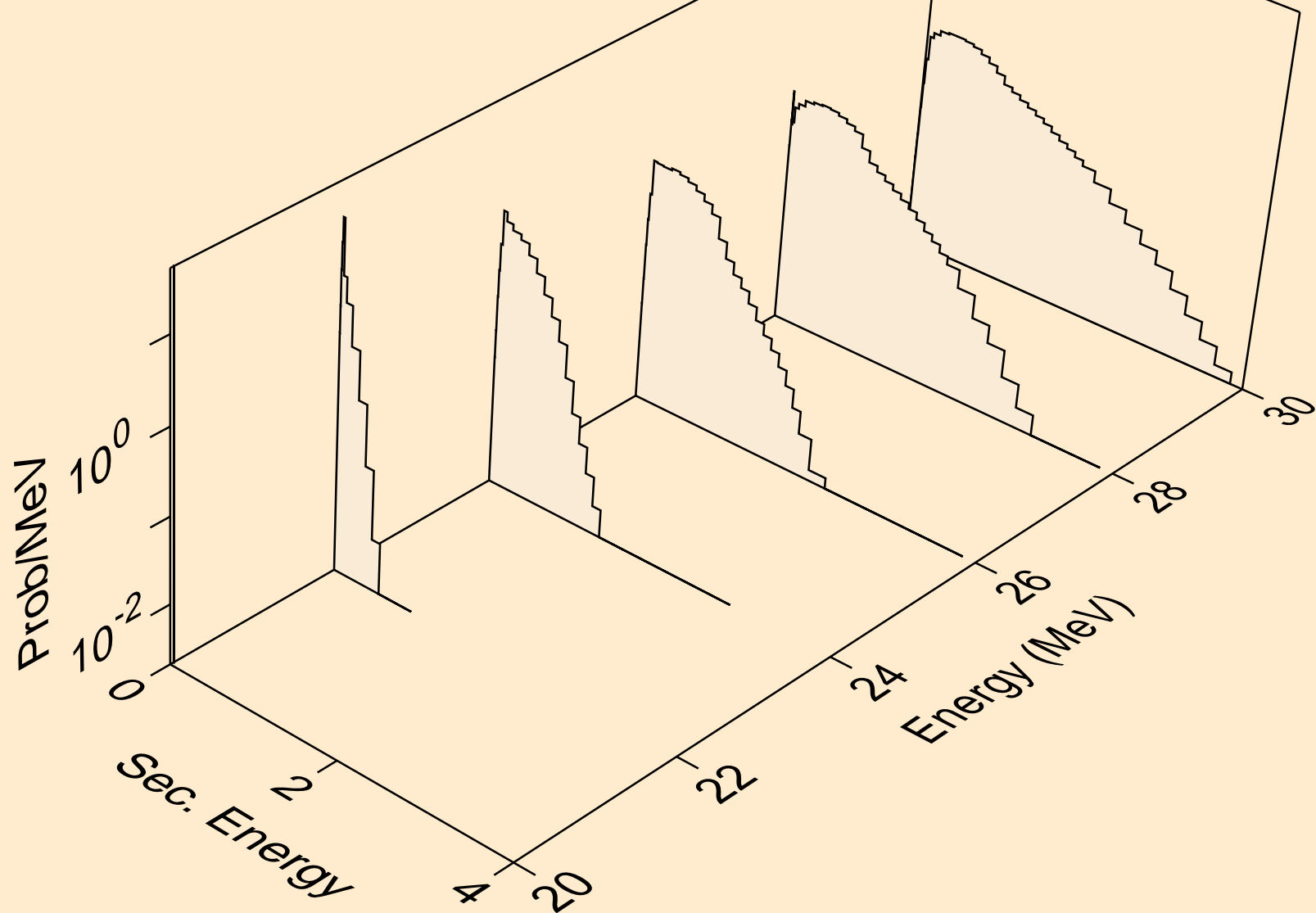

PD101 PROTON ACER TENDL-2024 LIBRARY; T=0.K  
neutrons from (p,n\*)he3

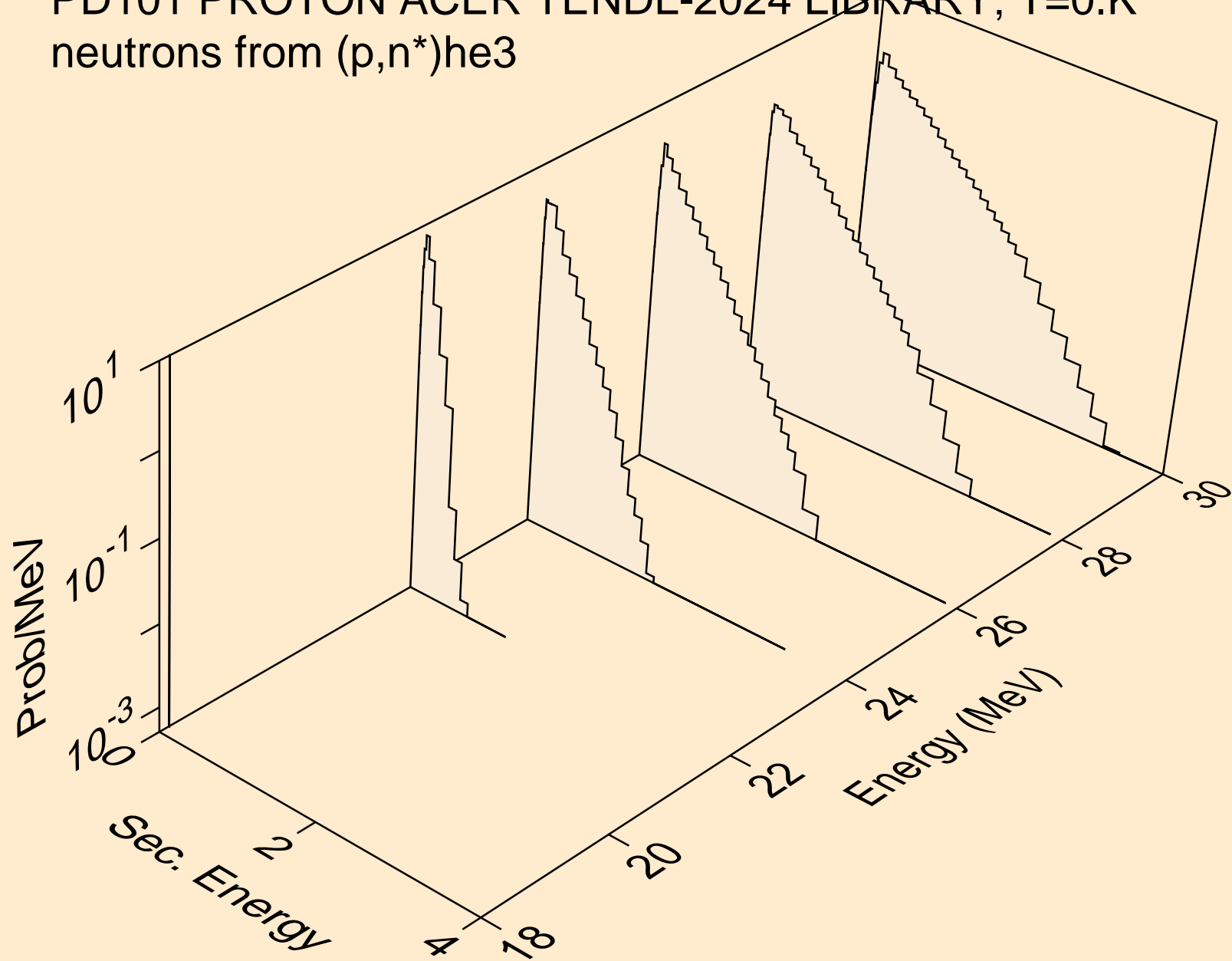

PD101 PROTON ACER TENDL-2024 LIBRARY; T=0.K  
neutrons from (p,2np)

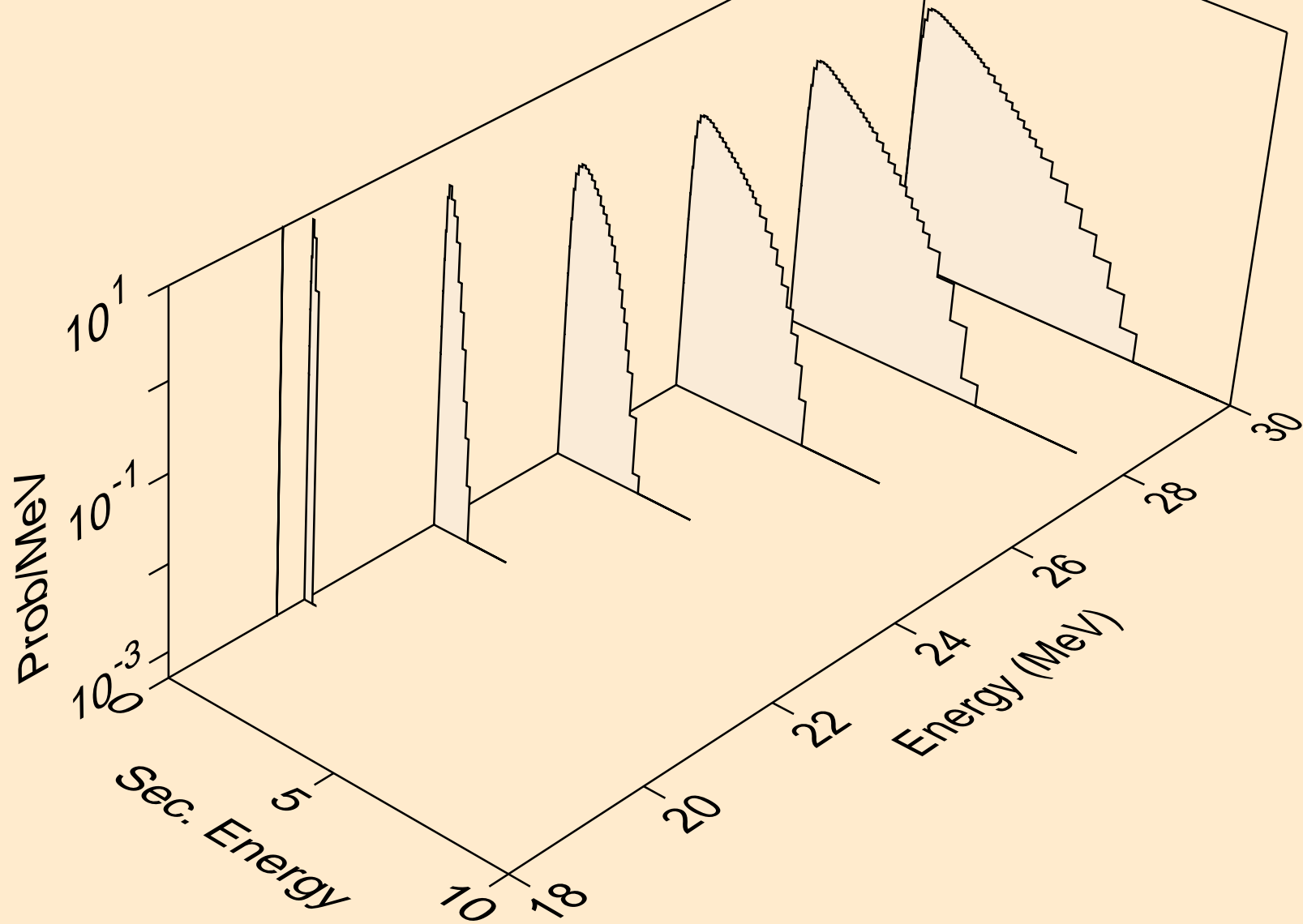

PD101 PROTON ACER TENDL-2024 LIBRARY; T=0.K  
neutrons from (p,n2p)



PD101 PROTON ACER TENDL-2024 LIBRARY; T=0.K  
neutrons from (p,npa)

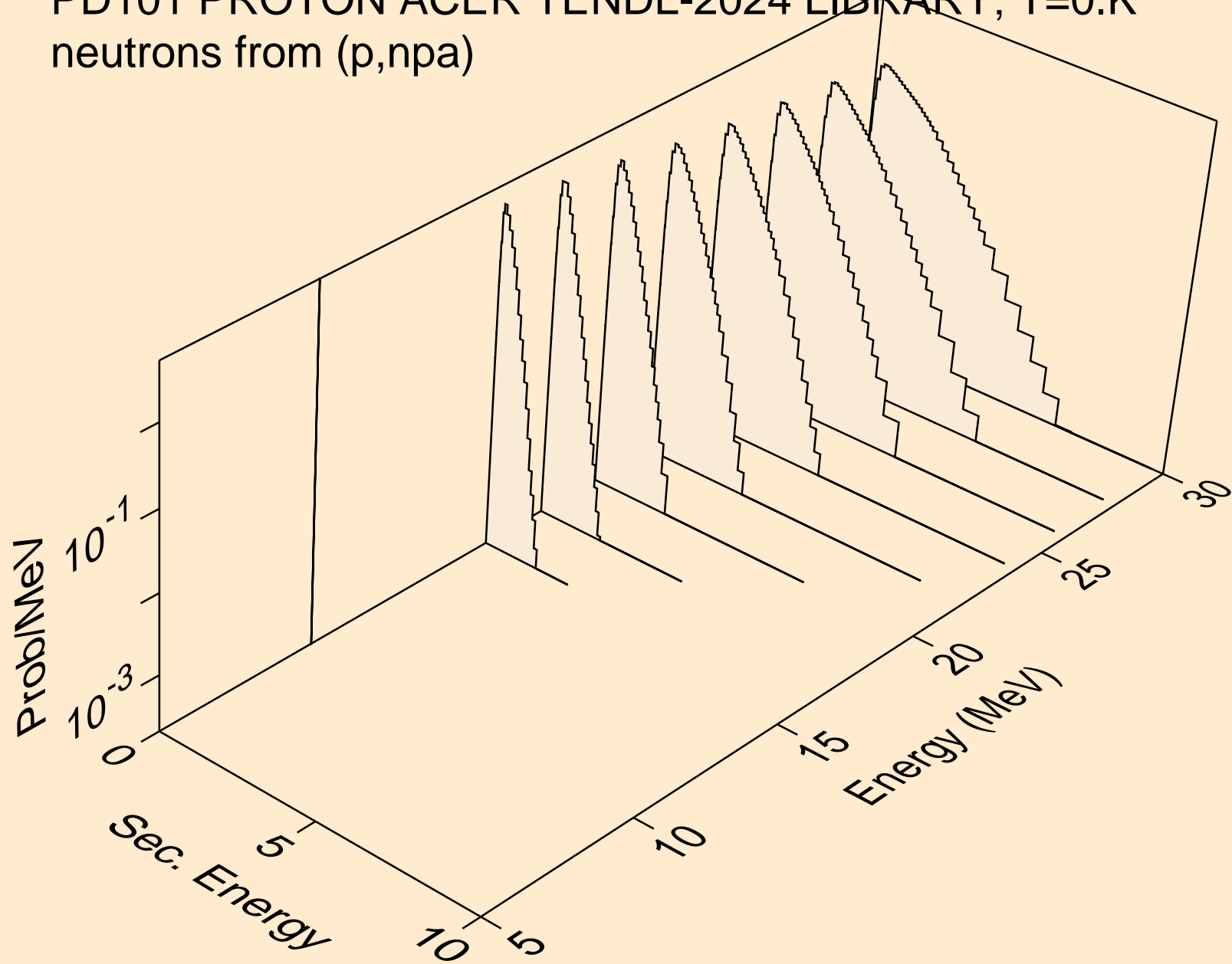

PD101 PROTON ACER TENDL-2024 LIBRARY; T=0.K  
deuterons from (p,x)

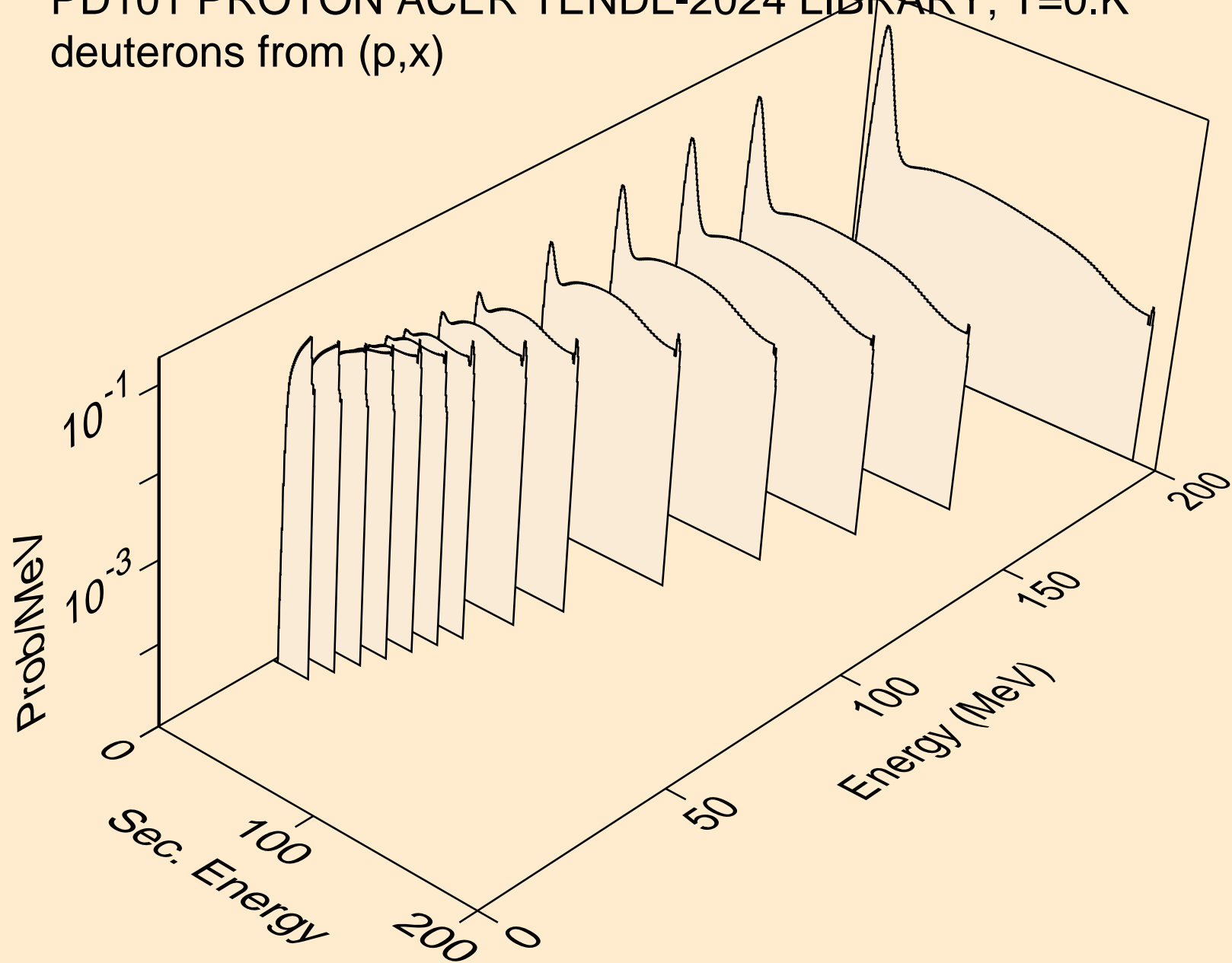

PD101 PROTON ACER TENDL-2024 LIBRARY; T=0.K  
deuterons from (p,2nd)

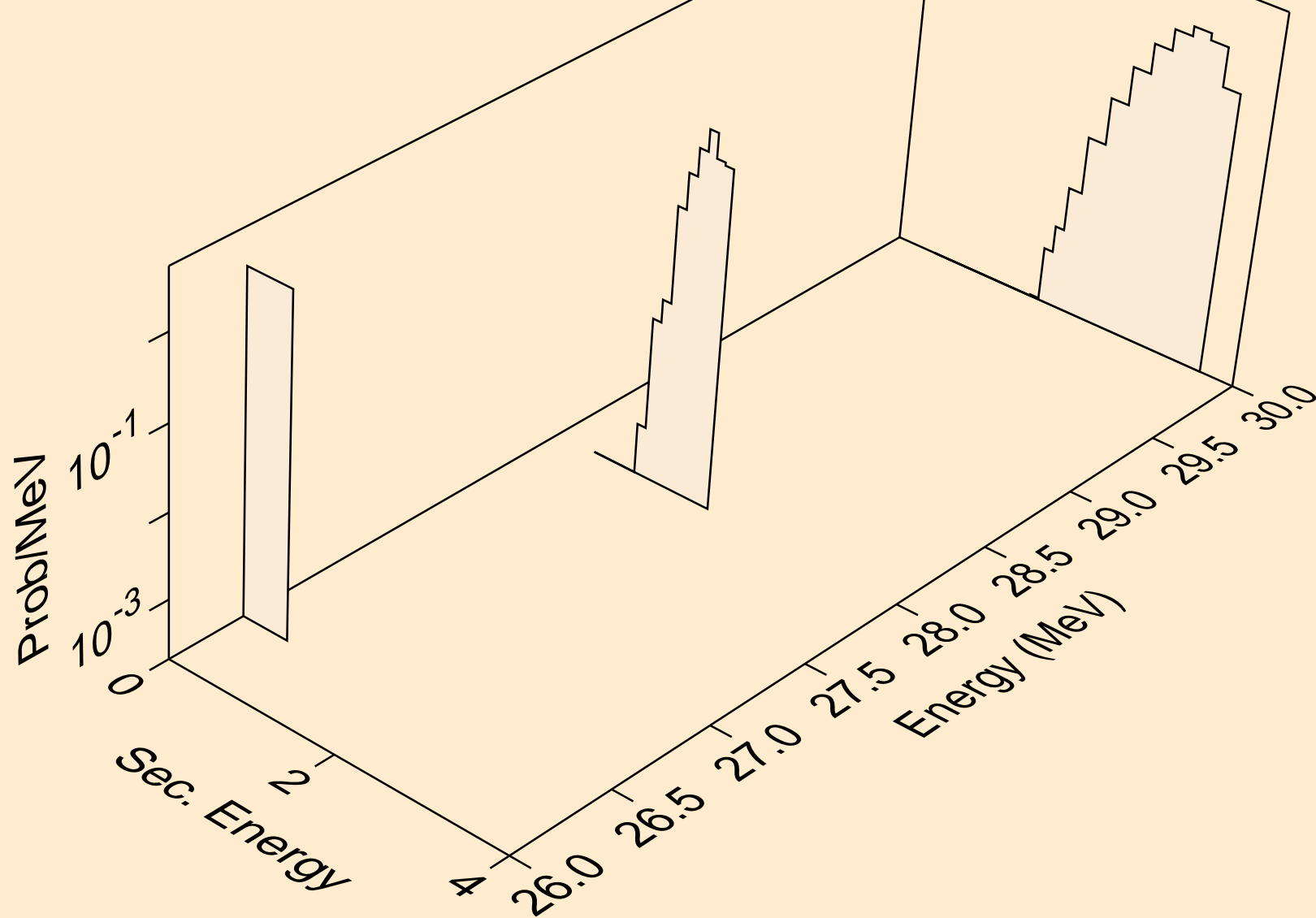

PD101 PROTON ACER TENDL-2024 LIBRARY; T=0.K  
deuterons from (p,n\*)d

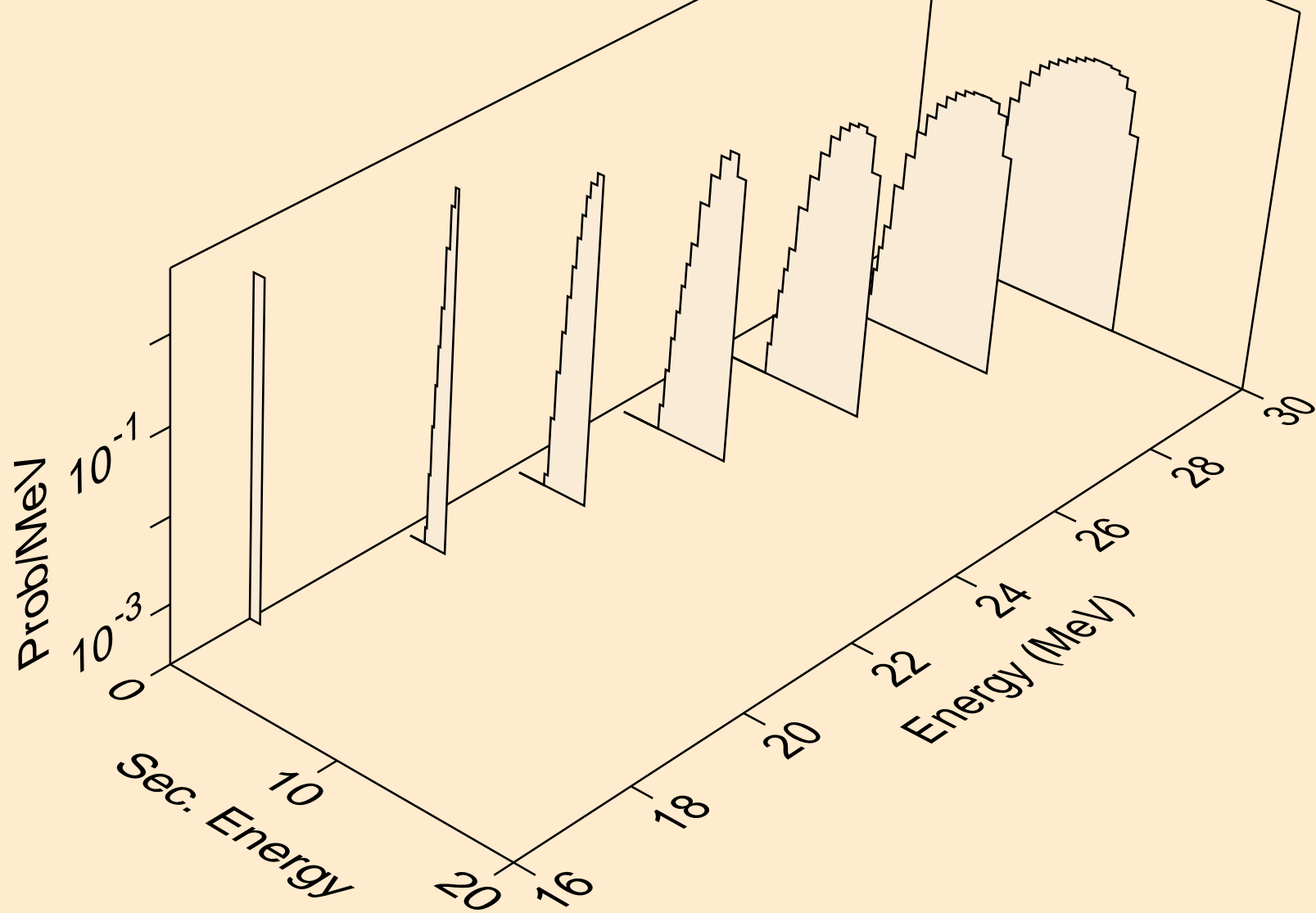

PD101 PROTON ACER TENDL-2024 LIBRARY; T=0.K  
deuterons from (p,d)

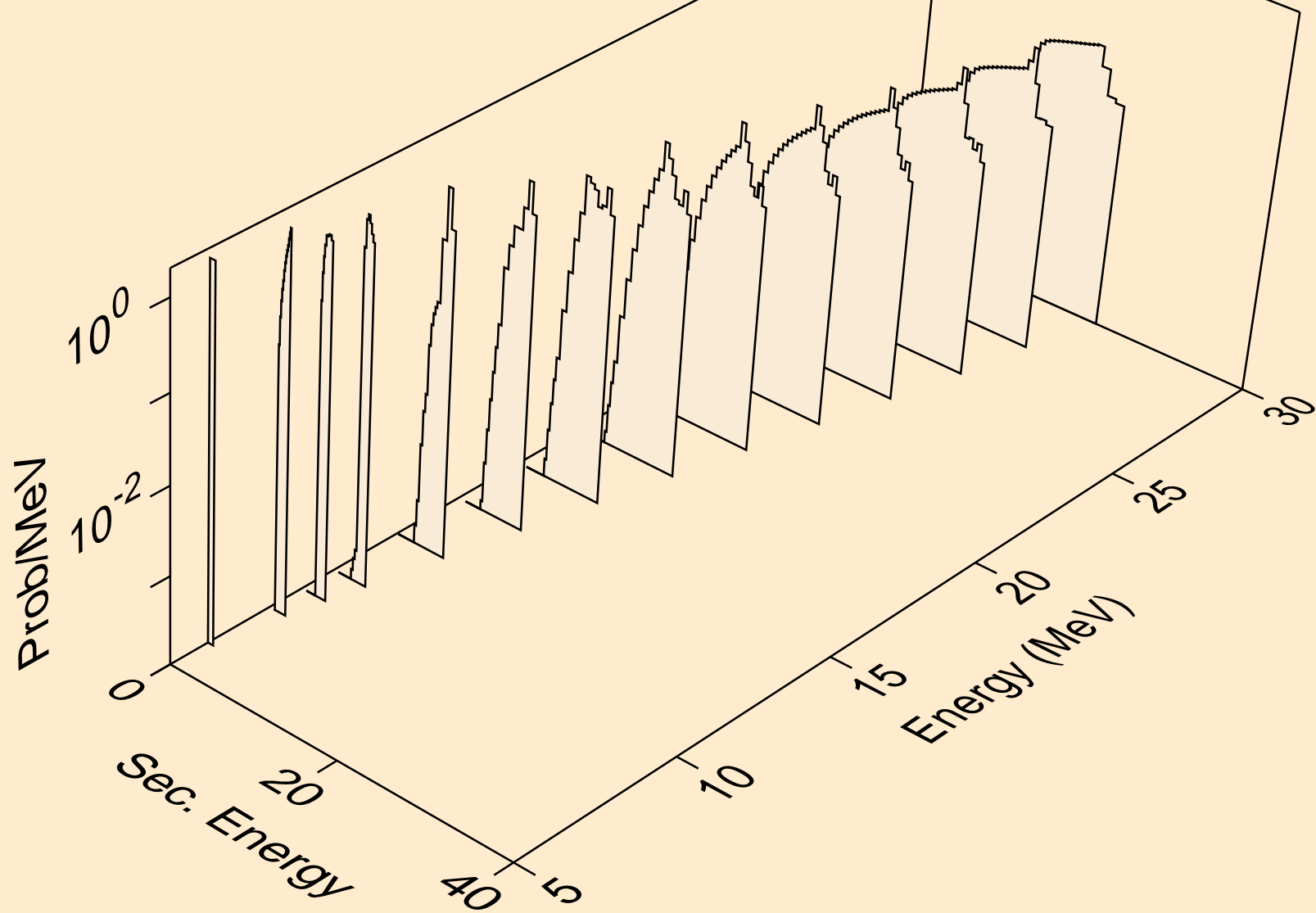

PD101 PROTON ACER TENDL-2024 LIBRARY; T=0.K  
deuterons from (p,pd)

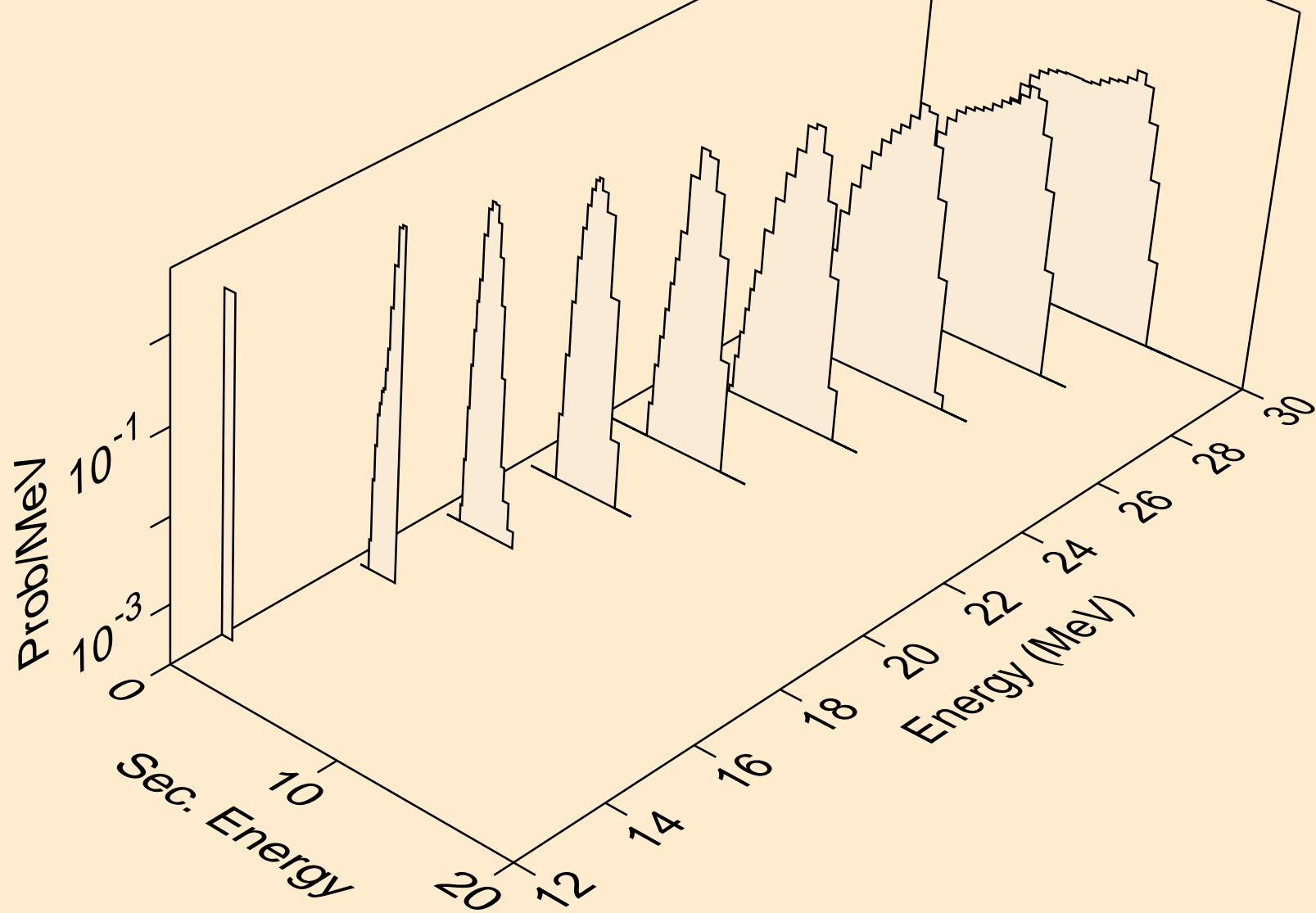

PD101 PROTON ACER TENDL-2024 LIBRARY; T=0.K  
deuterons from (p,da)

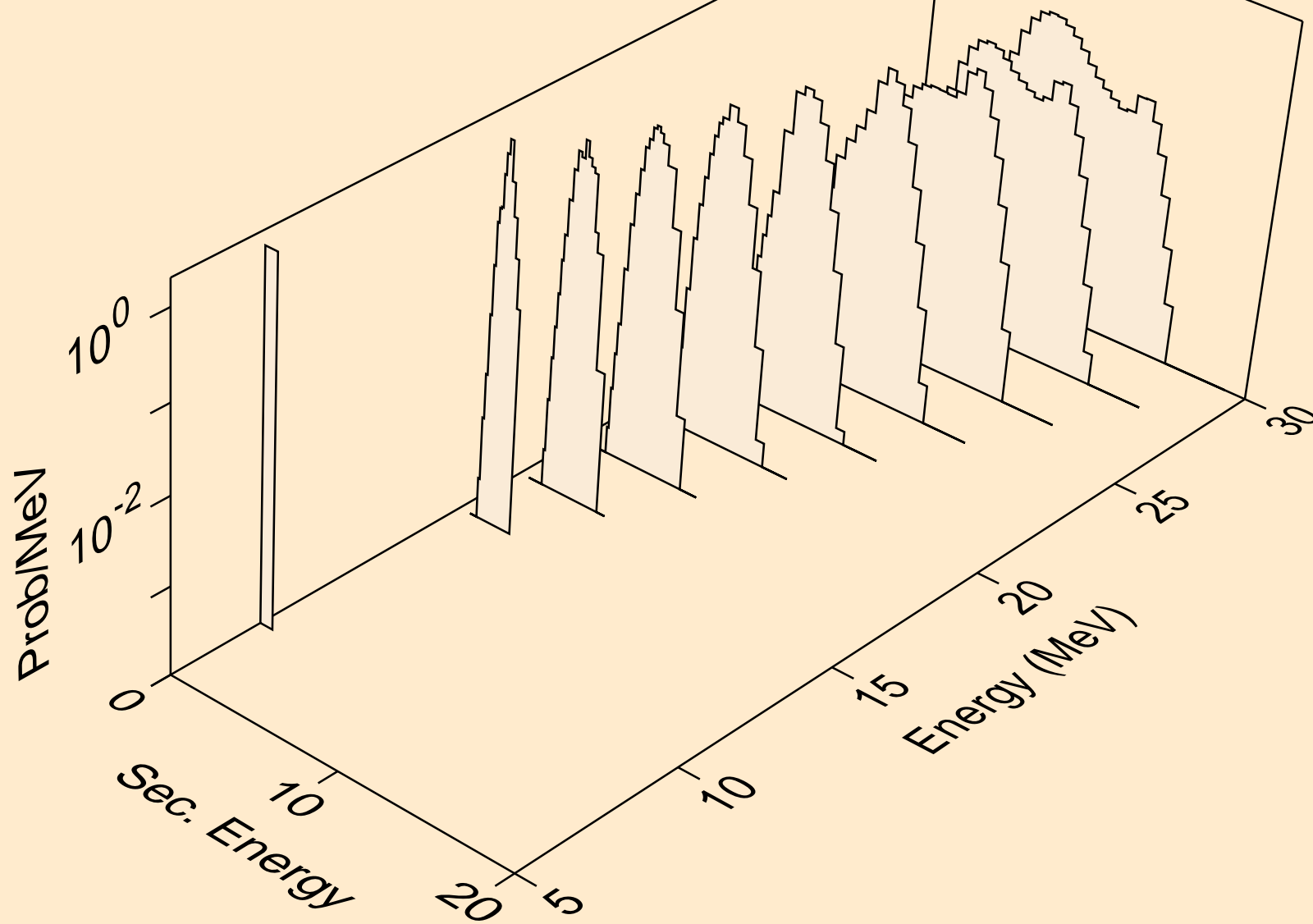

PD101 PROTON ACER TENDL-2024 LIBRARY; T=0.K  
tritons from (p,x)

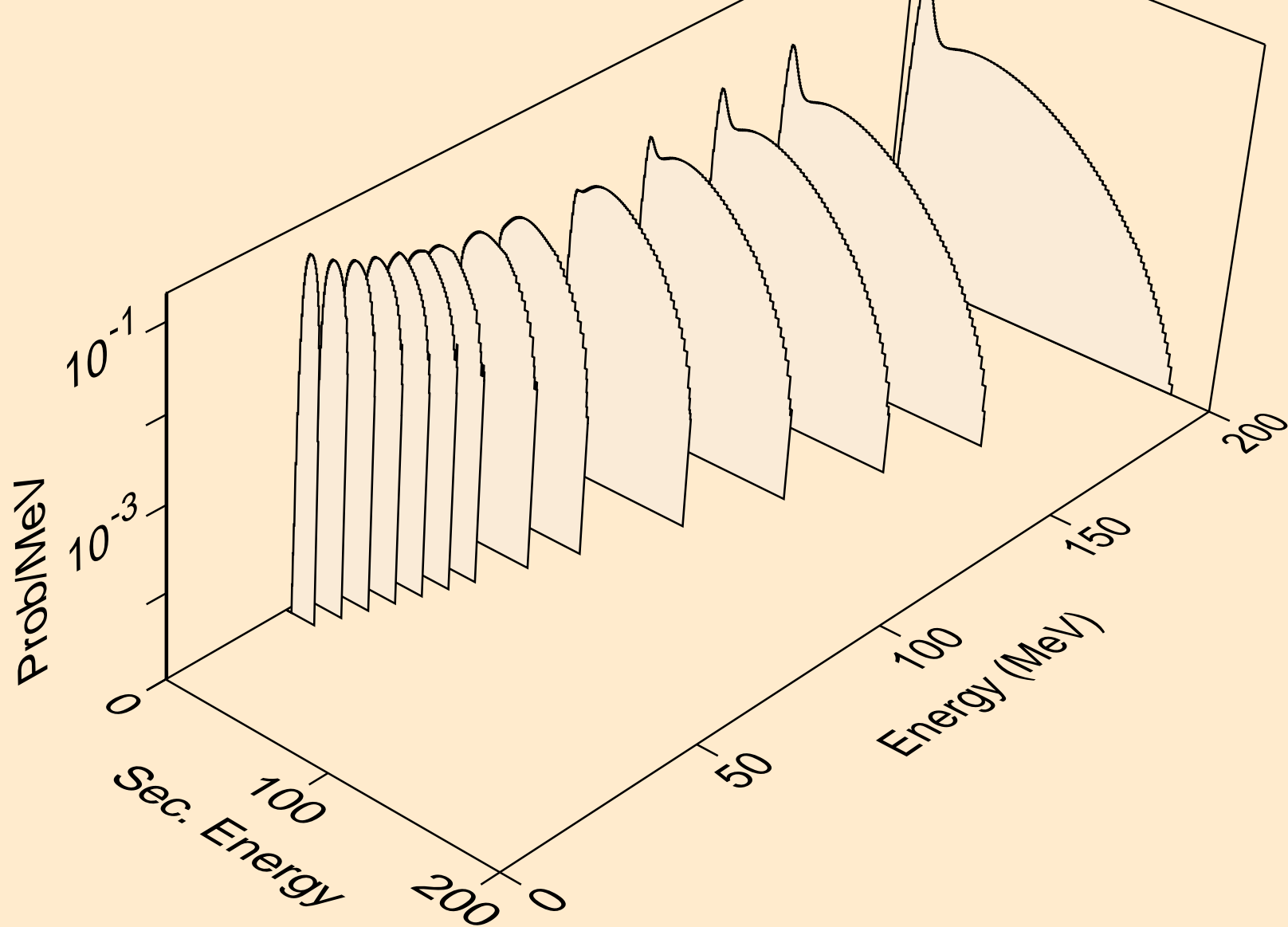

PD101 PROTON ACER TENDL-2024 LIBRARY; T=0.K  
tritons from (p,n\*)t

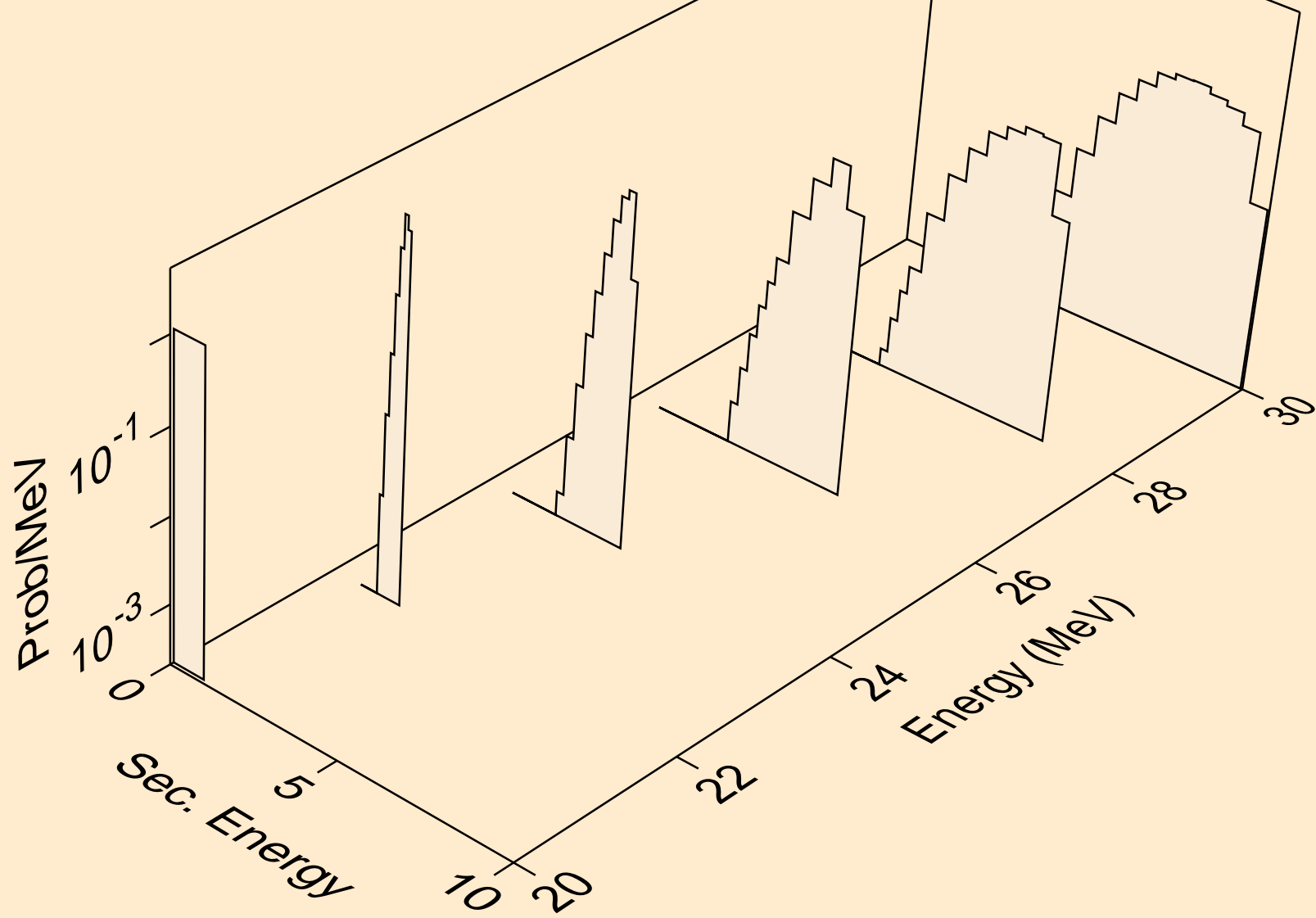

PD101 PROTON ACER TENDL-2024 LIBRARY; T=0.K  
tritons from (p,t)

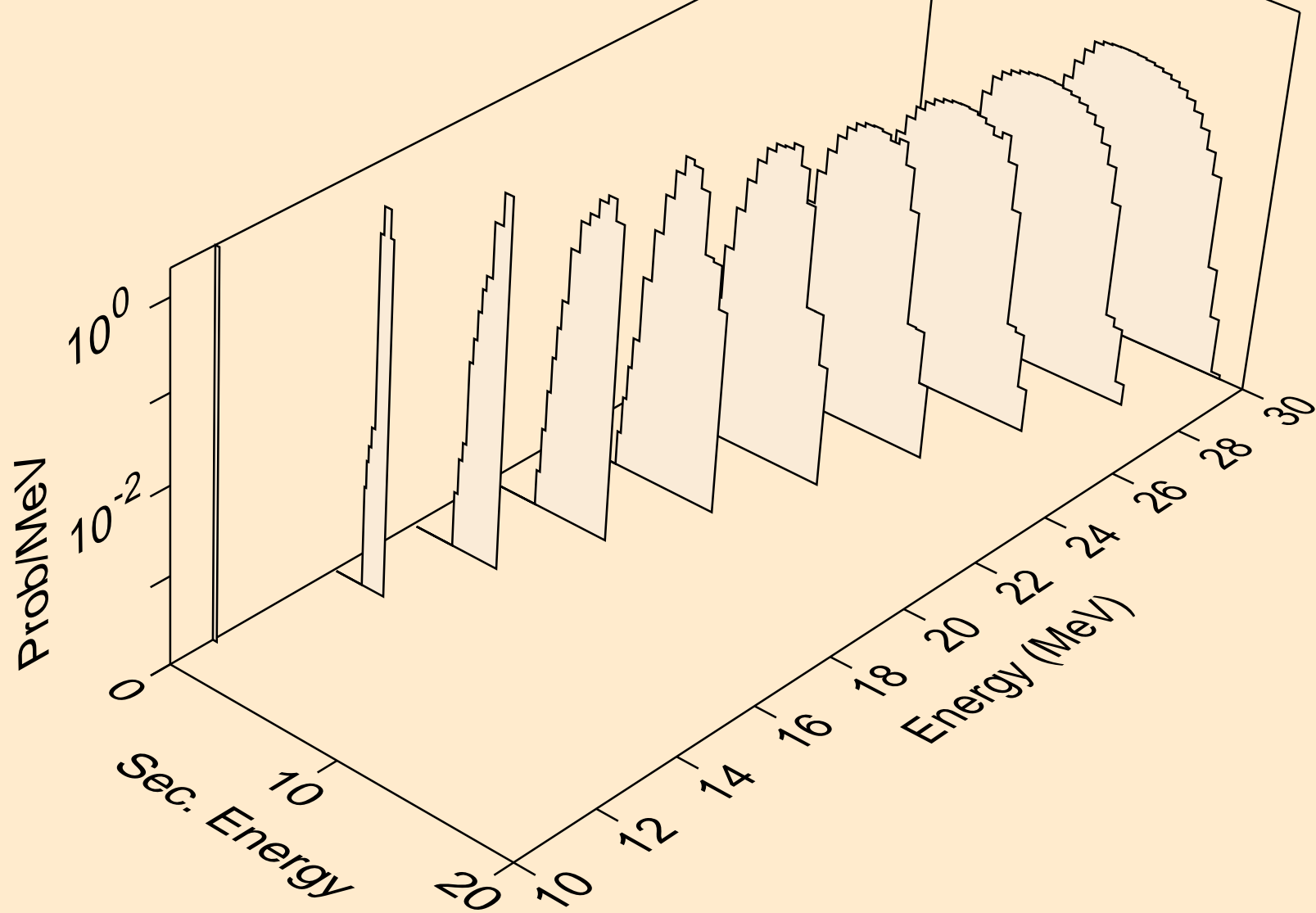

PD101 PROTON ACER TENDL-2024 LIBRARY; T=0.K  
tritons from (p,pt)

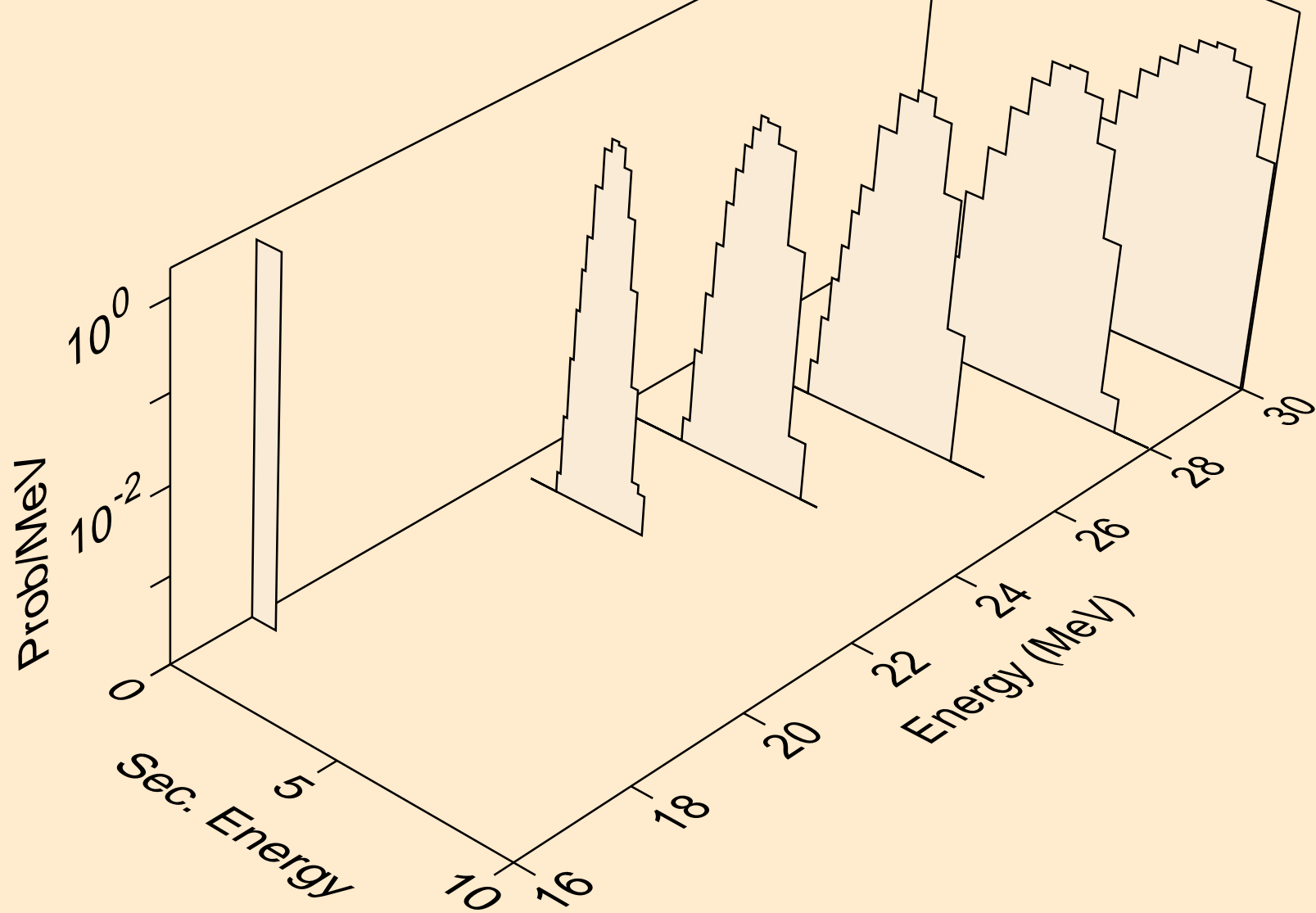

PD101 PROTON ACER TENDL-2024 LIBRARY; T=0.K  
he3s from (p,x)

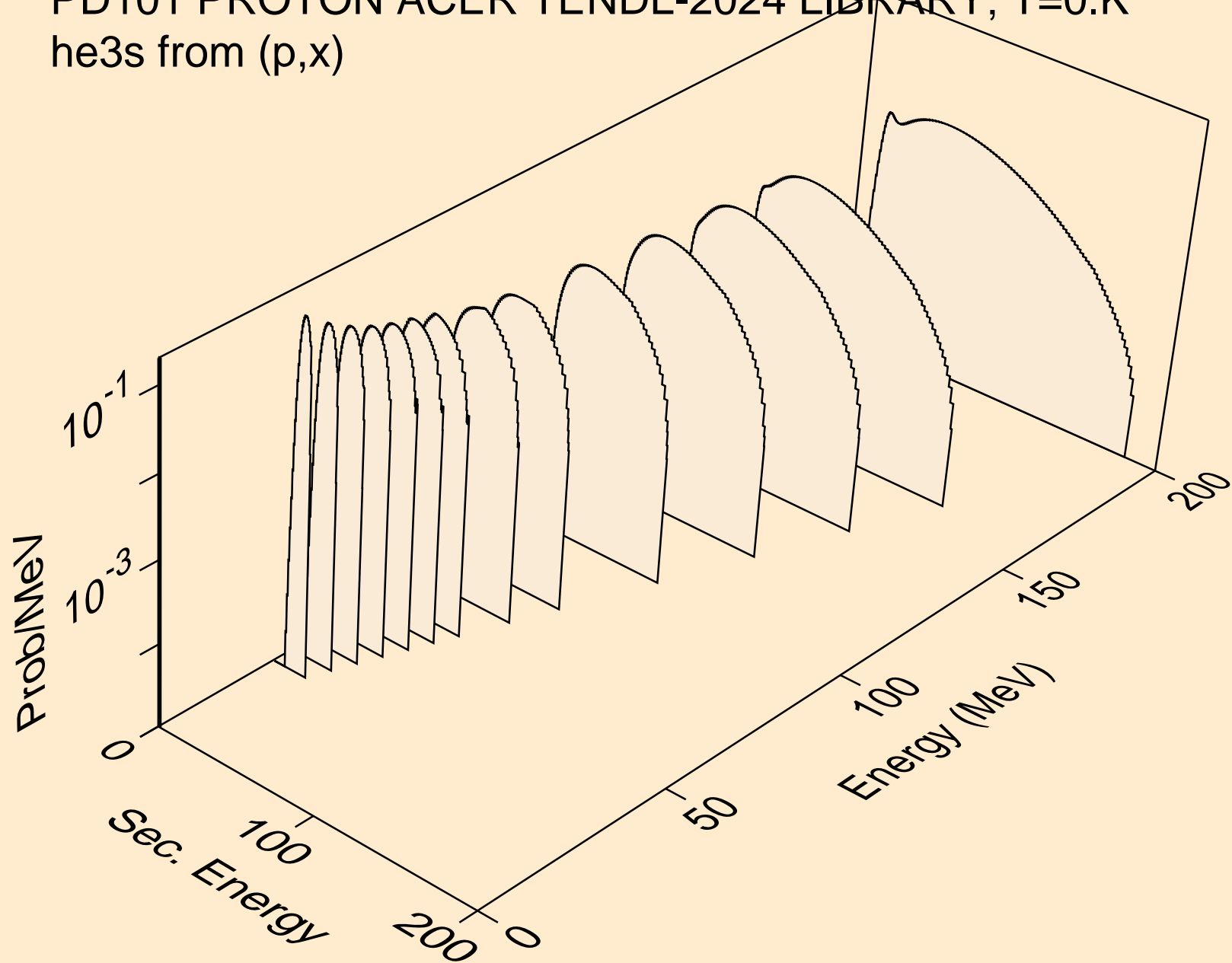

PD101 PROTON ACER TENDL-2024 LIBRARY; T=0.K  
he3s from (p,n\*)he3

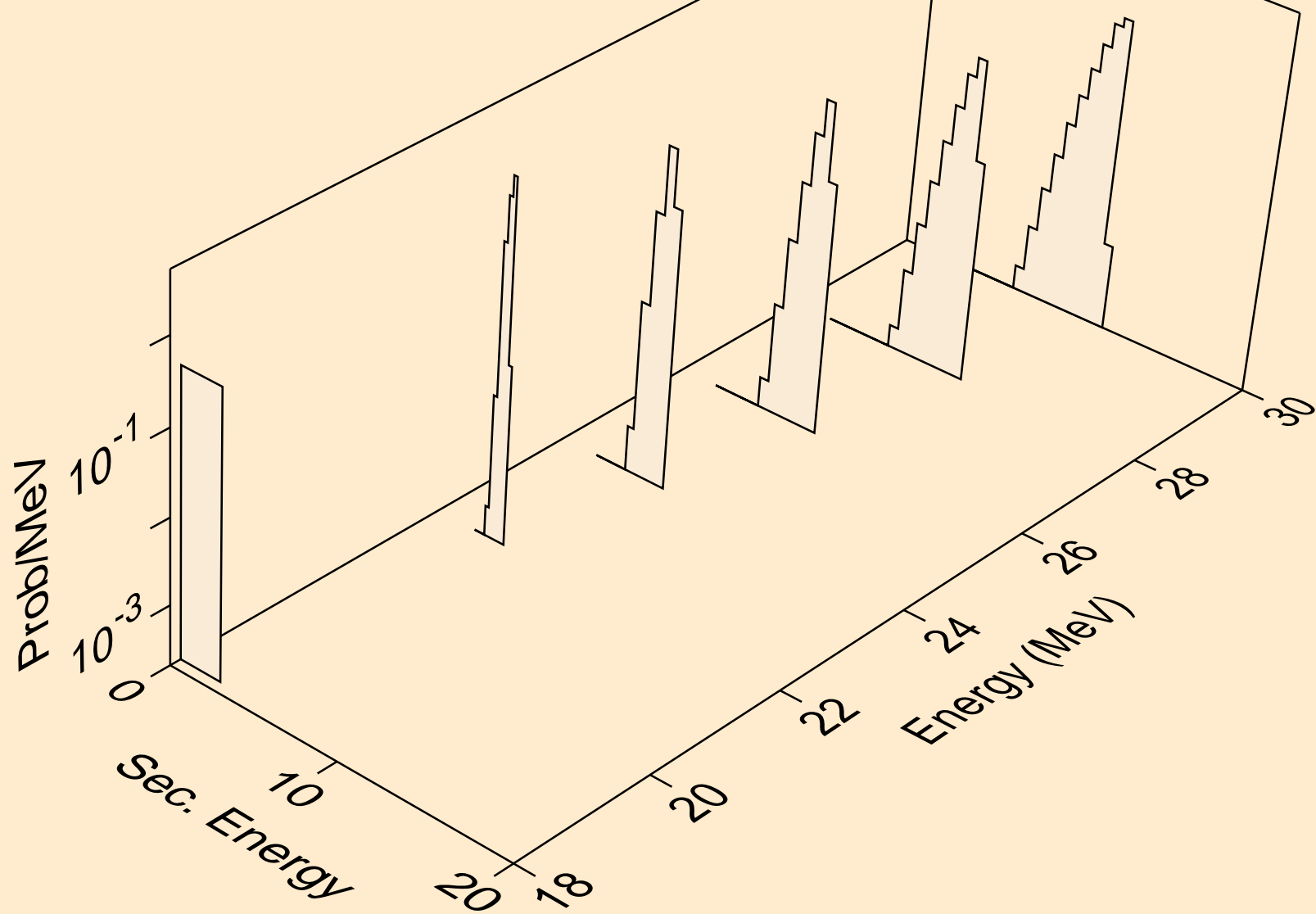

PD101 PROTON ACER TENDL-2024 LIBRARY; T=0.K  
he3s from (p,he3)

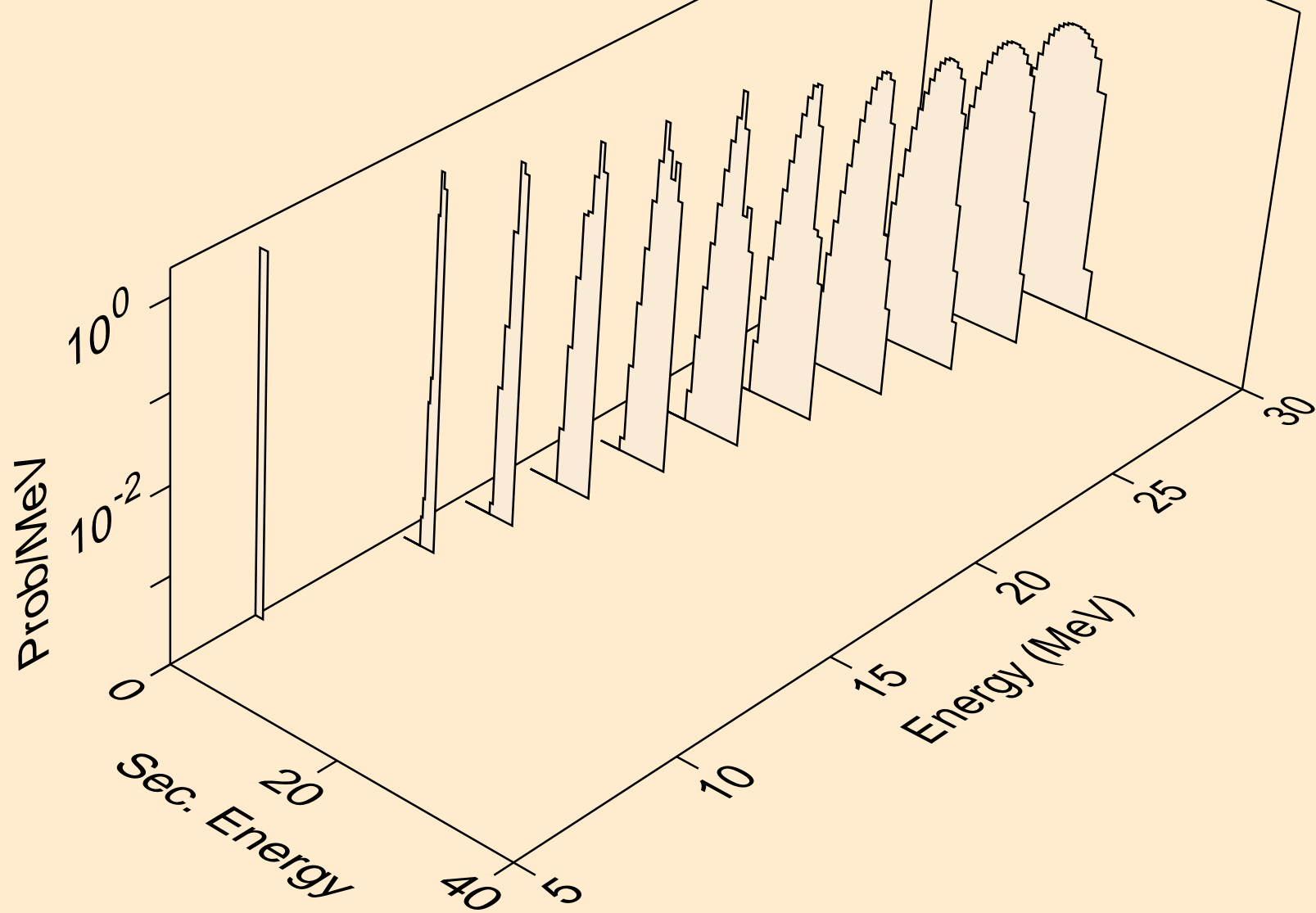

PD101 PROTON ACER TENDL-2024 LIBRARY; T=0.K  
alphas from (p,x)

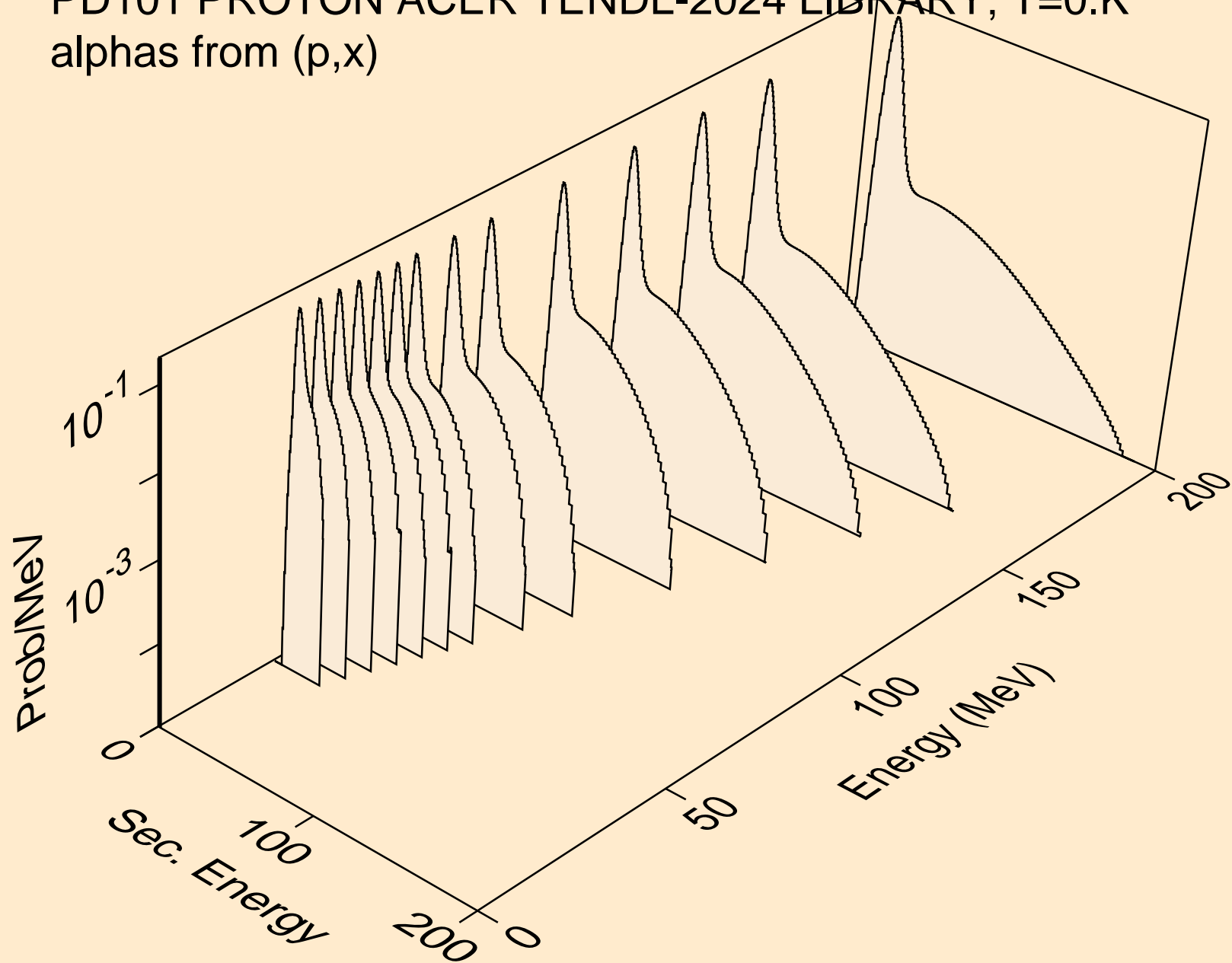

PD101 PROTON ACER TENDL-2024 LIBRARY; T=0.K  
alphas from (p,n\*)a

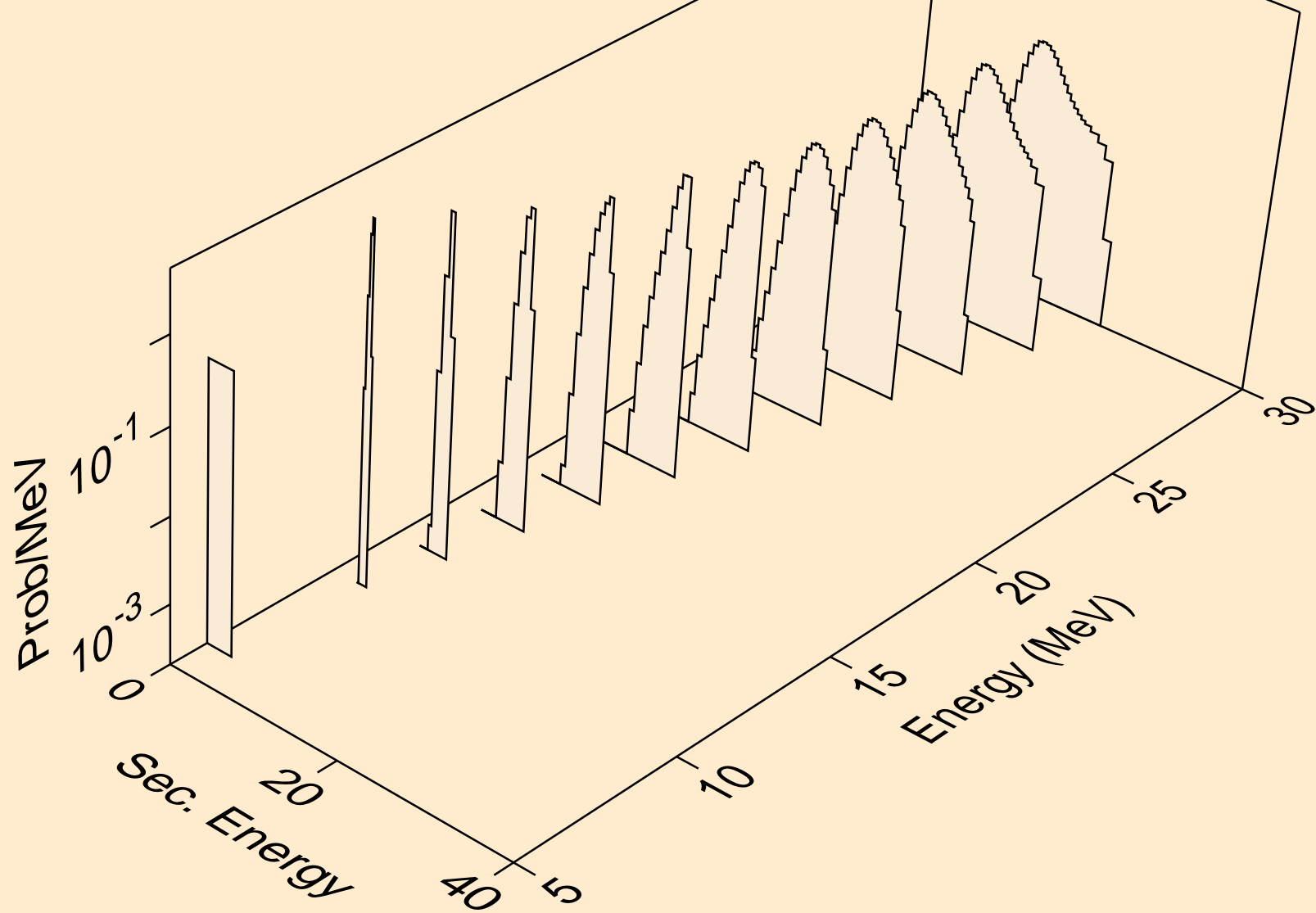

PD101 PROTON ACER TENDL-2024 LIBRARY; T=0.K  
alphas from (p,2n)a

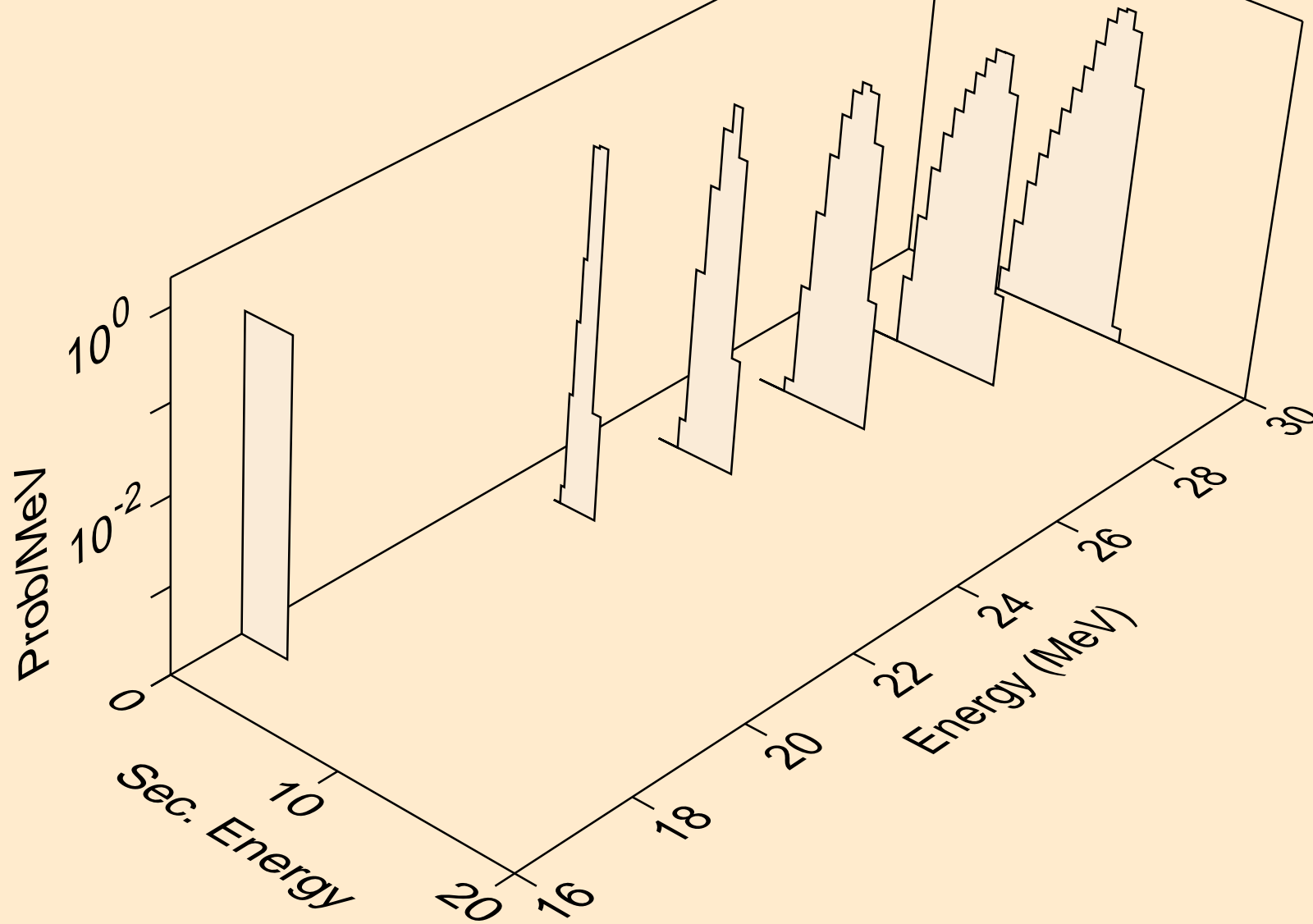

PD101 PROTON ACER TENDL-2024 LIBRARY; T=0.K  
alphas from (p,n\*)2a

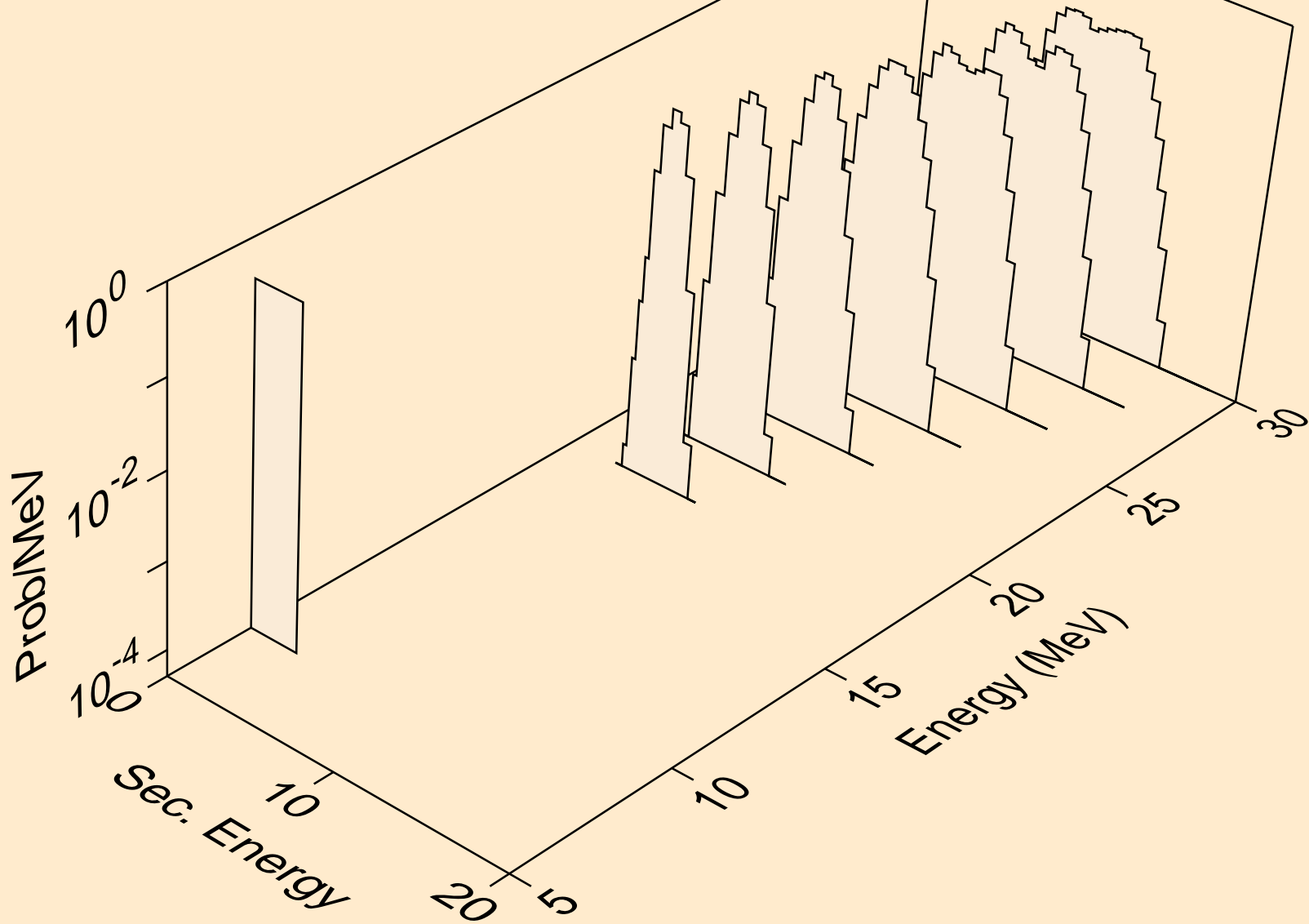

PD101 PROTON ACER TENDL-2024 LIBRARY; T=0.K  
alphas from (p,npa)

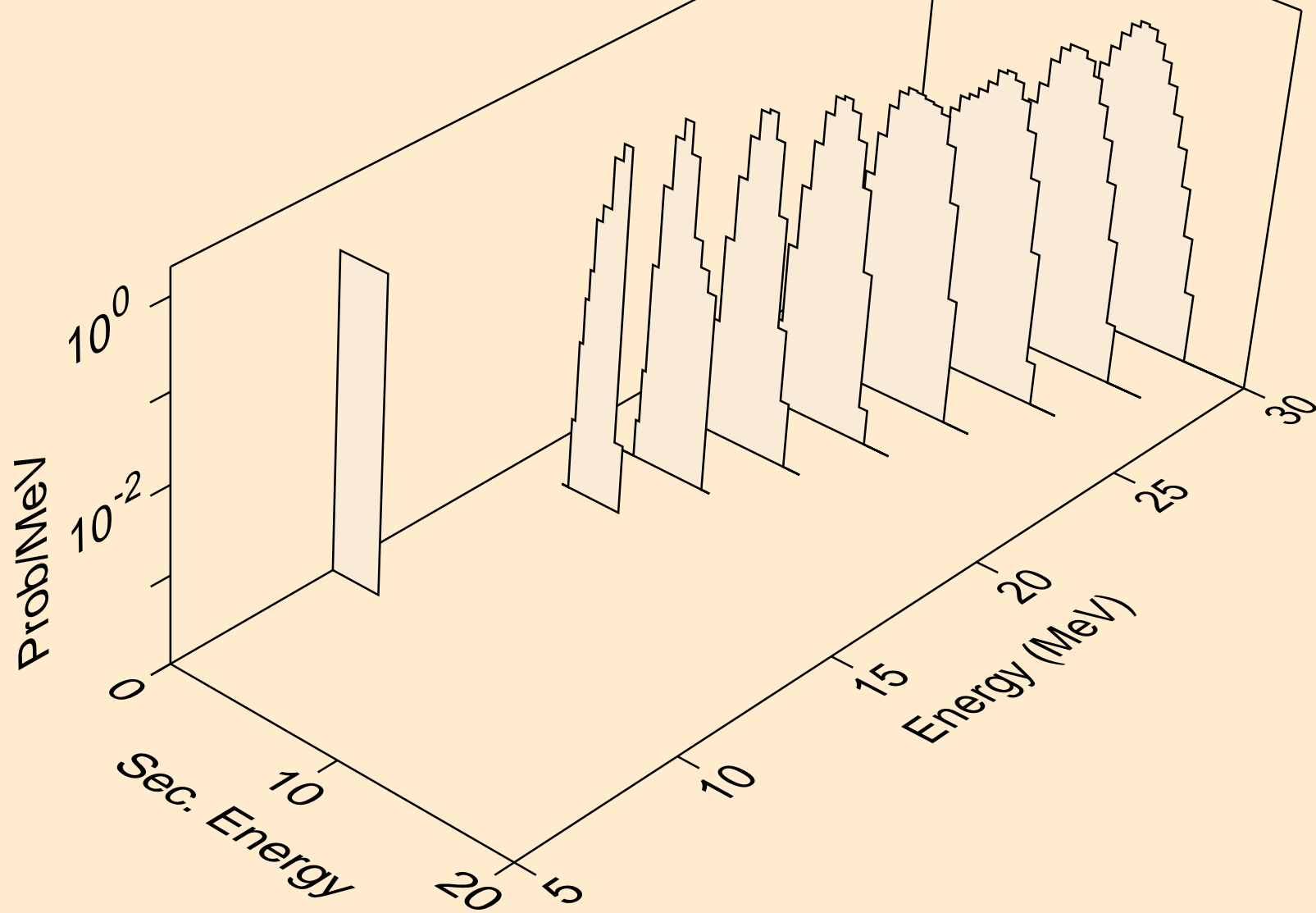

PD101 PROTON ACER TENDL-2024 LIBRARY; T=0.K  
alphas from (p,a)

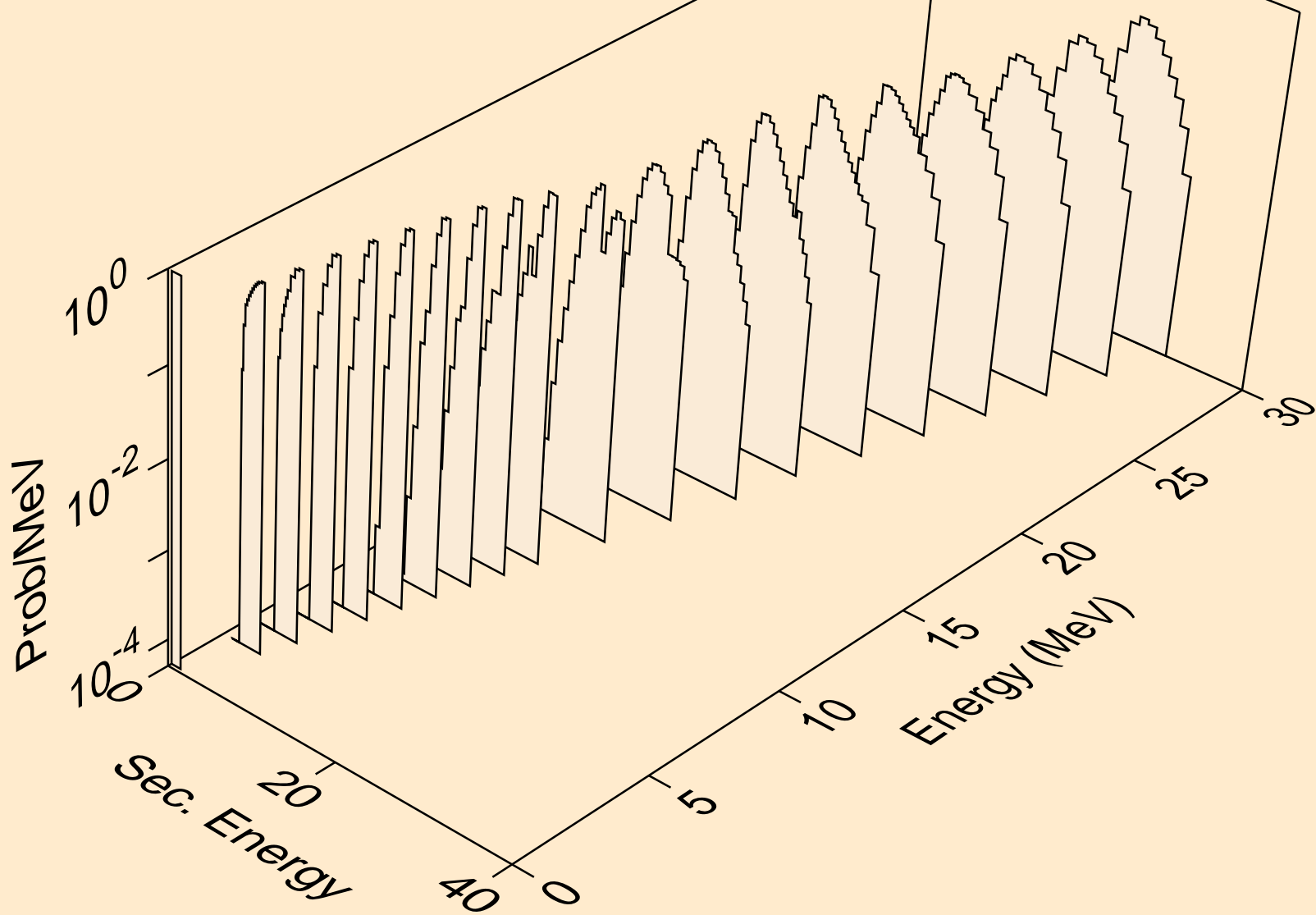

PD101 PROTON ACER TENDL-2024 LIBRARY; T=0.K  
alphas from (p,2a)

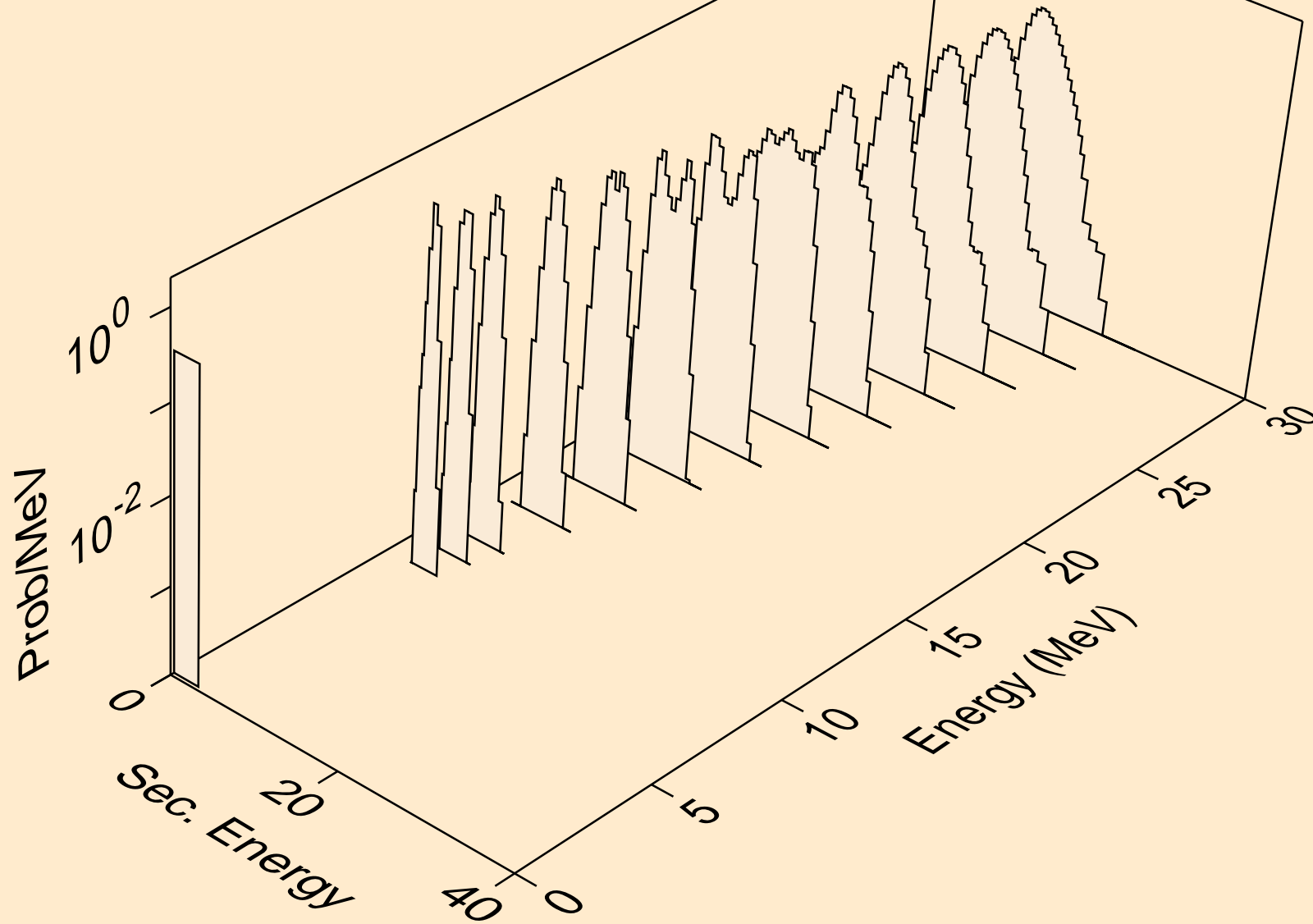

PD101 PROTON ACER TENDL-2024 LIBRARY; T=0.K  
alphas from (p,pa)

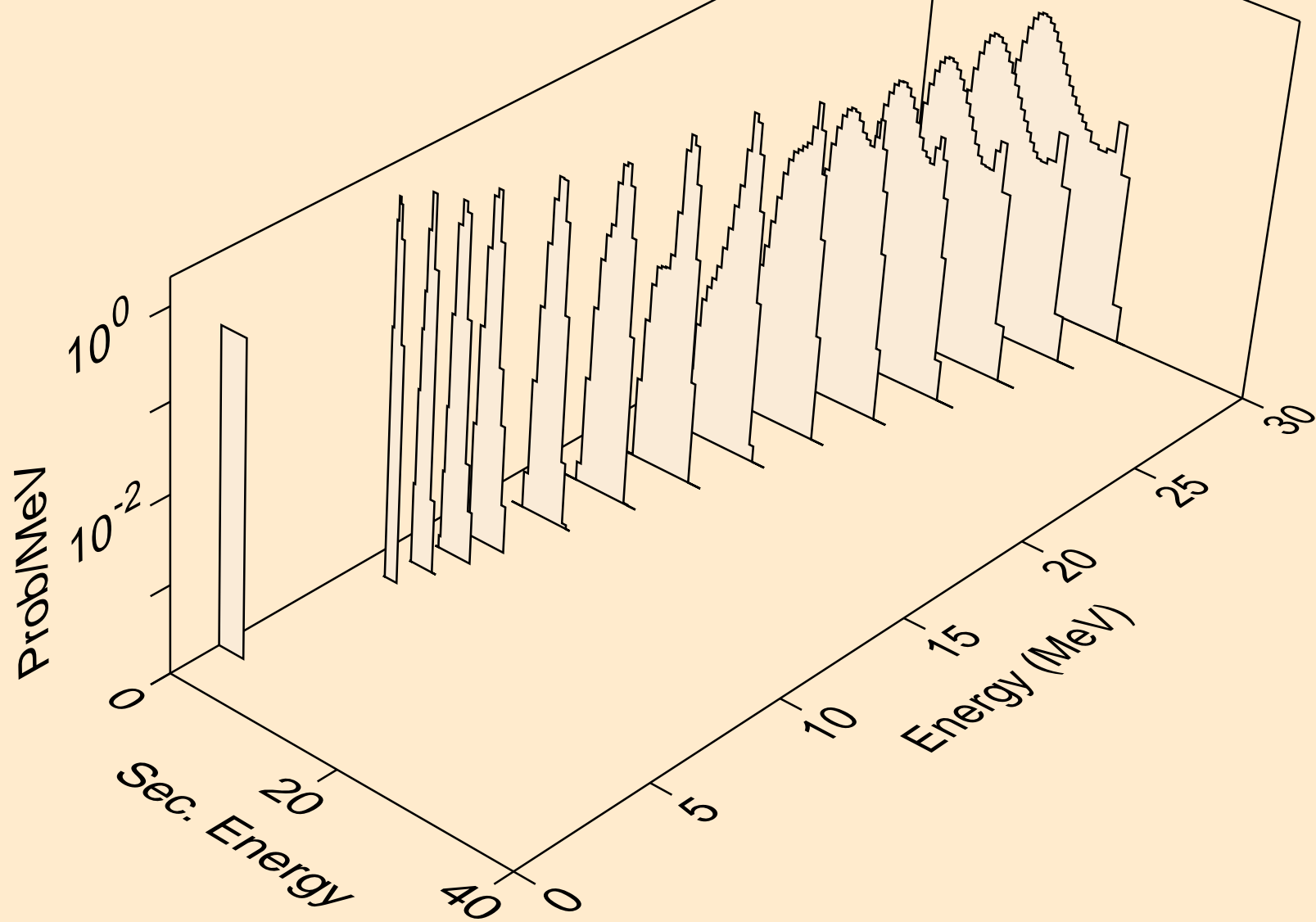

PD101 PROTON ACER TENDL-2024 LIBRARY; T=0.K  
alphas from (p,da)

