

# YB184 PROTON ACER TENDL-2024 LIBRARY; T=0.K

## Principal cross sections

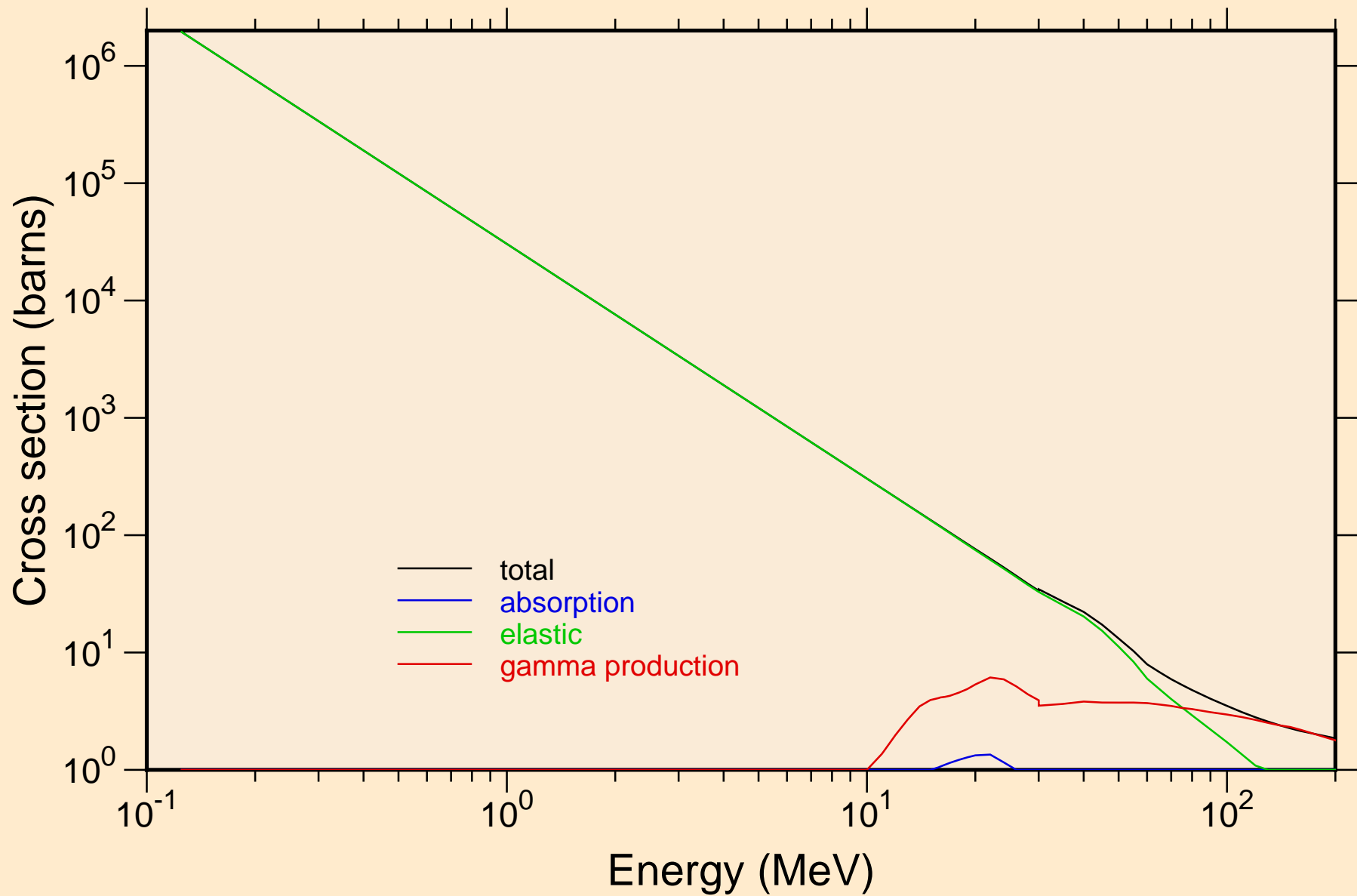

# YB184 PROTON ACER TENDL-2024 LIBRARY; T=0.K

## Heating

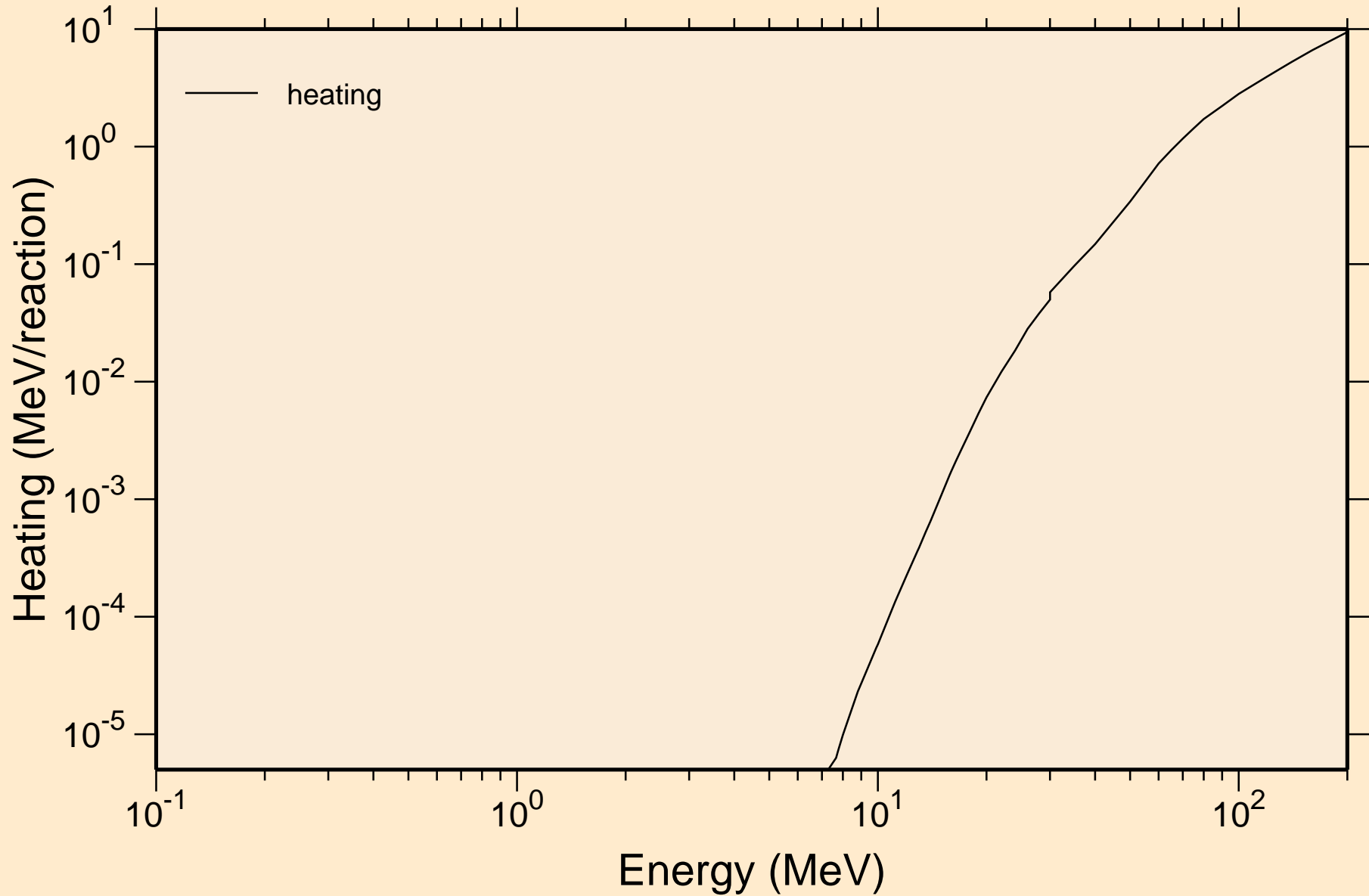

# YB184 PROTON ACER TENDL-2024 LIBRARY; T=0.K

## Principal cross sections

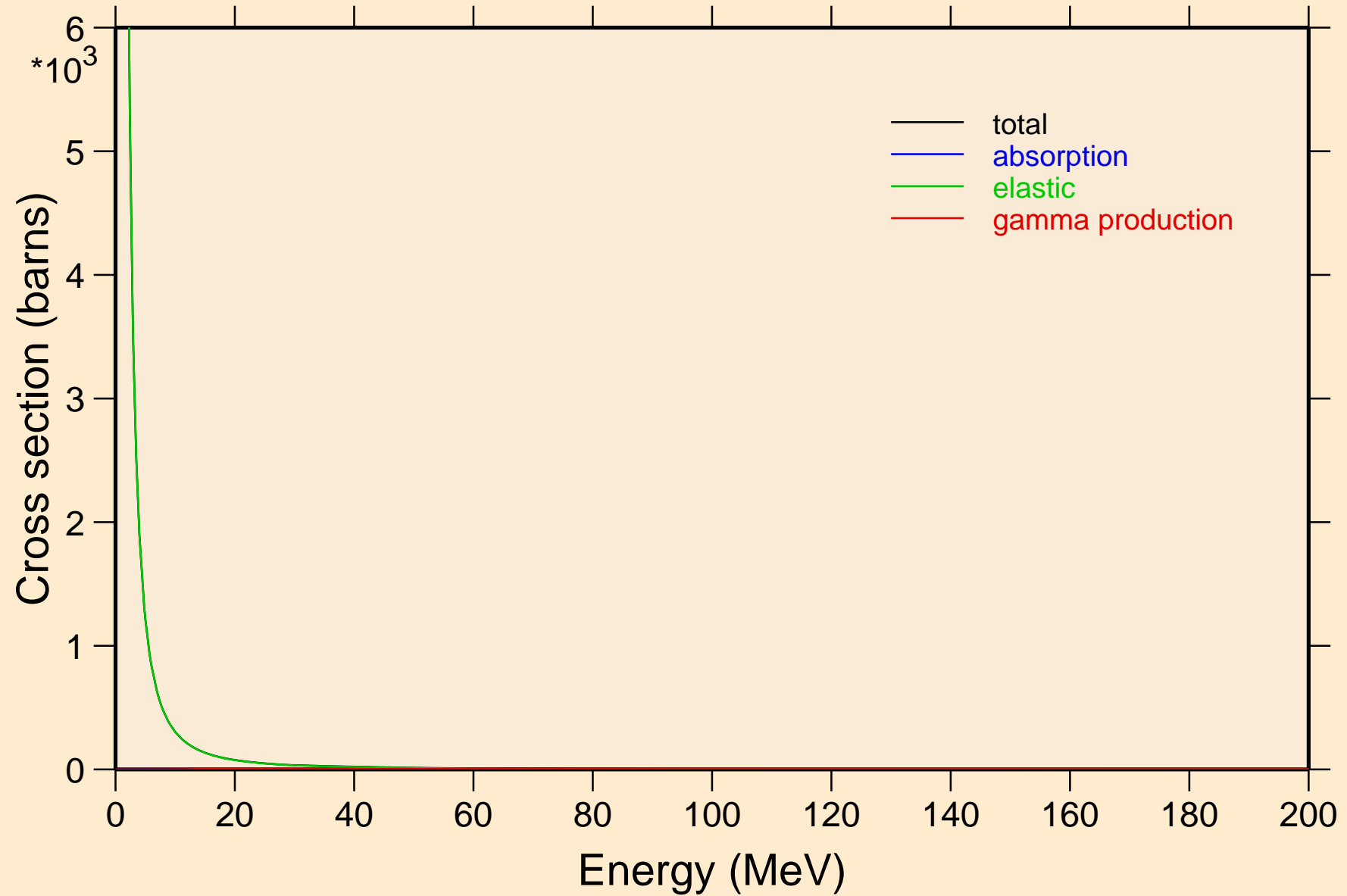

YB184 PROTON ACER TENDL-2024 LIBRARY; T=0.K

Heating

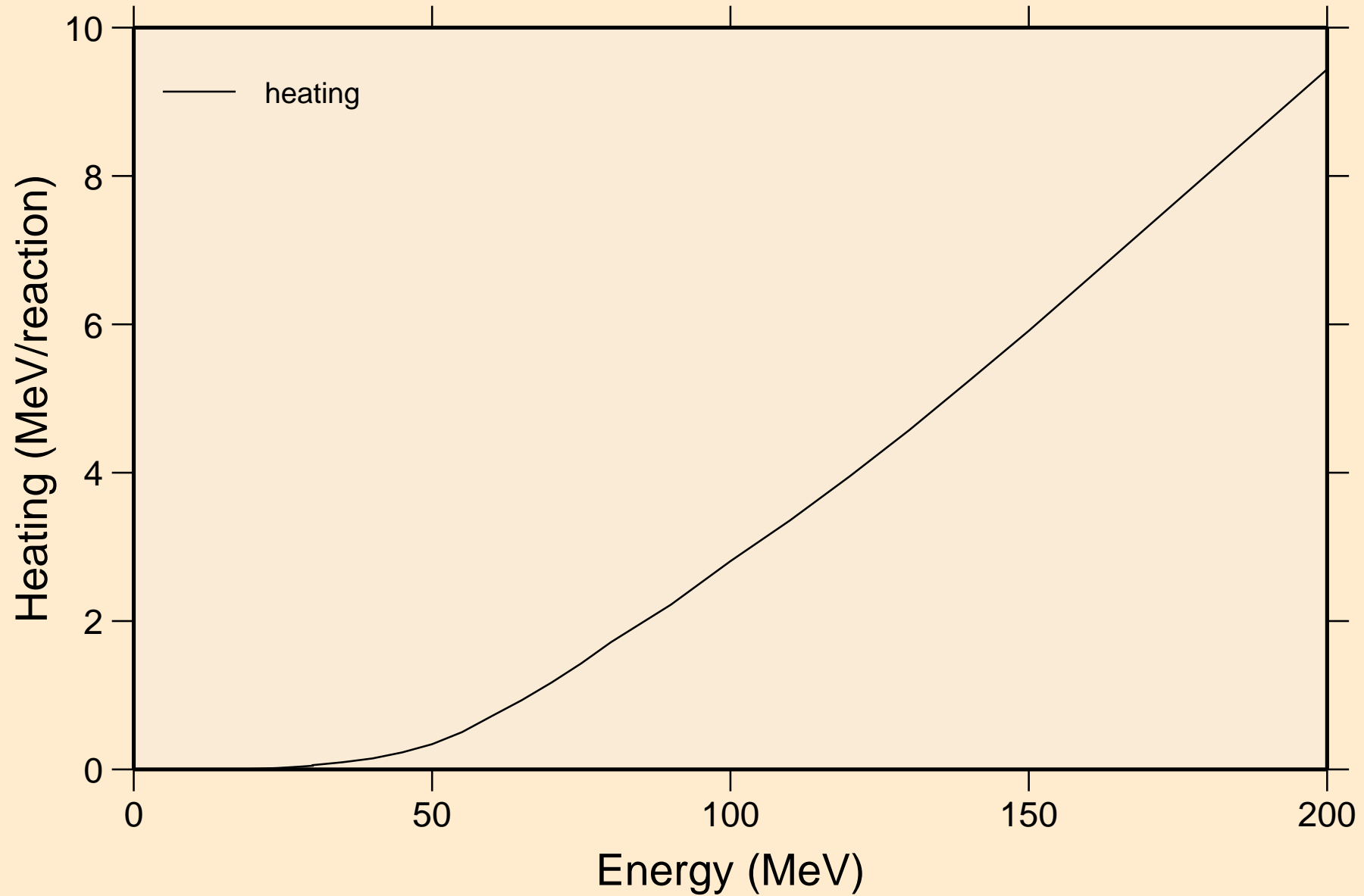

# YB184 PROTON ACER TENDL-2024 LIBRARY; T=0.K

## Threshold reactions

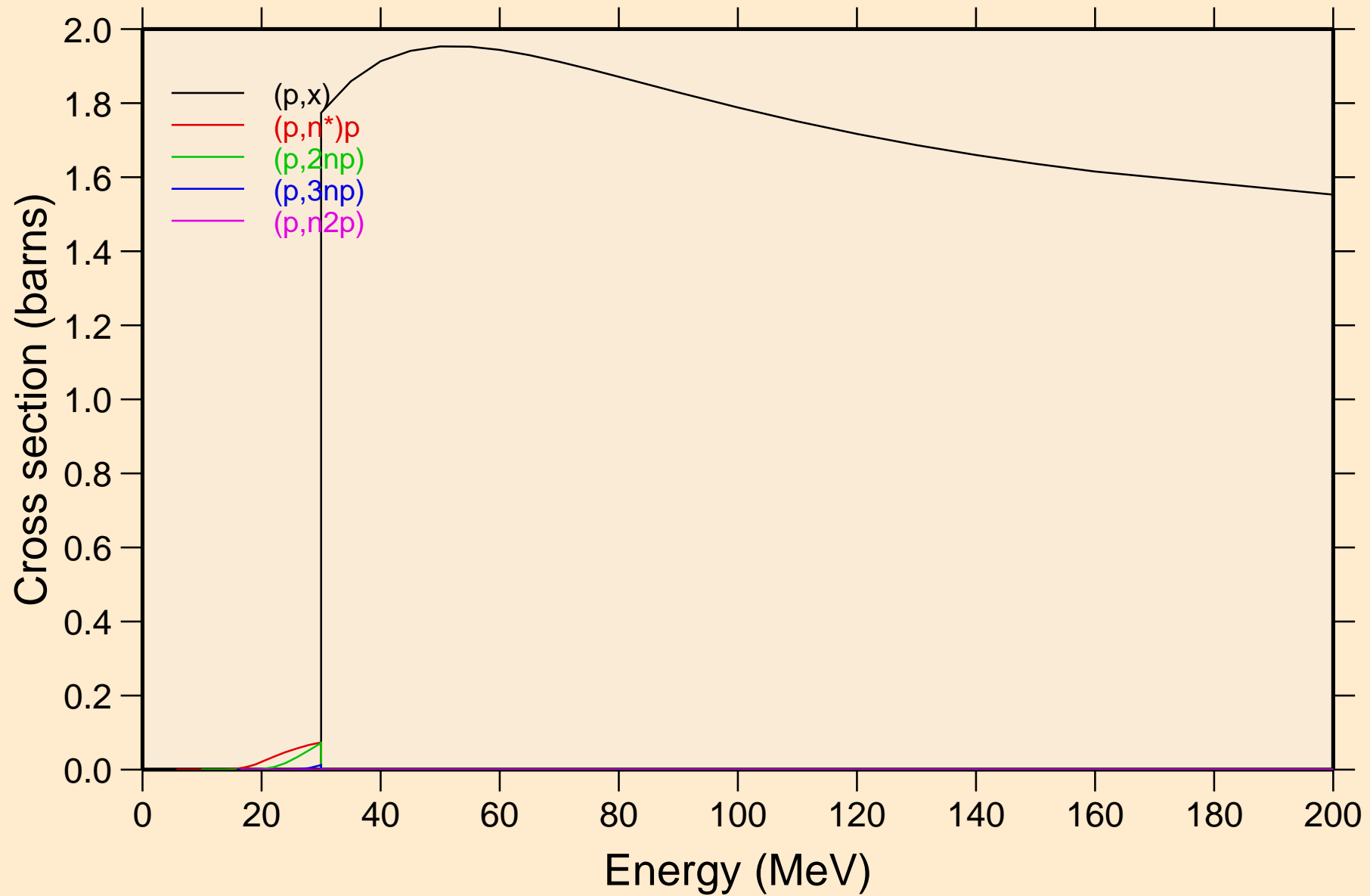

# YB184 PROTON ACER TENDL-2024 LIBRARY; T=0.K

## Threshold reactions

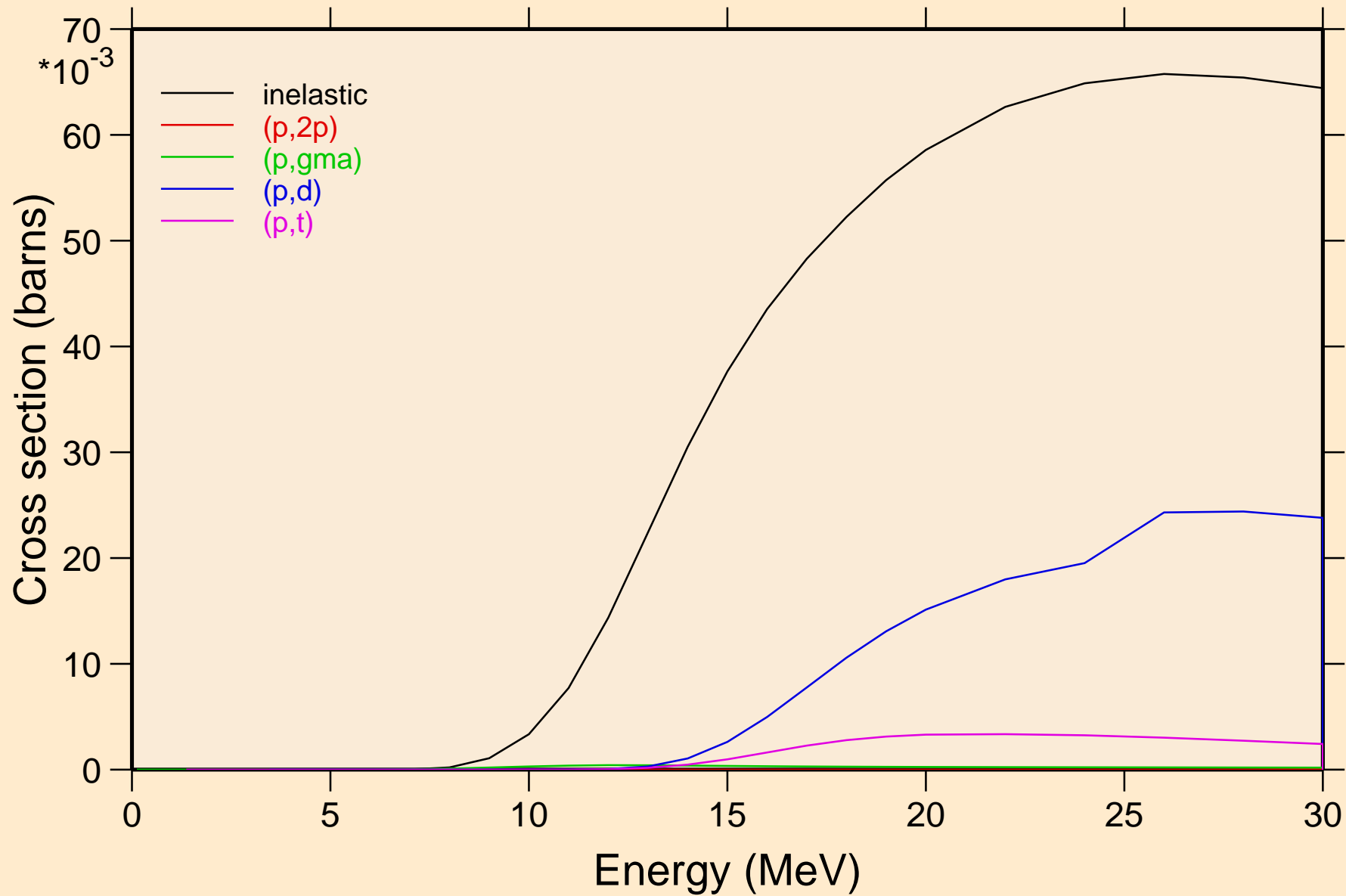

YB184 PROTON ACER TENDL-2024 LIBRARY; T=0.K  
Threshold reactions

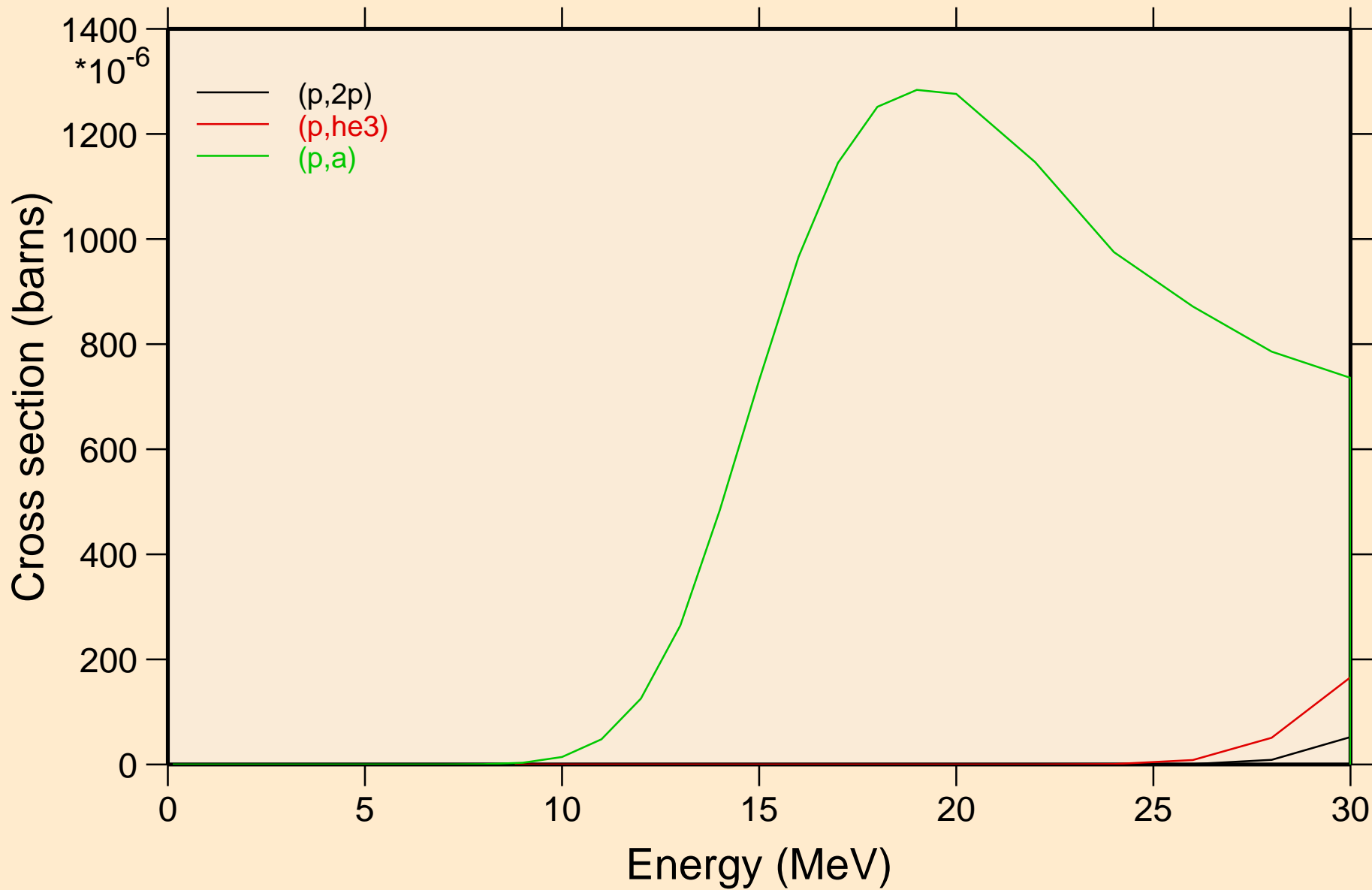

# YB184 PROTON ACER TENDL-2024 LIBRARY; T=0.K

## Threshold reactions

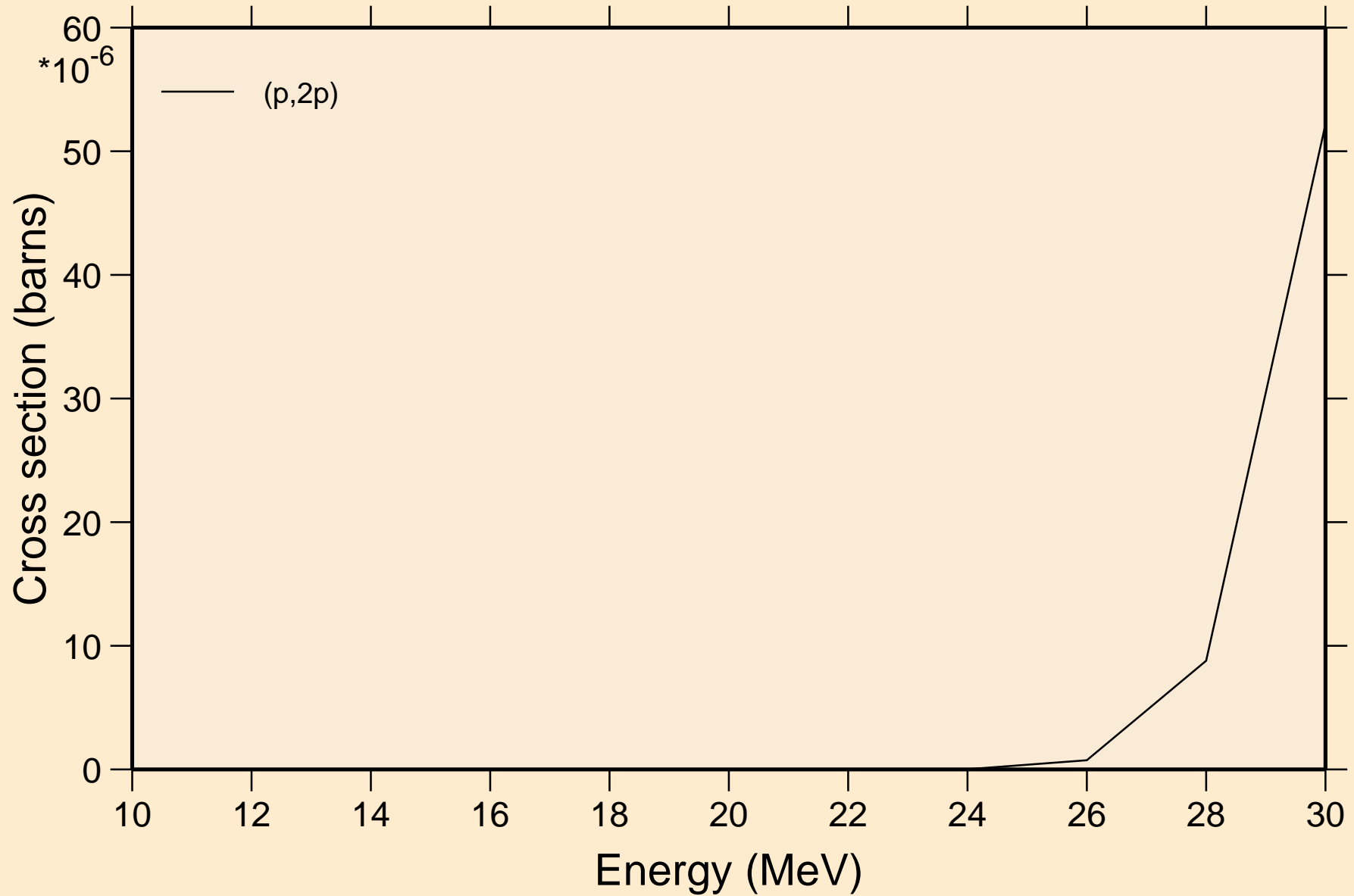

YB184 PROTON ACER TENDL-2024 LIBRARY; T=0.K  
angular distribution for elastic

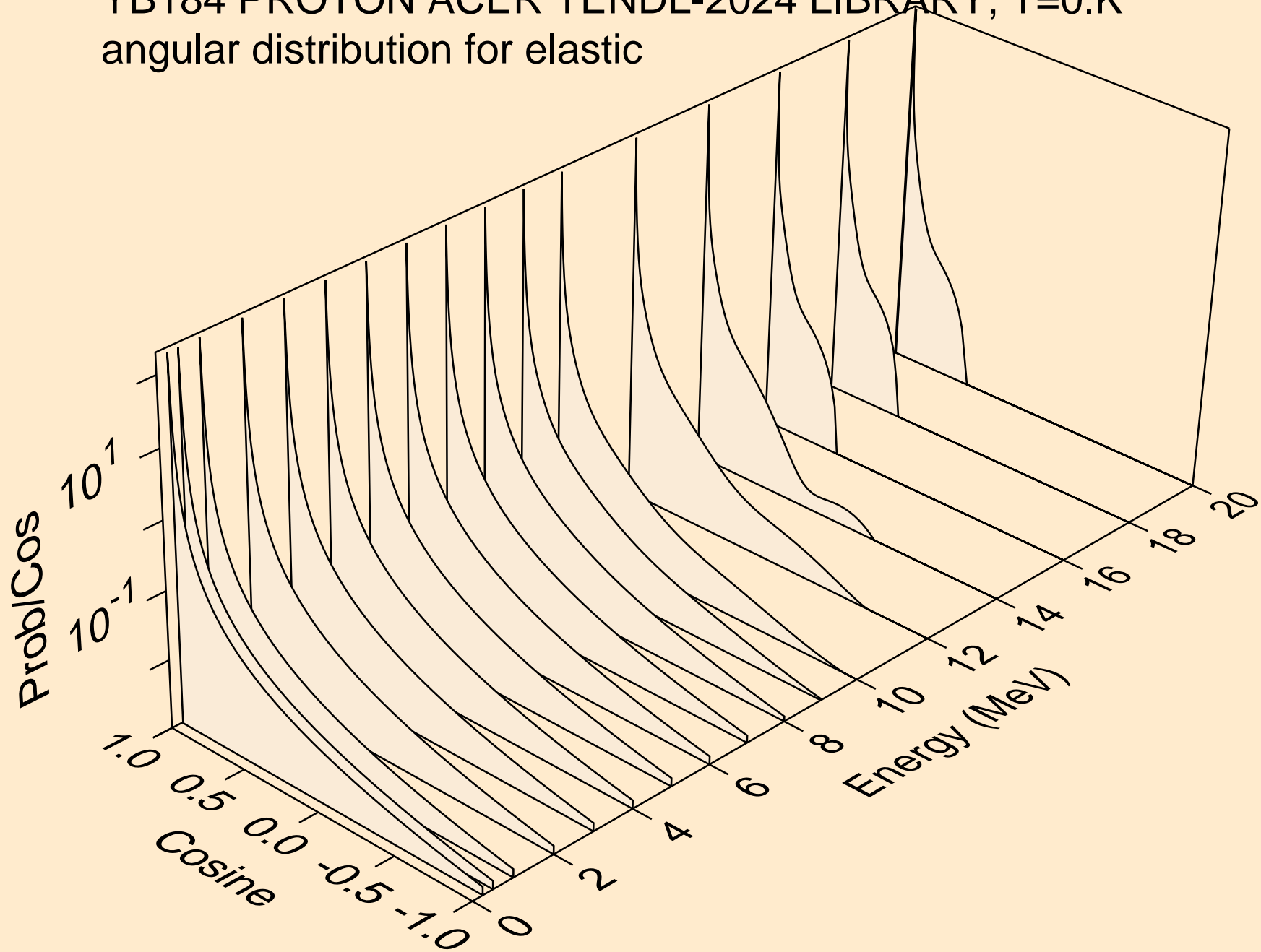

YB184 PROTON ACER TENDL-2024 LIBRARY; T=0.K  
angular distribution for elastic

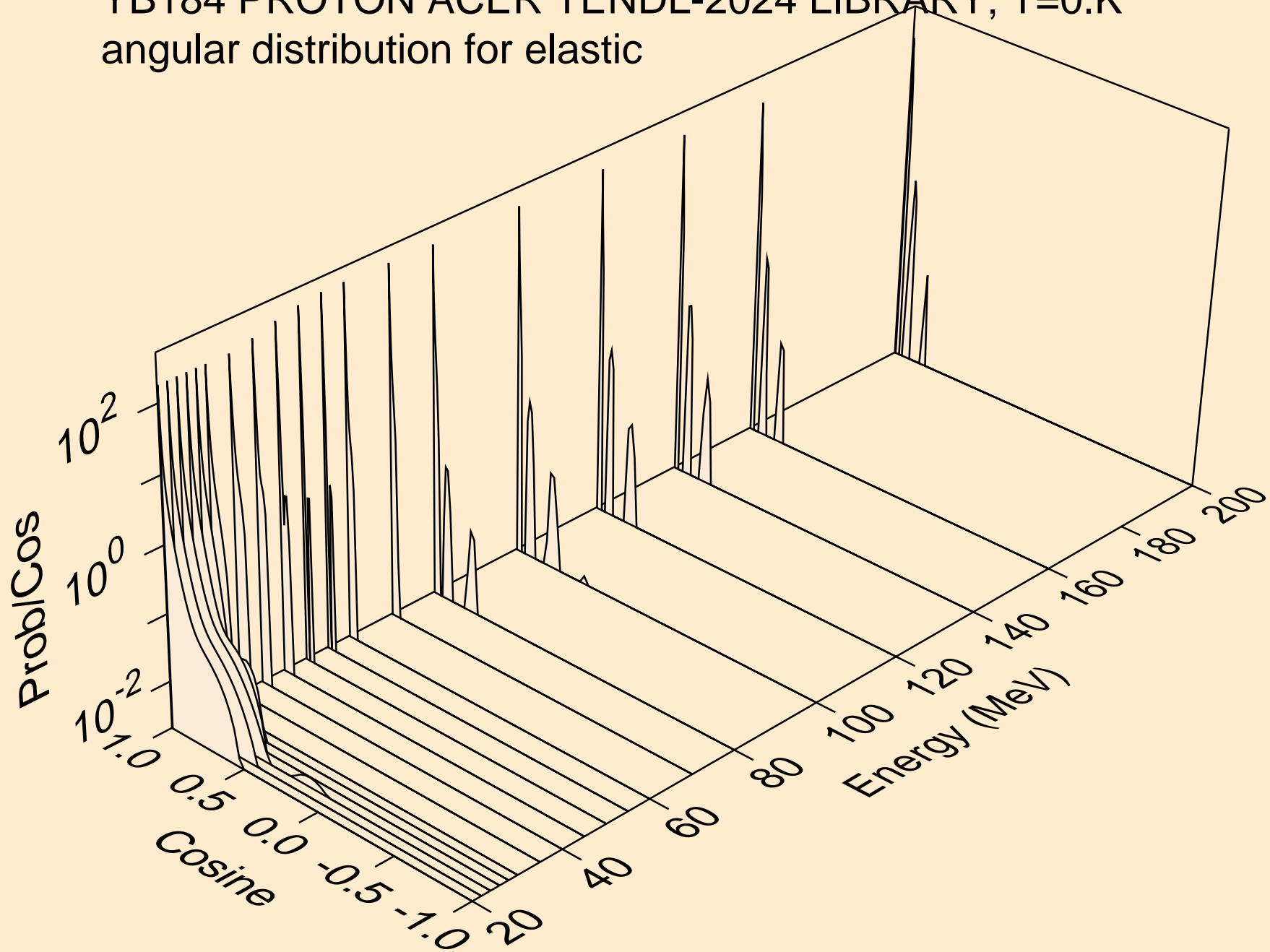

YB184 PROTON ACER TENDL-2024 LIBRARY; T=0.K  
Proton emission for (p,x)

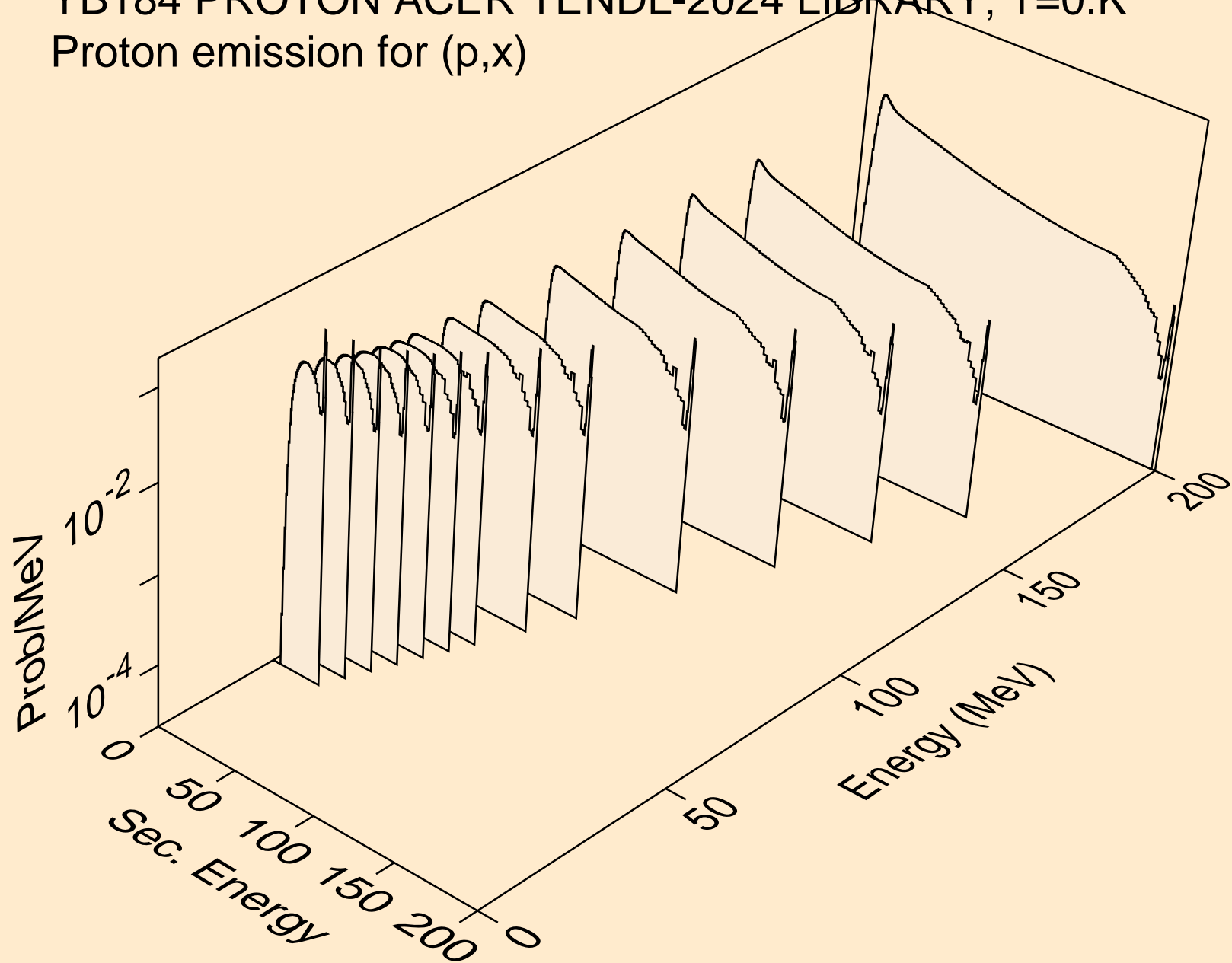

YB184 PROTON ACER TENDL-2024 LIBRARY; T=0.K  
Proton emission for (p,n\*)p

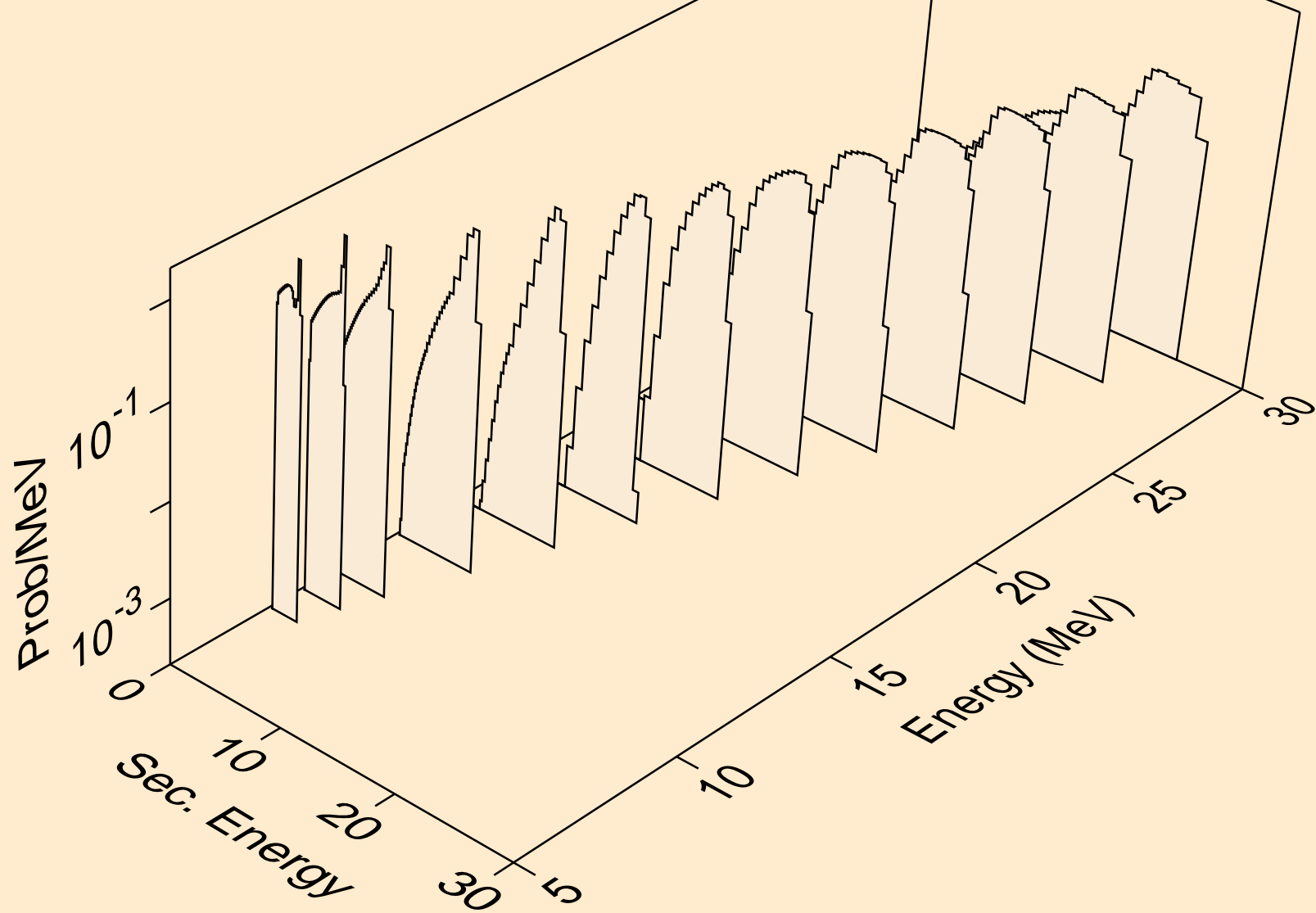

YB184 PROTON ACER TENDL-2024 LIBRARY; T=0.K  
Proton emission for (p,2np)

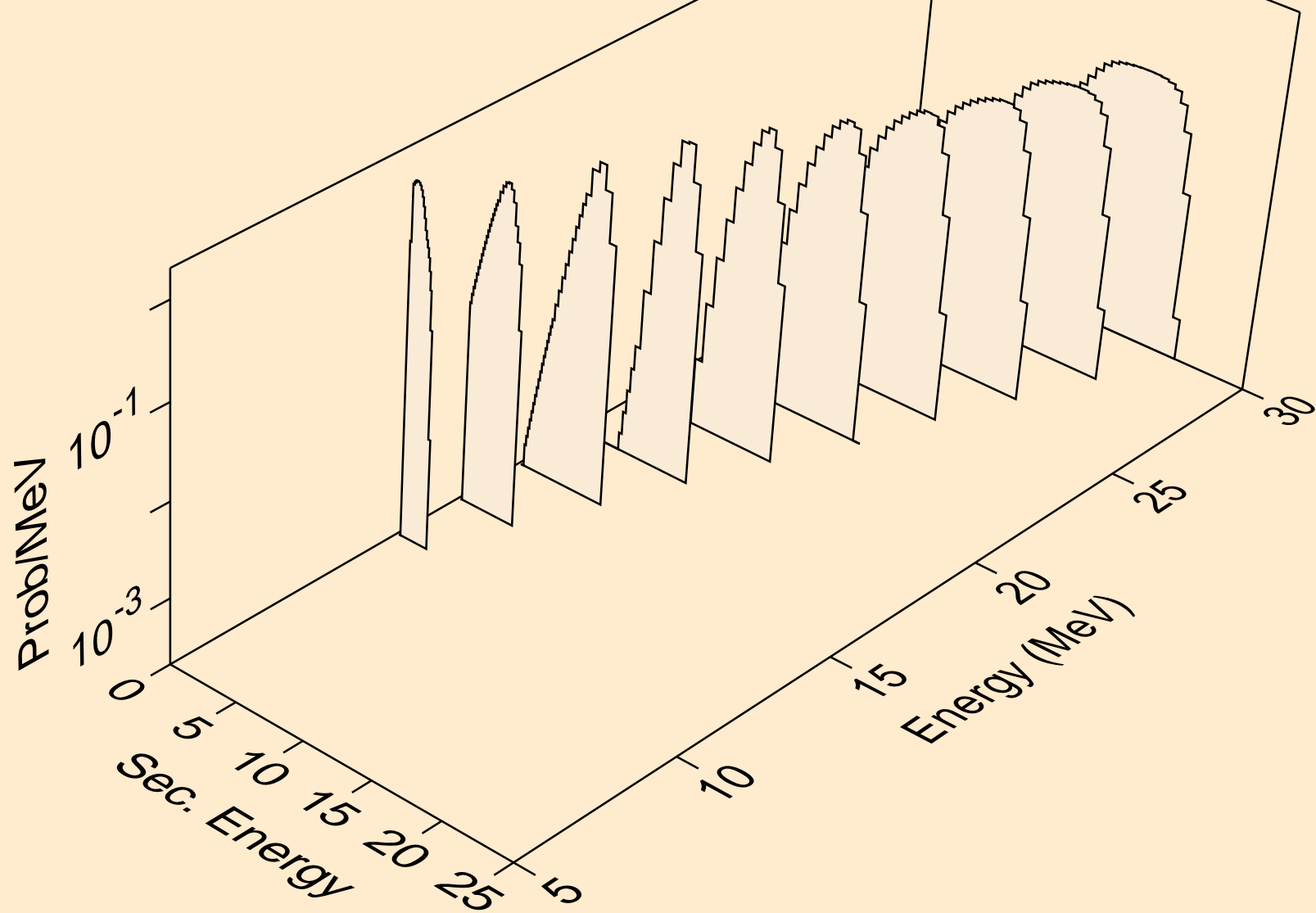

YB184 PROTON ACER TENDL-2024 LIBRARY; T=0.K  
Proton emission for (p,3np)

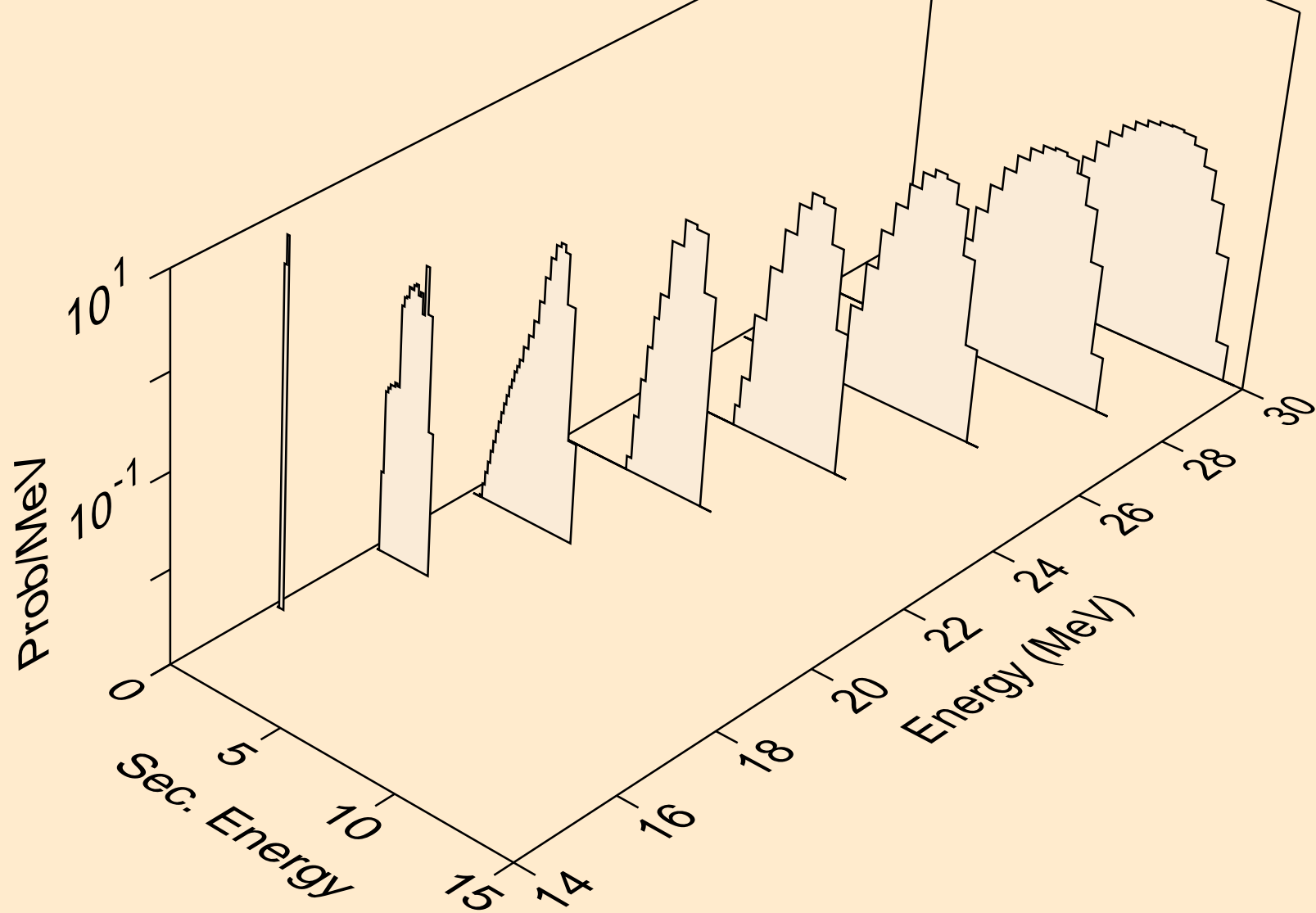

YB184 PROTON ACER TENDL-2024 LIBRARY; T=0.K  
Proton emission for (p,n2p)

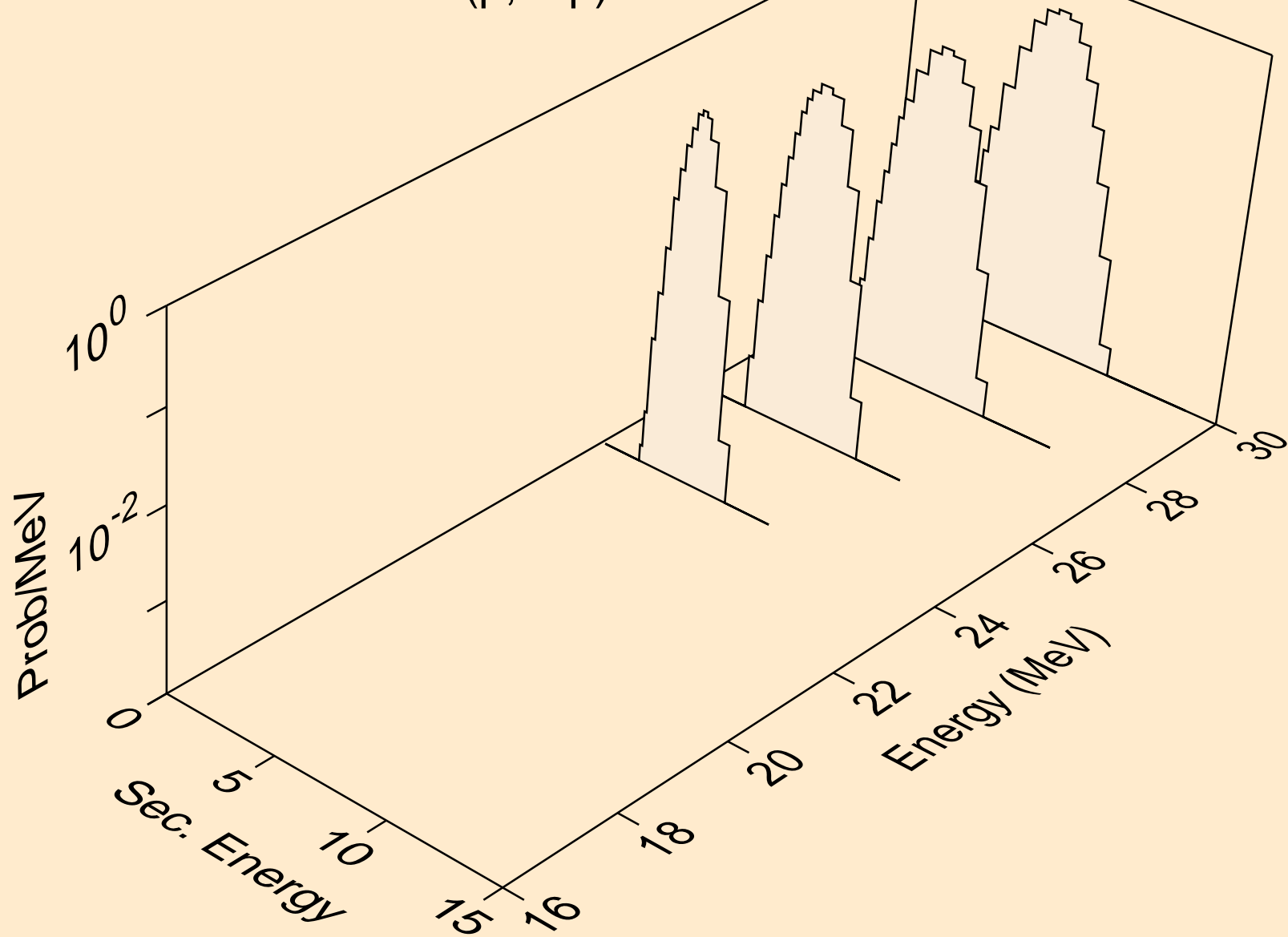

YB184 PROTON ACER TENDL-2024 LIBRARY; T=0.K  
Proton emission for inelastic

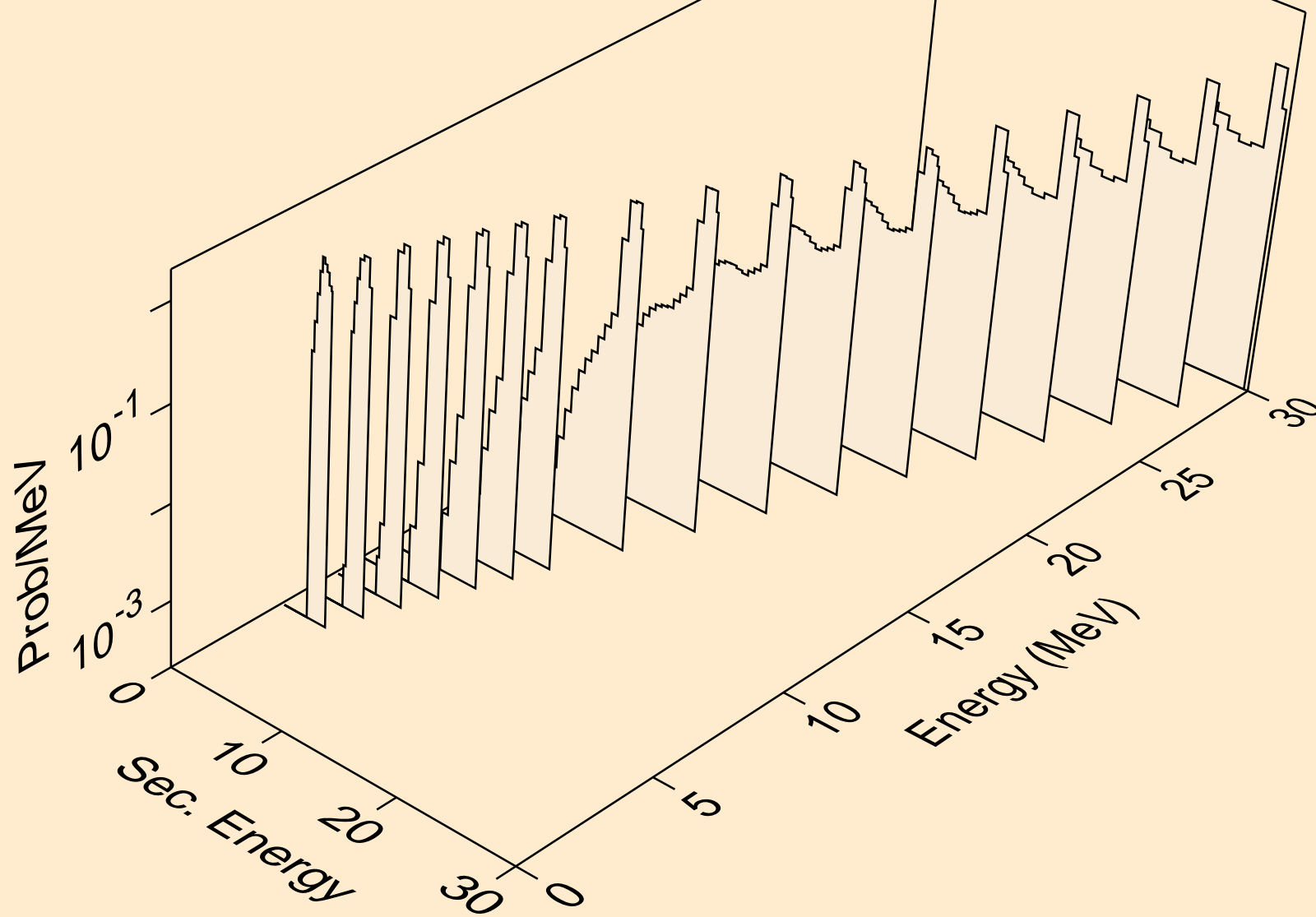

YB184 PROTON ACER TENDL-2024 LIBRARY; T=0.K  
Proton emission for (p,2p)

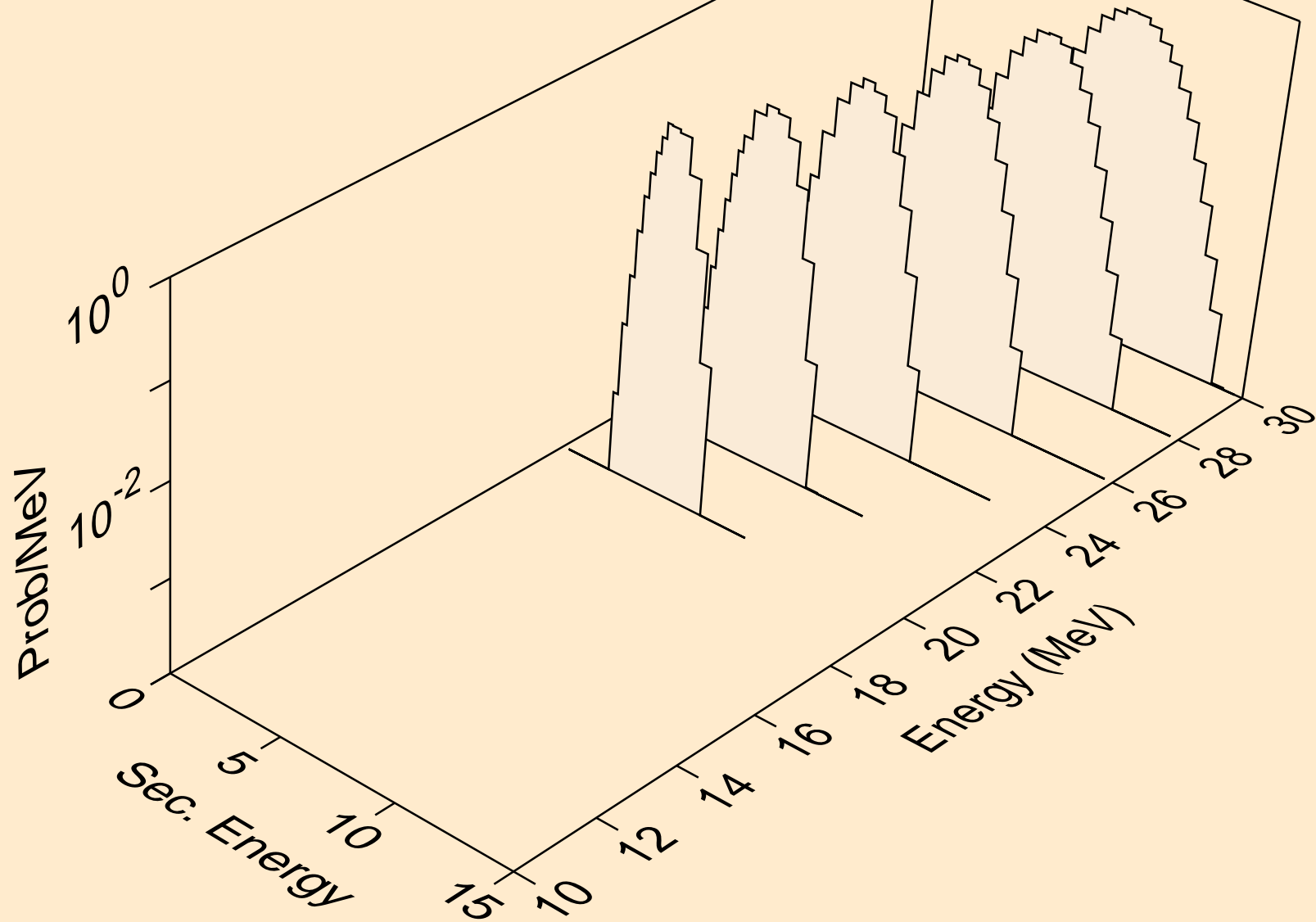

YB184 PROTON ACER TENDL-2024 LIBRARY; T=0.K  
Photon emission for (z,n)

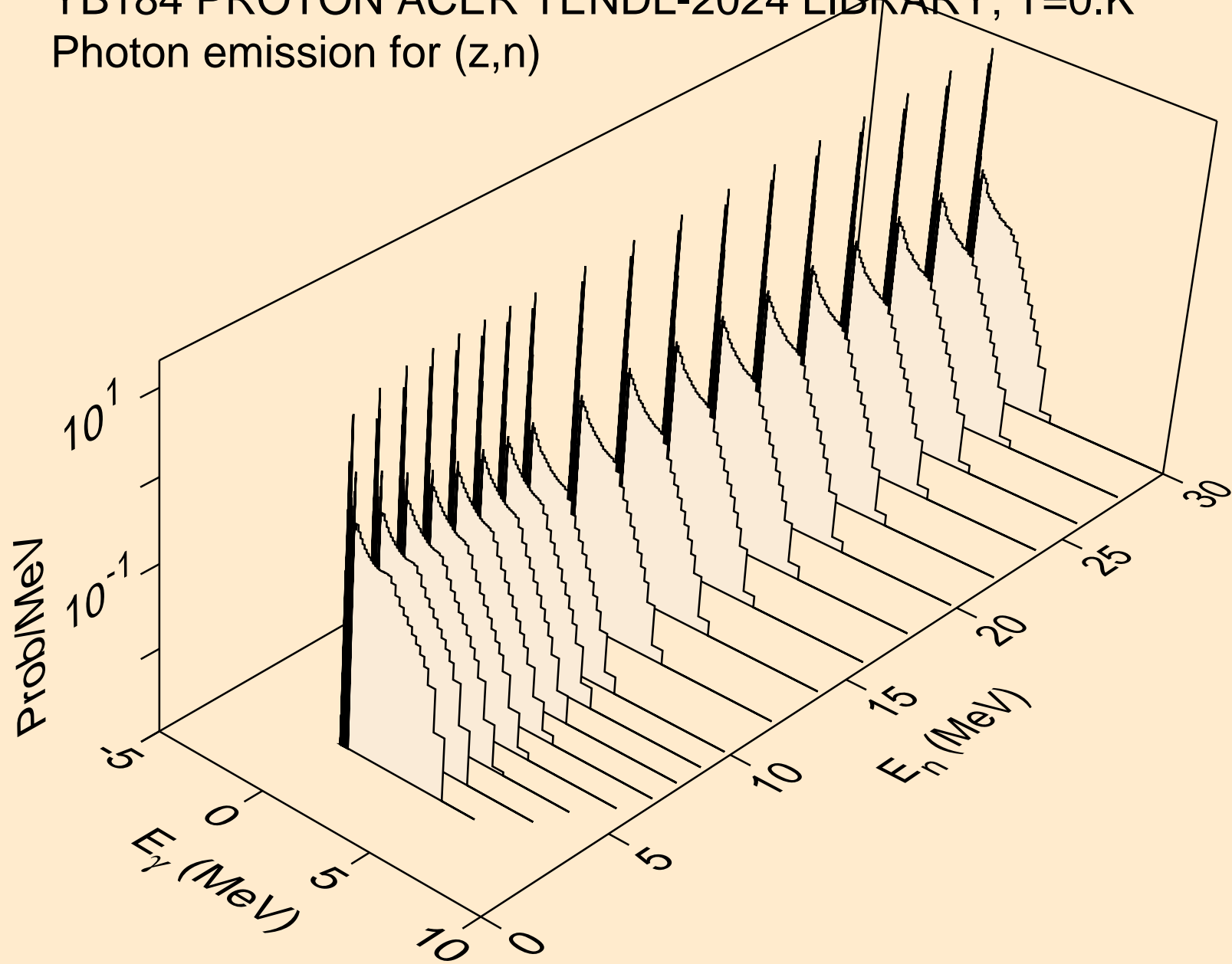

YB184 PROTON ACER TENDL-2024 LIBRARY; T=0.K  
Photon emission for (z,x)

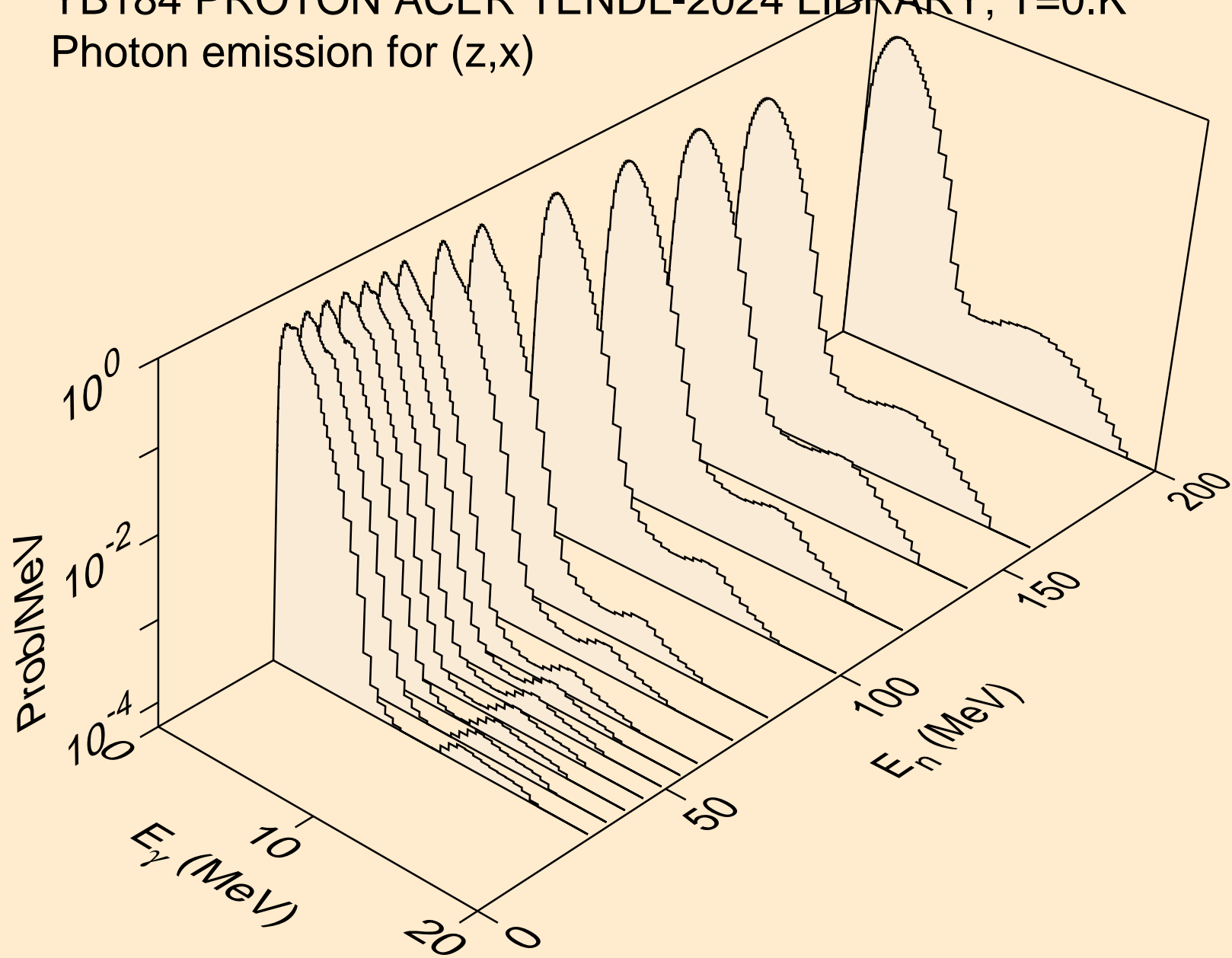

YB184 PROTON ACER TENDL-2024 LIBRARY; T=0.K  
Photon emission for (n,2nd)

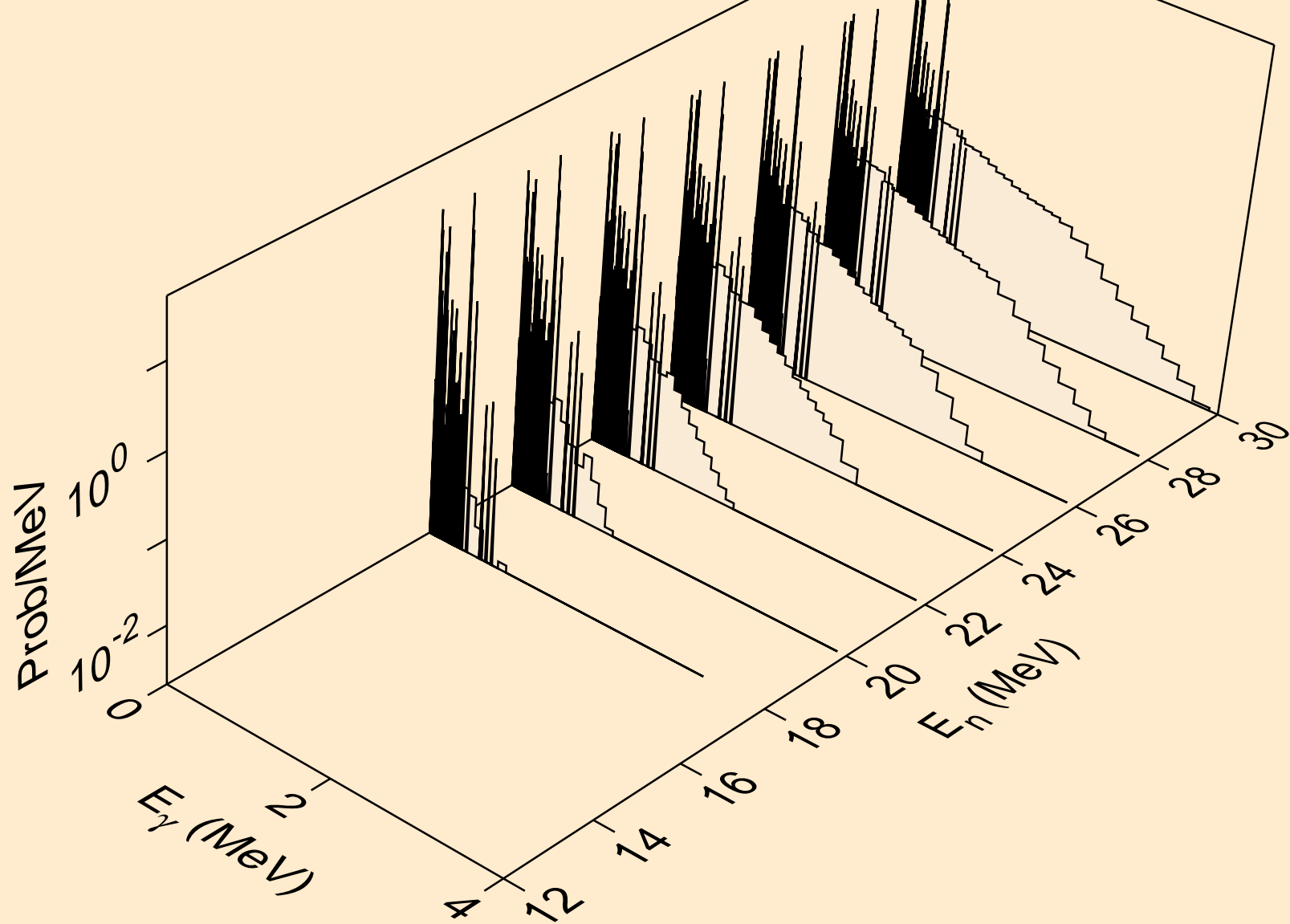

YB184 PROTON ACER TENDL-2024 LIBRARY; T=0.K  
Photon emission for (n,2n)

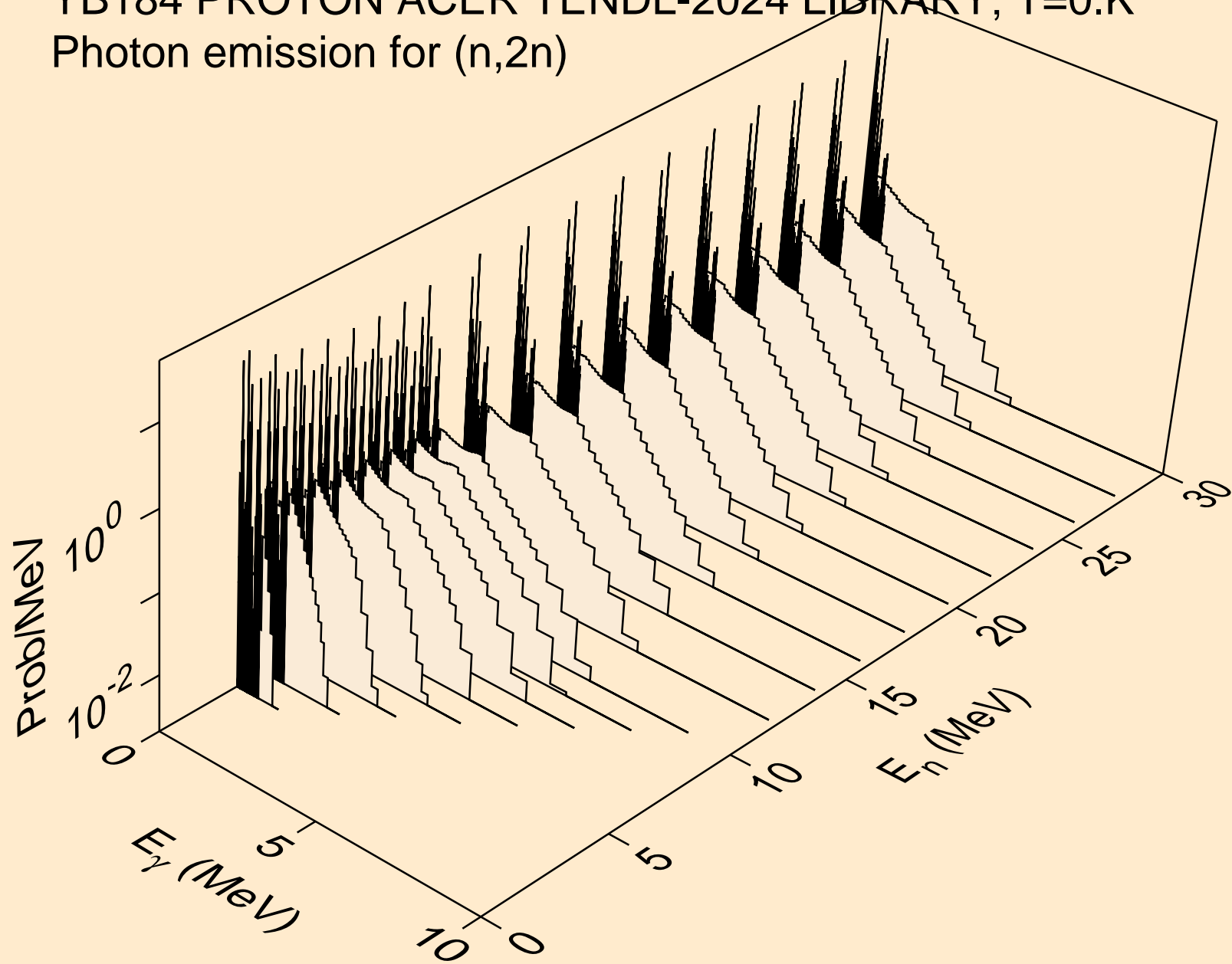

YB184 PROTON ACER TENDL-2024 LIBRARY; T=0.K  
Photon emission for (n,3n)

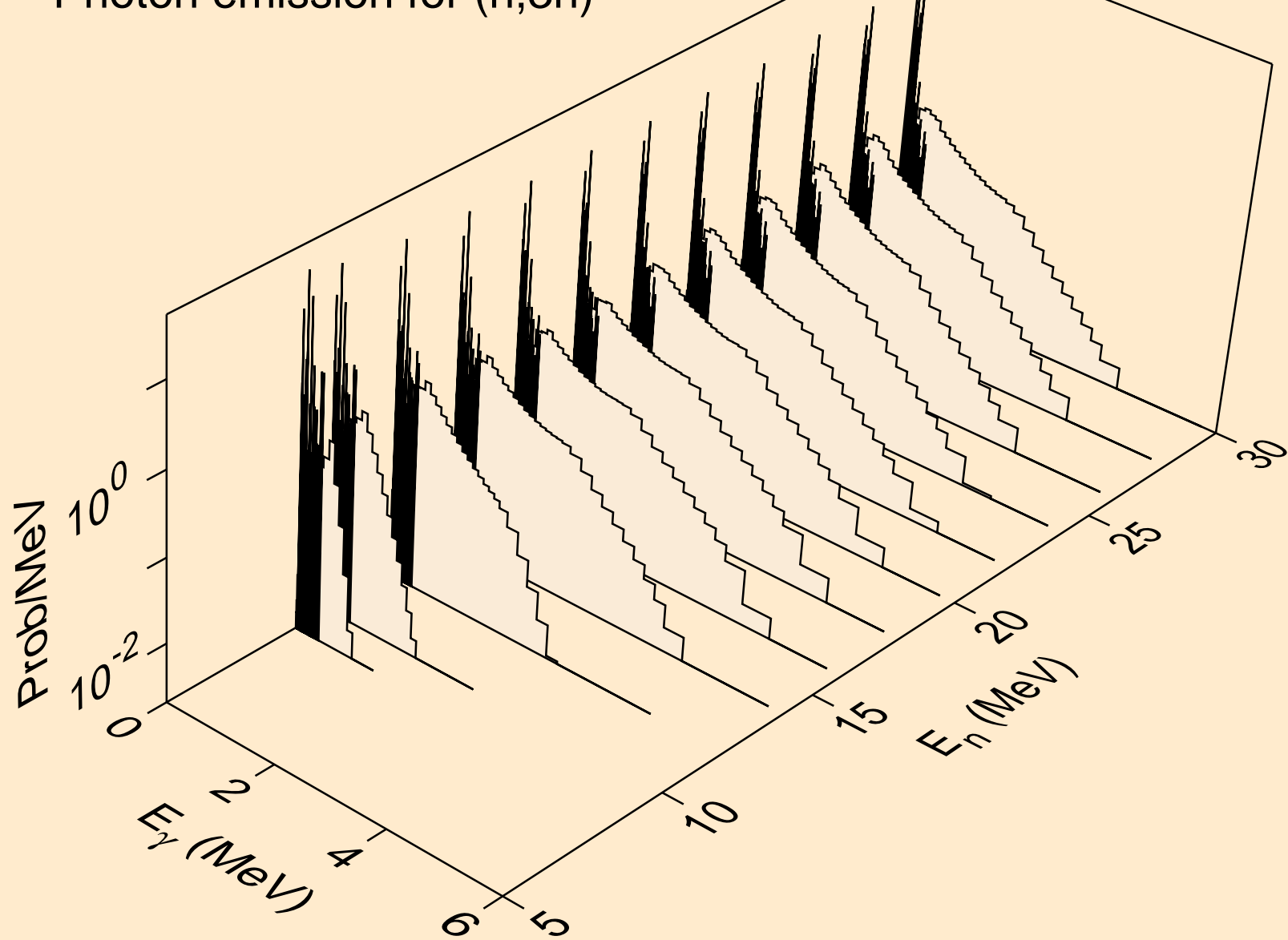

YB184 PROTON ACER TENDL-2024 LIBRARY; T=0.K  
Photon emission for (n,n\*)a

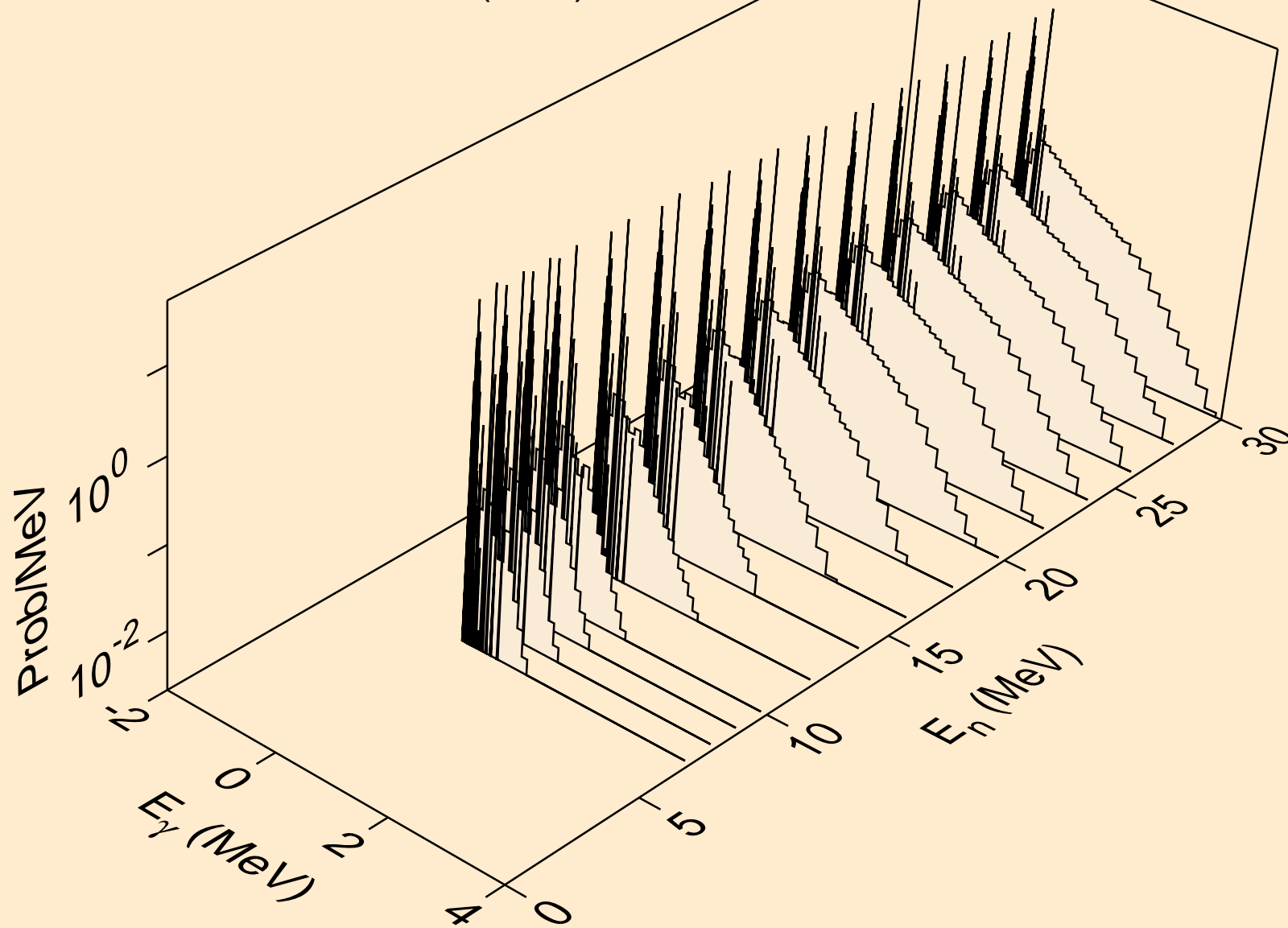

YB184 PROTON ACER TENDL-2024 LIBRARY; T=0.K  
Photon emission for (n,2n)a

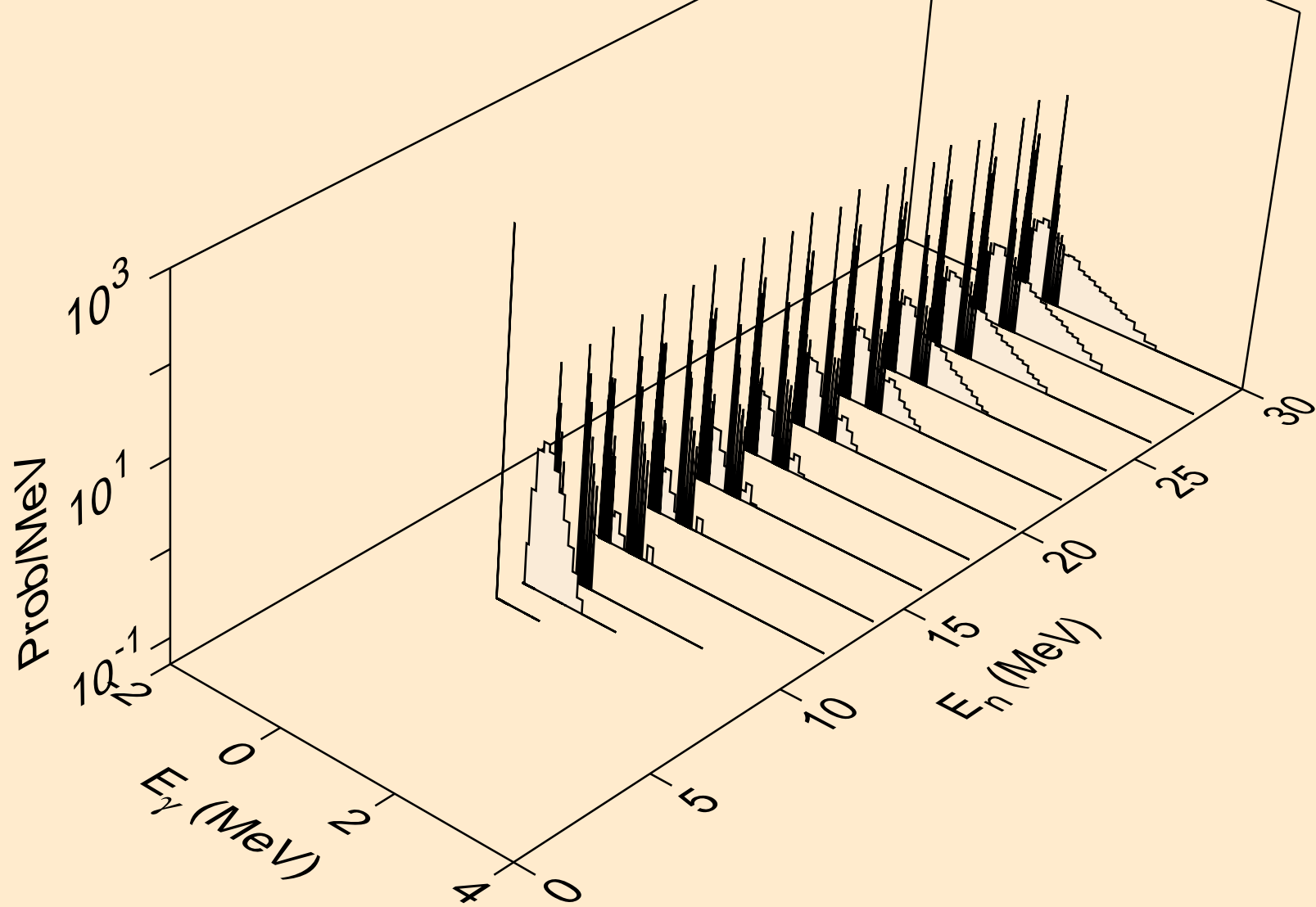

YB184 PROTON ACER TENDL-2024 LIBRARY; T=0.K  
Photon emission for (n,3n)a

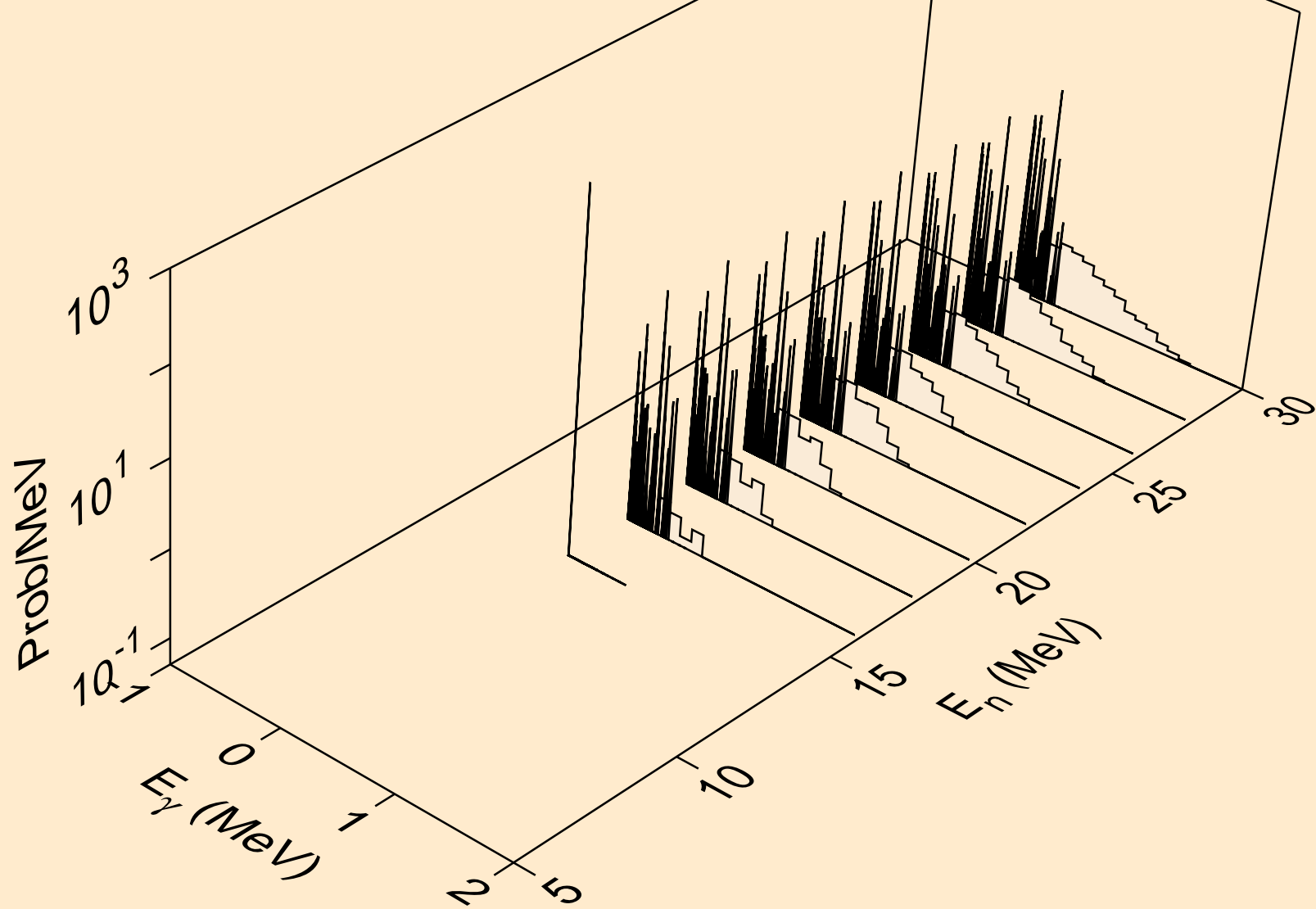

YB184 PROTON ACER TENDL-2024 LIBRARY; T=0.K  
Photon emission for (n,n\*)p

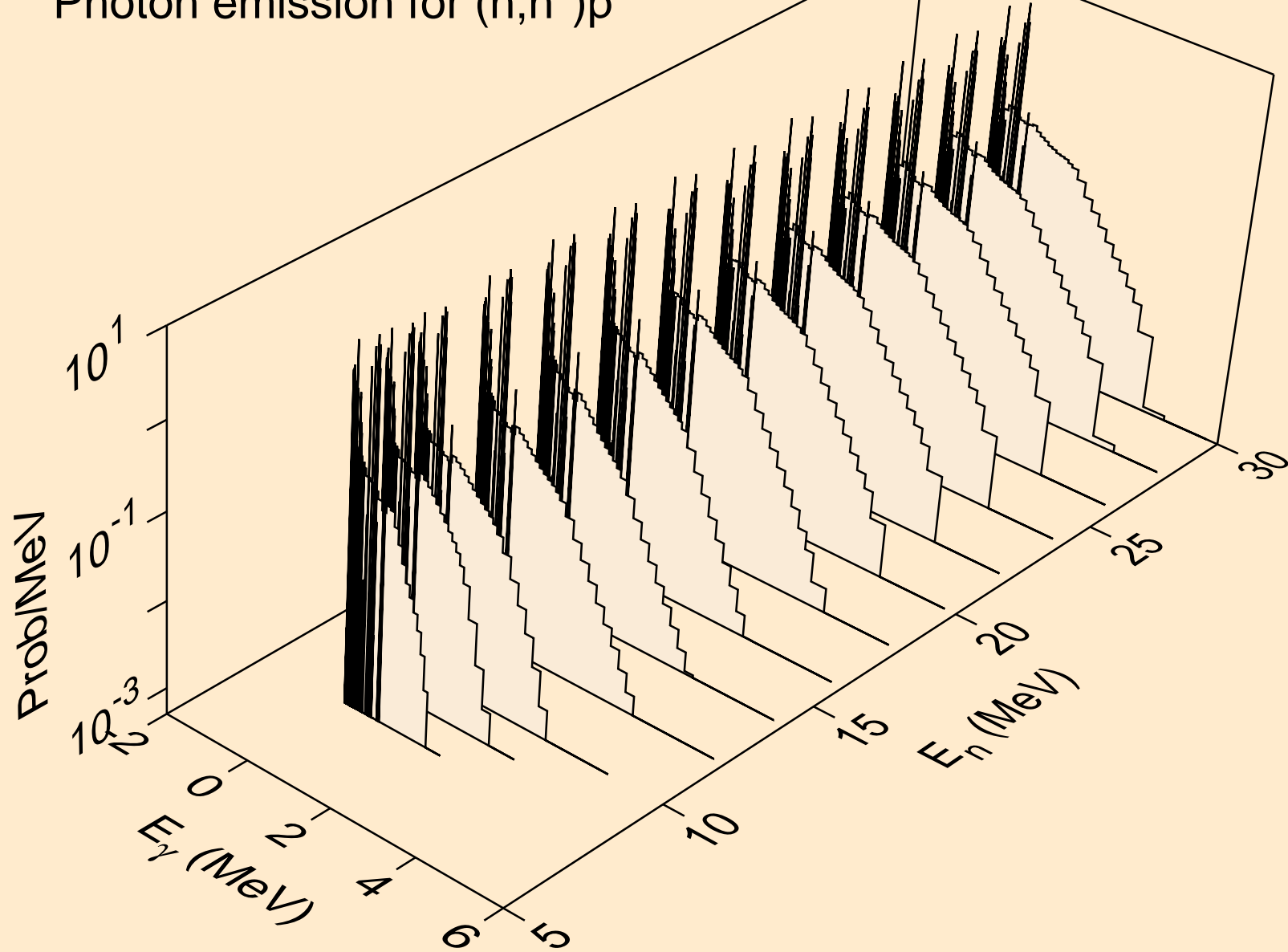

YB184 PROTON ACER TENDL-2024 LIBRARY; T=0.K  
Photon emission for (n,n\*)d

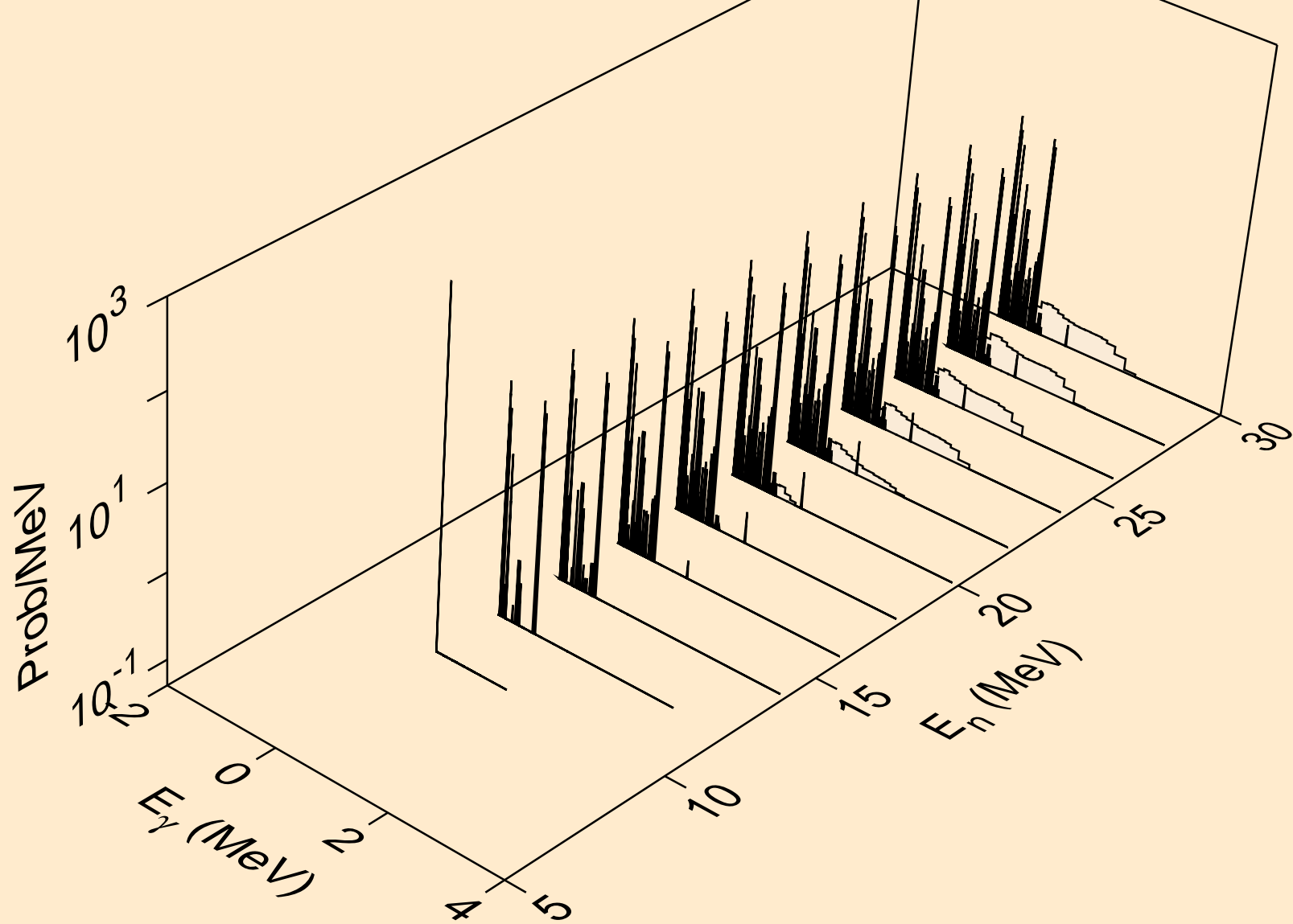

YB184 PROTON ACER TENDL-2024 LIBRARY; T=0.K  
Photon emission for (n,n\*)t

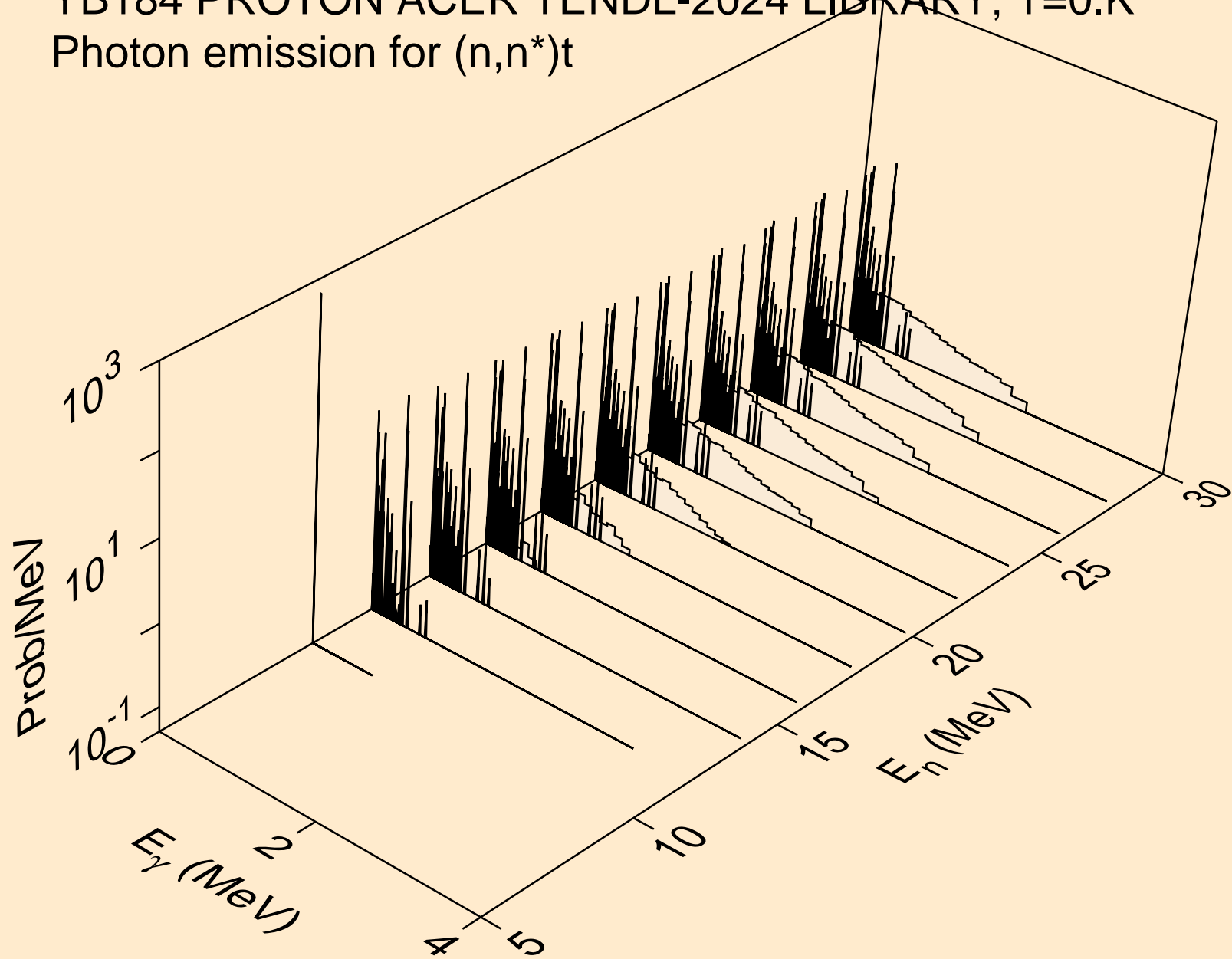

YB184 PROTON ACER TENDL-2024 LIBRARY; T=0.K  
Photon emission for (n,n\*)he3

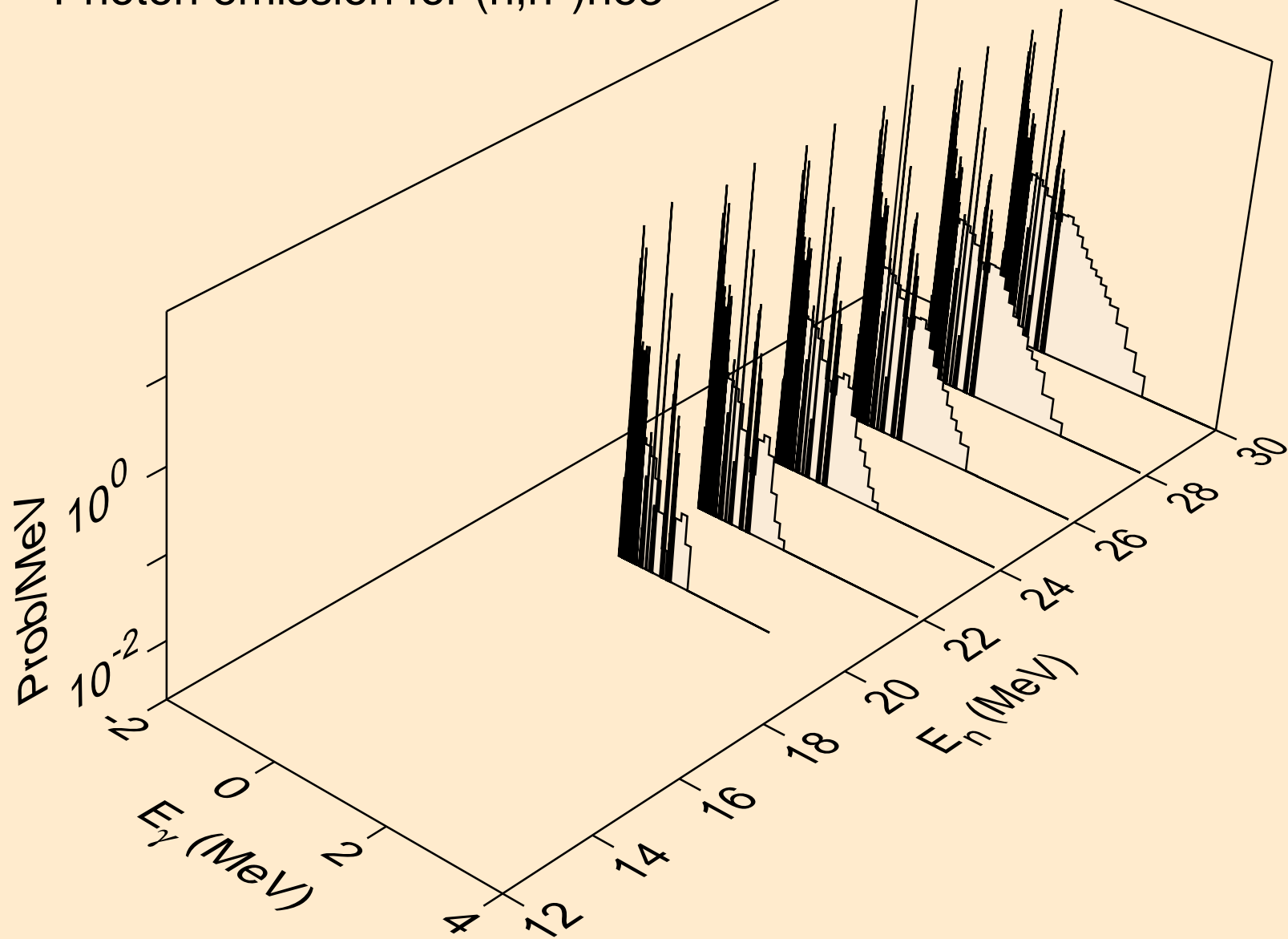

YB184 PROTON ACER TENDL-2024 LIBRARY; T=0.K  
Photon emission for (n,4n)

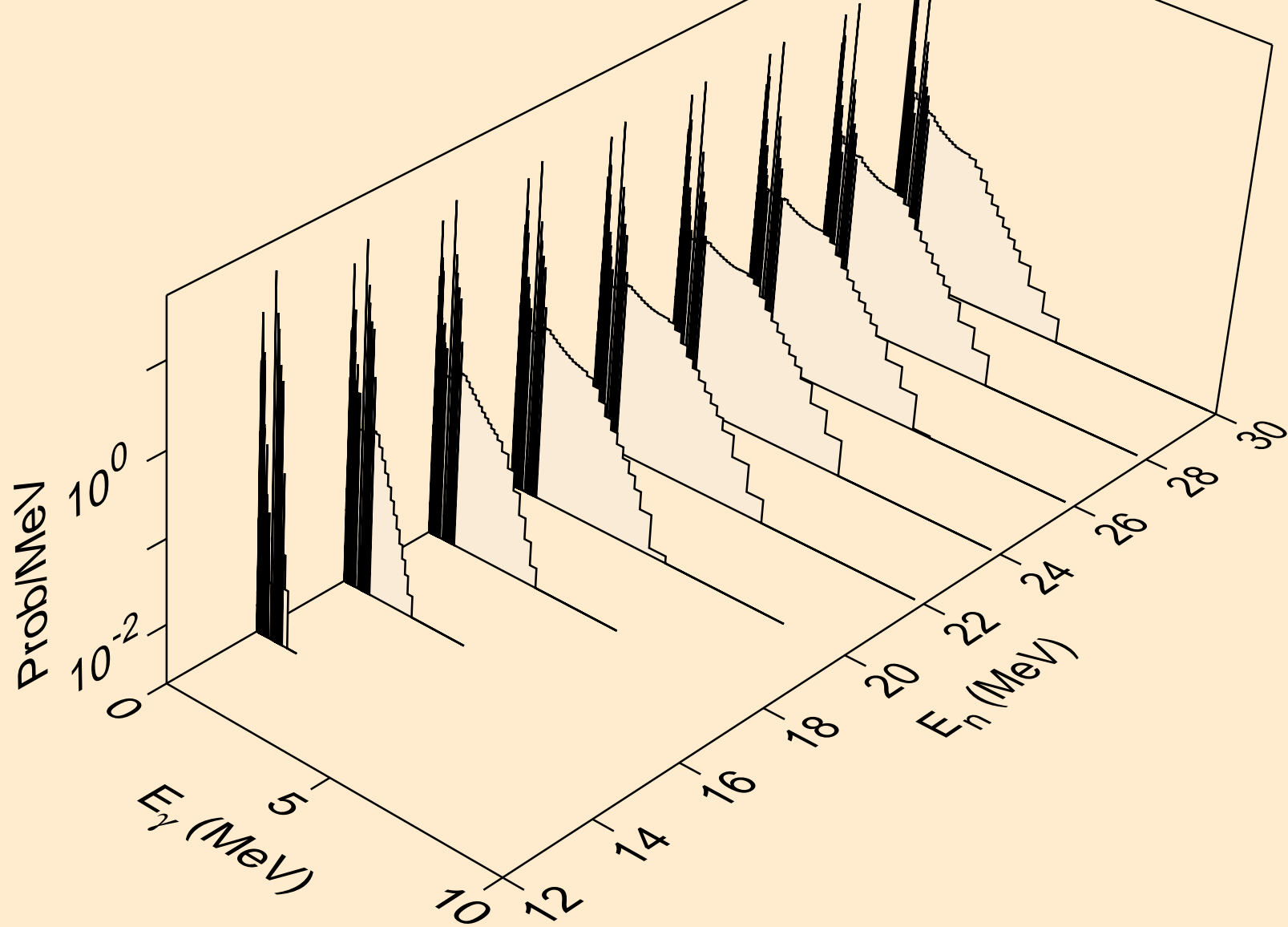

YB184 PROTON ACER TENDL-2024 LIBRARY; T=0.K  
Photon emission for (n,2np)

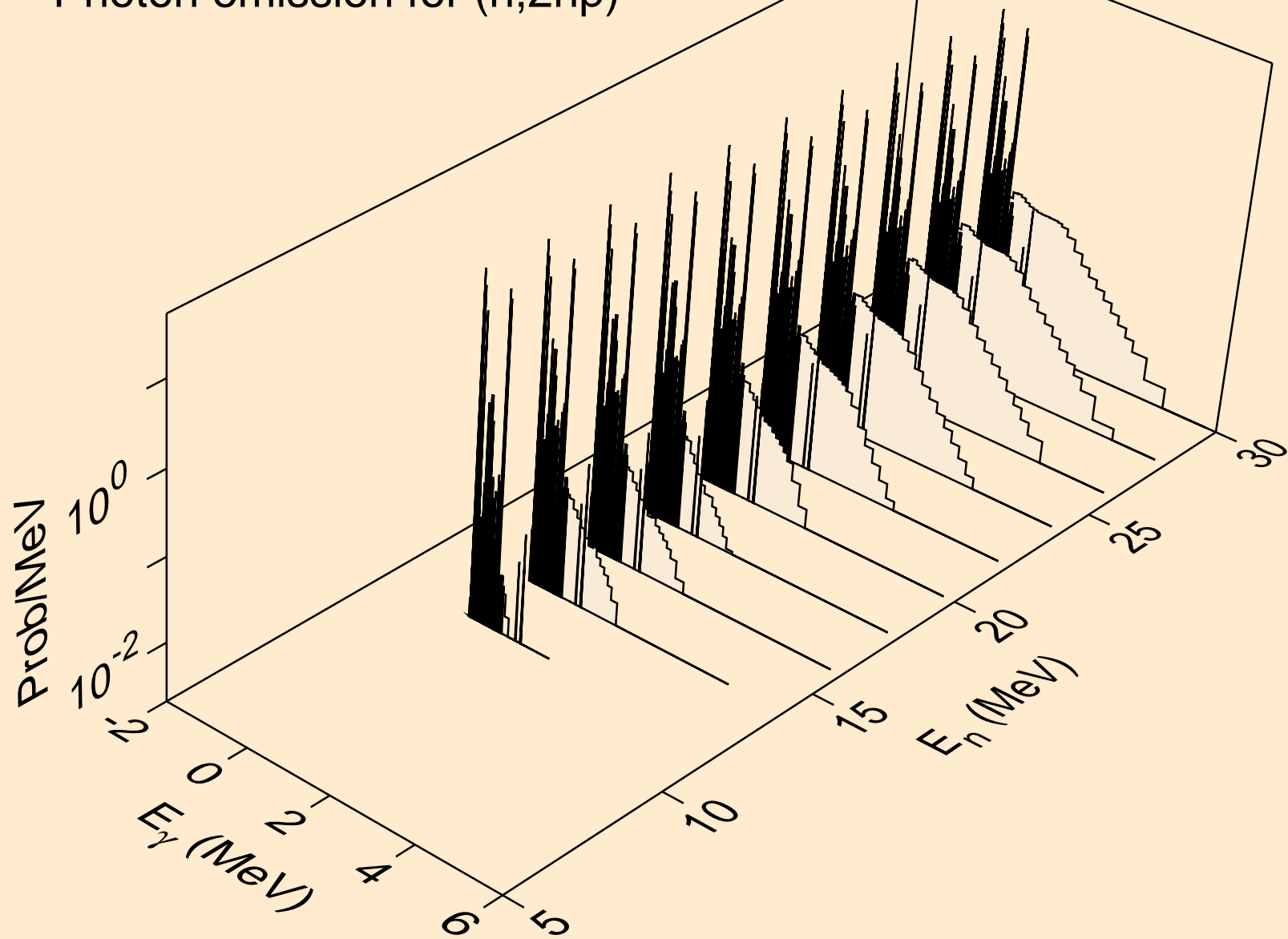

YB184 PROTON ACER TENDL-2024 LIBRARY; T=0.K  
Photon emission for (n,3np)

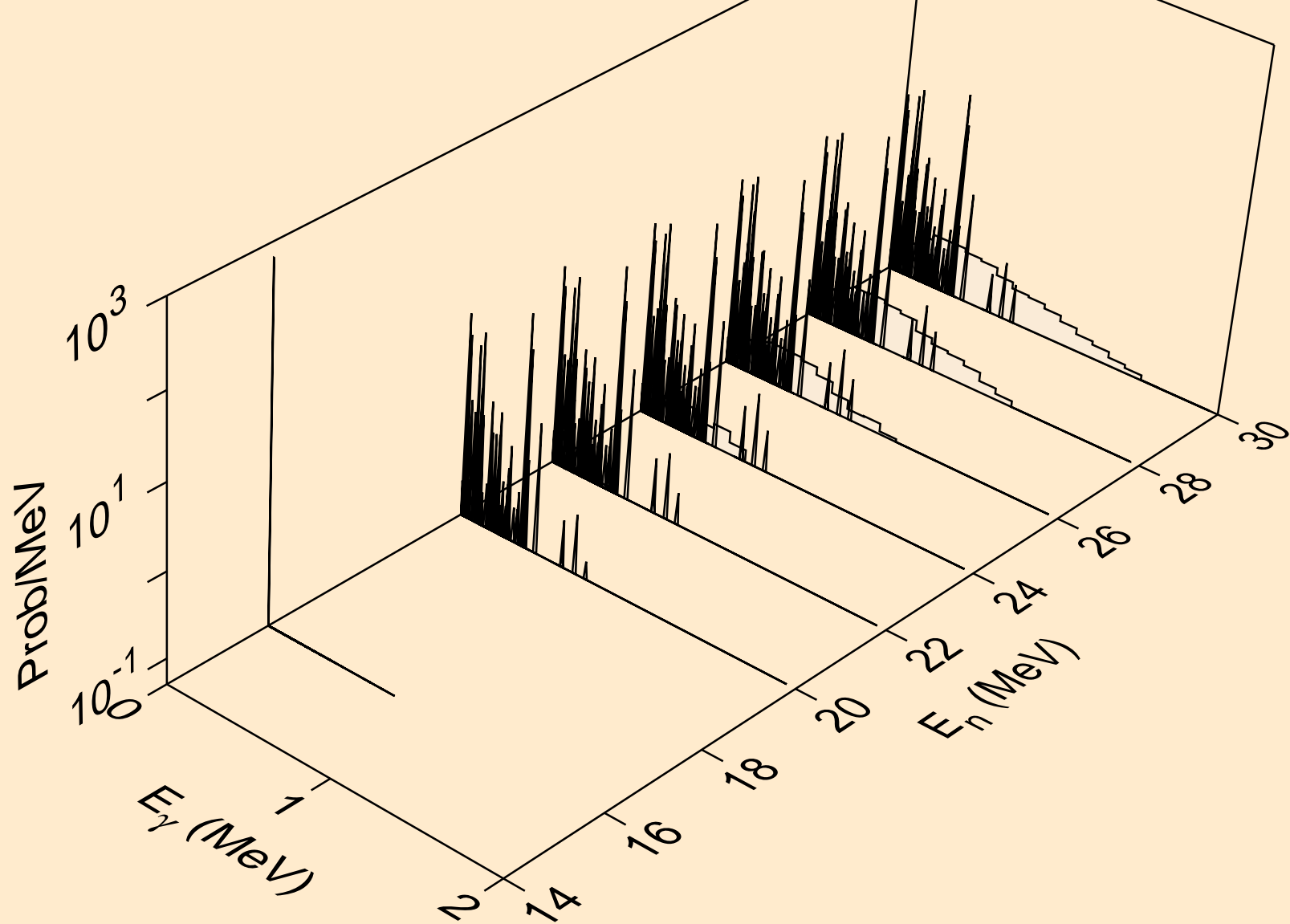

YB184 PROTON ACER TENDL-2024 LIBRARY; T=0.K  
Photon emission for (n,n2p)

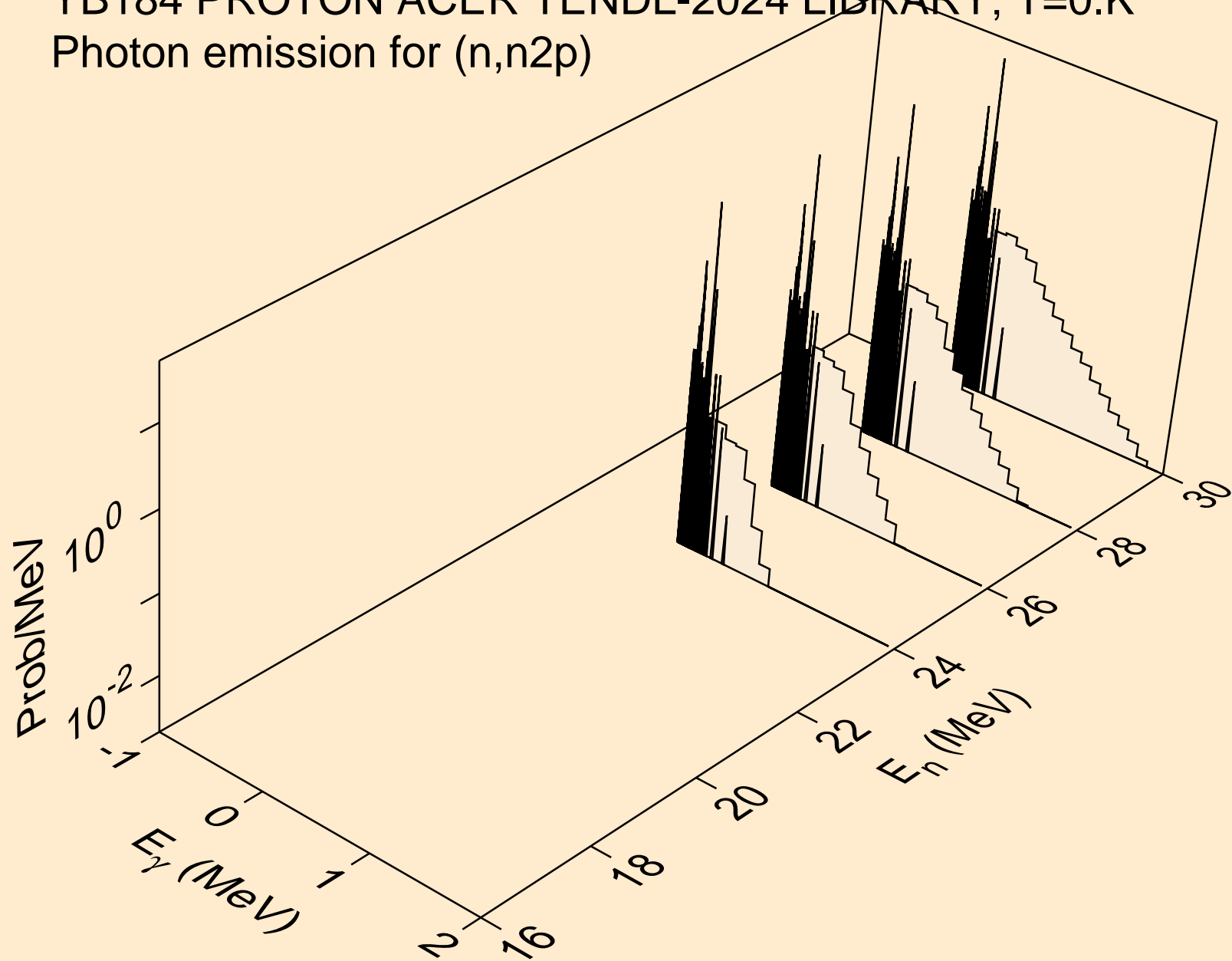

YB184 PROTON ACER TENDL-2024 LIBRARY; T=0.K  
Photon emission for (n,gma)

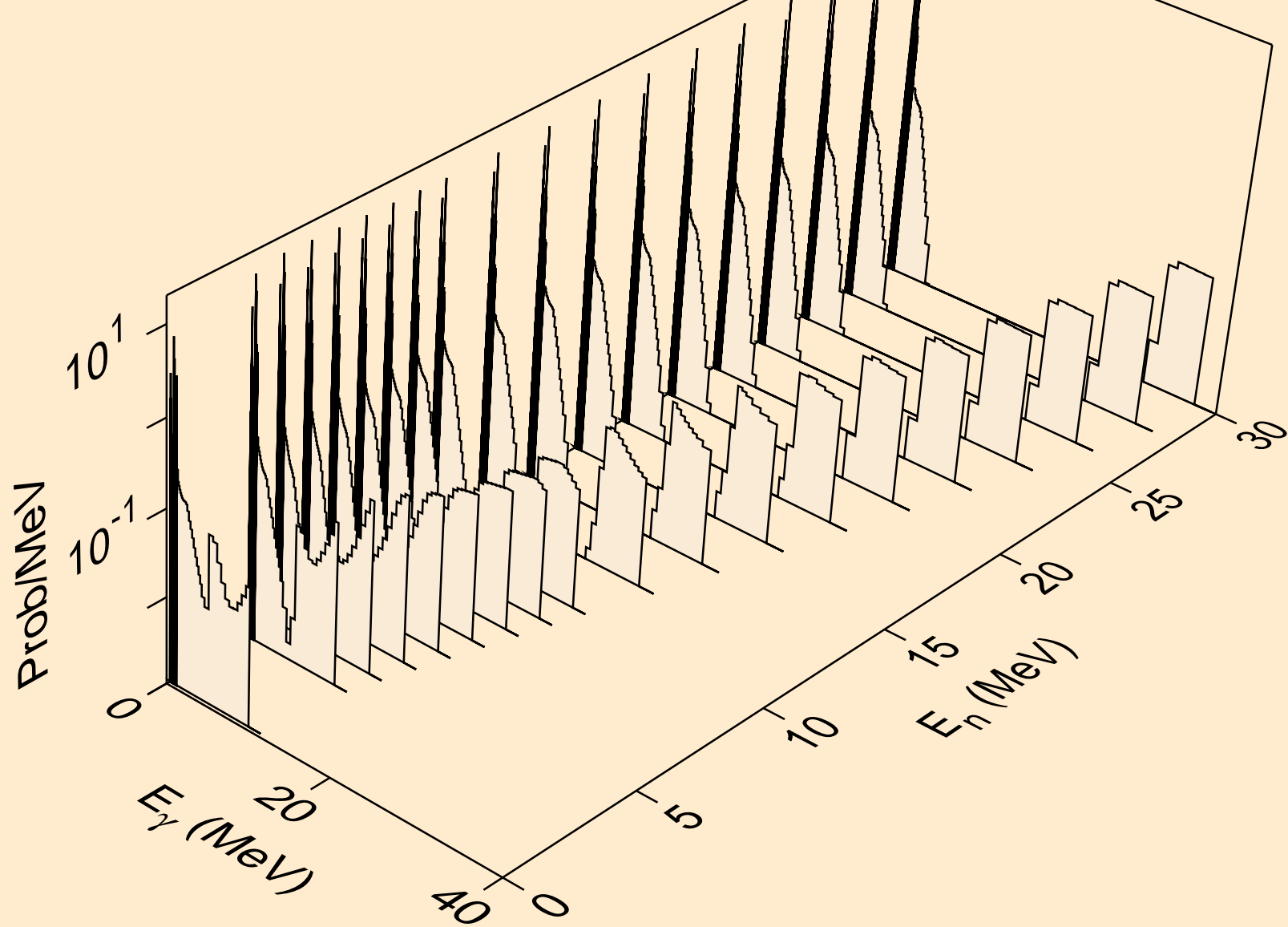

YB184 PROTON ACER TENDL-2024 LIBRARY; T=0.K  
Photon emission for inelastic

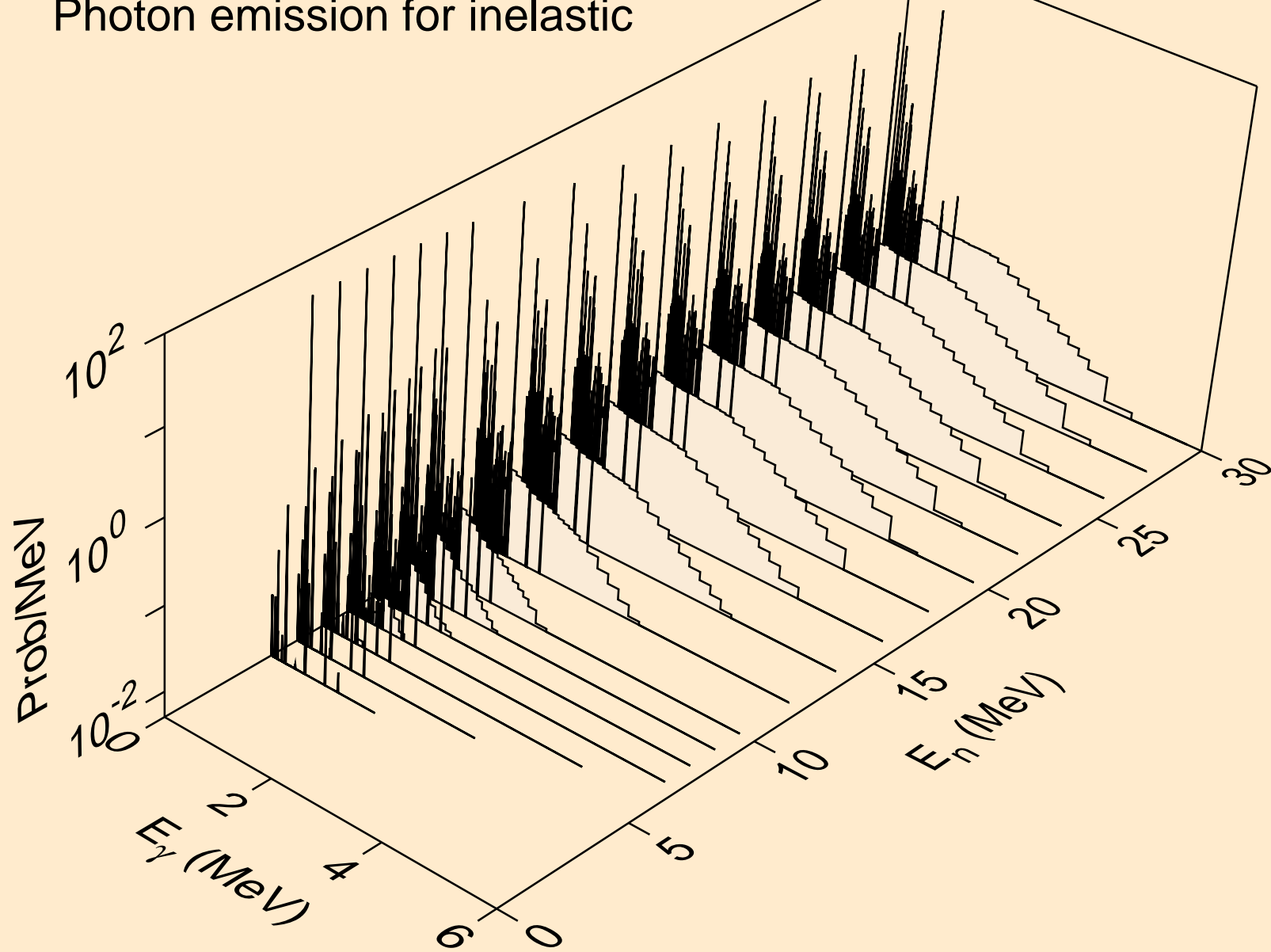

YB184 PROTON ACER TENDL-2024 LIBRARY; T=0.K  
Photon emission for (n,d)

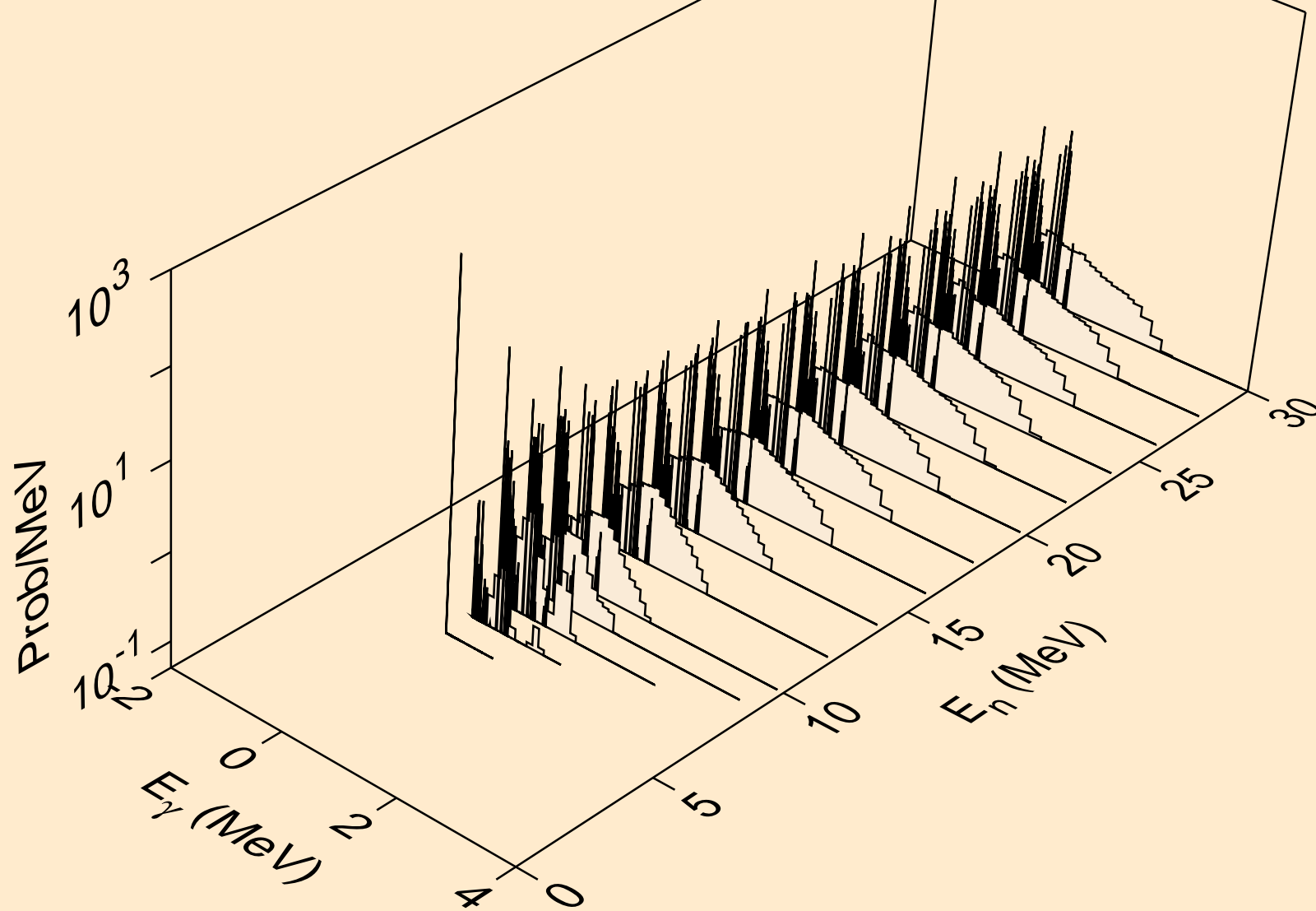

YB184 PROTON ACER TENDL-2024 LIBRARY; T=0.K  
Photon emission for (n,t)

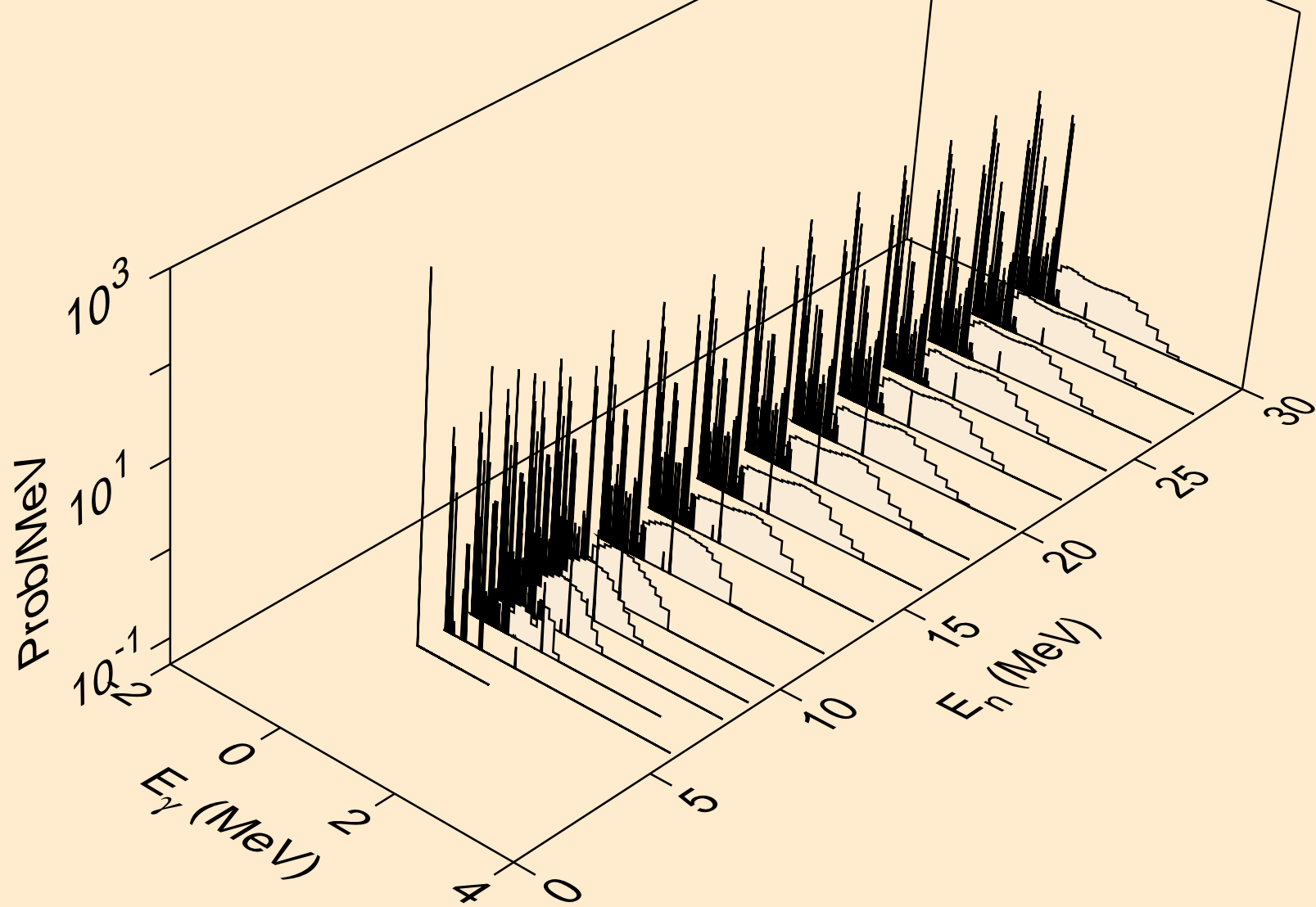

YB184 PROTON ACER TENDL-2024 LIBRARY; T=0.K  
Photon emission for (n,he3)

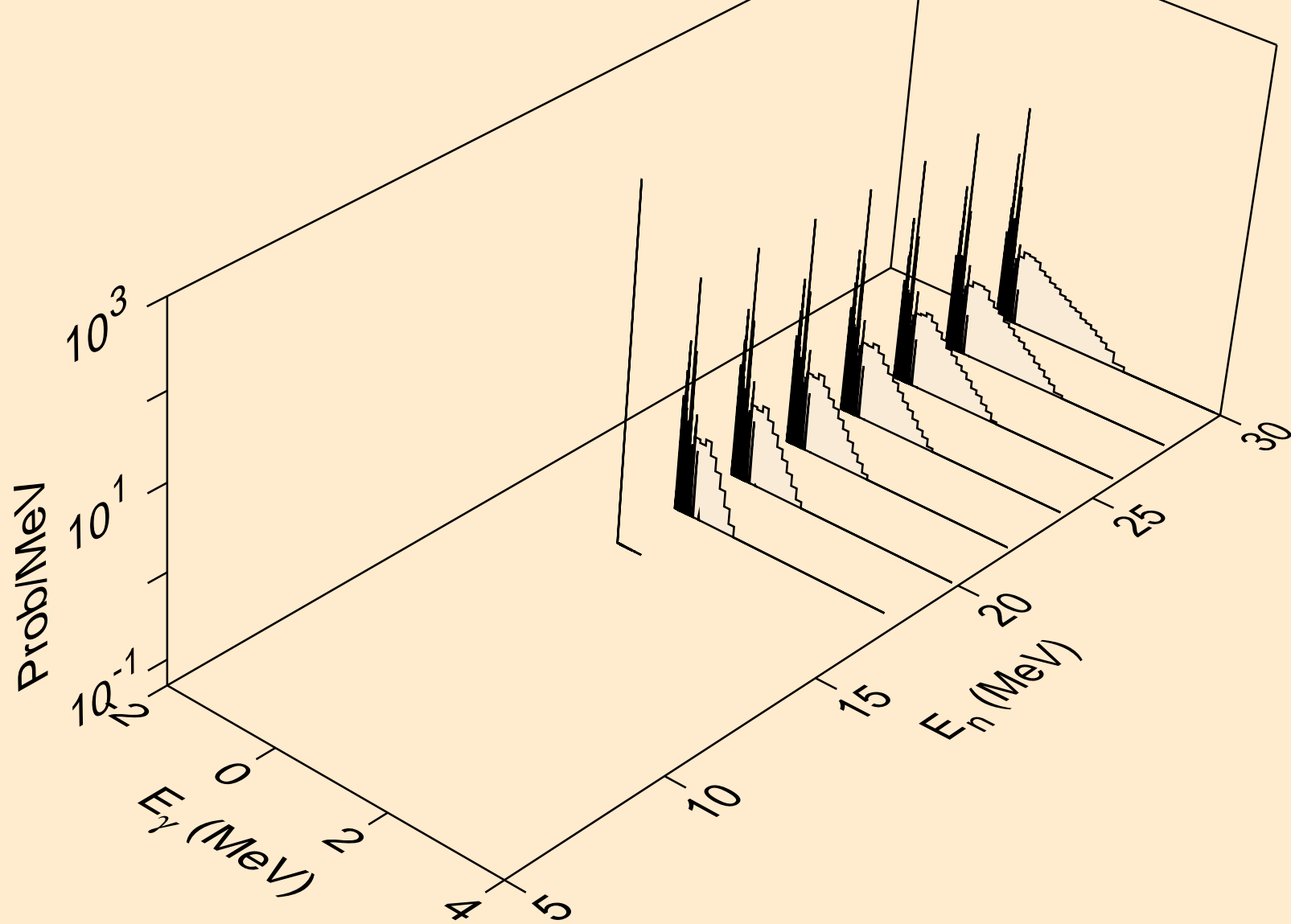

YB184 PROTON ACER TENDL-2024 LIBRARY; T=0.K  
Photon emission for (n,a)

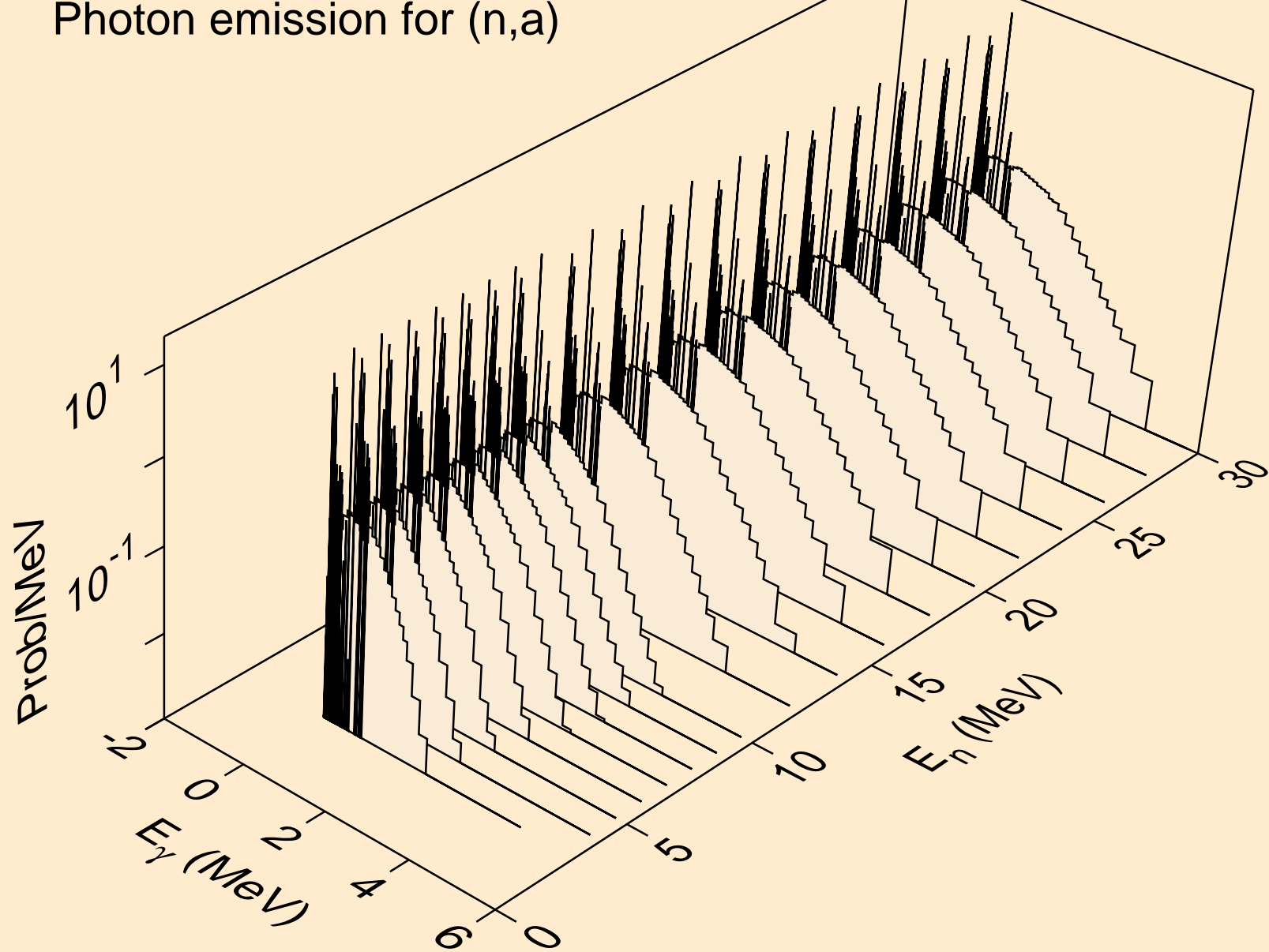

YB184 PROTON ACER TENDL-2024 LIBRARY; T=0.K  
Photon emission for (n,2p)

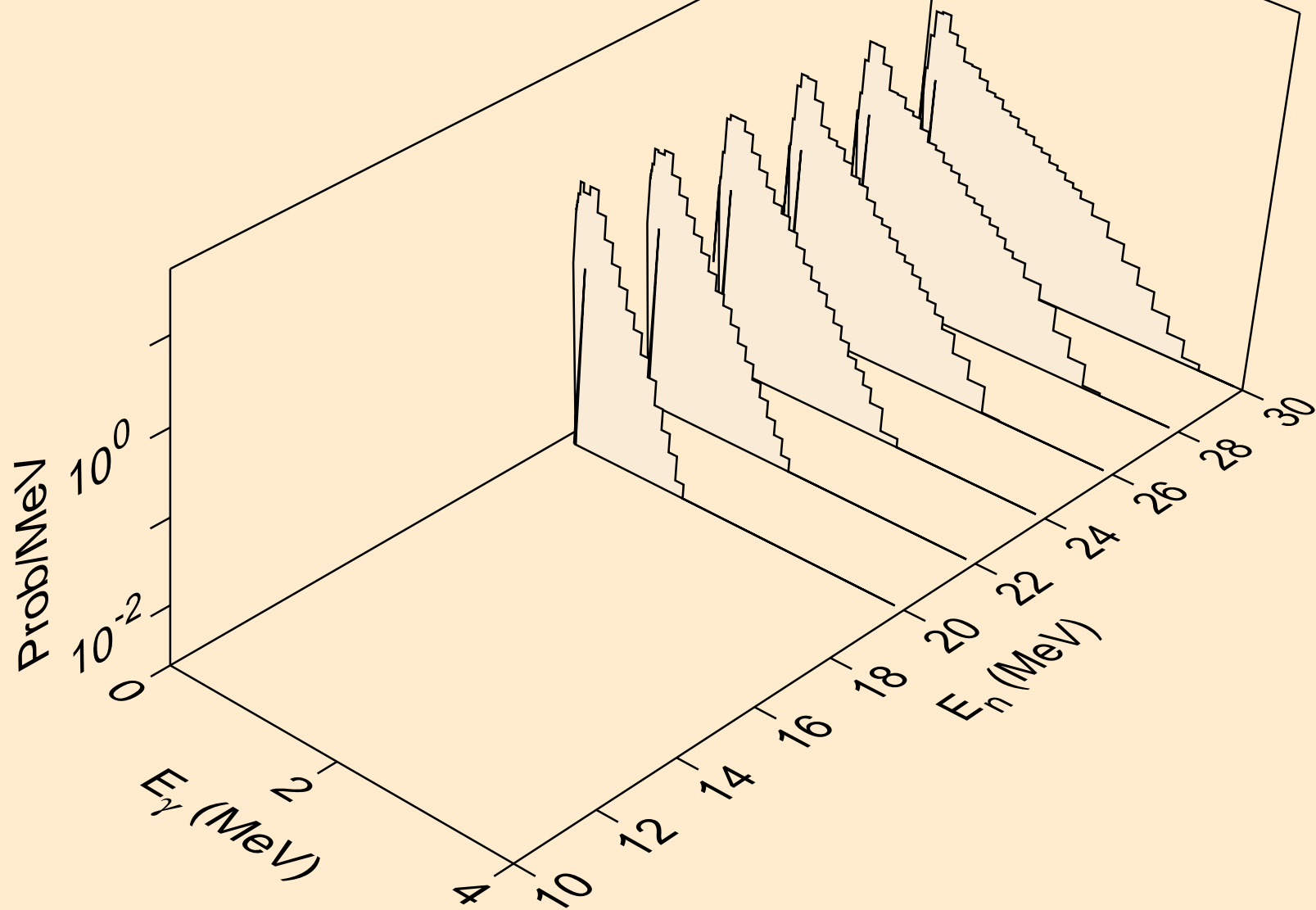

YB184 PROTON ACER TENDL-2024 LIBRARY; T=0.K  
Particle heating contributions

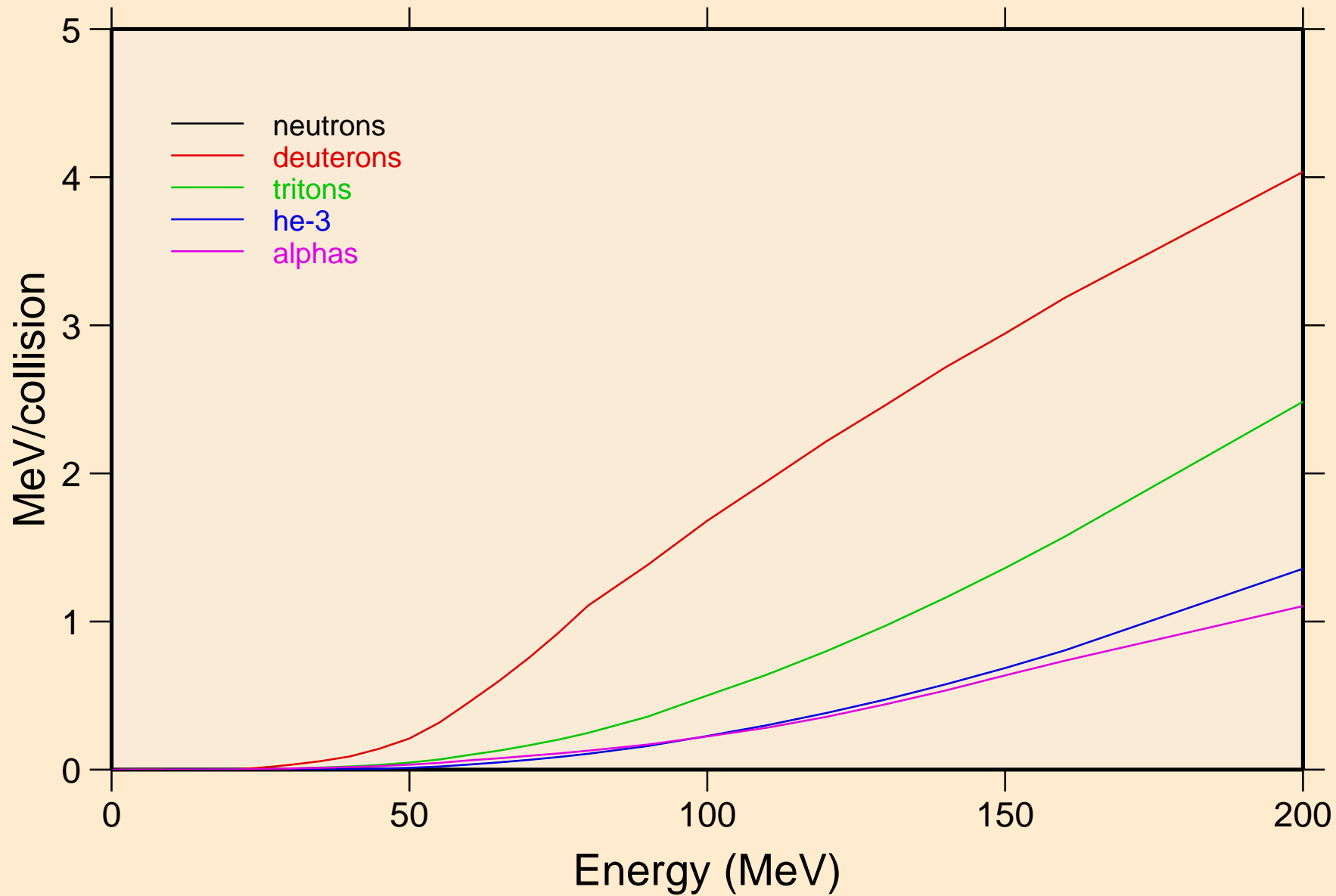

YB184 PROTON ACER TENDL-2024 LIBRARY; T=0.K  
Recoil Heating

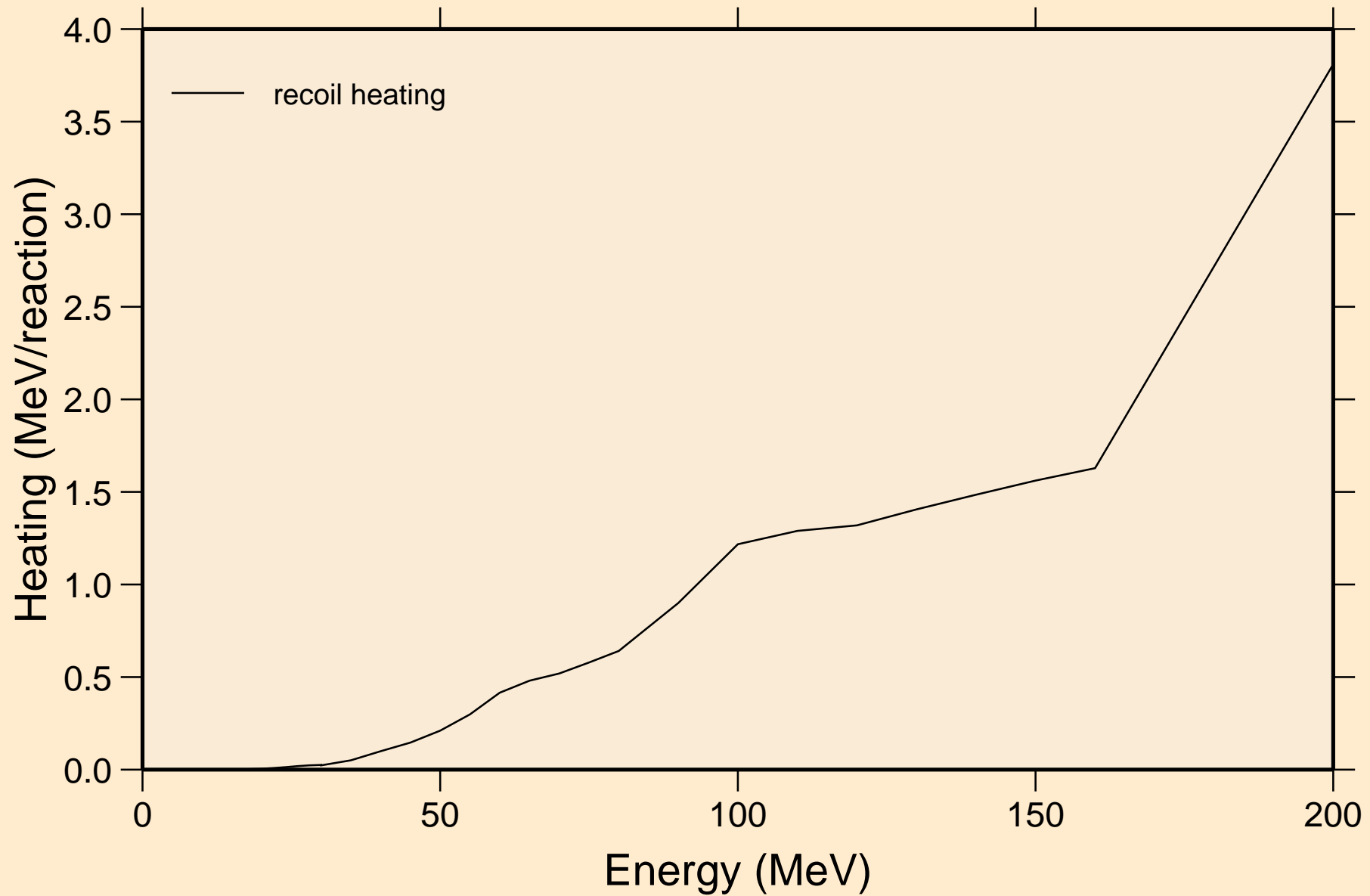

YB184 PROTON ACER TENDL-2024 LIBRARY; T=0.K  
Particle production cross sections

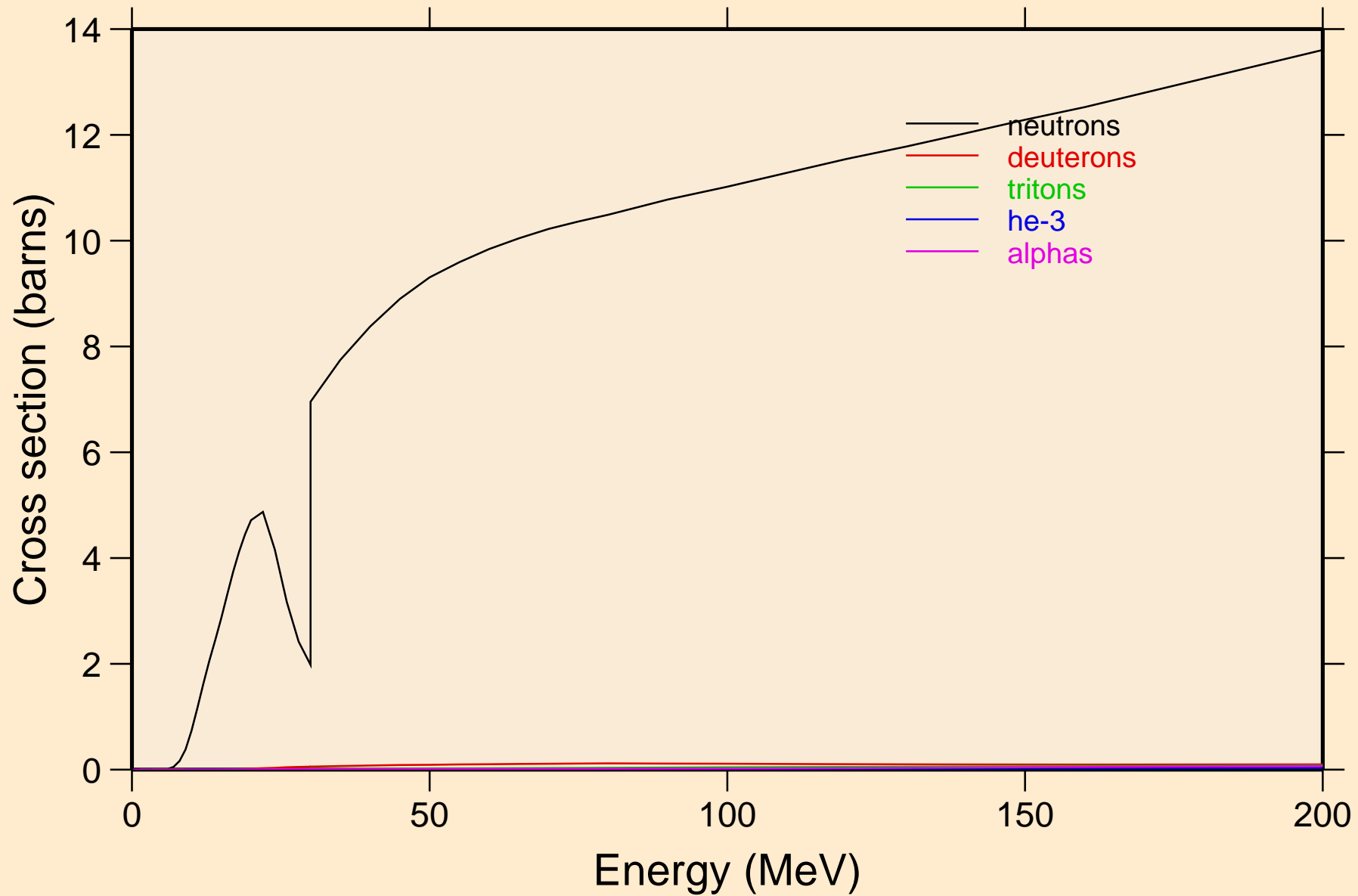

YB184 PROTON ACER TENDL-2024 LIBRARY; T=0.K  
neutrons from (p,n)

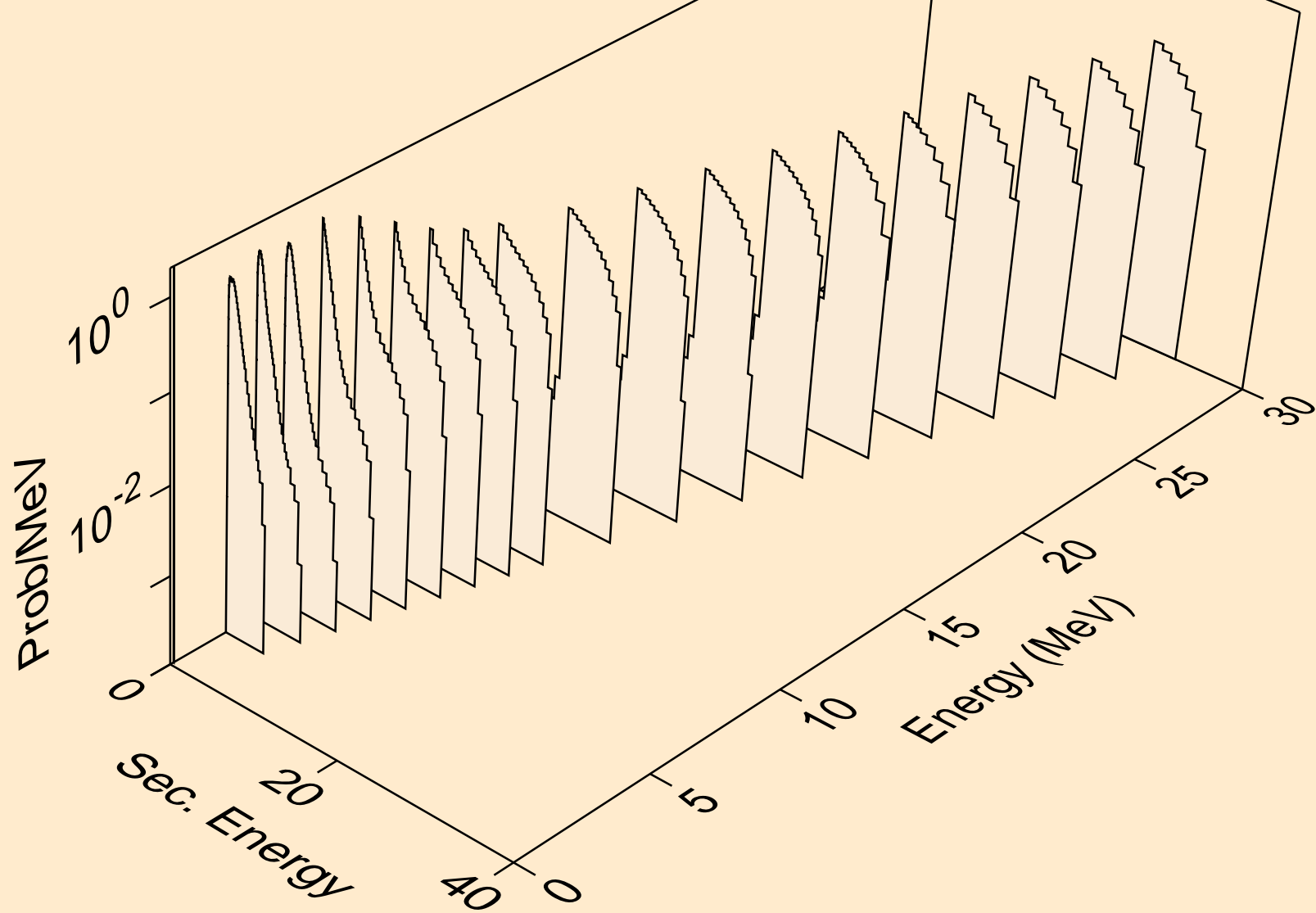

YB184 PROTON ACER TENDL-2024 LIBRARY; T=0.K  
neutrons from (p,x)

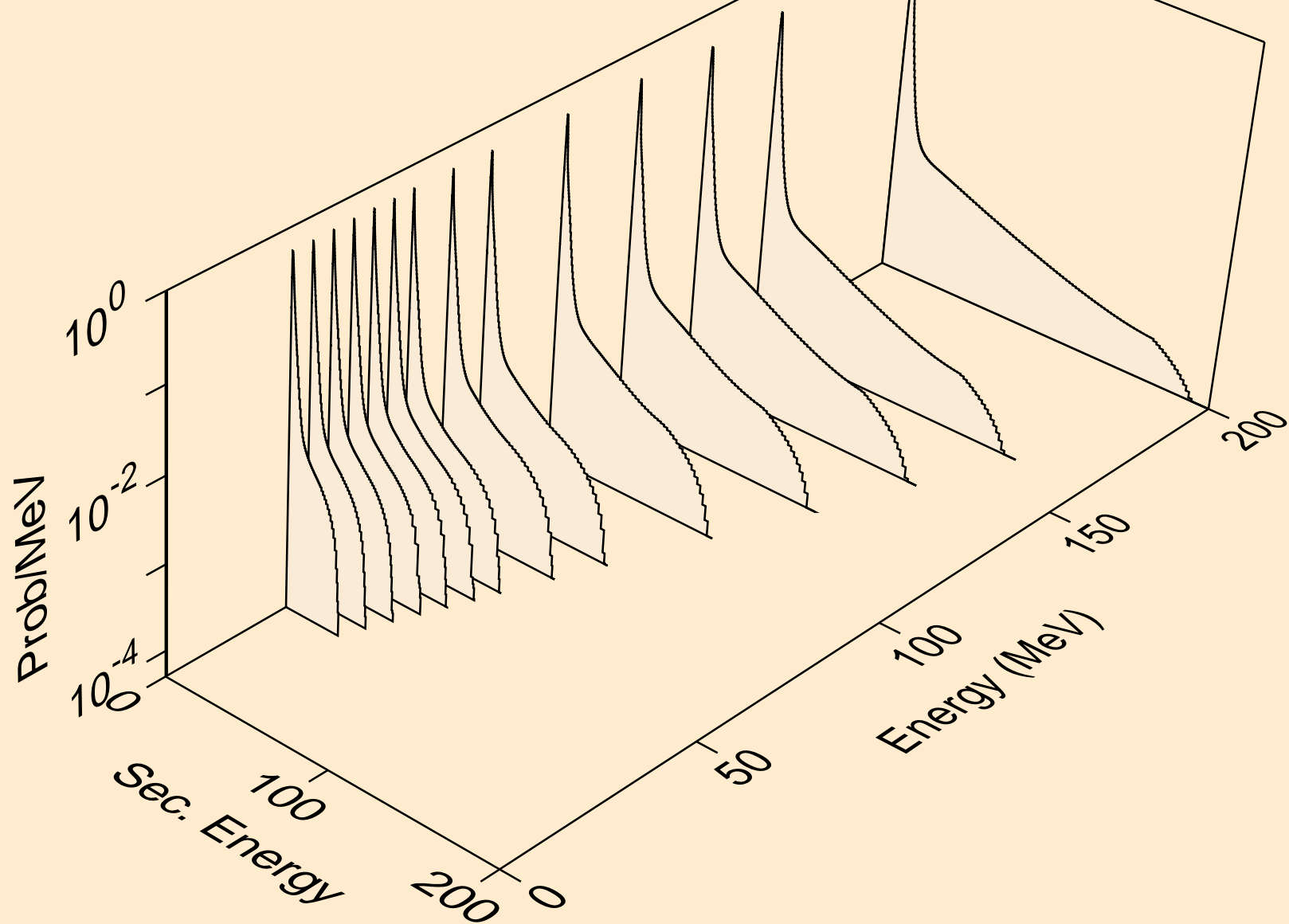

YB184 PROTON ACER TENDL-2024 LIBRARY; T=0.K  
neutrons from (p,2nd)

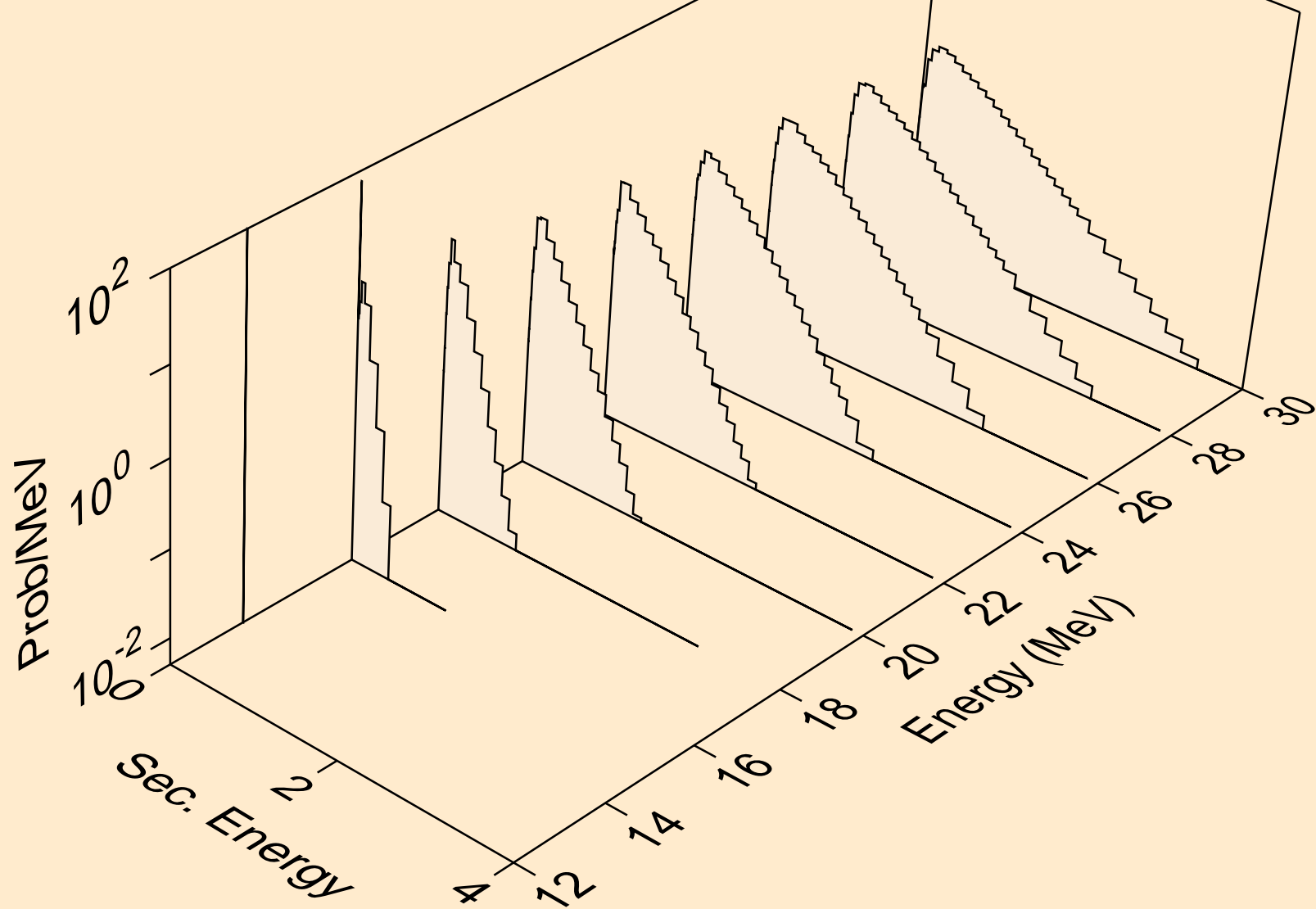

YB184 PROTON ACER TENDL-2024 LIBRARY; T=0.K  
neutrons from (p,2n)

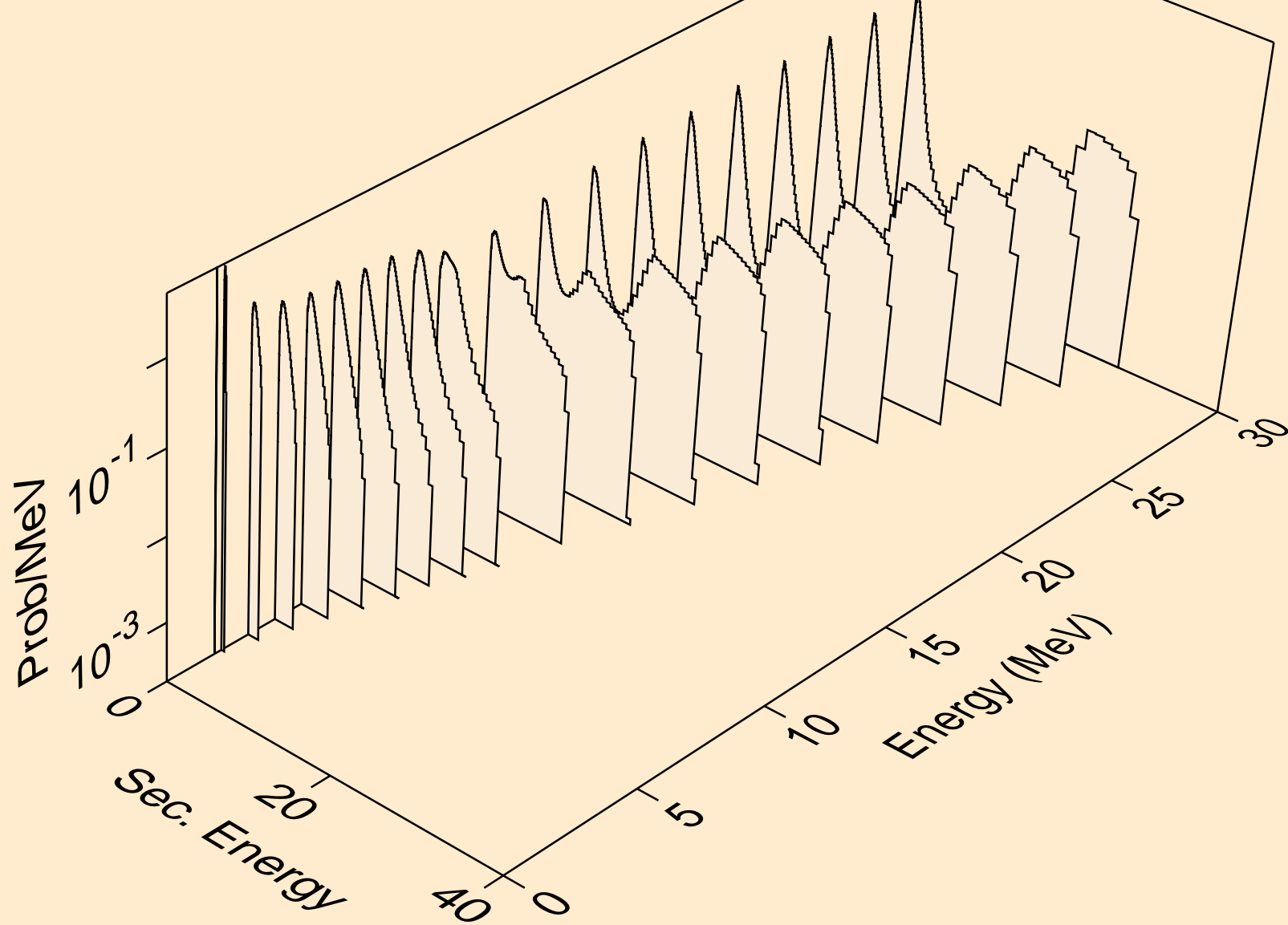

YB184 PROTON ACER TENDL-2024 LIBRARY; T=0.K  
neutrons from (p,3n)

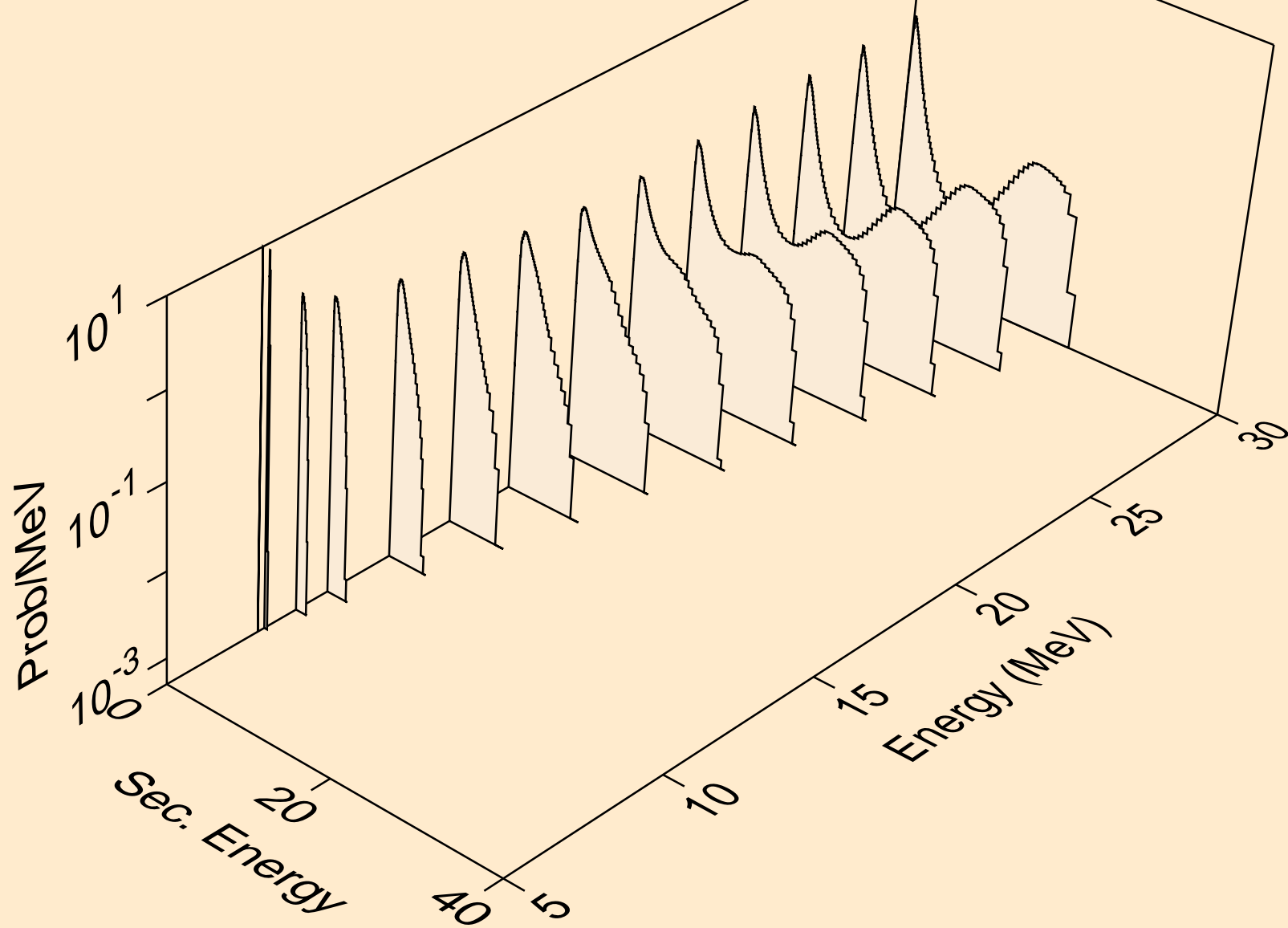

YB184 PROTON ACER TENDL-2024 LIBRARY; T=0.K  
neutrons from (p,n\*)a

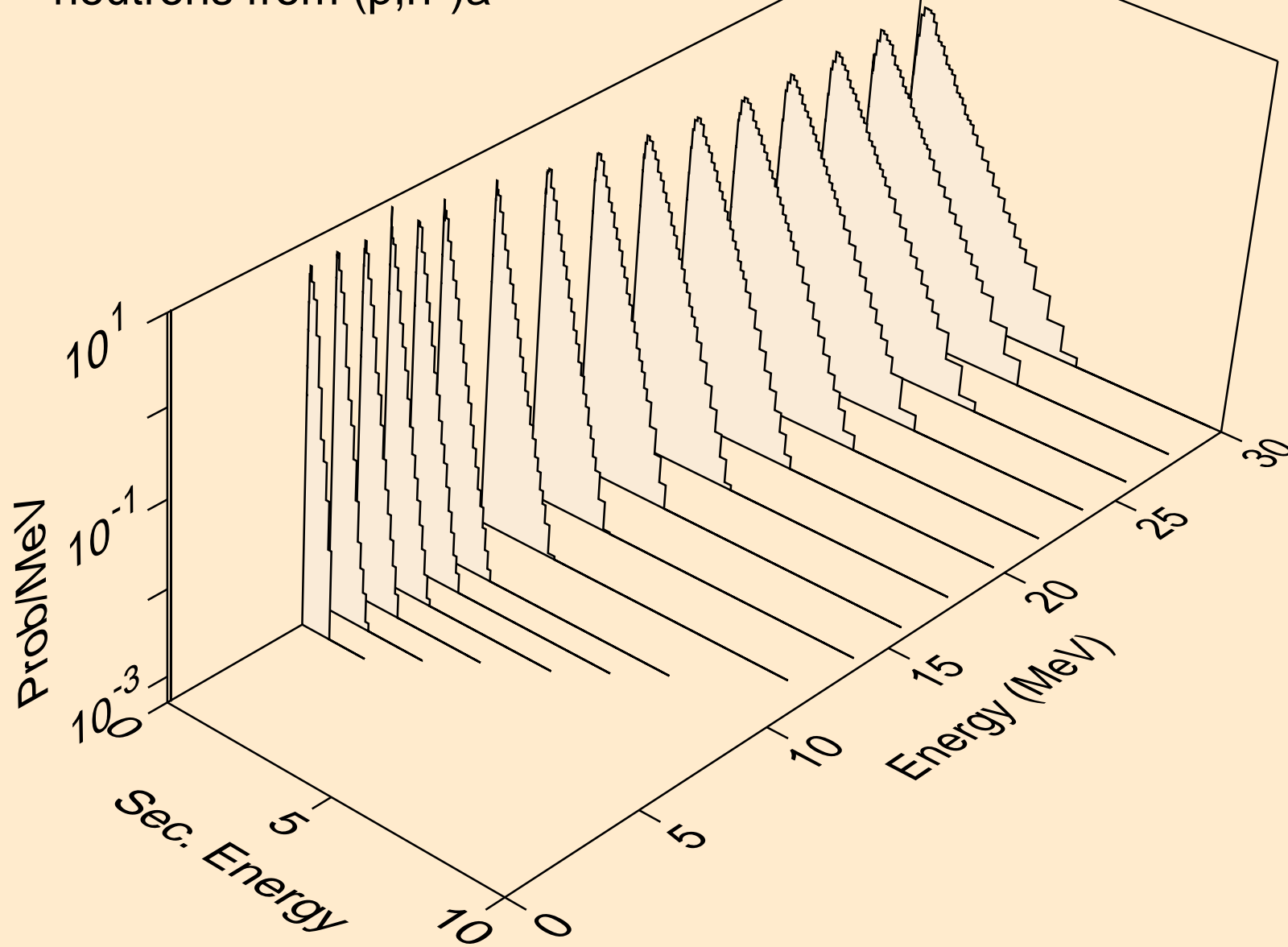

YB184 PROTON ACER TENDL-2024 LIBRARY; T=0.K  
neutrons from (p,2n)a

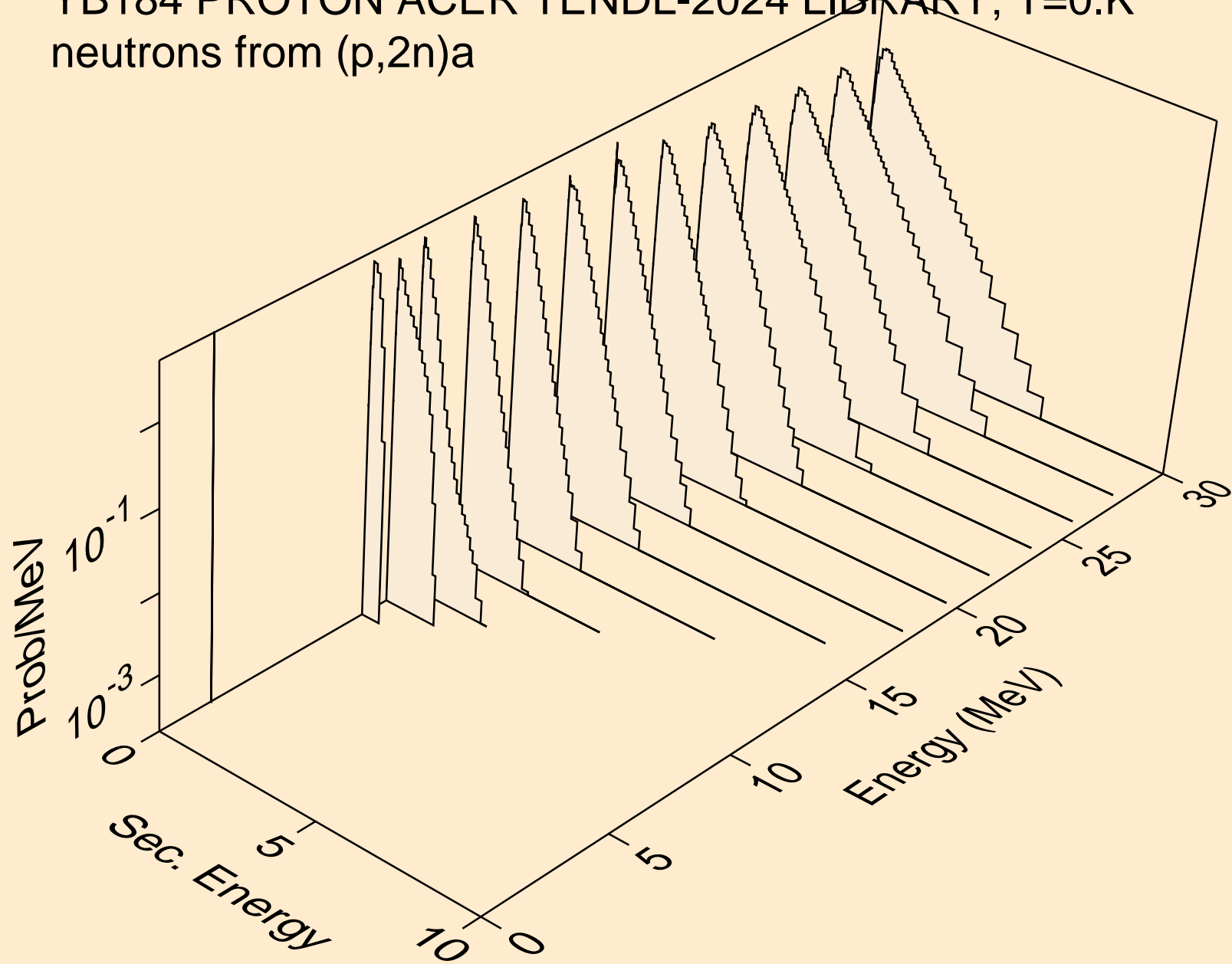

YB184 PROTON ACER TENDL-2024 LIBRARY; T=0.K  
neutrons from (p,3n)a

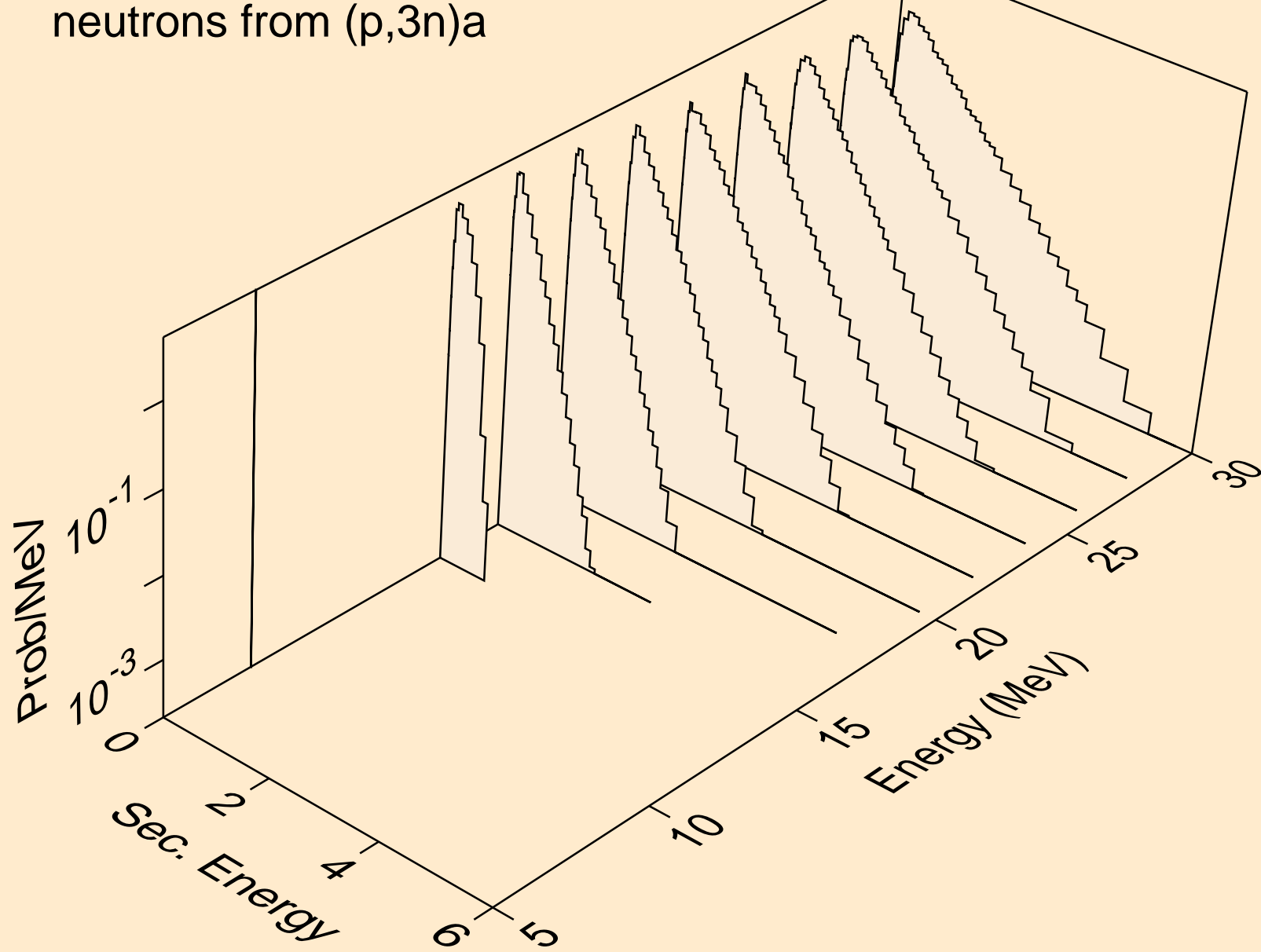

YB184 PROTON ACER TENDL-2024 LIBRARY; T=0.K  
neutrons from (p,n\*)p

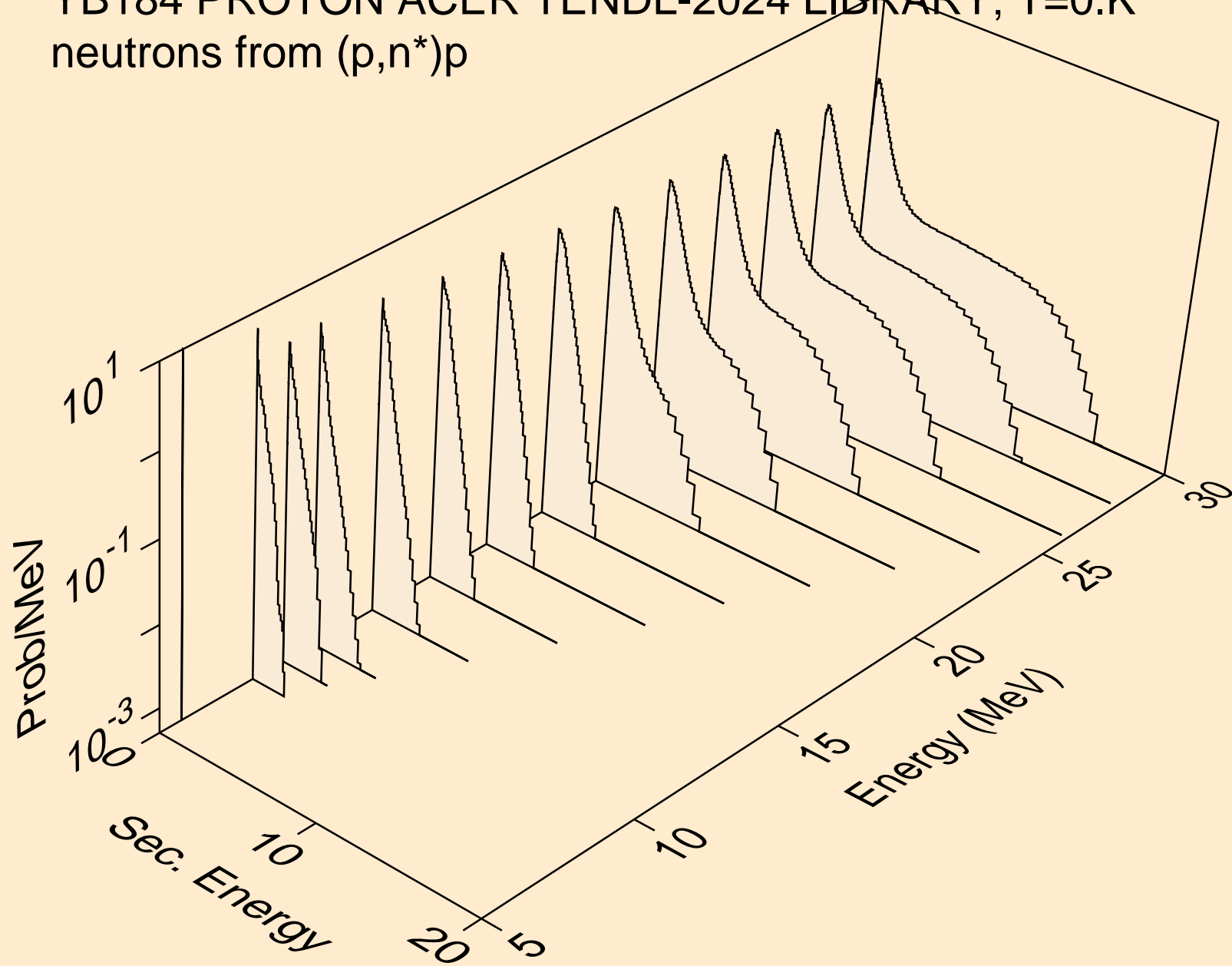

YB184 PROTON ACER TENDL-2024 LIBRARY; T=0.K  
neutrons from (p,n\*)d

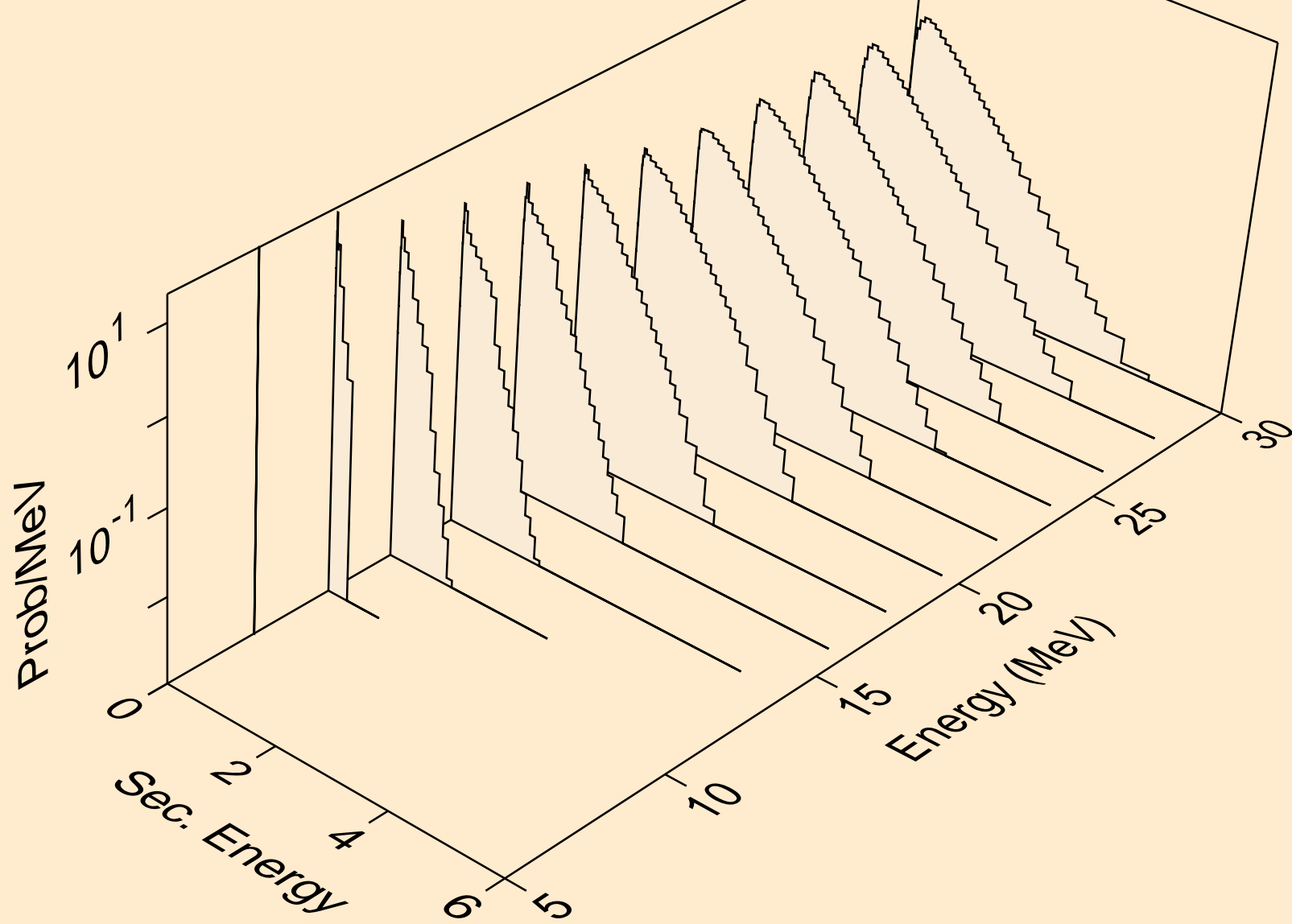

YB184 PROTON ACER TENDL-2024 LIBRARY; T=0.K  
neutrons from (p,n\*)t

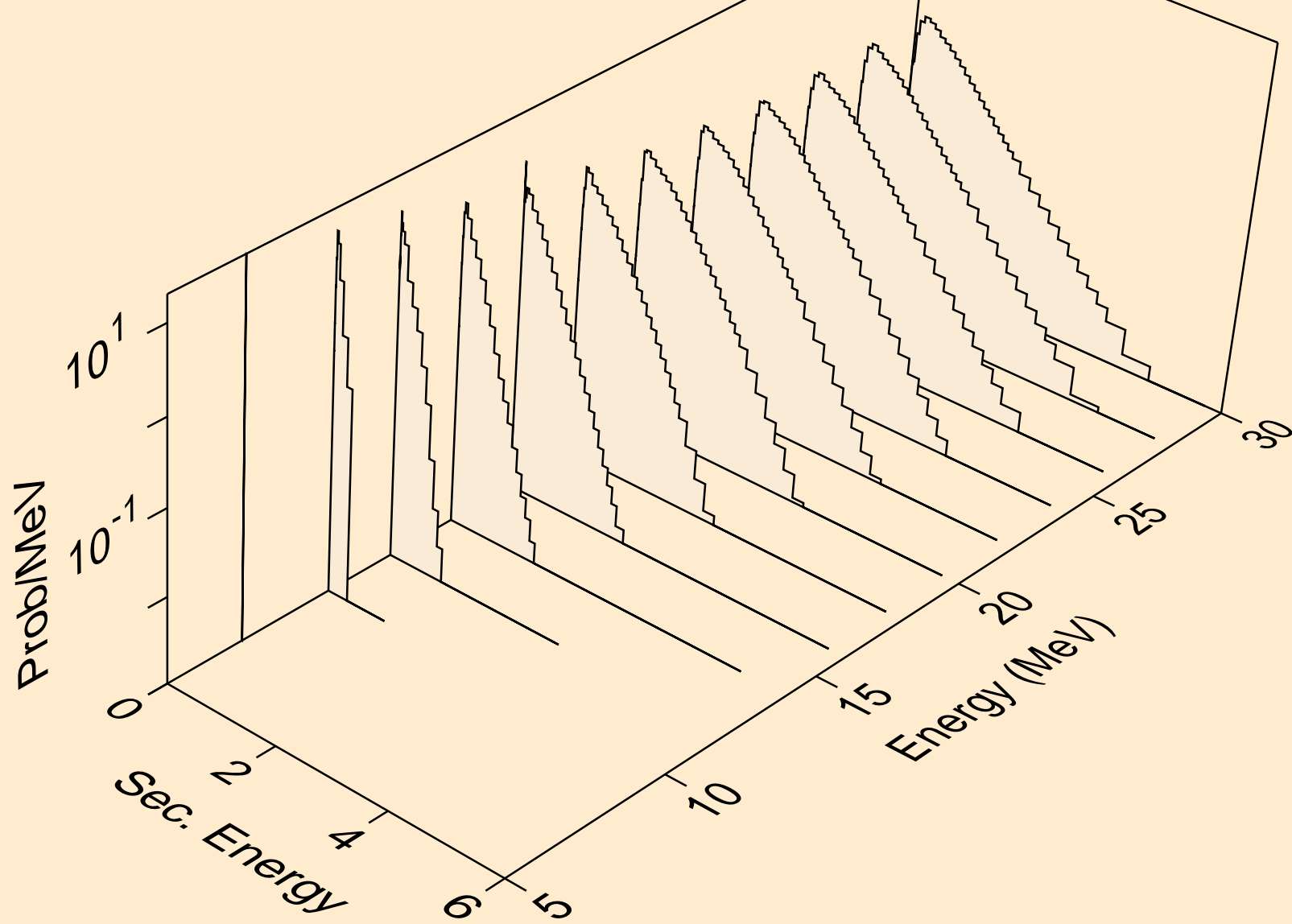

YB184 PROTON ACER TENDL-2024 LIBRARY; T=0.K  
neutrons from (p,n\*)he3

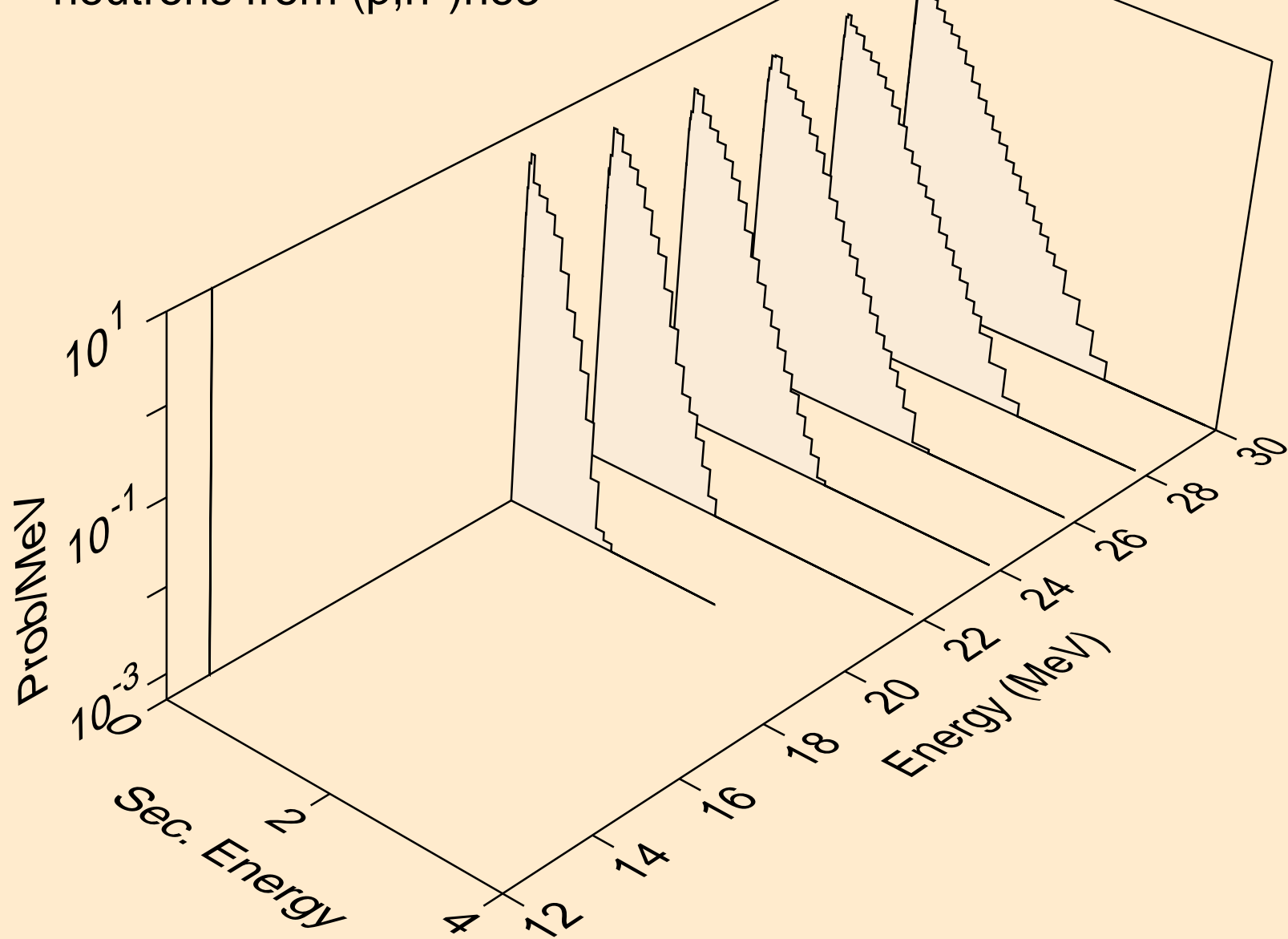

YB184 PROTON ACER TENDL-2024 LIBRARY; T=0.K  
neutrons from (p,4n)

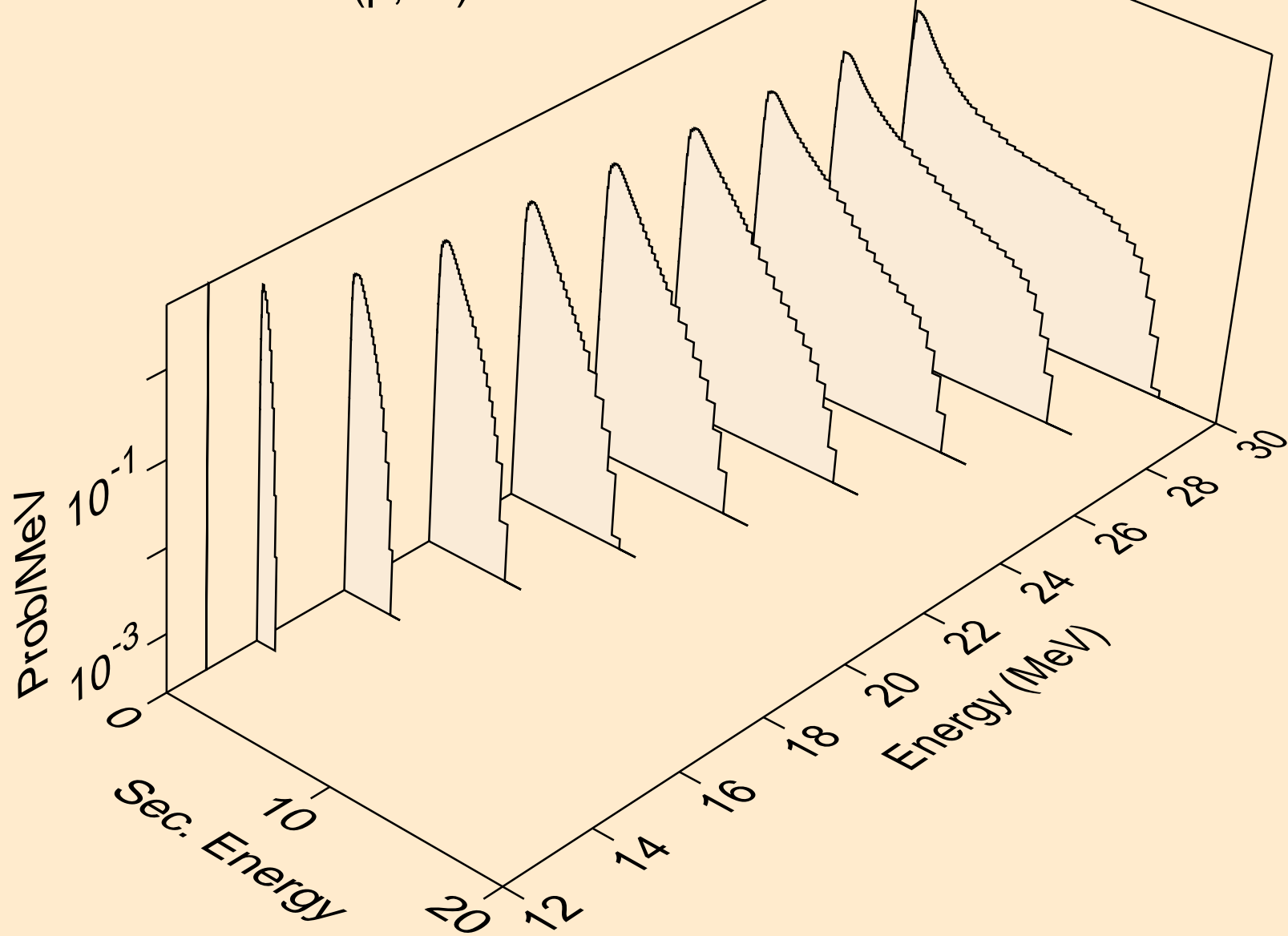

YB184 PROTON ACER TENDL-2024 LIBRARY; T=0.K  
neutrons from (p,2np)

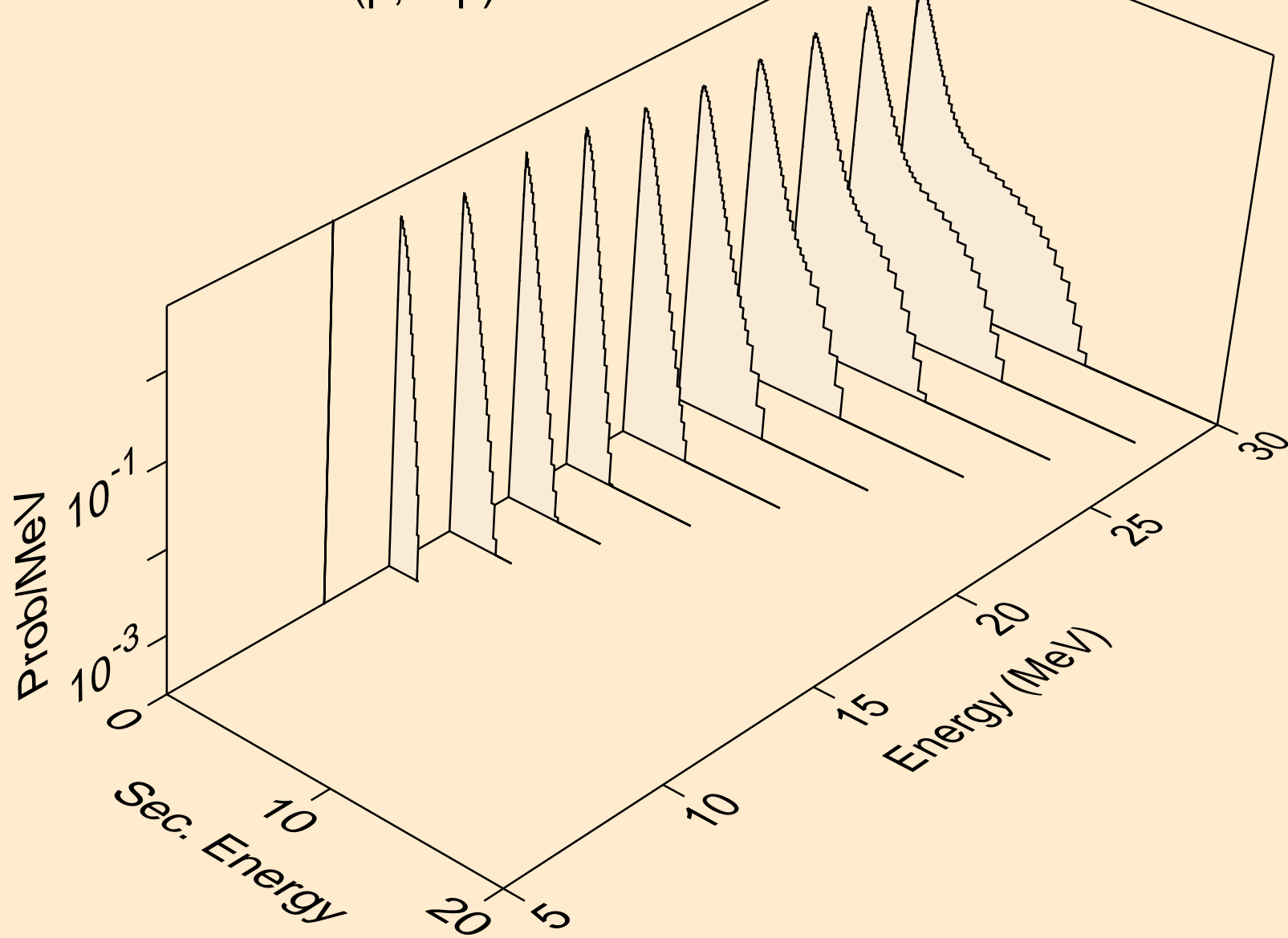

YB184 PROTON ACER TENDL-2024 LIBRARY; T=0.K  
neutrons from (p,3np)

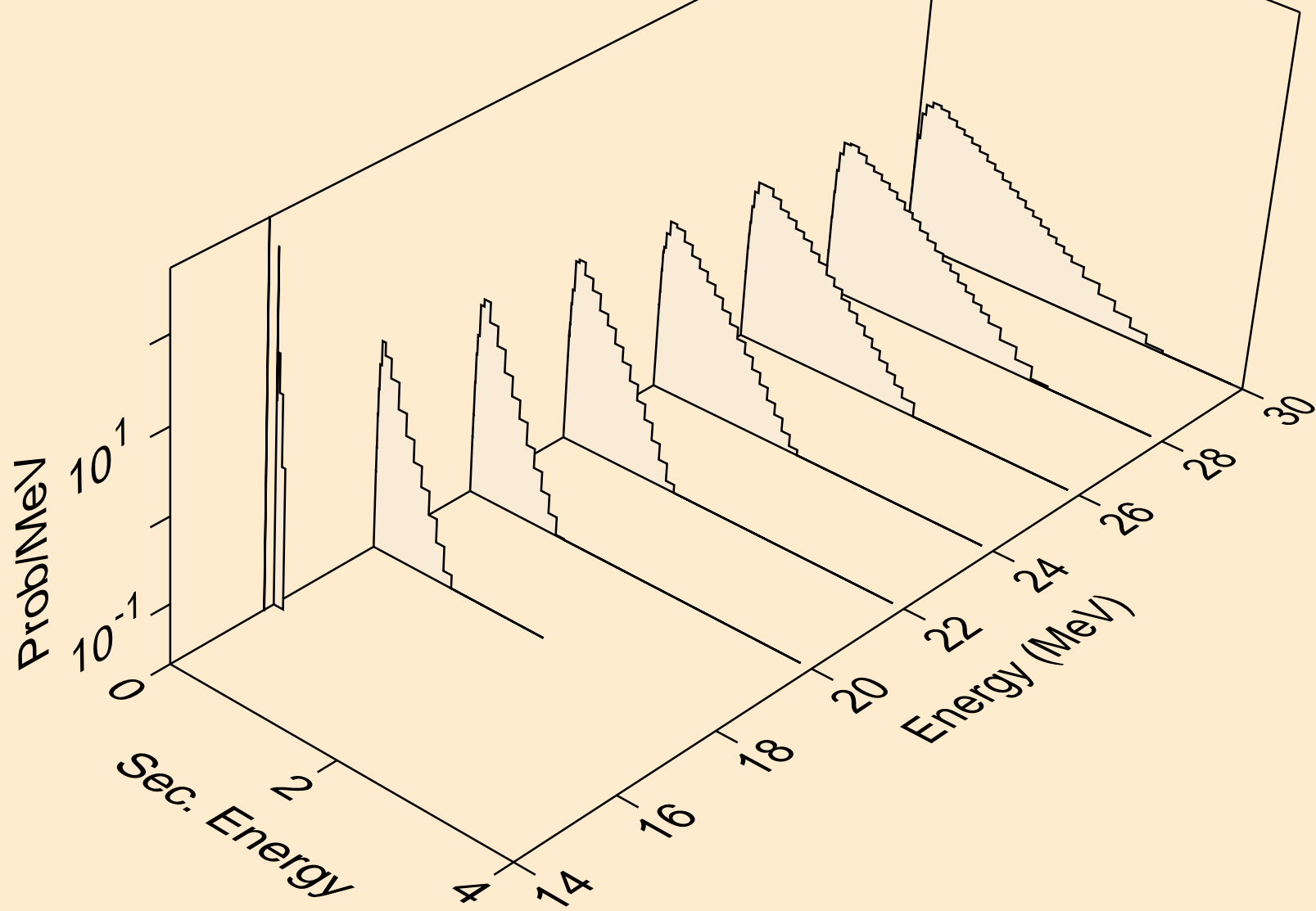

YB184 PROTON ACER TENDL-2024 LIBRARY; T=0.K  
neutrons from (p,n2p)

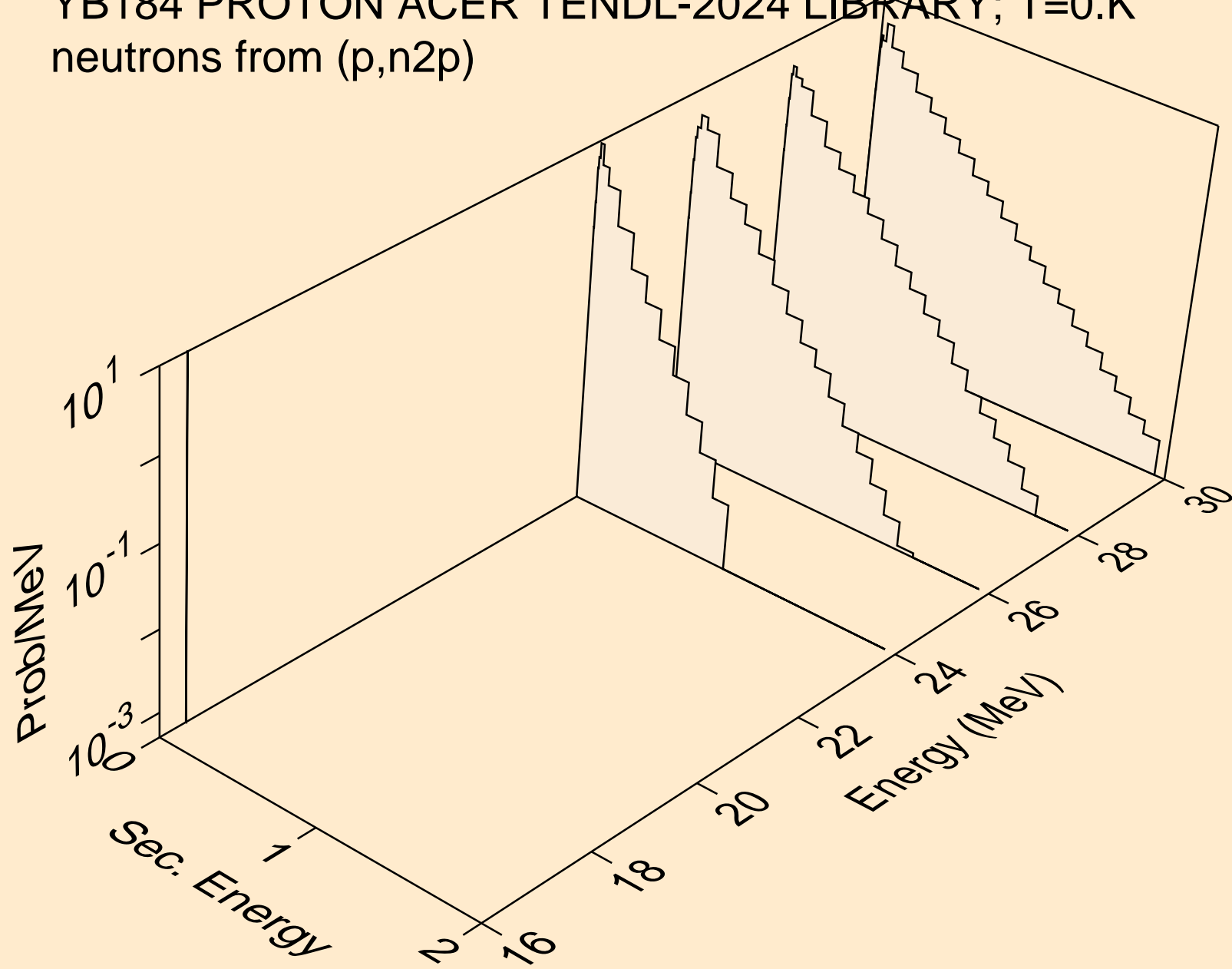

YB184 PROTON ACER TENDL-2024 LIBRARY; T=0.K  
deuterons from (p,x)

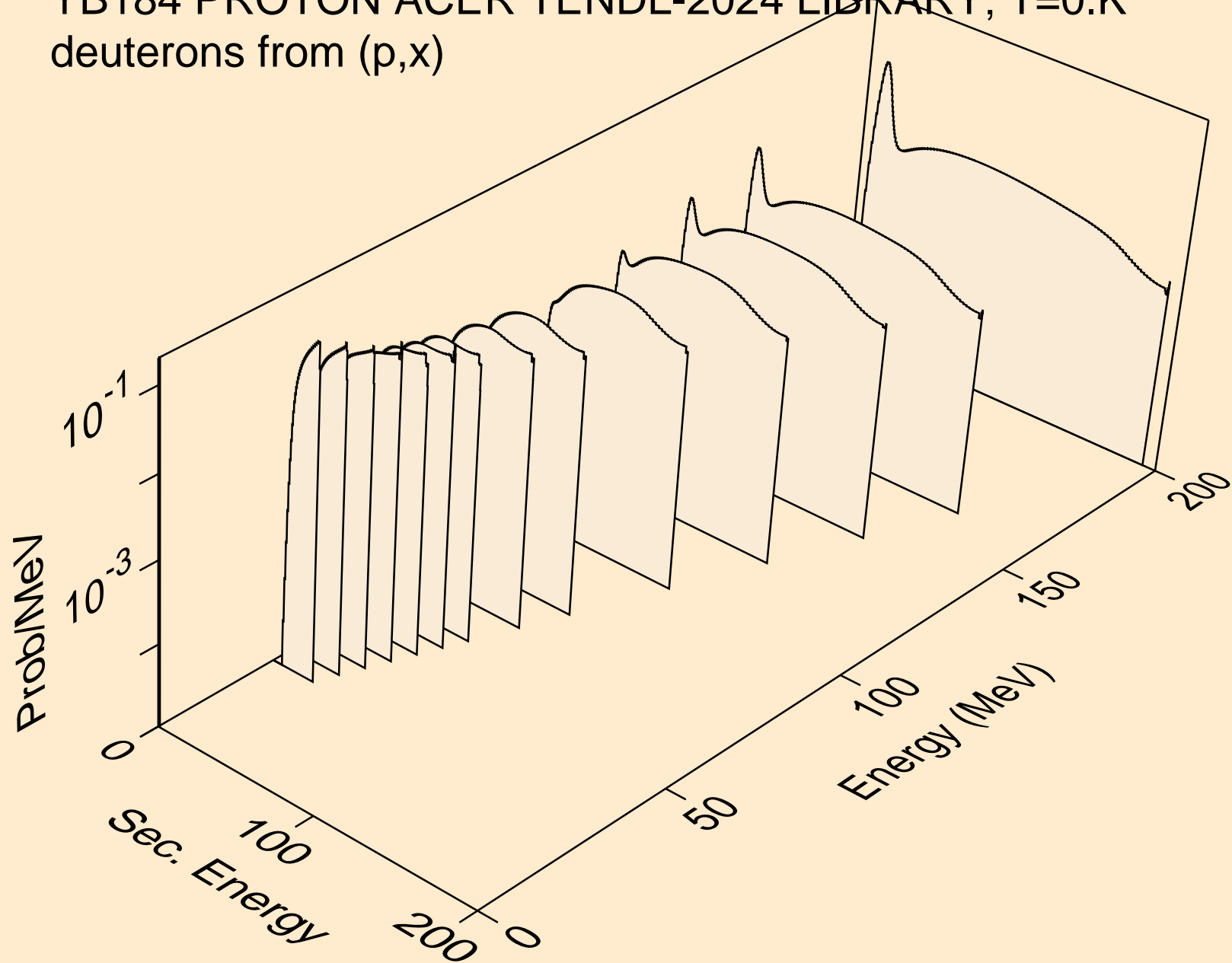

YB184 PROTON ACER TENDL-2024 LIBRARY; T=0.K  
deuterons from (p,2nd)

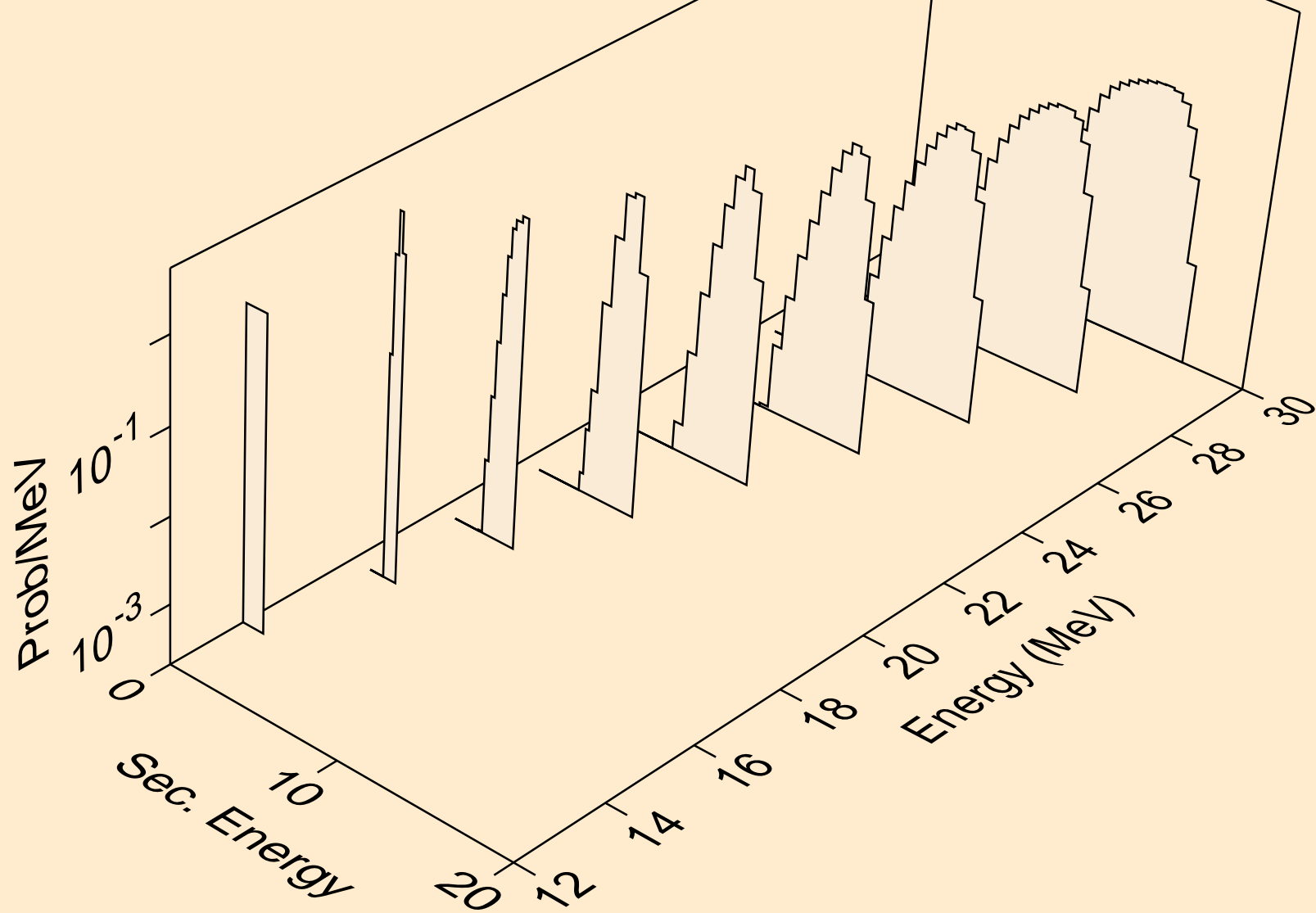

YB184 PROTON ACER TENDL-2024 LIBRARY; T=0.K  
deuterons from (p,n\*)d

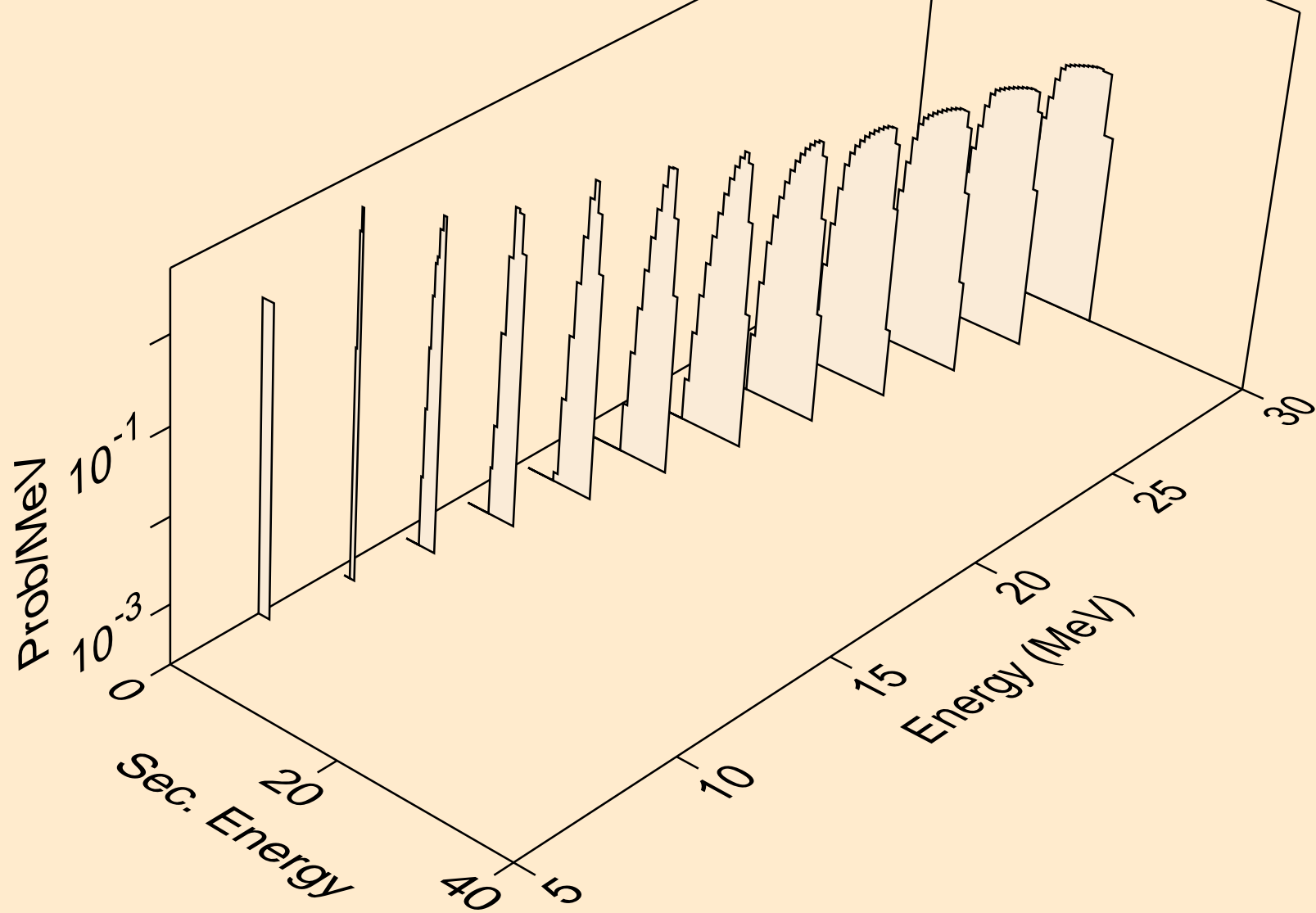

YB184 PROTON ACER TENDL-2024 LIBRARY; T=0.K  
deuterons from (p,d)

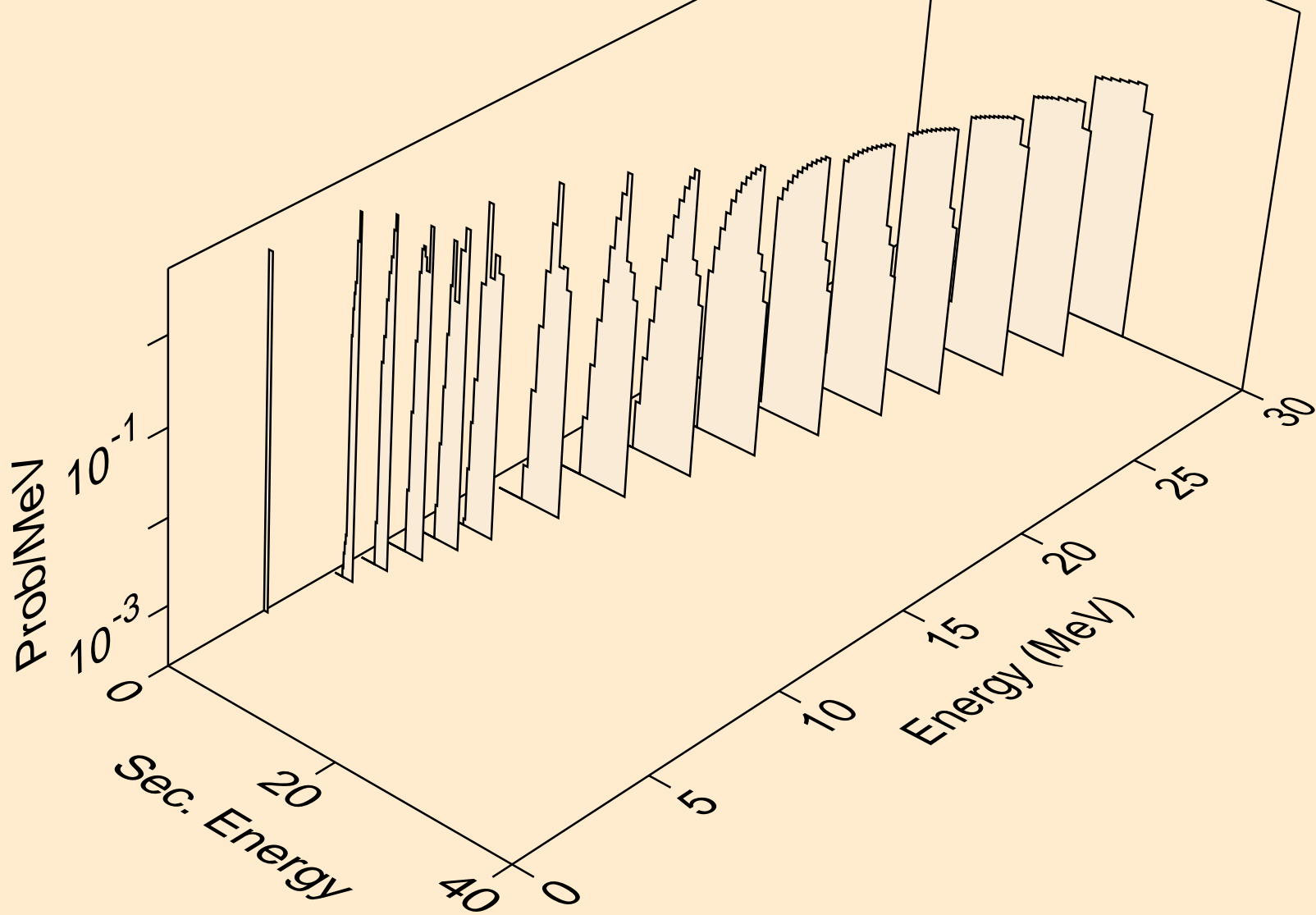

YB184 PROTON ACER TENDL-2024 LIBRARY; T=0.K  
tritons from (p,x)

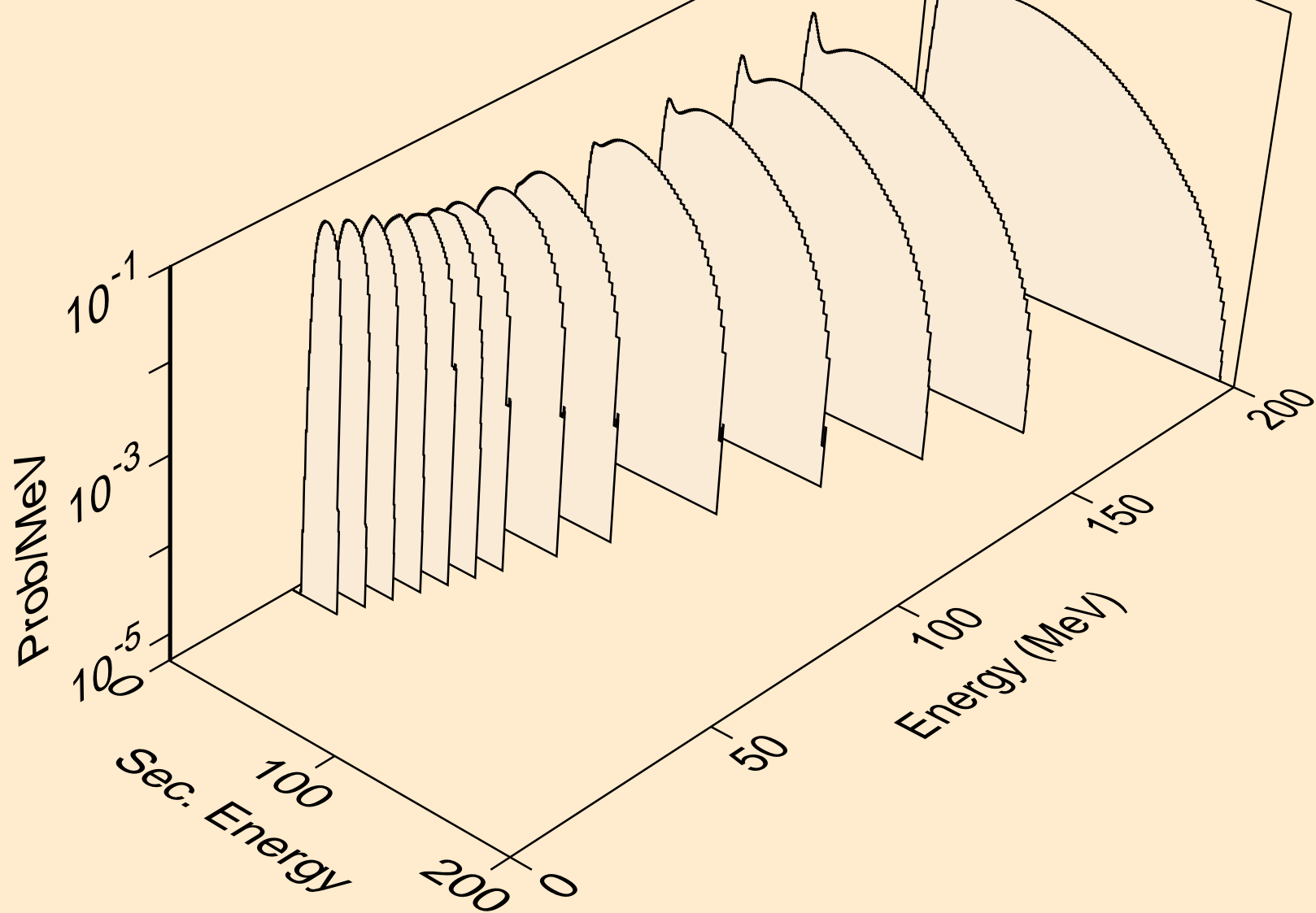

YB184 PROTON ACER TENDL-2024 LIBRARY; T=0.K  
tritons from (p,n\*)t

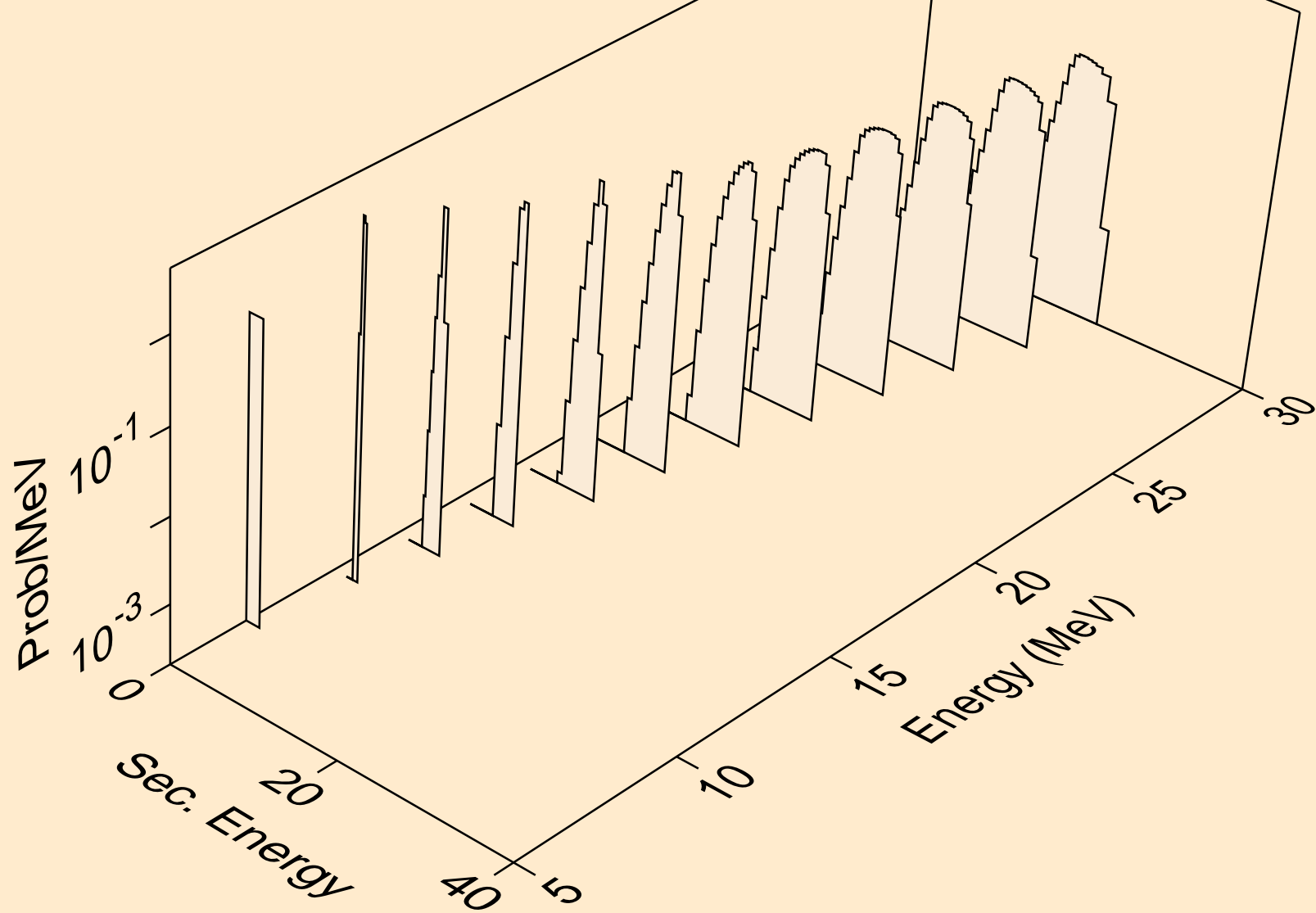

YB184 PROTON ACER TENDL-2024 LIBRARY; T=0.K  
tritons from (p,t)

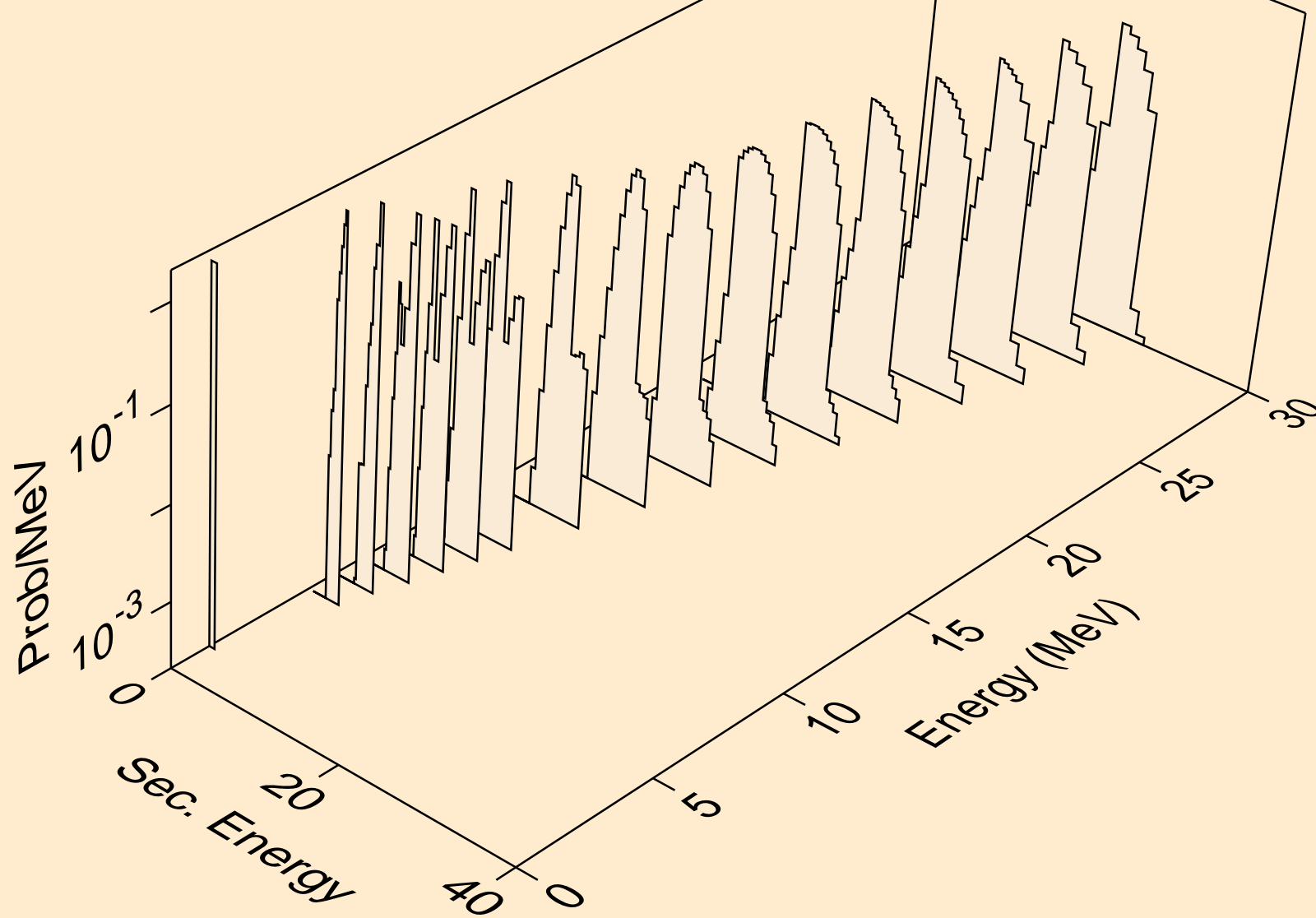

YB184 PROTON ACER TENDL-2024 LIBRARY; T=0.K  
he3s from (p,x)

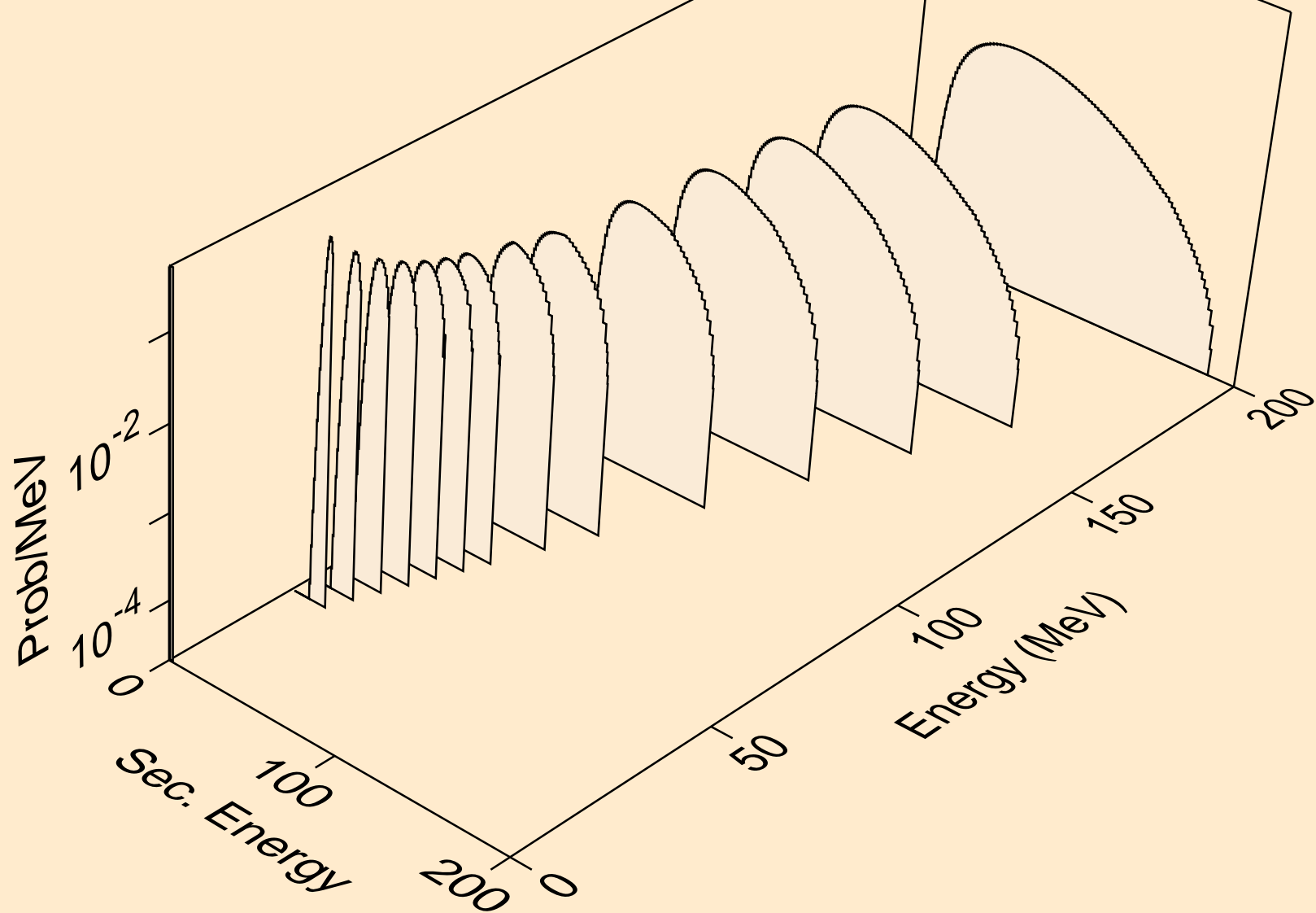

YB184 PROTON ACER TENDL-2024 LIBRARY; T=0.K  
he3s from (p,n\*)he3

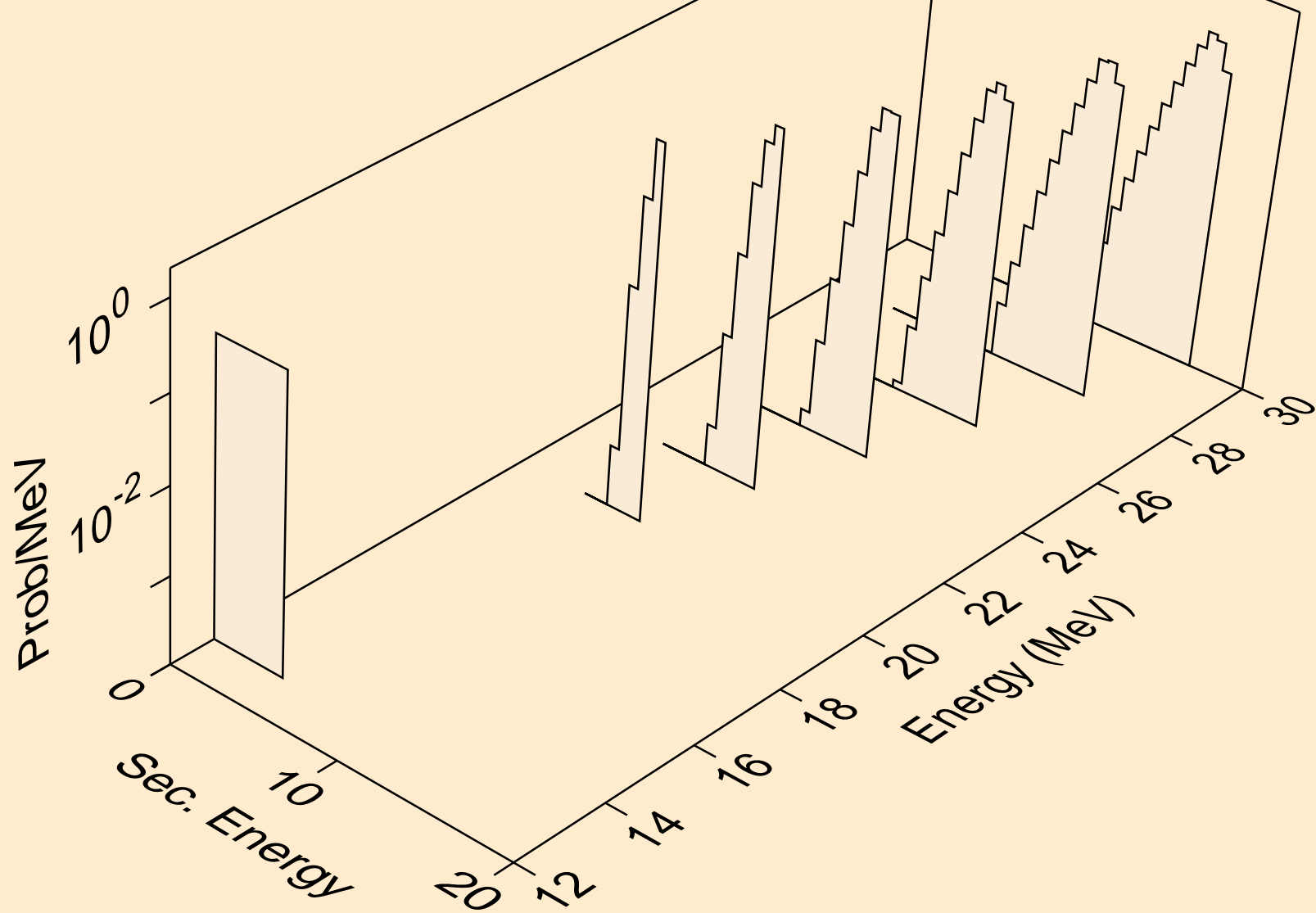

YB184 PROTON ACER TENDL-2024 LIBRARY; T=0.K  
he3s from (p,he3)

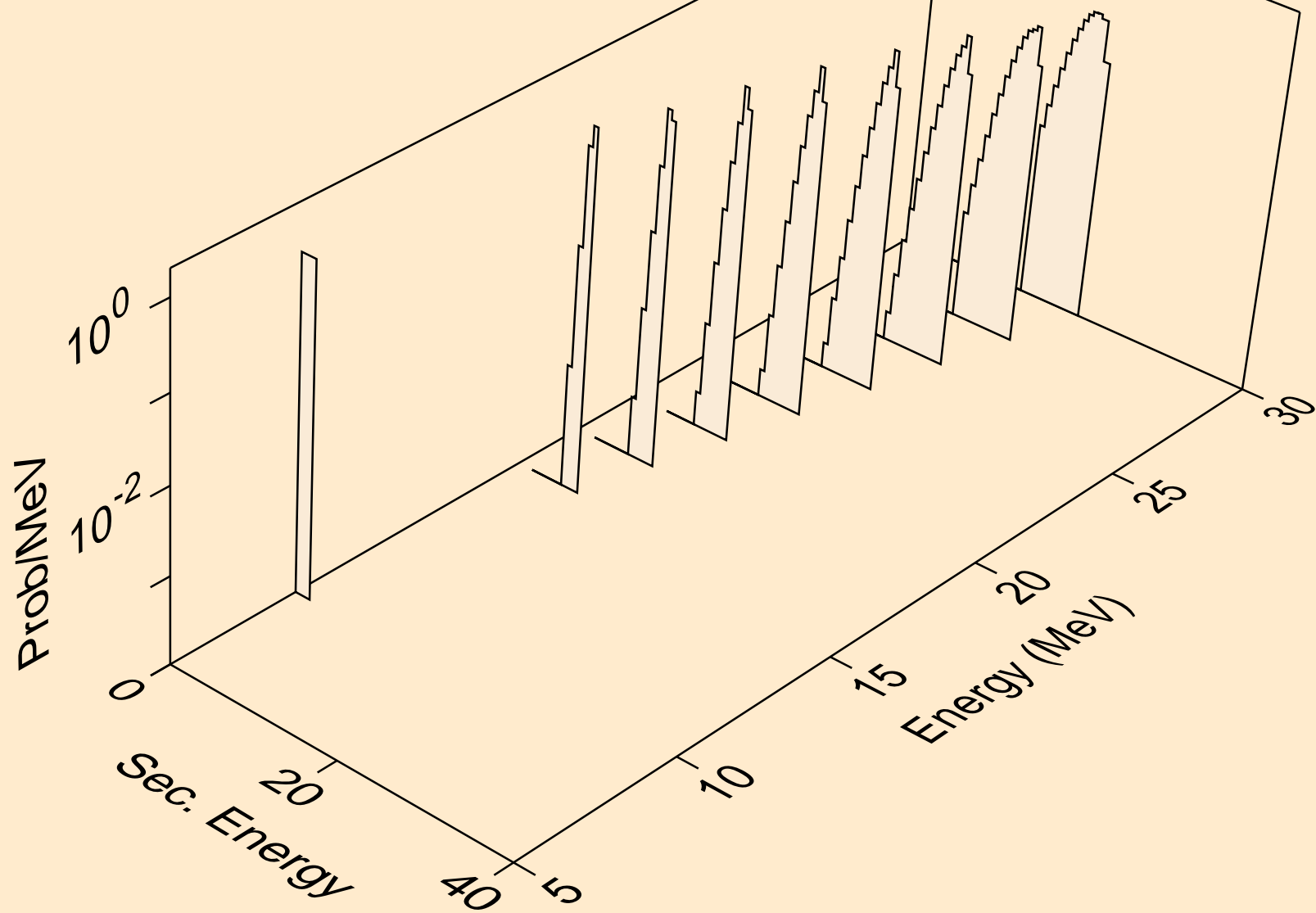

YB184 PROTON ACER TENDL-2024 LIBRARY; T=0.K  
alphas from (p,x)

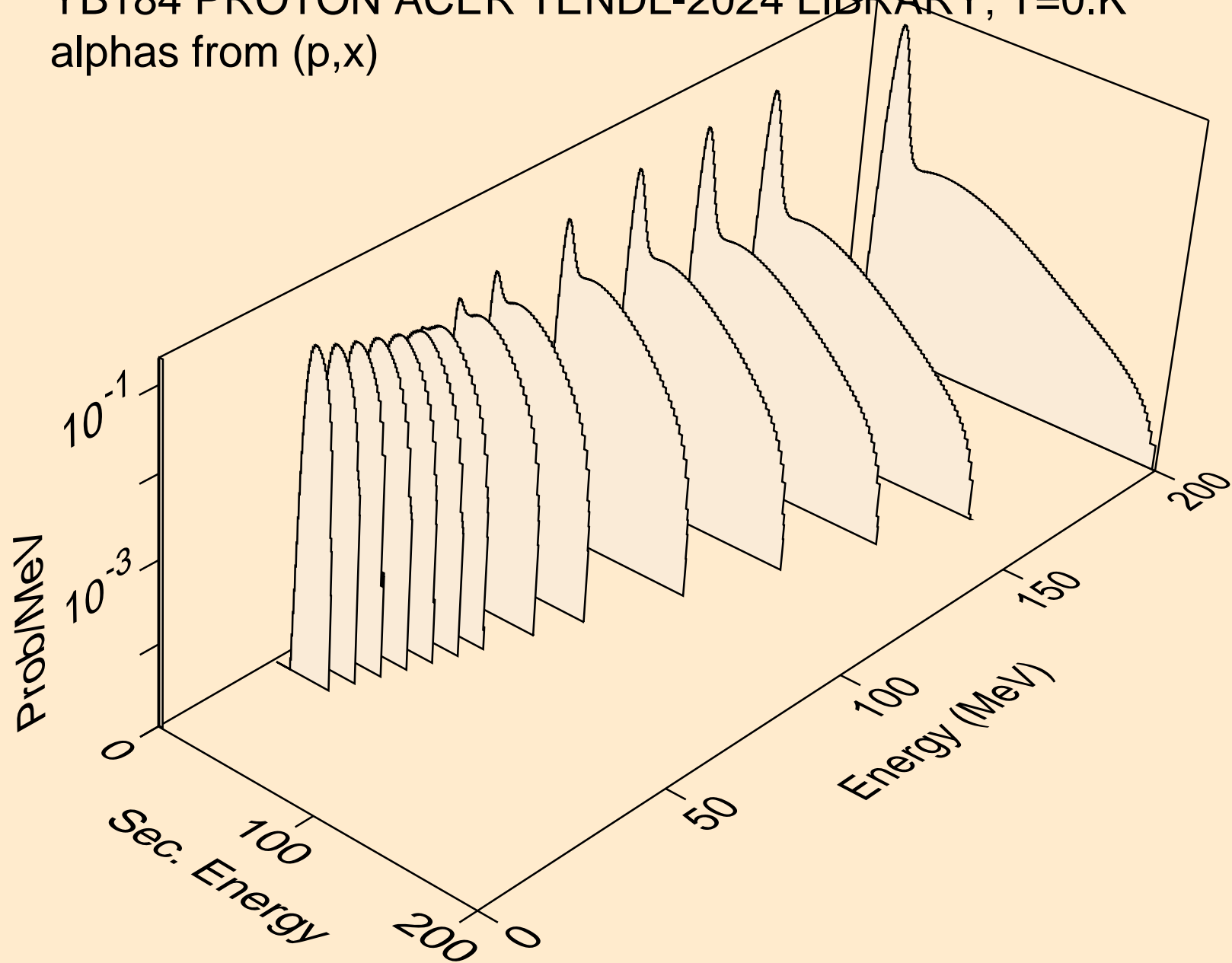

YB184 PROTON ACER TENDL-2024 LIBRARY; T=0.K  
alphas from (p,n\*)a

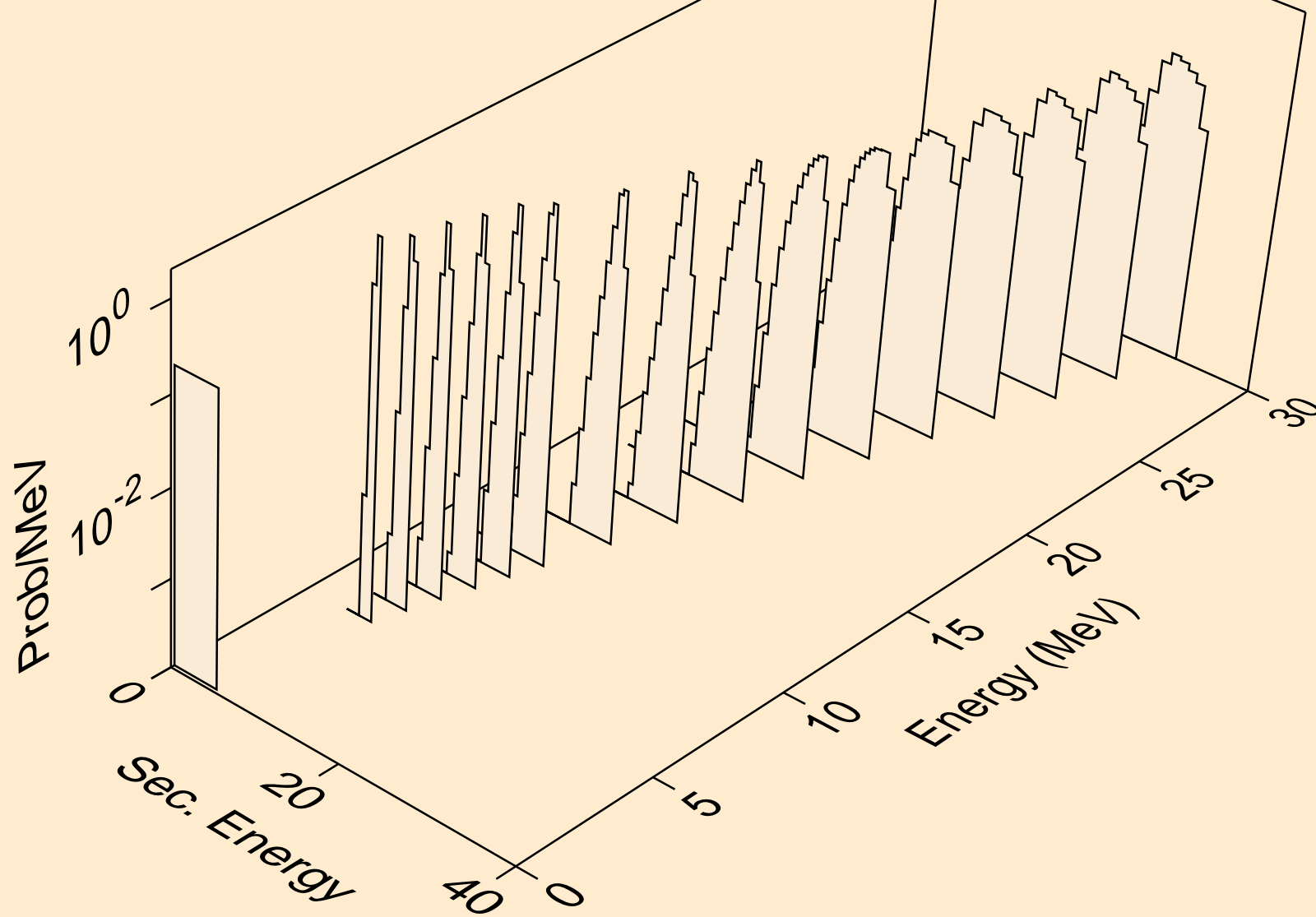

YB184 PROTON ACER TENDL-2024 LIBRARY; T=0.K  
alphas from (p,2n)a

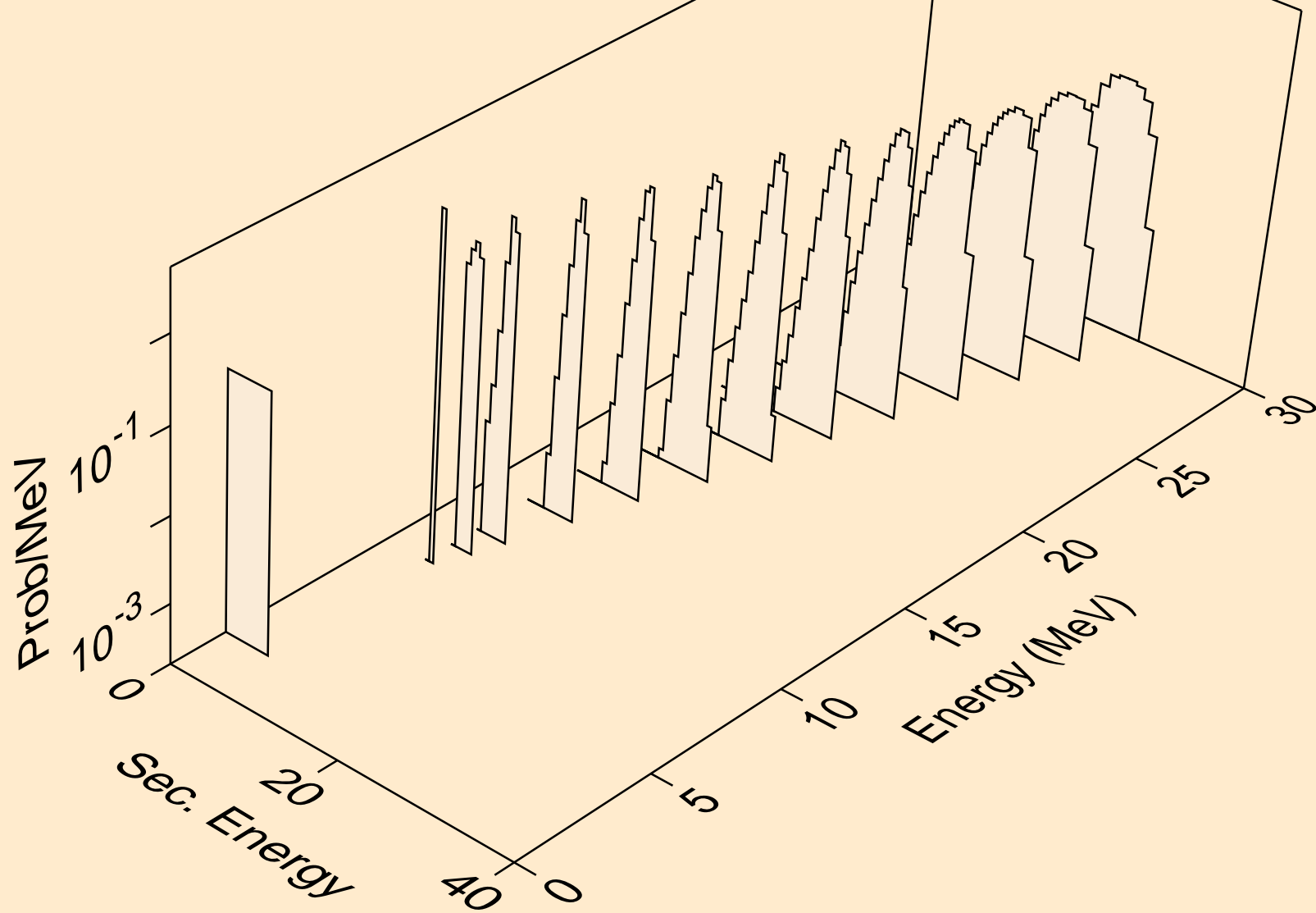

YB184 PROTON ACER TENDL-2024 LIBRARY; T=0.K  
alphas from (p,3n)a

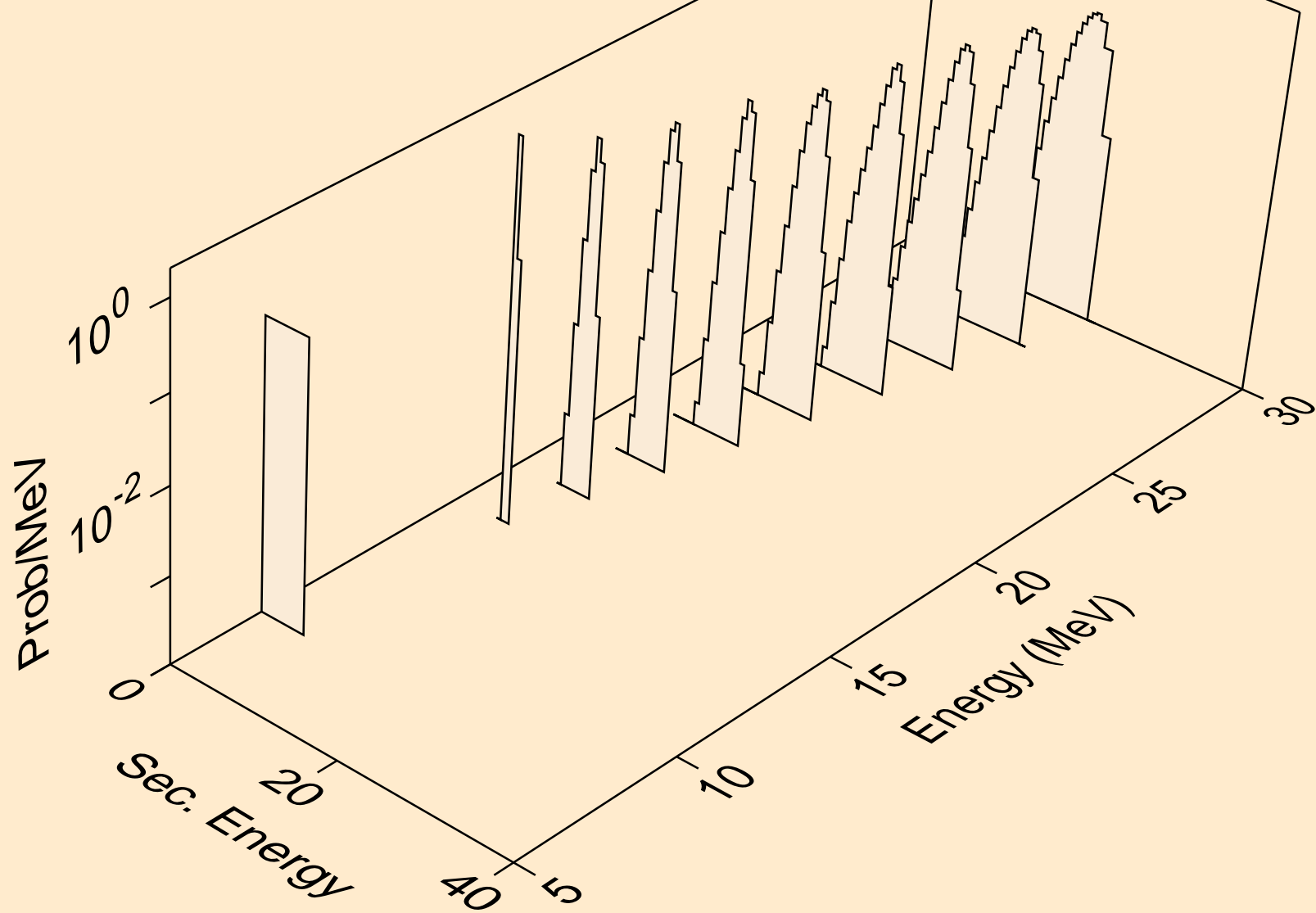

YB184 PROTON ACER TENDL-2024 LIBRARY; T=0.K  
alphas from (p,a)

